

AD-A080 165

NAVAL OCEAN SYSTEMS CENTER SAN DIEGO CA
HF SKYWAVE COMMUNICATIONS TEST PLAN.(U)
NOV 79 G P FRANCIS
NOSC/TD-309

F/G 17/2.1

UNCLASSIFIED

NL

OP/
AD
A080165



END
DATE
FILMED
*3-80
DDC

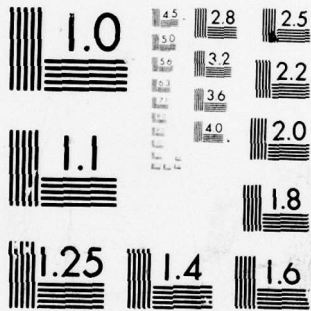

MICROCOPY RESOLUTION TEST CHART
NATIONAL BUREAU OF STANDARDS-1963-A

1 (17) B.S. LEVEL TB

NOSC

NOSC TD 309

NOSC TD 309

Technical Document 309

HF SKYWAVE COMMUNICATIONS TEST PLAN

GP Francis

November 1979

Prepared for
Naval Electronic Systems Command
(Code 310)

DA080165

DDC FILE COPY

DDC
RECEIVED
FEB 5 1980
A

Approved for public release; distribution unlimited.

NAVAL OCEAN SYSTEMS CENTER
SAN DIEGO, CALIFORNIA 92152

80 2 4 040



NAVAL OCEAN SYSTEMS CENTER, SAN DIEGO, CA 92152

A N A C T I V I T Y O F T H E N A V A L M A T E R I A L C O M M A N D

SL GUILLE, CAPT, USN
Commander

HL BLOOD
Technical Director

ADMINISTRATIVE INFORMATION

Test plan was prepared under program element 24163N, Project XO965-CC under the direction of NAVELEX 310.

Released by
HJ Wirth, Head
SATCOM and HF Communications
Systems Division

Under authority of
HD Smith, Head
Communications Systems and
Technology Department

UNCLASSIFIED

SECURITY CLASSIFICATION OF THIS PAGE (When Data Entered)

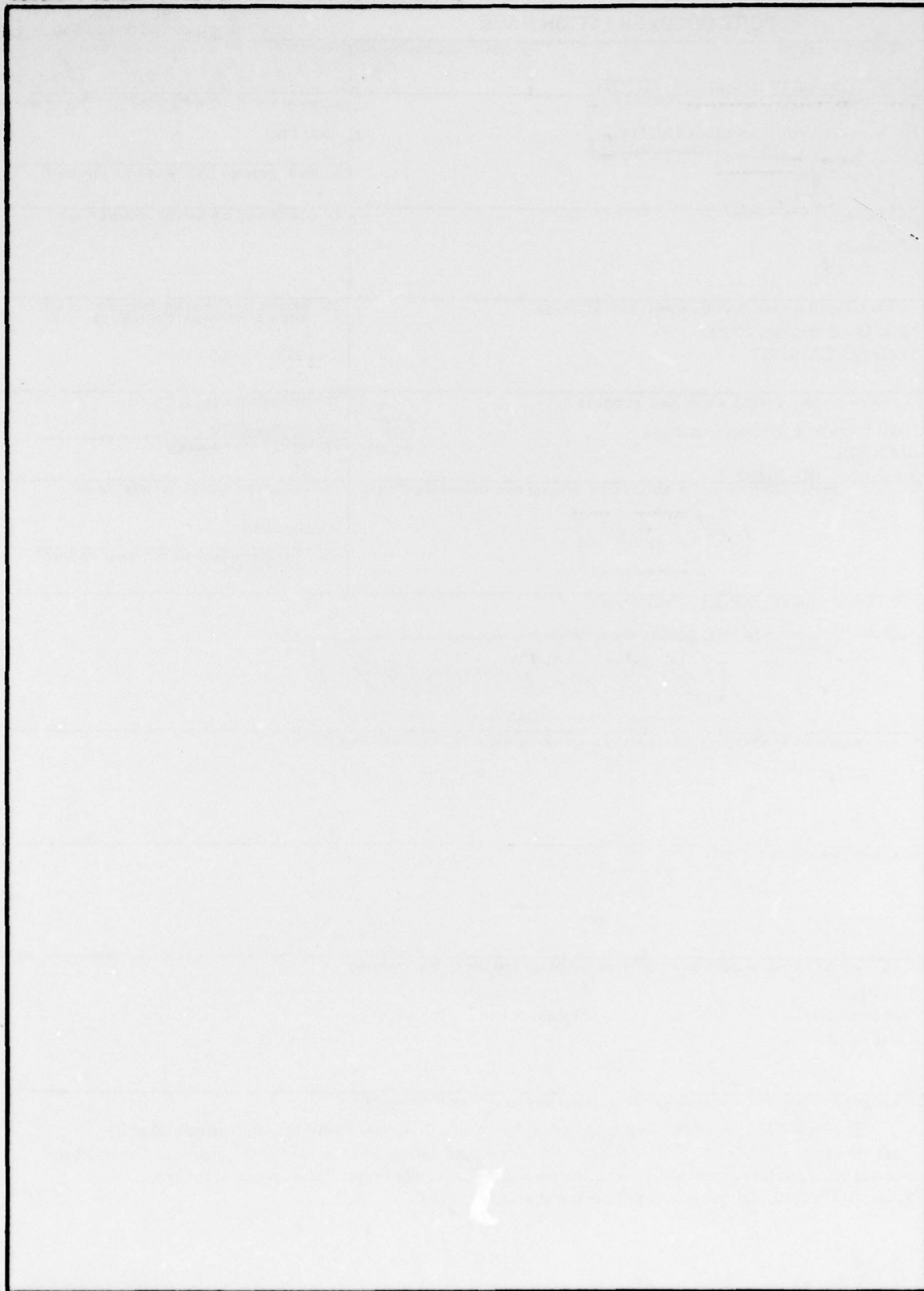

UNCLASSIFIED

SECURITY CLASSIFICATION OF THIS PAGE (When Data Entered)

CONTENTS

1.0	INTRODUCTION . . .	page 3
1.1	Management . . .	3
1.2	Program Identification . . .	3
2.0	SYSTEM DESCRIPTION . . .	3
2.1	System Objectives . . .	4
2.2	Overall Description . . .	5
2.3	System Performance . . .	11
2.4	Operational Modes . . .	12
3.0	TEST REQUIREMENTS . . .	16
3.1	Interface Requirements . . .	16
3.2	Special Requirements . . .	16
3.3	Test Objectives . . .	16
3.3.1	"Back-to-Back" Tests . . .	16
3.3.2	"Short Range" Tests . . .	17
3.3.3	"Long Range" Tests . . .	17
3.4	Test Events . . .	17
4.0	TEST INSTRUMENTATION . . .	17
5.0	SAFETY REQUIREMENTS . . .	18
6.0	SECURITY REQUIREMENTS . . .	18
7.0	REFERENCES . . .	19
	APPENDIX A: MAGNETIC TAPE FORMAT AND LABELING . . .	21
	APPENDIX B: TEST DESIGNATORS AND FREQUENCIES . . .	26

Accession For	
NTIS CARD	<input checked="" type="checkbox"/>
DDC TAB	<input type="checkbox"/>
Unannounced	<input type="checkbox"/>
Justification	<input type="checkbox"/>
By _____	
Distribution/	
Availability Codes	
Dist	Avail and/or special
A	

ILLUSTRATIONS

1. Basic HF Skywave evaluation system . . . page 4
2. HF Skywave test geometry . . . 6
3. Field test schedule . . . 6
4. Transmit terminal . . . 7
5. PSK modulator . . . 8
6. Receive terminal . . . 9
7. Possible signal transmission sequence . . . 13
8. Message recording periods . . . 15
9. HF sounder system . . . 15
- A1. Tape formats . . . 22

TABLES

1. Signal transmission characteristics . . . page 14
2. Test events . . . 18
- A1. Parameter Block Description . . . 23

1.0 INTRODUCTION

The Skywave Communication project is part of an overall program of the Navy to develop improved and more reliable hf intratask force and longer range communications.

The Skywave Communication task⁽¹⁾ was initiated in September 1976 (FY76) under the direction of NAVELEX 310 and with the objective of developing communication signal processing techniques for hf channels consisting of surface wave and/or skywave modes of propagation. The approach was to: (1) develop a wideband channel model and software simulation system; (2) develop signal processing techniques and evaluate using simulation techniques; and (3) perform hf experiment and record signals for off-line verification of the channel model and the signal processing algorithms. Both narrowband and wideband channels are being addressed. The subject of this test plan is the hf experiment and signal recording.

A more detailed description of the task is found in reference 1.

1.1 MANAGEMENT

The various individuals in the overall program are listed below:

<u>Function</u>	<u>Name</u>	<u>Org/Code</u>	<u>Phone</u> <u>Comm/AV</u>
Program Manager	I. L. Smietan	ELEX/310	202-692-6093 (AV 222-6093)
Project Manager	I. C. Olson	NOSC/8105	714-225-7093 (AV 933-7093)
Task Manager	L. E. Hoff	NOSC/8142	714-225-6732 (AV 933-6732)
System Engineer	A. L. Heaberlin	NOSC/8142	714-225-6856 (AV 933-6866)
Test Engineer	G. P. Francis	NOSC/8142	714-225-7073 (AV 933-7073)
Software Engineer	J. H. Thornton	NOSC/8142	714-225-7451 (AV 933-7451)
Design Engineer	A. R. King	NOSC/8142	714-225-6550 (AV 933-6550)
Point Mugu Liaison	C. G. Elliott	PACMISTESTCEN/ 0141-2	805-982-8847 (AV 351-8847)
Hawaii Liaison	Jesse Burks	NOSC/32	808-254-4444 —

1.2 PROGRAM IDENTIFICATION

The Skywave Communication project has the following program identification.

Program Element #24163N
Project X0965-CC

2.0 SYSTEM DESCRIPTION

Most hf systems currently in use are 1950 designs. They use long baud durations to combat intersymbol interference from multipath, and use several parallel modulated tones to achieve high data rates. However, other distortions that occur in the hf channel, such as selective fading, dispersion, doppler shifts, and interfering signals, continue to cause high

1. Naval Ocean Systems Center Technical Report 210, "Skywave Communication Techniques: A Status Report for FY77," by L. E. Hoff, December 1977.

error rates. In an attempt to overcome these distortions, redundancy in the form of in-band diversity and error detection and correction codes are used extensively. In spite of all of this, error rates of 10^{-3} still occur about 50 percent of the time.^(2,3,4)

It is obvious that if the challenge of improved hf intra task force communications is to be met, new designs must include not only a means of measuring and tracking the time-variant channel response but also a method of adapting the system to these changes. The best area to provide this adaptivity to the communication process is at the receiver.

The system described in this test plan has the primary purpose of gathering data on hf skywave propagated signals which will be used for the development of improved hf intra-task force communications. The basic system is shown in figure 1.

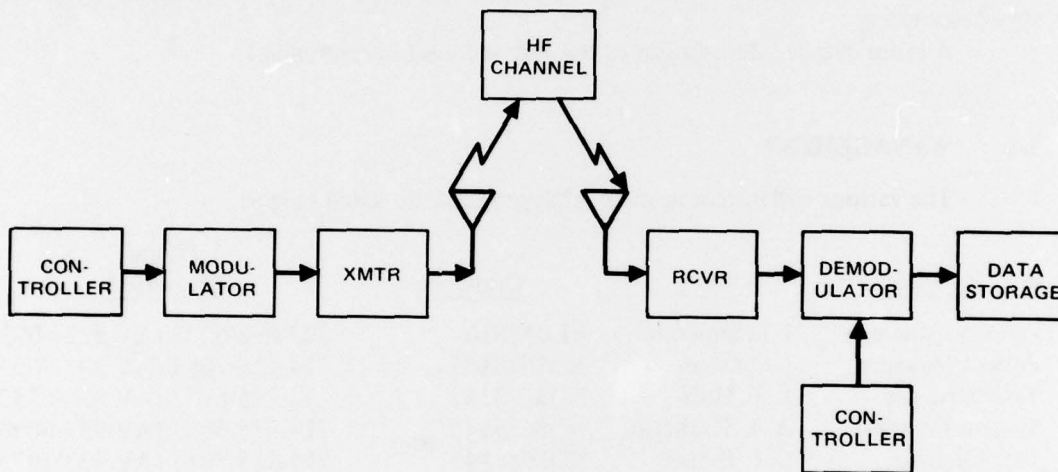

Figure 1. Basic HF Skywave evaluation system.

2.1 SYSTEM OBJECTIVES

The object of this test is to develop a data base which will be used to evaluate and analyze several adaptive signal processing algorithms. The interface will consist of both wideband and narrowband data. The wideband test data will be QPSK at a symbol rate of 2400 Hz. The narrowband data will be QPSK, BPSK, and QDPSK (Kineplex-Link-11) also at a symbol rate of 2400 Hz.

Since the performance of each algorithm is channel-dependent, the channel parameters at the times of each test will also be measured and recorded. This data will be used to verify the channel model previously developed to allow hf channel simulation and thus the algorithm performance checks. If the developed hf channel model proves valid, or can be corrected to more closely follow the measured channel parameters, it will be used in subsequent adaptive signal processing algorithm development and hf channel simulation.

2. Mitre Corporation TM04101, ESD-TDR-64-631, "Comparative Performance Evaluation of Digital Data Modems for HF Radio," by R. E. Grein, W. R. Menges, F. N. Nelson, Jr.
3. Naval Electronics Laboratory Center Report 1634, "Error Rate Observed on HF Multichannel Fleet Broadcast System," by G. B. Johnson and G. P. Francis, 28 July 1969.
4. Naval Electronics Laboratory Center Report 1686, "Error Control in HF Fleet Broadcast System," by J. L. Heritage, 10 February 1970.

The channel model validation will consist of a deterministic and a stochastic comparison. The deterministic comparison will be a test of how well the model can reproduce a specific hf channel. Several hf channels will be measured and simulated. The mean square error between the channel and model impulse response will be computed by averaging the errors from each channel. It is anticipated that this error will be a function of channel bandwidth. The stochastic comparison will be a test of how well the model can reproduce the randomness of the hf channel. The comparison will be based upon the channel covariance function which is a second order statistic. We will compute the mean square error between the channel and model covariance function for several channel bandwidths and center frequencies.

Validation of the signal processing algorithms will consist of comparing their error rate performance using recorded data and simulated data from the channel model. This comparison will provide:

- (1) error rate estimate of the algorithms for real hf channels; and
- (2) a measure of comparability of the error rates predicted from simulation versus those realized from an actual hf channel.

Two algorithms will be evaluated for the narrowband data, the maximum likelihood sequence estimator (MLSE) and the decision feedback equalizer (DFE). For wideband data, the RAKE, linear equalizer, and DFE will be compared. Reference 1 gives background information on these algorithms and references 5 and 6 address the hf channel model.

2.2 OVERALL DESCRIPTION

Figure 2 illustrates the geometry of the hf skywave field tests. Two propagation paths will be investigated – “short range” and “long range.” The receiver site will be fixed and located at Point Loma in San Diego. The reason for establishing the fixed site at NOSC-Point Loma is that the receive terminal is much more complicated than the transmit terminal. Thus less equipment has to be transported and maintenance support is more easily obtainable. The test will consist of two phases of identical proportions with only the transmitter location changing. The first phase will be the “short range” test between Point Mugu and Point Loma. The second phase will be the “long range” test between a location in Hawaii on the island of Oahu and Point Loma. All objectives and test events for these two phases will be identical, therefore no attempt will be made to differentiate between the two in the remainder of this plan. Suffice it to say that the test conducted between Point Mugu and Point Loma will be repeated in its entirety between Hawaii and Point Loma.

The transmitter for the “short range” test will be set up in Building 14 at the Pacific Missile Test Center at Point Mugu, California. For the “long range” test, it is anticipated to set up the transmitter at the NOSC facility at Kaneohe Bay on the island of Oahu, HI. The receiver for both tests will be located in the “transmitter room” of building 382 (model range) at NOSC.

Figure 3 gives the schedule for the field tests.

Figure 4 shows a block diagram of the transmitter site. The transmit terminal must generate the required signals – PSK, Kineplex, and a CW tone. The PSK signals will be both

5. Naval Ocean Systems Center, Technical Report 208, “HF Channel Simulator for Wideband Signals,” by R. Lugannani, H. G. Booker, and L. E. Hoff, March 1978.
6. Naval Ocean Systems Center, Addendum 1 to Technical Report 208, “HF Channel Simulator for Wideband Signals,” by R. Lugannani, H. G. Booker, and L. E. Hoff, November 1978.

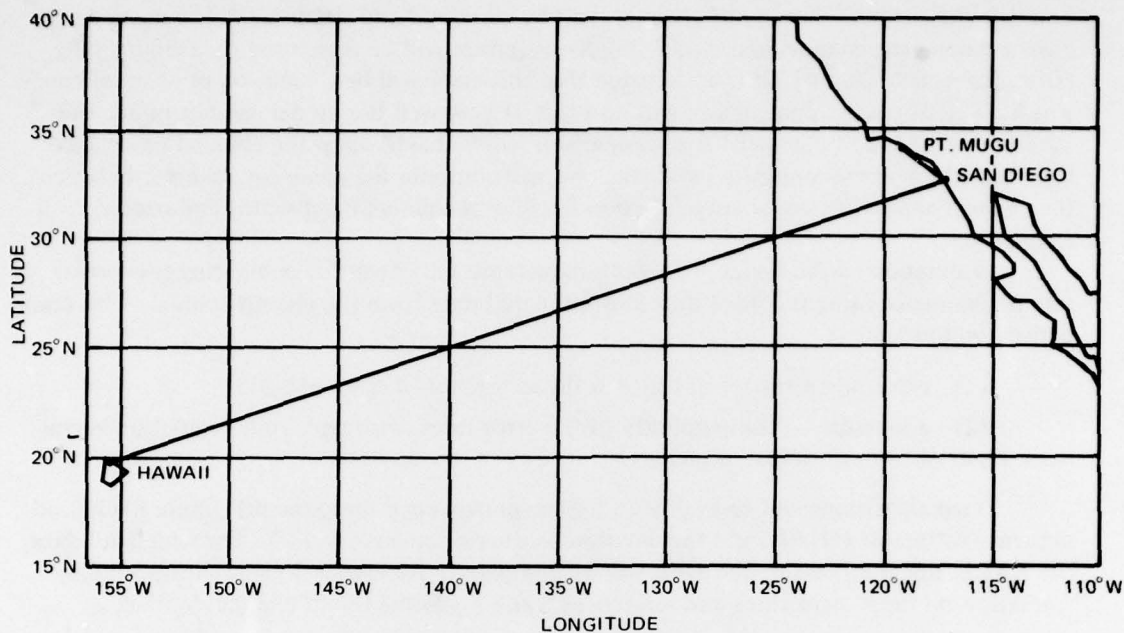

Figure 2. HF Skywave test geometry.

	1979			1980				
	OCT	NOV	DEC	JAN	FEB	MAR	APR	MAY
BACK-TO-BACK					—△		—△	
PT. MUGU						△		
HAWAII								—△

Figure 3. Field test schedule.

wideband and narrowband and also biphase (BPSK) and quadphase (QPSK). These signals will be used to analyze the adaptive algorithm performance. The Kineplex signal will be used as reference to allow a comparison between the adaptive algorithm performance and existing modulation schemes. The CW signal will be used for system calibration and to measure power loss. The keyer will generate both the CW tone and the PSK signals. The Kineplex signal will be generated by a separate Kineplex modulator. In addition to these signals, several "sounder" type signals (described later) will be generated by the keyer and used to measure the hf channel parameters.

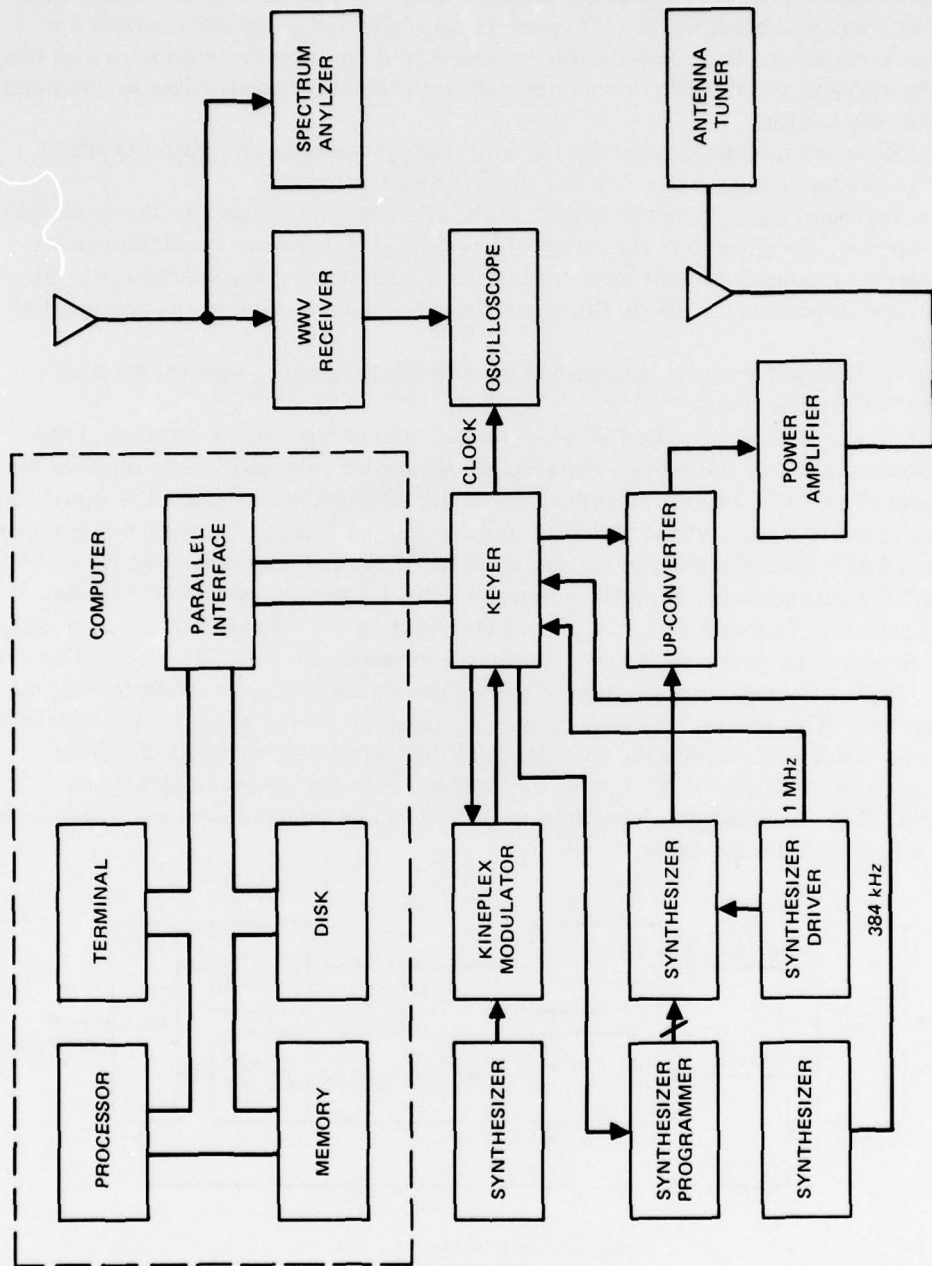

Figure 4. Transmit terminal.

Control for the transmitter terminal resides in the PDP-11/20 computer. The computer starts the modulator at the appropriate time and in sync with WWV, selects which modulation format will be used (PSK, CW tone, Kineplex, or sounder signals), which bandwidth will be used, and controls the rf frequency. Basically, the computer controls the entire transmit terminal. The computer system consists of an operator terminal, a disk (for program storage) and an interface to communicate with the keyer, synthesizer programmer, and Kineplex modulator.

The Kineplex modulator provides the Link-11 type signal (narrowband QDPSK) which will be used as a comparison base for the receive performance.

The baseband signal from the keyer and the Kineplex modulator (via the keyer) is fed to the upconverter where it is converted to low-level rf at a frequency established by the computer (in conjunction with the synthesizer programmer and the synthesizer). This rf signal is then amplified to 1 kW by the power amplifier and supplied to the antenna for transmission.

A WWV receiver and oscilloscope will be used to coordinate, synchronize, and monitor the transmitter timing.

The keyer must provide the PSK modulation. Figure 5 is a block diagram of the PSK modulator section of the keyer. The PSK modulator accepts binary data supplied by the computer at a rate of 2400 baud and produces the PSK baseband signal. The signal can be both wideband and narrowband and both biphase and quadphase. Narrowband data goes directly to a 3 kHz filter and then to the multiplexer. Wideband data is generated by "spreading" the data sequence from the computer with the bits (chips) supplied by the sequence generator. The data period is 1/2400 Hz and there are 40 chips during each period. Two bits are generated (one real and one imaginary) for each chip period (1/96 000 Hz). The encoder multiplies the two complex numbers from the sequence generator and the message register together. This complex number then determines the proper phase for the wideband QPSK signals. From the encoder the spread (wideband) signal goes to a 100 kHz filter and then on to the multiplexer where selection is made between wideband QPSK and narrowband QPSK. In addition, the imaginary output can be disabled resulting in a real output only, which provides the BPSK signals.

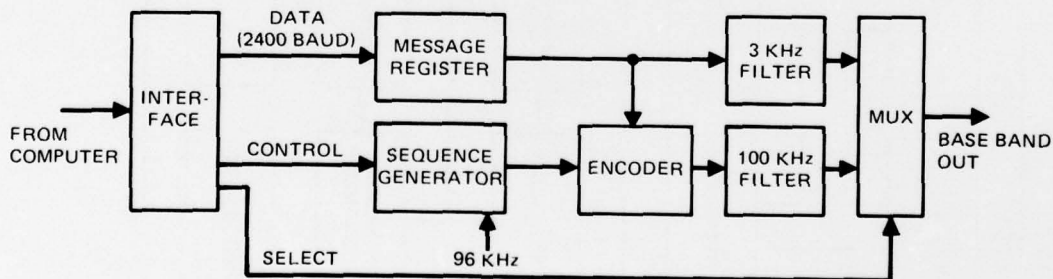

Figure 5. PSK modulator.

Figure 6 shows a block diagram of the receiver site. The receive terminal is basically a data acquisition system – acquiring the transmitted signals, converting them into digital format, storing them on a magnetic disk, and subsequently transferring the data from the disk to magnetic tape for later processing. At preselected times, various signals will be received, digitized, packed (four 12-bit data strings into three 16-bit words) into a buffer and

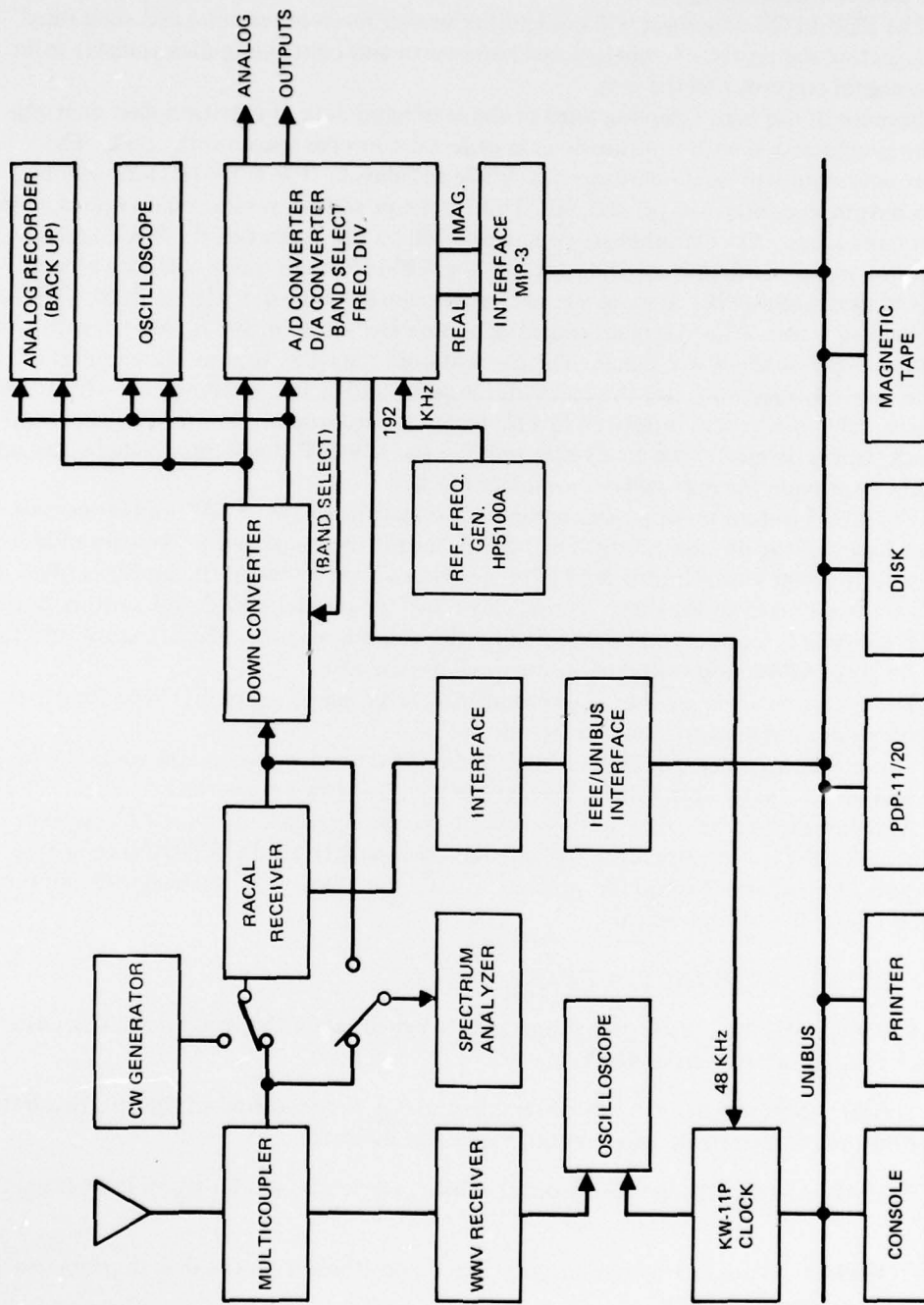

Figure 6. Receive terminal.

then stored on a disk. After each transmission, the data will be unpacked and transferred from the disk to magnetic tape.

The PDP-11/20 computer will control the overall receiver terminal and such functions as selecting the receiver frequency and bandwidth and controlling data transfer from analog-to-digital converter to the disk.

Because of the high sampling rates of the wideband data, it is critical that data collection be synchronized with transmissions in order to conserve space on the disk. The computer operation will be synchronized to WWV as follows. The KW-11P clock will be set up to output one interrupt per second. This interrupt will be monitored on one channel of a dual trace scope. On the other scope channel will be the output of the WWV receiver. The operator will monitor the scope and adjust the KW-11P clock under software control until it is in synch with WWV (i.e., clock interrupts coincide with the 1 Hz ticks of WWV) to within less than 1 ms. Thus the main source of timing error will be due to error in estimating propagation delay of the WWV signal. The clock should then stay in sync for a period of approximately 24 hours (or until the computer is rebooted) as it is driven by the HP5100A synthesizer. The synthesizer outputs 192 kHz which is used directly as the wideband sampling clock; this is divided down to 48 kHz to drive the KW-11P clock and divided down again to 4.8 kHz to provide the narrowband sampling clock.

The MIP-3 (micro input processor) interface consists of two MIP-3 units (one unit for the real part of the digitized output and the other for the imaginary part) whose function is to pack four 12-bit words into three 16-bit words in a buffer. When the buffer is filled its contents are transferred to the disk. During this transfer time the MPS-3s fill another buffer.

The RACAL receiver can be adjusted by the computer via the IEEE/Unibus interface and can be checked out and calibrated using the CW generator.

The spectrum analyzer is used to monitor received signal strength, check for other user interference, and monitor the receiver output.

The analog recorder will be used for a backup data collection system while the oscilloscope will check the baseband output signal levels of the down converter.

As mentioned earlier, the "heart" of both the receiver system and the transmitter system is the PDP-11/20 computer. Software has been written (in FORTRAN) to enable the computer to perform its required functions. Below is a list of the various software programs and a brief description of each.

RECEIVE TERMINAL SOFTWARE

CLOCK – Enables the terminal operator to synchronize the computer clock with Universal Time as received from WWV.

ATOD – Sets up the schedule of sampling and A/D conversion of the two quadrature detector outputs and controls information transfer to the disk.

TOTAPE – Unpacks the data from the disk, reorganizes it, and stores it on magnetic tape.

TODISK* – Packs data from magnetic tape and stores it on the disk in proper format for use by the program DTOA.

DTOA* – Takes formatted digitized data from the disk and produces two analog outputs (one corresponding to each quadrature detector output that was originally digitized).

* Field tests can be performed without these programs.

TRANSMIT TERMINAL SOFTWARE

XMIT – This is the main routine and is responsible for the overall control of the transmit terminal. Information is read from a file which sets up the correct frequency, modulation type, message length, and random number generator seeds. The operator enters the exact time for the transmission to be made. The WWV clock is read (via INTHND described below), and for each message in the transmission sequence the generate message (GENMSG) routine is called.

GENMSG – The generate message routine is responsible for setting up the message buffer and outputting this data into the keyer. Bits are loaded into a buffer and at the time for transmission sets up the modulation handler (MODHND) routine which outputs the message bits from the buffer to the keyer. As buffer space becomes available, new bits are placed into the message buffer until the message is completed.

INTHND – This is the WWV clock interrupt handler routine and is responsible for updating the WWV clock and calling the modulation handler (MODHND) routine (once every 2400 Hz).

MODHND – This is the modulation handler routine and uses the message buffer setup in the GENMSG routine. New message bits are output to the keyer each time the WWV clock is updated (each 2400 Hz). If the message buffer is empty, an error condition is generated.

2.3 SYSTEM PERFORMANCE

Before any data is collected the system will be checked out to ensure its proper operation. At the receive site this will be done by injecting a known signal into the A/D converter and writing it onto the disk. Then it will be transferred onto tape and analyzed by comparing it against the known input. The receiver and down converter will be checked by monitoring a known signal (say WWV) or the signal from the CW generator. The backup recorder will be checked by playing back its contents and ensuring it matches the known input.

The transmitter terminal will be checked out similarly, by monitoring signals and waveforms on the oscilloscope and the spectrum analyzer and also by using the receiver site as a monitor for the "on-the-air" checkout phase.

Before any data transmissions are made, the spectrum analyzers will be used to monitor the assigned test frequencies. The operator will pick the one with the least interference on both ends of the link.

Constant monitoring will take place during all message transmissions. Each data tape will be given a "quick look" (data extracted from several random locations) shortly after it is made to ensure its contents and quality.

Data for the various modulation schemes will be taken during the day and the night over a period of several days to ensure that an adequate data base is collected.

2.4 OPERATIONAL MODES

As has been mentioned earlier, the overall system is capable of operating in several "signal type" modes. There are two main modes each having several sub modes. They are broken down as follows:

"Sounder" Modes

- CW
- COMB
- IMPULSE

"Data" Modes

- Wideband QPSK
- Narrowband QPSK
- Narrowband BPSK
- Kineplex

The "sounder" mode signals will give information on the hf channel parameters and they will be used to verify the channel model. The "data" modes will have the information needed to measure the performance of the adaptive algorithms. A brief description of each mode now follows.

The CW signal will be centered on the transmitter center frequency. Its purpose is to calibrate the wideband and the narrowband systems and to measure the received power level.

The COMB signal will consist of a multitone CW signal (40 tones maximum), each tone separated from the adjacent channel by 1.25 kHz. Any combination of channels can be selected by the computer.

The IMPULSE signal will consist of a wideband QPSK sequence. Because of its wide bandwidth, information on the channel impulse response will be obtained.

The wideband QPSK signal is a spread spectrum signal with a baud rate of 2400; each baud is differentially encoded, has one of four possible phases (45° , 135° , 225° , 315°), and spread out by 40 chips. The resultant chip rate is 96 000.

The narrowband QPSK signal is differentially encoded and has a baud rate of 2400.

The narrowband BPSK signal is differentially encoded, has a baud rate of 2400, and each baud has one of two possible phases (0° or 180°).

The Kineplex signal will be narrowband and consist of 16 tones (simulating the Link-11 tone package); the baud rate is 2400 and each baud is QDPSK modulated. This signal will be used to establish a baseline for comparison between the other narrowband modulation methods.

Figure 7 shows a possible sequence for signal transmission and also the length of each "message." Each "message" type is further amplified in Table 1. In addition, each "message" will have a 0.5 second dead period before and after the message during which time no signals are transmitted. See figure 8. Thus messages are separated from each other by 1.0 second. This allows time for the transmit and receive terminals to make the necessary adjustments (i.e., sampling rate and filters) and also allows the receiver terminal to monitor the noise. The noise will be recorded for 0.4 seconds before and after each message.

As has been mentioned earlier, all information will be placed on magnetic tape. Appendix A contains information on the tape format and labeling.

Also a stochastic message will be sent. This message will consist of the impulse sounding message and will be transmitted once every second. The impulse sounding message

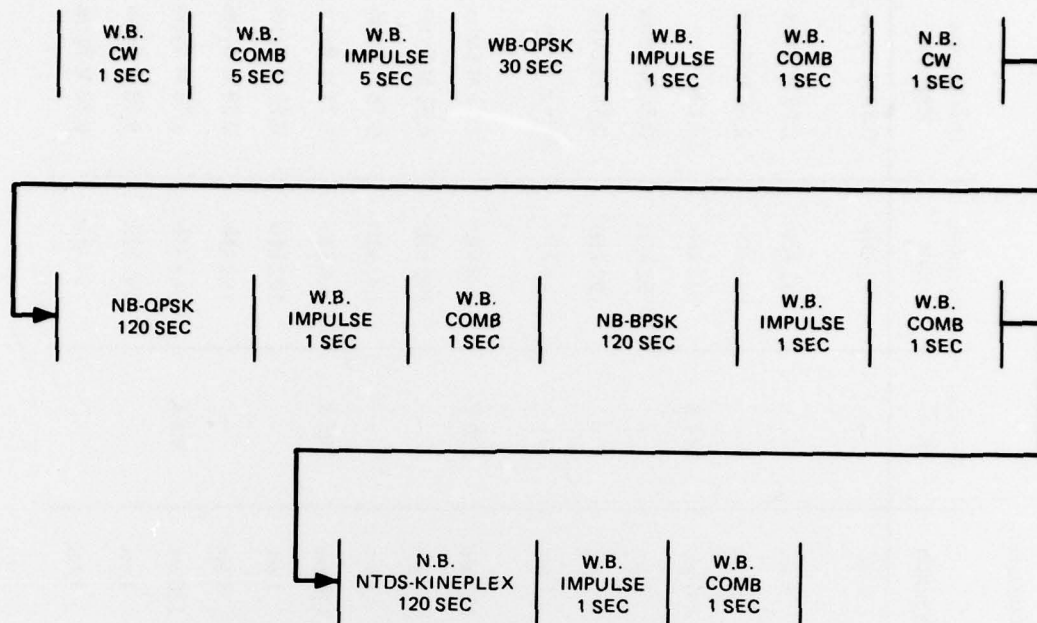

Figure 7. Possible signal transmission sequence.

is the wideband QPSK modulation signal and will have a duration of approximately 100 milliseconds. This information will be used to construct the doppler shift and the doppler spread (channel fading) and will be used to further evaluate the hf channel model. This data will be recorded on magnetic tape as the other field test sounding measurements are recorded.

Additionally, a simple hf sounder will be provided which will allow for the real time oscilloscope display of the ionospheric modal structure of the propagation path. The sounder system has the following characteristics:

- a. Bandwidth = 3 kHz
- b. Modal magnitude amplitude resolution = 16 bits
- c. Modal arrival time resolution = 300 μ sec.
- d. Matched filter output data refresh rate \approx 3.6/sec.
- e. Output data format = 64 correlation points

This system is shown in figure 9. A URT-23 hf transmitter system (with minor modification) is used to translate the output of the sequence generator to an rf signal appropriate for transmission. The 500 kHz BPSK output from the sequence generator is injected into the TP-1 of the T-827 exciter IF strip.

At the receiver site the fundamental components are the HF Adaptive Array Down-Converter (NOSC developed), matched filter, oscilloscope display and the Intel Development System. The down-converter provides the 1.675 MHz IF required by the matched filter. The real time display of the modal structure appears on the oscilloscope. The data collected by the sounder matched filter is stored via the Development System floppy disk for later retrieval and processing.

Table 1. Signal transmission characteristics.

Number	Name	Function	Duration	Message Bits	Sampling Rate	Disk Storage Required
1	CW (Wideband Calibration)	Calibrate WB System	1 sec	—	192 kHz	0.58 M Bytes
2	Comb Sounding	Measure Channel Characteristics	5 sec	—	192 kHz	2.88 M Bytes
3	Impulse Sounding	Measure Channel Impulse Response	5 sec	—	192 kHz	2.88 M Bytes
4	WB QPSK - Data	Analyze WB Algorithms	30 sec	144 K	192 kHz	17.3 M Bytes
5	Impulse Sounding	Measure Channel Impulse Response	1 sec	—	192 kHz	0.58 M Bytes
6	Comb Sounding	Measure Channel Characteristics	1 sec	—	192 kHz	0.58 M Bytes
7	CW (Narrowband Calibration)	Calibrate NB System	1 sec	—	4.8 kHz	14.4 K Bytes
8	NB QPSK - Data	Analyze NB Algorithms	120 sec	576 K	4.8 kHz	1.73 M Bytes
9	Impulse Sounding	Measure Channel Impulse Response	1 sec	—	192 kHz	0.58 M Bytes
10	Comb Sounding	Measure Channel Characteristics	1 sec	—	192 kHz	0.58 M Bytes
11	NB BPSK - Data	Analyze NB Algorithms	120 sec	288 K	4.8 kHz	1.73 M Bytes
12	Impulse Sounding	Measure Channel Impulse Response	1 sec	—	192 kHz	0.58 M Bytes
13	Comb Sounding	Measure Channel Characteristics	1 sec	—	192 kHz	0.58 M Bytes
14	NTDS - Kineplex	Provide Comparison for Algorithm Analysis	120 sec	288 K	4.8 kHz	1.73 M Bytes
15	Impulse Sounding	Measure Channel Impulse Response	1 sec	—	192 kHz	0.58 M Bytes
16	Comb Sounding	Measure Channel Characteristics	1 sec	—	192 kHz	0.58 M Bytes

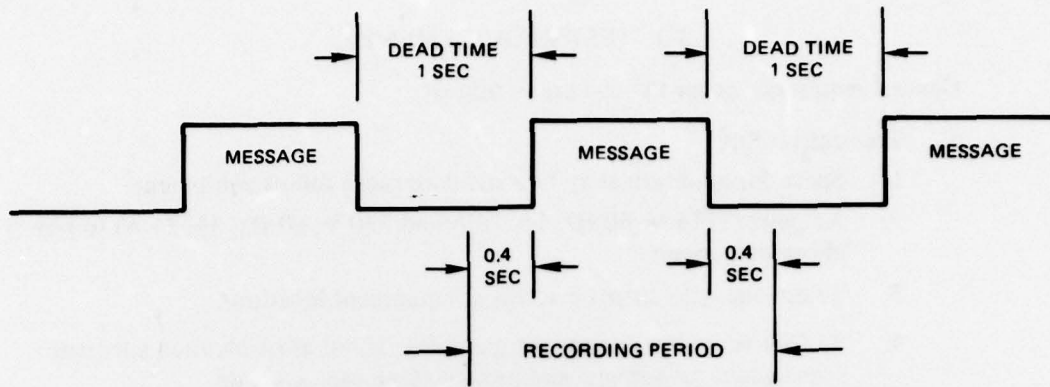
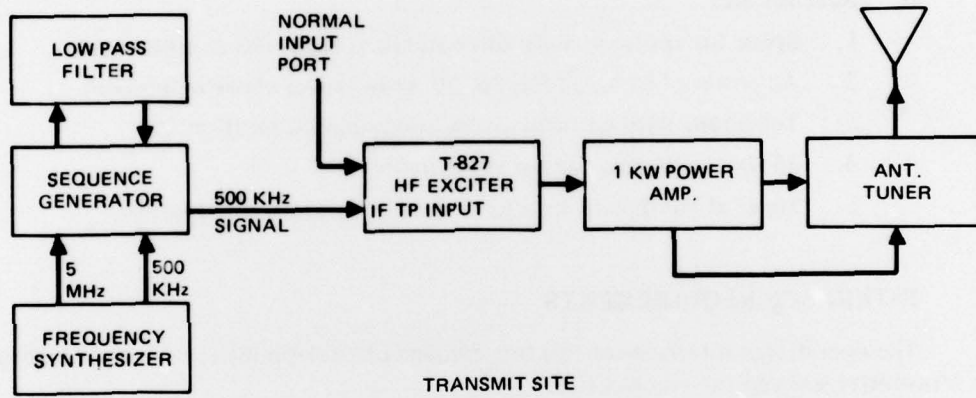
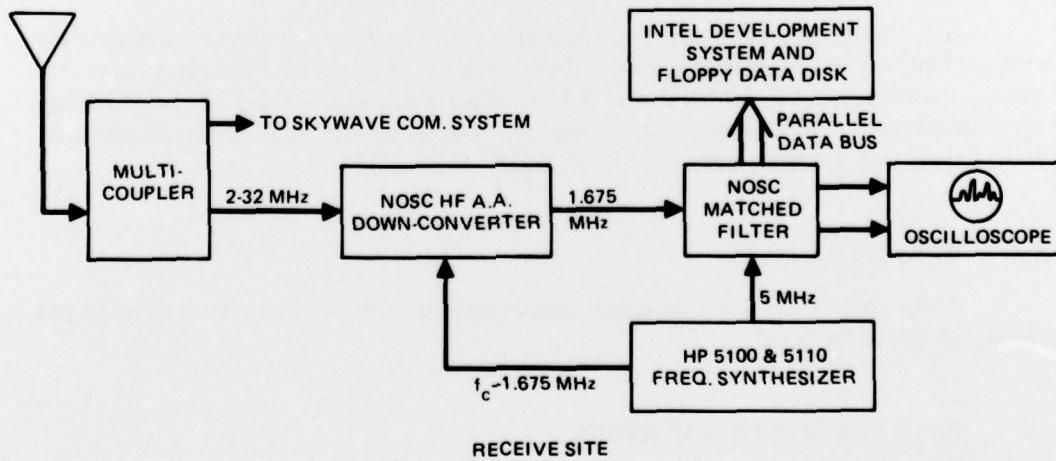

Figure 8. Message recording periods.



TRANSMIT SITE



RECEIVE SITE

Figure 9. HF sounder system.

3.0 TEST REQUIREMENTS

General requirements for the test are as follows:

- a. Transmitter Site
 1. Space for approximately two standard racks full of equipment.
 2. Ac power (115 V, 60 Hz, 1 ϕ , 20 A and 230 V, 60 Hz, 3 ϕ , 25 A) to power above equipment.
 3. Telephone with autovon access at equipment location.
 4. 35 foot whip antenna (or comparable). If not available then adequate space where an antenna and ground plane can be set up.
 5. Minimal help in setting up.
 6. Space at equipment location for data storage and reduction.
- b. Receiver Site
 1. Space for approximately three standard racks full of equipment.
 2. Ac power (115 V, 60 Hz, 1 ϕ , 20 A) to power above equipment.
 3. Telephone with autovon access at equipment location.
 4. 35 foot whip antenna (or comparable).
 5. Space at equipment location for data storage and reduction.

3.1 INTERFACE REQUIREMENTS

The operational interface for this test consists of a telephone (autovon) link between the transmitter site and the receiver site.

3.2 SPECIAL REQUIREMENTS

This test is capable of being conducted on any frequency in the hf spectrum. However, to limit the test, a group of specific frequencies as assigned by the western area frequency coordinator at Point Mugu and NAVCAMS Hawaii will be used. Appendix B lists these frequencies and their designators. Wideband data requires bandwidths of 100 kHz. Narrowband and Kineplex data requires a 3 kHz bandwidth.

3.3 TEST OBJECTIVES

Three specific tests will be conducted as outlined below. These tests must be performed in the order listed.

3.3.1 "BACK-TO-BACK" TESTS

These tests will be conducted at the Laboratory as the final equipment checks before the equipment is moved to the appropriate areas for the field test. Simulation tapes will be generated and used to check data reduction techniques. The objective, of course, is to ensure that the equipment and software are working properly.

3.3.2 "SHORT RANGE" TESTS

These tests will be performed as soon after the back-to-back tests as possible. They will be between Point Mugu, California and NOSC in San Diego, California, a range of 135 nautical miles (155 statute miles). The objectives are as follows:

1. Collect data on the propagation of each "Data" mode
 - a. Wideband QPSK
 - b. Narrowband QPSK
 - c. Narrowband BPSK
 - d. Kineplex
2. Collect data on the HF channel parameters via the "Sounder" modes.
 - a. CW
 - b. COMB
 - c. Impulse
3. Record the noise at the particular frequency and bandwidth of interest at the time each message is transmitted.
4. Later, use the above information to test the performance of the adaptive algorithms and the hf channel simulation model.

3.3.3 "LONG RANGE" TESTS

These tests will be performed several months after the "Short Range" tests and will be between a location on the island of Oahu in Hawaii (tentatively at the NOSC facility at Kaneohe Bay) and San Diego, California, a range of approximately 2270 nautical miles (2611 statute miles). The objectives are identical with those of the "Short Range" tests.

Information on the various "Data" modes can be collected in any order. It is important, however, that adequate "sounding" mode data be taken before and after each "Data" mode run in order to know the hf channel parameter values at the time and how they may be changing.

3.4 TEST EVENTS

Table 2 lists the test events and a brief description of each. Test events 1-5 must precede test events 6-9. Events 1-5 and 6-9 can be performed in any order desired.

4.0 TEST INSTRUMENTATION

Instrumentation for the test events in addition to that shown in figures 4, 6 and 9 consists of the following:

- a. Software for computers
- b. 50 ohm dummy load
- c. Watt meter

Table 2. Test events.

Test Event	Location	Brief Description
1	Laboratory	"Back-to-Back" Checkout of Wideband QPSK Mode*
2	Laboratory	"Back-to-Back" Checkout of Narrowband QPSK Mode*
3	Laboratory	"Back-to-Back" Checkout of Narrowband BPSK Mode*
4	Laboratory	"Back-to-Back" Checkout of Kineplex Mode*
5	Laboratory	"Back-to-Back" Checkout of Sounder Modes and Noise Recording*
6	Point Mugu or Hawaii and San Diego	Gather "On-the-Air" data on Wideband QPSK Mode and Channel Parameters and Noise
7	Point Mugu or Hawaii and San Diego	Gather "On-the-Air" data on Narrowband QPSK Mode and Channel Parameters and Noise
8	Point Mugu or Hawaii and San Diego	Gather "On-the-Air" data on Narrowband BPSK Mode and Channel Parameters and Noise
9	Point Mugu or Hawaii and San Diego	Gather "On-the-Air" data on Kineplex Mode and Channel Parameters and Noise

* Also involves creation of a simulation magnetic tape and checkout of data readout and reduction techniques.

- d. 2 true rms voltmeter (HP3400A)
- e. 50 ohm attenuators
- f. Supply of magnetic tapes
- g. Necessary miscellaneous cabling (for ac power, rf and audio).

5.0 SAFETY REQUIREMENTS

No unusual safety hazards are known to exist.

6.0 SECURITY REQUIREMENTS

The security classification of all test equipment, test data, and test results is UNCLASSIFIED.

7.0 REFERENCES

1. Naval Ocean Systems Center Technical Report 210, "Skywave Communication Techniques: A Status Report for FY77," by L. E. Hoff, December 1977.
2. Mitre Corporation TM04101, ESD-TDR-64-631, "Comparative Performance Evaluation of Digital Data Modems for HF Radio," by R. E. Grein, W. R. Menges, F. N. Nelson, Jr.
3. Naval Electronics Laboratory Center Report 1634, "Error Rate Observed on HF Multichannel Fleet Broadcast System," by G. B. Johnson and G. P. Francis, 28 July 1969.
4. Naval Electronics Laboratory Center Report 1686, "Error Control in HF Fleet Broadcast System," by J. L. Heritage, 10 February 1970.
5. Naval Ocean Systems Center Technical Report 208, "HF Channel Simulator for Wideband Signals," by R. Lugannani, H. G. Booker, and L. E. Hoff, March 1978.
6. Naval Ocean Systems Center, Addendum 1 to Technical Report 208, "HF Channel Simulator for Wideband Signals," by R. Lugannani, H. G. Booker, and L. E. Hoff, November 1978.

APPENDIX A: MAGNETIC TAPE FORMAT AND LABELING*

Three types of magnetic tape recordings will be made: (1) the field test data tape which will contain information on one of the "data" mode transmitted signals as described in section 2.4; (2) the field test sounding tape which contains information from the "sounder" modes of the transmitted signal (see section 2.4); and (3) simulation tapes which are created in the laboratory and used for system checkout and evaluation.

Figure A1 shows the formats for these three types of recordings. Each tape will consist of first a parameter block (described below) and then data blocks which are separated by one or more null blocks. The field test data tapes will contain only one "message" and data blocks will follow immediately after the null block. Since data is recorded for 0.4 seconds before and after each "message" (see figure 8), the first and last few blocks will contain noise only. For the field test sounding tape, several "messages" will be on a tape. Each message is separated by a null block. Again the first and last few blocks of each "message" section will be noise only. In the simulation test tape an extra possible null block has been added before and after each "message." If the simulation tape is signal only (no noise), these blocks will be null. If the tape includes noise, these blocks will be noise only.

As previously mentioned, the first block recorded on any of the tapes is a parameter block which contains labeling and identification information pertinent to the tape. First will be information about parameters common to all types of tapes. Next will be information about the transmitted message, then channel parameters, field test parameters and finally noise parameters. All of this information is amplified in Table A1.

* Information in this appendix is extracted from NOSC Memorandum Serial No. 814/28, dated 27 June 1979 from Allen Heaberlin.

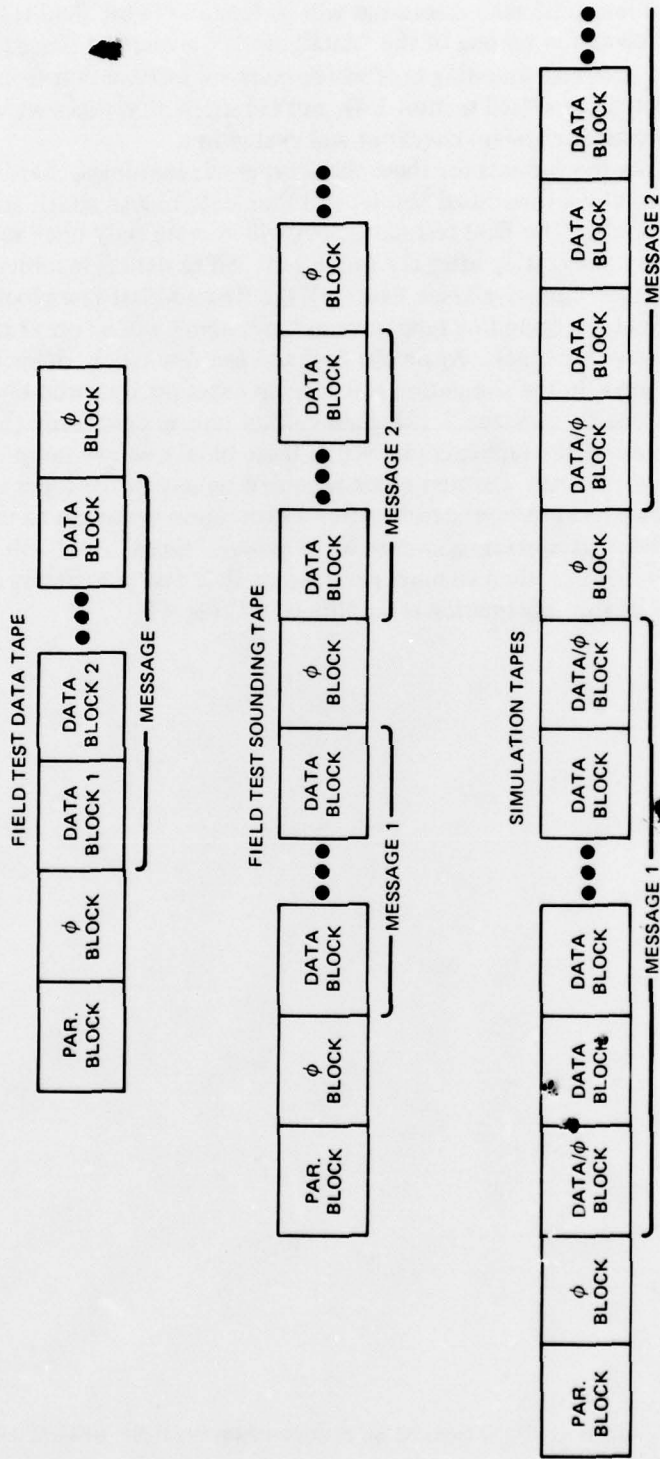

Figure A1. Tape formats.

Table A1. Parameter Block Description

A. Common Parameters

1. Date
 - a. Word 1 – Day
 - b. Word 2 – Month
 - c. Word 3 – Year
2. Time
 - a. Word 4 – Seconds
 - b. Word 5 – Minutes
 - c. Word 6 – Hours
3. Word 7 – Type of tape
 - a. 1 = Simulated
 - b. 2 = Field Test
4. Word 10 – Type of signal on tape
 - a. 1 = BPSK data
 - b. 2 = QPSK data
 - c. 3 = Kineplex data
 - d. 4 = sounding
 - e. 5 = Noise
5. Word 60 – Bandwidth
 - a. 1 = Wideband
 - b. 2 = Narrowband
 - c. 3 = Wideband/Narrowband – both bandwidths are on tape
6. Word 70 – Number of blocks on tape

B. Transmission Parameters (These apply to the data tape, field test tape and the simulation tape)

1. Word 20 – Number of messages on tape
2. Word 30, 31 – Number of binary digits in each message
3. Random number seeds for narrowband
 - a. Word 40 – least significant 16 bits
 - b. Word 50 – most significant 16 bits
4. Random numbers seeds for wideband
 - a. Word 80 – Least significant 16 bits – data random number
 - b. Word 90 – Most significant 16 bits – data random number
 - c. Word 100 – Least significant 16 bits – chip random number
 - d. Word 110 – Most significant 16 bits – chip random number
5. Word 120 – Number of blocks per message
6. Word 130 – Sampling rate

Table A1. (Continued)

- C. Channel Parameters (These apply only to the Simulation tape)
1. Date channel tape created (channel simulation tape only)
 - a. Word 301 – Day
 - b. Word 302 – Month
 - c. Word 303 – Year
 2. Time channel tape created (channel simulation tape only)
 - a. Word 306 – Seconds
 - b. Word 307 – Minutes
 - c. Word 308 – Hours
 3. Word 310 – Antenna Type
 4. Word 315 – Sea state
 5. Word 320 – Longitude
 6. Word 322 – Latitude
 7. Word 330 – Output data scaling values (Since data is in integer format the data on the tape was scaled. This is the scaling value.)
 8. Channel Parameters from Channel Simulator (All below are real numbers and thus two words are required.)
 - a. Word 341, 342 – Sunspot number
 - b. Word 343, 344 – Solar Zenith angle
 - c. Word 345, 346 – E region height of maximum electron density
 - d. Word 347, 348 – E region semithickness of Parabola
 - e. Word 349, 350 – E region penetration frequency, ordinary wave
 - f. Word 351, 352 – E region penetration frequency, extraordinary wave
 - g. Word 353, 354 – E region temperature at height of maximum electron density
 - h. Word 355, 356 – F region height of maximum electron density
 - i. Word 357, 358 – F region semithickness of parabola
 - j. Word 359, 360 – F region penetration frequency, ordinary wave
 - k. Word 361, 362 – F region penetration frequency, extraordinary wave
 - l. Word 363, 364 – F region temperature at height of maximum electron density
 - m. Word 365, 366 – Collision frequency constant – exponent of first additive term
 - n. Word 367, 368 – Collision frequency constant – multiplicative constant
 - o. Word 369, 370 – Collision frequency constant – shift constant
 - p. Word 371, 372 – Collision frequency constant – multiplicative constant of second term
 - q. Word 373, 374 – Nondeviate absorption constant – multiplicative constant
 - r. Word 375, 376 – Nondeviate absorption constant – sunspot number multiplier
 - s. Word 377, 378 – Nondeviate absorption constant – solar zenith angle exponent
 - t. Word 379, 380 – Doppler reference values, E region – shift
 - u. Word 381, 382 – Doppler reference values, E region – shift exponent
 - v. Word 383, 384 – Doppler reference values, E region – spread
 - w. Word 385, 386 – Doppler reference values, E region – spread exponent
 - x. Word 387, 388 – Doppler reference values, E region – reference frequency
 - y. Word 389, 390 – Doppler reference values, F region – shift
 - z. Word 391, 392 – Doppler reference values, F region – shift exponent

Table A1. (Continued)

- aa. Word 393, 394 – Doppler reference values, F region – spread
- bb. Word 395, 396 – Doppler reference values, F region – spread exponent
- cc. Word 397, 398 – Doppler reference values, F region – reference frequency
- dd. Word 399, 400 – Doppler reference values, F region – shift
- ee. Word 401, 402 – Doppler reference values, F region – shift exponent
- ff. Word 403, 404 – Doppler reference values, F region – spread
- gg. Word 405, 406 – Doppler reference values, F region – spread exponent
- hh. Word 407, 408 – Doppler reference values, F region – reference frequency
- ii. Word 409, 410 – Groundwave delay
- jj. Word 411, 412 – Groundwave attenuation
- kk. Word 413, 414 – Number of paths

9. Individual path parameters from channel simulator. Each path will use 30 words with only path 1 described below. The other paths are identical except the word numbers are different.

- a. Word 421, 422 – Mode
- b. Word 423, 424 – Solution Indicator
- c. Word 425, 426 – Ray angle
- d. Word 427, 428 – Path length
- e. Word 429, 430 – Carrier delay (seconds)
- f. Word 431, 432 – Carrier phase (cycles)
- g. Word 433, 434 – Signal delay (seconds)
- h. Word 435, 436 – Amplitude distortion (sec/MHz)
- i. Word 437, 438 – Phase distortion (sec/MHz**2)
- j. Word 439, 440 – Attenuation (dB)
- k. Word 441, 442 – Doppler shift (Hz)
- l. Word 443, 444 – Doppler spread (Hz)

Note: Path two uses words 451 to 474, path three uses 481-504 etc.

D. Field Test Parameters

- 1. Word 601 – Frequency of receiver

E. Noise Parameters (Noise tape only)

- 1. Word 901 – Receiver Frequency (If zero, noise is computer generated)
- 2. Word 906 – How data was obtained
 - a. 1 = direct digital recording
 - b. 2 = through wideband tape recorder
- 3. Word 910, 911 – Random number seeds. (Only used for computer generated noise tapes.)

APPENDIX B: TEST DESIGNATORS AND FREQUENCIES

Point Mugu Test		Hawaii Test	
Designator	Frequency (MHz)	Designator	Frequency (MHz)*
A	4.5	A	2.0
B	5.9	B	3.0
C	6.8	C	4.0
D	9.3	D	5.0
E	11.5	E	6.0
F	15.6	F	8.0
G	16.0	G	10.0
H	20.1	H	12.0
		I	14.0
		J	16.0
		K	19.0
		L	23.0

These frequencies have a 6 kHz bandwidth assignment.

This appendix may be modified as required by the test engineer and an appropriate operation order.

* A specific frequency in each range will be assigned by the appropriate agency prior to the Hawaii test.