

AD-A080 224

MARTIN MARIETTA AEROSPACE ORLANDO FL
U.S. ARMY MANUFACTURING METHODS AND TECHNOLOGY PROGRAM COVERING--ETC(U)
SEP 79 F E TARTAGLIA
OR-15415

F/6 9/1
DAAK40-76-C-0452
NL

UNCLASSIFIED

1 OF 2
AD A
080224

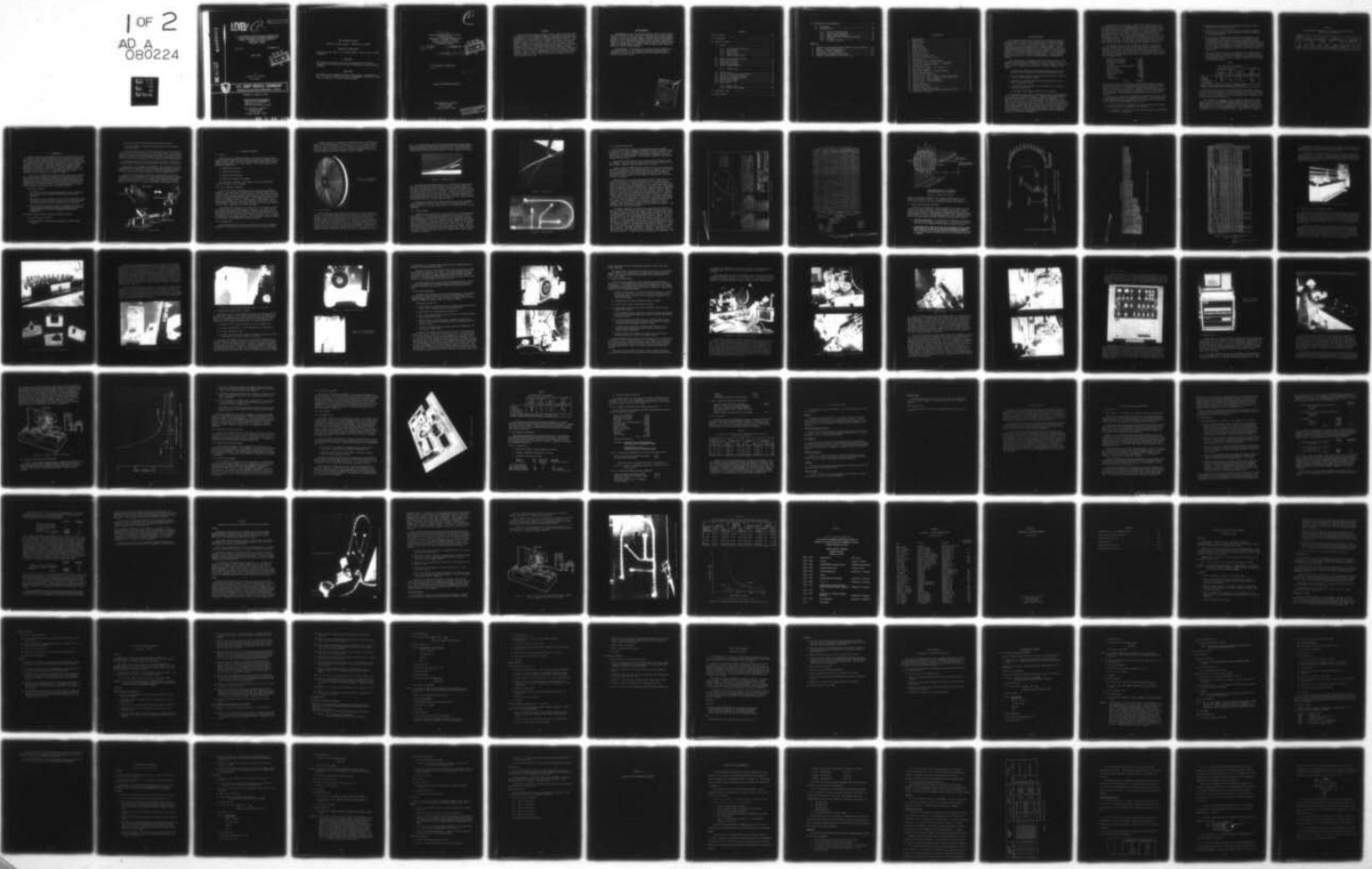

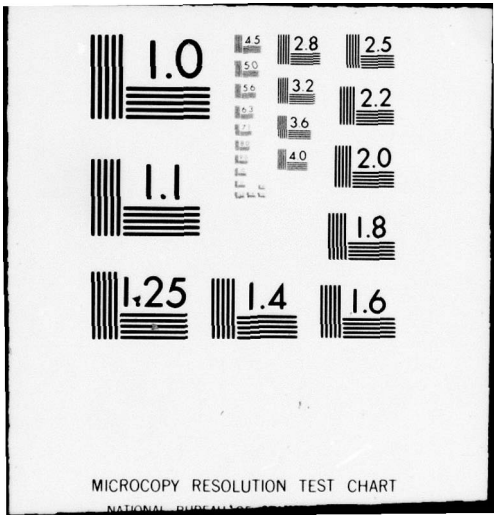

ADA 080224

DDC FILE COPY

LEVEL

P

AD

U.S. ARMY MANUFACTURING METHODS AND TECHNOLOGY STUDY
COVERING APPLICATION OF AUTOMATED MANUFACTURING
PROCESS TO METHODS FOR AFFIXING ELECTRICAL
CONNECTORS TO CABLES
(Project No. 3091)

OR 15,415

SEPTEMBER 1979

FINAL REPORT

DDC
FEB 4 1980
E

by
Frederick E. Tartaglia
Task Leader



U.S. ARMY MISSILE COMMAND

Redstone Arsenal, Alabama 35809

CONTRACT NO. DAAK40-76-C-0452

This document has been approved
for public release and sale; its
distribution is unlimited.

Martin Marietta Corporation
Orlando Division
P.O. Box 5837
Orlando, Florida 32855

80 1 28 159

DDC AVAILABILITY NOTICE

Approved for public release. Distribution unlimited.

DISPOSITION INSTRUCTIONS

Destroy this report when it is no longer needed. Do not return it to the originator.

DISCLAIMER

The findings in this report are not to be construed as an official Department of the Army position, unless so designated by other authorized documents.

TRADE NAMES

The citation of any commercial products, trade names, or manufacturers in this report does not constitute an official endorsement or approval of such items or companies by the United States Government.

C

6 U.S. Army
Manufacturing Methods and Technology
Program Covering
Application of Automated Manufacturing
Process to Method for Affixing
Electrical Connectors to Cables
(Project No. 3091)

14 OR-15,415

11 September 1979

DDO
R
FEB 4 1980
E

9 Final Report, Jan 76-Feb 79

10 Frederick E. Tartaglia

12 158

15 Contract No. DAAK40-76-C-0452

Martin Marietta Corporation
Orlando Division
P.O. Box 5837
Orlando, Florida 32855

This document has been approved
for public release and sale; its
distribution is unlimited.

403 238

JOB

FOREWORD

Martin Marietta Aerospace, Orlando, Florida, submits this final report to Headquarters, U.S. Army Missile Command in compliance with contractual requirements of Contract DAAK40-76-C-0452 and Modification P00001-5. This program goal was to implement the recommendations obtained from an earlier conceptual study (contract DAAH01-74-R-1069). The earlier work was presented in reports OR 13,354 through 13,354-4, which covered an industry study of harnesses and equipment and developed a concept for the mechanized assembly of harnesses. The program reported here covered the period January 1976 through February 1979. This work was essentially completed at the end of August 1978, but the program was held open to February 1979 to complete a study on internal implementation and to complete other efforts warranted during that time. Reports issued on this program include OR 14,151 through OR 14,151-8.

ACKNOWLEDGEMENTS

Acknowledgement is given to the many technical people within industry whose participation through conferences and surveys has contributed significantly to the success of this program. Contributions by Martin Marietta personnel are also acknowledged: Messrs. Herbert L. Sullivan and Eugene R. McGowen, for their important participation in the Machinery Laboratory as members of the task team, Mr. Alexander Nikalaiev for his successful development and implementation of a complex control system, and Mr. Richard P. Malena for overall program guidance.

Acknowledgement is also given to Mr. Richard A. Kotler, MICOM Technical Representative, for his assistance and technical contributions throughout the course of the program, and for his counsel and advice at significant decision points.

Accession For	
NTIS GEN&I	
DEC TAB	
Unannounced	
Justification	
By	
Distribution/	
Availability Codes	
Dist	Avail and/or special
A	

CONTENTS

Executive Summary vii

1.0 Introduction 1

2.0 Technical Approach 3

 2.1 General 3

 2.1.1 Wire Preparation Equipment 3

 2.1.2 Standard Reel 3

 2.1.3 Wire Carrier 4

 2.1.4 Sample Harness 5

 2.1.5 Harness Assembly Data 7

 2.2 Manual Wire Preparation Facility 10

 2.3 Harness Tooling Board 14

 2.4 Terminated Wire Reeler 17

 2.5 Reel-to-Reel Sequencer 19

 2.6 Harness Assembly Machine 21

 2.6.1 Control System 26

 2.7 Harness Tying 27

 2.8 Facility Coordination and Verification 29

 2.9 Documentation and Specifications 31

 2.10 Operational Procedures Handbook 31

 2.11 Harness Design Handbook 31

 2.12 Facility Scale Model 32

 2.13 Cost Studies 32

 2.13.1 Manpower Only 32

 2.13.2 Manpower and Equipment 32

3.0 Deliverable Items 37

4.0 Program Results 39

5.0	Conclusions and Recommendations	41
5.1	Conclusions	41
5.2	Recommendations	42
5.2.1	Executive Software Program	42
5.2.2	Insertion Head Adaptation	43
5.2.3	Graphic Design Development	43
5.2.4	Upgrade Wire Capture and Handling System	44
5.2.5	X-Y Table	44
5.2.6	Equipment Availability	45

APPENDIXES

A	Comparison of Manual and Automatic Machine Tying of Harnesses .	A-1
B	Agenda - Industry Demonstration	B-1
C	Attendees - Industry Demonstration	C-1
D	Operational Procedures Handbook	D-1
E	Harness Design Recommendation Handbook	E-1
F	Drawings, Documentation, and Specifications	F-1

ILLUSTRATIONS

1	System Concept	2
2	Standard Reel	4
3	Channel Carrier	5
4	Tape Carrier	6
5	Sample Harness	6
6	Harness Drawing	8
7	Harness Data Sheet	9
8	Connector Data Sheet	10
9	Harness Path Data	11
10	Subroutine Data Plot	12
11	X-Y Table Programming Data	13
12	Manual Wire Preparation Facility	14
13	Tooling Board	15
14	Tooling Board Latch and Guide Elements	15
15	Tooling Board Connector Fixture - Down Position	16
16	Tooling Board Connector Fixture - Up Position	17
17	Terminated Wire Reeler	18
18	Terminated Wire Reeler - Entry Mechanism	18
19	Reel-to-Reel Sequencer	20
20	Reel-to-Reel Sequencer - Transfer Mechanism	20
21	Harness Assembly Machine	22
22	Dispensing and Insertion Unit	23
23	Insertion Head - Quill in Pickup Position (Front View)	23
24	Insertion Head - Quill in Pickup Position (Back View)	24
25	Insertion Head - Pickup Complete	25
26	Insertion Head - Reversing Mechanism	25
27	Control Console	26
28	System Microprocessor	27
29	Manual Harness Tying	28
30	Automatic Harness Tying Concept	29
31	Comparison of Manual and Automatic Harness Tying Costs	30
32	Scale Model of Facility	33

EXECUTIVE SUMMARY

This program was initiated to implement the findings of a previous contract, DAAH01-74-R-1069, entitled "Application of Automated Manufacturing Process to Methods for Affixing Electrical Connectors to Cables." The objective of the first contract was to develop a concept for mechanizing the processes associated with wire harness assembly. This entailed separating and identifying each of the individual harness assembly processes and developing concepts of machines capable of performing those operations. The initial program developed a concept for the handling of wires and connectors into a harness configuration. It also documented general specifications for a set of machine modules to demonstrate the concept.

The following pieces of equipment resulted from that effort: terminated wire reeler; harness sequence reeler; wire-to-connector inserter; and X-Y table tooling board. In addition to machine concepts, the following activities were completed, which would aid in harness assembly mechanization.

- 1 A study was completed which determined that manual tying of the harness proved to be more cost effective than automatic tying.
- 2 Wire and connector specifications were developed which would facilitate automated assembly procedure.
- 3 Handbooks for harness design and operating procedures were prepared (Appendixes D and E).
- 4 A scale model depicting each item of equipment in the automated system was fabricated.
- 5 A videotape of the complete process flow was prepared.

A new program was initiated to implement this concept and demonstrate the feasibility of proposed processes. A sample Pershing missile harness was selected and adapted to the mechanized methods recommended. The wires selected were 20-, 22-, and 24-gage NAS 702 stranded wires with a PVC insulation and a clear nylon outer sheath. The connectors were Deutsch series 30DBA, environmental type with loose pin, rear entry, straight backshell, and a resilient rear wafer. These wires and connectors were selected for compatibility, since the mechanized concept was not intended to process shielded wires or twisted pairs. When these or other incompatible wires were required, they were installed manually, after the mechanized portion of the process was complete.

A sequence (wire running list) was developed for dispensing each of the respective wires in a programmed fashion. This required identifying the required control system and developing the actual N/C program. Equipment was designed and fabricated that would cut, strip, and trim the wires that were not suited for automatic operations to a predetermined length. The terminated wire reeler and the harness sequence reeler were then designed and built. These items of equipment prepared the wire reels for the assembly process. The final piece of equipment completed was the harness assembly machine. The equipment is used to dispense the wire per the wire running list onto a tooling board representing the harness configuration and then inserting the wire leads into the appropriate connectors.

All equipment and tooling was documented, and sets of drawings were prepared and sent to MICOM as part of the final contract requirements. Each item of equipment was fabricated and installed in a facility. The prototype facility was checked out and several trial harness assembly runs were made, which resulted in fabrication of successful harnesses. The total nonrecurring equipment and material costs for duplication of this system are as indicated below:

Manual wire preparation	\$ 5,000
Terminated wire reeler	12,000
Reel-to-reel sequencer	30,000
X-Y table	44,000
Automatic wire dispensing machine	22,000
Microprocessor	22,000
Control system	30,000
Tying tool rental	300
Reels, racks, tapes	8,000
Facilities	10,000
Tooling	6,000
Miscellaneous	700
Total	\$ 190,000

Recurring cost studies were performed on fabricating harnesses utilizing three facility modes: 100 percent manual, 100 percent automatic, and 80 percent automatic/20 percent manual. Harnesses fabricated on both the 100 percent automatic and 80 percent automatic/20 percent manual facilities show a percent of manual savings of approximately six to one and four to one respectively. Harness fabrication and setup times are indicated in Table I.

The next cost comparison encompassed varying harness production levels and amortization of each of the three facility modes. Table II shows that at the 15,000 production level and above, the savings of 80 percent mechanized processing are approximately four to one.

To fully develop this technology in a production mode, the following activities would require investigation and completion:

- 1 Development of an executive software program capable of programming any harness configuration.

- 2 Identification and fabrication of multipurpose adapters capable of inserting wires in various connectors.
- 3 Incorporation of the wire harness design and fabrication sequence into the CAD/CAM system to reduce the cost and time of preparation of the wire running list.
- 4 The present wire handling and storage system is cumbersome, since it was designed to take prepared wires of a single gage from an existing machine and process them through staging and coordination to the final assembly process. This system could be greatly improved by development of an automatic wire preparation system that would measure, cut, strip, and terminate the required wire and feed it directly into the assembly machine without the reels, Velcro tape, staging, or coordination.
- 5 The size of the X-Y table must be considered in any future production module designs. Careful determination of the proper table size is necessary when selecting an X-Y assembly unit, to ensure that the optimum working area is selected to process the harness sizes planned for mechanized assembly.

TABLE I

Total Run-Time Cost Analysis

	Run Time per 100 Units (Hours)	Run Time per Unit (Hours)	Setup Time (Hours)	Percent of Manual (Excluding Setup)
Manual	2303	23	4.0	100
Automatic	328	3.3	2.0	14.35
80% Automatic/ 20% manual	500	5.0	2.4	21.75
Basis: Sample demonstration harness in 100-unit lots				

With these five areas of effort accomplished, the equipment could be phased into a production plan for reliable fabrication of harness assemblies. To fully develop and implement the work described in items 1 through 5 above, one-time costs of 91 manmonths of effort and approximately \$138,000 would be required for equipment and software.

The program is now complete, with all equipment documented and implemented. The total complement of equipment demonstrated in the full scale engineering prototype facility and the associated documentation are currently available on a no-cost loan basis from the Government for additional development or for production implementation. Any company involved in Government contract work is eligible to submit a request for this equipment.

TABLE II

Cost Comparison of Manual versus Automatic Harness Processing
(Total Costs in Dollars)

Harness Production Quantities (3 x Mis- sile No.)	MPP Costs Section 3		Equipment Usage Cost Section 2		Manpower Costs Sections 4 and 5		Total Burdened Assembly Costs		
	Manual	Auto- matic	Manual	Auto- matic	Manual	Auto- matic	Manual	Auto- matic	20/80
150	1,120	7,000	25,237	128,175	124,862	19,162	1,008	1,029	1,024
1,500	1,120	7,000	25,237	128,155	1,227,625	181,125	836	210	335
15,000	1,120	7,000	50,715	247,995	12,092,500	1,723,750	810	122	267
150,000	1,120	7,000	451,950	2,216,650	120,925,000	1,723,500	809	130	266

1.0 INTRODUCTION

Harness fabrication is recognized as one of the major missile system cost drivers. Recent studies and seminars have pointed out the need for more economical and reliable methods for harness and cable construction. The cost of manufacturing these cables and harnesses for the missile industry remains high, while other missile fabrication processes are being upgraded and streamlined. Mechanized processes and standardization of materials are resulting in less expensive and more reliable products throughout the industry -- except in the cable and harness areas. Here, the manual process persists, to a large degree, and the variety of materials used are cumbersome and complex to handle.

In June 1974, a program was initiated at Martin Marietta to investigate existing harness fabrication practices and to develop concepts for improving the harness manufacturing process and reduce production costs. This program entitled "Application of Automated Manufacturing Process to Methods for Affixing Electrical Connectors to Cables," was funded under MICOM Contract No. DAAH01-74-R-1069. The program consisted of a three-phased 12-month basic program, with a two-month extension.

The program covered:

- 1 The survey and study of harnesses and cables used in current missile systems, and the equipment available to process these harnesses.
- 2 The evaluation of the component parts of these harnesses and cables (connectors, wires, ties, etc.), and the study of specifications and restrictions that control the fabrication of these parts.
- 3 The development of a design concept for a mechanized facility for fabrication of harnesses and cables, using manual interfaces for those operations that cannot be mechanized practically or economically.

The further study, during the two-month extension, covered:

- 1 The presizing of the wires
- 2 Western Electric custom assembly machinery for usable design principles

- 3 The more complex stripping methods that might be applied
- 4 The application of soldering of crimp contacts in the conceptual facility design.

After an in-depth study of the processes involved, a basic approach to a total capability harness fabrication facility was defined. This concept proposed the presizing and termination of the harness in a sequenced order, storage in sequence on reels in a staging area, and the subsequent dispensing of the wires onto a tooling board in a specified harness configuration.

Further development of this basic approach resulted in fabrication of tabletop hardware that proved the feasibility of key points of the concept.

Block process flow diagrams were prepared, and the mechanized and manual operations were identified. Machine modules were defined and recommendations made to design and fabricate a simplified engineering prototype facility to demonstrate system feasibility and make experimental runs.

The current program effort was directed toward design, fabrication, and operation of the recommended full scale engineering prototype equipment to demonstrate the feasibility of the previously developed mechanization concept. The modules built on this program were components of a developmental facility (Figure 1), so were not intended to be production units.

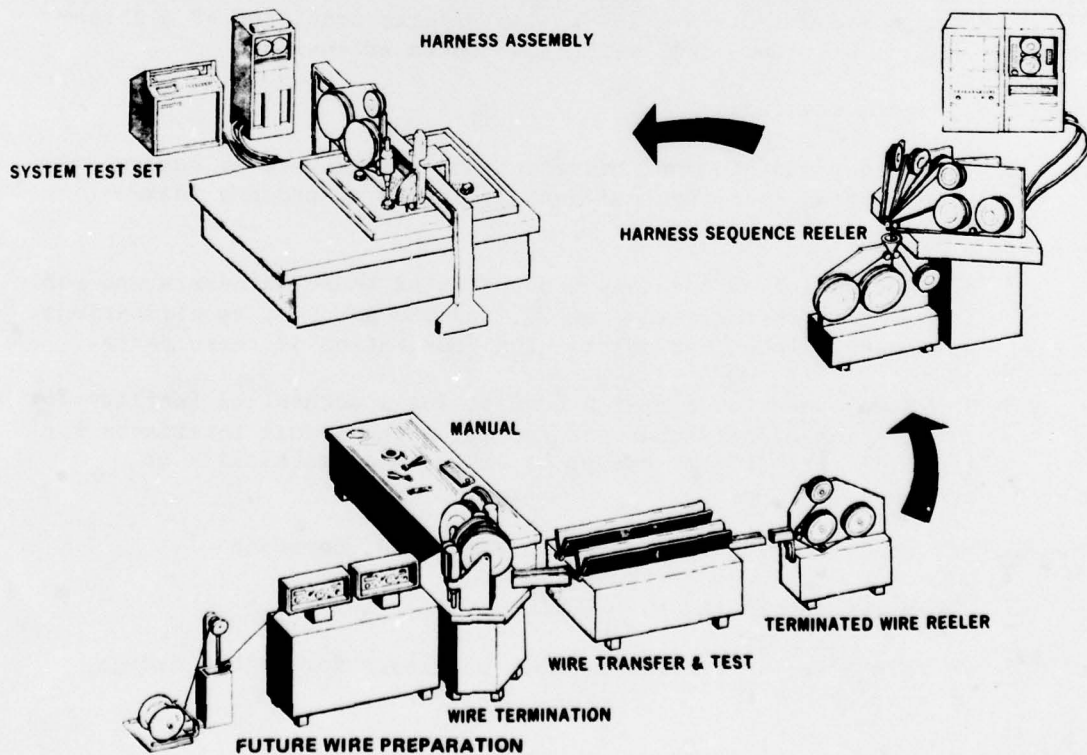

Figure 1. System Concept

2.0 TECHNICAL APPROACH

2.1 General

Each of the basic machines described in the previous harness study program (Reference Contract Number DAAH01-74-R-1069) were designed with the system concept in mind. Full scale prototype models were built to demonstrate the capability of the total facility. The following machines were designed and fabricated:

- 1 Terminated wire reeler
- 2 Reel-to-reel sequencer
- 3 Harness assembly machine
- 4 Manual wire preparation equipment.

The activities undertaken, with respect to each of the machines pictured in Figure 1, are as stated.

2.1.1 Wire Preparation Equipment

First in the harness fabrication facility is the wire preparation equipment. Here the wires are prepared to the scheduled length, with the proper terminals, and in the correct sequence. The initial plan was based on the use of an existing automatic wire preparation machine that could be rented or purchased from outside industry. This machine could take a reel of wire of 20 gage, 22 gage, or 24 gage, and by a preprogrammed control system measure, mark, cut, strip, and terminate the wire with a choice of three different terminals at each end. The wires could be of any length up to 1000 inches, according to the required program.

This machine was available at the beginning of the program, but when the overall system coordination phase was started it was found that the unit had been withdrawn from the market. Inquiries were made and it was discovered that there had been no requirement for a machine with this type of flexibility at the costs involved. Further requests on costs or timing to produce one of the machines were met with no interest, thus that portion of the facility was designated as a manual interface.

2.1.2 Standard Reel

To handle the wires and control the passage of the wires through the equipment, a standard reel was required that could be used universally.

A standard plastic reel flange was purchased for use as a base to the reel. A flat surface was cast in epoxy on the face of the reel to obtain a reference plane for subsequent reel alterations. A drive design was developed with a drive plate and a face key. This provided an accurate reel with a universal drive that could be mounted on all components and provide reliable handling of the wires (Figure 2, Dwg No. E10200).

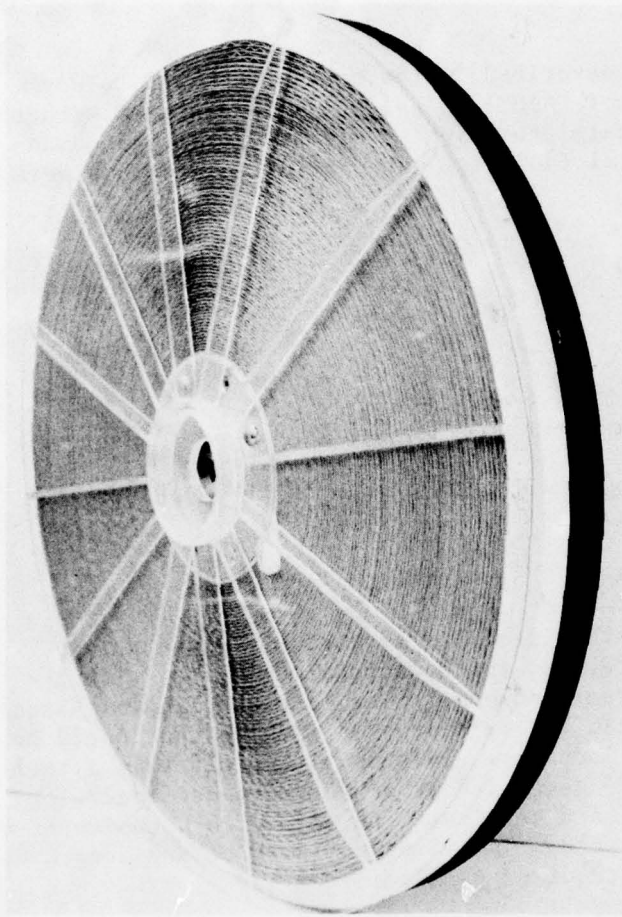

Figure 2. Standard Reel
(Dwg. No. E10200)

2.1.3 Wire Carrier

Since the presized and terminated wires were to be stored on reels in sequence, a method was required that would capture and control these wires from the time they were initially fed into the system, through all the transfers, until they were deposited on the tooling board. The initial concept attempted was the positioning of the wires in a rubber channel and covering them with a top liner (Figure 3). This sandwich was then wound on the reel and stored for later use. During the unwinding operation, the linear speed was controlled by running the liner through a capstan drive on a stepping motor. The tension and the slack control were maintained by means of an ELINCO GLJRN1015 torque motor that put a resisting force on the

reel. The inertia loads on the reel during starting and stopping operations were beyond the capability of the torque motor, and slack conditions occurred during high inertia times during the cycle. This allowed the channel-liner carrier to open and release the wire, jamming the equipment.

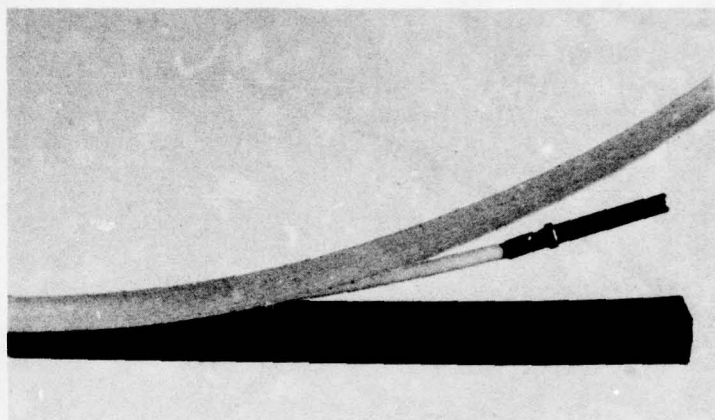

Figure 3. Channel Carrier

The second concept examined the use of a 5/8-inch wide Velcro zipper tape which captured the wires between the two tape surfaces (Figure 4). The wire was entrapped within the zipper, and control was retained until the zipper tape was forced open. However, one problem did develop with the closed loop (pile) side of the Velcro tape: when one of the pin terminals of the wire caught in one of the tape loops, it followed the tape out of the operating area and into the receiving drum. This was corrected by cutting a 1/8-inch groove down the center of the closed nylon loops by melting the material away with a 1/8-inch wide hot blade.

The system now works with extreme reliability, and later development should increase the 300-foot reel capacity by at least 400 percent by widening the reel, since the rigid control of the single width is no longer necessary.

2.1.4 Sample Harness

A sample harness was selected for demonstration of the mechanized concept (Figure 5). This demonstration harness was an adaptation from the Pershing missile that retained configuration, but was reduced in size to fit the prototype 24 by 48 inch X-Y layout table. Components compatible with the mechanized concept were selected and substituted for the original parts. The harness contains 106 wires, with a mix of No. 20, 22, and 24 gage distributed evenly from each connector to every other one. The wire is NAS702 with a PVC insulation and a clear nylon outer sheath. The connectors are Deutsch series No. 30 DBA environmental type. The control sample shown in Figure 5 was constructed on a standard tooling board, using traditional procedures.

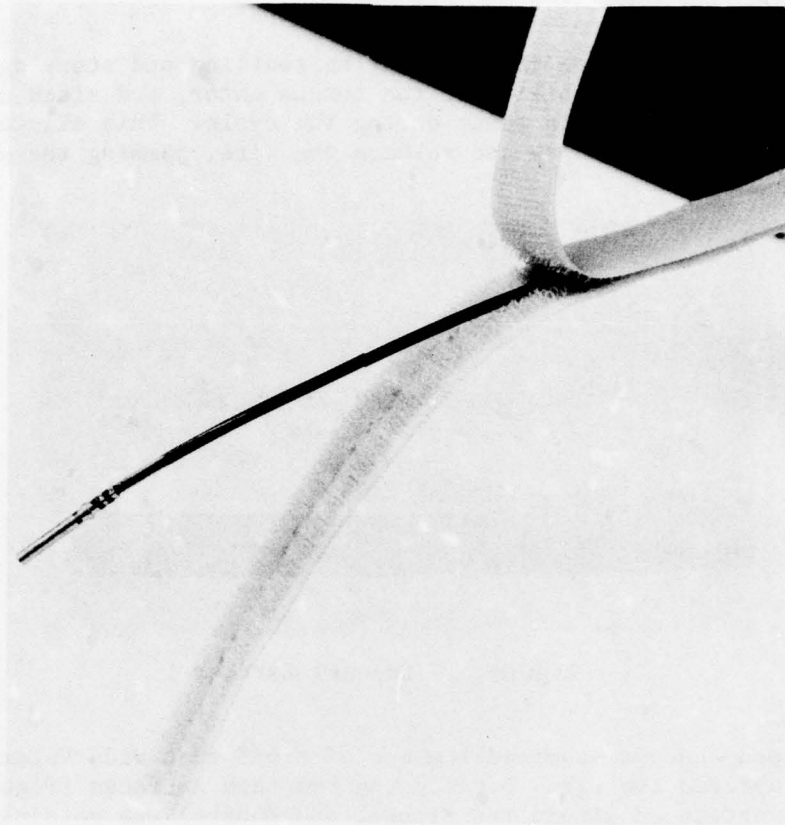

Figure 4. Tape Carrier

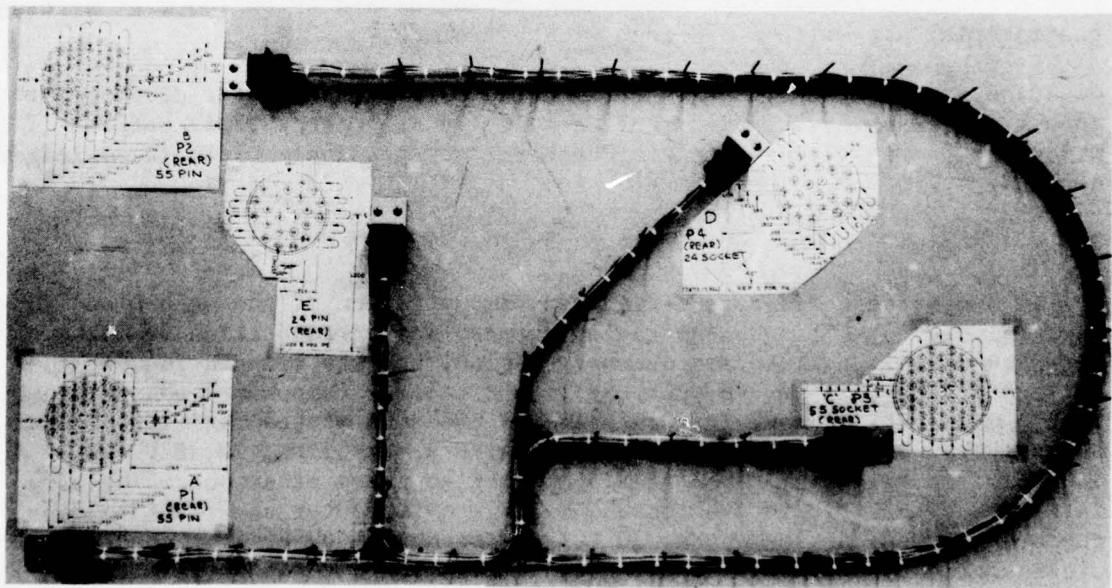

Figure 5. Sample Harness

2.1.5 Harness Assembly Data

The procedure used to set up the program data for this assembly started with the detailed drawing of the harness (Figure 6, Dwg No. C40007). In addition to the basic information delineating the size and shape of the harness, the wire specifications are given and the connectors are specified, along with their terminals. The connector orientation and insertion sequence are also noted.

The second form developed was the harness data sheet (Figure 7, Dwg No. E40008). This form lists the wires in the order of use (sequence), the gage, length, terminals, and the primary reel to be used.

Figure 8 (Dwg No. F40009) depicts the layout of one of the connectors, showing the orientation of the keyway opposite to the harness wires running into it, the positions of the pin cavities, and the order of insertion. The insertions start at the cavities nearest the wire run and proceed through the connector pattern so that insertions always occur in the open area of the connector.

The positioning of the X-Y table and the connector always starts at a preliminary point on the harness centerline and 1 1/2 inches from the center of the connector. From this point the final insertion position is taken each time the X-Y table completes its run. Another data sheet shows the X-Y coordinate points of the wire paths: numerical control information depicting machine motions was developed and documented using the lower left corner of the tooling board as the zero point (Figure 9, Dwg No. F40009). Using this zero point, the harness runs are documented with X-Y coordinate points to delineate all straight paths and curves, made up of a series of straight paths. Each wire run begins and ends at a preliminary data point 1 1/2 inches from each connector. In this manner, repetitive wire-laying paths can be set up between any two connectors. These paths were defined as a series of X-Y coordinates, so they could be stored as a block of information and called up as a single subroutine (Figure 10, Dwg No. F40009). These subroutines were set up for each path on the harness, thus simplifying the final harness program.

The table programming is the final data sheet developed (Figure 11, Dwg No. F40009). Here the wires are again listed in order of use. Next, the harness connectors (P1-P5) are listed. After the plug listing columns, the starting point, wire path, and finishing point are listed. Now the cycling sequence listing is developed and, as shown in Figure 11, the program starts at the 0, 0 table position and moves to plug No. 2, pin position No. 47. After the end of the wire is inserted in position No. 47 of Plug No. 2, the program moves the X-Y table to the preliminary data point for plug No. 2, where it picks up the B-to-A subroutine (plug No. 2 to plug No. 1) and follows it to the preliminary data point at plug No. 1. From there, the X-Y table moves to plug No. 1, position No. 47, and the second end is inserted. The table next moves to plug No. 1, position No. 48, where the first end of the second wire is inserted. Then subroutine A-to-B is used and plug No. 2, position No. 48, is positioned for insertion. The

THIS PAGE IS BEST QUALITY FRAGMENTS FROM COPY PROVIDED TO DDC

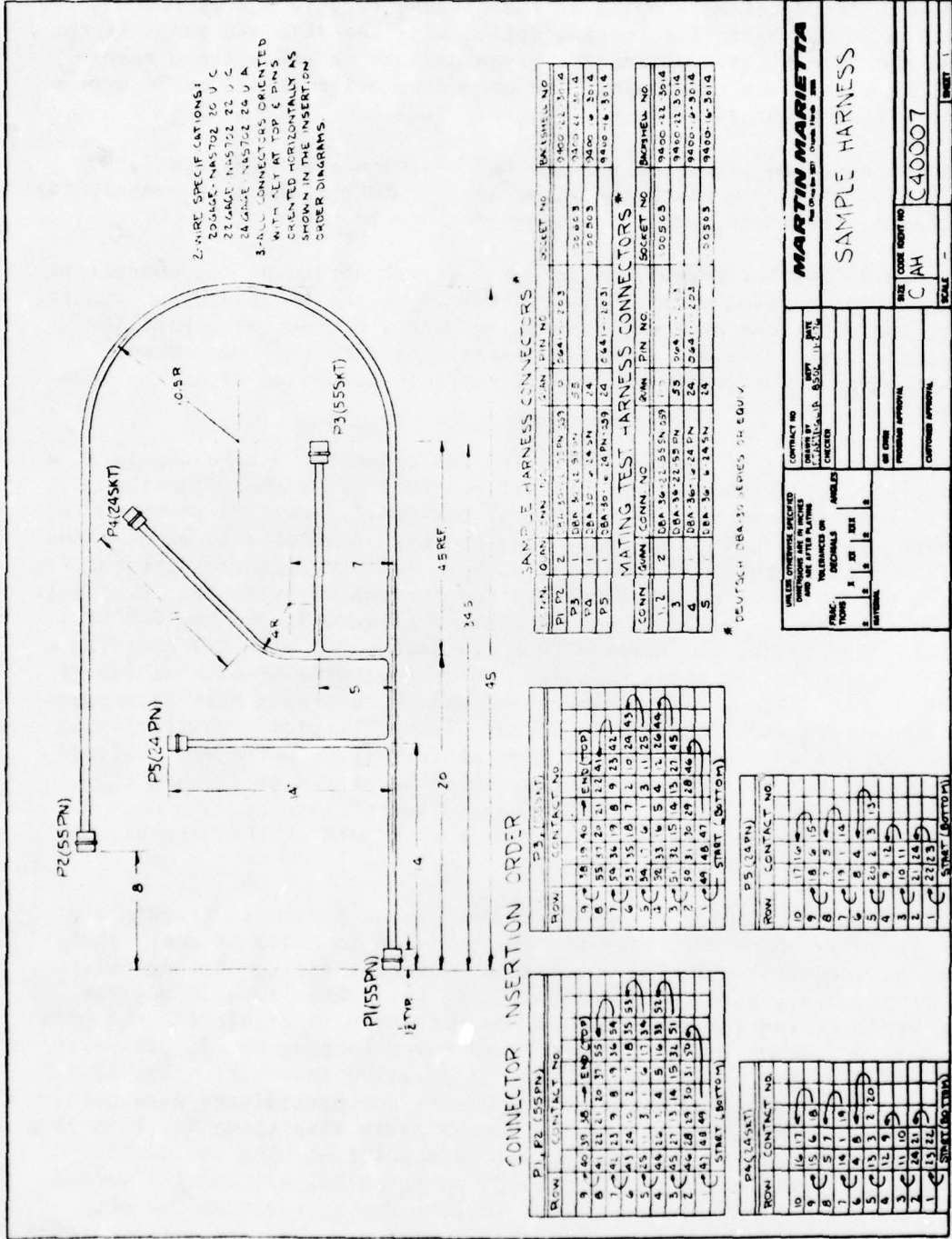

2-WIRE SPECIFICATIONS:
 20 GAUGE - MAX 702 20 U / C
 28 GAUGE - MAX 702 28 U / C
 3-WIRE CONNECTORS ORIENTED WITH KEY AT TOP & PINS SHOWN HORIZONTALLY AS SHOWN IN THE INSERTION ORDER DIAGRAMS

CONNECTOR INSERTION ORDER

CONN	WIRE	CONN. NO.	WIRE	CONN. NO.
1	1	1	1	1
1	2	2	2	2
1	3	3	3	3
1	4	4	4	4
1	5	5	5	5
1	6	6	6	6
1	7	7	7	7
1	8	8	8	8
1	9	9	9	9
1	10	10	10	10
1	11	11	11	11
1	12	12	12	12
1	13	13	13	13
1	14	14	14	14
1	15	15	15	15
1	16	16	16	16
1	17	17	17	17
1	18	18	18	18
1	19	19	19	19
1	20	20	20	20
1	21	21	21	21
1	22	22	22	22
1	23	23	23	23
1	24	24	24	24
1	25	25	25	25
1	26	26	26	26
1	27	27	27	27
1	28	28	28	28
1	29	29	29	29
1	30	30	30	30
1	31	31	31	31
1	32	32	32	32
1	33	33	33	33
1	34	34	34	34
1	35	35	35	35
1	36	36	36	36
1	37	37	37	37
1	38	38	38	38
1	39	39	39	39
1	40	40	40	40
1	41	41	41	41
1	42	42	42	42
1	43	43	43	43
1	44	44	44	44
1	45	45	45	45
1	46	46	46	46
1	47	47	47	47
1	48	48	48	48
1	49	49	49	49
1	50	50	50	50
1	51	51	51	51
1	52	52	52	52
1	53	53	53	53
1	54	54	54	54
1	55	55	55	55
1	56	56	56	56
1	57	57	57	57
1	58	58	58	58
1	59	59	59	59
1	60	60	60	60
1	61	61	61	61
1	62	62	62	62
1	63	63	63	63
1	64	64	64	64
1	65	65	65	65
1	66	66	66	66
1	67	67	67	67
1	68	68	68	68
1	69	69	69	69
1	70	70	70	70
1	71	71	71	71
1	72	72	72	72
1	73	73	73	73
1	74	74	74	74
1	75	75	75	75
1	76	76	76	76
1	77	77	77	77
1	78	78	78	78
1	79	79	79	79
1	80	80	80	80
1	81	81	81	81
1	82	82	82	82
1	83	83	83	83
1	84	84	84	84
1	85	85	85	85
1	86	86	86	86
1	87	87	87	87
1	88	88	88	88
1	89	89	89	89
1	90	90	90	90
1	91	91	91	91
1	92	92	92	92
1	93	93	93	93
1	94	94	94	94
1	95	95	95	95
1	96	96	96	96
1	97	97	97	97
1	98	98	98	98
1	99	99	99	99
1	100	100	100	100

CONN	WIRE	CONN. NO.	WIRE	CONN. NO.
1	1	1	1	1
1	2	2	2	2
1	3	3	3	3
1	4	4	4	4
1	5	5	5	5
1	6	6	6	6
1	7	7	7	7
1	8	8	8	8
1	9	9	9	9
1	10	10	10	10
1	11	11	11	11
1	12	12	12	12
1	13	13	13	13
1	14	14	14	14
1	15	15	15	15
1	16	16	16	16
1	17	17	17	17
1	18	18	18	18
1	19	19	19	19
1	20	20	20	20
1	21	21	21	21
1	22	22	22	22
1	23	23	23	23
1	24	24	24	24
1	25	25	25	25
1	26	26	26	26
1	27	27	27	27
1	28	28	28	28
1	29	29	29	29
1	30	30	30	30
1	31	31	31	31
1	32	32	32	32
1	33	33	33	33
1	34	34	34	34
1	35	35	35	35
1	36	36	36	36
1	37	37	37	37
1	38	38	38	38
1	39	39	39	39
1	40	40	40	40
1	41	41	41	41
1	42	42	42	42
1	43	43	43	43
1	44	44	44	44
1	45	45	45	45
1	46	46	46	46
1	47	47	47	47
1	48	48	48	48
1	49	49	49	49
1	50	50	50	50
1	51	51	51	51
1	52	52	52	52
1	53	53	53	53
1	54	54	54	54
1	55	55	55	55
1	56	56	56	56
1	57	57	57	57
1	58	58	58	58
1	59	59	59	59
1	60	60	60	60
1	61	61	61	61
1	62	62	62	62
1	63	63	63	63
1	64	64	64	64
1	65	65	65	65
1	66	66	66	66
1	67	67	67	67
1	68	68	68	68
1	69	69	69	69
1	70	70	70	70
1	71	71	71	71
1	72	72	72	72
1	73	73	73	73
1	74	74	74	74
1	75	75	75	75
1	76	76	76	76
1	77	77	77	77
1	78	78	78	78
1	79	79	79	79
1	80	80	80	80
1	81	81	81	81
1	82	82	82	82
1	83	83	83	83
1	84	84	84	84
1	85	85	85	85
1	86	86	86	86
1	87	87	87	87
1	88	88	88	88
1	89	89	89	89
1	90	90	90	90
1	91	91	91	91
1	92	92	92	92
1	93	93	93	93
1	94	94	94	94
1	95	95	95	95
1	96	96	96	96
1	97	97	97	97
1	98	98	98	98
1	99	99	99	99
1	100	100	100	100

CONN	WIRE	CONN. NO.	WIRE	CONN. NO.
1	1	1	1	1
1	2	2	2	2
1	3	3	3	3
1	4	4	4	4
1	5	5	5	5
1	6	6	6	6
1	7	7	7	7
1	8	8	8	8
1	9	9	9	9
1	10	10	10	10
1	11	11	11	11
1	12	12	12	12
1	13	13	13	13
1	14	14	14	14
1	15	15	15	15
1	16	16	16	16
1	17	17	17	17
1	18	18	18	18
1	19	19	19	19
1	20	20	20	20
1	21	21	21	21
1	22	22	22	22
1	23	23	23	23
1	24	24	24	24
1	25	25	25	25
1	26	26	26	26
1	27	27	27	27
1	28	28	28	28
1	29	29	29	29
1	30	30	30	30
1	31	31	31	31
1	32	32	32	32
1	33	33	33	33
1	34	34	34	34
1	35	35	35	35
1	36	36	36	36
1	37	37	37	37
1	38	38	38	38
1	39	39	39	39
1	40	40	40	40
1	41	41	41	41
1	42	42	42	42
1	43	43	43	43
1	44	44	44	44
1	45	45	45	45
1	46	46	46	46
1	47	47	47	47
1	48	48	48	48
1	49	49	49	49
1	50	50	50	50
1	51	51	51	51
1	52	52	52	52
1	53	53	53	53
1	54	54	54	54
1	55	55	55	55
1	56	56	56	56
1	57	57	57	57
1	58	58	58	58
1	59	59	59	59
1	60	60	60	60
1	61	61	61	61
1	62	62	62	62
1	63	63	63	63
1	64	64	64	64
1	65	65	65	65
1	66	66	66	66
1	67	67	67	67
1	68	68	68	68
1	69	69	69	69
1	70	70	70	70
1	71	71	71	71
1	72	72	72	72
1	73	73	73	73
1	74	74	74	74
1	75	75	75	75
1	76	76	76	76
1	77	77	77	77
1	78	78	78	78
1	79	79	79	79
1	80	80	80	80
1	81	81	81	81
1	82	82	82	82
1	83	83	83	83
1	84	84	84	84
1	85	85	85	85

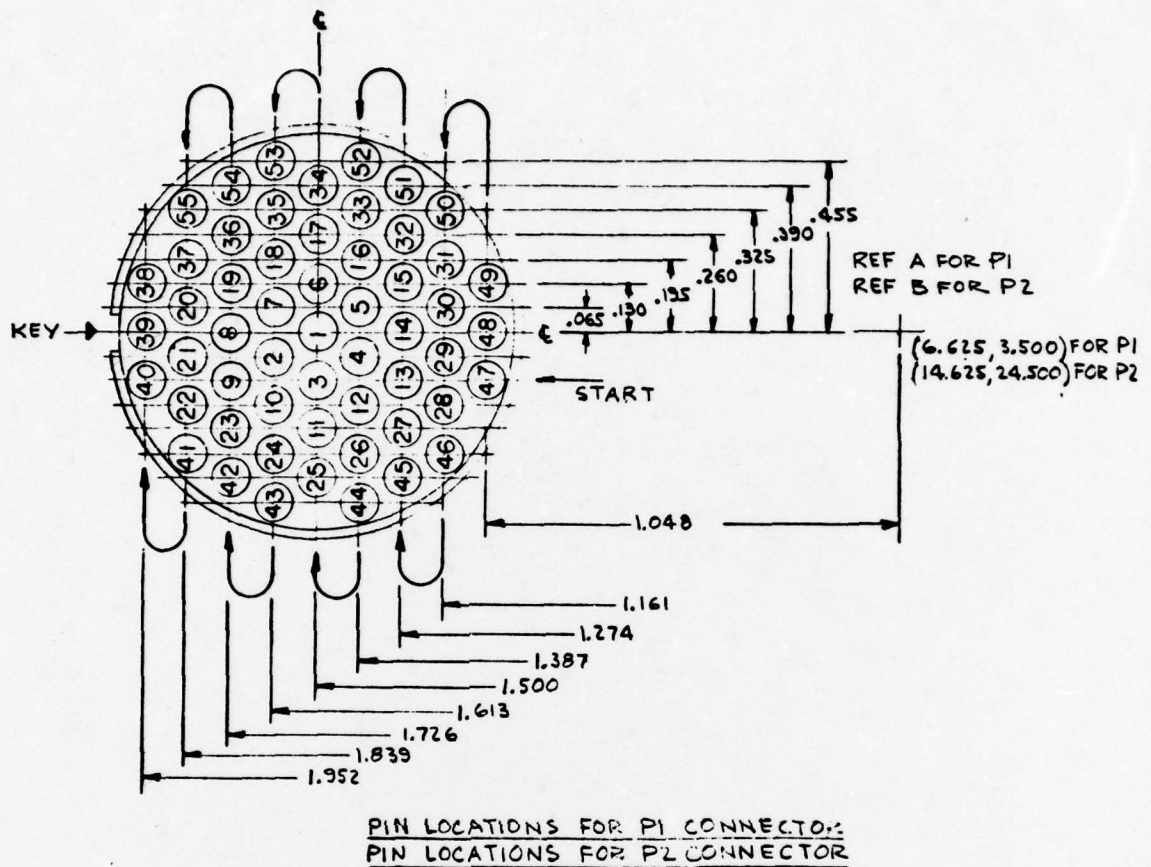

Figure 8. Connector Data Sheet

pattern is completely developed in this manner using productive (wire laying) runs wherever possible. The program finally developed for this harness required only five nonproductive (empty) runs (Figure 11).

2.2 Manual Wire Preparation Facility

The manual wire preparation facility prepares wires that are not run through the automatic equipment. This equipment has a variety of hand tools to cut, strip, mark, and terminate a large range of wire types and configurations manually. Although the mechanized harness preparation facility is based on a process with minimum manual interface, provision must be made for necessary manual interface functions that occur when there is:

- 1 A machine malfunction. The malfunction is corrected, and the wire that is then in process is either used or, if unusable, is removed. The wire is then replaced with one that is manually prepared.
- 2 A requirement for a wire (or wires) not compatible with the mechanized system that cannot be run through the automatic equipment. These components may be twisted pairs or shielded wires which would be fabricated manually and installed after the mechanized operation is complete.

X-Y TABLE PROGRAMMING DATA

WIRE NO.	CONNECTOR AND CONTACT CONNECTIONS				X-Y LOCATION OF TABLE TRAVEL						DEADHEAD TRAVEL OF X-Y TABLE		
	P1	P2	P3	P4	P5	INSERTION		SUBROUTINE PATH	INSERTION				
						CONTACT	X		Y	CONTACT		X	Y
1	47	47				P2-47	13.577	24.370	B to A	P1-47	5.577	3.370	START (O,O)
2	48	48				P1-48	5.577	3.500	A to B	P2-48	13.577	24.500	
3	49	49				P2-49	13.577	24.630	B to A	P1-49	5.577	3.630	
4	50	50				P1-50	5.464	3.825	A to B	P2-50	13.464	24.825	
5	31	31				P2-31	13.464	24.585	B to A	P1-31	5.464	3.695	
6	30	30				P1-30	5.464	3.565	A to B	P2-30	13.464	24.565	
7	29	29				P2-29	13.464	24.435	B to A	P1-29	5.464	3.435	
8	28	28				P1-28	5.464	3.405	A to B	P2-28	13.464	24.405	
9	46	46				P2-46	13.464	24.175	B to A	P1-46	5.464	3.175	
10	45	45				P1-45	5.351	3.110	A to B	P2-45	13.351	24.110	
11	27	27				P1-27	13.351	24.240	B to A	P2-27	5.351	3.240	
12	13	13				P1-13	5.351	3.370	A to B	P2-13	13.351	24.370	
13	14	14				P2-14	13.351	24.500	B to A	P1-14	5.351	3.500	
14	15	15				P1-15	5.351	3.630	A to B	P2-15	13.351	24.630	
15	32	32				P2-32	13.351	24.760	B to A	P1-32	5.351	3.760	
16	51	51				P1-51	5.351	3.890	A to B	P2-51	13.351	24.890	
17	52	52				P2-52	13.238	24.555	B to A	P1-52	5.238	3.955	
18	33	33				P1-33	5.238	3.825	A to B	P2-33	13.238	24.825	
19	16	16				P2-16	13.238	24.695	B to A	P1-16	5.238	3.695	
20	5	5				P1-5	5.238	3.565	A to B	P2-5	13.238	24.565	
21	4	4				P2-4	13.238	24.435	B to A	P1-4	5.238	3.435	
22	12	12				P1-12	5.238	3.405	A to B	P2-12	13.238	24.405	
23	26	26			22	P2-26	13.238	24.175	B to A	P1-26	5.238	3.175	
24	44	44			23	P1-23	16.065	14.078	A to B	P2-44	13.238	24.045	
25	43	43			24	P2-23	13.238	24.110	B to A	P1-43	5.238	3.110	
26	11	11			21	P1-11	15.823	14.143	A to B	P2-11	13.238	24.143	
27	3	3			10	P2-3	13.128	24.370	B to A	P1-10	15.823	14.208	
28	1	1			11	P1-1	16.065	14.208	A to B	P2-1	13.128	24.500	P2-1 TO P4-23 BY SUBROUTINE B TO D
29			43	23		P4-23	28.484	18.733	D to C	P3-49	32.923	8.630	
30			46	23		P3-49	32.923	8.500	C to D	P4-22	28.576	18.640	
31			47	21		P4-21	28.700	18.601	D to C	P3-47	32.923	8.370	
32			46	24		P3-46	33.036	8.175	C to D	P4-24	28.451	18.658	
33			48	11		P4-11	28.576	18.825	D to C	P3-11	33.036	8.395	
34			29	10		P3-29	33.036	8.435	C to D	P4-10	28.648	18.733	P4-10 TO P2-6 BY SUBROUTINE D TO B
35			6	5		P2-6	13.125	24.630	B to D	P4-9	28.793	18.699	
36	17	12				P4-12	28.542	18.950	D to B	P2-17	13.125	24.760	
37	34	13				P2-34	13.125	24.890	B to D	P4-13	28.523	19.060	
38	33	3				P4-3	28.668	18.917	D to B	P2-33	13.012	24.955	
39	35	2				P2-35	13.972	24.925	R to D	P4-2	28.760	19.025	
40	18	20				P4-20	28.905	18.840	D to B	P2-18	13.012	24.995	
41		30				P2-7	13.012	24.565	B to C	P3-30	33.036	8.565	
42	2	31				P3-31	33.036	8.495	C to B	P2-2	13.012	24.435	
43	10	50				P2-10	13.012	24.405	B to C	P3-50	33.036	8.925	
44	24	51				P1-51	33.149	8.890	A to B	P2-24	13.012	24.175	
45	43	32				P2-43	13.012	24.245	B to C	P3-32	33.149	8.760	
46	42	15				P3-15	33.149	8.830	C to B	P2-42	12.899	24.10	
47	23	14				P1-23	12.899	24.240	A to B	P3-14	33.149	8.500	
48	9	13				P3-13	33.149	8.370	C to B	P2-9	12.899	24.370	
49	8	27				P2-8	12.899	24.500	B to C	P3-27	33.149	8.240	
50	19	45				P3-45	33.149	8.110	C to B	P1-19	12.899	24.640	
51	36	44				P2-36	12.899	24.760	B to C	P3-44	33.262	8.045	
52	54	26				P3-26	33.262	8.175	C to B	P2-54	12.899	24.890	
53	55	12				P2-55	12.786	24.825	B to C	P3-12	33.262	8.305	
54	37	4				P1-4	33.262	8.435	A to B	P2-37	12.786	24.495	
55	20	5				P2-20	12.786	24.565	B to C	P3-5	33.262	8.565	
56	21	16				P3-16	33.262	8.695	C to B	P2-21	12.786	24.435	
57	22	33				P2-22	12.786	24.405	B to C	P3-33	33.262	8.825	
58	41	52				P3-52	33.262	8.955	C to B	P2-41	12.786	24.175	
59	40	34				P2-40	12.613	24.370	B to C	P3-34	33.375	8.890	
60	33	17				P1-17	33.375	8.760	A to B	P2-33	12.613	24.500	
61	36	6				P2-36	12.613	24.630	B to C	P1-6	33.375	8.630	
62	26	11				P1-11	33.375	8.500	A to B	P2-26	12.613	24.370	
63	44	3				P1-44	5.238	3.045	A to C	P3-3	33.375	8.370	
64	25	11				P3-11	33.375	8.240	C to A	P1-25	5.125	3.110	
65	11	25				P1-11	5.125	3.240	A to C	P3-25	33.375	8.110	
66	3	43				P3-43	33.488	8.045	C to A	P1-3	5.125	3.370	
67	1	24				P1-1	5.125	3.500	A to C	P3-24	33.488	8.175	
68	6	10				P3-10	33.488	8.305	C to A	P1-6	5.125	3.630	
69	17	2				P1-17	5.125	3.760	A to C	P3-2	33.488	8.435	
70	34	7				P3-7	33.488	8.565	C to A	P1-34	5.125	3.690	
71	53	18				P1-53	5.012	3.955	A to C	P3-18	33.488	8.695	
72	35	35				P3-35	33.488	8.825	C to A	P1-35	5.012	3.825	
73	18	53				P1-18	5.012	3.695	A to C	P3-53	33.488	8.955	
74	7	54				P3-54	33.601	8.890	C to A	P1-7	5.012	3.565	
75	7	36				P1-7	5.012	3.435	A to C	P3-36	33.601	8.160	
76	10	19				P3-19	33.601	8.630	C to A	P1-10	5.012	3.405	
77	24	8				P1-24	5.012	3.175	A to C	P3-8	33.601	8.500	
78	43	9				P3-9	33.601	8.370	C to A	P1-43	5.012	3.045	
79	42	23				P1-42	4.899	3.110	A to C	P3-23	33.601	8.240	
80	23	42				P3-42	33.601	8.110	C to A	P1-23	4.899	3.240	
81	9	41				P1-9	4.899	3.370	A to C	P3-41	33.714	8.175	
82	8	22				P3-22	33.714	8.305	C to A	P1-8	4.899	3.500	P1-8 TO P1-12 BY SUBROUTINE A TO E
83		21			2	P2-21	16.177	14.273	E to C	P3-21	33.714	8.435	
84		20			9	P3-20	33.714	8.865	C to E	P1-9	16.177	14.273	
85		37			20	P5-20	15.731	14.338	E to C	P3-37	33.714	8.695	
86		55			2	P3-55	33.714	8.825	C to E	P5-2	15.935	14.338	
87		38			3	P5-3	16.065	14.338	E to C	P3-38	33.827	8.630	
88		39			13	P3-39	33.827	8.500	C to E	P5-13	16.269	14.338	P4-3 TO P4-6 BY SUBROUTINE E TO D
89					4	P4-4	28.684	18.791	D to A	P1-19	4.899	3.430	
90					1	P1-36	4.899	3.760	A to D	P4-4	28.634	19.041	
91	54	14				P4-14	28.415	19.152	D to A	P1-54	4.899	3.890	
92	55	1				P1-55	4.786	3.625	A to D	P4-1	28.793	18.950	
93	37	19				P4-19	28.595	18.772	D to A	P1-37	4.786	3.695	
94	20	19				P1-20	4.786	3.565	A to D	P4-7	28.513	18.917	
95		15			4	P6-5	28.759	19.074	D to E	P5-4	16.177	14.403	
96		15			8	P5-8	15.873	14.403	E to D	P4-15	28.721	18.700	
97		6			19	P4-6	28.584	19.041	D to E	P5-19	15.731	14.468	
98		18			1	P5-1	16.000	14.450	E to D	P4-18	29.043	18.883	
99		17			14	P4-17	28.009	19.008	D to E	P5-14	16.269	14.468	
100		16			5	P5-5	16.112	14.515	E to D	P4-16	28.851	19.166	P4-6 TO P5-7 BY SUBROUTINE D TO E
101	21				7	P5-7	15.888	14.515	E to A	P1-21	4.786	3.435	
102	22				18	P1-22	4.786	3.405	A to E	P5-18	15.776	14.579	
103	41				6	P5-6	16.000	14.579	E to A	P1-41	4.786	3.175	
104	40				15	P1-40	4.673	3.370	A to E	P5-15	16.224	14.579	
105	39				16	P5-16	16.112	14.644	E to A	P1-39	4.673	3.500	
106	38				17	P1-38	4.673	3.630	A to E	P5-17	15.888	14.644	RETURN (O,O)

NOTE
* CONTACT F3-40 IS BLANK

Figure 11. X-Y Table Programming Data
(Dwg. No. F40009)

THIS PAGE IS BEST QUALITY PRINTED
FROM COPY FURNISHED TO DDC

The manual station has a thermal stripper altered to accept and strip insulation from a twisted pair of wires, and a flash stripper altered to remove shielding from single wires and twisted pairs.

The manual wire preparation facility prepared for this contract is shown in Figure 12. It stores the reels of wire, connectors, terminals, a twisted wire thermal stripper, a flash stripper for shielded wire, and the miscellaneous hand tools for preparing the necessary wires. It thus follows conventional practice.

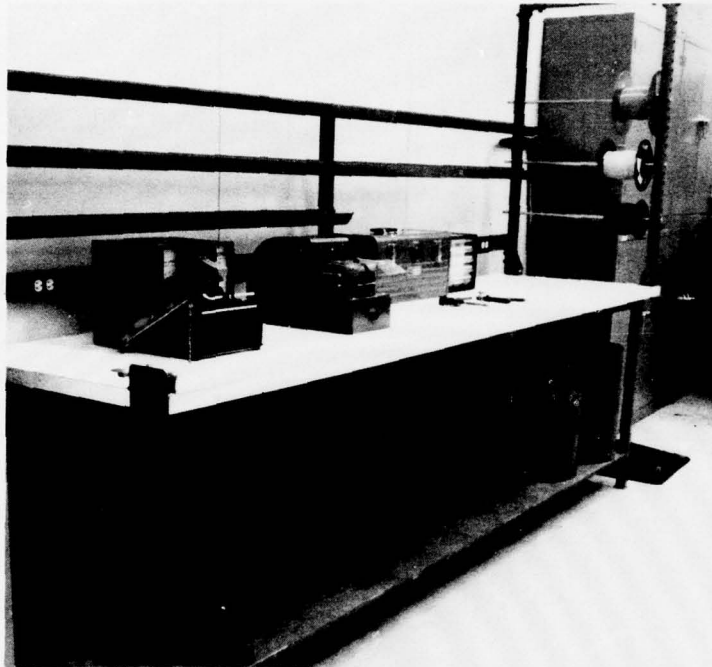

Figure 12. Manual Wire Preparation Facility

2.3 Harness Tooling Board (Dwg No. F40000)

The tooling board designed for this mechanization program is more complex than the tooling boards currently in use in the industry (Figure 13). The board is a two-level design consisting of a heavy aluminum lower level that supports the holding fixtures for the connectors and the upper level. The edges are accurately machined to provide the 0,0 coordinate location at the lower left corner, when positioned against the stop blocks mounted on the X-Y table.

The upper level board is less sophisticated, consisting of a wooden platform that holds guides and latches mounted in the desired harness configuration to capture and restrain the wires during laying. The guides have generous openings to accept and restrain the wires. Figure 14 (Dwg No. C40010) shows the types of guides and latches that were developed and tested on the tooling board. The guide selected as most reliable (large orifice and a single spring latch) is shown in the foreground.

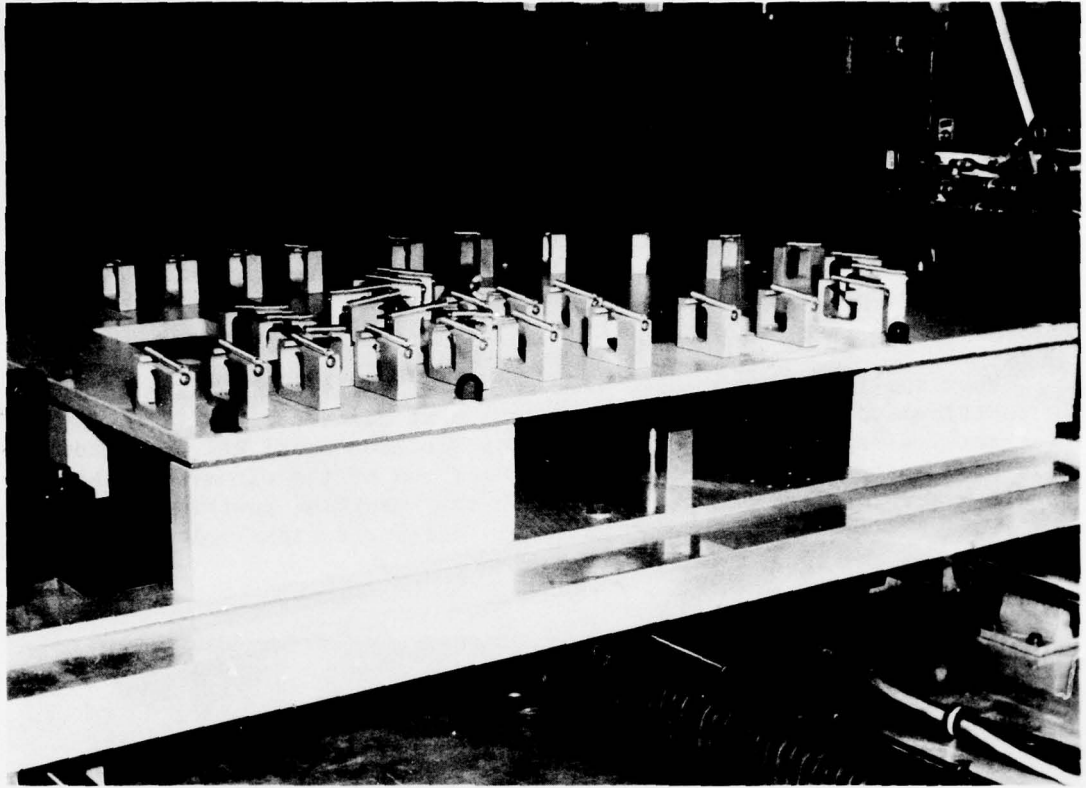

Figure 13. Tooling Board

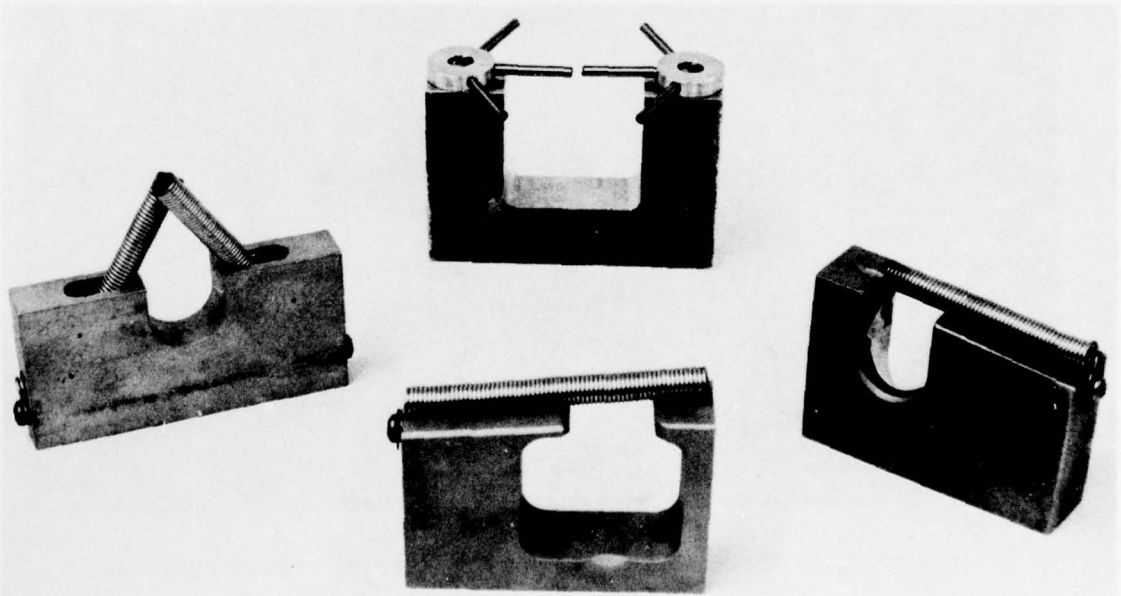

Figure 14. Tooling Board Latch and Guide Elements

The connector holding fixture was designed to position the connector vertically during the assembly process and then swing into a horizontal position in the plane of the harness, to allow dressing of the wires and tying (Figures 15 and 16, Dwg No. F40100). The connector holding fixtures are secured on the tooling board with tooling clamps, to eliminate the extremely accurate positioning relationships that would be required if the fixtures were permanently bolted to the tooling base. With this clamping method, the positioning program is prepared and the table is moved to the center position of the connector. An alignment adapter is placed on the insertion head, and the head is lowered over the connector. The fixture is thus centered under the head and oriented radially to match the insertion pattern of the program.

When the locking procedure is complete, the fixture is clamped firmly in position and the table is moved to the next connector position. This procedure is repeated with each connector position until all connectors have been positioned properly for the insertion of the wires. In this way, complete accuracy and compatibility with the insertion positioning program are achieved, without requiring extremely difficult close tolerance positioning over the length of the X-Y table.

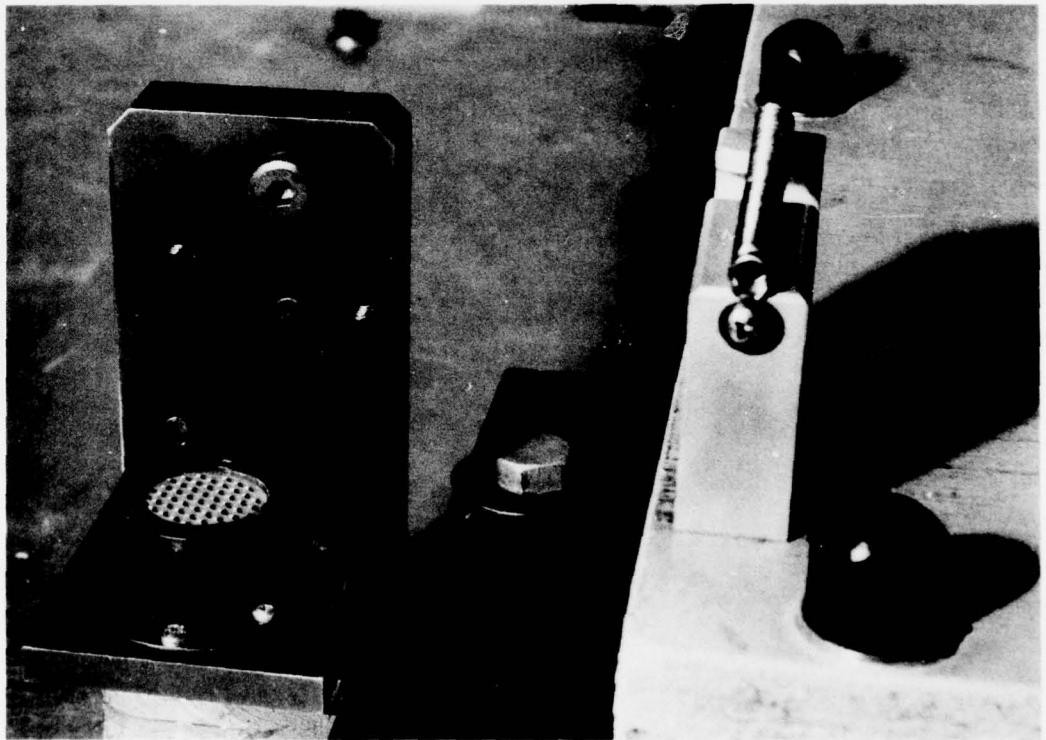

Figure 15. Tooling Board Connector Fixture - Down Position
(Dwg. No. F40100)

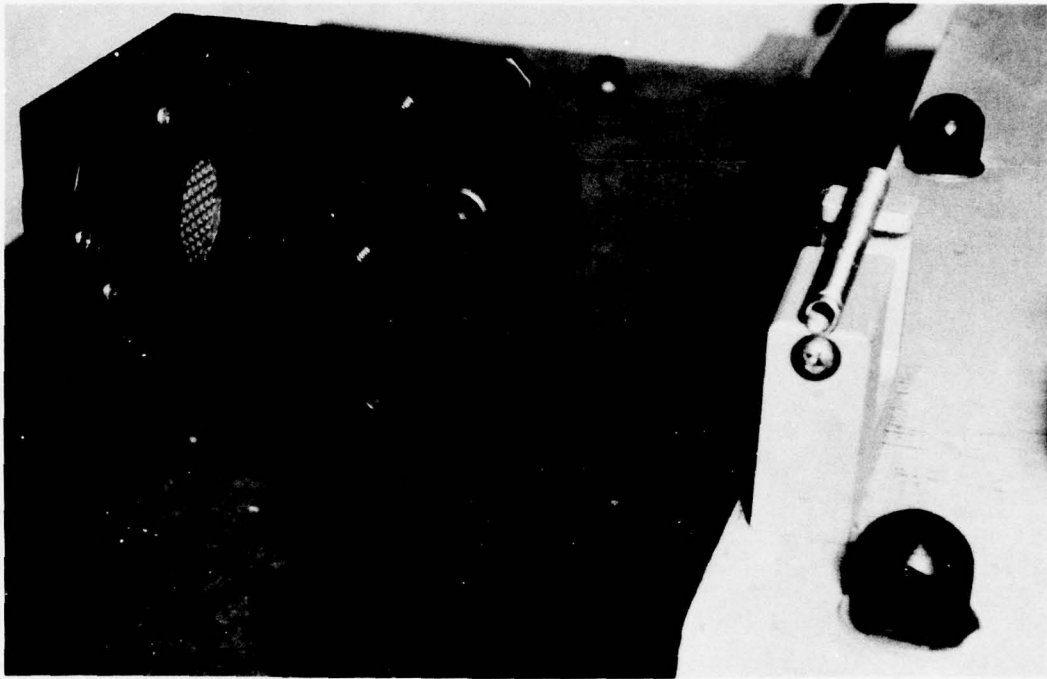

Figure 16. Tooling Board Connector Fixture - Up Position

2.4 Terminated Wire Reeler (Dwg No. F1000)

The first of the three major machines designed and fabricated was the terminated wire reeler. In the original system concept, this machine was set up to take single gage wires after they had been prepared and terminated, and to wind them in a primary sequence on a reel between the two layers of a Velcro zipper tape (Figure 17). The machine consists of:

- 1 A drive unit with a shaft extension to fit the standard reel
- 2 An entry mechanism with a control microswitch and tape rollers
- 3 Two tape tension mechanisms
- 4 A control system for either manual or automatic operation, and with an adjustable time delay to adjust wire spacing.

To operate the machine, the two parts of the Velcro zipper tape are threaded through the tension mechanisms, around the inlet rollers, and onto the reel. Presized terminated wires of one gage are prepared and brought to the machine in the proper sequence. The wires are manually passed into the entry funnel, where a microswitch is tripped (Figure 18). This switch activates the reel drive and causes the Velcro zipper tape to close around the wire and draw it onto the reel. As the trailing end of the wire passes

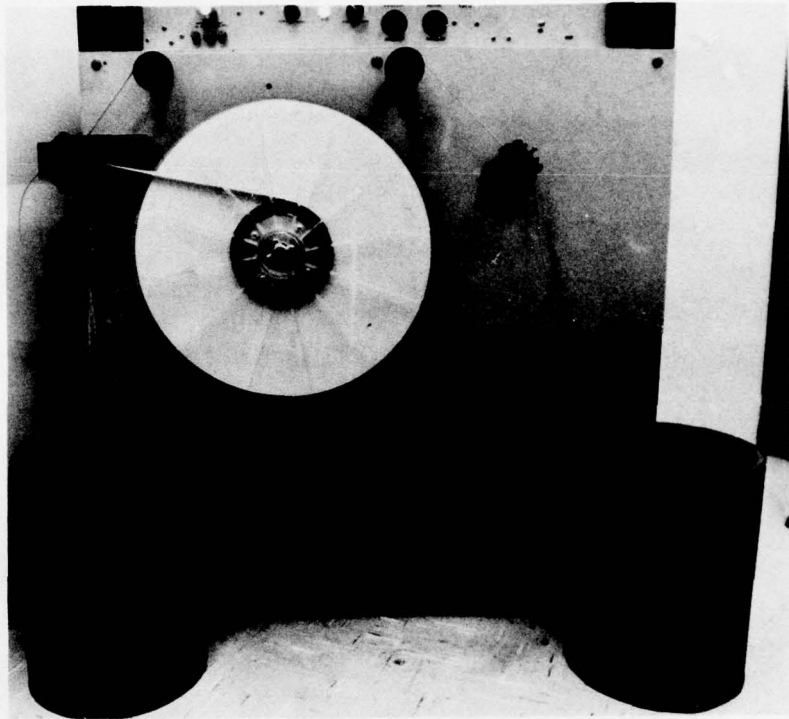

Figure 17. Terminated Wire Reeler



Figure 18. Terminated Wire Reeler - Entry Mechanism

the microswitch, a time delay relay controls the reel stopping time and, therefore, the spacing between wires.

After the last wire is run onto the reel, the control switch is moved from automatic to manual, the run button is pressed, and the balance of the tape is wound onto the reel. Each of the three different wire gages used on this prototype was wound separately on reels in their primary sequences. The windup speed of the reel varies from 5.3 in/s at the center to 21.4 in/s at the outside when the reel is full.

The Velcro zipper tape is stored loose in drums rather than on reels for ease of handling and to eliminate the inertia problem that would be caused by the mass of the tape and the holder if it were stored on the reel.

2.5 Reel-to-Reel Sequencer

The second major machine is the reel-to-reel sequencer. This machine was designed to take the three sets of wires of different gages and to coordinate these wires into a final reel, with the total harness sequence ready for assembly as shown in Figure 19 (Dwg No. F30000).

This machine consists of:

- 1 Three upper wire dispensing units with capstan stepping motor speed control drives and torque motor tensioning devices.
- 2 One transfer and pickup mechanism (Figure 20).
- 3 One wire reeling unit with torque motor drive and capstan stepping motor speed control drive.
- 4 Control system to cycle through the repetitive motions and a tie-in to the control microprocessor for the procedures requiring decision control.
- 5 Velcro tape dispensing and collecting systems for handling of the four sets of carrier tape.

To operate the machine, the three reels of wire to be intermixed are loaded with the No. 20 gage wire on reel position No. 1, the No. 22 gage wire on reel position No. 2 and the No. 24 gage wire on reel position No. 3. Each set of carrier tapes is threaded through the dispensing rolls, over the idler rollers, through the torque motor take up rollers, and into the storage drums. The receiving roll is positioned and tapes are threaded through the tension devices and the tape capstan. The ends are passed onto the reel and fastened to the flange through the center access hole. The system is now turned on, and the reel-to-reel program is initiated on the microprocessor. Following the program instructions, typing in the desired wire sequence causes the transfer of the wires from the primary upper reels

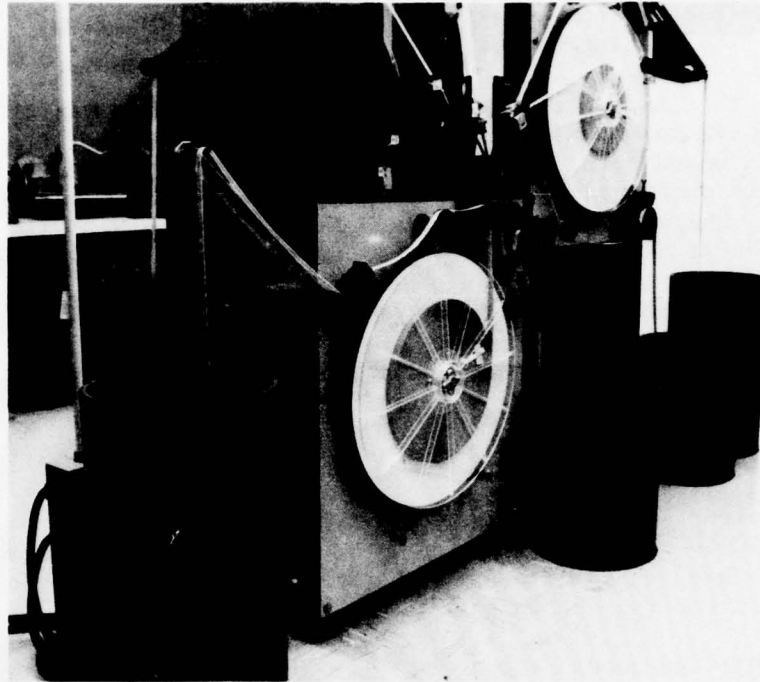

Figure 19. Reel-to-Reel Sequencer

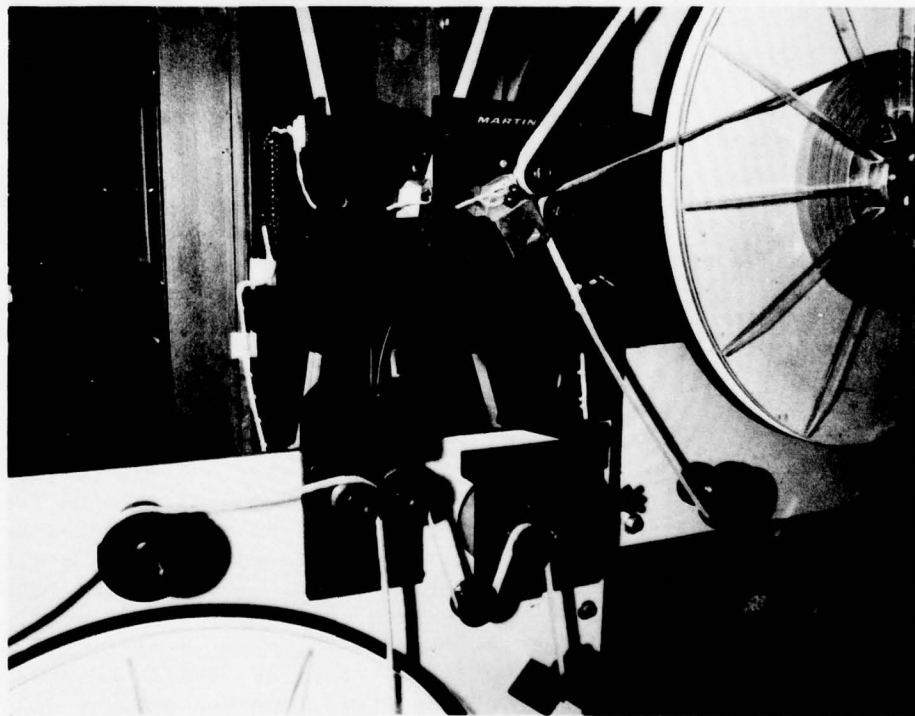

Figure 20. Reel-to-Reel Sequencer - Transfer Mechanism

to the lower final reel in the sequence that will be used in the final harness assembly.

The maximum linear tape speed that worked efficiently was 9 inches per second, and all units (including the X-Y table) were coordinated to that speed so the feeds and take-ups would perform without excess tension or slack in the system.

2.6 Harness Assembly Machine

The third major component built was the harness assembly machine (Figure 21). In this machine the wires, already loaded on the final reel and arranged in the desired harness sequence are assembled into the harness configuration and terminated into their specified connectors. This machine consists of the following subsystems:

- 1 A Wesel X-Y table with a 24 by 48 inch working area and an accuracy of .001 inch per foot of travel or a total of .005 inch over the whole table travel. (Refer to Bill of Material, Appendix F, for full specifications).
- 2 A dispensing and inserting mechanism (Dwg No. F20000).
- 3 A cross truss to carry the assembly equipment.
- 4 An X-Y drive system with circular interpolation and an accurate travel speed control.
- 5 A wire dispensing drive system with torque motor slack and tension control, and a capstan-stepping motor drive to provide accurate feed and speed control.
- 6 A tooling board with suitable fixtures to hold specified connectors, and spring latches and wire guides to maintain the harness configuration during assembly (Dwg No. F40000).
- 7 A control console designed to provide manual operation of the various machine functions and with circuitry to control the repetitive cycle operations.
- 8 A microprocessor that supplies the nonrepetitive intelligence decisions required to assemble the sample harness.

During development and checkout of the equipment, initial process runs were made at 5 in/s, the upper speed limit in the industry for X-Y tables of this type and size. Since the harness requires only light loading on the tables, higher table speeds were tried. The present operating speed has been established at 9 in/s, at which the process runs easily and reliably.

The operation of the machine through a typical assembly procedure starts with the loading of the connectors onto the tooling board fixtures.

If necessary, a program can be called up to position the table with the connectors under the head to verify the accuracy of the connector positions.

The harness reel is loaded on the machine, and the tapes are threaded through the dispenser and led into the storage drums. The program is then initiated in the microprocessor. The X-Y table is zeroed manually, and the program is started by pressing the advance button on the control console.

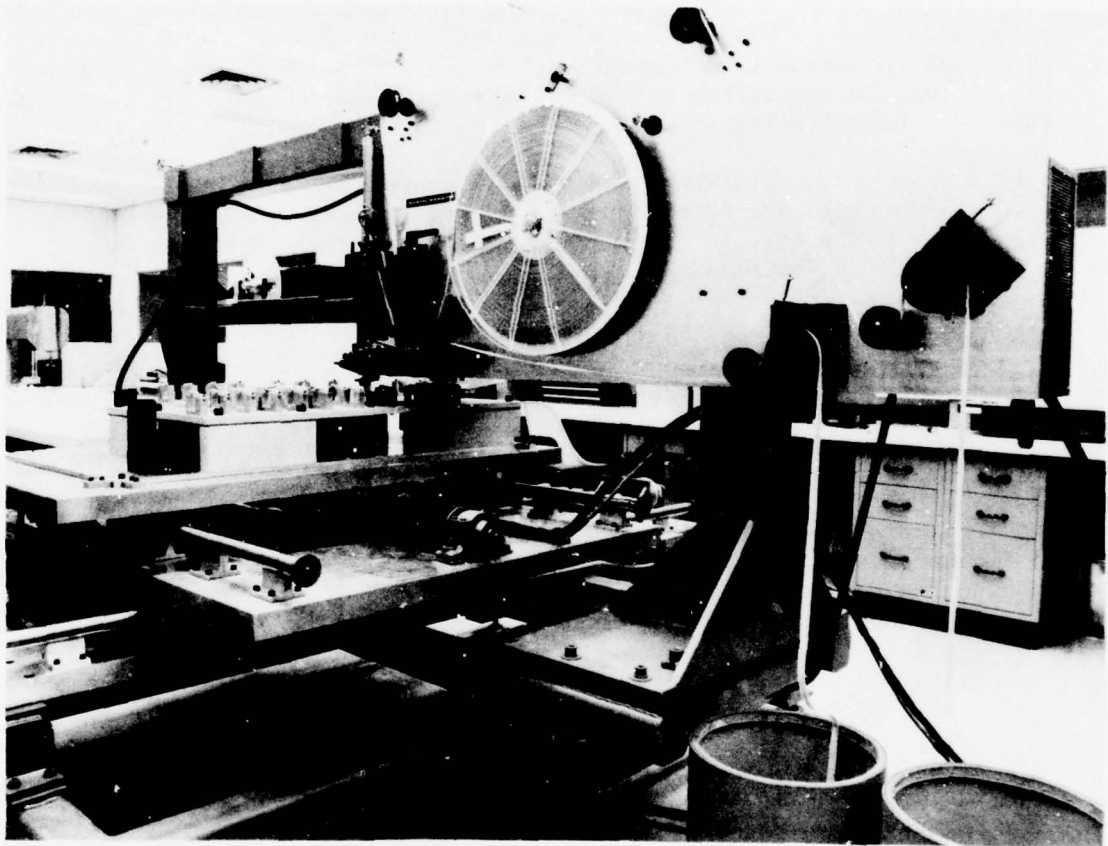

Figure 21. Harness Assembly Machine

The X-Y table moves on the first insertion position (P2, pin 47, as described on the programming data sheet, Figure 10) and waits for the first wire. At the same time, the dispensing mechanism starts unwinding the reel. The leading end of the first wire emerges, passes through the main mechanism and activates a microswitch (Figure 22). This signals the control system of the stepping motor drive to move the wire 5-3/4 inches further, and stops the drive system with the wire end in the proper position for insertion (Figure 23). The wire is clamped firmly in position, and the insertion head moves down to pick up the wire in its access slot and positions it for insertion (Figure 24).

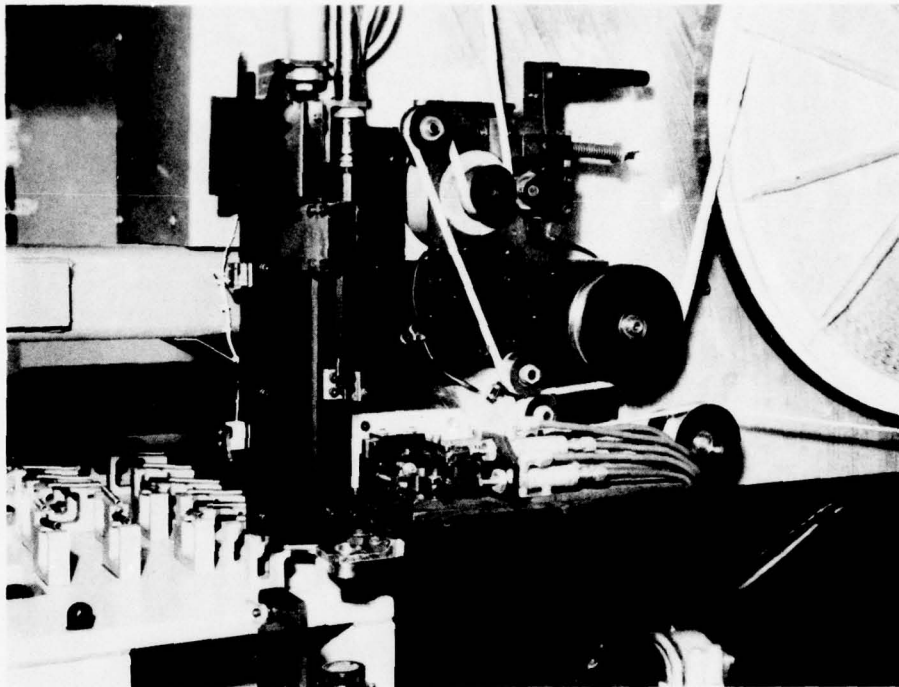

Figure 22. Dispensing and Insertion Unit

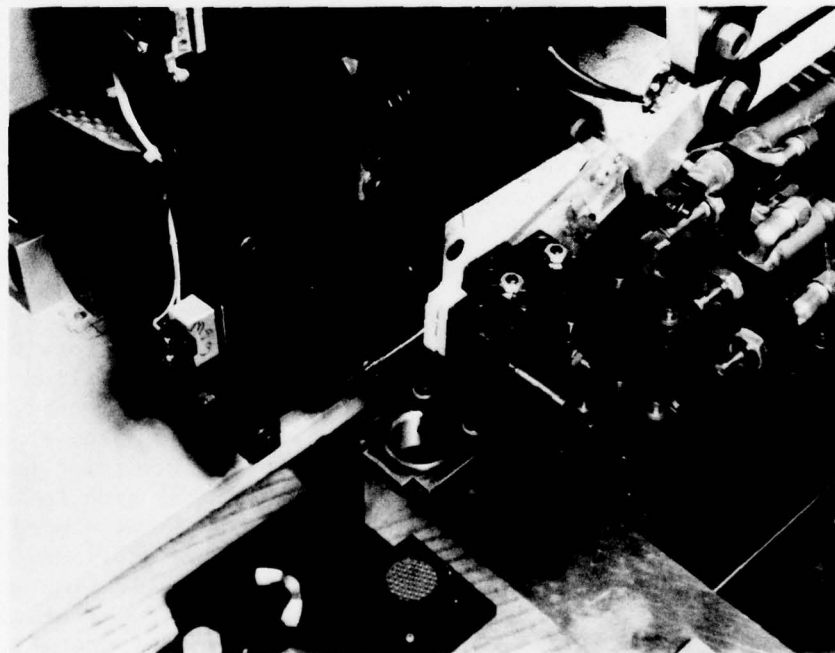

Figure 23. Insertion Head - Quill in Pickup Position
(Front View)

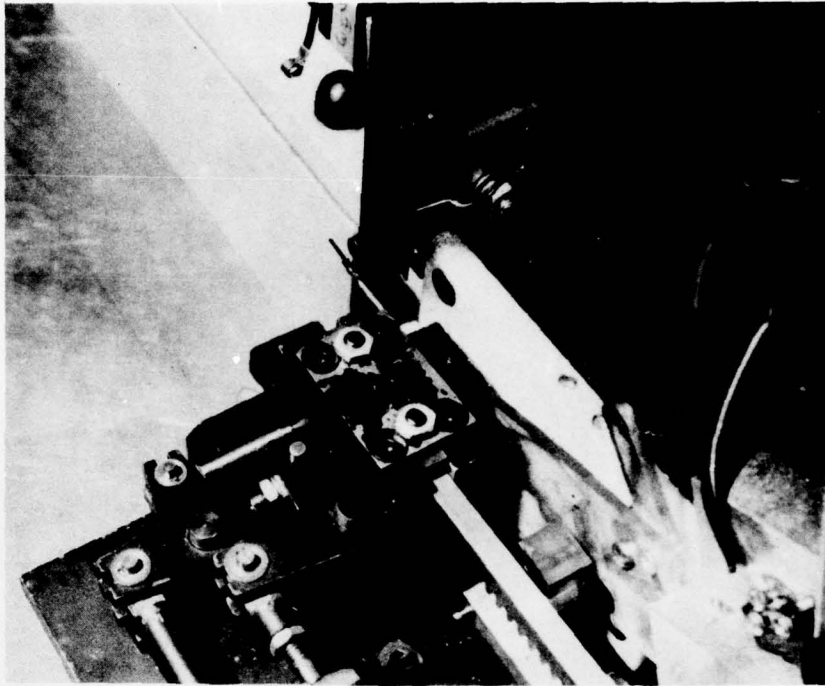

Figure 24. Insertion Head - Quill in Pickup Position
(Back View)

After the wire is picked up by the insertion head, it is moved downward through the wire-laying thimble and inserted into the connector cavity positioned below. A secondary quill then seats the terminal (Figure 25). During this downward stroke, while the wire is still held in the clamp, a pull test is made by the action of the head, and thus crimp integrity is verified. The head is retracted so that the wire extends upward through the thimble and back onto the reel. Next, the X-Y table moves through a specified harness path, as shown in Figure 9 (Dwg No. F40009). The thimble moves the spring latches aside and the wire is laid in the guides as the reel unwinds the balance of the wire.

When the trailing end of the wire passes under the microswitch, a signal is given to a reversing mechanism that revolves the trailing end of the wire so it is presented to the insertion head in the same manner as the leading end was positioned (Figure 26). The wire is clamped, the reversing mechanism retracted, and the head moves down for the insertion procedure. By this time, the X-Y table has followed its programmed path to the second connector position, and when the table stops in position the head is allowed to complete the second insertion. This action continues until all wires have been processed onto the tooling board, at which time the X-Y table returns to its home (0,0) position. If there is a malfunction and the stop button is pressed, the wire must be repaired and manually inserted or removed for later installation, since the program will continue with the next wire in the sequence.

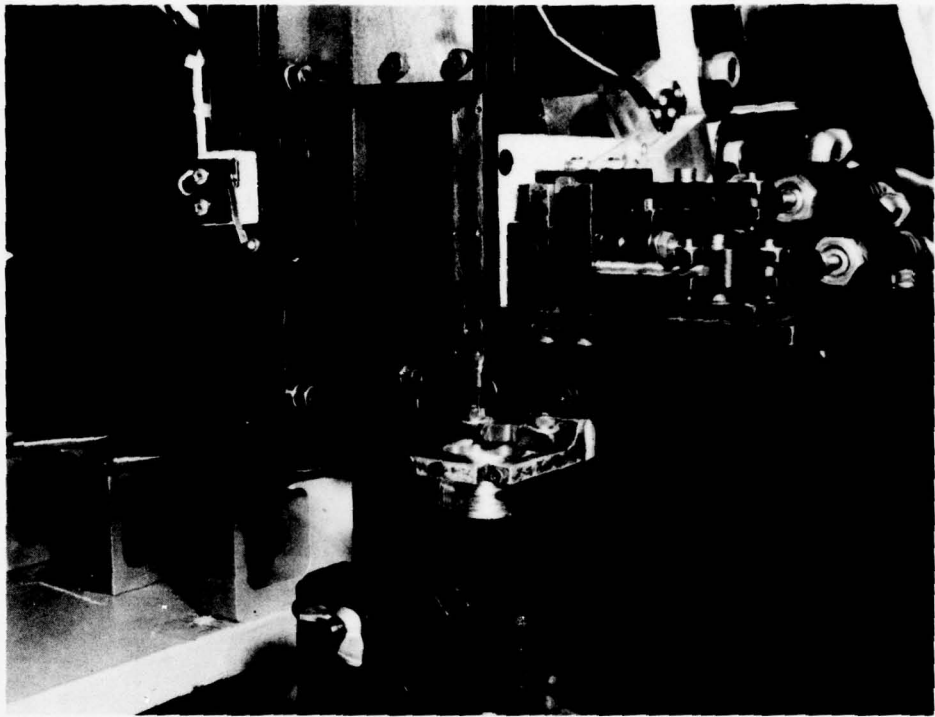

Figure 25. Insertion Head - Pickup Complete

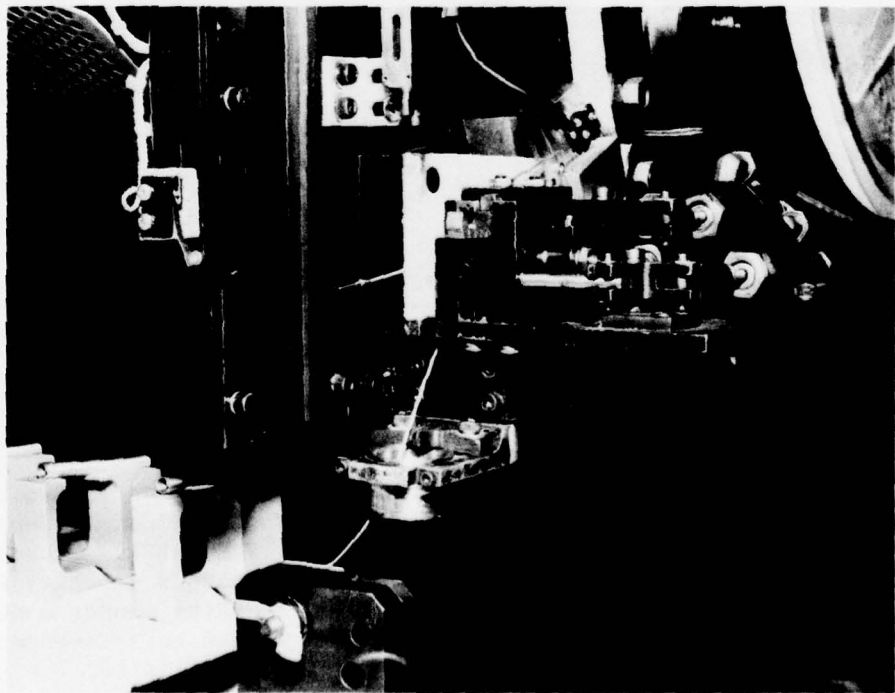

Figure 26. Insertion Head - Reversing Mechanism

2.6.1 Control System

The control console (Figure 27) was custom designed and built to provide manual manipulations of the various systems as required, to check out functions during run-in testing. This console was programmed to fabricate only the sample demonstration harness and was designed with read-only memory units. Thus, in its present form, it cannot process other harness configurations.



Figure 27. Control Console

The movement of the X-Y table and the necessity for coordination of the complex related motions require continuous input of instructions from the control system. The heart of this control is a DEC-PDP11 Microprocessor with 24K memory (Figure 28). This unit has excess capacity and extreme flexibility, and has performed in an outstanding manner under all operating conditions. It can easily handle all of the requirements of the harness assembly machine and also make the reel selections for the reel-to-reel sequencer.

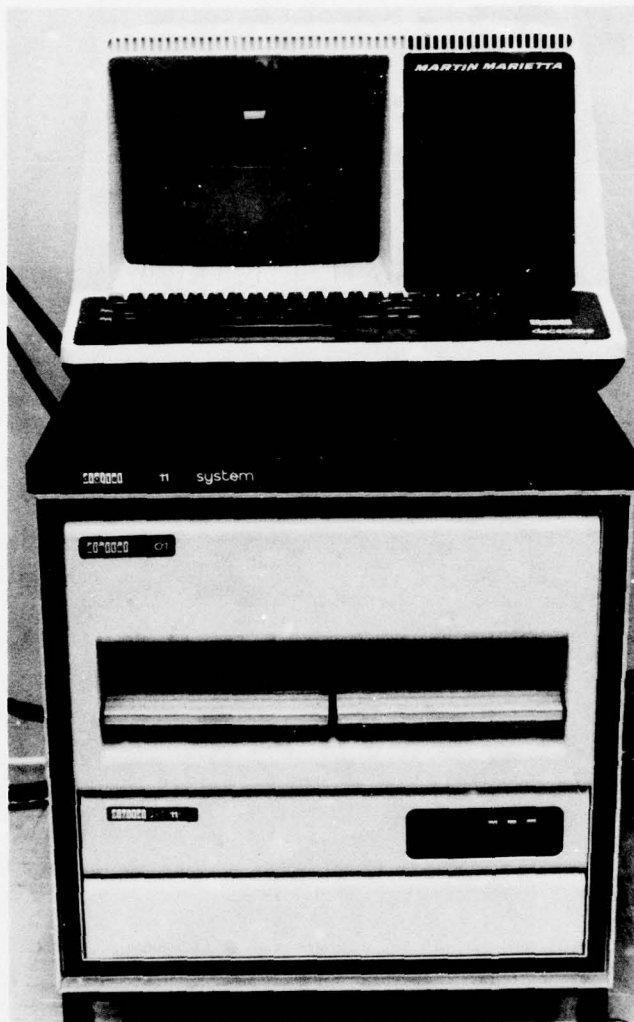

Figure 28. System
Microprocessor

2.7 Harness Tying

The procedure for tying the harness was studied in both the manual and the automatic modes to determine the most feasible and economical method to incorporate it into the facility. Two basic approaches were studied: the manual application of plastic ties with a semiautomatic handheld tool, and a totally mechanized method. Both methods used a Panduit PADIM Dispenser in which the ties are supplied pneumatically from a cartridge to a tying head. When the head is triggered, the tie is automatically applied, tightened, and trimmed.

In the manual approach, the operator approaches the tooling board after all assembly work is completed, and manually applies ties, starting from the connectors in all cases and working back along each run. The

tying head is easily positioned and oriented for each succeeding tie as the operator dresses the wires and proceeds around the harness configuration (Figure 29).

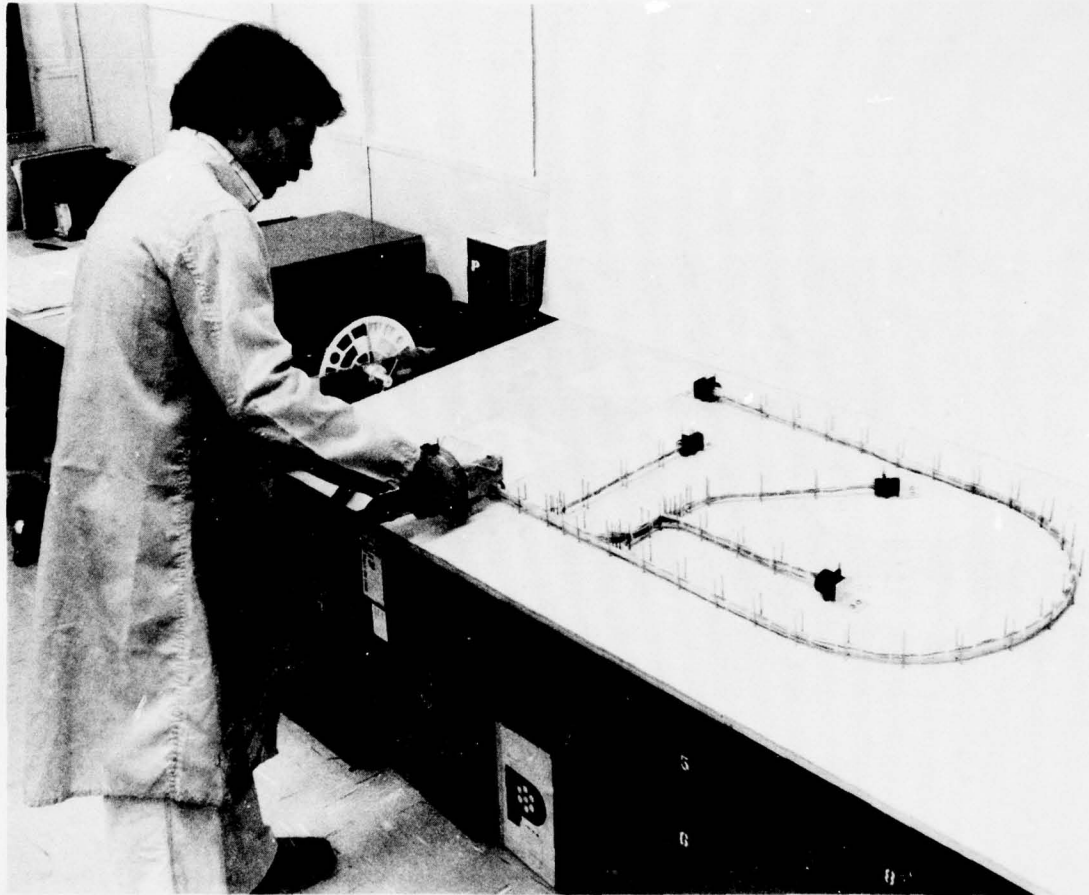

Figure 29. Manual Harness Tying

A mechanized harness-tying design was developed and studied as an alternative to the manual process. In this method, the storage unit is fastened to the machine cross-truss, and the tying head is incorporated into a programmed application mechanism. This mechanism is designed to hold the tying head, to move the unit up and down, and to rotate the head for positioning and orientation (Figure 30). As designed, a program calls for positioning runs that allow the ties to be applied for the first 6 inches from each connector. Additional ties are made back toward the harness center.

An industrial engineering study of the two tying methods showed that the average cycle time of the manual operation is 2.5 seconds for each tie. The cycle time for the automatic operation (which necessarily included the X-Y table run, orientation, descent and return of the tying head, and the

actual tying cycle) totals 3.2 seconds. When these factors are applied to the standard program sample harness and plotted against various production quantities, the resulting cost curves (Figure 31) show the automatic method cost is very high at low volumes, but decreases rapidly to approximately \$13 per harness at high production quantities. The corresponding manual operation costs were \$14 per harness for low volume, and approximately \$3 each in large quantities. However, since the cycle time for automatic operation is always longer than the manual cycle time, there is no cross-over point at which the automatic operation becomes more economical. Therefore, it is recommended that the Panduit tool be used in the manual mode for any level of production quantities (See Appendix A).

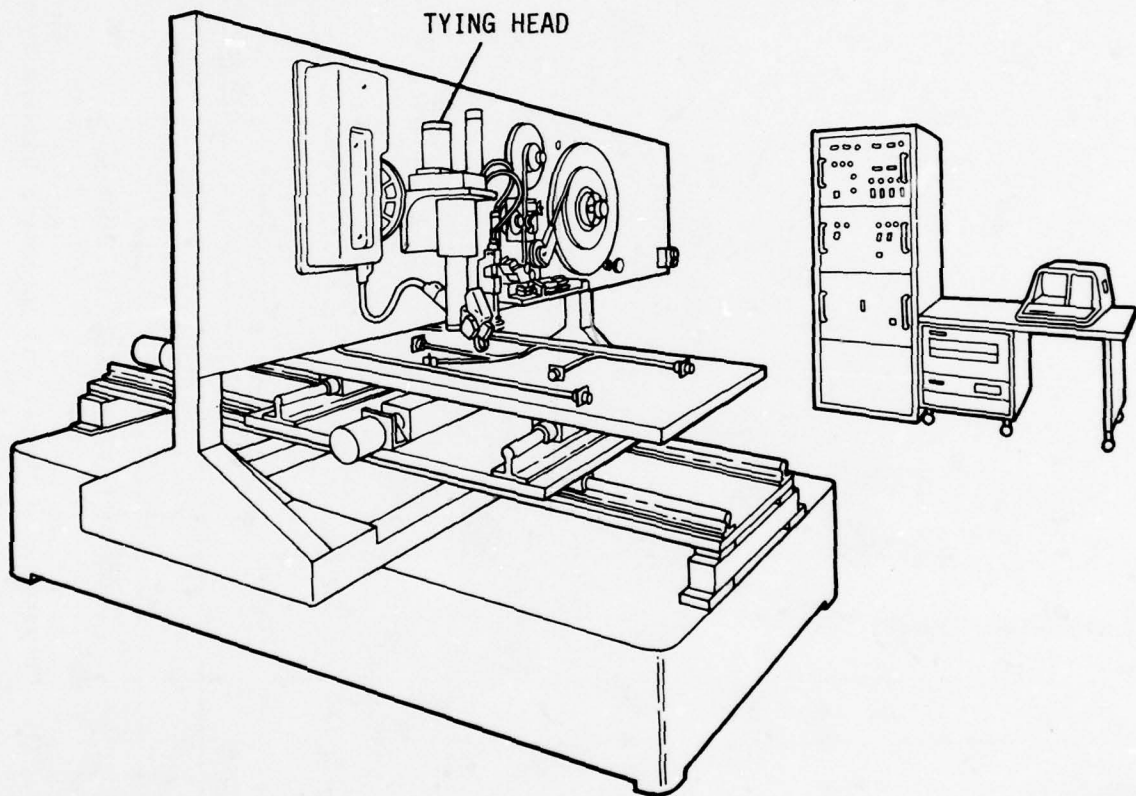

Figure 30. Automatic Harness Tying Concept

2.8 Facility Coordination and Verification

As each concept segment was developed and hardware was fabricated, the process and equipment were thoroughly checked. Where processes did not work as planned, revision and upgrading was undertaken with each process step until an acceptable alternate was developed. Examples of this include:

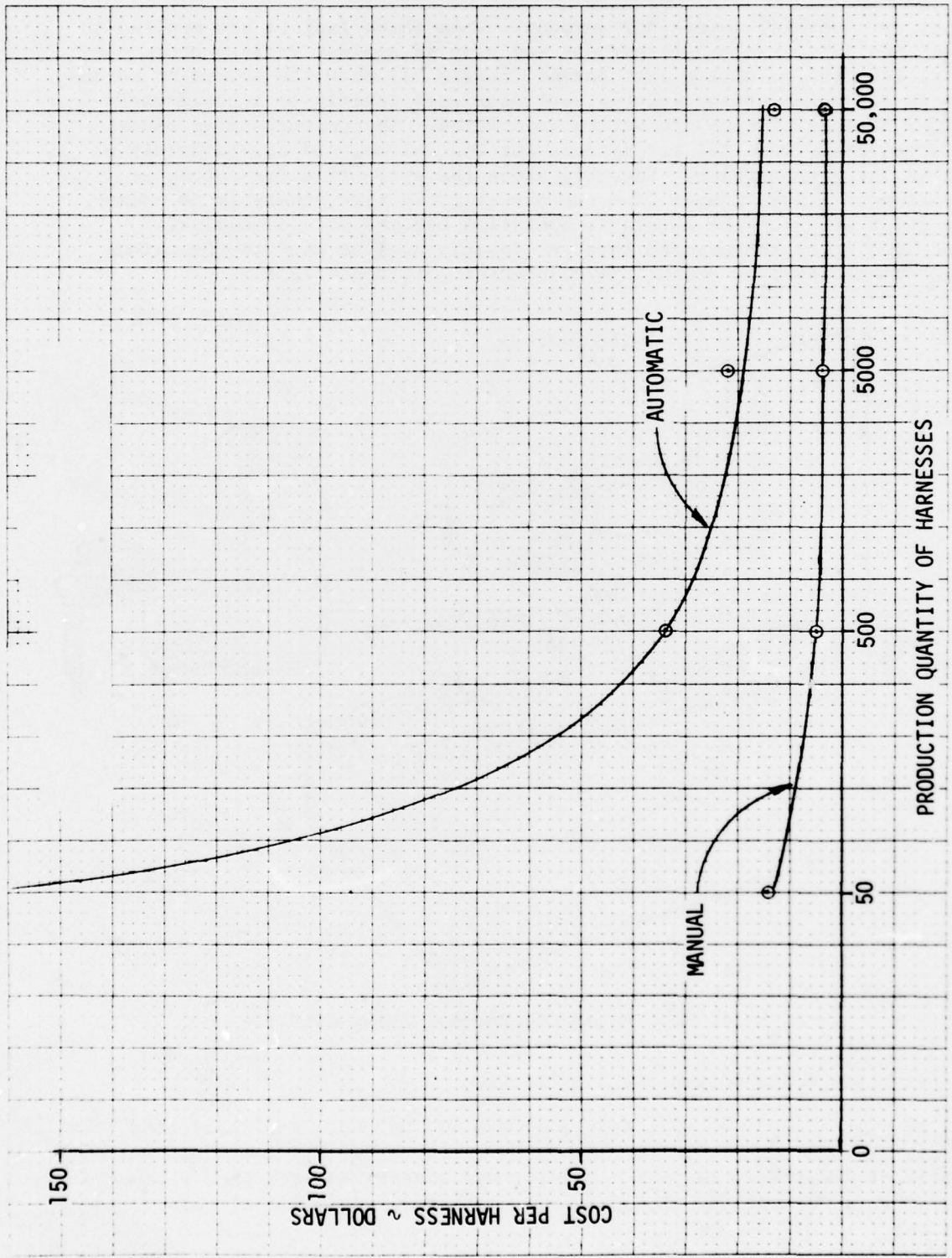

Figure 31. Comparison of Manual and Automatic Harness Tying Costs

- 1 The channel rubber wire carrier and storage system was replaced with the zipper tape system when the rubber channel carrier proved ineffective in controlling the wires reliably.
- 2 An auxiliary stepping motor drive for a slack wire condition in the insertion head was replaced with a more reliable microswitch and guide subassembly.
- 3 The insertion head was changed from a round body to a square body, so that alignment in a square recess was made more precise and replacement of parts became easier.
- 4 The guides on the tooling board required rework to allow more free space for the wires as the harness wires accumulated in the high density areas.

Each major machine unit or piece of hardware was checked for proper function. Experimental runs were made to verify that each segment of the process procedure was operating properly. Finally, all parts of the facility were brought on-line and demonstrated to the MICOM technical representative in the final review and industry demonstration held at Martin Marietta's Orlando plant on 1 February 1979. The agenda for the demonstration is shown in Appendix B, and the list of attendees is shown in Appendix C.

2.9 Documentation and Specifications

Documentation was maintained on all equipment and tooling during the development of the program. Design layouts, assembly drawings, detail drawings, and parts lists are on file for all of the hardware used, and are submitted per contract requirements with the final report. A complete list of drawings and purchased items is shown in Appendix F.

2.10 Operational Procedures Handbook

A contractual requirement of this program is the publication of an Operational Procedures Handbook. This document covers the setup and operation of each of the machine units fabricated as an operating part of the harness assembly facility. The operation of the microprocessor is included as a separate set of instructions. The handbook is included in this report as Appendix D.

2.11 Harness Design Handbook

To set up compatible parameters for the development and demonstration of the mechanized harness assembly concept, components and processes were selected that most readily fitted into the mechanization philosophies required for optimum payback. It was thus necessary to create a restrictive envelope of process rules, component designations, and operating conditions. The Harness Design Recommendation Handbook, Appendix E, covers these parameter restrictions that are required to design harnesses compatible with the current concept demonstration facility developed in this program.

2.12 Facility Scale Model

The facility scale model developed as a contractual requirement is shown in Figure 32. The total proposed facility is depicted, with the wire preparation equipment at the start of the process line. A proposed transfer device moves the wires into the terminated wire reeler as they are made. The reels are staged through the reel-to-reel sequencer and the harness assembly machine. All storage areas and staging areas are shown for reels, components, tooling boards, and drums. The overall dimensions and flow pattern of an actual fabrication facility are shown and can be used for size and equipment estimations.

2.13 Cost Studies

2.13.1 Manpower Only

This first section of the cost analysis was made of the sample harness assembly times, comparing the manual assembly process to the proposed automatic process. Fabrication times were estimated in accordance with established motion-time-measurement (MTM) procedures. Tables and graphs were constructed to compare automatic harness fabrication with manual fabrication in terms of total man-time, percent man-time, labor cost, percent labor cost, and percent span time. This section deals only with the time study comparison and assumes that both the manual and the mechanized facilities are already implemented. Data in this cost analysis and in Table I is derived from information published in the initial contract, reference No. DAAH01-74-R-1069.

The cost comparison of the present harness fabrication process to the proposed mechanized concept shows that mechanization can result in significant savings in time and money. However, these savings can be accomplished only if:

- 1 The harness design follows recommended design procedures that would make it compatible with mechanized processing, and
- 2 Production quantities are large enough to justify the capital outlay for the mechanized facility.

Assuming the ideal conditions of strict adherence to the prescribed harness design recommendations, optimum use of the mechanized concept, and current labor rates, the automatic fabrication of wire harnesses can show a saving of six to one over the current manual fabrication process.

Manual interface operations have been recognized as necessary for certain incompatible operations and were a part of the program plan from the start. The proportion of manual processing that is allowed to enter into the fabrication operation immediately reflects on the economies that can be realized through mechanization. The savings curve degrades rapidly as the manual portion increases.



Figure 32. Scale Model of Facility

TABLE I

Total Run-Time Cost Analysis

	Run Time per 100 Units (Hours)	Run Time per Unit (Hours)	Setup Time (Hours)	Percent of Manual (Excluding Setup)
Manual	2303	23	4.0	100
Automatic	328	3.3	2.0	14.35
80% Automatic/ 20% manual	500	5.0	2.4	21.75
Basis: Sample demonstration harness in 100-unit lots				

An estimated normal ratio of 80 percent mechanized to 20 percent manual processing has been assumed for practical usable harnesses. Savings have been charted in Table I. This practical ratio shows that savings of more than four to one can be realized by maintaining the 80/20 percentage ratio during fabrication.

2.13.2 Manpower and Equipment

The following equipment and process data are used in establishing a cost comparison between manual and automatic processing. The principle factors used in the cost study analysis are the recurring and the non-recurring production costs that occur as a result of planning, processing, and equipment amortization.

2.13.2.1 Harness Data

- A. Assume an average of three harnesses per missile.
- B. Equipment amortization spread over 10 years.
- C. Production rates and lot sizes:

Missile Quantities	Lot Size	Production Span Time (years)	Equipment Utilization (Percent)
50 (150 harnesses)	3	1	5
500 (1500 harnesses)	10	1	50
5000 (15000 harnesses)	100	2	83 (3 shifts)
50000 (150000 harnesses)	100	3	93 (3 shifts, 6 sets)

D. Harness (reference Figure 6)

The harness consists of five connectors (three 55-terminal and two 24-terminal); 106 wires (212 insertions); three breakouts; crimp-type terminals, rear entry, press-in and snap-in-place; 20-, 22-, and 24-gage wire; wire lengths from 27.5 to 93.5 inches.

2.13.2.2 Equipment and Material Cost (Nonrecurring) Data

The total system cost estimate over which the amortization costs in dollars are spread as follows:

Manual wire preparation	\$ 5,000
Terminated wire reeler	12,000
Reel-to-reel sequencer	30,000
X-Y table	44,000
Automatic wire dispensing machine	22,000
Microprocessor	22,000
Control System	30,000
Tying tool rental	300
Reels, racks, tapes	8,000
Facilities	10,000
Tooling	6,000
Miscellaneous	700
Total	\$190,000

Equipment amortization

$$\text{Cost/Hour} = \frac{\text{Equipment Cost} \times \text{Burden Constant}}{\text{Amortization Hours} \times \text{Equipment Usage\%}}$$

$$= \frac{\text{Equipment Cost} \times 1.313}{\text{Amortization Hours} \times \text{Equipment Usage\%}}$$

2.13.2.3 Manufacturing Planning Cost (Nonrecurring) Manhours Data

Plan and software for automatic processing	200 hr
Plan for manual processing	32 hr

Preparation cost of planning (MPP costs) is determined as

$$\text{MPP Cost} = \frac{\text{Quantity of Harnesses per Missile} \times \text{Preparation Time} \times \text{Burden Constant}}{\text{Burden Constant}}$$

2.13.2.4 Recurring Operating Cost Data (Manhours)

Setup for manual (each harness type)	3.95 hr
Setup for automatic (each harness type)	1.9 hr
Reloading of reels	0.3 hr
Runtime (recurring cost) for assembly of each harness	

Manual	23.0 hr
Automatic	3.3 hr
80 percent Automatic/20 percent manual	5.0 hr

2.13.2.5 Recurring Labor Cost Data (Dollars)

Industry average labor rate (assumed)	\$10.00
Industry average burden constant (assumed)	3.50
Labor costs = hourly rate x burden constant	
Shop labor = (Shop runtime + Shop setup time) x (labor cost)	
Industry average-burdened labor rate (assumed)	35.00

2.13.2.6 Analysis

Examination of the data summarized in Table II shows that the installation of a mechanized harness assembly facility is feasible and cost effective. With the ratio of 80 percent automatic to 20 percent manual processing, the figures show savings of more than three to one over the manual process, even when the capital write-off is included.

TABLE II

Cost Comparison of Manual versus Automatic Harness Processing - Total Cost in Dollars

Harness Production Quantities (3 X Missile No.)	MPP Costs Section 3		Equipment Usage Cost Section 2		Manpower Costs Sections 4 & 5		Total Burdened Assembly Costs		
	Manual	Auto-matic	Manual	Auto-matic	Manual	Auto-matic	Manual	Auto-matic	20/80
150	1,120	7,000	25,237	128,175	124,862	19,162	1,008	1,029	1,024
1,500	1,120	7,000	25,237	128,155	1,227,625	181,125	836	210	335
15,000	1,120	7,000	50,715	247,995	12,092,500	1,723,750	810	132	267
150,000	1,120	7,000	451,950	2,216,650	120,925,000	1,723,500	809	130	266

Schedules and funding availability may not warrant procurement of all the automatic harness equipment developed. Depending on the industry needs and the harness design requirements, individual automatic processing equipment could be implemented in predetermined high fabrication cost areas. As an example, a minimum of \$50,000 equipment cost could be saved by manually preparing and inserting the presequenced wires onto the automatic dispensing machine. Cost comparisons should be performed to determine the trade-off between the increased labor cost versus reduced equipment cost.

3.0 DELIVERABLE ITEMS

The deliverable items as delineated in the contract statement of work are as follows:

Reviews

Reviews were held at the option of the MICOM technical representative at Huntsville, Alabama, or at the contractor's facility. A final review was held at the contractor's facility at Orlando, Florida, to present the results of the program and to demonstrate the capability of the equipment.

Monthly and Quarterly Reports

Letter form reports were made each month together with a cost versus performance report. Formal quarterly reports were submitted with a brief description of the next quarter's activities.

Final Report

This final report presents a detailed summary of all program data. The report contains descriptions of the designs and processes developed for the facility and includes all cost data. An operations procedures handbook and a design recommendations handbook are included as a part of the final report.

Drawings and Prints

A full set of drawings and one set of prints detailing all designs and hardware were prepared and mailed to MICOM on February 28, 1979 per request of Mr. R. Kotler. All specifications are delineated.

Hardware

All hardware items required to demonstrate the concept were built and made operational as deliverable items.

Control System

A control system including a microprocessor and software to produce the demonstration results have been provided.

Facility Model

A scale model of the total facility as proposed, including storage areas and proposed equipment to process reels of wire into finished harnesses.

Videotape and Player

A videotape with video cassette player recorder and color monitor receiver.

4.0 PROGRAM RESULTS

This task and the preceding study program have developed a totally unique approach to harness fabrication and a new set of basic ground rules with which to implement the system. The concept assumes that the wire lengths of the harness can be predetermined and that all of the components can be prepared before the final assembly process. The concept also requires that compatible parts be specified in the harnesses so that optimum benefits may be derived from the mechanized assembly facility.

A mechanized laboratory facility has been implemented with full scale engineering prototype machines that have been used to make experimental runs and demonstrations. Sample harnesses have been successfully fabricated, and the concept has been verified as developed.

A Harness Design Recommendation Handbook has been developed and published to assist the harness designer to make the harnesses compatible with possible mechanization. A cost analysis has been completed that shows the reductions in time and cost that can be achieved by use of the mechanized harness facility. A system analysis was accomplished to determine what additional effort should be undertaken to increase the capability and flexibility of such harness fabrication facilities. A final review and industry demonstration was conducted on 1 February 1979 to bring all pertinent data before interested parties in aerospace, commercial, and machine manufacturing industries. A complete description of the concept and equipment was given, and a functional demonstration of the machinery was presented.

5.0 CONCLUSIONS AND RECOMMENDATIONS

5.1 Conclusions

As a result of this program, the following conclusions were reached:

The concept for the mechanized assembly of cables and harnesses has been shown to be achievable and practical. All of the basic conceptual factors determined in the previous contractual work (reference contract No. DAAH01-74-C-1069) have been verified and demonstrated in practice.

Acceptable harness assemblies were made using precut and preterminated wires fabricated prior to the assembly procedure and in accordance with a wire list. Costly custom fabrication during the assembly process is not necessary and can be incorporated into the preliminary wire preparation phase using previously demonstrated equipment.

Many of the twisted pairs and shielded wires currently specified in harnesses were found to be unnecessary to the design function of the unit. Processing costs are increased, where these wires are specified, due to the higher number of manual operations required during assembly. With careful planning and design, a larger percentage of the harness wires can become automation-compatible and increase the potential savings through use of the mechanized facility.

Additional development effort could substantially advance the capability and flexibility of the harness assembly equipment toward a production-type facility. This equipment can be made capable of handling a large variety of connectors and wires, so the designer is not faced with unworkable restrictions in his harness designs.

Conversely, the harness designs and components must be simplified and standardized so the designer, the components, and the equipment become a more effective functioning loop that creates optimum designs in shorter turnaround times and at lower cost.

The studies and searches conducted during the previous program demonstrated a pressing need for wire preparation equipment that will perform a more complete function than those available today. Eight major companies, both aerospace and commercial, were visited, and harness presentations made. All companies except Emerson Electric believed that they would

eventually be forced from their present manual harness manufacturing practices into a mechanized facility because of inflation. Companies such as General Dynamics, Collins Radio, Boeing, Beech Aircraft, and McDonnell Douglas Corporation also believe that standardization and harness design for automation will be forced on both Engineering and Manufacturing to achieve the mechanization goal (Reference Appendix A, Trip Report, Sixth Quarterly Progress Report, OR 14,151-5, September 1977).

➤ The cost studies ~~described in section 2.19~~ have shown that more than a 75 percent savings can be achieved with nominal care in design and use of mechanized harness assembly facilities. ←

5.2 Recommendations

Recommendations made as a result of this program are as follows:

- 1 Harness assembly procedures should be altered and implementation started on the first phase of the transition to more economical harnesses. Wherever possible, wire lists should be prepared and wires precut and preterminated, so that only assembly work is done at the assembly station. This transition could be made without affecting the present system. On the other hand, economies could be realized that would make the benefits apparent immediately.
- 2 Design regulations should be published, requiring justification for the use of twisted pairs or shielded wires before acceptance, as a part of a harness design. When the justification is accepted, the wires would become a part of the harness design.
- 3 The harness designer and other interested personnel should confer early in a program, so configurations and component specifications can be controlled and altered for optimum compatibility with potential automation.
- 4 A set of standardized and simplified harness components should be specified for automated fabrication potential. Justification should be required for use of components not in this group.
- 5 Additional development effort should be initiated in five major areas to expand the capability and flexibility of the harness facility. To develop this potential, the tasks in paragraphs 5.2.1-5.2.5, below, indicate the necessary areas of effort that would best advance the capability of the prototype harness fabrication facility into a functioning production line.

5.2.1 Executive Software Program - The basic program definition specified a sample harness and prototype equipment to prove out the concept. The next logical advance is the addition of an executive program that can be incorporated into the system software so that any harness designed within

the capabilities of the facility can be programmed through the system for mechanized fabrication. This program will allow untrained personnel to prepare harness programs with a minimal amount of indoctrination. Approximate funding requirements for this program would be:

		<u>Manmonths</u>
<u>1</u>	Determination of approach and evaluation	
	Electrical	2
	Mechanical	2
<u>2</u>	Development of executive program and tooling	
	Electrical	6
	Mechanical	4
<u>3</u>	Equipment	
		<u>Dollars</u>
	Printer	\$ 4,800
	Accessories	1,200
	Tooling	4,000
	TOTALS	<u>\$10,000</u>
		<u>14</u>

5.2.2 Insertion Head Adaptation - The basic program definition specified one type connector and terminal to prove out concept. Follow-on effort is necessary to expand capability of insertion head to accept and process a variety of connectors and terminals in order to allow flexibility of harness design. Funding requirements for this program would be:

		<u>Dollars</u>	<u>Manmonths</u>
<u>1</u>	Conceptual design and development		
	Mechanical	-	7
<u>2</u>	Final design fabrication and test		
	Mechanical	-	6
<u>3</u>	Material and test parts	\$5000	-
	TOTALS	<u>\$5000</u>	<u>13</u>

5.2.3 Graphic Design Development - The present state of the art in printed circuit board design and layout has advanced to the point where finished printed circuit layouts and the associated documentation are generated from schematic input using computer programs and graphics terminals. Printed circuit layouts are developed by direct input of interconnection data, automatic placement of components, automatic routing of printed circuit paths, and operator editing, using light-pen commands at the graphic terminals.

This capability, could be easily adapted to the design, layout, specification, and documentation of harnesses, with only minor development effort.

The major effort will be directed toward determination of the proper data input and output to be incorporated into the new program, and the preparation and editing of the software package. Funding requirements for this program would be:

	<u>Dollars</u>	<u>Manmonths</u>
Engineering development	-	9
Data systems development	-	4
Mechanical engineering	-	4
Materials	\$ 8,000	-
Outside software procurement	<u>40,000</u>	<u>-</u>
TOTALS	\$48,000	17

5.2.4 Upgrade Wire Capture and Handling System - Capture and control of the terminated wires is presently achieved by laying the wires in a grooved slot in a continuous two-piece nylon zipper tape in the proper orientation and sequence. The tape is closed around the wire as a carrier and the carrier is wound on reels for storage until required at the harness assembly operation. Difficulties in controlling the carrier and going through the various steps of sequencing and coordinating make the total wire handling problem cumbersome and costly. A program should be initiated to develop a more reliable wire handling system, with effort towards elimination of the carrier tape and the reels. The wire handling system could be greatly improved by development of an automatic wire preparation system that would measure, cut, strip, and terminate the required wire, and feed it directly into the assembly machine without the reels, zipper tape, staging, or coordination. Funding requirements for this program would be:

	<u>Dollars</u>	<u>Manmonths</u>
Conceptual design and development	-	24
Final design, fabrication and test	-	24
Material	<u>\$40,000</u>	<u>-</u>
TOTALS	\$40,000	48

5.2.5 X-Y Table - The size of the X-Y table must be considered in any future production module designs. Careful determination of the proper table size is necessary when selecting an X-Y assembly unit, to ensure that the working area is large enough to accept the harnesses planned for mechanized assembly. Practical assembly modules can be produced with tables up to 6 feet by 12 feet or larger, and require only the selection of a competent manufacturer during the procurement phase. Careful planning of the tooling can further increase the harness size by means of folding of the harness runs on the board.

It is recommended that the Executive Software Program (Item Number 1) be implemented before the Graphic Design Development Program (Item Number 3) during this stage of development, so the task team can develop the data

and experience necessary to conduct the Graphic Design Program. This approach would optimize the graphic design efforts later by eliminating the many blind avenues of effort that will be delineated by using and gaining experience on the equipment with the Executive Software Program.

After these five areas are complete the resulting harness facility would be a functional production tool that could be manned by personnel of nominal aptitudes, and with practical processes that would result in reduced costs and shorter turnaround time.

5.2.6 Equipment Availability - The program is now complete, with all equipment documented and implemented. The total complement of equipment demonstrated in the full scale engineering prototype facility, along with the associated documentation, is currently available on a no-cost loan basis from the Government for additional development, or for production implementation. Any company involved in Government contract work is eligible to submit a request for this equipment.

Delivery of this final report and the accompanying documentation constitutes completion of all contractual documentation for the contract.

APPENDIX A

COMPARISON OF MANUAL AND AUTOMATIC MACHINE TYING OF HARNESES

GENERAL

Information included within this Appendix was taken from reports published by Martin Marietta Orlando Division, under contract number DAAH01-76-C-0452, "Application Of Automated Manufacturing Process To Methods For Affixing Electrical Connectors to Cables."

Cost studies comparing manually operated semi-automatic tying equipment (Figure A-1) and fully automated tying equipment (Figure A-2) were completed under previous contract efforts.

Both tying concepts employ the use of self-locking plastic tie straps around wire bundles, which comply with Missile Specification MIS 11293C.

Spacing and tension of self-locking plastic tie straps on various diameters of wire bundles are described in this specification. The tying operation employing either method would be performed in the final harness assembly process following the layout of the wires by an automatic wiring and connector insertion machine.

The automatic tying operation will be performed as a separate component of the automatic wiring assembly machine employing the same X-Y table and its computer control system to actuate the movement of the harness from point to point location under an automatic tying head. The add-on components for support and cycling of the harness tying tool consist of carriage and drive system. For the manual method, the X-Y table would not move to programmed tying positions. The operator would place the tying head at the locations marked on the tooling board for each tie strap.

MANUAL

The manual tying method shown in Figure A-1 features the use of a conventional semi-automatic tying tool. The two major parts of the tying system consist of a tying tool and a remote tie strap dispenser. The operator is holding the tying tool and has completed the tying process on a typical harness assembly. Figure A-1 shows the harness assembly on a conventional harness tooling board, but in the proposed production procedure, this operation is performed on the X-Y table tooling board immediately after the automatic assembly process is completed. For each tie strap, the operator manually positions the tying tool jaws around the bundle of harness wires. Triggering of an air valve switch on the tool handle effects

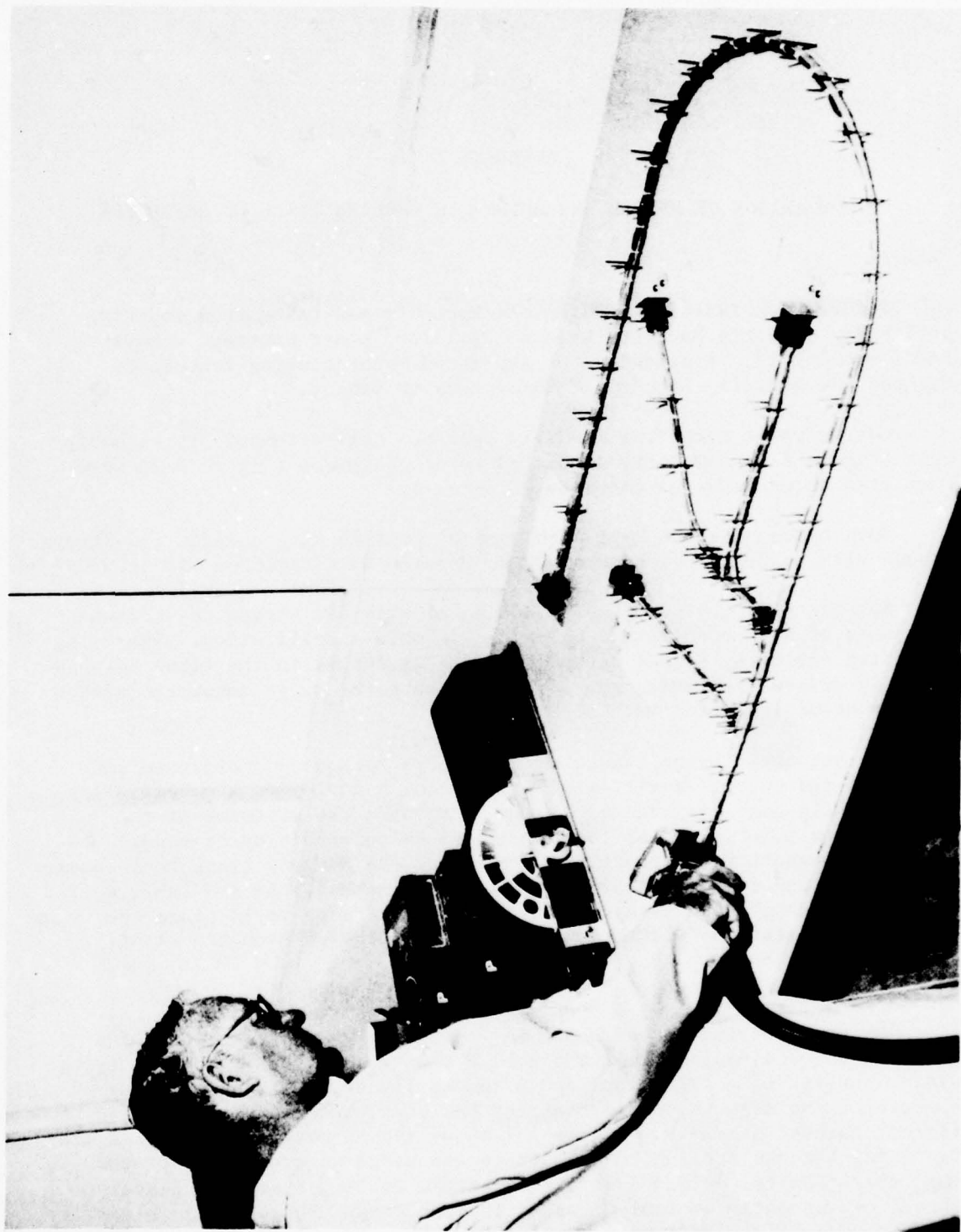

Figure A-1. Manual Tying Operation Demonstrating Use of Panduit Tying Tool

automatic feed of a tie strap from the dispenser and wraps it under tension around the wires. The tying tool is moved from point to point around the profile of the harness for each strap. Dispensing of the tie strap and trimming after clinching of the strap is automatic. During usage an audible signal notifies the operator when the magazine in the dispenser is empty. Replacement of the empty magazine is a manual operation. An average tying cycle is 2.5 seconds for each tie strap. The unloading and reloading of a magazine of 100 tie straps is 55 seconds. The tool is used to tie straps around wire bundles ranging in size from 1/16 to 3/4 inch diameter.

The tie strap machine shown in Figure A-2 features the use of a conventional tying tool with mechanical and electronic controls to position and actuate the tying mechanisms automatically. An X-Y table is programmed under computer control to move the harness in a point-to-point mode under the tying tool head for location of each tie strap. At the end of travel to install a tie strap, the computer commands are used to cycle the tying tool to place and tie a plastic strap around the bundle of wires. The sequence of tying operations for a complete tying cycle takes five steps. A total tying cycle of 3.2 seconds is required for each tie strap, as follows:

- 1 The X-Y table moves the harness in incremental steps for tie location under the tying tool.
- 2 While the X-Y table is moving, a stepping motor rotates the tying tool to position its jaws perpendicular to the wire bundle. Capability of 180° movement exist.
- 3 The tying tool moves down and closes the tie strap jaw around the bundle of wires.
- 4 The tying tool is triggered to release and clinch a tie strap around the harness.
- 5 After tying, the tie strap jaw is opened and the tying tool moves up to clear the gates supporting the harness. The X-Y table moves harness to another tie location

The actual cost analysis was required to establish the most efficient, cost-effective method of installing tie straps. The basis for the cost trade-off comparison is the sample harness assembly shown in Figure A-3. This representative harness in size and configuration for missile applications can be laid out on a tooling board by the automatic wiring machine developed in this program.

Cost Analysis Data

Data depicted in Table A-I is extracted from information compiled during the previous contractual effort (Reference No. DAAH01-74-R-1069).

The cost summary depicted in Table A-I provides easy comparison between manual and fully automated tying operations.

Total burdened assembly costs for both manual and automatic operations are shown in Figure A-4. Regardless of the production quantities, the manual tying method which employs the hand held conventional tool is more cost effective and faster than the fully automated method.

In addition to the amortization cost of an automatic machine, the higher cost of the automatic method is due mainly to the required presence of an operator to monitor the machine operation.

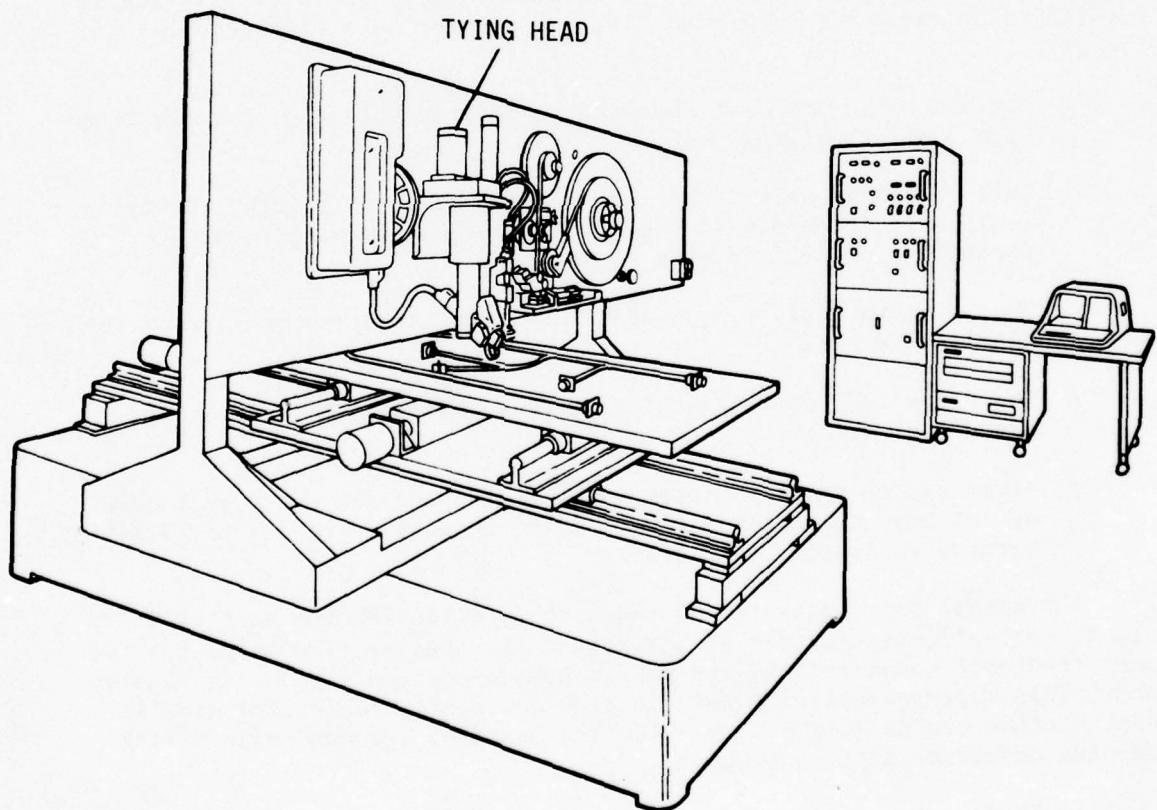

Figure A-2. Concept of an Automatic Tying Machine using a Panduit Tool in a Computer Controlled Indexing Head

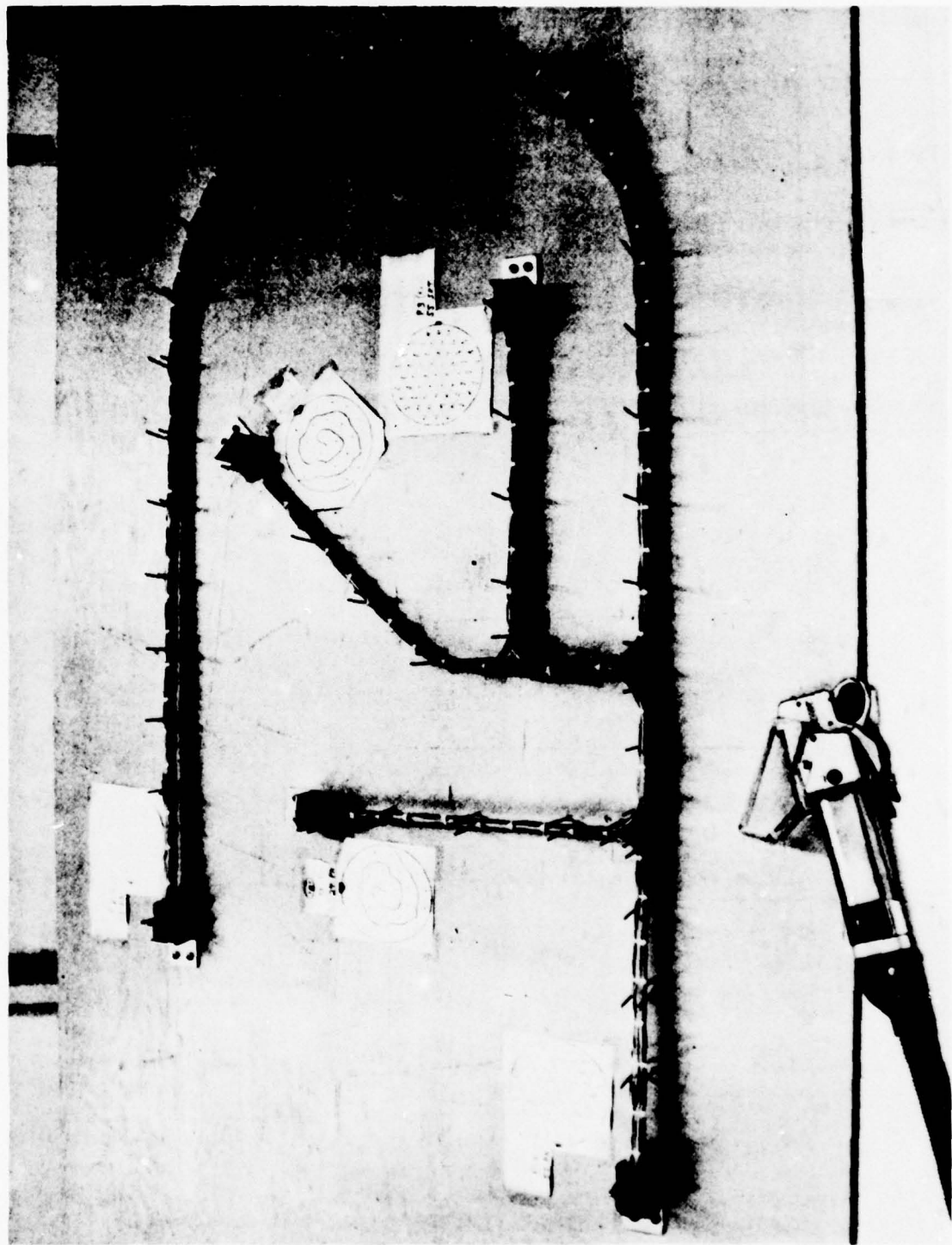

Figure A-3. A Representative Sample of a Missile Harness Assembly

TABLE A-I

Cost of Comparison of Manual Versus Automatic Machine Tying (dollars)

Production Harness Quantity	MPP Costs Ref. 3.0		Equipment Usage Cost Ref. 2.0		Manpower Costs Ref. 4.0 & 5.0		Total Burdened Assembly Costs	
	Manual	Auto-matic	Manual	Auto-matic	Manual	Auto-matic	Manual	Auto-matic
50	321	7,270	8.58	1,543	202	352	10.42	183.00
500	321	7,270	51.47	7,412	2,020	2,817	4.58	34.30
5,000	642	15,000	514.70	68,627	20,204	26,081	4.06	21.70
50,000	963	21,000	2,818.70	378,309	202,040	258,900	3.91	12.90

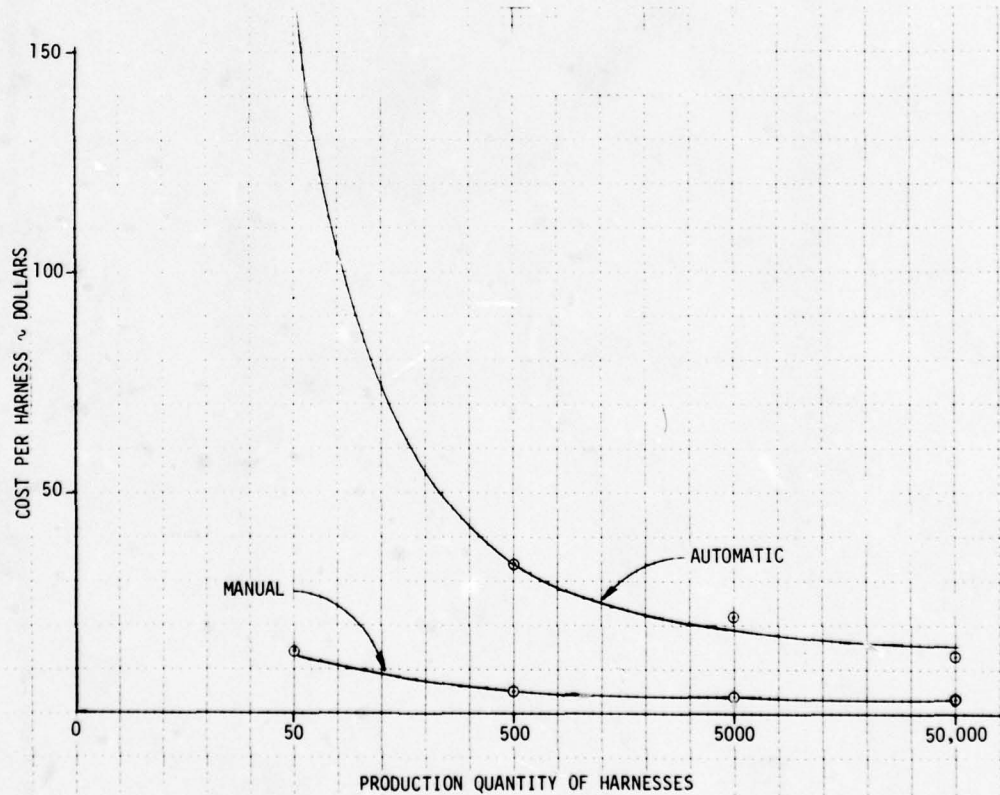

Figure 31. Comparison of Manual and Automatic Harness Tying Costs

Figure A-4. Comparison of Manual and Automatic Harness Tying Costs

APPENDIX B

AGENDA - INDUSTRY DEMONSTRATION
APPLICATION OF AUTOMATED MANUFACTURING PROCESS TO
METHODS FOR AFFIXING ELECTRICAL CONNECTORS TO CABLES
CONTRACT DAAK40-76-C-0452

MARTIN MARIETTA AEROSPACE
ORLANDO DIVISION
ORLANDO, FLORIDA

0800 - 0830	Registration	Main Lobby
0830 - 0840	Welcome	Richard P. Malena
0840 - 0900	MIRADCOM MM&T Program Overview	MIRADCOM Representative
0900 - 0920	Program Introduction	George G. Myers
0920 - 0940	Program Background	Frederick E. Tartaglia
0940 - 1000	Coffee	
1000 - 1140	Harness Machine Technology	Frederick E. Tartaglia
1140 - 1200	Videotape	Frederick E. Tartaglia
1200 - 1245	Demonstration (Terminated Wire Reeler and Reel-To-Reel Sequencer)	Frederick E. Tartaglia
1245 - 1345	Lunch	
1345 - 1415	Demonstration (Harness Assembly Machine)	Frederick E. Tartaglia
1415 - 1430	Open Discussion	Frederick E. Tartaglia
1430	Adjournment	

APPENDIX C

ATTENDEES - INDUSTRY DEMONSTRATION

1 February 1979

Name	Company	Location	Requested Final Report
Bobby Austin	MIRADCOM	Redstone Arsenal, AL	
Mike L. Moon	General Dynamics	Fort Worth, TX	
Greg A. Longnet	General Dynamics	Fort Worth, TX	Yes
E.C. Dawson	General Dynamics	Fort Worth, TX	
Robert O. Dusal	Artos Engineering Co.	New Berlin, WI	Yes
J.B. Abjanic	Convair General Dynamics	San Diego, CA	
J.H. Ward	Convair General Dynamics	San Diego, CA	Yes
Robert L. Boldy	Rockwell International	Richardson, TX	Yes
Jerry Smith	Rockwell International	Dallas, TX	Yes
Dave Kelly	Balmar Crimp Tool Corp.	Orlando, FL	Yes
Len Drake	Balmar Crimp Tool Corp.	Orlando, FL	Yes
A.D. Godino	Hughes Aircraft Co.	Canoga Park, CA	
Ernie Ferrier	Henry Mann, Inc.	Orlando, FL	
Henry Mann	Henry Mann, Inc.	Orlando, FL	
Tom C. Fennell	Honeywell	St. Petersburg, FL	Yes
J. Huggins	Chrysler	Cape Canaveral, FL	Yes
E. Perry	Chrysler	Cape Canaveral, FL	Yes
Dennis Borvta	Honeywell	Hopkins, MN	Yes
Bill Champion	Honeywell	Tampa, FL	Yes
William Malavich	Raytheon	Bedford, MS	Yes
J.D. Newton	Lockheed	Marietta, GA	Yes
Edward Eubanks	Eubanks Engineering	Monrovia, CA	Yes
Jay Patel	Eubanks Engineering	Monrovia, CA	
Ronald D. Sell	Boeing	Wichita, KS	Yes
Robert D. Lewis	Boeing	Wichita, KS	Yes
Michael J. Lettini	Boeing	Seattle, WA	Yes
Robert H. Pellerin	Raytheon	Andover, MS	Yes
George J. George	Bendix Corp.	Teterboro, NJ	Yes
D.D. Kelly	Bell Helicopter	Fort Worth, TX	Yes
E.L. Hughes	Bell Helicopter	Fort Worth, TX	Yes
R.R Sifferd	Martin Marietta	Orlando, FL	Yes
B.J. Klassen	Martin Marietta	Orlando, FL	Yes
W.S. Bowden	Martin Marietta	Orlando, FL	Yes
A.T. Hamill	Westinghouse	Baltimore, MD	Yes

APPENDIX D
OPERATIONAL PROCEDURES HANDBOOK

February 1979

Martin Marietta Corporation
Orlando Division
P. O. Box 5837
Orlando, Florida 32855

CONTENTS

Terminated Wire Reeler (TWR) Operation	D-3
Reel-to-Reel Sequencer Operation	D-6
Tooling Board Operation	D-12
Tying Operation	D-14
Microprocessor Operation	D-15
Harness Assembly Operation	D-20

TERMINATED WIRE REELER (TWR) OPERATION

DRAWING NO. F10000

MATERIALS

Tape (Upper) - Velcro loop tape, type 2000, unnapped No. 0620022000199AS - in 100 yard lengths with 20 feet of tape leader added to each end. VELCRO Corporation, Montclair, New Jersey.

Tape (Lower) - Velcro hook tape No. 65 - No. 0620652000199AA - in 100 yard lengths, with a 1/8-inch wide groove down the center of the tape with all hooks removed and with 10 feet of tape leader added to each end. VELCRO Corporation, Montclair, New Jersey.

Storage Drums - Cardboard - 14-inch diameter by 19 inches high (two required for each reel).

Reel - 24-inch diameter wire storage reel, Drawing No. D10200.

CAUTION - DO NOT FORCE THE DRIVE SYSTEM IN EITHER DIRECTION. USE MANUAL JOG BUTTON TO TURN REEL FORWARD. LOOSEN HAND KNOB AND BACK REEL OFF FROM DRIVE KEY TO TURN REEL BACKWARD.

PROCEDURE

- 1 Power up equipment by pulling out red power button.
- 2 Place a 100-yard length of upper loop tape into a storage drum with no twists in the tape, and place it beneath the rear (right) pickup assembly.
- 3 Place a 100-yard length of lower hook tape into a storage drum with no twists in the tape. Position it beneath the front (left) tape pickup assembly.
- 4 Load the empty 24-inch diameter reel on the windup shaft, and engage the drive key by pressing and turning the reel. Tighten the hand knob.
- 5 Switch to MANUAL operating mode.

- 6 Pass the end of the leader of the loop tape through the rear pickup assembly by lifting the tension foot and sliding the tape upward through the slot in the assembly so that the loop side is facing upward. Pass the tape over the two upper idler rolls and around the upper roller at the wire entry. Pull the tape through approximately 30 inches.
- 7 Pass the end of the leader of the hook tape through the front pickup assembly by lifting the tension foot and sliding the tape upward through the slot in the assembly so that the hook side is facing to the left. Pass the tape around the lower roller at the wire entry. Pull the tape through approximately 30 inches to match the upper tape.
- 8 Run the two tape leaders over the hub of the large wire storage reel, and pull the ends through the center access hole. Fasten the ends of the tape to the side of the reel with masking tape. Wind one to two turns of tape on the reel by pressing the JOG button.
- 9 Switch to AUTO mode. The machine is ready for operation.

AUTOMATED PROCESS

If the machine is to be fed automatically by the transfer conveyor, nothing further is required beyond standard monitoring of the automatic operation to check for malfunction. There are no malfunction safeguards on this engineering prototype design.

When the transfer conveyor has fed the proper number of wires to the TWR, determined by the wire running list and the wire preparation equipment program, no more wires will be fed from the transfer conveyor, and the equipment will stop.

All of the 20-gage wires will be fed in the sequence shown on Drawing No. E40008 from the column marked "REEL NO. 1." This reel will be identified as "20-1." When additional reels are required to store the 20-gage wires in the wire list, they will be identified as "20-2," "20-3," etc.

The 22-gage wires from the REEL NO. 2 column are similarly stored on reels identified as "22-1," "22-2," etc.

The 24-gage wires from the REEL NO. 3 column are stored on reels identified as "24-1," "24-2," etc.

NONAUTOMATED PROCESS

When the transfer conveyor is not used ahead of the TWR, the wires must be fed into the TWR manually in the sequenced order that they will be fed to the harness assembly board and in the same direction (leading end first). The machine will be operating under AUTO mode. The correct number of wires will be fed manually, according to the wire running list.

REMOVAL PROCEDURE

- 10 Switch to MANUAL operation.
- 11 Use the JOG button to run the remaining tape and trailer out of the storage drums.
- 12 Press the ends of the tapes through the hole provided in the rim to keep the tapes from unwinding.
- 13 Identify the reel contents.
- 14 Remove the reel and store it in the rack in the Staging Area.
- 15 Power down the equipment.

CONTROLS

- 16 The machine is powered up by means of a pull-push button. Power is turned ON by pulling out the button and turned OFF by pushing it in.
- 17 The BRAKE ADJUST controls the stopping time on the wire pickup reel by means of an electro-brake on the wire reel shaft.
- 18 The CLUTCH ADJUST controls the strength of the clutch engagement between the drive motor and the main reel shaft. This adjustment controls the tension of the sandwich between the entry and the reel.
- 19 Separate tension adjustment for each of the tapes is available on each of the tape pickup assemblies. Adjustable studs on each pickup assembly can be used to vary the pressure of the slide pad on each tape.
- 20 An adjustable time delay relay is provided inside the cabinet to delay the stop of the reel after the wire end passes the sensing microswitch in order to adjust the distance between the wires as they are wound on the reel.

REEL-TO-REEL SEQUENCER OPERATION

DRAWING NO. F-30000

MATERIALS

Tape (Upper) - Velcro loop tape, type 2000, unnapped No. 0620022000199AS - in 100-yard lengths with 10 feet of tape leader added to each end. VELCRO Corporation, Montclair, New Jersey.

Tape (Lower) Velcro hook tape No. 65 - No. 0620652000199AA - in 100-yard lengths, with a 1/8-inch wide groove down the center of the tape with all hooks removed and with 10 feet of tape leader added to each end. VELCRO Corporation, Montclair, New Jersey.

Storage Drums - Cardboard - 14-inch diameter by 19-inches high. (Two required for each reel. Total: eight drums per setup.)

Reels - 24-inch diameter wire storage reel, Drawing No. D10200.

CAUTION - DO NOT FORCE THE DRIVE SYSTEM IN EITHER DIRECTION. USE MANUAL JOG BUTTON TO TURN REEL FORWARD. LOOSEN HAND KNOB AND BACK REEL OFF FROM DRIVE KEY TO TURN REEL BACKWARD.

PROCEDURE

Lower Collector Unit (Reel "0")

- 1 Power up the equipment by turning the power switch on the main console to SYSTEM.
- 2 Move power switch on the left side of the lower unit to the ON position (up).
- 3 Verify that all four torque motor switches are OFF (to the left).
- 4 Swing the torque arm out of the reel slot, and set it on the retaining pin.
- 5 Place a 100-yard length of the loop tape into a storage drum with no twists in the tape. Position it beneath the left side pickup assembly.

- 6 Place a 100-yard length of the hook tape into a storage drum with no twists in the tape. Position it beneath the right side pickup assembly.
- 7 Load the empty 24-inch diameter reel on the windup shaft and thread on and tighten the red locking hand knob. Press the reel inward and turn the locking knob until the drive key aligns with and falls into the drive slot. Remove the locking knob, and thread on and tighten the regular hand knob.
- 8 Pass the end of the leader of the loop tape through the left pickup assembly by lifting the tension foot and sliding the tape upward through the slot in the assembly so that the hook side is facing to the left. Pass the tape over the idler roll and around the left entry roller. Pull the tape through approximately 30 inches.
- 9 Pass the end of the leader of the hook tape through the right pickup assembly by lifting the tension foot and sliding the tape upward through the slot in the assembly so that the loop side is facing to the right. Pass the tape around the external idler, through the drive rollers by latching the rollers open, then over the right entry roll (flanged). Pull the tape through approximately 30 inches to match the hook tape.
- 10 Run the two tape leaders around the hub of the wire storage reel, and pull the ends through the center access hole. Fasten the ends of the tape to the side of the reel with masking tape and wind one or two turns of tape on the reel manually.
- 11 Remove the torque arm from the retaining pin and allow it to swing in against the tape in the reel.
- 12 Move manual torque motor switch "0" on the main console to the right (to the ON position), and press the RUN button to start the torque motor and pick up the slack in the tape. Press the stepping motor button "0" momentarily to check the tape release and windup action of the lower collector system. Press the HALT button.
- 13 Move the torque motor switch "0" to the OFF position (to the left).

Upper Dispensing Units (Reels No. 1, 2, and 3)

- 14 Place the torque arm of upper position No. 1 on the retaining pin.
- 15 Select the reel containing the first series of 20-gage wires (Reel No. 20-1), and place it on the reel shaft on the upper Section No. 1. Engage the drive key as described in Step 7. Tighten the hand knob.

- 16 Place two empty storage drums in position under the tape dump capstans.
- 17 Unreel the tape leaders and thread them through the entry separator wheels and over the idler wheels.
- 18 Pass the upper (hook) tape around the outer idler on the capstan drive assembly and then through the drive wheels of the stepping motor and into the storage drum.
- 19 Pass the lower (loop) tape through the drive wheels of the torque motor and into the storage drum.
- 20 Remove the torque arm from the retaining pin, and allow it to swing in against the tape in the reel.
- 21 Move the manual torque motor Switch No. 1 to the right (to the ON position) and press the RUN button. Check that both torque motors are activated.
- 22 Press the stepping motor button No. 1 momentarily to check the windup action of the No. 1 dispenser system. Press the HALT button.
- 23 Place the torque arm of upper Position No. 2 on the retaining pin.
- 24 Select the reel containing the first series of 22-gage wires (Reel No. 22-1), and place it on the reel shaft of the upper Section No. 2. Engage the drive key as described in Step 7. Tighten the hand knob.
- 25 Repeat steps 16 through 22 on upper Section No. 2 using No. 2 for No. 1.
- 26 Repeat steps 14 through 22 on upper Section No. 3 using Reel No. 24-1 and No. 3 for No. 1.

AUTOMATED PROCESS

Microprocessor Operating Procedure

Insert the proper floppy discs into the slots in the microprocessor. Move the three switches on the microprocessor lower panel to the UP position.

Caps: lock on (keyboard).

Power up by switching to SYSTEM ON (the black switch on the console).

- 1 Type DX. This brings up the RT11 program.
(The disc operating system "executive" program)

- 6 Press RETURN key.
- 7 Repeat steps No. 5 and No. 6 until complete sequence is registered.
- 8 To close out sequence, type in 0,0.
- 9 CRT will display which torque motor switches to turn on and which to turn off.
- 10 Switch CBI on side of reel-to-reel frame to ON position.
- 11 Per CRT, depress RUN button on console.
- 12 Type GO.

REMOVAL PROCEDURE

Lower Collector Unit (Reel "0")

When the lower collector reel is full, use the following procedure:

- 1 Press stepping motor button "0" and the RUN button on the main console. Run on all remaining Velcro tape. Press HALT button.
- 2 Swing torque arm out of reel slot and set it on the retaining pin.
- 3 Remove the full reel and press the ends of the tape into the retaining hole on the rim. Identify the reel and place it on the staging rack.
- 4 Remove the empty drums.
- 5 Repeat Steps 5 through 13 in Lower Collector Unit (Reel "0") procedure.
- 6 Press RUN button on console.
- 7 Type GO.

Upper Dispensing Units (Reels No. 1, 2, and 3)

When an upper dispensing reel is empty (example: Reel No. 1 will be used), use the following procedure:

- 1 Press stepping motor button "1" and the RUN button on the main console. Run off the remaining Velcro tape. Press the HALT button.
- 2 Swing torque arm out of reel slot and set it on retaining pin.
- 3 Remove the empty reel and the tape drums.

- 4 Select the next full reel in the sequence and place it on the reel shaft of the upper section. Engage the drive key as described above. Tighten the hand knob.
- 5 Repeat Steps 16 through 22.
- 6 Press the RUN button on console.
- 7 Type GO.

TERMINATION PROCEDURE

After all wires are run proceed as follows:

- 1 Press the stepping motor button for each active reel in the system, and then the RUN button at the same time. Run the remaining tape through at each reel. Press HALT button.
- 2 Swing the torque arms out of reel slots and onto the retaining pins.
- 3 Press the ends of the tape on the full reel into the retaining hole in the rim. Identify the reel.
- 4 Remove all reels and drums and place them in their proper racks.
- 5 Open CB-1 switch on the side of the lower collector unit.
- 6 Turn the power switch on the main console OFF (vertical position).

TOOLING BOARD OPERATION

DRAWING NO. F-40000

The tooling board is made up of a 1/2-inch thick aluminum base plate that can be adapted to any specified harness configuration that lies within the space limitations of the equipment (24 by 48 inches).

The base plate supports connector holding fixtures that are located and clamped in position. Spacer blocks are mounted on the base plate to support an upper level of plywood that carries the guides and latches that delineate the harness and positions the wires as they are run out into the harness configuration. The base plate, with two sides accurately machined, is accurately mounted to the X-Y table against three locating pads. The edges act as a reference for locating the connector holding fixtures and the guides and latches.

The connector holding fixtures are constructed so that the connector can be pivoted into either a vertical or horizontal position. During harness assembly, the connector is positioned vertically, so that the insertion head can move down and insert the terminal. After the assembly process is complete, the connectors are pivoted into the horizontal plane of the harness. The wires are dressed and the tying can be performed.

A continuity test array can be mounted on the lower plate and attached to each connector. This array would signal if there is discontinuity in the wire being processed, or between the wire and connector. This would stop the equipment until the problem is resolved and the sequence is manually restarted.

MATERIALS

Connectors

- 2 Deutsch DBA-30-22-55PN-059 with No. 9400-22-3014 backshell
- 1 Deutsch DBA-30-22-55SN with No. 9400-22-3014 backshell
- 1 Deutsch DBA-30-16-24SN with No. 9400-16-3014 backshell
- 1 Deutsch DBA-30-16-24PN-059 with No. 9400-16-3014 backshell

Tyer

- 1 Panduit dispenser No. PADIM loaded with PLTIM cable ties

PROCEDURE

- 1 Place the tooling board on the X-Y table and bolt it in place. This board will be assembled per specified drawing number with the connector fixtures approximately positioned.
- 2 Place the connectors in the fixtures at each location. Refer to the drawing for connector identification. Pivot the fixtures to vertical position.
- 3 Add the continuity test array to the connectors (if used).
- 4 Using the insertion head, the programmed X-Y positions, and the locating tooling, locate two insertion positions on each connector to determine the final location and orientation. Clamp the connector fixture in this position.
- 5 Run the insertion program.
- 6 Perform any required manual operations.
- 7 Remove the mating connectors on the continuity test array.
- 8 Pivot the fixtures into the horizontal plane and dress the wires evenly.
- 9 Add ties per schedule (see Tying Procedure that follows)
- 10 Remove from the tooling board.

TYING OPERATION

(Supplement to Tooling Board Operation)

The tying is performed manually with a pneumatic tying unit. The ties are loaded into the dispenser in a plastic cartridge, from which they are dispensed pneumatically when the trigger on the tying head is depressed. The tying head has two triggers, the first to open and close the jaws, and the second to activate the tying operation.

With the harness dressed and in position and the tying unit loaded and ready, proceed as follows:

- 1 Open the jaws of the dispensing head.
- 2 Position the dispensing head around the wire bundle at the tying position.
- 3 Release the jaw operating trigger, so the jaw is closed around the wire bundle.
- 4 Activate the second trigger, which automatically feeds the plastic tie and makes the wrap.
- 5 Repeat Steps 1 through 4 at each tying position.

MICROPROCESSOR OPERATION

1.1 Microprocessor Operating Procedure

Insert the proper floppy discs into the slots in the microprocessor.

- a. Place Disc No. 1 (RT-11 operating system) in the left slot.
- b. Place Disc No. 2 (38-wire) or Disc No. 3 (106-wire) in the right slot.

Move the three switches on the microprocessor lower panel to the up position.

Caps: lock on (keyboard).

Power up by switching to SYSTEM ON (the black switch on the console).

- 1 Type DX. This brings up the RT11 program.
(The disc operating system executive program)

- 2 Press RETURN key.

- CRT will show "RT-11FB V02C - 02"

Executive program Revision level

- 3 CRT will show a "."

- 4 Type RU DX1: BASIC

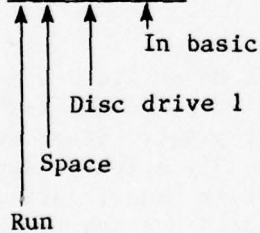

- 5 Press RETURN key.

- CRT will show "BASIC V01B - 02"
- CRT will show "*"

6 Press RETURN key.

- CRT will show "USER FNS LOADED"

Functions

- CRT will show "READY"

NOTE: At this point, BASIC is now available for a wide variety of capabilities: math, harness insertion, reel-to-reel sequencing, plot, etc.

1.2 To load the 38-wire harness insertion program, insert Disc No. 2 into the microprocessor.

7 Type OLD "DXI:CABLE 1".

8 Press RETURN key and wait for program to load.

- CRT will show "READY".

9 Type RUN.

10 Press RETURN key.

- CRT will show "COMPUTER IS LOADING PROGRAM INTO MEMORY."
- CRT will show "TYPE CORRECT PASSWORD TO ENABLE SEQUENCE TO START."

11 Type in password RUN.

12 Press RETURN key.

- CRT will show "DEPRESS 'ADVANCE' PUSHBUTTON ON INSERTER CONTROL PANEL."

CAUTION: At this point, the X-Y table must be at its 0-0 position. Do not proceed until this is done. Press in the X-Y button and the LOCAL/REMOTE button on the Unidex panel. Steer the table to clear all interferences using the joy stick located in the center of the panel below the Unidex panel. After clearing all obstacles on the table, release both buttons to the out position. Press the HOME button and the table will zero in the X direction. Push in the X-Y button and again press the HOME button to zero in the Y direction. Release the X-Y button and push in the LOCAL/REMOTE button. The readout should be 0 in both X and Y positions, and three red lights should be on, designating X OFFSET, Y OFFSET, and IN POSITION. The digital readout on the sequence control at the top of the console should be at 01. Counter should be set at 36 or higher.

13 Press ADVANCE button.

- Harness program will proceed.

NOTE: For emergency stop, press red button designated and follow repair instruction on CRT.

When ready to proceed:

14 Type GO.

15 Press RETURN key.

- CRT will show "DEPRESS ADVANCE BUTTON ON INSERTER CONTROL PANEL."

16 Press ADVANCE button.

- Harness program will proceed

To restart or get back to the executive program:

17 Press control key (CTRL) and letter key C twice.

- Wait for dot. Processor is now back to the RT-11FB executive program.

18 Start back at Step 4, or, if program is to return to where it left off before Control C was typed:

19 Type RE.

NOTE: When program reenters, the old executable program is ready to start at the beginning.

20 Press RETURN key.

21 ● CRT will show "READY". System is now back into previous program. In this case, "BASIC:" and the old "DX1:--" programs are retained. If program change to reel-to-reel is desired, go to Step 23 and type in new program as shown. Otherwise, continue.

22 Type RUN.

22A Press RETURN key.

- Previous program will start.

1.3 To load the reel-to-reel sequencer program:

- 23 Type OLD "DX1:REEL1"
- 24 Press RETURN key and wait for program to load.
 - CRT will show "READY".
- 25 Type RUN.
- 26 Press RETURN key.
 - CRT will show reel-to-reel instructions.
- 27 Follow instructions to implement program. Type in reel number, a comma, and the number of wires to be dispensed.
- 28 Press RETURN key.
- 29 Repeat steps 27 and 28 until complete sequence is registered.
- 30 To close out sequence, type in 0,0.
- 31 CRT will display which torque motor switches to turn on and which to leave off.
- 32 Switch CBI on side of reel-to-reel frame to ON position.
- 33 Per CRT, depress RUN button on console.
- 34 Type GO.

The 106-wire cable can be run by using floppy Disc No. 3 instead of Disc No. 2, and by identifying the program as OLD "DX1:CABLE1." It can be used interchangeably with the 38-wire cable program using the same tooling board. The only additional requirement is that the proper reels of wires be used in each case.

1.4 Assist Programs

Another necessary program is identified as OLD "DX1:PLOT." This program has secondary programs as follows:

- PRINT - To print out data
- MODIFY - To modify data
- SAVE - To replace data stored on disc
- NEW - To create a new file
- OLD - To recall an old file from the disc
- TABLE - To move table to X, Y coordinates
- STOP - To get out of a program loop.

From these programs, further subprograms can be called up to perform helpful side tasks. For instance, plug location subroutines can be used to position the table for connector and pin location.

When it is required that only the table move through its pattern without the insertion cycle, the proper program is OLD "DX1:TABMOV."

HARNESS ASSEMBLY OPERATION
(Insertion Head and X-Y Table)

MATERIALS

Reels - 24-inch diameter wire storage reels identified as the units making up the desired harness.

Storage Drums - Cardboard - 14-inch diameter by 19-inches high (two required for each reel).

Tooling Board - Tooling board drawing number F-40000 with the five designated connectors loaded into the holding fixtures in a vertical position and the continuity test array assembled to the connectors.

PROCEDURE

- 1 Position the tooling board on the X-Y table and bolt it in place.
- 2 Lift the torque arm and position it on the retaining pin.
- 3 Select the reel containing the first series of wires and place it on the reel shaft. Thread the red hand knob on and tighten it. Engage the drive key by pressing and turning the reel. Remove the red knob and thread on the regular hand knob. Tighten the hand knob.
- 4 Place the two empty storage drums in position under the tape dump capstans.
- 5 Unreel the tape leaders and thread them through the entry separator wheels.
- 6 The upper (hook) tape is passed upward around the capstan idler and then back down and through the drive rollers upward to the top idler wheel. The tape is passed over the two top idlers, down around the rear idler, through the rear torque motor drive wheels and into the storage drum.
- 7 The lower (loop) tape is passed over the first idler wheel, under the rear idler wheel, through the torque motor drive wheels, and into the storage drum.

- 8 Lift torque arm off of the retaining pin and push the pin in. Allow the torque arm to fall back into the reel and against the tape roll.
- 9 Power up the equipment by turning the power switch on the main console to SYSTEM.
- 10 Check that the torque motor switch on top of the electronic control box on the rear of the X-Y table cross truss is on. (Either left or right position.)

PROGRAMMING

- 1 Insert the proper floppy discs into the slots in the micro-processor.
 - a. Place Disc No. 1 (RT-11 operating system) in the left slot.
 - b. Place Disc No. 3 (106-wire) in the right slot.
- 2 Move the three switches on the microprocessor lower panel to the UP position.
- 3 Caps: lock on (keyboard).
- 4 Type DX. This brings up the RT11 program.
(The disc operating system executive program)
- 5 Press RETURN key.

● CRT will show "RT-11FB V02C - 02"

↙ Executive program ↘ Revision level

6 CRT will show a "."

7 Type RU DX1: BASIC

↑ ↑ ↑ ↑
 ↑ ↑ ↑ ↑
 Space Disc drive 1 In basic
 Run

- 8 Press RETURN key.
 - CRT will show "BASIC V01B - 02"
 - CRT will show "*"

9 Press RETURN key.

- CRT will show "USER FNS LOADED"

Functions

- CRT will show "READY"

NOTE: At this point, BASIC is now available for a wide variety of capabilities: math, harness insertion, reel-to-reel sequencing, plot, etc.

To load the 106-wire harness insertion program:

10 Type OLD "DXI:CABLE 1".

11 Press RETURN key and wait for program to load.

- CRT will show "READY".

12 Type RUN.

13 Press RETURN key.

- CRT will show "COMPUTER IS LOADING PROGRAM INTO MEMORY."
- CRT will show "TYPE CORRECT PASSWORD TO ENABLE SEQUENCE TO START."

14 Type in password RUN.

15 Press RETURN key.

- CRT will show "DEPRESS 'ADVANCE' PUSHBUTTON ON INSERTER CONTROL PANEL."

CAUTION: At this point, the X-Y table must be at its 0-0 position. Do not proceed until this is done. Press in the X-Y button and the LOCAL/REMOTE button on the Unidex panel. Steer the table to clear all interferences using the joy stick located in the center of the panel below the Unidex panel. After clearing all obstacles on the table, release both buttons to the out position. Press the HOME button and the table will zero in the X direction. Push in the X-Y button and again press the HOME button to zero in the Y direction. Release the X-Y button and push in the LOCAL/REMOTE button. The readout should be 0 in both X and Y positions, and three red lights should be on, designating X OFFSET, Y OFFSET, and IN POSITION. The digital readout on the sequence control at the top of the console should be at 01. Counter should be set at 36 or higher.

16 Press ADVANCE button.

- Harness program will proceed.

NOTE: For emergency stop, press red button designated and follow repair instruction on CRT.

17 Repair and replace wire or note position. Microprocessor will not repeat the same wire cycle after a malfunction but will go on to the next wire.

When ready to proceed:

18 Type GO.

19 Press RETURN key.

- CRT will show "DEPRESS ADVANCE BUTTON ON INSERTER CONTROL PANEL."

20 Press ADVANCE button.

- Harness program will proceed.

REEL EMPTY

When the program notes that the designated number of wires has been run off of the reel (reel empty), the operation will stop for a reel change.

- 1 Remove the remainder of the tape from the reel (this is a manual operation).
- 2 Raise the torque arm and place it on the retaining pin.
- 3 Remove the empty reel, select the next full reel in the series, and place it on the reel shaft. Put the red hand knob on and tighten it. Engage the drive key by pressing and turning the reel. Remove the red knob and put on the regular hand knob. Tighten the hand knob.
- 4 Go to Step No. 4 of the procedure, paragraph 1.2, and repeat Step No. 4 on, until the complete harness has been run.
- 5 Go to the tooling board procedure. Start at Step 8 and continue through to the end of the typing procedure.

TERMINATION PROCEDURE

- 1 Remove any tape remaining on the reel.
- 2 Raise the torque arm and place it on the retaining pin.

- 3 Remove the empty reel and the full tape drums, and return them to their proper racks.
- 4 Turn the power switch on the main console off (vertical position).

SHORT PROGRAM

A short demonstration program is available that shows all of the different possible movements required for the assembly of the harness with only 38 wires. It is contained on one harness reel.

For this program, the same RT11 system disc is inserted in the left slot of the microprocessor, and a new disc entitled Disc No. 2, short harness (38 wire) is inserted in the right slot.

The reel setup procedure is the same as above, except that the correct short cable storage reel is used.

TABLE MOVEMENT ONLY

To run the table movement only, go through Steps 1 through 9 of the programming, Paragraph 1.3, and proceed as follows:

- 10a Type OLD "DX1:TABMOV"
- 11 Same as old step 11
- 12 Same as old step 12
- 13 Same as old step 13
- 14 Same as old step 14
- 15 Same as old step 15

The TABLE MOVE program will start.

APPENDIX E

HARNESS DESIGN RECOMMENDATION HANDBOOK

HARNESS DESIGN RECOMMENDATIONS

The harness assembly equipment that has been implemented on this program is, by contract, full-sized engineering prototype equipment that is intended only to demonstrate proof of concept. It will process only one sample harness configuration and is otherwise very restrictive in capability.

The parameters that were established were intended to set up optimum conditions for demonstration of concept and not to show versatility and flexibility.

Pending the availability of additional funds, future development effort will expand the capability of the equipment to:

1. Accept a larger variety of wires.
2. Accept a larger variety of connectors and terminals.
3. Allow assembly of larger harnesses.
4. Incorporate an executive program with capability to program any harness easily.
5. Allow for insertion into connectors in a random pattern instead of row by row.

The following harness design recommendations will allow for the design of other harnesses within the restrictions set up by the program.

Wires

The wires that are recommended below have a PVC/nylon insulation and have a high degree of usage in missile system control and instrumentation harness design. They have physical characteristics that are compatible with the insertion head that has been implemented on the prototype machine.

20 gage, 22 gage, and 24 gage wire is available as follows:

20 gage - NAS-702-20-UC	.063" O.D.
20 gage - NAS-702-22-UC	.055" O.D.
24 gage - NAS-702-24-UA	.063" O.D.

Any other wires with insulation diameters within the above noted range can be used in place of those noted.

When it is necessary to use wires other than those listed above, it will be necessary to install those wires manually. They should be scheduled for installation at the top of the connector after all automated operations have been completed. These wires may consist of:

1. Twisted pairs
2. Shielded wires
3. Coaxial wires
4. Heavy power wires
5. Very small gage wire (#26 and higher).

When larger size wires are necessary, consideration should be given during the design stage to using two parallel wires to carry the load in place of one single larger gage wire, thereby avoiding a manual insertion, and staying within design parameters.

Connectors

The connector types required for use with the program concept require the following parameters:

1. The connectors must be loose pin, rear entry type.
2. The rear wafer must be a resilient material.
3. The backshell must be straight in, not 90° or 45° elbow type.
4. The connector must accept contacts compatible with the insertion head.

The connector selected for the sample harness is the Deutsch #DBA-30 series connector. It is a thread coupling, environmental type connector designed to meet industry requirements of NAS 1599. It conforms to MIL-C-26500 and is intermateable and interchangeable with any corresponding thread coupling connectors.

The accompanying chart indicates the connectors and contacts designated for the harness and also those required for the mating test array. Any other compatible connector can be substituted whether it is round or rectangular since the holding fixture adapter can be easily altered.

Contacts

The #20 size Deutsch contact is recommended. Use of any other size or type requires examination and test to determine whether automatic assembly is possible, or whether manual processing is necessary.

Termination of Wires

The crimp of the terminals on the wires is critical and must be made very carefully and properly. The wrong crimp tool or the wrong crimp setting will result in excessive barrel distortion or eccentric positioning of the wire in the barrel. Either condition will result in improper seating of the terminal in the inserter quill and malfunction or damage to the product and/or equipment. If the problem persists, a sizing operation may be required to prepare the terminals for the inserter quill.

Improper crimping could also result in undercrimp which in turn will leave the wire loose in the barrel. This condition will cause failure of the joint during the physical pull test during the insertion operation.

The strip length and depth of insertion is also important. The wire must be inserted so that it can be seen through the inspection hole in the barrel, and the insulation should be close to the end of the terminal so that there is no exposed wire that can bend or kink during processing.

CONNECTOR QUANTITY		CONNECTOR NUMBER	CONTACT				BACKSHELL	
HARNESS	TEST		PIN		SOCKET		QTY.	NO.
			QTY.	NO.	QTY.	NO.	QTY.	NO.
2		DBA-30-22-55 PN	110	0641-1-2031			6	9400-22-3014
	2	DBA-36-22-55 SN			110	100503		
1		DBA-30-22-55 SN			55	100503		
	1	DBA-36-22-55 PN	55	0641-1-2031			4	9400-16-3014
	1	DBA-30-16-24 PN	24	0641-1-2031				
	1	DBA-36-16-24 SN			24	100503		
1		DBA-30-16-24 SN			24	100503		
	1	DBA-36-16-24 PN	24	0641-1-2031				
			213	0641-1-2031	213	100503		

CHART 1. Connector and Contact List.

An alternate method of assembly can be achieved if soldered terminals are specified. The designated crimp terminals can be soldered very satisfactorily and used in the same manner as the crimped construction.

With this procedure, the terminal is clamped into jaws that cover the barrel and the inspection hole. A solder preform is dropped into the barrel and the stripped wire is inserted at the same time that the jaws are heated electrically. The jaws are then cooled and the terminal released.

General Considerations

- The harnesses must fit within a 24" x 48" working area on the tooling board. Some degree of bending is tolerated, but care must be exercised that the final straightened out harness is acceptable aesthetically

- Every effort should be made to maintain one contact size on a given harness to simplify the original processing operation and to eliminate major logistics problems if a defective wire must be repaired or replaced.

Two contact parts are required as a minimum to prepare wires with four (4) possible contact combinations:

	Leading End	Trailing End
#1	Pin	Pin
#2	Pin	Socket
#3	Socket	Socket
#4	Socket	Pin

- When a wire is spoiled during insertion, the wire is to be removed, the wire number noted, and the automatic process continued. Wire number can also be verified on the CRT. A replacement wire can be prepared while the automatic process continues, and the part manually inserted after the automatic process is complete.

When a wire is damaged in any of the preliminary stages, i.e, transfer, terminated wire reeler, or reel-to-reel-sequencer, there will be a complete stoppage while the wire is removed and discarded, a replacement fabricated, and the wire replaced in its proper position. The program must be verified at the correct setting before continuing the operation.

- Provide connectors with some unused cavities. Do not fill the connectors. Leave some spares for additional wire laying due to design changes or repair.

- Connector orientation on the tooling board is with the keyway opposite the wire run:

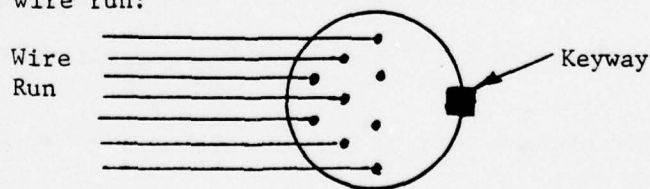

This orientation is to be observed during the design phase and for total program coordination.

- The contact insertion sequence must be rigidly maintained in order to sequence the wires into their proper positions and to allow for proper programming. The insertion sequence starts at the lower left

and proceeds to the right, with the cavities nearest the wire run being filled first, then moves to the next row up, moves to the left and thereafter alternating from the right and the left as the insertion progresses from the bottom to the top of the connector.

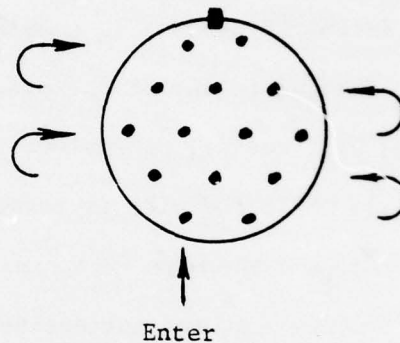

This procedure is necessary so that the holes will always be in the open for the insertion head with no wires masking the holes. The harness designer and the "Black Box" designer must learn to set up the wiring of their connectors in accordance with the requirements of automated fabrication.

If this is impossible, and random entry is required, a spreader must be developed and used on the insertion cycle to deflect wires away from the insertion line, or the wires will require manual insertion.

- Wire changes must be made on the mating "Black Box" connector, not on the harness itself due to the sequential insertion pattern from bottom to top of the connector. If this is not possible, then a manual insertion operation must be used at this point.

AD-A080 224

MARTIN MARIETTA AEROSPACE ORLANDO FL
U.S. ARMY MANUFACTURING METHODS AND TECHNOLOGY PROGRAM COVERING--ETC(U)
SEP 79 F E TARTAGLIA
DAAK40-76-C-0452
NL

JNCLASSIFIED OR-15415

2 OF 2
AD A
080224

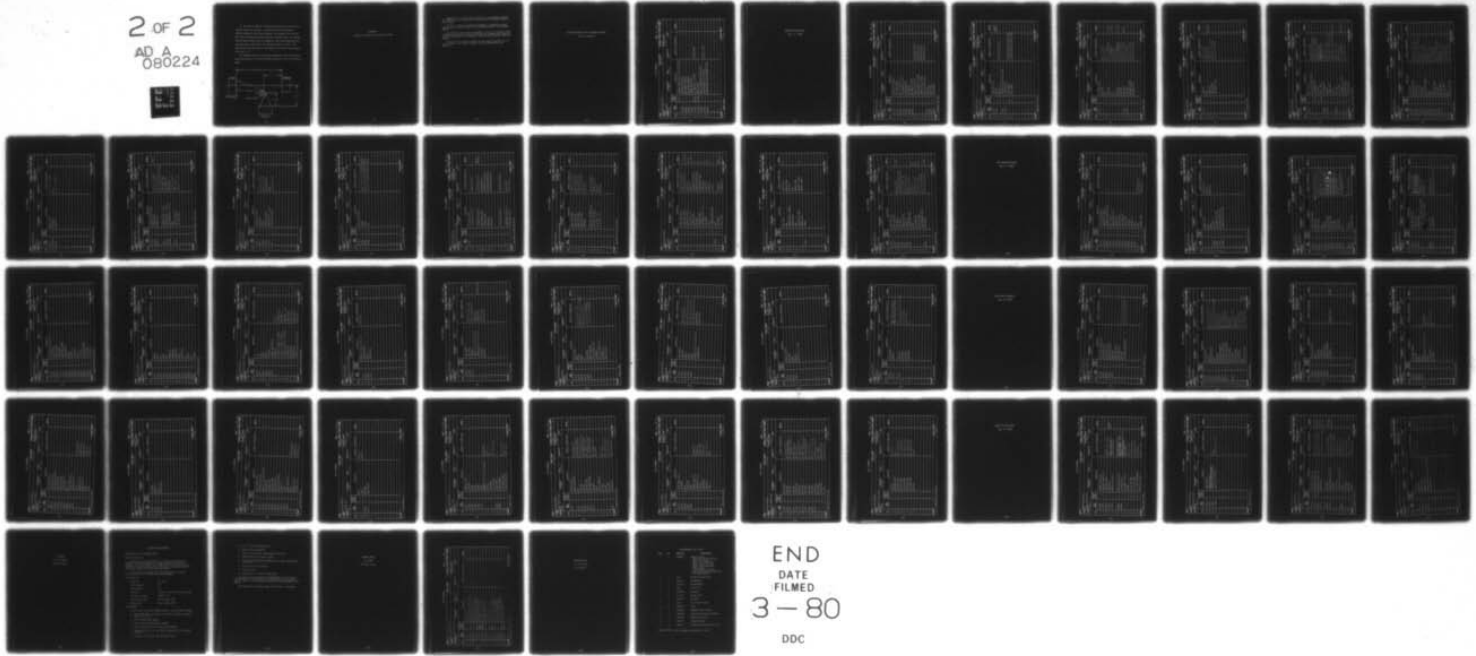

END
DATE
FILMED
3-80
DDC

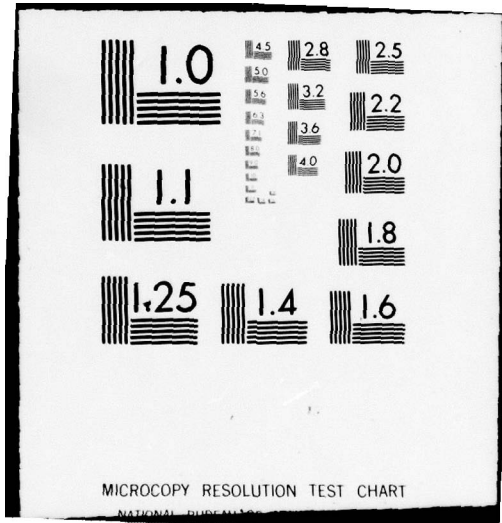

• The slack at ends of the inserted wire must be controlled and balanced equally at each end. Judicious choice of the connector position during the wire laying procedure will minimize both the wire slack and interference from the previously inserted wires. The tooling board holding fixture should be designed so that the distance from the last wire gate to the rear of the connector should be $5 \frac{3}{8}$ ". The distance down from the plane of the harness to the rear of the connector should be $2 \frac{1}{4}$ ".

The distances from the slack puller centerline to the two connector positions should be 2" in the horizontal plane and $1 \frac{3}{8}$ " in the vertical range.

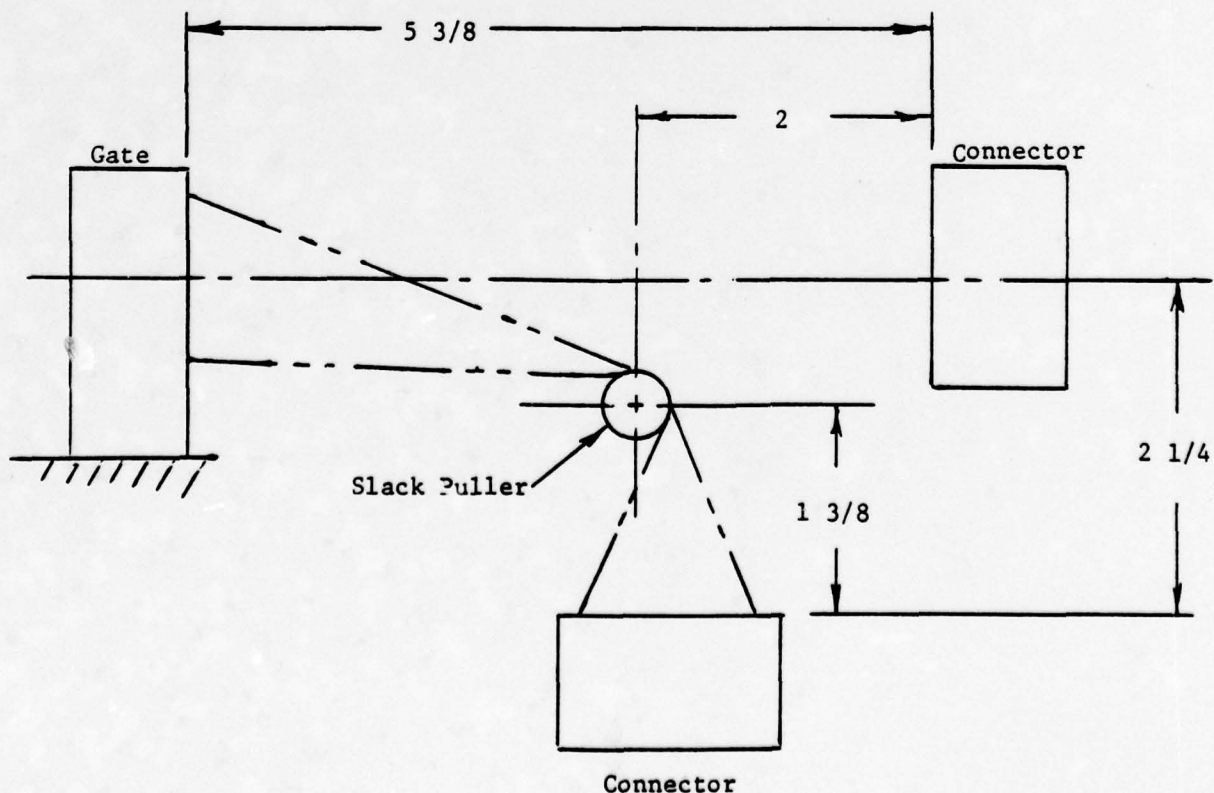

APPENDIX F

Drawings, Documentation, and Specifications

Appendix F is a complete Bill of Material of the equipment designed and fabricated for the demonstration facility under the harness mechanization program.

The Bill of Material contains the assemblies, subassemblies, detail drawings and the specifications for all purchased items for the equipment modules.

In response to contractual requirements, a full set of original formal documentation drawings and one set of prints were forwarded under separate cover on 28 February 1979 to DRDMI-EAT, MICOM, Redstone Arsenal, Huntsville, Alabama.

Drawings on the automatic harness facility general assembly, the X-Y table, and the control system assembly were not prepared under this endeavor.

AUTOMATED HARNESS FACILITY GENERAL ASSEMBLY

(Dwg not Prepared)

BILL OF MATERIAL

SHEET 1 OF 1

MODEL		MODEL NUMBER		GENERAL ASSEMBLY DRAWING NUMBER	
AUTOMATED HARNESS FACILITY		AH 200		NA	
ASSEMBLY		DEPARTMENT		DRAWING NUMBER	
GENERAL ASSEMBLY		8502 <td colspan="2">NA</td>		NA	
PREPARED BY		DATE		CHECKED BY	
F. TARTAGLIA		2-28-79			
ITEM	PART NUMBER	QUANTITY THIS ASSEMBLY	DESCRIPTION	MATERIAL OR MANUFACTURER	REMARKS
1		NO DWG	AUTOMATED HARNESS FACILITY, GENERAL ASSEMBLY		
2	F10000	1	TERMINATED WIRE REELER		
3	F20000	1	WIRE INSERTION MACHINE		
4	F30000	1	REEL-TO-REEL SEQUENCER		
5	F40000	1	HARNESS TOOLING BOARD		
6	50000	NO DWG	X-Y TABLE PER P.O. #635249	(SEE SPEC SHEET)	
7	60000	NO ASSY	CONTROL SYSTEM		
8	F70000	1	MODEL OF MECHANIZED HARNESS FACILITY		
9	80000	1	MICROPROCESSOR PER P.O. #616560	(SEE SPEC. SHEET)	
10	D90000	1	READ-ONLY-MEMORY (ROM) PROGRAMMING CHART		
ASSEMBLY GENERAL ASSEMBLY				DRAWING NUMBER NA	

TERMINATED WIRE REELER

Dwg. No. F10000

BILL OF MATERIAL

SHEET 1 OF 2

MODEL		DEPARTMENT		DATE		CHECKED BY		DATE	
TERMINATED WIRE REELER		8502		3-6-78					
MODEL		DEPARTMENT		DATE		CHECKED BY		DATE	
TERMINATED WIRE REELER		8502		3-6-78					
ASSEMBLY		DEPARTMENT		DATE		CHECKED BY		DATE	
TERMINATED WIRE REELER		8502		3-6-78					
ASSEMBLY		DEPARTMENT		DATE		CHECKED BY		DATE	
TERMINATED WIRE REELER		8502		3-6-78					
ITEM	PART NUMBER	QUANTITY THIS ASSEMBLY	DESCRIPTION	MATERIAL OR MANUFACTURER	REMARKS				
1	F10000	X	TERMINATED WIRE REELER						
2	F10100	1	TWR CONSOLE FRAME						
3	E10200	1	REEL - 24 INCH DIA.						
4	C10400	1	TWR OUTBOARD BRG. ASS'Y						
5	C10700	2	GUIDE ROLLER ASS'Y						
6	E10300	1	TWR FEED HEAD						
7	C10001	1	TWR CONSOLE TOP PLATE						
8		1	BRAKE (15 LB. IN-24V)	LEAR SIEGLER-97520-124					
9		1	GEAR HEAD MOTOR (2-10 RPM)	MINARIK-508-22-038					
10		2	SPROCKET (30T. X 2.39PD)	BOSTON GEAR HK2530-1					
11		1	CHAIN (1/4 PITCH X 23LG)	BOSTON GEAR-TYPE 25					
12	F11000	1	FRONT PANEL						
13	C10004	1	MOTOR SUPPORT						
14	B10005	2	CLUTCH SUPPORT						
ASSEMBLY TERMINATED WIRE REELER					DRAWING NUMBER				
					F10000				

BILL OF MATERIAL

SHEET 2 OF 2

MODEL		MODEL NUMBER		GENERAL ASSEMBLY DRAWING NUMBER	
TERMINATED WIRE REELER		AH 100		F10000	
ASSEMBLY		DRAWING NUMBER			
TERMINATED WIRE REELER		F10000			
PREPARED BY		DEPARTMENT	DATE	CHECKED BY	DATE
T. W. DANIELS		8502	3-6-78		
ITEM	PART NUMBER	QUANTITY THIS ASSEMBLY	DESCRIPTION	MATERIAL OR MANUFACTURER	REMARKS
15	C14000-1	1	VELCRO TAPE GUIDE		
16	B10007	1	COUPLING		SUPERSEDES C10006
17		2	BRACKET C/B	LEAR SIEGLER-97120-97120	
18	C10900	X	TWR CONTROL SYSTEM WIRING DIAGRAM		
19	C14000-2	1	VELCRO TAPE GUIDE		
20		AR	PAINT (ENAMEL)	PITTSBURGH SEMIGLOSS SANDALWOOD #22	
21		AR	PAINT (ENAMEL)	PITTSBURGH SEMIGLOSS CHESTNUT #D630	
ASSEMBLY				DRAWING NUMBER	
TERMINATED WIRE REELER				F10000	

BILL OF MATERIAL

SHEET 1 OF 2

MODEL		MODEL NUMBER		GENERAL ASSEMBLY DRAWING NUMBER	
TERMINATED WIRE REELER		AH 100		F10000	
ASSEMBLY		DEPARTMENT		DRAWING NUMBER	
TWR CONSOLE FRAME		8502		F10100	
PREPARED BY		DATE		CHECKED BY	
S. OSBORNE		4-23-76			
ITEM	PART NUMBER	QUANTITY THIS ASSEMBLY	DESCRIPTION	MATERIAL OR MANUFACTURER	REMARKS
1	F10100	X	TWR CONSOLE FRAME		
2		4	BASE PLATE	5/8 x 2 x 3 1/2 CRS	
3		6	PAD	3/8 x 2 x 3 CRS	
4		6	FRONT BRACE	3" x 43 1/2 CHANNEL-CRS	4.1 LB/FT
5		4	LEG	3" x 56 CHANNEL-CRS	4.1 LB/FT
6		3	PAD	3/8 x 3 x 3 CRS	
7		4	SIDE BRACE	3" x 18 1/4 CHANNEL-CRS	4.1 LB/FT
8		2	SIDE SHEET	16 GA x 18 1/2 x 55-CRS	
9	C10101	1	MOTOR PLATE	3/8 x 18 1/2 x 20-AL PL	6061-T6
10	C10102	1	COVER SHEET	16 GA x 20 x 50-CRS	
11		1	BACK SHEET (BOTTOM)	16 GA x 24 x 49 1/4-CRS	
12		1	BACK SHEET (TOP)	16 GA x 31 x 49 1/4-CRS	
ASSEMBLY				DRAWING NUMBER	F10100
		TWR CONSOLE FRAME			

BILL OF MATERIAL

SHEET 2 OF 2

MODEL TERMINATED WIRE REELER		MODEL NUMBER AH 100		GENERAL ASSEMBLY DRAWING NUMBER F10000	
ASSEMBLY TWR CONSOLE FRAME				DRAWING NUMBER F10100	
PREPARED BY S. OSBORNE		DEPARTMENT 8502	DATE 4-23-76	CHECKED BY	DATE
ITEM	PART NUMBER	QUANTITY THIS ASSEMBLY	DESCRIPTION	MATERIAL OR MANUFACTURER	REMARKS
13	C10103	2	TRIM SHEET	16 GA x 7 x 7-CRS	
14		2	PLATE	3/16 x 3 # 7-CRS	
15		4	FLOOR PLATE	4 DIA x 3/4-CRS	CARR-LANE
16		4	LEVELING SCREW	3/4-10 NC x 1 1/2 HEX. HD	
17		1	PLATE FRONT BOTTOM	16 GA x 24 1/4 x 50 CRS	
ASSEMBLY TWR CONSOLE FRAME				DRAWING NUMBER F10100	

BILL OF MATERIAL

SHEET 1 OF 1

MODEL		DEPARTMENT		DATE		CHECKED BY		DATE	
TERMINATED WIRE REELER		8502		8-26-77					
ASSEMBLY		QUANTITY THIS ASSEMBLY		DESCRIPTION		MATERIAL OR MANUFACTURER		REMARKS	
REEL - 24 DIA., FACE KEY DRIVE									
PREPARED BY		DEPARTMENT		DATE		CHECKED BY		DATE	
S. OSBORNE		8502		8-26-77					
ITEM	PART NUMBER	QUANTITY THIS ASSEMBLY	DESCRIPTION	MATERIAL OR MANUFACTURER	REMARKS				
1	E10200	X	REEL - 24 DIA.						
2		1	24 DIA. CAST PLASTIC FLANGE	ABS-MOSSBERG HUBBARD					
3		450 GM	POLYURETHANE FOAM	STATHANE 818-10 A = 288 GM. B = 162 GM.					
4		1	FACE COVER	FORMICA .030 x 24 1/2 SQ. SH.					
5		510 GM	EPOXY HYSOL	EPON #828 = 63 GM. VERSAMID V140 = 63 GM.					
6	B10203	1	REEL DRIVE PLATE	STEEL 6 DIA x 3/8					
7	B10201	1	REEL HUB	ALUM. 3 DIA x 1 3/4 LG.					
8		1	BUSHING, DRILL	STEEL .625 ID x .875 OD x 1.50 LG.					
9		4	SLEEVE	ALUM. TUBING .312 ID. x 7/16 OD x 1 3/4 LG.					
10	B10202	1	REEL CORE	ALUM. 6 x 6 x .750 PL					
11		4	FL. HD. SCR.	#8-32 NC x 1/2 LG.					
12		1	HAND KNOB - 2 1/2 STAR	1/2 - 13 NC THRD. (CI)	T1-11035				
13		4	CARRIAGE BOLT/NUT	1/4 - 20 NC x 3 LG.					
14	B10800	1	REEL FLANGE ASS'Y						
ASSEMBLY								DRAWING NUMBER	
								E12000	

BILL OF MATERIAL

SHEET 1 OF 2

MODEL		DEPARTMENT		DATE		MODEL NUMBER		GENERAL ASSEMBLY DRAWING NUMBER	
TERMINATED WIRE REELER		8502		2-28-78		AH 100		F10000	
ASSEMBLY		DEPARTMENT		DATE		CHECKED BY		DRAWING NUMBER	
TWR FEED HEAD		8502		2-28-78				E10300	
PREPARED BY		DEPARTMENT		DATE		CHECKED BY		DRAWING NUMBER	
T. W. DANIELS		8502		2-28-78				E10300	
ITEM	PART NUMBER	QUANTITY THIS ASSEMBLY	DESCRIPTION	MATERIAL OR MANUFACTURER	REMARKS				
1	E10300	X	TWR FEED HEAD						
2	C10305	1	FEED HEAD BASE PLATE	1/2 x 4 1/2 x 8 1/4 - CRS					
3	C10306	1	FEED HEAD GUIDE	2 1/2 x 3 x 3 - HRS (1020)					
4	C10316		F.H.B. SPACER	1/4 x 4 1/2 x 5 3/4 - CRS (LCS)					
5	B10304	1	ROLLER SHAFT	3/4 DIA x 3 LG - CRS					
6	B10315	1	ROLLER SHAFT (ECCENTRIC)	3/4 DIA x 3 LG - CRS					
7	B10319	1	ROLLER	1 5/8 DIA x 1" LG					
8	B10320	1	ROLLER	2 1/8 DIA x 1" LG					
9	1616DC	2	RADIAL BALL BEARING	NICE - BOSTON GEAR					
10	B10307	1	GUIDE EYELET	1 DIA x 1 1/2 LG HRS (1020)					
11	5101-50	2	SNAP RING (BOWED)	WALDES TRUARC - 1/2 DIA					
12		2	FL PT SET SCREW	1/4 - 20 NC x 3/4 LG					
13		2	DOWEL	.3125 DIA x 1 1/4 LG					
14		4	HEX SOC HD CAP SCREW	5/16 - 18 NC x 1 1/8 LG					
ASSEMBLY		TWR FEED HEAD		DRAWING NUMBER					
				E10300					

BILL OF MATERIAL

SHEET 2 OF 2

MODEL TERMINATED WIRE REELER		MODEL NUMBER AH 100		GENERAL ASSEMBLY DRAWING NUMBER F10000	
ASSEMBLY TWR FEED HEAD				DRAWING NUMBER E10300	
PREPARED BY T. W. DANIELS		DEPARTMENT 8502	DATE 2-28-78	CHECKED BY	DATE
ITEM	PART NUMBER	QUANTITY THIS ASSEMBLY	DESCRIPTION	MATERIAL OR MANUFACTURER	REMARKS
15	B10318	1	BRACKET, SWITCH	1 x 1 x 1/8 STR AL ANGLE	
16	311SM703-T	1	MICRO SWITCH	STYLE 19	
17	B10317	1	SWITCH COVER	3 1/2 x 3 x 24 GAGE AL	
ASSEMBLY TERMINATED WIRE REELER				DRAWING NUMBER E10300	

BILL OF MATERIAL

SHEET 1 OF 1

MODEL		MODEL NUMBER	GENERAL ASSEMBLY DRAWING NUMBER		
TERMINATED WIRE REELER		AH 100	F10000		
ASSEMBLY		DRAWING NUMBER			
OUTBOARD BEARING ASSEMBLY, FACE KEY DRIVE		C10400			
PREPARED BY		DEPARTMENT	DATE	CHECKED BY	
S. OSBORNE		8502	8-29-76		
ITEM	PART NUMBER	QUANTITY THIS ASSEMBLY	DESCRIPTION	MATERIAL OR MANUFACTURER	REMARKS
1	C10400	X	OUTBOARD BEARING ASSEMBLY		
2	C10401	1	BEARING HOUSING	4 DIA x 4 1/4 LG ALUM.	6061-T6
3	B10404	1	BEARING SHAFT	.625 DIA x 9 1/2 LG	
				GRD. S.S. SHAFT #A8-45 PIC DESIGN	
4	SC62	1	SETScrew COLLAR - 5/8 DIA	STEEL (BOSTON GEAR)	
5	1623DS	2	RADIAL BALL BRG. - 5/8 DIA	NICE (BOSTON GEAR)	
6	5100-62	1	BRG. RETAINER RING - 5/8 DIA	WALDES TRUARC	
7		1	DOWEL	.250 DIA x 1 1/2 LG	
8	B10403	1	FACE KEY DRIVE HUB	STEEL - 4 DIA x 1	
9		4	SOC HD CAP SCREW	5/16-18 NC x 1 LG	
ASSEMBLY					DRAWING NUMBER
OUTBOARD BEARING ASSEMBLY, FACE KEY DRIVE					C10400

BILL OF MATERIAL

SHEET 1 OF 1

MODEL		MODEL NUMBER		GENERAL ASSEMBLY DRAWING NUMBER	
TERMINATED WIRE REELER		AH 100		F10000	
ASSEMBLY		DEPARTMENT		DRAWING NUMBER	
GUIDE ROLLER ASSEMBLY		8502		C10700	
PREPARED BY		DATE		CHECKED BY	
S. OSBORNE		6-14-76			
ITEM	PART NUMBER	QUANTITY THIS ASSEMBLY	DESCRIPTION	MATERIAL OR MANUFACTURER	REMARKS
1	C10700	X	GUIDE ROLLER ASSEMBLY		
2	B10701	1	ROLLER SHAFT	2 DIA x 3 LG - CRS	
3	B10703	1	ROLLER	3 DIA x 1" LG - CRS	
4	1616DC	1	RADIAL BALL BEARING	NICE (BOSTON GEAR)	
5	510150	1	BOWED SNAP RING - 1/2 DIA	TRUARC	
6	STD	3	HEX SOC HD CAP SCREW	1/4-20 NC x 3/4 LG	
ASSEMBLY				DRAWING NUMBER	
GUIDE ROLLER ASSEMBLY				C10700	

BILL OF MATERIAL

SHEET 1 OF 1

MODEL REEL - 24" DIA, FACE KEY DRIVE		MODEL NUMBER AH 100	GENERAL ASSEMBLY DRAWING NUMBER E10200		
ASSEMBLY REEL FLANGE ASSEMBLY		DRAWING NUMBER B10800			
PREPARED BY T. W. DANIELS		DEPARTMENT 8502	DATE 3-7-78	CHECKED BY	
ITEM	PART NUMBER	QUANTITY THIS ASSEMBLY	DESCRIPTION	MATERIAL OR MANUFACTURER	REMARKS
1	B10800	X	REEL FLANGE ASSEMBLY		
2	B10801	1	FLANGE	1/4 x 24 1/4 x 24 1/4 SQ PLEXIGLAS	(CLEAR)
3	B10802	1	COLLAR	3/4 x 4 1/4 x 4 1/4 SQ PLEXIGLAS	(CLEAR)
4	B10803	12	RIB	3/16 x 9 x 12 PLEXIGLAS (CLEAR)	MAKES 12
ASSEMBLY REEL FLANGE ASSEMBLY				DRAWING NUMBER B10800	

MODEL		MODEL NUMBER		GENERAL ASSEMBLY DRAWING NUMBER	
TERMINATED WIRE REELER		AH 100		F10000	
ASSEMBLY		DEPARTMENT		DRAWING NUMBER	
TWR CONTROL SYSTEM WIRING DIAGRAM		8502		C10900	
PREPARED BY		DATE		CHECKED BY	
S. OSBORNE		6-28-76			
ITEM	PART NUMBER	QUANTITY THIS ASSEMBLY	DESCRIPTION	MATERIAL OR MANUFACTURER	REMARKS
1	C10900	X	TWR CONTROL SYSTEM		
M1		1	1/8 HP MOTOR (2-70 RPM)	MINARIK-502-05-038	
M3		1	CLUTCH/BRAKE (SOFTSTEP)	LEAR SIEGLER-97120-224	BRACKET 97120-1140
M1-1		1	MOTOR CONTROL SYSTEM	MINARIK-MODEL SI 52	
S1		1	PUSH/PULL SWITCH	MICROSWITCH-PTY2213B-B21	
S2		1	DPST SWITCH	MICROSWITCH-PTFBE102C-B39	
S3		1	DPST SWITCH	MICROSWITCH-PTFBE102C-B39	
S6		1	LIMIT SWITCH (STYLE 19)	MICROSWITCH-311SM703-T	
T1		1	TRANSFORMER (115V to 24V)	STANCOR-P8618	
BRI		1	DIODE BRIDGE (6 AMP)	ALLIED - VH 247	
ASSEMBLY		TWR CONTROL SYSTEM WIRING DIAGRAM		DRAWING NUMBER C10900	

BILL OF MATERIAL

SHEET 2 OF 2

MODEL		MODEL NUMBER		GENERAL ASSEMBLY DRAWING NUMBER	
TERMINATED WIRE REELER		AH 100		F10000	
ASSEMBLY		DEPARTMENT		DRAWING NUMBER	
TWR CONTROL SYSTEM WIRING DIAGRAM		8502		C10900	
PREPARED BY		DATE	CHECKED BY	DATE	
S. OSBORNE		6-28-76			
ITEM	PART NUMBER	QUANTITY THIS ASSEMBLY	DESCRIPTION	MATERIAL OR MANUFACTURER	REMARKS
L1		1	SIGNAL LIGHT (AMBER)	ALLIED-32-3101-0431-302	
L2		1	SIGNAL LIGHT (RED)	ALLIED-32-3101-0433-302	
L3		1	SIGNAL LIGHT (AMBER)	ALLIED-32-3101-0433-302	
L4		1	SIGNAL LIGHT (AMBER)	ALLIED-32-3101-0433-302	
K1		1	DPDT RELAY	ALLIED-11AY0	
R1		-	SPEED POT (1.5K) MODEL M1213	(PART OF M1-1 SYSTEM)	
K3		1	RELAY DPDT - OFF DELAY	INTERMATIC SS11822C	
R3		1	POT (50 OHM - 25 W)	MEMCOR-109	
R4		1	POT (50 OHM - 25 W)	MEMCOR-109	
ASSEMBLY				DRAWING NUMBER	C10900
TWR CONTROL SYSTEM WIRING DIAGRAM					

BILL OF MATERIAL

SHEET 1 OF 2

MODEL TERMINATED WIRE REELER ASSEMBLY FRONT PANEL		DEPARTMENT 8502	DATE 9-14-76	MODEL NUMBER AH 100	CHECKED BY	DATE	GENERAL ASSEMBLY DRAWING NUMBER F10000	DRAWING NUMBER F11000
PREPARED BY P. BARTLING	QUANTITY THIS ASSEMBLY	DESCRIPTION	MATERIAL OR MANUFACTURER	REMARKS				
1	1	SIGNAL LIGHT (RED)	ALLIED-32-3101-0431-302	L4				
2	3	SIGNAL LIGHT (AMBER)	ALLIED-32-3101-0433-302	L1, L2, L3				
3	2	DPTD RELAY (115 VAC)	ALLIED-11AYO	K1, K2				
4	2	POT (50 OHM - 25 W)	MENCOR-100	R2, R3, R4				
5	1	PUSH/PULL SWITCH	MICROSWITCH-PTY2213B-B21	S1				
6	1	DPTD SWITCH	MICROSWITCH-PTFBE102C-B38	S2				
7	1	PUSHBUTTON SWITCH	MICROSWITCH-PTP23B-B10	S3				
8	1	TRANSFORMER (115V to 24V)	STANCOR-P8618	T1				
9	1	DIODE BRIDGE	ALLIED-VH247	BR1				
10	1	PLUG A-C	HUBBELL 5266	P1				
11	A/R	3 CONDUCTOR HAZARD CORD	14 GAUGE					
12	1	PANEL						
13	3	FUSE HOLDER	BUSSMAN-HKP	FOR F1, F2, F3				
14	2	FUSE - 10 AMPS	BUSSMAN-AGC-10	F1, F2				
ASSEMBLY FRONT PANEL					DRAWING NUMBER F11000			

MODEL TERMINATED WIRE REELER		MODEL NUMBER AH 100		GENERAL ASSEMBLY DRAWING NUMBER F10000	
ASSEMBLY FRONT PANEL		DEPARTMENT 8502		DRAWING NUMBER F11000	
PREPARED BY P. BARTLING		DATE 9-14-76		CHECKED BY	
ITEM	PART NUMBER	QUANTITY THIS ASSEMBLY	DESCRIPTION	MATERIAL OR MANUFACTURER	REMARKS
15		1	FUSE-5 AMPS	BUSSMAN-AGC-5	F3
16		2	DIAL	MEMCOR-875-8030	
17		1	TERMINAL BOARD-10 TERMINAL	KULKA 600-10	
18		1	INSULATED STRIP	KULKA	
19		2	KNOB	MEMCOR-875-8060	
20		1	RELAY DPDT OFF DELAY	INTERMATIC SS11822C	K3
21		1	SOCKET 11 PIN	AMPHENOL 77-MIP12	
22	A11002	1	BRACKET		
ASSEMBLY FRONT PANEL				DRAWING NUMBER E11000	

BILL OF MATERIAL

SHEET 1 OF 1

MODEL TERMINATED WIRE REELER		MODEL NUMBER AH 100		GENERAL ASSEMBLY DRAWING NUMBER F10000	
ASSEMBLY VELCRO TAPE GUIDE		DEPARTMENT AMT		DRAWING NUMBER C14000	
PREPARED BY S. OSBORNE		DATE 11-5-77		CHECKED BY	
ITEM	PART NUMBER	QUANTITY THIS ASSEMBLY	DESCRIPTION	MATERIAL OR MANUFACTURER	REMARKS
1	C14000-1	X	VELCRO TAPE GUIDE		
2	C14000-2	X	VELCRO TAPE GUIDE		
3	B14006	1	GUIDE CHANNEL	OPTIONAL W/ITEM 2	-2 ONLY
4	C14001	1	GUIDE BRACKET	CRS 1 PC 1/4 x 1 3/4 x 2 5/8 1 PC 1/4 x 2 1/2 x 3 1/8	
5	B14005	1	PRESSURE PAD GUIDE	CRS 1" x 1 1/8 x 3 1/8	
6	B14003	1	PRESSURE PAD	TEFLON 1/2 x 3/4 x 2 3/4	
7	A14004	2	PAD ADJUSTMENT SCREW	DR ROD 1/4 x 1 1/4 LG	
8		2	JAM NUT	#10-32 NC - 2	STD.
9		1	RD HD MACH SCREW	#10-32 NC x 1 3/4 LG	STD.
10		2	HEX SOC CAP SCREW	1/4-20 NC x 1/2 LG	STD.
11		2	LIGHT COMPRESSION SPRING	.023 x 1/4 x 1" AJAX #25	
12	B14002	1	GUIDE CHANNEL	CRS 3/4 x 1 1/8 x 3 5/8	-1 ONLY
ASSEMBLY VELCRO TAPE GUIDE				DRAWING NUMBER C14000	

WIRE INSERTION MACHINE

Dwg. No. F20000

BILL OF MATERIAL

SHEET 1 OF 2

MODEL WIRE INSERTION MACHINE		MODEL NUMBER AH 200	GENERAL ASSEMBLY DRAWING NUMBER F20000	
ASSEMBLY WIRE INSERTION MACHINE			DRAWING NUMBER F20000	
PREPARED BY T. W. DANIELS		DEPARTMENT 8502	DATE 4-14-78	
		CHECKED BY	DATE	
ITEM	PART NUMBER	DESCRIPTION	MATERIAL OR MANUFACTURER	REMARKS
1	F20000	WIRE INSERTION MACHINE		
2	F20100	INSERTION HEAD ASSEMBLY		
3	F20200	DISPENSING & REVERSING ASS'Y		
4	D10200	REEL - 24" DIA		
5	C10400	OUTBOARD BEARING ASS'Y		
6	E31000	CAPSTON DRIVE		
7	E30700	PINCH ROLL DRIVE		
8	C10700	GUIDE ROLLER ASS'Y		
9	D30900	TORQUE CONTROL		
10	D20001	MAIN PLATE		
11	A10310	RETAINER PIN		
12	A10311	SLEEVE		
13		MOTOR	ELINCO #GLJRN 1015	
14		SPROCKET (35B10)	BOSTON KSA 10-1	
ASSEMBLY WIRE INSERTION MACHINE			DRAWING NUMBER F20000	

BILL OF MATERIAL

SKETCH 2 OF 2

MODEL WIRE INSERTION MACHINE		DEPARTMENT 8502	DATE 4-14-78	CHECKED BY	DATE	GENERAL ASSEMBLY DRAWING NUMBER F20000
ASSEMBLY WIRE INSERTION MACHINE			MODEL NUMBER AH 200	DRAWING NUMBER F20000		
PREPARED BY T. W. DANIELS						
ITEM	PART NUMBER	QUANTITY THIS ASSEMBLY	DESCRIPTION	MATERIAL OR MANUFACTURER	REMARKS	
15		1	SPROCKET (3540)	BOSTON KSA 40-1		
16		1	CHAIN	BOSTON #35		
17		1	COLLAR	BOSTON SC50		
18	C20002-1	1	BASE FRAME			
19	C-20006	1	SET BLOCK (SET-UP TOOL)			
20	B-20007	1	QUILL GAUGE (SET-UP TOOL)			
21	C-20008	1	ALIGNMENT TOOL (SET-UP TOOL)			
ASSEMBLY WIRE INSERTION MACHINE						DRAWING NUMBER F20000

BILL OF MATERIAL

SHEET 1 OF 2

MODEL		MODEL NUMBER		GENERAL ASSEMBLY DRAWING NUMBER	
WIRE INSERTION MACHINE		AH 200		F20000	
ASSEMBLY		DRAWING NUMBER		DRAWING NUMBER	
INSERTION HEAD ASSEMBLY		F20100		F20100	
PREPARED BY		DEPARTMENT		DATE	
F. TARTAGLIA		8502		4-5-76	
CHECKED BY		DATE		REMARKS	
ITEM	PART NUMBER	QUANTITY THIS ASSEMBLY	DESCRIPTION	MATERIAL OR MANUFACTURER	REMARKS
1	F20100	X	INSERTION HEAD ASSEMBLY		
2	B20101	1	INSERTER BODY	TOOL STEEL .500 DIA x 6.5 LG	
3	B20102	1	SEATING INSERT	TOOL STEEL .312 DIA x 8.38 LG	
4	B20123	1	COVER	AL ALLOY 6061 - T2 1/8 x 1.40 x 2.20	
5	C20104	1	SLIDE BASE	MEEHANITE .75 x 5.75 x 13.75 LG	
6	B20105	1	SLIDE SIDE SPACER	FLT HDN. GRD. STK-TOOL STEEL .312 x .38 x 13.38 LG	
7	B20106	1	SLIDE SIDE SPACER	FLT. HDN. GRD. STK-TOOL STEEL .312 x .38 x 13.38 LG	
8	B20107	1	SLIDE COVER	FLT. HDN. GRD. STK-TOOL STEEL .187 x .62 x 13.38 LG	
9	B20108	1	SLIDE COVER	FLT. HDN. GRD. STK-TOOL STEEL .187 x .62 x 13.38 LG	
10	B20109	1	SLIDE UPRIGHT	CRS .312 x 2.12 x 5.5 LG	
11	B20110	1	SLIDE	FLT. HDN. GRD. STK-TOOL STEEL .34 x 2.06 x 5.5 LG	
12					
13	A20112	1	COUPLING	CRS .56 DIA x 1.25 LG	
14	B20113	1	TIP MOUNTING BLOCK	CRS .88 x 1.44 x 2.31 LG	
ASSEMBLY INSERTION HEAD ASSEMBLY				DRAWING NUMBER F20100	

BILL OF MATERIAL

SHEET 2 OF 2

MODEL		MODEL NUMBER		GENERAL ASSEMBLY DRAWING NUMBER	
WIRE INSERTION MACHINE		AH 200		F20000	
ASSEMBLY		DEPARTMENT		DRAWING NUMBER	
INSERTION HEAD ASSEMBLY		8502 <td colspan="2">F20100</td>		F20100	
PREPARED BY		DATE		CHECKED BY	
F. TARTAGLIA		4-5-76			
ITEM	PART NUMBER	QUANTITY THIS ASSEMBLY	DESCRIPTION	MATERIAL OR MANUFACTURER	REMARKS
15	B20114	1	SLIDE MOUNTING BRACKET	CRS .69 x 1.44 x 1.44 LG	
16	B20115	1	CYLINDER BRACKET	CRS .25 x 1.75 x 3.75 LG CRS .19 x 1.75 x 1.75 LG CRS .19 x 1.62 x 2.00 LG	
17	B20116	1	CYLINDER BRACKET	CRS .25 x 2.00 x 2.62 LG CRS .19 x 1.25 x 1.62 LG	
18		1	CYLINDER - 1 1/8" BORE x 8 1/2 STROKE	MEAD #MR8N - 8 1/2"	
19		1	CYLINDER - 1/2" BORE x 1" STROKE	MEAN #MR2N - 1"	
20					
21	B20118	1	SEATING QUILL	#37 DRILL ROD 2.50 LG	
22	B20119	2	INSERT RETAINER	TOOL STEEL .000 x .204 x 3 1/2 LG	
ASSEMBLY INSERTION HEAD ASSEMBLY				DRAWING NUMBER F20100	

BILL OF MATERIAL

SHEET 1 OF 4

MODEL		MODEL NUMBER		GENERAL ASSEMBLY DRAWING NUMBER	
WIRE INSERTION MACHINE		AH 200		F20000	
ASSEMBLY					
DISPENSING AND REVERSING ASSEMBLY					
PREPARED BY		DEPARTMENT	DATE	CHECKED BY	DATE
T. W. DANIELS		8502	4-6-78		
ITEM	PART NUMBER	QUANTITY THIS ASSEMBLY	DESCRIPTION	MATERIAL OR MANUFACTURER	REMARKS
1	F20200	X	DISPENSING AND REVERSING ASS'Y		
2	B20300	1	BASE ASSEMBLY		
3	B20400	1	THIMBLE ASSEMBLY		
4	D20500	1	GUIDE ASSEMBLY		
5	B 30300	1	IDLER WHEEL ASSEMBLY		
6	D20700	1	SHELF ASSEMBLY		
7	C20201	1	SPACER		
8	B20202	1	BRACKET		
9	B20203-1	1	PIVOT STAND		
10	A20204	1	ROD END		
11	A20205	1	ROD END		
12	B20206	1	WIRE RELEASE CRANK		
13	B20207	1	PRESS CRANK		
14	B20203-2	1	PIVOT STAND		
ASSEMBLY					DRAWING NUMBER
DISPENSING AND REVERSING ASSEMBLY					F20200

BILL OF MATERIAL

SHEET 2 OF 4

MODEL		MODEL NUMBER		GENERAL ASSEMBLY DRAWING NUMBER	
WIRE INSERTION MACHINE		AH 200		F20000	
ASSEMBLY		DEPARTMENT		DRAWING NUMBER	
DISPENSING AND REVERSING ASSEMBLY		8502		F20200	
PREPARED BY		DATE		CHECKED BY	
T. W. DANIELS		4-6-78			
ITEM	PART NUMBER	QUANTITY THIS ASSEMBLY	DESCRIPTION	MATERIAL OR MANUFACTURER	REMARKS
15	B20208	1	BRACKET		
16	A20209	1	CLEVIS		
17	A20210	3	PIN		
18	A20211	6	WASHER		
19	A20212	1	RACK		
20	B20213	1	PRESSURE PAD		
21	B20214	1	SPACER BLOCK		
22	A20215	1	REVERSING ARM		
23	A20216	1	PINION		
24	A20217	1	BEARING PLATE		
25	A20218	2	PIN		
26	A20219	1	COLLAR		
27	A20220	1	PAD		
28	A20221	1	PUSH ROD		
ASSEMBLY				DRAWING NUMBER	
DISPENSING AND REVERSING				F20200	

BILL OF MATERIAL

MODEL		MODEL NUMBER		GENERAL ASSEMBLY DRAWING NUMBER	
WIRE INSERTION MACHINE		AH 200		F20000	
ASSEMBLY					
DISPENSING AND REVERSING ASSEMBLY					
PREPARED BY		DEPARTMENT	DATE	CHECKED BY	DATE
T. W. DANIELS		8502	4-6-78		
ITEM	PART NUMBER	QUANTITY THIS ASSEMBLY	DESCRIPTION	MATERIAL OR MANUFACTURER	REMARKS
29	A20222	1	CAP		
30	A20223	1	PIN		
31	A20226	2	WASHER		
32	A20236	2	WASHER		
33	B20230	1	WIRE GUIDE		
34	D20239	1	BRACKET, OPTICAL SWITCH		
35		1	MICROSWITCH	STYLE 19	
36		2	CYLINDER 1/2" BORE x 1 1/2" STROKE	MEAD #MR2N - 1/2"	
37		1	CYLINDER 1/2" BORE x 1" STROKE	MEAD #MR2N - 1"	
38		1	CYLINDER 1/2" BORE x 1 1/2" STROKE	MEAD #MR2N - 1 1/2"	
39		2	RETAINING RING	WALDES #5100-31	
40		6	RETAINING RING	WALDES #5100-15	
41		2	RETAINING RING	WALDES #5100-12	
42		1	BEARING 5/16 ID x 3/8 OD x 7/8 LG	BOSTON #B56-7	ALTER
ASSEMBLY				DRAWING NUMBER	
DISPENSING AND REVERSING ASSEMBLY				F20200	

BILL OF MATERIAL

MODEL WIRE INSERTION MACHINE		MODEL NUMBER AH 200		GENERAL ASSEMBLY DRAWING NUMBER F20000	
ASSEMBLY BASE ASSEMBLY		DEPARTMENT 8502		DRAWING NUMBER B20300	
PREPARED BY F. TARTAGLIA		DATE 5-12-76		CHECKED BY	
ITEM	PART NUMBER	QUANTITY THIS ASSEMBLY	DESCRIPTION	MATERIAL OR MANUFACTURER	REMARKS
1	B20300	X	BASE ASSEMBLY		
2	B20301	1	BASE BLOCK	CRS .94 x 1.88 x 2.12 LG	
3	B20302	1	BASE BLOCK	CRS .75 x 1.88 x 2.12 LG	
4		2	BEARING 1/4 ID x 3/8 OD x .25 LG	BOSTON #B-46-2	
5		2	BEARING 3/8 ID x 1/2 OD x .25 LG	BOSTON #B-68-3	ALTER TO .25LG
6		4	SOC CAP SCR	#10-32 x 1.0 LG	
7		2	DOWEL PIN	1/8 DIA x .75 LG	
8					
ASSEMBLY BASE ASSEMBLY				DRAWING NUMBER B20300	

BILL OF MATERIAL

SHEET 1 OF 1

MODEL		MODEL NUMBER		GENERAL ASSEMBLY DRAWING NUMBER	
WIRE INSERTION MACHINE		AH 200		F20000	
ASSEMBLY		DRAWING NUMBER			
THIMBLE ASSEMBLY		B20400			
PREPARED BY		DEPARTMENT	DATE	CHECKED BY	DATE
F. TARTAGLIA		8502	5-12-76		
ITEM	PART NUMBER	QUANTITY THIS ASSEMBLY	DESCRIPTION	MATERIAL OR MANUFACTURER	REMARKS
1	B20400	X	THIMBLE ASSEMBLY		
2	A20401	1	THIMBLE	ST. ST. 1.250 DIA x .90 LG	
3	B20402	1	BRACKET	STEEL ANGLE 1/4 x 2.0 x 2.0 x 1.88 LG	
4	A20403	1	CAP	CRS .250 x 1.00 x 1.88 LG	
5	A20404	1	WIRE RETAINER	1 1/4 x 1/2 x 1/4 HARD RUBBER	
6	A20405	1	BRACKET, BRAKE-AWAY	1 3/4 x 1 3/4 x .10 FIBERGLASS	
7		2	#6-32 SC HD SCREW .88 LG		
8		2	LOCK WASHER #6		
9		3	#10-32 SC HD SCREW .50 LG		
10		3	LOCK WASHER #10		
11		2	SPACER .10 THICK		
ASSEMBLY THIMBLE ASSEMBLY				DRAWING NUMBER	820400

BILL OF MATERIAL

MODEL		MODEL NUMBER		GENERAL ASSEMBLY DRAWING NUMBER	
WIRE INSERTION MACHINE		AH 200		F20000	
ASSEMBLY		DEPARTMENT		DRAWING NUMBER	
GUIDE ASSEMBLY		8502 <td colspan="2">C20500</td>		C20500	
PREPARED BY		DATE		CHECKED BY	
T. W. DANIELS		2-27-78			
ITEM	PART NUMBER	QUANTITY THIS ASSEMBLY	DESCRIPTION	MATERIAL OR MANUFACTURER	REMARKS
1	C20500	X	GUIDE ASSEMBLY		
2	B20501	1	GUIDE BASE	CRS .31 x 3.12 DIA CRS .75 DIA x 2.44 LG	
3	A20502	2	SPACER	FLT. GRD. STK .050 TH x 1.12 DIA	
4	A20503	1	WASHER	FLT. GRD. STK .030 x 1.12 DIA	
5	B20504	1	ROLLER	FLT. GRD. STK .875 TH x 4.12 DIA	
6		2	BEARING 1/2 ID X 1 1/8 OD X 3/8 TH	BOSTON #1616DC	
7		1	RETAINING RING	WALDES #5100-50	
ASSEMBLY GUIDE ASSEMBLY				DRAWING NUMBER D20500	

BILL OF MATERIAL

MODEL WIRE INSERTION MACHINE			MODEL NUMBER AH 200		GENERAL ASSEMBLY DRAWING NUMBER F20000	
ASSEMBLY SWING ARM ASSEMBLY			DRAWING NUMBER B20600			
PREPARED BY T. W. DANIELS		DEPARTMENT 8502	DATE 4-12-78	CHECKED BY	DATE	
ITEM	PART NUMBER	QUANTITY THIS ASSEMBLY	DESCRIPTION	MATERIAL OR MANUFACTURER	REMARKS	
1	B20600	X	SWING ARM ASSEMBLY			
2	A20601	1	DRIVE FORK			
3	A20602	1	SPACER			
4	A20603	1	SWING ARM			
5		1	SHAFT 1/16 X 1" LG (CRS)			
ASSEMBLY				DRAWING NUMBER		B20600
SWING ARM ASSEMBLY						

BILL OF MATERIAL

SHEET 1 OF 1

MODEL WIRE INSERTION MACHINE		MODEL NUMBER AH 200		GENERAL ASSEMBLY DRAWING NUMBER F20000	
ASSEMBLY SHELF ASSEMBLY				DRAWING NUMBER D20700	
PREPARED BY F. TARTAGLIA		DEPARTMENT 8502	DATE 5-12-76	CHECKED BY	DATE
ITEM	PART NUMBER	QUANTITY THIS ASSEMBLY	DESCRIPTION	MATERIAL OR MANUFACTURER	REMARKS
1	D20700	X	SHELF ASSEMBLY		
2	D20701	1	PLATFORM	CRS (1) .250 x 6.00 x 10.62 LG CRS (1) .250 x 1.25 x 10.62 LG CRS (3) .250 x 1.25 x 5.75 LG	
3	D20702	1	BACK PLATE	FLT. GRD. STK .250 x 9.00 x 10.62	LG
4		4	SOC CAP SCR	1/4 - 20 x .56 LG	
5		4	SOC CAP SCR	#8 - 32 x .50 LG	
6		4	LOCK WASHER	1/4	
ASSEMBLY SHELF ASSEMBLY				DRAWING NUMBER D20700	

REEL-TO-REEL SEQUENCER

Dwg. No. F30000

BILL OF MATERIAL

SHEET 1 OF 1

MODEL REEL TO REEL SEQUENCER ASS'Y		MODEL NUMBER AH 300		GENERAL ASSEMBLY DRAWING NUMBER F30000	
ASSEMBLY REEL TO REEL SEQUENCER ASS'Y				DRAWING NUMBER	
PREPARED BY T. W. DANIELS		DEPARTMENT 8502	DATE 3-30-78	CHECKED BY	DATE
ITEM	PART NUMBER	QUANTITY THIS ASSEMBLY	DESCRIPTION	MATERIAL OR MANUFACTURER	REMARKS
1	F30000	X	REEL TO REEL SEQUENCER ASS'Y		
2	F30500	3	WIRE DISPENSER ASS'Y		
3	F30400	1	WIRE RECEIVER ASS'Y		
4	F30001	1	SEQUENCER MAIN FRAME		
5	C30002	1	FRONT PANEL		
6		2	UPPER SHELF PLATE		
7		1	LOWER SHELF PLATE		
8		2	SIDE COVER	2'-5 1/2" x 2'-6" x 18 GA (CRS)	
9		1	SIDE VENT (EXPANDED METAL)	2'-5 1/2" x 2'-6" x 1/4 NO. 18	
ASSEMBLY REEL TO REEL SEQUENCER ASS'Y				DRAWING NUMBER	F30000

BILL OF MATERIAL

SHEET 1 OF 1

MODEL		DEPARTMENT		DATE		CHECKED BY		DATE	
REEL TO REEL SEQUENCER		8502		11-2-77					
ASSEMBLY									
WIRE RECEIVER HEAD									
PREPARED BY									
S. OSBORNE									
								MODEL NUMBER	
								AH 300	
								GENERAL ASSEMBLY DRAWING NUMBER	
								F30000	
								DRAWING NUMBER	
								E30100	
ITEM	PART NUMBER	QUANTITY THIS ASSEMBLY	DESCRIPTION	MATERIAL OR MANUFACTURER	REMARKS				
1	E30100	X	WIRE RECEIVER HEAD						
2	C30103	1	BASE PLATE	CRS 1/2 x 4 1/2 x 8 1/4 LG					
3	C30101	1	RECEIVER HEAD GUIDE	CRS 2 x 2 1/2 x 3 LG					
4	B30104	1	SPACER	FL GR STK .218 x 4 3/8 x 6 LG (STEEL)					
5	B10304	1	ROLLER SHAFT	CRS 7/8 DIA x 3 LG					
6	B10315	1	ROLLER SHAFT (ECCENTRIC)	CRS 7/8 DIA x 3 LG					
7	B10319	1	GUIDE ROLLER (VELCRO LOOP)	CRS 1 5/8 DIA x 1" LG					
8	B10320	1	GUIDE ROLLER (VELCRO HOOK)	CRS 2 1/8 DIA x 1" LG					
9		2	RADIAL BALL BEARING	NICE 1616 DC					
10	A30102	1	GUIDE EYELET	CRS 7/8 DIA x 1 1/2 LG					
11		2	SNAP RING (BOWED)	WALDES 5101-50					
12		2	FL PT SET SCREW	1/4 - 20 NC x 3/4 LG					
13		2	DOWEL	.3125 DIA x 1 1/4 LG	STD				
14		4	HEX SOC HD CAP SCREW	5/16 - 18 NC x 1 1/8 LG	STD				
ASSEMBLY		WIRE RECEIVER HEAD		DRAWING NUMBER					
				E30800					

BILL OF MATERIAL

SHEET 1 OF 1

MODEL REEL TO REEL SEQUENCER		MODEL NUMBER AH 300	GENERAL ASSEMBLY DRAWING NUMBER F30000		
ASSEMBLY WIRE FEED HEAD ASSEMBLY		DRAWING NUMBER D30200			
PREPARED BY T. W. DANIELS		DEPARTMENT 8502	DATE 3-22-78	CHECKED BY	
ITEM	PART NUMBER	QUANTITY THIS ASSEMBLY	DESCRIPTION	MATERIAL OR MANUFACTURER	REMARKS
1	D30200	X	WIRE FEED HEAD ASS'Y		
2	D30201	1	BASE		
3	C30202	1	WIRE GUIDE		
4	A30203	1	GUIDE BASE		
5	B30300	1	IDLER WHEEL ASS'Y		
6	D30205	1	BRACKET, MICROSWITCH		
7		1	MICROSWITCH	HONEYWELL 311SM3-T	ALTERED
ASSEMBLY WIRE FEED HEAD ASS'Y					DRAWING NUMBER D30200

BILL OF MATERIAL

SHEET 1 OF 1

MODEL REEL TO REEL SEQUENCER		DEPARTMENT 8502		DATE 3-22-78	MODEL NUMBER AH 300	GENERAL ASSEMBLY DRAWING NUMBER F30000
ASSEMBLY IDLER WHEEL ASSEMBLY		CHECKED BY		DATE	DRAWING NUMBER B30300	
PREPARED BY T. W. DANIELS		DESCRIPTION		MATERIAL OR MANUFACTURER	REMARKS	
ITEM	PART NUMBER	QUANTITY THIS ASSEMBLY				
1	B30300	X	IDLER WHEEL ASSEMBLY			
2	C30301	1	IDLER BASE			
3	A30302	4	SPACER			
4	A30303	2	ROLLER			
5		2	BEARING 3/8 ID X 7/8 OD X 1 1/32 WIDE	BOSTON #1604DC		
6		2	JAM NUT	3/8 - 24		
7		4	SC HD CAP SCREW	#10 - 32 x 1 3/4 LG		
8		4	LOCK WASHER	#10		
ASSEMBLY IDLER WHEEL ASSEMBLY					DRAWING NUMBER B30300	

BILL OF MATERIAL

SHEET 1 OF 2

MODEL		MODEL NUMBER		GENERAL ASSEMBLY DRAWING NUMBER	
REEL TO REEL SEQUENCER		AH 300		F30000	
ASSEMBLY		DEPARTMENT		DRAWING NUMBER	
WIRE RECEIVER ASSEMBLY		8502		F30400	
PREPARED BY		DATE	CHECKED BY	DATE	
T. W. DANIELS		3-27-78			
ITEM	PART NUMBER	QUANTITY THIS ASSEMBLY	DESCRIPTION	MATERIAL OR MANUFACTURER	REMARKS
1	F30400	X	WIRE RECEIVER ASS'Y		
2	D30401	1	RECEIVER FACE PLATE		
3	E30100	1	WIRE RECEIVER HEAD ASS'Y		
4	E30700	1	PINCH ROLL DRIVE		
5	C14000-1	2	VELCRO TAPE GUIDE		
6	C10700	1	GUIDE ROLLER ASS'Y		
7	E10200	1	REEL - 24"		
8	D30900	1	TORQUE CONTROL ASS'Y		
9	C10400	1	OUTBOARD BRG. ASS'Y		
10		1	MOTOR	ELINCO #GLJRN1015	
11		1	SPROCKET (35 B10)	BOSTON KSA 10-1	
12		1	SPROCKET (35 40)	BOSTON KSA 40-1	
13		1	CHAIN	BOSTON #35	
14		1	COLLAR	BOSTON SC50	
ASSEMBLY WIRE RECEIVER ASSEMBLY				DRAWING NUMBER	
				F30400	

BILL OF MATERIAL

MODEL		MODEL NUMBER		GENERAL ASSEMBLY DRAWING NUMBER	
REEL TO REEL SEQUENCER		AH 300		F30000	
ASSEMBLY				DRAWING NUMBER	
WIRE RECEIVER ASSEMBLY				F30400	
PREPARED BY		DEPARTMENT	DATE	CHECKED BY	DATE
T. W. DANIELS		8502	3-27-78		
ITEM	PART NUMBER	QUANTITY THIS ASSEMBLY	DESCRIPTION	MATERIAL OR MANUFACTURER	REMARKS
15	C20002-1	1	BASE FRAME		
16	A10310	1	RETAINER PIN		
17	A10311	1	SLEEVE		
18	E30402	1	RECEIVER FRAME		
ASSEMBLY	WIRE RECEIVER ASSEMBLY			DRAWING NUMBER	F30400

BILL OF MATERIAL

SHEET 1 OF 2

MODEL		MODEL NUMBER		GENERAL ASSEMBLY DRAWING NUMBER	
REEL TO REEL SEQUENCER		AH 300		F 30000	
ASSEMBLY		DEPARTMENT		DRAWING NUMBER	
WIRE DISPENSER ASS'Y		8502		F 30500	
PREPARED BY		DATE	CHECKED BY	DATE	
T. W. DANIELS		3-16-78			
ITEM	PART NUMBER	QUANTITY THIS ASSEMBLY	DESCRIPTION	MATERIAL OR MANUFACTURER	REMARKS
1	F 30500	X	WIRE DISPENSER ASS'Y		
2	Ds0501	1	DISPENSER FACE PLATE		
3	E10200	1	REEL (24" DIA) FACE KEY DRIVE		
4	D30200	1	WIRE FEED HEAD		
5	E31000	1	CAPSTAIN DRIVE		
6	E30700	1	PINCH ROLL DRIVE		
7	C10700	4	GUIDE ROLLER ASS'Y		
8	C10400	1	WIRE REEL BRG HOUSING		
9	A10310	1	RETAINER PIN		
10	A10311	1	SLEEVE		
11	D30900	1	TORQUE CONTROL ASS'Y		
12		1	MOTOR	ELINCO #GLJRN 1015	
13		1	SPROCKET (35 B10)	BOSTON KSA 10-1	
14		1	SPROCKET (35 40)	BOSTON KSA 40-1	
ASSEMBLY				DRAWING NUMBER	
WIRE DISPENSER ASSEMBLY				F 30500	

BILL OF MATERIAL

SHEET 2 OF 2

MODEL REEL TO REEL SEQUENCER		MODEL NUMBER AH 300		GENERAL ASSEMBLY DRAWING NUMBER F30000	
ASSEMBLY WIRE DISPENSER ASS'Y				DRAWING NUMBER F30500	
PREPARED BY T. W. DANIELS		DEPARTMENT 8502	DATE 3-16-78	CHECKED BY	DATE
ITEM	PART NUMBER	QUANTITY THIS ASSEMBLY	DESCRIPTION	MATERIAL OR MANUFACTURER	REMARKS
15		1	CHAIN	BOSTON #35	
16		1	COLLAR	BOSTON SC50	
17	C20002-1	1	BASE FRAME		
18	C30600	1	VELCRO CONVEYOR		
ASSEMBLY WIRE DISPENSER ASS'Y				DRAWING NUMBER F30500	

BILL OF MATERIAL

SHEET 1 OF 1

MODEL		MODEL NUMBER	GENERAL ASSEMBLY DRAWING NUMBER		
REEL TO REEL SEQUENCER		AH 300	F30000		
ASSEMBLY		DRAWING NUMBER			
CONVEYOR, VELCRO		C30600			
PREPARED BY		DEPARTMENT	DATE	CHECKED BY	
T. W. DANIELS		8502	7-21-78		
ITEM	PART NUMBER	QUANTITY THIS ASSEMBLY	DESCRIPTION	MATERIAL OR MANUFACTURER	REMARKS
1	C30600	X	CONVEYOR, VELCRO		
2	B30601	1	IDLER BASE		
3	A30602	1	ROLLER		
4	A30603	1	SPACER		
5	B30604	1	SUPPORT		
6	A30302	2	SPACER		
7		1	BEARING 3/8 ID X 7/8 OD X 11/32 WIDE	BOSTON #1604DC	
8		1	JAM NUT	3/8 - 24	
9		1	LOCK WASHER	3/8	
10		3	SC HD CAP SCREW	10 - 32 x 1 1/2 LG	
11	B30605	1	GUIDE, CHANNEL		
12	B30606	1	SUPPORT, CHANNEL		
13		2	RD HD MACHINE SCREW	10 - 24 x 3/8 LG	
14		3	RIVET, UNIVERSAL HEAD	3/32 x 1/4 LG	
ASSEMBLY				DRAWING NUMBER	
CONVEYOR, VELCRO				C30600	

BILL OF MATERIAL

SHEET 1 OF 1

MODEL		DEPARTMENT		DATE		CHECKED BY		DATE	
REEL TO REEL SEQUENCER ASSEMBLY		8502		10-27-77					
PINCH ROLL DRIVE (VELCRO)									
PREPARED BY									
S. OSBORNE									
ITEM	PART NUMBER	QUANTITY THIS ASSEMBLY	DESCRIPTION	MATERIAL OR MANUFACTURER	REMARKS				
1	E30700	X	PINCH ROLL DRIVE						
2		1	ELINCOS TORQUE MOTOR	ELINCO GLJRJD 1015					
3	C21402	1	BASE	1 PC 1/4 x 4 3/4 x 5 2 PC 1/4 x 1 1/8 x 5					
4	B21404	1	PIVOT BASE	CRS 1/4 x 1 3/4 x 4 1/2					
5	B21406	1	PIVOT ARM	1 PC 5/8 x 1 3/4 x 3 1/2 1 PC 1/2 x 1 3/4 x 2					
6	B30701	1	PINCH ROLL SHAFT	CRS 1 1/8 DIA x 3 1/2 LG					
7	C30702	1	DRIVE WHEEL (VELCRO)	2 PC 16 GA x 4 1/2 SQ 1 PC 3/4 x 4 1/4 SQ					
8	B21312	1	IDLER WHEEL	CRS 1 3/8 DIA x 1.0 LG					
9		1	BEARING	NICE #1603DS					
10			SPRING, COMPRESSION						
11		1	NUT, WING	#10 - 32 NC					
12		1	EYE BOLT	#10 - 32 NC x 3 1/2 LG					
13		1	DOWEL SHAFT	.3125 DIA x 1 1/4 GL					
14	A21405	1	EYE BOLT BASE	CRS 5/8 SQ x 1 1/4 LG					
ASSEMBLY									
PINCH ROLL DRIVE (VELCRO)				DRAWING NUMBER E30700					

BILL OF MATERIAL

SHEET 1 OF 1

MODEL REEL TO REEL SEQUENCER		MODEL NUMBER AH 300		GENERAL ASSEMBLY DRAWING NUMBER F30000	
ASSEMBLY TORQUE CONTROL ASSEMBLY			DRAWING NUMBER D30900		
PREPARED BY T. W. DANIELS		DEPARTMENT 8502	DATE 3-23-78	CHECKED BY	DATE
ITEM	PART NUMBER	QUANTITY THIS ASSEMBLY	DESCRIPTION	MATERIAL OR MANUFACTURER	REMARKS
1	D30900	X	TORQUE CONTROL ASS'Y		
2	B30901	1	POT BRACKET		
3	B30902	1	SHAFT		
4	B30903	1	CONTROL ARM		
5	B30904	1	SLEEVE		
6		1	SPROCKET 100T 40 DP	PLASTOCK INC	
7		1	SPROCKET 24T 40 DP	PLASTOCK INC	
8		1	NYLON BELT	SDP A626-162025	
9		1	POTENTIOMETER	MINARIK M-1213	
10		1	SPRING ARM	3/16 x 1/2 x 5 LG	
11		1	SPRING	DS-221	
ASSEMBLY TORQUE CONTROL ASSEMBLY				DRAWING NUMBER D30900	

BILL OF MATERIAL

SHEET 1 OF 2

MODEL		MODEL NUMBER		GENERAL ASSEMBLY DRAWING NUMBER	
REEL TO REEL SEQUENCER		AH 300		F30000	
ASSEMBLY		DEPARTMENT		DRAWING NUMBER	
CAPSTAN DRIVE (VELCRO TAPE)		8502		E31000	
PREPARED BY		DATE		CHECKED BY	
S. OSBORNE		11-11-77			
ITEM	PART NUMBER	QUANTITY THIS ASSEMBLY	DESCRIPTION	MATERIAL OR MANUFACTURER	REMARKS
1	E31000	X	CAPSTAN DRIVE		
2	C21308	1	MOTOR BASE	1 PC 1/4 x 5 x 5 CRS 2 PC 1/4 x 1 1/8 x 5	
3	B21305	1	PIVOT BASE	1 PC .312 x 2 1/4 x 5 LG CRS 1 PC .562 x 1 3/8 LG	
4	B21311	1	PIVOT ARM	1 x 2 x 4 CRS 1/4 x 1 3/4 x 2	
5	A21304	1	EYE BOLT BASE	CRS 3/4 x 1 1/4 x 2	
6	B21310	1	IDLER BASE	CRS .312 x 1.0 x 3.0 LG .375 x 1.5 LG	
7	B21313	1	UPPER IDLER	STN STEEL 1 5/8 D x 1 1/4 LG	
8	B21309	1	DRIVE WHEEL	STN STEEL .06 x 2 DIA 1 3/8 x 1 3/8 LG	
9	B21312	1	IDLER WHEEL	CRS 1 3/8 x 1.0 LG	
10	B21314	1	PIVOT BASE	CRS 1 1/8 x 1 1/2 x 2 1/8	
11	B21315	1	RELEASE ARM	FL GR STK 1/4 x 2 1/2 x 5	
12		4	NICE BEARING	CAT NO. 1604DS	
13		1	STEPPING MOTOR	SUPERIOR #MO-93-FC11	
14		1	EYE BOLT	#10 - 32 NC x 3" LG	
ASSEMBLY				DRAWING NUMBER	
CAPSTAN DRIVE (VELCRO TAPE)				E31000	

BILL OF MATERIAL

MODEL		MODEL NUMBER		GENERAL ASSEMBLY DRAWING NUMBER	
REEL TO REEL SEQUENCER		AH 300		F30000	
ASSEMBLY		DEPARTMENT		DRAWING NUMBER	
CAPSTAN DRIVE (VELCRO TAPE)		8502		E31000	
PREPARED BY		DATE	CHECKED BY	DATE	
S. OSBORNE		11-14-77			
ITEM	PART NUMBER	QUANTITY THIS ASSEMBLY	DESCRIPTION	MATERIAL OR MANUFACTURER	REMARKS
15		1	WING NUT	#10 - 32 NC	
16		1	COMPRESSION SPRING	AJAX	
17		4	FLAT HEAD SCREW	#8 - 32 NC x 1/2 LG	
18		4	SOC HD CAP SCREW	1/4 - 20 NC x 3/4 LG	
19		4	SOC HD CAP SCREW	#10 - 32 NC x 1/2 LG	
20		1	SOC HD SET SCREW	1/4 - 20 NC x 1/2 LG	
21		4	SOC HD CAP SCREW	#10 - 32 NC x 1/2 LG	
22		2	SNAP RING	5/16 DIA	
ASSEMBLY				DRAWING NUMBER	
CAPSTAN DRIVE (VELCRO TAPE)				E31000	

HARNESS TOOLING BOARD

Dwg. No. F40000

BILL OF MATERIAL

SHEET 1 OF 2

MODEL		MODEL NUMBER		GENERAL ASSEMBLY DRAWING NUMBER	
HARNESSTOOLING BOARD		AH 400		F40000	
ASSEMBLY		DEPARTMENT		DRAWING NUMBER	
HARNESSTOOLING BOARD		8502		F40000	
PREPARED BY		DATE	CHECKED BY	DATE	
S. OSBORNE		9-13-76			
ITEM	PART NUMBER	QUANTITY THIS ASSEMBLY	DESCRIPTION	MATERIAL OR MANUFACTURER	REMARKS
1	F40000	X	HARNESSTOOLING BOARD		
2	F40100	5	RECEPTACLE LOCATING JIG		
3	C40010-1	27	WIRE GUIDE (MODEL A)	ALUMINUM - 3/4 x 2 1/2 x 3	ALTERNATE FIR
4	C40002	6	SPACER BLOCK	MAPLE - 1 1/4 x 4 1/4 x 12	
5	F40003	1	HARNESSTOOLING BOARD	PLYWOOD TOOLING BOARD .150 x 28 x 41.5 LG	
6					
7	A40005	76	WIRE GUIDE GATE SPRING	AJAX WORE SPECIALTY CO. SPRING #38 (MAKES 2 PIECES)	
8	F40006	1	X-Y TOOLING PLATE	PRECISION GROUND ALUMINUM JIG PLATE .500 x 30 x 51	
9		5	CLAMP STRAP/ 3/8 STUD	MORTON MACHINE WORKS CATALOG #CS-201	
10		12	STUD/NUT	3/8-16 NC x 6 LG.	
11		10	SOC. HD. CAP SCREW	1/4-20 NC x 7/8 LG.	
12		102	SOC. HD. CAP SCREW	1/4-20 NX x 1 1/4 LG.	
13		112	S.A.E. STD. PLAIN WASHER	1/4 BOLT SIZE	
14		76	ROUND HD MACH. SCREW	#6-32 NC x 1/4 LG.	
ASSEMBLY		HARNESSTOOLING BOARD		DRAWING NUMBER F0000	

BILL OF MATERIAL

SHEET 1 OF 2

MODEL		MODEL NUMBER		GENERAL ASSEMBLY DRAWING NUMBER	
HARNESSTOOLING BOARD		AH 400		F40000	
ASSEMBLY		DEPARTMENT		DRAWING NUMBER	
RECEPTACLE LOCATING JIG		8502		F40100	
PREPARED BY		DATE	CHECKED BY	DATE	
S. OSBORNE		8-5-76			
ITEM	PART NUMBER	QUANTITY THIS ASSEMBLY	DESCRIPTION	MATERIAL OR MANUFACTURER	REMARKS
1	F40100	X	RECEPTACLE LOCATING JIG		
2	B40109	AS REQ	RECEPTACLE LOCATING RING	5/16 x 2 1/2 x 2 1/2 (STEEL)	FL GR STK
3	B40110	AS REQ	RECEPTACLE LOCATING RING	5/16 x 2 1/2 x 2 1/2 (STEEL)	FL GR STK
4	C40103	1	SWING BRACKET	2 PC 5/16 x 2 1/2 x 2 1/2 (STEEL)	FL GR STK
5	C40105	1	BASE PLATE	3/8 x 4 x 5 1/2 (STEEL)	FL GR STK
6	C40104	1	SWING BRACKET LOCATING PLATE	7/16 x 2 1/2 x 4 3/4 (STEEL)	FL GR STK
7		1	STD DOWEL	.3125 DIA x 1/2 LG (STEEL)	
8		1	SOC CAP SCR	5/16-18 NC x 3/4 LG	
9		1	SHOULDER SCR (STRIPPER BOLT)	3/8 BODY DIA x 3/4 LG	
10	A40106	1	CLAMP	3/16 x 3/4 x 1 CRS	
11		1	SOC CAP SCR	1/4-20 NC x 1/2 LG	
12		1	STD DOWEL	.125 DIA x 3/8 LG (STEEL)	
13		3	CAP SCR	#4-40 NC x 3/16 LG	
ASSEMBLY				DRAWING NUMBER	
RECEPTACLE LOCATING JIG				F40100	

BILL OF MATERIAL

SHEET 2 OF 2

MODEL		MODEL NUMBER		GENERAL ASSEMBLY DRAWING NUMBER	
HARNES TOOLING BOARD		A1 400		F40000	
ASSEMBLY		DEPARTMENT		DRAWING NUMBER	
RECEPTACLE LOCATING JIG		8-02 <td colspan="2">F40100</td>		F40100	
PREPARED BY		DATE	CHECKED BY	DATE	REMARKS
S J S - O - N		8-5-76			
ITEM	PART NUMBER	QUANTITY THIS ASSEMBLY	DESCRIPTION	MATERIAL OR MANUFACTURER	REMARKS
14		1	STD DOWEL	.116 DIA x 3/8 LC	
15	C40114	1	SPACER BLOCK	1 1/2 x 4 x 6 (ALUM)	
16	C40007	-	SAMPLE HARNES		
17	E40008	-	HARNES DATA SHEET		
18	F40009	-	CONTACT INSERTION AND HARNES LAY DATA FOR		
			SAMPLE HARNES NO. 1		
ASSEMBLY RECEPTACLE LOCATING JIG				DRAWING NUMBER	
				F40100	

X-Y TABLE

P.O. No. 635249

(No Ass'y. Dwg.)

EQUIPMENT SPECIFICATIONS

PRECISION X-Y AXIS POSITIONING TABLE

General Description-

The X-Y Axis Positioning Table is a two axis ball bushing type equipped with hardened and ground rod ways carrying precision ball bushings. The table movement is accomplished with the use of precision lead screws and anti-backlash nuts. Screw covers are standard and the table comes equipped with motor mounting brackets.

The above X-Y Ball Bushing Table will be provided on a welded steel base along with a welded steel Crossarm Bridge.

Specifications-

Table Size	36" x 60"
X Axis movement	48"
Y Axis movement	30"
Lead Screw	5 Pitch, 1.150 P.D., Precision Ground
Lead Screw Accuracy	.0005" in 12"
Positioning Accuracy	Plus or Minus .005"
Repeatability	Plus or Minus .001"

DRIVE SYSTEM

Aerotech Dual Axis Unidex 1200HR Encoded D.C. Drive System including:

- a. Model 6020HR Servo Controller with 10 amp continuous transformers mounted on a plate
- b. Serial Loading Logic Boards
- c. Model 20 Absolute/Incremental Indexers
- d. Remote binary input (ext. binary input indexers)
- e. Model 5030E 800 oz. in. D.C. Motor, tachometer 200 line encoder assembly
- f. Dual axis 19" x 8 3/4" high rack mount chassis

- g. (2) 15' interconnecting cables
- h. Remote input multiplexing
- i. Digital speed control 5 digit binary controlled
- j. ABC200 Readouts with binary outputs
- k. Drawing and instructional manuals with interface documentation to X-Y Table
- l. Special check out procedures
- m. Joystick option
- n. Maximum speed: 10 IPS or 10,000 s/sec.

The Aerotech Dual Axis Unidex 1200 HR Encoded D.C. Drive System will be capable of being driven by the DEC PDP11-V03 micro processor and will comply with specifications provided to the Wesel Manufacturing Company.

Wesel Manufacturing Company, Model 209 X-Y Table, or equivalent.

CONTROL SYSTEM

No. 60000

(No Ass'y. Dwg.)

BILL OF MATERIAL

SHEET 1 OF 1

MODEL		MODEL NUMBER		GENERAL ASSEMBLY DRAWING NUMBER	
AUTOMATED HARNESS FACILITY		AU 200		NA	
ASSEMBLY		DATE		DRAWING NUMBER	
CONTROL SYSTEM (NO ASSY DWG)		2-28-79		60000 NO ASSY	
PREPARED BY		DEPARTMENT		CHECKED BY	
F. CARTAGLIA		8507			
ITEM	PART NUMBER	QUANTITY THIS ASSEMBLY	DESCRIPTION	MATERIAL OR MANUFACTURER	REMARKS
1	60000	X	CONTROL SYSTEM		
2	C60103	X	SYSTEM BLOCK/INTERCONNECTION DIAG.		
3	C60310	X	IA6 POWER DISTRIBUTION ASS'Y		
4	C60312	X	IA6 POWER DISTRIBUTION SCHEMATIC		
5	C60322	SH 1 THRU 4	REEL TO REEL CONTROL SCHEMATIC		
6	C60342	SH 1 THRU 17	IA3 CONTROL PANEL SCHEMATIC		
7	C60343		IA3 WIREWAY ASSEMBLY LAYOUT		
8	C60350		IAS CABLE LAYOUT		
9	C60400	SH 1 THRU 3	L.S. REEL CONTROL SCHEMATIC		
10	C60410	SH 1 & 2	INVERTER CONTROL BOX ASSEMBLY		
11	C60422		SCR VOLTAGE CONTROL SCHEMATIC		
12	C60432		STEPPER MOTOR CONTROL SCHEMATIC		
13	C60502	SH 1 THRU 7	REEL TO REEL SCHEMATIC		
ASSEMBLY CONTROL SYSTEM (NO ASSY DWG)				DRAWING NUMBER 60000 NO ASSY	

MICROPROCESSOR

P.O. No. 616560

(No Drawing)

MICROPROCESSOR SPEC. SHEET

<u>ITEM</u>	<u>QTY</u>	<u>MODEL NO.</u>	<u>DESCRIPTION</u>
1	1	PDP11V03	Computer System . KD11-F Processor/4K Memory . MSV11-B, 4K Memory . RXV11, Dual Floppy Disk . DLV11, Serial Line Unit . REV11, Bootstrap Loader . H984, Cabinet . Power Supplies & Control . RT-11 Operating System Software . VT52 CRT Terminal
2	1	KEV11	Hardware Floating Point
3	1	MSV11-B	4K RAM Memory
4	1	MSV11-CD	16K RAM Memory
5	5	DRV11	16-Bit I/O
6	1	BCV1B-06	Term/Cable
7	1	BA11-ME	Expansion Box
8	1	BC05M-1F	TTY Cable
9	1	DLV11	TTY Serial Interface
10	10	BC04Z-15	Cable
11	1	QJ925-AY	FORTTRAN IV/RT11 Binaries
12	1	QJ960-AY	Scientific Subroutines Binaries
13	1	QJ920-AY	BASIC/RT11 Binaries
14	1	RX01-10	Floppy Diskettes
15	1	DRV11-B	Parallel Line DMA Interface Unit

PURCHASE FROM: Digital Equipment Corporation (or equiv.)