

AD A 080393

AFFDL-TR-79-3105
Volume II, Part I

LEVEL II

2
SC
A079803
VOL II Part II

EASY-ACLS DYNAMIC ANALYSIS
Volume II
Component Computer Programs

M. K. WAHI
G. S. DULEBA
P. R. PERKINS

BOEING MILITARY AIRPLANE DEVELOPMENT
BOEING AEROSPACE COMPANY
P.O. BOX 3999
SEATTLE, WASHINGTON 98124

SEPTEMBER 1979

TECHNICAL REPORT AFFDL-TR-3105, Volume II, Part I
Final Report for Period April 1977 to June 1979

DDC
RECEIVED
FEB 5 1980
A

Approved for public release; distribution unlimited.

AIR FORCE FLIGHT DYNAMICS LABORATORY
AIR FORCE WRIGHT AERONAUTICAL LABORATORIES
AIR FORCE SYSTEMS COMMAND
WRIGHT-PATTERSON AIR FORCE BASE, OHIO 45433

80 2 4 024

DDC FILE COPY

NOTICE

When Government drawings, specifications, or other data are used for any purpose other than in connection with a definitely related Government procurement operation, the United States Government thereby incurs no responsibility nor any obligation whatsoever; and the fact that the government may have formulated, furnished, or in any way supplied the said drawings, specifications, or other data, is not to be regarded by implication or otherwise as in any manner licensing the holder or any other person or corporation, or conveying any rights or permission to manufacture, use, or sell any patented invention that may in any way be related thereto.

This report has been reviewed by the Information Office (OI) and is releasable to the National Technical Information Service (NTIS). At NTIS, it will be available to the general public, including foreign nations.

This technical report has been reviewed and is approved for publication.



DAVID L. FISCHER, 1LT, USAF
Project Engineer

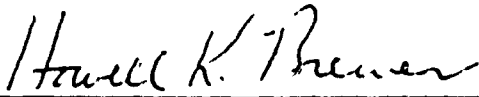

HOWELL K. BREWER
Chief, Mechanical Branch
Vehicle Equipment Division

FOR THE COMMANDER



A. B. NUTT
Director, Vehicle Equipment Division
Air Force Flight Dynamics Laboratories/FEM

"If your address has changed, if you wish to be removed from our mailing list, or if the addressee is no longer employed by your organization please notify AFFDL/FEM, W-PAFB, OH 45433 to help us maintain a current mailing list".

Copies of this report should not be returned unless return is required by security considerations, contractual obligations, or notice on a specific document.

DISCLAIMER NOTICE

THIS DOCUMENT IS BEST QUALITY PRACTICABLE. THE COPY FURNISHED TO DDC CONTAINED A SIGNIFICANT NUMBER OF PAGES WHICH DO NOT REPRODUCE LEGIBLY.

(19) REPORT DOCUMENTATION PAGE		READ INSTRUCTIONS BEFORE COMPLETING FORM	
18	1. REPORT NUMBER AFFDL/TR-79-3105 Vol 2-PT-I	2. GOVT ACCESSION NO.	3. RECIPIENT'S CATALOG NUMBER
6	4. TITLE (and Subtitle) EASY ACLS DYNAMIC ANALYSIS, Volume II, Component Computer Programs, Part I	5. TYPE OF REPORT & PERIOD COVERED FINAL APRIL 1977 - JUNE 1979	
		6. PERFORMING ORG. REPORT NUMBER	
10	7. AUTHOR(s) M. K. WAHI, G. S. DULEBA P. R. PERKINS	8. CONTRACT OR GRANT NUMBER(s) F33615-77-C-3054	
	9. PERFORMING ORGANIZATION NAME AND ADDRESS BOEING MILITARY AIRPLANE DEVELOPMENT BOEING AEROSPACE COMPANY P.O. BOX 3999, SEATTLE, WA 98124	10. PROGRAM ELEMENT, PROJECT, TASK AREA & WORK UNIT NUMBERS Project 2402, Task 240201, Work Unit 24020112	
	11. CONTROLLING OFFICE NAME AND ADDRESS AIR FORCE FLIGHT DYNAMICS LABORATORY (AFFDL/FEM) AIR FORCE WRIGHT AERONAUTICAL LABORATORIES WRIGHT PATTERSON AFB, OH 45433	12. REPORT DATE September 1979	
	14. MONITORING AGENCY NAME & ADDRESS (if different from Controlling Office) Final rept. 15 Apr 77 - 1 Jun 79	13. NUMBER OF PAGES 386	
		15. SECURITY CLASS. (of this report) UNCLASSIFIED	
		15a. DECLASSIFICATION/DOWNGRADING SCHEDULE	
16. DISTRIBUTION STATEMENT (of this Report) Approved For Public Release; Distribution Unlimited (12) 3871			
17. DISTRIBUTION STATEMENT (of the abstract entered in Block 20, if different from Report)			
18. SUPPLEMENTARY NOTES Volume II consists of Parts I and II. Part II contains Sections VI, VII, VIII, Appendix A and References.			
19. KEY WORDS (Continue on reverse side if necessary and identify by block number) EASY Subroutines Air Cushion Landing Systems FORTRAN Functions Listings			
20. ABSTRACT (Continue on reverse side if necessary and identify by block number) This volume contains a detailed description of the component subroutines and of other standard functions/subroutines which are used in the EASY dynamic analysis program. Macro-flow charts and some micro-flowcharts and listings are included. Sample output is included where appropriate.			

420 258

JCB

FOREWORD

This report presents results of work conducted by the Boeing Company, Seattle, Washington, under Air Force Contract F33615-77-C-3054 "Application of the EASY Dynamic Program to the Analysis of Air Cushion Systems on Aircraft" during the period from 15 April 1977 to 1 June 1979. This contract was conducted under the sponsorship of the Air Force Flight Dynamics Laboratory, Wright-Patterson Air Force Base, Ohio with Mr. Peters Skele and Lt. D. L. Fischer as project engineers.

This report is comprised of three volumes.

- Volume I - Component Mathematical Models
- Volume II - Component Computer Programs
(Parts I & II)
- Volume III - Description of Simulations

PRECEDING PAGE BLANK

In addition, a User's Manual (Reference 1) has been written to provide a concise reference for day to day usage.

The results presented were developed by the Boeing Aerospace Company. The program managers were A. J. P. Lloyd, H. H. Straub and J. R. Kilner. The principal investigators were M. K. Wahi, G. S. Duleba, J. R. Kilner and P. R. Perkins.

Accession For	<input checked="" type="checkbox"/>
CLASS	<input type="checkbox"/>
INDEX	<input type="checkbox"/>
FILE	<input type="checkbox"/>

A 23
Q

TABLE OF CONTENTS

SECTION	TITLE	PAGE
I.	INTRODUCTION	1
II.	SUMMARY	4
III.	STANDARD FUNCTIONS AND SUBROUTINES	5
3.1	Introduction	5
3.2	Property Functions	11
3.2.1	Function SHCP	11
3.2.2	Function PROP	11
3.2.3	Function PRND	12
3.3	Flow Functions and Subroutines	12
3.3.1	Subroutine FNFLOW	12
3.3.2	Subroutine FSFLOW	13
3.3.3	Subroutine PERF	13
3.3.4	Subroutine PERFB	13
3.3.5	Function AMACH	14
3.3.6	Function RENVX	14
3.3.7	Function HI	15
3.3.8	Function VLX	15
3.4	Transfer Functions and Subroutines	17
3.4.1	Subroutine LA	17
3.4.2	Subroutine LG	20
3.4.3	Subroutine LL	20
3.4.4	Subroutine LE	21
3.4.5	Subroutine TF	21
3.4.6	Subroutine TZ	23

TABLE OF CONTENTS (Continued)

SECTION	TITLE	PAGE
3.4.7	Subroutine RG	25
3.4.8	Subroutine FG	28
3.4.9	Subroutine AP	28
3.4.10	Subroutine AR	29
3.4.11	Subroutine IT	30
3.5	Miscellaneous Subroutines	30
3.5.1	Subroutine SW	30
3.5.2	Subroutine SX	32
3.5.3	Subroutine SY	32
3.5.4	Subroutine SZ	33
3.5.5	Subroutine TA	33
3.5.6	Subroutine TB	34
3.5.7	Subroutine AF	34
3.5.8	Subroutine MA	35
3.5.9	Subroutine FU	36
3.5.10	Subroutine MC	36
3.5.11	Subroutine SA	37
3.5.12	Subroutine SB	37
3.5.13	Subroutine MB	37
3.5.14	Subroutine FV	38
3.5.15	Subroutine RA	38
3.5.16	Subroutine RN	38
3.5.17	Subroutine S2	38
3.5.18	Subroutine S3	39

TABLE OF CONTENTS (Continued)

SECTION	TITLE	PAGE
3.5.19	Subroutine TG	39
3.5.20	Subroutine TR	39
3.5.21	Subroutine XP	39
3.5.22	Subroutine XT	40
3.6	Table Lookup Functions	40
3.6.1	Function TBL1	40
3.6.2	Function TBL2	40
3.6.3	Function TBLU1	41
3.6.4	Function TBLU2	41
3.6.5	Function TBLU3	41
3.6.6	Subroutine ETB2	41
3.6.7	Subroutine ETB3	42
3.7	Initial Condition Functions and Subroutines	42
3.7.1	Subroutine IC	42
3.7.2	Subroutine ICB	43
3.7.3	Subroutine ICFS	43
3.7.4	Subroutine ICFSB	43
3.7.5	Subroutine ICLS	44
3.7.6	Subroutine ICLSB	44
3.7.7	Subroutine KINK	44
3.7.8	Subroutine RES	44
3.7.9	Function TERRA	45
3.7.10	Subroutine VPRINB	45

TABLE OF CONTENTS (Continued)

SECTION	TITLE	PAGE
3.7.11	Subroutine VPRINT	45
3.7.12	Subroutine ELAS	46
3.7.13	Subroutine ELFX	46
3.7.14	Subroutine ELKX	46
3.7.15	Subroutine ELWR	46
3.7.16	Subroutine ENDFS	47
3.7.17	Subroutine ENDLS	47
3.7.18	Subroutine SIDEFS	47
3.7.19	Subroutine SIDELS	48
3.7.20	Subroutine XXPRT	48
3.8	Supporting Subroutines for Foster-Miller Trunk Component	48
3.8.1	Subroutine CDVCHP	48
3.8.2	Subroutine CLRNCE	49
3.8.3	Subroutine COORDN	49
3.8.4	Subroutine DYNFAN	49
3.8.5	Subroutine FLOW	49
3.8.6	Subroutine FMFAN	50
3.8.7	Subroutine FMWRIT	50
3.8.8	Subroutine FORCE	50
3.8.9	Subroutine HYCURV	50
3.8.10	Subroutine OUTFM	51
3.8.11	Subroutine PARAMS	51

TABLE OF CONTENTS (Continued)

SECTION	TITLE	PAGE
3.8.12	Subroutine PROFILE	51
3.8.13	Subroutine ROTATE	51
3.8.14	Subroutine SEGMNT	52
3.8.15	Subroutine SHAPE1	52
3.8.16	Subroutine SHAPE2	52
3.8.17	Subroutine STATIC	52
3.8.18	Subroutine STEQU	53
3.8.19	Subroutine TRUNK	53
3.8.20	Subroutine VALVE	53
IV.	COMPONENT SUBROUTINES	54
4.1	Ducting Components	54
4.1.1	DUCT DU	54
4.1.2	Split FS	56
4.1.3	Merge MG	56
4.1.4	Valve in a Duct DV	57
4.2	Fan and Ejector Components	57
4.2.1	Ejector EJ	57
4.2.2	Fan with Hysteresis FH	58
4.2.3	Fan with Surge Analysis FR	58
4.2.4	ACLS Turbofan FT	58
4.2.5	Inlet Fan FN	59
4.3	Aircraft and Aerodynamic Components	59

TABLE OF CONTENTS (Continued)

SECTION	TITLE	PAGE
4.3.1	Generalized Six Degree of Freedom (6 DOF) Rigid Body Dynamics SG	59
4.3.2	6 DOF Rigid Body Dynamics DS	60
4.3.3	4 DOF Rigid Body Dynamics FD	60
4.3.4	3 DOF Longitudinal Rigid Body Dynamics TL	60
4.3.5	3 DOF Lateral Rigid Body Dynamics TD	61
4.3.6	2 DOF Longitudinal Rigid Body Dynamics TT	61
4.3.7	Aerodynamic Variables from States VA	61
4.3.8	Longitudinal Forces and Moments OL	61
4.3.9	Lateral Forces and Moments DL	62
4.3.10	Aerodynamics Coefficients Table Lookup AC	62
4.4	Engine and Thruster Components	62
4.4.1	Engine Model (Simple) ES	62
4.4.2	Engine Model (Complex) EC	62
4.4.3	Yaw Control Thruster YC	63
4.4.4	Pitch Control Thruster PT	63
4.4.5	Roll Control Thruster RT	64
4.5	Wind Components	64
4.5.1	Gust Wind Model GW	64
4.5.2	Steady or Shear Wind WS	64
4.5.3	Summation of Wind Vectors SV	64
4.6	Air Cushion System Components	65

TABLE OF CONTENTS (Concluded)

SECTION	TITLE	PAGE
4.6.1	Inelastic Trunk Model TK	65
4.6.2	Elastic Trunk Model TS	65
4.6.3	Foster-Miller Inelastic Trunk FM & OO	66
4.6.4	Air Bag Model AB	67
4.6.5	Arresting Gear Model AS	67
4.7	Optimal Controller OC	68
4.8	Ambient Conditions FL	69
V.	FLOW CHARTS	70
VI.	SUBROUTINE LISTINGS	In Part II
VII.	ANALYSIS OF COMPONENTS	In Part II
VIII.	USER ADDED COMPONENTS	In Part II
APPENDIX A	EASY DOCUMENTATION INDEX	In Part II
REFERENCES		In Part II

LIST OF ILLUSTRATIONS

FIGURE NO.	TITLE	PAGE
1	Heat Transfer Coefficients for Flow of Air in Ducts and Across Cylinders	16
2	Calculation of Flows in Subroutine VLX Outside Normal Valve Angle Limits	18
3	Typical Response for Subroutine LA	19
4	Typical Response for subroutine LL	22
5	Typical Response for Subroutine TF	24
6	Typical Response for Subroutine TZ	26
7	Application of Switch Subroutine SW	31
8	Alternate Representations of Flow Merge	55

LIST OF TABLES

TABLE NO.	TITLE	PAGE
1	Standard Functions and Subroutines	6
2	Flowchart for subroutine AB	71
3	Flowchart for subroutine AC	73
4	Flowchart for subroutine AF	74
5	Flowchart for subroutine AMACH	75
6	Flowchart for subroutine AP	76
7	Flowchart for subroutine AR	78
8	Flowchart for subroutine AS	81
9	Flowchart for subroutine CLRNCE	84
10	Flowchart for subroutine CDVCHP	85
11	Flowchart for subroutine COORDN	86
12	Flowchart for subroutine DL	87
13	Flowchart for subroutine DS	88
14	Flowchart for subroutine DU	89
15	Flowchart for subroutine DV	90
16	Flowchart for subroutine DYNFAN	91
17	Flowchart for subroutine EC	92
18	Flowchart for subroutine EJ	94
19	Flowchart for subroutine ELAS	96
20	Flowchart for subroutine ELFX	107
21	Flowchart for subroutine ELKX	108
22	Flowchart for subroutine ELWR	109
23	Flowchart for subroutine ENDFS	112
24	Flowchart for subroutine ENDLS	119
25	Flowchart for subroutine ES	125
26	Flowchart for subroutine ETB2	126
27	Flowchart for subroutine ETB3	127
28	Flowchart for subroutine FD	128
29	Flowchart for subroutine FG	132
30	Flowchart for subroutine FH	133

LIST OF TABLES (Continued)

TABLE NO.	TITLE	PAGE
31	Flowchart for subroutine FL	135
32	Flowchart for subroutine FLOW	136
33	Flowchart for subroutine FM	139
34	Flowchart for subroutine FMFAN	156
35	Flowchart for subroutine FMWRIT	157
36	Flowchart for subroutine FN	158
37	Flowchart for subroutine FNFLOW	160
38	Flowchart for subroutine FORCE	161
39	Flowchart for subroutine FR	164
40	Flowchart for subroutine FS	165
41	Flowchart for subroutine FSFLOW	166
42	Flowchart for subroutine FT	169
43	Flowchart for subroutine FU	170
44	Flowchart for subroutine FV	171
45	Flowchart for subroutine GW	172
46	Flowchart for subroutine HI	175
47	Flowchart for subroutine HYCURV	178
48	Flowchart for subroutine IC	179
49	Flowchart for subroutine ICB	184
50	Flowchart for subroutine ICFS	189
51	Flowchart for subroutine ICFSB	190
52	Flowchart for subroutine ICLS	191
53	Flowchart for subroutine ICLSB	192
54	Flowchart for subroutine IT	193
55	Flowchart for subroutine KINK	195
56	Flowchart for subroutine LA	196
57	Flowchart for subroutine LE	197
58	Flowchart for subroutine LG	198
59	Flowchart for subroutine LL	199
60	Flowchart for subroutine MA	200
61	Flowchart for subroutine MB	201

LIST OF TABLES (Continued)

TABLE NO.	TITLE	PAGE
62	Flowchart for subroutine MC	202
63	Flowchart for subroutine MG	203
64	Flowchart for subroutine OC	204
65	Flowchart for subroutine GL	206
66	Flowchart for subroutine OO	207
67	Flowchart for subroutine OUTFM	208
68	Flowchart for subroutine PARAMS	211
69	Flowchart for subroutine PERF	212
70	Flowchart for subroutine PERFB	214
71	Flowchart for subroutine PRND	215
72	Flowchart for subroutine PROFILE	216
73	Flowchart for subroutine PROP	217
74	Flowchart for subroutine PT	218
75	Flowchart for subroutine RA	220
76	Flowchart for subroutine RENVX	221
77	Flowchart for subroutine RES	222
78	Flowchart for subroutine RG	223
79	Flowchart for subroutine RN	225
80	Flowchart for subroutine ROTATE	226
81	Flowchart for subroutine RT	227
82	Flowchart for subroutine SA	229
83	Flowchart for subroutine SB	231
84	Flowchart for subroutine SEGMNT	232
85	Flowchart for subroutine SG	242
86	Flowchart for subroutine SHAPE1	243
87	Flowchart for subroutine SHAPE2	245
88	Flowchart for subroutine SHCP	257
89	Flowchart for subroutine SIDEFS	258
90	Flowchart for subroutine SIDELS	259
91	Flowchart for subroutine STATIC	260
92	Flowchart for subroutine STEQU	295

LIST OF TABLES (Continued)

TABLE NO.	TITLE	PAGE
93	Flowchart for subroutine SV	300
94	Flowchart for subroutine SW	301
95	Flowchart for subroutine SX	302
96	Flowchart for subroutine SY	303
97	Flowchart for subroutine SZ	304
98	Flowchart for subroutine S2	306
99	Flowchart for subroutine S3	307
100	Flowchart for subroutine TA	308
101	Flowchart for subroutine TB	309
102	Flowchart for subroutine TBL1	310
103	Flowchart for subroutine TBL2	311
104	Flowchart for subroutine TBLU1	312
105	Flowchart for subroutine TBLU2	314
106	Flowchart for subroutine TBLU3	317
107	Flowchart for subroutine TD	319
108	Flowchart for subroutine TERRA	322
109	Flowchart for subroutine TF	323
110	Flowchart for subroutine TG	324
111	Flowchart for subroutine TK	325
112	Flowchart for subroutine TL	328
113	Flowchart for subroutine TR	330
114	Flowchart for subroutine TRUNK	331
115	Flowchart for subroutine TS	334
116	Flowchart for subroutine TT	347
117	Flowchart for subroutine TZ	349
118	Flowchart for subroutine VA	350
119	Flowchart for subroutine VALVE	354
120	Flowchart for subroutine VLX	355
121	Flowchart for subroutine VPRINB	357
122	Flowchart for subroutine VPRINT	359
123	Flowchart for subroutine WS	361

LIST OF TABLES (Concluded)

TABLE NO.	TITLE	PAGE
124	Flowchart for subroutine XP	364
125	Flowchart for subroutine XT	365
126	Flowchart for subroutine XXPRT	366
127	Flowchart for subroutine YC	368

SECTION I

INTRODUCTION

The EASY-ACLS Model Generation and Analysis Program is documented in three main volumes. Volume I contains the mathematical models for the standard components of the program library. This includes derivation of the dynamic equations of motion for aircraft, trunk-cushion landing systems, an air bag skid system and an arresting gear system, and a discussion of required inputs and outputs for component models. Volume II, this volume, contains a detailed description of all the component subroutines, including macro-flowcharts and detailed listings. In addition, the standard subroutines and functions called by the component subroutines are described, and sample outputs are shown. Volume III contains a description of the development, results and conclusions of EASY computer simulations accomplished during this contract. These consist of landing, takeoff, free flight and drop test simulations. A summary document (Reference 1)* has also been prepared as a User's Manual.

In the EASY program, a user defines the system to be analyzed by specifying the individual components and their interconnections. Each of these components is a subroutine of the main program, and each has input data requirements which must be supplied by the user. In addition to the library of component subroutines, there is also a set of standard subroutines and functions which are called automatically as they are required, and for which the user need not supply any input data. Such standard functions and subroutines are described in Section 3 of this volume. In addition, Section 3 also contains a description of certain linear routines such as first and second order transfer functions, time delays, general controllers, and switches. Subroutines associated with particular ACLS components are described in Section 4.

*References are located in Volume II, Part II.

For each function or subroutine described in Sections 3 and 4, the theory and data sources are given or the appropriate Section of Volume I is referenced. Macro-flowcharts and some micro-flow charts showing the main decision points and calculation procedures are shown. For all functions and subroutines a listing is given. Included in the listing is a detailed description of the input/output list. The inputs and outputs are divided into the following classifications:

- o Output State
- o Output Derivative
- o Integrator Control
- o Output Variable
- o Input Variable
- o Input Parameter

These terms are discussed fully in Reference 2, but will be reviewed briefly here in order to assist in understanding the subroutines and functions. An Output State is a variable whose derivative (Output Derivative) is calculated within the subroutine. The Integrator Control is an integer whose value is set by the main program. The Output Derivative is calculated within the subroutine unless the integrator is "frozen" by setting the Integrator Control equal to zero. For every Output State there is one Output Derivative and one Integrator Control. Output Variables, as the name implies, are variables which are calculated within a function or subroutine and are then output from that function or subroutine. Similarly, input variables are variables which are input to a function or subroutine. Input Parameters are also input to a function or subroutine, but are generally constant during a simulation. For example, the inlet flow rate or temperature to a component would be an Input Variable, whereas a controller gain or duct length would be an Input Parameter. In general, the program user must supply data inputs for all Input Parameters; however many Input Variables will be automatically satisfied by the interconnections between adjacent components. This is discussed more fully in Reference 2.

The functions and subroutines described in Sections 3 and 4 contain error controls which are of two types, namely for fatal and non-fatal errors. The latter type are by far the more common, and occur when, for example, fluid properties are sought outside the range for which valid data are available. It is desirable that non-fatal error diagnostic messages should not be printed everytime they occur; for example, during the course of finding a steady state solution, it is of no significance if invalid data are used provided the final steady state point is based on valid data. The printout of warning diagnostics is controlled by the parameter IERR (= 1 for printout) which is set by the main program and is communicated through the common block ERMESS. For errors which are of sufficient significance to warrant a program stop, the parameter IFATAL is set equal to 1 within the subroutine or function and is communicated back to the main program through the same common block ERMESS.

Other common blocks which are used in the functions and subroutines are:

- CTIME - For time
- CIO - For read and write control

SECTION II

SUMMARY

The EASY Model Generation and Analysis program is documented in three main volumes. Volume I contains the mathematical models, Volume II (this volume) the component subroutines, and Volume III the description of various dynamic simulations. A User's Manual (Reference 1) has also been prepared to provide a convenient reference guide.

This volume contains a detailed description of the component subroutines, and of other standard functions and subroutines which are called by the component subroutines. Flowcharts and listings are given, including a full description of the input/output lists. Theory and data sources are given, or the relevant section of Volume I is referenced. Sample output is included where appropriate. The procedures for running single components on the EASY program are briefly reviewed, and guidelines to assist users in writing their own subroutines are described.

SECTION III

STANDARD FUNCTIONS AND SUBROUTINES

3.1 Introduction

The EASY Model Generation and Analysis program contains a number of standard functions and subroutines which have been divided into six categories, namely:

Property functions and subroutines	- Section 3.2
Flow functions and subroutines	- Section 3.3
Transfer functions and subroutines	- Section 3.4
Miscellaneous subroutines	- Section 3.5
Table look up functions	- Section 3.6
Initial condition functions and subroutines	- Section 3.7
Supporting subroutines for Foster-Miller trunk component	- Section 3.8

The property, the flow, the table look up, and the initial condition functions and subroutines are all called by component subroutines, and their input data requirements are automatically satisfied by the calling subroutine. The transfer functions are generally used to model part or all of a component, and are therefore included in the library of standard components (see Reference 1). However, as they are general dynamic models and are not associated particularly with any one type of ACLS component, they are included in this section rather than in the component subroutines discussed in Section 4 of this volume. The miscellaneous functions include routines for providing input data to the models in tabular form, and for changing variable or parameter inputs during a simulation. Table 1 lists all the standard functions and subroutines and briefly describes their purpose. A full description of each routine is given in the following sections.

Table 1 STANDARD FUNCTIONS AND SUBROUTINES

SECTION NO.	FUNCTION OR SUBROUTINE NAME	PURPOSE
3.2.1	SHCP	Specific heat of humid air
3.2.2	PROP	Property of fluids
3.2.3	PRND	Prandtl number of fluids
3.3.1	FNFLOW	Flow rate in a duct given pressure and loss factor, using tabular data
3.3.2	FSFLOW	Flow rate in a duct given pressure and loss factor, using tabular data
3.3.3	PERF	Trunk element orifice areas for flow to cushion and atmosphere
3.3.4	PERFB	Air bag element orifice areas for flow to atmosphere
3.3.5	AMACH	Mach number in a duct
3.3.6	RENVX	Reynolds number
3.3.7	HI	Convective heat transfer coefficients for flow in ducts and across cylinder
3.3.8	VLX	Flow across butterfly, gate and globe valves
3.4.1	LA	First order lag (time constant form)
3.4.2	LG	First order lag (pole form)
3.4.3	LL	Lead lag (time constant form)
3.4.4	LE	Lead lag (pole-zero form)
3.4.5	TF	Second order transfer function with first order numerator

Table 1 STANDARD FUNCTIONS AND SUBROUTINES

SECTION NO.	FUNCTION OR SUBROUTINE NAME	PURPOSE
3.4.6	TZ	Second order transfer function with second order numerator
3.4.7	RG	Rate Gyro Dynamics and Saturation
3.4.8	FG	F ight-ground controller
3.4.9	AP	Autopilot pitch controller (Jindivik)
3.4.10	AR	Autopilot roll controller (Jindivik)
3.4.11	IT	Integrator with saturation
3.5.1	SW	Switch control for one variable
3.5.2	SX	Switch control for two variables
3.5.3	SY	Switch control for three variables
3.5.4	SZ	Switch control for four variables
3.5.5	TA	Tabular input routine for two variables
3.5.6	TB	Tabular input routine for four variables
3.5.7	AF	Analytical function generator
3.5.8	MA	Multiply and add
3.5.9	FU	Arbitrary function generator
3.5.10	MC	Multiply and add with three variables
3.5.11	SA	Saturation
3.5.12	SB	Saturztion with dead band
3.5.13	MB	Multiply, add and divide
3.5.14	FV	Two dimension function generator

Table 1 STANDARD FUNCTIONS AND SUBROUTINES

SECTION NO.	FUNCTION OR SUBROUTINE NAME	PURPOSE
3.5.15	RA	Random number generator function
3.5.16	RN	Random number generator
3.5.17	S2	Sum forces and moments (2 sets of inputs)
3.5.18	S3	Sum forces and moments (3 sets of inputs)
3.5.19	TG	Transform engine thrust into body axis
3.5.20	TR	Transform vectors body to earth axis
3.5.21	XP	Transform angular rates
3.5.22	XT	Transform torques
3.6.1	TBL1	Linear interpolation (one ind. variable)
3.6.2	TBL2	Linear interpolation (two ind. variables)
3.6.3	TBLU1	Polynomial interpolation (one ind. variable)
3.6.4	TBLU2	Polynomial interpolation (two ind. variables)
3.6.5	TBLU3	Polynomial interpolation (three ind. variables)
3.6.6	ETB2	Linear interpolation (two independent variables) Supports TS
3.6.7	ETB3	Linear interpolation (three independent variables) Supports TS
3.7.1	IC	Initial condition package (trunk)

Table 1 STANDARD FUNCTIONS AND SUBROUTINES

SECTION NO.	FUNCTION OR SUBROUTINE NAME	PURPOSE
3.7.2	ICB	Initial condition package (air bag)
3.7.3	ICFS	Free shape equations (trunk)
3.7.4	ICFSB	Free shape equations (air bag)
3.7.5	ICLS	Loaded shape equations (trunk)
3.7.6	ICLSB	Loaded shape equations (air bag)
3.7.7	KINK	Kink wave angle equations (arresting cable)
3.7.8	RES	Arresting cable strain equations
3.7.9	TERRA	Terrain model
3.7.10	VPRINB	Air bag arrays print control
3.7.11	VPRINT	Trunk arrays print control
3.7.12	ELAS	Initial condition package for elastic trunk TS
3.7.13	ELFX	Incomplete elliptic integral of the 2nd kind
3.7.14	ELKX	Complete elliptic integral of the 2nd kind
3.7.15	ELWR	Prints properties of elastic trunk TS
3.7.16	ENDFS	Equations for elastic trunk-end element-free shape
3.7.17	ENDLS	Equations for elastic trunk-end element-loaded shape
3.7.18	SIDEFS	Equations for elastic trunk-side element-free shape
3.7.19	SIDELS	Equations for elastic trunk-side element-loaded shape
3.7.20	XXPRT	Prints elastic trunk parameters during simulation

Table 1 STANDARD FUNCTIONS AND SUBROUTINES

SECTION NO.	FUNCTION OR SUBROUTINE NAME	PURPOSE
3.8.1	CDVCHP	Updates cushion volume-pressure parameters (FM)*
3.8.2	CLRNC	Ground clearance for trunk segments (FM)*
3.8.3	COORDN	Ground coordinates of trunk segments (FM)*
3.8.4	DYNFAN	Fan dynamic characteristics (FM)*
3.8.5	FLOW	Dynamic flow in ACLS (FM)*
3.8.6	FMFAN	Fan static characteristics (FM)*
3.8.7	FMWRIT	Prints ACLS input data (FM)*
3.8.8	FORCE	ACLS forces (FM)*
3.8.9	HYCURV	Side trunk height (FM)*
3.8.10	OUTFM	Updates variables during simulation (FM)*
3.8.11	PARAMS	Default values for ACLS parameters (FM)*
3.8.12	PROFILE	Defines ground elevation (FM)*
3.8.13	ROTATE	Vehicle-to-initial vector transformation (FM)*
3.8.14	SEGMNT	Divides trunk into segments (FM)*
3.8.15	SHAPE1	Initial estimates of ACLS areas and volumes (FM)*
3.8.16	SHAPE2	ACLS areas and volumes (FM)*
3.8.17	STATIC	Load maps and static equilibrium conditions (FM)*
3.8.18	ST EQU	Defines ACLS state derivatives (FM)*
3.8.19	TRUNK	Trunk cross section parameters (FM)*
3.8.20	VALVE	Relief valve orifice area (FM)*

*FOSTER-MILLER ACLS MODEL

3.2 Property Functions and Subroutines

3.2.1 Function SHCP

The purpose of function SHCP is to calculate the specific heat of an air-water vapor mixture. The function is called by many of the component subroutines for calculating specific heat, and hence the gas constant and the ratio of specific heats. The method is described in Reference 2, Volume I, Appendix A and uses property data from References 3 and 4. The function is valid for temperatures of 300-1600°R, and a warning diagnostic message is printed if the temperature is outside this range. Table 88 shows a flowchart and Table 214 gives a detailed listing. Required inputs are the temperature (T) and specific humidity (SH).

3.2.2 Function PROP

The purpose of function PROP is to calculate the properties of several fluids. The properties, all of which are assumed to be functions of temperature only, are specific heat, viscosity, thermal conductivity and density. The fluids included in the routine are:

- o Dry air
- o Water at saturation pressure
- o 60%/40% Ethylene Glycol/water
- o Heat transport fluid FC-75
- o Fuel JP-4 (MIL-F-5624)
- o Heat transport fluid DC-331
- o Hydraulic fluid (MIL-H-83282)
- o Hydraulic fluid (MIL-H-5606)

The function uses polynomial approximations to property data obtained from References 3, 5 and 6. Table 73 shows a flowchart and Table 199 gives a detailed listing. Limitations on the allowable temperature range for each fluid are shown in the listing. A warning diagnostic is printed if

temperatures are outside the allowable range. The density calculation for dry air is invalid, and the perfect gas equation should be used instead. Required inputs are integers identifying the fluid and the required property, and the absolute temperature.

3.2.3 Function PRND

The purpose of function PRND is to calculate the Prandtl number of fluids. The function calls PROP (Section 3.2.2) to calculate the specific heat, thermal conductivity and viscosity, with the exception that the specific heat of moist air is obtained from SHCP. As discussed in Reference 2, Volume I, Appendix A values of thermal conductivity and viscosity for dry air can be used in the calculation of Prandtl number of an air/water vapor mixture with a negligible effect on accuracy. No diagnostic messages are included in PRND, but will be called from PROP and SHCP (Section 3.2.1) if the temperature lies outside the valid range for the particular fluid. Table 71 shows a flowchart and Table 197 gives a detailed listing. Input requirements are an integer identifying the fluid (as in PROP), the absolute temperature and the specific humidity. The latter input is used for the case of air only.

3.3 Flow Functions and Subroutines

3.3.1 Subroutine FNFLOW

The purpose of subroutine FNFLOW is to calculate the flow rate and Chester Smith function for flow in a constant area section, given the upstream and downstream pressures, temperature, effective area and K (pressure loss) factor. The method is described in Reference 2, Volume I, Appendix F. The Chester Smith function is stored in a data array as a function of pressure ratio. The subroutine can also be used to calculate the flow across an orifice, in which case the K factor should be set equal to one. The input value of K factor must always be greater than zero. In the event that the input value of downstream pressure exceeds the upstream pressure, the subroutine calculates negative flow rates and Chester Smith functions.

A flowchart for the subroutine is shown as Table 37 and Table 163 gives a detailed listing which includes the full input/output list.

3.3.2 Subroutine FSFLOW

The purpose of subroutine FSFLOW is the same as that of FNFLOW except an additional output parameter "SFN" has been added. Parameter SFN is the slope of compressible flow factor FN with respect to the pressure ratio $P1/P2$. Subroutine FSFLOW is used exclusively for calculating cushion to atmosphere flow rate in the trunk subroutine TK.

A flowchart for the subroutine is shown as Table 41 and Table 167 gives a detailed listing which includes the full input/output list.

3.3.3 Subroutine PERF

This is a special purpose subroutine called only by the trunk component TK. The purpose of subroutine PERF is to calculate orifice areas for flow to atmosphere and to cushion through the lubrication holes provided on the underside of a trunk. Thirteen combinations of perforation arrangements are treated and are functions of free or loaded trunk shape and perforations being on the flattened or free parts of the trunk.

A flowchart for the subroutine is shown as Table 69 and Table 195 gives a detailed listing which includes the full input/output list.

3.3.4 Subroutine PERFB

This is also a special purpose subroutine called only by the Air Bag Component AB. Its purpose is same as that of the subroutine PERF except the perforation arrangements which are limited to six and there is no cushion pressure.

A flowchart for the subroutine is shown as Table 70 and Table 196 gives a detailed listing which includes the full input/output list.

3.3.5 Function AMACH

The purpose of function AMACH is to calculate the Mach number of moist air flowing in an element of known cross-sectional area, given the pressure, temperature, flow rate and specific humidity. The method is described in Reference 2, Volume I, Appendix F. The function $f(M)$ defined in equation F-2 is stored in two data arrays. The first array covers a range of values of $f(M)$ from zero through 0.50 at increments of .02, corresponding to Mach numbers of zero through .632. The second array covers the range .50 through .58 at increments of .01, corresponding to Mach numbers of .632 through 1.0. A warning diagnostic message is printed if the calculated value of $f(M)$ lies outside the range covered by the data arrays.

A flowchart for the function is shown as Table 5 and Table 131 gives a detailed listing which includes the full input/output list.

3.3.6 Function RENVX

The purpose of function RENVX is to calculate the Reynolds number of fluid flowing in a duct of circular cross-section, given the flow rate, temperature and duct diameter. The function calls function PROP (Section 3.2.2) to determine the fluid viscosity at the given temperature. As discussed in Reference 2, Volume I, Appendix A, values of viscosity for dry air can be used for the calculation of Reynolds number of an air/water vapor mixture with negligible effect on accuracy. The function output is the absolute value of Reynolds number, irrespective of the sign of the flow rate.

A flowchart for the function is shown as Table 76 and Table 202 gives a detailed listing which includes the full input/output list.

3.3.7 Function HI

The purpose of function HI is to calculate the convective heat transfer coefficient for fluid flow in ducts and for flow across cylinders. The latter capability is primarily of significance for determining the response rate of temperature sensors. The function uses conventional correlations for Nusselt number against Reynolds number and Prandtl number for transitional and turbulent flow in ducts, and for Nusselt number against Graetz number for laminar flow in ducts. For flow across cylinders, a correlation of Nusselt number against Reynolds number is used for air, and Nusselt number against Reynolds number and Prandtl number for liquids. The complete equations and references are given in Reference 2, Volume I, Appendix F. Fluid properties are obtained from function PROP (Section 3.2.2).

A flowchart for the function is shown as Table 46 and Table 172 gives a detailed listing which includes the full input/output list. Figure 1 shows heat transfer coefficients for air flow in ducts and across cylinders.

3.3.8 Subroutine VLX

The purpose of subroutine VLX is to calculate the weight flow of air across butterfly, gate and globe type valves. For butterfly and globe valves, the geometric flow area is first calculated, and the effective area is then determined assuming discharge coefficients of 0.67 and 0.80, respectively. For gate valves the flow is calculated using a table of K factor versus fractional opening. A full description of the method and equations is given in Reference 2, Volume I, Section 3.7. In the event that the downstream pressure is greater than the upstream value, the calculated value of flow will be negative. For globe valves, the input value of poppet diameter must be greater than or equal to the poppet seat diameter.

The valve opening (degrees or fractional opening) is an input to subroutine VLX. In a system analysis, the valve opening will generally be an output

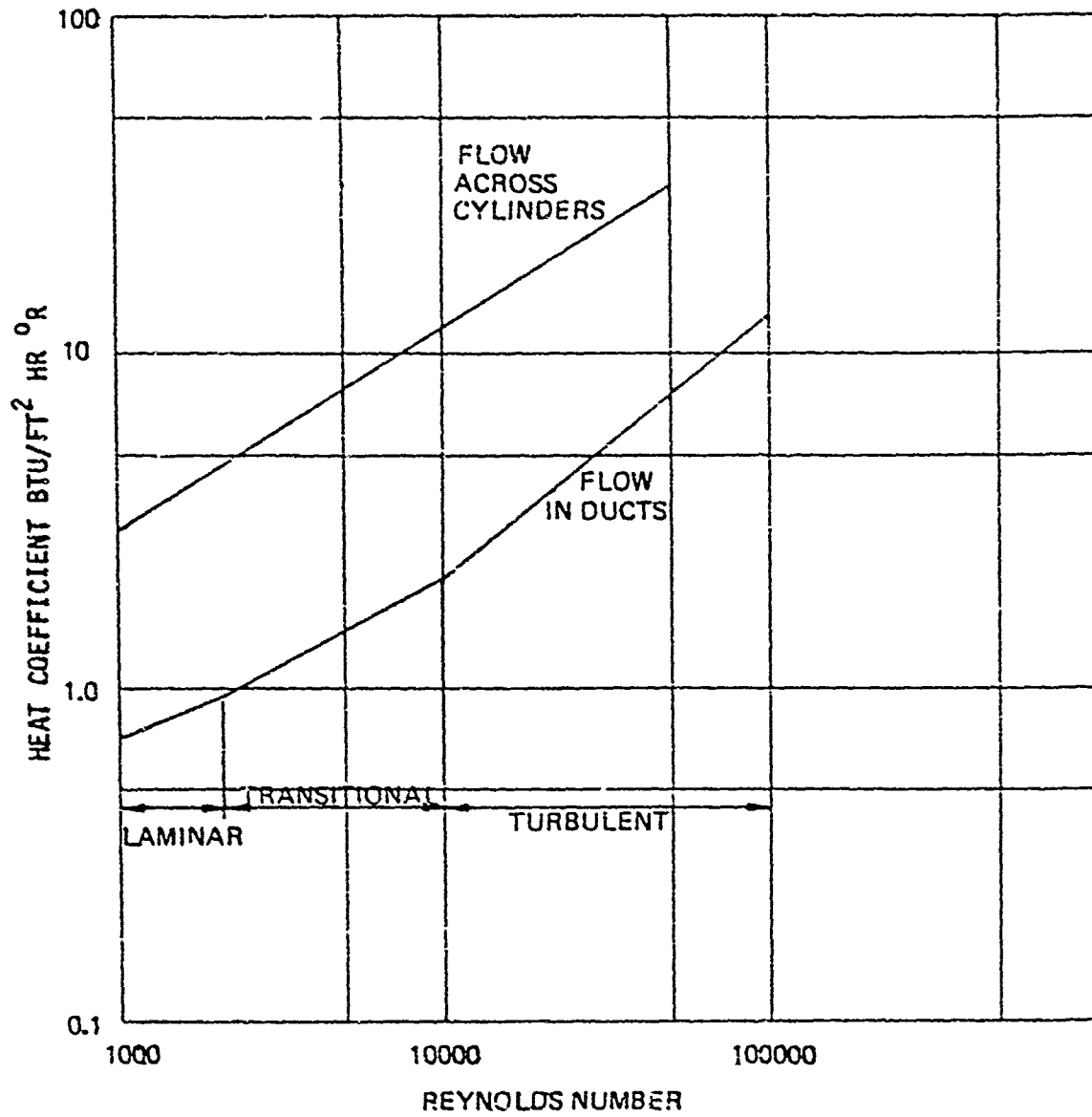

Figure 1 Heat Transfer Coefficients for Flow of Air In Ducts and Across Cylinders

variable from, or calculated within, a control component such as a pressure regulator or temperature controller. During the course of searching for a steady state solution, it is possible that the valve opening will lie outside the normal range. For example, a butterfly valve opening of -10^0 or 105^0 might be input to VLX. Although such a value is clearly not a valid in a steady state solution, it is desirable that subroutine VLX calculate reasonable values of flow rate at such values in order to permit convergence to the correct steady state solution. The method incorporated into VLX is illustrated in Figure 2(a) for butterfly valves, and Figure 2(b) for globe and gate valves.

A flowchart for the subroutine is shown as Table 120 and Table 246 gives a detailed listing which includes the full input/output list.

3.4 Transfer Functions and Subroutines

3.4.1 Subroutine LA

The purpose of subroutine LA is to simulate a first order lag defined as:

$$\frac{FO}{FIN} = \frac{\text{Gain}}{(1 + TC \times s)} \quad 3.4-1$$

where

FO	is the output	GAIN	is the gain
FIN	is the input	TC	is the time constant

and s is the Laplace operator

The time constant TC must not equal zero.

Table 56 shows a flowchart for the subroutine and Table 182 gives a detailed listing which includes the full input/output list. Figure 3(a) shows a typical calculated response to a unit step change in input, which agrees with the analytical response given by

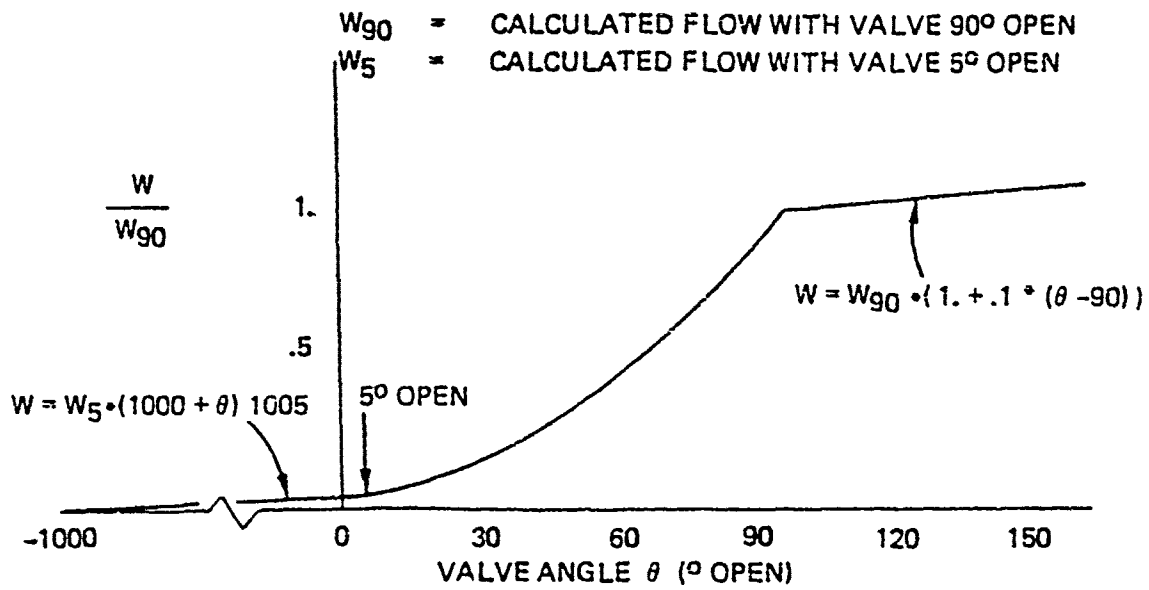

Figure 2 (a) Flow Calculation for Butterfly Valves

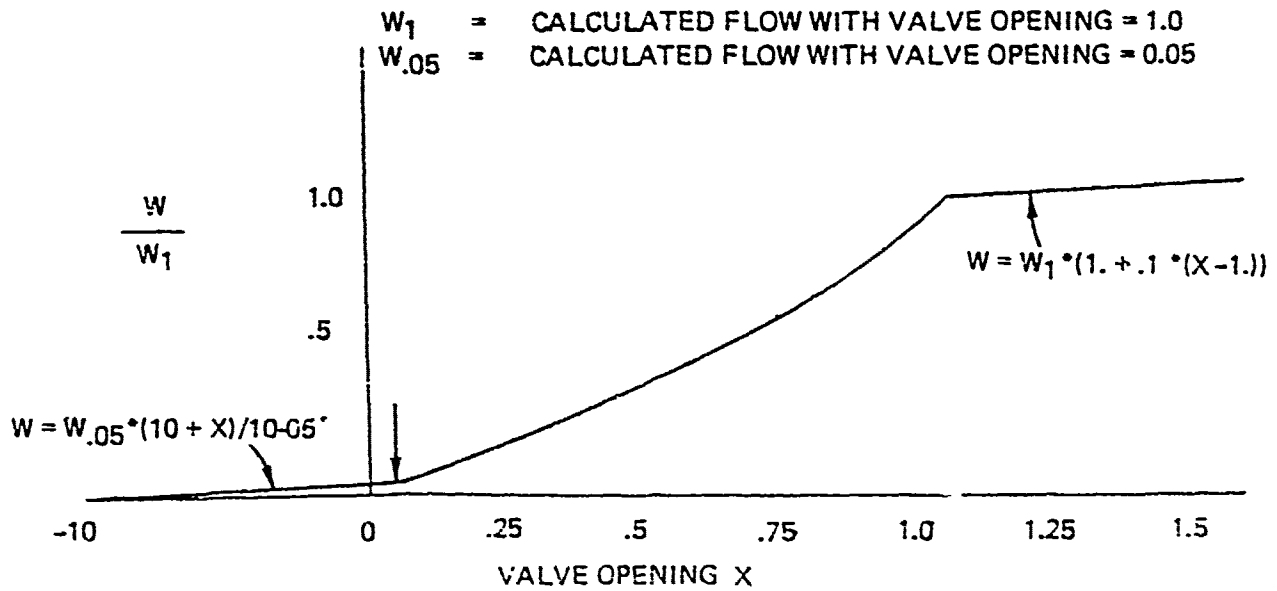

Figure 2 - (b) Flow Calculation for Globe and Gate Valves

Figure 2 Calculation of Flows in Subroutine VLX Outside Normal Valve Angle Limits

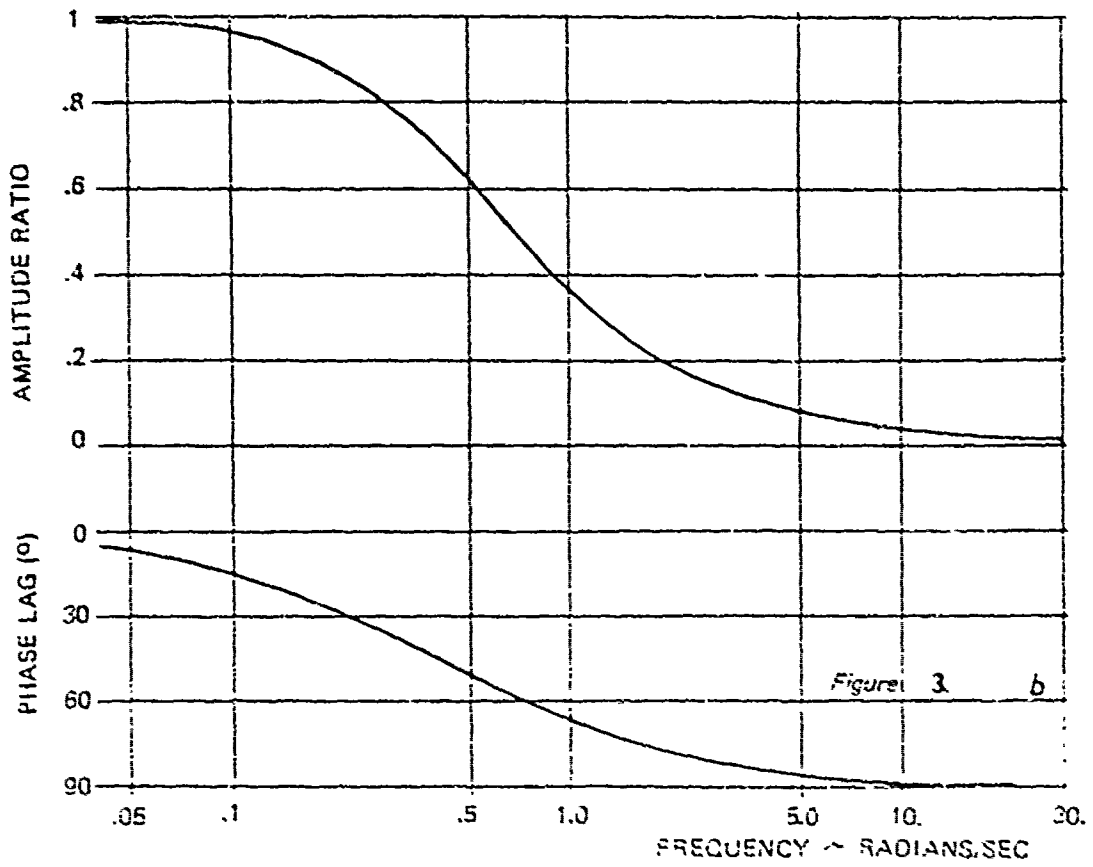
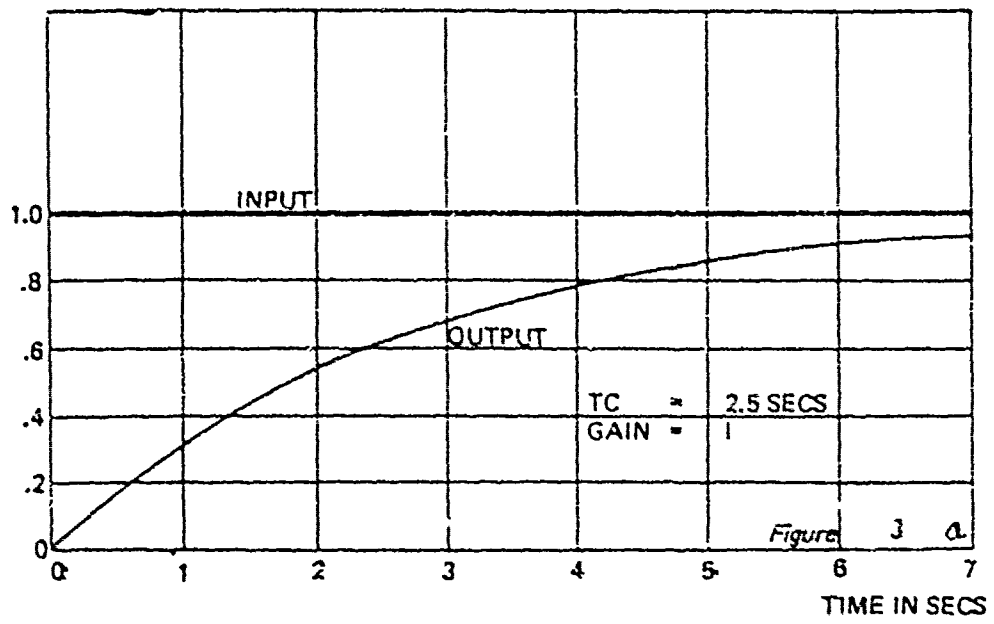

Figure 3 Typical Response for Subroutine LA

$$FO = (1 - e^{-t/TC}) \times \text{GAIN} \quad 3.4-2$$

where t is time. Figure 3(b) shows the frequency response.

3.4.2 Subroutine LG

The purpose of subroutine LG is to simulate a first order lag defined by:

$$\frac{FO}{FIN} = \frac{ZO}{s+PO} \quad 3.4.3$$

where

FO	is the output	ZO	is the zero location
FIN	is the input	PO	is the pole location

and s is the Laplace operator.

A flowchart for the subroutine is shown as Table 58 and Table 184 gives a detailed listing.

3.4.3 Subroutine LL

The purpose of subroutine LL is to simulate a lead-lag defined by:

$$\frac{FO}{FIN} = \text{GAIN} \frac{(1 + TC1 \times s)}{(1 + TC2 \times s)} \quad 3.4-4$$

where

FO	is the output	GAIN	is the gain
FIN	is the input	TC1 and TC2	are time constants

and s is the Laplace operator.

The time constant TC2 must not equal zero.

Table 59 shows a flowchart for the subroutine and Table 185 gives a detailed listing which includes the full input/output list. Table 4(a) shows a typical calculated response to a unit step change in input, which agrees with the analytical response given by

$$\frac{FO}{FIN} = \left(1 + \frac{(TC1 - TC2)}{TC2} e^{-t/TC2}\right) \times \text{GAIN} \quad 3.4-5$$

where t is time. Figure 4(b) shows the frequency response.

3.4.4 Subroutine LE

The purpose of subroutine LE is to simulate a first order lead-lag defined by:

$$\frac{FO}{FIN} = \text{GAIN} \frac{s + Z0}{s + P0} \quad 3.4-6$$

where

FO	is the output	GAIN	is the gain
FIN	is the input	Z0	is the zero location
s	is the Laplace operator,	P0	is the pole location

A flowchart for the subroutine is shown as Table 57 and Table 183 gives a detailed listing.

3.4.5 Subroutine TF

The purpose of subroutine TF is to simulate a second order transfer function with first order numerator defined by:

$$\frac{FO}{FIN} = \frac{Z1 \times s + Z0}{s^2 + P1 \times s + P0} \quad 3.4-7$$

where FO is the output

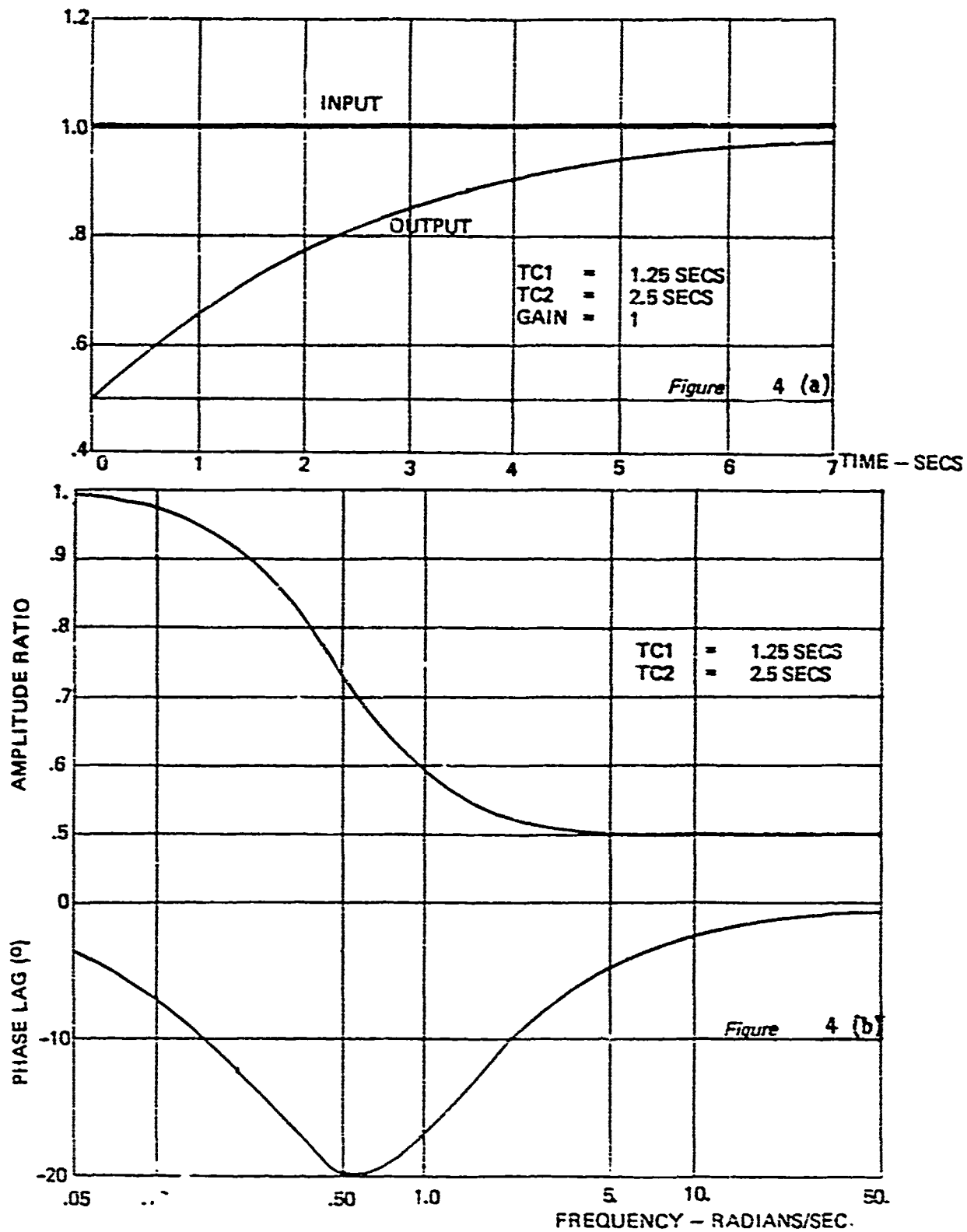

Figure 4 Typical Response for Subroutine LL

FIN is the input
 Z0, Z1, P0, and P1 are coefficients
 and s is the Laplace operator

Table 109 shows a flowchart for the subroutine and Table 235 gives a detailed listing which includes the full input/output list. Figure 5(a) shows the calculated response to a unit step change in input, which agrees with the analytical response given by

$$F0 = Ae^{-\gamma t} \cos \omega t + \left(\frac{B - \gamma A}{\omega}\right) e^{-\gamma t} \sin \omega t - A \quad 3.4-8$$

where

$$A = -\frac{Z0}{P0}$$

$$B = Z1 - \frac{Z0 \times P1}{P0}$$

$$\omega^2 = P0 - \frac{(P1)^2}{2}$$

$$\gamma = \frac{P1}{2}$$

and t is the time

Figure 5(b) shows the frequency response.

3.4.6 Subroutine TZ

The purpose of subroutine TZ is to simulate a second order transfer function with second order numerator defined by

$$\frac{F0}{FIN} = \frac{Z2 \times s^2 + Z1 \times s + Z0}{s^2 + P1 \times s + P0} \quad 3.4-9$$

where F0 is the output

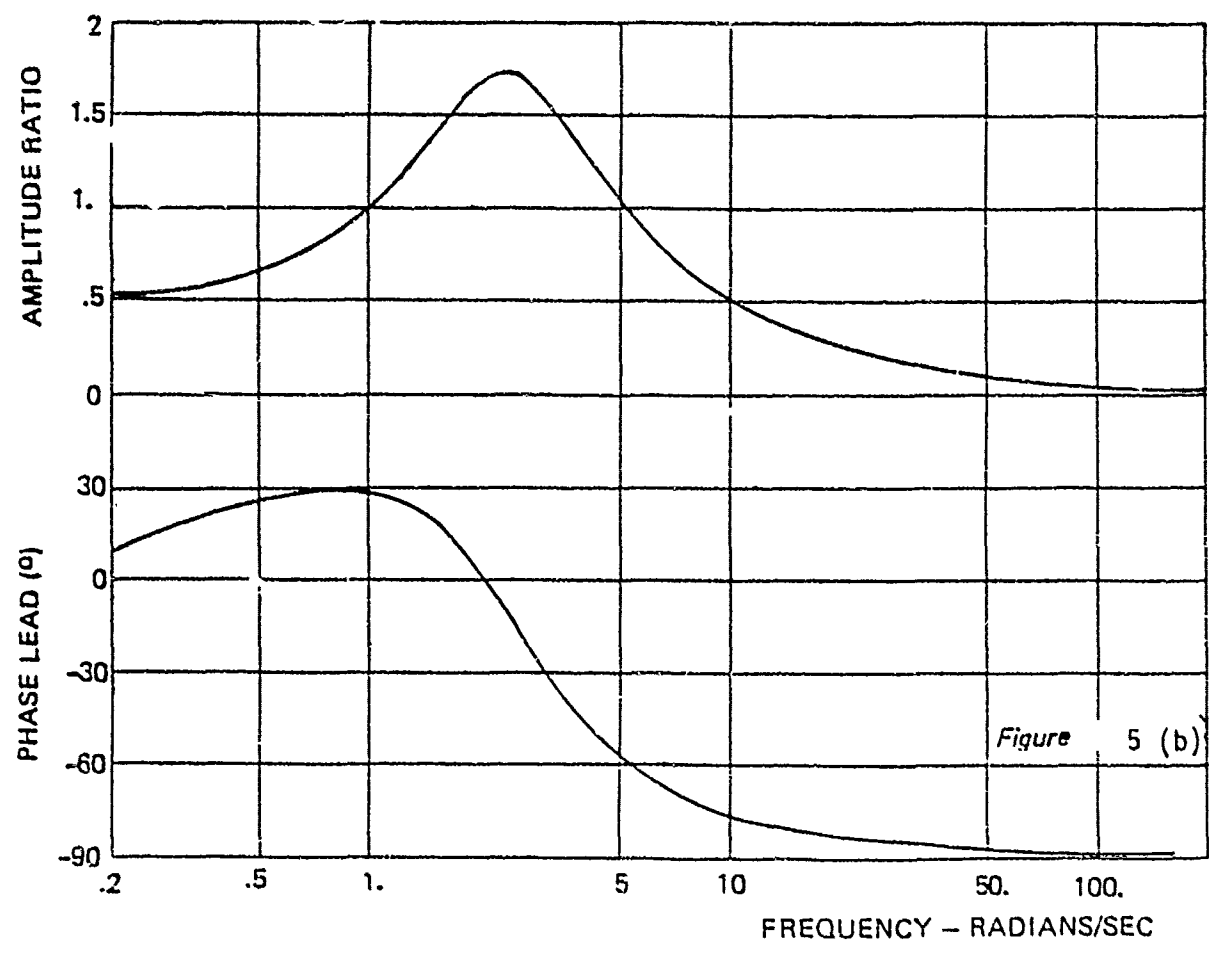
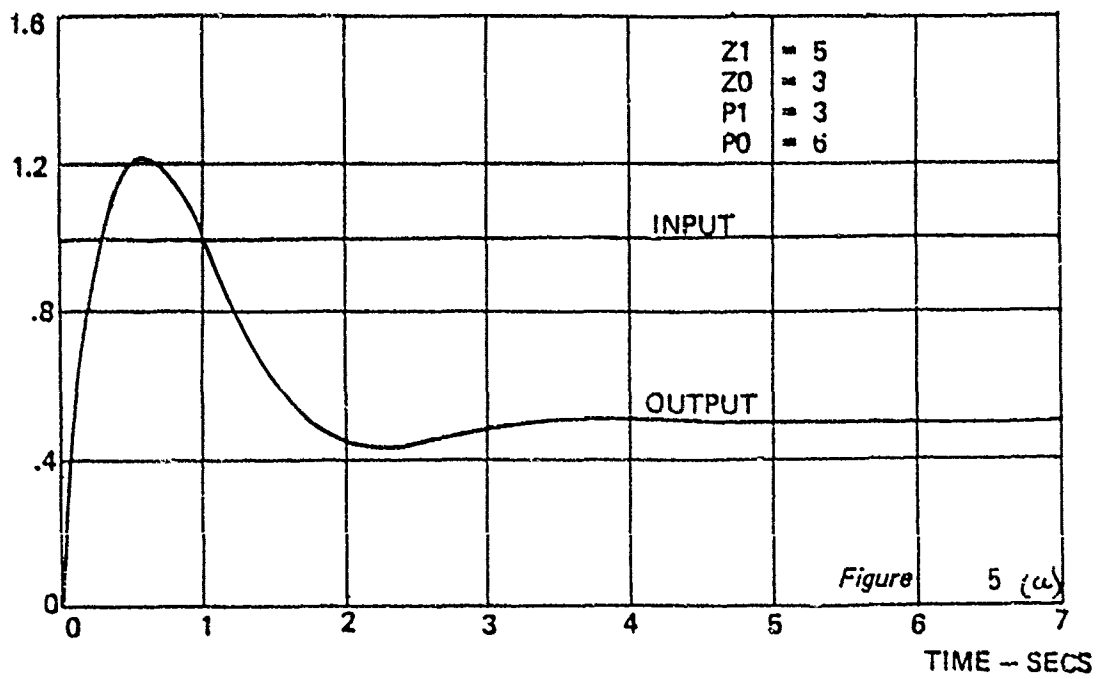

Figure 5 Typical Response for Subroutine TF

FIN is the input

Z0, Z1, Z2, P0, and P1 are coefficients

and s is the Laplace operator.

Table 117 shows a flowchart for the subroutine and Table 243 gives a detailed listing which includes the full input/output list. Figure 6(a) shows the calculated response to a unit step change in input, which agrees with the analytical response given by

$$F0 = Ae^{-\gamma t} \cos \omega t + \left(\frac{B - \gamma A}{\omega}\right)e^{-\gamma t} \sin \omega t + C \quad 3.4-10$$

where

$$A = Z2 - \frac{Z0}{P0}$$

$$B = Z1 - \frac{Z0 \times P1}{P0}$$

$$C = \frac{Z0}{P0}$$

$$\omega^2 = P0 - \left(\frac{P1}{2}\right)^2$$

$$\gamma = \frac{P1}{2}$$

and t is the time.

Figure 6(b) shows the frequency response.

3.4.7 Subroutine RG

The purpose of subroutine RG is to simulate dynamics and saturation of three (roll, pitch, yaw) rate gyros. The same 2nd order dynamics and saturation limit is applied to each rate gyro. Saturation is applied by increasing feedback signal around integrators by a factor of 100.

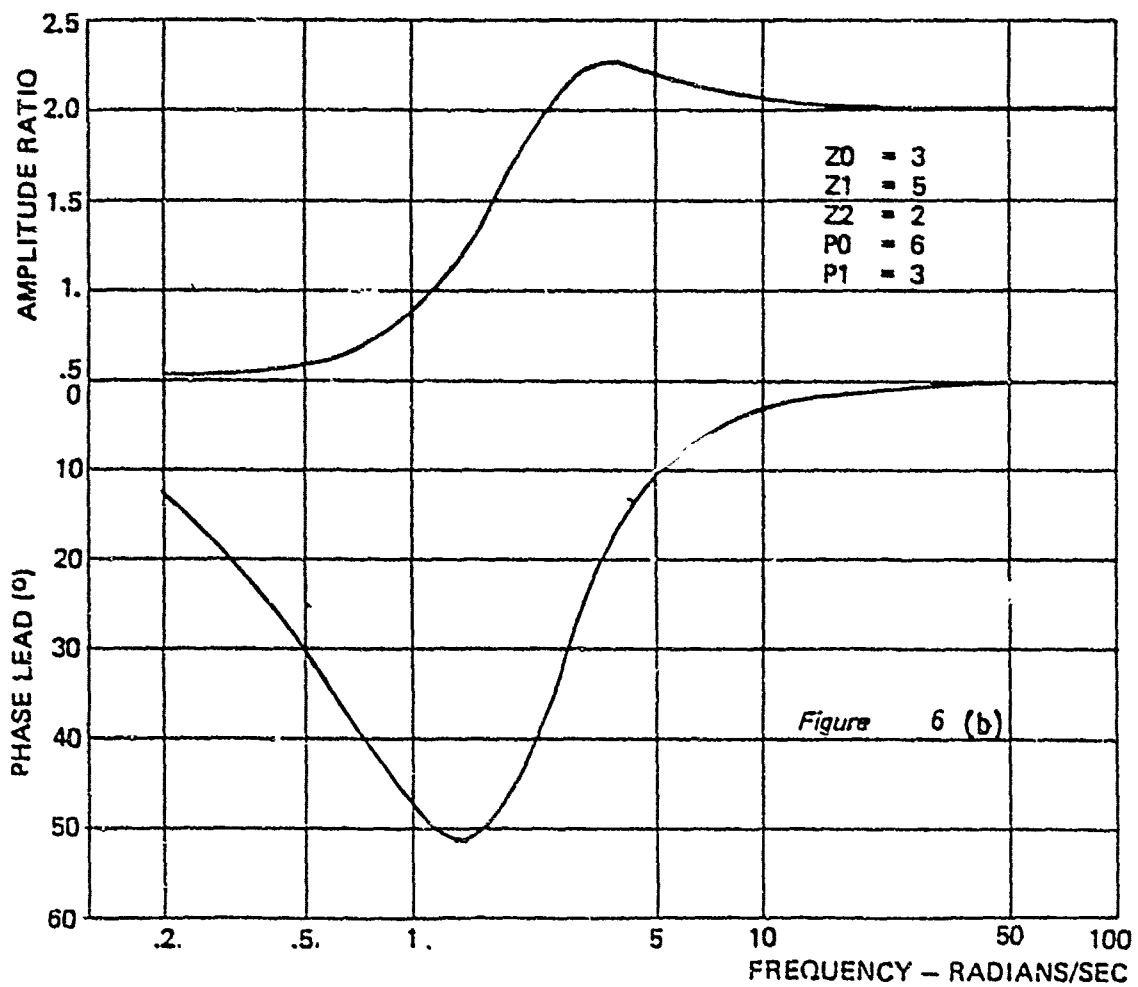
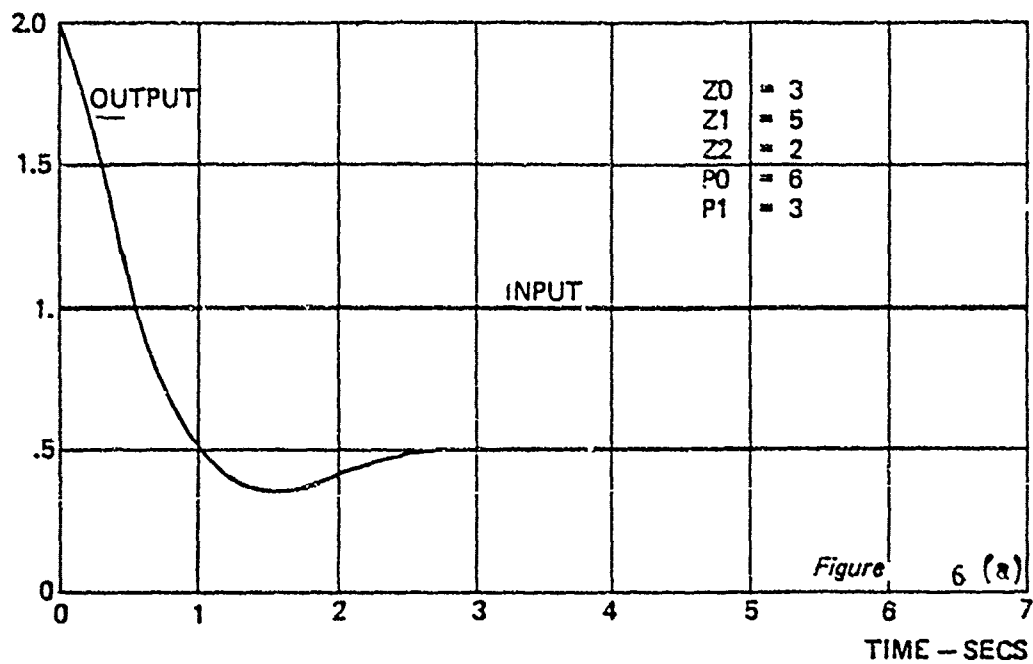
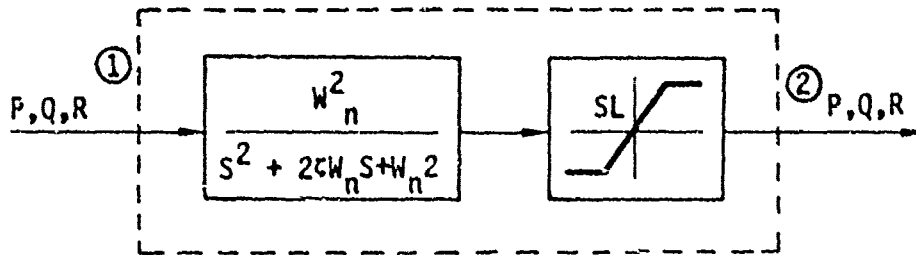

Figure 6 Typical Response for Subroutine TZ



A flowchart for the subroutine is shown as Table 78 and Table 204 gives a detailed listing which includes the input/output list.

3.4.8 Subroutine FG

The purpose of subroutine FG is to simulate a simple general purpose flight and ground controller for aircraft.

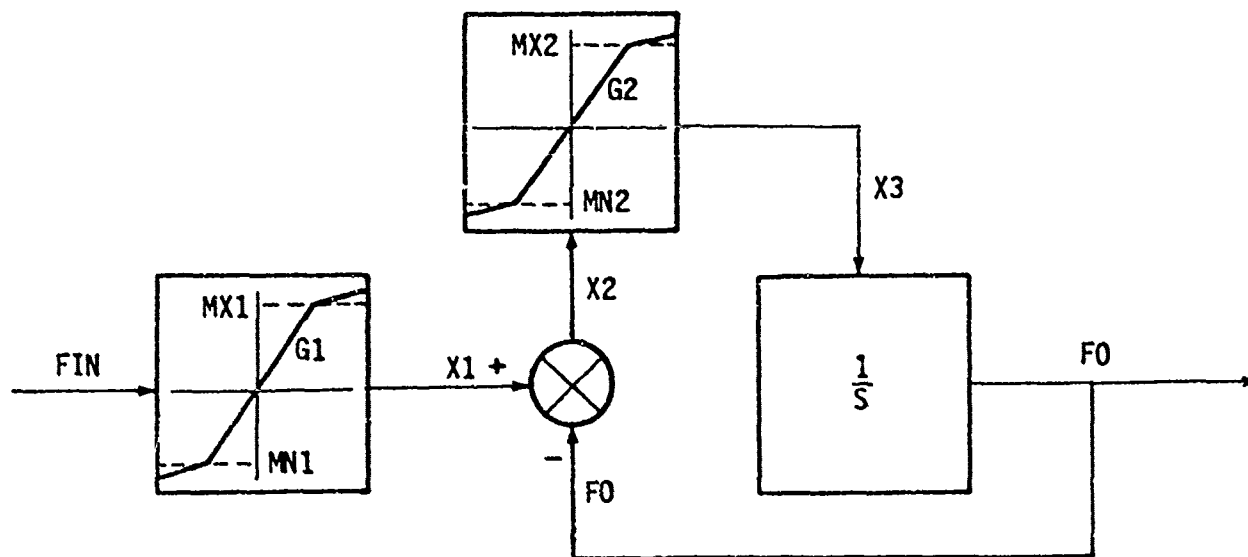

A flowchart for the subroutine is shown as Table 29 and Table 155 gives a detailed listing.

3.4.9 Subroutine AP

The purpose of subroutine AP is to simulate JINDIVIK autopilot for pitch control and is therefore a special purpose subroutine. The pitch autopilot function is

$$\eta_d = .28 (\dot{\theta} - \dot{\theta}_d) + .533 (\theta - \theta_d) \quad 3.4-11$$

where η_d = elevator angle

$\dot{\theta}$ = pitch rate

$\dot{\theta}_d$ = pitch reference rate

θ = pitch angle

θ_d = pitch reference angle

The elevator servo transfer function is

$$\frac{\eta}{\eta_d} = \frac{1 + .32s}{(1 + .4s)(1 + .11s + .0063 s^2)} \quad 3.4-12$$

where s is the Laplace transform operator.

A flowchart for the subroutine is shown in Table 6 and Table 132 gives a detailed listing.

3.4.10 Subroutine AR

The purpose of subroutine AR is to simulate JINDIVIK autopilot for roll control and is only a special purpose subroutine.

The lateral autopilot function is

$$\zeta_d = 0.196 (\dot{\phi} - \dot{\phi}_d) + .42 (\phi - \phi_d) + .2R + K_r \int R dt + .0082 \int \int R dt \quad 3.4-13$$

where ζ_d = aileron angle commanded

$\dot{\phi}$ = roll rate

$\dot{\phi}_d$ = roll reference rate (10deg/sec)

ϕ = roll angle

ϕ_d = roll reference angle

R = yaw rate

K_r = 0.35 for flight and approach

K_r = 0 after touchdown ($t=0$)

$$\frac{\xi}{\xi_d} = \frac{1 + .32 s}{(1+.4S)(1+.11S+.0063 s^2)}$$

3.4-14

where s is the Laplace transform operator.

A flowchart for the subroutine is shown in Table 7 and Table 133 gives a detailed listing.

3.4.11 Subroutine IT

The purpose of subroutine IT is to simulate an integrator with limits on the upper and lower limits of the output. Table 54 shows a flowchart of the subroutine and Table 180 gives a detailed listing which includes the full input/output list. The values of AMA, AMI and GKL can be selected using the same logic described in Reference 2, Volume II, Section 3.4-10.

3.5 Miscellaneous Subroutines

3.5.1 Subroutine SW

The purpose of subroutine SW is to provide the capability to switch the value of a variable during the course of a simulation. The subroutine output (VO1) is initially set equal to one or other of the input variables (VA1 and VB1), depending on the initial value of the switch control (SW1). At time TC1 the output variable is switched, and at time TC2 (with TC2 greater than TC1) the output variable is switched back.

The subroutine may be used to provide forcing function inputs such as step changes or impulses, to the boundary conditions of a system, as shown in Figure 7(a) and 7(b). (Arbitrary time dependent inputs can be obtained from subroutines TA and TB described in Sections 3.5.5 and 3.5.6 respectively). The subroutine can also be used to change the value of an input parameter of a component. For example, the K factor of a duct could be changed during a simulation in order to determine the effect of a partial flow blockage; this

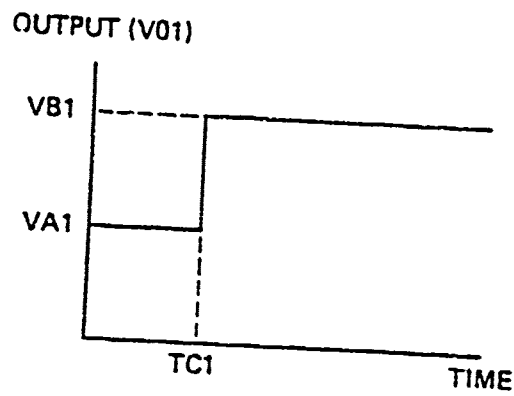

Figure 7 (a) Step Function

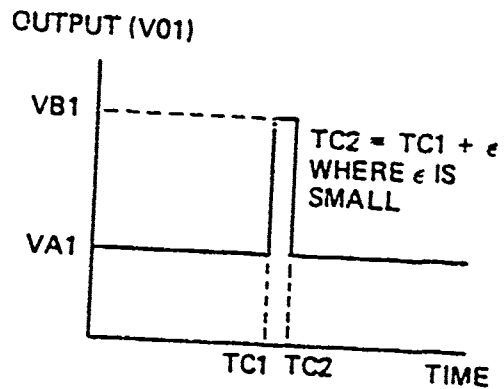

Figure 7 (b) Impulse Function

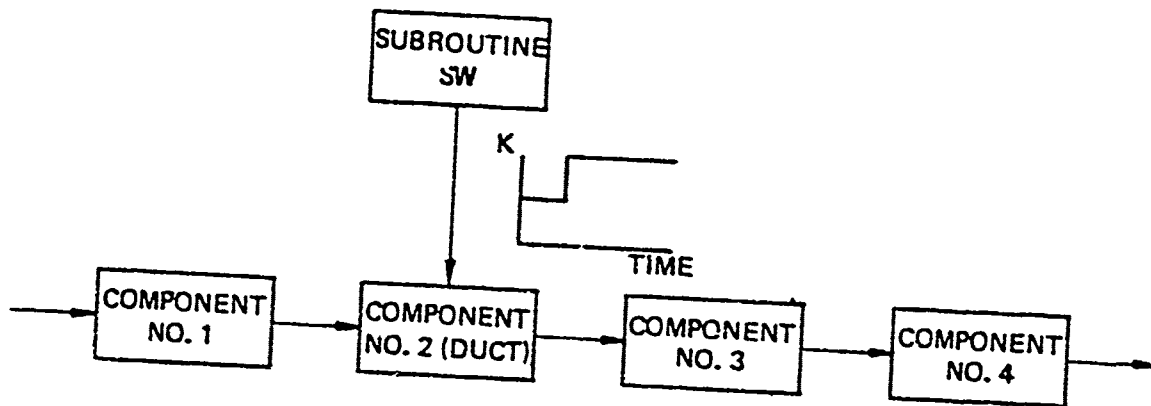

Figure 7 (c) Parameter Changes

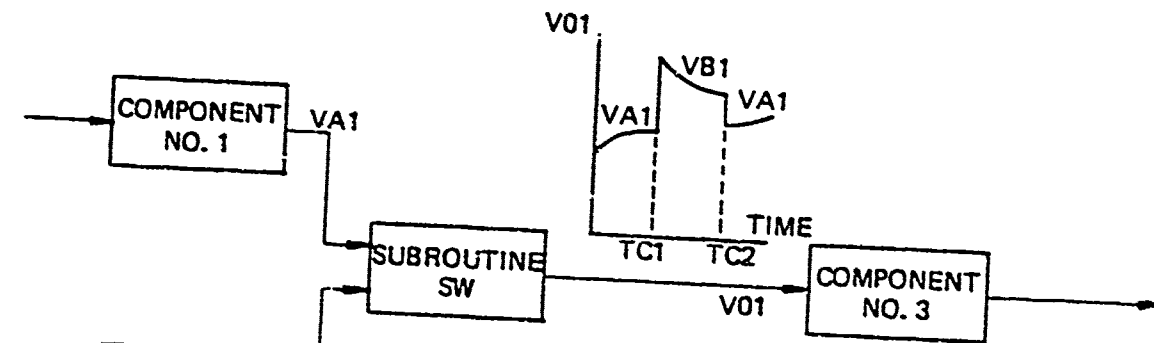

Figure 7 (d) Output Switching

Figure 7 Application of Switch Subroutine SW

is illustrated in Figure 7(c). Also the subroutine can be used to switch the output signals from two separate components as inputs into a single component, (Figure 7(d)).

A flowchart for the subroutine is shown as Table 94 and Table 220 gives a detailed listing which includes the full input/output list.

3.5.2 Subroutine SX

The purpose of subroutine SX is to provide the capability to switch the values of two variables during the course of a simulation. The subroutine is very similar to SW (described in Section 3.5.1) except that there are two outputs (V01 and V02), with two inputs for each output (VA1 and VB1 for V01, VA2 and VB2 for V02). The outputs are both switched at time TC1 and then switched back at time TC2 (with TC2 greater than TC1). Possible applications of subroutine SX are as discussed in Section 3.5.1 and illustrated in Figure 7.

The flowchart for the subroutine is shown as Table 95 and Table 221 gives a detailed listing which includes the full input/output list.

3.5.3 Subroutine SY

The purpose of subroutine SY is to provide the capability to switch the values of three variables during the course of a simulation. The subroutine is very similar to SW (described in Section 3.5.1), except that there are three outputs (V01, V02, and V03) with two inputs for each output (VA1 and VB1 for V01, VA2 and VB2 for V02, and VA3 and VB3 for V03). The outputs are all switched at time TC1 and then switched back at time TC2 (with TC2 greater than TC1). Possible applications of subroutine SY are discussed in Section 3.5.1 and illustrated in Figure 7.

The flowchart for the subroutine is shown as Table 96 Table 222 gives a detailed listing which includes the full input/output list.

3.5.4 Subroutine SZ

The purpose of subroutine SZ is to provide the capability to switch the values of four variables during the course of a simulation. The subroutine is very similar to the SX (as described in Section 3.5.1) except that there are four outputs (V01, V02, V03, and V04) with two inputs for each output (VA1 and VB1 for V01, VA2 and VB2 for V02, VA3 and VB3 for V03, and VA4 and VB4 for V04). The outputs are all switched at time TC1 and then switched back at time TC2 (with TC2 greater than TC1). Possible applications of subroutine SZ are as discussed in Section 3.5.1 and illustrated in Figure 7.

The flowchart for the subroutine is shown as Table 97. Table 223 gives a detailed listing which includes the full input/output list.

3.5.5 Subroutine TA

The purpose of subroutine TA is to provide the capability to input up to four variables as functions of time. Inputs to the subroutine are four one-dimensional tables (A2TAB, B2TAB, C2TAB, and D2TAB) with time as the independent variable. The corresponding outputs are the variables A2, B2, C2, and D2.

The value of time is obtained within the subroutine from the common block CTIME.

A typical application of the subroutine would be to calculate engine bleed and fan air pressures and temperature during a throttle burst or chop. Alternatively it can be used to input other time dependent variables such as electrical heat loads. Step changes or impulses can be input more efficiently using the "switch" subroutines SW, SX, SY and SZ (Sections 3.5.1 through 3.5.4). Subroutine TA should be used where there are four or three time dependent inputs (in the latter instance one table is a dummy); for two or one time dependent inputs, subroutine TB (Section 3.5.6) is more appropriate.

A flowchart for the subroutine is shown as Table 100 and Table 226 gives a detailed listing which includes the full input/output list.

3.5.6 Subroutine TB

The purpose of subroutine TB is to input up to two variables as a function of time. Inputs to the subroutine are two one-dimensional tables (A2TAB and B2TAB) with time as the independent variable. The corresponding outputs are the variable A2 and B2. The value of time is obtained within the subroutine from the common block CTIME.

This subroutine is very similar to TA (Section 3.5.5) except that it is limited to two input tables and corresponding outputs, whereas TA has the capability of up to four input tables. Typical applications of both TA and TB are discussed in Section 3.5.5.

The flowchart for the subroutine is shown as Table 101. Table 227 gives a detailed listing for subroutine TB, including the full input/output list.

3.5.7 Subroutine AF

The purpose of subroutine AF is to generate several analytical functions, with time as the independent variable. The output from the subroutine can be used as an input to a system in order to determine the system response to the particular form of excitation. The analytical function is selected by an input code as follows:

COD =	OUTPUT =	
1	$C_1 + C_2 \text{ Sin } (C_3 t + C_4).$	
2	$C_1 + C_2 \text{ Cos } (C_3 t + C_4).$	
3	$C_1 + C_2 e^{-C_5 t} \text{ Sin } (C_3 t + C_4).$	
4	$C_1 + C_2 e^{-C_5 t} \text{ Cos } (C_3 t + C_4).$	3.5-1
5	$C_1 + C_2 t$	
6	$C_1 + C_2 e^{-C_3 t}$	

where $C_1, C_2, C_3, C_4,$ and C_5 are constants and t is time.

Table 4 shows a flowchart for the subroutine, and Table 130 gives a detailed listing which includes the full input/output list.

3.5.8 Subroutine MA

The purpose of subroutine MA is to reset the value of a variable according to the equation

$$FO = C1 \times FIN + C2 \quad 3.5-2$$

where FO is the output
 FIN is the input
 and $C1, C2$ are input constants

A typical application for subroutine MA would be to simulate a symmetrical flow merge, for example where the flow from two engine bleed systems merge to flow into a single air conditioning pack. For such a case FIN would be the flow from a single engine, FO would be the pack flow, $C1$ would be set equal to 2 and $C2$ to zero.

Table 60 shows a flowchart for the subroutine and Table 186 gives a detailed listing which includes the full input/output list.

3.5.9 Subroutine FU

The purpose of subroutine FU is to provide the capability of simulating an arbitrary one-dimensional table $y = f(X)$. The user has the capability of specifying the degree of interpolation and whether or not extrapolation should be permitted.

Table 43 shows a flowchart for the subroutine and Table 169 gives a detailed listing which includes the full input/output list.

3.5.10 Subroutine MC

The purpose of subroutine MC is to reset the value of a variable according to the equations

$$F0 = C1 \times FIN + C2 \times FIO + C3 \times FIP + C4 \quad 3.5-3$$

where F0 is the output

FIN, FIO, FIP are inlet variables

and C1, C2, C3 and C4 are input constants.

A typical application for MC would be to simulate a summation of several variables in a control loop. Table 62 shows a flowchart for the subroutine and Table 188 shows a detailed listing which includes the full input/output list.

3.5.11 Subroutine SA

The purpose of subroutine SA is to simulate a saturation. A typical application would be to limit the output from a controller to within prescribed values. The use of zero slopes in the saturation region should be avoided if possible, since the severe non-linearity will slow down the steady state solver.

Table 82 shows a flowchart for the subroutine and Table 208 gives a detailed listing which includes the full input/output list.

3.5.12 Subroutine SB

The purpose of subroutine SB is to provide the capability of simulating a saturation function with a dead band.

Table 83 shows a flowchart for the subroutine and Table 209 gives a detailed listing which includes the full input/output list.

3.5.13 Subroutine MB

The purpose of subroutine MB is to calculate the value of a variable according to the equation

$$FO = C1 * FNA + C2 * FNB + C3 * FNA * FNB \\ + C4 * FNA / FNB + C5$$

3.5-4

where FO is the output,

FNA and FNB are input variables, and

C1, C2, C3, C4, and C5 are input constants.

Table 61 shows a flowchart for the subroutine and Table 187 gives a detailed listing which includes the full input/output list.

3.5.14 Subroutine FV

The purpose of subroutine FV is to provide the capability of simulating an arbitrary two-dimensional table $Z=f(X,Y)$. The user has the capability of specifying the degree of interpolation and whether or not extrapolation should be permitted.

Table 44 shows a flowchart for the subroutine and Table 170 gives a detailed listing which includes the full input/output list.

3.5.15 Subroutine RA

The purpose of subroutine RA is to generate random variables for the gust wind model GW. Discrete random variables with mean zero and variance equal to twice the time increment approximates a unit variance white noise. RA can only be used with the fixed step integrator which is specified by the command:

INT MODE = 3. A flowchart of the subroutine is shown as Table 75 and Table 201 gives a detailed listing.

3.5.16 Subroutine RN

The purpose of subroutine RN is to generate a normally distributed random number. This subroutine is called by the subroutine RA.

A flowchart of the subroutine is shown as Table 79 and Table 205 gives a detailed listing.

3.5.17 Subroutine S2

The purpose of subroutine S2 is to sum two sets of 3 axis forces and moments and is thus a summing junction. The two sets of forces must be in the same axis i.e. body, stability, or wind.

A flowchart of the subroutine is shown as Table 98 and Table 224 gives a detailed listing.

3.5.18 Subroutine S3

The purpose of subroutine S3 is to sum three sets of 3 axis forces and moments and is also a summing junction. A flowchart of the subroutine is shown as Table 99 and Table 225 gives a detailed listing.

3.5.19 Subroutine TG

The purpose of subroutine TG is to transform engine thrust into body axis forces and moments (torques) by using user provided direction cosines and moment arms.

A flowchart for the subroutine is shown as Table 110 and Table 236 gives a detailed listing.

3.5.20 Subroutine TR

The purpose of subroutine TR is to transform a set of vector quantities from body axes to earth axes using roll, pitch, yaw angle inputs and direct multiplication method.

A flowchart for the subroutine is shown as Table 113 and Table 239 gives a detailed listing.

3.5.21 Subroutine XP

The purpose of subroutine XP is to perform static transformation on three vector quantities (angular rates) from one coordinate system to another coordinate system using a matrix transformation technique.

A flowchart for the subroutine is shown as Table 124 and Table 250 gives a detailed listing.

3.5.22 Subroutine XT

The purpose of subroutine XT is to perform static transformation on three vector quantities (torques) from one coordinate system to another coordinate system using a matrix transformation technique.

A flowchart for the subroutine is shown as Table 125 and Table 251 gives a detailed listing.

3.6 Table Lookup Functions

3.6.1 Function TBL1

The purpose of function TBL1 is to perform linear interpolation on one independent variable. It is a special purpose function as it is called only by subroutine TK to interpolate the trunk shape parameters.

A flowchart for the function is shown as Table 102 and Table 228 gives a detailed listing.

3.6.2 Function TBL2

The purpose of function TBL2 is to perform curvilinear-to-rectilinear transformation and to linearly interpolate on two independent variables. This is also a special purpose function as it is called only by subroutines TK and AB to interpolate the trunk/bag shape parameters.

A flowchart for the function is shown Table 103 and Table 229 gives a detailed listing.

3.6.3 Function TBLU1

The purpose of function TBLU1 is to perform table search and Lagrangian polynomial interpolation on one independent variable. The function uses a binary search technique to locate the proper position within a table, and then uses a Lagrangian interpolating polynomial of user-defined degree.

A flowchart for the function is shown as Table 104 and Table 230 gives a detailed listing.

3.6.4 Function TBLU2

The purpose of function TBLU2 is to perform table search and Lagrangian polynomial interpolation of user-defined degree on two independent variables.

A flowchart for the function is shown as Table 105 and Table 231 gives a detailed listing.

3.6.5 Function TBLU3

The purpose of function TBLU3 is to perform table search and Lagrangian polynomial interpolation of user-defined degree on three independent variables.

A flowchart for the function is shown as Table 106 and Table 232 gives a detailed listing.

3.6.6 Subroutine ETB2

The purpose of subroutine ETB2 is to provide table look-up for a function of two independent variables $a = f(x,y)$. The subroutine was designed to support the elastic trunk component TS and utilizes equal increment data point spacing and linear interpolation.

A flowchart for the routine is shown as Table 26 and Table 152 gives a detailed listing.

3.6.7 Subroutine ETB3

The purpose of subroutine ETB3 is to provide table look-up for a function of three independent variables $a = f(x,y,z)$. The subroutine was designed to support the elastic trunk component TS and utilizes equal increment data point spacing and linear interpolation.

A flowchart for the routine is shown as Table 27 and Table 153 gives a detailed listing.

3.7 Initial Condition Function and Subroutines

3.7.1 Subroutine IC

The purpose of subroutine IC is to solve for trunk element parametric data for free and loaded ACLS trunk shapes at initial conditions. The concept is based on the so called Digges Parameter Calculations for an inelastic trunk (see AFFDL-TR-71-50, Theory of an ACLS for Aircraft by K. H. Digges, June 1971). It is a special purpose subroutine called only by component TK. The model can generate and store up to six sets of parameter data each representing an element of size and shape specified by the user. Each parameter set can be generated as a membrane model or a frozen model (see Volume I document). The trunk section properties are then evaluated from the stored arrays using table look-up routines (Section 3.6) during the model execution.

A flowchart of the subroutine is shown as Table 48 and Table 174 gives a detailed listing.

3.7.2 Subroutine ICB

The purpose of subroutine ICB is to solve for an air bag element parametric data for free and loaded air bag shapes at initial conditions. The function solves membrane geometry and force-balance equations for even increments of Z0 (the vertical distance between aircraft hard structure and bottom of the air bag) and MUT (the bag-runway interface friction) and stores parameter values for table look-up arrays. It is a special purpose subroutine called only by component AB.

A flowchart of the subroutine is shown as Table 49 and Table 175 gives a detailed listing.

3.7.3 Subroutine ICFS

The purpose of subroutine ICFS is to define initial condition free shape Digges model equations for an inelastic trunk. It is a special purpose subroutine and called only by the iterative equation solver routine QNWT in subroutine IC.

A flowchart of the subroutine is shown as Table 50 and Table 176 gives a detailed listing.

3.7.4 Subroutine ICFSB

The purpose of subroutine ICFSB is to evaluate geometry equations for a free shape air bag element. The equations used describe an inelastic membrane subject to uniform internal pressure. This subroutine is called only by QNWT in subroutine ICB.

A flowchart of the subroutine is shown as Table 51 and Table 177 gives a detailed listing.

3.7.5 Subroutine ICLS

The purpose of subroutine ICLS is to define initial condition loaded shape Digges model equations for an inelastic trunk. Like ICFS it is called only by QNWT in subroutine IC.

A flowchart of the subroutine is shown as Table 52 and Table 178 gives a detailed listing.

3.7.6 Subroutine ICLSB

The purpose of subroutine ICLSB is to evaluate element geometry and force balance equations for loaded shape air bag element. Equations describe an inelastic membrane subject to uniform internal pressure and ground reaction forces. Like ICFSB, this subroutine is called only by QNWT in subroutine ICB.

A flowchart of the subroutine is shown as Table 53 and Table 179 gives a detailed listing.

3.7.7 Subroutine KINK

The purpose of subroutine KINK is to calculate the arresting gear cable kink wave angle at landing impact. This is a special purpose subroutine called only by the arresting gear component AS.

A flowchart of the subroutine is shown as Table 55 and Table 181 gives a detailed listing.

3.7.8 Subroutine RES

The purpose of subroutine RES is to evaluate the arresting cable strain. This is also a special purpose subroutine called only by subroutine KINK.

A flowchart of the subroutine is shown as Table 77 and Table 203 gives a detailed listing.

3.7.9 Function TERRA

The purpose of function TERRA is to simulate a rough terrain with random profile or a sinusoidal and (1-cosine) bump profiles. For random profiles the vertical elevation is stored in tabular form as a function of position.

A flowchart of the subroutine is shown as Table 108 and Table 234 gives a detailed listing.

3.7.10 Subroutine VPRINB

The purpose of subroutine VPRINB is to print, as output, the user supplied input data arrays for the air bag element dimensions, perforations etc., the various stored arrays calculated in the initial condition routine ICB, and element geometry and forces calculated during execution/simulation as a function of time.

A flowchart of the subroutine is shown as Table 121 and Table 247 gives a detailed listing.

3.7.11 Subroutine VPRINT

The purpose of subroutine is to print, as output, the user supplied input data arrays for the trunk element dimensions, perforations, scaling factors etc., the various stored arrays calculated in the initial condition routine IC, and element geometry and forces calculated as time-history functions.

A flowchart of the subroutine is shown as Table 122 and Table 248 gives a detailed listing.

3.7.12 Subroutine ELAS

Subroutine ELAS computes the data arrays for elastic trunk component TS. Subroutines ENDFS, ENDLS, SIDEFS and SIDELS are called by QNWT to determine trunk cross-sectional shapes. Data arrays are then filled with computed trunk variables.

A flowchart for the routine is shown as Table 19 and Table 145 gives a detailed listing.

3.7.13 Subroutine ELFX

Subroutine ELFX computes incomplete elliptic integrals of the second kind $E(\theta, \phi)$. The subroutine was designed for use by the elastic trunk component (TS) to compute arc lengths for ellipses. If θ or ϕ are less than zero, the routine will return $E = 0$.

A flowchart for the routine is shown as Table 20 and Table 146 gives a detailed listing.

3.7.14 Subroutine ELKX

Subroutine ELKX computes complete elliptic integrals of the second kind $E(\theta, \pi/2)$. The subroutine was designed for use by the elastic trunk component (TS) to compute arc lengths for ellipses. If θ is less than zero, the routine will return $E = 0$.

A flowchart for the routine is shown as Table 21 and Table 147 gives a detailed listing.

3.7.15 Subroutine ELWR

Subroutine ELWR supports the elastic trunk component (TS) to provide printout of the trunk element property arrays.

A flowchart for the routine is shown as Table 22 and Table 148 gives a detailed listing.

3.7.16 Subroutine ENDFS

This subroutine is used by elastic trunk component TS to compute the free shape of a trunk end element. The trunk cross-section is assumed to be elliptical in shape and in point contact with the ground. The shape equations incorporate membrane theory and consider elastic deformation in the trunk hoop and meridian directions.

A flowchart for the routine is shown as Table 23 and Table 149 gives a detailed listing.

3.7.17 Subroutine ENDLS

This subroutine is used by elastic trunk component TS to compute the loaded shape of a trunk end element. The trunk cross-section is assumed to be comprised of elliptical arcs (2), one on each side of a straight section which is in ground contact. As in ENDFS, the shape equations incorporate membrane theory and consider elastic deformation in the hoop and meridian directions.

A flowchart for the routine is shown as Table 24 and Table 150 gives a detailed listing.

3.7.18 Subroutine SIDEFS

This subroutine is used by elastic trunk component TS to compute the free shape of a trunk side element. The trunk cross-section is represented by circular arcs and is assumed to be in point contact with the ground. The shape equations incorporate membrane theory and consider elastic deformation in the meridian direction only.

A flowchart for the routine is shown as Table 89 and Table 215 gives a detailed listing.

3.7.19 Subroutine SIDEELS

This subroutine is used by elastic trunk component TS to compute the loaded shape of a trunk side element. The trunk cross-section is represented by two circular arcs, one on each side of a straight section which is in ground contact.

A flowchart for the routine is shown as Table 90 and Table 216 gives a detailed listing.

3.7.20 Subroutine XXPRT

This routine is used by elastic trunk component TS to provide printed output of trunk variables during non-linear simulation.

A flowchart for the routine is shown as Table 126 and Table 252 gives a detailed listing.

3.8 Supporting Subroutines for the Foster-Miller Trunk Component (FM)

Of the twenty subroutines which make up this section, eighteen were written by Foster-Miller Associates Inc., (FMA) as part of their model for an air cushion landing system (ACLS). The remaining two subroutines (FMWRIT and OUTFM) were developed by the Boeing Company to replace FMA input/output routines which were incompatible with the EASY program.

3.8.1 Subroutine CDVCHP

This subroutine calculates the value of DVCHP which is the ratio of cushion volume change to change in cushion-to-trunk pressure ratio.

A flowchart for the routine is shown as Table 10 and Table 136 gives a detailed listing.

3.8.2 Subroutine CLRNCE

The purpose of this subroutine is to calculate the trunk-ground clearance for each trunk segment.

A flowchart for the subroutine is shown as Table 9 and Table 135 gives a detailed listing.

3.8.3 Subroutine COORDN

This subroutine calculates the X and Z coordinates of the ground point corresponding to each segment, for a particular ACLS orientation.

A flowchart for the routine is shown as Table 11 and Table 137 gives a detailed listing.

3.8.4 Subroutine DYNFAN

This subroutine models the dynamic behavior of the ACLS fan. Fan pressure is calculated from a user defined polynomial function of fan flow.

A flowchart for the routine is shown as Table 16 and Table 142 gives a detailed listing.

3.8.5 Subroutine FLOW

This subroutine calculates the ACLS flow and pressure variables during dynamic simulation.

A flowchart for the routine is shown as Table 32 and Table 158 gives a detailed listing.

3.8.6 Subroutine FMFAN

This subroutine models the static behavior of the ACLS fan. Fan flow is calculated from a user defined polynomial function of fan pressure.

A flowchart for the routine is shown as Table 34 and Table 160 gives a detailed listing.

3.8.7 Subroutine FMWRIT

This subroutine was developed by the Boeing Company to print a list which describes each ACLS input variable and the corresponding value input by the user.

A flowchart for the routine is shown as Table 35 and Table 161 gives a detailed listing.

3.8.8 Subroutine FORCE

This subroutine calculates the forces and torques associated with a particular ACLS orientation.

A flowchart for the routine is shown as Table 38 and Table 164 gives a detailed listing.

3.8.9 Subroutine HYCURV

This subroutine calculates the side trunk height as a function of pressure ratio.

A flowchart for the routine is shown as Table 47 and Table 173 gives a detailed listing.

3.8.10 Subroutine OUTFM

This subroutine was developed by the Boeing Company and replaces FMA routine OUTPUT. The purpose of the routine is to calculate various time dependent variables during ACLS dynamic simulation.

A flowchart for the routine is shown as Table 67 and Table 193 gives a detailed listing.

3.8.11 Subroutine PARAMS

This subroutine provides default values for various ACLS parameters. The user may override these default values by inputting the desired values.

A flowchart for the routine is shown as Table 68 and Table 194 gives a detailed listing.

3.8.12 Subroutine PROFILE

This user-supplied subroutine provides values of ground elevation $Yg(i)$ which correspond to ground coordinates $Xg(i)$ and $Zg(i)$. A default subroutine is included in the ACLS library to simulate a flat ground surface. The user may input a different PROFILE using Fortran statements in the model description data file.

A flowchart for the routine is shown as Table 72 and Table 198 gives a detailed listing.

3.8.13 Subroutine ROTATE

This subroutine transforms vector data from the vehicle frame to the inertial reference frame.

A flowchart for the routine is shown as Table 80 and Table 206 gives a detailed listing.

3.8.14 Subroutine SEGMNT

This subroutine divides the ACLS trunk into a number of segments and assigns initial properties to the segments.

A flowchart for the routine is shown as Table 84 and Table 210 gives a detailed listing.

3.8.15 Subroutine SHAPE1

This subroutine provides an initial assessment of ACLS trunk areas and volumes assuming no ground contact.

A flowchart for the routine is shown as Table 86 and Table 212 gives a detailed listing.

3.8.16 Subroutine SHAPL

This subroutine calculates current ACLS trunk areas and volumes as a function of vehicle orientation.

A flowchart for the routine is shown as Table 87 and Table 213 gives a detailed listing.

3.8.17 Subroutine STATIC

This subroutine provides static simulation of an ACLS. Equilibrium conditions are calculated and include the position of the aircraft center of gravity; orientation of the aircraft in terms of pitch and roll angles; equilibrium pressure in the trunk, cushion and plenum; equilibrium flows in different parts of the ACLS and the theoretical power required to operate the ACLS.

The static simulation also generates load maps which are useful in evaluating behavior of the ACLS in pure heave (up-down), pitch and roll modes.

A flowchart for the routine is shown as Table 91 and Table 217 gives a detailed listing.

3.8.18 Subroutine STEQU

Subroutine STEQU calculates the time derivatives for the set of ACLS state variables. The routine calls subroutine FLOW and FORCE to update the values of flows, forces and torques associated with the current set of state variables.

A flowchart for the routine is shown as Table 92 and Table 218 gives a detailed listing.

3.8.19 Subroutine TRUNK

This routine calculates the values of variables associated with the ACLS trunk cross section shape.

A flowchart for the routine is shown as Table 114 and Table 240 gives a detailed listing.

3.8.20 Subroutine VALVE

This subroutine calculates the pressure relief valve area as a function of valve displacement.

A flowchart for the routine is shown as Table 119 and Table 245 gives a detailed listing.

SECTION IV
COMPONENT SUBROUTINES

4.1 Ducting Components

The component subroutines covered in this section include ducts (DU), splits (FS) and merges (MG).

It should be noted that it is possible and often desirable to represent ducting components in other ways. For example, the flow merge between two bleed air systems could be simulated using the merge component MG as shown in Figure 8(a). However if only one of the bleed systems is being modeled in detail, and if the flow from each bleed system is assumed equal, then it would be preferable to use the multiply-and-add standard subroutine MA (see Section 3.5.8) as shown in Figure 8(b). The advantage of using MA in this instance is that less input data is required, and one less state variable would be required. Component MA can of course also be used to simulate a flow split. Ducts can often be omitted, with pressure, temperature, and flow capacitance effects being "lumped-in" with other components.

The detailed models for ducts, splits and merges should be used where the high frequency flow dynamics effects are considered significant; otherwise alternates should be used as described above.

4.1.1 Duct DU

The duct component DU is a simple single-state model in which the only dynamic effect simulated is flow capacitance, with pressure being a state variable. The theory for the model is given in Reference 2, Volume I, Section 3.1.1, which also describes the theory for more complex models which can be supplied by the program user if desired.

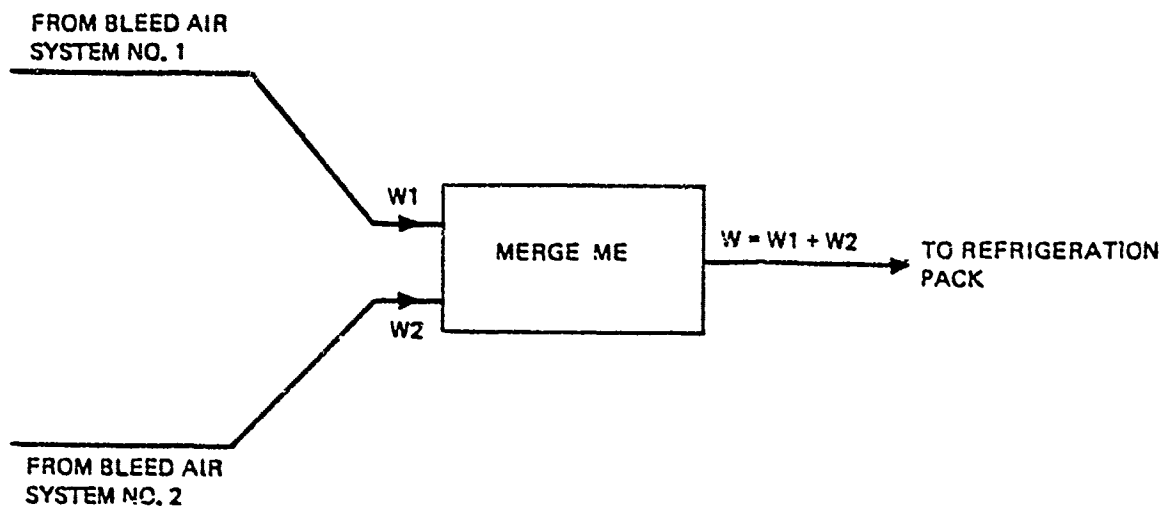

(a) FLOW MERGE USING COMPONENT ME

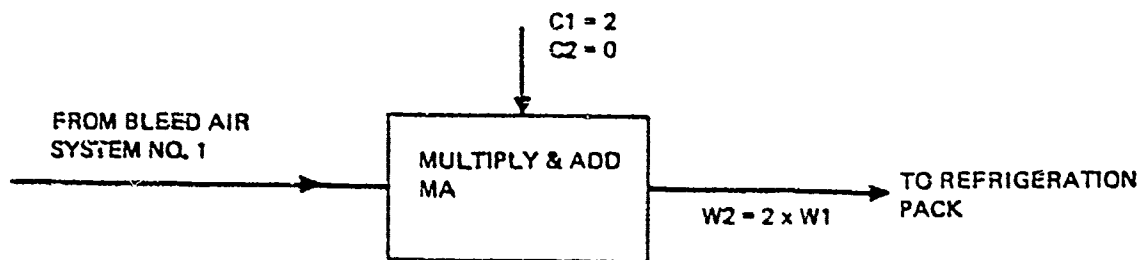

(b) FLOW MERGE USING COMPONENT MA

Figure 8 Alternate Representations of Flow Merge

A flowchart for the subroutine is shown as Table 14 and Table 140 gives a detailed listing which includes the full input/output list. A warning message will be printed in the event that the temperature change exceeds 300°F, since in this event a more complex model with temperature nodes in the wall and possibly also in the fluid may be desirable.

4.1.2 Split FS

The split component FS models a flow divide, and has a single inlet port and two outlet ports. The basic approach is very similar to that of the duct component DU. The flow in each outlet leg is calculated based on input values of K factor and effective area for each leg. Heat transfer is calculated based on an input value of hydraulic diameter (for calculation of Reynolds number) and heat transfer area. The theory for the Split model is given in Reference 2, Volume I, Section 3.1.2.

A flowchart for the subroutine is shown as Table 40 and Table 166 gives a detailed listing which includes the full input/output list. A warning diagnostic will be printed in the event that the temperature change exceeds 300°F, since in this event a more complex model with temperature nodes in the wall and possibly also in the fluid may be desirable.

4.1.3 Merge MG

The merge component MG models a flow junction, and has two inlet ports and a single outlet port. The basic approach is very similar to that of the duct component DU. The flow in the outlet leg is calculated based on input values of K factor and effective area for that leg. Heat transfer is calculated based on an input value of hydraulic diameter (for calculation of Reynolds number) and heat transfer area. The theory for the merge model is given in Reference 2, Volume I, Section 3.1.3.

A flowchart for the subroutine is shown as Table 63 and Table 189 gives a detailed listing which includes the full input/output list. A warning diagnostic will be printed in the event that the temperature change exceeds 300°F , since in this event a more complex model with temperature nodes in the wall and possibly also in the fluid may be desirable.

4.1.4 Valve In a Duct DV

The "valve in a duct" component DV simulates a valve (butterfly, gate or globe) in a duct. The basic approach is similar to the duct component DU, except that the flow is calculated by calling the subroutine VLX. Inputs to DV include a parameter defining the type of valve, and the valve opening. The theory for the flow calculation is given in Reference 2, Volume I, Section 3.7.

A flowchart for the subroutine is shown as Table 15 and Table 141 gives a detailed listing which includes the full input/output list. A warning diagnostic will be printed in the event that the temperature change exceeds 300°F , since in this event a more complex model with temperature nodes in the wall and possibly also in the fluid may be desirable.

4.2 Fan and Ejector Components

4.2.1 Ejector EJ

The purpose of the component EJ is to model an air ejector with converging-diverging nozzle and subsonic or choked flow conditions. The subroutine uses a two dimensional input table of flow ratio (total/primary) as a function of the two pressure ratios (total/secondary) and (primary/secondary). For choked throat flow upstream pressure is computed to match flow and for subsonic flow the exit pressure equals secondary supply pressure. A flowchart for the subroutine is shown as Table 18 and Table 144 gives a detailed listing.

4.2.2 Fan with Hysteresis FH

The purpose of the component FH is to model an externally driven axial fan with transition time constant between stall and recovery. It is assumed that transition from normal to stalled operation occurs when the pressure ratio exceeds the stall pressure ratio (user supplied) and that transition from stalled to normal occurs when pressure ratio falls below a reverse pressure ratio (user supplied).

A flowchart for the component is shown as Table 30 and Table 156 gives a detailed listing.

4.2.3 Fan with Surge Analysis FR

The compressor/fan model FR calculates the component performance using steady state maps. Inlet pressure is the one state variable for the model.

The model is capable of reverse flow analysis and can accommodate pressure ratios less than 1. The theory for the model is shown in Reference 2, Volume I, Section 3.2.2.

A flowchart for the subroutine is shown as Table 39 and Table 165 gives a detailed listing which includes the full input/output lists.

4.2.4 ACLS Turbofan FT

The purpose of fan component FT is to simulate a hub or tip driven axial turbofan as used on the Jindivik ACLS vehicle. The subroutine uses input table defining steady state characteristics of turbine and fan. Drive air turbine inlet pressure is a state variable.

A flowchart for the subroutine is shown as Table 42 and Table 168 gives a detailed listing.

4.2.5 Inlet Fan FN

The purpose of this component is to model a fan which is located at the inlet of a duct. It calculates the fan's flow rate, inlet pressure, inlet temperature and outlet temperature. The flow rate is determined from tabular data which is input as a function of pressure ratio (PR) and fan RPM. If this flow rate data has been normalized for $\sqrt{\theta/\delta}$, where θ is the air temperature divided by the air temperature at sea level on a standard day and δ is the air pressure divided by the air pressure at sea level on a standard day. FN will account for this normalization if CORFN is set to any value except 0.0 and .99999. The inlet pressure and temperature are determined by the inlet ram efficiency. The outlet temperature is calculated from the fan efficiency.

The user has the option of inputting stall line data as a function of pressure ratio. When this data is input, the program will print after each print cycle "The fan is operating in the stall region" whenever the fan is stalled.

A flowchart for the subroutine is shown in Table 36 and Table 162 gives a detailed listing which includes the full input/output lists.

4.3 Aircraft and Aerodynamic Components

4.3.1 Generalized 6DOF Component SG

The six degree of freedom component SG simulates the aircraft rigid body of motion equations. The component receives as input all body axis forces and moments including gravity. Parametric inputs include mass, and moments and cross products of inertia of the aircraft. Outputs from the component include the accelerations and velocities (linear and angular) in the body axis coordinate system, Euler angles and earth axis positions. The differential equations for the twelve states representing the linear and angular velocities and positions are contained in this component. The derivation of equations is described in Section 2.4.1, Volume I. Table 85 shows a flowchart and Table 211 gives a detailed listing.

4.3.2 Six DOF Component DS

This component is same as the component SG except that the X-Z plane is assumed to be a plane of symmetry. Therefore the cross product of inertia terms I_{xy} and I_{yz} and associated terms are taken out simplifying the equations of motion. In addition the airplane positions in X and Y earth axis are not state variables and only rates (velocities) are output. It is recommended that this component be used for inflight models when there are no trunk or ACLS components involved and the optimal controller is being used for finding trim.

A flowchart for the component is shown as Table 13 and Table 139 gives a detailed listing.

4.3.3 4DOF Rigid Body Dynamics FD

The four degree of freedom component consists of the same types of inputs and outputs and uses the same coordinate system as the 6DOF component DS. The degrees of freedom are forward and side velocities and roll and yaw (U,V,P,R) and the model is applicable to ground directional control studies. Table 28 shows a flowchart and Table 154 gives a detailed listing.

4.3.4 3DOF Longitudinal Rigid Body Dynamics TL

This is a simplified version of the six DOF component DS where only longitudinal equations of motion are treated. The degrees of freedom are forward and vertical velocities, and pitch (U,W,Q). The model is applicable to long period longitudinal stability analysis (Phugoid). Table 112 shows a flowchart and Table 238 gives a detailed listing.

4.3.5 3DOF Lateral Rigid Body Dynamics TD

This is also a simplified version of the six DOF component DS where only lateral equations of motion are retained. The degrees of freedom are side velocity, roll and yaw (V,P,R). The model is applicable to lateral stability analysis. Table 107 shows a flowchart and Table 233 gives a detailed listing.

4.3.6 2DOF Longitudinal Rigid Body Dynamics TT

This component is similar to the component TL, above, except that the degrees of freedom are vertical velocity (or heave) and pitch (W,Q). The model is applicable to drop test simulations and for inflight short period longitudinal oscillations. Table 116 shows a flowchart for the subroutine and Table 242 gives a detailed listing.

4.3.7 Aerodynamic Variables Component VA

The model adds total wind perturbation onto the aircraft velocity states, output from 6DOF component, and computes aero variables such as angle-of-attack, sideslip, dynamic pressure, and Mach number. The body to stability axis transformation is achieved wherever applicable. A switch is used to assure compatibility with various DOF components. The derivation of equations is described in Section 2.4.7, Volume I. Table 118 shows a flowchart and Table 244 gives a detailed listing.

4.3.8 Longitudinal forces and Moments Component OL

Inputs to this component include external forces and torques (e.g. due to trunk, engine) and aerostability derivatives for the three longitudinal degrees of freedom. The external forces and moments are combined with the linear aero forces and moments in body axes and output as total force and moment vectors about the aircraft c.g. The module also solves for the linear accelerations U and W in order to compute the implicit aero terms due to $\dot{\alpha}$ and $\dot{\beta}$. The body axis linear accelerations and the torques are then passed to the equations of motion module DS or SG.

The aero derivatives can be specified in either stability axes or in body axes. For more details see Section 5.1 of the User's Manual (Reference 1) and Volume I, Section 2.4.8. A flowchart for the component OL is shown as Table 65 and Table 191 gives a detailed listing.

4.3.9 Lateral Forces and Moments Component DL

This component is identical in design to component OL and computes the lateral set of forces and moments. A flowchart for the component is shown as Table 12 and Table 138 gives a detailed listing.

4.3.10 Aerodynamic Coefficients Table Lookup AC

This component provides for one dimensional table lookup capability for the six basic aerodynamic coefficients; lift, drag, pitch moment, roll moment and yaw moment as functions of angle of attack (α) and the side force coefficient as a function of angle of side slip (β). The user should carefully read the code before using this component or use FORTRAN to input tabular data for the various non-linear aero coefficients. A flowchart for the subroutine is shown as Table 3 and Table 129 gives a detailed listing.

4.4 Engine and Thruster Components

4.4.1 Engine Model (Simple) ES

See 4.4.2 for description.

4.4.2 Engine Model (Complex) EC

Two engine components were developed. Both calculate engine thrust and engine bleed-and-fan-air pressures and temperatures. The model ES is dynamically simple, with all dynamic effects accounted for by a first order lag for the thrust calculation.

In the second, more complex model, EC, the engine pressure ratio (EPR) is computed as a function of the power lever angle. Engine transient conditions are accounted for by introducing a first order lag for engine deceleration and a second order lag for engine acceleration. Net thrust (forward or reverse) is computed as a function of Mach number and the actual engine pressure ratio. The second order function requires user inputs for engine spinup, natural frequency $f(EPR)$ table and damping ratio constant. The first order lag requires only the engine time constant.

The bleed and fan air pressures and temperatures are calculated as functions of corrected engine speed which is a two dimensional table lookup with Mach number and calculated thrust as independent variables. This calculation is common to both components.

A flowchart for the model ES is shown as Table 25 and Table 151 gives the detailed listing. A flowchart for the model EC is shown as Table 17 and Table 143 gives a detailed listing.

4.4.3 Yaw Control Thruster YC

The purpose of component YC is to simulate the effect of an auxiliary yaw thruster used to augment lateral dynamic stability of an ACLS equipped aircraft. The vectored thrust is a function of aircraft yaw angle or an input control signal. The vectored thrust may or may not be dependent on engine thrust i.e. the thruster could be powered independently.

A flowchart for the component YC is shown as Table 127 and Table 253 gives a detailed listing.

4.4.4 Pitch Control Thruster PT

The pitch control thruster provides longitudinal dynamic stability to an ACLS equipped vehicle. The component is identical in design to YC (4.4.3). A flowchart for the component PT is shown as Table 74 and Table 200 gives a detailed listing.

4.4.5 Roll Control Thruster RT

The roll control thruster is also identical in design to the other two thrusters, YC and PT, and provides roll stability. A flowchart for the component is shown as Table 81 and Table 207 gives a detailed listing.

4.5 Wind Components

4.5.1 Gust Wind Model GW

A wind gust model component developed under Contract F33615-76-C-3165 has been adapted for the ACLS library. The model simulates random wind gust components based on Dryden Spectra, in accordance with Section 3.7, MIL-F-8785B. The equations used in the computer code are directly taken from the MIL-F-8785B. Table 45 shows a flow chart, and Table 171 gives a detailed listing.

4.5.2 Steady or Shear Wind Model WS

The purpose of this component is to simulate wind shear or steady wind components. The wind magnitude quoted at control tower altitude of 50 feet is modified by a non-linear shear factor to reflect the change in wind with altitude. The wind vector is assumed parallel to the ground plane. The wind magnitude modified by shear is resolved along the runway coordinates North and East (fwd and side) and transformed into body axis. The derivation of equations is described in Section 2.5.2 Volume I. Table 123 shows a flowchart and Table 249 gives a detailed listing.

4.5.3 Summation of Wind Vectors SV

The total wind components are obtained by the summation of gust and steady/shear wind profiles in the body axis system and the summation is carried out in the component SV. Table 93 shows a flowchart and Table 219 gives a detailed listing.

4.6 Air Cushion System Components

4.6.1 Inelastic Trunk Model TK

This model represents the geometry and pneumatic characteristics of an inelastic trunk enclosing a cushion of air. The trunk is described by a finite number of elements which need not be uniform in cross section, width, or location on the vehicle.

The trunk is composed of three parts: side elements, fore elements and aft elements. The side elements have unconstrained outward movement subject to ground contact or changes in the cushion/trunk pressure ratio and are represented with a membrane model. The fore and aft elements experience little or no outward motion due to constraining peripheral stresses and are represented by a frozen model or a constrained membrane model (user option).

The inputs required are related to the trunk geometry such as section properties, attach points, coordinates, perforation arrangements etc., which can be obtained from detailed trunk drawings. The other data inputs needed are trunk damping coefficient as a function of trunk flattened area, relief valve opening as a function of trunk pressure and various flow discharge coefficients. For details see Reference 2, Volume I. A flowchart for the component is shown as Table 111 and Table 237 gives a detailed listing.

4.6.2 Elastic Trunk Model TS

The model represents the geometry and pneumatic characteristics of an elastic trunk enclosing a cushion of air. The trunk is described by a finite number of elements which need not be uniform in cross section, width or location on the vehicle.

The trunk model is comprised of two basic units: side elements and end elements. The end elements take into consideration membrane loads and deformations in both the hoop and meridian directions. For the side elements, the membrane loads and strains are computed for the meridian direction only; deformations in the hoop direction are assumed to be zero. As a user option, each element may be designated as a pillow brake element.

Inputs required include load/deflection characteristics for the membrane as well as inputs related to the trunk geometry such as section properties, membrane attach points, coordinates, perforation arrangements, etc. Other required data are trunk damping coefficient as a function of trunk flattened area, relief valve opening as a function of trunk pressure, pillow brake actuation signal, and various flow discharge coefficients. A flowchart for the component is shown as Table 115 and Table 241 gives a detailed listing.

4.6.3 Foster Miller Inelastic Trunk Model FM and 00

This model was developed by Foster Miller Associates Inc. and adapted by the Boeing Company for inclusion into the EASY program. The model includes the ACLS vehicle body dynamics using two orthogonal coordinate frames of reference; an inertial frame fixed in space and a vehicle frame fixed to the vehicle. The model also represents the geometry and pneumatic characteristics of an inelastic trunk enclosing a cushion of air.

The trunk model is made up of side segments and end segments. Side segments are represented by a simple two-dimensional membrane, and end segments are represented by a frozen model.

Inputs required must describe not only the trunk geometry as with component TK, but also the fan performance (static and dynamic) as polynomial functions, the side membrane height as a polynomial function of pressure ratio, relief valve dimensions, trunk perforation details, etc.

The component FM may be used in the Foster Miller mode (user option) to duplicate all static and dynamic analytical capabilities of the FMA/NASA ACLS program. The component may also be used in the EASY mode (user option) to perform the standard EASY analyses i.e. steady state, linear analysis and simulation.

The component OO was developed to display variables of interest during program execution, and must be used in conjunction with component FM.

Flowcharts for components FM and OO are included as Tables 33 and 66 respectively. Subroutine listings are provided as Tables 159 and 192.

4.6.4 Air Bag Model AB

The model represents the geometry and pneumatic characteristics of two parallel inelastic airbags. The bags are described by a finite number of elements which need not be uniform in cross section, width, or location on the vehicle. The air bag elements have unconstrained lateral movement subject to ground friction forces in the Y-axis and are represented by a membrane model. The basic design concepts for the air bag model are identical to those for the trunk model. For derivation of model equations and other details, see Reference 2, Volume I, Section VII.

A flowchart for the model is shown as Table 2 and Table 128 gives a detailed listing.

4.6.5 Arresting Gear Model AS

The model simulates the dynamic response of a Water Twister type of arresting system composed of a steel cable pendant, nylon tape and a water twister energy absorber.

The Water Twister (Registered Trademark) is a simple water brake that converts kinetic energy to heat through turbulence. The brake consists of a fluid filled steel casing, with internal stator vanes, which houses a vaned centrifugal rotor. The rotor is mounted on a shaft which extends out of the top of the casing. A storage reel for a nylon tape purchase element is mounted on and splined to the top end of the rotor shaft. The tape is wrapped on this storage reel, layer on layer, forming a spiral wrap. Pulling the tape off the reel causes the shaft and vaned rotor to revolve within the fluid filled casing, creating turbulence. For derivation of model equations and other details, see Reference 2, Volume I, Section VIII. A flowchart for the model is shown as Table 8 and Table 134 gives a detailed listing.

4.7 Optimal Controller OC

This section pertains to a unique component in the EASY library, the optimal controller OC. User inputs for utilization of this component are described in Reference 2.

A complete description of the calculation methods and theoretical basis for the optimal controller are presented in Reference 2, Section 4.5. Further elaboration is presented in Reference 2, Volume IV. A flowchart for the subroutine is shown as Table 64 and a listing of OC is presented in Table 190.

4.8 Atmospheric Flight Conditions FL

The purpose of model FL is to calculate the ambient data given the airplane's altitude and Mach number. Outputs from the subroutine are the ambient pressure, ambient temperature, ram pressure and ram temperature. The ambient and ram temperatures are calculated by defining the type of day, i.e.:

- Day = 1 MIL-STD-210B Operation (1 percent risk) Hot Day
- 2 MIL-STD-210A Hot Day
- 3 MIL-STD-210A Tropical Day
- 4 U.S. Standard Atmosphere (Default)
- 5 MIL-STD-210A Polar Day
- 6 MIL-STD-201A Cold Day
- 7 MIL-STD-210B Operational (1 percent risk) Cold Day

The ram pressure is calculated assuming 100% recovery.

A flowchart for this subroutine is shown in Table 31 and Table 157 gives a detailed listing.

SECTION V

FLOW CHARTS

This section contains all the EASY ACLS subroutine flow charts in alphabetical order by subroutine name.

Table 2: FLOWCHART FOR SUBROUTINE AB

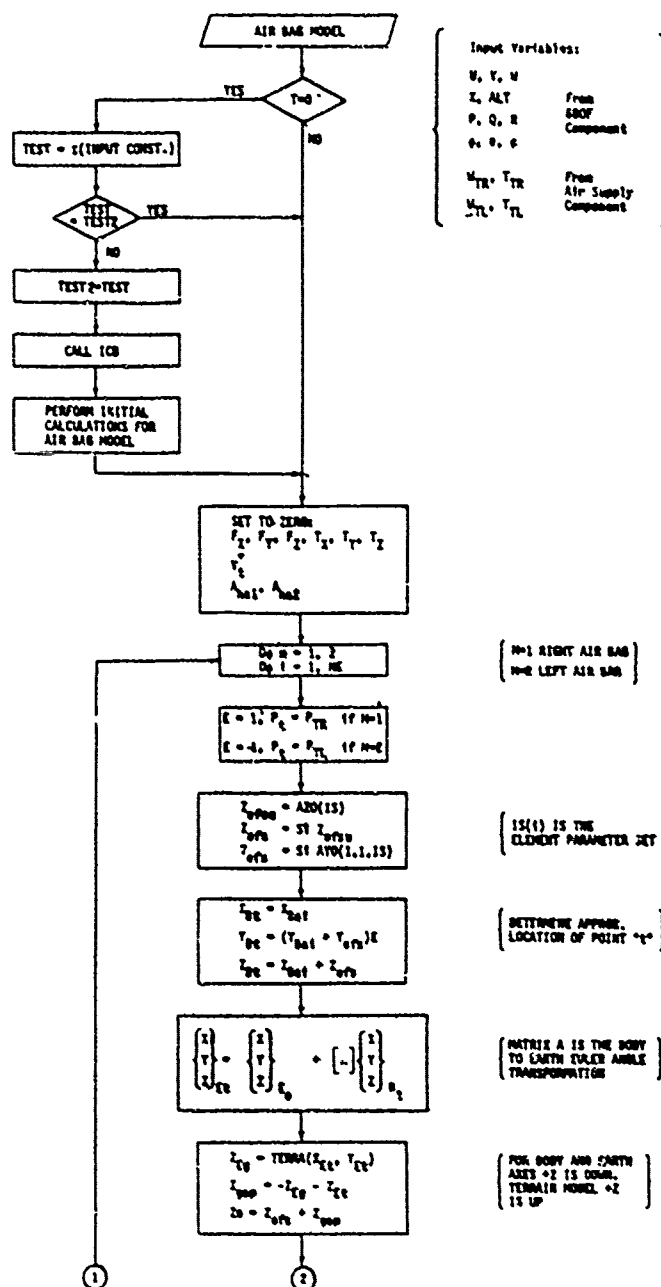

Table 2: FLOWCHART FOR SUBROUTINE AB (CONCLUDED)

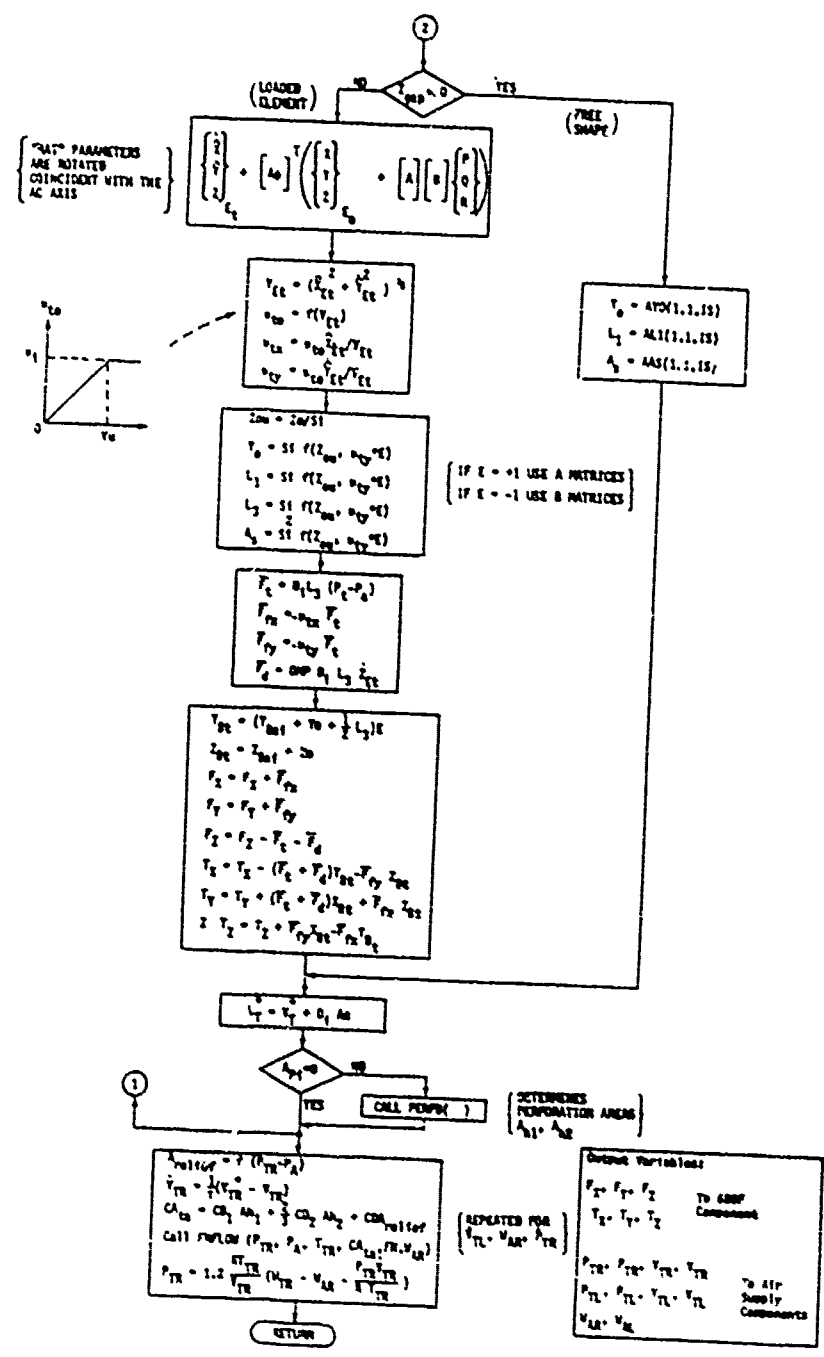

Table 3: FLOWCHART FOR SUBROUTINE AC

SUBROUTINE AC (CLT, CDT, CMT, CYT, CLBT, CNBT, CL, CD, CM, CY, CLB, CNB, AL, BE)

VERSION 1. JUN 1977

PURPOSE STANDARD JINDIVIK AERODYNAMIC DATA - REF. AERO TECH MEMO 222. USED FOR TASK 2 TRIM AND DYNAMIC FLIGHT CONDITIONS.

METHOD AERODYNAMIC COEF ARE INTERPOLATED FROM TABLES.

CALL SEQUENCE

TABLES

CLT -COEF OF LIFT VS. ANGLE OF ATTACK
 CDT -COEF OF DRAG VS. COEF OF LIFT
 CMT -COEF OF PITCH MOMENT VS. COEF OF LIFT
 CYT -COEF OF SIDE FORCE VS. ANGLE OF SIDE SLIP
 CLBT -DERIVATIVE, ROLLING MOMENT DUE TO SIDE SLIP VS ANGLE OF ATTACK
 CNBT -DERIVATIVE, YAWING MOMENT DUE TO SIDE SLIP VS ANGLE OF ATTACK

OUTPUTS

CL -COEF OF LIFT
 CD -COEF OF DRAG FORCE
 CM -COEF OF PITCH MOMENT
 CY -COEF OF SIDE FORCE
 CLB -ROLL MOMENT DERIVATIVE
 CNB -YAW MOMENT DERIVATIVE

INPUTS

AL -ANGLE OF ATTACK
 BE -SIDE SLIP ANGLE

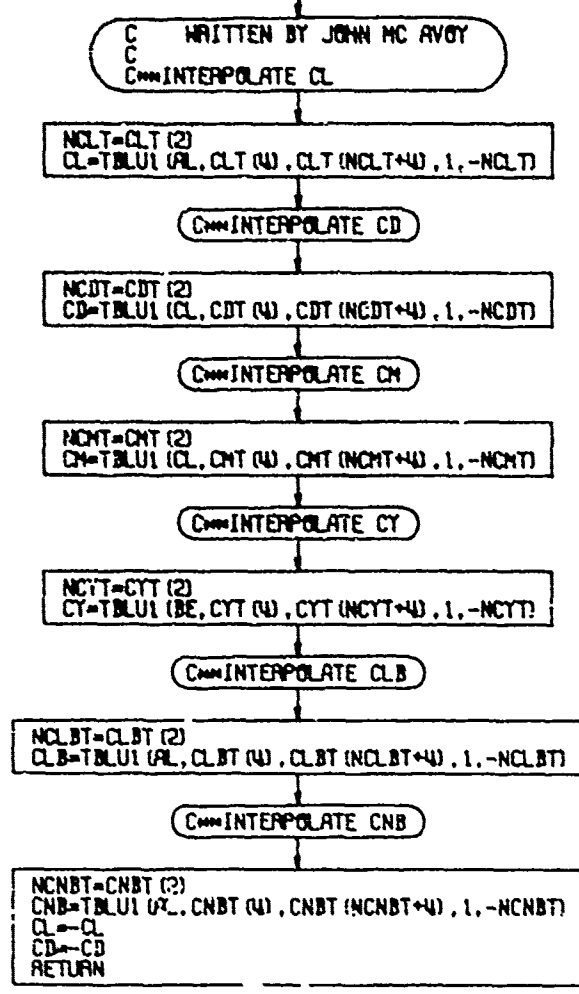

Table 4: FLOWCHART FOR SUBROUTINE AF

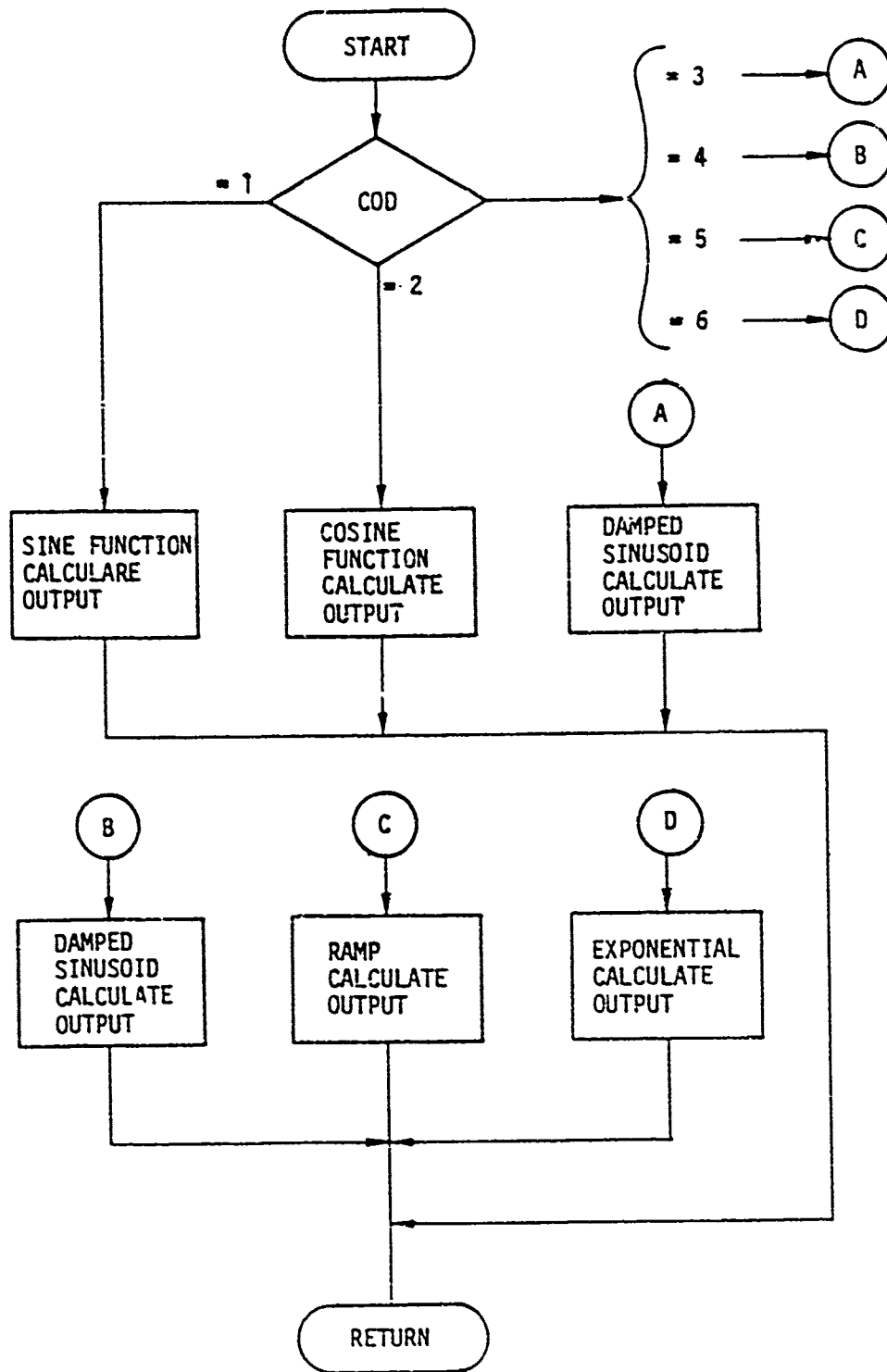

Table 5: FLOWCHART FOR SUBROUTINE AMACH

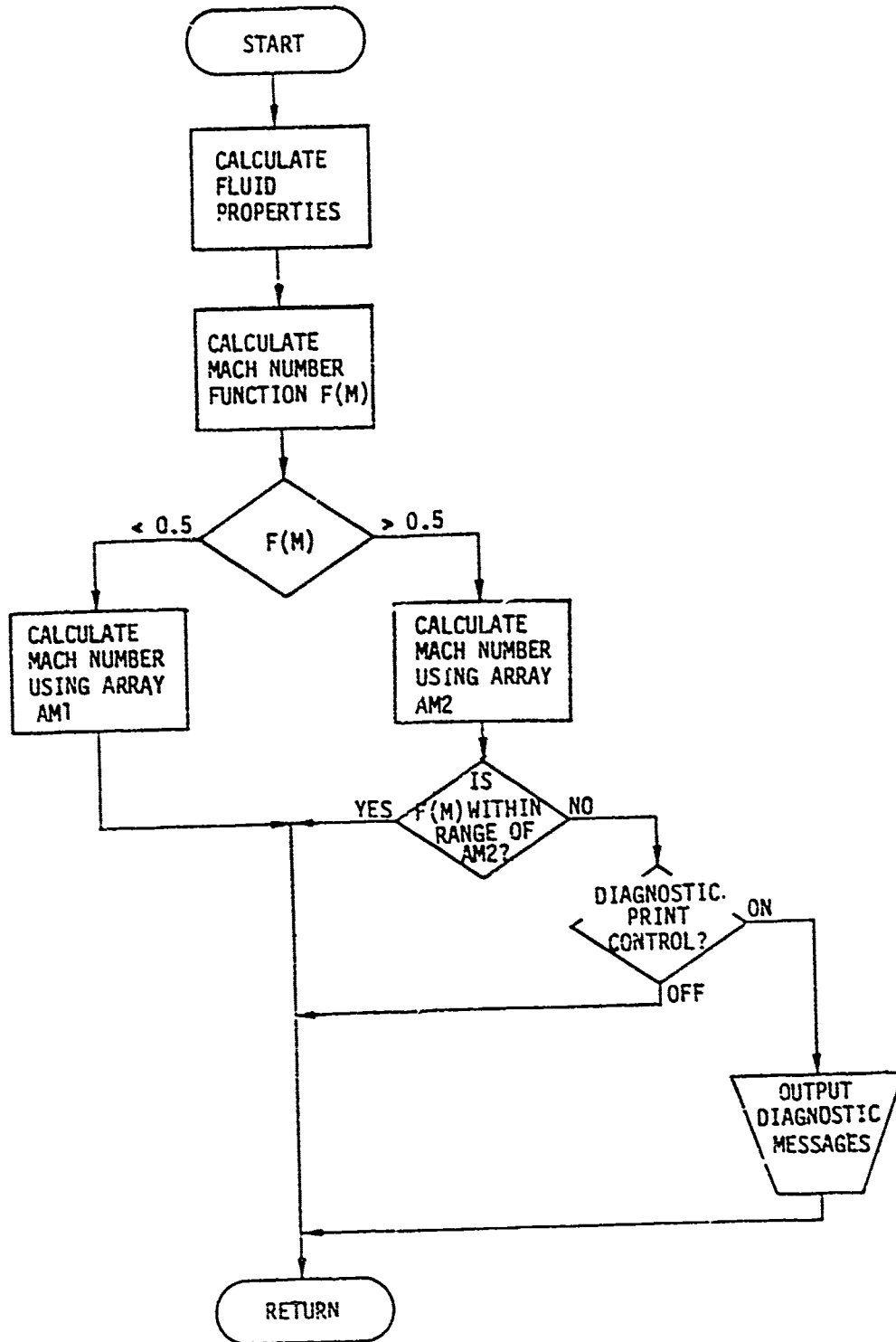
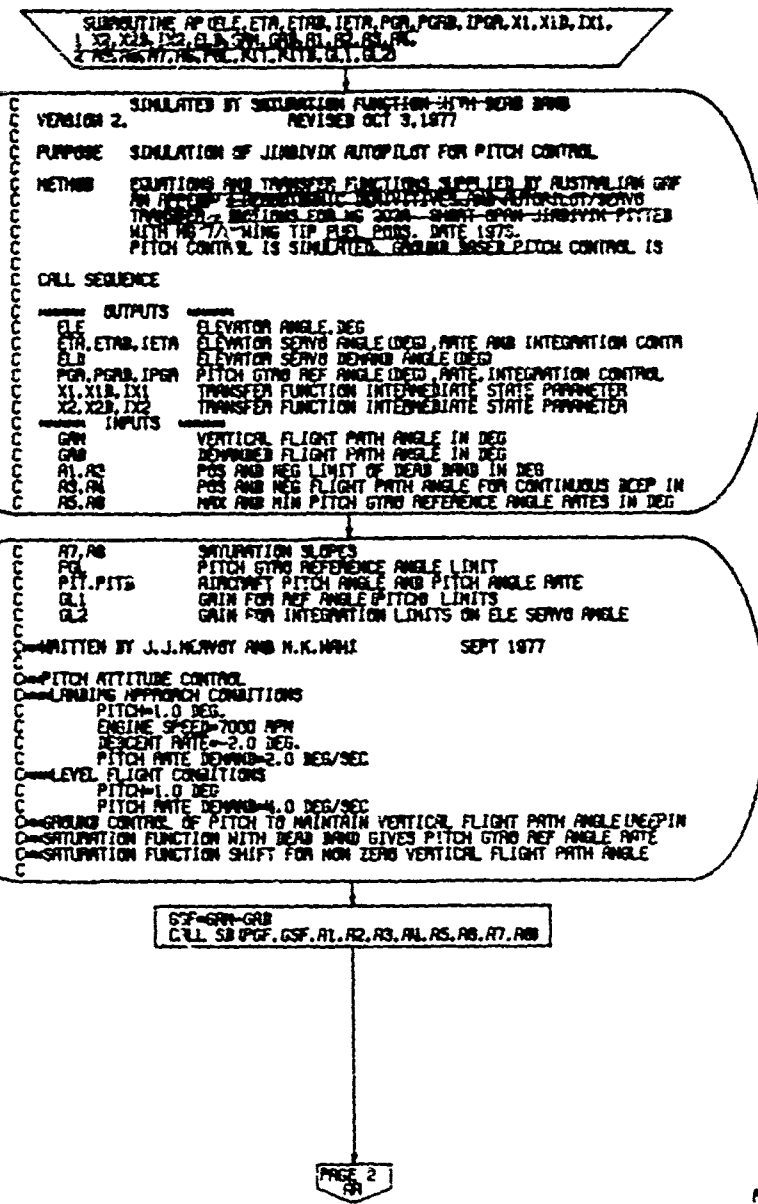

Table 6: FLOWCHART FOR SUBROUTINE AP



76

Table 6: FLOWCHART FOR SUBROUTINE AP (CONCLUDED)

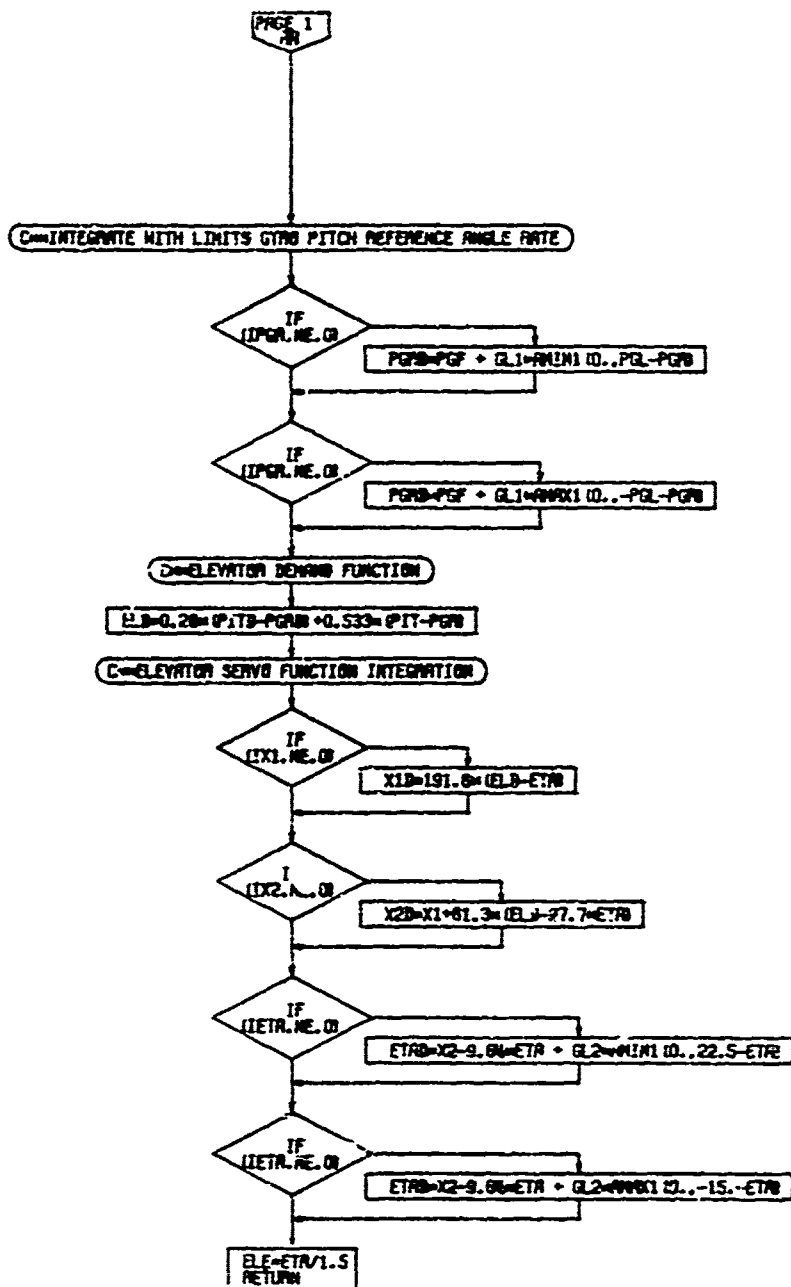

Table 7: FLOWCHART FOR SUBROUTINE AR

SUBROUTINE AR (AIL, ZET, ZETD, IZET, RGR, RGRD, IAGR, R1, R1D, IR1,
R2, R2D, IR2, X1, X1D, IX1, X2, X2D, IX2, AID, AZI, CRS, DC, ROL, ROLD, R,
2 GL1, GL2)

VERSION 2. REVISED OCT 3, 1977

PURPOSE SIMULATION OF JINDIVIK AUTOPILOT FOR ROLL CONTROL

METHOD EQUATIONS AND TRANSFER FUNCTIONS SUPPLIED BY AUSTRALIAN GAF
AN APPENDIX-AERODYNAMIC DERIVATIVES AND AUTOPILOT/SERVO
TRANSFER FUNCTIONS FOR MK 203A SHORT SPAN JINDIVIK FITTED
WITH MK 1/8 WING TIP FUEL PODS DATE 1973

CALL SEQUENCE

OUTPUTS	PARAMETERS
AIL	AILERON DEFLECTION, DEG
ZET, ZETD, IZET	AILERON SERVO DEFLECTION (DEG), RATE, INTEGRATION CONTR
RGR, RGRD, IAGR	ROLL gyro REFERENCE ANGLE (DEG), RATE, INTEGRATION CONTR
AID	AILERON SERVO DEMAND ANGLE (DEG) FROM AUTOPILOT
R1, R1D, IR1	SERVO MOTOR PARAMETER, RATE, INT CONTROL
R2, R2D, IR2	SERVO MOTOR PARAMETER, RATE, INT CONTROL
X1, X1D, IX1	SERVO MOTOR INTERMEDIATE STATE, RATE, INT CONTROL
X2, X2D, IX2	SERVO MOTOR INTERMEDIATE STATE, RATE, INT CONTROL
INPUTS	PARAMETERS
AZI	AIRCRAFT AZIMUTH (+ CLOCKWISE, DEG)
CRS	DEMANDED AIRCRAFT COURSE (+ CLOCKWISE, DEG)
DC	ALLOWABLE COURSE ERROR (+/- DEG)
ROL	AIRCRAFT ROLL ANGLE (DEG)
ROLD	AIRCRAFT ROLL ANGLE RATE (DEG/SEC)
R	AIRCRAFT YAW RATE, DEG/SEC
GL1	GAIN FOR gyro REF ANGLE LIMITS

GL2 GAIN FOR INTEGRATION LIMITS ON AILERON SERVO ANGLE

WRITTEN BY J.J. McAVOY AND M.K. WAHI SEPT 1977

AIRCRAFT COURSE CONTROL BY GROUND COMMANDS.

GROUND CONTROL COMMAND LEFT OR RIGHT TURN WHICH CAUSES ROLL gyro REF ANGLE TO ROTATE AT 10 DEG/SEC, gyro REF ANGLE IS LIMITED TO + 30 DEG

STRAIGHT COMMAND CAUSES gyro REF ANGLE TO DEROTATE AT 10 DEG/SEC UNTIL REF ANGLE IS ZERO.

TRGRD=0.0

PAGE 2
AR

PAGE 1
AR

Table 7: FLOWCHART FOR SUBROUTINE AR (CONTINUED)

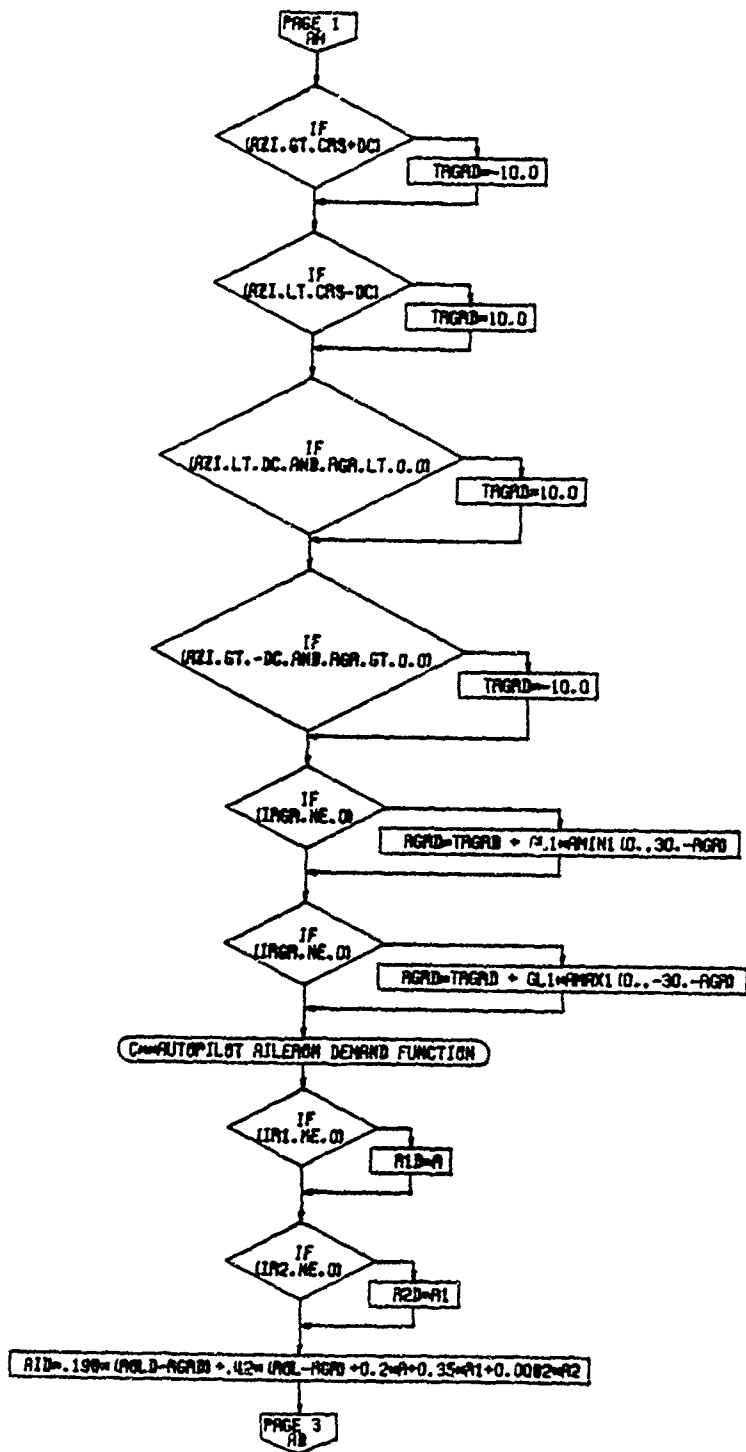

PAGE 2
AR

Table 7: FLOWCHART FOR SUBROUTINE AR (CONCLUDED)

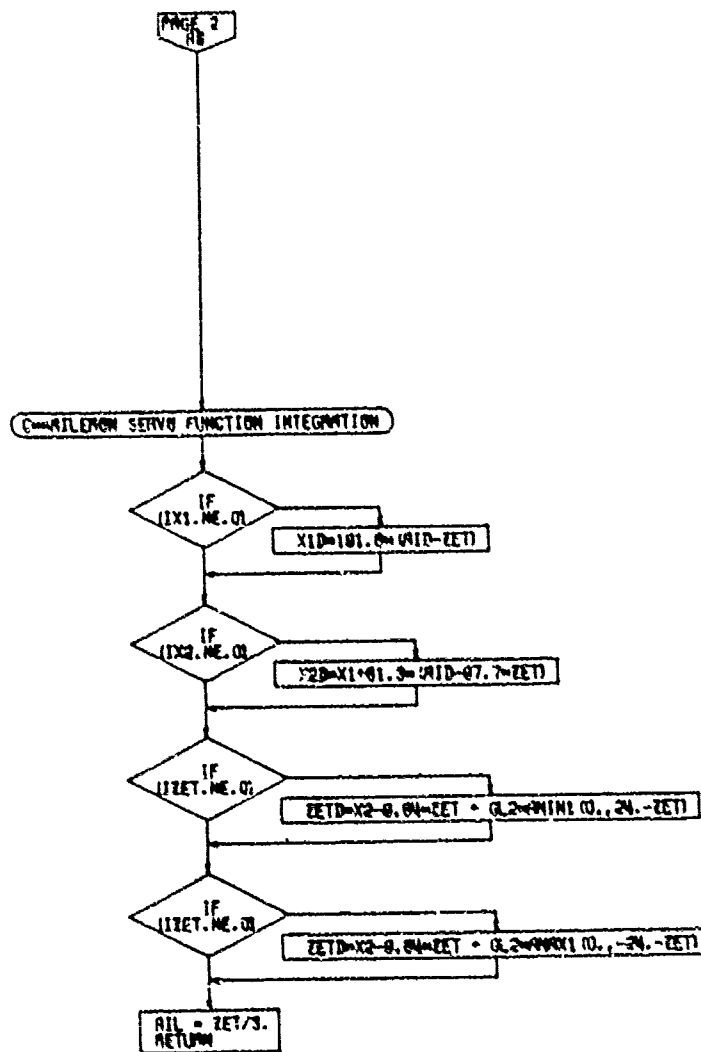

PAGE 3
AR

Table 8: FLOWCHART FOR SUBROUTINE AS

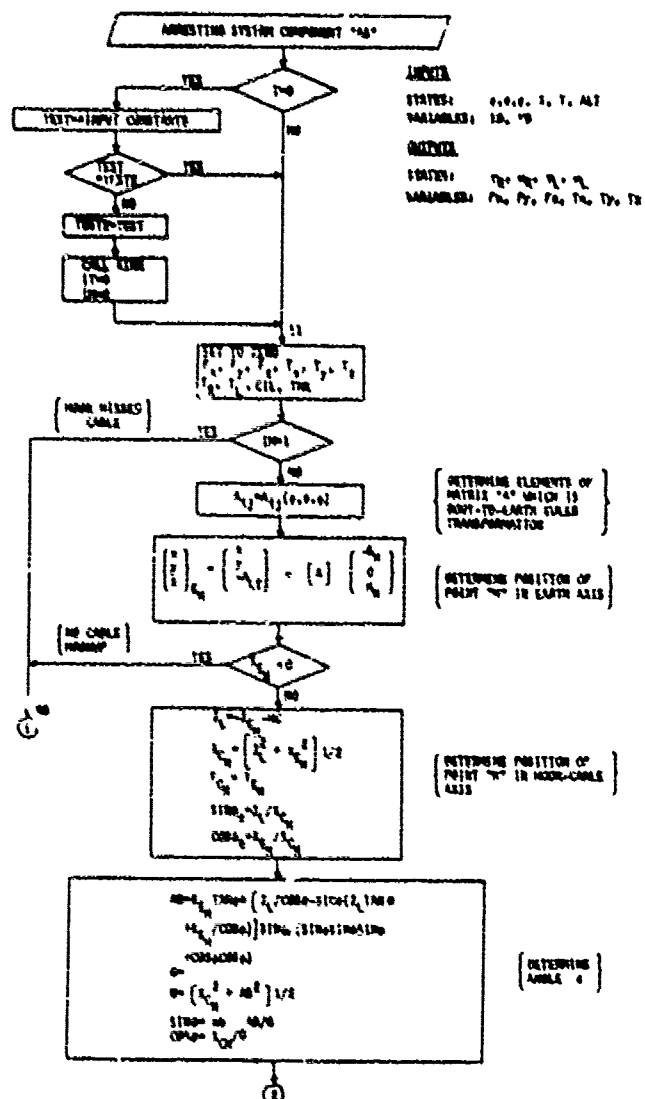

Table 8: FLOWCHART FOR SUBROUTINE AS (CONTINUED)

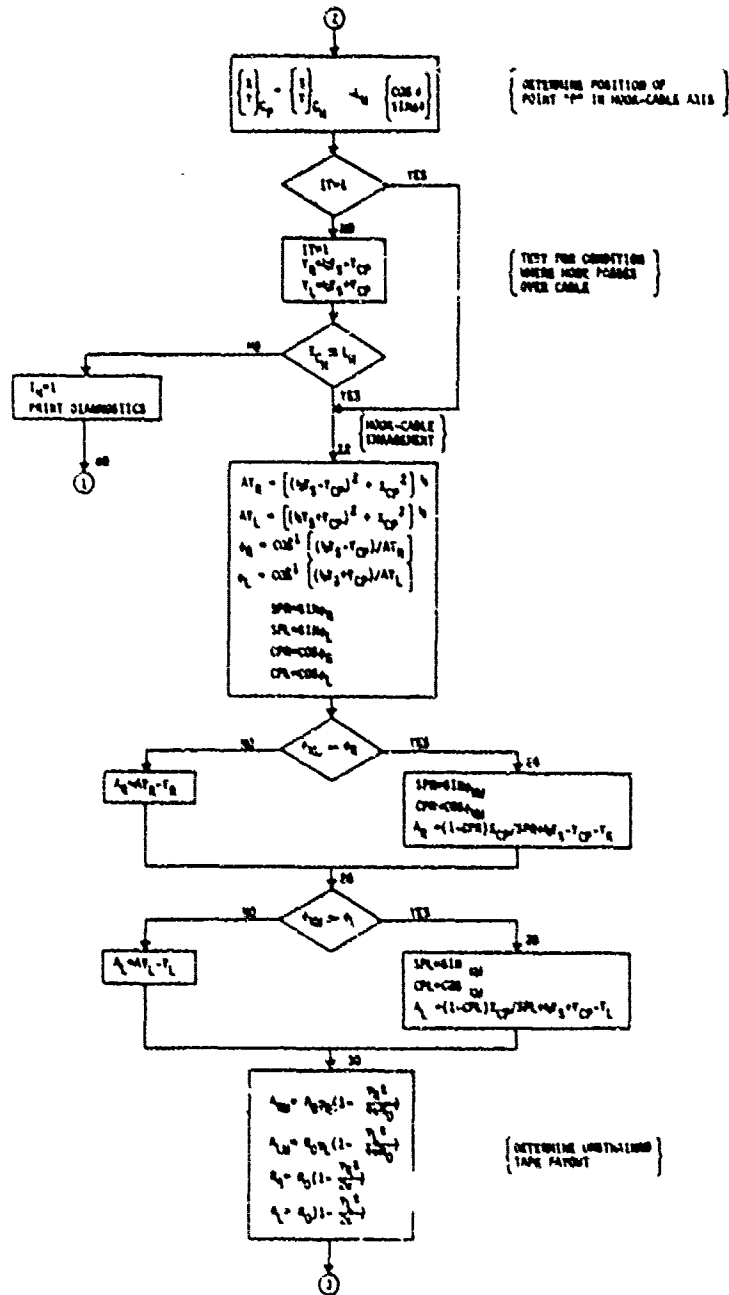

Table 8: FLOWCHART FOR SUBROUTINE AS (CONCLUDED)

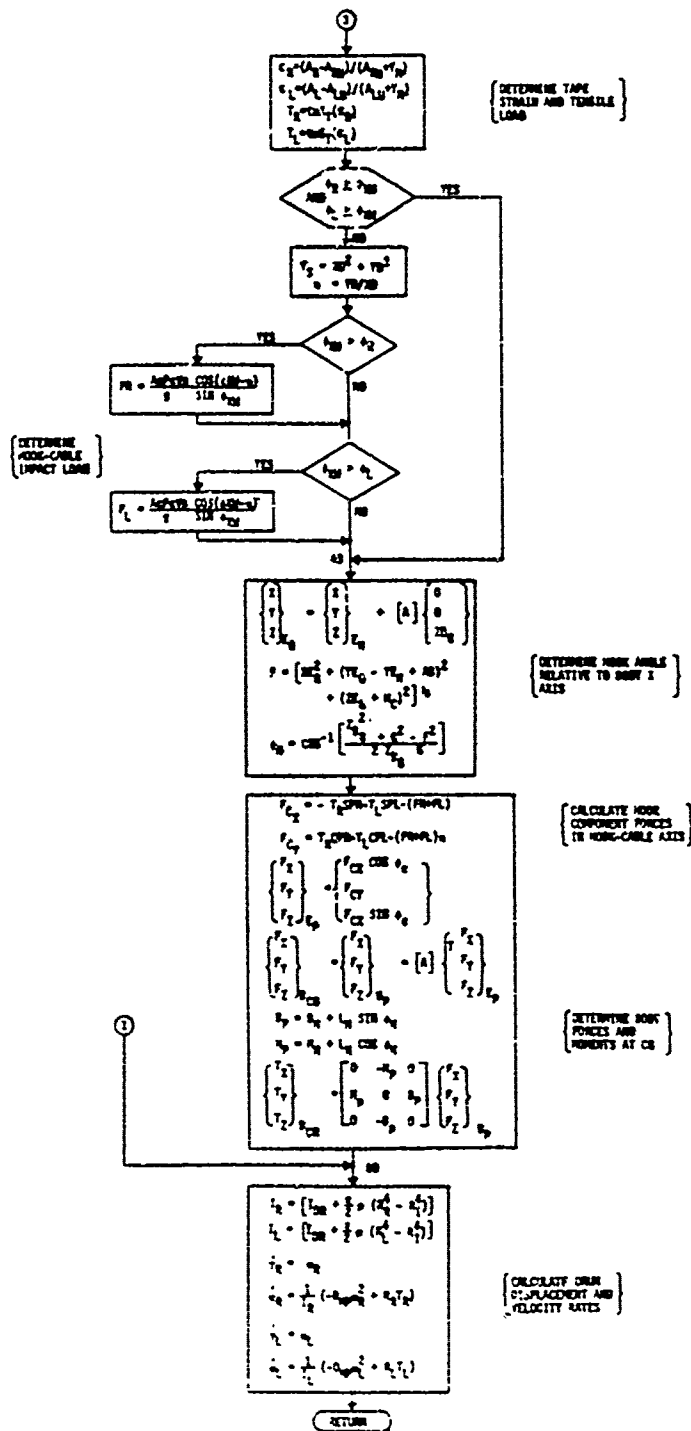
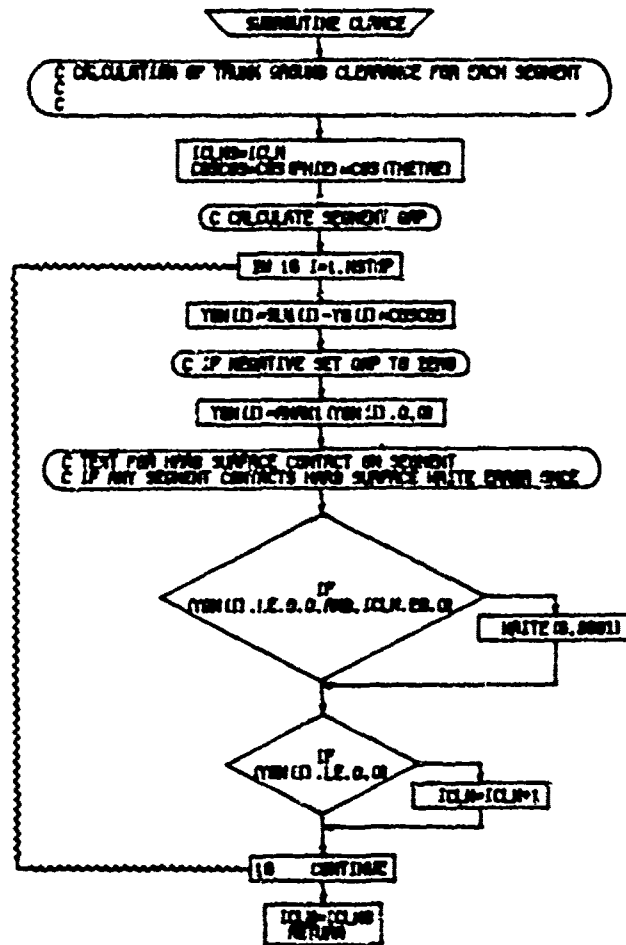

Table 9: FLOWCHART FOR SUBROUTINE CLRNC



PAGE 1
CLRNC

Table 10: FLOWCHART FOR SUBROUTINE CDVCHP

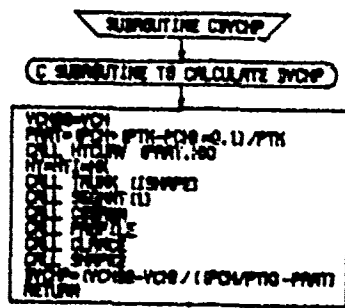

Table 17: FLOWCHART FOR SUBROUTINE COORDN

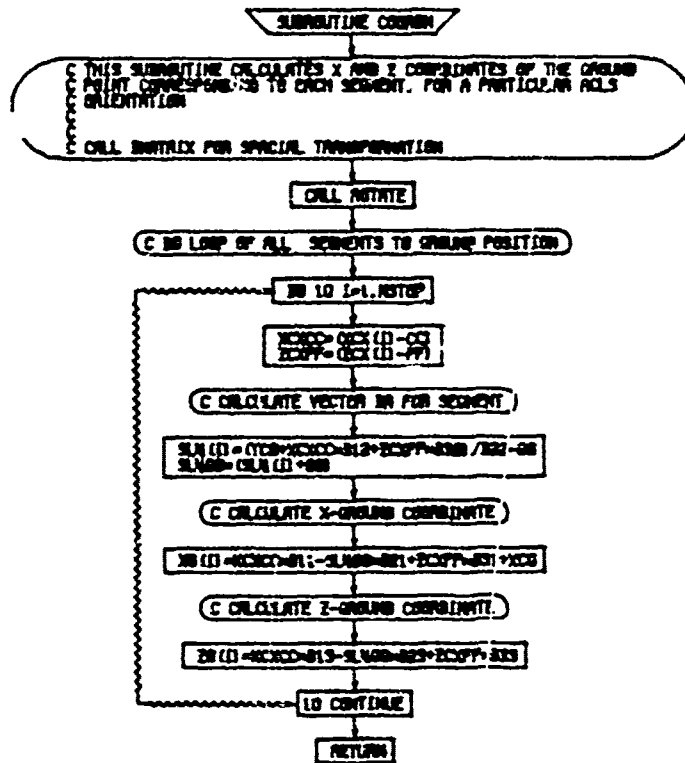

Table 12: FLOWCHART FOR SUBROUTINE DL

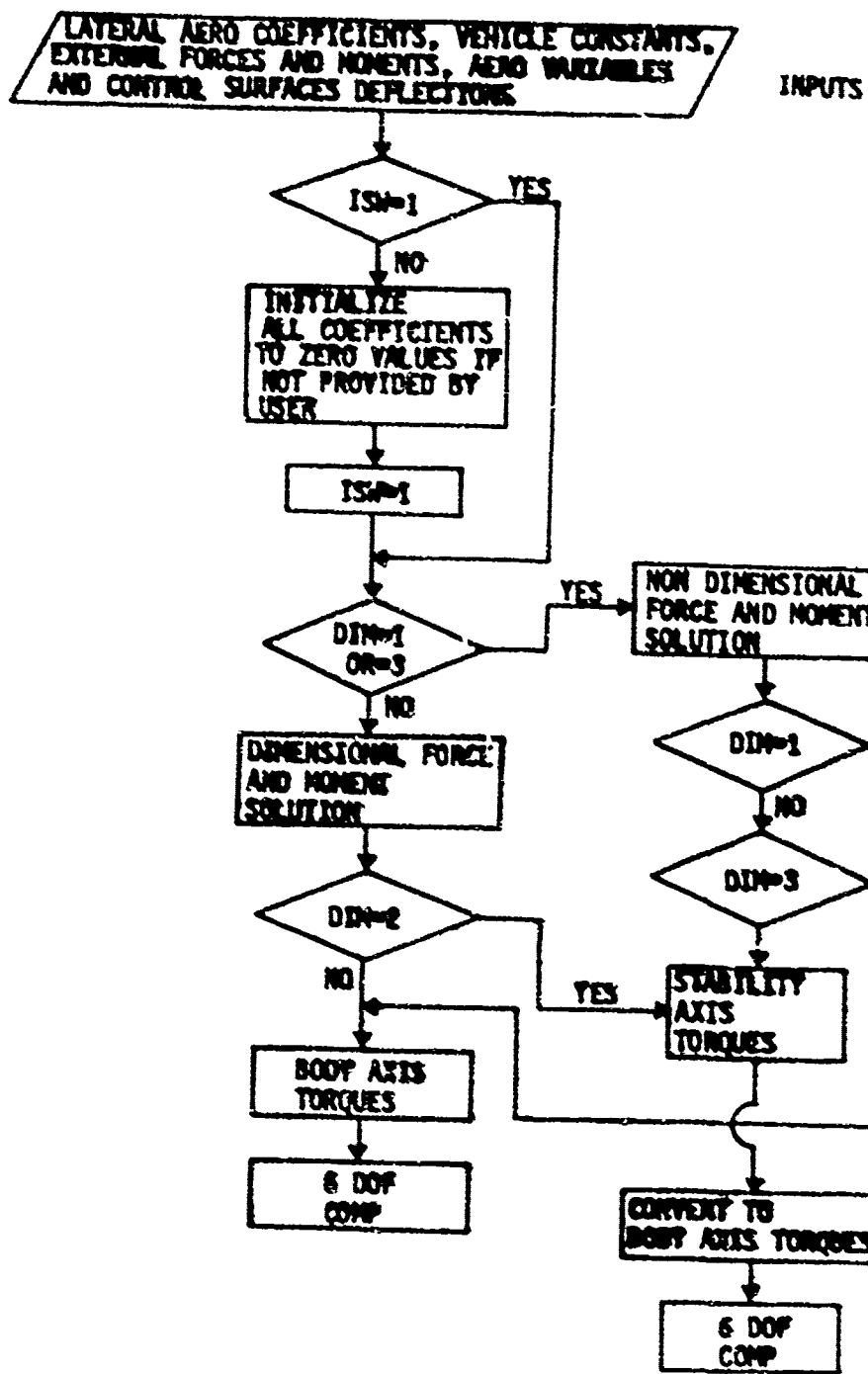

Table 13: FLOWCHART FOR SUBROUTINE DS

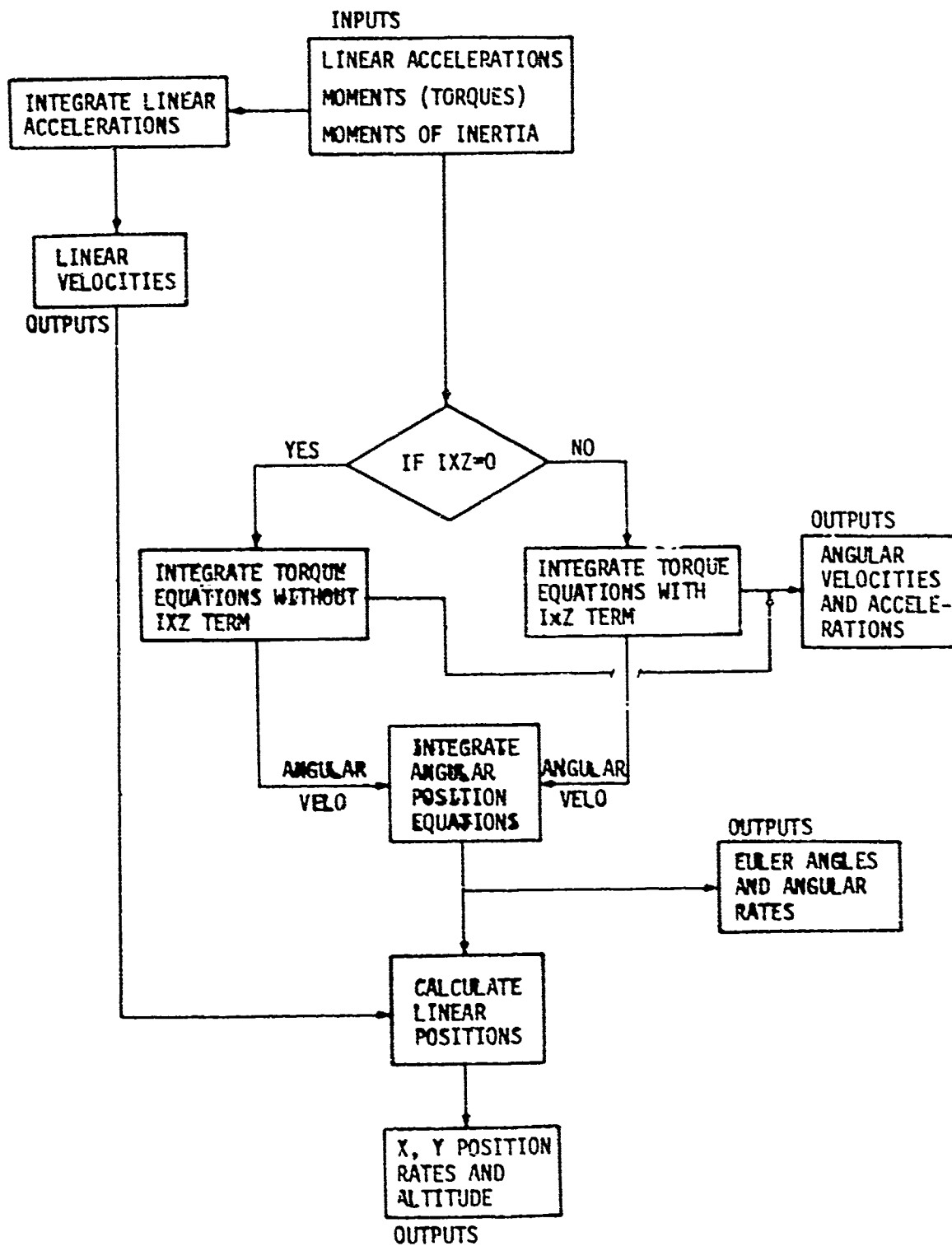

Table 14: FLOWCHART FOR SUBROUTINE DU

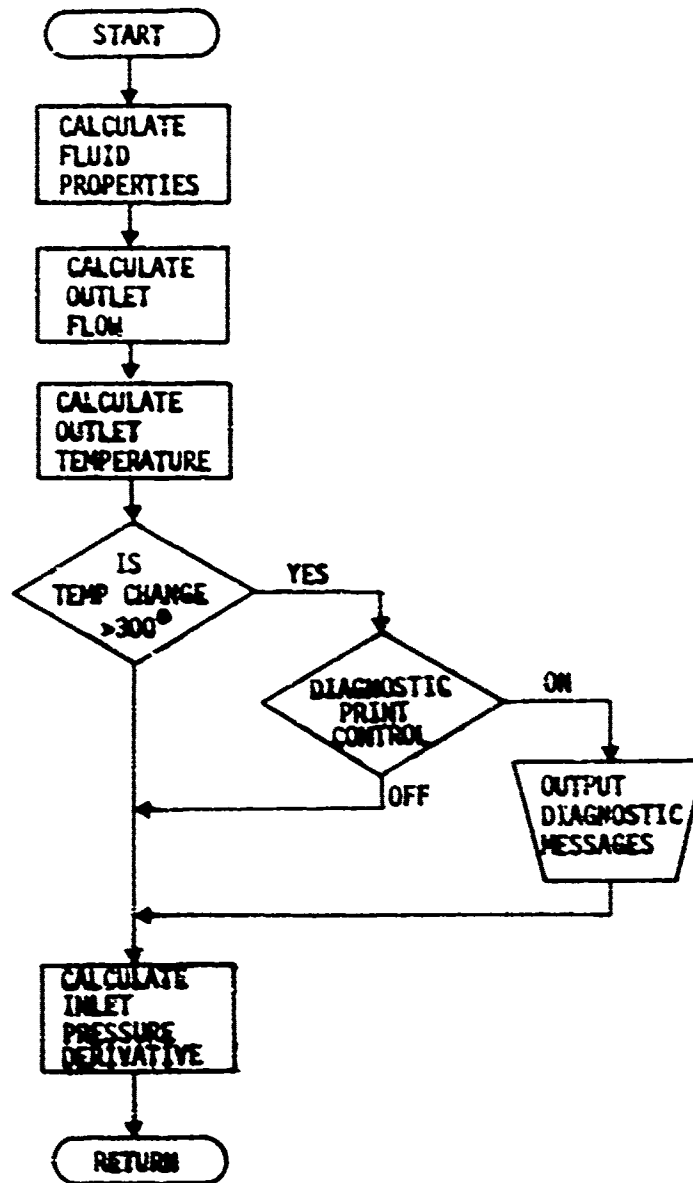

Table 15: FLOWCHART FOR SUBROUTINE DV

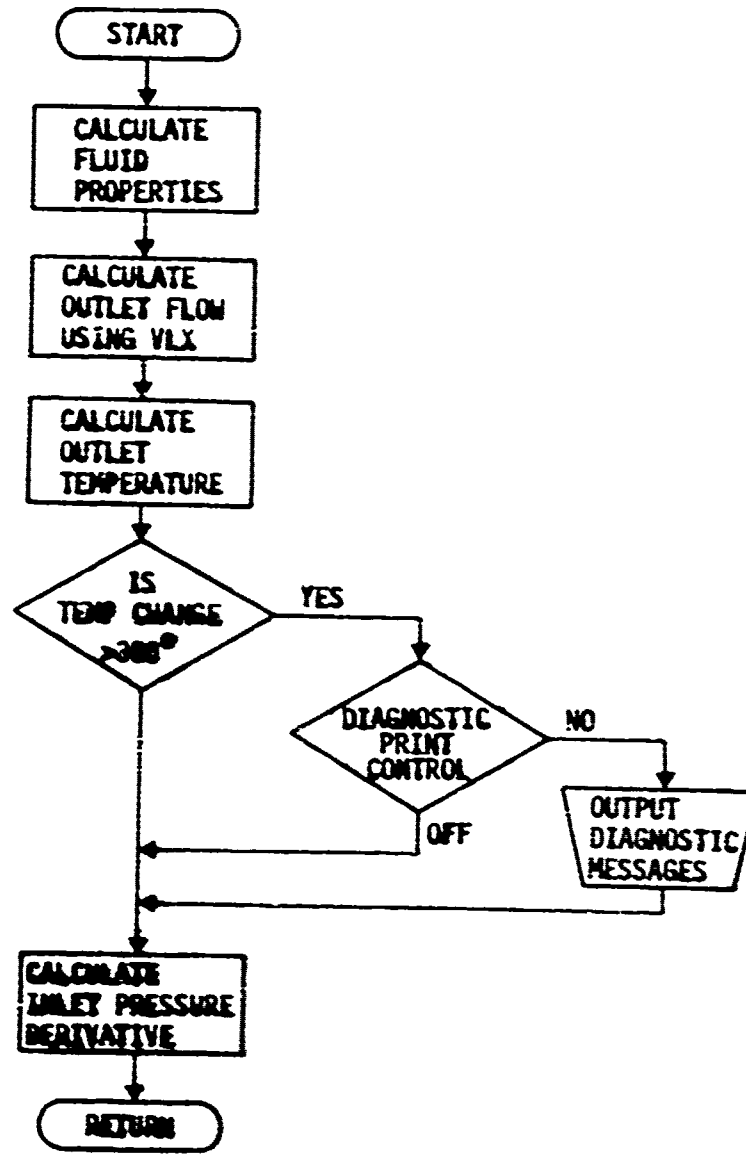

Table 16: FLOWCHART FOR SUBROUTINE DYNFAN

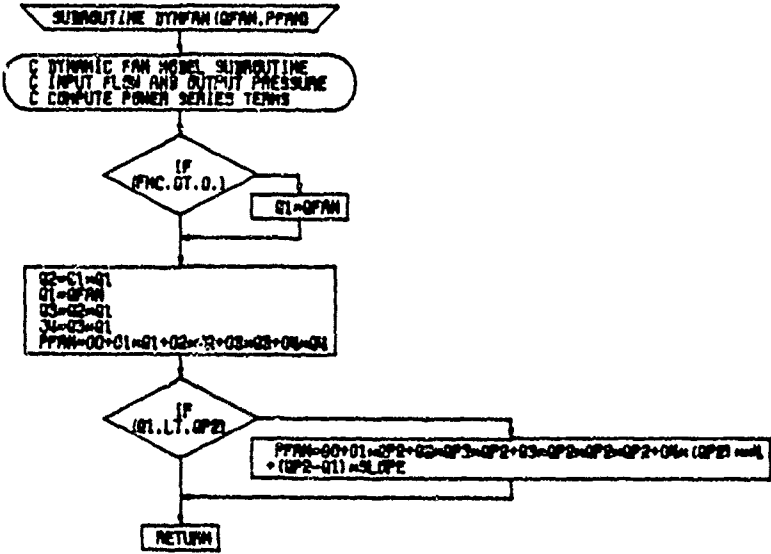

Table 17: FLOWCHART FOR SUBROUTINE EC

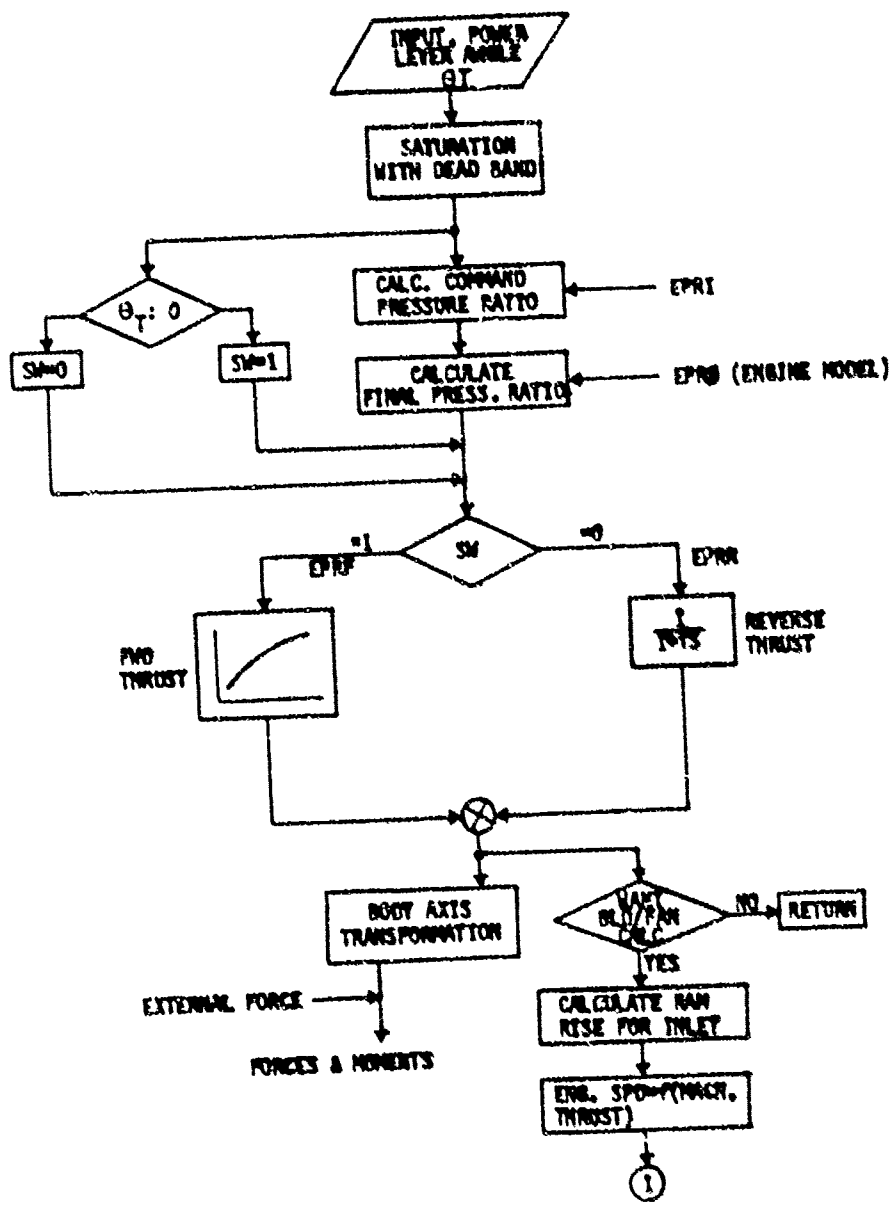

Table 17: FLOWCHART FOR SUBROUTINE EC (CONCLUDED)

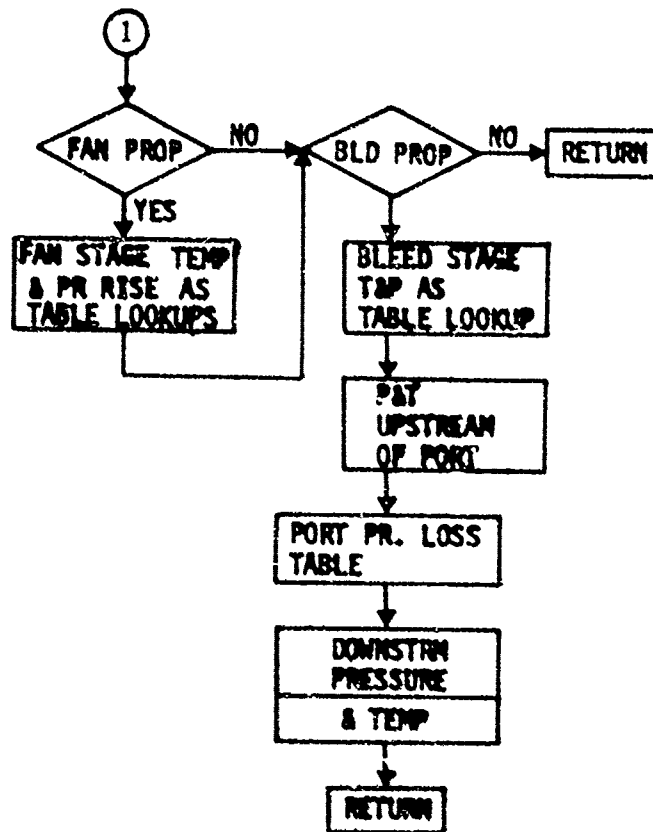

Table 18: FLOWCHART FOR SUBROUTINE EJ

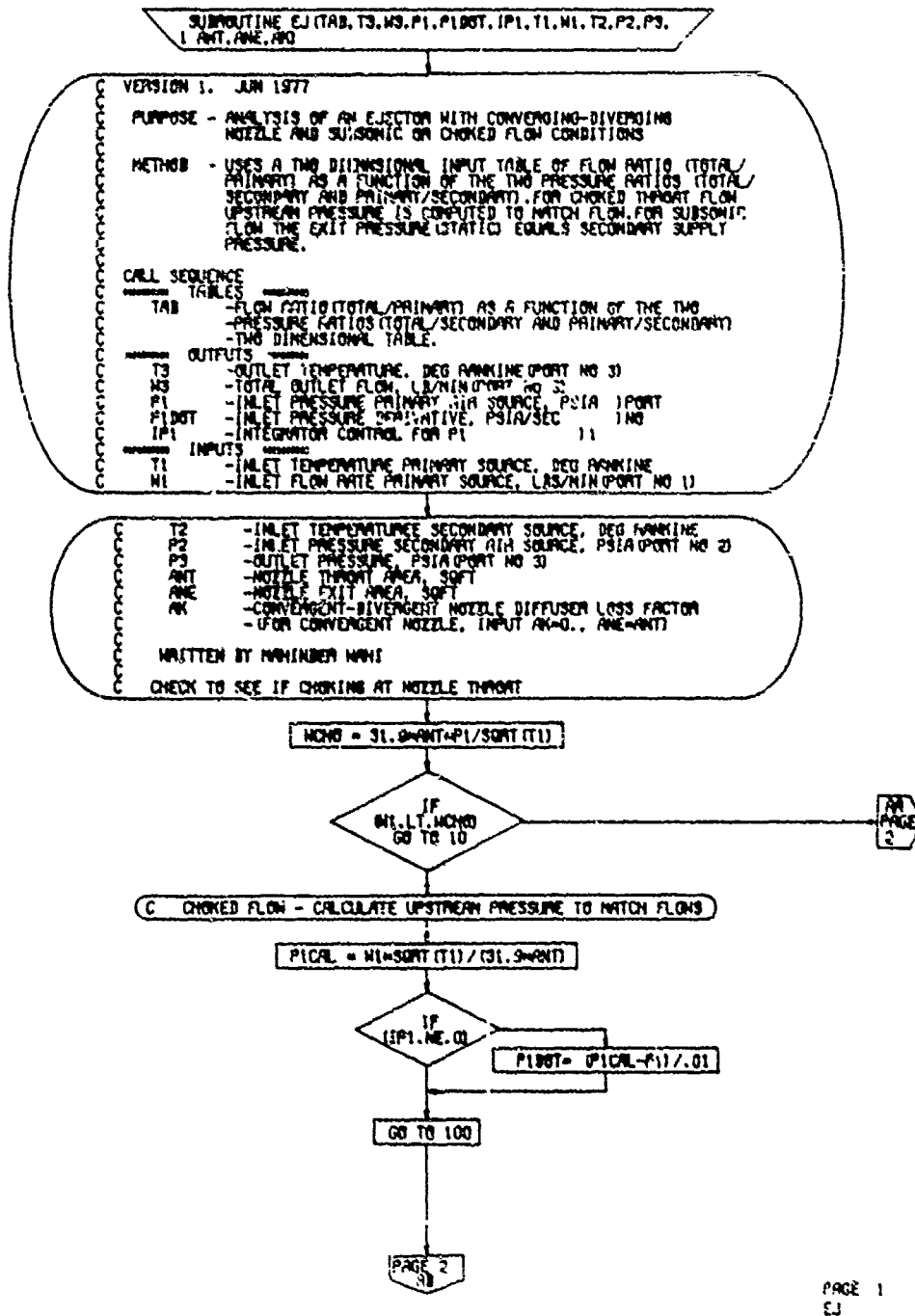
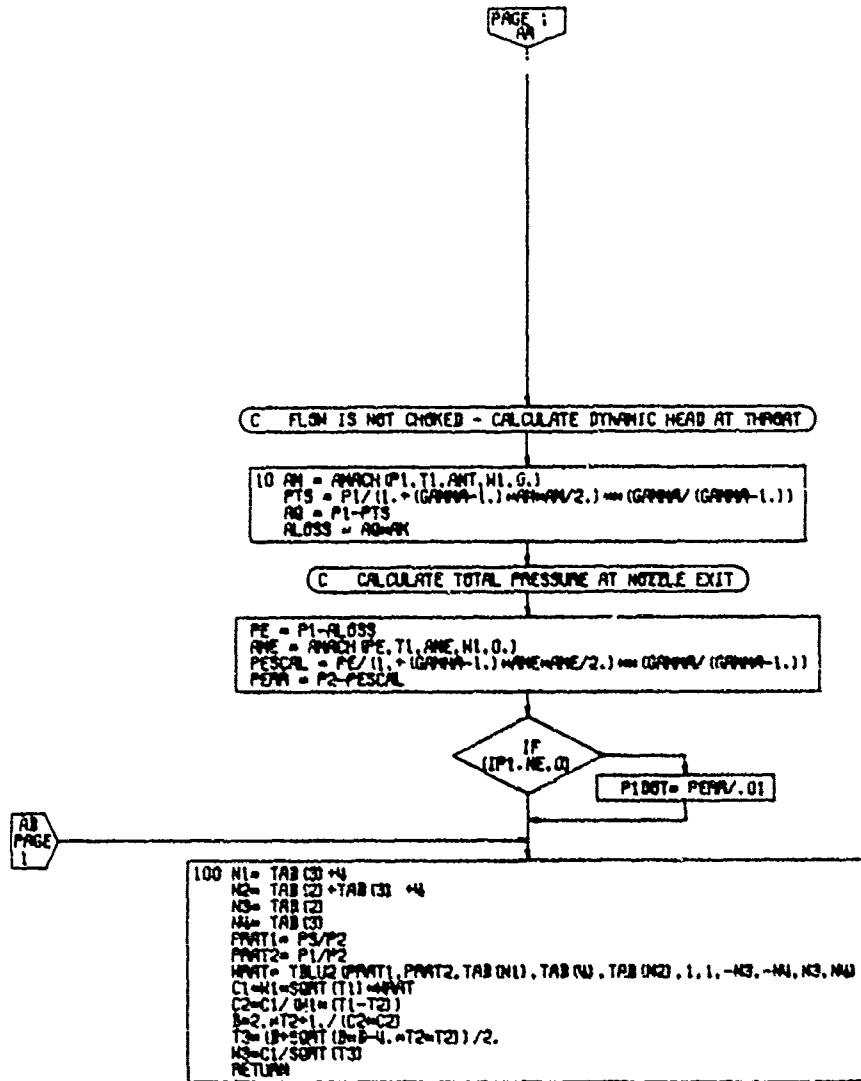
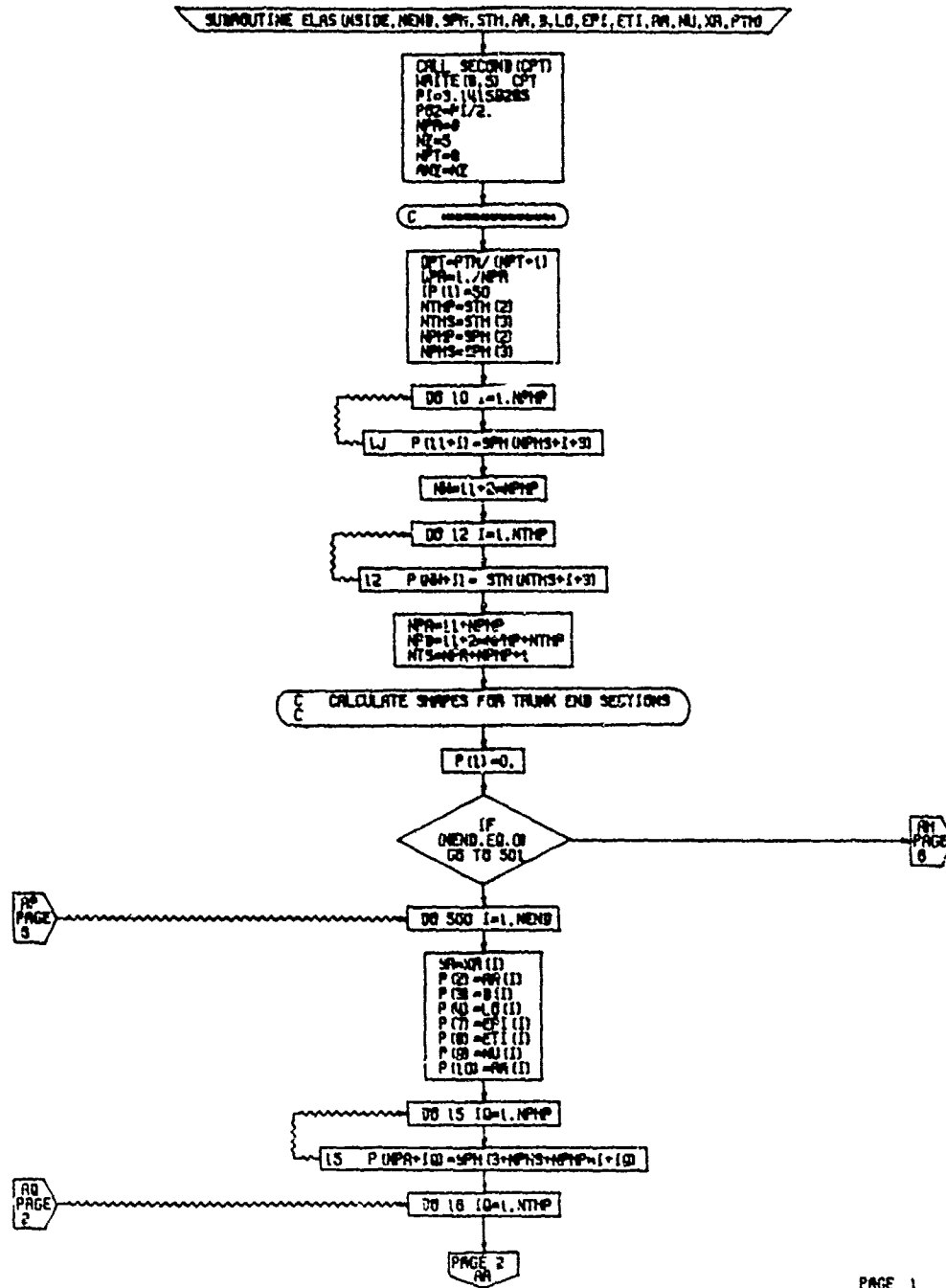

Table 18: FLOWCHART FOR SUBROUTINE EJ (CONCLUDED)



PAGE 2
EJ

Table 19: FLOWCHART FOR SUBROUTINE ELAS



PAGE 1
ELAS

Table 19: FLOWCHART FOR SUBROUTINE ELAS (CONTINUED)

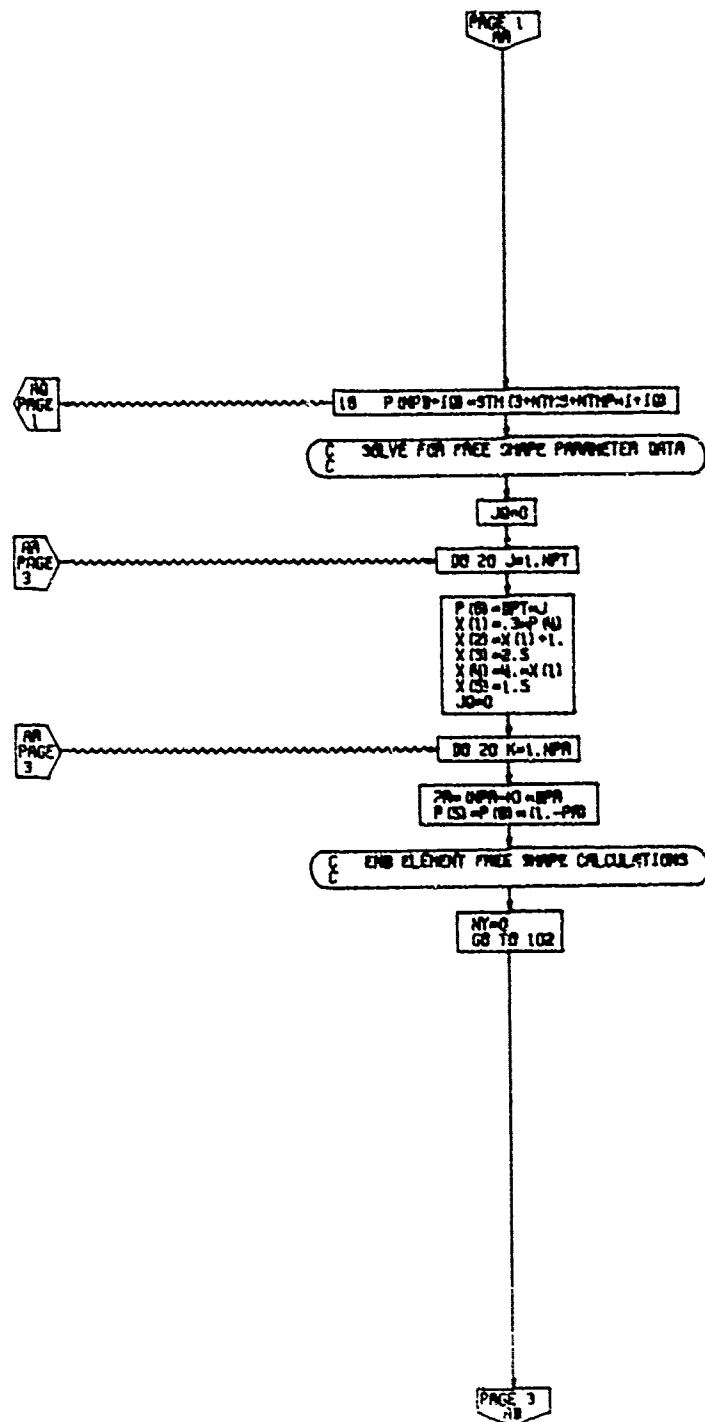

PAGE 2
ELAS

Table 19: FLOWCHART FOR SUBROUTINE ELAS (CONTINUED)

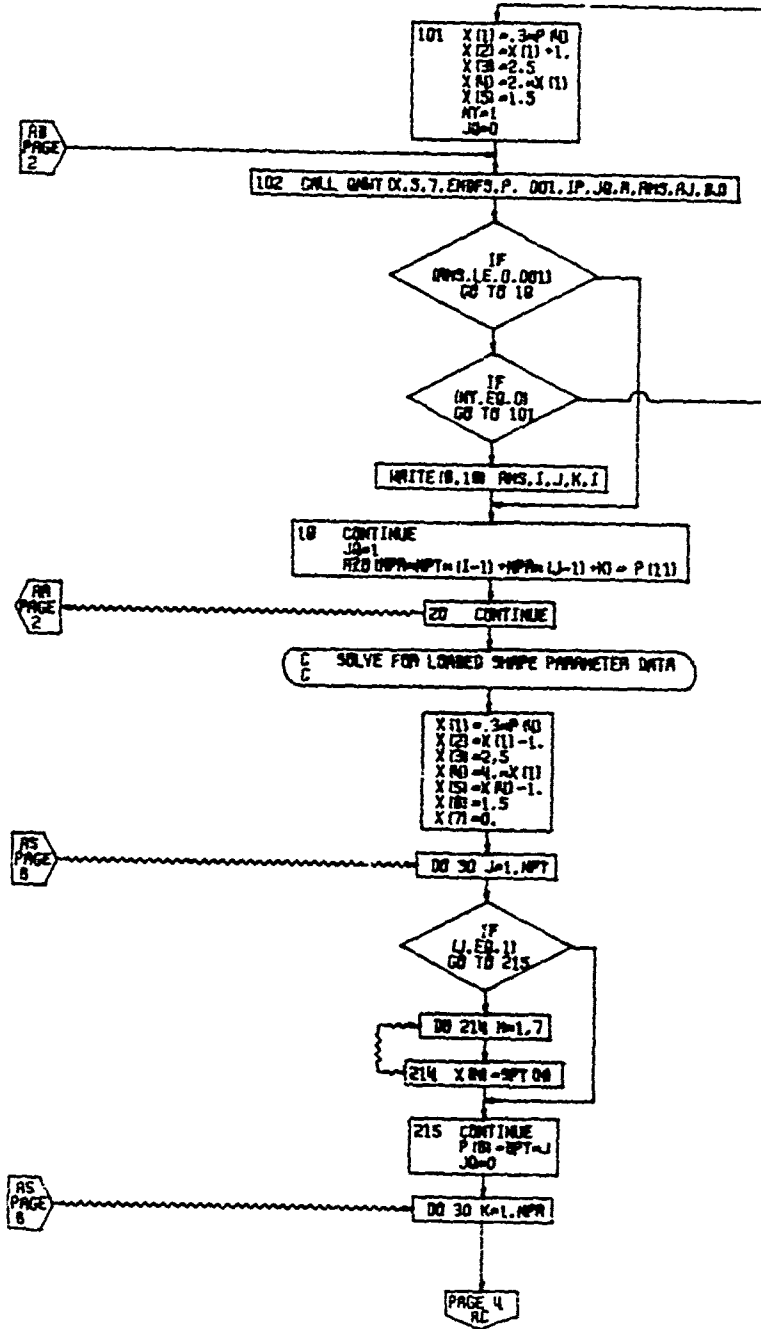

PAGE 3
ELAS

Table 19: FLOWCHART FOR SUBROUTINE ELAS (CONTINUED)

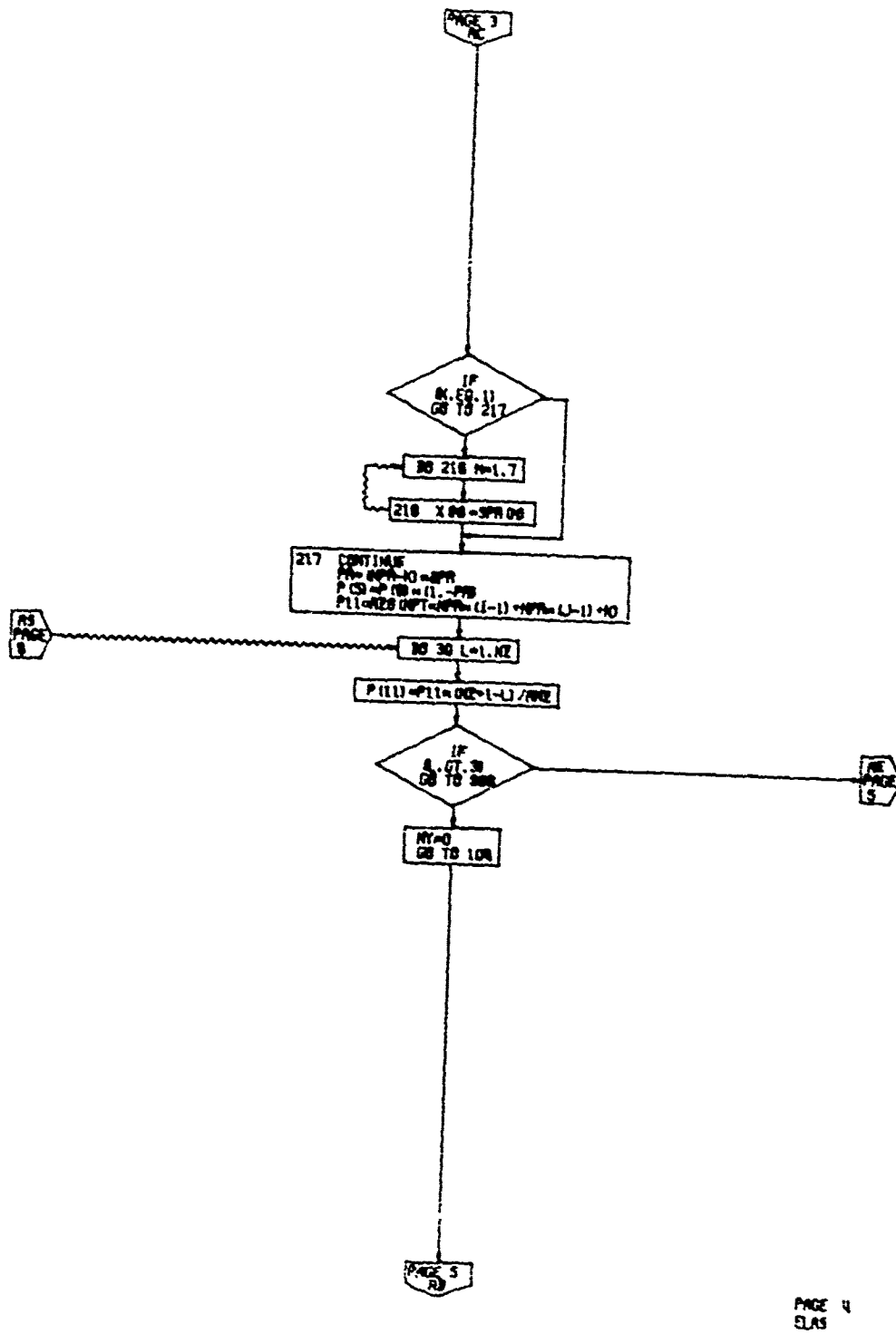

PAGE 4
ELAS

Table 19: FLOWCHART FOR SUBROUTINE ELAS (CONTINUED)

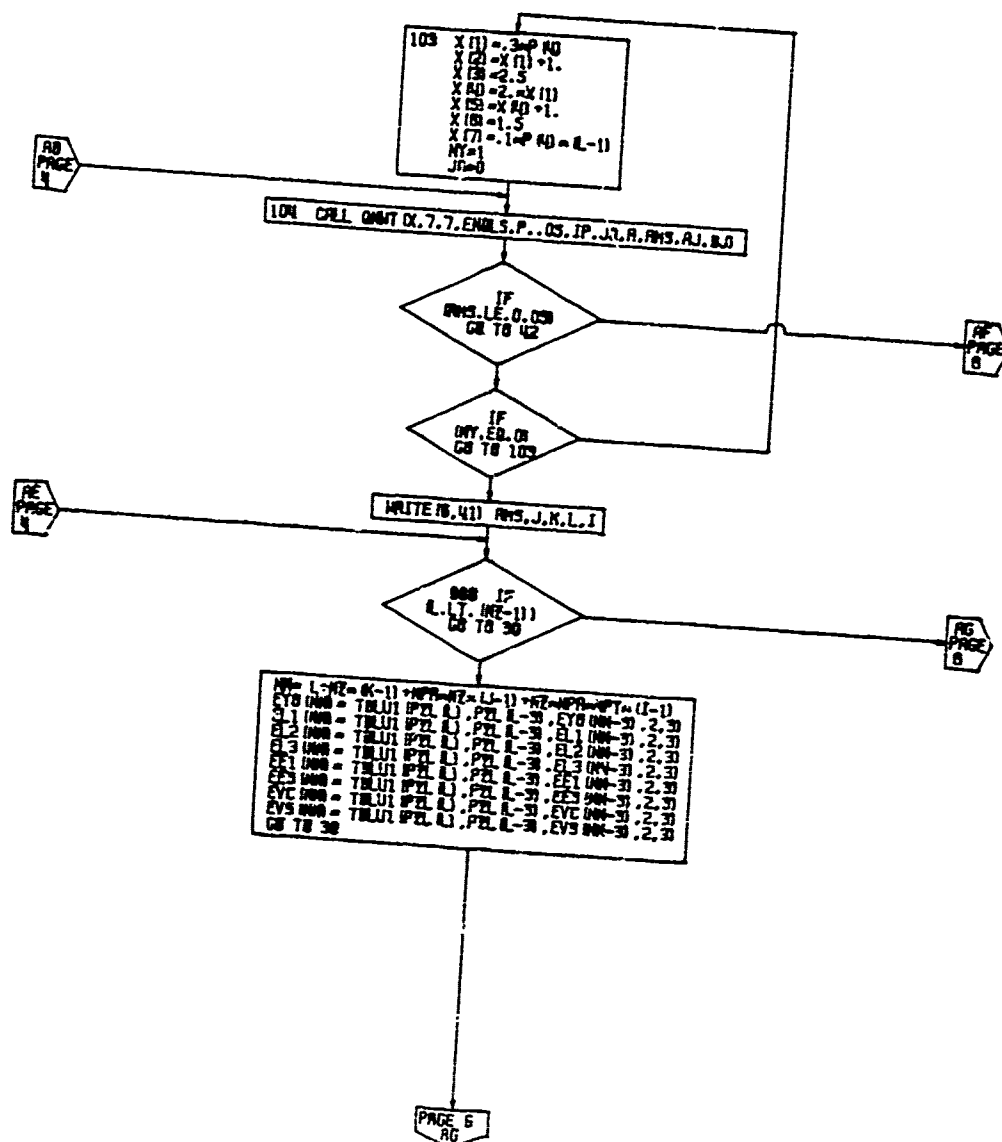

PAGE 5
ELAS

Table 19: FLOWCHART FOR SUBROUTINE ELAS (CONTINUED)

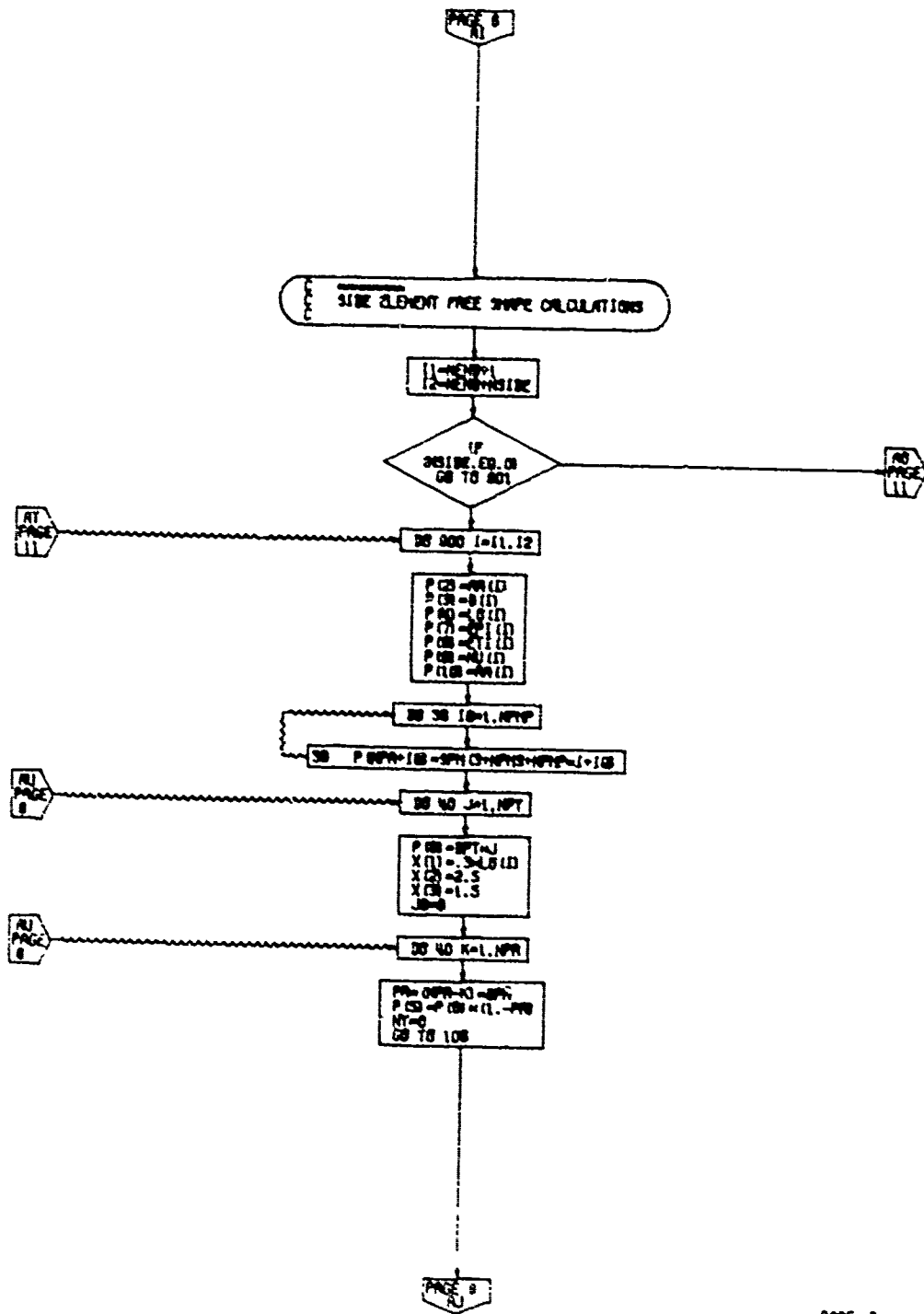

PAGE 7
ELAS

Table 19: FLOWCHART FOR SUBROUTINE ELAS (CONTINUED)

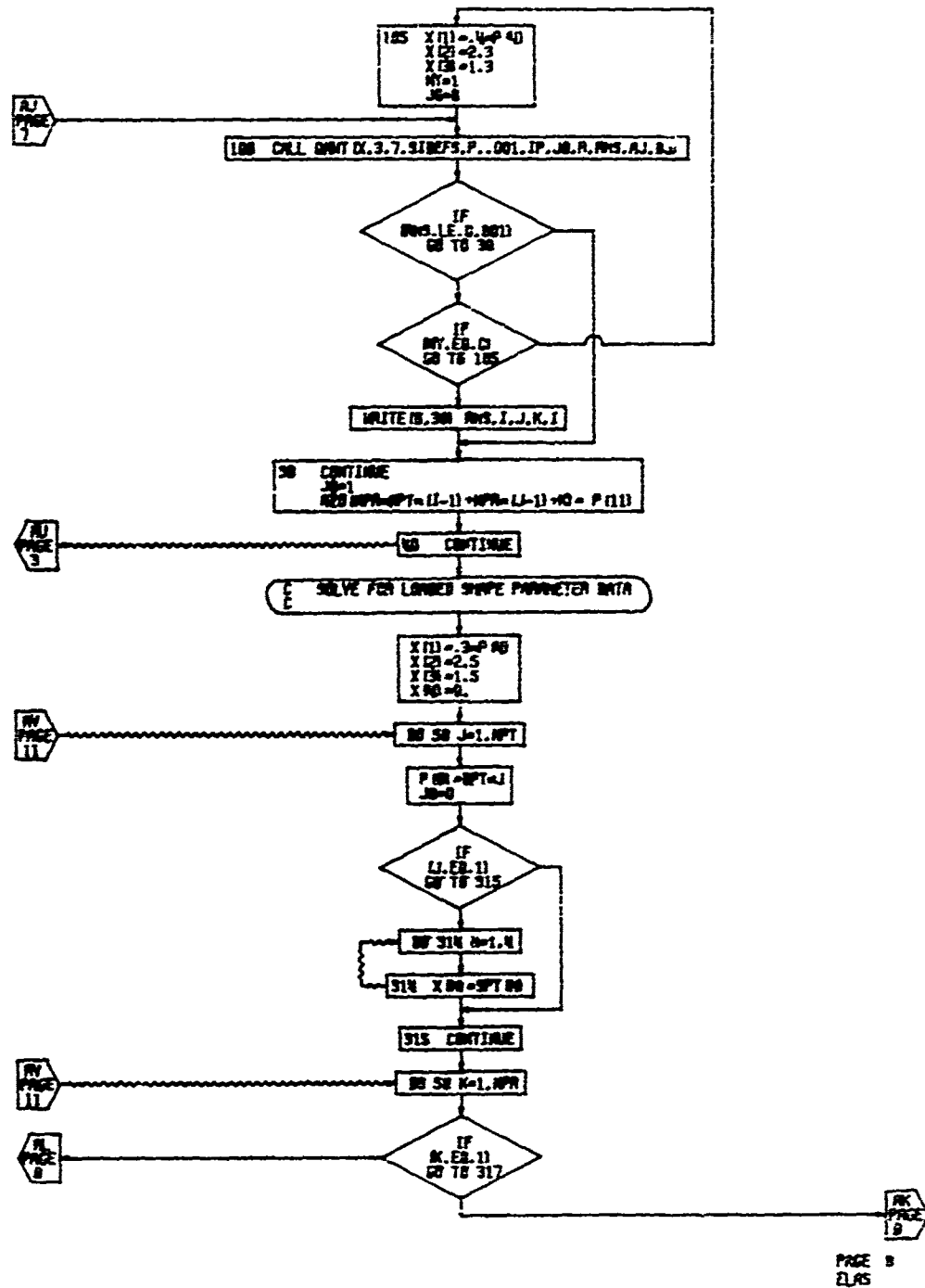
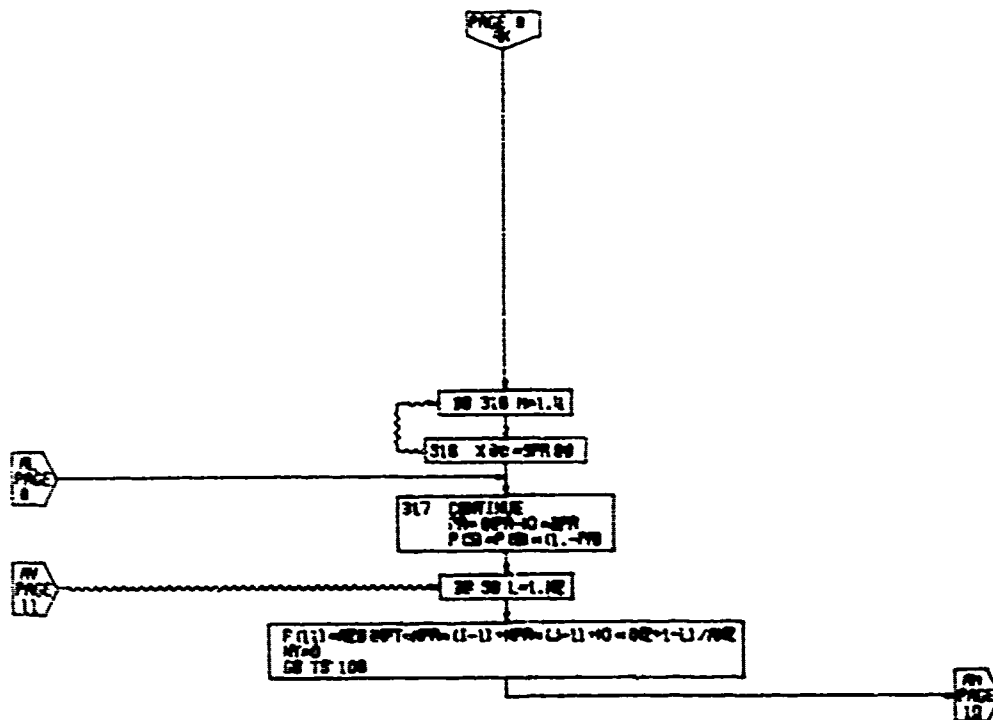

Table 19: FLOWCHART FOR SUBROUTINE ELAS (CONTINUED)



PAGE 9
ELAS

Table 19: FLOWCHART FOR SUBROUTINE ELAS (CONTINUED)

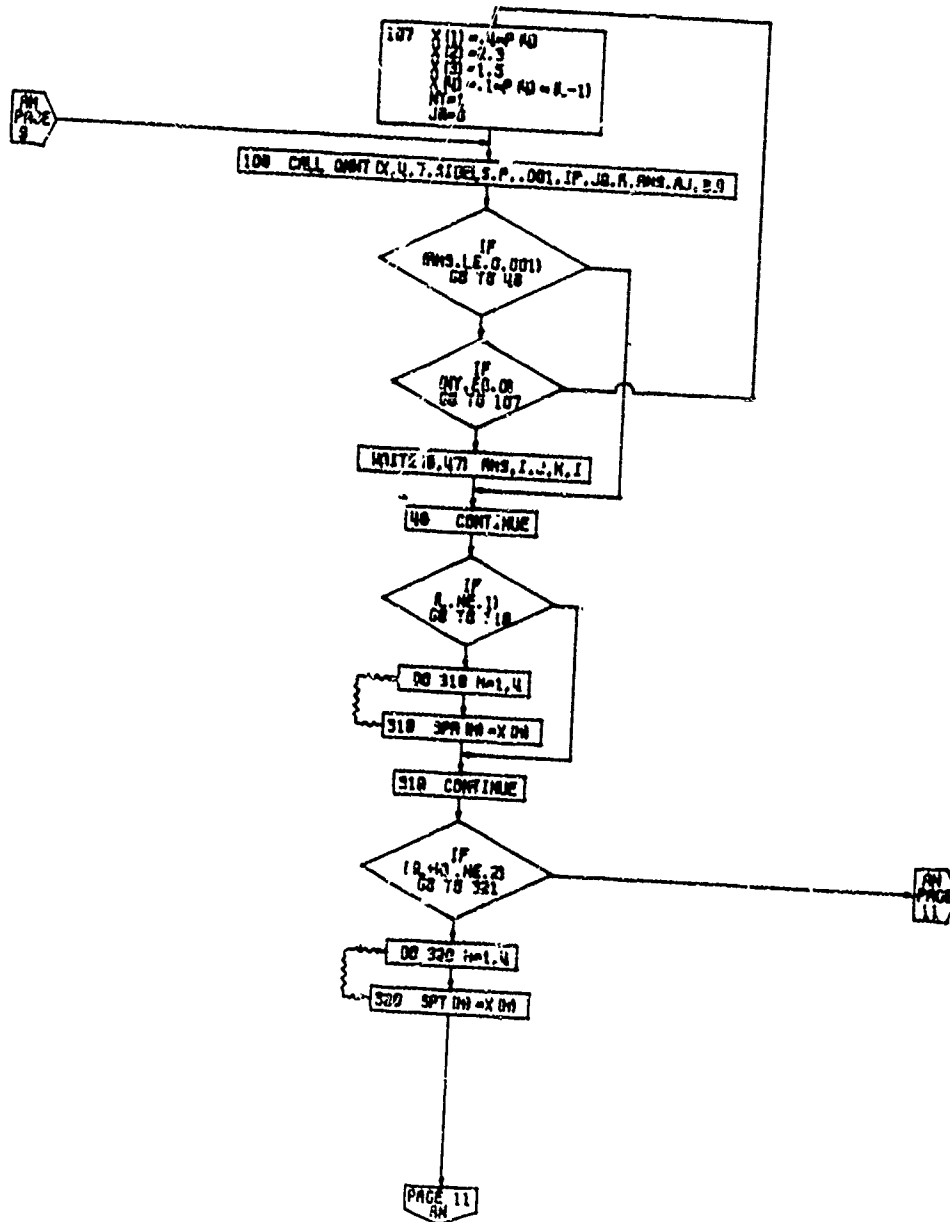
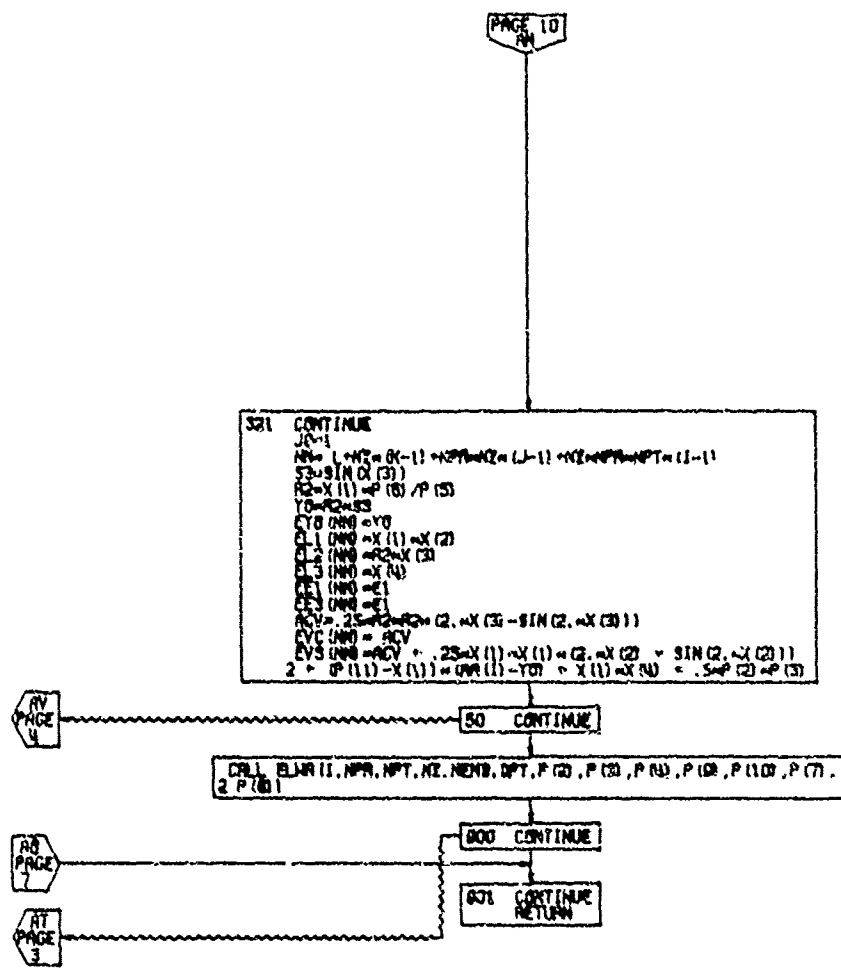
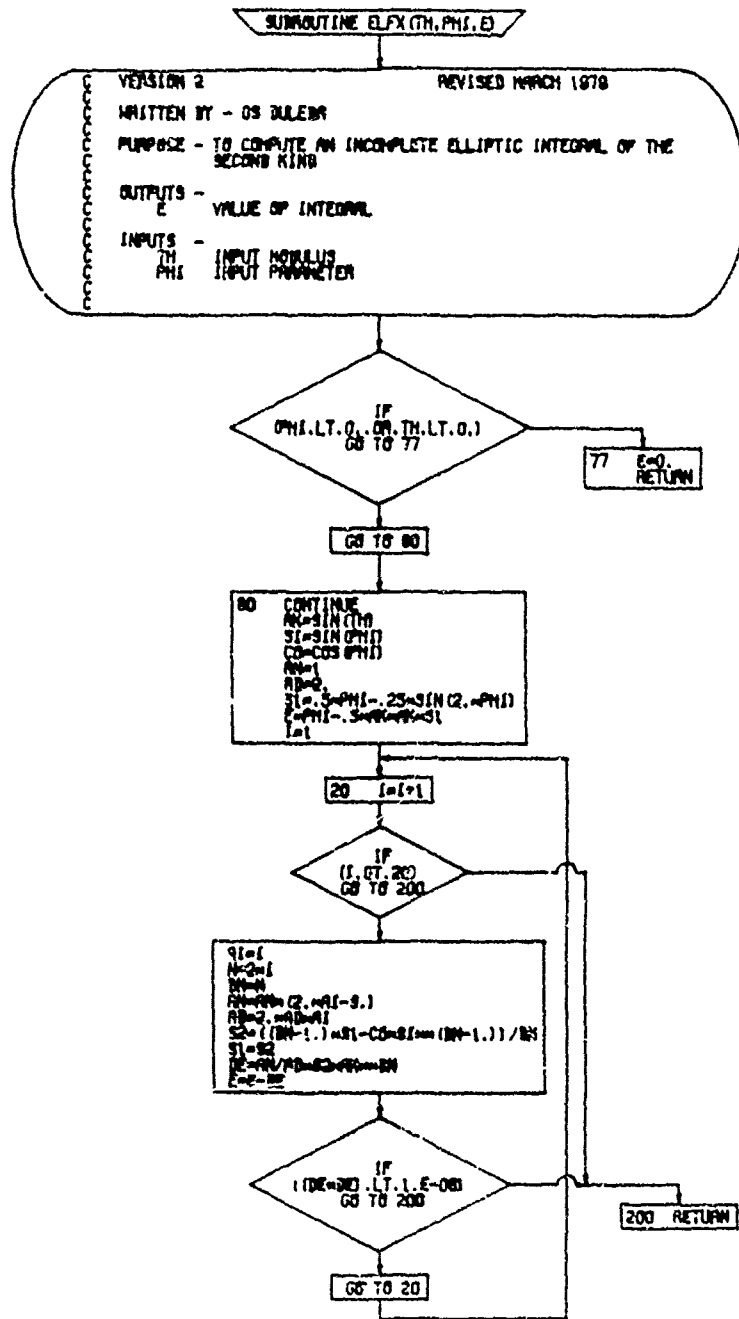

Table 19: FLOWCHART FOR SUBROUTINE ELAS (CONCLUDED)



PAGE 11
ELAS

Table 20: FLOWCHART FOR SUBROUTINE ELFX



PAGE 1
ELFX

Table 21: FLOWCHART FOR SUBROUTINE ELKX

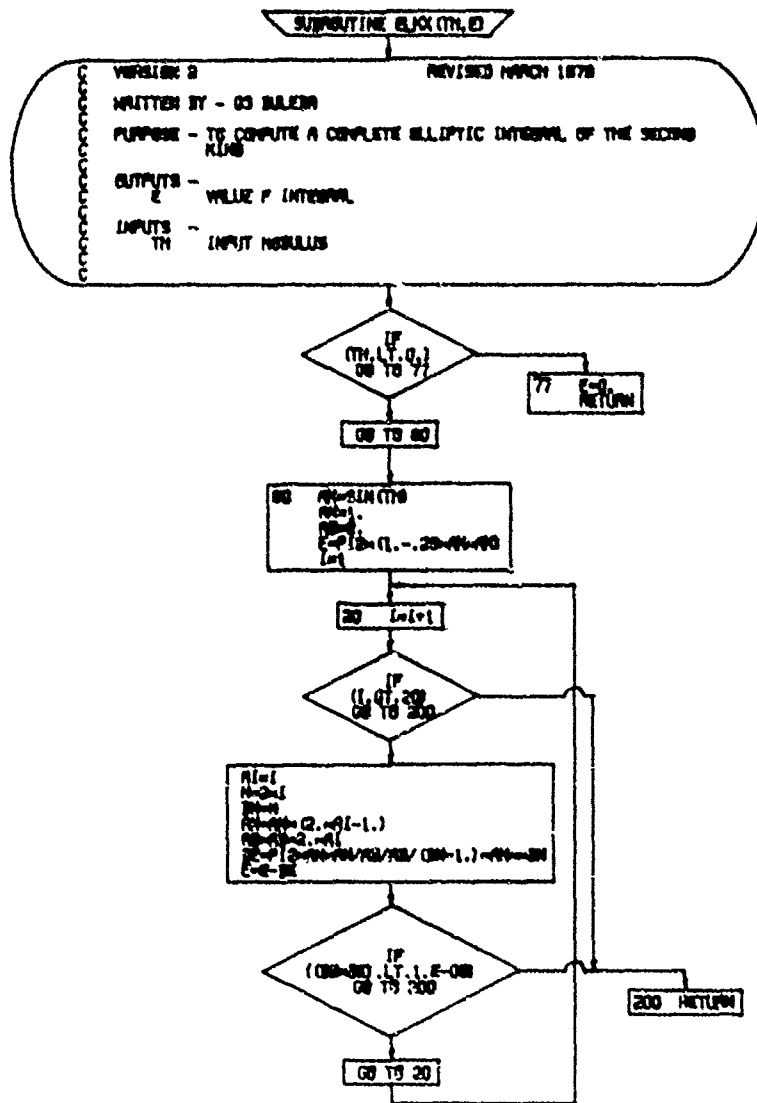

PAGE 1
ELKX

Table 22: FLOWCHART FOR SUBROUTINE ELWR

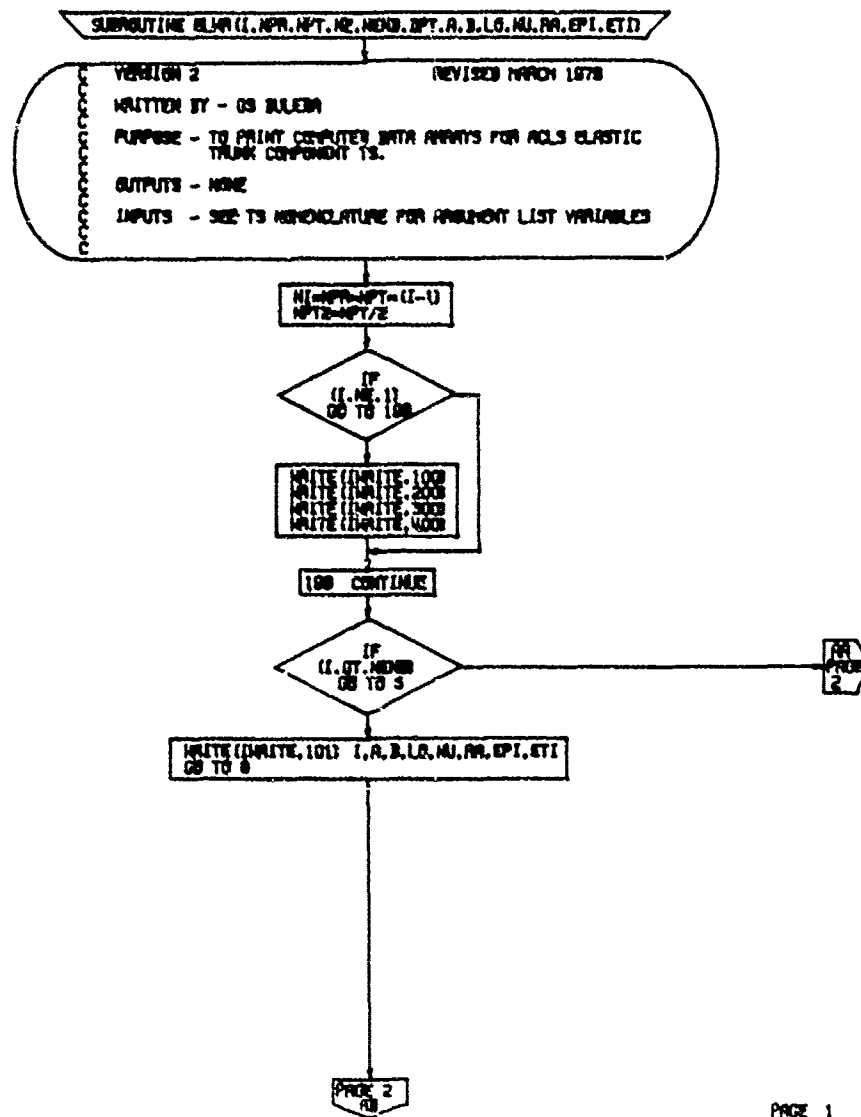

PAGE 1
ELWR

Table 22: FLOWCHART FOR SUBROUTINE ELWR (CONTINUED)

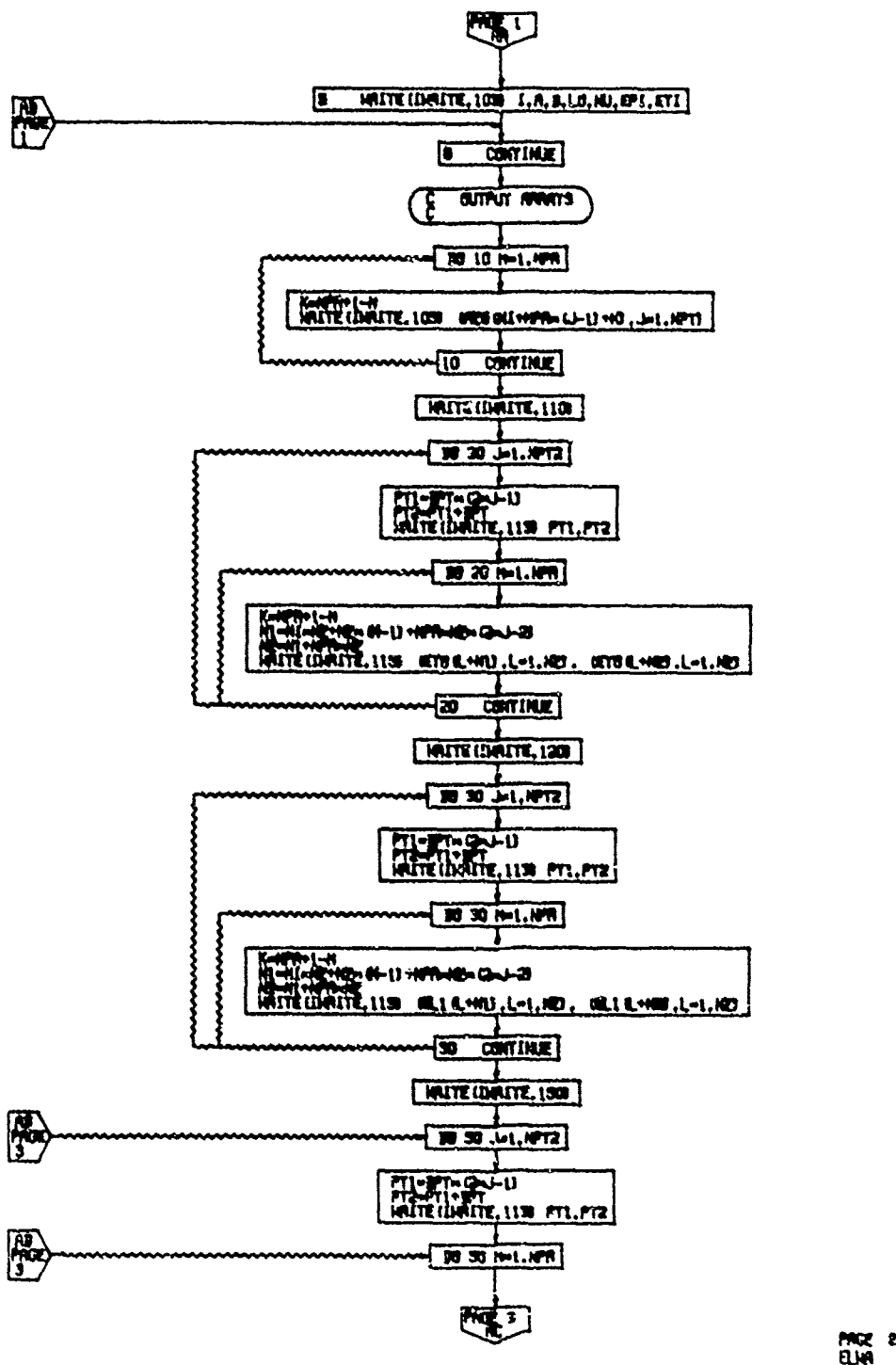
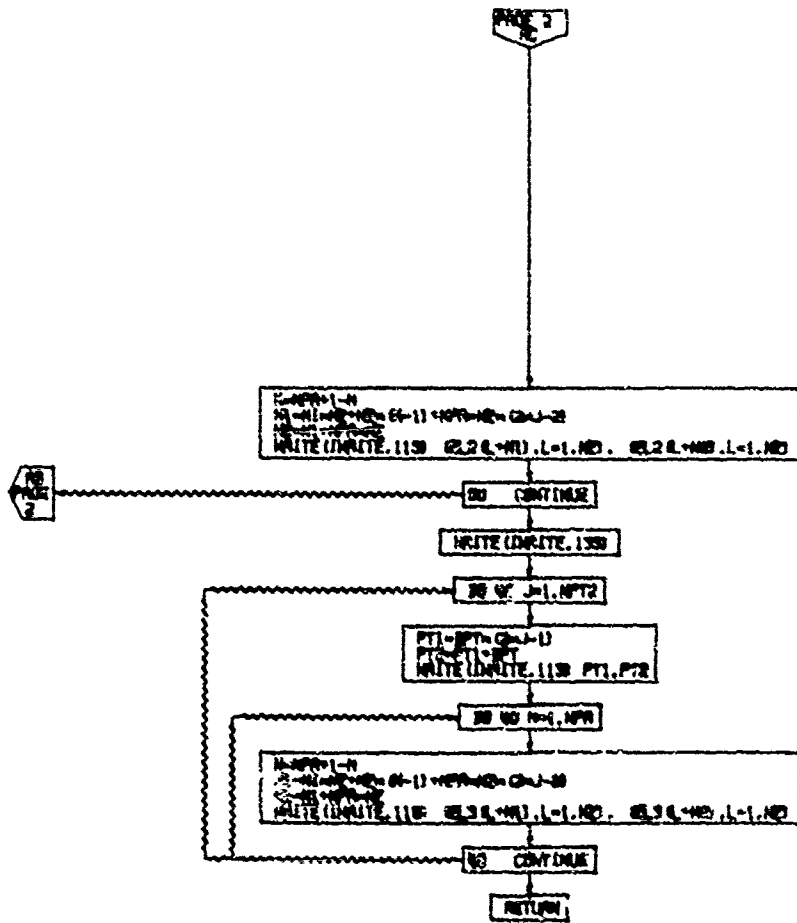

Table 22: FLOWCHART FOR SUBROUTINE ELWR (CONCLUDED)



PAGE 3
ELWR

Table 23: FLOWCHART FOR SUBROUTINE ENDF5

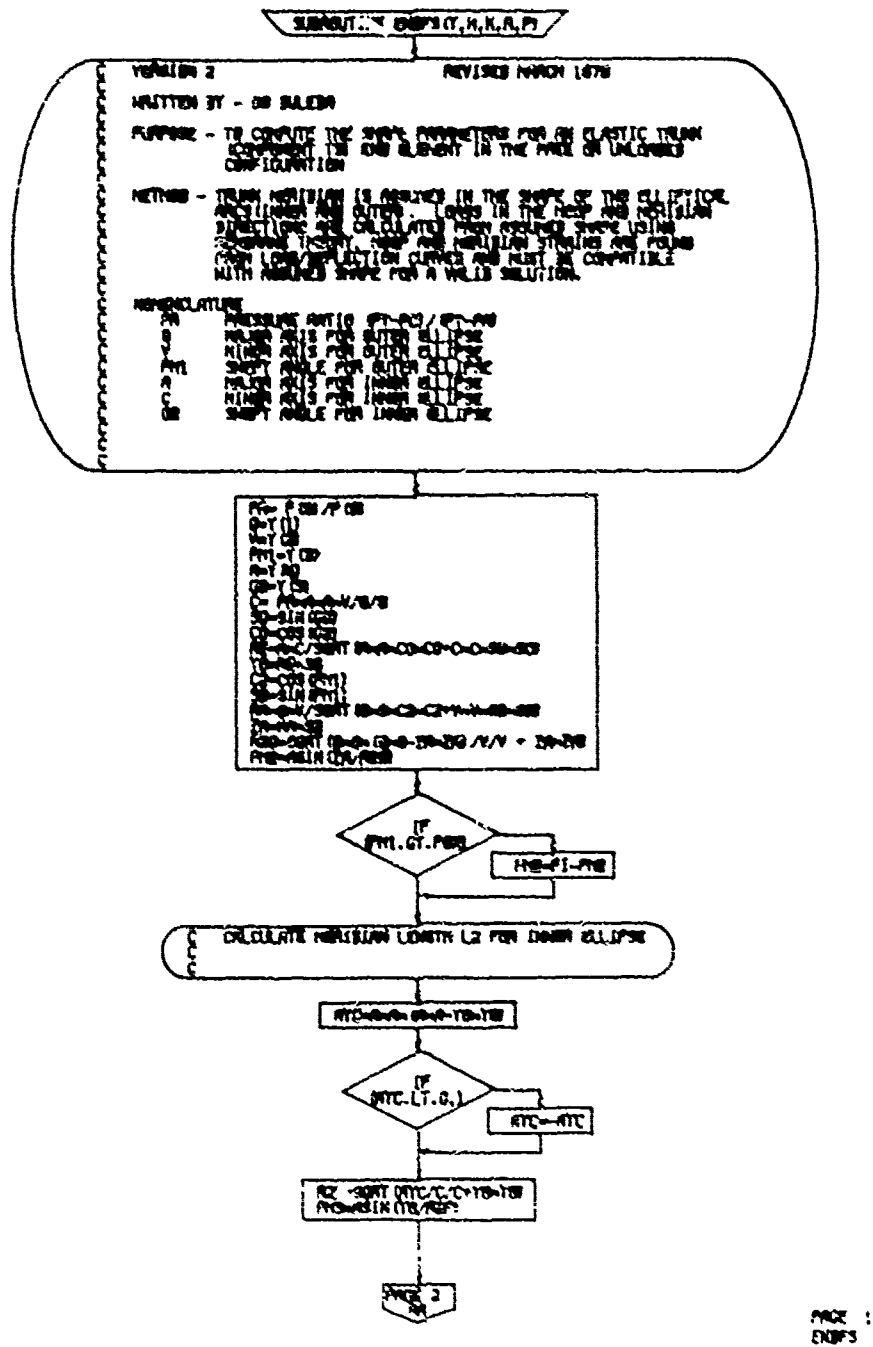
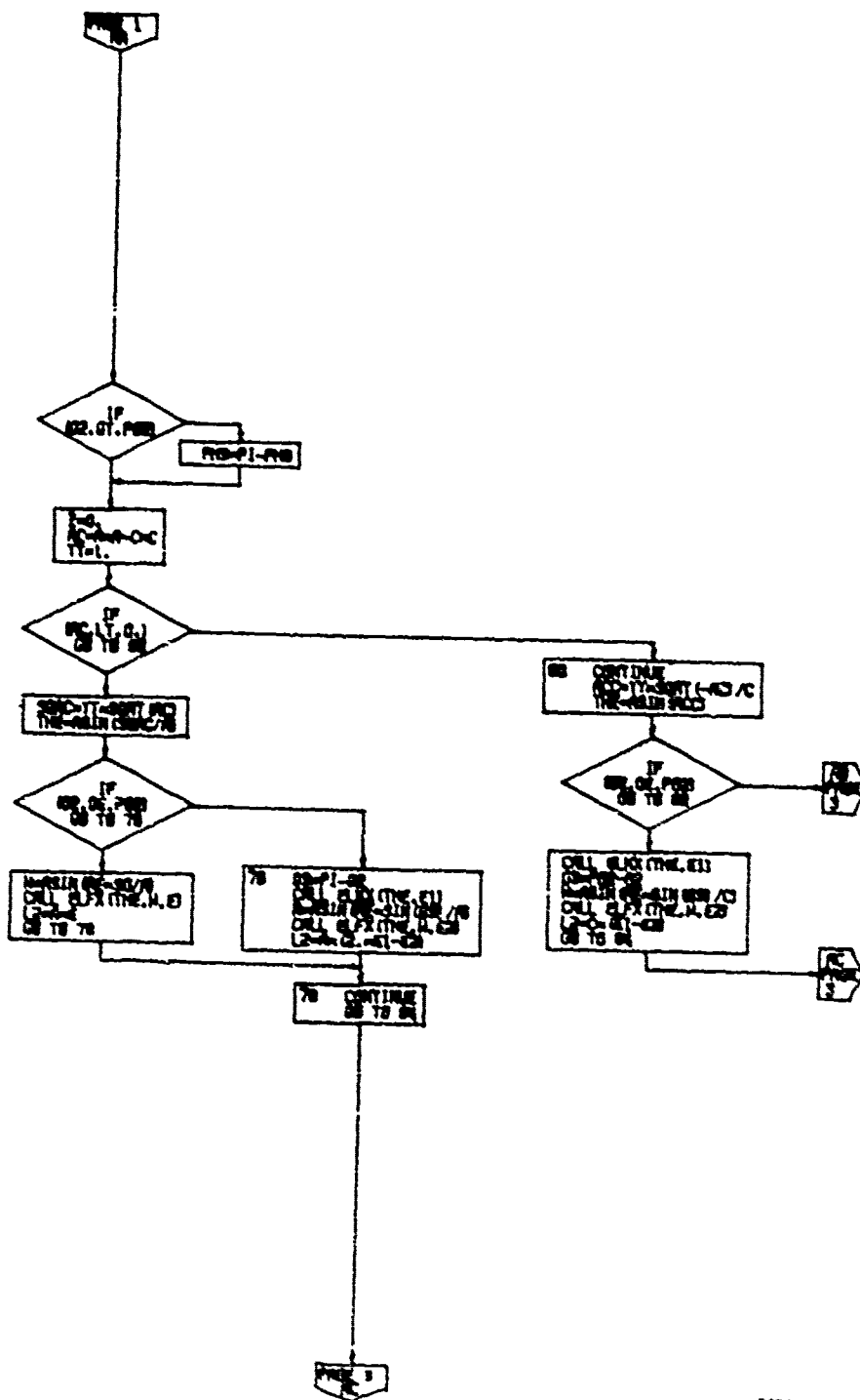
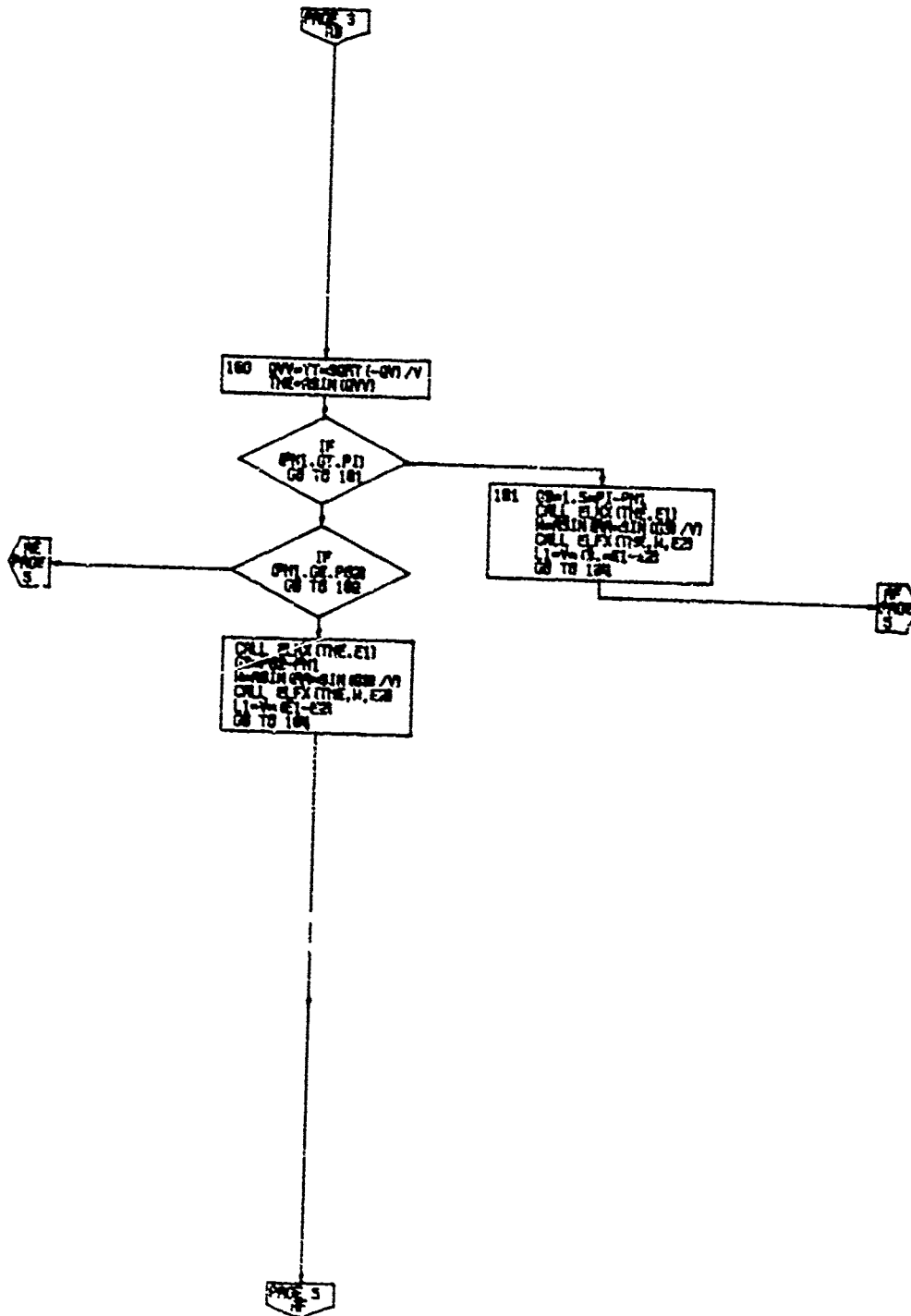

Table 23: FLOWCHART FOR SUBROUTINE ENDF3 (CONTINUED)



PAGE 2
ENDF3

Table 23: FLOWCHART FOR SUBROUTINE ENLFS (CONTINUED)



PAGE 6
ENLFS

Table 23: FLOWCHART FOR SUBROUTINE ENDFS (CONTINUED)

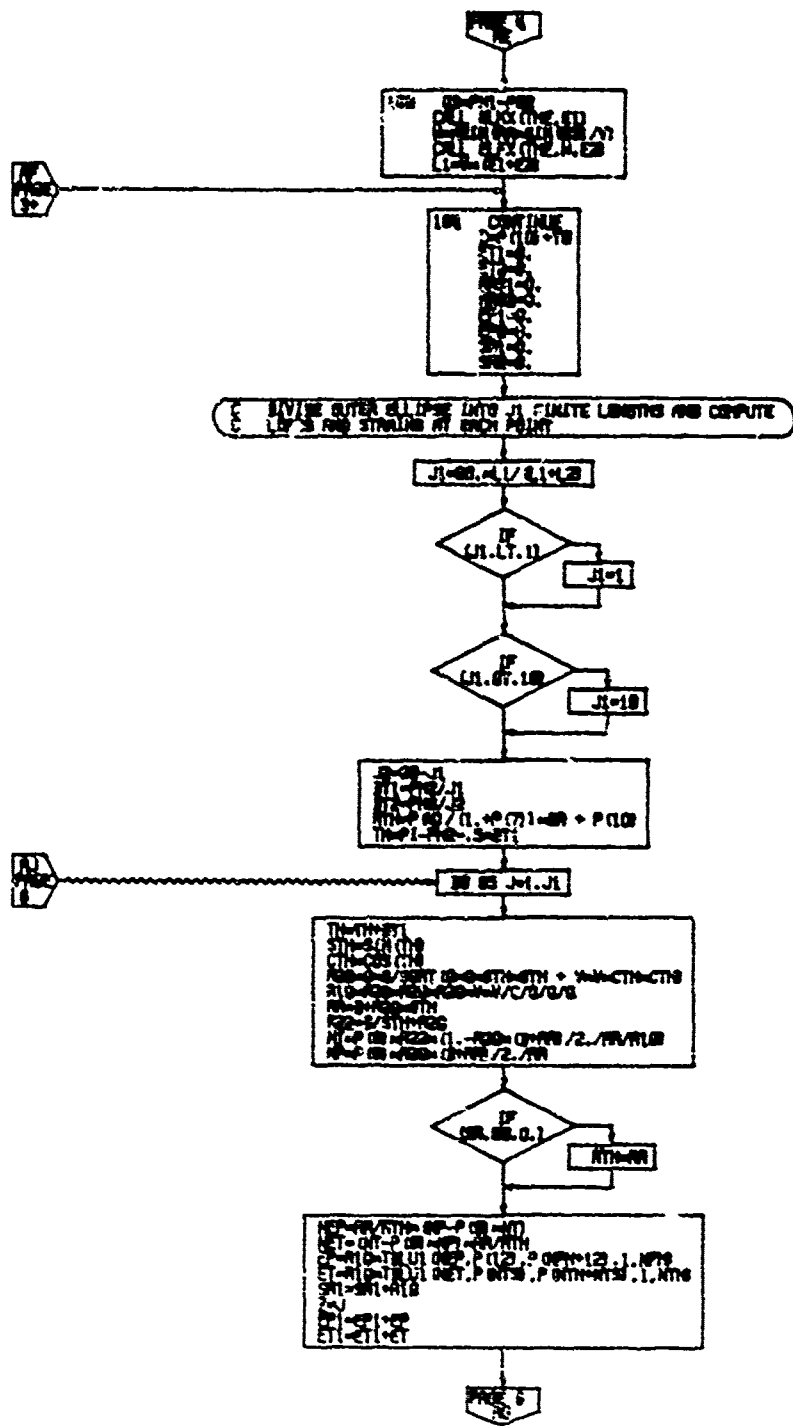
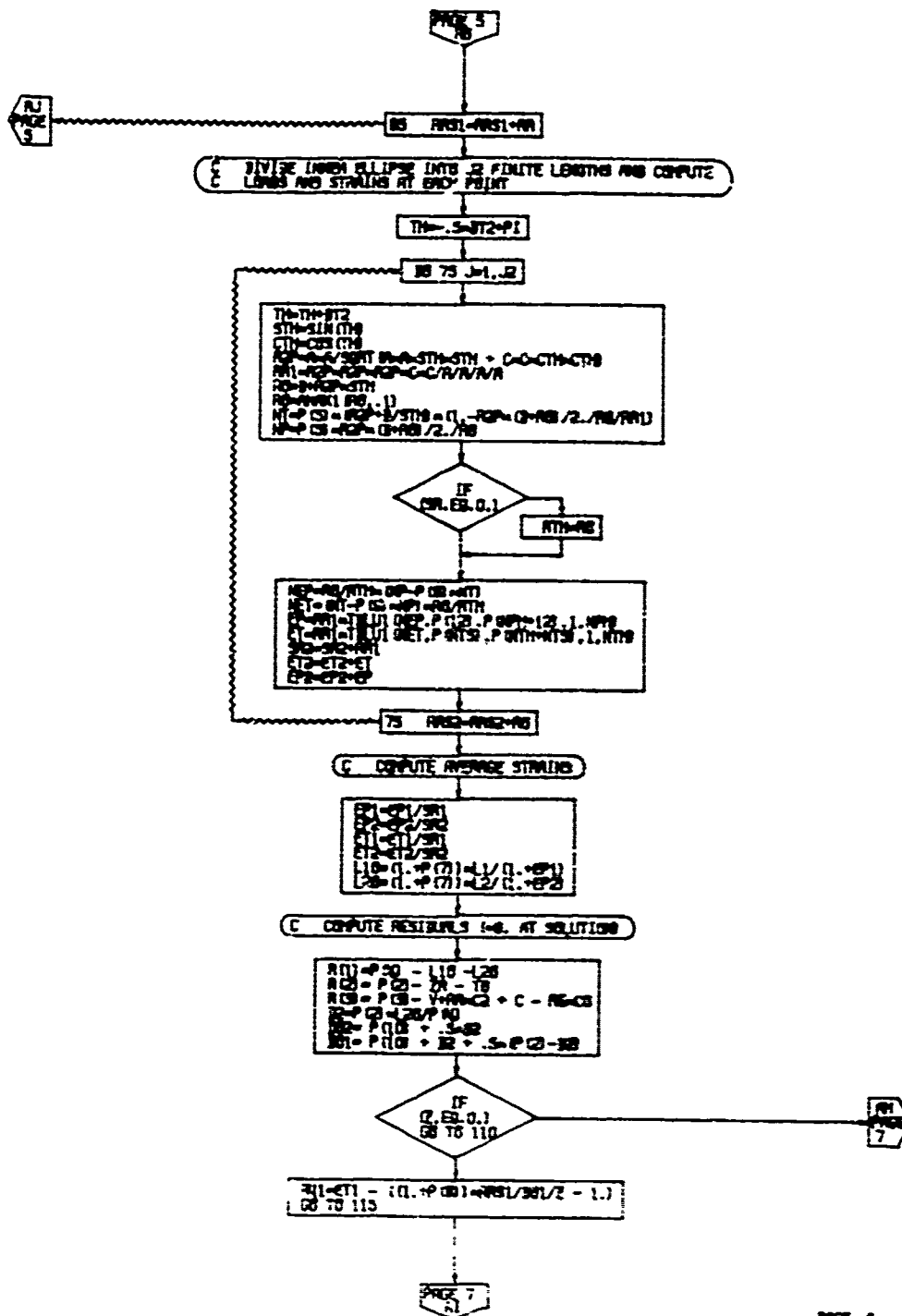

Table 23: FLOWCHART FOR SUBROUTINE ENDFS (CONTINUED)



PAGE 5
ENDFS

Table 23: FLOWCHART FOR SUBROUTINE ENDF (CONCLUDED)

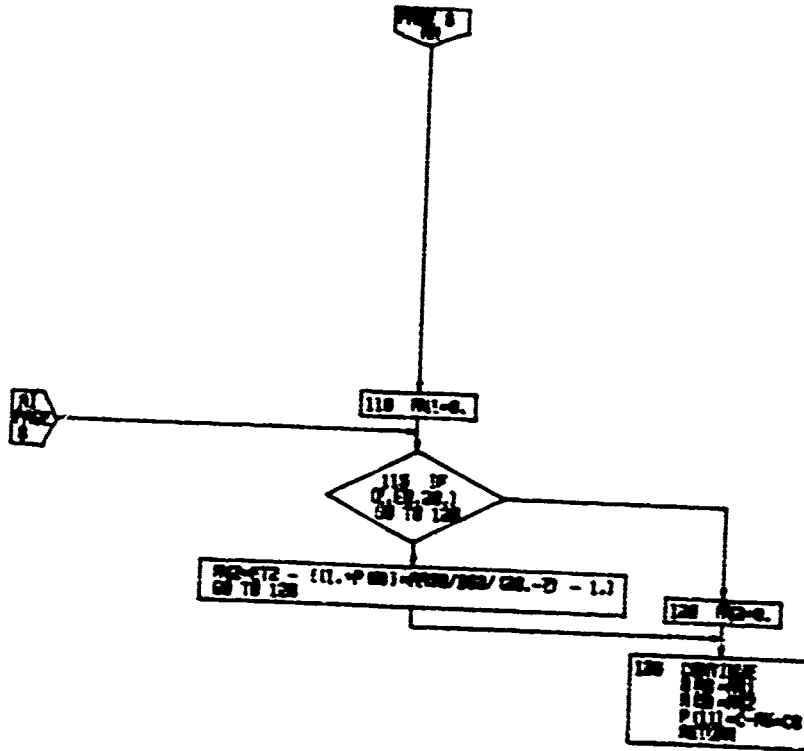
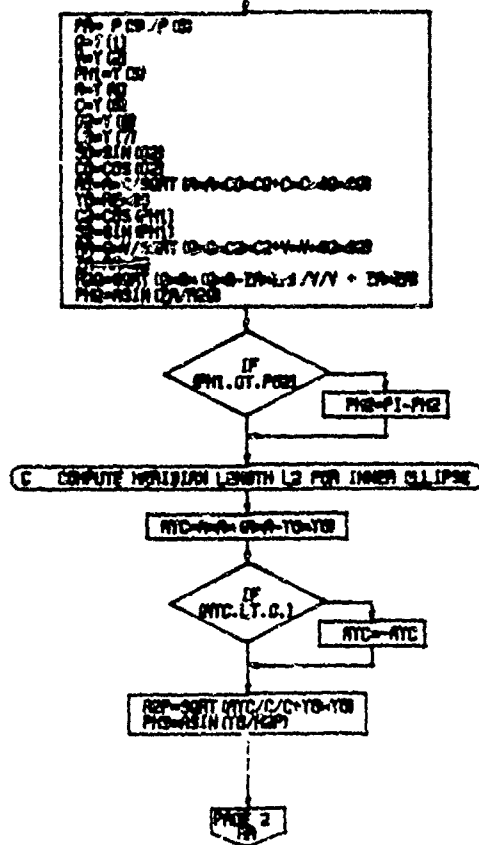
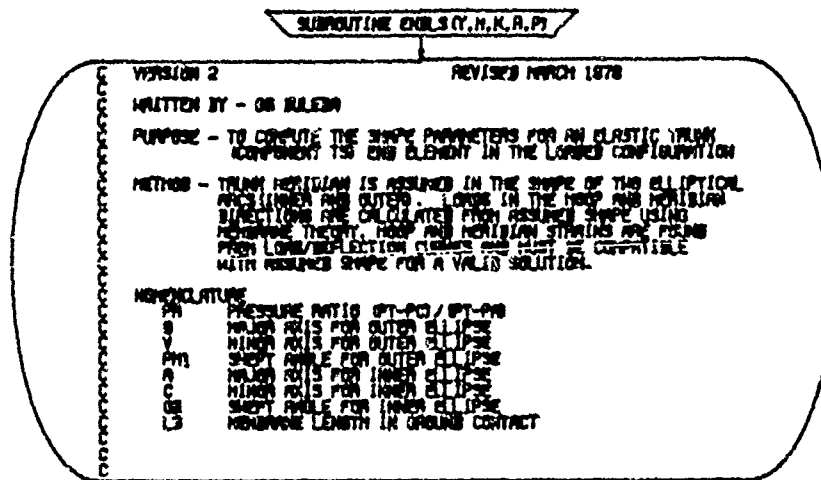
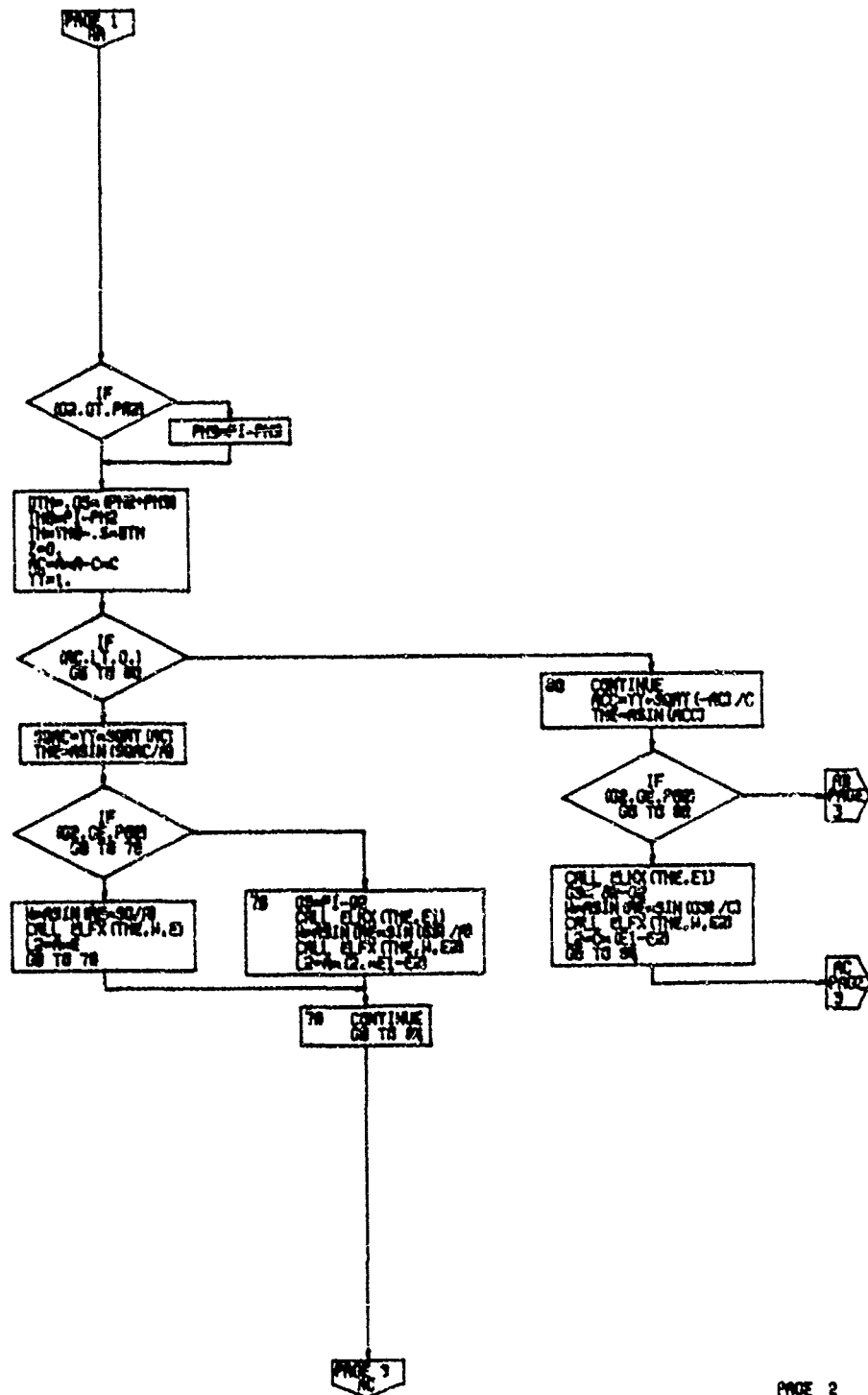

Table 24: FLOWCHART FOR SUBROUTINE ENCLS



PAGE 1
ENCLS

Table 24: FLOWCHART FOR SUBROUTINE ENCLS (CONTINUED)



PAGE 2
FWR 5

Table 24: FLOWCHART FOR SUBROUTINE ENCLS (CONTINUED)

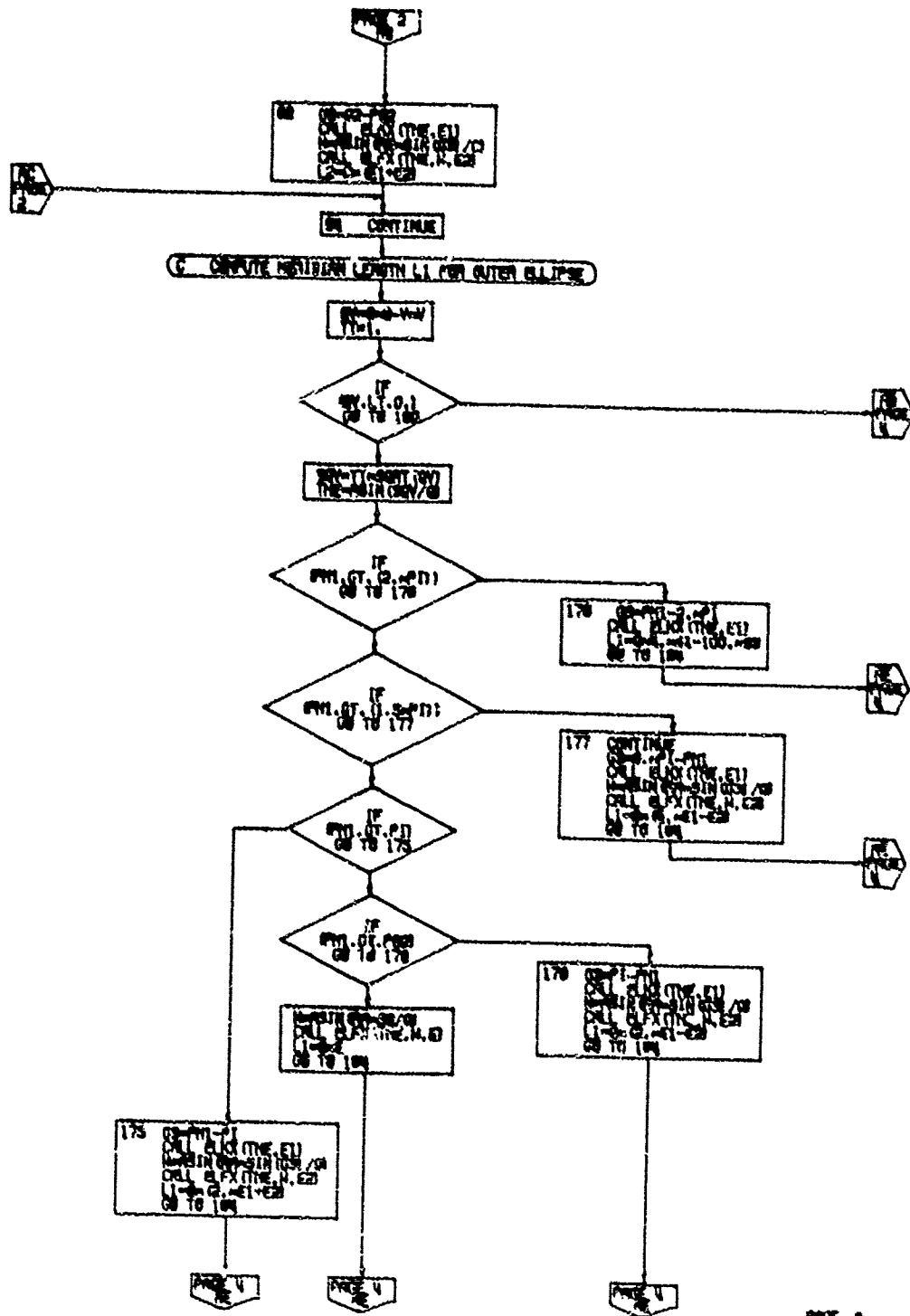

PAGE 9
ENCLS

Table 24: FLOWCHART FOR SUBROUTINE ENCLS (CONTINUED)

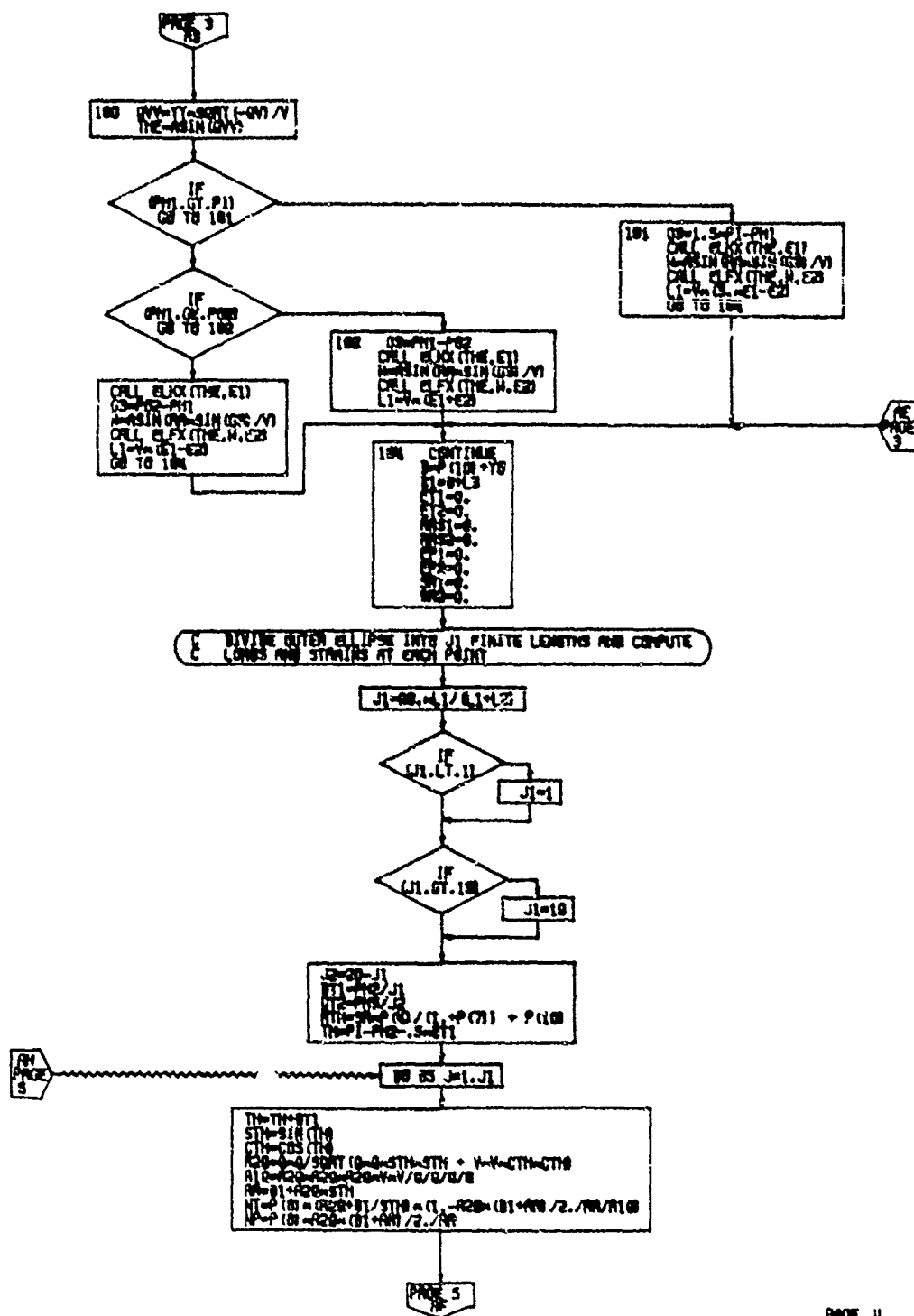

PAGE 4
ENCLS

Table 24: FLOWCHART FOR SUBROUTINE ENCLS (CONTINUED)

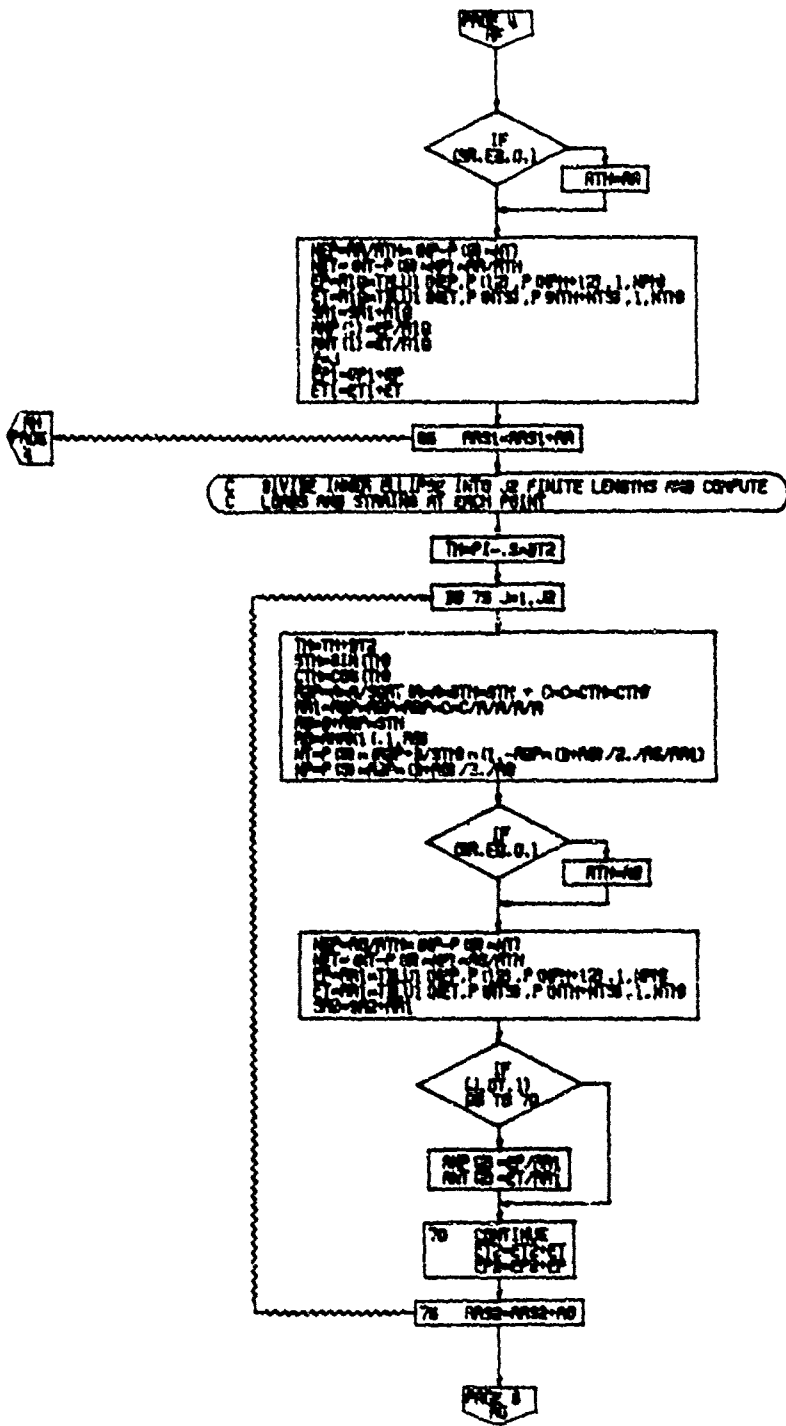
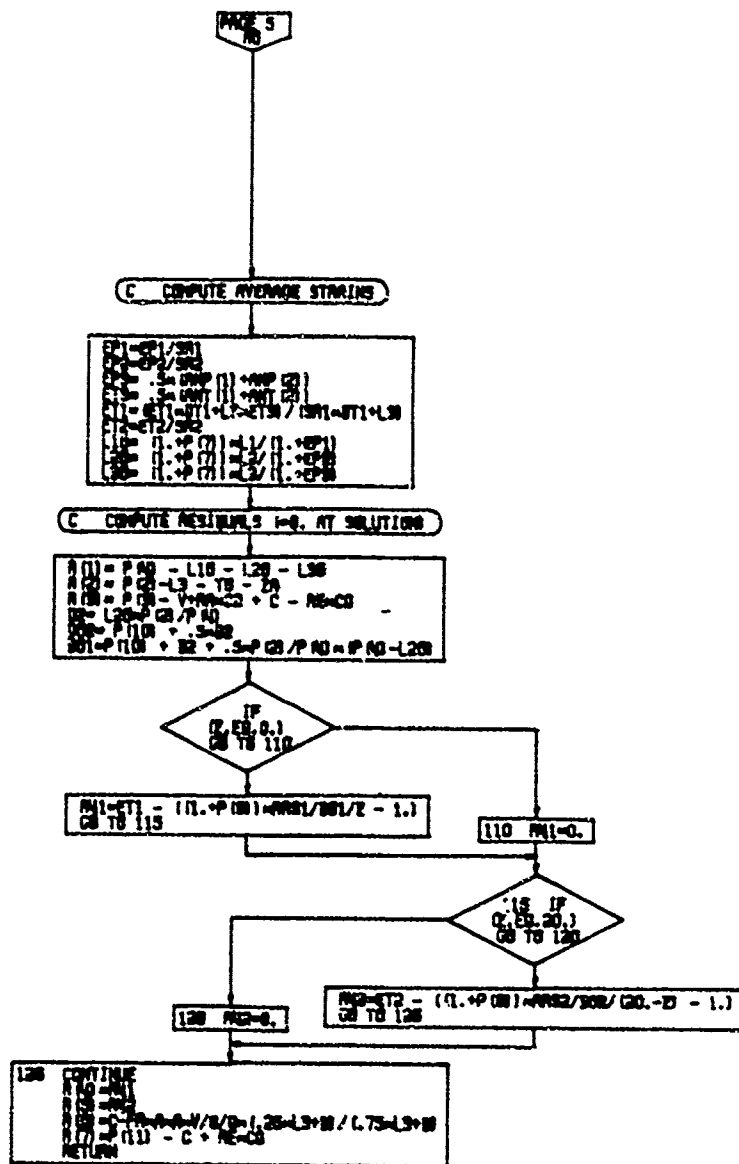

Table 24: FLOWCHART FOR SUBROUTINE ENDS (CONCLUDED)



PAGE 6
ENDS

Table 25: FLOWCHART FOR SUBROUTINE ES

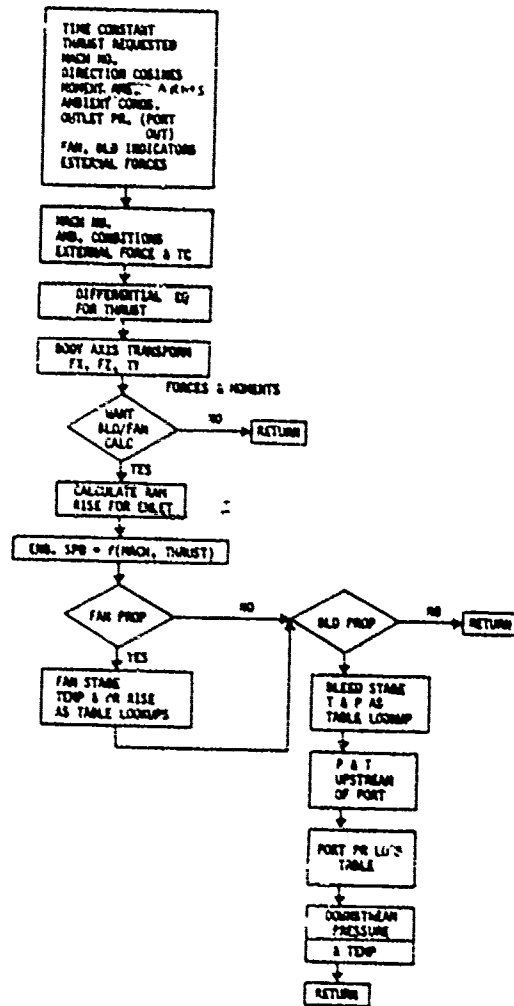

Table 26: FLOWCHART FOR SUBROUTINE ETB2

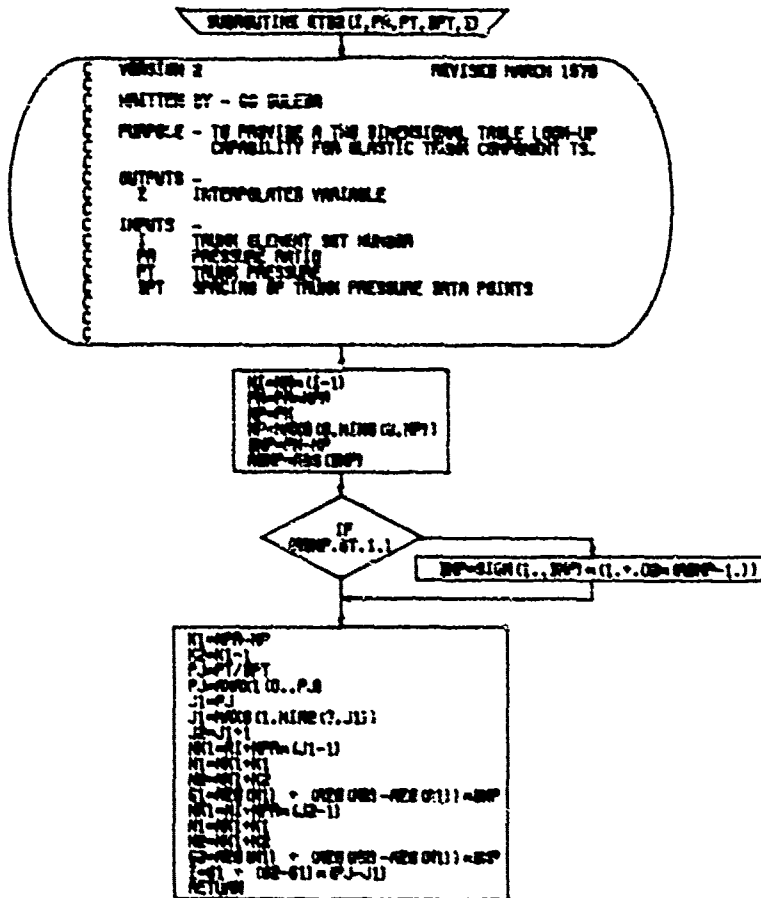
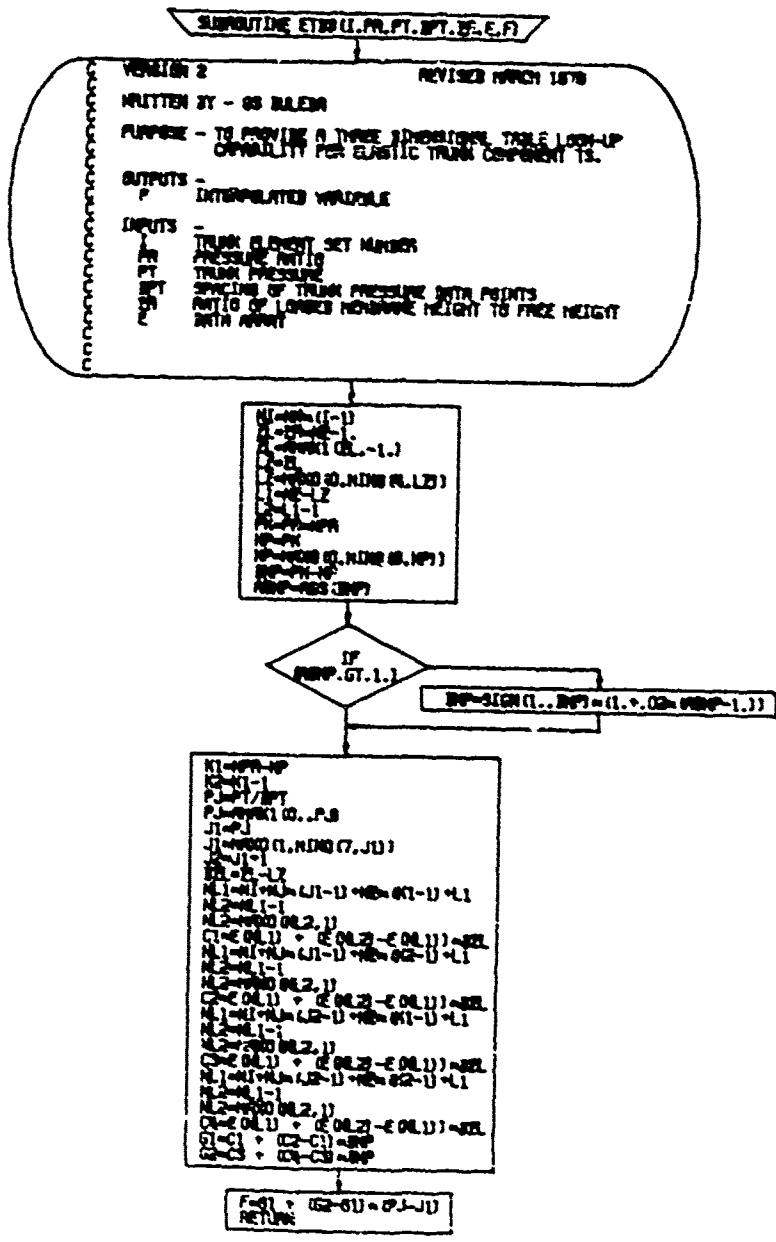
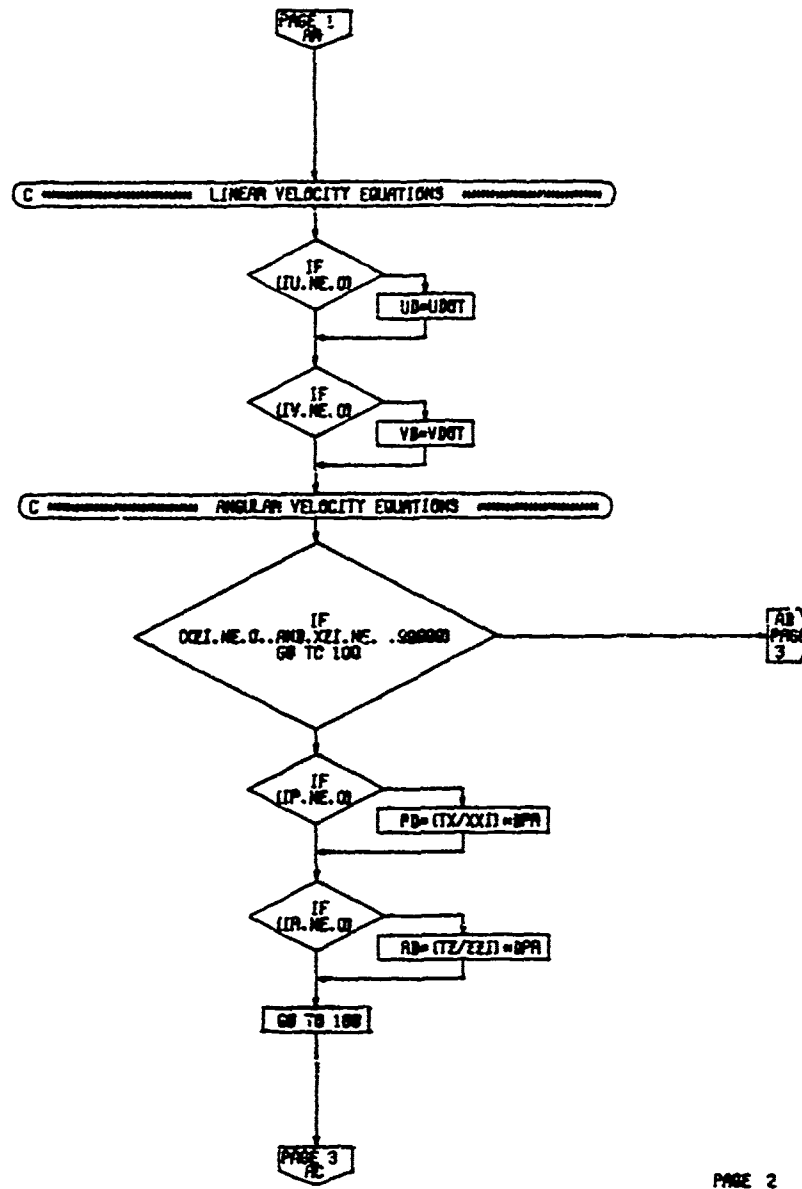

Table 27: FLOWCHART FOR SUBROUTINE ETB3



1
2
3

Table 28: FLOWCHART FOR SUBROUTINE FD (CONTINUED)



PAGE 2
FD

Table 28: FLOWCHART FOR SUBROUTINE FD (CONTINUED)

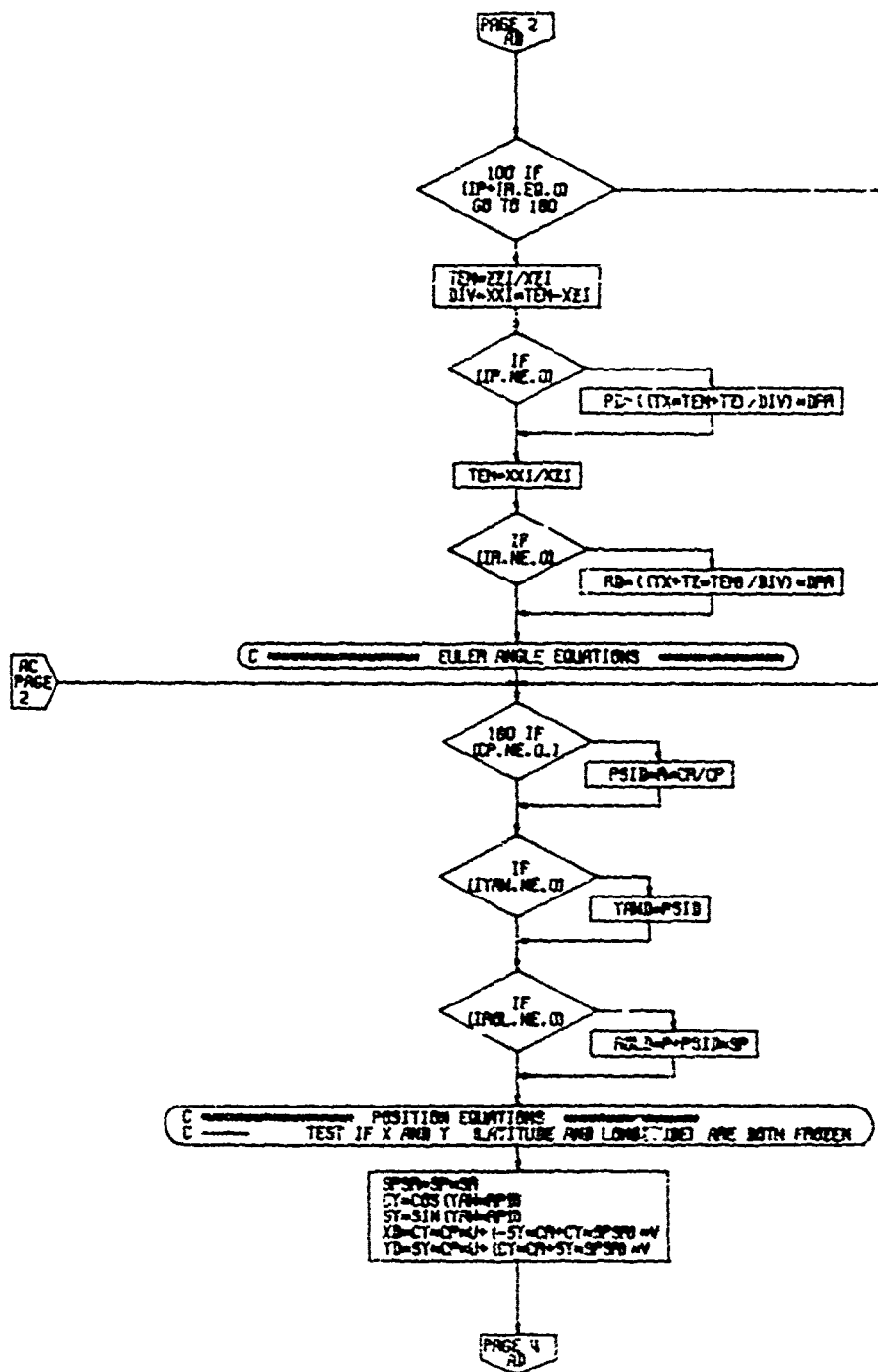

Table 28: FLOWCHART FOR SUBROUTINE FD (CONCLUDED)

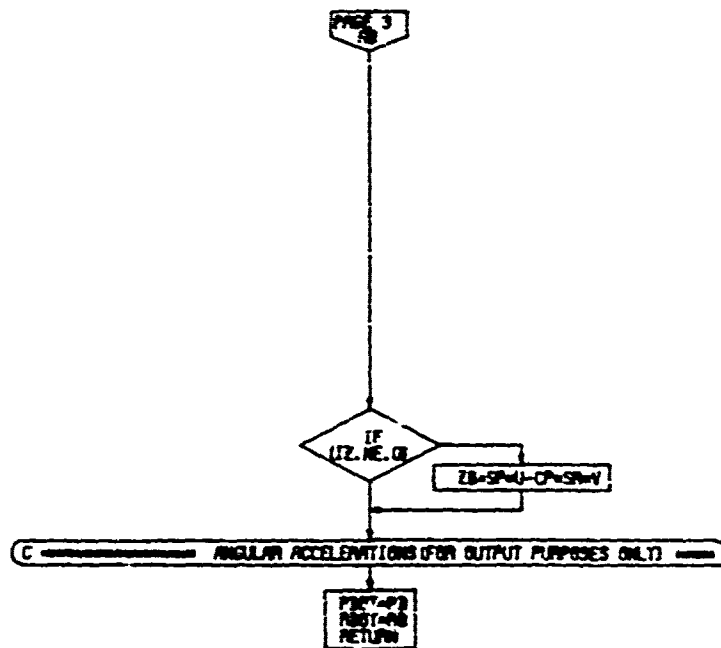

Table 29: FLOWCHART FOR SUBROUTINE FG

SUBROUTINE FS,FB,FBRT,IFB,FIN,G1,NO1,NO2,NO3

VERSION 1.

PURPOSE - SIMULATION OF A SIMPLE GENERAL PURPOSE FLIGHT AND CRASH CONTROLLER FOR AIRCRAFT

METHOD - SEE CSBING

CALL SEQUENCE

OUTPUTS

FB - CONTROLLER OUTPUT
 FBRT - OUTPUT DERIVATIVE
 IFB - INTEGRATOR CONTROL

INPUTS

FIN - COMMAND SIGNAL
 G1 - GAIN(SLOPE) FOR COMMAND SIGNAL INPUT
 NO1 - UPPER LIMIT OF SATURATION ON COMMAND SIGNAL INPUT
 NO2 - LOWER LIMIT OF SATURATION ON COMMAND SIGNAL INPUT
 G2 - LOW GAIN(SLOPE) FOR THE INTEGRATOR
 NO3 - UPPER LIMIT OF SATURATION ON OUTPUT
 NO4 - LOWER LIMIT OF SATURATION ON OUTPUT

WRITTEN BY: MURKINER WALK SEPT 1977

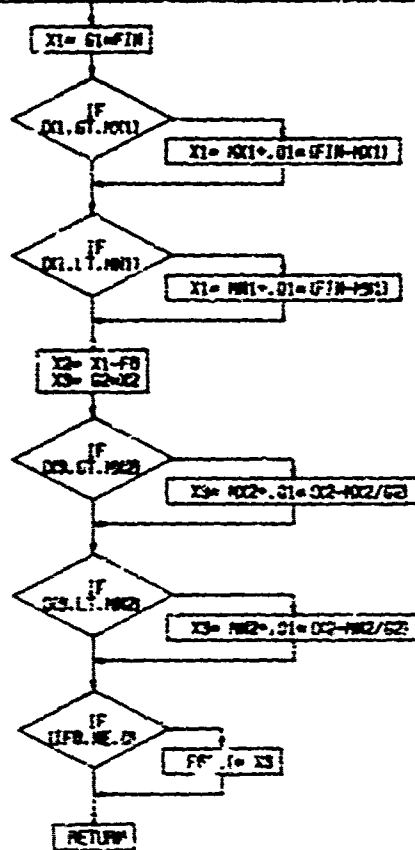

77 78 1

Table 30: FLOWCHART FOR SUBROUTINE FH

SUBROUTINE FH (CF, CR, T2, WC, WCDOT, INC, P1, P1DOT, IP1, T1, H1,
I, P2, PWR, PWS, TC)

VERSION 1. SEPT. 1, 1977
 PURPOSE - FAN MODEL WITH TRANSITION BETWEEN STALL AND RECOVERY
 METHOD - IT IS ASSUMED THAT TRANSITION FROM NORMAL TO STALLED OPERATION OCCURS WHEN THE PRESSURE RATIO EXCEEDS THE STALL PRESSURE RATIO AND THAT TRANSITION FROM STALLED TO NORMAL OCCURS WHEN PRESSURE RATIO FALLS BELOW A REVERSE PRESSURE RATIO.
 CALL SEQUENCE
 TABLES
 CF - FAN FLOW RATE (FORWARD) AS A FUNCTION OF FAN PRESSURE RATIO, ONE DIMENSIONAL TABLE
 CR - FAN FLOW RATE (REVERSE) AS A FUNCTION OF FAN PRESSURE RATIO, ONE DIMENSIONAL TABLE
 OUTPUTS
 WC - FAN FLOW RATE, L./MIN
 WCDOT - FAN FLOW RATE DERIVATIVE, L./MIN/SEC
 INC - INTEGRATION CONTROL FOR WC
 P1 - INLET PRESSURE (PORT NO. 1), PSIA
 P1DOT - INLET PRESSURE DERIVATIVE, PSIA/SEC
 IP1 - INTEGRATION CONTROL ON P1
 T2 - OUTLET TEMPERATURE (PORT NO. 2), DEGR
 INPUTS
 P2 - OUTLET PRESSURE (PORT NO. 2), PSIA

H1 - INLET FLOW RATE (PORT NO. 1), L./MIN
 T1 - INLET TEMPERATURE (PORT NO. 1), DEGR
 PWR - PRESSURE RATIO BELOW WHICH TRANSITION FROM STALLED TO NORMAL OPERATION OCCURS
 PWS - PRESSURE RATIO ABOVE WHICH TRANSITION FROM NORMAL TO STALLED OPERATION OCCURS
 TC - FAN TIME CONSTANT

WRITTEN BY: MONTYDEN WANE SEPT. 1977

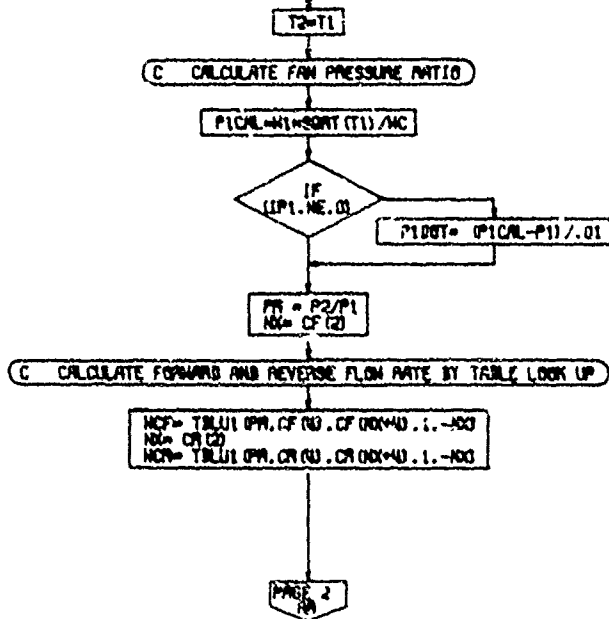

PAGE 1
FH

Table 30: FLOWCHART FOR SUBROUTINE FH (CONCLUDED)

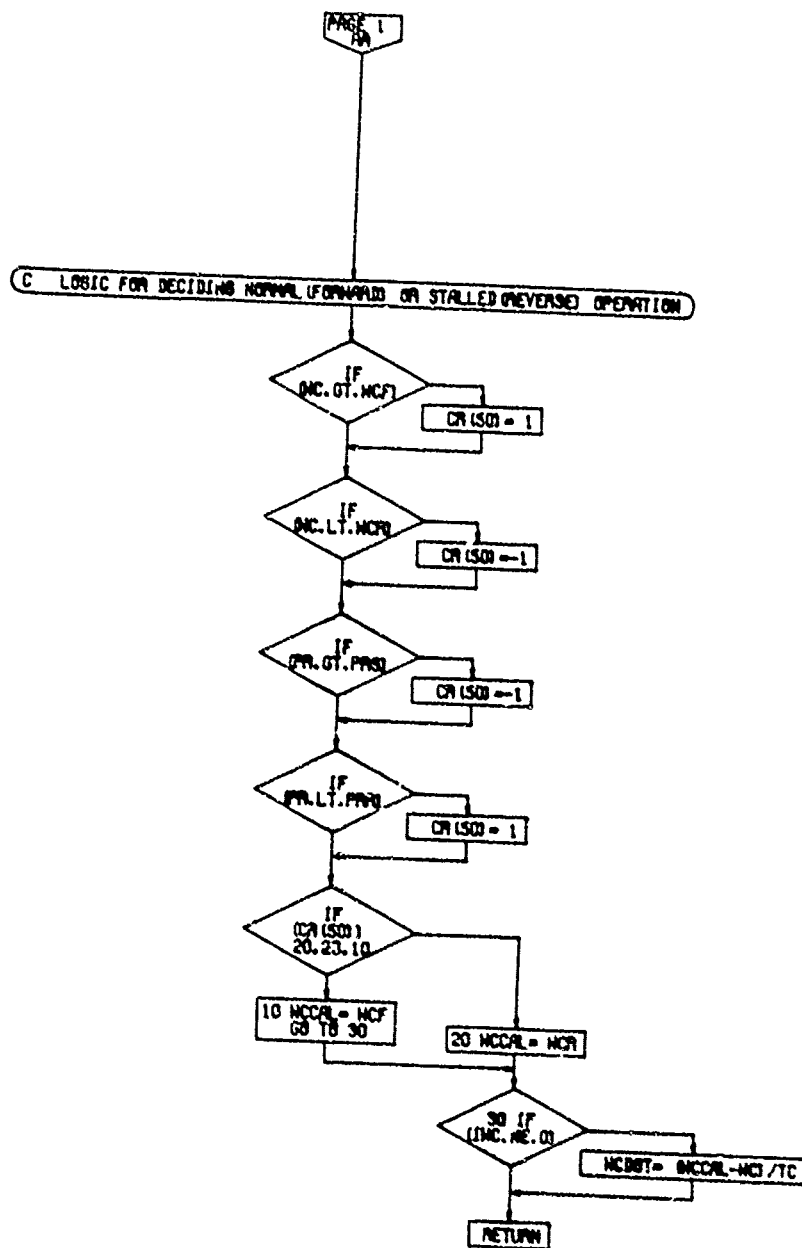

PAGE 2
FH

Table 31: FLOWCHART FOR SUBROUTINE FL

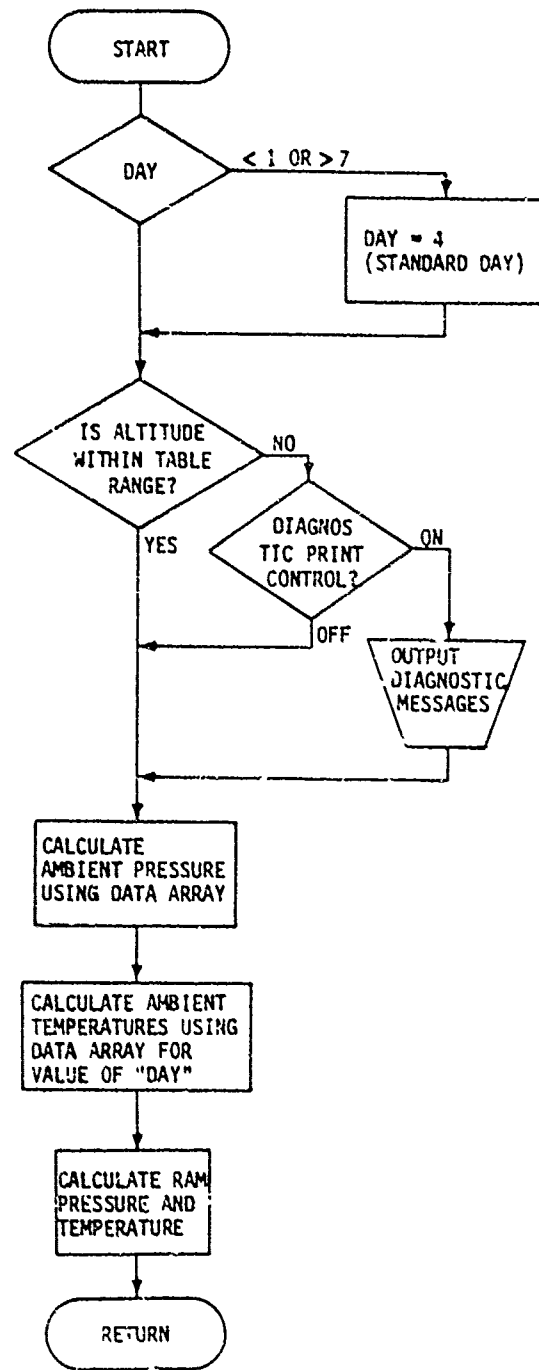
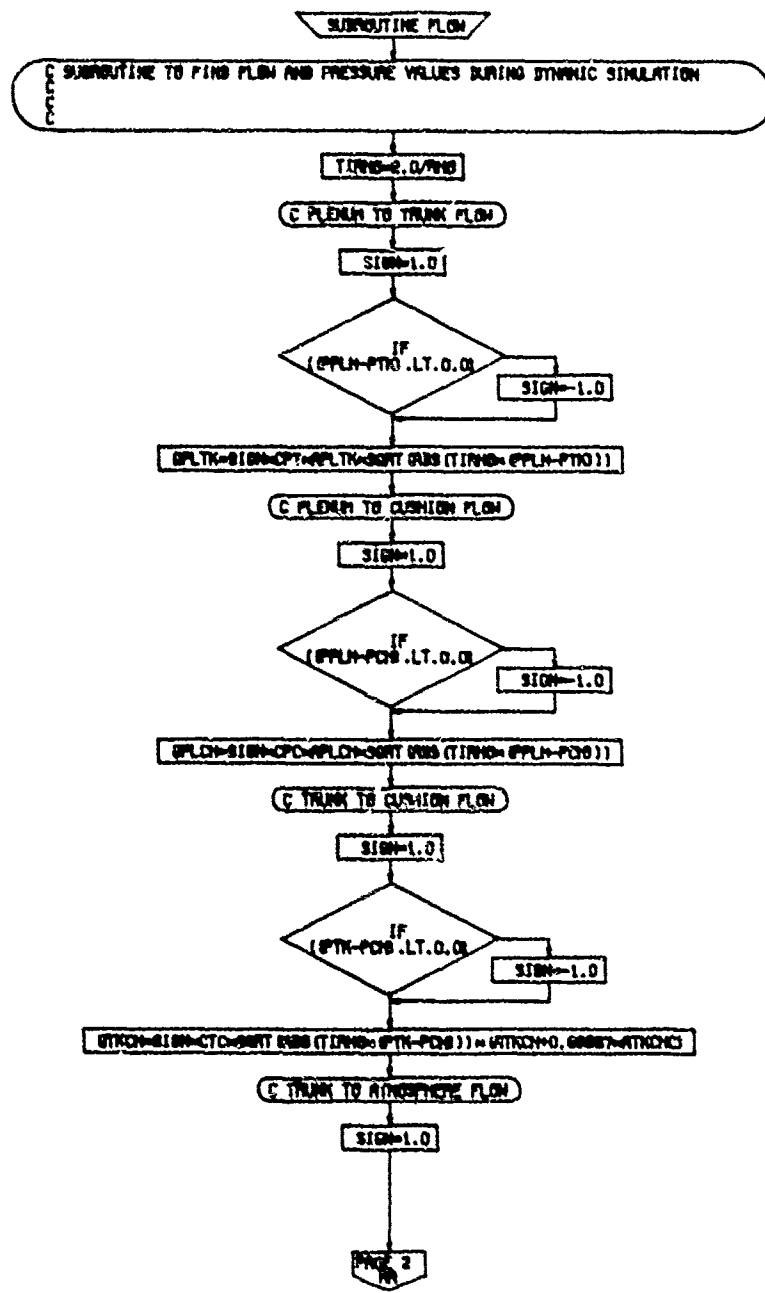
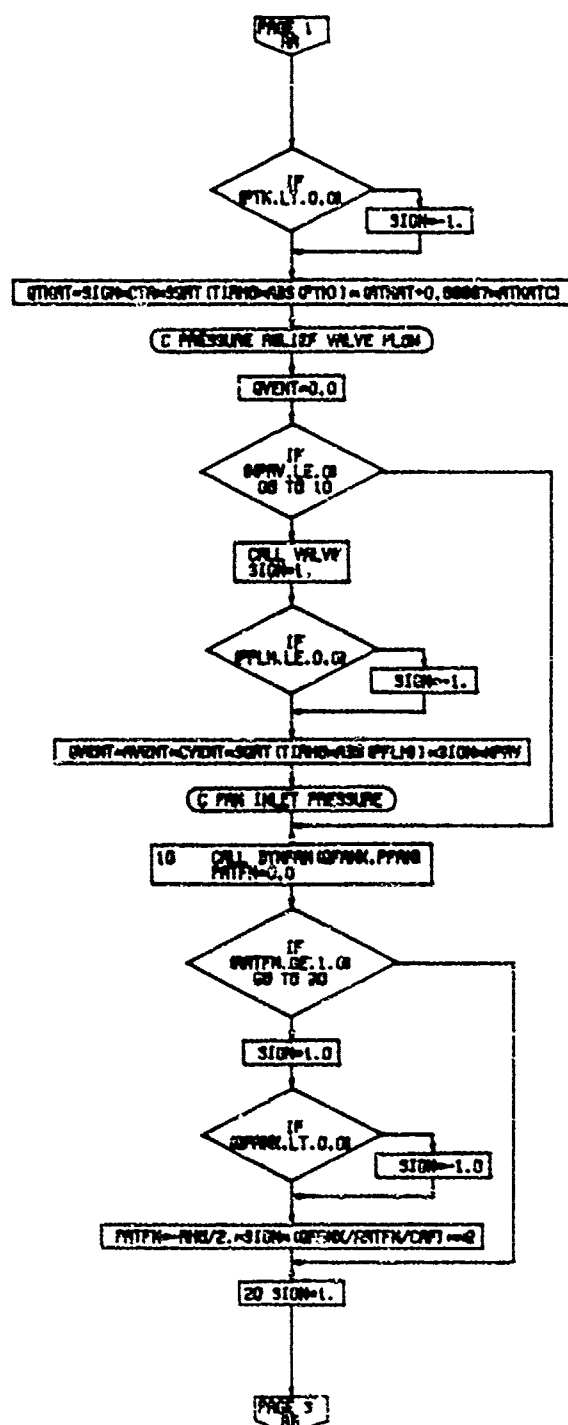

Table 32: FLOWCHART FOR SUBROUTINE FLOW



PAGE 1
FLOW

Table 32: FLOWCHART FOR SUBROUTINE FLOW (CONTINUED)



PAGE 2
FLOW

Table 32: FLOWCHART FOR SUBROUTINE FLOW (CONCLUDED)

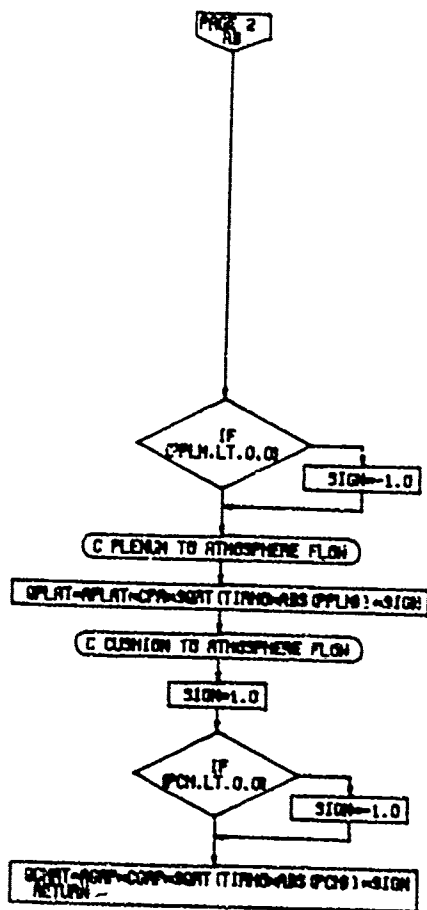

PAGE 3
FLOW

Table 33: FLOWCHART FOR SUBROUTINE FM

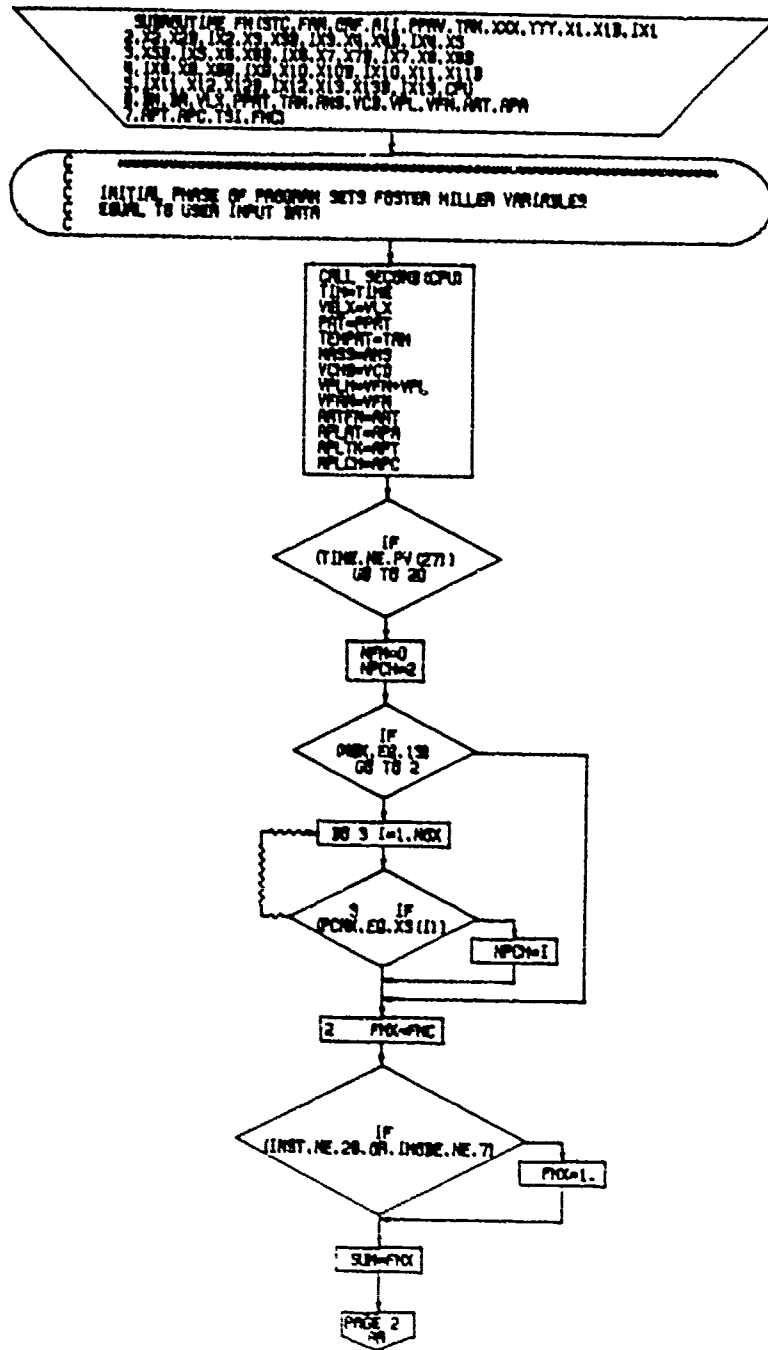

PAGE 1
FM

Table 33: FLOWCHART FOR SUBROUTINE FM (CONTINUED)

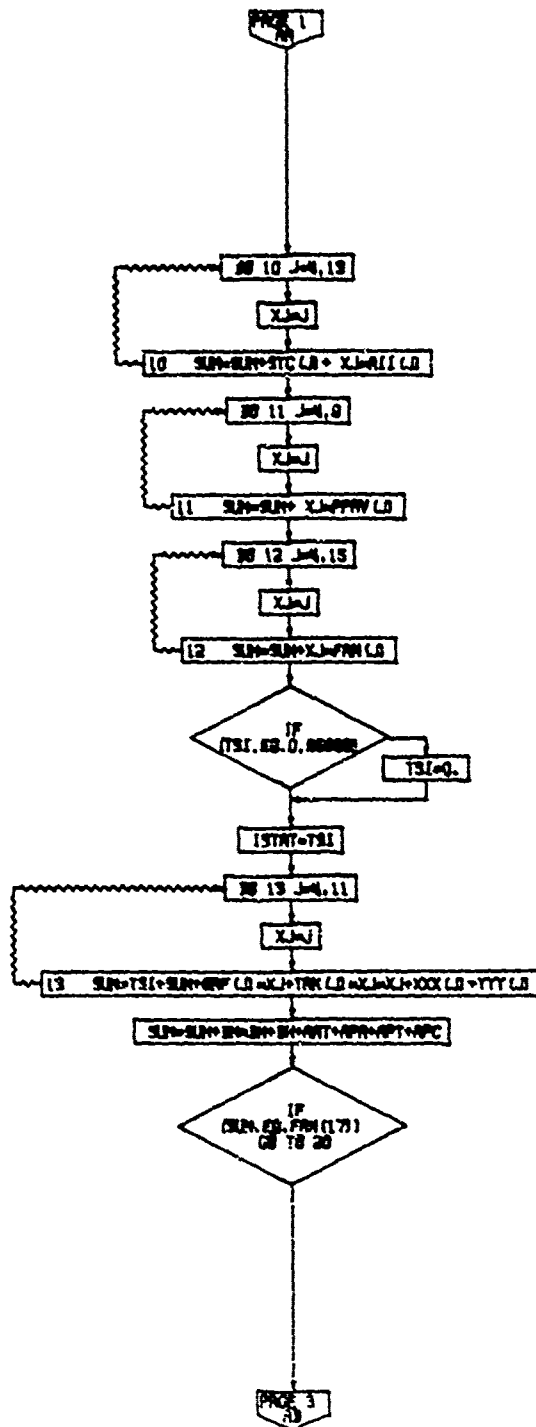

PAGE 2
FM

Table 33: FLOWCHART FOR SUBROUTINE FM (CONTINUED)

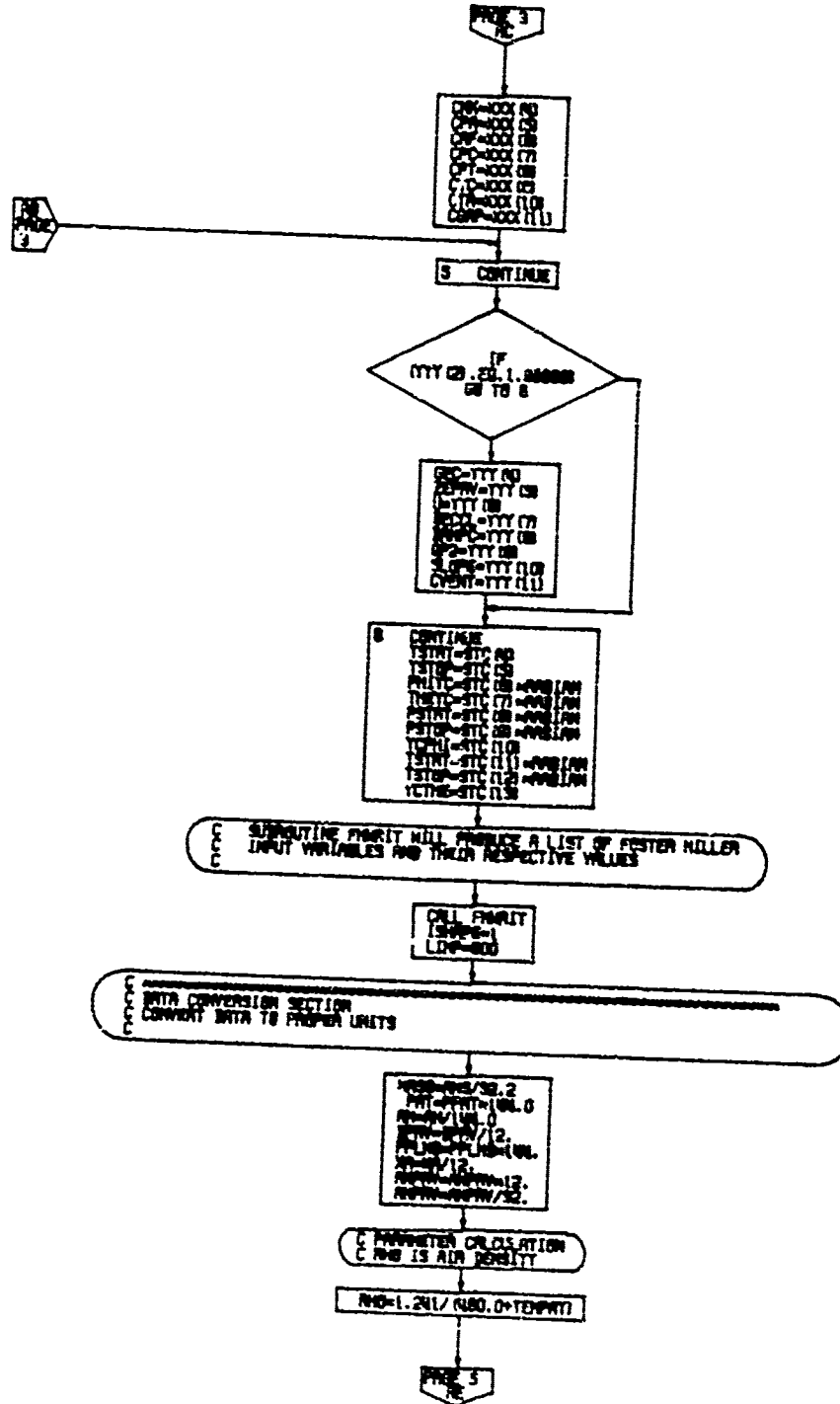

PAGE 4
FM

Table 33: FLOWCHART FOR SUBROUTINE FM (CONTINUED)

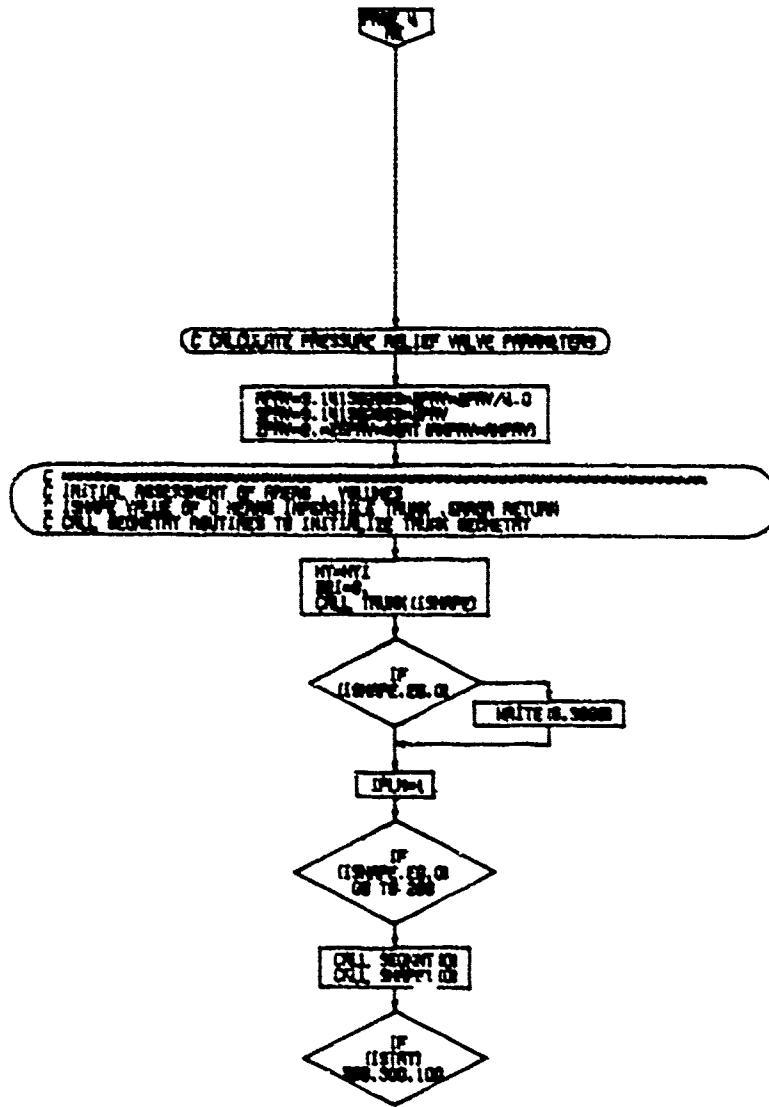
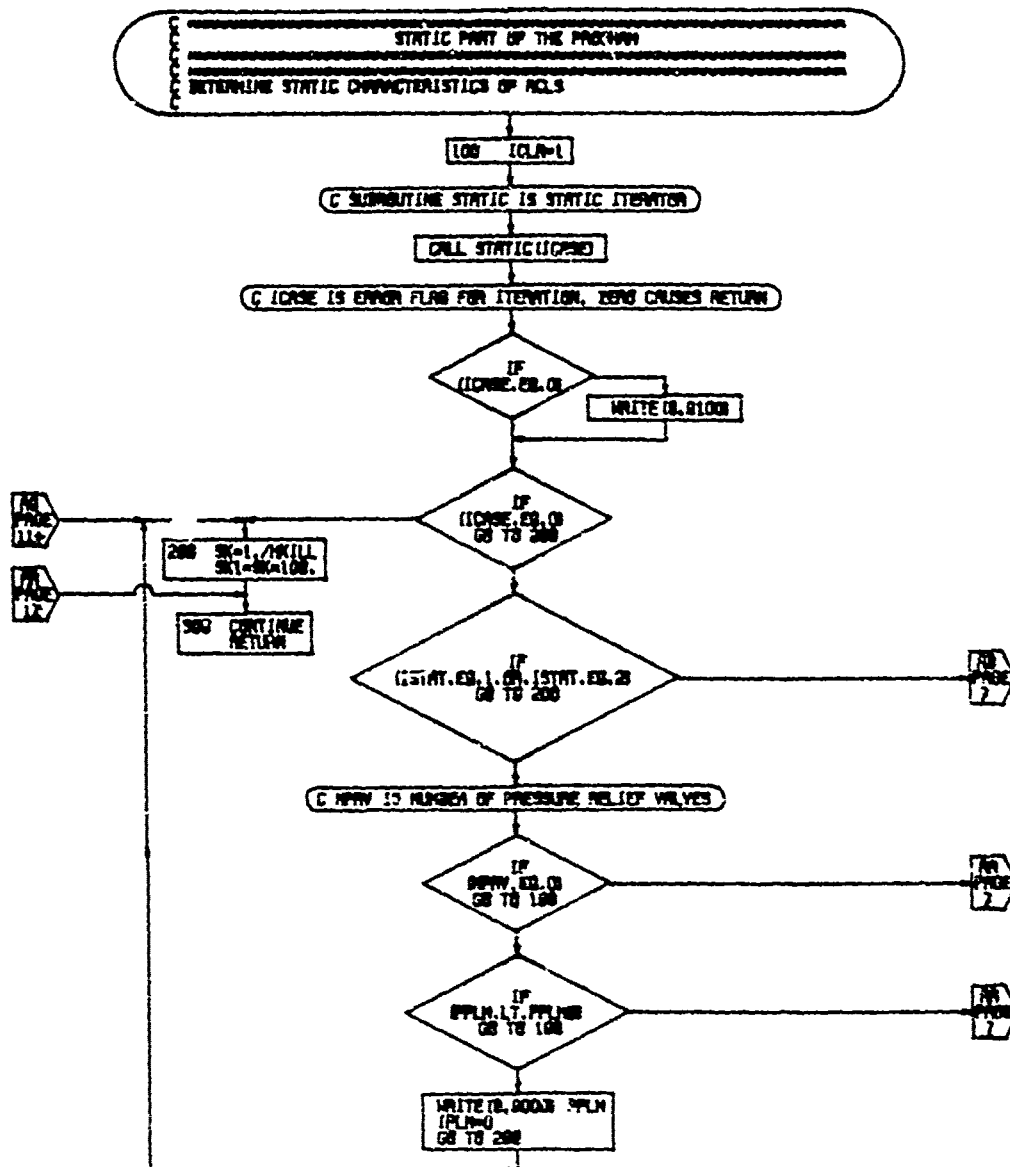
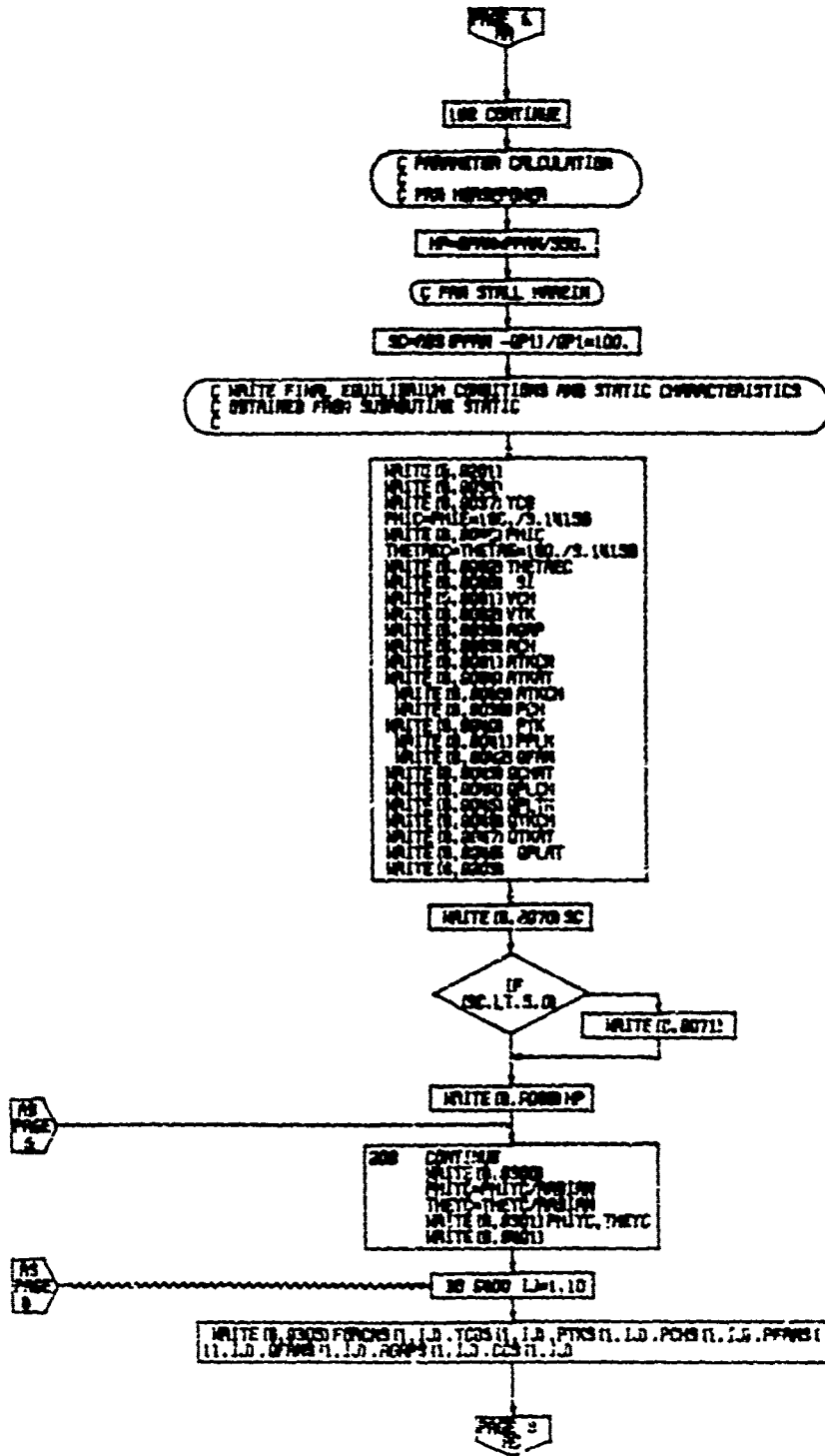

Table 33: FLOWCHART FOR SUBROUTINE FM (CONTINUED)



PAGE 6
FM

Table 33: FLOWCHART FOR SUBROUTINE FM (CONTINUED)



PAGE 7
7X

Table 33: FLOWCHART FOR SUBROUTINE FM (CONTINUED)

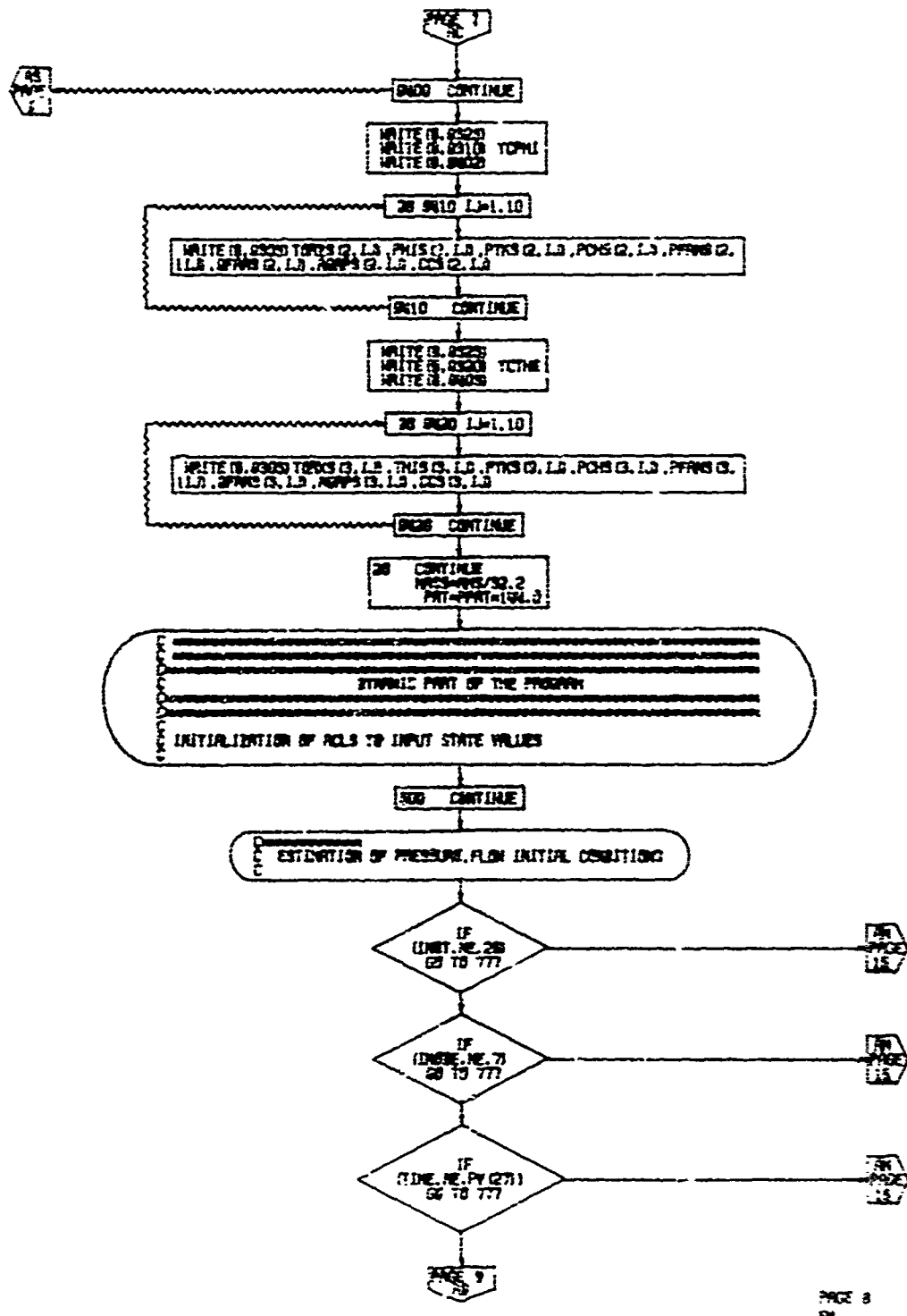
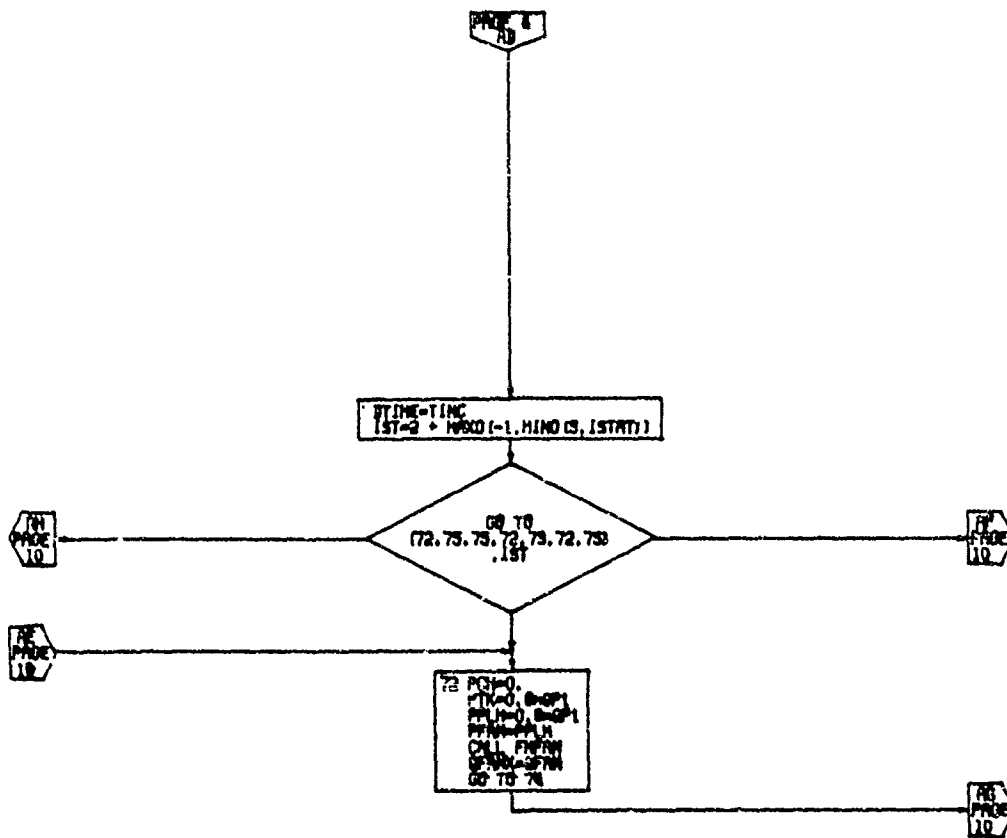
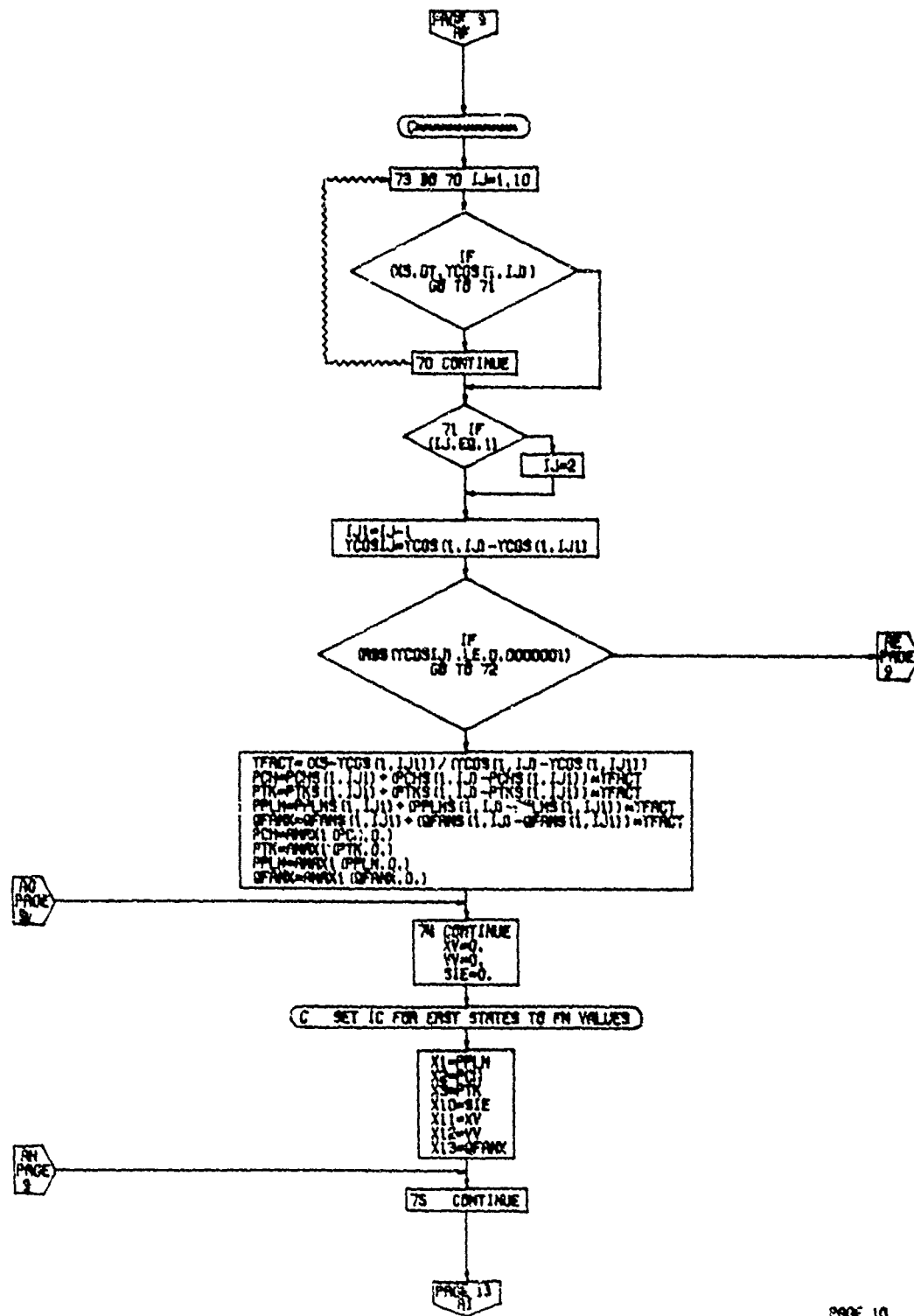

Table 33: FLOWCHART FOR SUBROUTINE FM (CONTINUED)



PAGE 9
FM

Table 33: FLOWCHART FOR SUBROUTINE FM (CONTINUED)



PAGE 10
FM

Table 33: FLOWCHART FOR SUBROUTINE FM (CONTINUED)

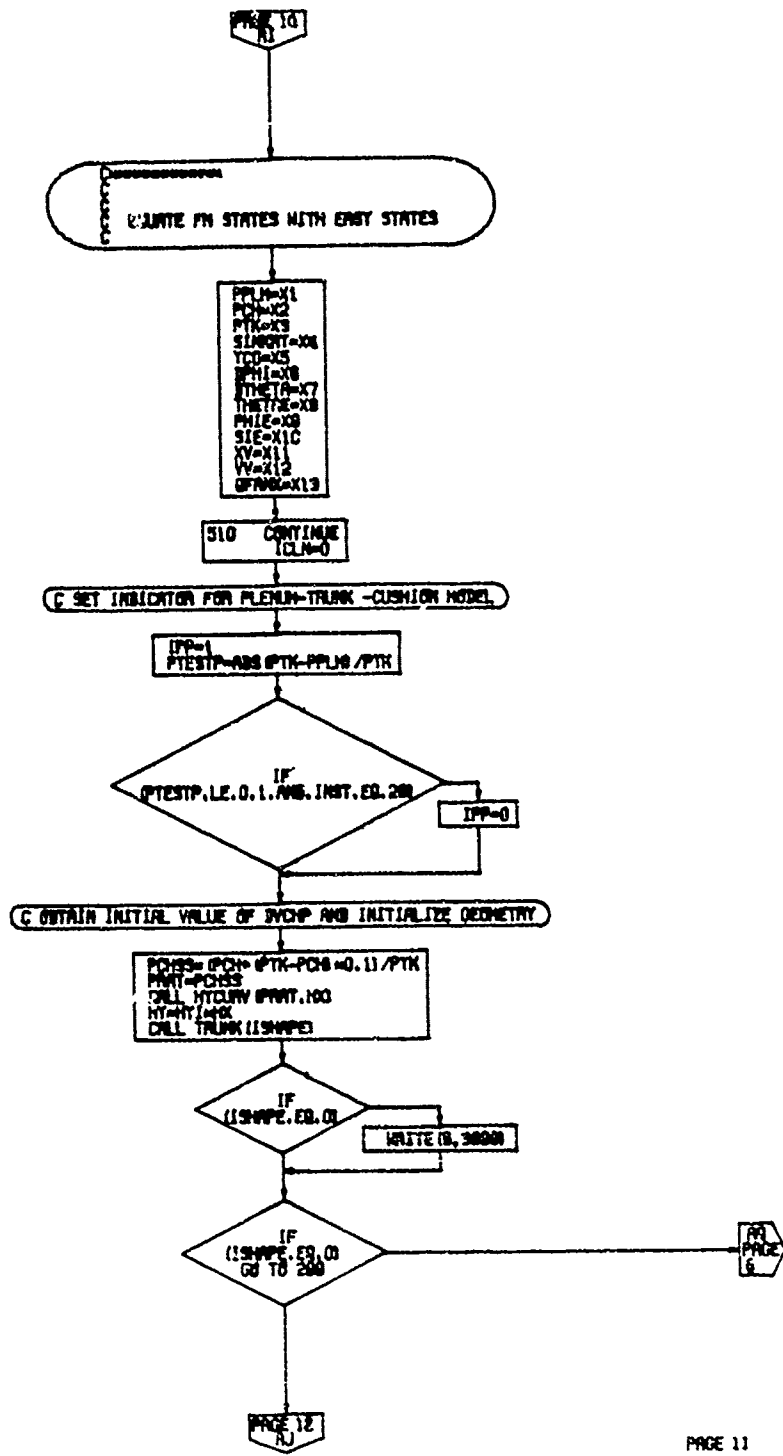

PAGE 11
FM

Table 33: FLOWCHART FOR SUBROUTINE FM (CONTINUED)

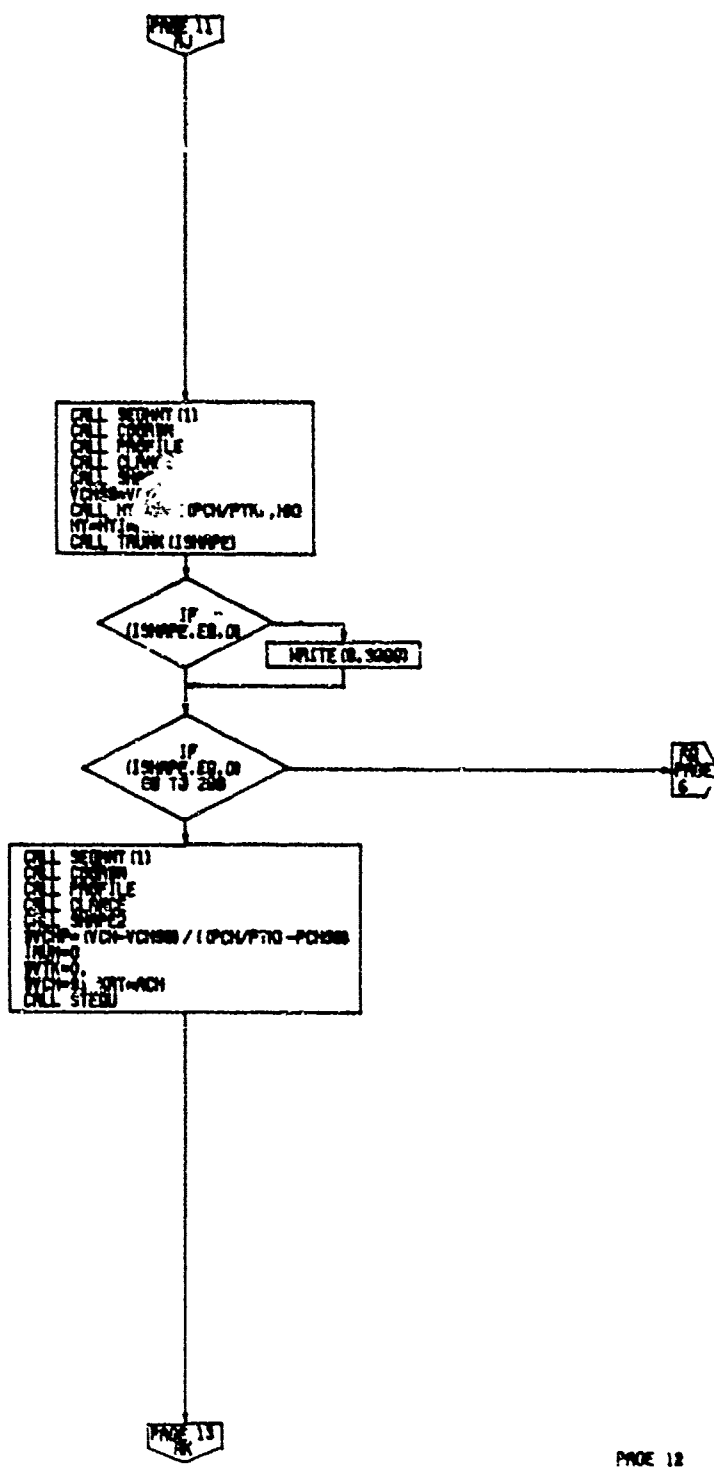

PAGE 12
FK

Table 33: FLOWCHART FOR SUBROUTINE FM (CONTINUED)

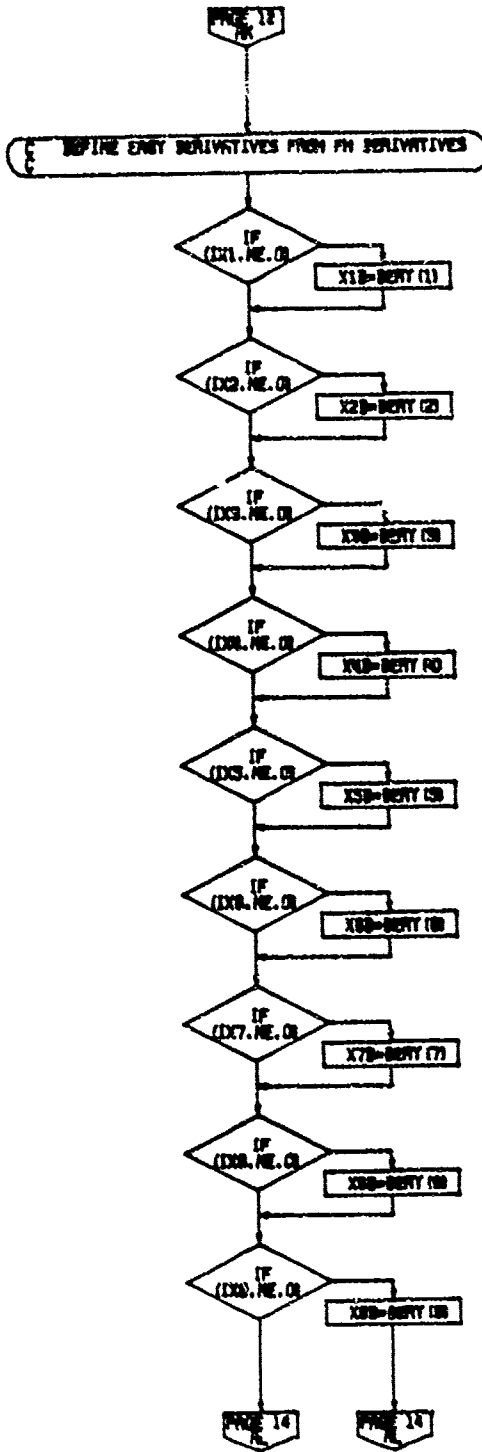

PAGE 13
FM

Table 33: FLOWCHART FOR SUBROUTINE FM (CONTINUED)

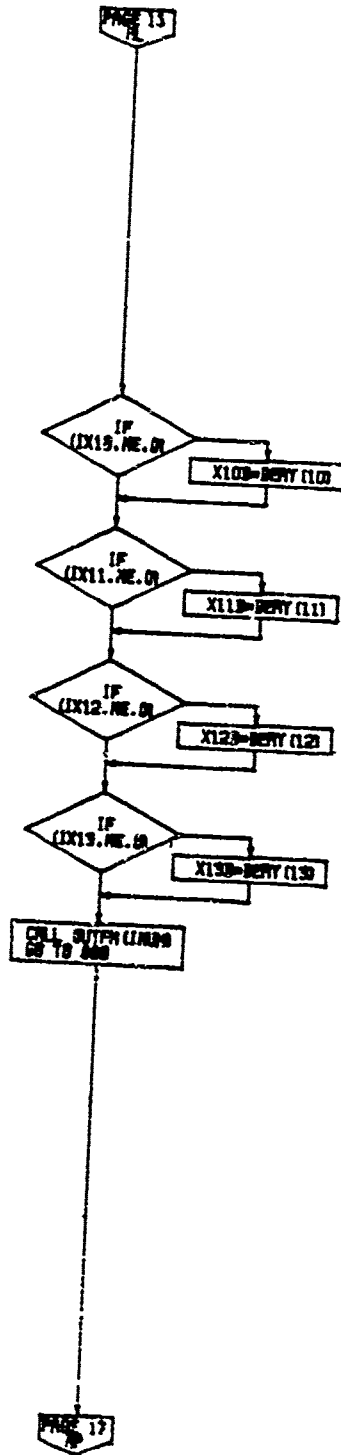

PAGE 14
FM

Table 33: FLOWCHART FOR SUBROUTINE FM (CONTINUED)

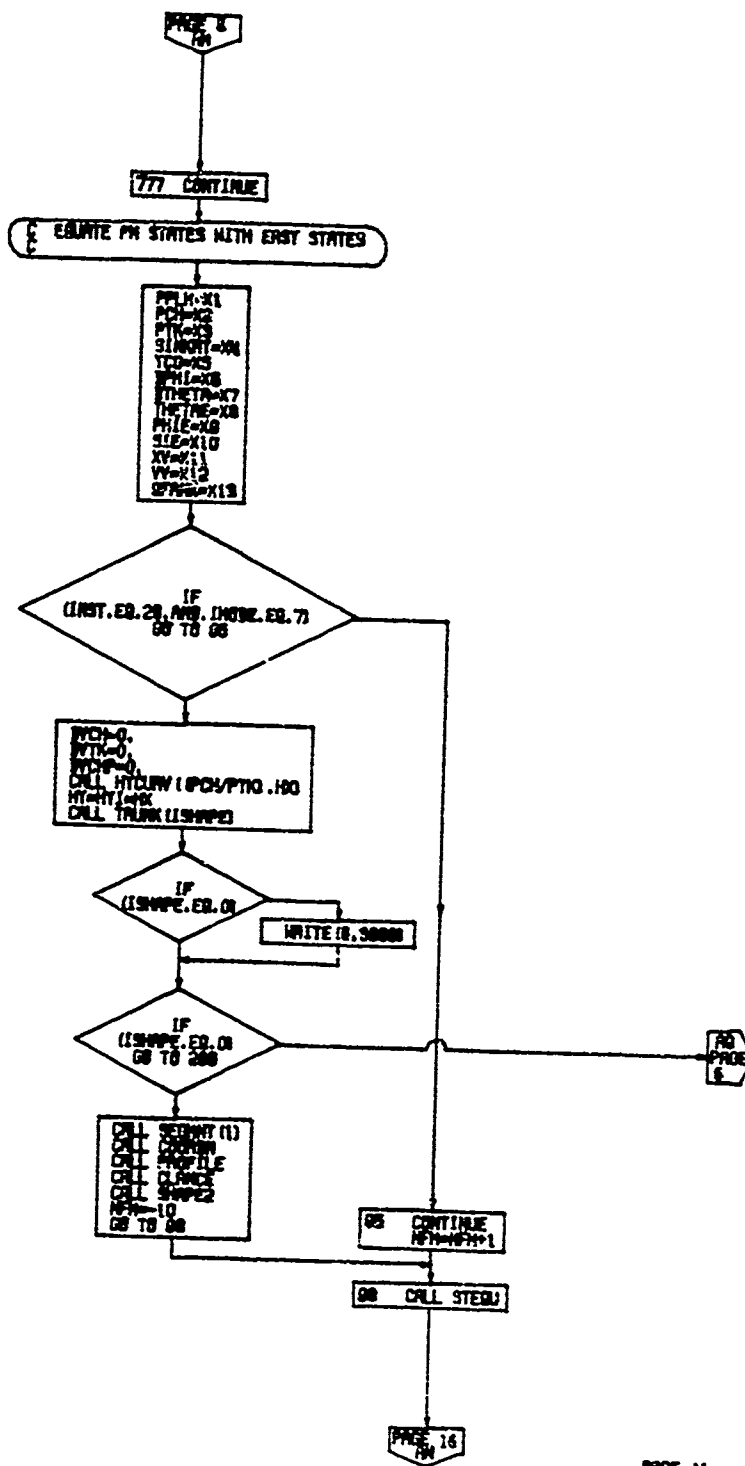

PAGE 11
FM

Table 33: FLOWCHART FOR SUBROUTINE FM (CONTINUED)

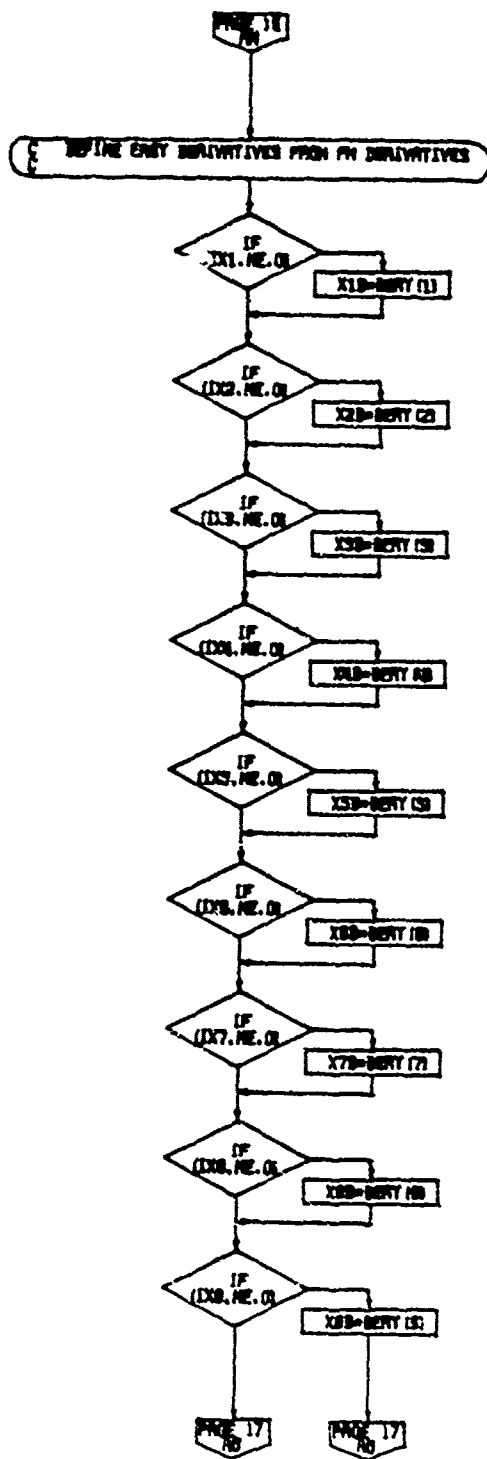

PAGE 16
FM

Table 33: FLOWCHART FOR SUBROUTINE FM (CONCLUDED)

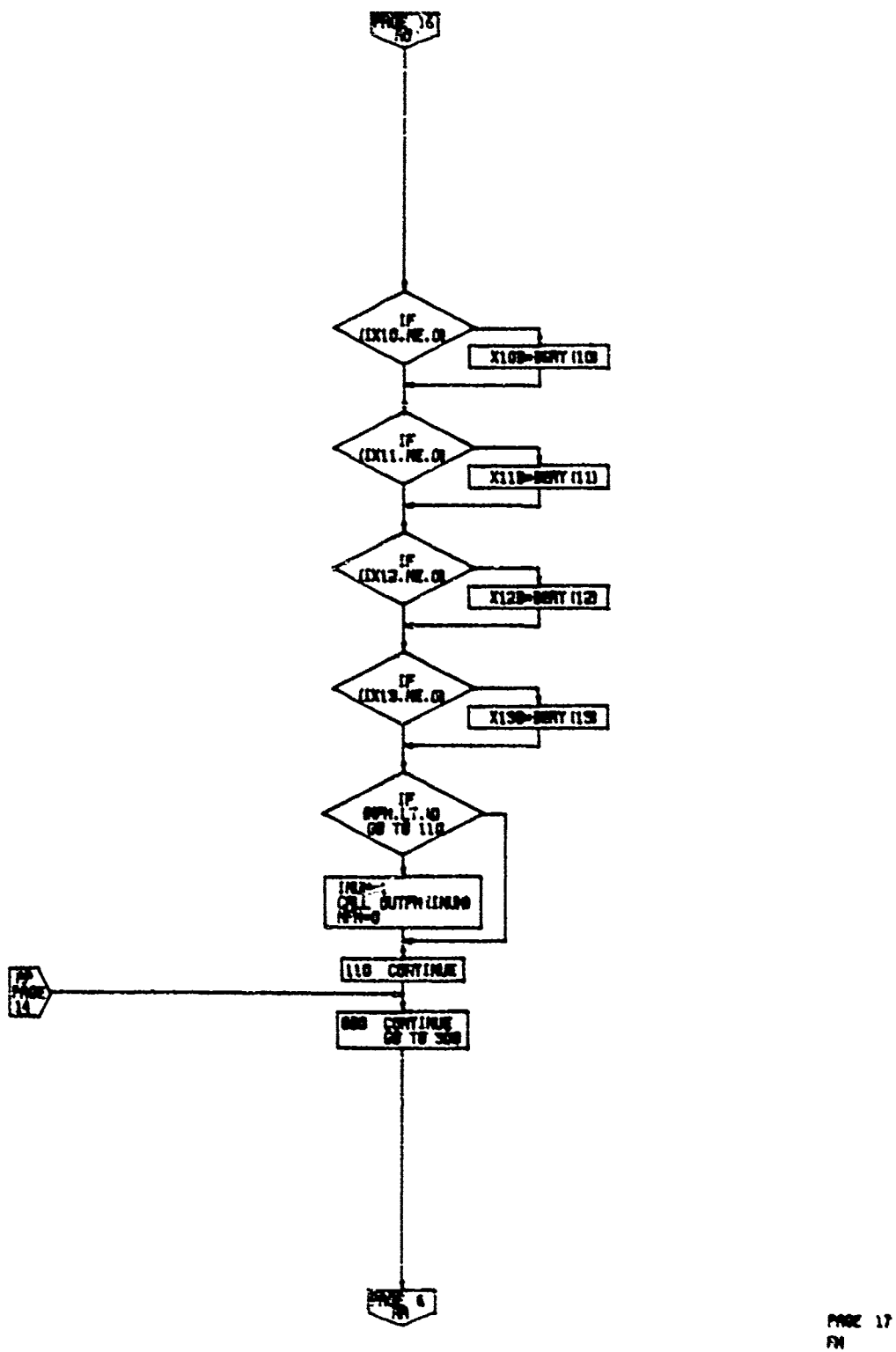

Table 34: FLOWCHART FOR SUBROUTINE FMFAN

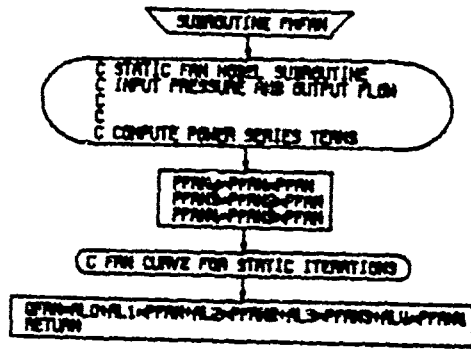

Table 35: FLOWCHART FOR SUBROUTINE FMWRIT

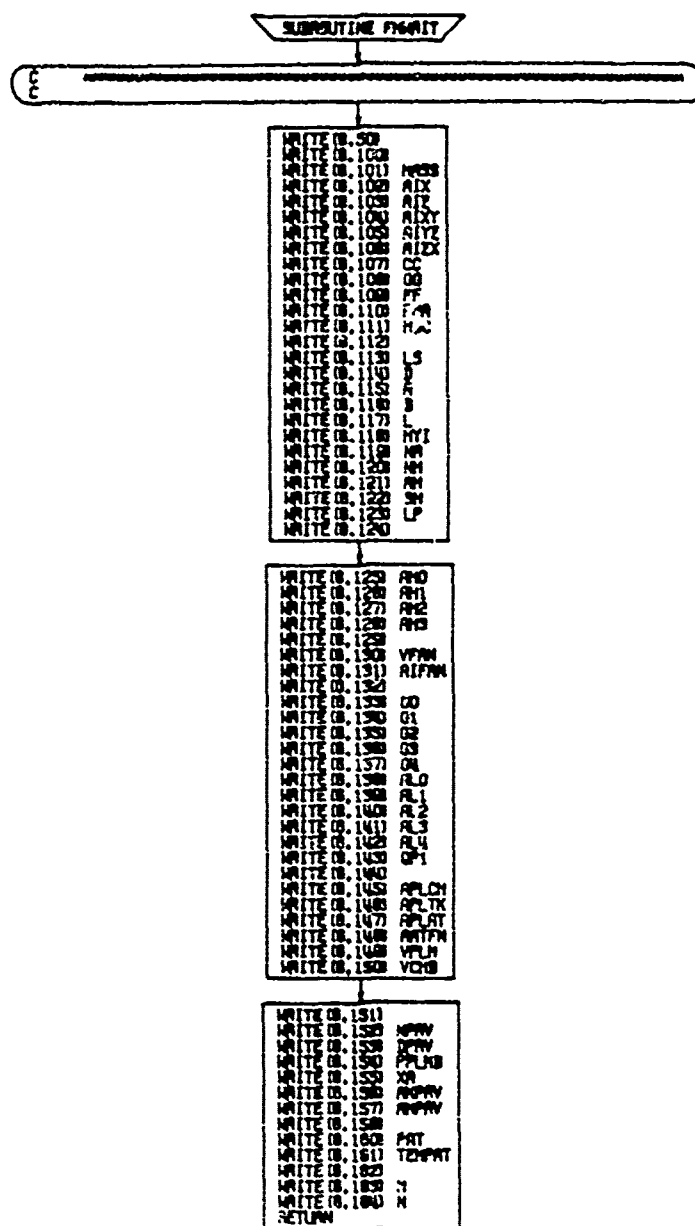
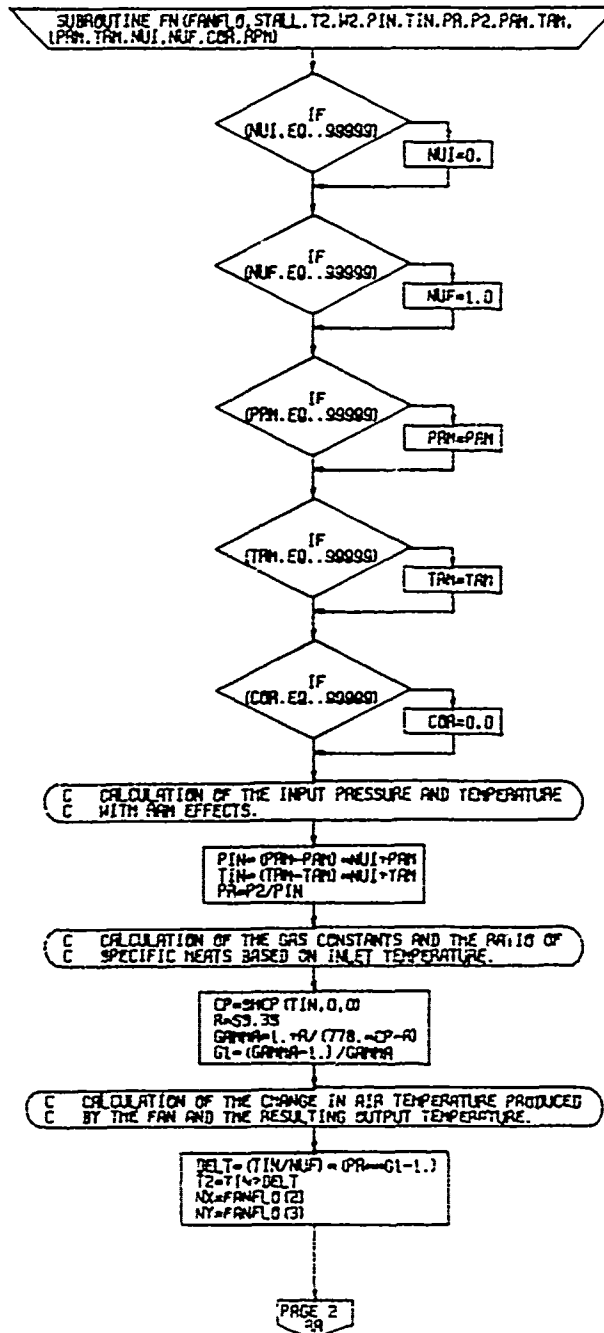

Table 36: FLOWCHART FOR SUBROUTINE FN



PAGE :
FN

Table 36: FLOWCHART FOR SUBROUTINE FN (CONCLUDED)

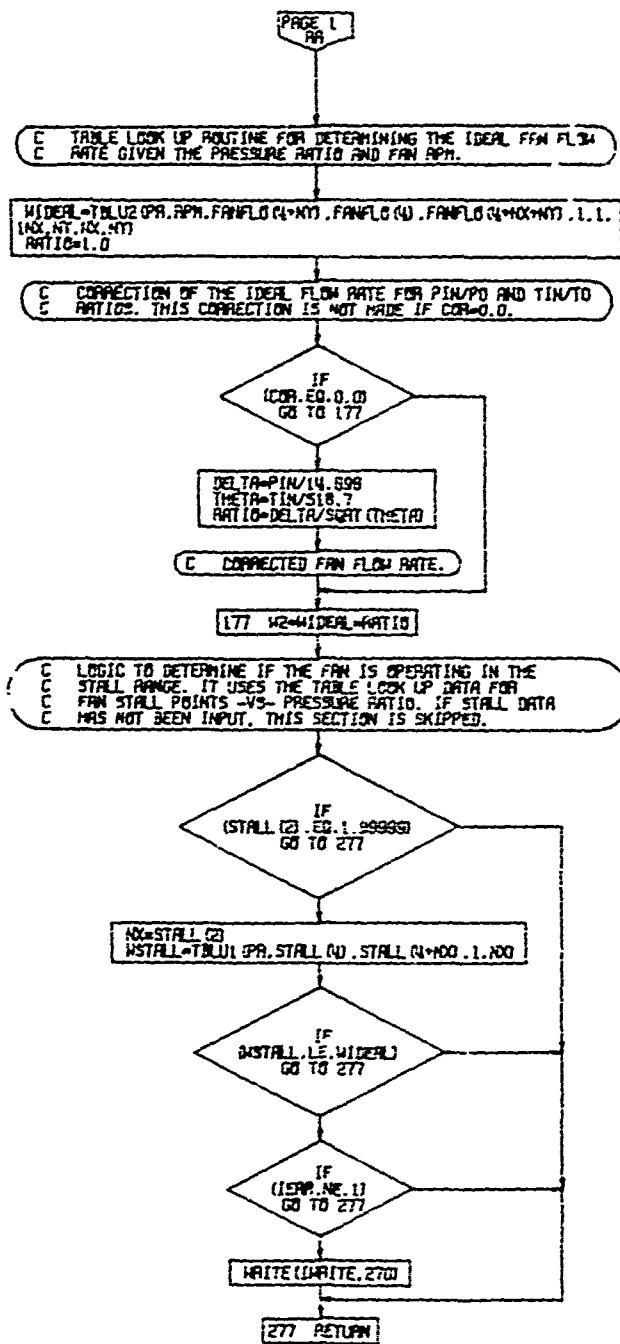

Table 37: FLOWCHART FOR SUBROUTINE FNFLOW

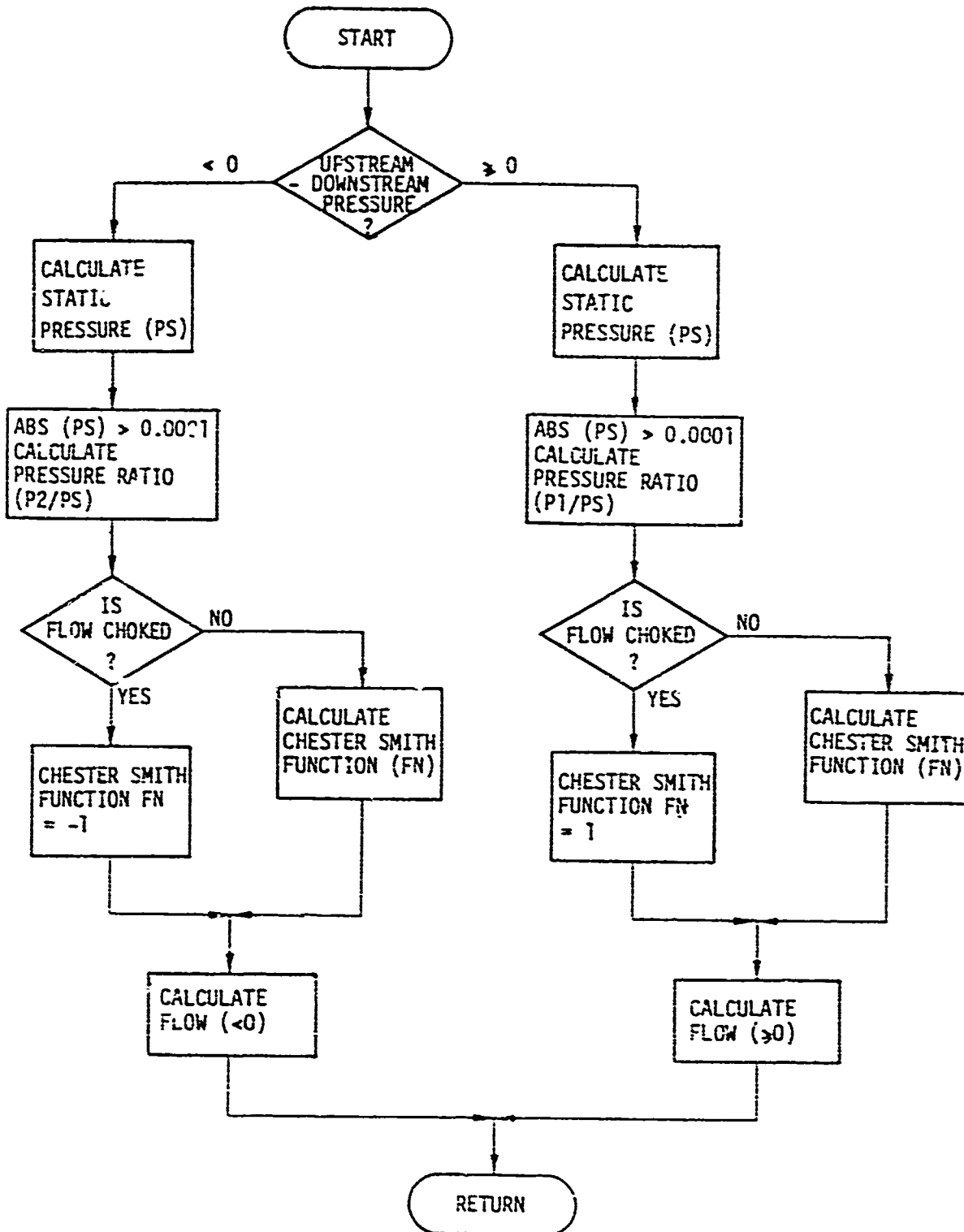
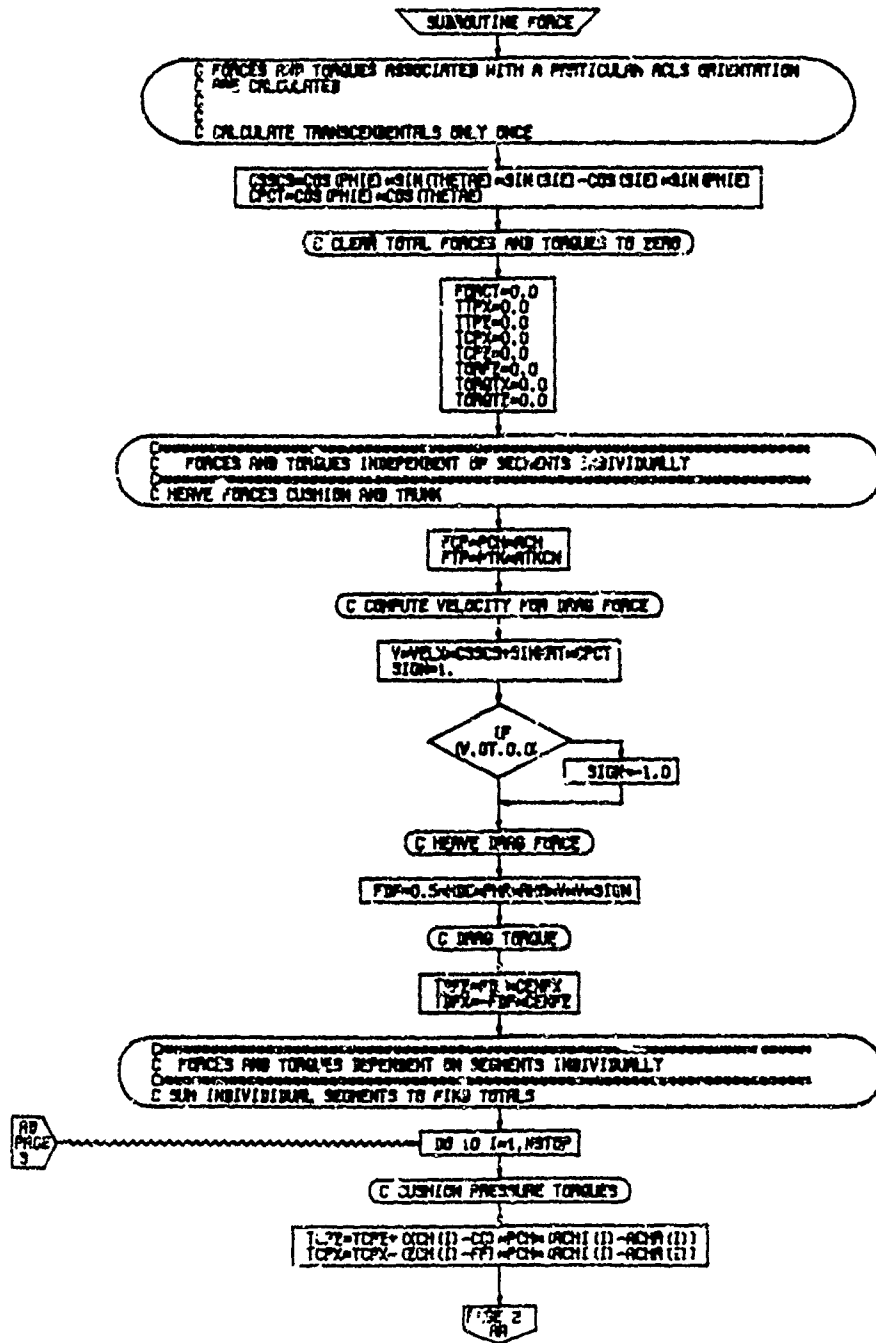
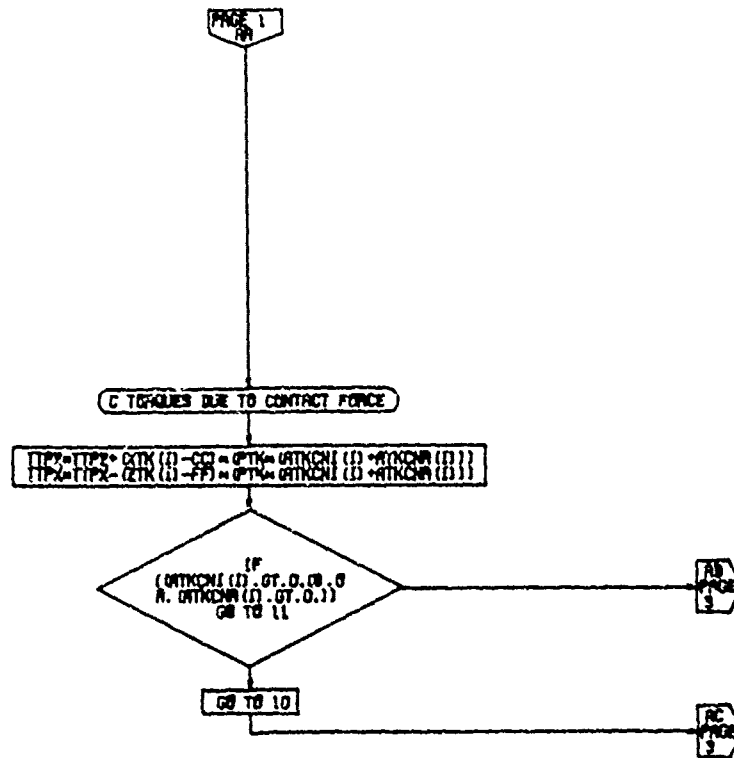

Table 38: FLOWCHART FOR SUBROUTINE FORCE



PAGE 1
FORCE

Table 38: FLOWCHART FOR SUBROUTINE FORCE (CONTINUED)



PAGE 2
FORCE

Table 38: FLOWCHART FOR SUBROUTINE FORCE (CONCLUDED)

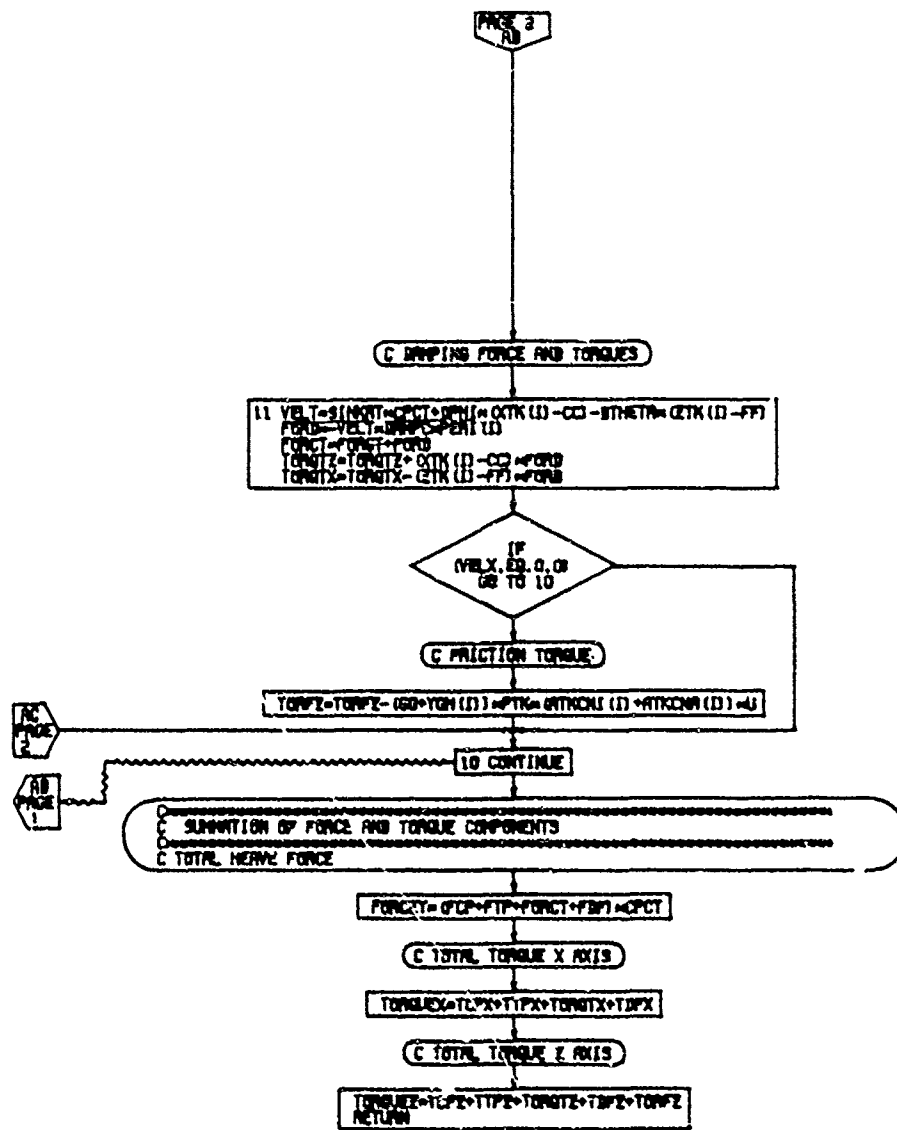

PAGE 5
FORCE

Table 39: FLOWCHART FOR SUBROUTINE FR

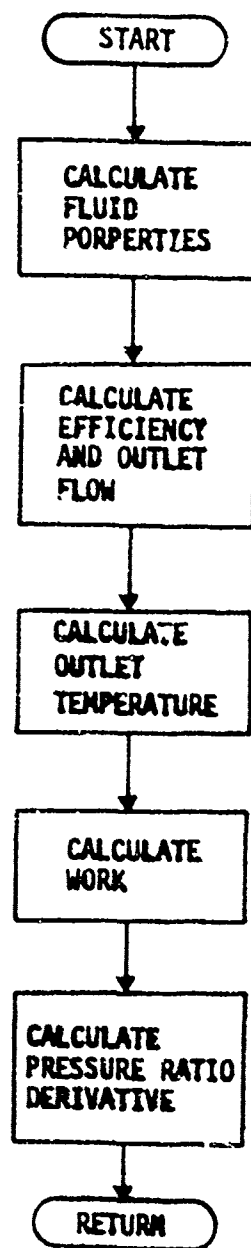

Table 40: FLOWCHART FOR SUBROUTINE FS

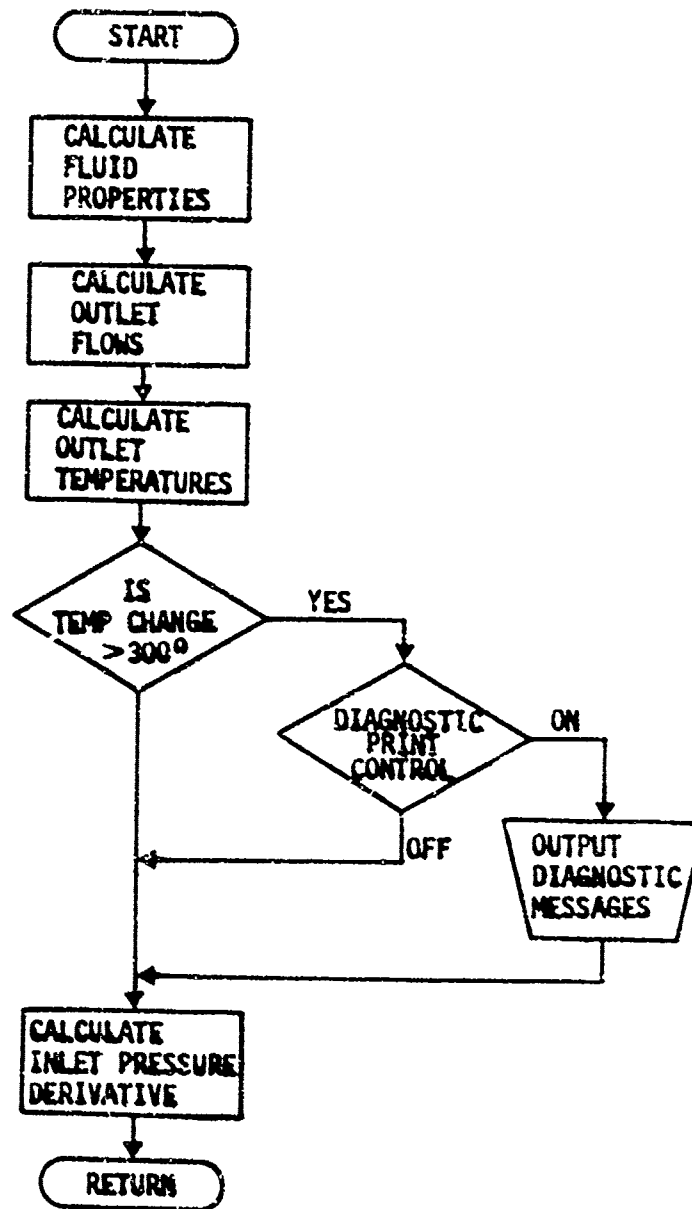

Table 41: FLOWCHART FOR SUBROUTINE FSFLOW

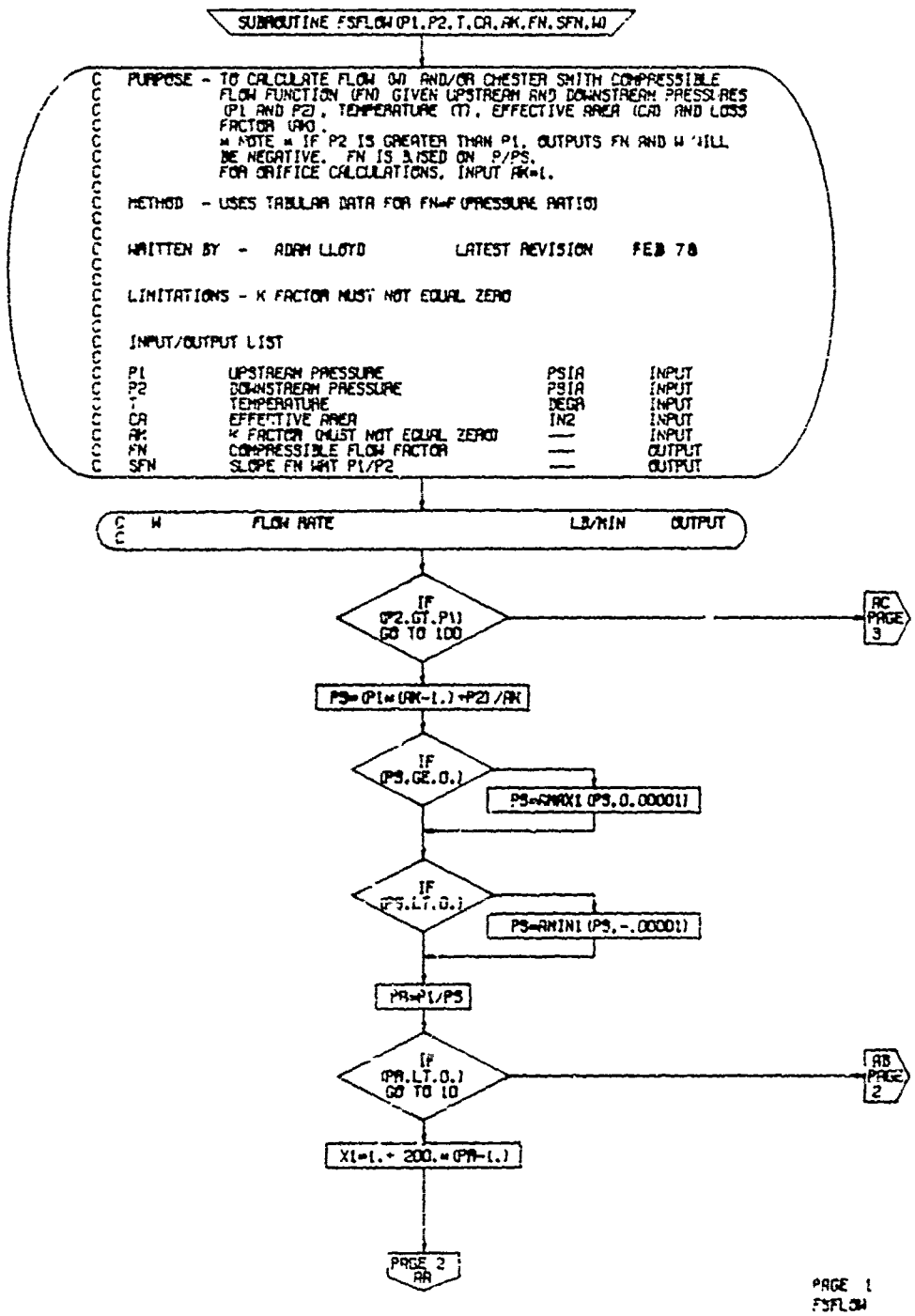
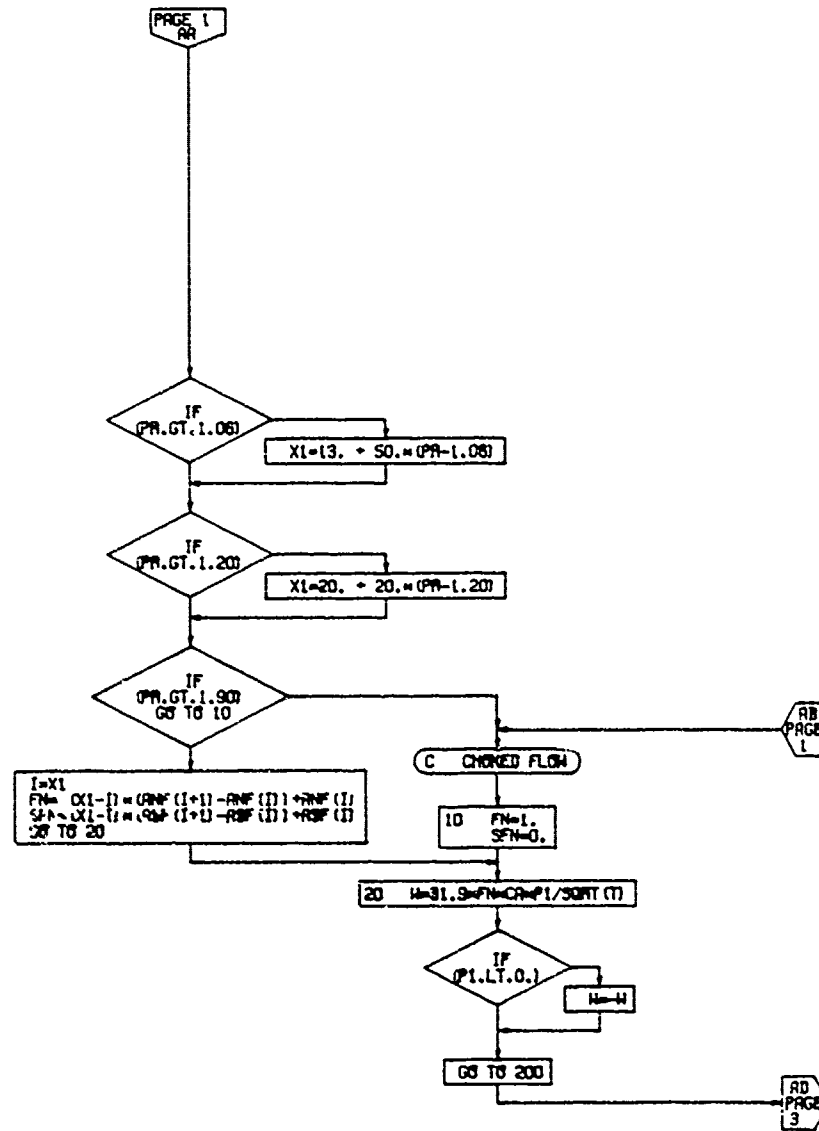
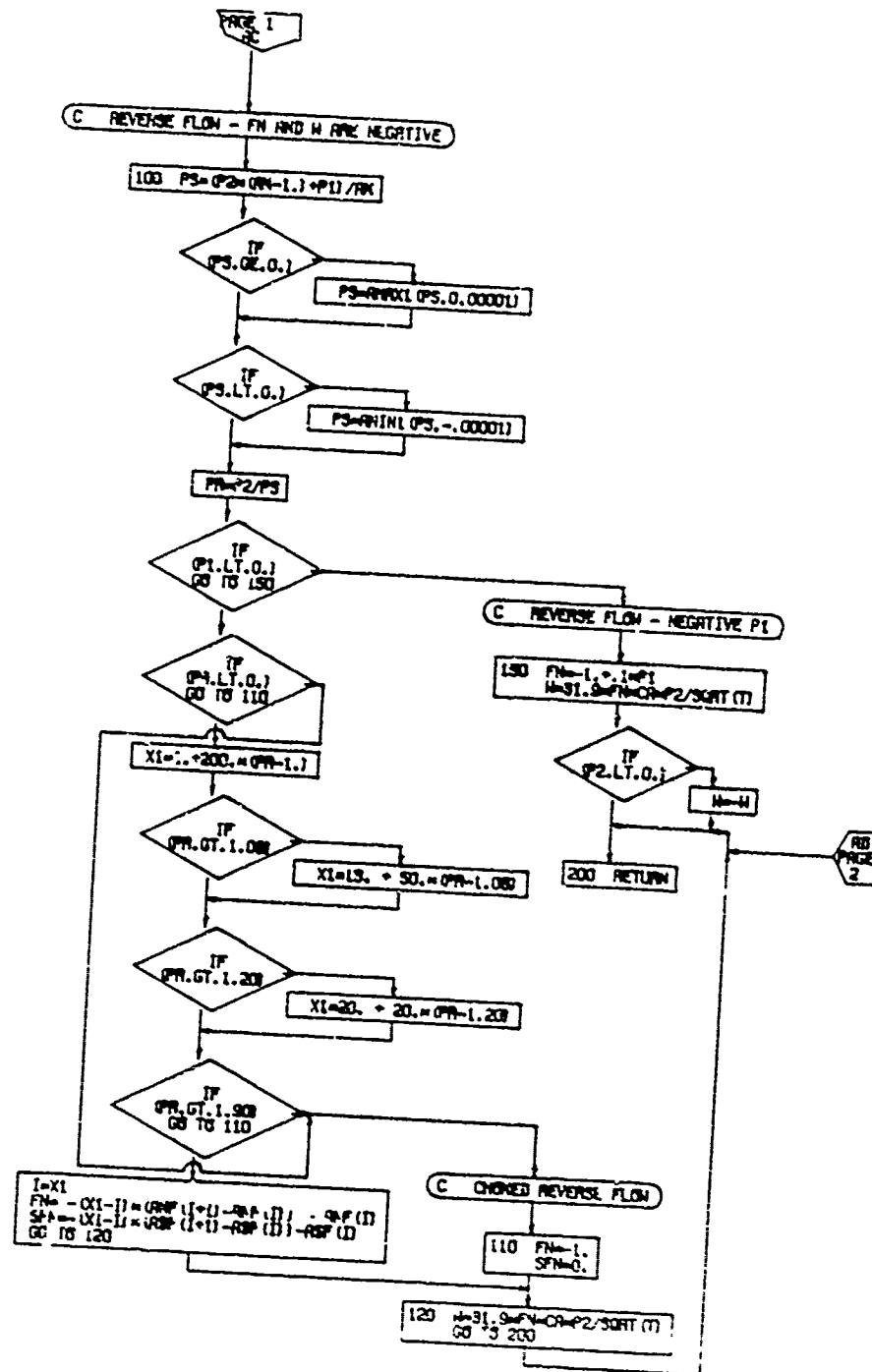

Table 41: FLOWCHART FOR SUBROUTINE FSFLOW (CONTINUED)



PAGE 2
FSFL34

Table 41: FLOWCHART FOR SUBROUTINE FSFLOW (CONCLUDED)



PAGE 3
FSFLOW

Table 42: FLOWCHART FOR SUBROUTINE FT

SUBROUTINE FT (WC, TOT, T3, W3, P1, P1DOT, IP1, T1, W1, T2, P2, P3, VOL, FC)

VERSION 2. SEPT 18 1977

PURPOSE SIMULATE A HUB OR TIP DRIVEN AXIAL TURBO FAN AS USED ON THE JINDIVIK ACLS VEHICLE

METHOD - USES INPUT TABLES DEFINING STEADY STATE CHARACTERISTICS OF TURBINE AND FAN. DRIVE/BLEED AIR TURBINE INLET PRESSURE IS A STATE.

CALL SEQUENCE

*****	TABLE	*****
WC	-TABLE OF CORRECTED TURBINE FLOW AS A FUNCTION OF DRIVE (BLEED AIR) TO CUSHION/TRUNK PRESSURE RATIO.	-ONE DIMENSIONAL TABLE
TOT	-TABLE OF TOTAL FLOW FROM TURBOFAN AS A FUNCTION OF CUSHION/TRUNK PRESSURE (PSFG) AND DRIVE PRESSURE (PSIA)	-TWO DIMENSIONAL TABLE
*****	OUTPUTS	*****
T3	-TEMPERATURE OF FAN AIR EXIT, DEG RANKINE	
W3	-TOTAL FLOW FROM TURBOFAN TO CUSHION/TRUNK, LB/MIN (PORT NO 2)	
P1	-DRIVE/BLEED AIR PRESSURE, PSIA (PORT NO 1)	
P1DOT	-DERIVATIVE OF P1, PSIA/SEC	
IP1	-INTEGRATOR CONTROL FOR P1	
*****	INPUTS	*****
T1	-DRIVE/BLEED AIR TEMPERATURE, DEG RANKINE	
W1	-DRIVE/BLEED AIR FLOW RATE, LB/MIN (PORT NO 1)	

T2 - AMBIENT AIR TEMPERATURE, DEG RANKINE
P2 - AMBIENT AIR PRESSURE, PSIA (PORT NO 2)
P3 - PRESSURE OF FAN AIR EXIT, PSIG (PORT NO 3)
VOL - INTERNAL VOLUME, CU. FT.
FC - FREQUENCY CONTROL ON P1 (FC.GE.1.)
-A VALUE OF FC GREATER THAN 1. DECREASES
-FREQUENCY RESPONSE OF P1 CORRESPONDINGLY

WRITTEN BY MAHINDER WAHI JUNE 1977

C CALCULATE TURBINE FLOW RATE FROM INPUT TABLE

PAAT = P1/P3
PAAT = AMAX(1., PAAT)
NOC = WC(2)
WCOB = TBLU1 (PAAT, WC (NOC), WC (NOC+4), 1., -NOC)
W1CAL = 60*WCOB*1.55*P1/SQRT (T1)

IF (IP1.NE.0)

P1DOT = PAAT*W1 (W1 - W1CAL) / (8640.*FC*VOL)

C CALCULATE FAN PERFORMANCE FROM INPUT TABLES

PSF = (P3 - P2) * 144.
N1 = TOT (3) * 4
N2 = T1 (2) * TOT (3) * 4
N3 = T1 (2)
N4 = TOT (3)
W3 = 60 * TBLU2 (PSF, P1, TOT (N1), TOT (N2), TOT (N3), 1., 1., -N3, -N4, N3, N4)
W3 = AMAX(1, W3)
W2 = W3 - W1CAL
T3 = 8 * (W1 + W2 + T2) / W3
T3 = AMAX(1, T3)
RETURN

Table 43: FLOWCHART FOR SUBROUTINE FU

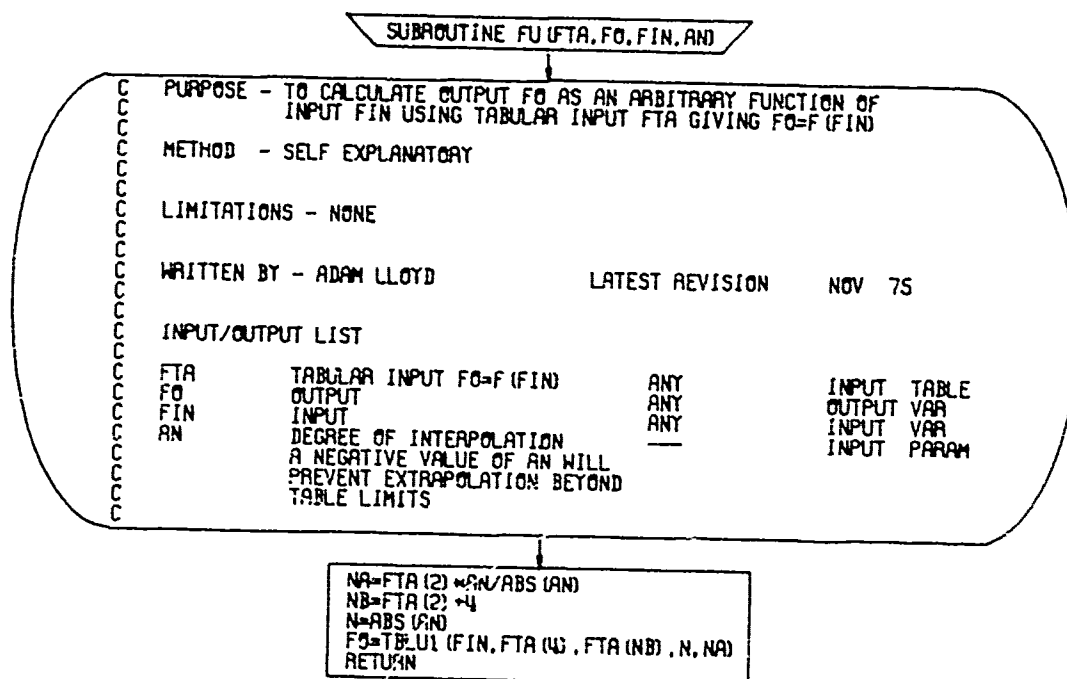

Table 44: FLOWCHART FOR SUBROUTINE FV

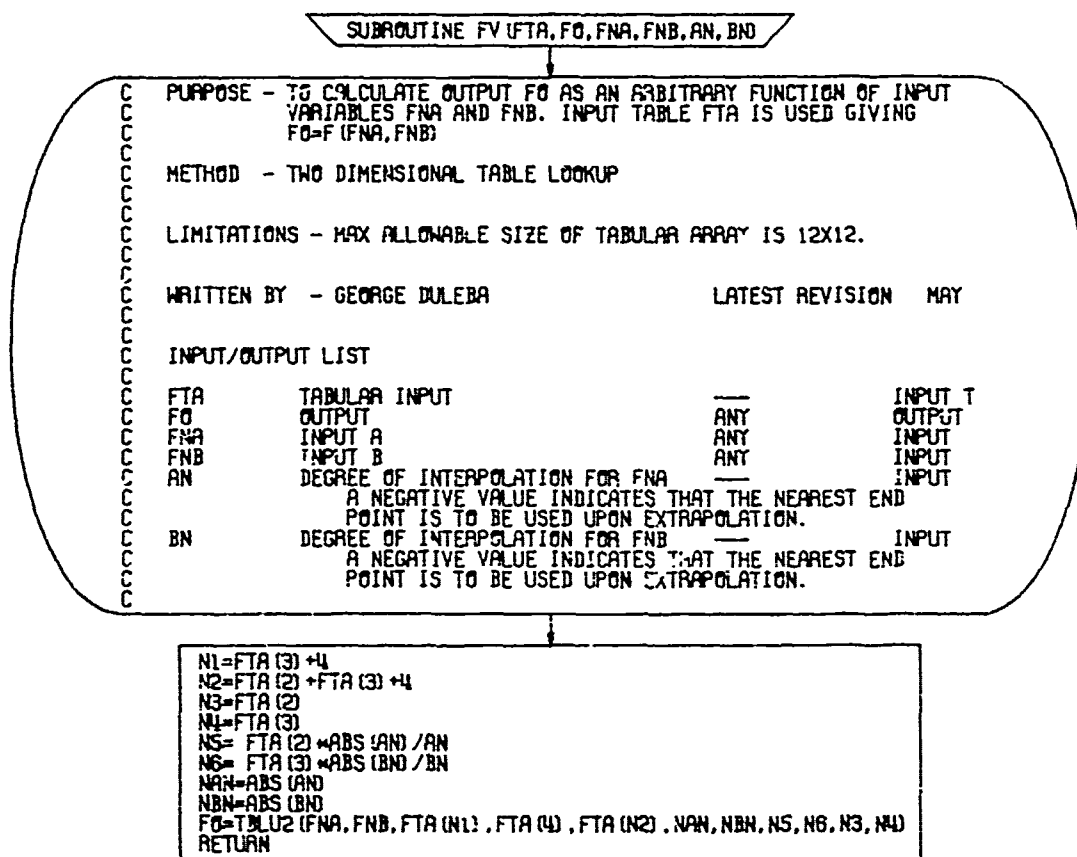

Table 45: FLOWCHART FOR SUBROUTINE GW

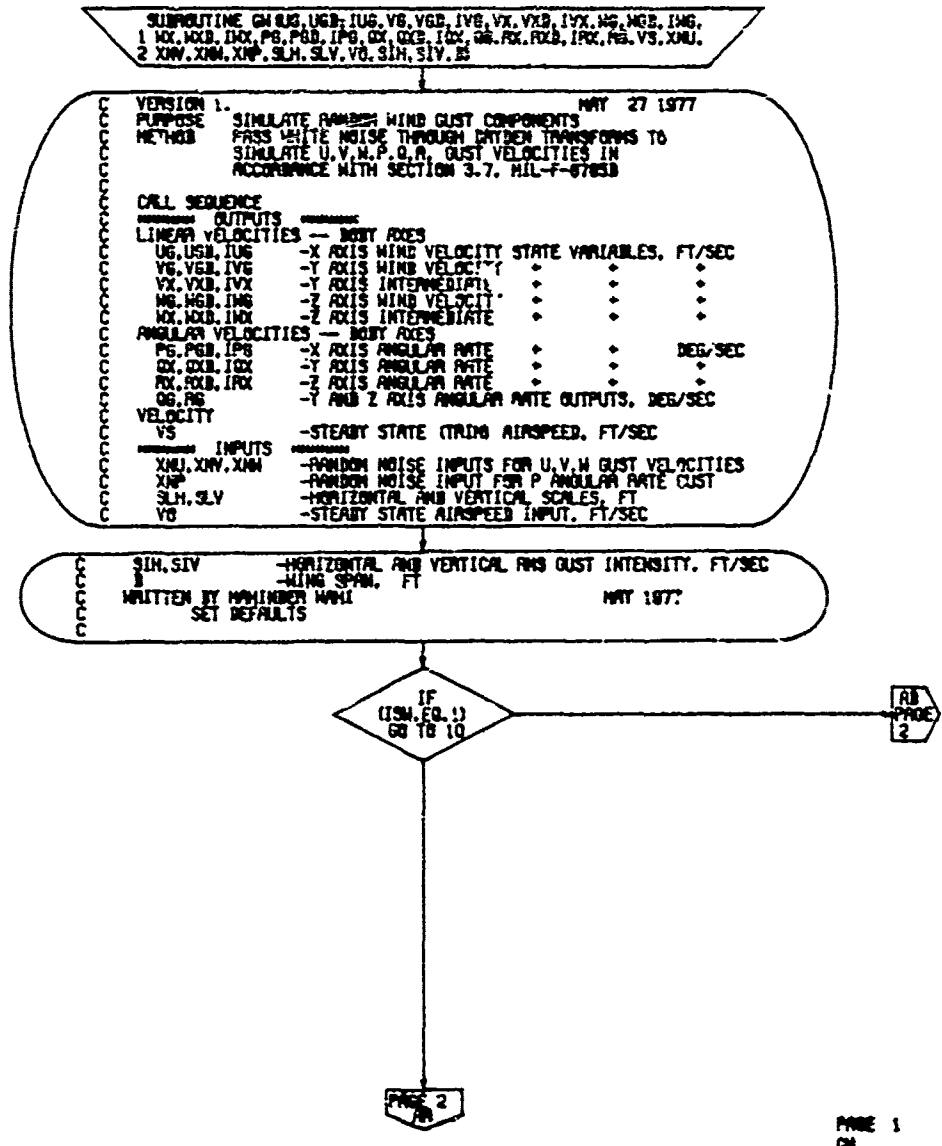
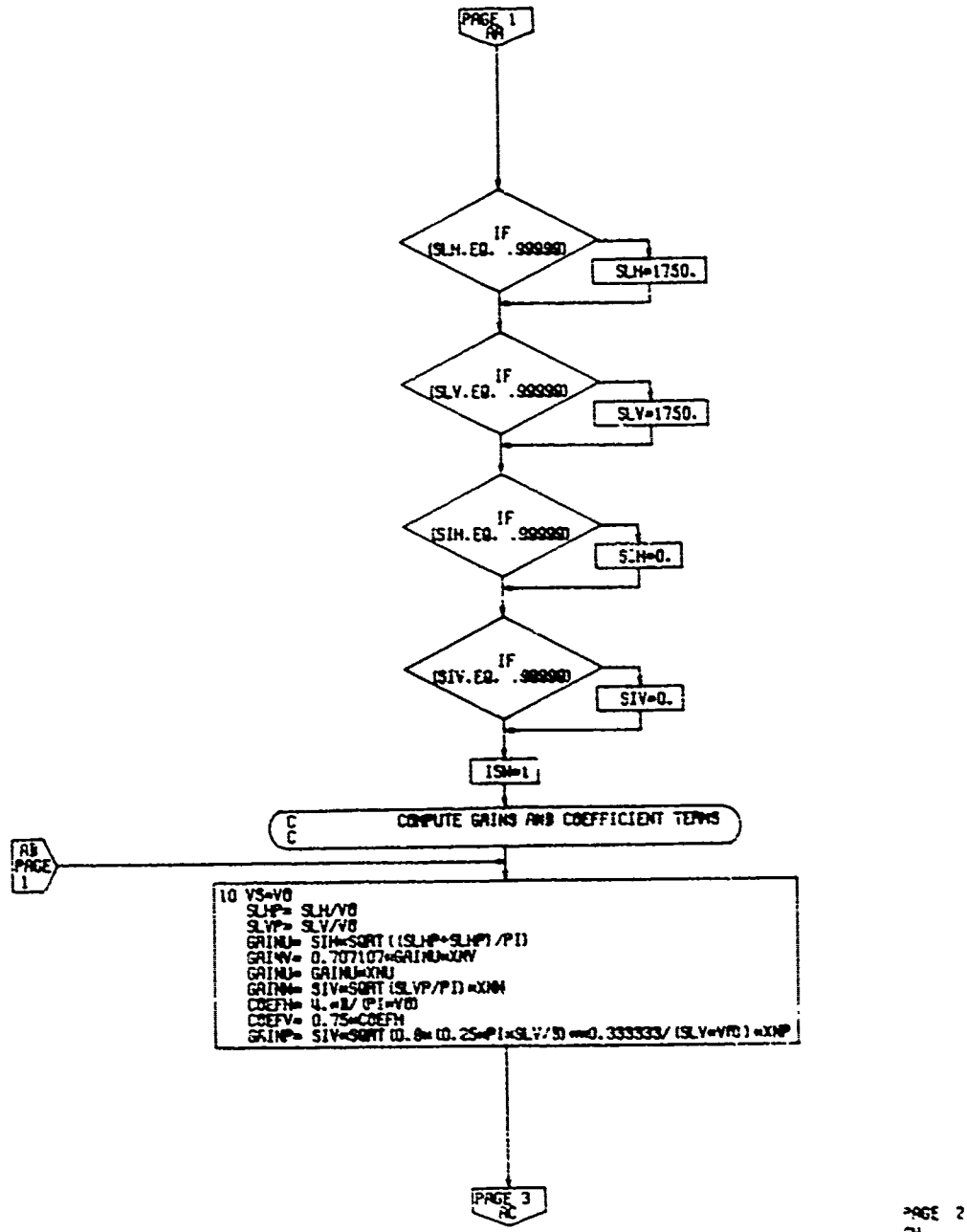

Table 45: FLOWCHART FOR SUBROUTINE GW (CONTINUED)



PAGE 2
24

Table 45: FLOWCHART FOR SUBROUTINE GW (CONCLUDED)

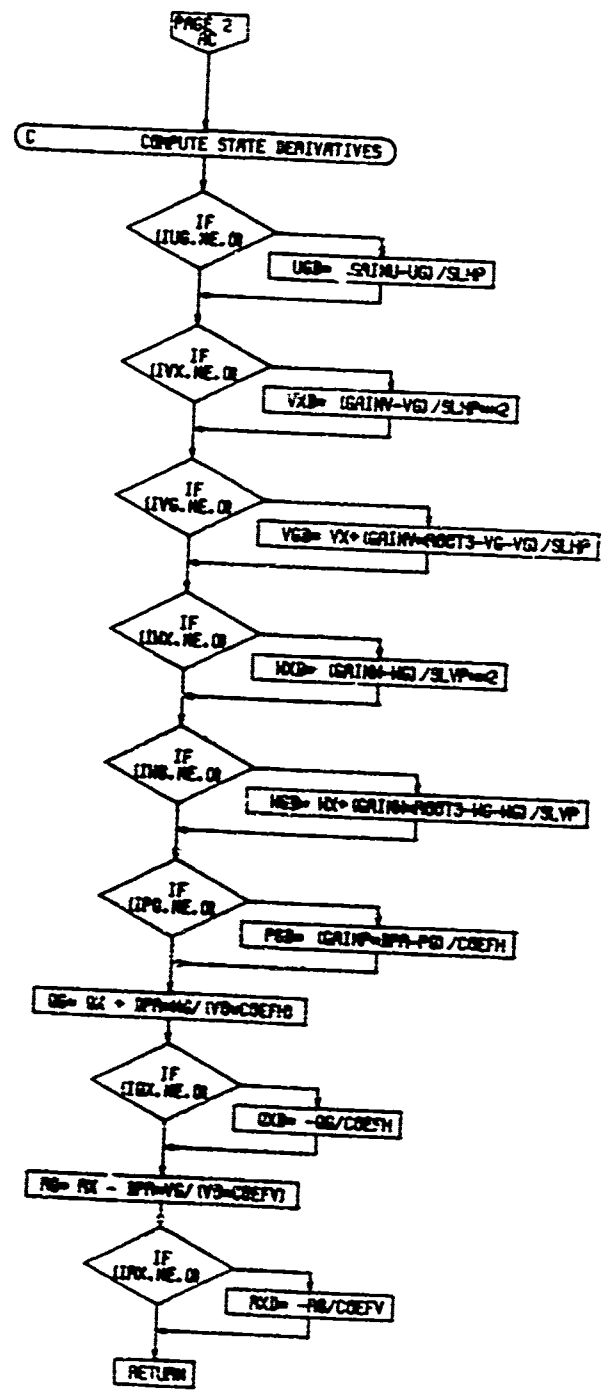

Table 46: FLOWCHART FOR SUBROUTINE HI

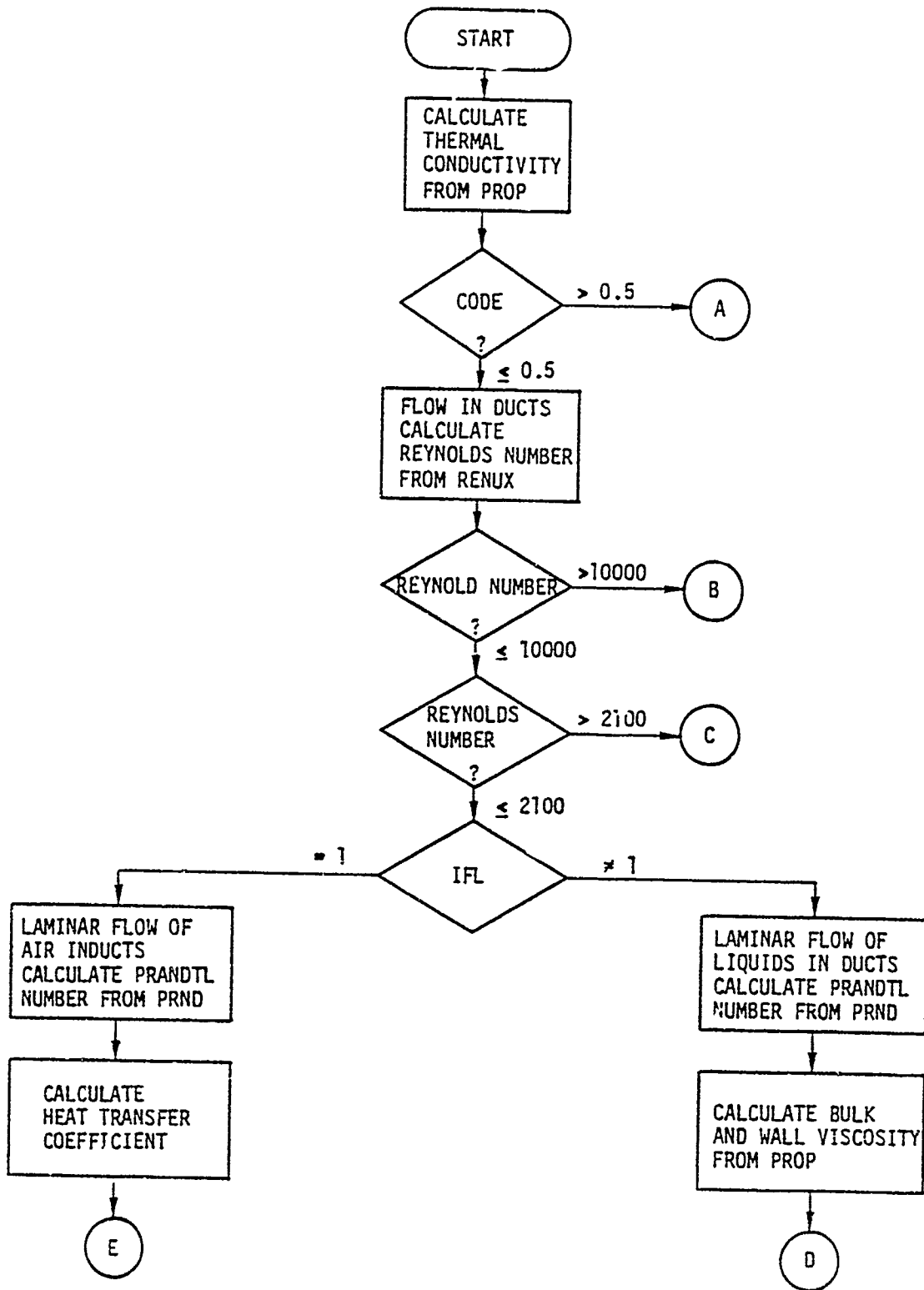

Table 46: FLOWCHART FOR SUBROUTINE HI (CONTINUED)

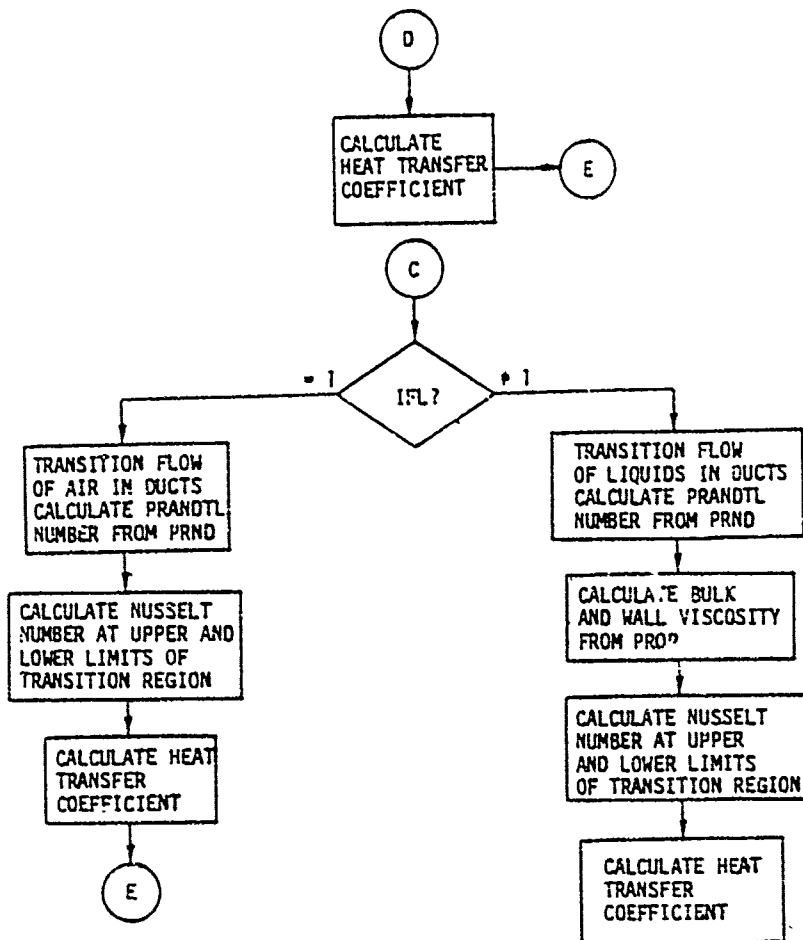

TABLE 3.3-12
FLOWCHART FOR FUNCTION
HI (CONTINUED)

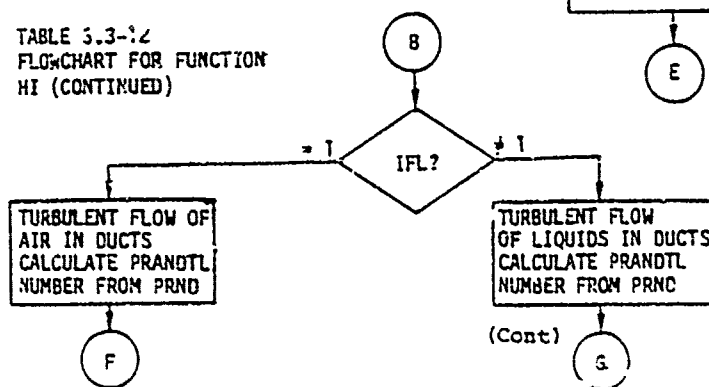

Table 16: FLOWCHART FOR SUBROUTINE III (CONCLUDED)

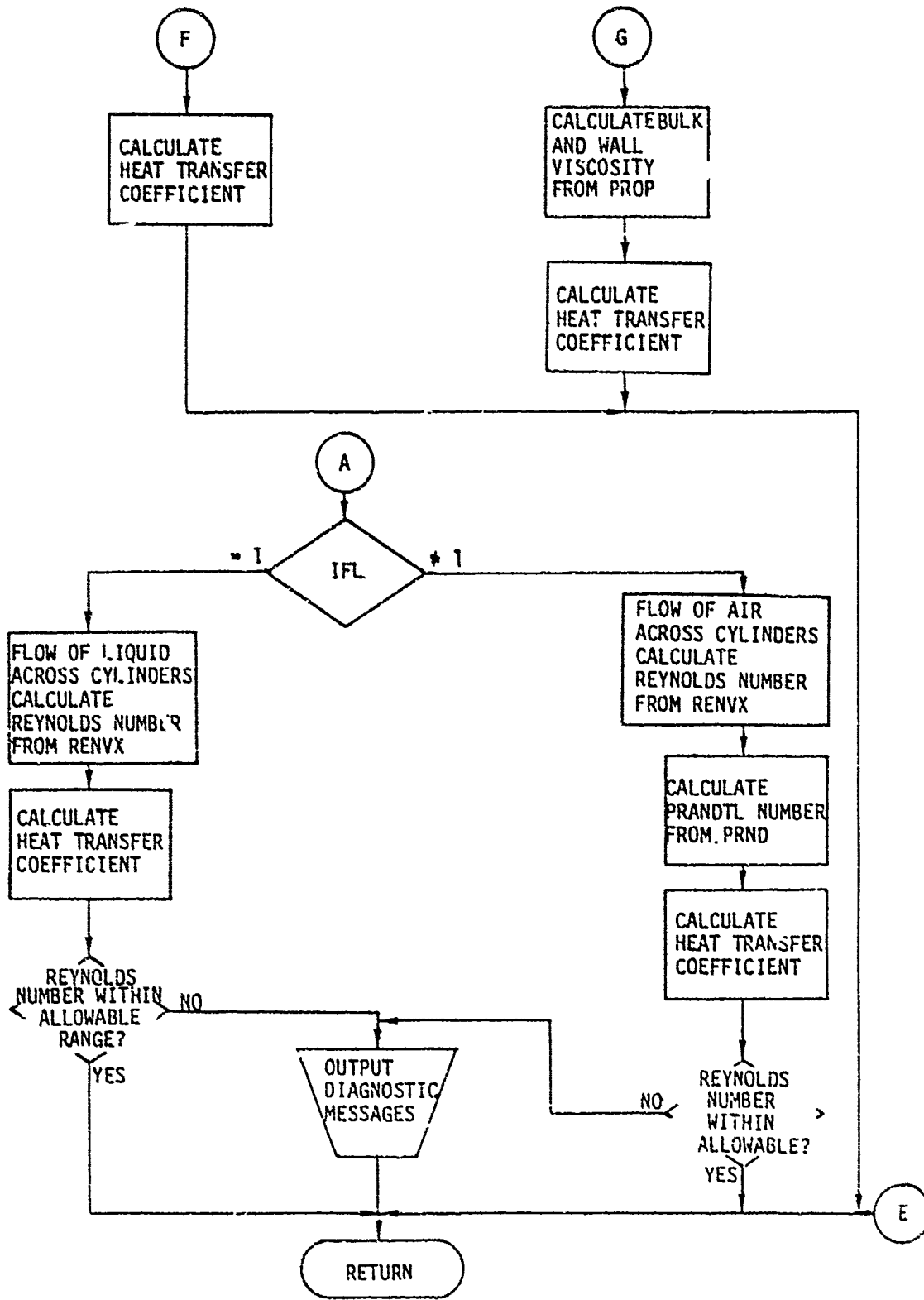

Table 47: FLOWCHART FOR SUBROUTINE HYCURV

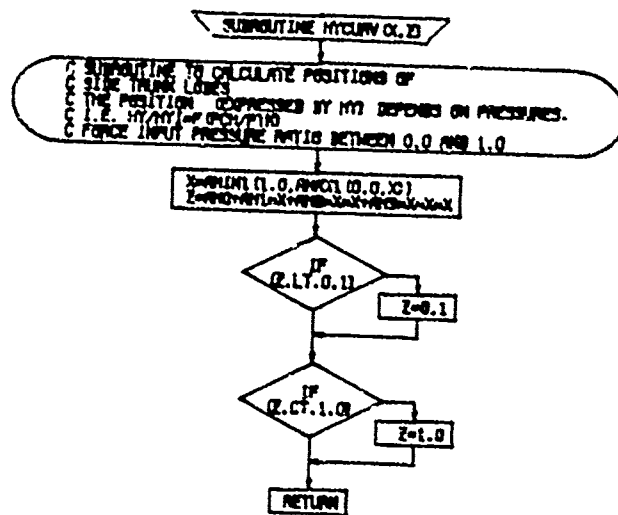

Table 48: FLOWCHART FOR SUBROUTINE IC

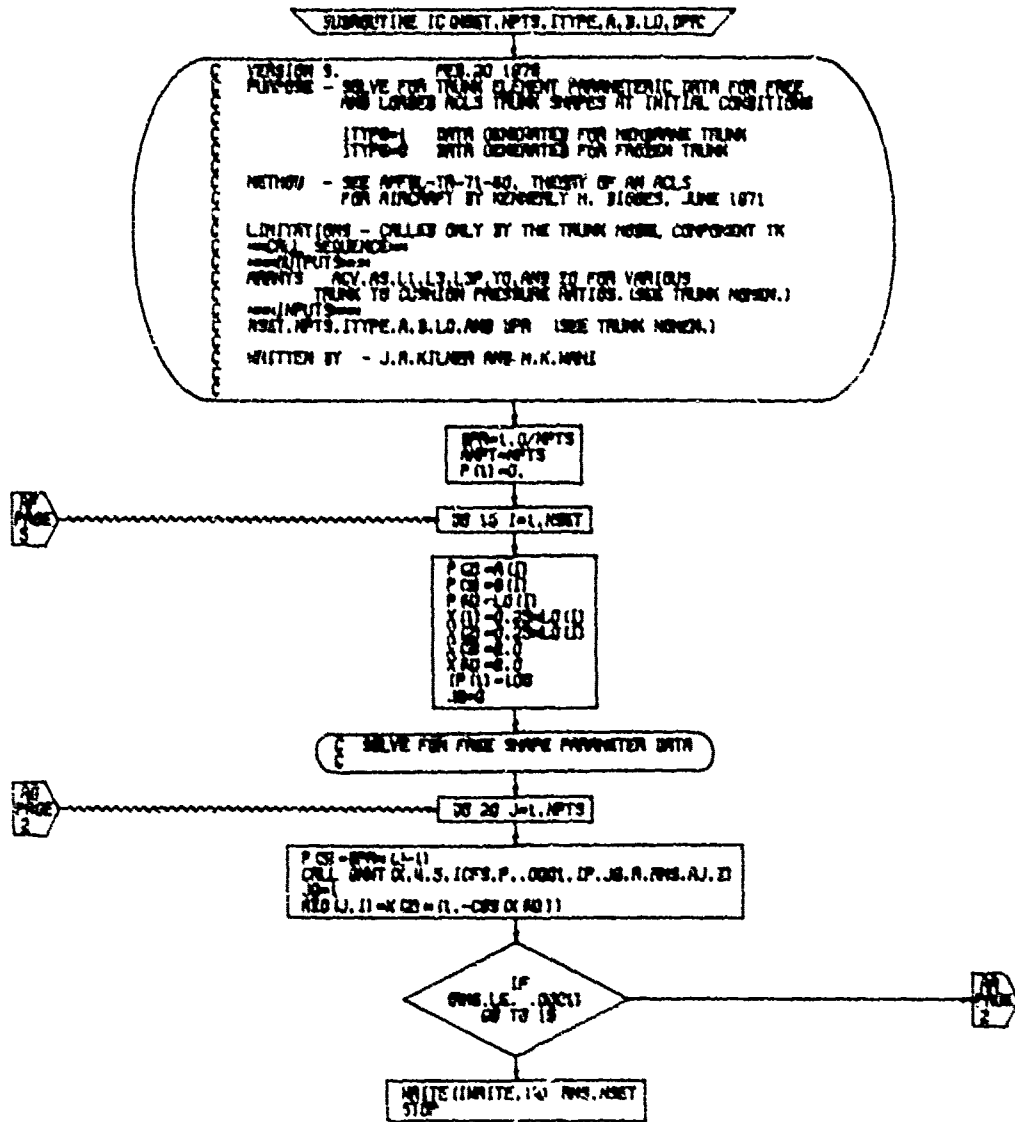
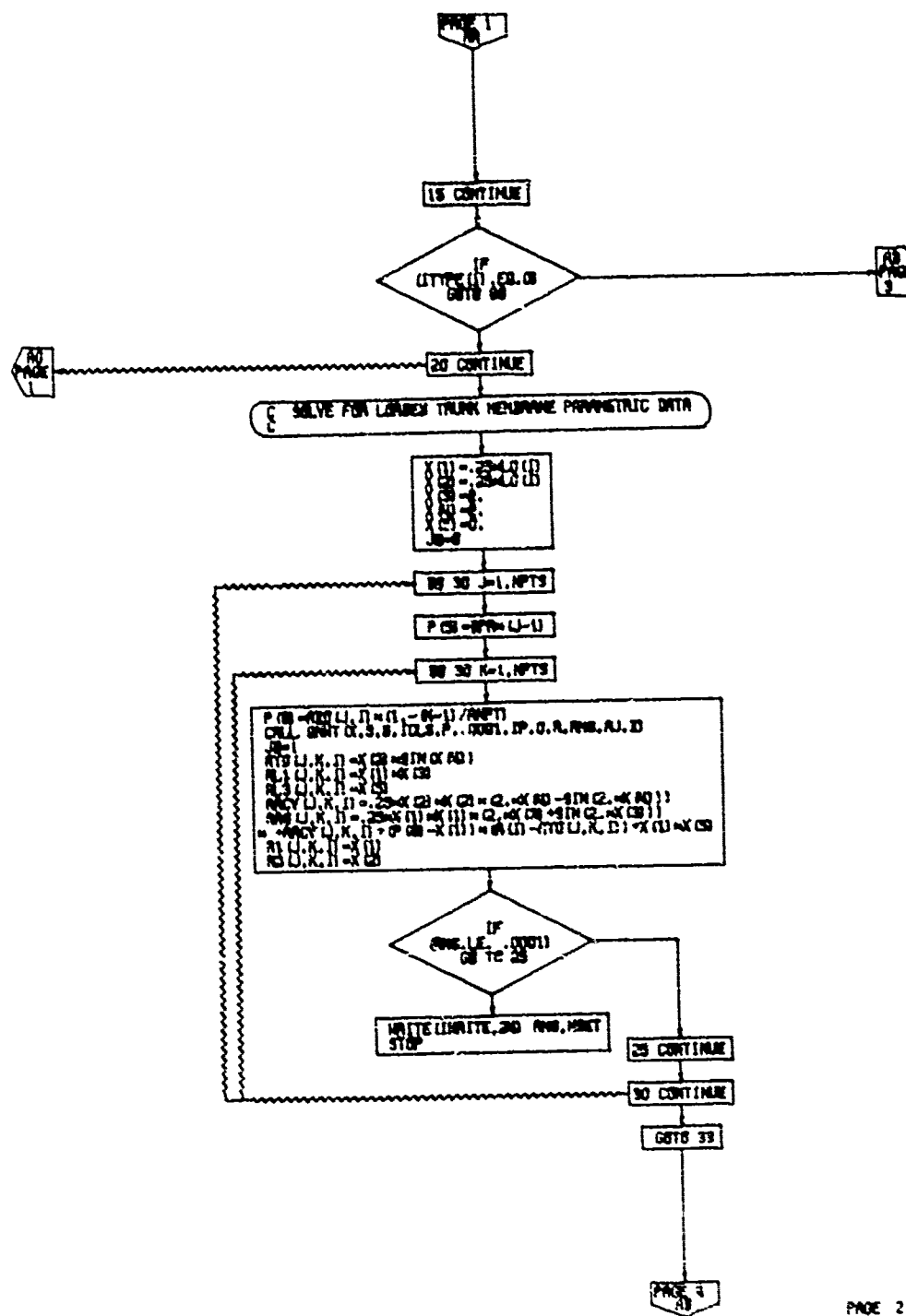

Table 48: FLOWCHART FOR SUBROUTINE IC (CONTINUED)



PAGE 2
IC

Table 48: FLOWCHART FOR SUBROUTINE IC (CONTINUED)

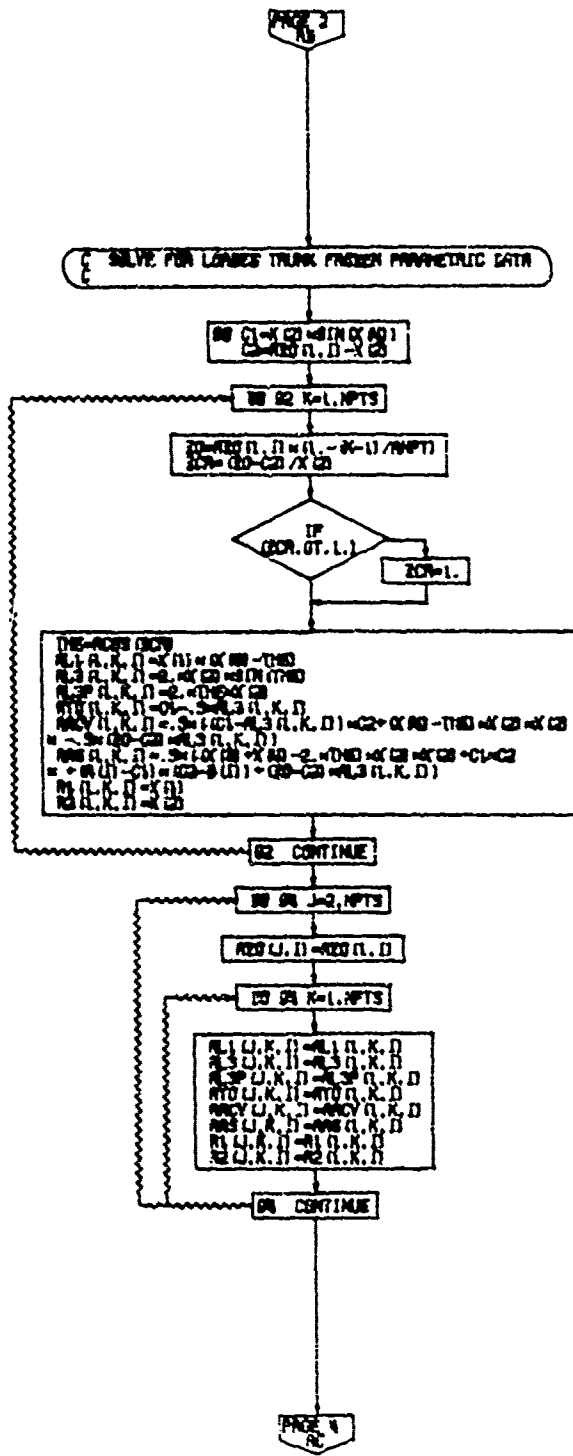
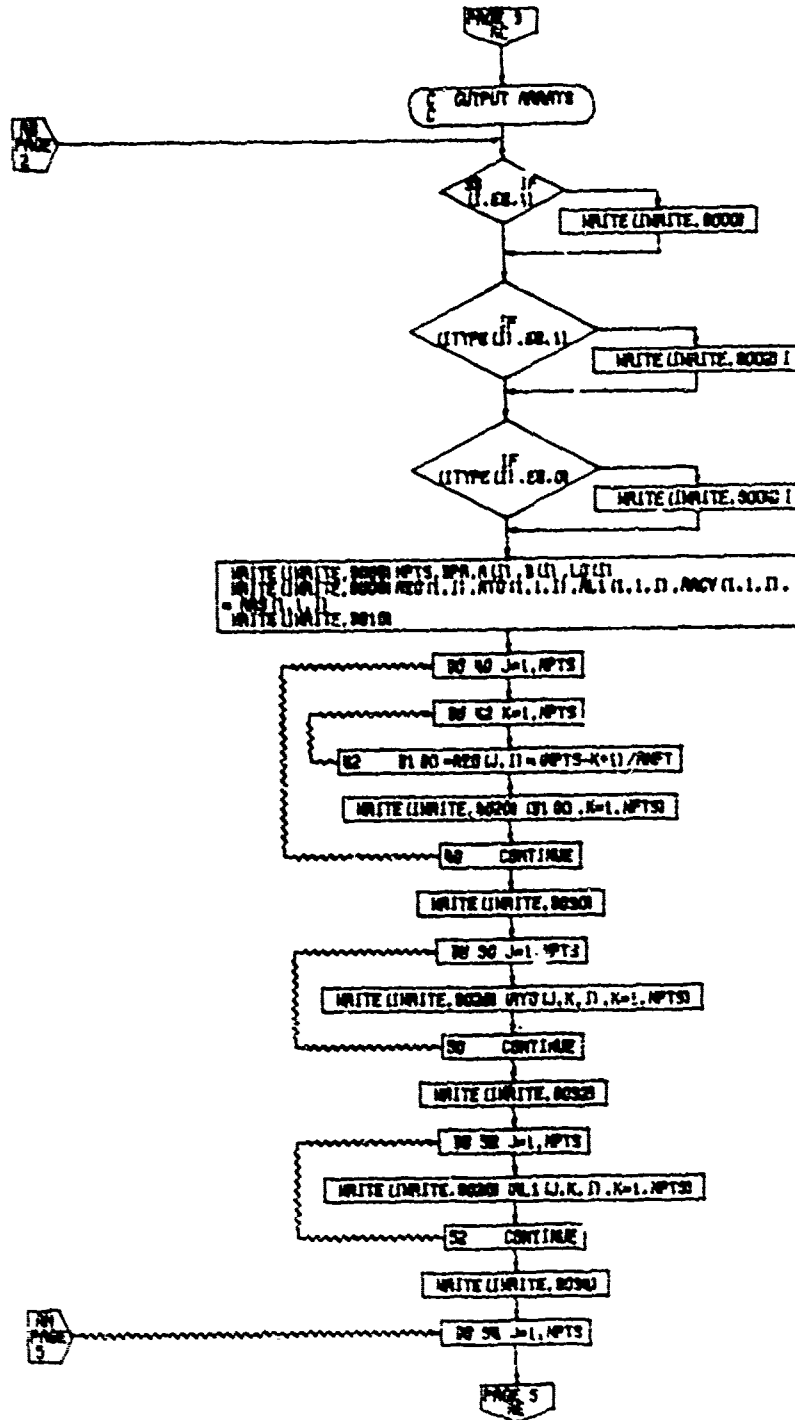
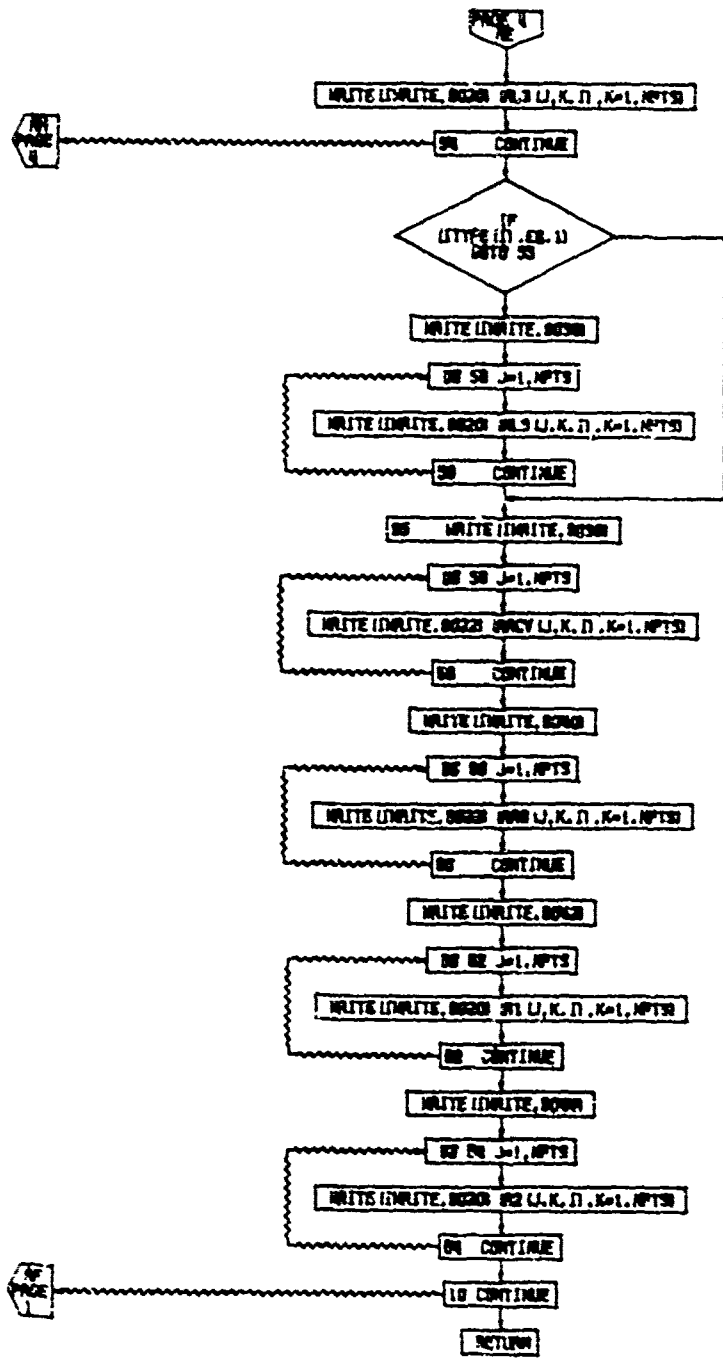

Table 48: FLOWCHART FOR SUBROUTINE IC (CONTINUED)



PAGE 4
IC

Table 48: FLOWCHART FOR SUBROUTINE IC (CONCLUDED)



PAGE 5
IC

Table 49: FLOWCHART FOR SUBROUTINE ICS

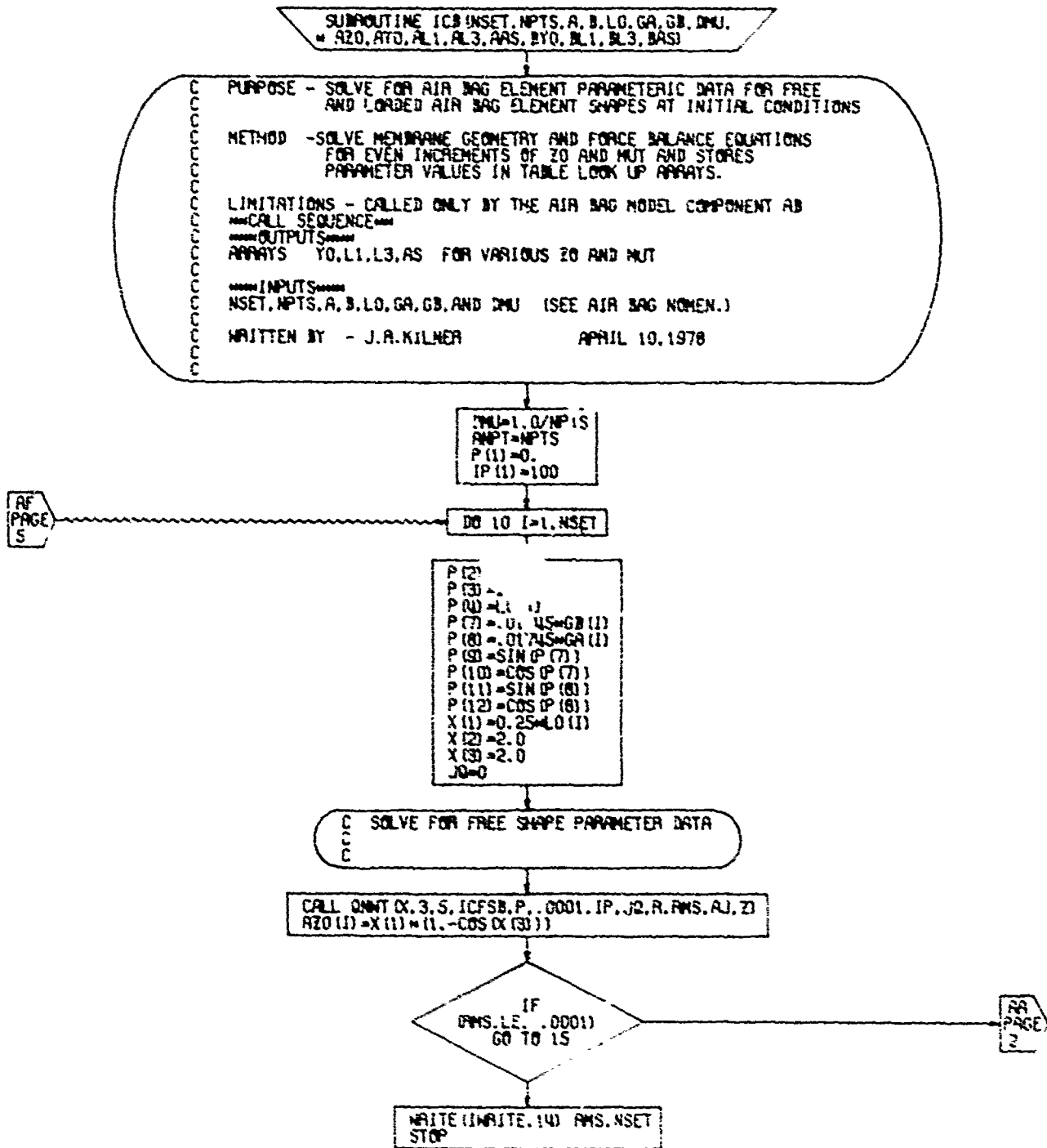

Table 49: FLOWCHART FOR SUBROUTINE ICB (CONTINUED)

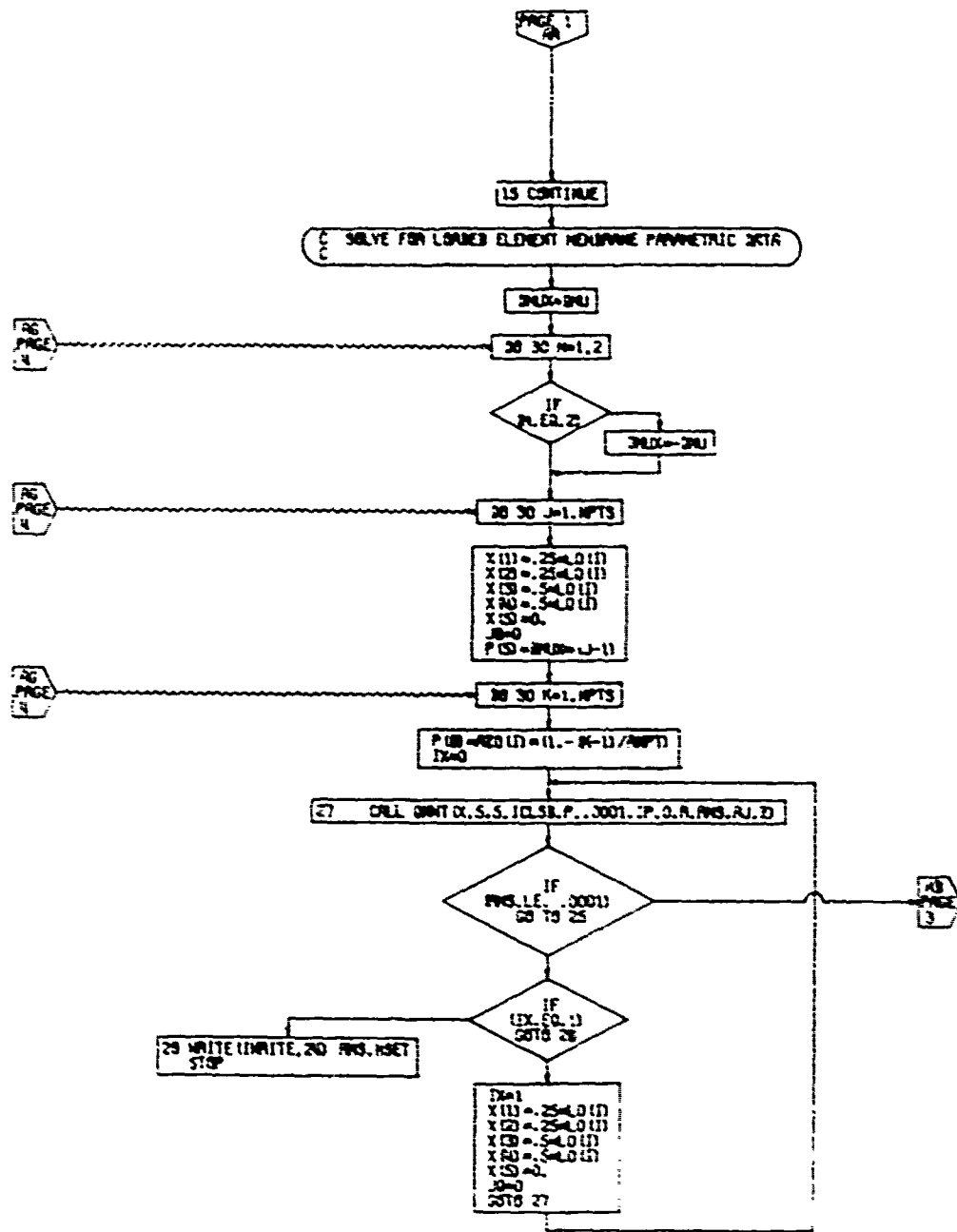
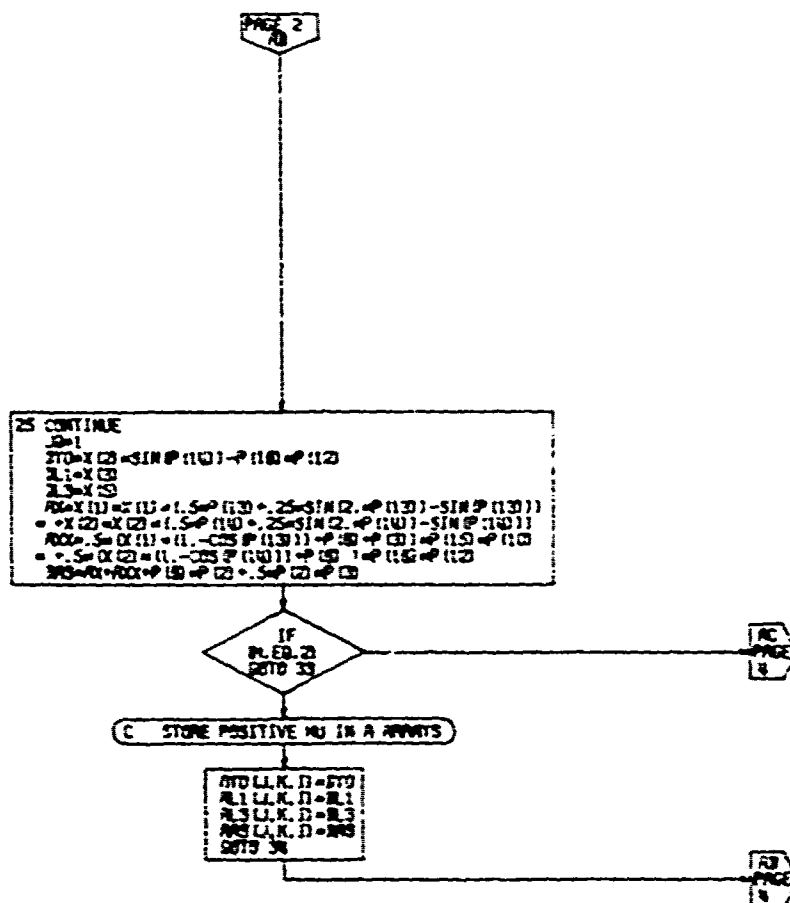
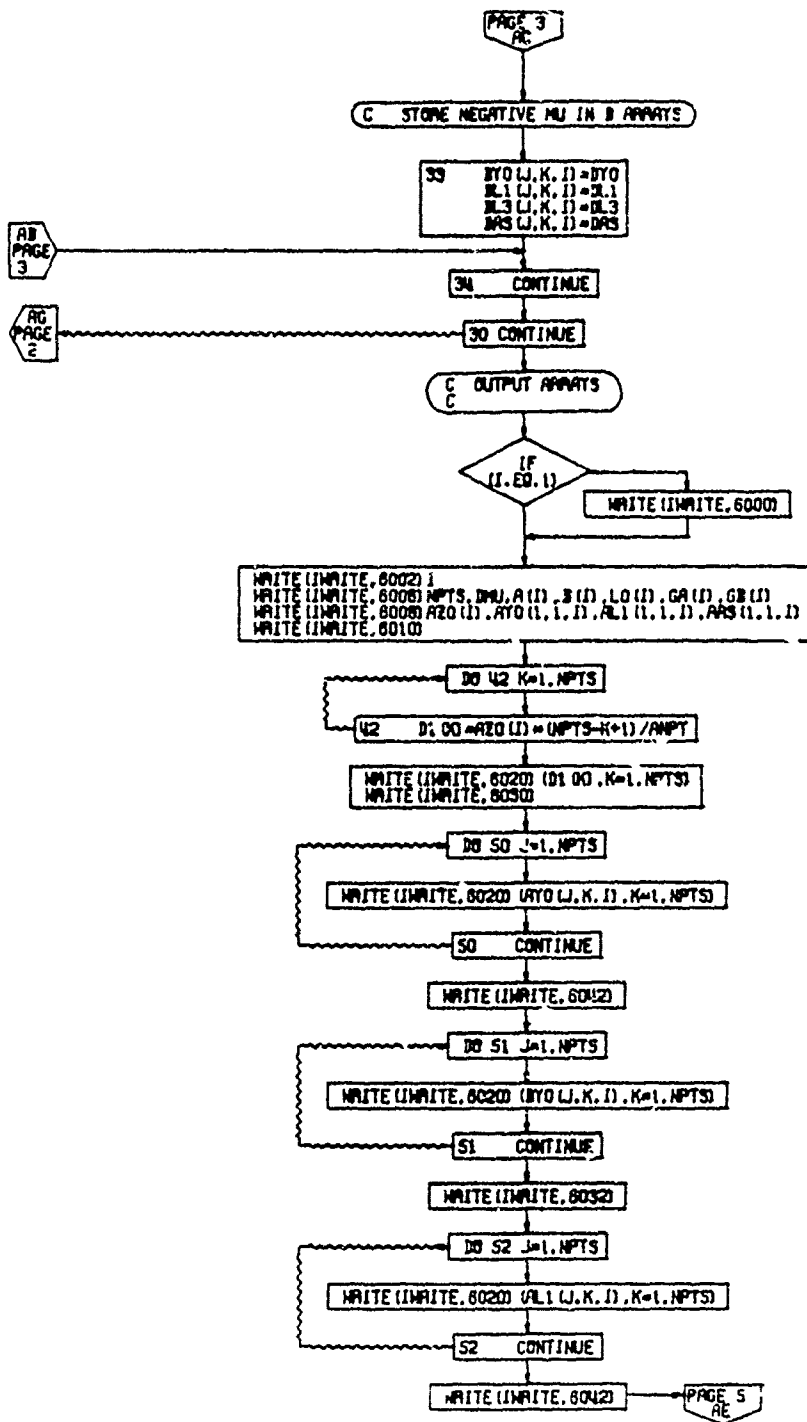

Table 49: FLOWCHART FOR SUBROUTINE ICB (CONTINUED)



27 3

Table 49: FLOWCHART FOR SUBROUTINE ICB (CONTINUED)



PAGE 4
ICB

Table 49: FLOWCHART FOR SUBROUTINE ICB (CONCLUDED)

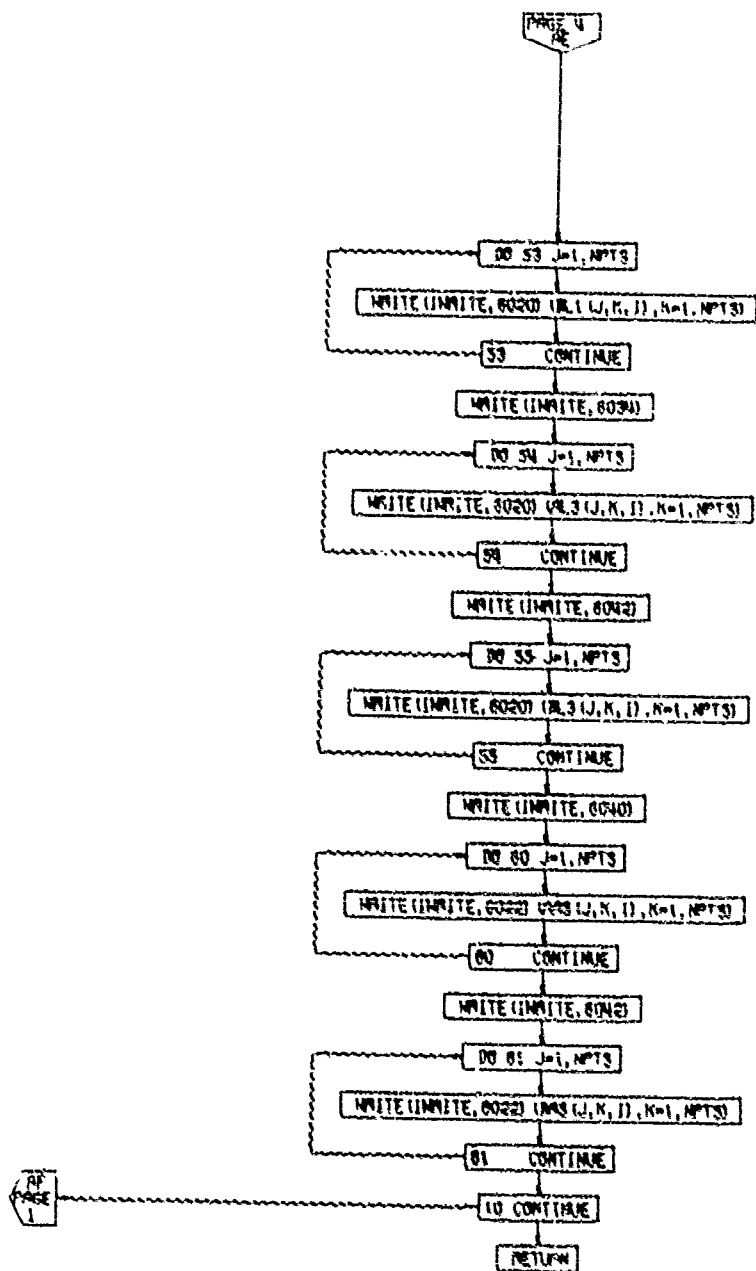

Table 50: FLOWCHART FOR SUBROUTINE ICFS

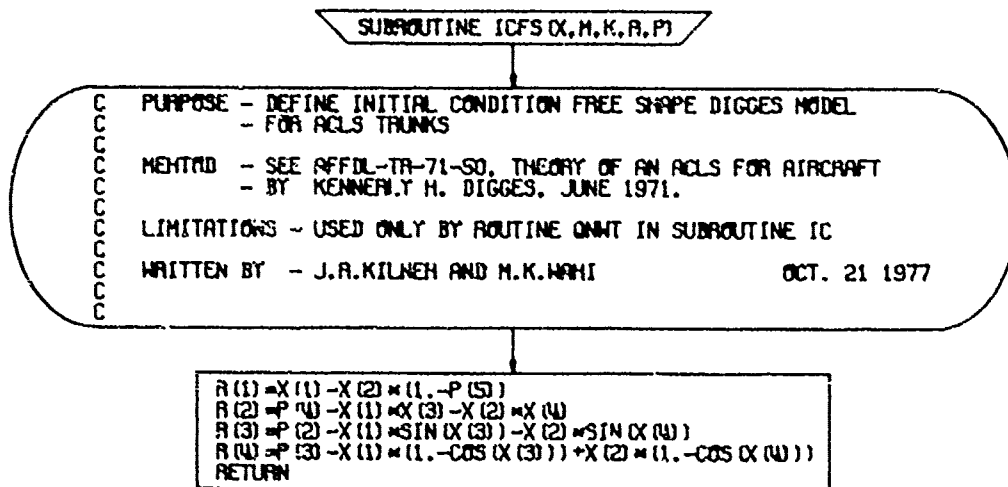

Table 51: FLOWCHART FOR SUBROUTINE ICFSB

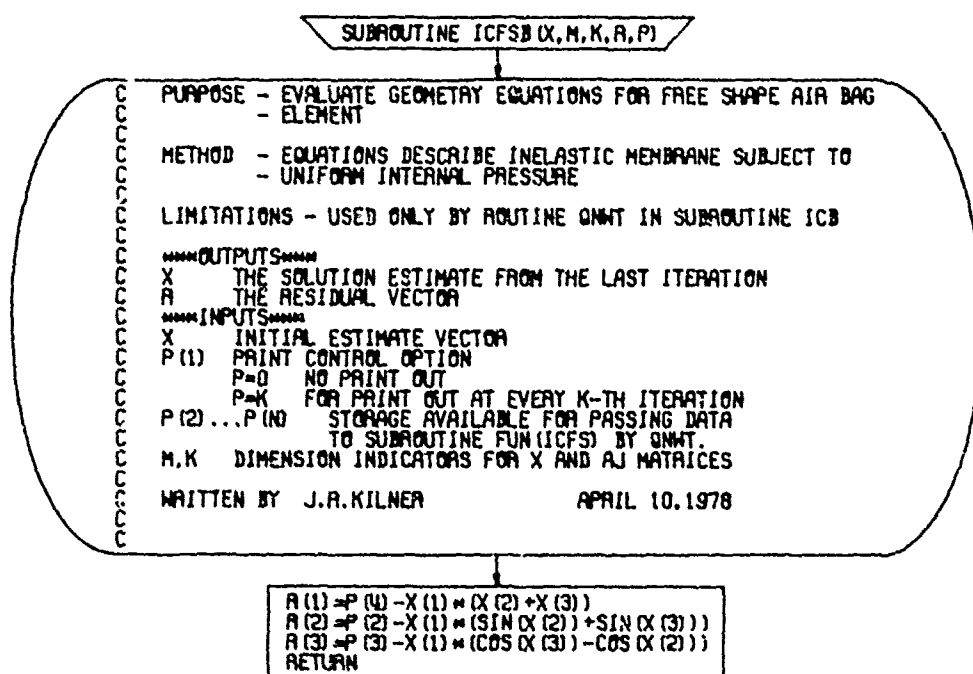

Table 52: FLOWCHART FOR SUBROUTINE ICLS

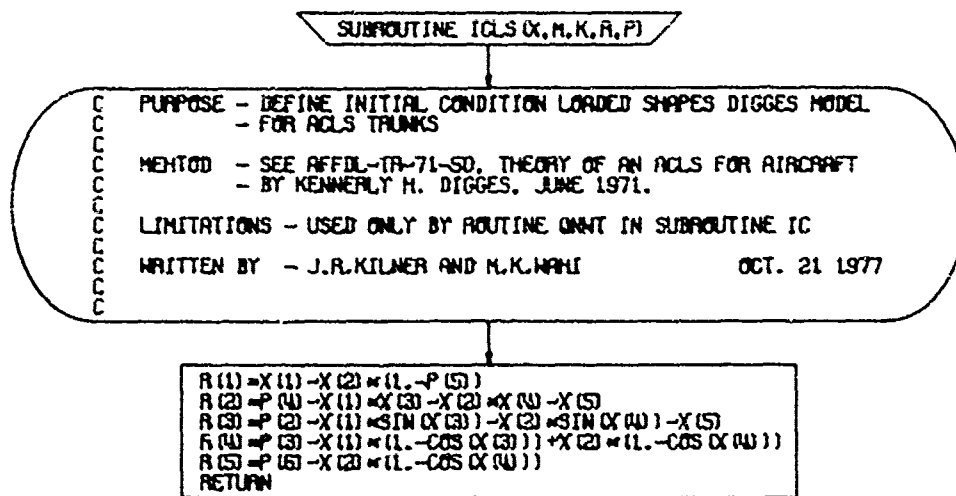

Table 53: FLOWCHART FOR SUBROUTINE ICLSB

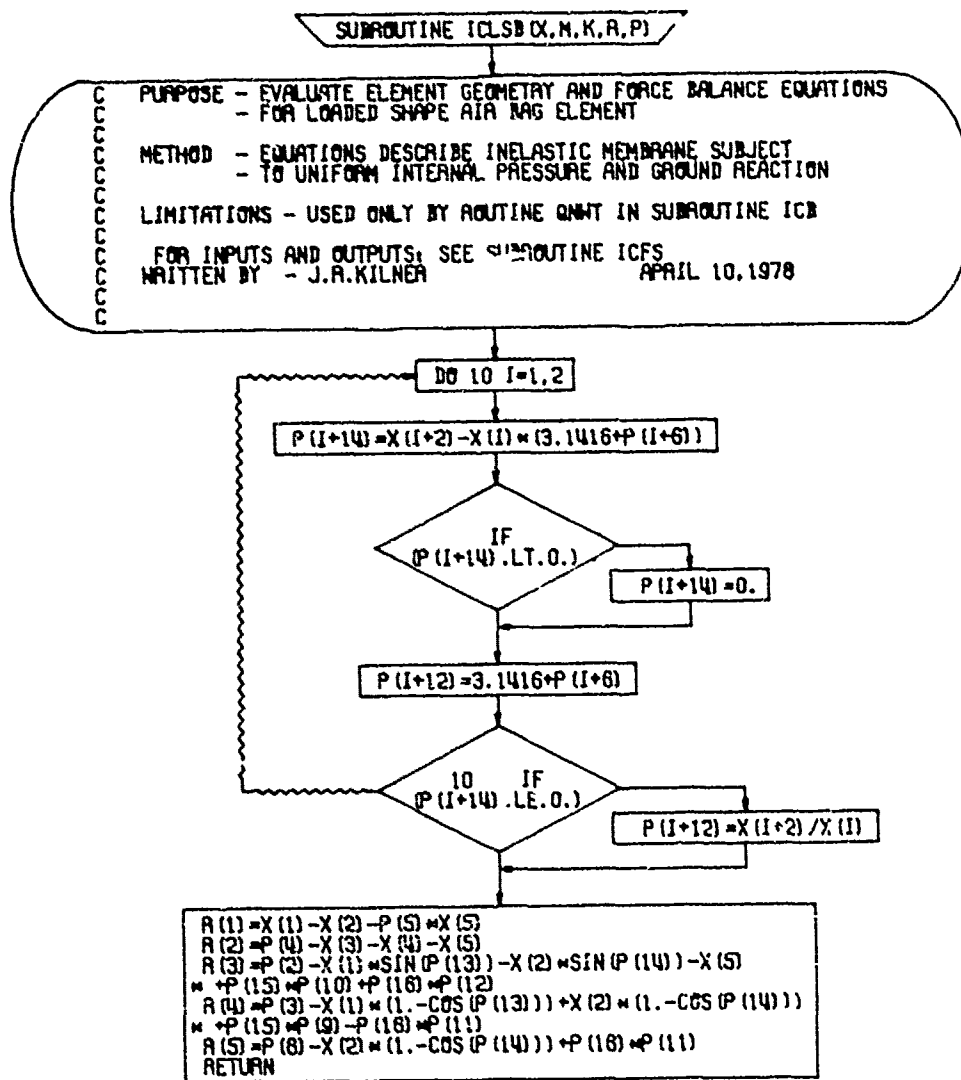

Table 54: FLOWCHART FOR SUBROUTINE IT

SUBROUTINE IT (FO, FODOT, IFO, FIN, GKI, GKL, AMA, AMI)

C VERSION 2. REVISID: OCT 8 1976
 C PURPOSE - SIMULATION OF AN INTEGRATOR WITH SATURATION
 C METHOD - SEE CODING
 C LIMITATIONS - EXCESSIVELY HIGH VALUES OF GKL MAY RESULT IN POOR
 C STEADY STATE CONVERGENCE
 C WRITTEN BY - ADAM LLOYD LATEST REVISION - NOV 75
 C INPUT/OUTPUT LIST
 C

FO	INTEGRATOR OUTPUT	ANY	OUTPUT STATE
FODOT	OUTPUT DERIVATIVE	ANY	OUTPUT DERIV
IFO	INTEGRATOR CONTROL	---	PROGRAM VAR
FIN	FUNCTION INPUT	ANY	INPUT VAR
GKI	INTEGRATOR GAIN	ANY	INPUT PARAM
GKL	DERIVATIVE LIMITER GAIN	ANY	INPUT PARAM
AMA	UPPER LIMIT OF OUTPUT	ANY	INPUT PARAM
AMI	LOWER LIMIT OF OUTPUT	ANY	INPUT PARAM

C WHERE DERIV. LIMITER STARTS

EPS=FIN

PAGE 2
AA

PAGE 1
IT

Table 54: FLOWCHART FOR SUBROUTINE IT (CONCLUDED)

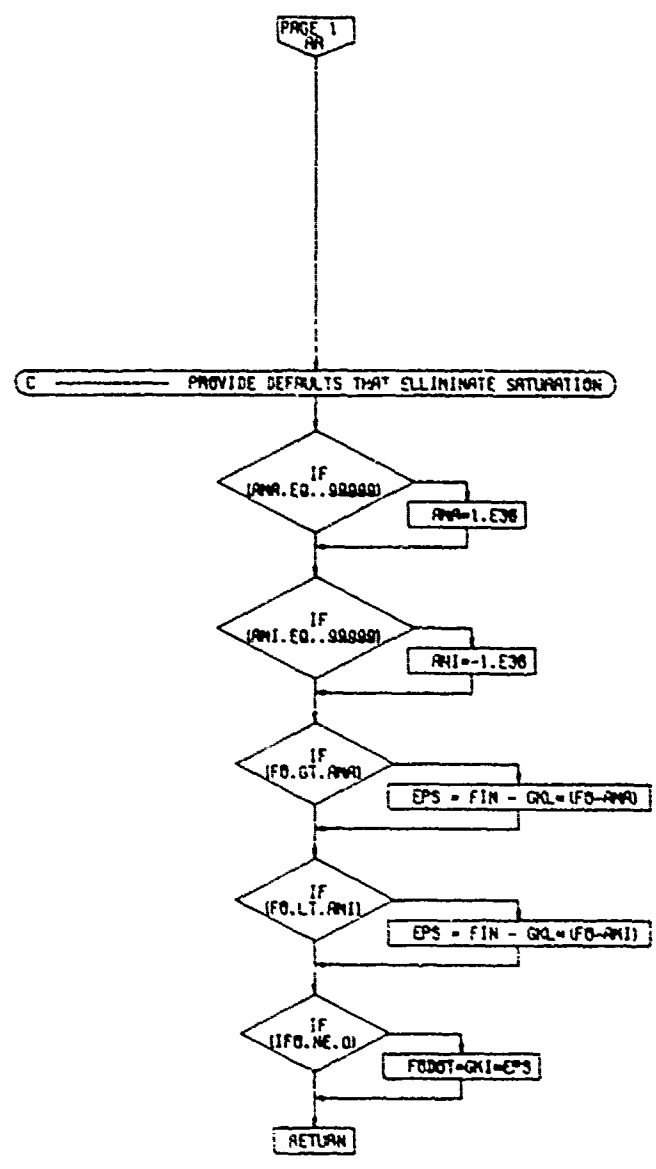

PAGE 2
IT

Table 55: FLOWCHART FOR SUBROUTINE KINK

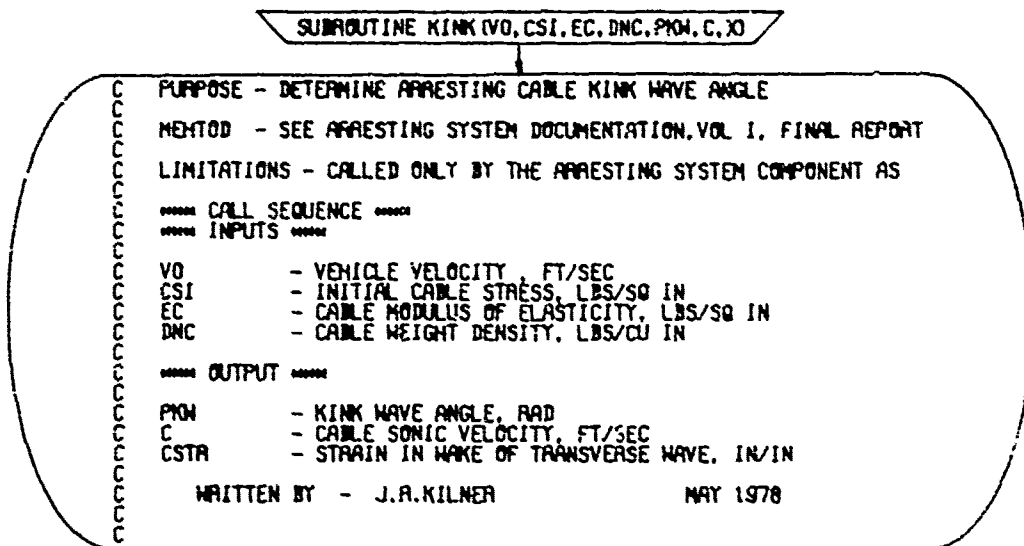

```

C=SQRT (386. *EC/DNC) /12.
VC=VO/C
P (2) =VC*VC
P (3) =CSI/EC
X (1) =P (3)
P (1) =0.
IP (1) =50
CALL QMNT (X, 1, 1, RES, P, .0001, IP, O, R, RMS, AJ, 3D)
SINPKM=VC/SQRT (X (1) * (1. +X (1)))
PKM=ASIN (SINPKM)
RETURN
  
```

Table 56: FLOWCHART FOR SUBROUTINE LA

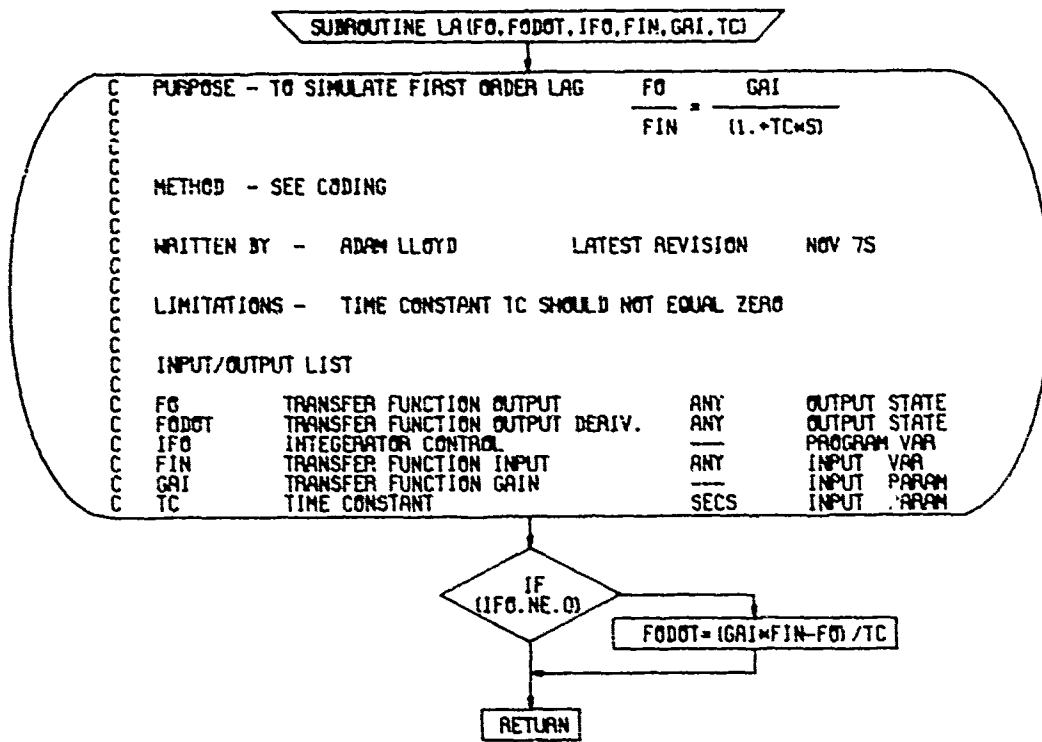

Table 57: FLOWCHART FOR SUBROUTINE LE

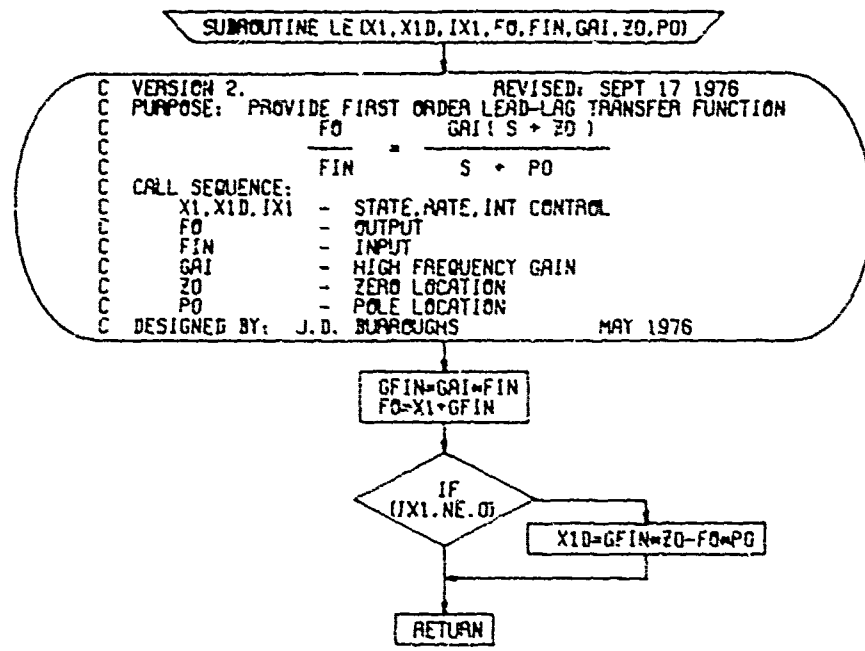

Table 58: FLOWCHART FOR SUBROUTINE LG

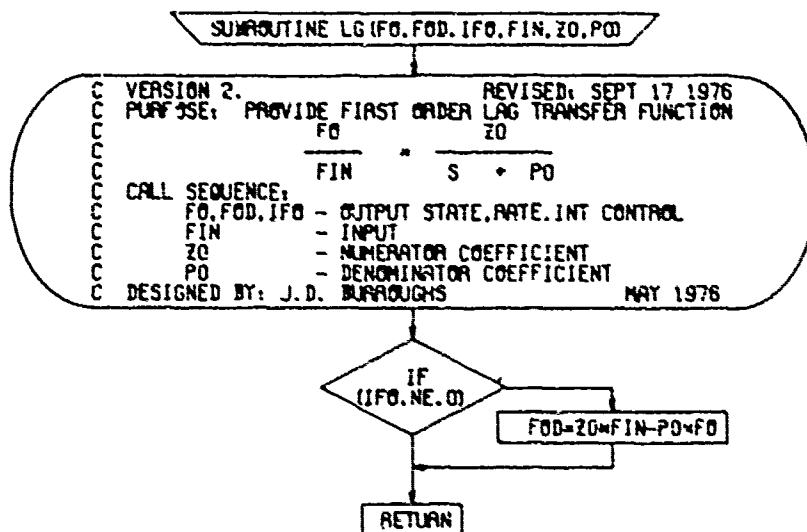

Table 59: FLOWCHART FOR SUBROUTINE LL

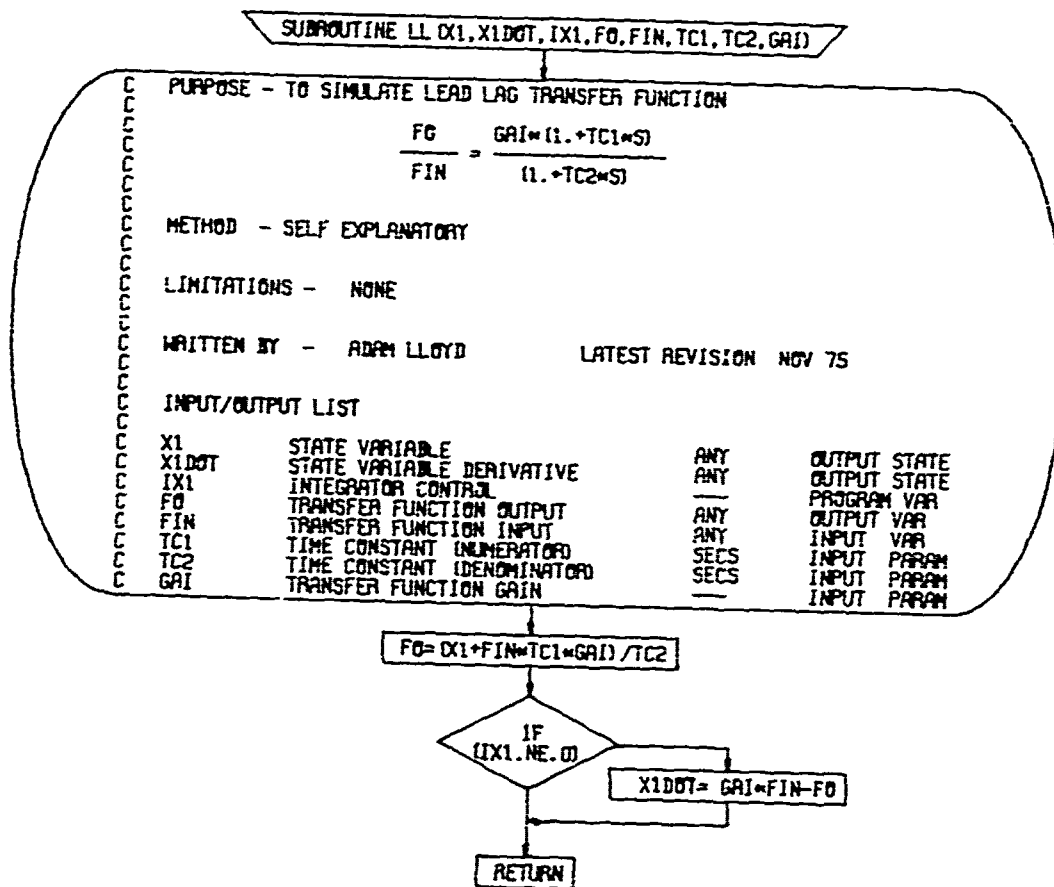

Table 60: FLOWCHART FOR SUBROUTINE MA

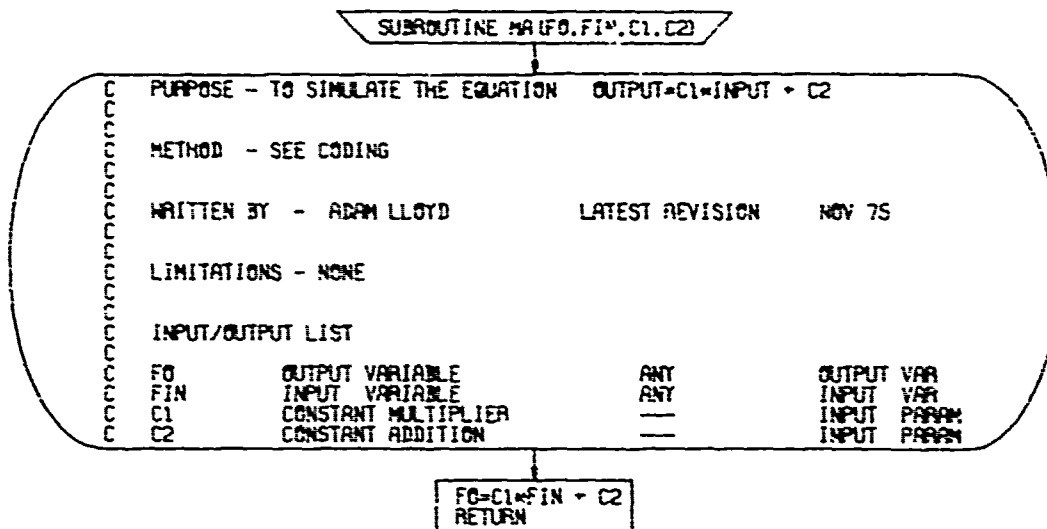

Table 61: FLOWCHART FOR SUBROUTINE MB

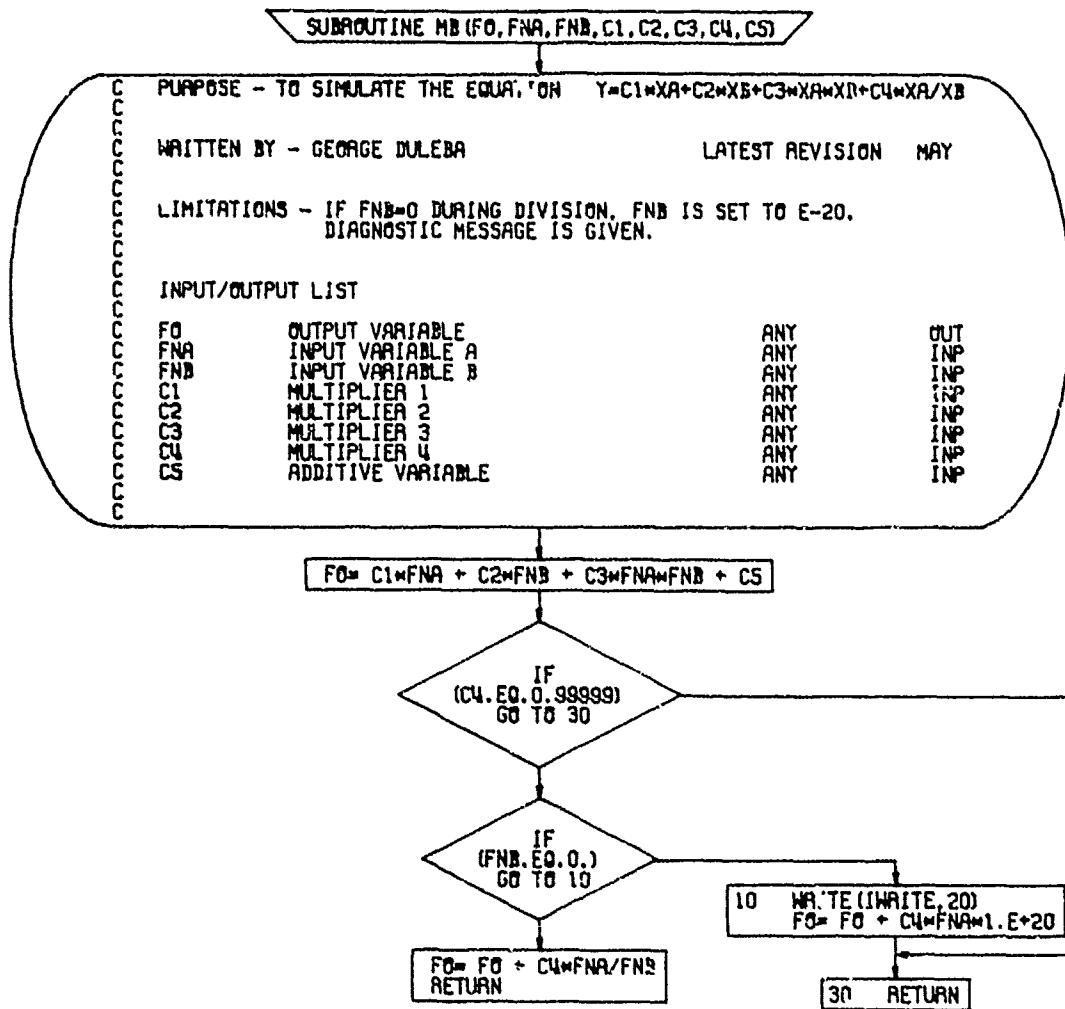

Table 62: FLOWCHART FOR SUBROUTINE MC

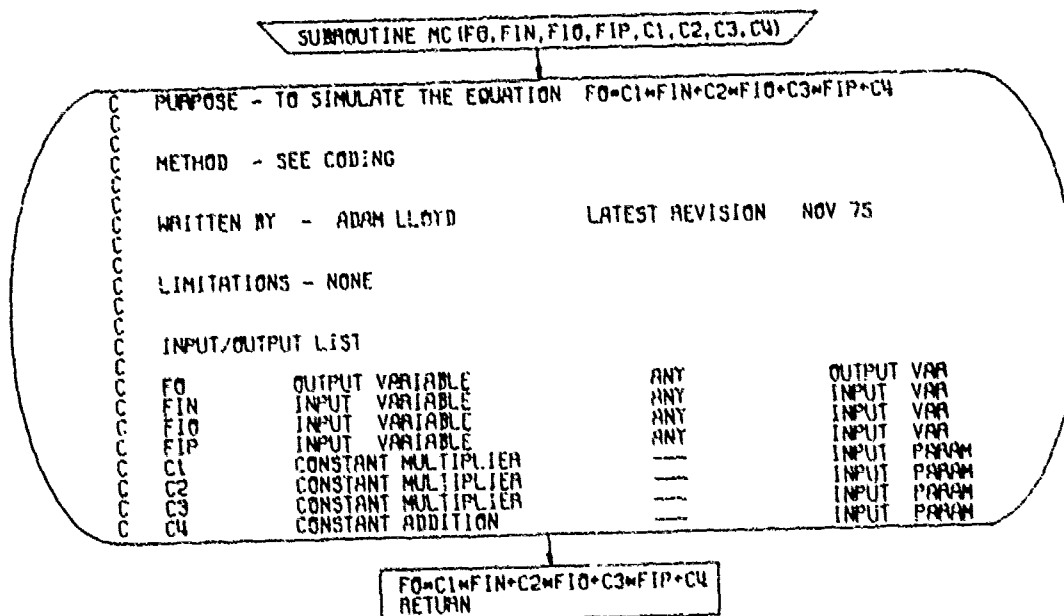

Table 63: FLOWCHART FOR SUBROUTINE MG

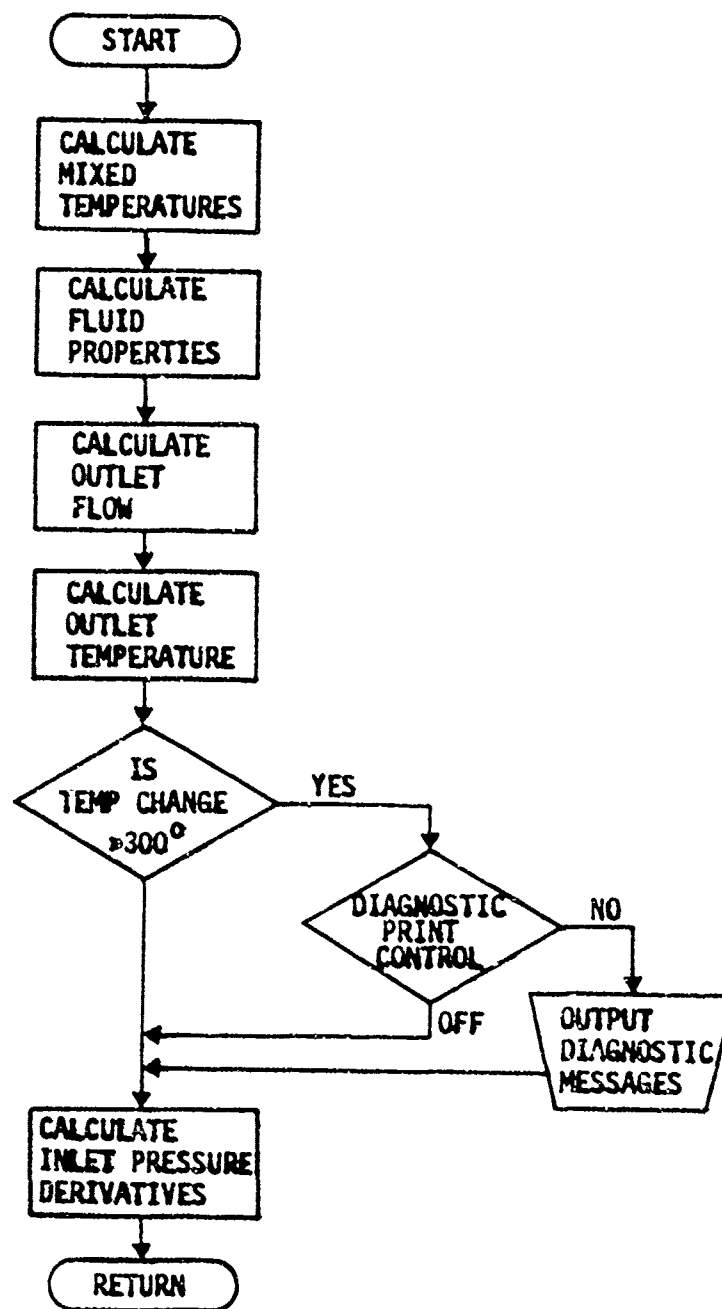
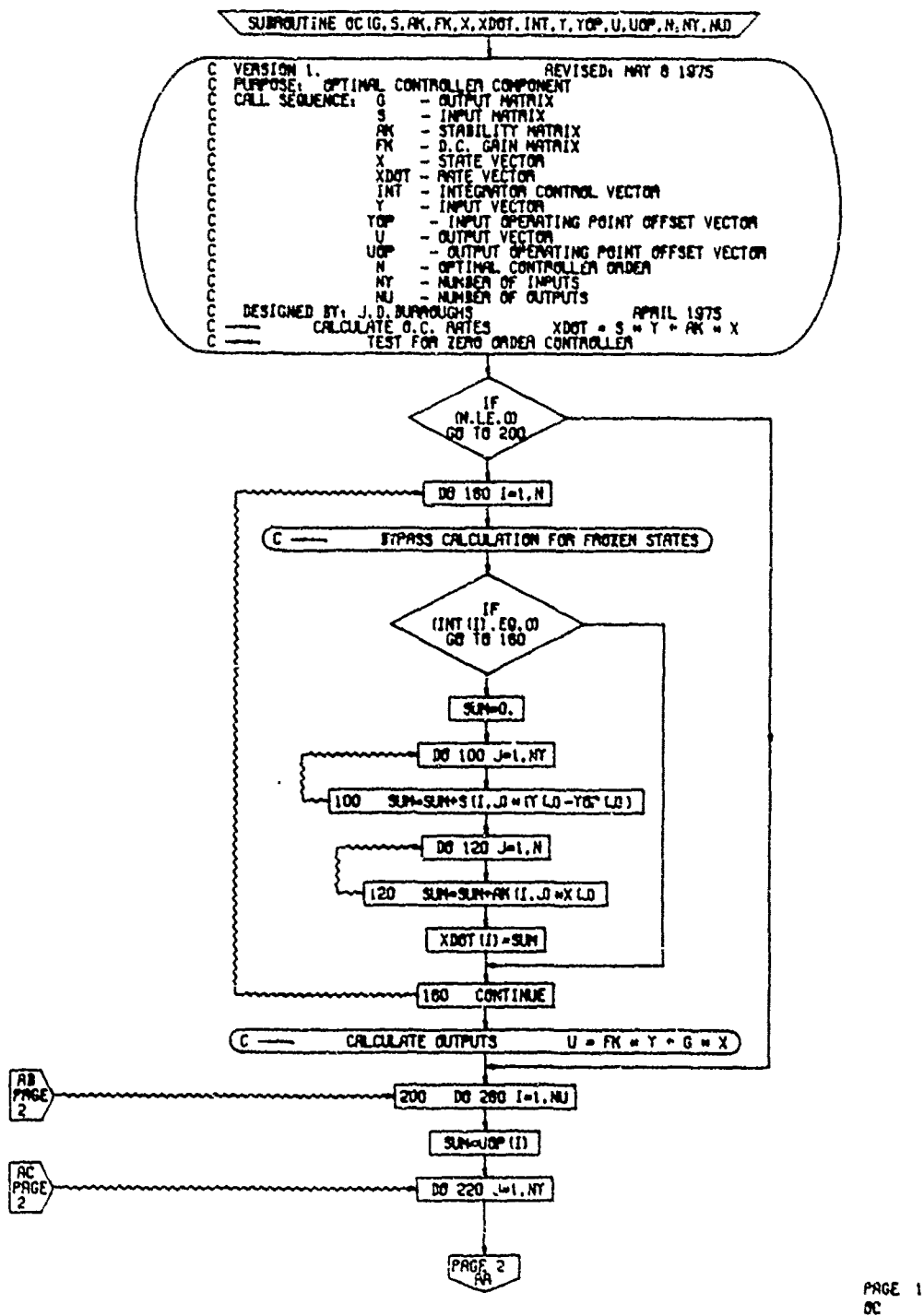
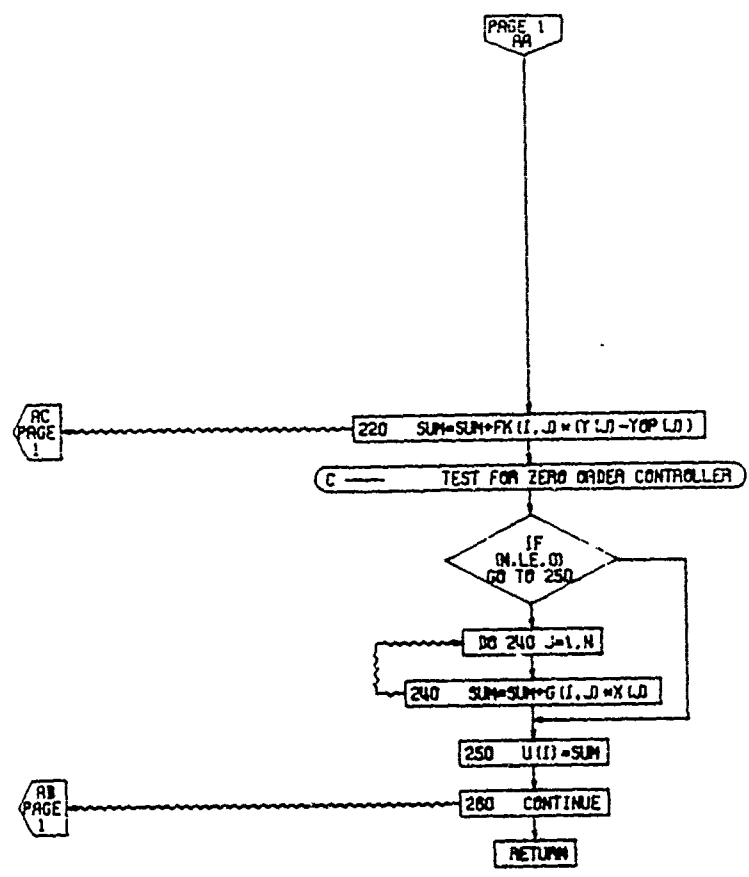

Table 64: FLOWCHART FOR SUBROUTINE OC



PAGE 1
OC

Table 64: FLOWCHART FOR SUBROUTINE OC (CONCLUDED)



PAGE 2
OC

Table 65: FLOWCHART FOR SUBROUTINE OL

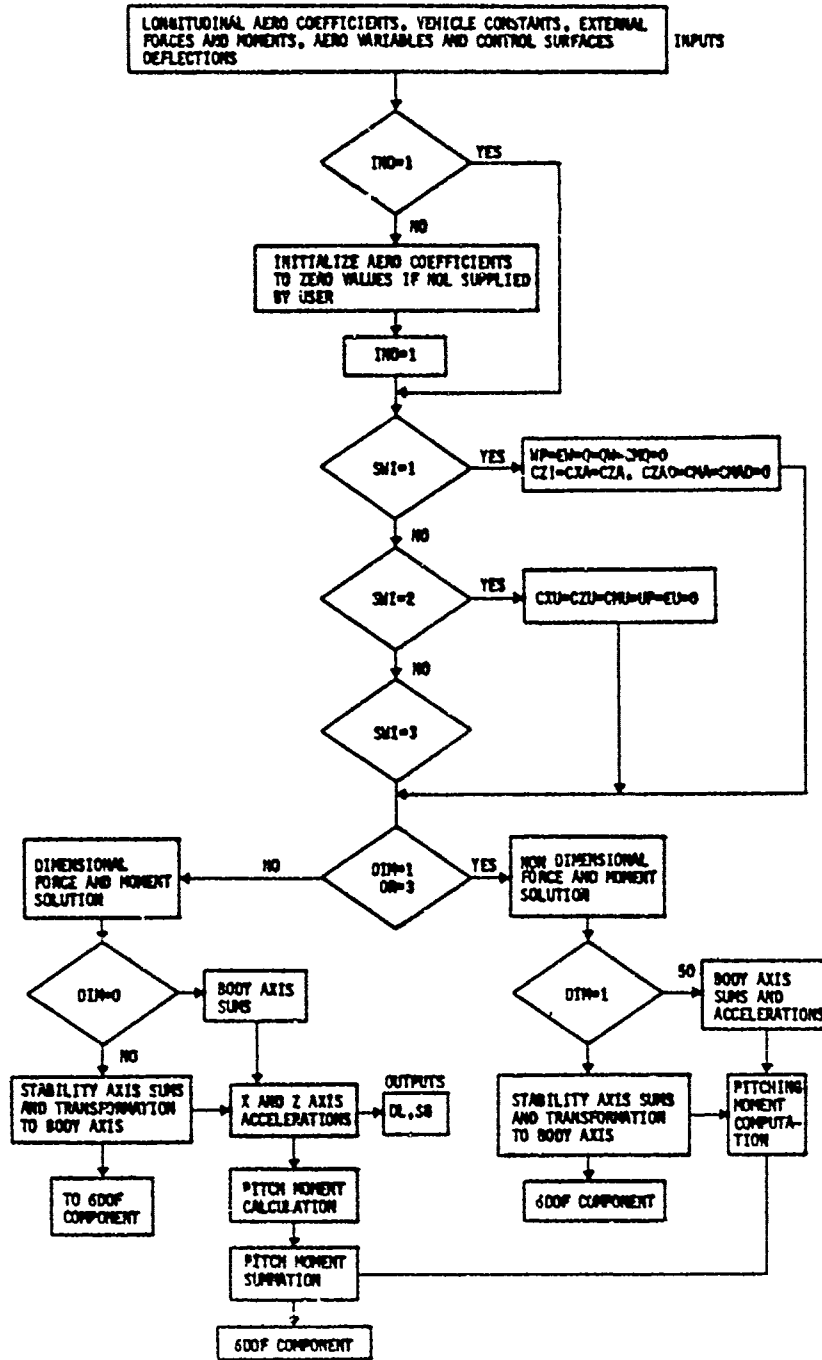
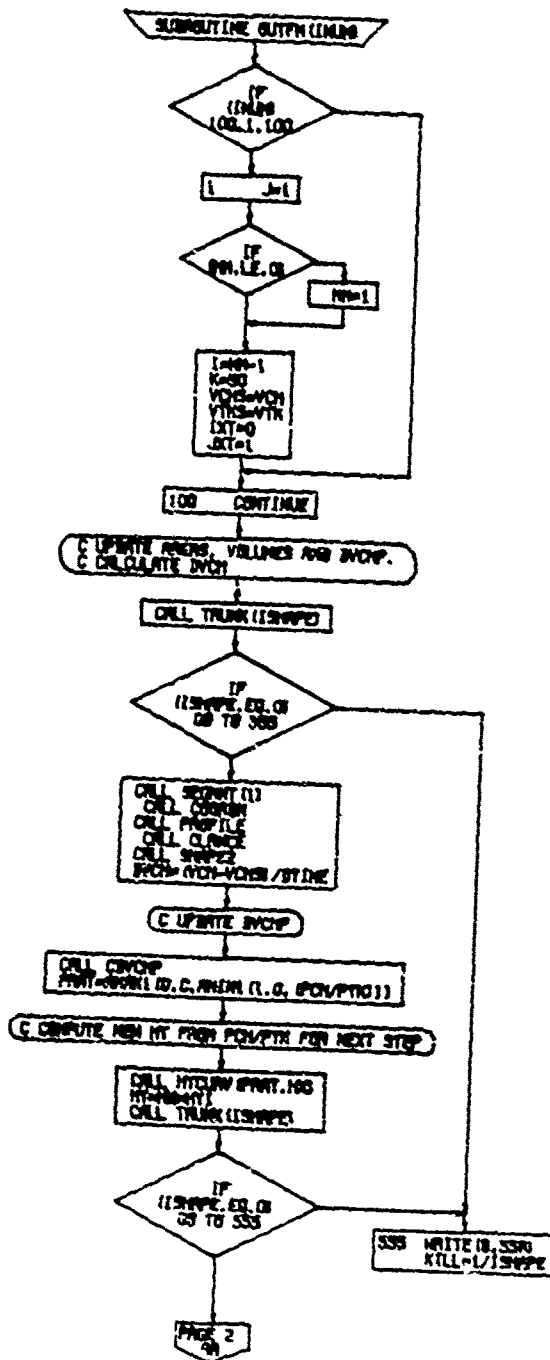
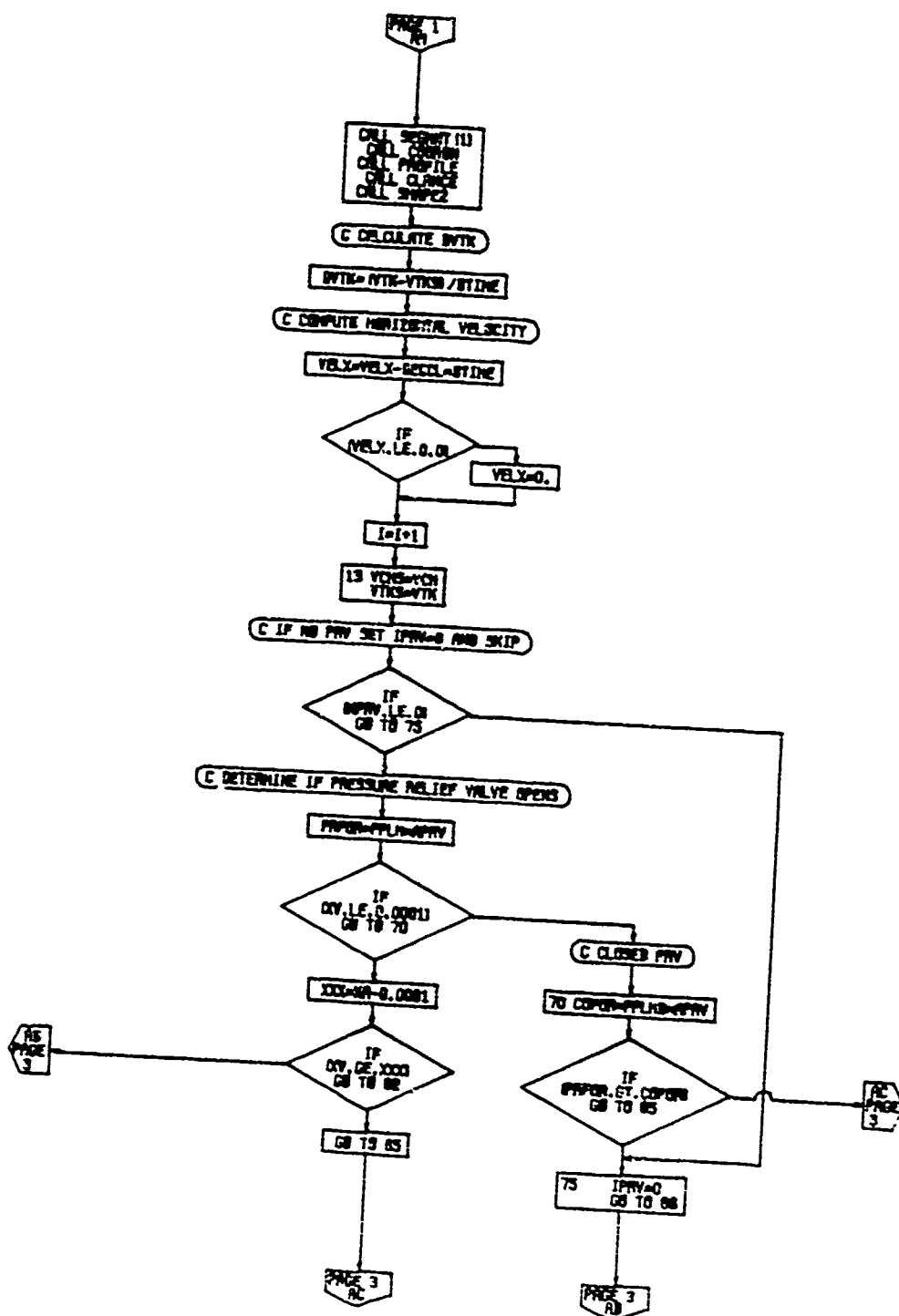

Table 67: FLOWCHART FOR SUBROUTINE OUTFM



PAGE 1
OUTFM

Table 67: FLOWCHART FOR SUBROUTINE OUTFM (CONTINUED)



PAGE 2
OUTFM

Table 67: FLOWCHART FOR SUBROUTINE OUTFM (CONCLUDED)

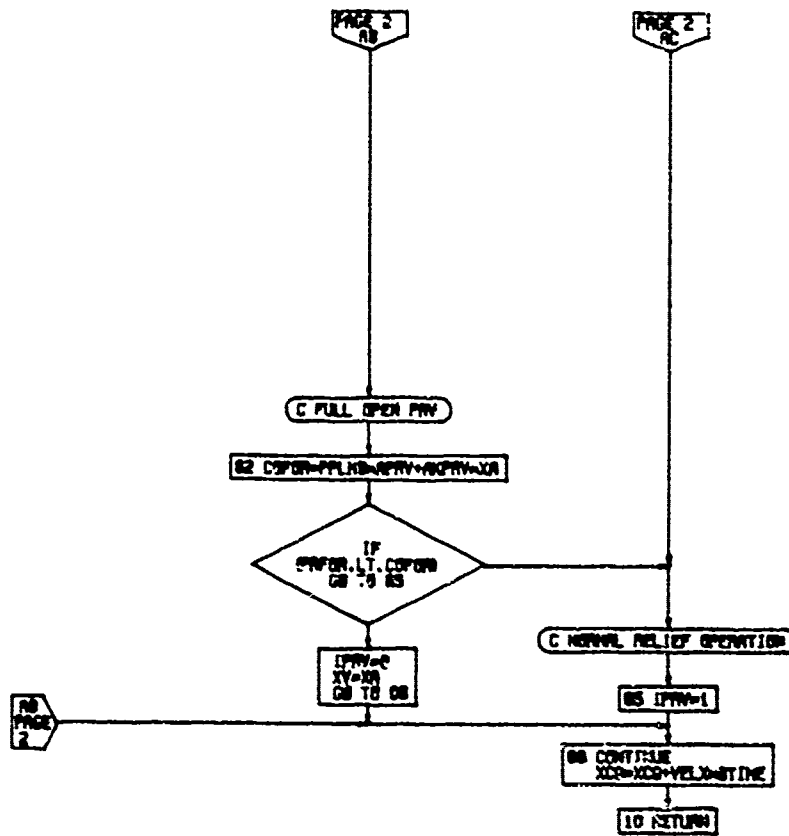

PAGE 3
OUTFM

Table 68: FLOWCHART FOR SUBROUTINE PARAMS

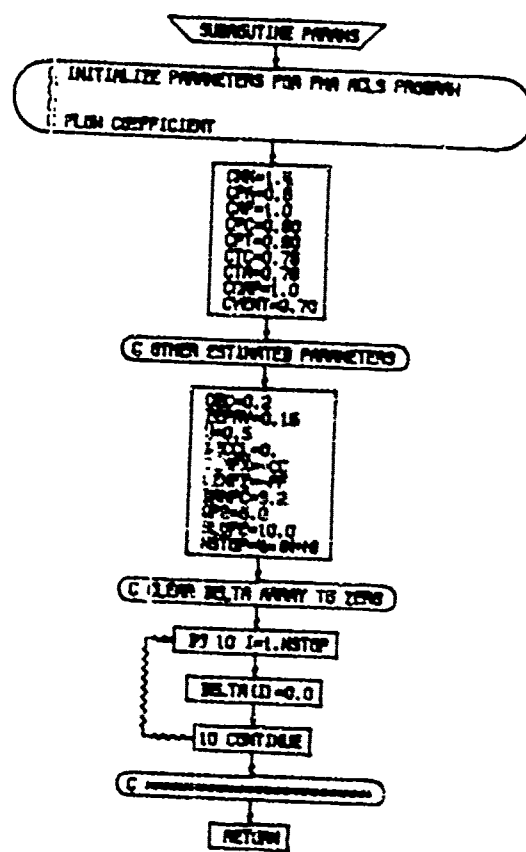

Table 69: FLOWCHART FOR SUBROUTINE PERF

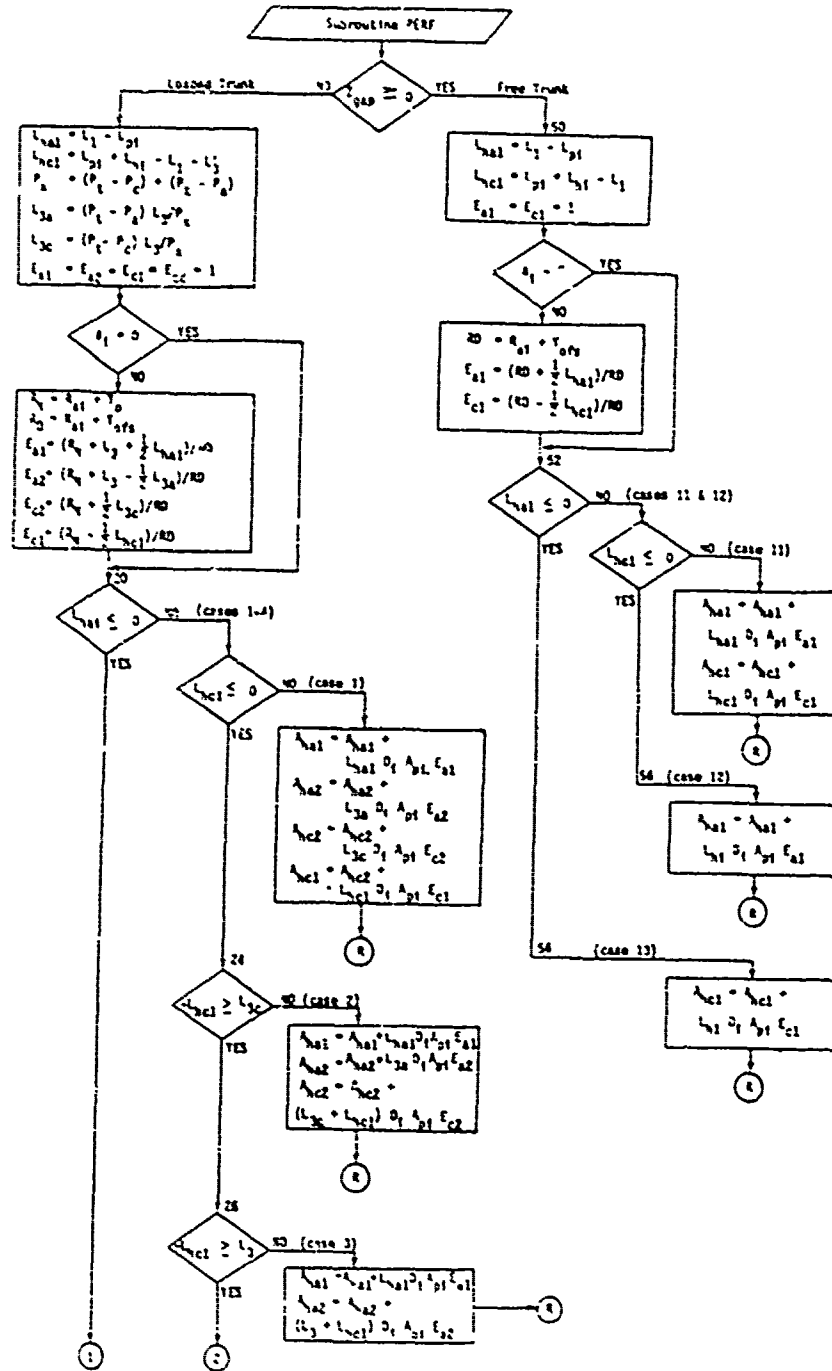

Table 69: FLOWCHART FOR SUBROUTINE PERF (CONCLUDED)

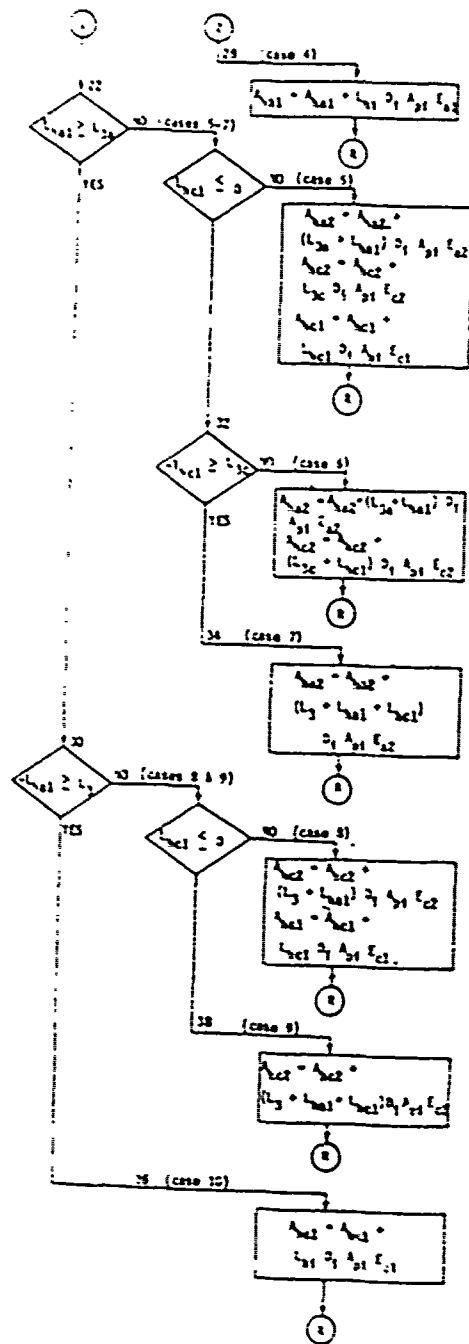

Table 70: FLOWCHART FOR SUBROUTINE PERFB

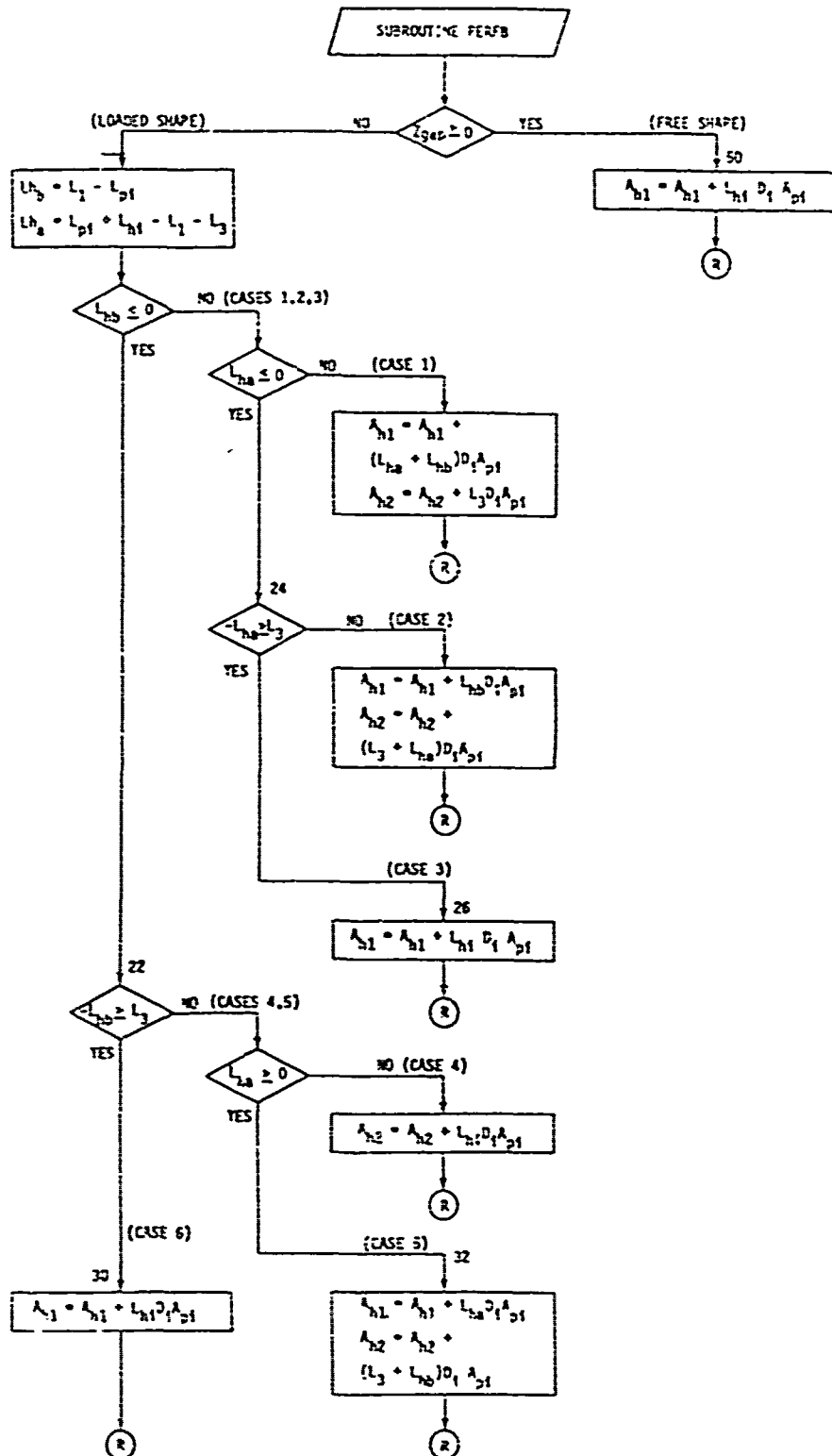

Table 71: FLOWCHART FOR SUBROUTINE PRND

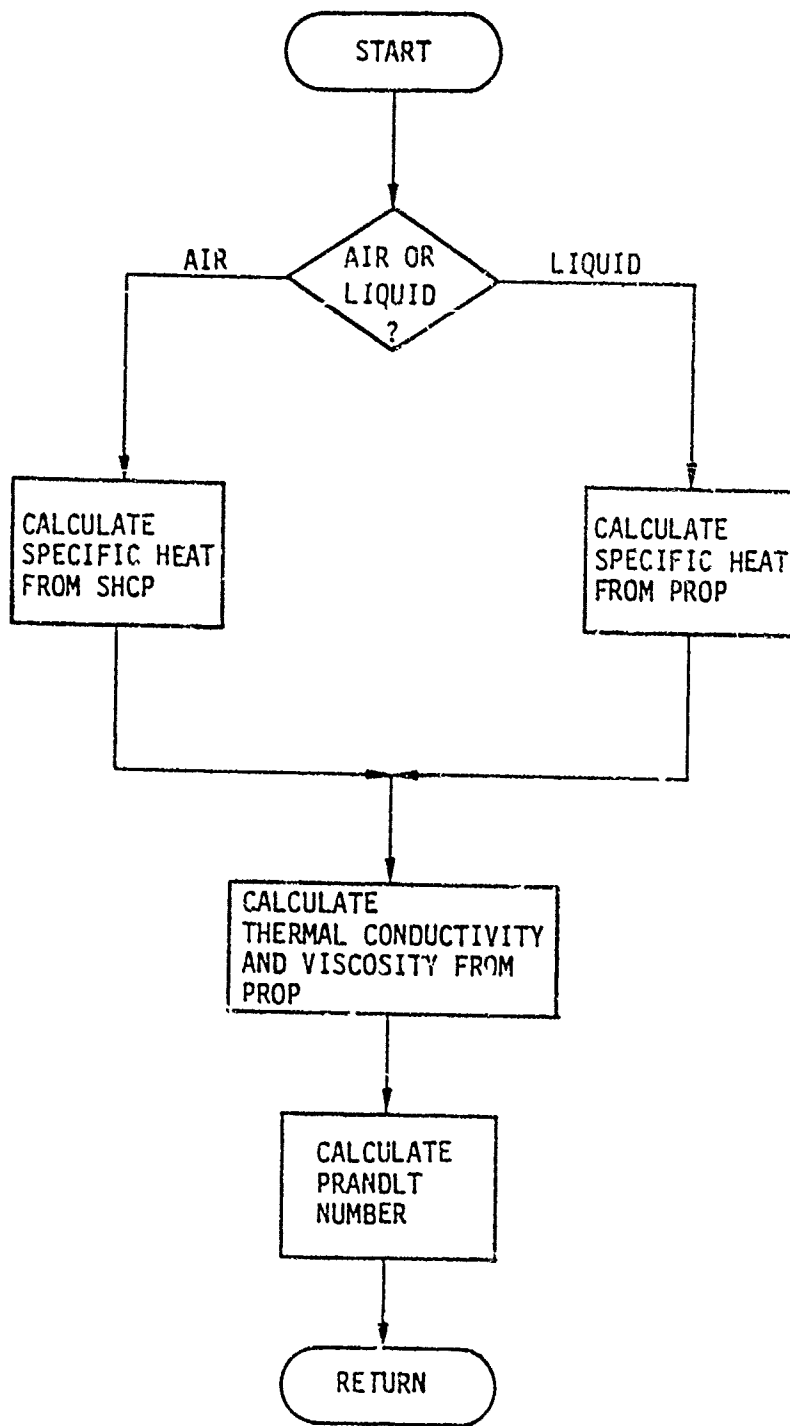

Table 72: FLOWCHART FOR SUBROUTINE PROFILE

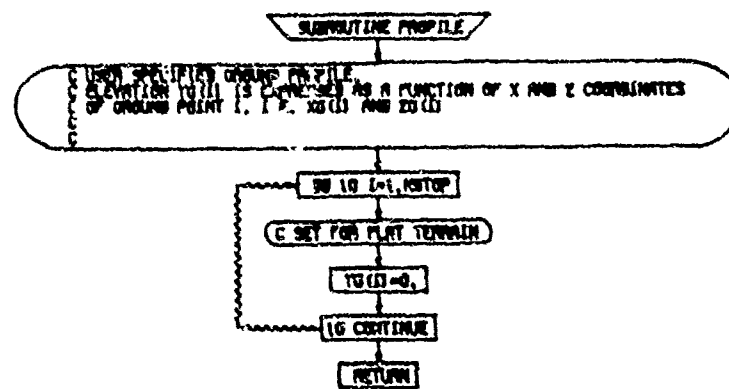

FIG. 1
PROFILE

Table 73: FLOWCHART FOR SUBROUTINE PROP

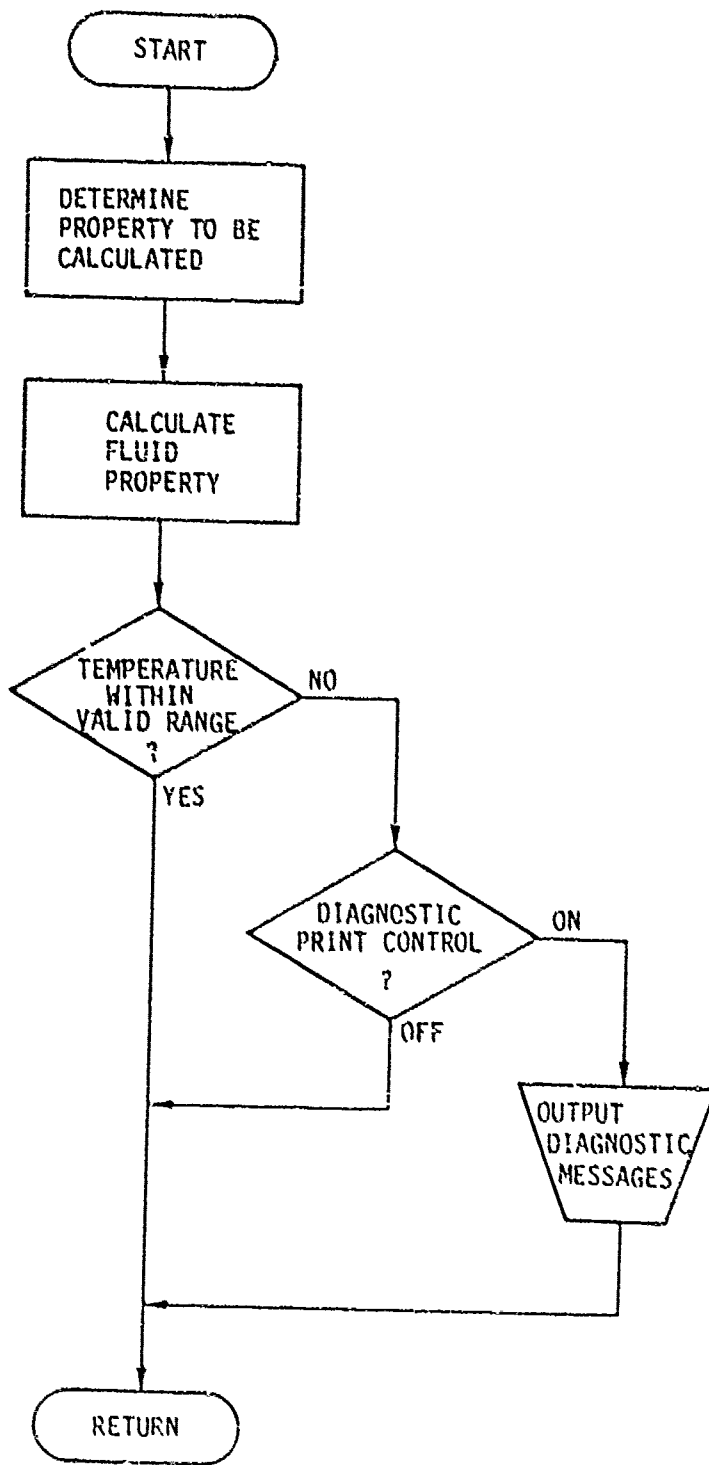
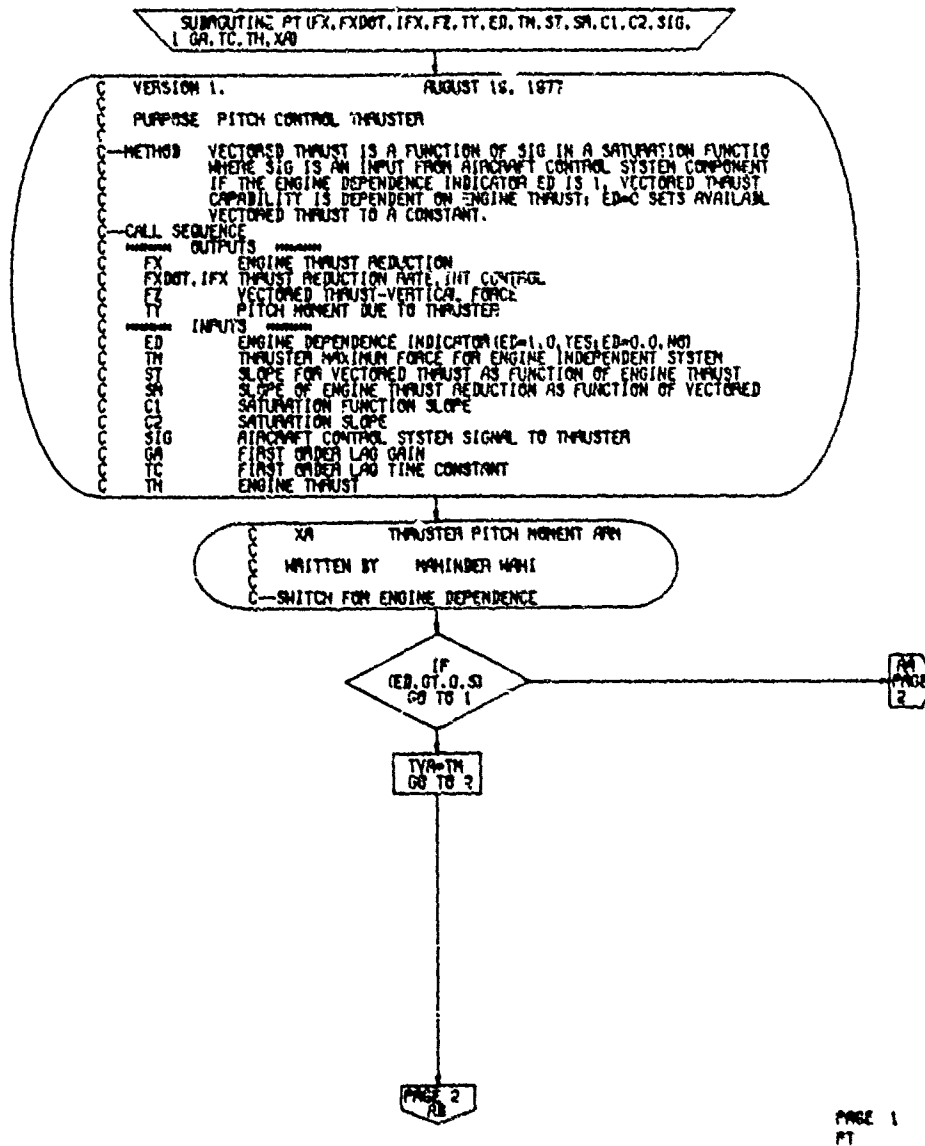
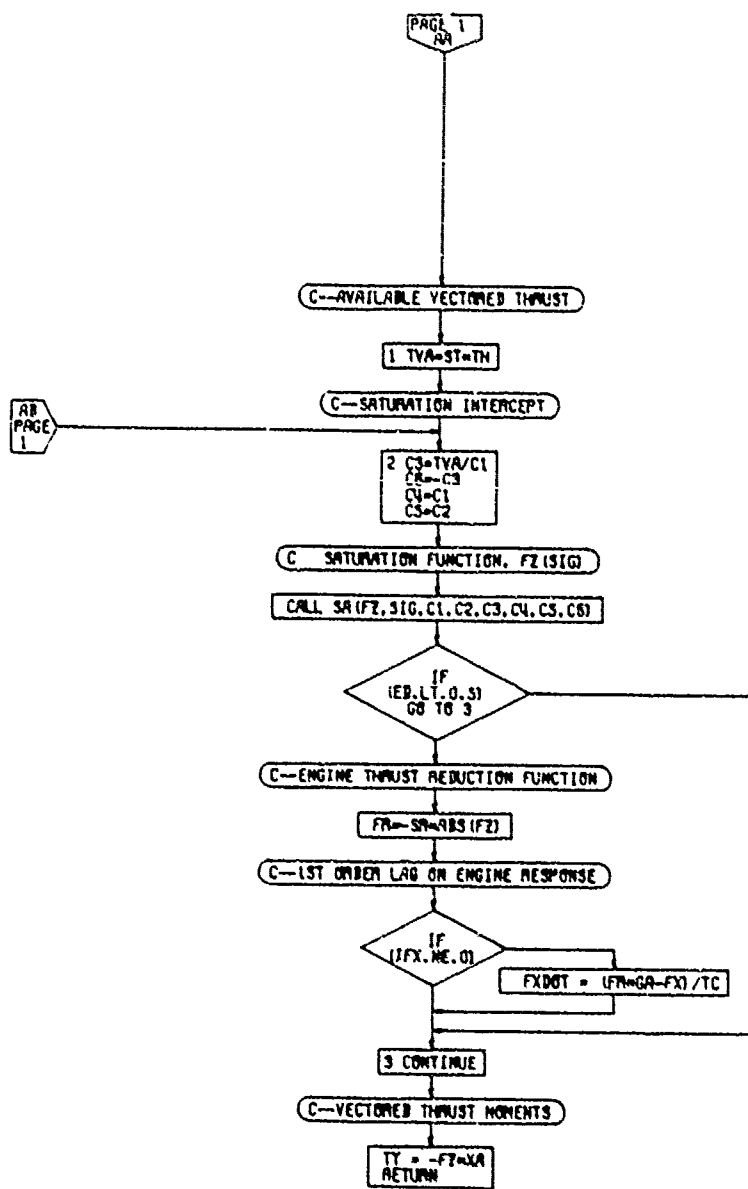

Table 74: FLOWCHART FOR SUBROUTINE PT



PAGE 1
PT

Table 74: FLOWCHART FOR SUBROUTINE PT (CONCLUDED)



PAGE 2
PT

Table 75: FLOWCHART FOR SUBROUTINE RA

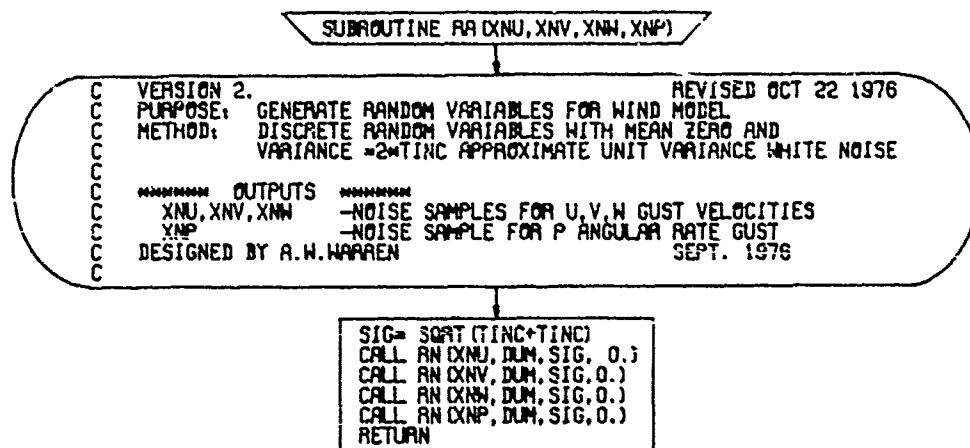

Table 76: FLOWCHART FOR SUBROUTINE RENVX

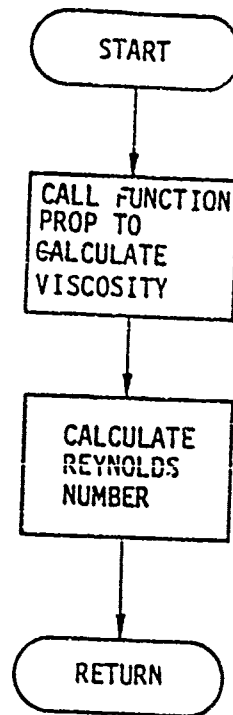

Table 77: FLOWCHART FOR SUBROUTINE RES

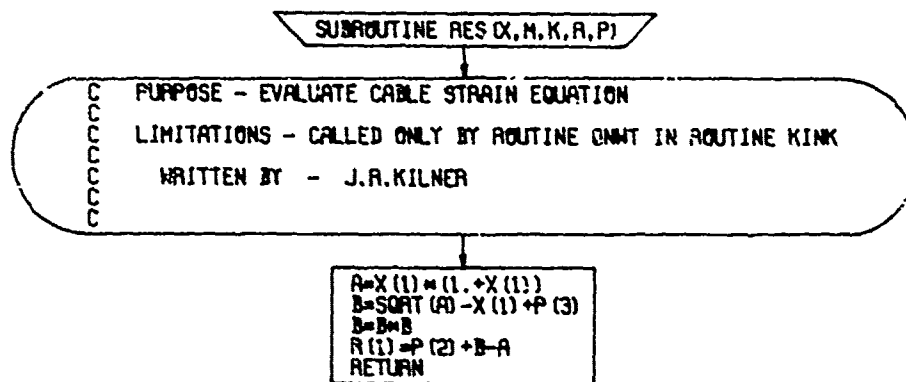
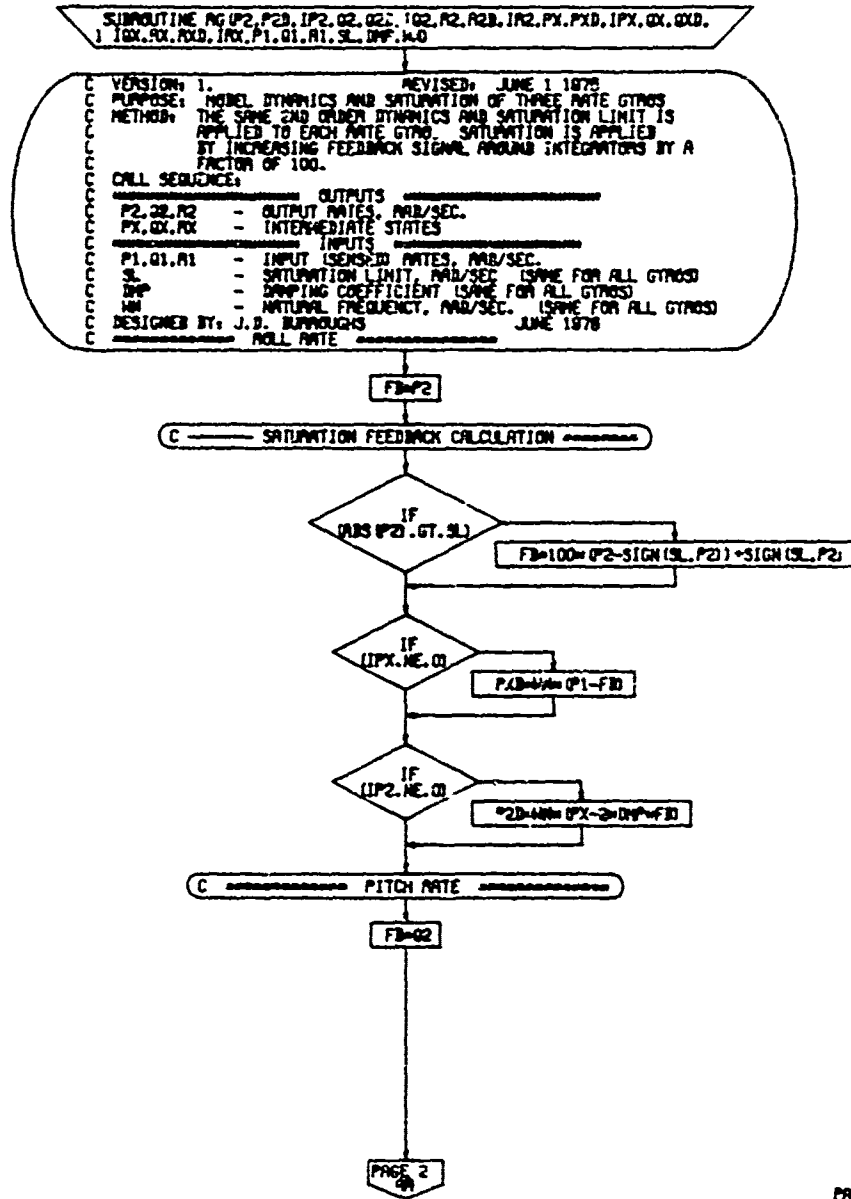

Table 78: FLOWCHART FOR SUBROUTINE RG



PAGE 1
 RG

Table 78: FLOWCHART FOR SUBROUTINE RG (CONCLUDED)

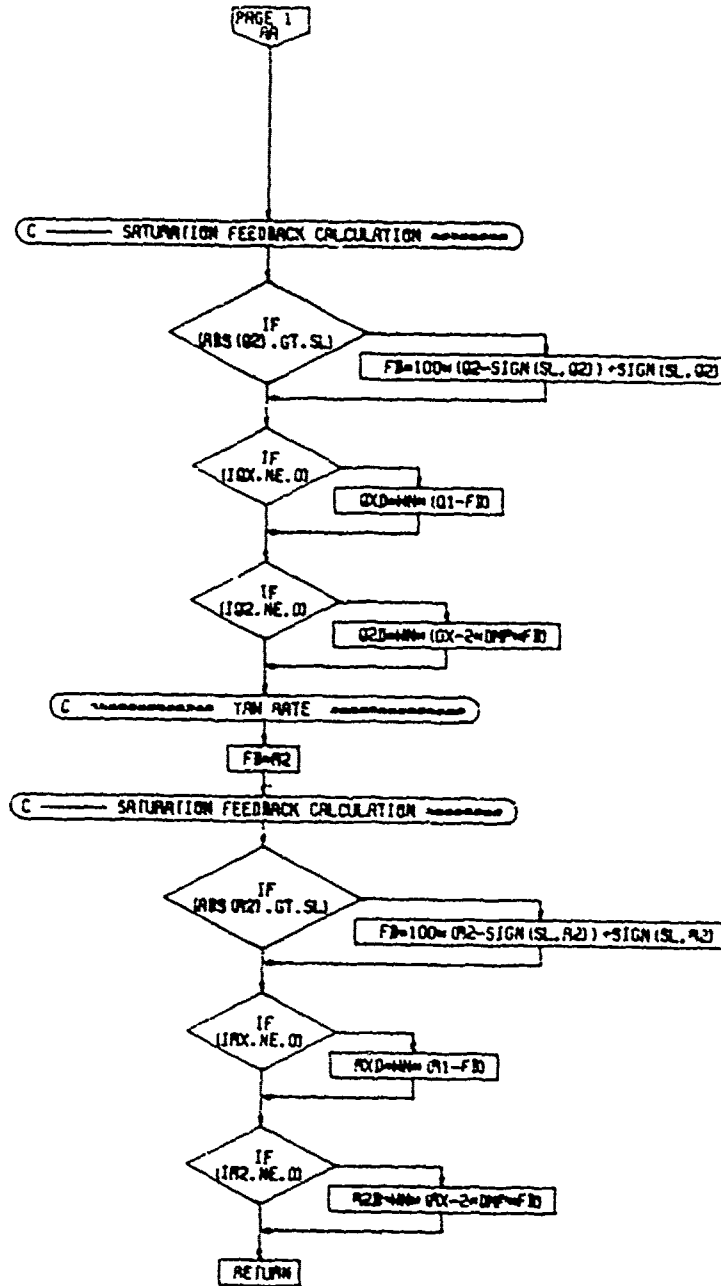

Table 79: FLOWCHART FOR SUBROUTINE RN

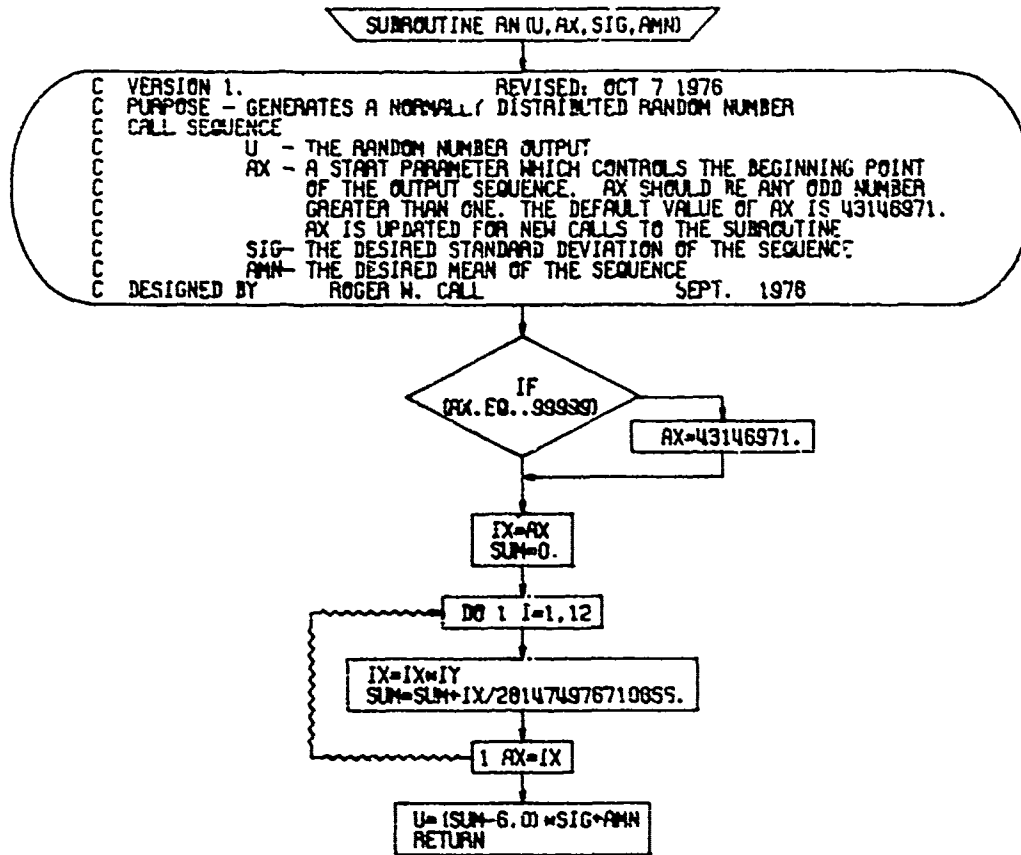

Table 80: FLOWCHART FOR SUBROUTINE ROTATE

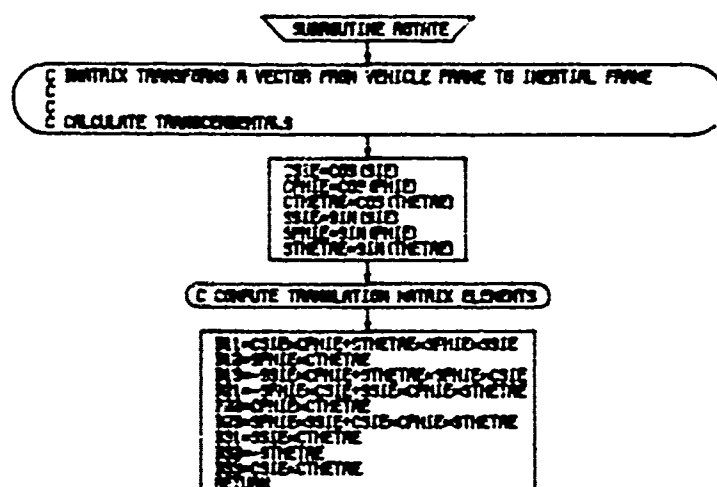
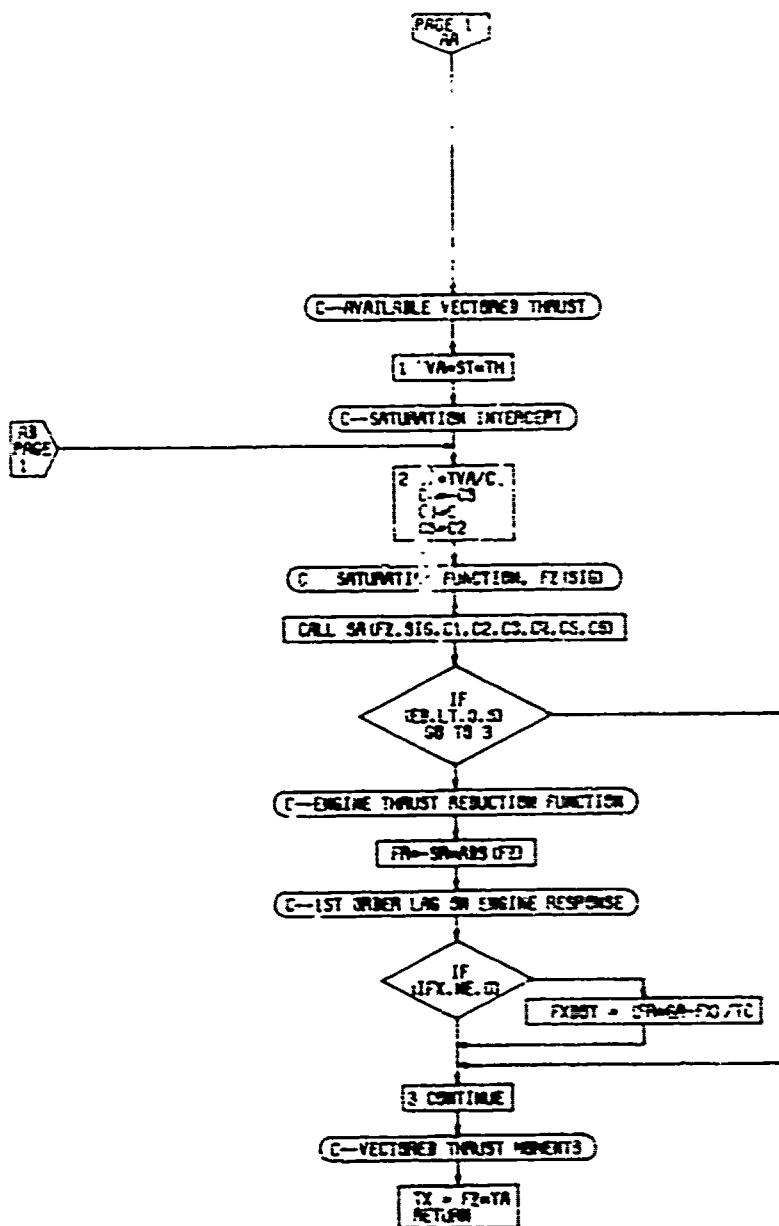

Table 81: FLOWCHART FOR SUBROUTINE RT (CONCLUDED)



RT 2

Table 82: FLOWCHART FOR SUBROUTINE SA

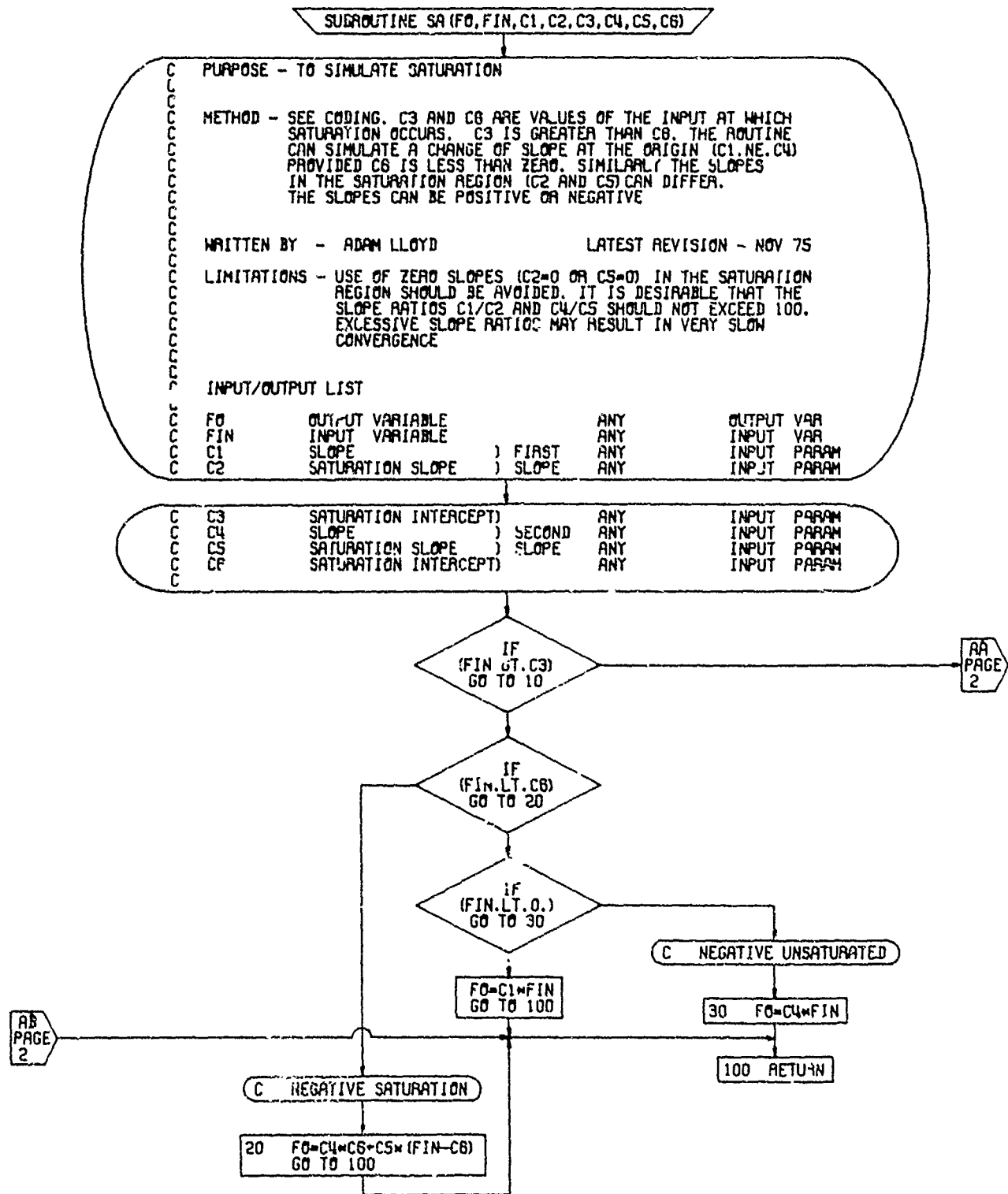

Table 82: FLOWCHART FOR SUBROUTINE SA (CONCLUDED)

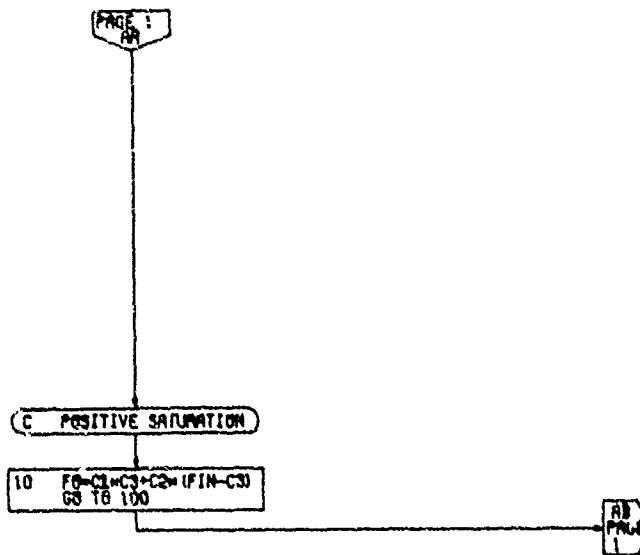

Table 83: FLOWCHART FOR SUBROUTINE SB

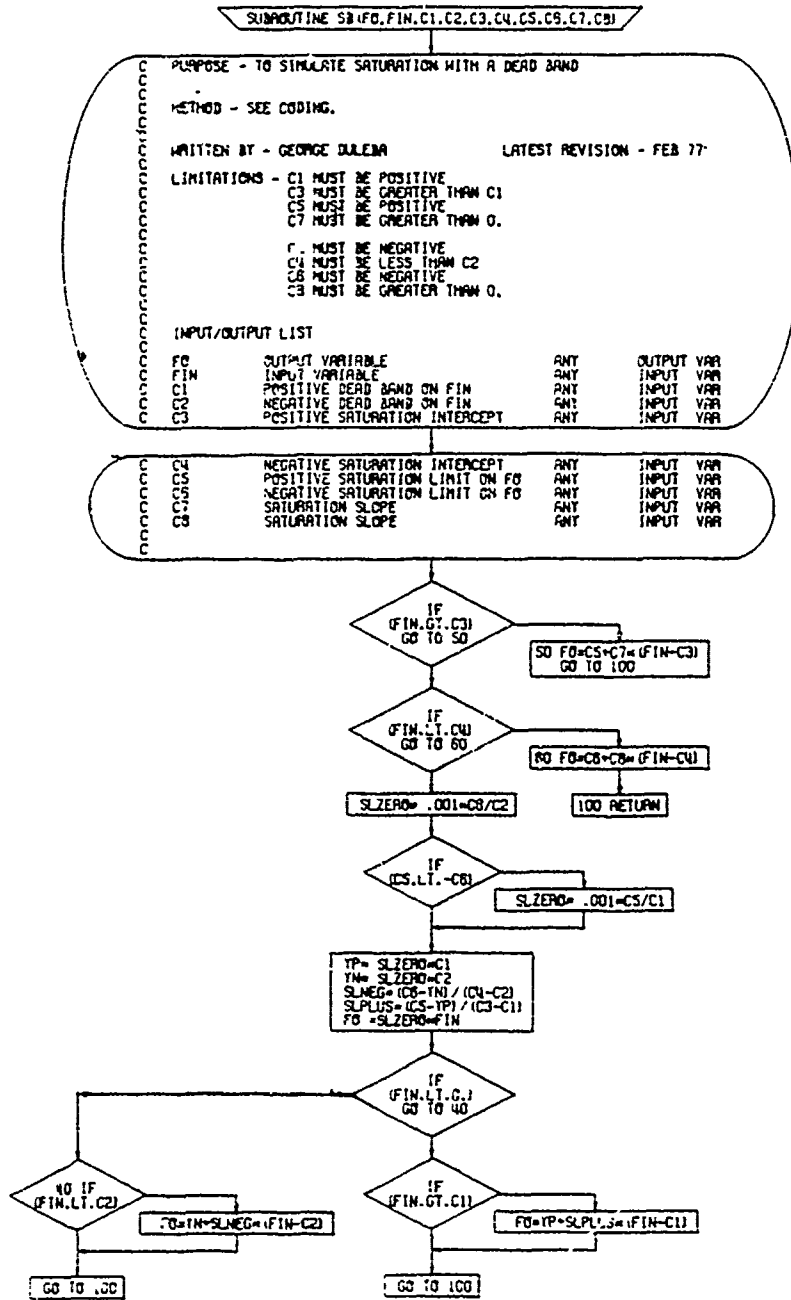

Table 84: FLOWCHART FOR SUBROUTINE SEGMNT

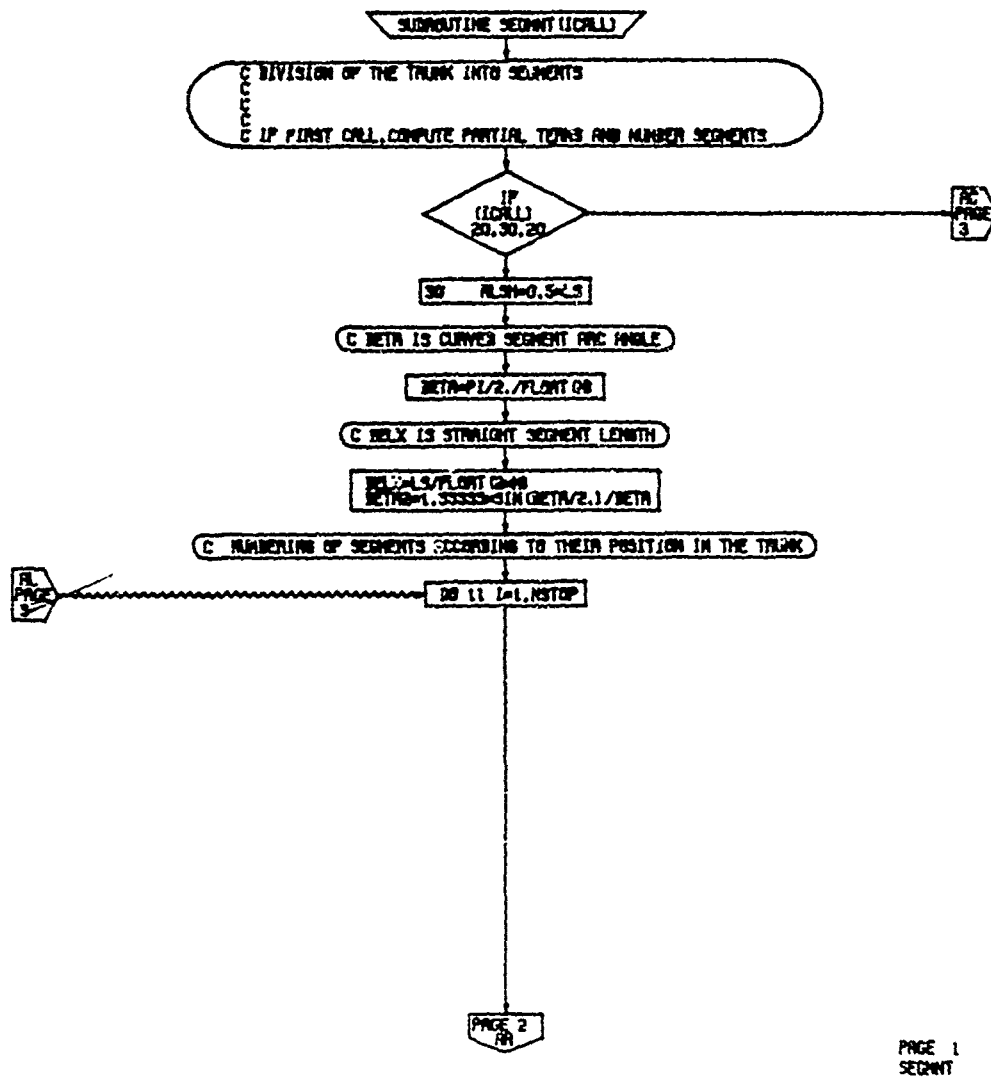
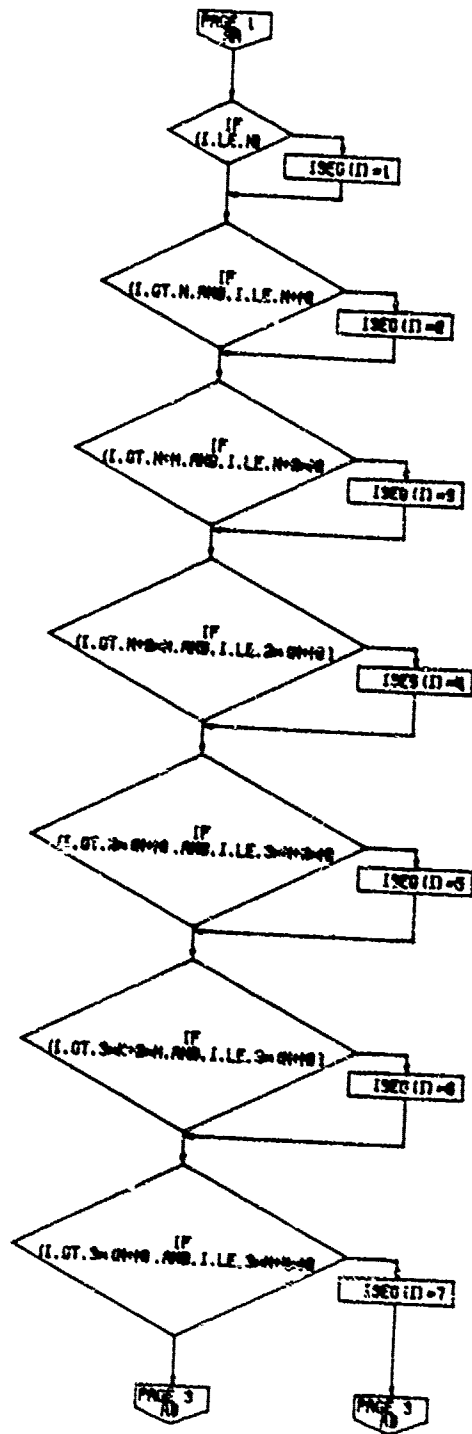

Table 84: FLOWCHART FOR SUBROUTINE SEGMNT (CONTINUED)



PAGE 2
SEGMNT

Table 84: FLOWCHART FOR SUBROUTINE SEGMNT (CONTINUED)

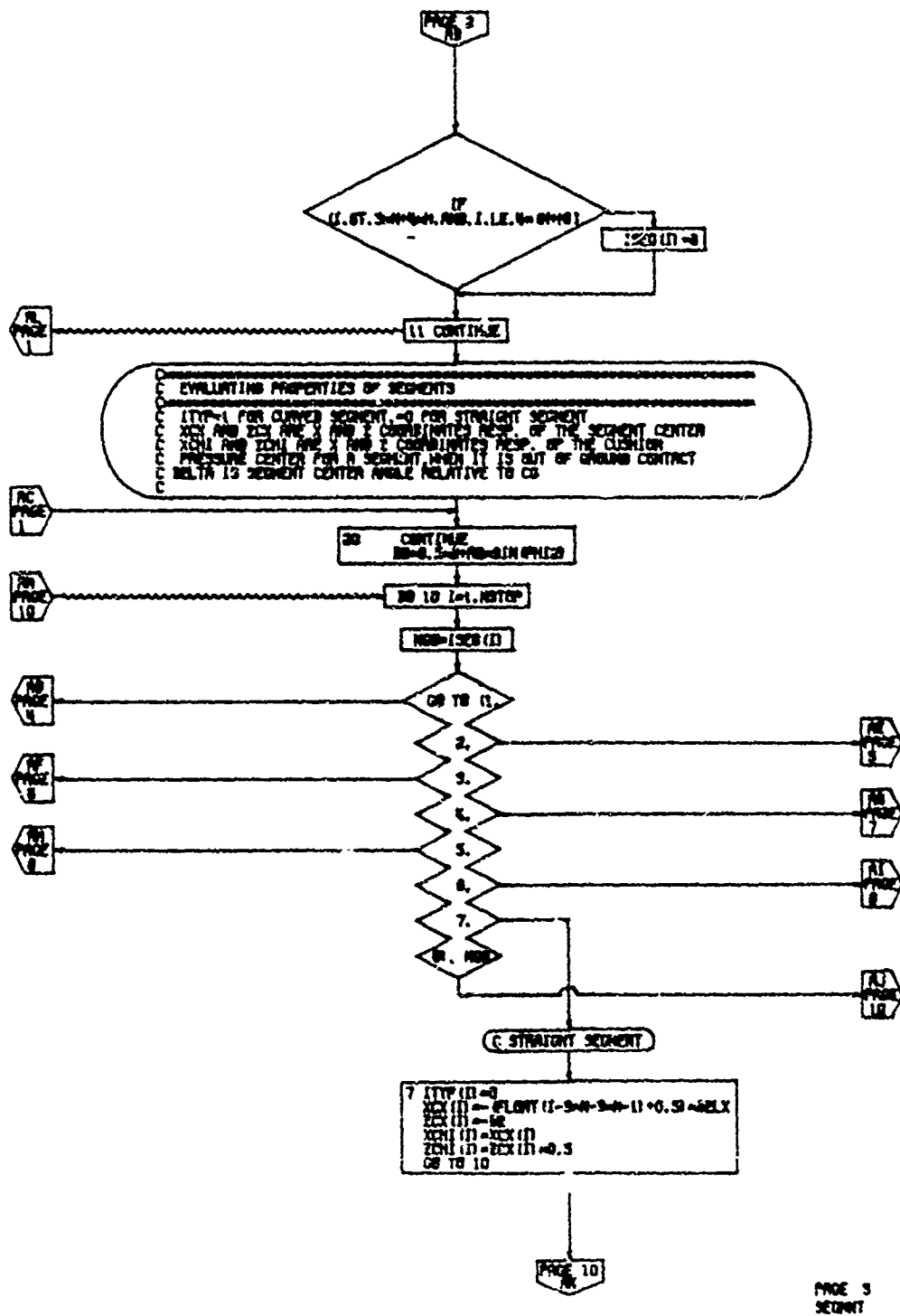
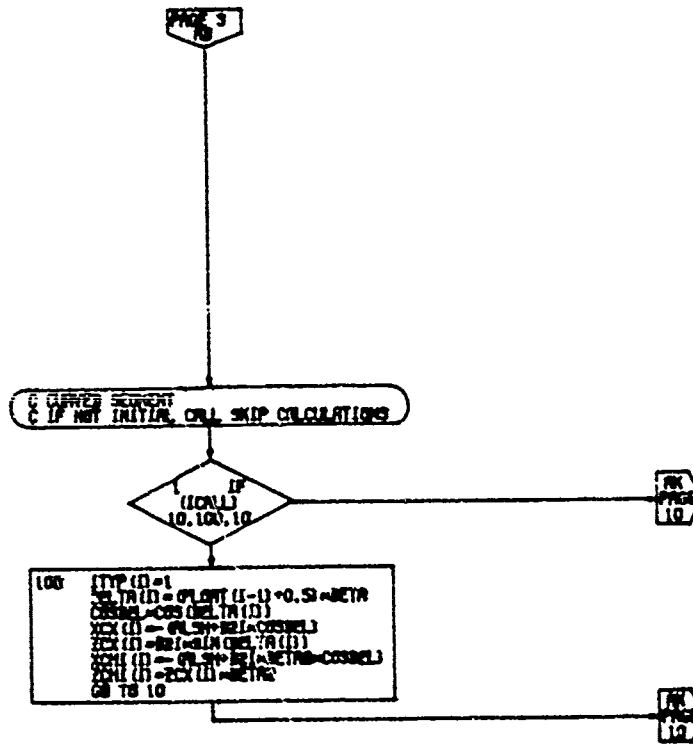
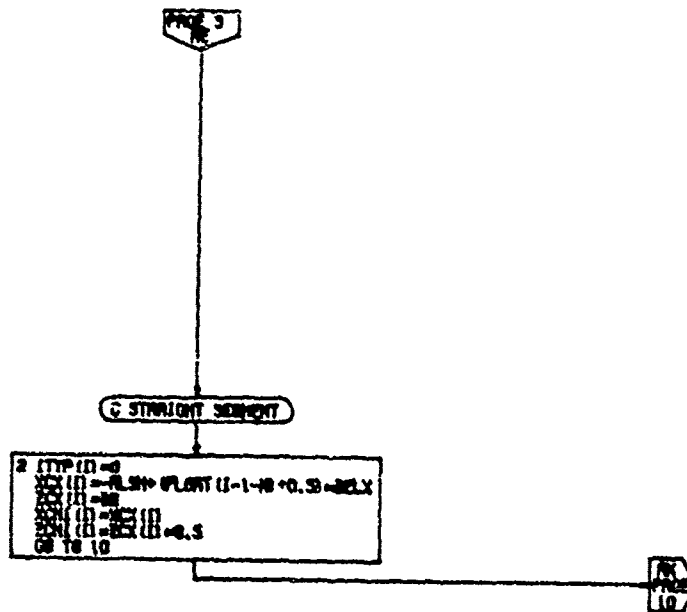

Table 84: FLOWCHART FOR SUBROUTINE SEGMENT (CONTINUED)



PAGE 4
SECRET

Table 84: FLOWCHART FOR SUBROUTINE SEGMENT (CONTINUED)



PAGE 5
SEGMENT

Table 84: FLOWCHART FOR SUBROUTINE SEGMNT (CONTINUED)

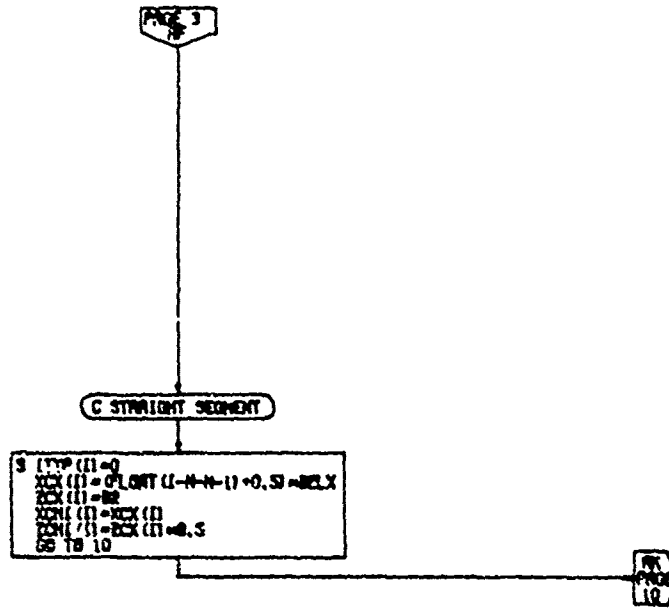

PAGE 8
SECRET

Table 84: FLOWCHART FOR SUBROUTINE SEGMENT (CONTINUED)

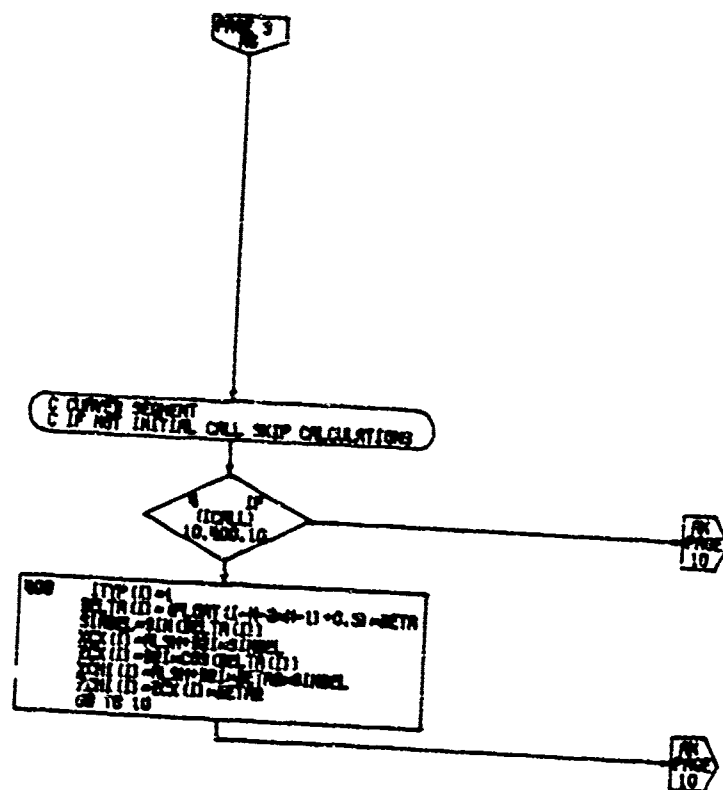

PAGE 7
OF 20

Table 84: FLOWCHART FOR SUBROUTINE SEGMNT (CONTINUED)

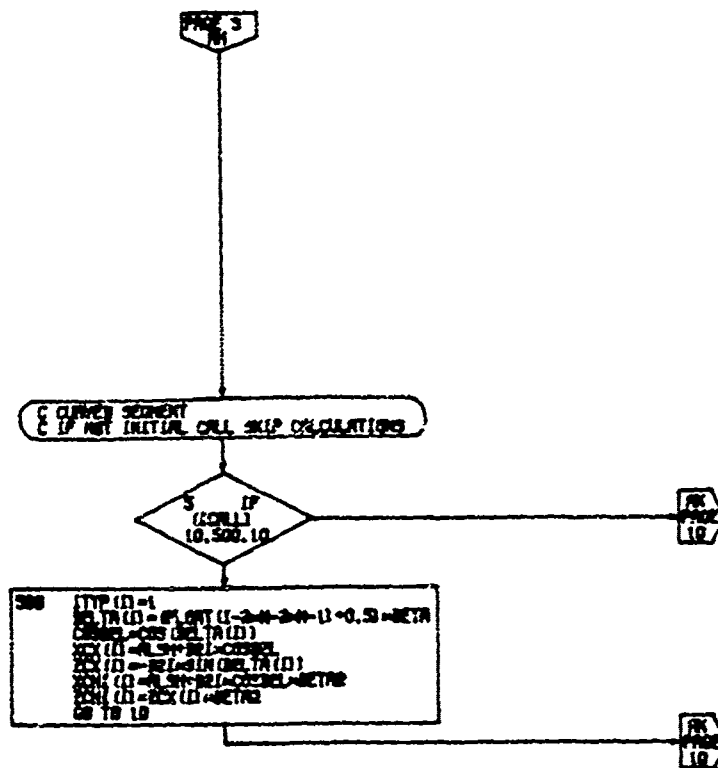

PAGE 2
SEGMNT

Table 84: FLOWCHART FOR SUBROUTINE SEGMENT (CONTINUED)

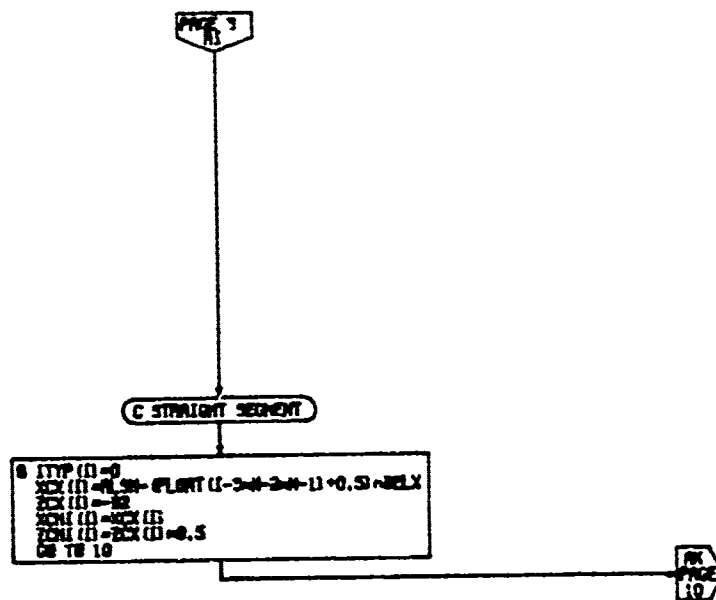

PAGE 9
SEGMENT

Table 84: FLOWCHART FOR SUBROUTINE SEGMENT (CONCLUDED)

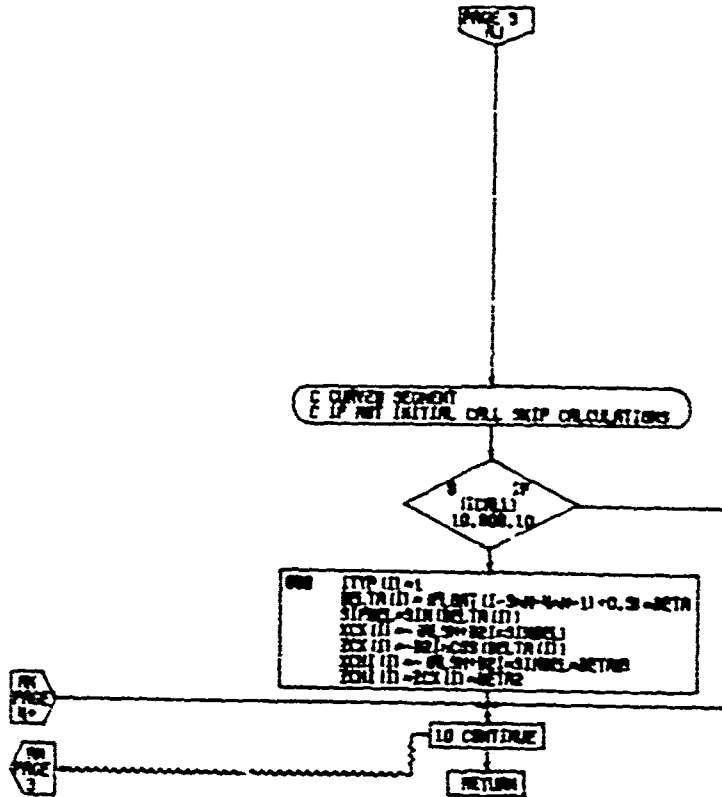

PAGE 10
SECRET

Table 85: FLOWCHART FOR SUBROUTINE SG

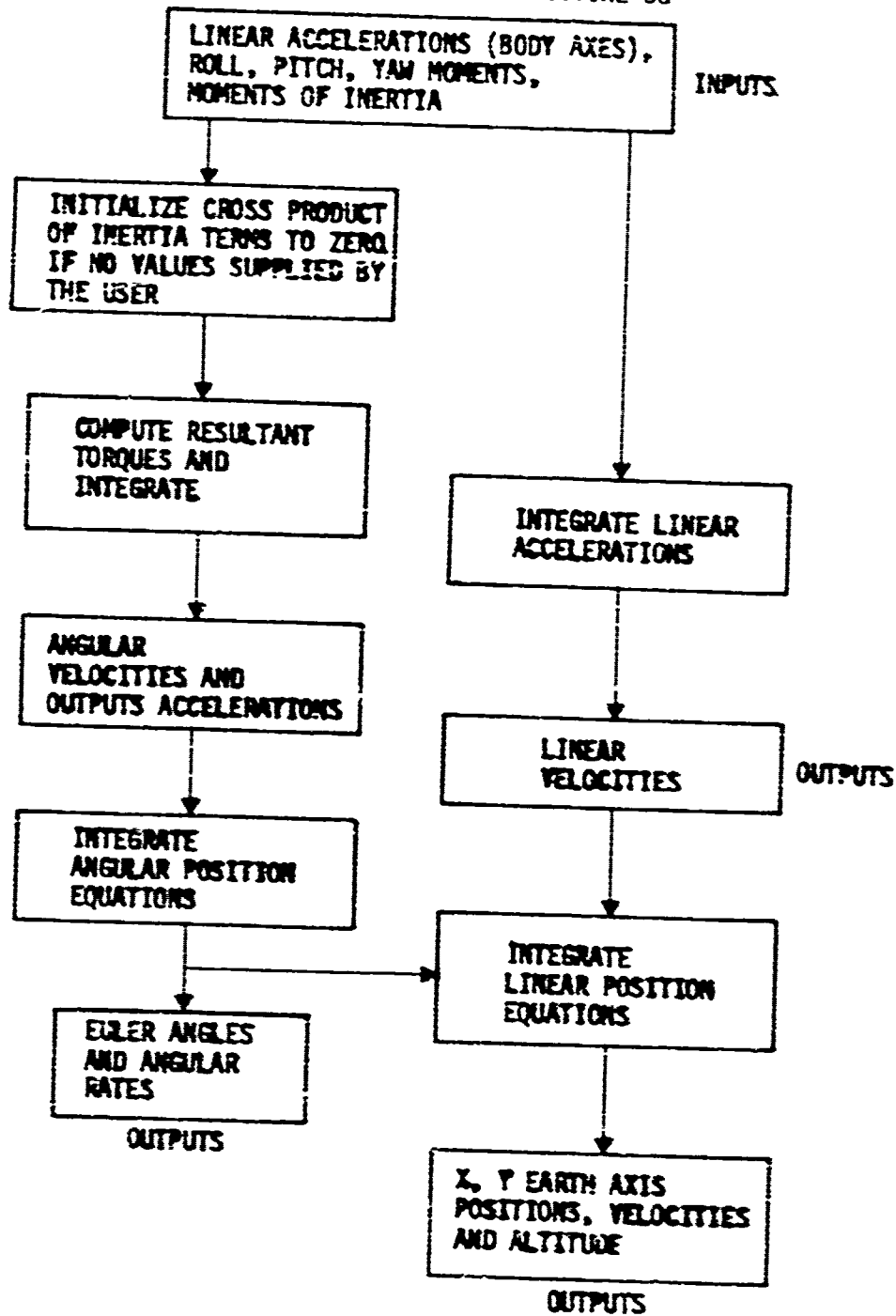
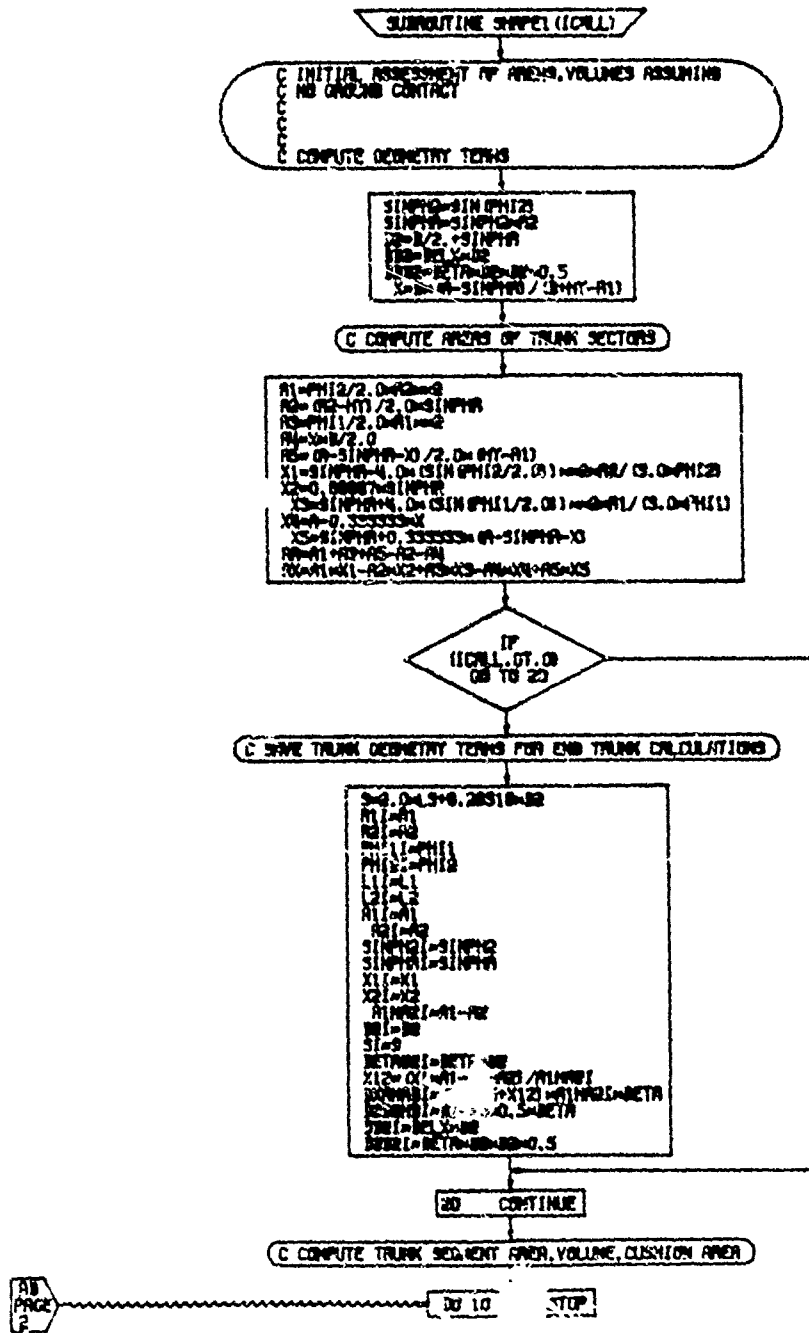
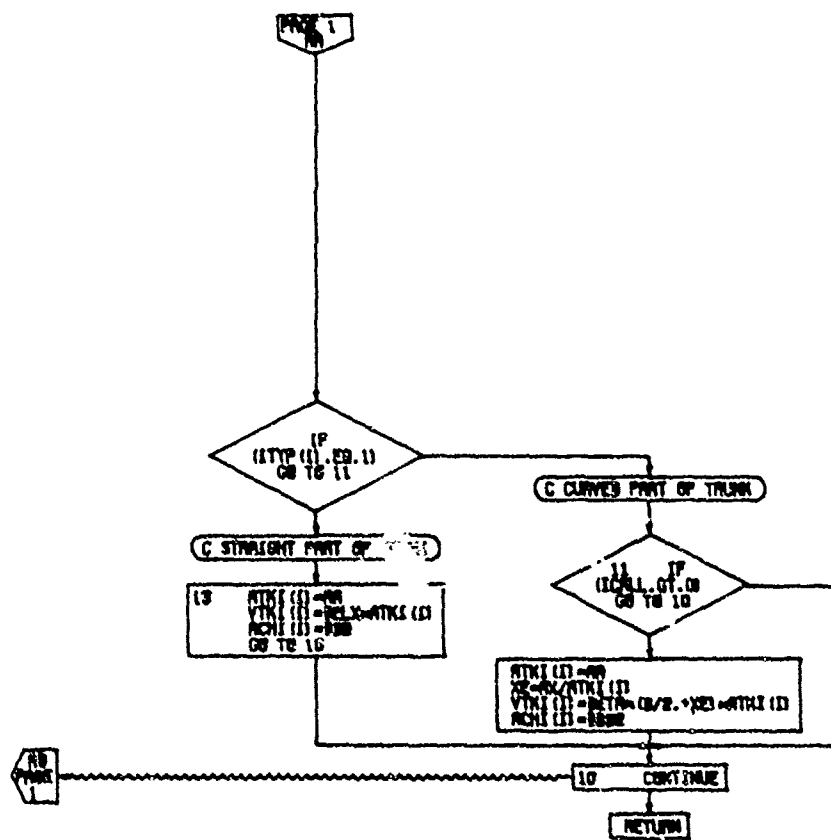

Table 86: FLOWCHART FOR SUBROUTINE SHAPE1



EX-11

Table 86: FLOWCHART FOR SUBROUTINE SHAPE1 (CONCLUDED)



PAGE 2
SHAPE1

Table 87: FLOWCHART FOR SUBROUTINE SHAPE 2

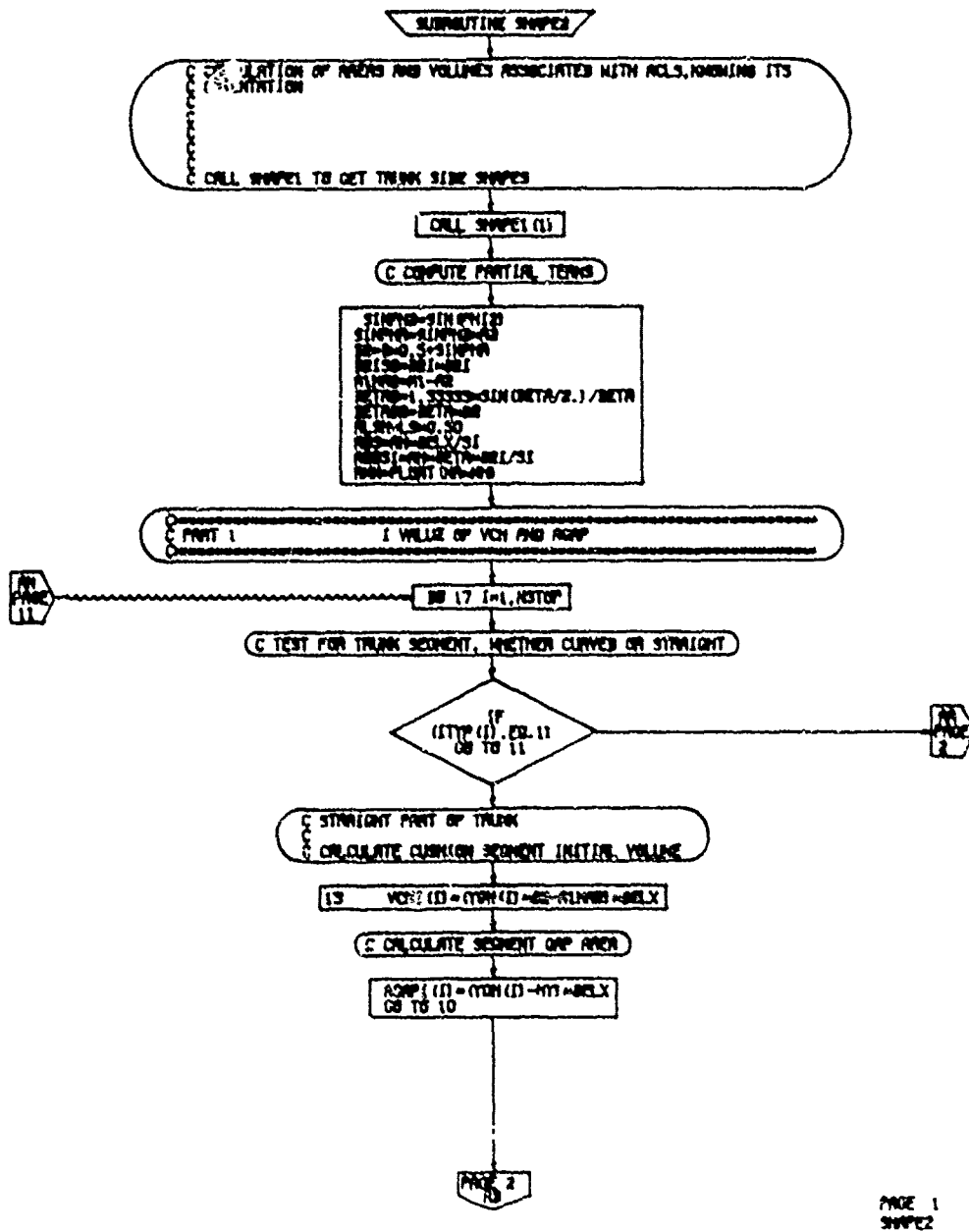

PAGE 1
SHAPE2

Table 87: FLOWCHART FOR SUBROUTINE SHAPE 2 (CONTINUED)

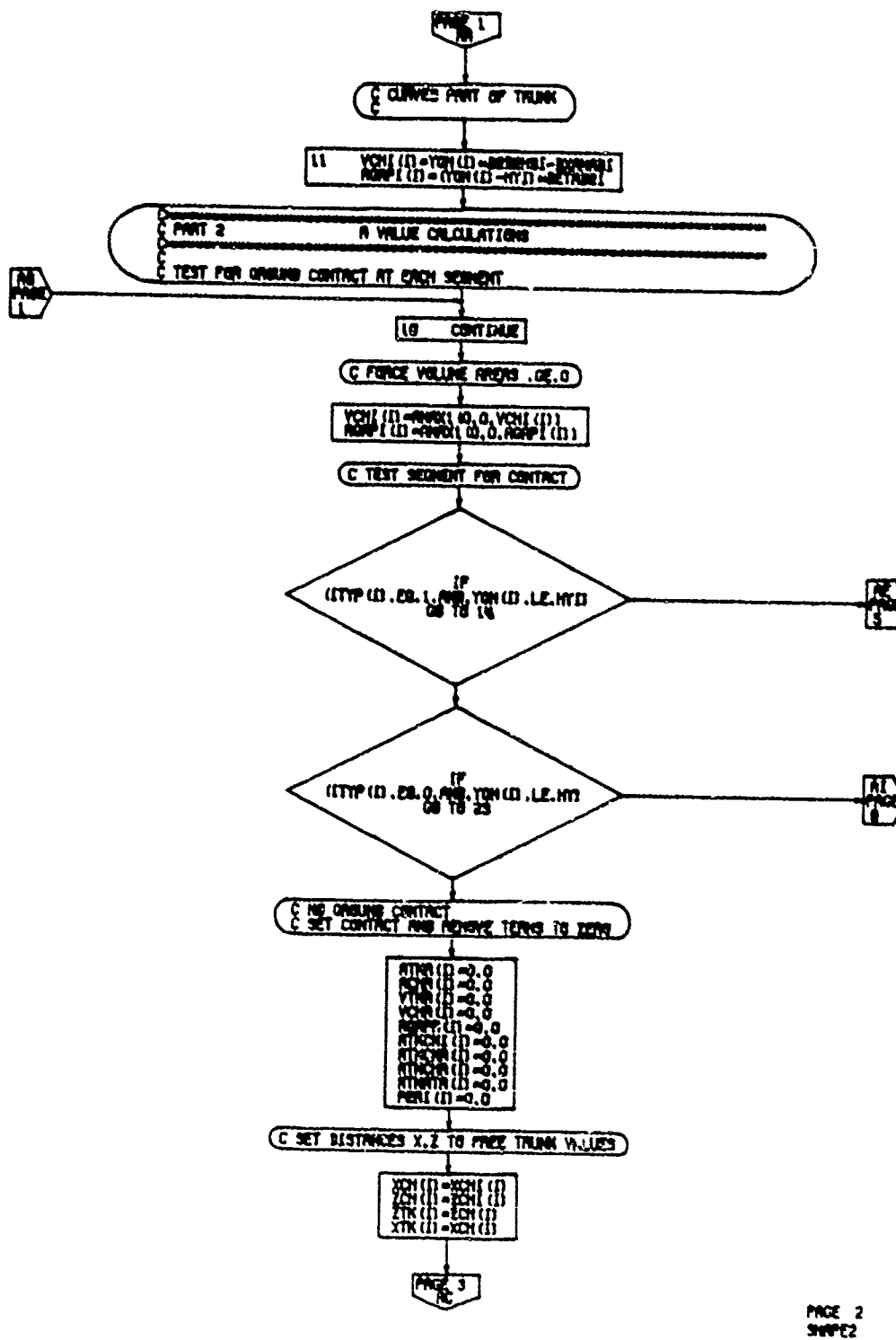
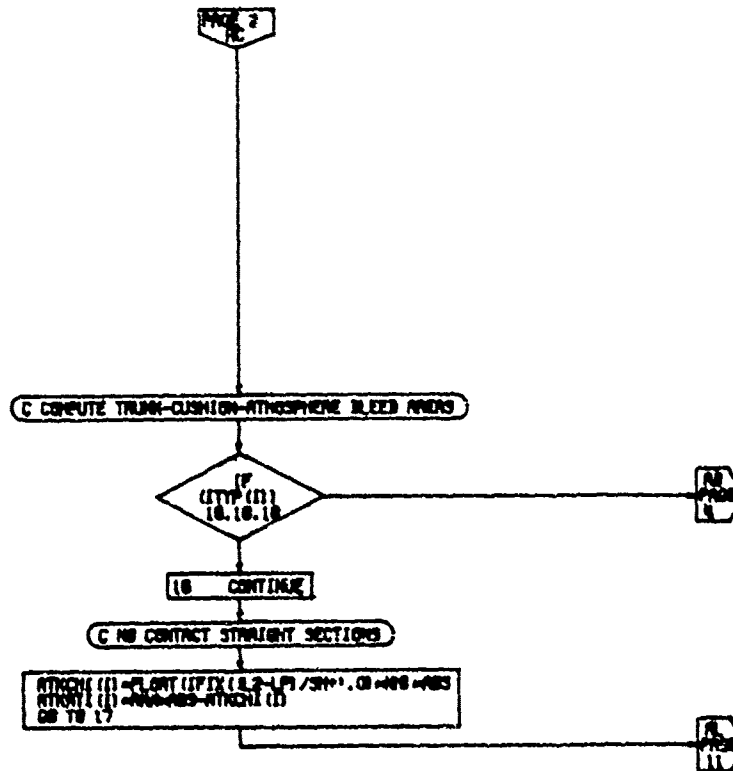

Table 87: FLOWCHART FOR SUBROUTINE SHAPE 2 (CONTINUED)



PAGE 3
SHAP2

Table 87: FLOWCHART FOR SUBROUTINE SHAPE 2 (CONTINUED)

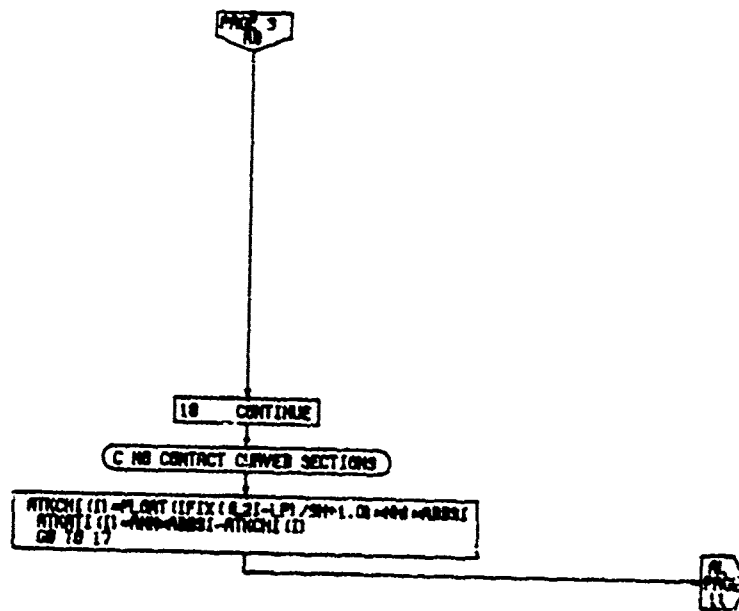
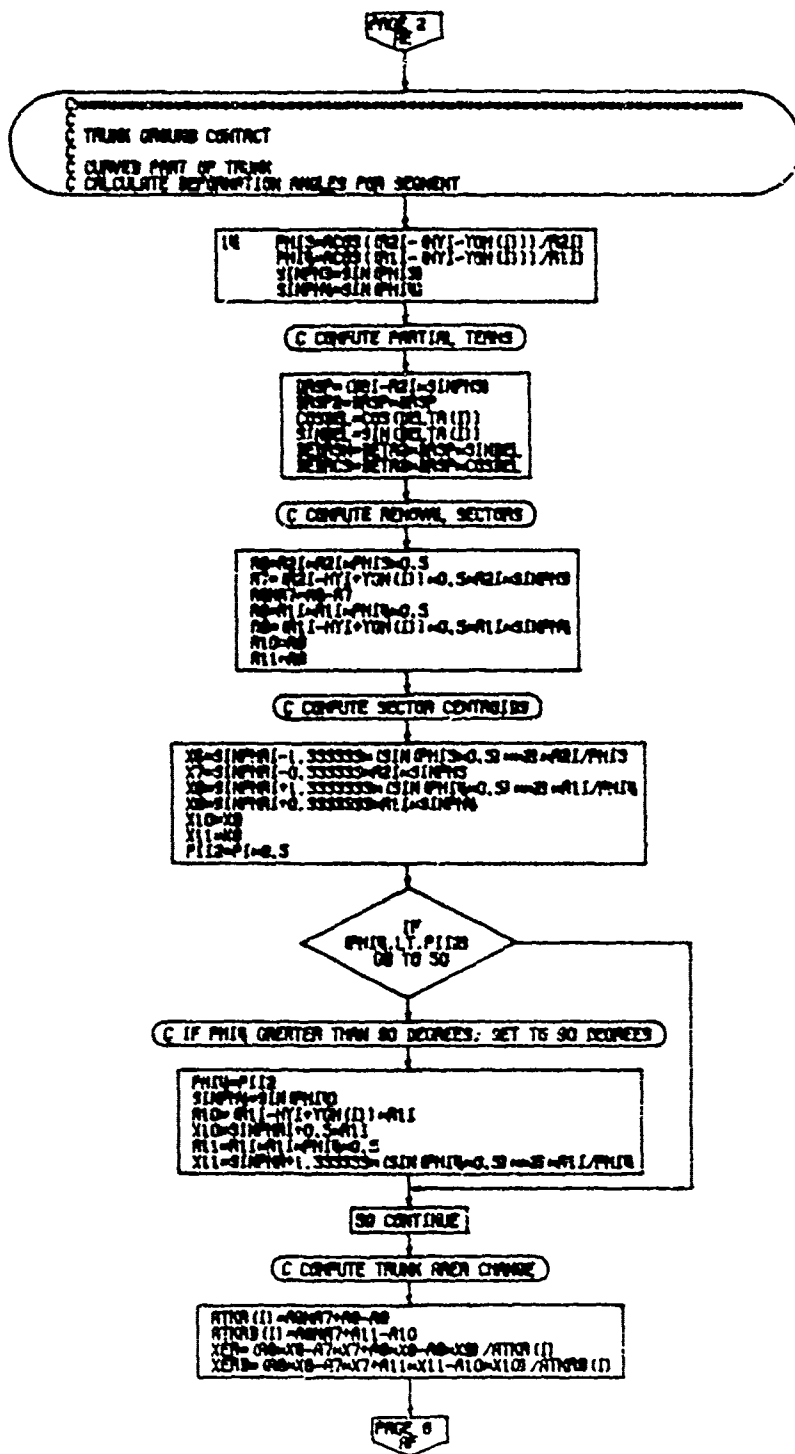

Table 87: FLOWCHART FOR SUBROUTINE SHAPE 2 (CONTINUED)



PAGE 5
 SHAPE2

Table 87: FLOWCHART FOR SUBROUTINE SHAPE 2 (CONTINUED)

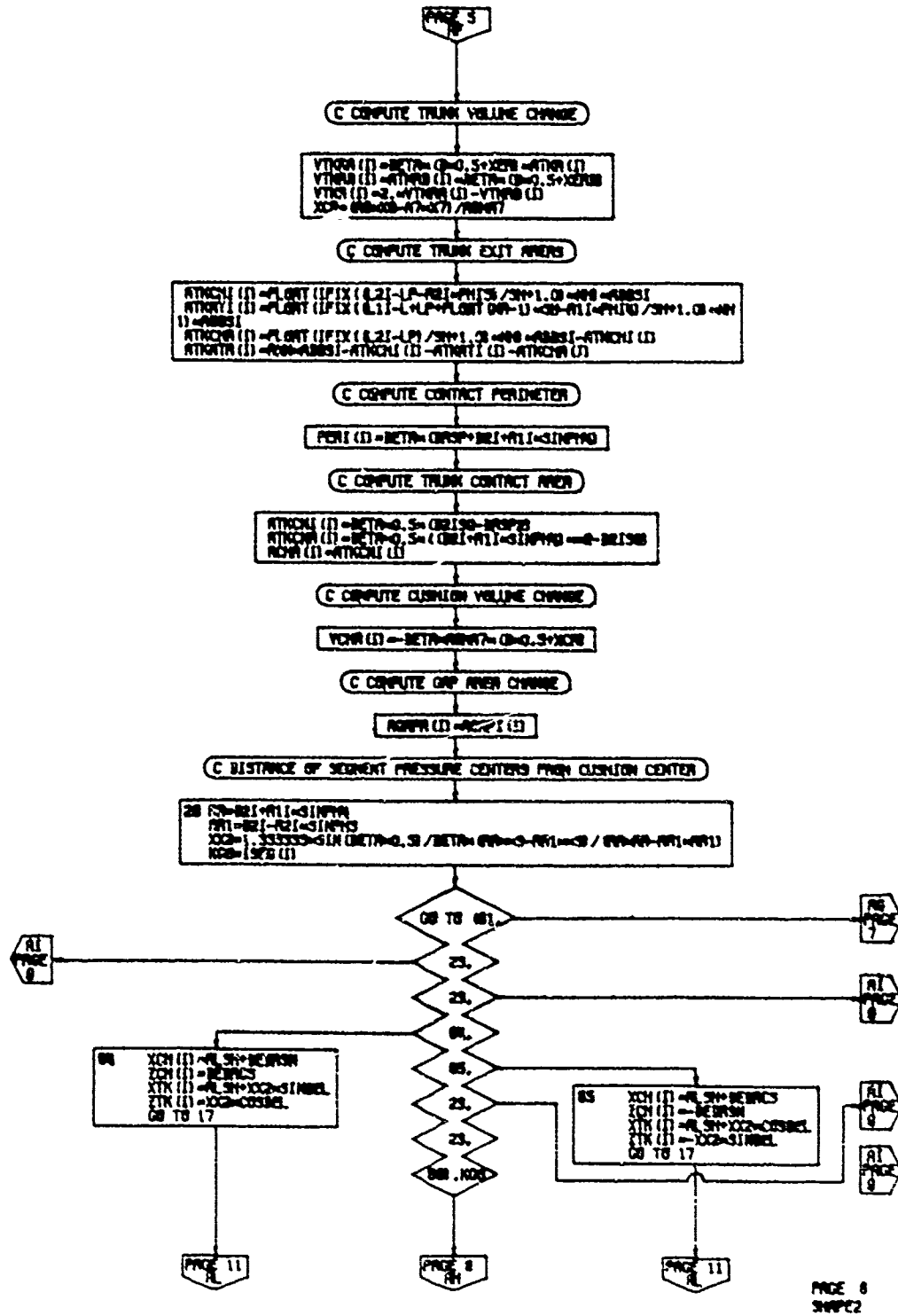
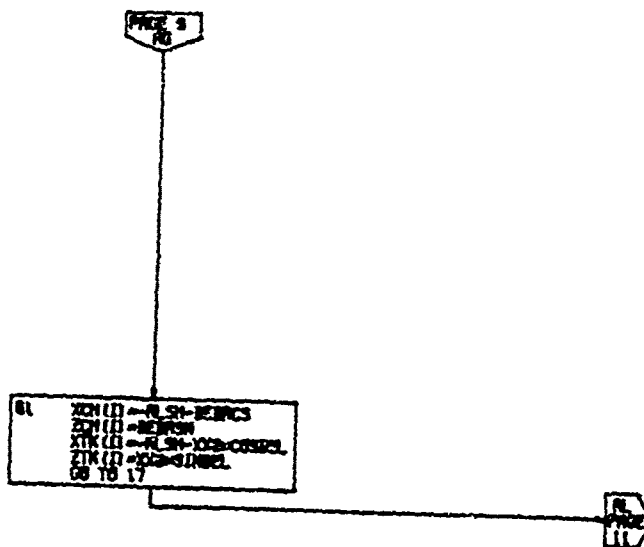
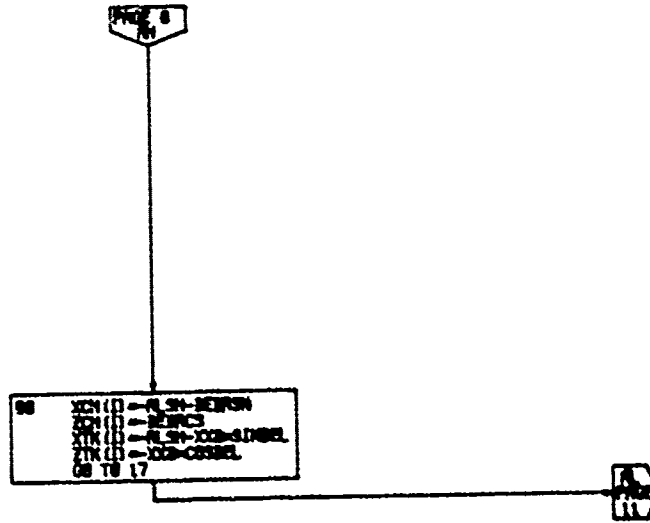

Table 87: FLOWCHART FOR SUBROUTINE SHAPE 2 (CONTINUED)



PAGE 7
SHAPE2

Table 87: FLOWCHART FOR SUBROUTINE SHAPE 2 (CONTINUED)



PAGE 8
SHPC2

Table 87: FLOWCHART FOR SUBROUTINE SHAPE 2 (CONTINUED)

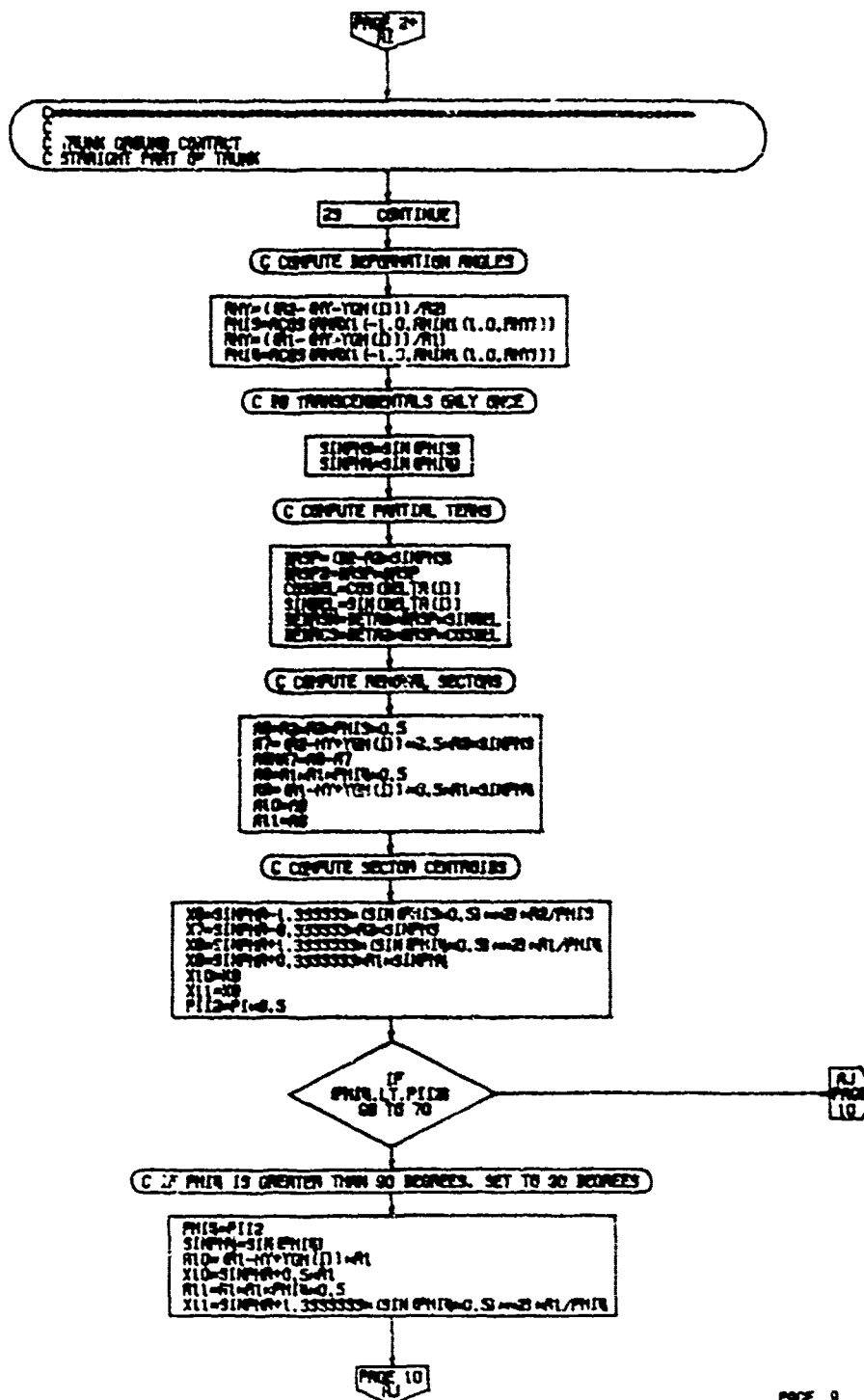

PAGE 9
SHAPE2

Table 87: FLOWCHART FOR SUBROUTINE SHAPE 2 (CONTINUED)

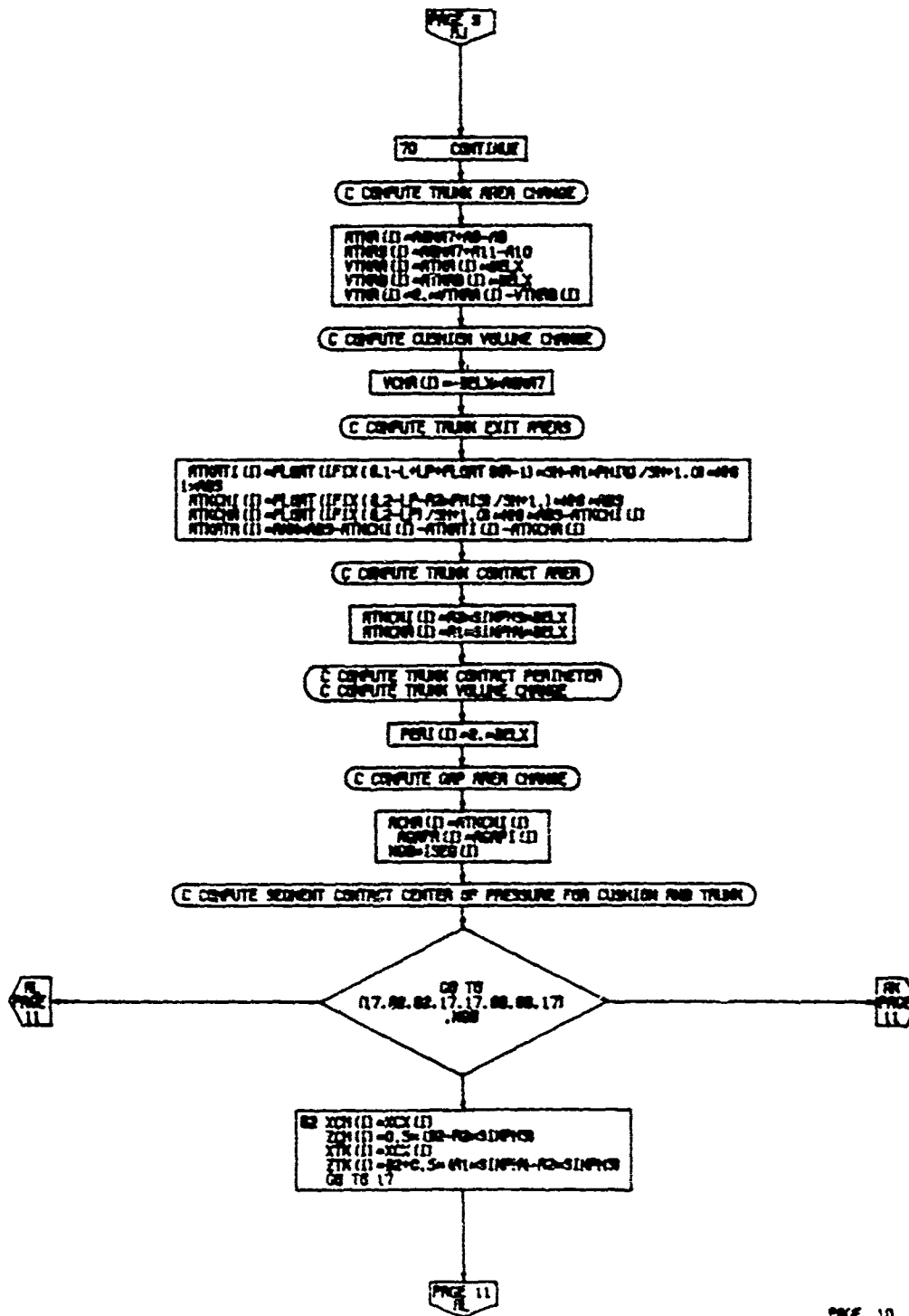

PAGE 10
SHAPE2

Table 87: FLOWCHART FOR SUBROUTINE SHAPE 2 (CONTINUED)

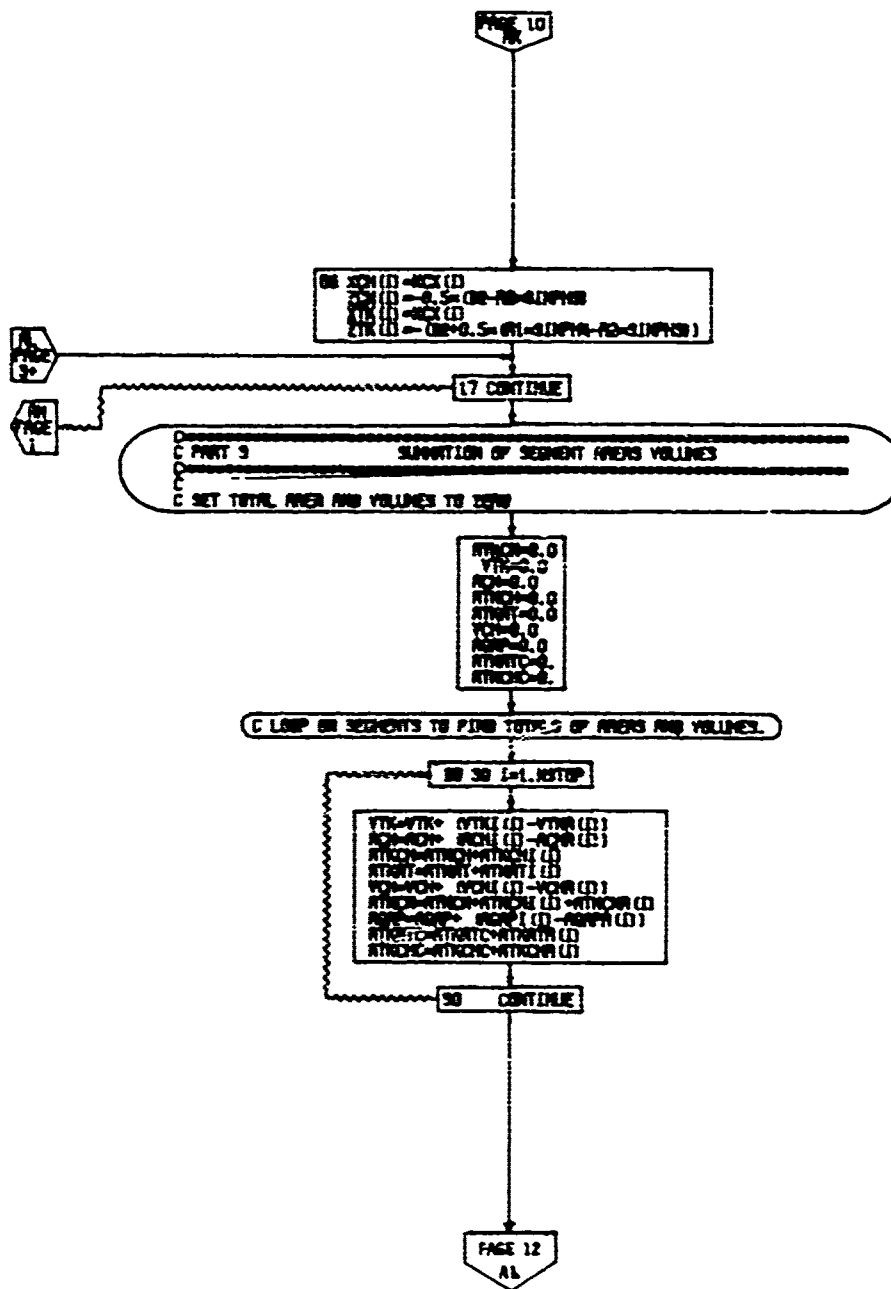

PAGE 11
SHAPE2

Table 87: FLOWCHART FOR SUBROUTINE SHAPE 2 (CONCLUDED;

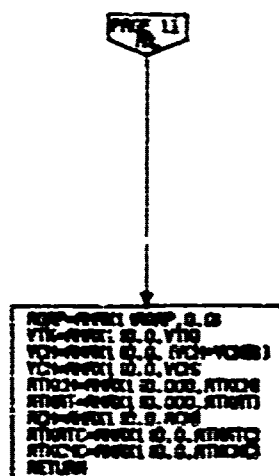

PAGE 12
SHAPE2

Table 88 FLOWCHART FOR SUBROUTINE SHCP

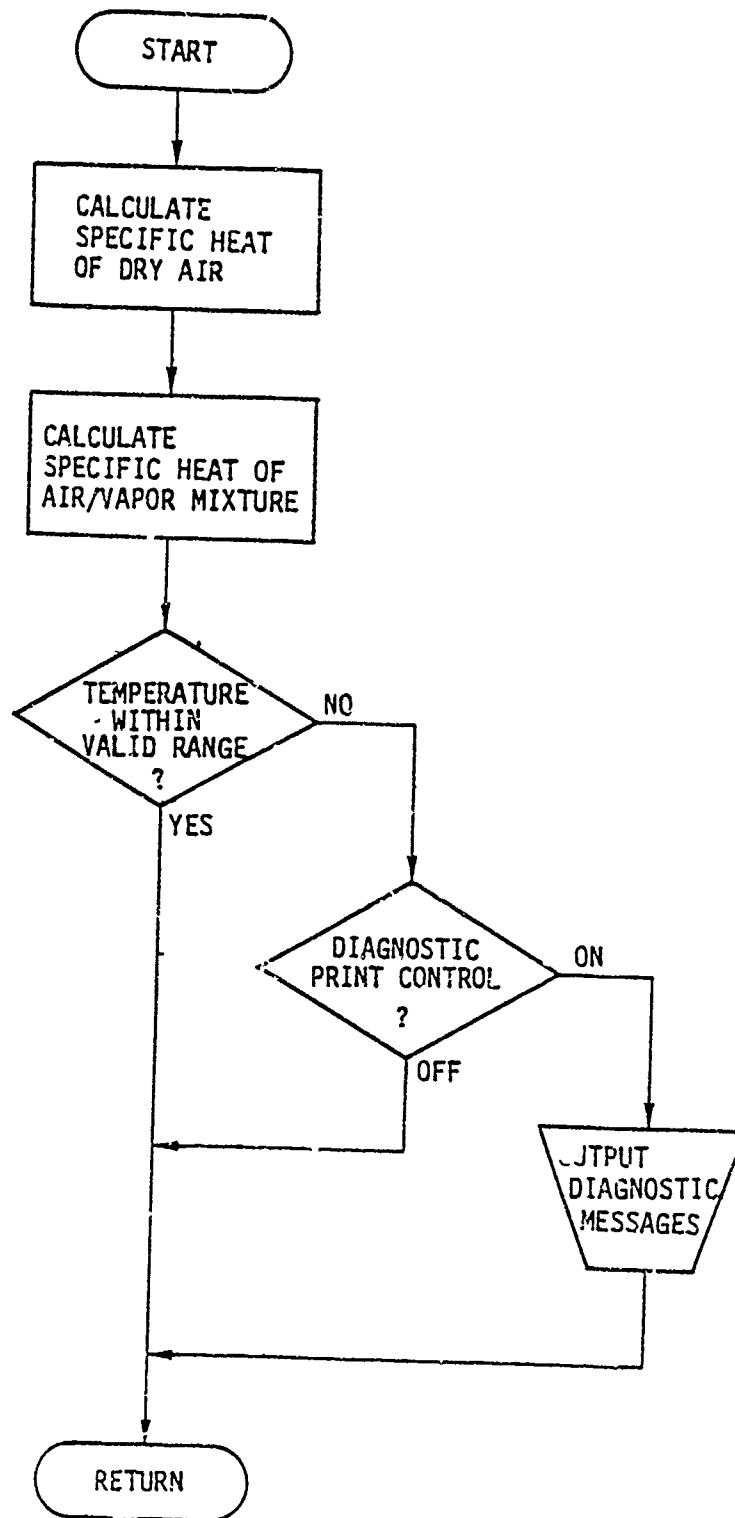

Table 89: FLOWCHART FOR SUBROUTINE SIDEFS

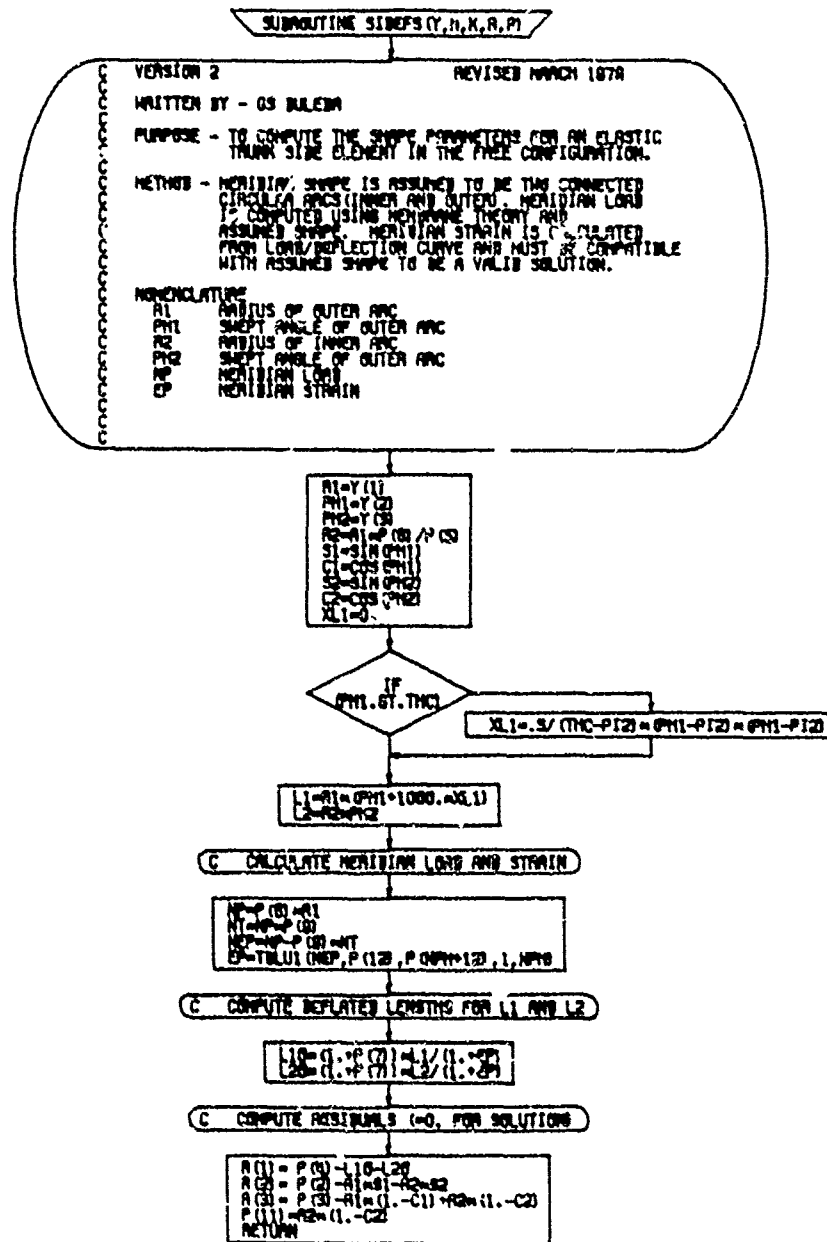

Table 90: FLOWCHART FOR SUBROUTINE SIDELS

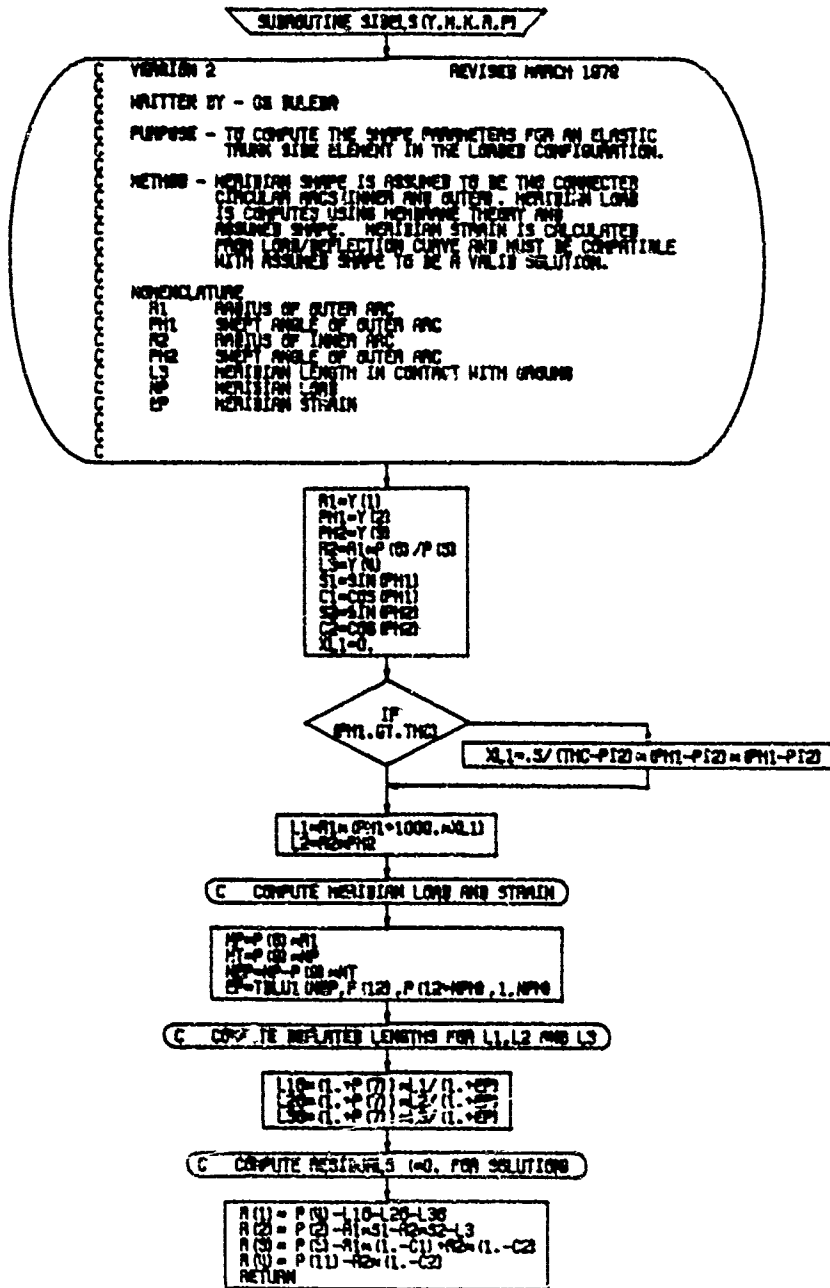
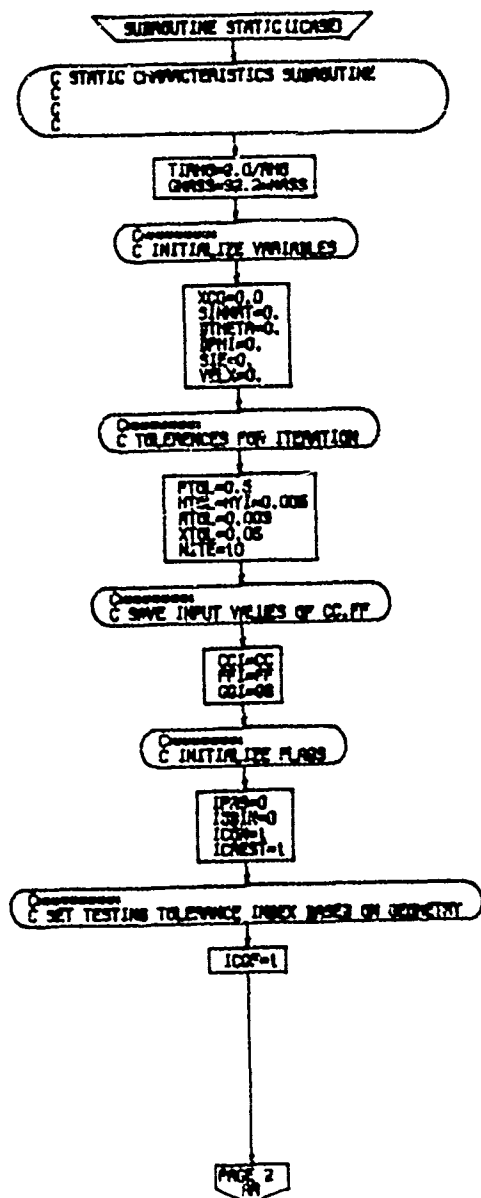

Table 91: FLOWCHART FOR SUBROUTINE STATIC



PAGE 1
STAT.C

Table 91: FLOWCHART FOR SUBROUTINE STATIC (CONTINUED)

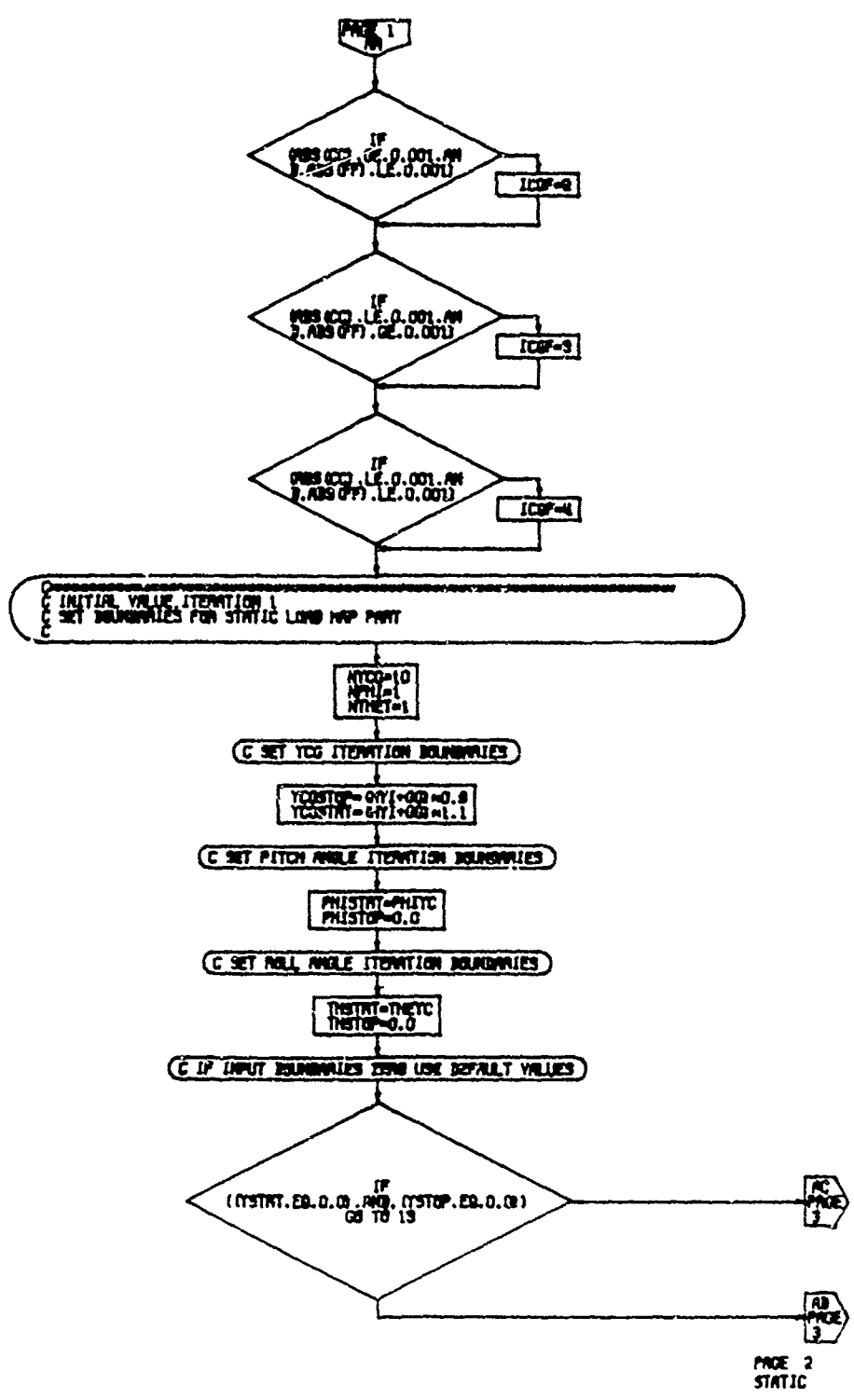
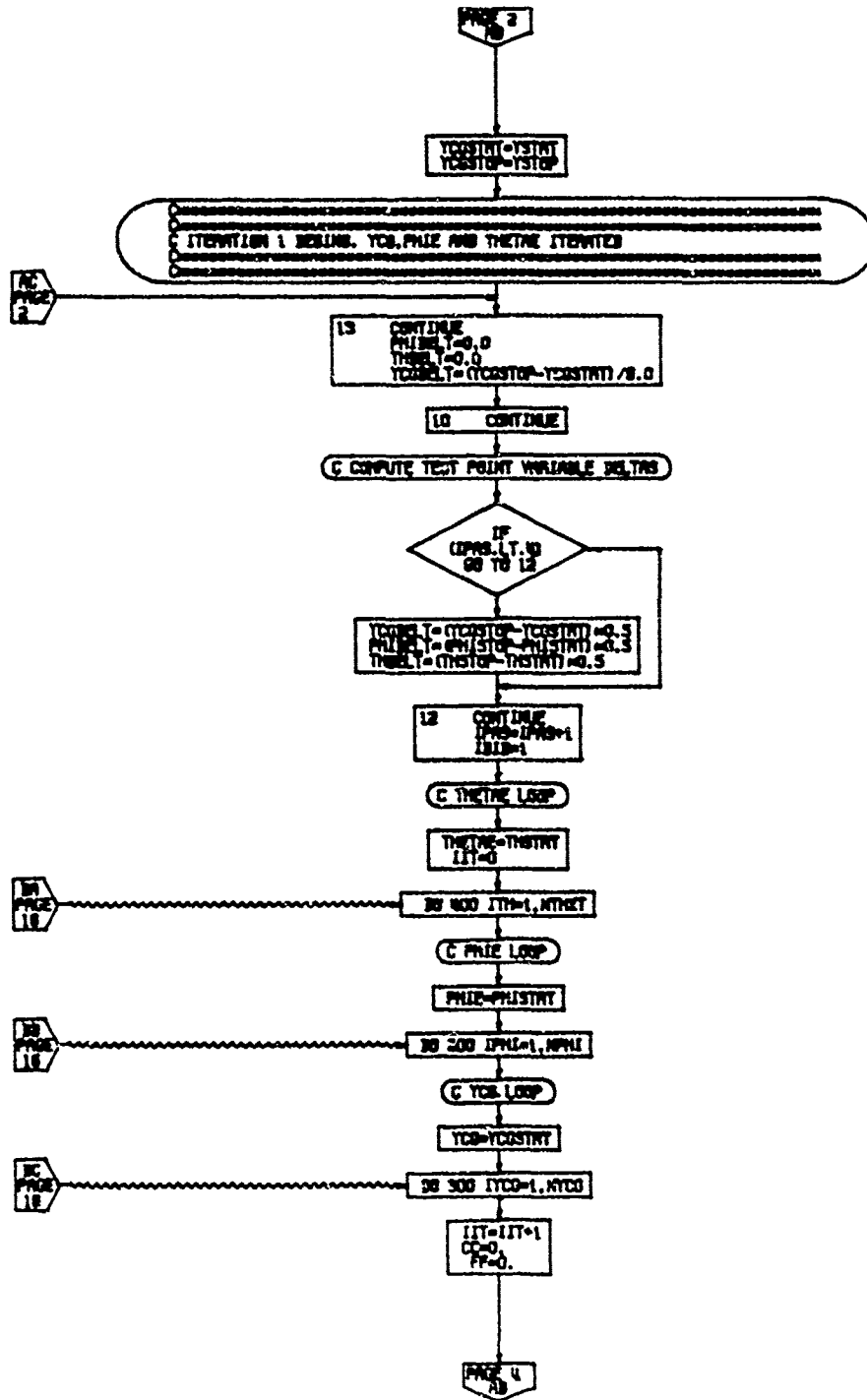
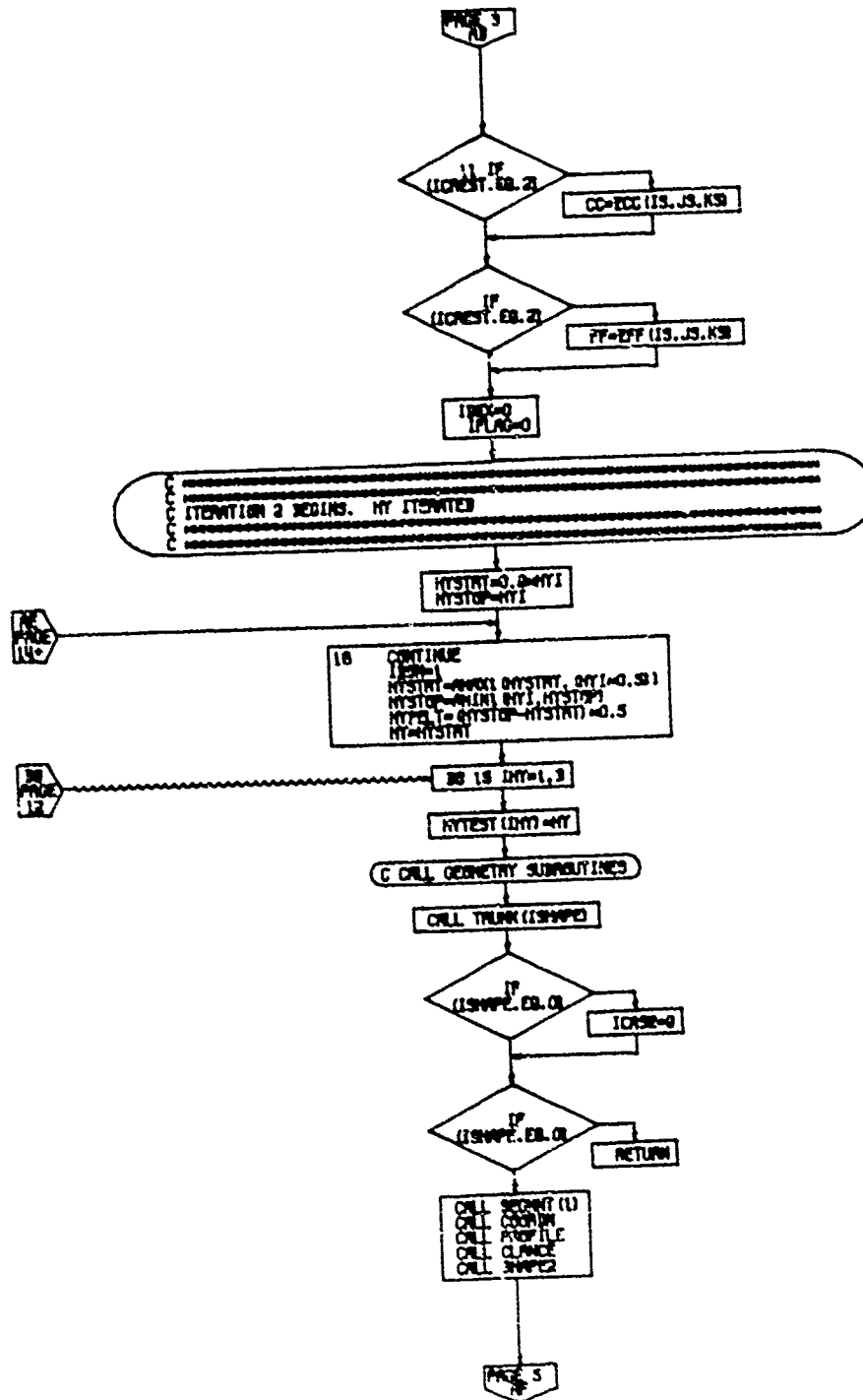

Table 91: FLOWCHART FOR SUBROUTINE STATIC (CONTINUED)



PAGE 3
STATIC

Table 91: FLOWCHART FOR SUBROUTINE STATIC (CONTINUED)



PAGE 4
STATIC

Table 91: FLOWCHART FOR SUBROUTINE STATIC (CONTINUED)

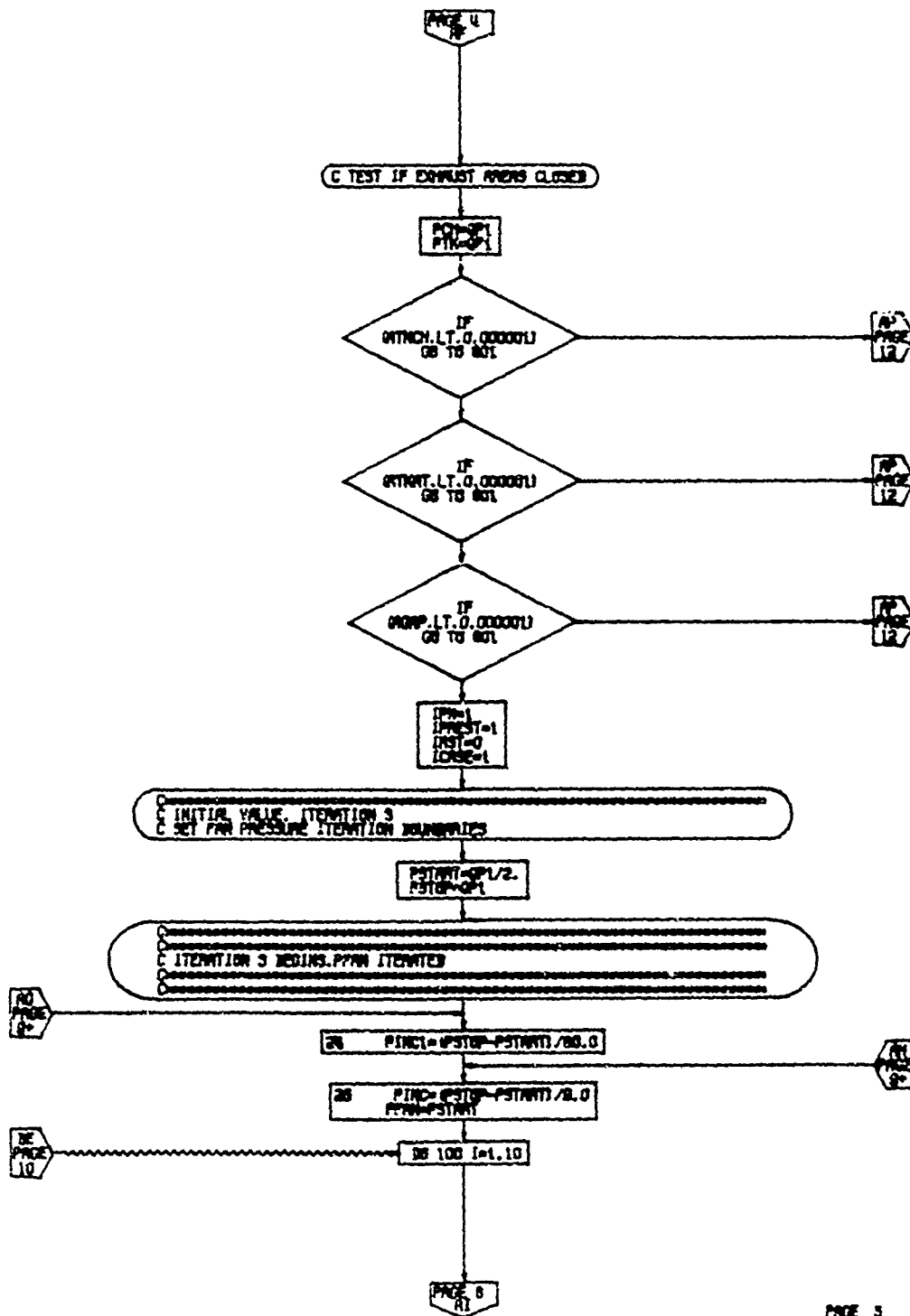

PAGE 5
STATIC

Table 91: FLOWCHART FOR SUBROUTINE STATIC (CONTINUED)

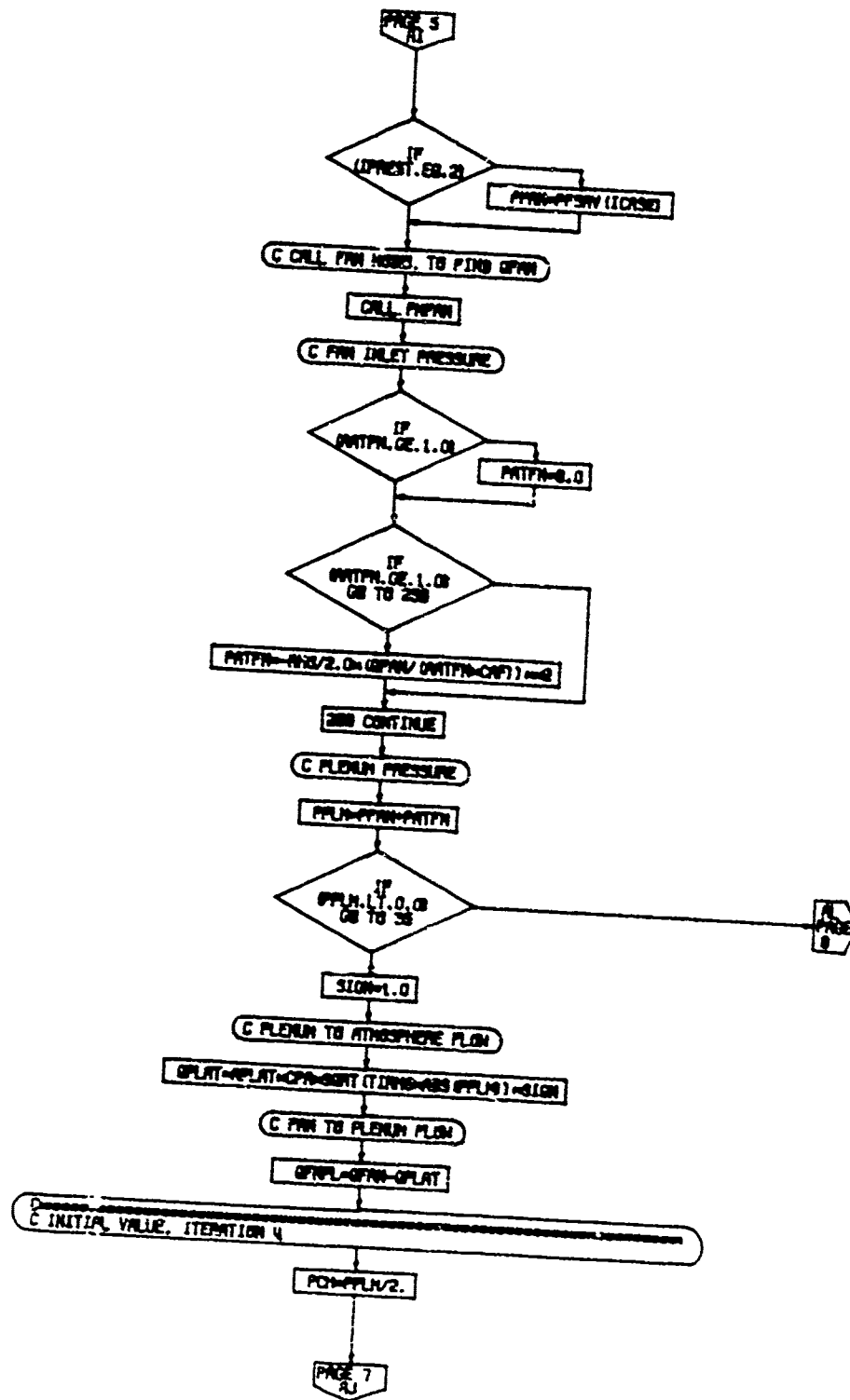

PAGE 6
STATIC

Table 91: FLOWCHART FOR SUBROUTINE STATIC (CONTINUED)

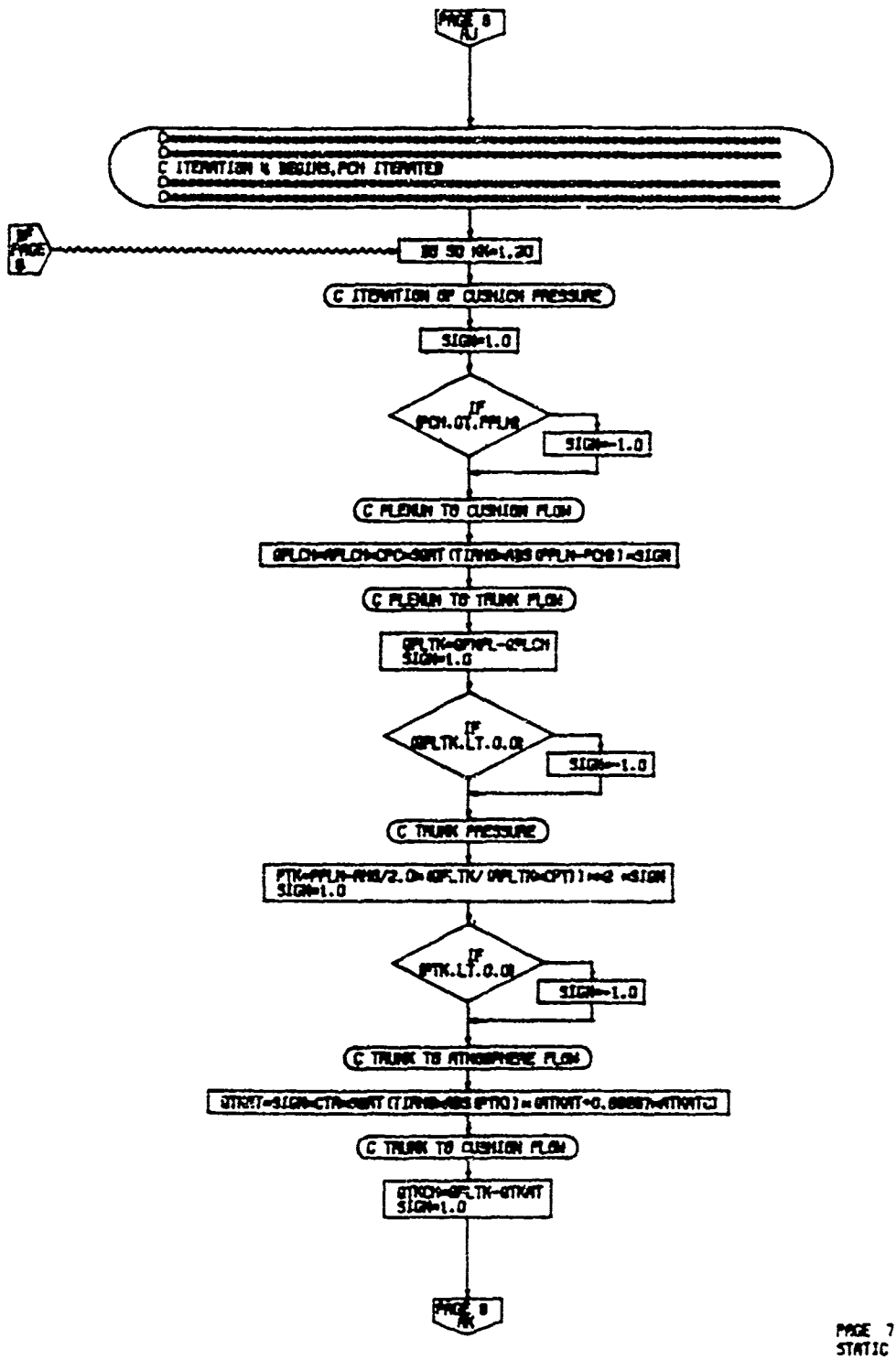
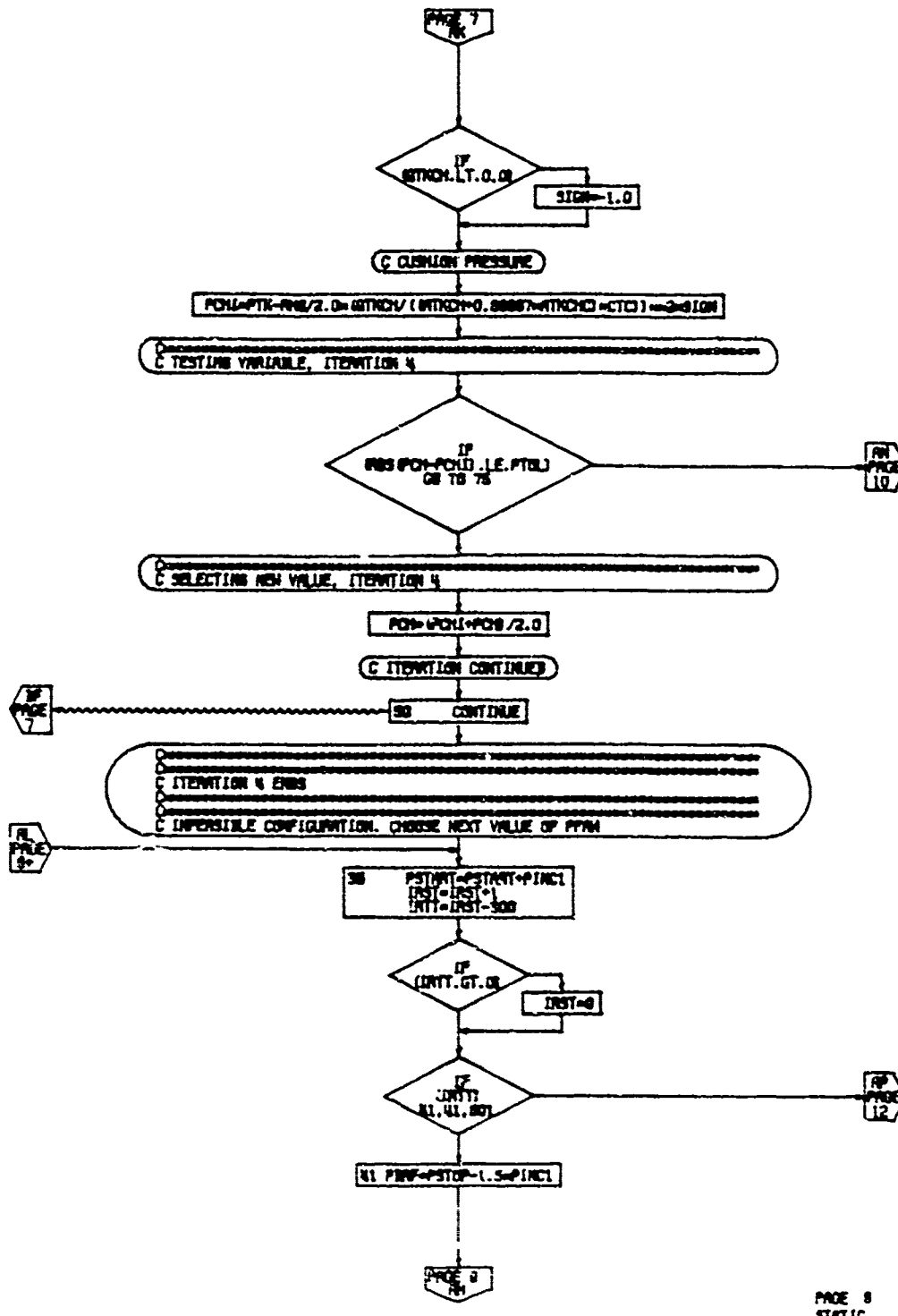
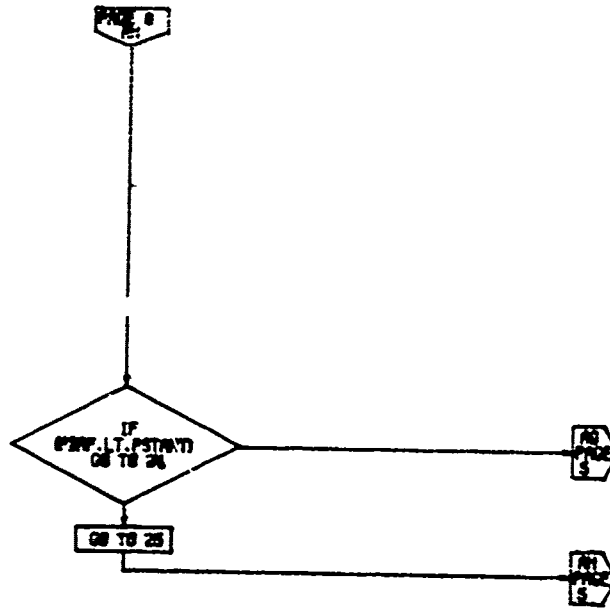

Table 91: FLOWCHART FOR SUBROUTINE STATIC (CONTINUED)



PAGE 8
STATIC

Table 91: FLOWCHART FOR SUBROUTINE STATIC (CONTINUED)



PAGE 8
STATIC

Table 91: FLOWCHART FOR SUBROUTINE STATIC (CONTINUED)

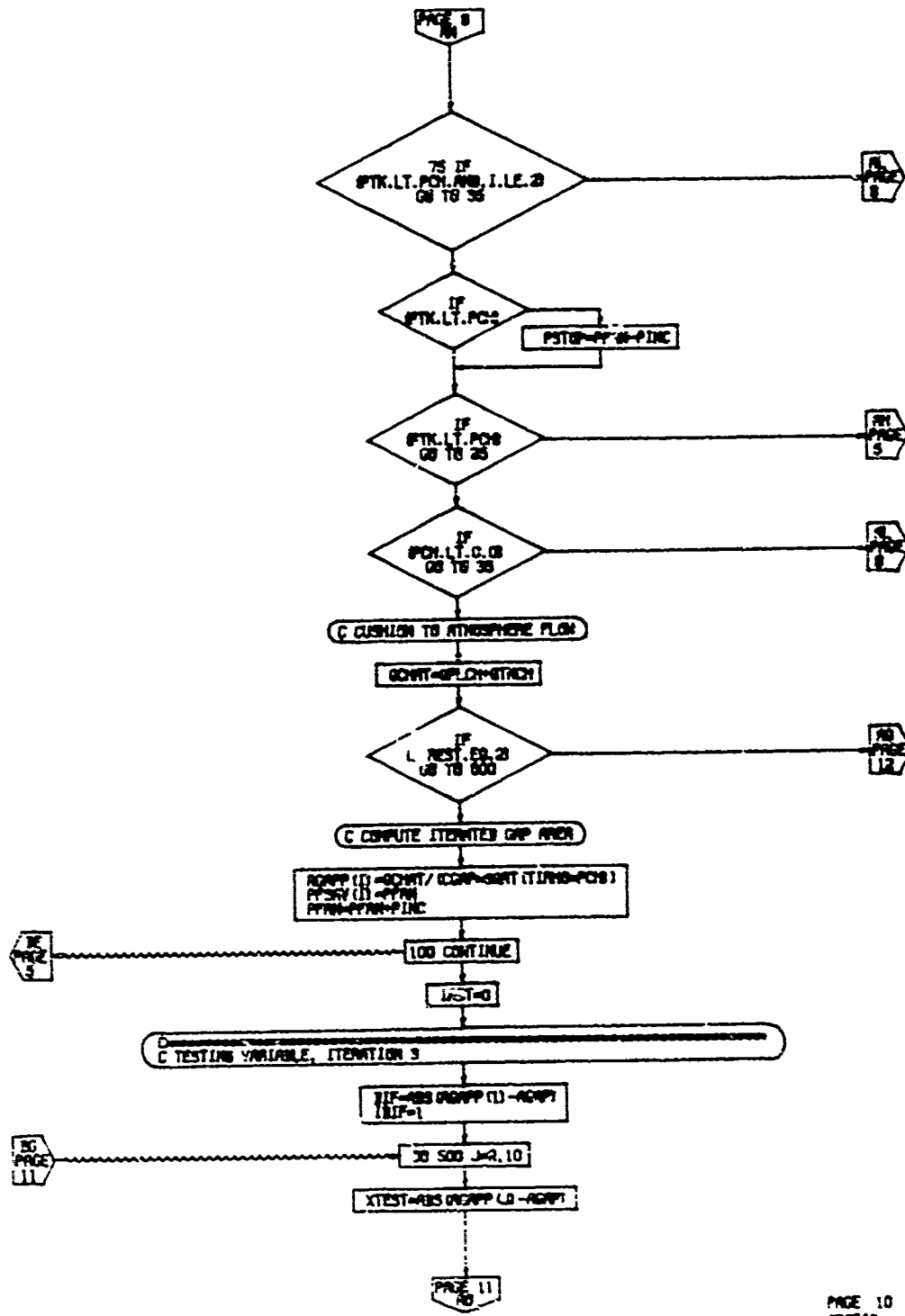

PAGE 10
STATIC

Table 91: FLOWCHART FOR SUBROUTINE STATIC (CONTINUED)

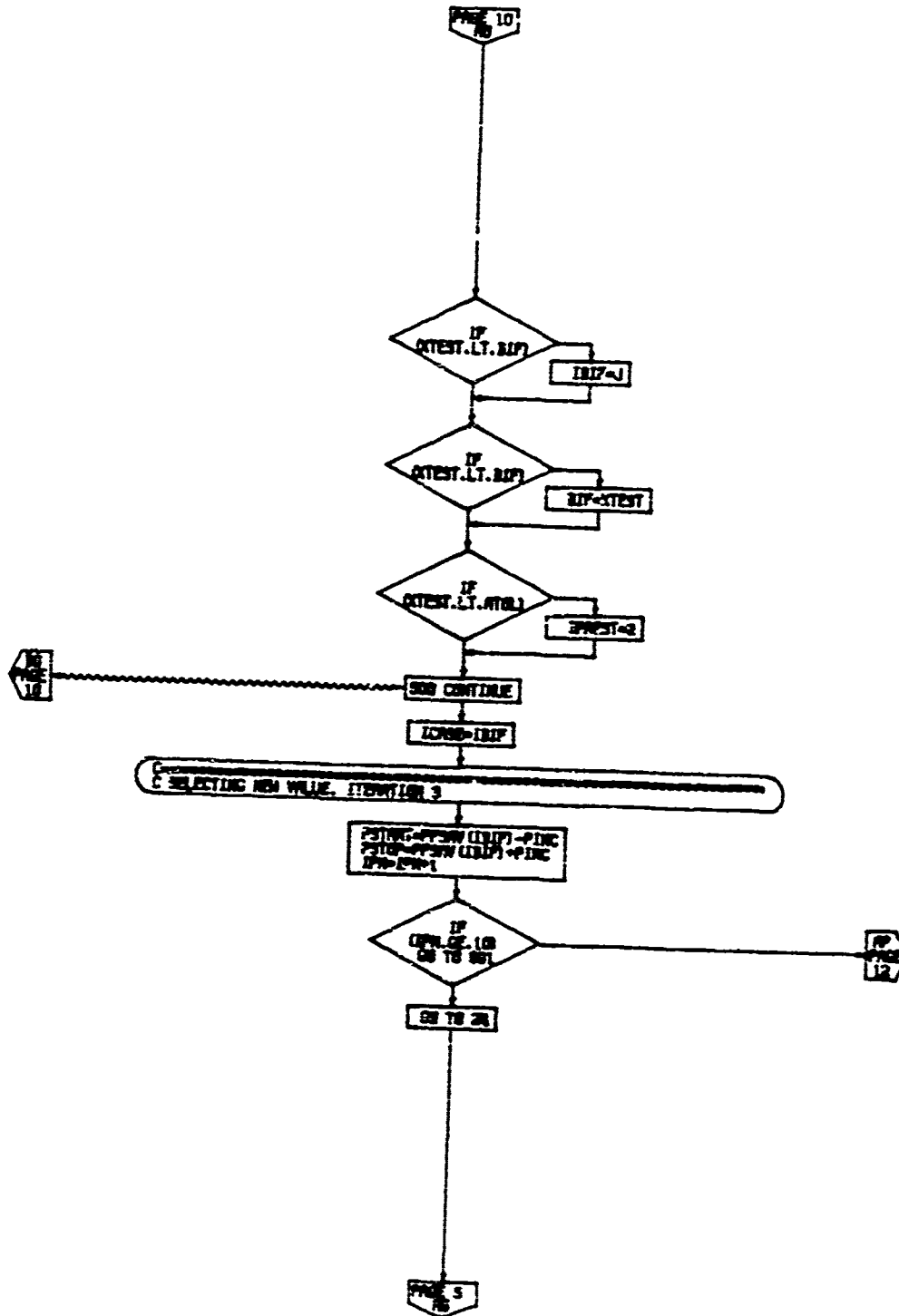

PAGE 11
STATIC

Table 91: FLOWCHART FOR SUBROUTINE STATIC (CONTINUED)

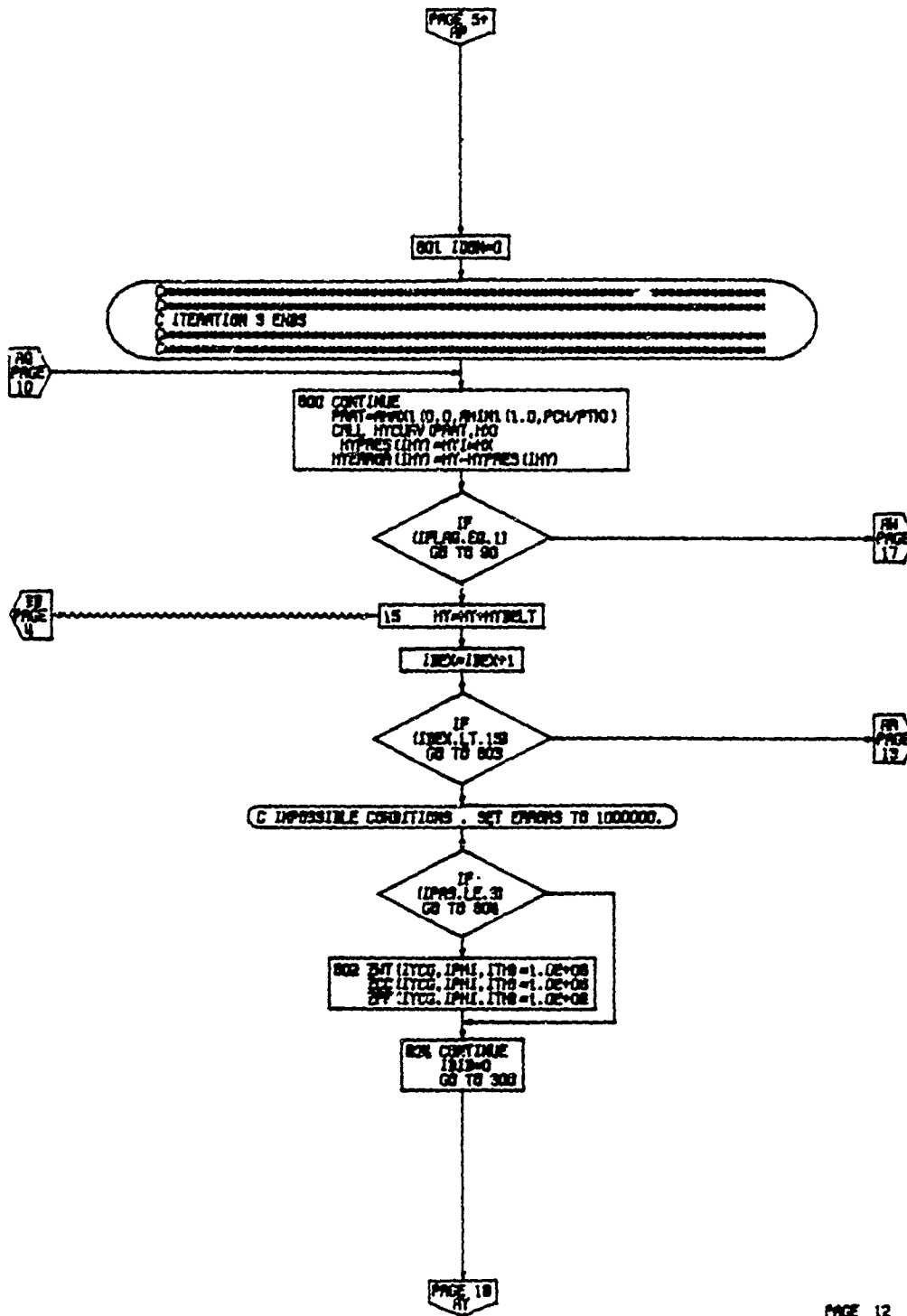

PAGE 12
STATIC

Table 91: FLOWCHART FOR SUBROUTINE STATIC (CONTINUED)

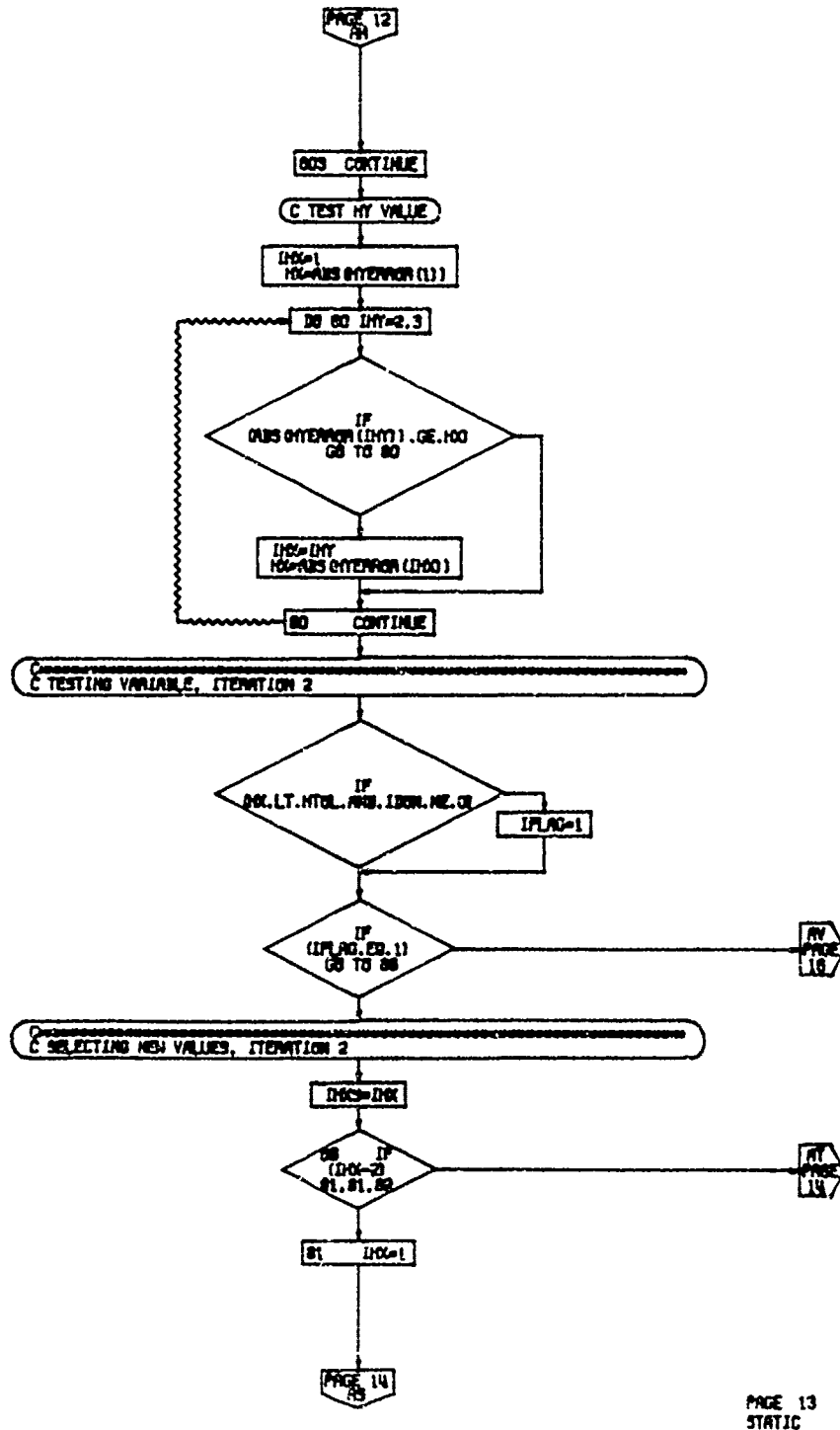

PAGE 13
STATIC

Table 91: FLOWCHART FOR SBURROUTINE STATIC (CONTINUED)

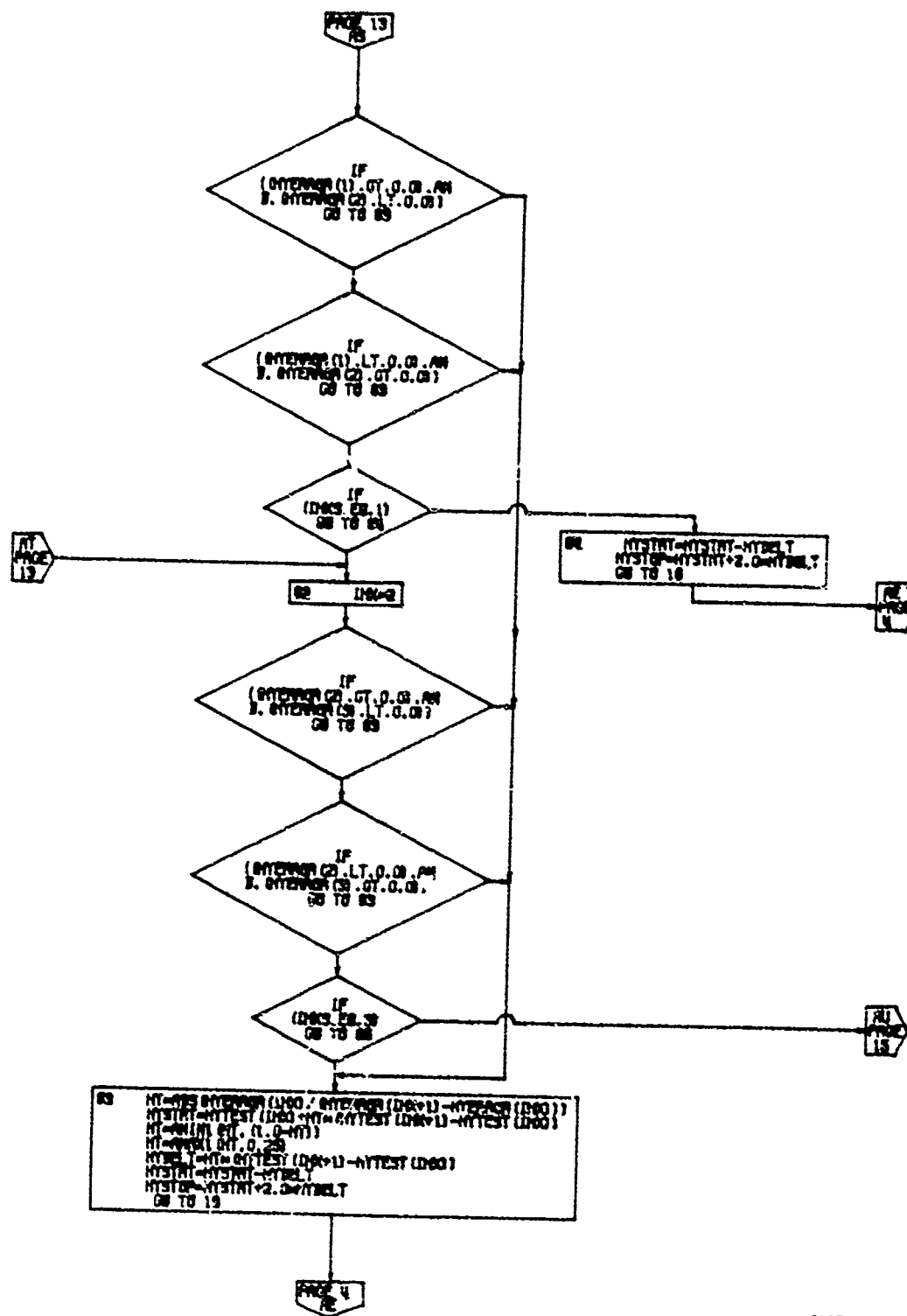

PAGE 14
STATIC

Table 91: FLOWCHART FOR SUBROUTINE STATIC (CONTINUED)

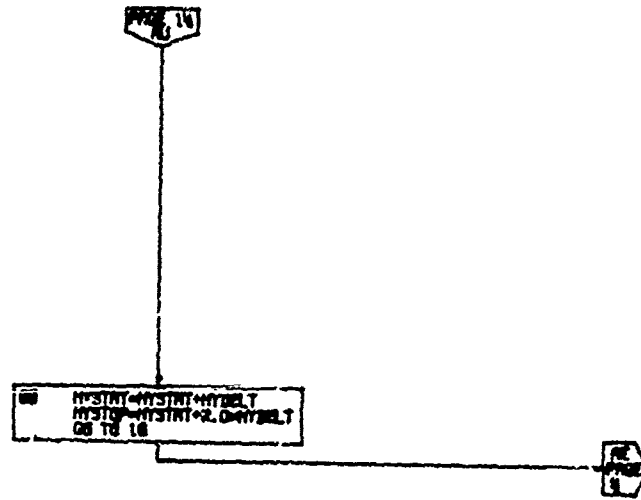

PAGE 15
STATIC

Table 91: FLOWCHART FOR SUBROUTINE STATIC (CONTINUED)

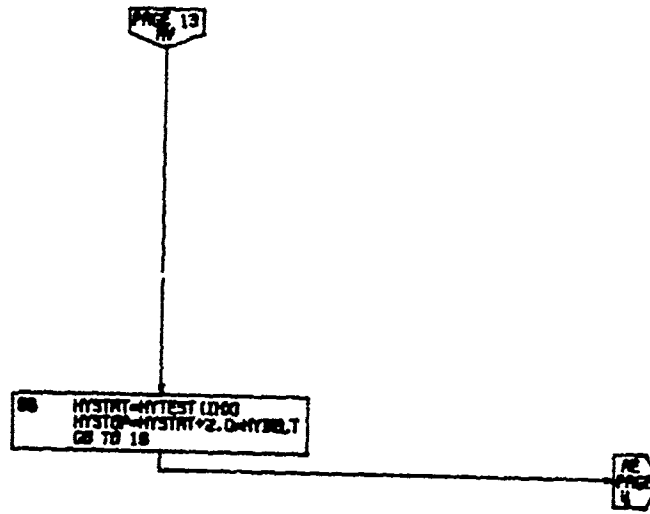

PAGE 18
STATIC

Table 91: FLOWCHART FOR SUBROUTINE STATIC (CONTINUED)

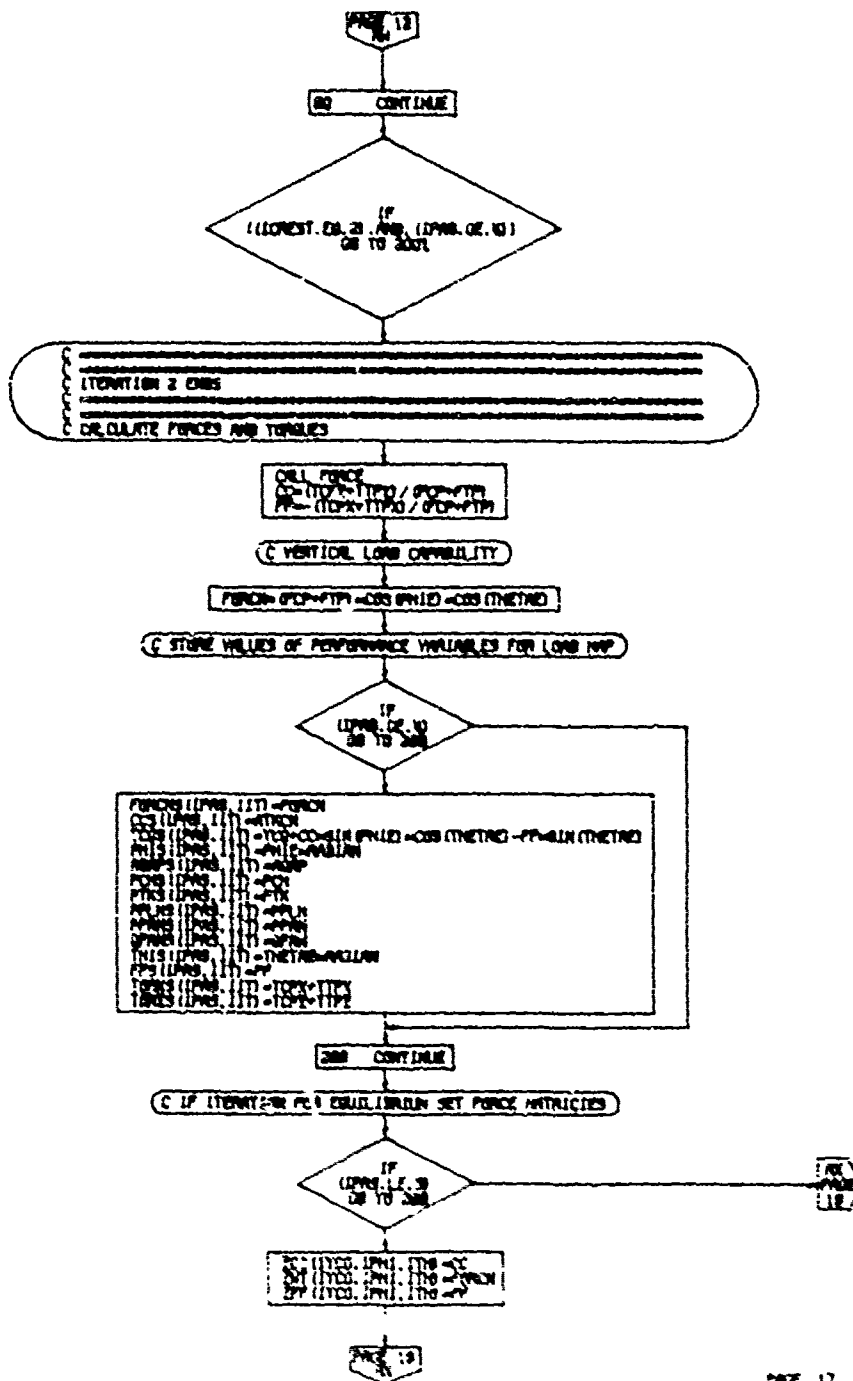

PAGE 17
STATIC

Table 91: FLOWCHART FOR SUBROUTINE STATIC (CONTINUED)

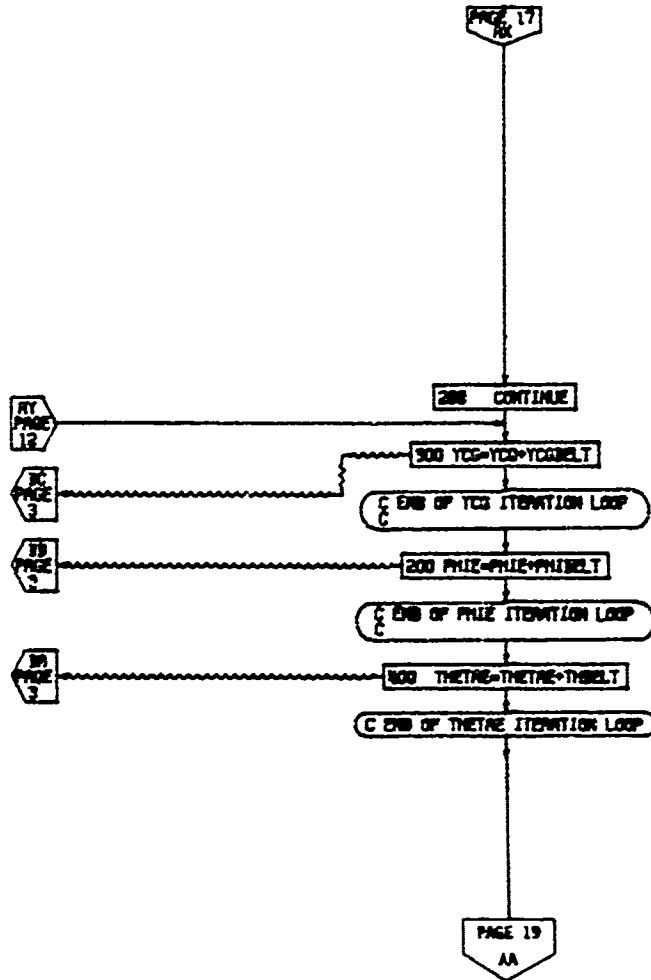

PAGE 18
STATIC

Table 91: FLOWCHART FOR SUBROUTINE STATIC (CONTINUED)

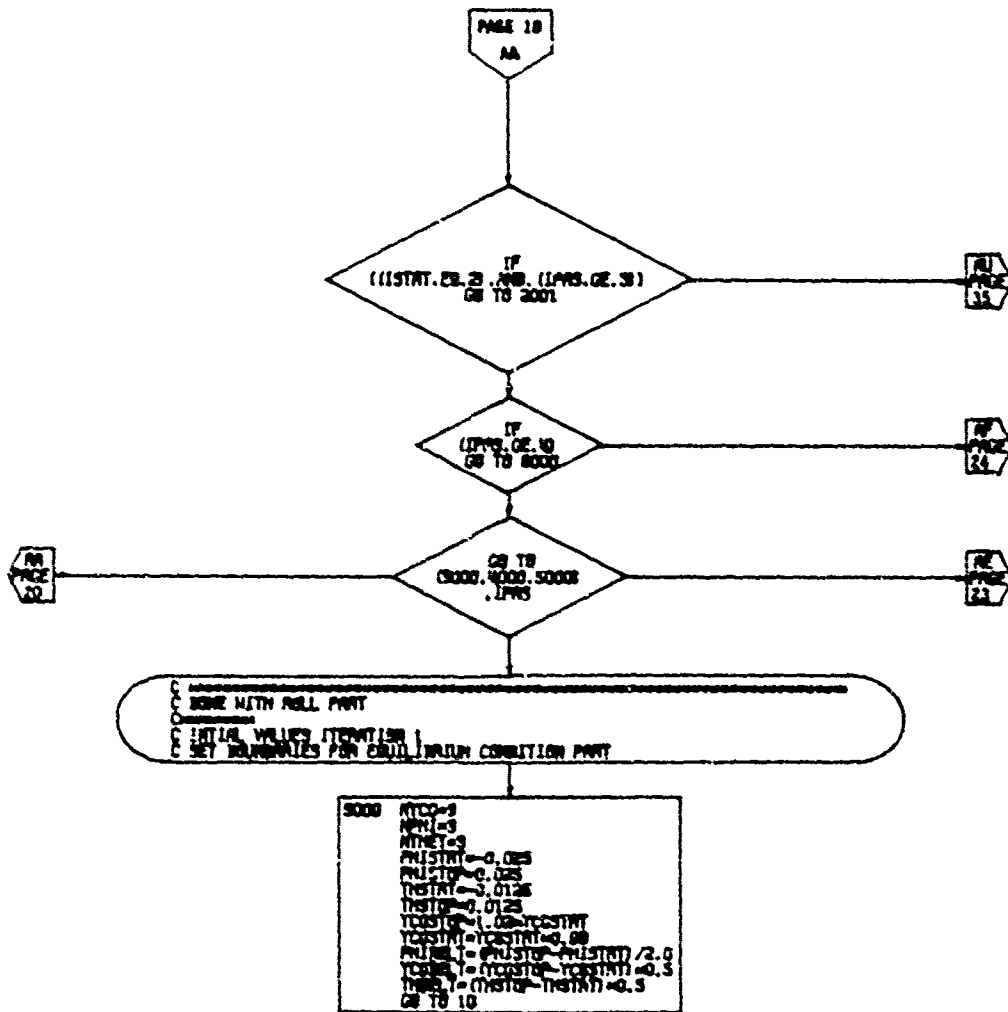

PAGE 19
STATIC

Table 91: FLOWCHART FOR SUBROUTINE STATIC (CONTINUED)

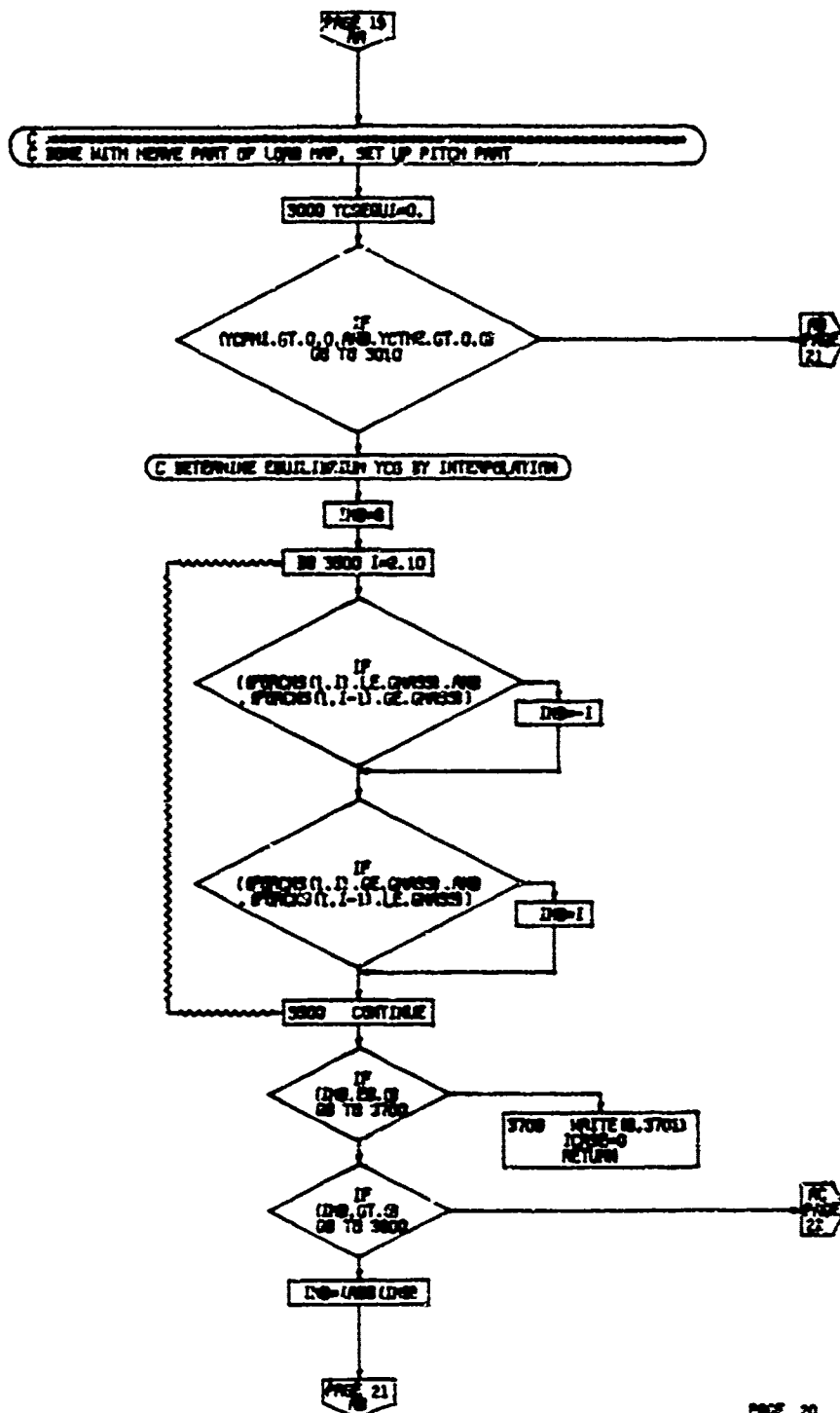

PAGE 20
STATIC

Table 91: FLOWCHART FOR SUBROUTINE STATIC (CONTINUED)

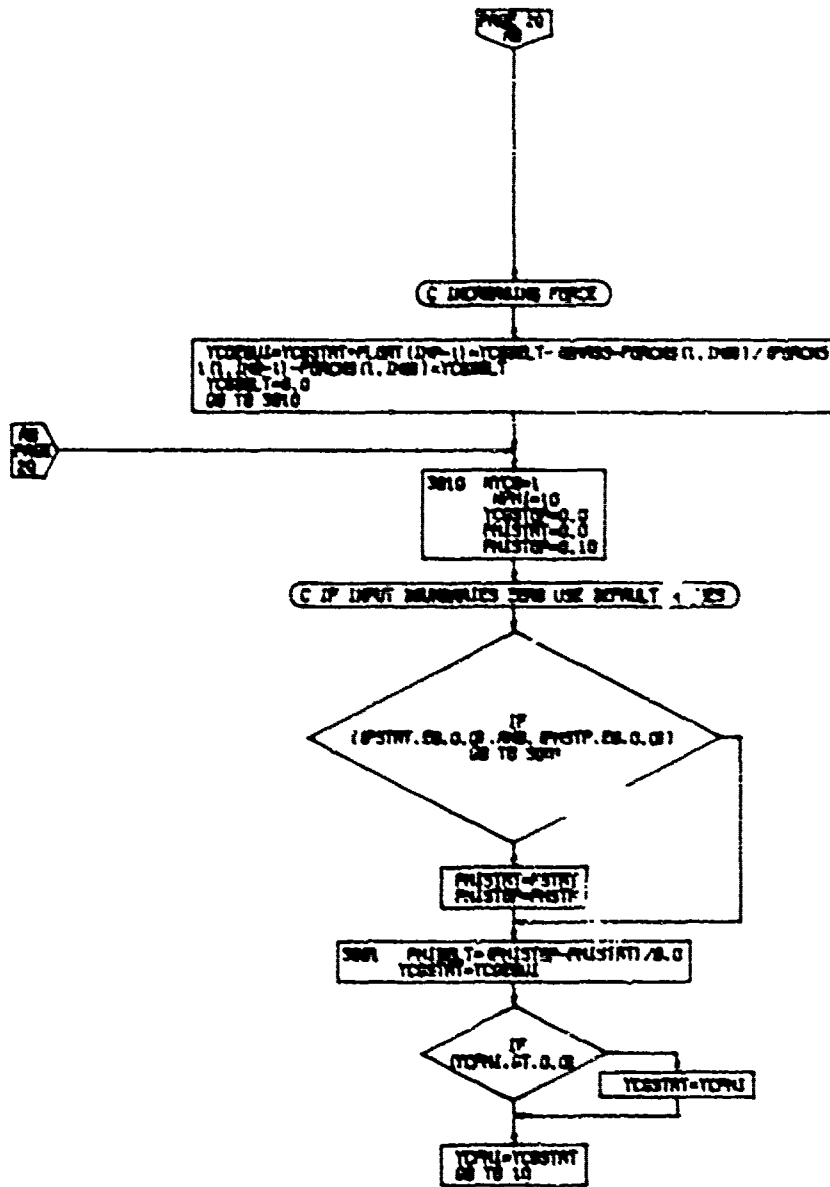
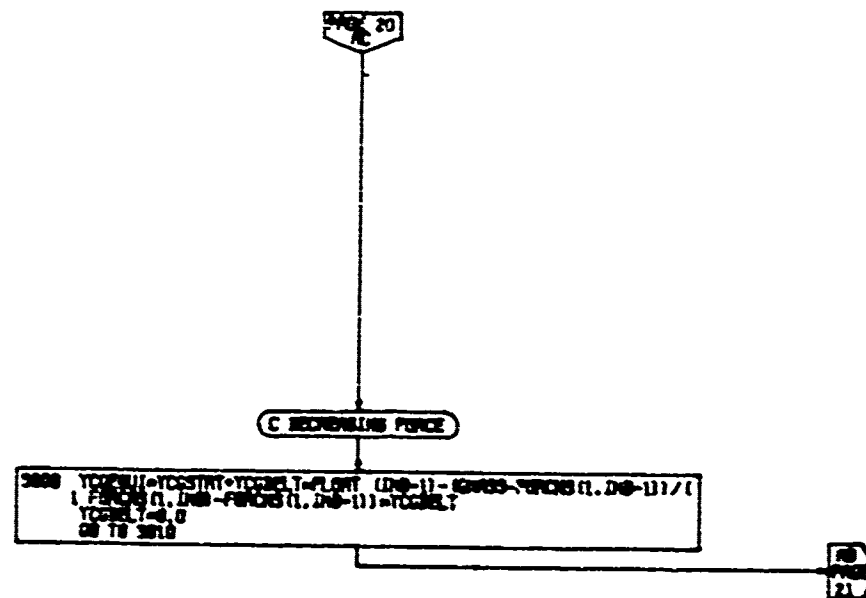

Table 91: FLOWCHART FOR SUBROUTINE STATIC (CONTINUED)



PAGE 72
STATIC

Table 91: FLOWCHART FOR SUBROUTINE STATIC (CONTINUED)

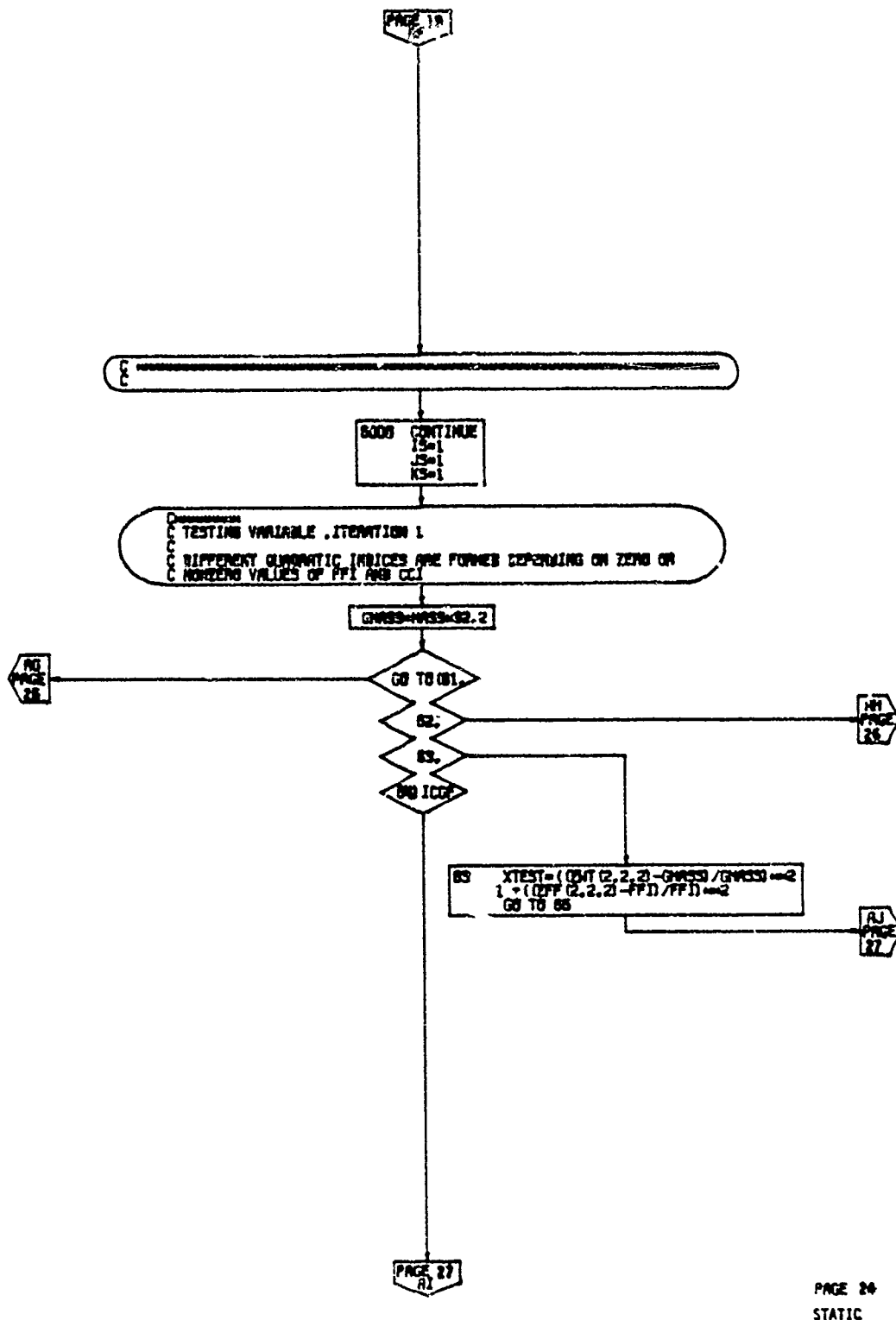
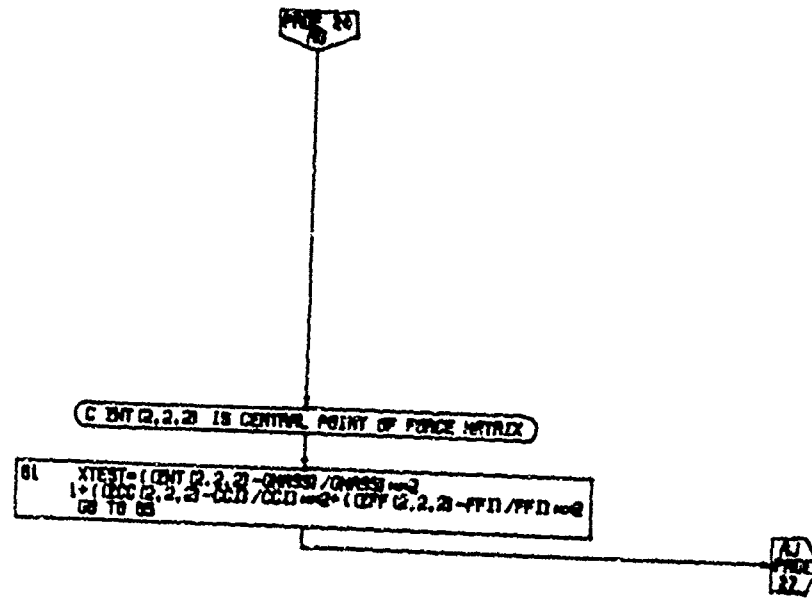

Table 91: FLOWCHART FOR SUBROUTINE STATIC (CONTINUED)



PAGE 20
STATIC

Table 91: FLOWCHART FOR SUBROUTINE STATIC (CONTINUED)

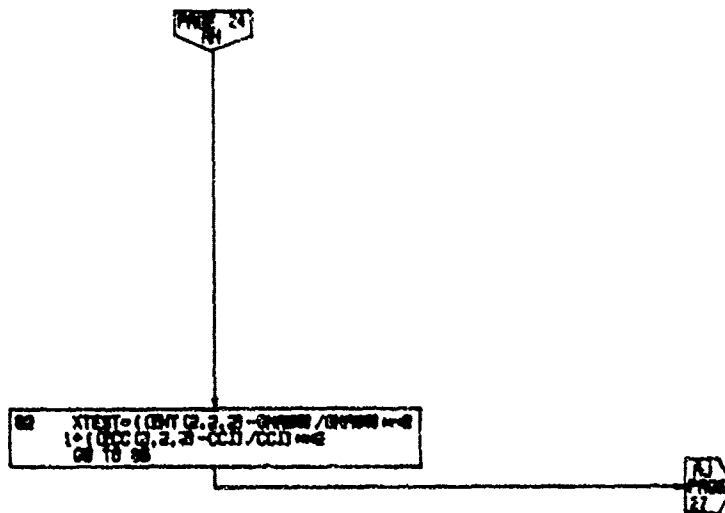
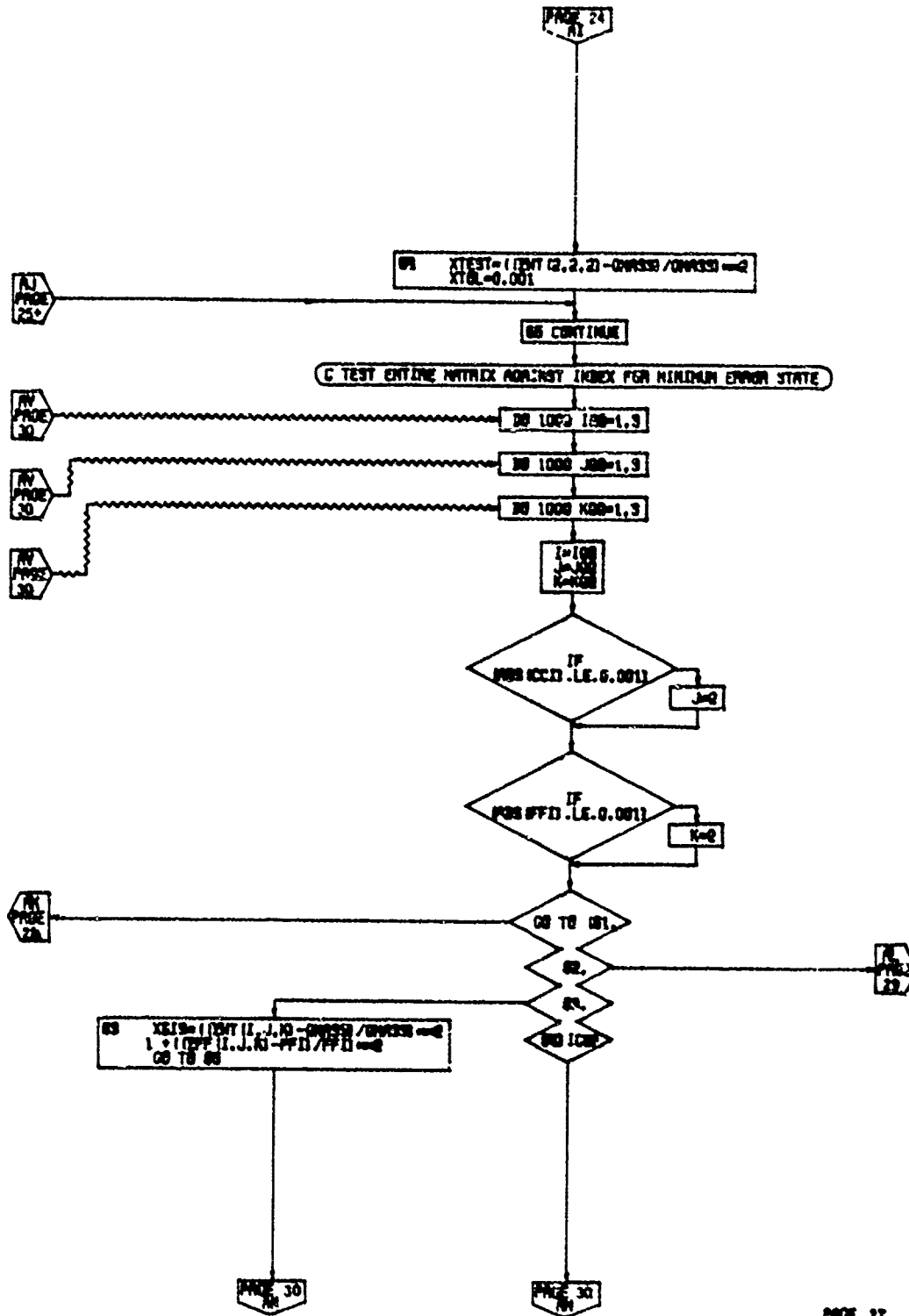
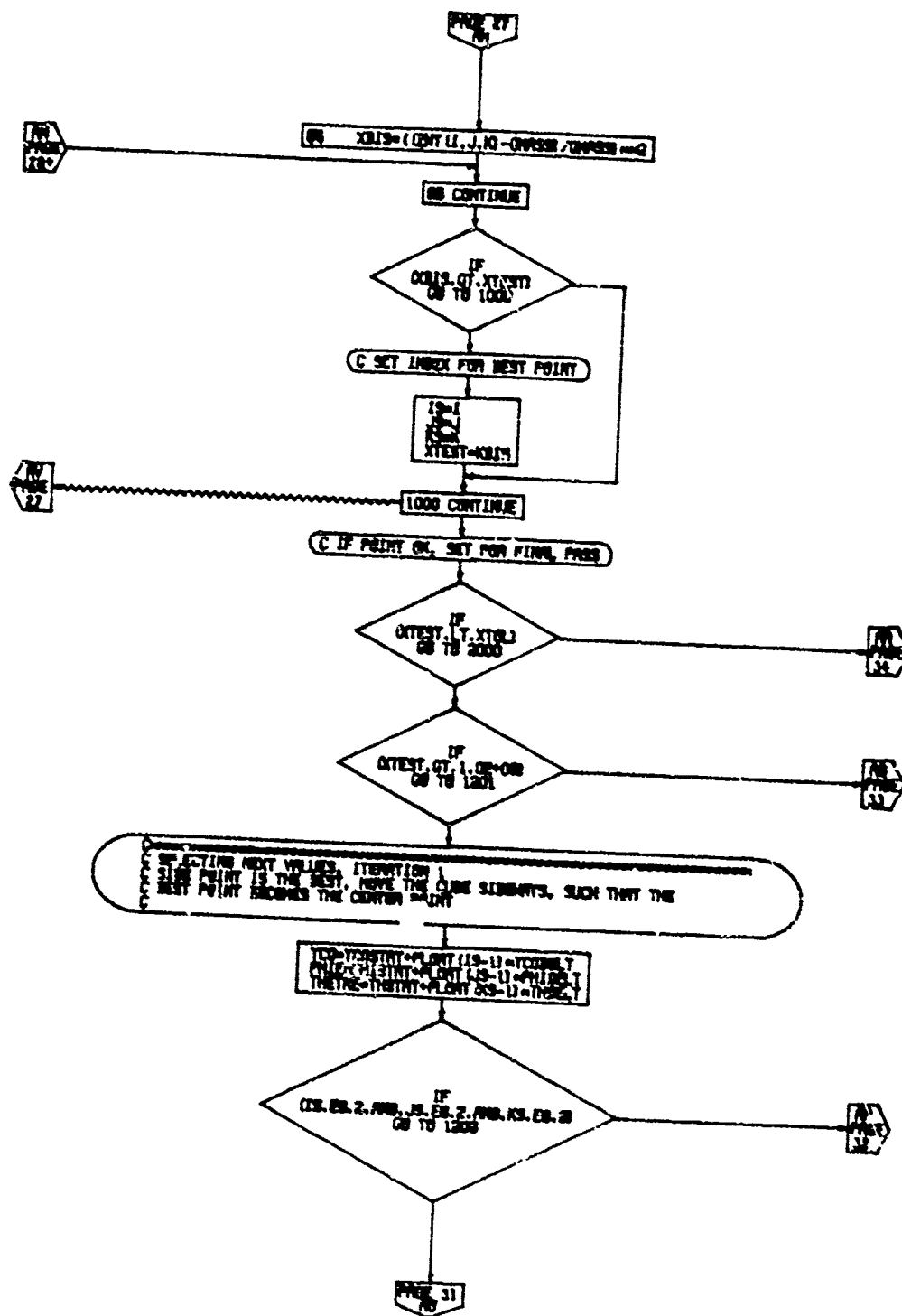

Table 91: FLOWCHART FOR SUBROUTINE STATIC (CONTINUED)



PAGE 27
STATIC

Table 91: FLOWCHART FOR SUBROUTINE STATIC (CONTINUED)



PAGE 30
STATIC

Table 91: FLOWCHART FOR SUBROUTINE STATIC (CONTINUED)

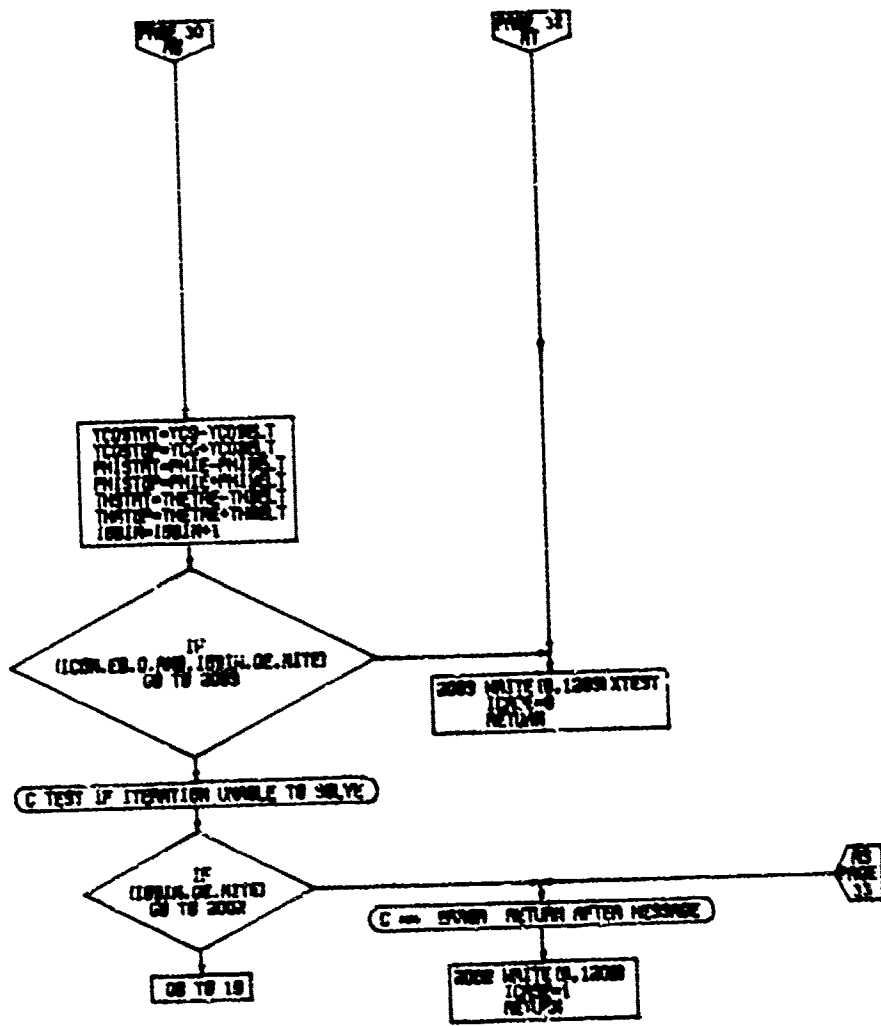

PAGE 31
STATIC

Table 91: FLOWCHART FOR SUBROUTINE STATIC (CONTINUED)

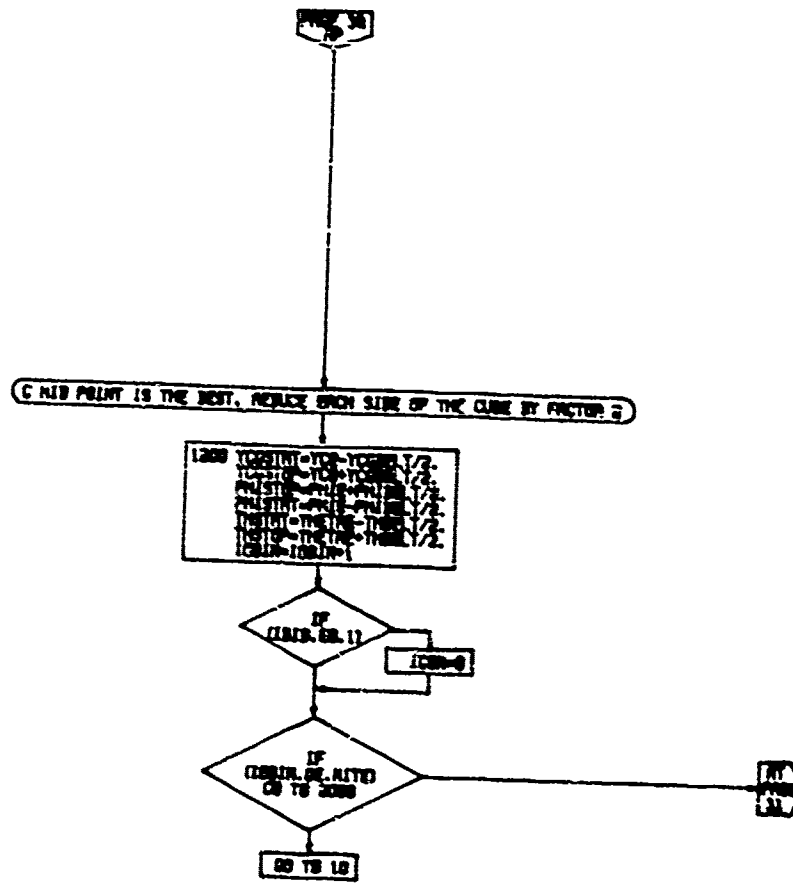
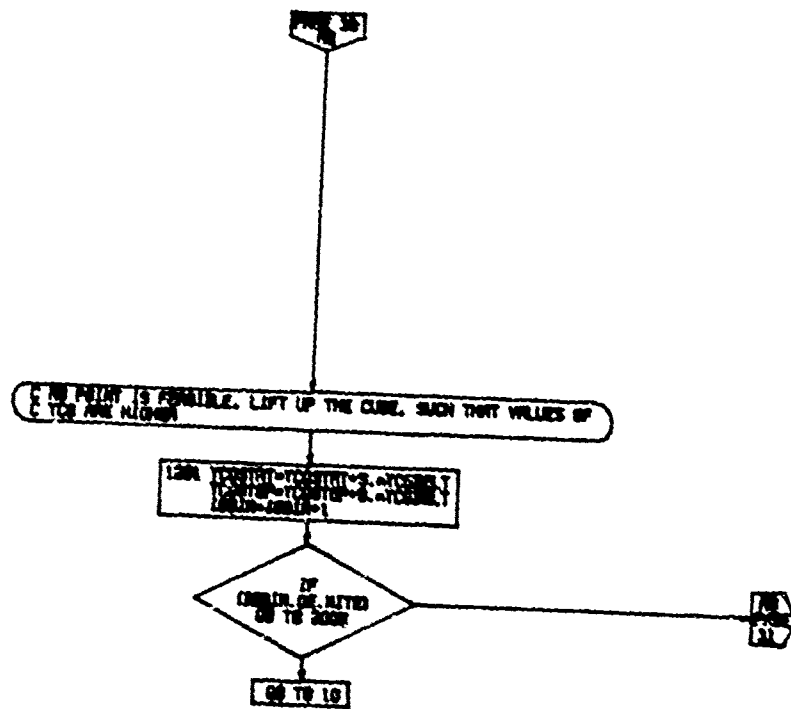
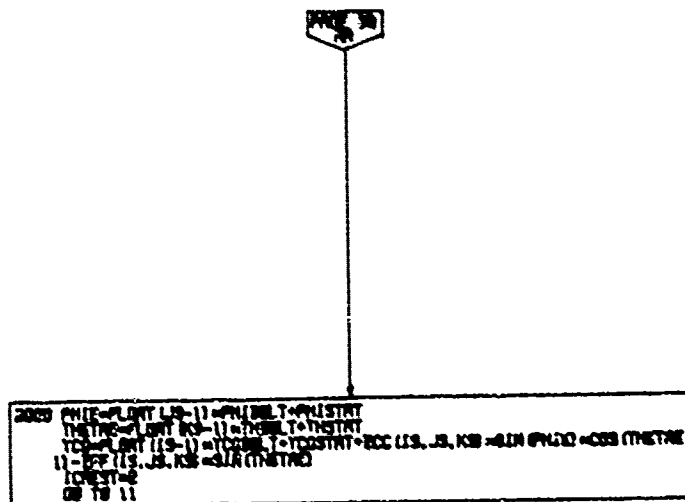

Table 91: FLOWCHART FOR SUBROUTINE STATIC (CONTINUED)



PAGE 33
STATIC

Table 91: FLOWCHART FOR SUBROUTINE STATIC (CONTINUED)



PAGE 34
STATIC

Table 91: FLOWCHART FOR SUBROUTINE STATIC (CONCLUDED)

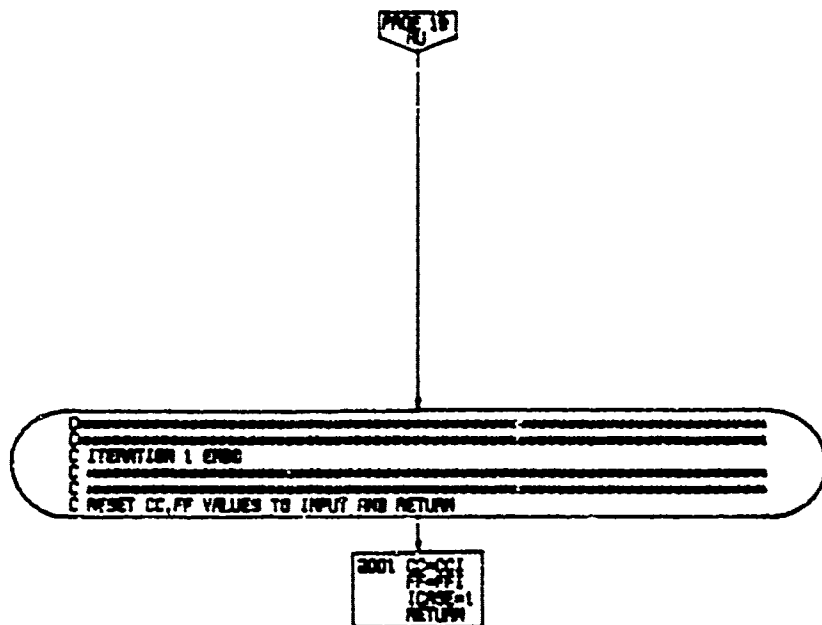

PAGE 18
STATIC

Table 92: FLOWCHART FOR SUBROUTINE STEQU

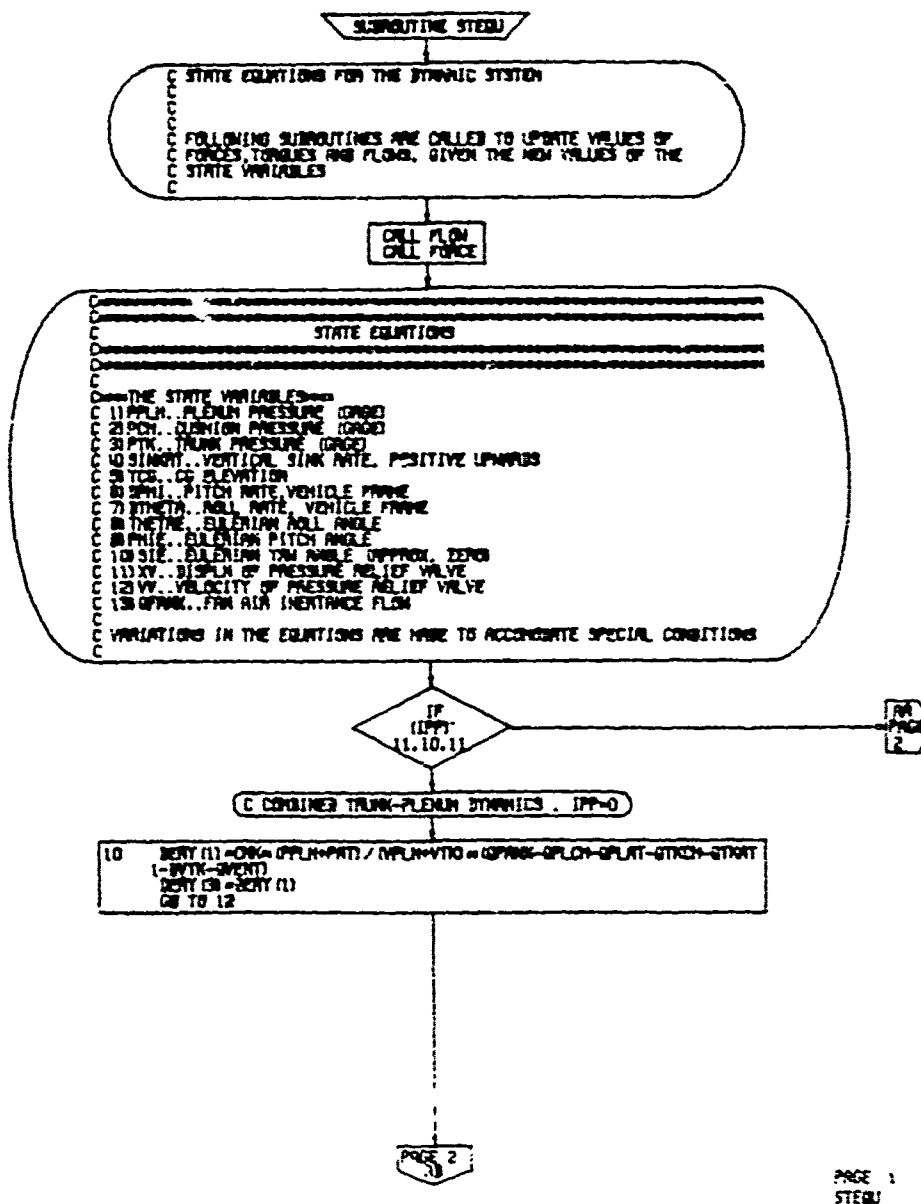
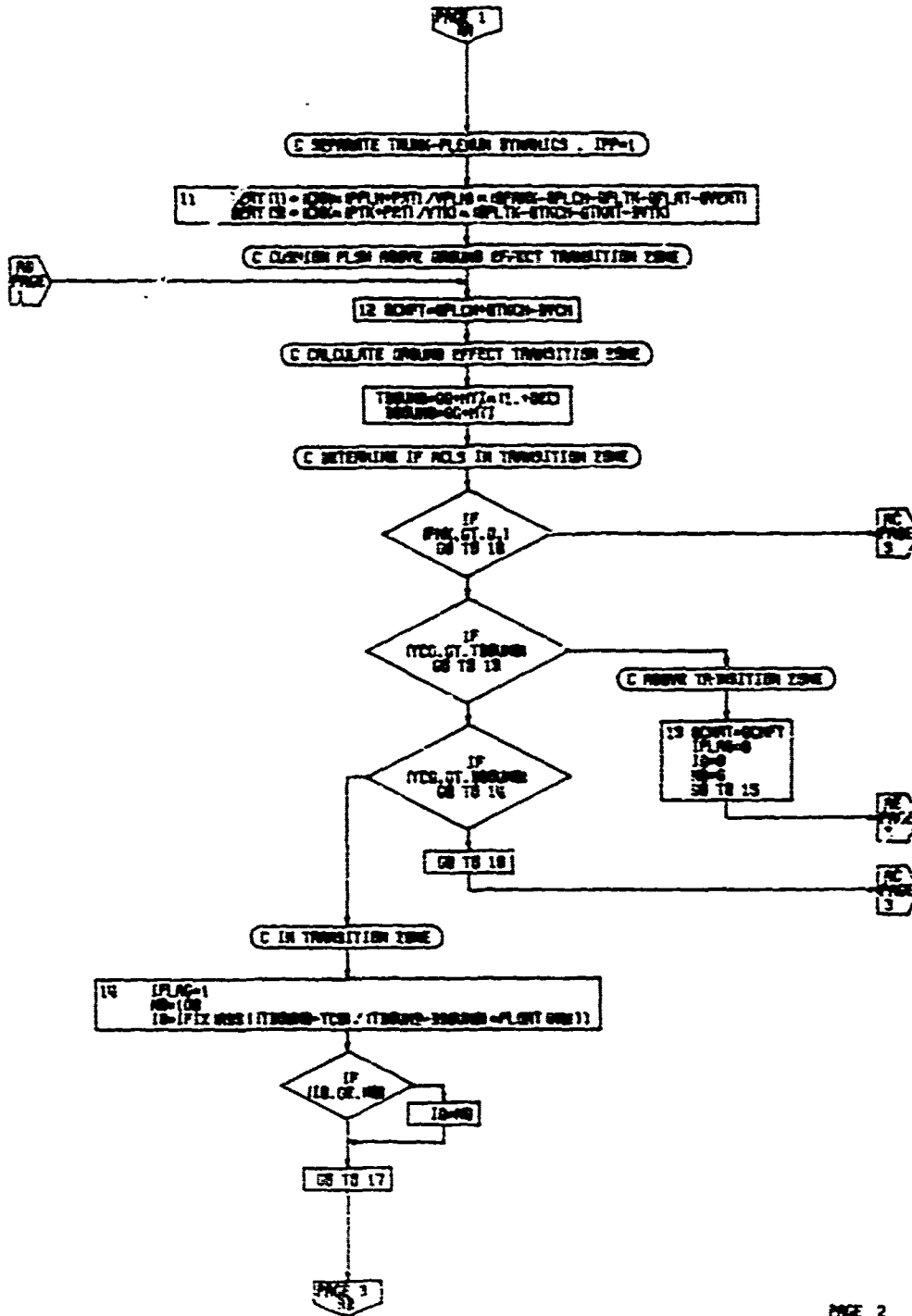
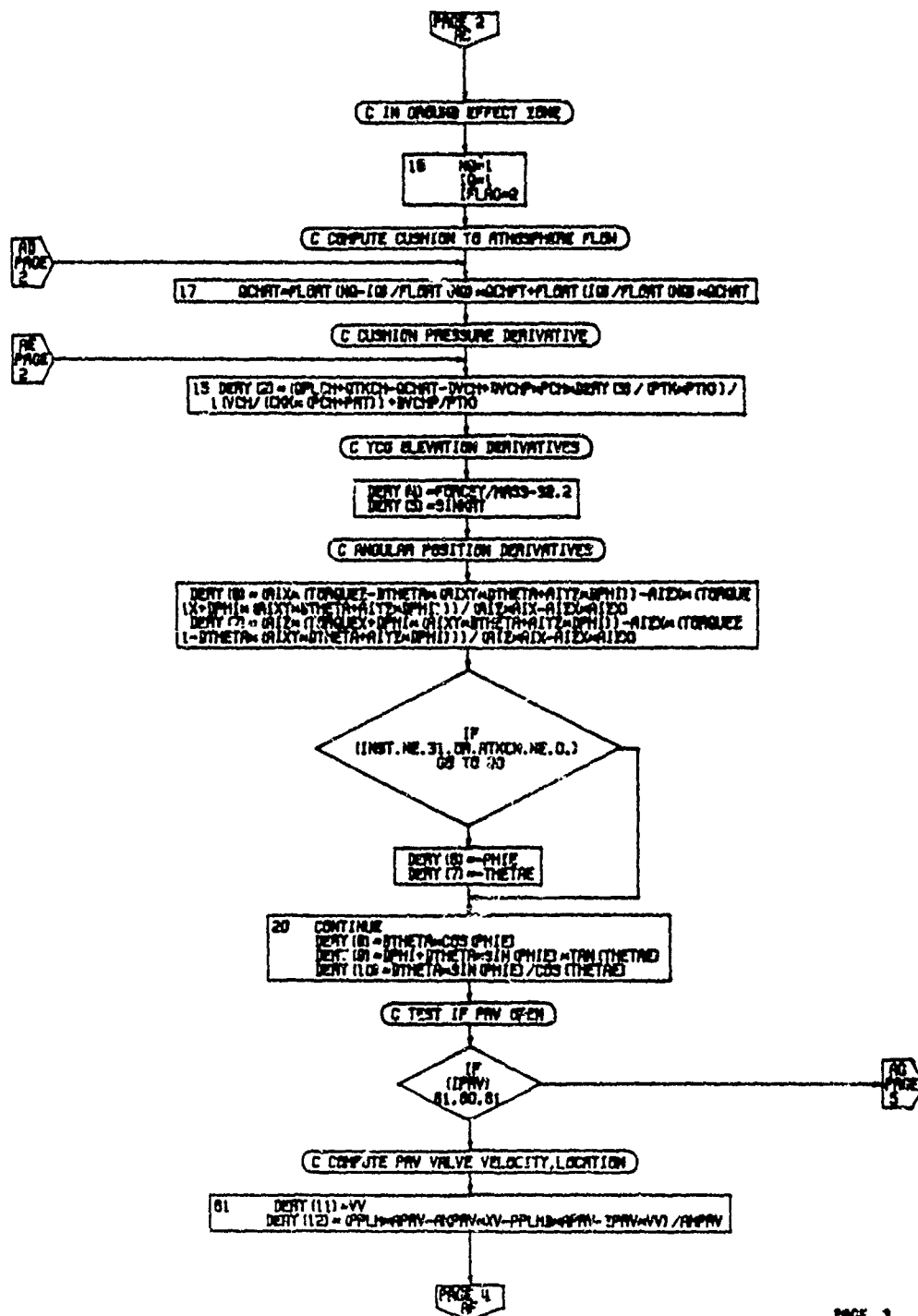

Table 92: FLOWCHART FOR SUBROUTINE STEQU (CONTINUED)



PAGE 2
STEQU

Table 92: FLOWCHART FOR SUBROUTINE STEQU (CONTINUED)



PAGE 3
STEQU

Table 92: FLOWCHART FOR SUBROUTINE STEQU (CONTINUED)

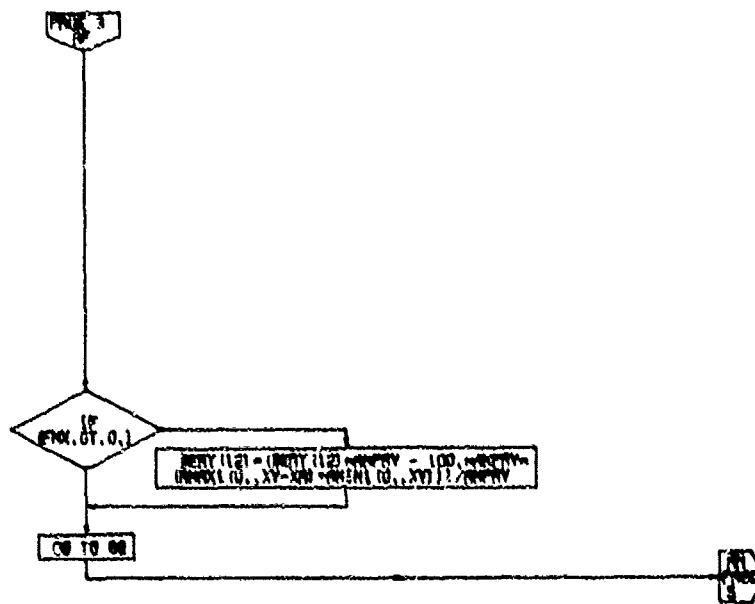

PAGE 4
STEQU

Table 92: FLOWCHART FOR SUBROUTINE STEQU (CONCLUDED)

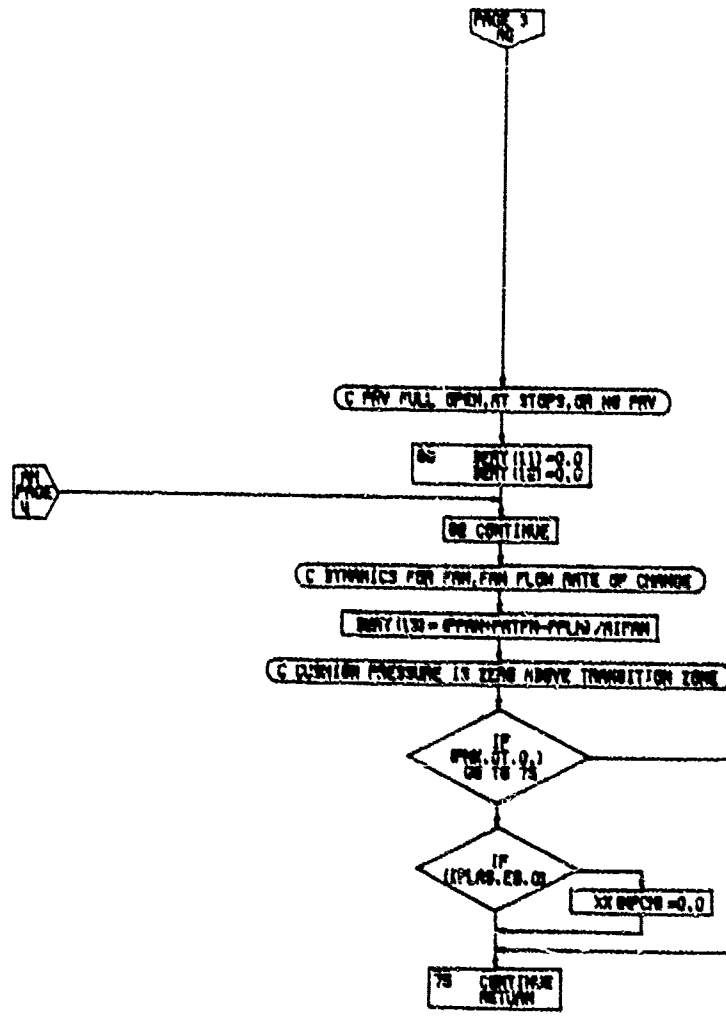

PAGE 3
STEQU

Table 93: FLOWCHART FOR SUBROUTINE SV

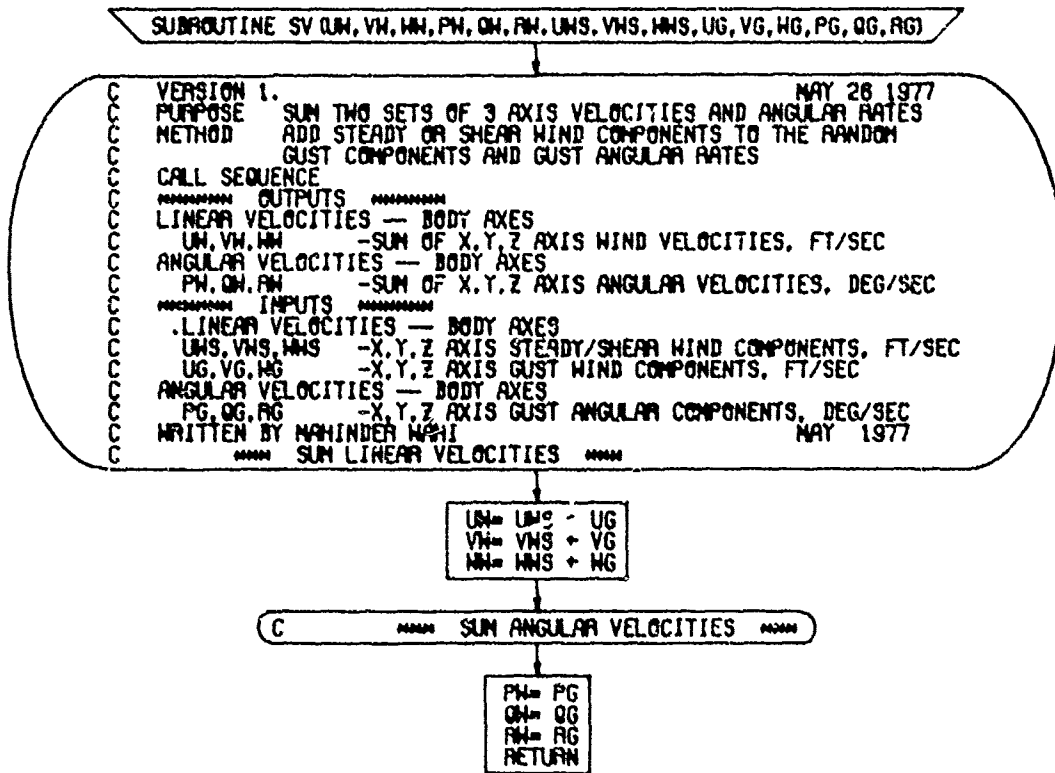

Table 94: FLOWCHART FOR SUBROUTINE SW

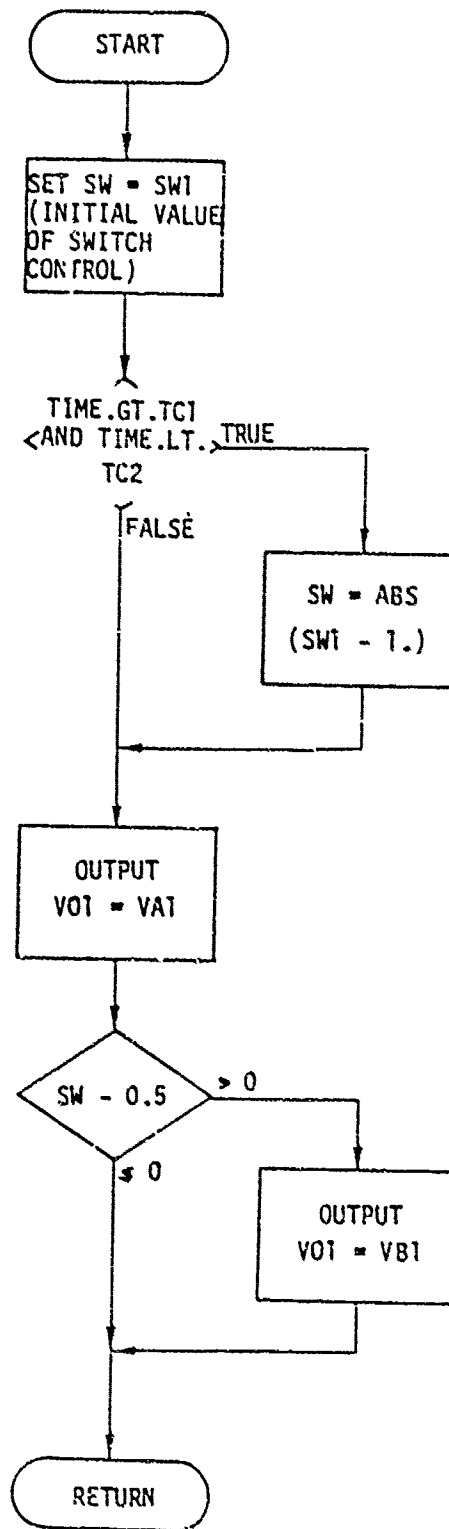

Table 95: FLOWCHART FOR SUBROUTINE SX

SUBROUTINE SX (V01, V02, VA1, VA2, VB1, VB2, SW1, TC1, TC2)

PURPOSE - TO PROVIDE A SWITCH COMPONENT FOR TWO VARIABLES

METHOD - SEE CODING

WRITTEN BY - ADAM LLOYD LATEST REVISION NOV 75

LIMITATIONS - NOT MORE THAN TWO SWITCHINGS AT TIMES TC1 AND TC2

INPUT/OUTPUT LIST

V01	OUTPUT VARIABLE NO 1	ANY	OUTPUT VAR
V02	OUTPUT VARIABLE NO 2	ANY	OUTPUT VAR
VA1	INPUT VARIABLE NO A1	ANY	INPUT VAR
VA2	INPUT VARIABLE NO A2	ANY	INPUT VAR
VB1	INPUT VARIABLE NO B1	ANY	INPUT VAR
VB2	INPUT VARIABLE NO B2	ANY	INPUT VAR
SW1	SWITCH CONTROL INITIAL VALUE	---	INPUT PARAM
	=1. V0=VB		
	=0. V0=VA		
TC1	TIME FOR FIRST SWITCH	SECS	INPUT PARAM
TC2	TIME FOR SECOND SWITCH (TC2.GT.TC1)	SECS	INPUT PARAM

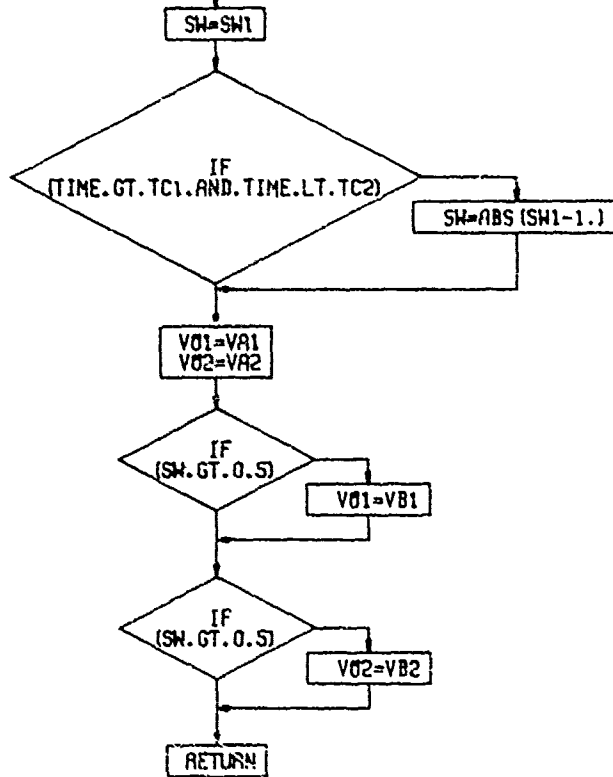

Table 96: FLOWCHART FOR SUBROUTINE SY

SUBROUTINE SY (V01,V02,V03,VA1,VA2,VA3,V01,V02,V03,SM1,TC1,TC2)

PURPOSE - TO PROVIDE A SWITCH COMPONENT FOR THREE VARIABLES

METHOD - SEE CODING

WRITTEN BY - ADAM LLOYD LATEST REVISION NOV 75

LIMITATIONS - NOT MORE THAN TWO SWITCHINGS AT TIMES TC1 AND TC2

INPUT/OUTPUT LIST

V01	OUTPUT VARIABLE NO 1	ANY	OUTPUT VAR
V02	OUTPUT VARIABLE NO 2	ANY	OUTPUT VAR
V03	OUTPUT VARIABLE NO 3	ANY	OUTPUT VAR
VA1	INPUT VARIABLE NO A1	ANY	INPUT VAR
VA2	INPUT VARIABLE NO A2	ANY	INPUT VAR
VA3	INPUT VARIABLE NO A3	ANY	INPUT VAR
V01	INPUT VARIABLE NO B1	ANY	INPUT VAR
V02	INPUT VARIABLE NO B2	ANY	INPUT VAR
V03	INPUT VARIABLE NO B3	ANY	INPUT VAR
SM1	SWITCH CONTROL INITIAL VALUE	---	INPUT PARAM
	=1. V0=VB		
	=0. V0=VA		

TC1	TIME FOR FIRST SWITCH	SECS	INPUT	PARAM
TC2	TIME FOR SECOND SWITCH (TC2.GT.TC1)	SECS	INPUT	PARAM

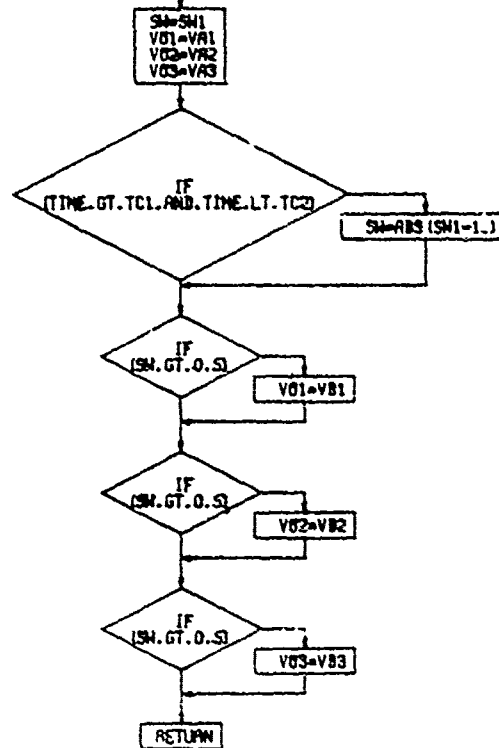

Table 97: FLOWCHART FOR SUBROUTINE SZ

SUBROUTINE SZ (V01, V02, V03, V04, V01, V02, V03, V04, V01, V02, V03, V04,
I SM1, TC1, TC2)

PURPOSE - TO PROVIDE A SWITCH COMPONENT FOR FOUR VARIABLES

METHOD - SEE CODING

WRITTEN BY - ADAM LLOYD

LATEST REVISION NOV 75

LIMITATIONS - NOT MORE THAN TWO SWITCHINGS AT TIMES TC1 AND TC2

INPUT/OUTPUT LIST

V01	OUTPUT VARIABLE NO 1	ANY	OUTPUT VAR
V02	OUTPUT VARIABLE NO 2	ANY	OUTPUT VAR
V03	OUTPUT VARIABLE NO 3	ANY	OUTPUT VAR
V04	OUTPUT VARIABLE NO 4	ANY	OUTPUT VAR
V01	INPUT VARIABLE NO 01	ANY	INPUT VAR
V02	INPUT VARIABLE NO 02	ANY	INPUT VAR
V03	INPUT VARIABLE NO 03	ANY	INPUT VAR
V04	INPUT VARIABLE NO 04	ANY	INPUT VAR
V01	INPUT VARIABLE NO 01	ANY	INPUT VAR
V02	INPUT VARIABLE NO 02	ANY	INPUT VAR
V03	INPUT VARIABLE NO 03	ANY	INPUT VAR
V04	INPUT VARIABLE NO 04	ANY	INPUT VAR

SM1	SWITCH CONTROL INITIAL VALUE =1. V0=V3 =0. V0=V4	—	INPUT PARAM
TC1	TIME FOR FIRST SWITCH	SECS	INPUT PARAM
TC2	TIME FOR SECOND SWITCH (TC2.GT. TC1)	SECS	INPUT PARAM

SM=SM1

IF
(TIME.GT. TC1.AND. TIME.LT. TC2)

SM=ABS (SM1-1.)

V01=V01
V02=V02
V03=V03
V04=V04

PAGE 2
OF

PAGE 1
52

Table 97: FLOWCHART FOR SUBROUTINE SZ (CONCLUDED)

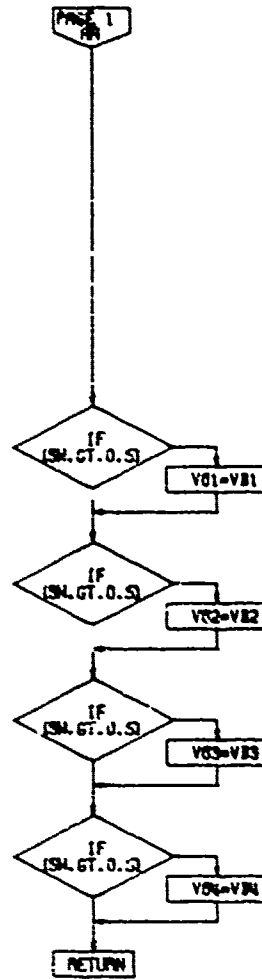

Table 99: FLOWCHART FOR SUBROUTINE S3

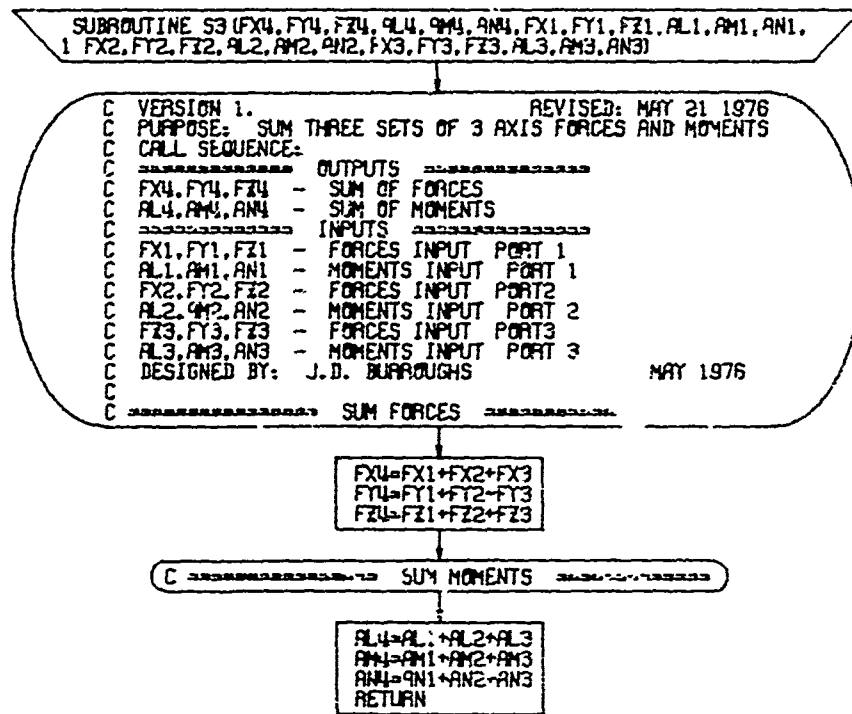

Table 100: FLOWCHART FOR SUBROUTINE TA

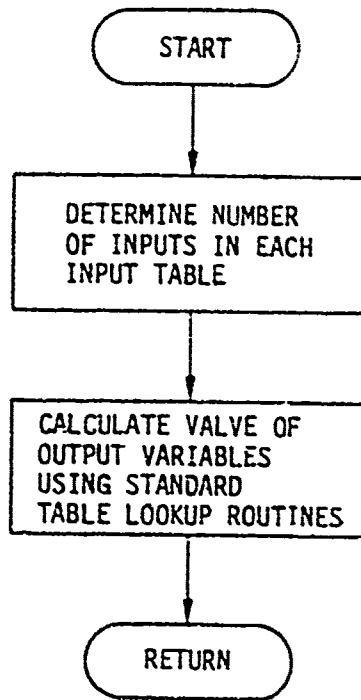

Table 101: FLOWCHART FOR SUBROUTINE TB

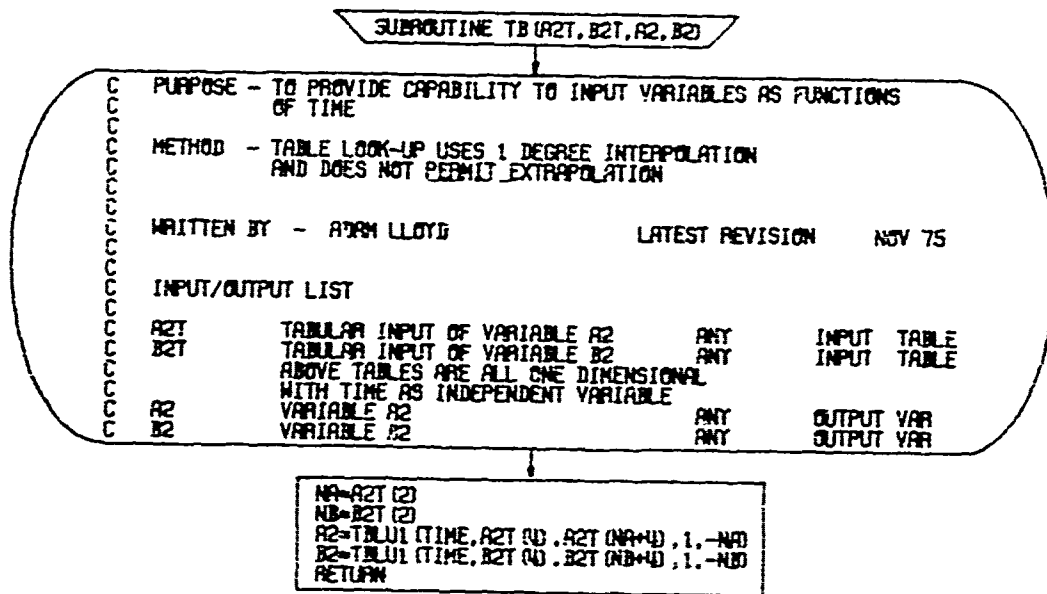

Table 102: FLOWCHART FOR SUBROUTINE TBL1

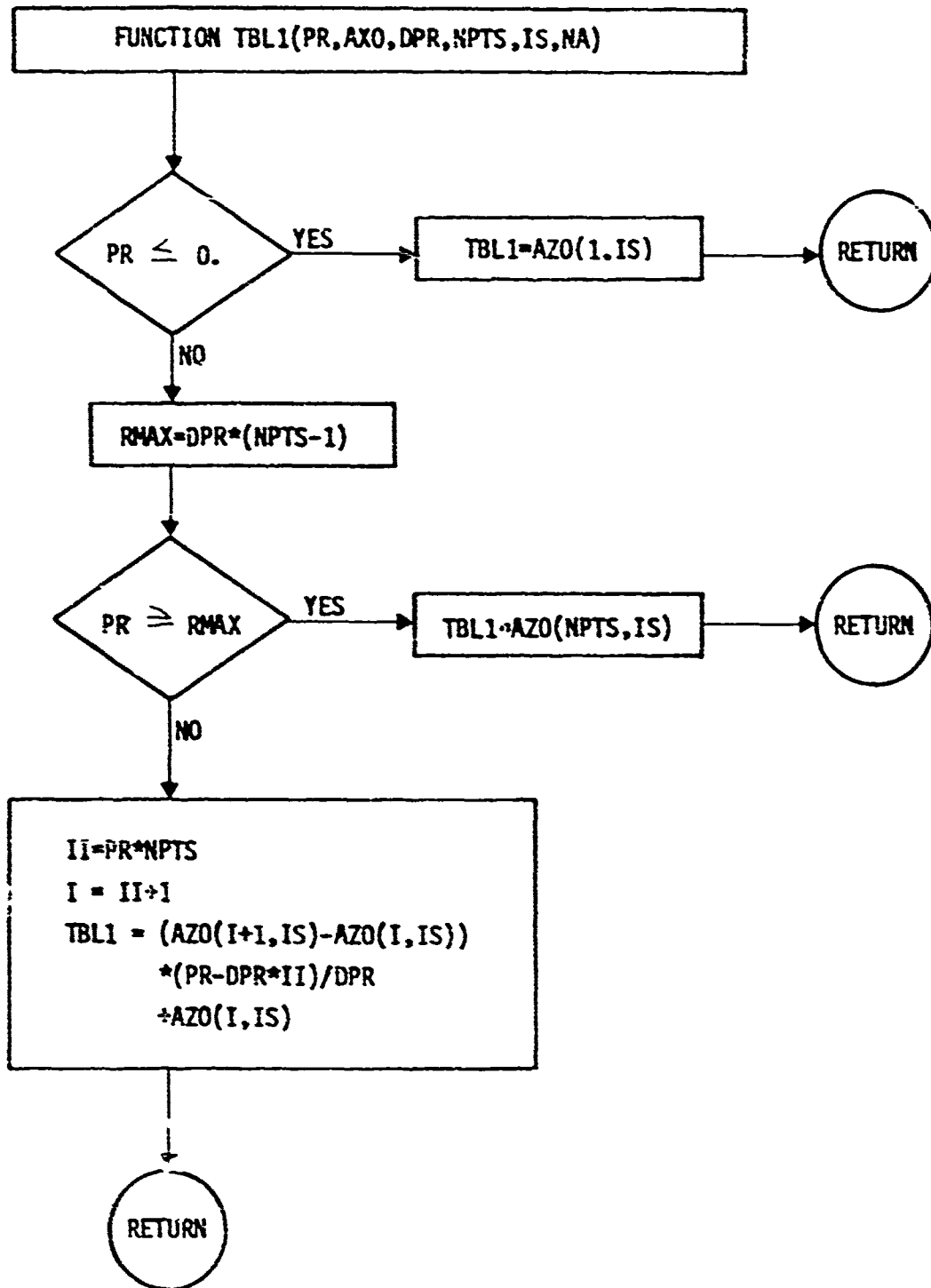

Table 103: FLOWCHART FOR SUBROUTINE TBL2

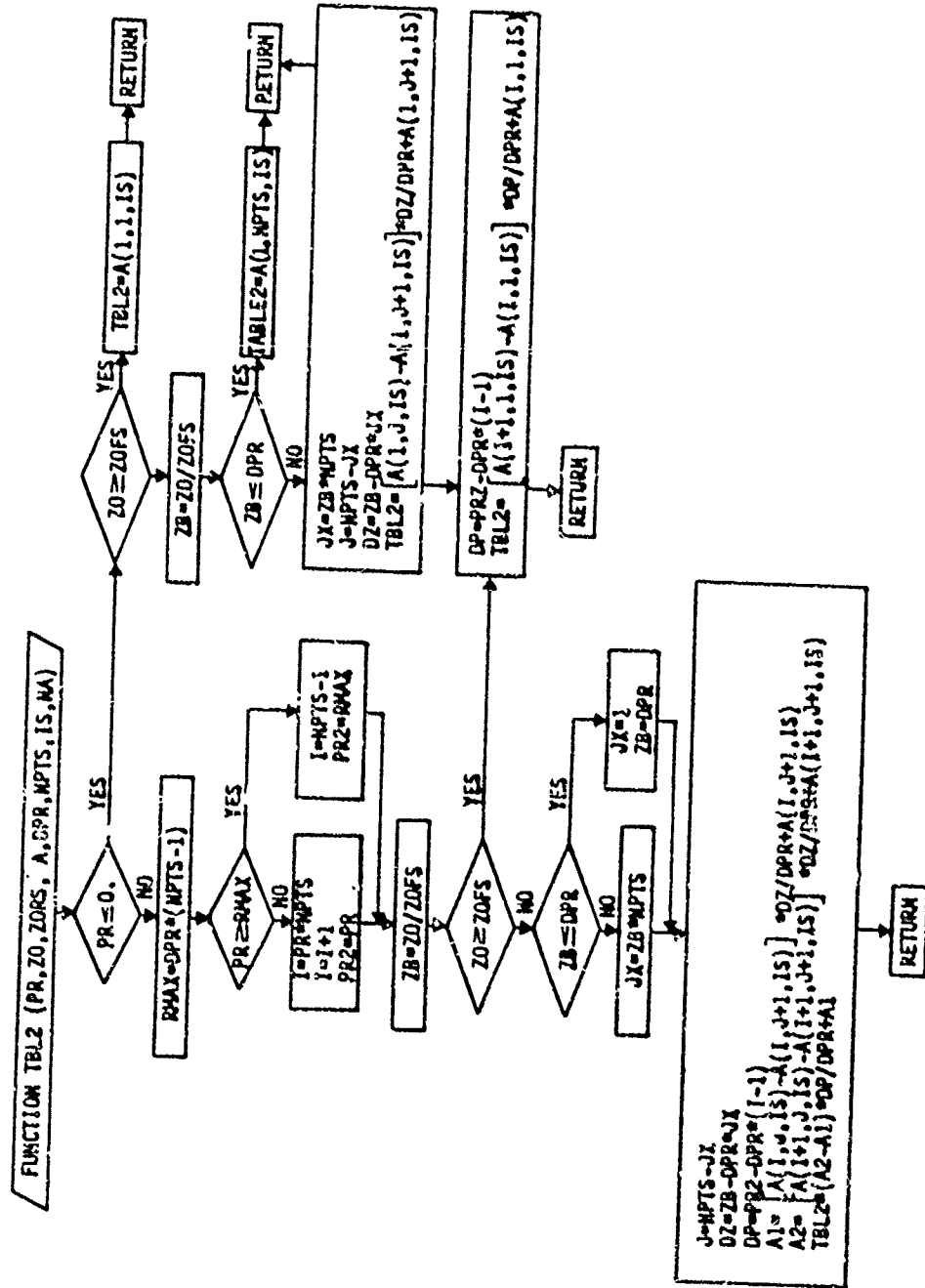

Table 104: FLOWCHART FOR SUBROUTINE TBLU1

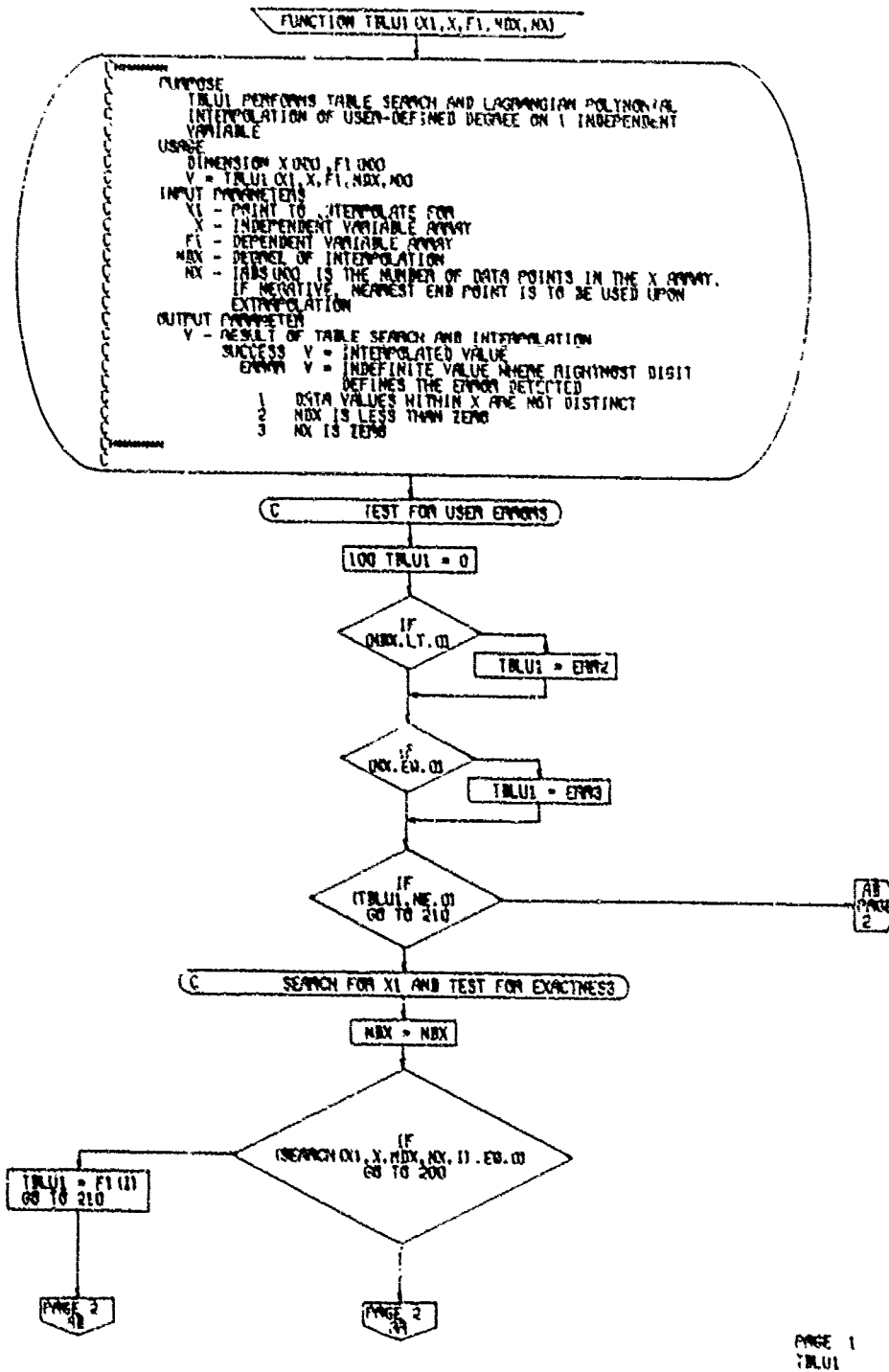

Table 104: FLOWCHART FOR SUBROUTINE TBLU1 (CONCLUDED)

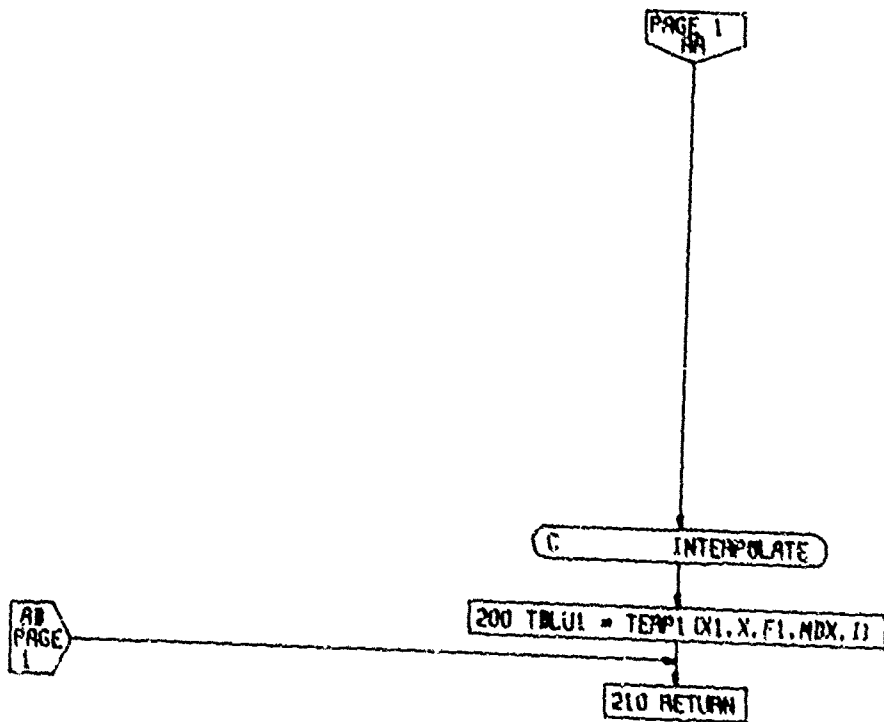

Table 105: FLOWCHART FOR SUBROUTINE TBLU2

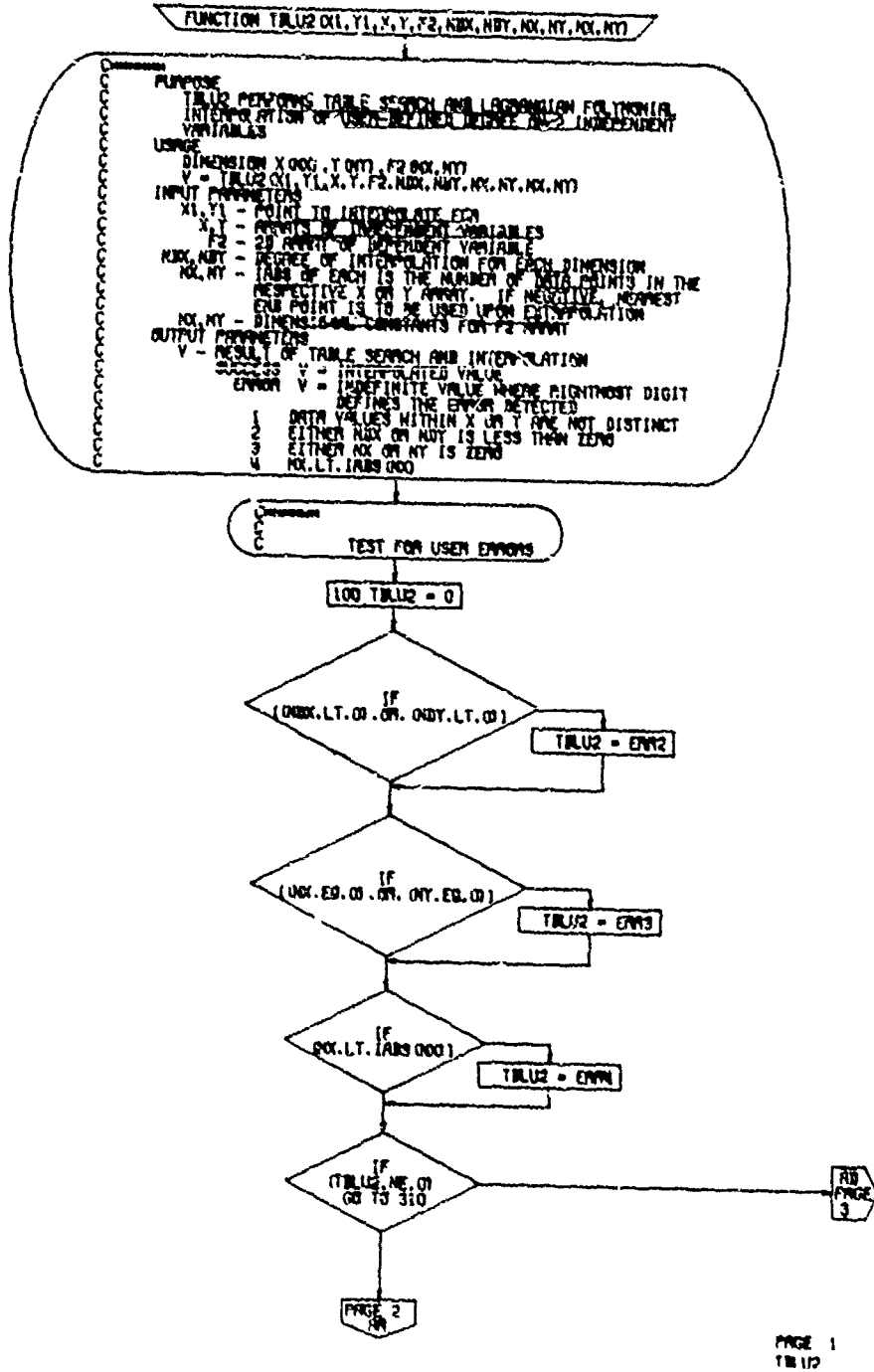
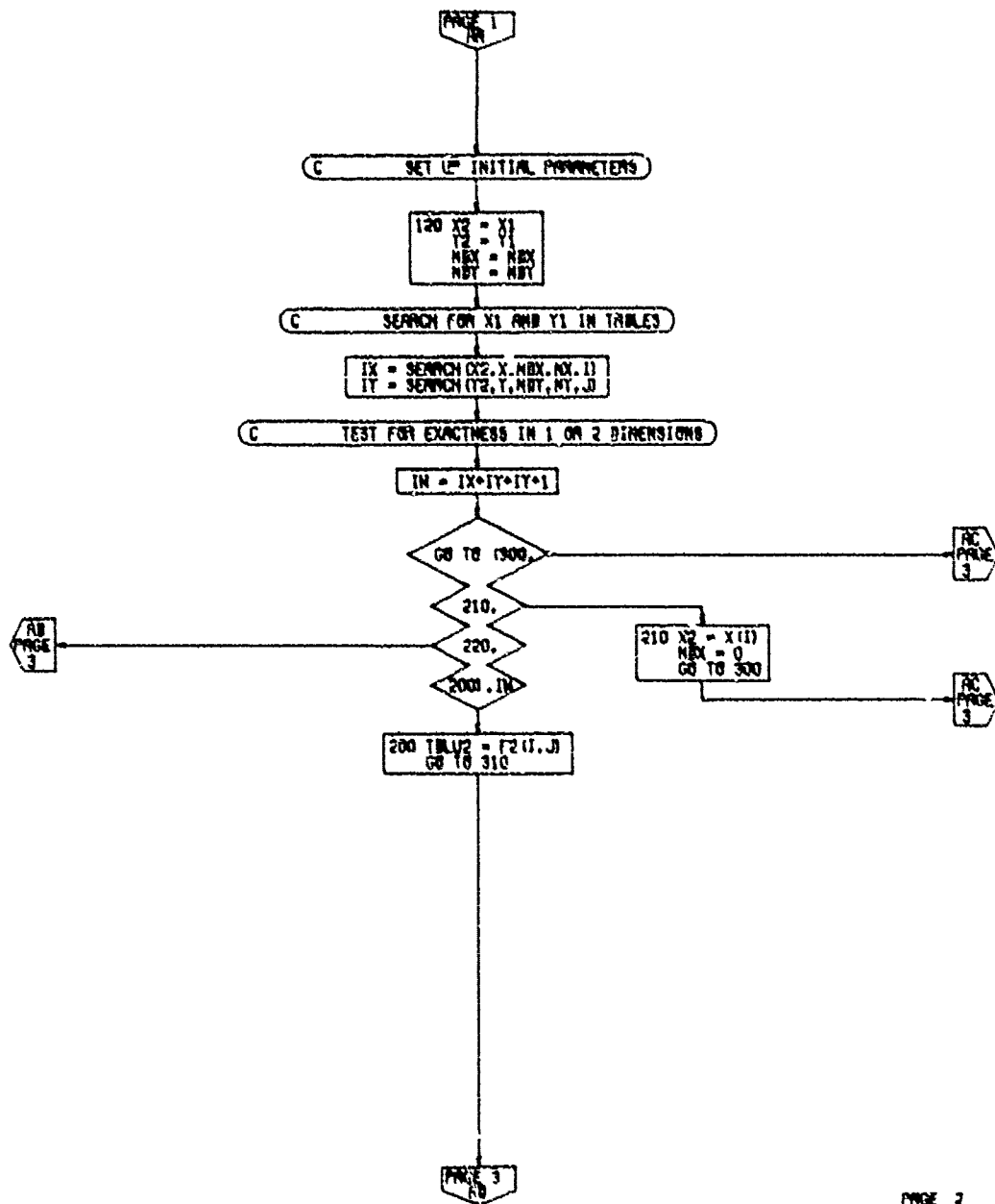
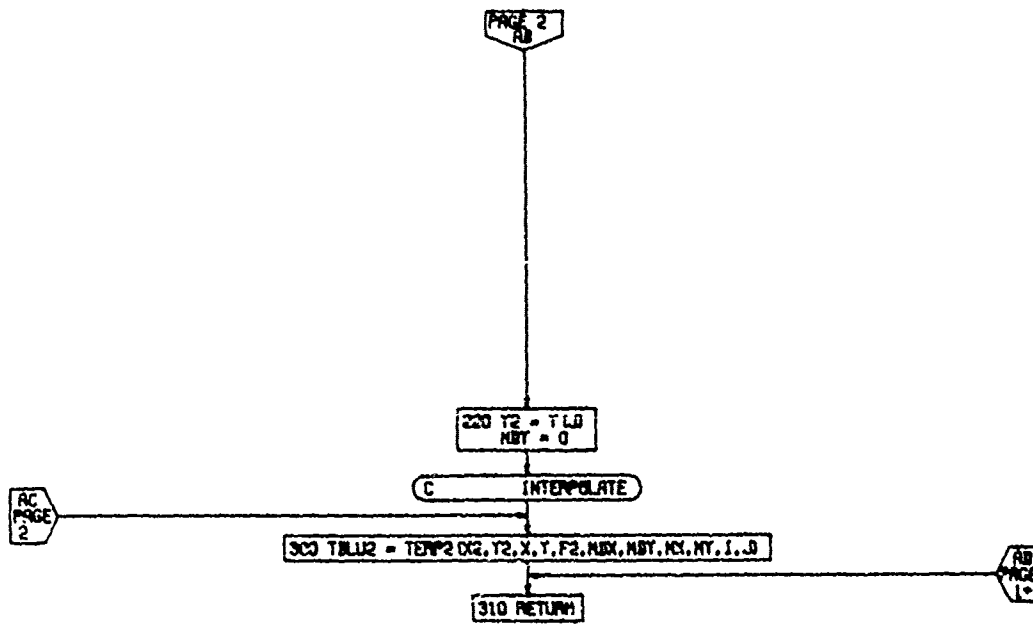

Table 105: FLOWCHART FOR SUBROUTINE TBLU2 (CONTINUED)



PAGE 2
TBLU2

Table 105: FLOWCHART FOR SUBROUTINE TBLU2 (CONCLUDED)



PAGE 3
TBLU2

Table 106: FLOWCHART FOR SUBROUTINE TBLU3

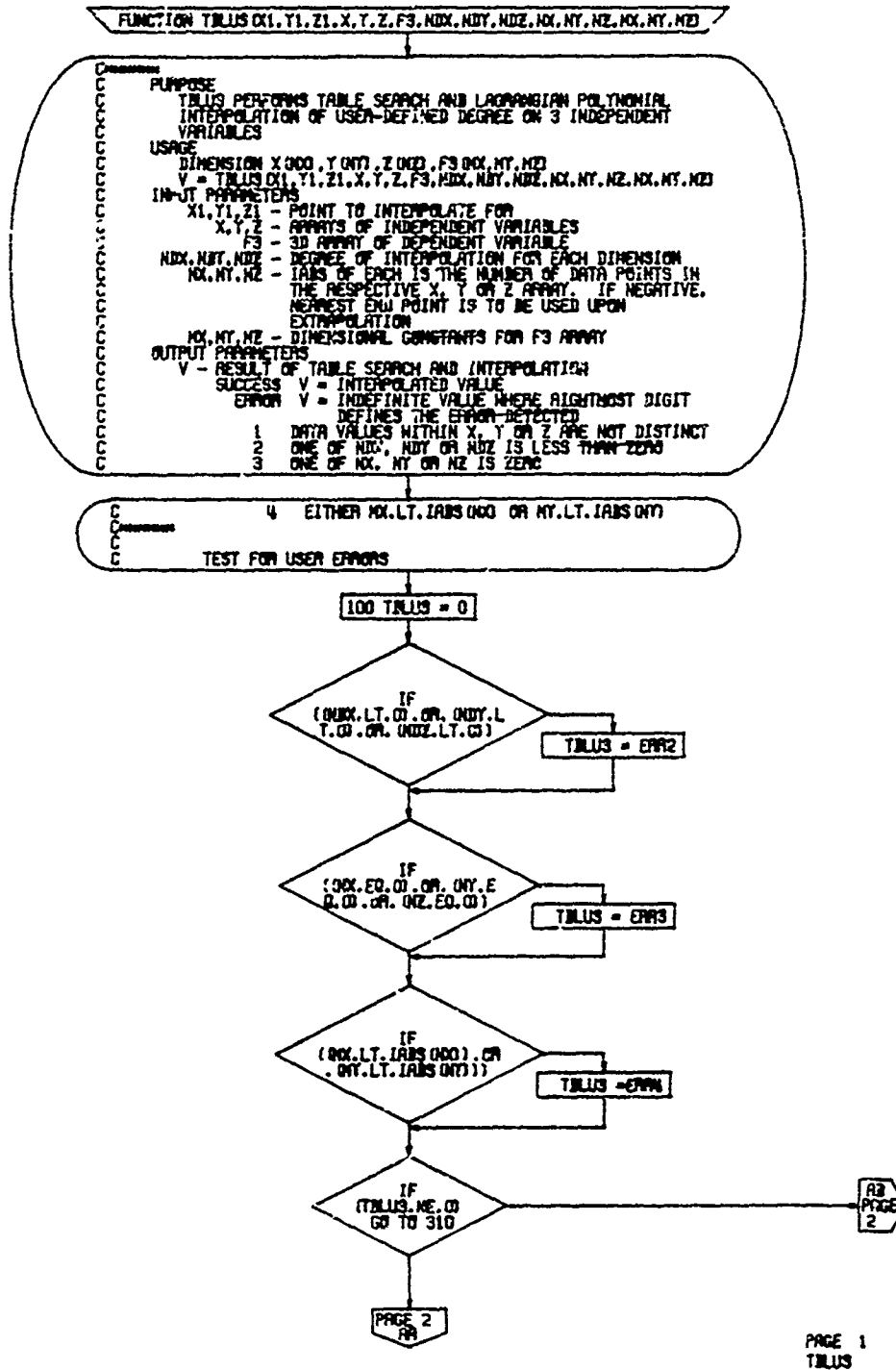
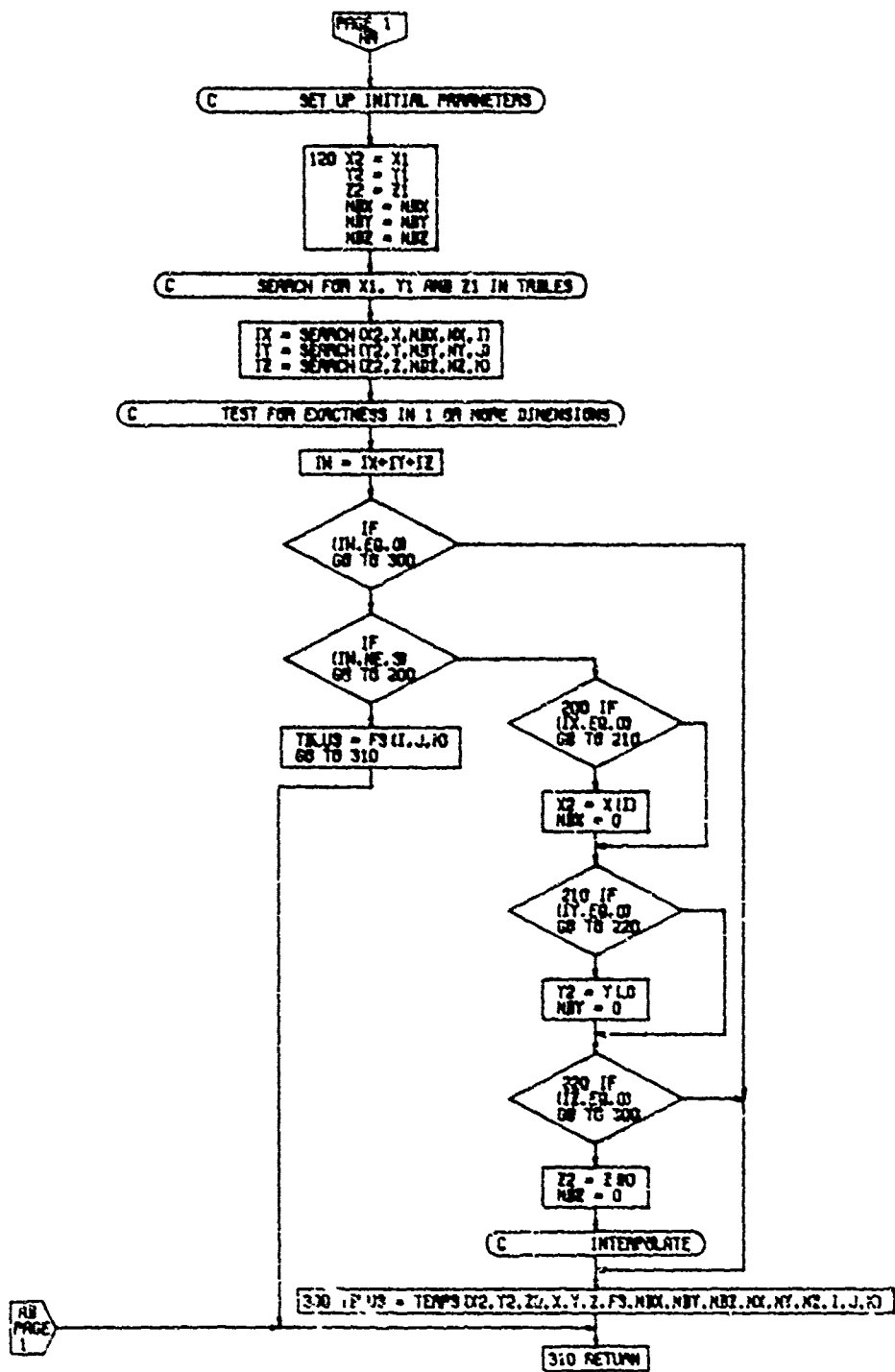

Table 106: FLOWCHART FOR SUBROUTINE TBLU3 (CONCLUDED)



PAGE 2
TBLU3

Table 107: FLOWCHART FOR SUBROUTINE TD

SUBROUTINE TD (V, VB, IV, P, PB, IP, R, RB, IR, AOL, AOB, IROL, IOB, IYAM, YAMB, IYAM, YB, PROT, ADOT, VDOT, TX, TZ, XXI, ZZI, XZI, PIT)

VERSION 1. APRIL 27, 1977
 PURPOSE THREE DEGREE OF FREEDOM RIGID BODY EQUATIONS OF MOTION (LATTI)
 METHOD EULER ANGLES
 CALL SEQUENCE
 OUTPUTS
 LINEAR VELOCITIES -- BODY AXES
 V, VB, IV -- Y AXIS LINEAR VELOCITY, ACCEL, INT CONTROL, FT/SEC
 ANGULAR VELOCITIES -- BODY AXES
 P, PB, IP -- X AXIS ANGULAR VELOCITY, ACCEL, INT CONTROL, DEG/SEC
 R, RB, IR -- Z AXIS ANGULAR VELOCITY, ACCEL, INT CONTROL, DEG/SEC
 EULER ANGLES -- EARTH TO BODY -- YAW, PITCH, ROLL
 AOL, AOB, IROL -- ROLL ANGLE, RATE, INT CONTROL, DEG
 YAM, YAMB, IYAM -- YAW ANGLE, RATE, INT CONTROL, DEG
 POSITION -- EARTH AXES
 TD -- Y AXIS LINEAR VELOCITY, FT/SEC
 ANGULAR ACCELERATION -- BODY AXES
 PDOT -- X AXIS ANGULAR ACCELERATION, DEG/SEC²
 ADOT -- Z AXIS ANGULAR ACCELERATION, DEG/SEC²
 INPUTS
 LINEAR ACCELERATION -- BODY AXES
 VDOT -- Y AXIS LINEAR ACCELERATION, FT/SEC²
 MOMENTS
 TX, TZ -- X, Z AXIS TORQUES, FT-LBS
 MOMENTS OF INERTIA
 XXI, ZZI -- X, Z AXIS MOMENTS OF INERTIA, SLUG-FT²
 XZI -- PRODUCT OF INERTIA, SLUG-FT²

EULER ANGLE -- EARTH TO BODY -- PITCH
 PIT -- PITCH ANGLE, DEG
 WRITTEN BY H.K. WANI MARCH 1977

CP=COS PIT-APPB
 SP=SIN PIT-APPB
 CR=COS IROL-APPB
 SR=SIN IROL-APPB

LINEAR VELOCITY EQUATIONS

IF (IV.NE.0)
 VB=VDOT

ANGULAR VELOCITY EQUATIONS

IF (OZI.NE.0..AND..XZI.NE..99999)
 GO TO 100

AD
 PAGE 1

PAGE 2

PAGE 1
 TD

Table 107: FLOWCHART FOR SUBROUTINE TD (CONTINUED)

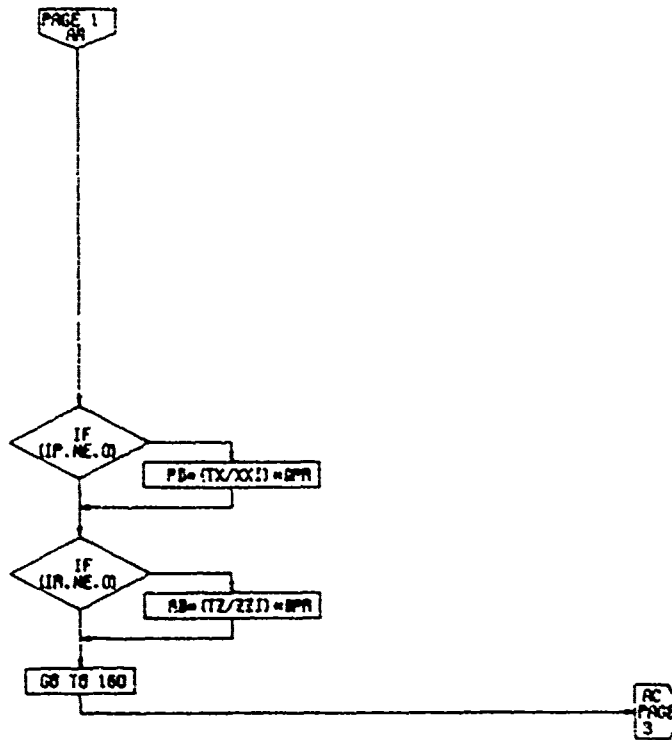

Table 107: FLOWCHART FOR SUBROUTINE TD (CONCLUDED)

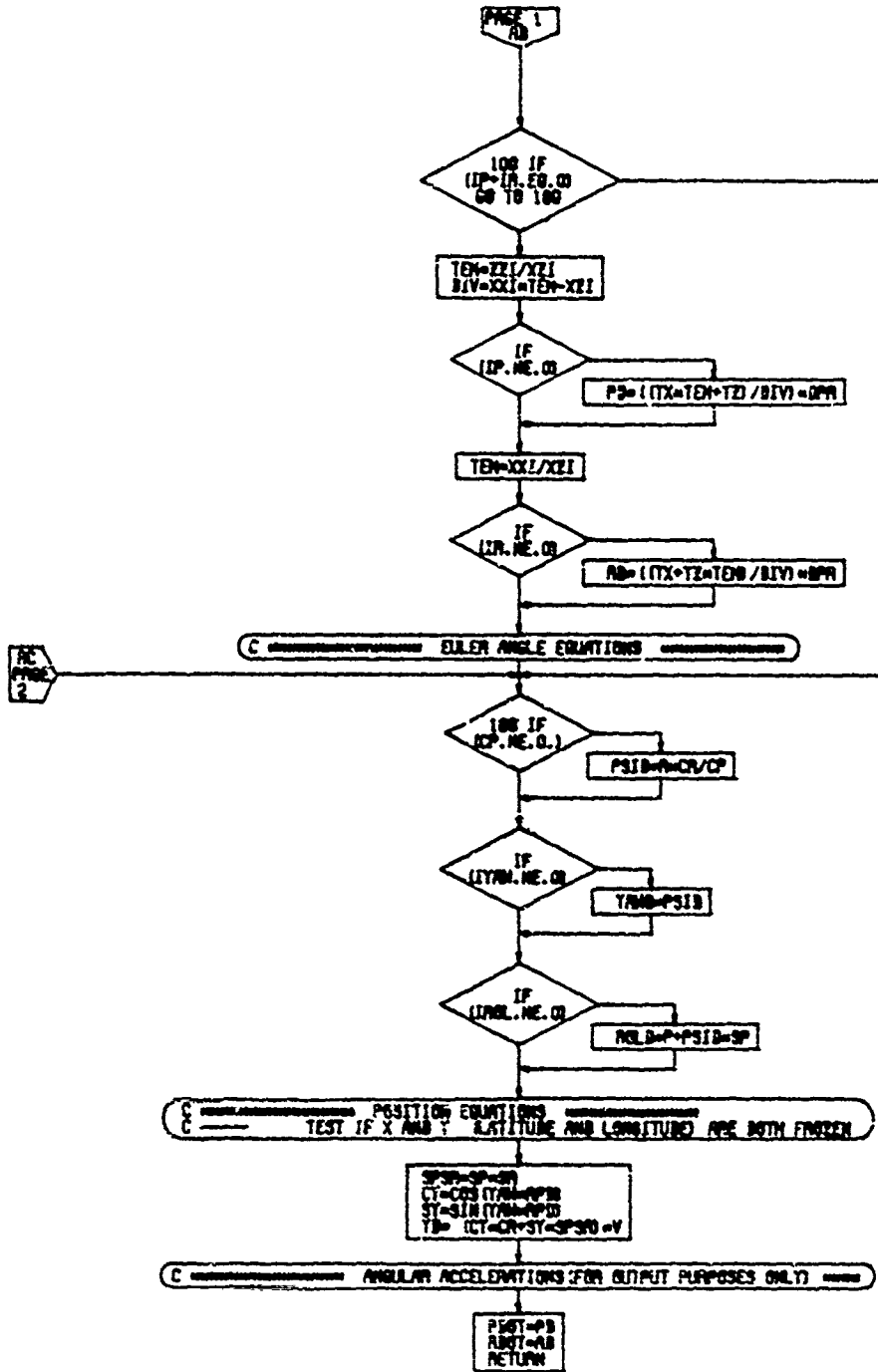

Table 108: FLOWCHART FOR SUBROUTINE TERRA

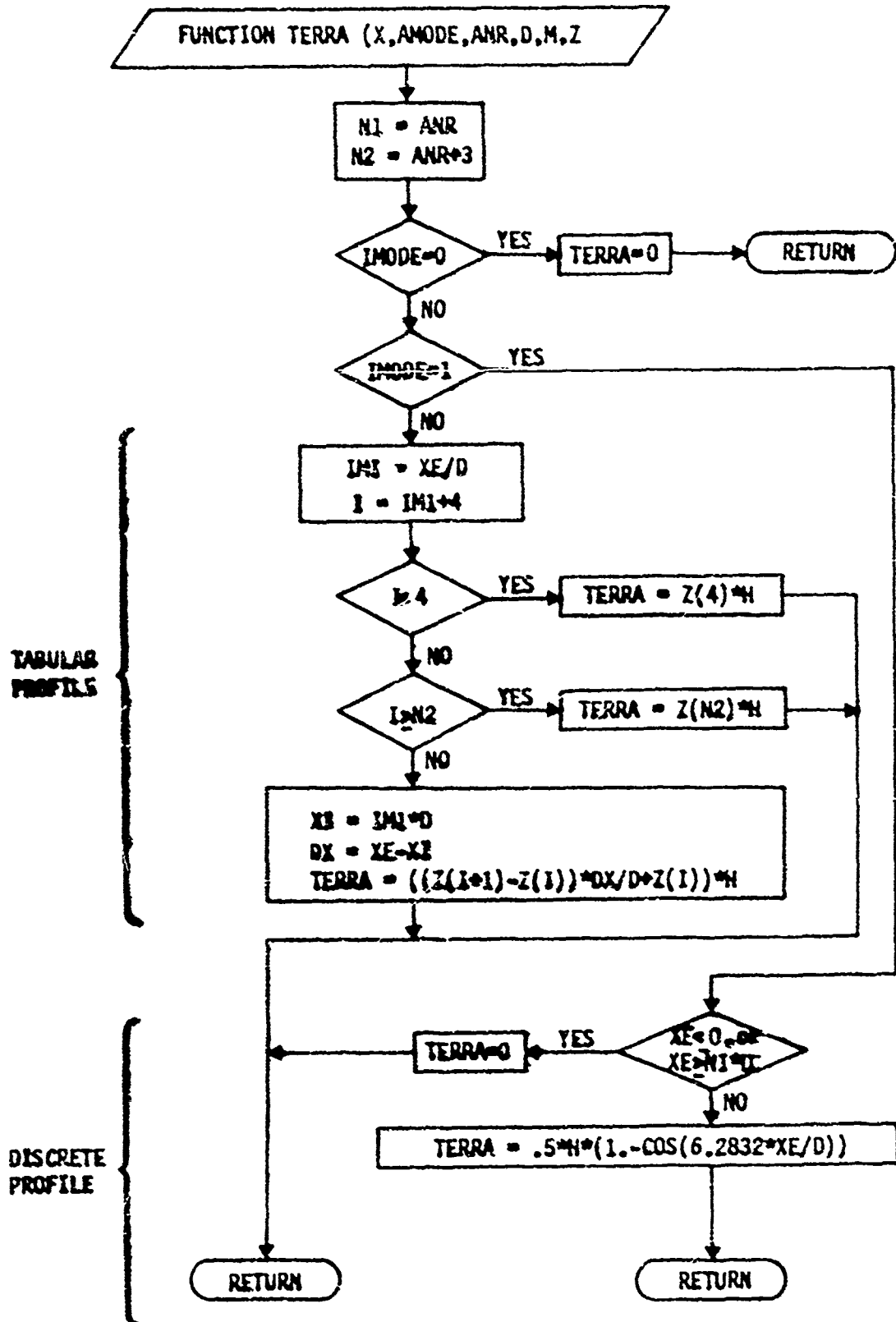

Table 109: FLOWCHART FOR SUBROUTINE TF

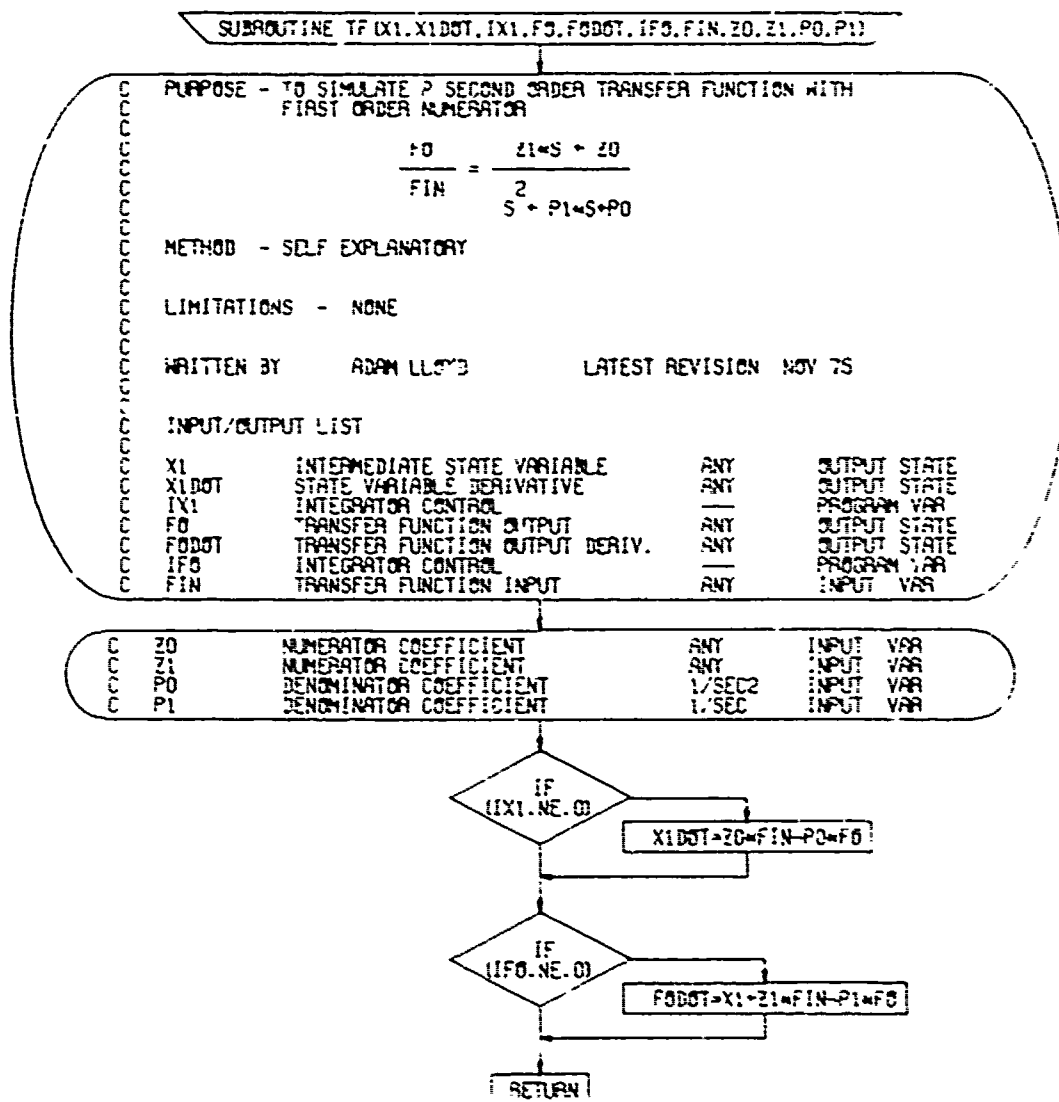

Table 110: FLOWCHART FOR SUBROUTINE TG

SUBROUTINE TG (FX, FY, FZ, TX, TY, TZ, TH, GAMX, GAMY, GAMZ, XO, YO, ZO)

```

C  VERSION 1.                                REVISED: SEPT 20 1976
C  PURPOSE:  TRANSFORM ENGINE THRUST INTO BODY AXIS FORCES AND
C            TORQUES
C  CALL SEQUENCE:
C  ***** OUTPUTS *****
C  FX, FY, FZ  -X, Y, Z AXIS FORCES ABOUT C.G., LBS
C  TX, TY, TZ  -X, Y, Z AXIS TORQUES, FT-LBS
C  ***** INPUTS *****
C  TH          -ENGINE THRUST IN LBS
C  GAMX, GAMY, GAMZ -X, Y, Z AXIS DIRECTION COSINES
C  XO, YO, ZO  - THRUST LOCATION COMPONENTS, FT
C  DESIGNED BY A.W. WARREN                                SEPT. 1976
    
```

```

FX= TH*GX
FY= TH*GY
FZ= TH*GZ
TX= ZO*FX - XO*FZ
TY= ZO*FY - XO*FZ
TZ= XO*FY - YO*FX
RETURN
    
```

Table 111: FLOWCHART FOR SUBROUTINE TK

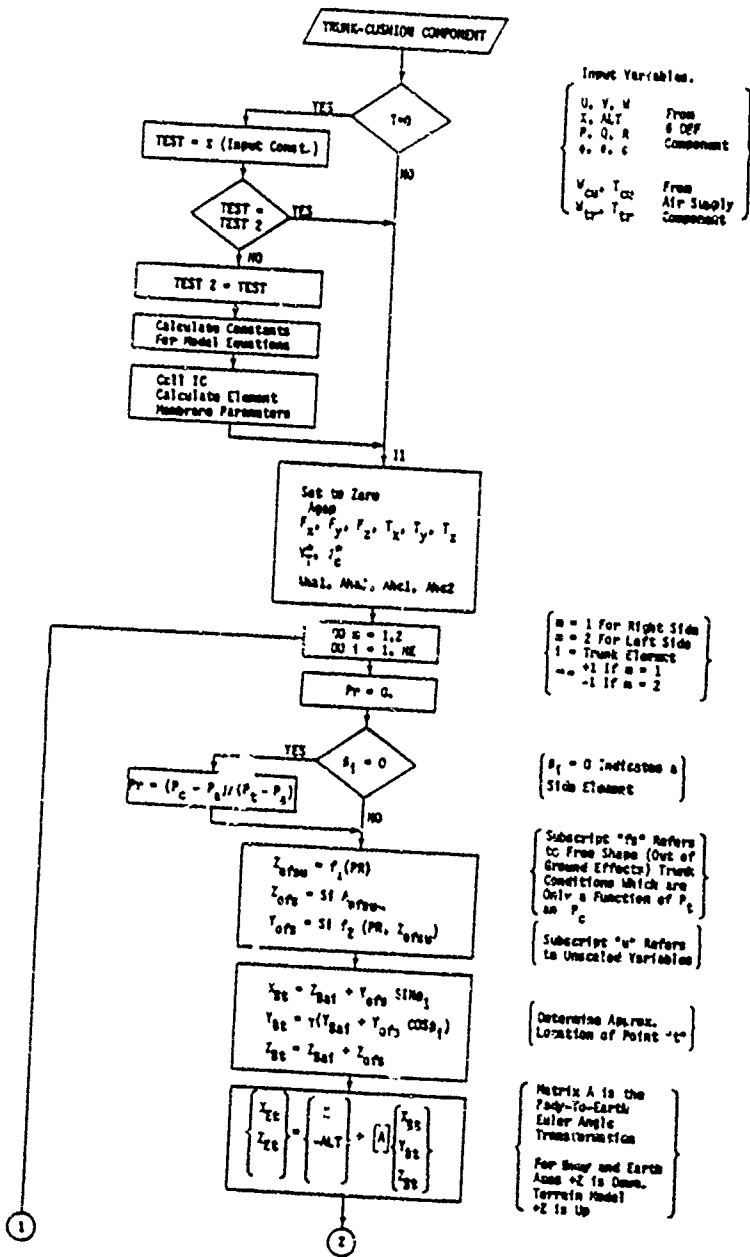
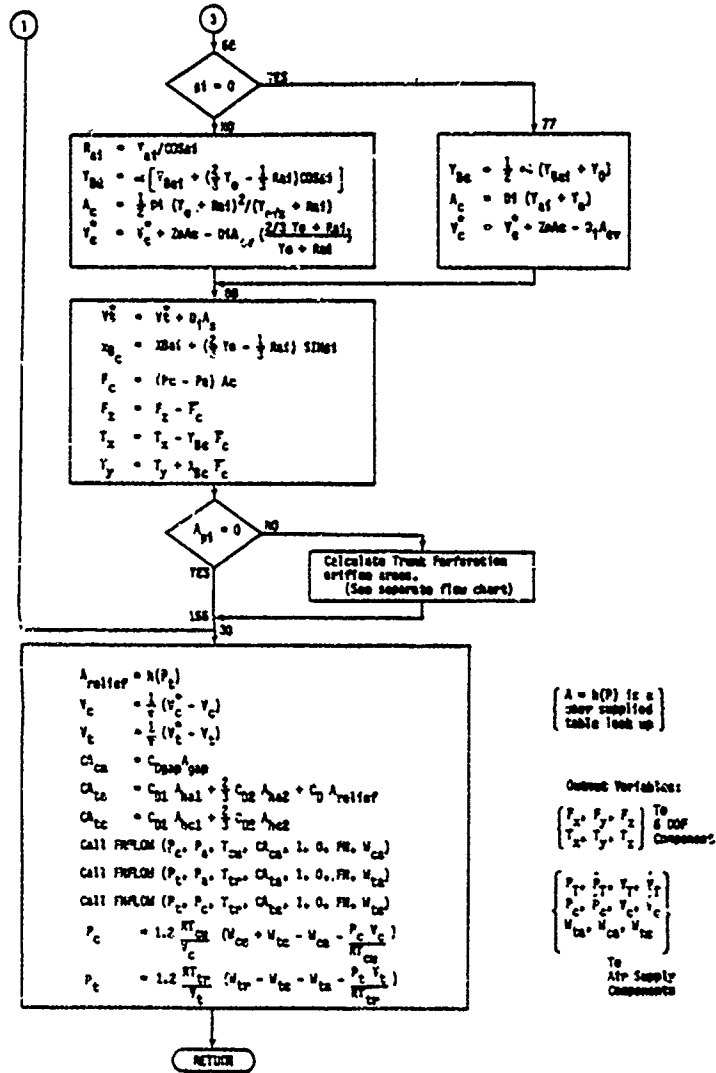

Table 111: FLOWCHART FOR SUBROUTINE TK (CONCLUDED)



$A = A(P)$ is a
other supplied
table look up

Output Variables:
 $\begin{Bmatrix} F_x \\ F_y \\ F_z \\ T_x \\ T_y \\ T_z \end{Bmatrix}$ To
 & DOF
 Component

$\begin{Bmatrix} P_{cr} \\ P_c \\ M_{cr} \\ M_{ca} \\ M_{bc} \end{Bmatrix}$
 To Air Supply
 Components

Table 112: FLOWCHART FOR SUBROUTINE TL

SUBROUTINE TL U,UB,IU,W,WB,IN,Q,QB,IQ,PIT,PITB,IPIT,XB,
I,Z,ZB,IZ,QDOT,UODT,WODT,TY,YYI,ROL,YAO

VERSION 1. APRIL 20, 1977.
 PURPOSE THREE DEGREE OF FREEDOM RIGID BODY EQUATIONS OF MOTION (LOW
 METHOD EULER ANGLES
 CALL SEQUENCE
 OUTPUTS
 LINEAR VELOCITIES -- BODY AXES
 U,UB,IU - X AXIS LINEAR VELOCITY, ACCEL., INT CONTROL, FT/SEC
 W,WB,IN - Y AXIS LINEAR VELOCITY, ACCEL., INT CONTROL, FT/SEC
 ANGULAR VELOCITIES -- BODY AXES
 Q,QB,IQ - Y AXIS ANGULAR VELOCITY, ACCEL., INT CONTROL, DEG/SEC
 EULER ANGLE -- EARTH TO BODY - PITCH
 PIT,PITB,IPIT - PITCH ANGLE, RATE, INT CONTROL, DEG
 POSITION -- EARTH AXES
 XB - X AXIS LINEAR VELOCITY, FT/SEC
 I,Z,ZB,IZ - Z AXIS POSITION (ALTD), VELOCITY, INT CONTROL, FT
 ANGULAR ACCELERATION -- BODY AXES
 QDOT - Y AXIS ANGULAR ACCELERATION, DEG/SEC2
 INPUTS
 LINEAR ACCELERATIONS -- BODY AXES
 UODT - X AXIS LINEAR ACCELERATION, FT/SEC2
 WODT - Z AXIS LINEAR ACCELERATION, FT/SEC2
 MOMENTS
 TY - Y AXIS TORQUE, FT/LBS
 MOMENT OF INERTIA
 YYI - Y AXIS MOMENTS OF INERTIA, SLUG-FT2
 EULER ANGLES -- EARTH TO BODY - ROLL, YAW

ROL - ROLL ANGLE, DEG
 YAW - YAW ANGLE, DEG
 WRITTEN BY MANINDER NAMI APRIL 1977

CP=COS OF IT-WP
 SP=SIN OF IT-WP
 CP=COS OF RL-WP
 SP=SIN OF RL-WP
 QI-Q-PPD

PAGE 2

PAGE 1
 TL

Table 112: FLOWCHART FOR SUBROUTINE TL (CONCLUDED)

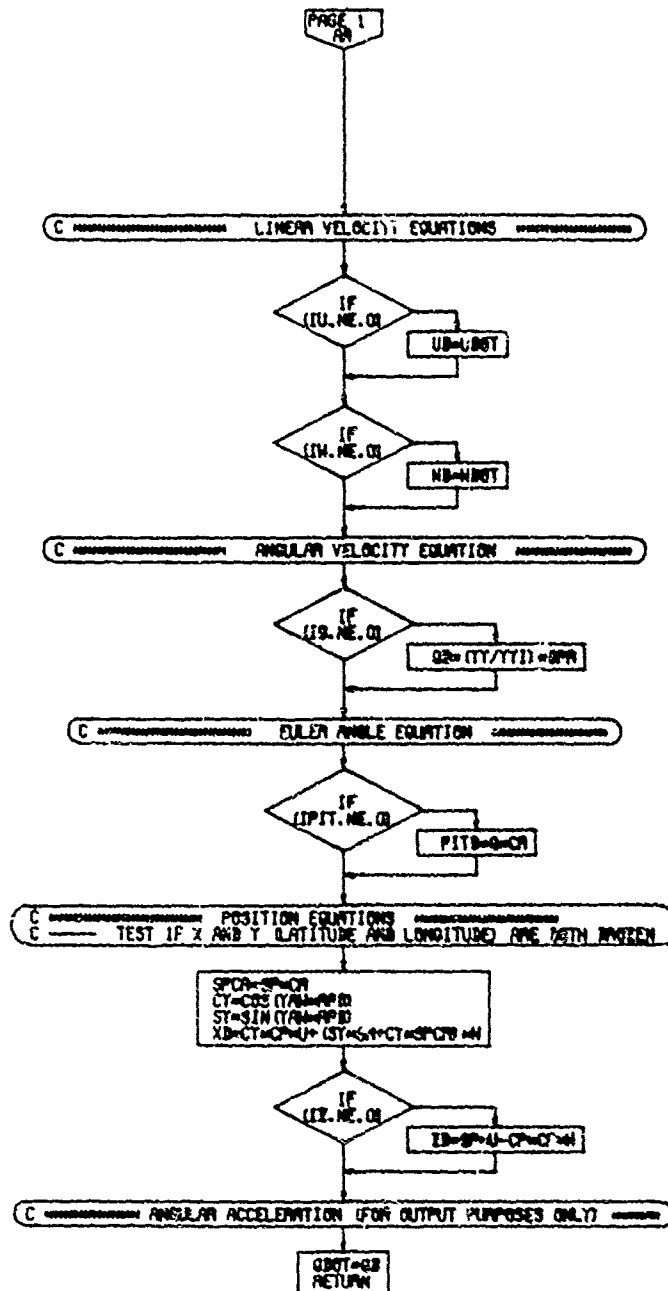

Table 113: FLOWCHART FOR SUBROUTINE TR

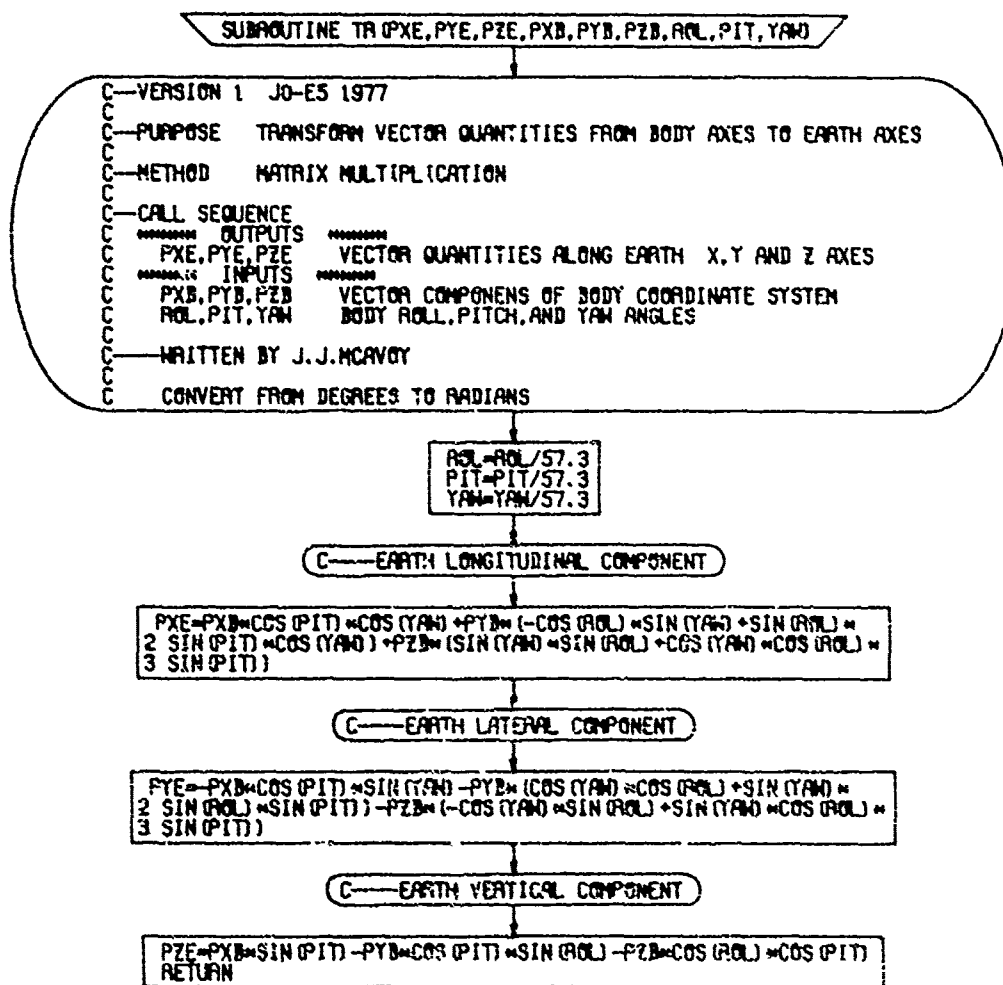
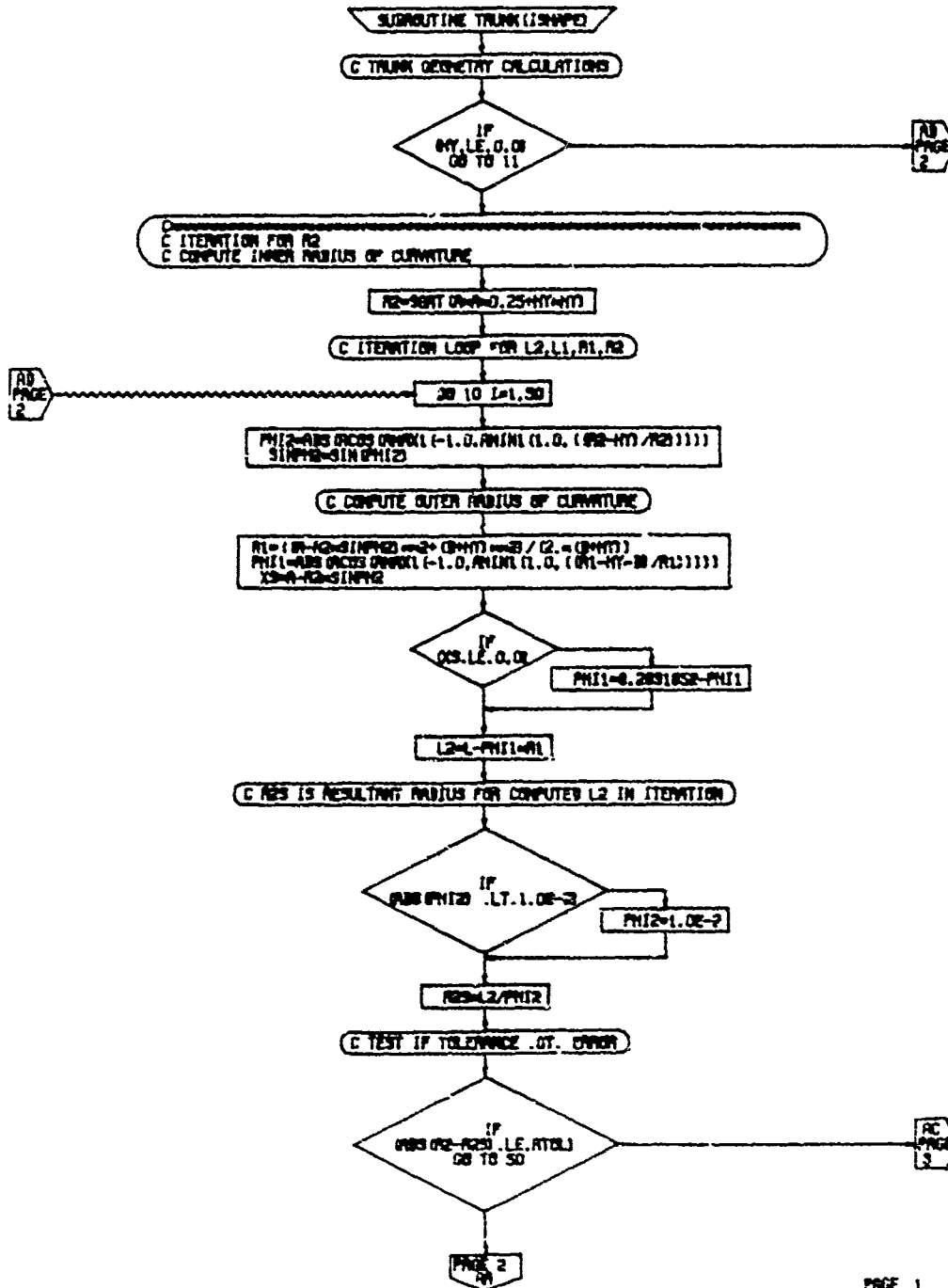
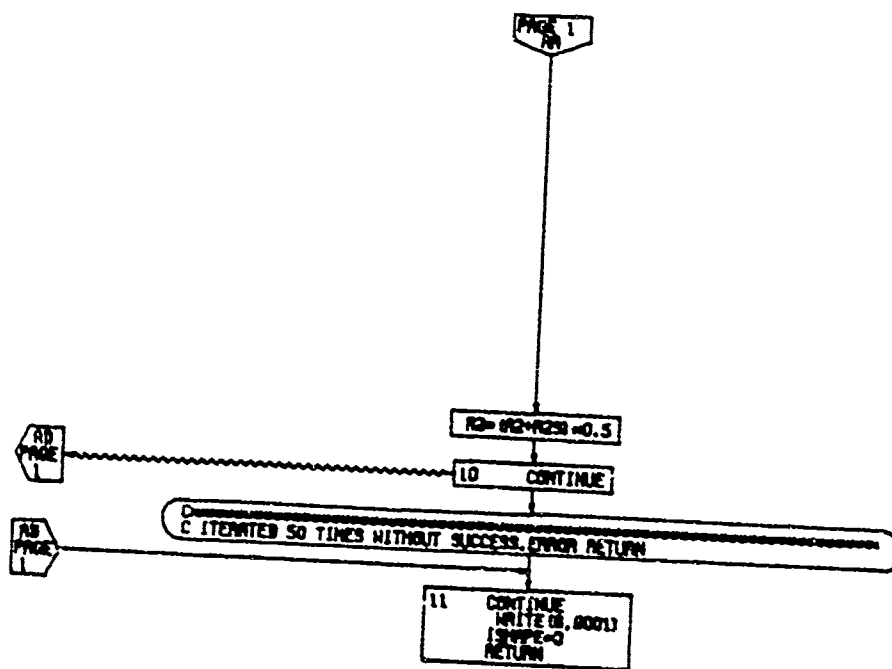

Table 114: FLOWCHART FOR SUBROUTINE TRUNK



PAGE 1
TRUNK

Table 114: FLOWCHART FOR SUBROUTINE TRUNK (CONTINUED)



PAGE 2
TRUNK

Table 114: FLOWCHART FOR SUBROUTINE TRUNK (CONCLUDED)

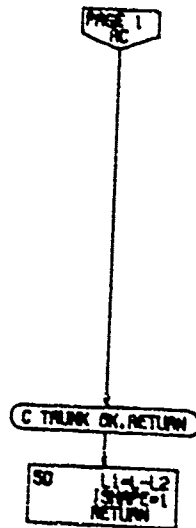
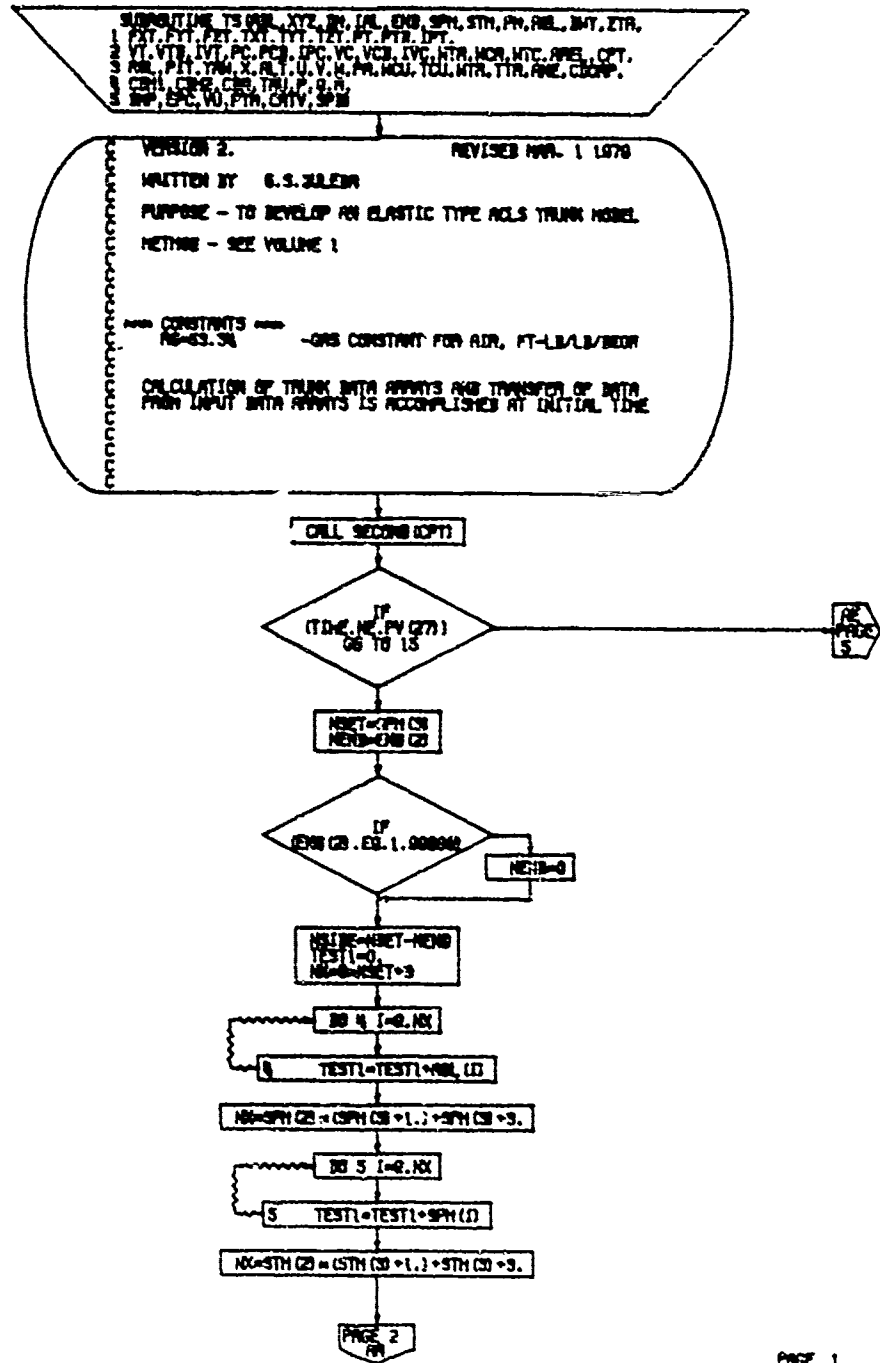
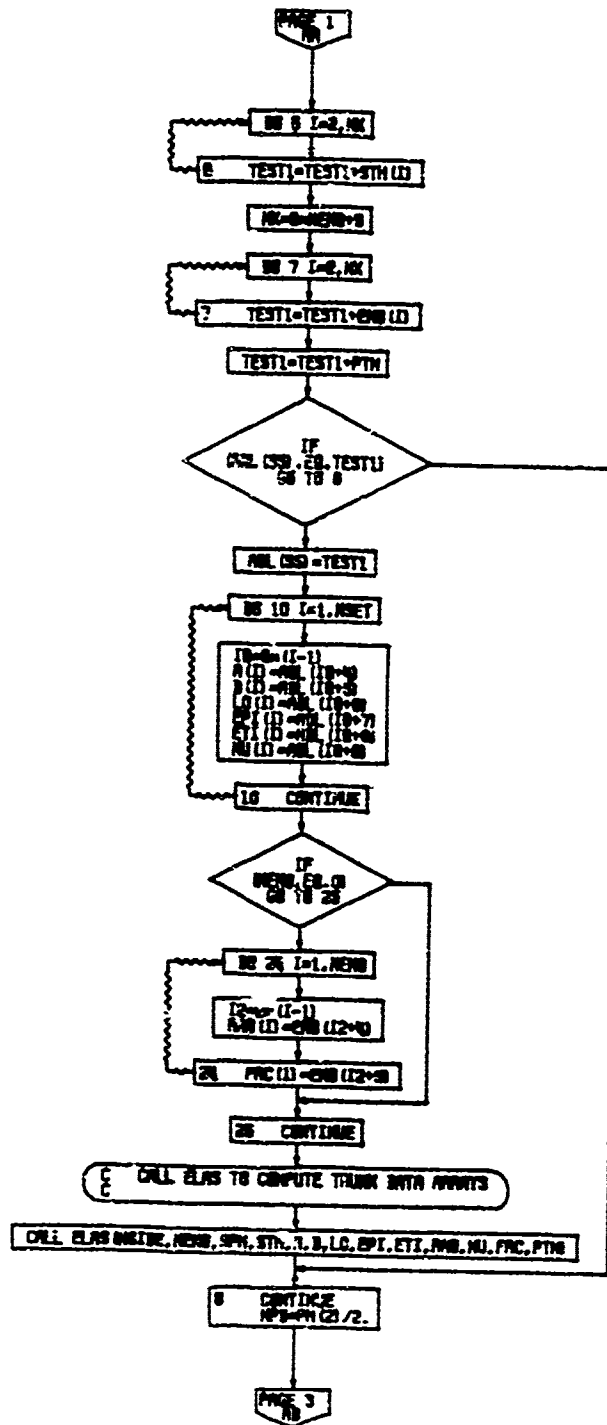

Table 115: FLOWCHART FOR SUBROUTINE TS



PAGE 1
 TS

Table 115: FLOWCHART FOR SUBROUTINE TS (CONTINUED)



PAGE 2
TS

Table 115: FLOWCHART FOR SUBROUTINE TS (CONTINUED)

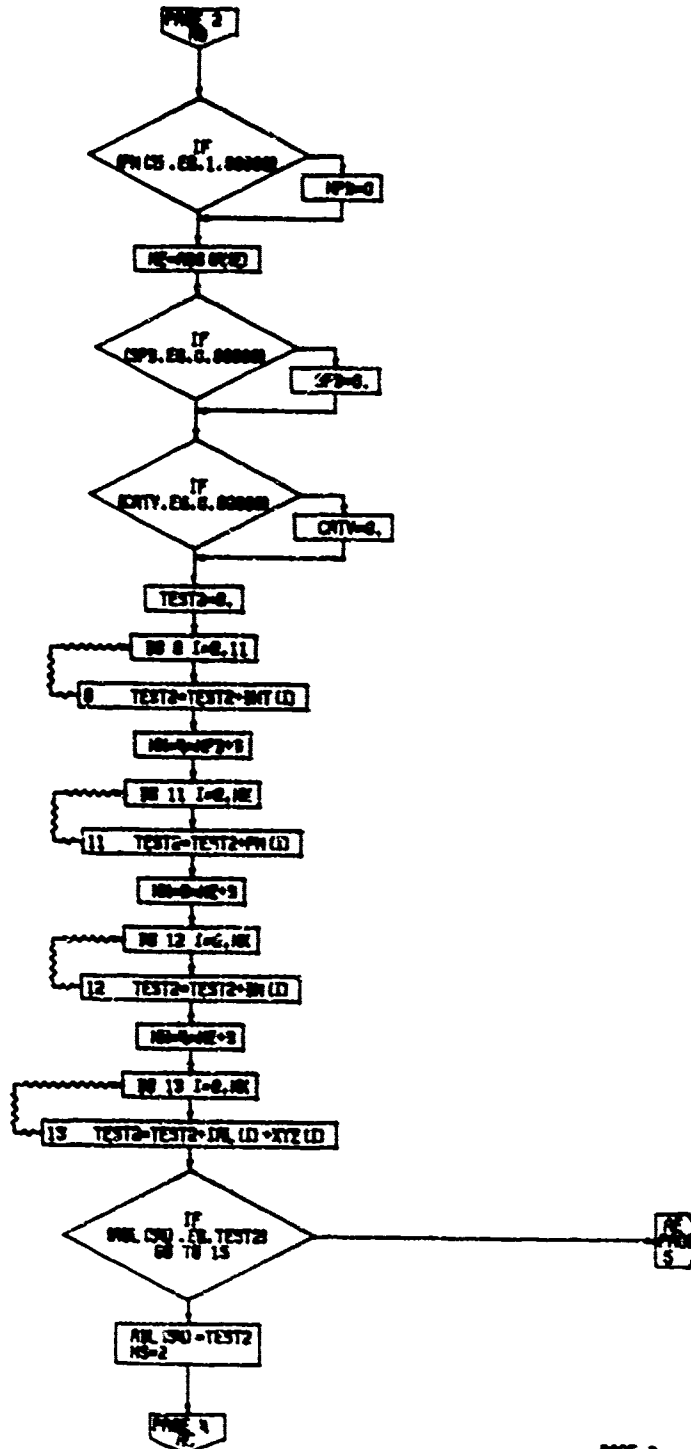

PAGE 3
TS

Table 115: FLOWCHART FOR SUBROUTINE TS (CONTINUED)

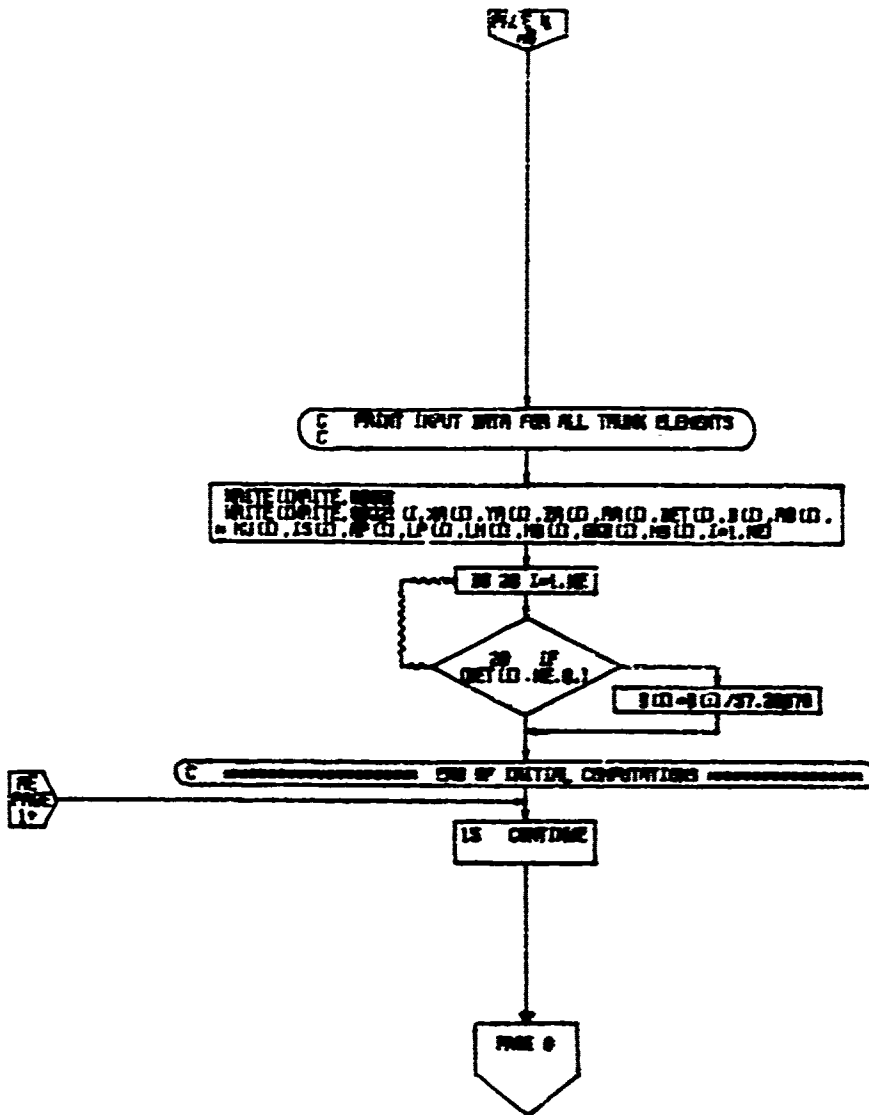

Table 115: FLOWCHART FOR SUBROUTINE TS (CONTINUED)

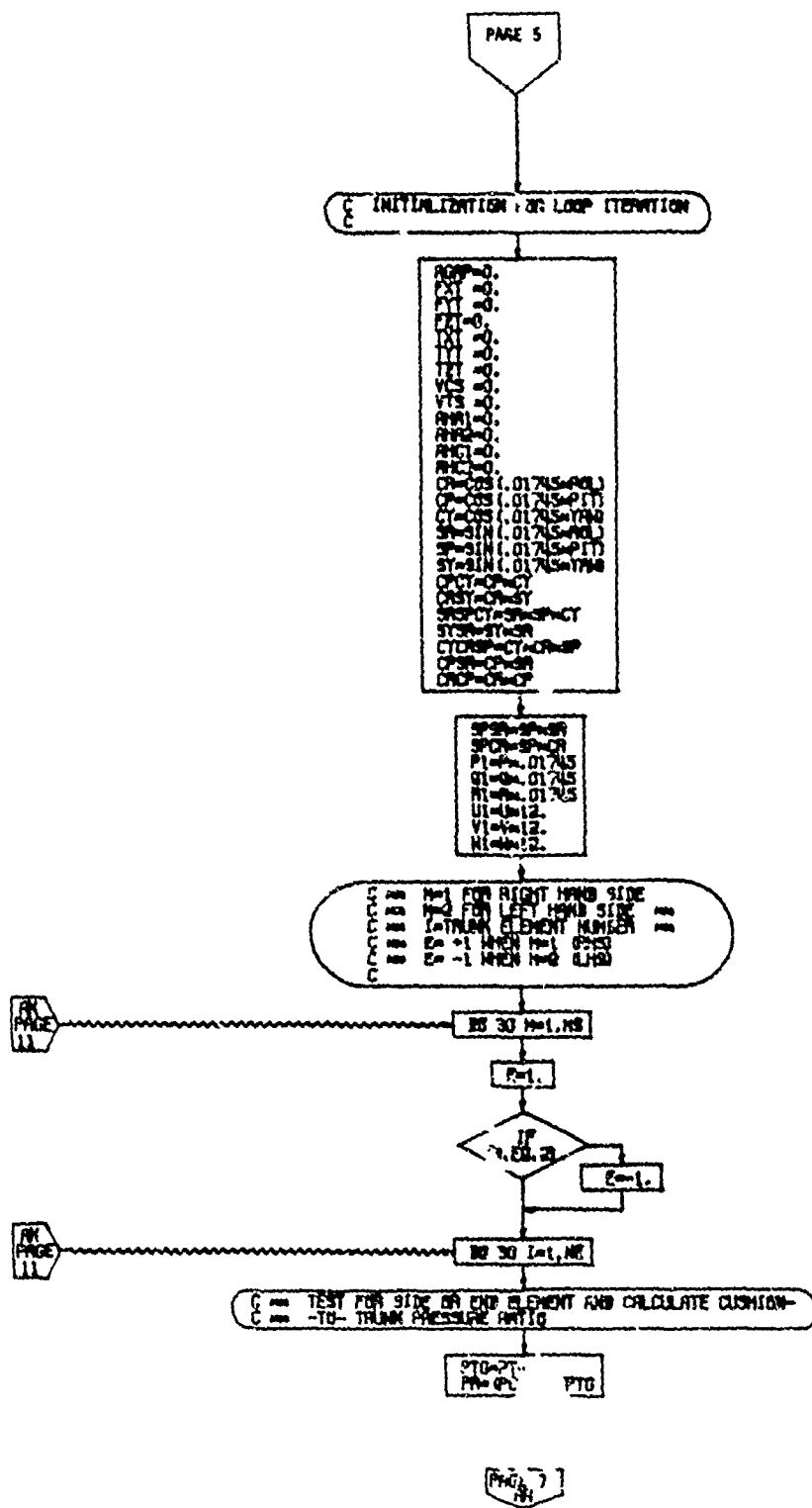
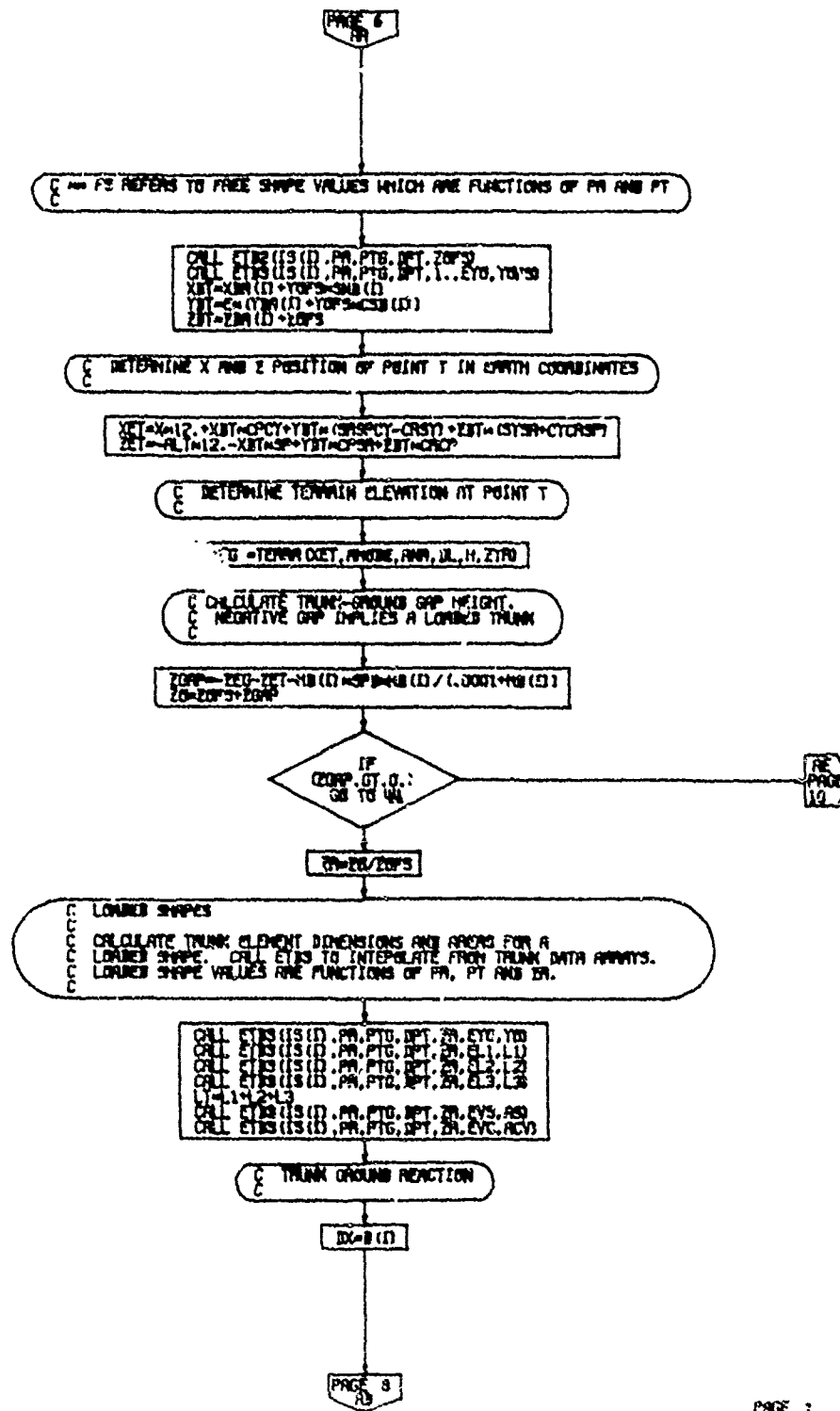

Table 115: FLOWCHART FOR SUBROUTINE TS (CONTINUED)



PAGE 7
TS

Table 115: FLOWCHART FOR SUBROUTINE TS (CONTINUED)

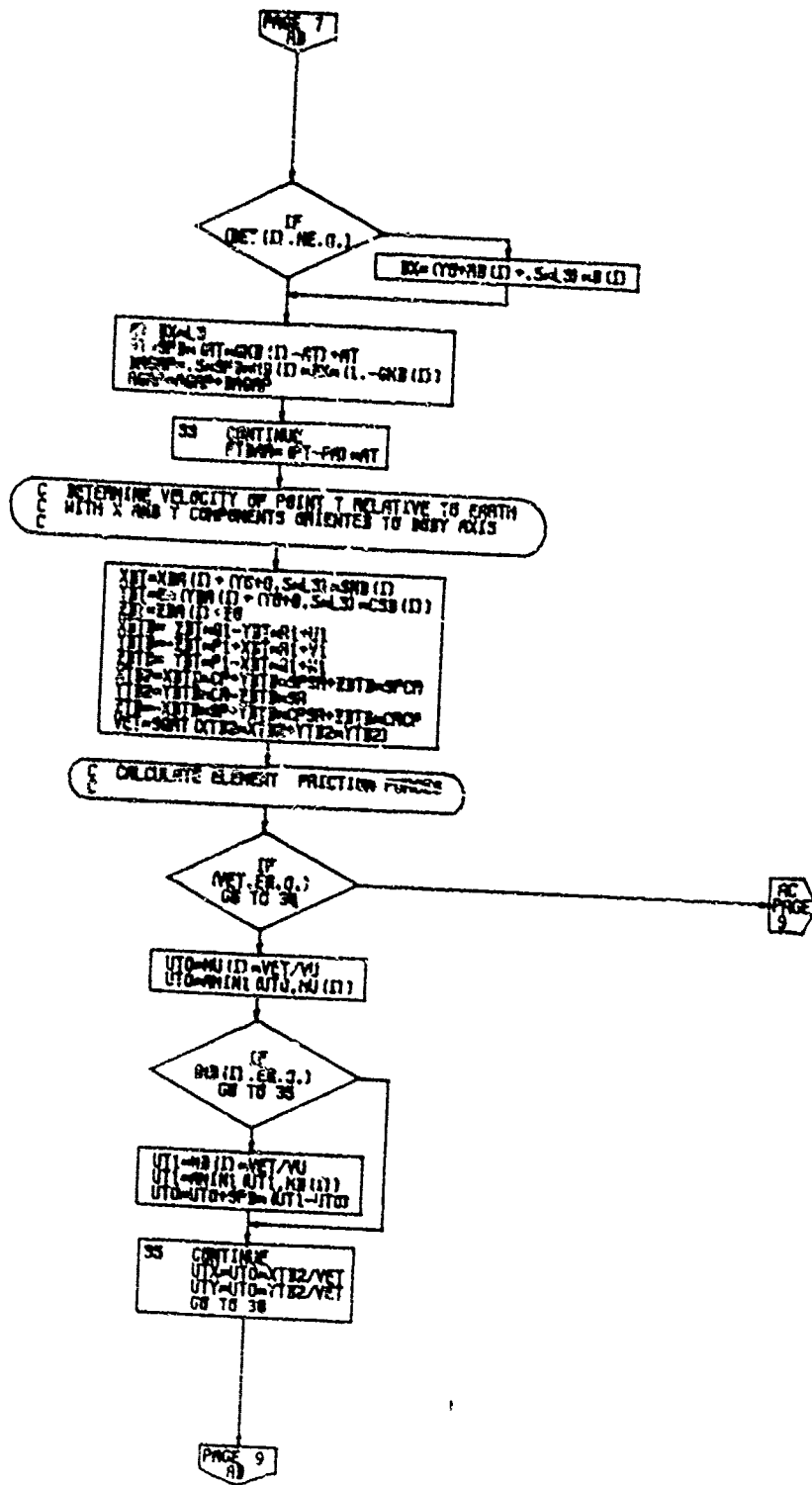

Table 115: FLOWCHART FOR SUBROUTINE TS (CONTINUED)

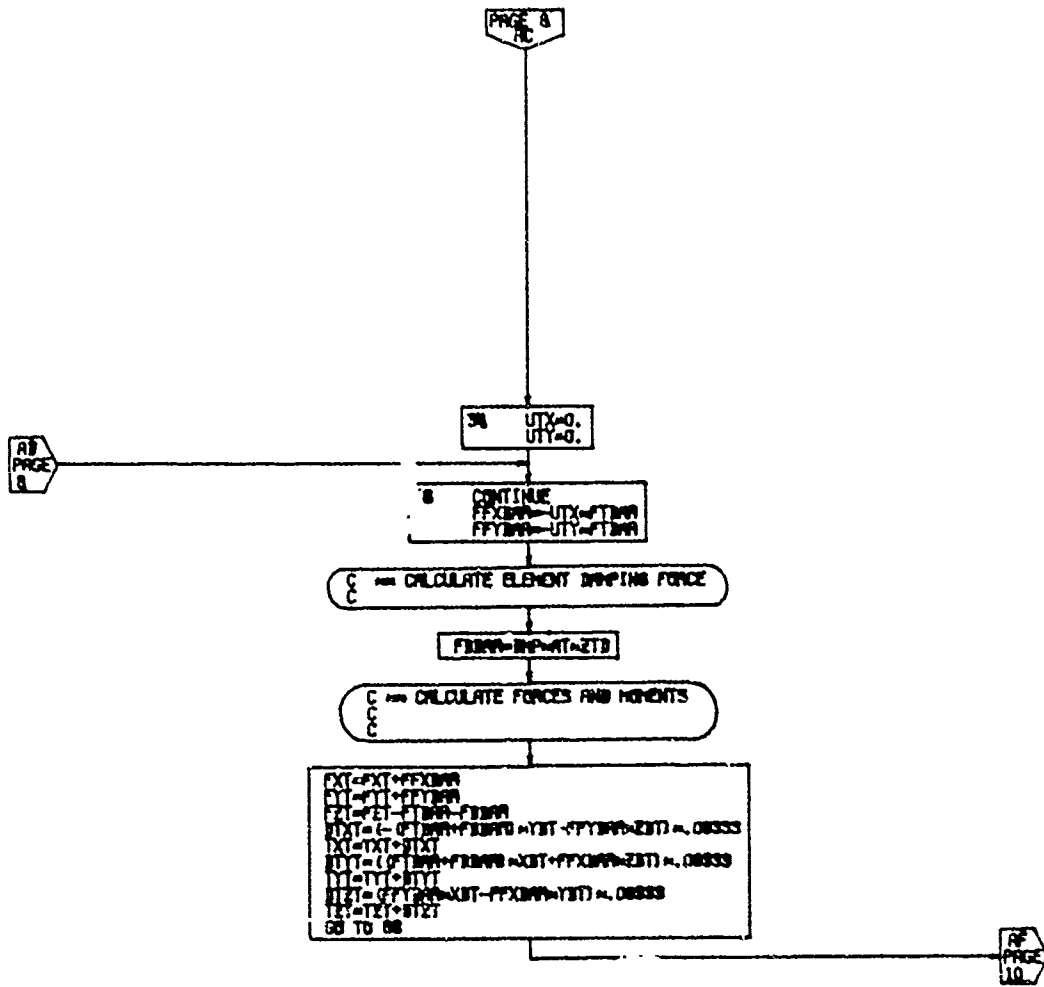
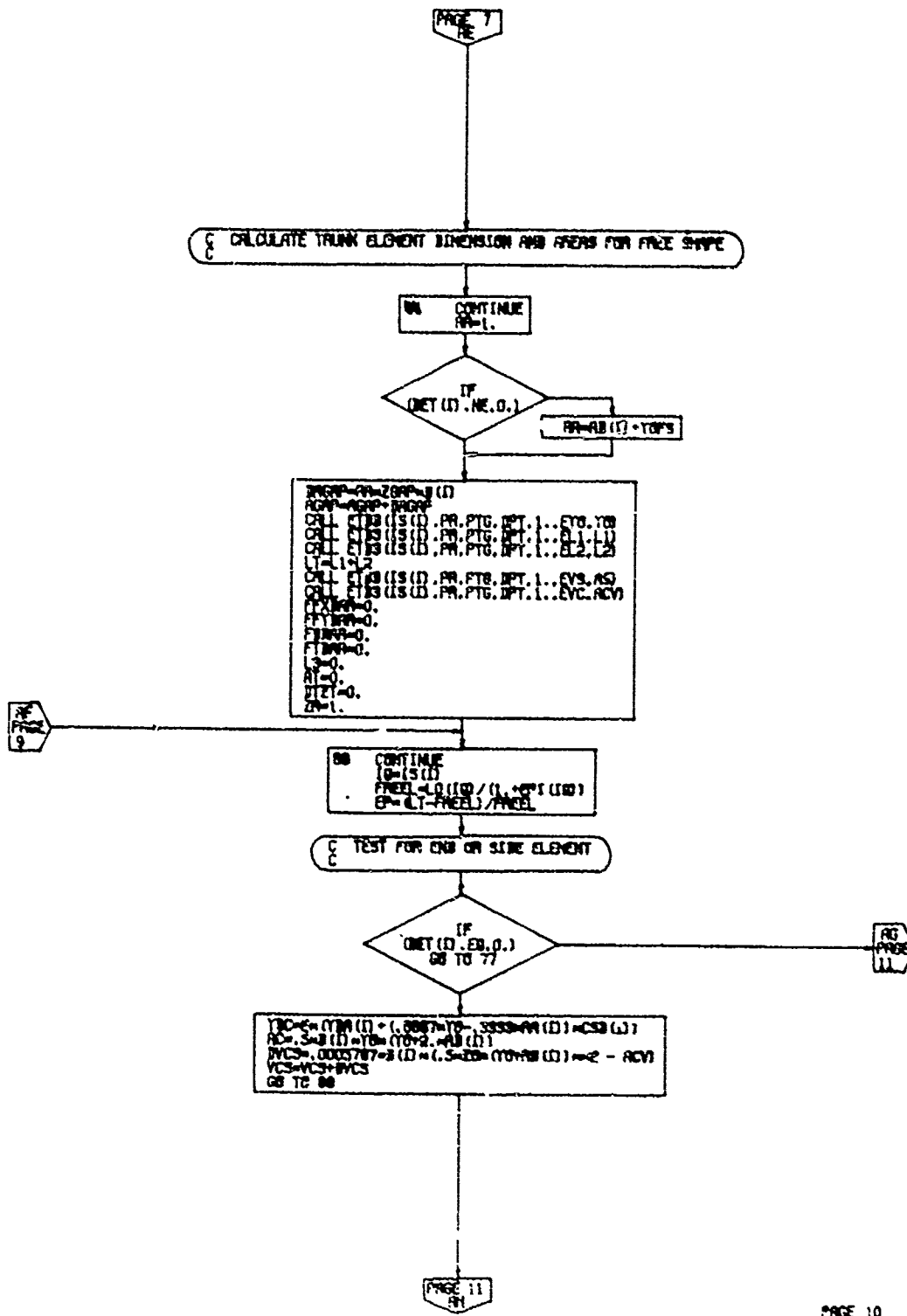

Table 115: FLOWCHART FOR SUBROUTINE TS (CONTINUED)



PAGE 10
TS

Table 115: FLOWCHART FOR SUBROUTINE TS (CONTINUED)

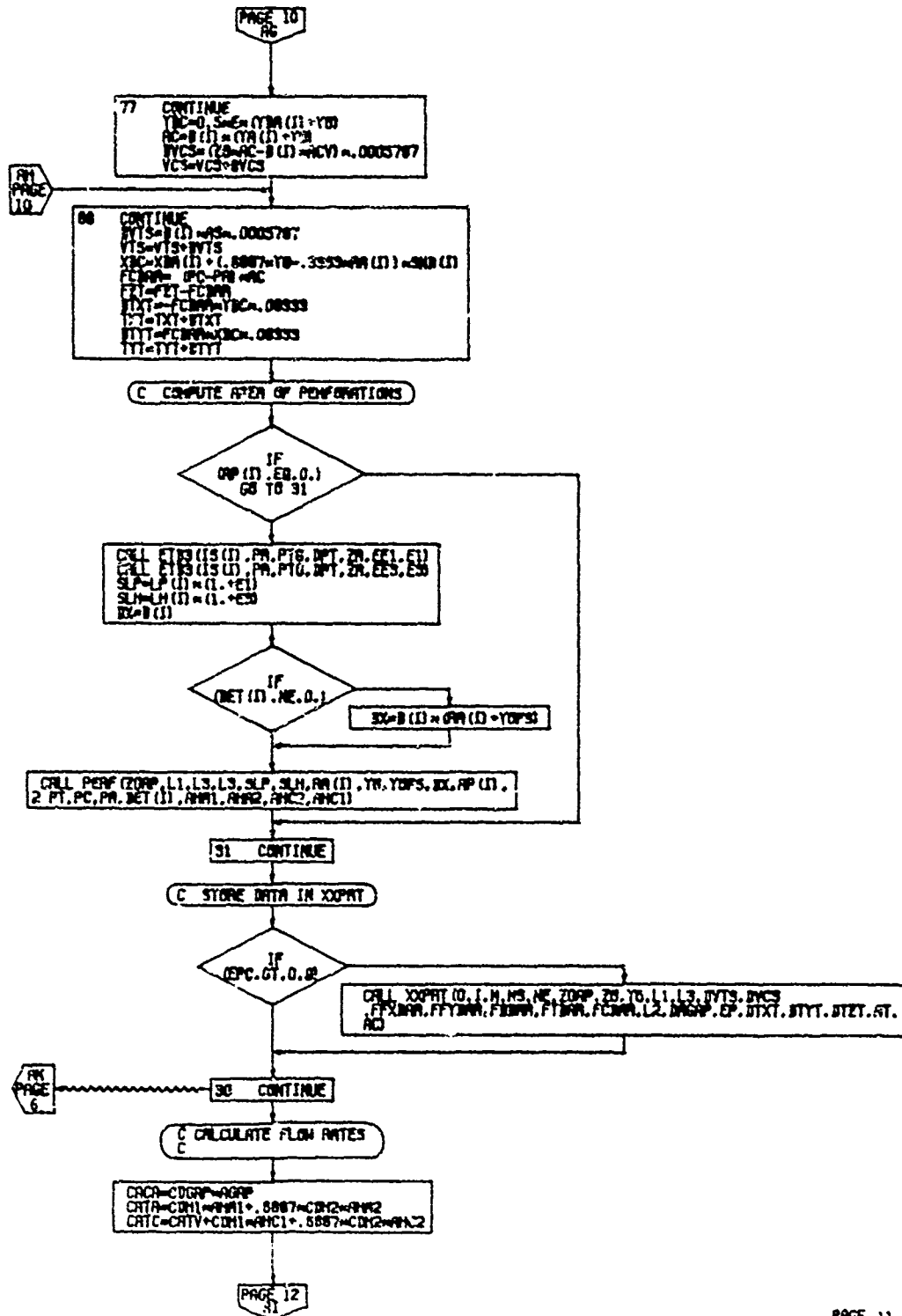
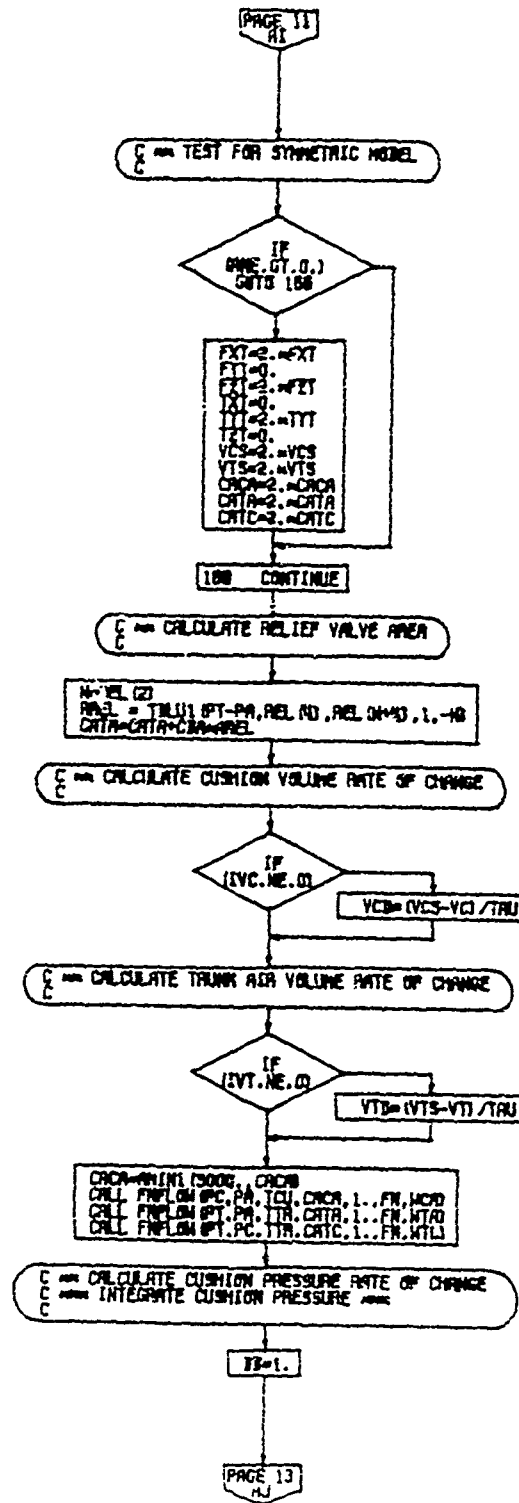

Table 115: FLOWCHART FOR SUBROUTINE TS (CONTINUED)



PAGE 12
TS

Table 115: FLOWCHART FOR SUBROUTINE TS (CONCLUDED)

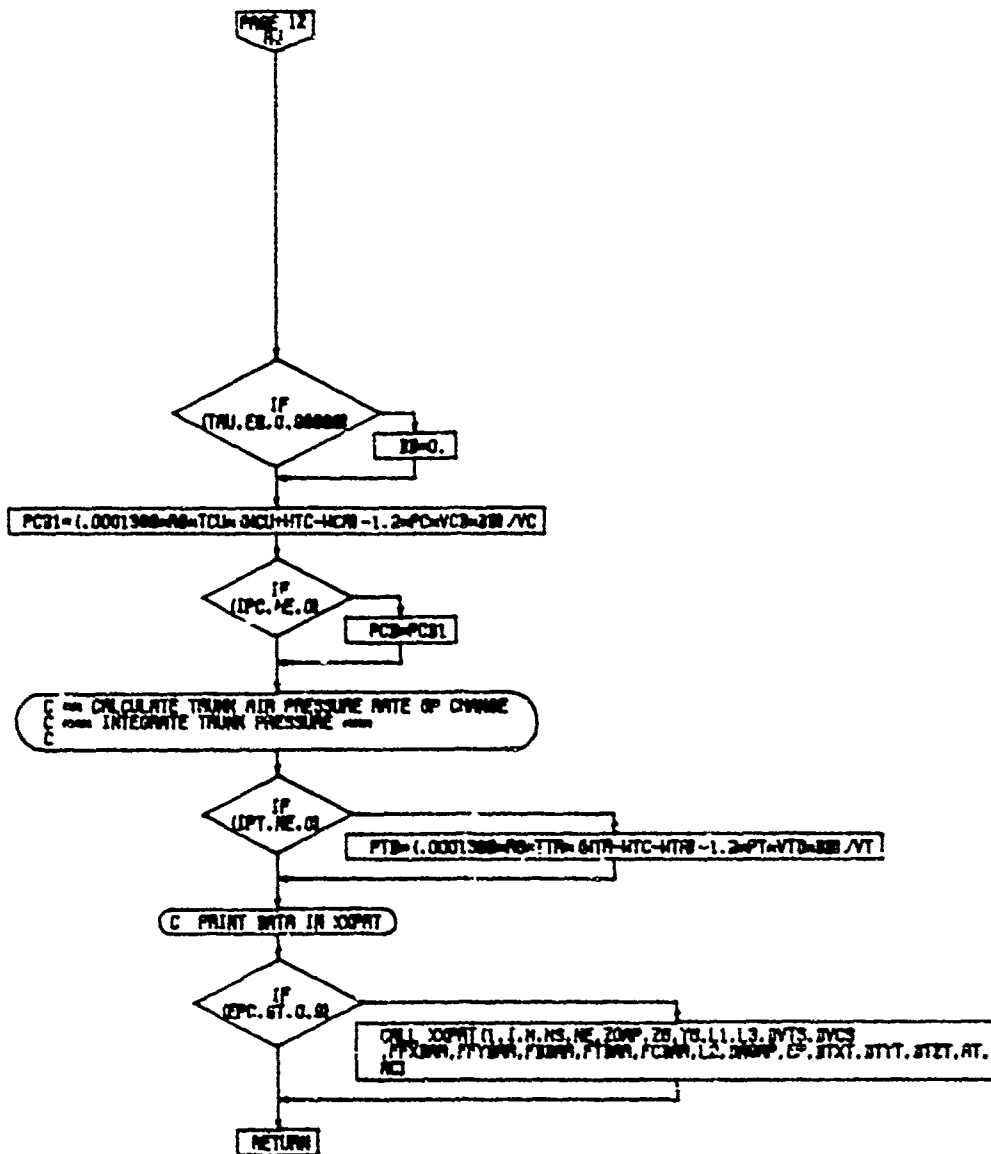
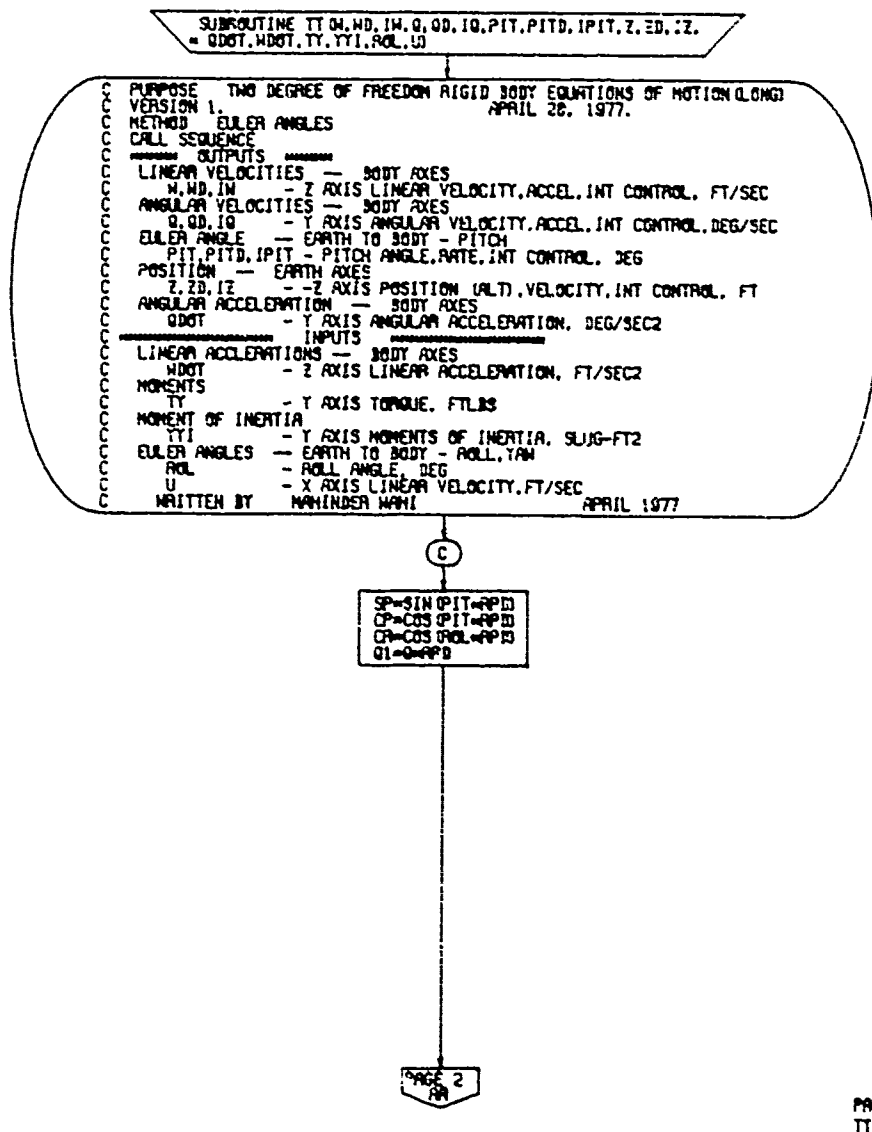

Table 116: FLOWCHART FOR SUBROUTINE TT



PAGE 1
TT

Table 116: FLOWCHART FOR SUBROUTINE TT (CONCLUDED)

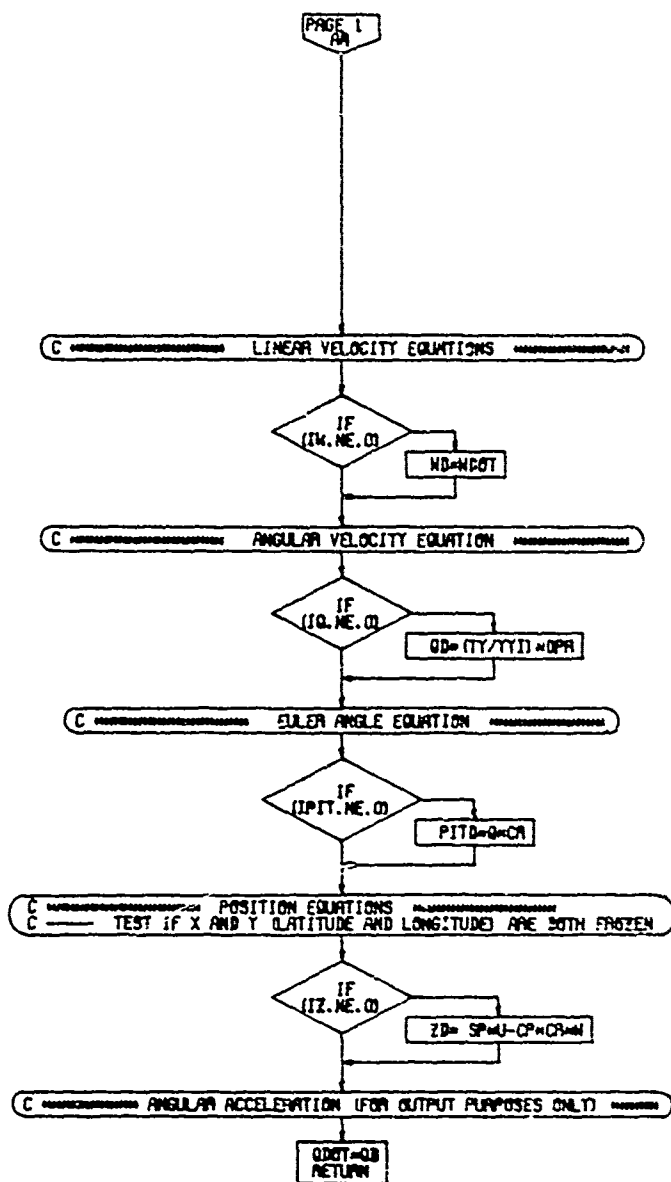

Table 117: FLOWCHART FOR SUBROUTINE TZ

SUBROUTINE TZ (X1, X1DOT, IX1, X2, X2DOT, IX2, FO, FIN, Z0, Z1, Z2, P0, P1)

PURPOSE - TO SIMULATE SECOND ORDER TRANSFER FUNCTION WITH SECOND ORD
NUMERATOR

$$\frac{FO}{FIN} = \frac{Z2 \cdot S + Z1 \cdot S + Z0}{S^2 + P1 \cdot S + P0}$$

METHOD - SELF EXPLANATORY

LIMITATIONS - NONE

WRITTEN BY - ADAM LLOYD LATEST REVISION NOV 75

INPUT/OUTPUT LIST

X1	FIRST STATE VARIABLE	ANY	OUTPUT STATE
X1DOT	FIRST STATE VARIABLE DERIVATIVE	ANY	OUTPUT STATE
IX1	INTEGRATOR CONTROL		PROGRAM VAR
X2	SECOND STATE VARIABLE	ANY	OUTPUT STATE
X2DOT	SECOND STATE VARIABLE DERIVATIVE	ANY	OUTPUT STATE
IX2	INTEGRATOR CONTROL		PROGRAM VAR
FO	TRANSFER FUNCTION OUTPUT	ANY	OUTPUT VAR

FIN	TRANSFER FUNCTION INPUT		INPUT VAR
Z0	NUMERATOR COEFFICIENT		INPUT PARAM
Z1	NUMERATOR COEFFICIENT		INPUT PARAM
Z2	NUMERATOR COEFFICIENT	ANY	INPUT PARAM
P0	DENOMINATOR COEFFICIENT	1/SEC2	INPUT PARAM
P1	DENOMINATOR	1/SEC	INPUT PARAM

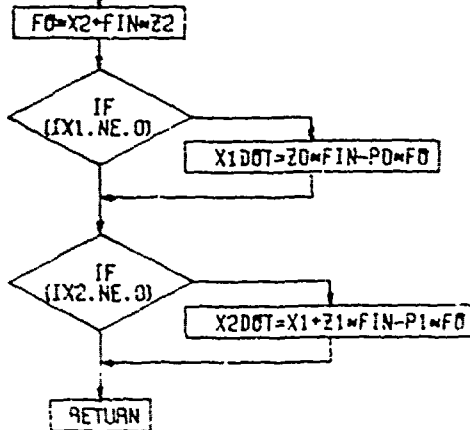

Table 118: FLOWCHART FOR SUBROUTINE VA

SUBROUTINE VA QD, YD, HD, PD, QD, RD, DIMD, QND, RND, CRD, SRD, AL, RLP,
 1 YBAR, BETA, MP, LP, EU, EV, EM, SIGZ, QCON, QBAR, XNACH, U, V, W,
 2 P, Q, R, Z, P1, ROL, DIM, VS, ALS, S, LM, YH, NH, PH, QH, RH, DIGI

VERSION 1. MAY 16 1977
 PURPOSE: COMPUTE AERO VARIABLES FROM STATES
 CALL SEQUENCE:
 OUTPUTS
 OUTPUT VARIABLES- INPUTS --
 QD, YD, HD -X, Y, Z BODY AXIS LINEAR VELOCITY WITH WIND, FT/SEC
 PD, QD, RD -X, Y, Z BODY AXIS ANGULAR RATES WITH WIND, DEG/SEC
 DIMD -INDICATOR FOR AERO FORCES AND MOMENTS = DIM
 QND, RND -Q AND R ANGULAR RATE GUSTS, DEG/SEC
 AERO VARIABLES --
 CRD, SRD -DIRECTION COSINES FOR STABILITY AXIS TRANSFORM
 AL, RLP -ANGLE OF ATTACK IN BODY AND STABILITY AXES, DEG
 YBAR -TRUE AIRSPEED, FT/SEC
 BETA -SIDE SLIP ANGLE, DEG
 MP, LP -Y AND X STABILITY AXIS VELOCITIES, FT/SEC (DIMENSIONAL)
 EU, EV, EM -Z AND X PERTURBATION VELOCITIES (NONDIMENSIONAL)
 -X, Y, Z BODY AXIS ACCELERATION TERMS FOR UDOT, VDOT,
 WDOT SOLUTIONS, FT/SEC²
 STANDARD ATMOSPHERE VARIABLES --
 SIGZ -AIR DENSITY RATIO
 QCON -COMPRESSIBLE DYNAMIC PRESSURE, LBS/FT²
 QBAR -DYNAMIC PRESSURE TIMES REFERENCE AREA, LBS
 XNACH -MACH NUMBER
 INPUTS
 STATE VARIABLES
 U, V, W -X, Y, Z BODY AXIS LINEAR VELOCITIES, FT/SEC

P, Q, R -X, Y, Z BODY AXIS ANGULAR RATES, DEG/SEC
 Z -ALTITUDE ABOVE SEA-LEVEL, FT
 PIT, ROL -PITCH AND ROLL, EARTH TO BODY AXIS EULER ANGLES, DE
 INDICATOR FUNCTION FOR AERO FORCES AND MOMENTS
 DIM = 0 -BODY AXIS, DIMENSIONAL
 1 -BODY AXIS, NONDIMENSIONAL
 2 -STABILITY AXIS, DIMENSIONAL
 3 -STABILITY AXIS, NONDIMENSIONAL
 CONSTANTS --
 VS -STEADY STATE AIRSPEED, FT/SEC
 ALS -STEADY STATE ANGLE OF ATTACK, DEG
 S -REFERENCE AREA, FT²
 WIND STATES --
 LH, YH, NH -X, Y, Z BODY AXIS WIND VELOCITIES, FT/SEC
 PH, QH, RH -X, Y, Z BODY AXIS WIND ANGULAR RATES, DEG/SEC
 INDICATOR FUNCTION FOR DEGREES OF FREEDOM (DOF)
 DIG = 2 -TWO DOF LONGITUDINAL (S, Q)
 3 -THREE DOF LONGITUDINAL (U, W, Q)
 4 -FOUR DOF LATERAL (V, P, R) + LONGI. RD
 5 -THREE DOF LATERAL (V, P, R)
 6 -SIX DOF FULL MODEL (U, V, W, P, Q, R)
 WRITTEN BY WALTER WASHI MAY 1977

INITIALIZATION

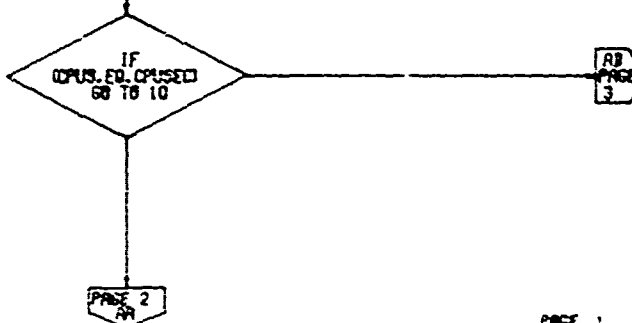

PAGE 1
 VA

Table 118: FLOWCHART FOR SUBROUTINE VA (CONTINUED)

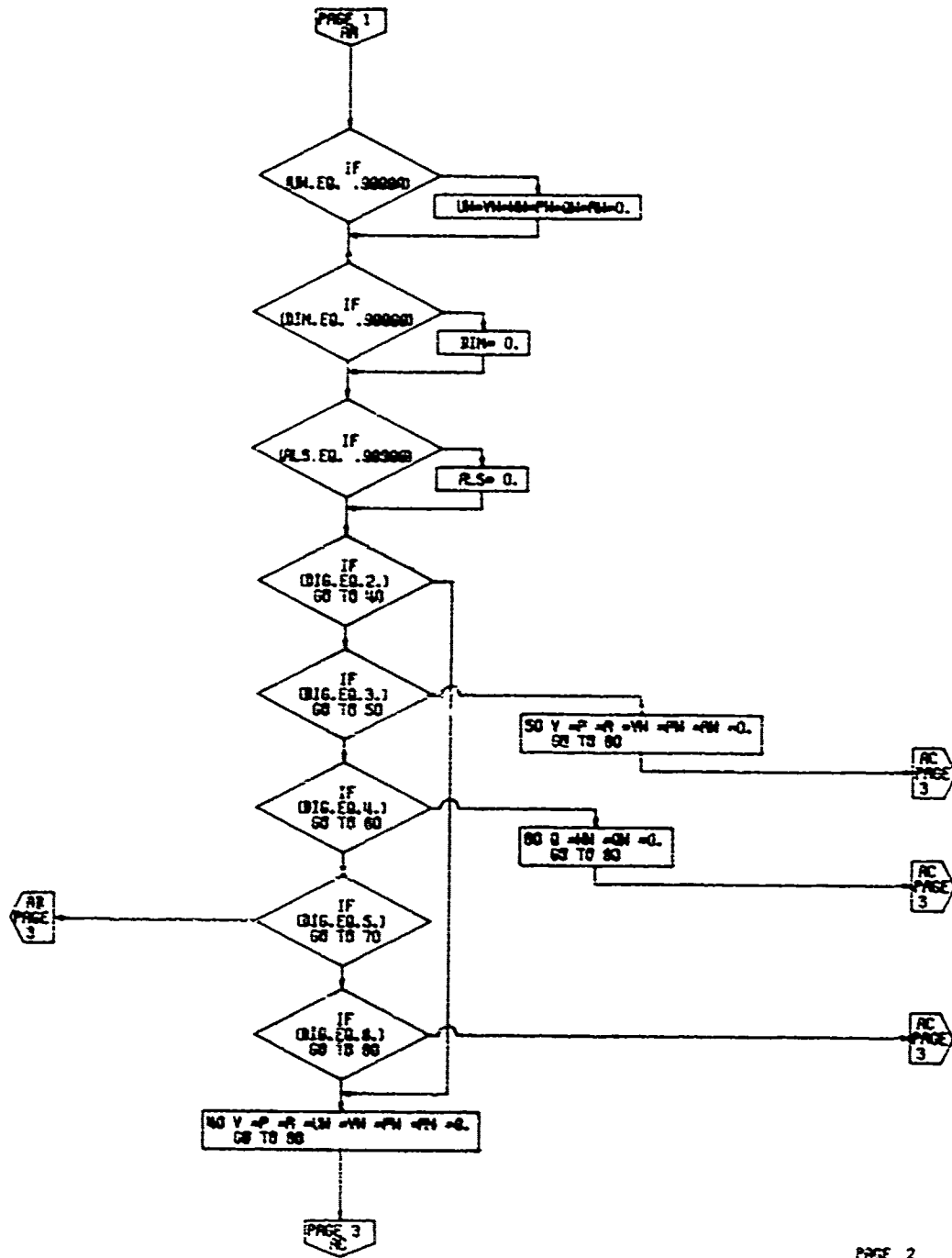

Table 118: FLOWCHART FOR SUBROUTINE VA (CONTINUED)

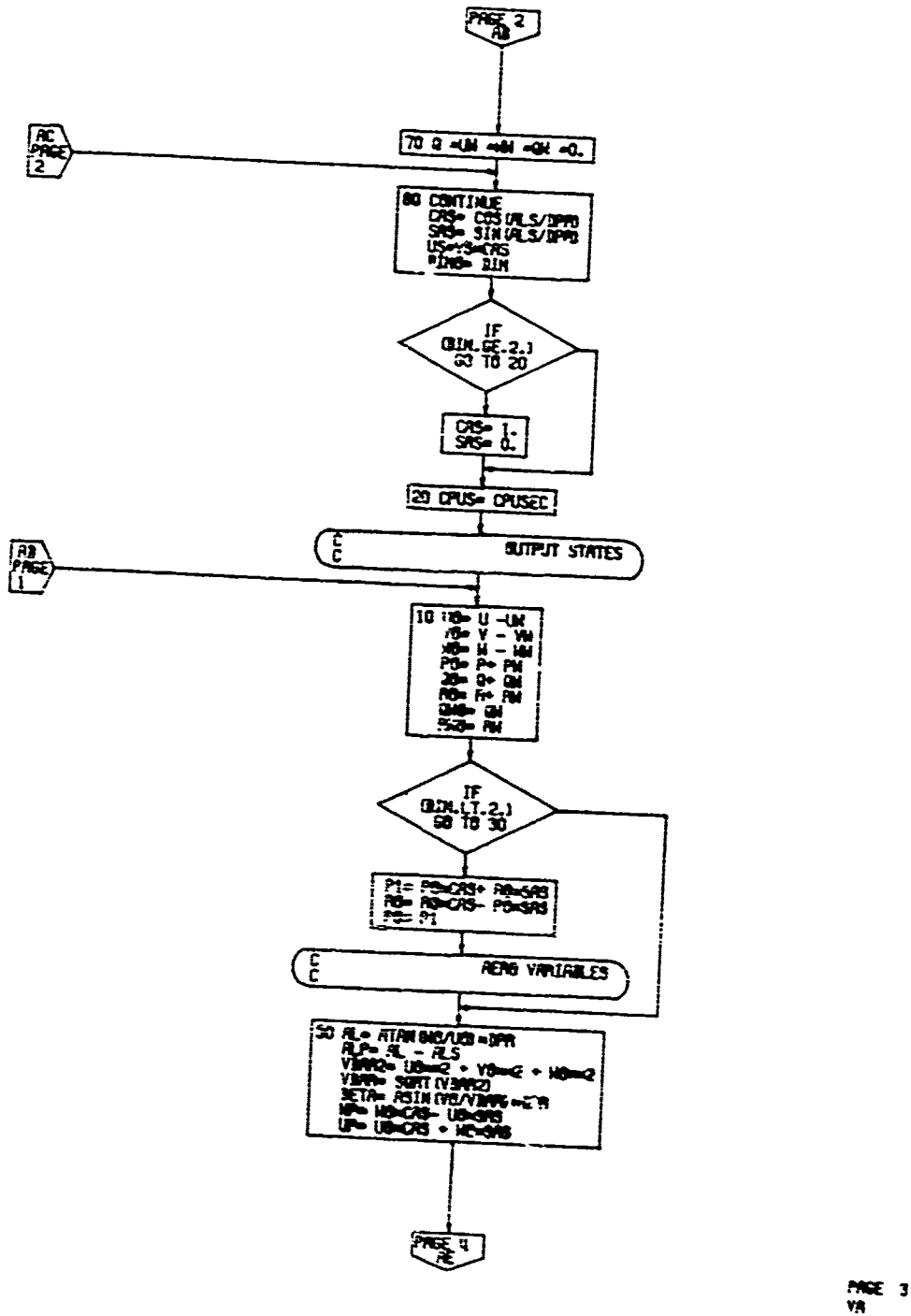

Table 178: FLOWCHART FOR SUBROUTINE VA (CONCLUDED)

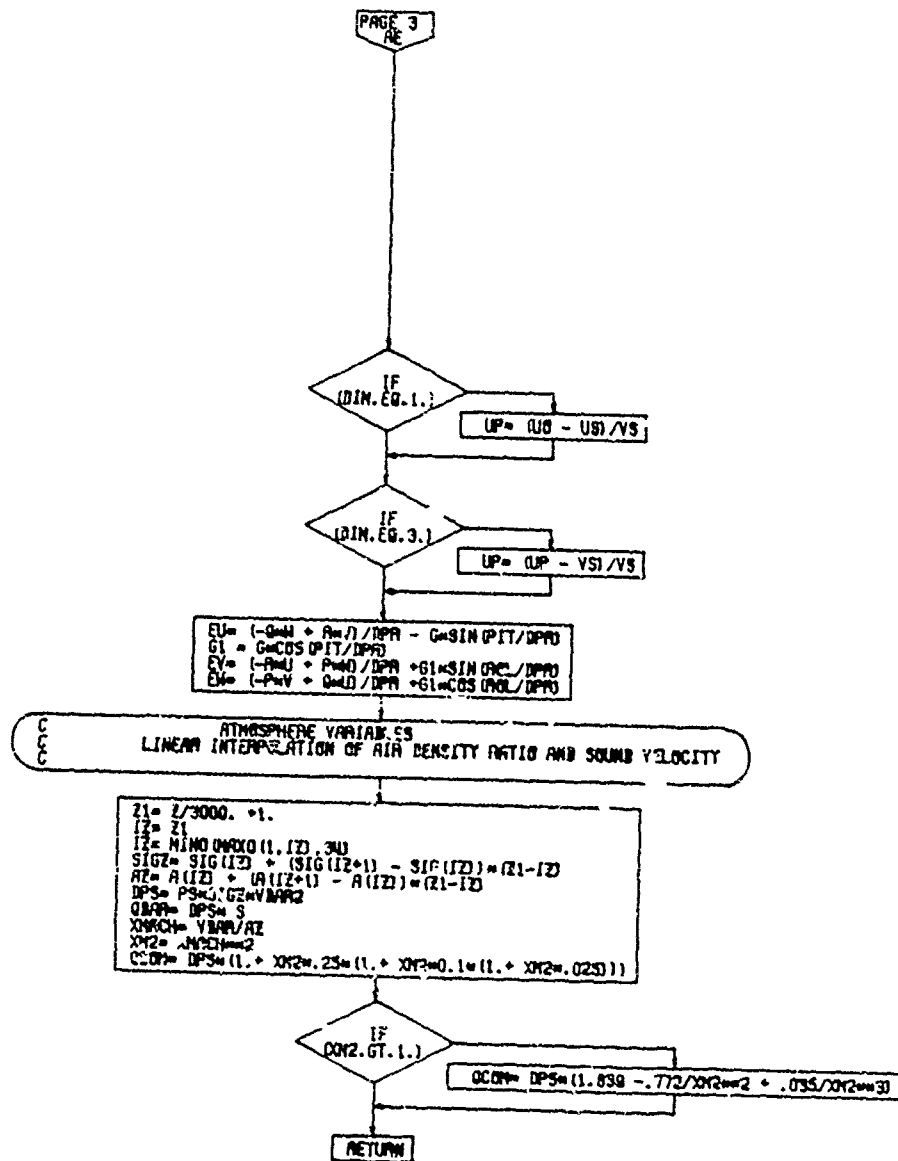
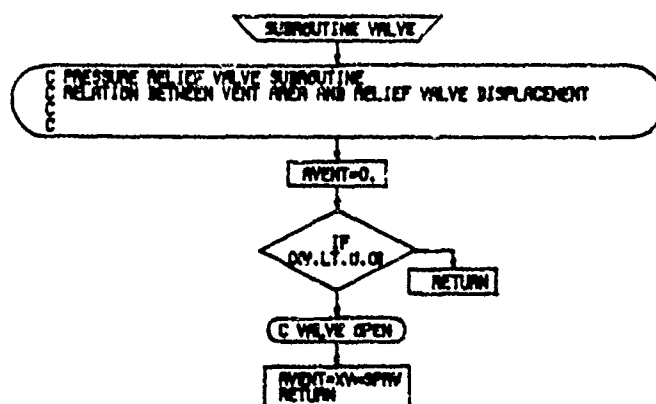

Table 119: FLOWCHART FOR SUBROUTINE VALVE



77
VALVE

Table 120: FLOWCHART FOR SUBROUTINE VLX

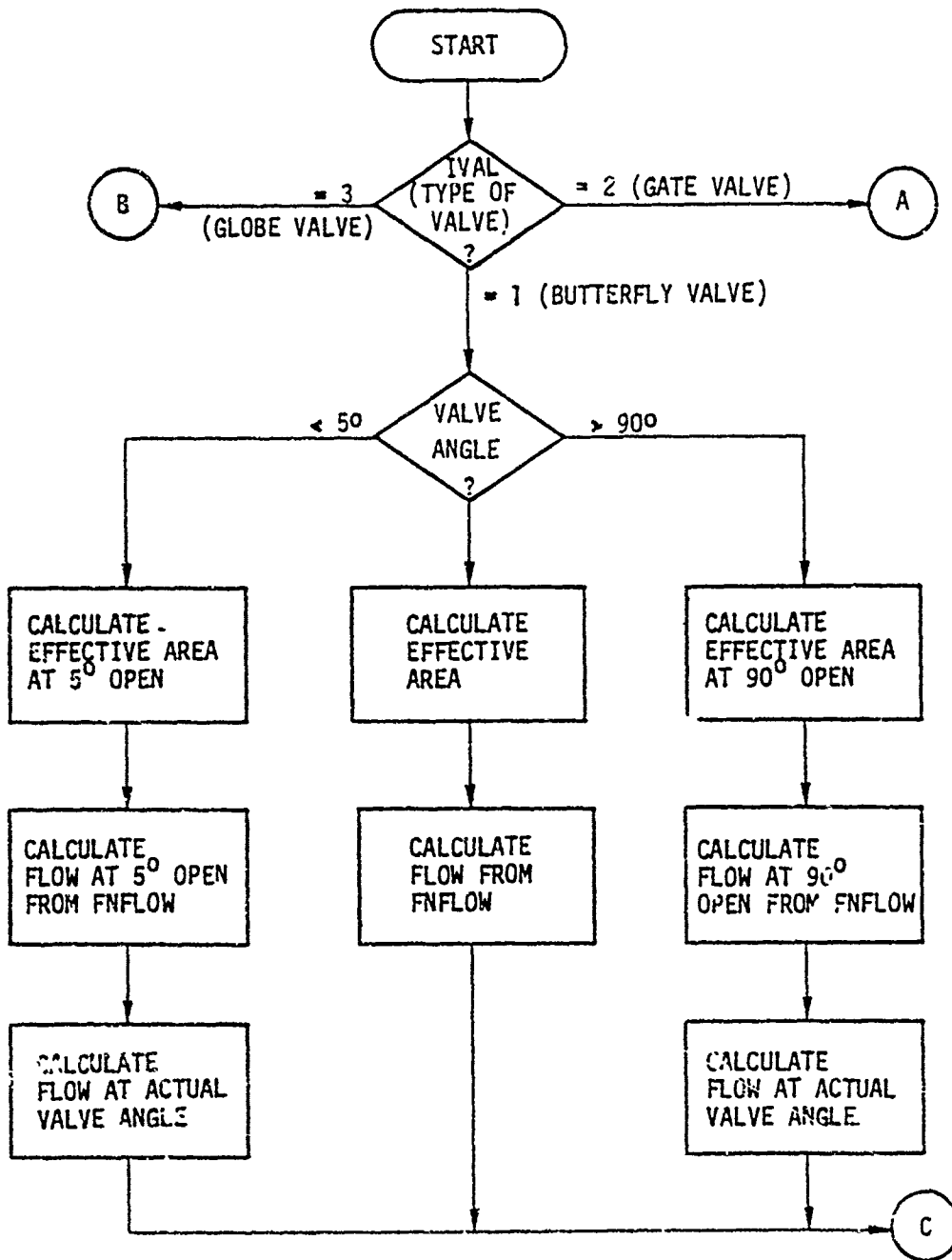

Table 120: FLOWCHART FOR SUBROUTINE VLX (CONCLUDED)

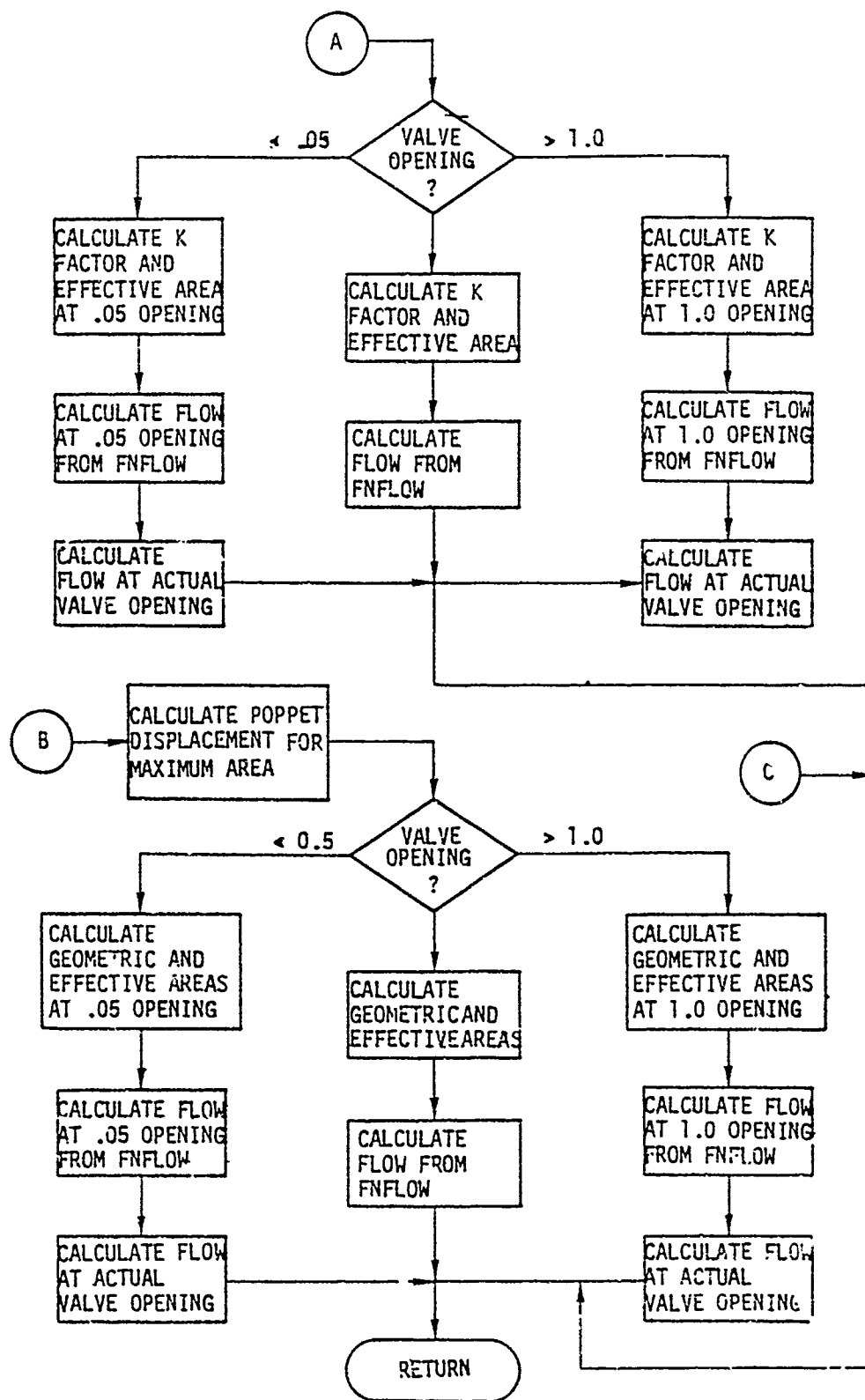

Table 121: FLOWCHART FOR SUBROUTINE VPRINB

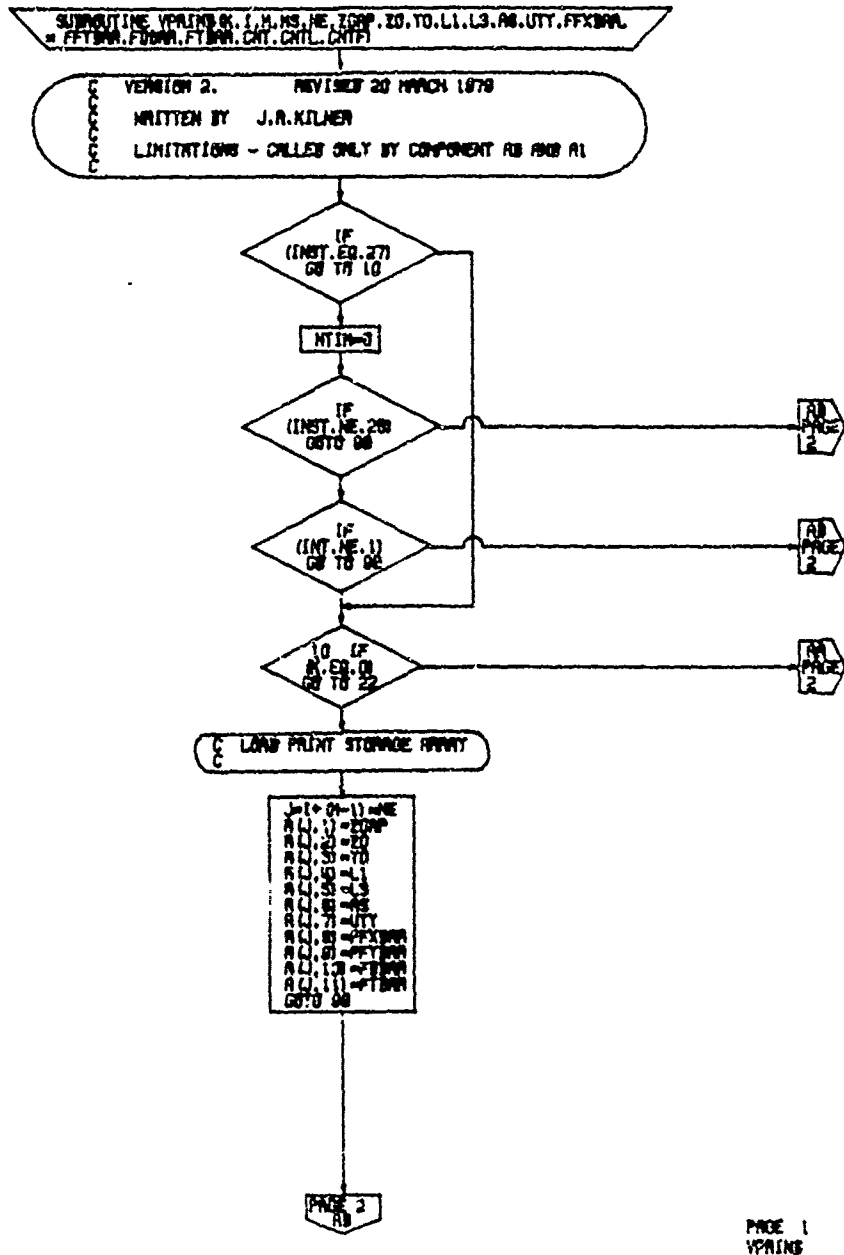

Table 121: FLOWCHART FOR SUBROUTINE VPRINB (CONCLUDED)

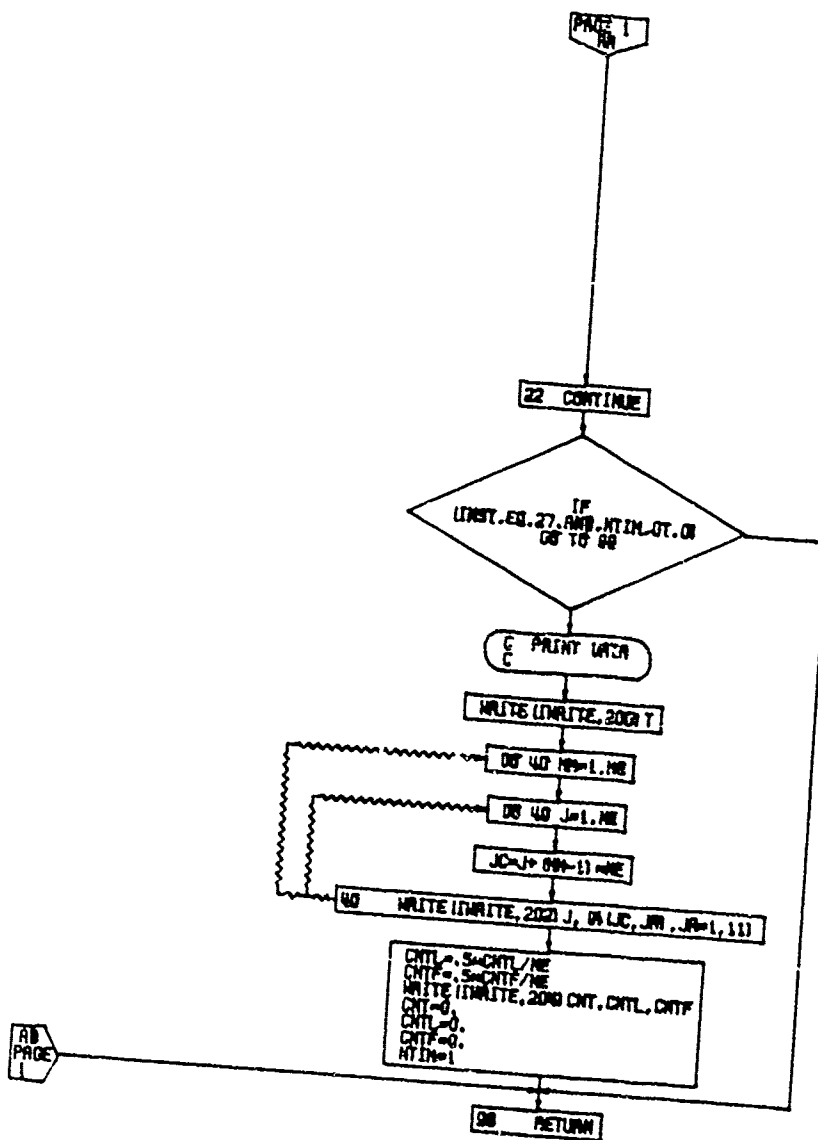
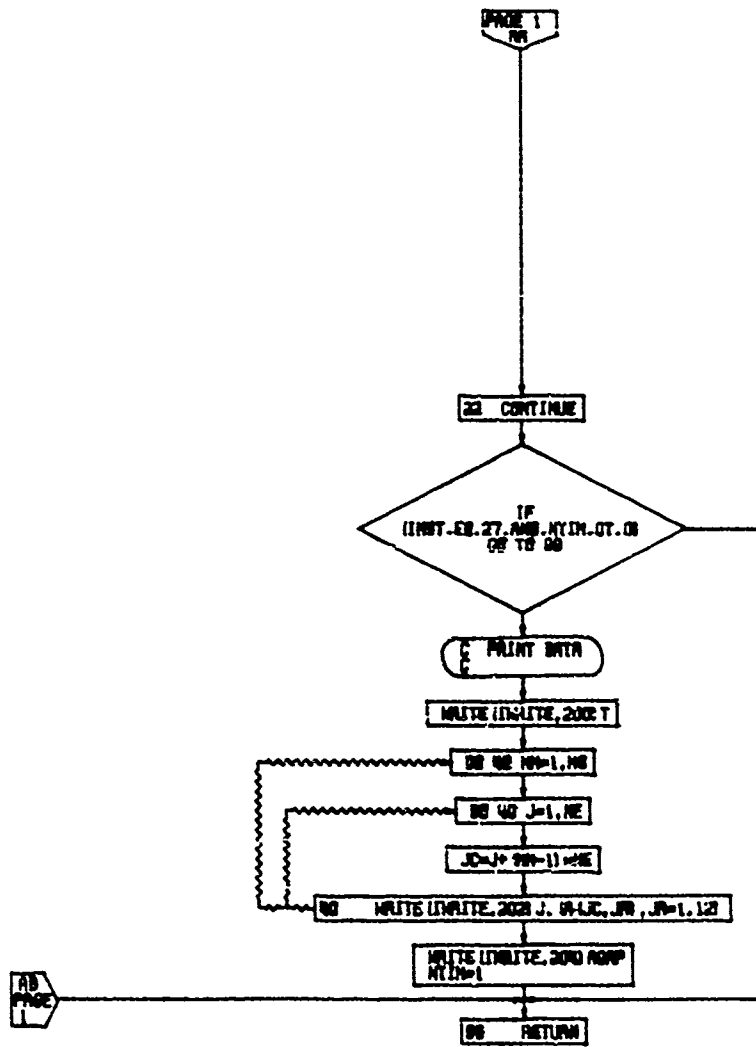

Table 122: FLOWCHART FOR SUBROUTINE VPRINT (CONCLUDED)



PAGE 2
VPRINT

Table 123: FLOWCHART FOR SUBROUTINE WS

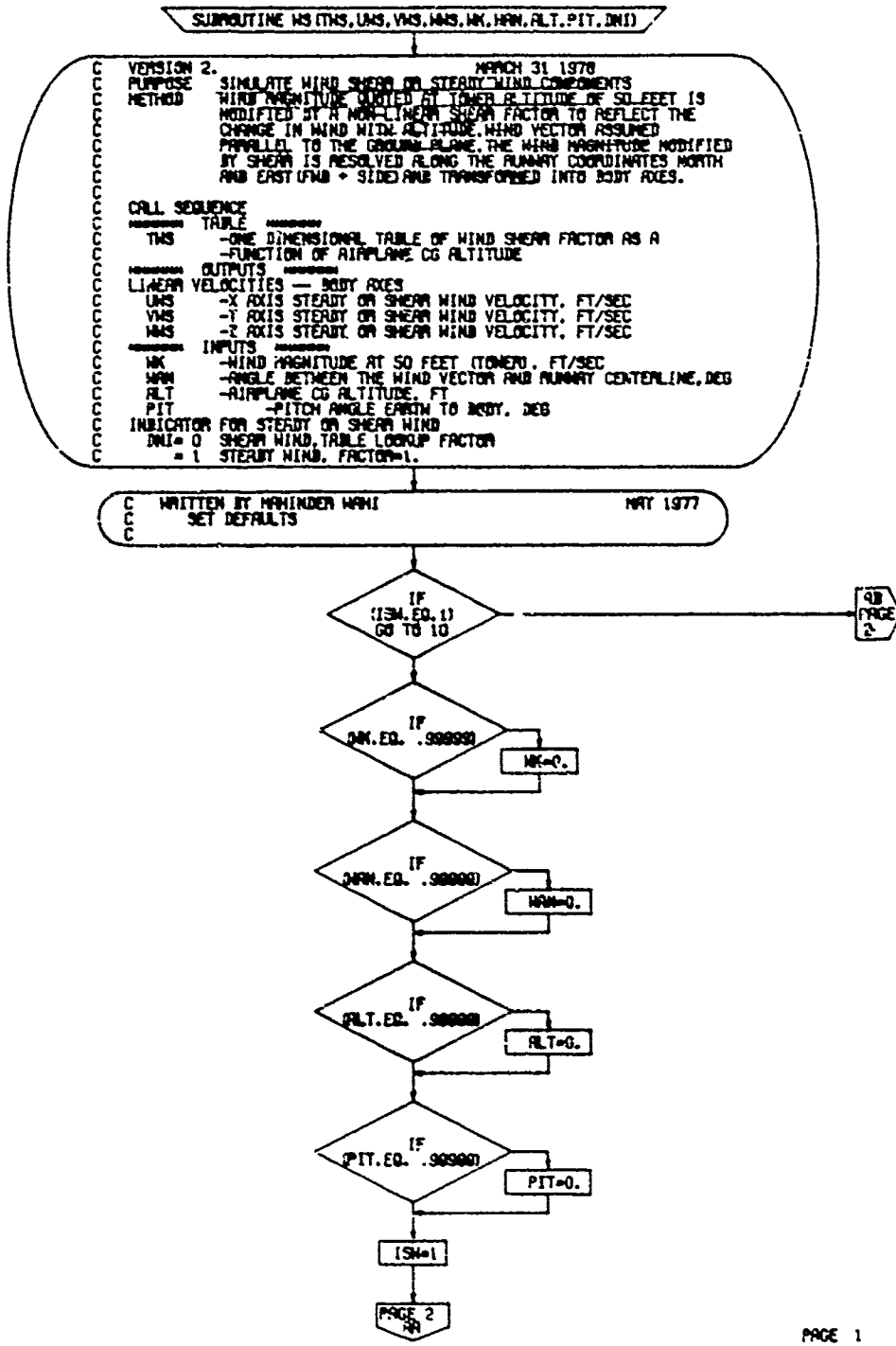
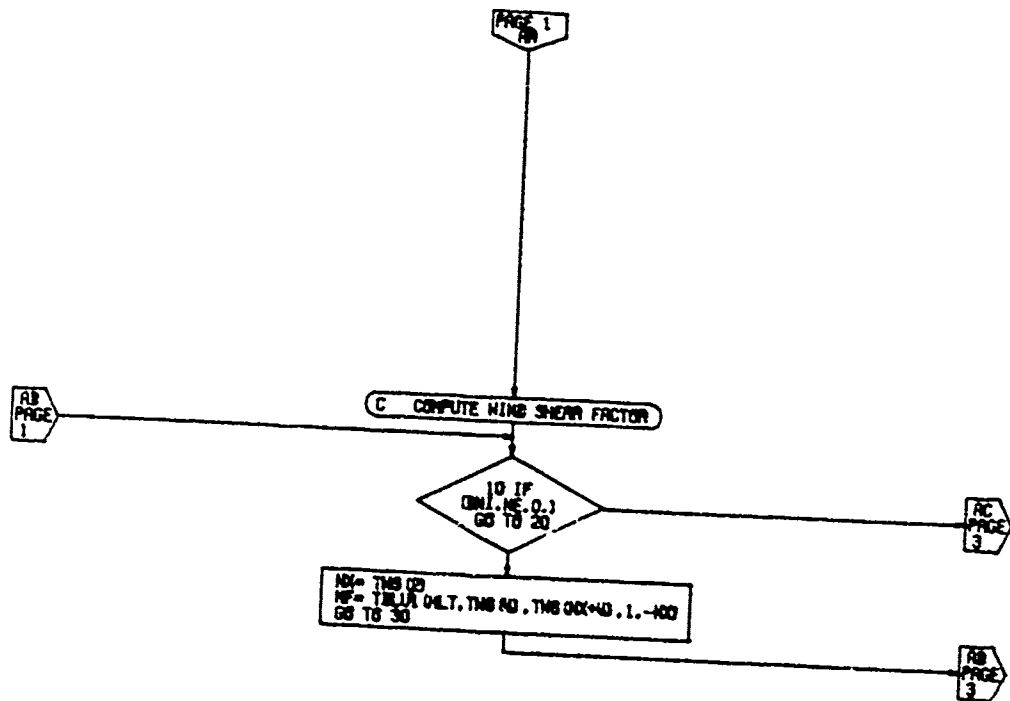

Table 123: FLOWCHART FOR SUBROUTINE WS (CONTINUED)



PAGE 2
MS

Table 123: FLOWCHART FOR SUBROUTINE WS (CONCLUDED)

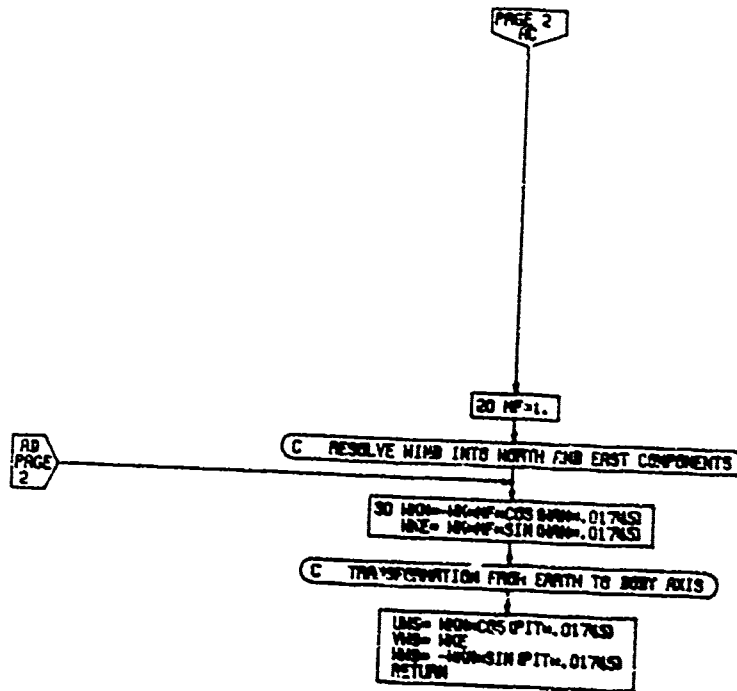

Table 124: FLOW FOR SUBROUTINE XP

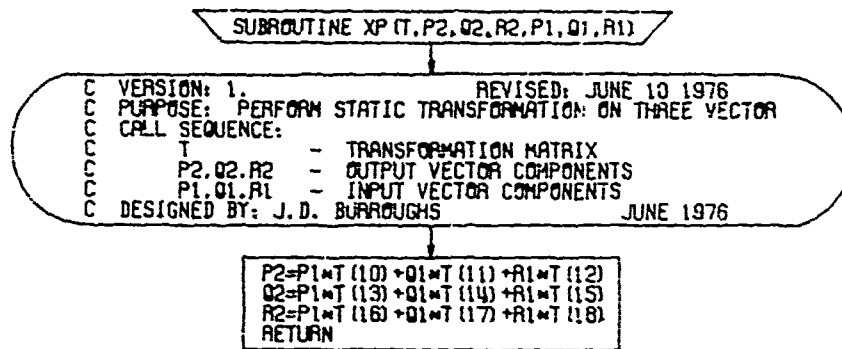

Table 125: FLOWCHART FOR SUBROUTINE XT

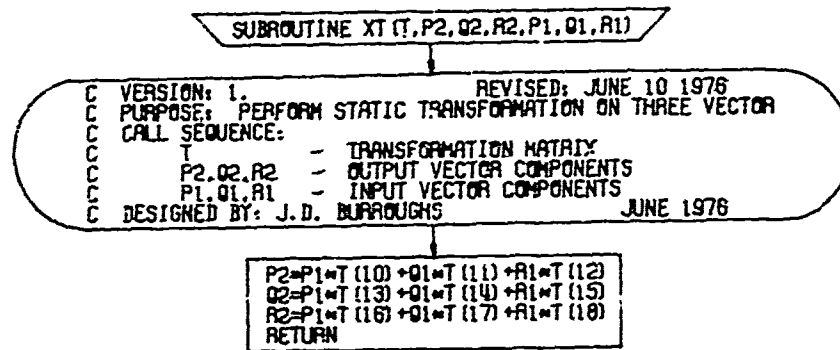
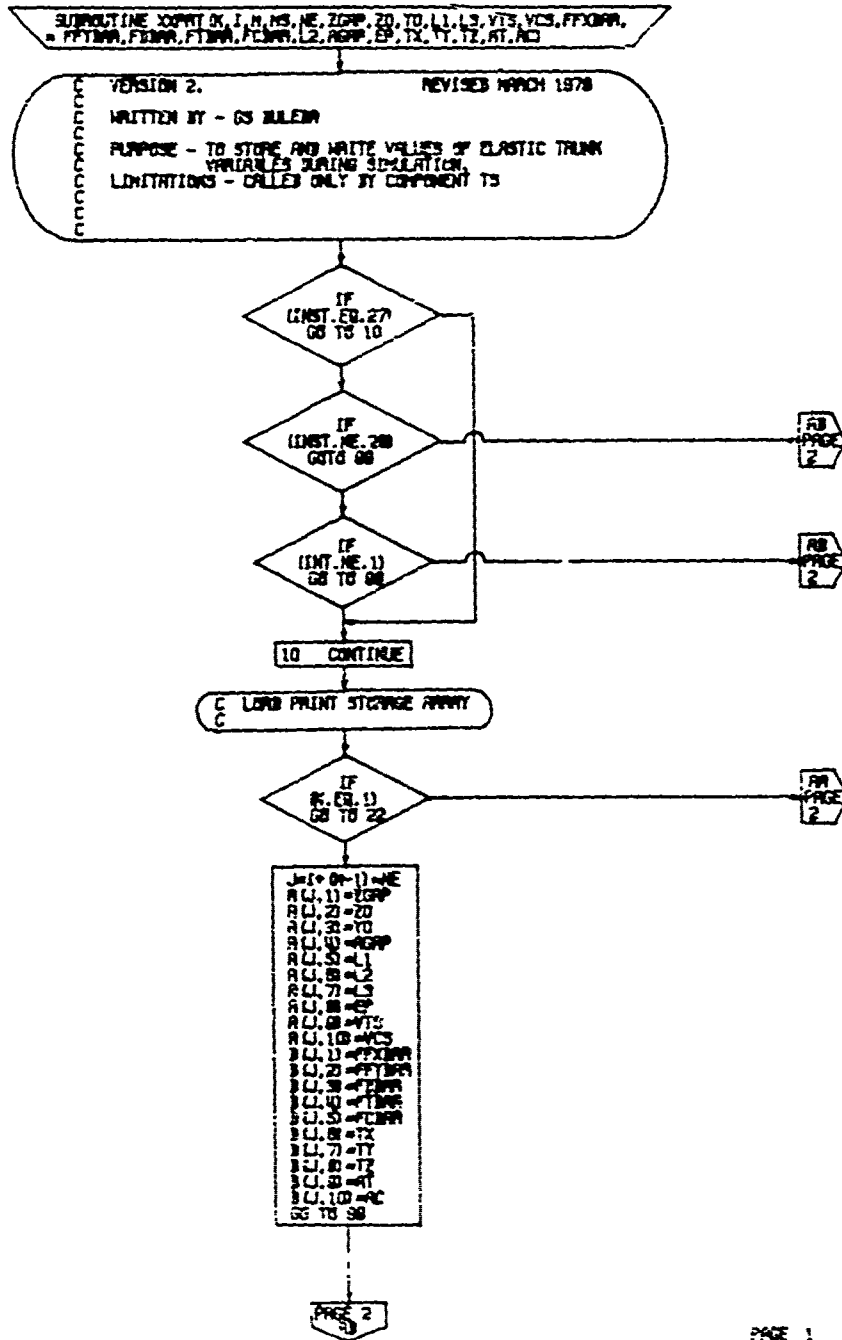

Table 126: FLOWCHART FOR SUBROUTINE XXPR1



PAGE 1
 XXPR1

Table 126: FLOWCHART FOR SUBROUTINE XXPR1 (CONCLUDED)

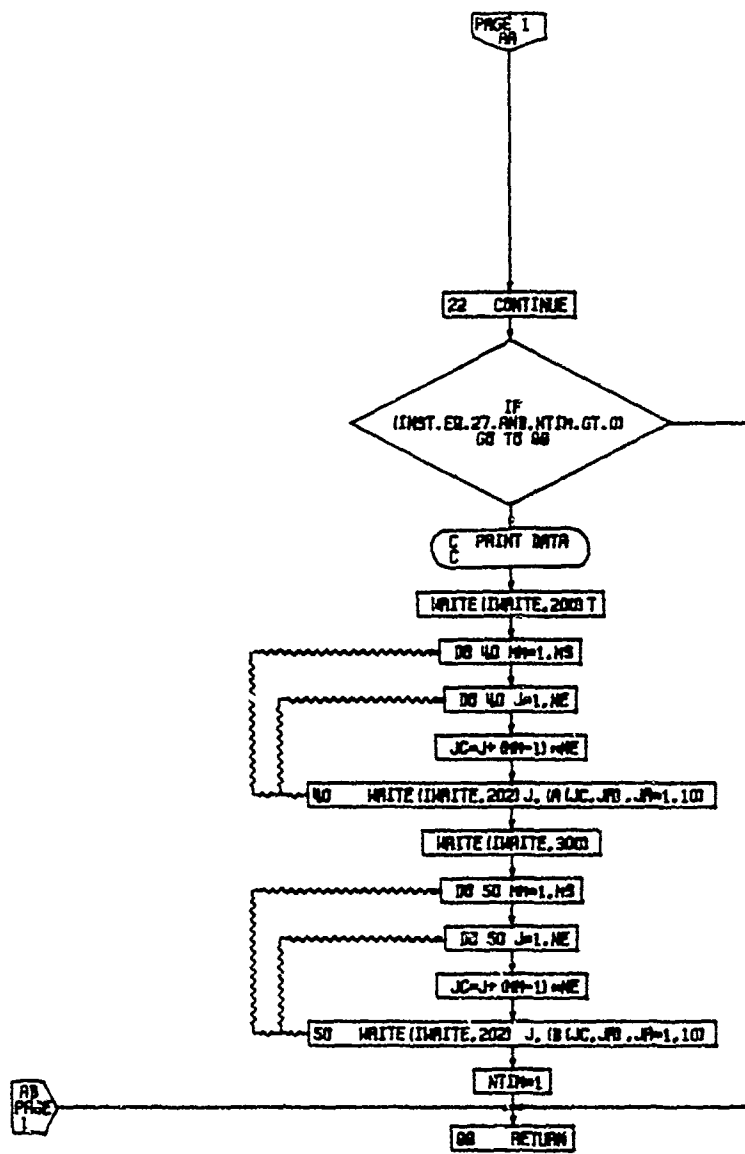
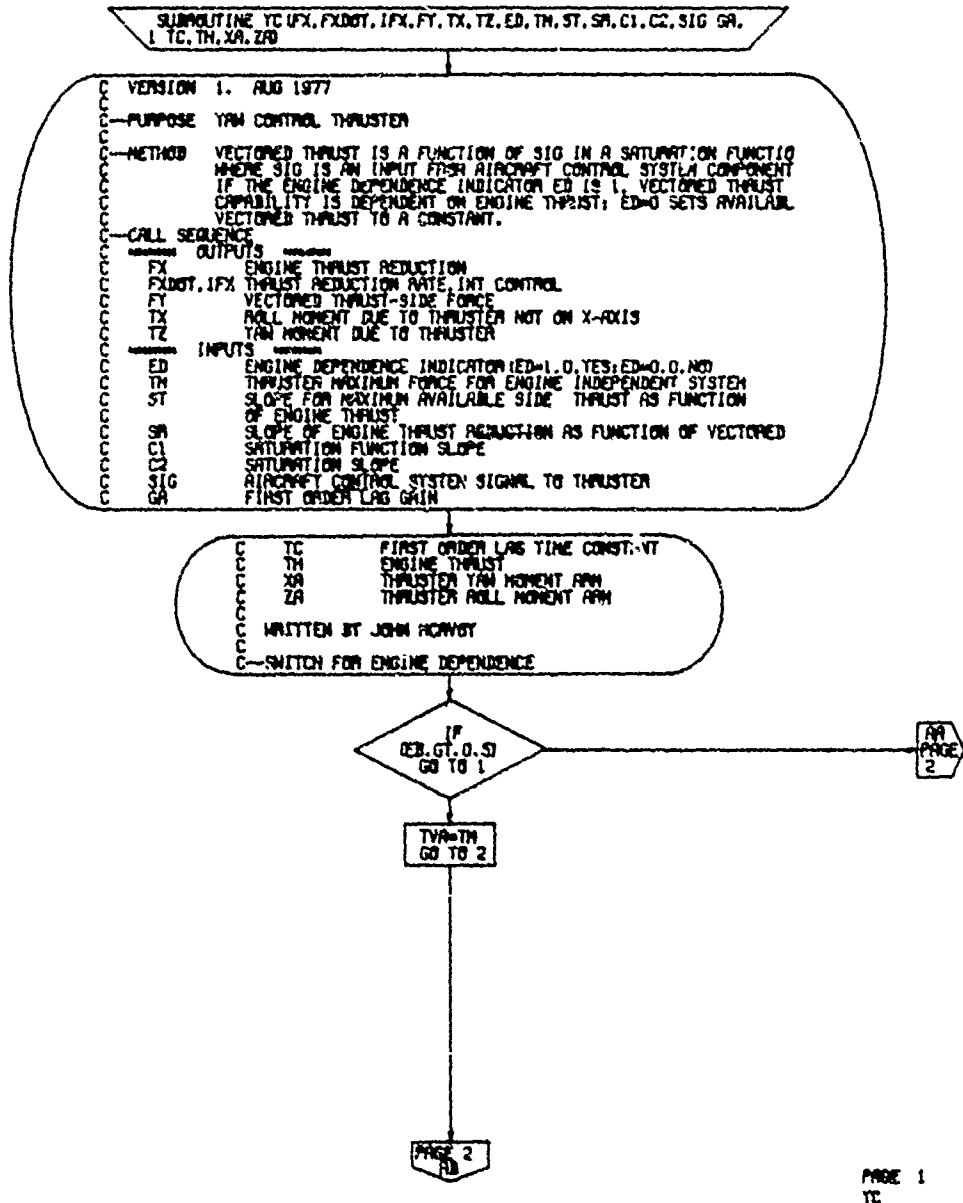

Table 127: FLOWCHART FOR SUBROUTINE YC



PAGE 1
TC

Table i27: FLOWCHART FOR SUBROUTINE YC (CONCLUDED)

