



Report No. FAA-RD-79-114

**LEVEL**

**12**

# STUDY OF OPTICAL TECHNIQUES FOR INDIRECT GENERATION OF RUNWAY APPROACH LIGHTS

James C. Bremer  
L. James Happel  
Ronald A. Parise

Operations Research Incorporated  
Silver Spring, Maryland 20910

DDC  
RECEIVED  
FEB 11 1980  
E



SEPTEMBER 1979  
Final Report

Document is available to the U.S. public through  
the National Technical Information Service,  
Springfield, Virginia 22161.

Prepared for

**U.S. DEPARTMENT OF TRANSPORTATION**  
**FEDERAL AVIATION ADMINISTRATION**  
Systems Research & Development Service  
Washington, D.C. 20590

DA080434

DDC FILE COPY

80 2 8 16

NOTICE

This document is disseminated under the sponsorship of the Department of Transportation in the interest of information exchange. The United States Government assumes no liability for its contents or use thereof.

Technical Report Documentation Page

1. Report No. <b>18</b> FAA-RD-79-114 <b>19</b>	2. Government Accession No.	3. Recipient's Catalog No. <b>11</b>	
4. Title and Subtitle <b>6</b> Study of Optical Techniques for Indirect Generation of Runway Approach Lights		5. Report Date September 1979	<b>14 ORI-7K</b>
7. Author(s) <b>10</b> James C. Bremer, L. James Happel, Ronald A. Parise		6. Performing Organization Code Technical Report No. 155	
9. Performing Organization Name and Address ORI (Operations Research Incorporated) Silver Spring, Maryland 20910		8. Performing Organization Report No.	
12. Sponsoring Agency Name and Address Department of Transportation Federal Aviation Administration Systems Research and Development Service Washington, DC 20590 <b>12 57</b>		10. Work Unit No. (TRAIS)	11. Contract or Grant No. WI-79-5327 <b>15</b>
15. Supplementary Notes		13. Type of Report and Period Covered <b>9</b> Final Rept. September '78-September '79	
14. Abstract The steel towers which are currently used to support runway approach lights present a significant collision hazard to landing aircraft, and are being replaced by frangible towers which reduce, but do not eliminate, this hazard. This study analyzes optical concepts for indirect generation of runway approach lights which would reduce the tower height or the mass of elevated components. Three concepts are investigated: projection of images with mirrors, use of a ground based lamp in conjunction with a diverging mirror in the light plane, and use of a fiber optic light pipe.  The projection of images can achieve a height reduction of several feet, but would require the construction and maintenance of large mirrors. The other two techniques could eliminate wiring from elevated structures, but would require more complex optics and higher levels of power consumption. None of these techniques appears to be practical when the marginal benefits are weighed against their complexity and cost.			
17. Key Words Airport Lighting Aids, Approach Lights, Runway Lights, Visual Aids for Airports		18. Distribution Statement Document is available to the public through the National Technical Information Service, Springfield, Virginia 22161	
19. Security Classif. (of this report) UNCLASSIFIED	20. Security Classif. (of this page) UNCLASSIFIED	21. No. of Pages 56	22. Price

270900

# METRIC CONVERSION FACTORS

## Approximate Conversions to Metric Measures

Symbol	When You Know	Multiply by	To Find	Symbol
<b>LENGTH</b>				
in	inches	2.5	centimeters	cm
ft	feet	30	centimeters	cm
yd	yards	0.9	meters	m
mi	miles	1.6	kilometers	km
<b>AREA</b>				
sq in	square inches	6.5	square centimeters	cm <sup>2</sup>
sq ft	square feet	0.09	square meters	m <sup>2</sup>
sq yd	square yards	0.8	square meters	m <sup>2</sup>
sq mi	square miles	2.6	square kilometers	km <sup>2</sup>
acres	acres	0.4	hectares	ha
<b>MASS (weight)</b>				
oz	ounces	28	grams	g
lb	pounds	0.45	kilograms	kg
	short tons (2000 lb)	0.9	tonnes	t
<b>VOLUME</b>				
sp	teaspoons	5	milliliters	ml
Tbsp	tablespoons	15	milliliters	ml
fl oz	fluid ounces	30	milliliters	ml
c	cups	0.24	liters	l
pt	pints	0.47	liters	l
qt	quarts	0.96	liters	l
gal	gallons	3.8	liters	l
ft <sup>3</sup>	cubic feet	0.03	cubic meters	m <sup>3</sup>
yd <sup>3</sup>	cubic yards	0.76	cubic meters	m <sup>3</sup>
<b>TEMPERATURE (exact)</b>				
°F	Fahrenheit temperature	5/9 (after subtracting 32)	Celsius temperature	°C

## Approximate Conversions from Metric Measures

Symbol	When You Know	Multiply by	To Find	Symbol
<b>LENGTH</b>				
mm	millimeters	0.04	inches	in
cm	centimeters	0.4	inches	in
m	meters	3.3	feet	ft
mi	meters	1.1	yards	yd
km	kilometers	0.6	miles	mi
<b>AREA</b>				
cm <sup>2</sup>	square centimeters	0.16	square inches	in <sup>2</sup>
m <sup>2</sup>	square meters	1.2	square yards	yd <sup>2</sup>
km <sup>2</sup>	square kilometers	0.4	square miles	mi <sup>2</sup>
ha	hectares (10,000 m <sup>2</sup> )	2.5	acres	acres
<b>MASS (weight)</b>				
g	grams	0.035	ounces	oz
kg	kilograms	2.2	pounds	lb
t	tonnes (1000 kg)	1.1	short tons	short tons
<b>VOLUME</b>				
ml	milliliters	0.03	fluid ounces	fl oz
l	liters	2.1	pints	pt
l	liters	1.06	quarts	qt
l	liters	0.26	gallons	gal
m <sup>3</sup>	cubic meters	35	cubic feet	ft <sup>3</sup>
m <sup>3</sup>	cubic meters	1.3	cubic yards	yd <sup>3</sup>
<b>TEMPERATURE (exact)</b>				
°C	Celsius temperature	9/5 (then add 32)	Fahrenheit temperature	°F

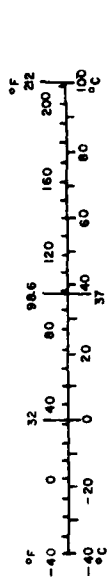
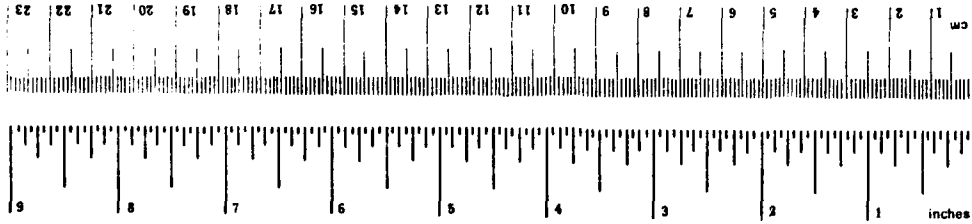

\* 1 in. = 2.54 (exactly). For other exact conversions and more detailed tables, see NBS Misc. Publ. 286, Units of Weight and Measures, Price \$2.25, SD Catalog No. C-310-286.

Accession For	
NTIS GRA&I	<input checked="" type="checkbox"/>
DOC TAB	<input type="checkbox"/>
Unannounced	<input type="checkbox"/>
Justification	<input type="checkbox"/>
By _____	
Distribution/	
Availability Codes	
Dist	Avail and/or special
A	

TABLE OF CONTENTS

	Page
LIST OF ILLUSTRATIONS	v
LIST OF TABLES	vi
I. INTRODUCTION . . . . .	1-1
1.0 PURPOSE AND SCOPE . . . . .	1-1
1.1 FUNCTIONAL DESCRIPTION OF RUNWAY APPROACH LIGHTS . . . . .	1-2
1.2 COLLISON HAZARDS DUE TO APPROACH LIGHT TOWERS . . . . .	1-3
1.3 POTENTIAL BENEFITS OF INDIRECT LIGHTING . . . . .	1-4
II. SELECTION AND EVALUATION CRITERIA . . . . .	2-1
2.0 SCOPE . . . . .	2-1
2.1 OPTICAL PARAMETERS . . . . .	2-1
2.2 IMAGE QUALITY AND STABILITY . . . . .	2-11
2.3 STRUCTURAL AND ENVIRONMENTAL FACTORS . . . . .	2-13
2.4 COST FACTORS . . . . .	2-14
III. CANDIDATE SYSTEMS . . . . .	3-1
3.0 SUMMARY OF OPTICAL TECHNIQUES . . . . .	3-1
3.1 PROJECTION OF IMAGES-VIRTUAL AND REAL . . . . .	3-1

TABLE OF CONTENTS (CONT)

3.2	DIVERGING ELEMENTS IN THE LIGHT PLANE . . . . .	3-14
3.3	LIGHT PIPE TECHNIQUE . . . . .	3-20
IV.	CONCLUSIONS AND RECOMMENDATIONS . . . . .	4-1
4.0	OVERVIEW. . . . .	4-1
4.1	CONCLUSIONS . . . . .	4-1
4.2	RECOMMENDATIONS . . . . .	4-2
V.	REFERENCES . . . . .	5-1

LIST OF ILLUSTRATIONS

Figure		Page
II-1	LAMP SHIELDING REQUIREMENTS FOR IMAGE PROJECTION SYSTEMS . . . . .	2-3
II-2	VERTICAL BEAM VISIBILITY ANGLES. . . . .	2-7
II-3	CENTRAL OBSUCURATION OF AN ON-AXIS REFLECTING IMAGE PRJECTOR. . . . .	2-9
III-1	PROJECTION OF REAL AND VIRTUAL IMAGES BY MIRRORS AND LENSES. . . . .	3-3
III-2	SPURIOUS IMAGE PRODUCTION BY SUN'S RAYS . . . . .	3-5
III-3	GEOMETRY FOR PROJECTION OF IMAGES. . . . .	3-7
III-4	TOP VIEW OF MULTIPLE IMAGE PROJECTION SYSTEM . . . . .	3-11
III-5	PROJECTION OF IMAGES OVER INACCESSIBLE TERRAIN . . . . .	3-13
III-6	DIVERGING MIRROR IN THE LIGHT PLANE. . . . .	3-16
III-7	SEGMENTED MIRROR TECHNIQUE . . . . .	3-18
III-8	LIGHT PIPE TECHNIQUE . . . . .	3-21

LIST OF TABLES

Table		Page
II-1	Vertical Angles for Runway Approach Lights. . . .	2-6
IV-1	Comparison of Alternative Approach Light Systems with Conventional Lamps on Frangible Towers . . . . .	4-3

## I. INTRODUCTION

### 1.0 PURPOSE AND SCOPE

Runway approaches are presently illuminated by lights supported on steel towers. Between 1965 and 1978 (inclusive), twenty-five serious accidents have occurred in the U.S. involving collisions of aircraft with these towers. Current plans call for the replacement of the steel towers by frangible structures to minimize the aircraft damage produced upon impact. This replacement of steel towers by frangible towers will require an estimated commitment of 77 million dollars.

The purpose of this study is to investigate alternative techniques for runway approach lighting to determine the feasibility of constructing a system which would present less collision hazard to landing aircraft. Candidate systems are defined in terms of existing specifications for runway approach lighting systems with respect to beam intensity, beam divergence, geometric fidelity of the light pattern, and structural stability. These configurations are then discussed in terms of size, maintenance, and cost (capital and operational).

The primary purpose of this study effort is to investigate means to minimize hazards to the aircraft produced by impact of the

aircraft with the supporting structures. Thus the ideal system would eliminate elevated structures altogether. If such techniques appear to be unfeasible, the next priority would be given to those techniques which could produce images with acceptable intensity and fields-of-view above the extent of the towers. These techniques would increase the separation between physical structures and the glide-path and thereby reduce the probability of impact by increasing the margin for error.

#### 1.1 FUNCTIONAL DESCRIPTION OF RUNWAY APPROACH LIGHTS

The Runway Approach Lighting System is a standardized configuration of lights located in proximity to an airfield for the purpose of providing a visual reference frame to the pilots of landing aircraft. A pilot must extract visual cues from this system to evaluate the position, attitude, and velocity of his aircraft. The approach lighting system is one component subsystem consisting of lights configured symmetrically about the runway centerline extending outward from the landing threshold into the approach zone. The approach light system contains a standardized array of constantly-illuminated lights forming an approach light plane. The pilot uses this plane to align the direction of motion of his aircraft along the runway centerline, and also to judge the correct altitude, descent angle, and roll alignment. A sequenced flasher consisting of a row of pulsed lights lies on the extension of the runway centerline in the approach zone. It provides a visual reference to indicate the location and direction of the approach path.

A rectangular area 400 ft. wide by 3200 ft. long is required for the full length systems, ALSF-1 and ALSF-2. Medium intensity systems also require the 400 ft. width but may be as short as 1500 ft.

The stationary lights are mounted on light bars approximately 13½ ft. long which are aligned parallel to the ground and perpendicular to the extended runway centerline. These bars are spaced at 100 ft. intervals beginning 300 ft. from the runway threshold. The bar located 1000 ft. from the runway threshold is supplemented by two 8-light bars to form a 21-light reference line parallel to the threshold.

The approach light plane should ideally be horizontal at the elevation of the runway centerline. No object may protrude above this plane, with the exception of the threshold bar and the red light bars located 100 ft. and 200 ft. from the threshold, which may protrude several inches and some Instrument Landing System (ILS) antennas. Some sloping segments are permitted, in the light plane, but are considered undesirable. Minimum clearance elevations over roads, railroads and vehicle parking areas are also specified. [1]

#### 1.2 COLLISION HAZARDS DUE TO APPROACH LIGHT TOWERS

The steel towers which are presently used to support most runway approach lights create a significant collision hazard to any aircraft which approaches the runway below the proper glide path envelope. Since the separation between the proper approach path and the approach light plane decreases as the landing aircraft nears the runway threshold, the innermost towers present the greatest hazard to landing aircraft. Any new runway construction requires the installation of frangible or semi-frangible lights between the runway threshold and the 1000-foot bar. Current FAA plans call for the replacement of existing steel towers by frangible towers.

Since commercial airliners typically touchdown at speeds of about 180 mph., even frangible towers can present a significant

impact hazard. In addition to the support structure, each lamp is encased in a metallic light assembly (usually cast aluminum) [2] and therefore impacts a colliding aircraft as a concentrated, nonfrangible mass.

### 1.3 POTENTIAL BENEFITS OF INDIRECT LIGHTING

The replacement of steel towers by frangible towers will be a major undertaking and will require an estimated 77 million dollars to complete. It is therefore worthwhile to investigate alternate methods of runway approach lighting before such a program is implemented.

The ideal system would be one in which the runway approach light could be generated without the use of elevated structures. In theory, a holographic projection technique could perform this function. Practically, however, a holographic technique is not feasible at present and does not appear to be viable in the near future. Laser-based systems will also be rejected because coherent light is not desirable.

A system which could produce sufficient intensity to be visible under worst-case conditions could also present an eye safety hazard to the pilot due to constructive interference of the wavefront. The conversion efficiency of electricity to coherent, continuous visible laser light is approximately 0.1% [3], more than an order of magnitude worse than that of incandescent lamps. The power consumption of a laser system would be prohibitive with state-of-the-art components. Laser systems also suffer from problems of cost, lifetime, and alignment sensitivity. Light-emitting diodes (LED's) at the present state-of-the-art cannot satisfy the intensity requirements. For these reasons, this study will be constrained to consider only conventional light sources, i.e. lamps of the incandescent or arc discharge variety.

Since it does not appear practical to eliminate elevated structures completely, using current technology, this study will investigate the safety improvements which can be made by reducing the collision dangers created by elevated masses. The elevated mass distribution may be improved by reducing the height of physical objects with respect to the light plane, by reducing the mass of elevated objects, or by reducing the concentration of mass in a small volume. (The benefits of the third approach may be appreciated by considering the analogy of a slap vs. a punch or a "karate chop"; the slap is least destructive because the hand's impact is distributed over a large area).

## II. SELECTION AND EVALUATION CRITERIA

### 2.0 SCOPE

This section will develop the criteria against which any candidate system must be evaluated. Certain optical characteristics along with geometrical, structural, environmental and cost parameters will be used as evaluation and performance criteria. The data compiled will then form the basis for the selection of a candidate system.

### 2.1 OPTICAL PARAMETERS

Optical performance is the primary consideration against which any proposed system must be evaluated. The images of lamps must be visible to a pilot anywhere within the specified envelope surrounding the glide plane. They must have adequate intensities, must appear to originate from points in the light plane, and must be stable. This optical performance requirement also implies a negative constraint that the light plane and its surrounding area must be free of any spurious sources of illumination which could confuse the pilot.

The field-of-view over which each light must be visible translates into beam divergence and aiming constraints upon the

illumination system. This geometry, in turn, specifies interrelationships among parameters such as the minimum dimensions of optical elements, the maximum separation distances, and orientations of components with respect to the light plane. Since the light plane must be free from spurious sources of illumination, any lamp which is used to generate displaced images must be shielded to obstruct all direct lines of sight between the lamp and the pilot's eyes. (This portion of the lamp's illumination should also be reflected into the image to maximize the energy efficiency of the system). The orientations of mirrors and lenses must also be constrained to prevent them from creating false images due to solar illumination. Stray light cannot be projected toward the pilot; light projected toward the runway is also undesirable but is far less critical (See Figure II-1). If beamsplitters are used, they must also be appropriately shielded. [4]

The positions of the lights perceived by the pilot in the frame of reference of the cockpit, provide a number of important cues:

1. Left/right symmetry of the light geometry is an indication that the aircraft flight path is properly aligned with the center line of the runway.
2. Horizontal alignment of the images indicates that the aircraft is approaching level flight altitude.
3. The vertical displacement between adjacent bars and the decrease in horizontal angular displacement of lights on more distant bars provide cues from which the pilot can judge his elevation and angle of descent.
4. The time dependent evolution of these cues provides the pilot with information about the dynamics of the aircraft; its velocity and its attitude.

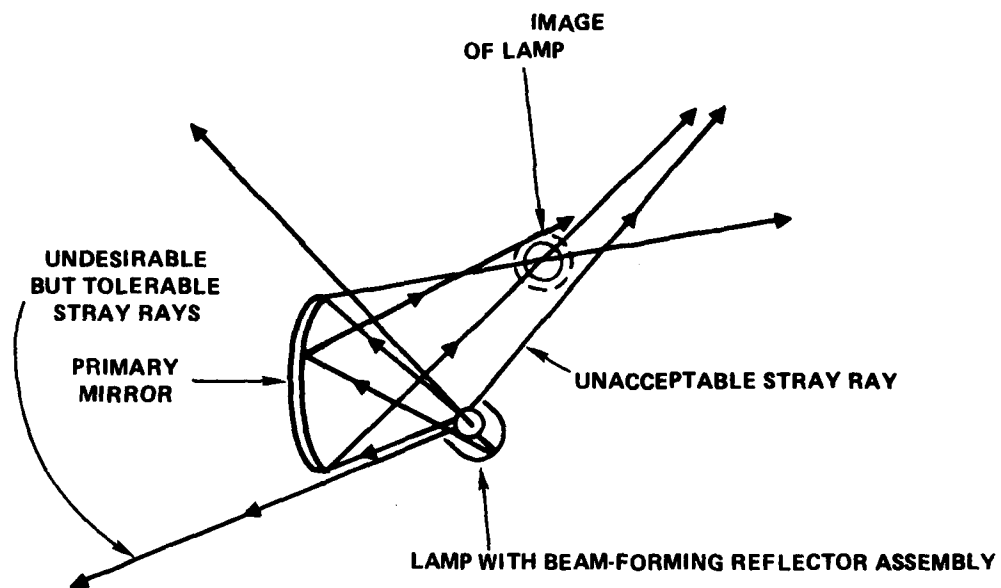

**Figure II-1 Lamp Shielding Requirements  
For Image Projection Systems**

### 2.1.1 Horizontal and Vertical Beam Divergence

The visibility criteria for runway approach lights are specified on page 11, paragraph 21-d of the FAA specification [1]:

"Visibility. There is a clear line of sight to all lights of the system from any point on a surface, 1/2 degree below the ILS glide path and extending 250 feet each side of the centerline, up to 1600 feet in advance of the outermost light in the system. For nonprecision systems, installed where there is no ILS, a 3-degree glide path, intersecting the runway 1000 feet from the landing threshold, is assumed for determining the visibility requirement."

The horizontal distance to this point from the aiming point is  $D + 2600$  ft. where  $D$  is the distance from the threshold to the outermost light of the system. At this horizontal distance, the minimum elevation angle from which this light must be visible is:

$$h = (D + 2600) \tan 2.5^\circ$$

For a lamp located  $S$  feet in front of the runway threshold, the minimum elevation angle for visibility is:

$$\theta_l = \arctan \left( \frac{h}{1600 + D - S} \right)$$

which becomes:

$$\theta_l = \arctan \left[ \frac{.04366 (D + 2600)}{1600 + D - S} \right] \quad (2-1)$$

The elevation angle of the beam axis may be computed from the aiming criteria specified on page 15, paragraph 26 [1]:

"Aiming. All lights, except semi-flush lights, shall be aimed vertically to a point on the glide path at a horizontal distance of 1600 feet in advance of the light. For nonprecision systems, a 3-degree glide path angle is assumed for aiming purposes. All lights in a bar shall be aimed at the same vertical angle."

The height at which the beam axis intersects the glideslope is:

$$h' = (2600 + S) \tan 3^\circ$$

And the elevation angle of the axis becomes:

$$\theta \text{ axis} = \arctan \left[ \frac{(2600 + S) \tan 3^\circ}{1600} \right]$$

Which is equivalent to:

$$\theta \text{ axis} = \arctan \left[ \frac{.05241 (2600 + S)}{1600} \right]$$

(2-2)

S	$\theta$ axis	D=1400		D=2400		D=3000	
		$\theta_{\ell}$	$\theta_{\mu}$	$\theta_{\ell}$	$\theta_{\mu}$	$\theta_{\ell}$	$\theta_{\mu}$
200	5.24	3.56	6.92	3.28	7.20	3.18	7.30
400	5.61	3.84	7.38	3.47	7.75	3.33	7.89
600	5.98	4.16	7.80	3.67	8.29	3.50	8.46
800	6.35	4.53	8.17	3.90	8.80	3.68	9.02
1000	6.73	4.99	8.47	4.16	9.30	3.89	9.57
1200	7.10	5.54	8.66	4.46	9.74	4.11	10.09
1400	7.46	6.23	8.69	4.80	10.12	4.37	10.55
1600	7.83			5.20	10.46	4.67	10.99
1800	8.20			5.67	10.73	4.99	11.41
2000	8.57			6.23	10.91	5.37	11.77
2200	8.94			6.91	10.97	5.82	12.06
2400	9.30			7.77	10.83	6.34	12.26
2600	9.67					6.97	12.37
2800	10.03					7.73	12.33
3000	10.39					8.69	12.09

Table II-1 VERTICAL ANGLES  
FOR RUNWAY APPROACH LIGHTS  
(distances in feet, angles in degrees)

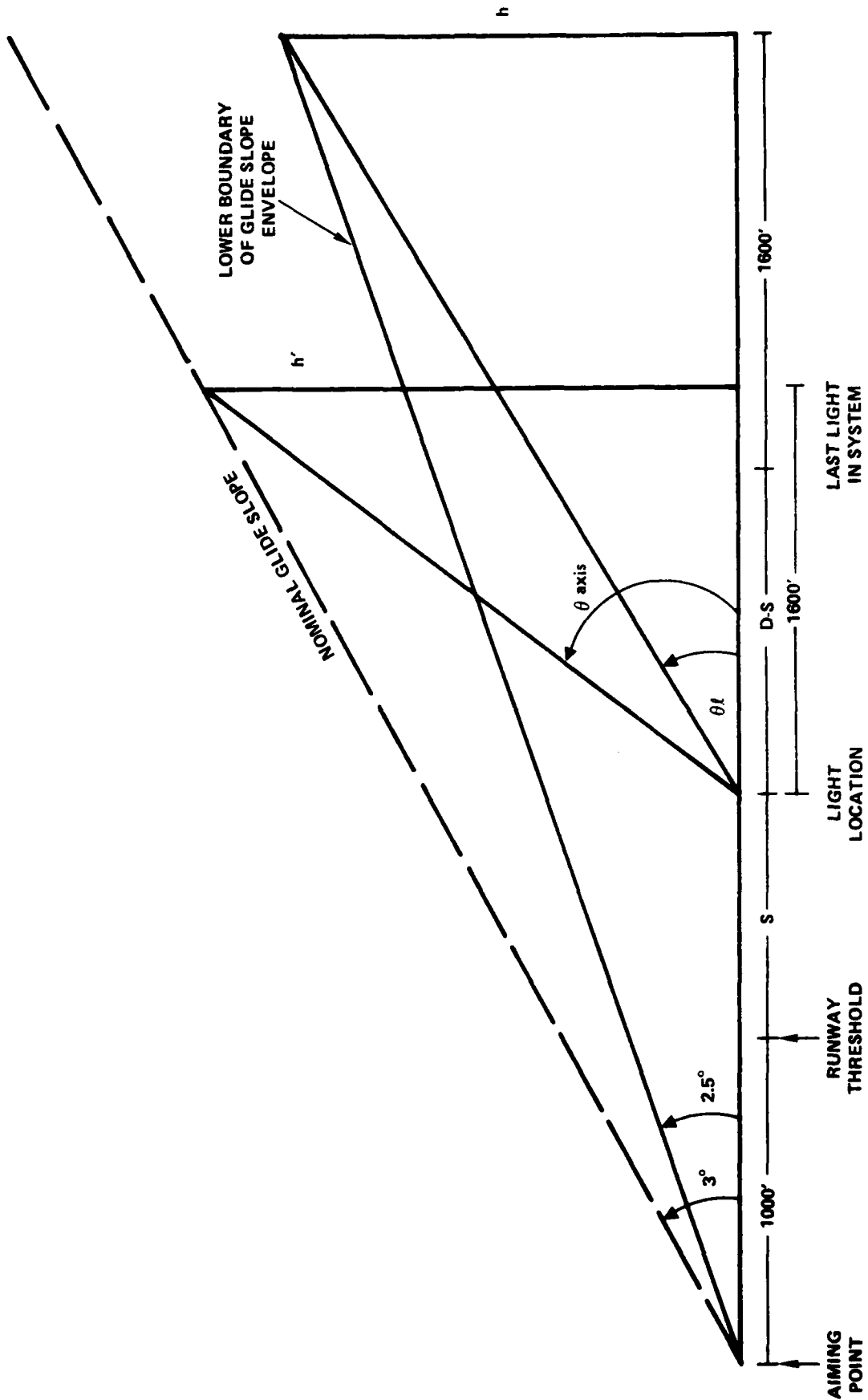

Figure II-2 Vertical Beam Visibility Angles

The geometry which determines these two vertical angles is illustrated in Figure II-2. Since the beam of the lamp is symmetrical about the axis, we may compute the maximum elevation angles of visibility,  $\theta_{\mu}$ , from the relationship:

$$\theta_{\mu} = \theta_{axis} + (\theta_{axis} - \theta_{\ell})$$

$$\theta_{\mu} = 2\theta_{axis} - \theta_{\ell} \quad (2-3)$$

The axis elevation angle and the minimum and maximum visibility angle are tabulated for standard runway lengths and selected light positions in Table II-1.

The horizontal beam divergence is specified by the requirement that the beam be visible 250 feet on either side of the centerline when viewed from a distance of 1600 feet in front of the light. The full-width horizontal divergence of the beam is therefore:

$$\theta_x = 2\arctan (250/1600)$$

and

$$\theta_x = 17.8^{\circ} \quad (2-4)$$

2.1.1.2 Central Obscuration. Optical telescopes which employ a concave mirror as their primary focusing element are generally fabricated in an on-axis configuration, i.e. the image and object both lie on the mirror's axis of rotational symmetry. For example, a Newtonian telescope which is focused at infinity uses a paraboloidal primary mirror and a small optical flat to extract the image (see Figure II-3-a). On-axis reflecting systems are subject to central obscuration; rays entering the telescope near the central axis will strike the back of the flat mirror and will therefore not reach the focal plane.

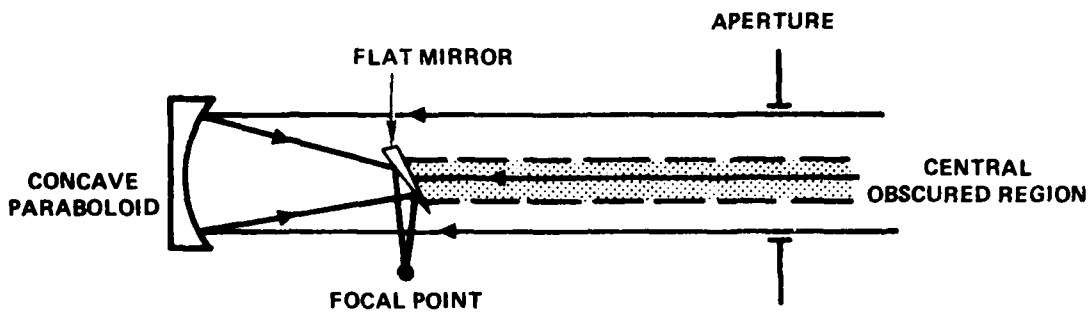

Figure II-3-a Newtonian Telescope

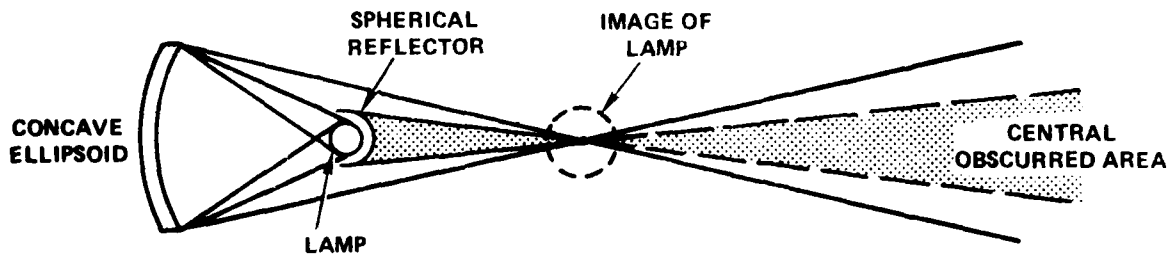

Figure II-3-b Central Obscuration of an On-Axis Reflecting Image Projector

In most telescopes, the obscured area is no more than 10% of the total aperture and the effects of the obscuration are undesirable but tolerable, namely a slight loss of intensity, a slight increase in diffraction, and a greater tendency to gather light from out-of-field sources into the image plane.

The effect of central obscuration is more troublesome in a reflective system designed to project images because it decreases the field-of-view over which these images are visible. Figure II-3-b illustrates an on-axis ellipsoidal mirror with a lamp at its near focus and its image (inverted and magnified by the ratio of the image and object distances) at its far focus. A small spherical reflector, centered on or near the luminosity center of the lamp, is used to increase the intensity of light striking the ellipsoidal mirror. This reflector blocks light which strikes the mirror in a small area close to the optical axis from contributing to the image and, consequently, the image is not visible within a small core centered about the optical axis.

## 2.2 IMAGE QUALITY AND STABILITY

### 2.2.1 Specification of Image Quality

The definition of the image quality and stability which are "good enough" is somewhat arbitrary, but there are guidelines which may be drawn. The upper bound on the performance specification (i.e. the point at which increased optical quality of the light-generating system would produce only negligible increase in the sharpness of the images) is dictated by the dimensions of the lamps. An error source which causes the image to be broadened or displaced by a small fraction of a lamp diameter is therefore acceptable. The lower bound on acceptable optical performance is dictated by the requirement that the images produced by the light-generating system should be distinct. In other words, a light bar consisting of five distinct lights separated by 40 1/2" should appear to the pilot as five distinct images and not a smeared "bar of light". Because of this requirement, any error source which would cause the image to be broadened to a diameter of 40 inches or displaced by 40 inches would clearly be unacceptable.

Based upon this analysis, we will set the following requirements for optical performance:

1. The apparent diameter of an image shall not exceed two feet.
2. The apparent position of an image, i.e. the centroid of the intensity distribution, shall not deviate from its proper geometric position by more than one foot.

### 2.2.2 Error Budget Factors

There are three basic problems in an image projection system: image blur, image position, and image intensity. In Section 2.2.1 we derived qualitative criteria for image blur and image position. More qualitative criteria (e.g. intensity distribution functions) are beyond the scope of this report. Image intensity will be required to equal that of the equivalent lamps in the appropriate lighting system (ALSF, MALS, etc.)

The following optical factors must be considered in evaluating the image quality and intensity.

1. Surface figures of optical elements
2. Reflectivities of optical surfaces.
3. Attenuation coefficients of refractive elements.
4. Accumulation of dust, snow, ice, and water droplets on optical surfaces.
5. Extinction along the light path between the lamp and the image. (The criterion refers only to the atmospheric path between the light source and the image because the attenuation between the image and the pilot's eye is not affected by the type of image projection).

The analysis of these systems is complicated by the fact that some of the optical parameters affect several of the performance factors. For example, accumulation of water droplets on a lens or mirror surface will decrease the integrated intensity of light in the image and will also blur that image. The structural

stability must be sufficiently great to maintain the required optical performance under ambient winds of up to 80 mph.\*

### 2.3 STRUCTURAL AND ENVIRONMENTAL FACTORS

The major goal of this study is to determine whether it is possible to build a light generating system with sufficient structural rigidity to maintain the optical quality of the images while presenting less collision hazard than the frangible towers.

Safety improvements may be made by one or more of the following means.

1. Reduced tower height
2. Reduced mass of elevated components.
3. Increased frangibility of elevated components
4. Elimination of concentrated, non-frangible objects (such as lamps) from elevated structures.

Thus the detailed evaluation of the safety of each system must be based upon a detailed analysis of the interaction of the height, mass, mass density and frangibility of its components. Additionally, wind and jet blast must be counteracted structurally. The system must be able to create the required images in ambient winds of up to 80 mph\* and must be able to survive jet blast intensities up to 350 mph [7]. If the system cannot rigidly withstand prevailing wind then the projected images will be shifting with respect to the runway centerline. This effect will result in false visual

\* Def. Private conversation author with Mr. John Semmerath

cues for the approaching pilot. If the system cannot withstand jet blast, then permanent deformation could occur after repeated landings thus creating an alignment and maintenance problem.

An indepth structural analysis would be required for any proposed system. Though such an analysis is beyond the scope of this report, items such as tower height, elevated mass and component frangibility will be considered.

#### 2.4 COST FACTORS

Certainly, cost is an important consideration throughout the entire study. Since the purchase of frangible light towers is a costly procurement, any cost saving afforded by an optical system would warrant consideration.

Though it is beyond the scope of this study to provide a detailed cost analysis of specifically identified lighting systems, components of the proposed systems which are considered cost drivers will be identified and addressed in a qualitative manner. Capital cost, operation and maintenance costs will be addressed.

### III. CANDIDATE SYSTEMS

#### 3.0 SUMMARY OF OPTICAL TECHNIQUES

This chapter addresses three concepts for the generation of runway approach lights: projection of images, diverging optical elements in the light plane, and light pipe techniques. The first technique, projection of images, uses concave mirrors to produce images above the height of the tower. The second technique, utilizes a beacon lamp on the ground to direct a collimated beam onto a mirror which reflects the light into the proper visibility cone. The third technique employs a fiber optic bundle to transfer light from a ground based lamp to the top of the tower.

#### 3.1 PROJECTION OF IMAGES - VIRTUAL AND REAL

##### 3.1.1 Configuration

The advantage of image projection is clearly that of reducing the height of an approach light tower. Both real and virtual images can be projected depending upon the type of mirror or lens used. Figure III-1 depicts four configurations for image projection. In Figure III-1-A, an ellipsoidal mirror is used. A real image is formed in front of the mirror when light from the lamp is converged by reflection from the concave mirror surface. When the mirror is

figured as a prolate ellipsoid and the lamp is placed at one focus, an aberration-free image will be formed at the other focus. An observer located within the cone of the rays diverging from this image will see the faithful three-dimensional replica of the lamp at this focus. This image will be inverted. This configuration provides potential to reduce the tower height because the image only needs to be visible at positive elevation angles. The optical axis is tilted upward and an off-axis mirror segment is used to avoid obscuration.

Another configuration which could potentially reduce the tower height is illustrated in Figure III-1-B. A convex lens may be used with the lamp placed on the optic axis beyond the focal point. Again tilting the optical axis upward will produce an image which is visible within a cone of positive elevation angles and whose height is greater than the height of any physical object. Figures III-1-C and D depict configurations which will not reduce potential tower height. In the former, a hyperboloidal mirror is used to produce a virtual image behind the mirror. The observer would see what appears to be an image of the light source while the actual light diverges from the mirror. The lens configuration in Figure III-1-D produces much the same effect with a virtual image produced behind the lens. Again, no height reduction would be possible due to the requirement that the image be visible at positive elevation angles. In fact, the mirror or lens would protrude above the light plane in violation of the study constraints.

Figures III-1-A and III-1-B depict two optical systems for producing the same elevated real image; III-1-A utilizes a mirror while III-1-B utilizes a lens. For a given set of geometrical parameters (cone of visibility, height saving, etc.) the dimensions and heights of the mirror and lens will be similar.

A mirror is generally lighter, less costly, and easier to maintain than a lens of equivalent aperture. Most of the disadvantages of lenses result from the fact that they achieve their

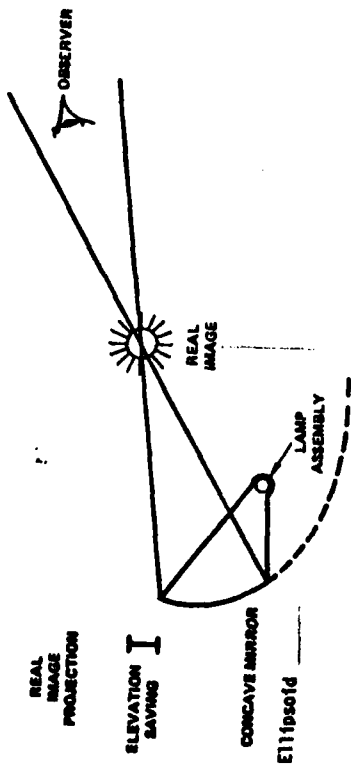

Figure III-1-A

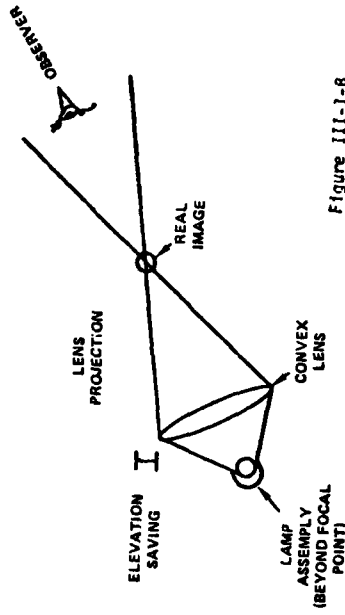

Figure III-1-B

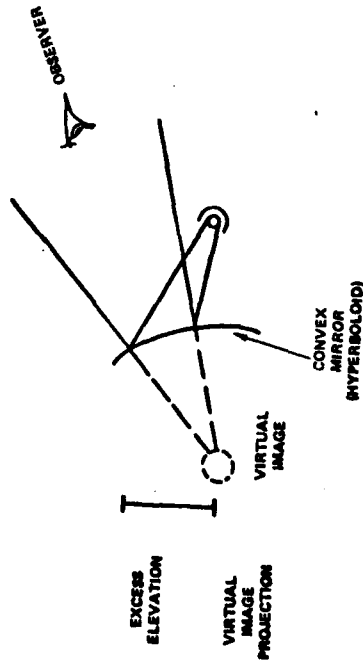

Figure III-1-C

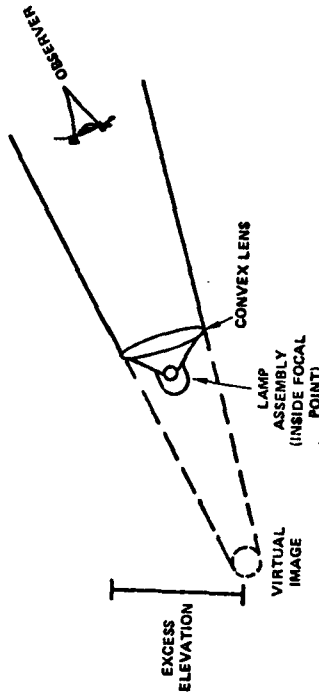

Figure III-1-D

Figure III-1 Projection of Real and Virtual Images By Mirrors and Lenses

optical power from refraction, a bulk effect, while mirrors achieve their optical power from reflection, a surface effect. A lens must have two well-figured surfaces and be free from internal defects if it is to achieve the desired optical quality. A mirror, on the other hand, needs only one well-figured optical surface. Since lenses must have substantial curvatures to achieve optical power, they must either be made thick (and therefore heavy) or must be figured as Fresnel lenses with facets.

Fresnel lenses are used in combination with reflectors in a large variety of lamps (e.g. automobile headlights, light house beacons, traffic lights, etc.) where their faceted surfaces may be enclosed. If the faceted surfaces are exposed to an adverse environment, however, they collect water and dirt more readily than smooth surfaces and the optical performance of the lens suffers accordingly. The faceted surfaces are also more difficult to clean than smooth surfaces. [5]

Mirrors have some disadvantages with respect to lenses but these are not critical for the proposed application. An off-axis segment of the ellipsoidal mirror (which is somewhat harder to fabricate than an on-axis mirror) must be used to avoid obscuration of a portion of the field of view. The mirror might also cause a spurious image to appear if it is illuminated by sunlight at a low elevation angle. (See Figure III-2)

As a result, the ellipsoidal mirror appears preferable to the lens and will therefore be considered as the candidate system for the projection of images above the light plane.

In all of these cases, it will be assumed that the light from the lamp is partially collimated by the lamp assembly so that it illuminates the entire surface of the mirror but directs as little light as possible in other directions. The lamp assembly would be very similar to conventional lamps in this respect.

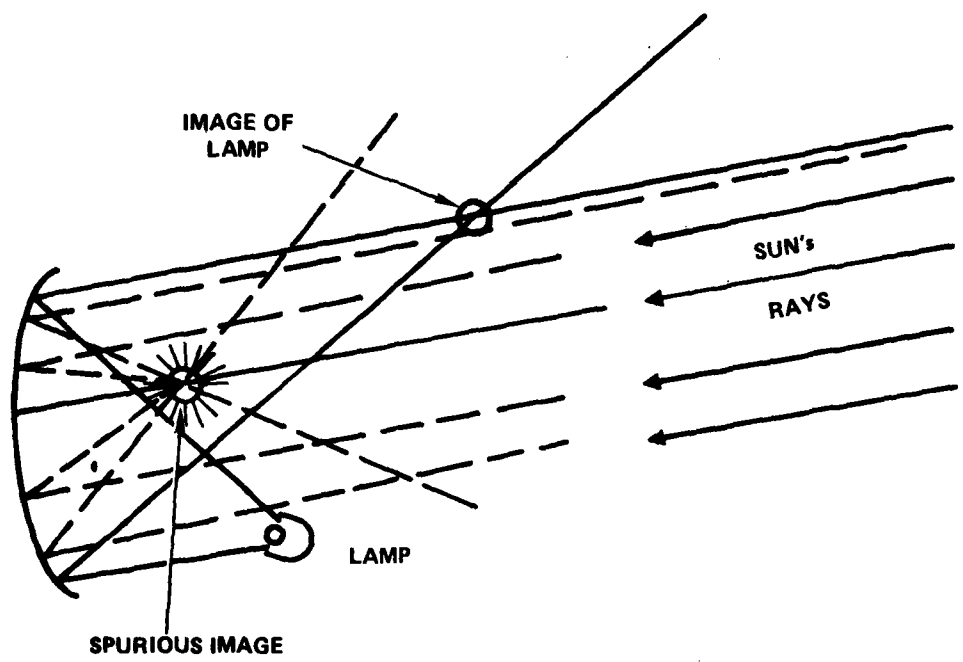

Figure III-2 Spurious Image Production  
By Sun's Rays

### 3.1.2 Analysis of Image Projection with an Ellipsoidal Mirror

A concave ellipsoidal mirror has two foci which are imaged into each other; i.e. light emitted by a compact source centered about one focus and reflected by the mirror's surface will converge to an image centered about the other focus. The image will be inverted and magnified by the ratio of the object/mirror separation distance to the image/mirror separation distance. An observer within the field of view of the reflected beam will perceive the light as originating at the image focus, as illustrated in Figure III-3.

A projection technique can produce images whose elevations are greater than those of the physical objects used to produce them. The approach light plane may therefore be elevated with respect to the maximum height of the approach light towers. This benefit will be achievable only if we restrict the light's visibility to positive elevation angles.

Some drawbacks associated with this projection technique are due to the relationships between the mirror size and orientation and the field-of-view. To quantify these relationships, we define parameters as indicated in Figure III-3. We have assumed that there is a left/right symmetry about the optical axis.

- $d_s$  = horizontal distance from source to mirror
- $d_i$  = horizontal distance from image to mirror
- $x$  = horizontal dimension of mirror
- $y$  = vertical dimension of mirror
- $h$  = height of image above top of mirror
- $\theta_x$  = horizontal field of view (full field)
- $\theta_l$  = lower elevation angle of vertical field of view
- $\theta_u$  = upper elevation angle of vertical field of view
- $\phi_x$  = horizontal beam divergence of lamp
- $\phi_y$  = vertical beam divergence of lamp

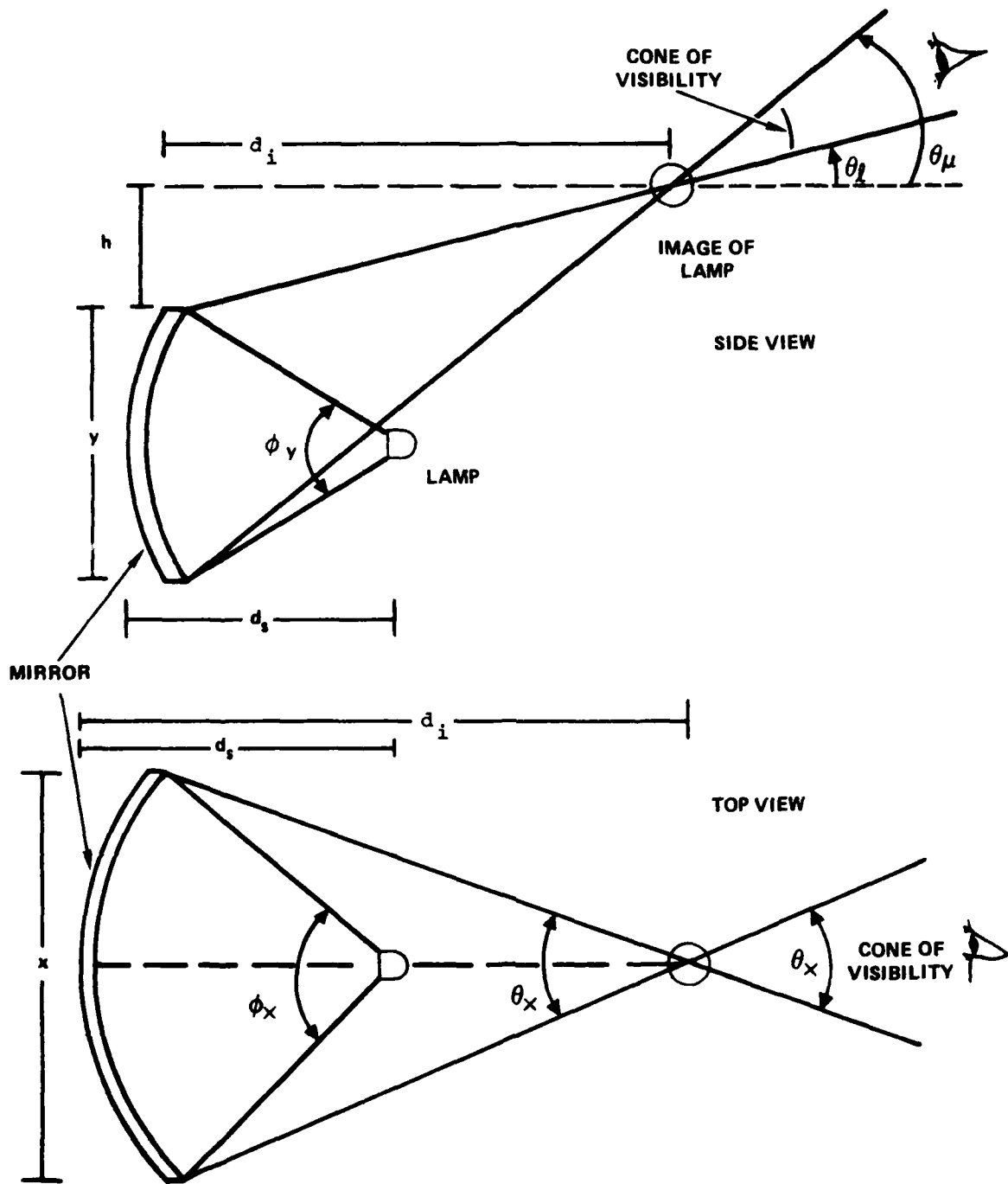

Figure 3-7 Geometry for Projection of Images

These parameters are interrelated by basic geometrical considerations. The height saving is:

$$h = d_i \tan \theta_l$$

The height of the mirror is:

$$y = d_i \tan \theta_u - h = d_i (\tan \theta_u - \tan \theta_l)$$

The horizontal dimension of the mirror is:

$$x = 2d_i \tan (\theta_x/2) = 0.3125 d_i$$

The horizontal divergence of the lamp beam should be:

$$\phi_x = 2 \arctan \left( \frac{x}{2 d_s} \right)$$

The vertical divergence of the lamp beam should be\* :

$$\phi_y = 2 \arctan \left( \frac{y}{2 d_s} \right)$$

We now consider the surface figure required to achieve the optical performance specifications that the light be diverted by no more than one foot from the correct image position. This translates into an angular pointing requirement of  $(1/d_i)$  radians. The misalignment of a mirror by a given angle produces a misalignment in the reflected beam which is twice as great so the surface figure has an allowable slope error,  $\delta$ , of  $(1/2d_i)$  radians or:

$$\delta = (28.6^\circ/d_i)$$

where  $d_i$  is measured in feet.

\*Because of the vertical tilt of the axis, this equation is approximate. It is sufficiently accurate for concept evaluation, however.

### 3.1.3 Sample Case Study

We now will consider the "best case" configuration with respect to height saving, i.e. the light with the largest minimum elevation angle,  $\theta_l$ . From Table II-1, it may be seen that the outermost light of a 3000 foot system satisfies this criterion. The critical values are:

$$D = 3000 \text{ feet}$$

$$S = 3000 \text{ feet}$$

$$\theta_l = 8.69^\circ$$

$$\theta_\mu = 12.09^\circ$$

We now compute the dimensions of a mirror configuration required to produce a height saving of six feet. The horizontal distance from the mirror to the image is:

$$d_i = 6 \text{ feet} / \tan (8.69^\circ) = 39.3 \text{ feet}$$

The height of the mirror is:

$$\begin{aligned} y &= 39.3 \text{ feet} [\tan (24.09^\circ) - \tan (8.69^\circ)] \\ &= 2.4 \text{ feet} \end{aligned}$$

The width of the mirror is:

$$x = 0.3125(39.3 \text{ ft}) = 12.3 \text{ feet}$$

The value of  $d_s$ , the distance from the mirror to the lamp, is a variable. It is advisable, however, to avoid high values of magnification. If we apply the criterion of Section 2.2 that the image diameter should not exceed two feet and consider a lamp size of six inches, then the maximum magnification will be four. For this magnification, the value of the lamp/mirror separation distance becomes:

$$d_s = d_i / 4 = 9.8 \text{ feet}$$

The average surface figure error must be less than:

$$\delta = 28.6^{\circ} / 39.3 = 0.73^{\circ}$$

The reflective surface finish of the image projection mirrors would not be critical. Commercial grade mirrors of back-surfaced glass or polished metal would be quite acceptable. The surface figure requirements would also be comparable to those of lamps, solar concentrators, etc.

Mirror blanks of this quality could probably be molded if a sufficient quantity were required. The mirrors could also be made by deforming plane mirror segments. As the projection distance is increased, the light must be collimated more precisely to maintain discrete images of the individual lamps and the optical figure requirements therefore become more stringent.

#### 3.1.4 Generation of Light Bar Image with a Single Mirror

A light bar consisting of five lamp images with 40.5" separation between adjacent lamps could be generated with a single mirror under certain conditions. The width of the mirrors would have to be 4x40.5" or 13.5 feet greater than the width of a single mirror. A single mirror would result in some aberrations of the off-axis images, but the size of the lamp would be tolerable for large values of  $d_1$  and  $d_s$ . This concept is illustrated in Figure III-4.

#### 3.1.5 Environmental and Maintenance Factors

The major environmental requirement which must be satisfied is that the mirror must be able to withstand a 350 mph jet blast. [7] In addition, it must be operational in the normal outdoor environment of wind, precipitation, thermal cycling, and sun exposure. Dust deflectors may be required to minimize contamination of the mirror surfaces by exhaust residues and by wind driven dust. Periodic cleaning of the mirror surfaces will be an important maintenance consideration.

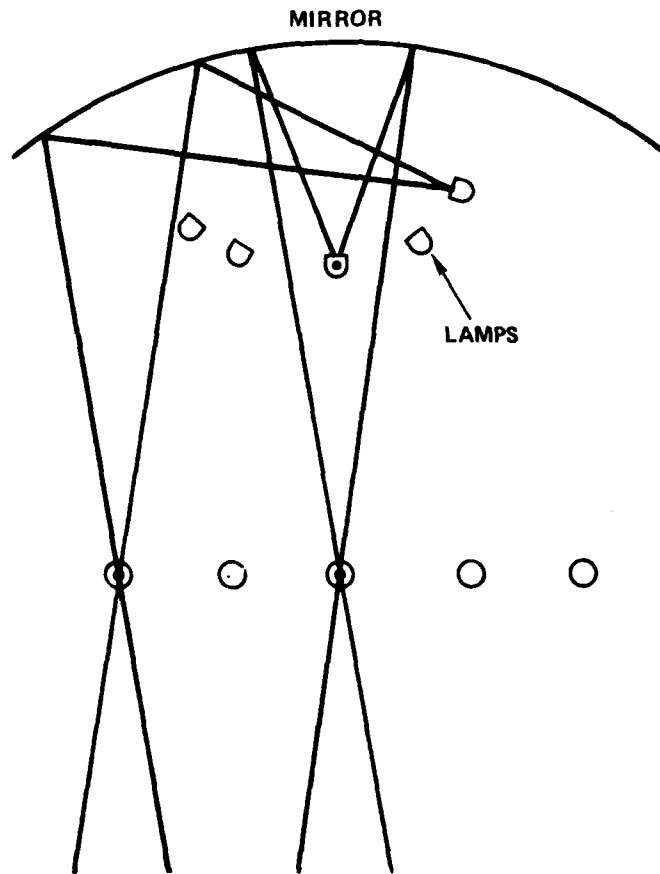

Figure III-4 Top View of  
Multiple Image Projection System

One implementation problem area which would require further investigation is that of sun glint and spurious reflections. Sun glint would only occur at certain aircraft attitudes and positions in the landing pattern. Certainly, mirrors facing a northerly direction would not be subject to this problem. At night, interfering reflections may occur when aircraft are using their landing light systems. Careful consideration must be given in the positioning of the mirror to eliminate both reflective problems.

Weather problems may degrade the performance of the system. Snow or freezing rain will coat the mirror surface and possibly degrade the optical qualities of the system. Since the lamps will not be installed close to the mirrors, heaters may be required to melt ice and snow from the surface. Rainfall should not present a significant problem.

#### 3.1.6 Advantages/Disadvantages

The major advantage of this system is that tower height can be reduced several feet. One situation which may be particularly suited for this image projection technique is that of providing approach lights over inaccessible areas.

Highways, rivers and ravines complicate the installation of a runway approach light system. Obviously, these situations do not provide a suitable environment for the construction of light towers. It may be possible, however, to project the light image over the inaccessible area as shown in Figure III-5. The field-of-view may become somewhat restricted due to the separation distance requirements. Such a trade-off would require additional study. One serious drawback is that the cost of the system may not be justified considering the height saving which can be realized. Additionally, mirror size could become quite significant due to the field-of-view requirements.

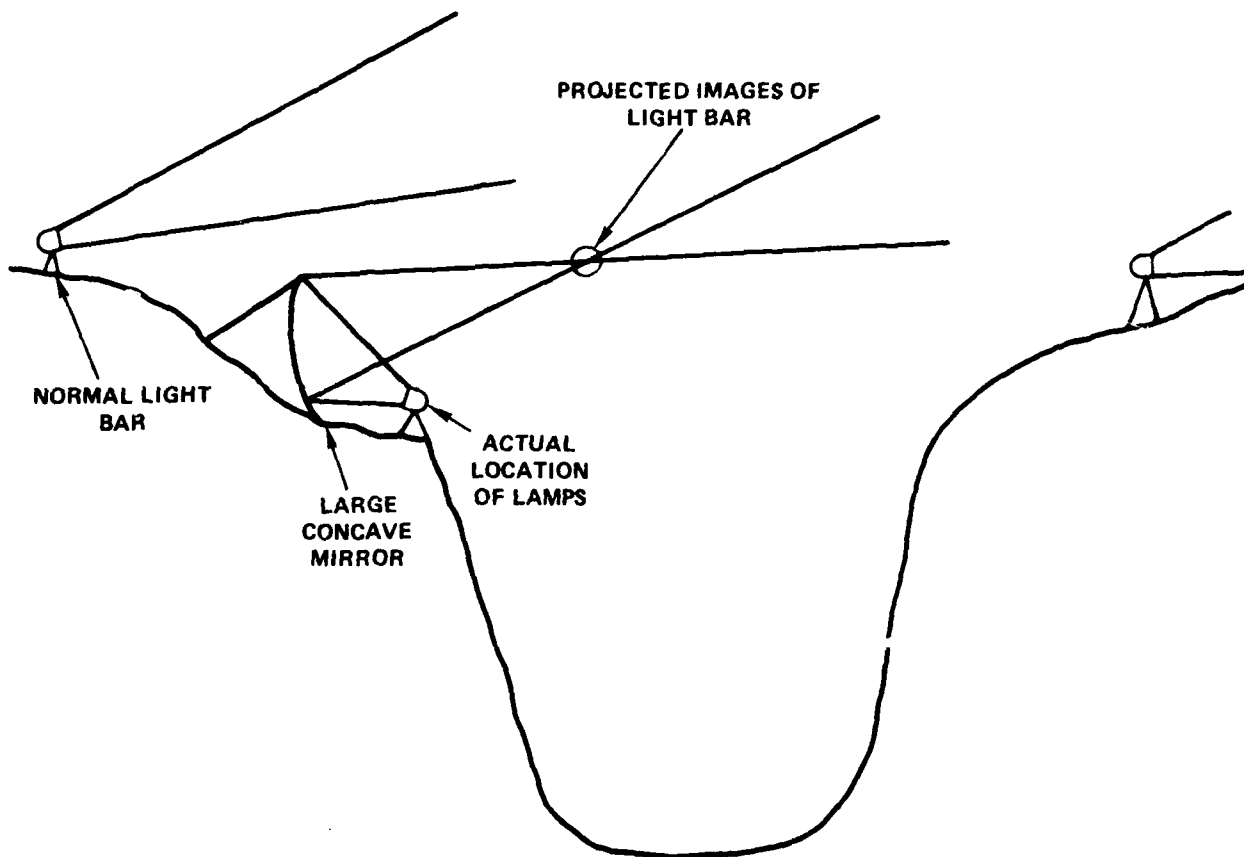

Figure III-5 Projection of Images  
Over Inaccessible Terrain

## 3.2 DIVERGING ELEMENTS IN THE LIGHT PLANE

### 3.2.1 Basic Configuration

The projection of images permits a reduction in the height of physical structures, but at the price of requiring large mirrors for a relatively small decrease in tower height. When the angular field-of-view of the light is specified, the mirror dimensions are proportional to the distance between the mirror and the image. The lamp, on the other hand, can be displaced from the mirror without requiring an increase in the size of the mirrors. It is therefore worthwhile to consider a variation of the image projection system in which the separation between the mirror and the image is small, but the light is located on the ground (which may be a substantial distance away from the mirror). This configuration does not result in any significant reduction of the tower height, but it does eliminate the need for lamps and electrical wiring on elevated structures. Removal of the electrical wiring from the elevated structures will increase their frangibility and removal of the lamps will eliminate the collision hazard due to their concentrated non-frangible mass. [6]

A collimated or nearly collimated beam must be projected upwards to strike a mirror or lens located on the top of a tower. It is desirable to minimize the separation between the lamp on the ground and the diverging optical element by projecting the beam vertically upward from a lamp located near the base of the tower (minimization of this separation distance between lamp and mirror is desirable to maximize the optical efficiency and to minimize the alignment sensitivity problem). Since the diverging cone of light must be aimed approximately ten degrees above the horizon the light from the beacon must be deflected, on the average, about 80 degrees.

A refractive system would require very thick lenses to refract the light by this amount, so a reflective system is preferable. We will therefore consider a configuration in which a collimated beam is projected vertically upward to strike a paraboloidal mirror. This mirror is an off-axis segment of a paraboloid whose vertex lies at the position of the image and whose axis is parallel to the beam of collimated light.

Figure III-6 depicts a paraboloidal mirror with a collimated light source. The overall structure height will be slightly reduced since the projected image would be slightly above the mirror. The overall height reduction will not be significant, however.

The collimated source need not be highly specialized. A small searchlight could be used as the ground-based source of collimated light. The quality of the beam-diverging mirror would not be critical.

### 3.2.2 Structural Factors

The towers required to support the diverging mirrors would be similar to those required to support the conventional runway approach lamps. Although a small height saving (up to a foot, perhaps) could be achieved, the primary safety benefits would be the elimination of the concentrated, non-frangible masses of the lamp housing assemblies and the increase in tower frangibility due to elimination of elevated electrical wiring.

The main structural stress in such a system is produced when wind and jet blast exert force upon the large cross-sectional area of the mirror. One way to minimize this problem (without constructing a massive mirror support system) is to segment the mirror. Figure III-7 illustrates a diverging element comprised

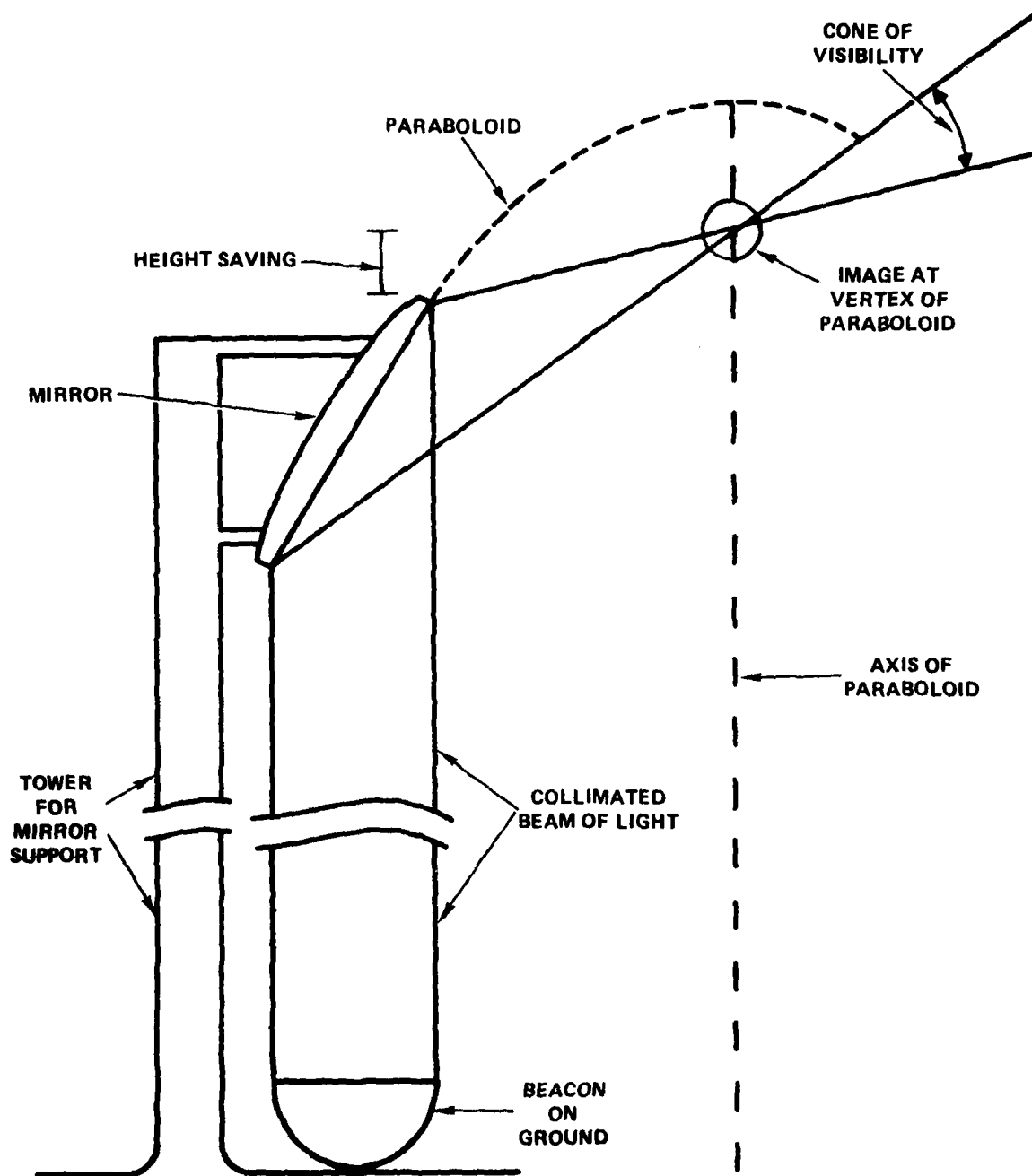

Figure III-6  
Diverging Mirror in the Light Plane

of several segmented mirrors. These mirrors are segments of two paraboloids which are figures of revolution about a common axis and have a common vertex on this axis where the image is formed. The mirrors subtend complementary radial segments of the horizontal field-of-view and thereby cover the visibility cone without requiring a single mirror of large cross-sectional area.

Alignment of the beam so that it strikes the mirror is another structural problem; the light must be pointed accurately and the tower must sufficiently rigid to maintain the mirror within the beam of the lamp. The entire surface area of the mirror must be illuminated to produce an image which is visible within the specified range of angles. For reasons of optical efficiency, it is desirable to make the beam as narrow as possible, minimizing the quantity of wasted light which misses the mirror and continues vertically upward. (This light will not confuse the pilot because the cockpit blocks his view in the nadir direction).

The alignment problem becomes increasingly severe as the tower height becomes greater. In the first place, the angular tolerance in the pointing of the optical beacon is inversely proportional to the lamp/mirror separation distance. Additionally, the positional excursions of the mirror become greater with increasing tower height.

These factors will place a practical limit on the tower height for such a system.

### 3.2.3 Advantages/Disadvantages

The major advantage of this method is the removal of concentrated mass from the tower by placing the light source on the ground. This results in a very frangible structure with no

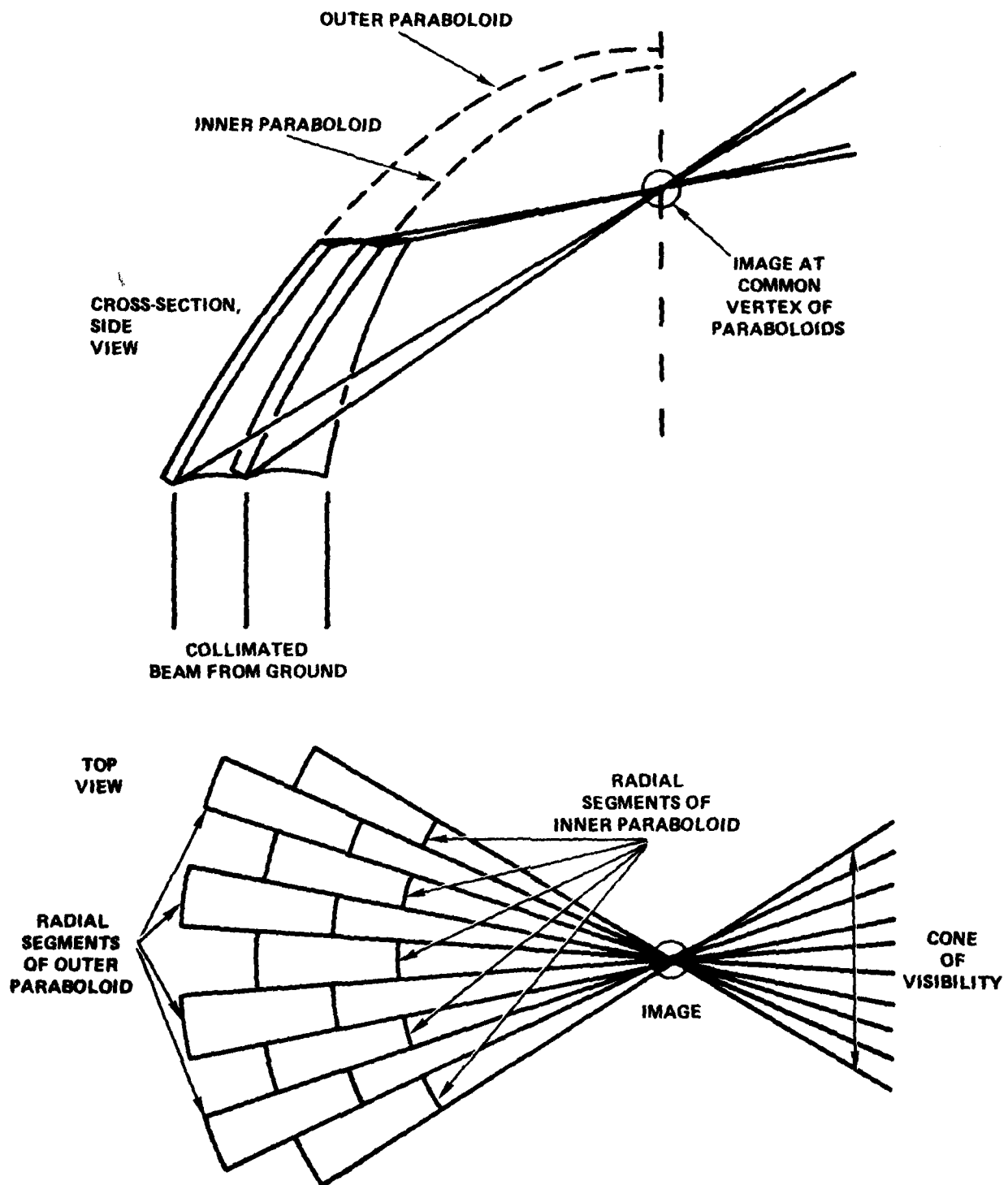

Figure III-7  
Segmented Mirror Technique

internal wiring. In addition, the lack of concentrated mass atop the tower would result in less aircraft damage. Lamp maintenance would also be simpler since it would be readily accessible on the ground.

Two major difficulties exist with this configuration. In adverse weather conditions, the collimated beam would scatter considerably and may cause confusion for approaching aircraft. Shielding may be required and would warrant further investigation. The second problem is alignment maintenance. A trade-off would be required between a structurally rigid and therefore massive support with a narrow optical beam and a lighter structure with lower optical efficiency.

### 3.3 LIGHT PIPE TECHNIQUE

#### 3.3.1 Advantages and Drawbacks

The advantages of using fiber optic bundles to transmit the approach light beam from a remote source to the light plane (as illustrated in Figure III-8) are two-fold.

- 1) The element which is mounted on the elevated structure in the light plane is replaced by a small lightweight container to protect the fiber optic bundle termination from the weather. This has the effect of not only presenting a lower mass to impacting aircraft but also may allow the frangible tower structures to maintain sufficient rigidity with lower mass.
- 2) Since the actual light sources are mounted on the ground no electrical lines are required on the tower. This eliminates the possibility of electrically ignited fires on impacting aircraft and increases the frangibility of the towers.

The major disadvantage to a configuration such as this is its poor efficiency. The three primary sources of loss in this system are the coupling of the light into the bundle, the attenuation in the bundle itself, and coupling the beam out of the bundle.

#### 3.3.2 Efficiency of a Fiber Optics System

The losses which are incurred in coupling into the bundle are the result of two effects. The most important of these being the fact that the total cross-sectional area of the bundle contains not only optical fiber ends but also the bonding material used in

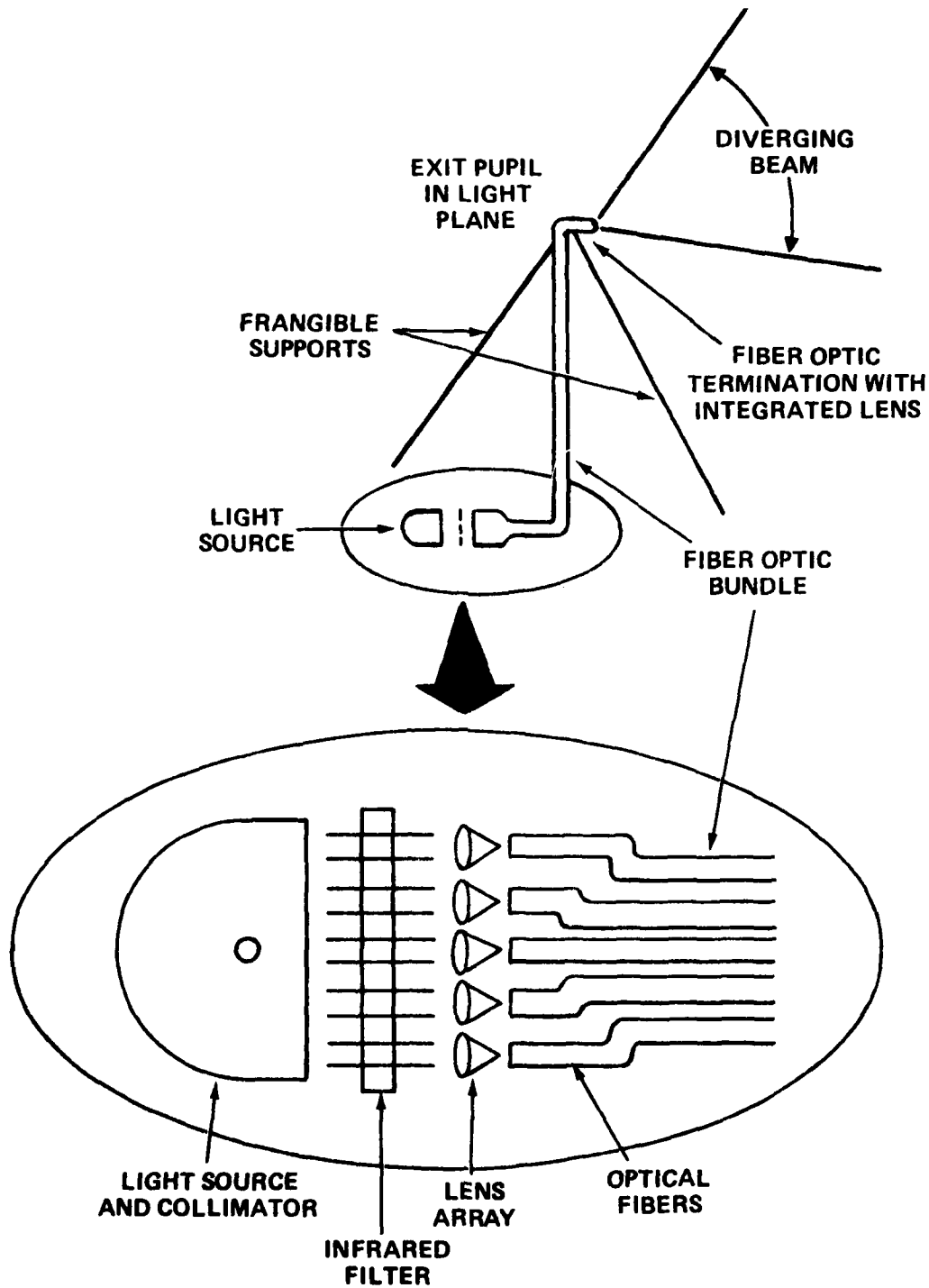

Figure III-8 Light Pipe Technique

manufacturing the bundle. Furthermore, each optical fiber consists of a light transmitting core, encased in a cladding, which does not transmit light.

Only those rays which encounter the wall of the optical fiber at an angle greater than the critical angle will be propagated down the fiber. This defines a maximum acceptance angle at the end face beyond which the rays are lost through the wall. Maximum efficiency is therefore obtained by illuminating the end of the bundle with a beam which converges at an angle less than the maximum acceptance angle. Reflective losses at the interface between the bundle end and the air add several more percent resulting in a total loss of approximately 30% or 1.5 dB.

By far the most important source of loss in this system is direct attenuation in the bundle itself. This is typically on the order of 8% per foot or 3 dB for every 8 feet of commercial grade fiber.

A lower loss bundle is available in what is termed communication grade fiber. Unfortunately these are available only in single fiber or very small diameter bundles making it very difficult to efficiently couple into it with a large light source. These high quality bundles are also considerably more expensive than equivalent sized commercial grade bundles.

The output end of the fiber bundle would have a slightly different loss due to the bonding of the lens to the face of the bundle. This would be a function of the bonding material used but would remain roughly the same as the source end or 1.5 dB.

In combining these losses for a typical situation consider a system in which the average fiber optic bundle length is 24 feet. This results in 9 dB of attenuation plus 3 dB of end loss

for a total of 12 dB for each light. In terms of purely operational costs this translates into a 16 fold increase in the amount of light required at the source in order to maintain the current intensity levels in the light plane.

Although manufacturing costs for fiber-optic bundles have decreased considerably over the past few years, a 1/2" diameter bundle 24 feet long still costs about \$800. In a typical ALSF approach system, there are potentially 250 lights which might be mounted on elevated structures. Again, assuming 24 feet of fiber optics per light, an initial investment of \$200,000 is required just to obtain the necessary fiber optics. This is, of course, in addition to the high intensity light sources and frangible tower assemblies which are required.

A specially designed lamp housing would be required to couple light efficiently into the fiber optic bundles. This lamp housing must be able to image a source of sufficient intensity on the fiber optic bundle termination to provide the requisite illumination in the light plane. An infra-red shield is also needed to prevent excessive heating of the fiber optic termination.

### 3.3.3 Light Sources

The two possible classes of light source which might be considered for this application are arc lamps and incandescent lamps.

An arc lamp has the advantage of providing a very intense and very compact luminous region which is easily imaged on the end-face of the fiber optics. It has the disadvantage of requiring several kilowatts to trigger the lamp initially. High voltage power supplies are not only dangerous but are also notoriously unreliable in an outdoor environment. A major operational

problem with arc sources in this application is the long warm-up time. Most arc lamps require a typical warm-up period of about one minute to achieve full intensity. In low traffic facilities, where the approach lighting system is activated upon request from incoming traffic, the warm-up time may be dangerously long for a pilot requiring an immediate visual reference. These problems, coupled with the relatively short useful life of the lamps, make them undesirable for this application.

Incandescent lamps, on the other hand, are available for low voltage applications. They also require no trigger voltage, no warm-up time and are considerably less expensive than equivalent arc sources. The useful life of an incandescent source is typically 10 times that of an arc source making them much more economical.

## IV. CONCLUSIONS AND RECOMMENDATIONS

### 4.0 OVERVIEW

The techniques analyzed in this report are capable of providing a reduction in tower height or of decreasing the mass of elevated components of a runway approach light system. There is, however, a large cost in terms of construction, operation and maintenance which must be paid to achieve a relatively minor reduction in the collision hazard.

Additionally, frangible towers would still be desirable meaning that the cost of any optical system would be in addition to the cost of frangible tower construction and installation.

### 4.1 CONCLUSIONS

It would be possible to achieve some reduction in the height of runway approach light towers with an image projection system employing large concave mirrors. Likewise, it would be possible to eliminate elevated lamps or electrical wiring by utilizing a ground based lamp and transferring its beam to proper the light cone with either a diverging mirror or a fiber-optical light pipe.

All of the above mentioned systems are more complex than the conventional system which employs lamps mounted on frangible towers. Consequently both their capital construction costs and their operational costs (including power consumption and maintenance) are larger than those of the conventional systems. The coupling and transmission losses of a light pipe comprised of commercial-grade optical fibers lead to prohibitive levels of power consumption. Mirror based systems require additional maintenance to clean the mirror surfaces. Furthermore, their structural strength must be sufficiently great to maintain the proper optical alignment. These factors are summarized in Table IV-1.

It is the conclusion of this study that installation and operation of any of the candidate optical techniques, outlined herein, would be impractical and excessively costly when compared to a frangible tower approach light system.

#### 4.2 RECOMMENDATIONS

Though the optical techniques outlined in this report are not recommended for fixed wing aircraft approach light systems, they may find practical application as approach aids for helicopter pads. It appears that helicopter landing sites lack extensive visual queing aids for night approaches. The helicopter approach problem is not as critical as the fixed wing aircraft since the helicopter can approach at much slower speeds and can utilize a great variety of glide slope angles. It is recommended, however, that the FAA consider the helicopter approach problem in light of this report to improve the visual aids available for night operations. This concept may have special significance for 1) High traffic density airports by allowing for more expeditious approaches of incoming helicopters 2) rooftop applications where there may be many vertical obstructions in the vicinity of the landing pad.

Comparison of Alternative Approach Light Systems  
with Conventional Lamps on Frangible Towers

Systems Factors	Projection of Images	Diverging Elements Light Plane	Fiber Optic Light Pipe
Benefits	Tower height reduction; Horizontal projection capability	Elimination of lamps and electrical wiring from elevated structures; small height reduction	Elimination of lamps and electrical wiring from elevated structures
Performance problems	Spurious images due to reflect- ion of sunlight, etc.	Alignment sensitivity; force of wind and jet blast on mirrors; Light scattering from collimated beam	
Major Capital costs	Large mirrors		Optical fiber bundles, Optics to couple source into optical fibers
Major operational and mainten- ance costs	Maintenance of clean surfaces on large-area mirrors	Alignment mainten- ance; cleaning of mirror surfaces Slightly greater power consumption	Prohibitive levels of power consumption

Table IV-1

## V. REFERENCES

1. Visual Guidance Lighting Systems, Department of Transportation, Federal Aviation Administration, 6850.2, (May 29, 1969, amended August 27, 1975), Ch 1-2.
2. Medium Intensity Approach Lighting System with Runway Alignment Indicator Lights (MALSR), Department of Transportation Federal Aviation Administration, FAA-E-2325C, (March 24, 1976), p 7.
3. Buzzard, Robert J., "Gas Lasers for Recording and Information Handling," Optical Engineering, Vol 15, No 2, p 79, Fig. 3.
4. Spooner, A. Michael, "Collimated Displays for Flight Simulation," Optical Engineering, No 3, Vol 15, (1976) pp 215-219.
5. Hackney, CDR. Robert V and Montonye, LCDR James T., A Study of the Lights and Other Signals on Offshore Structures, August 1970 pp. B-1 - B-2
6. March, Alton K. "Frangibility of FAA Towers in Question," Aviation Week and Space Technology, August 21, 1978
7. PAR-56 Lampholder, Department of Transportation, Federal Aviation Administration, FAA-E-982e, July 24, 1978, page 3