

AD-A080 496

HUGHES AIRCRAFT CO CANOGA PARK CALIF MISSILE SYSTEMS--ETC F/G 1/3
DESIGN-FOR-REPAIR CONCEPT DEFINITION VOLUME III. FIELD EVALUATI--ETC(U)
AUG 79 F A GERKIN, J L GREEN, J M KING F33615-78-C-1461
MSG-92A5-VOL-3 AFAL-TR-79-1130-VOL-3 NL

UNCLASSIFIED

1 OF 3
AD
A080496



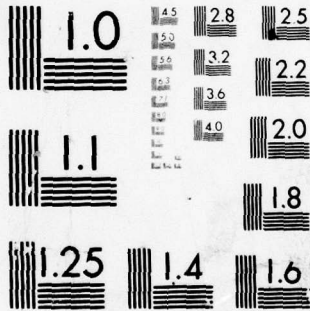

MICROCOPY RESOLUTION TEST CHART
NATIONAL BUREAU OF STANDARDS-1963-A

AFAL-TR-79-1130

② LEVEL III

SC

A080495

DA080496



DESIGN-FOR-REPAIR CONCEPT DEFINITION

Hughes Aircraft Company
Support Systems
Canoga Park, California 91304

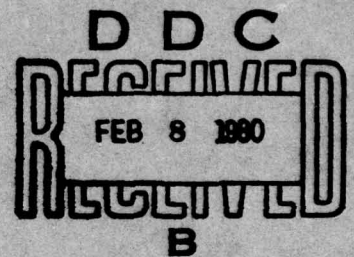

AUGUST 1979

VOLUME III: FIELD EVALUATION REPORTS, AFAL-TR-79-1130

Final Report for Period 15 August 1978 - 15 May 1979

DDC FILE COPY

Approved for Public Release; Distribution Unlimited

Air Force Avionics Laboratory
Air Force Wright Aeronautical Laboratories
Air Force Systems Command
Wright-Patterson Air Force Base, Ohio 45433

80 2 7 78

~~80 2 7 78~~

NOTICE

When Government drawings, specifications, or other data are used for any purpose other than in connection with a definitely related Government procurement operation, the United States Government thereby incurs no responsibility nor any obligation whatsoever; and the fact that the government may have formulated, furnished, or in any way supplied the said drawings, specifications, or other data, is not to be regarded by implication or otherwise as in any manner licensing the holder or any other person or corporation, or conveying any rights or permission to manufacture, use, or sell any patented invention that may in any way be related thereto.

This report has been reviewed by the Information Office (OI) and is releasable to the National Technical Information Service (NTIS). At NTIS, it will be available to the general public, including foreign nations.

This technical report has been reviewed and is approved for publication.

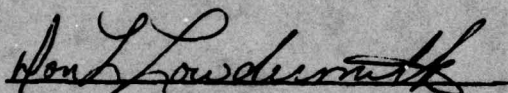
DON L. LOWDERMILK, 2Lt, USAF
Project Engineer

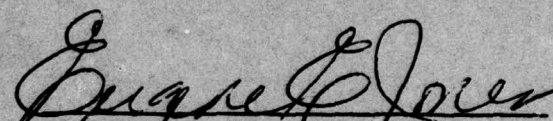
EUGENE S. JONES, Lt Col, USAF
Avionic Systems Engineering Branch
System Avionics Division

FOR THE COMMANDER

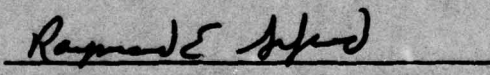
RAYMOND E. SIFERD, Colonel, USAF
Chief
System Avionics Division

"If your address has changed, if you wish to be removed from our mailing list, or if the addressee is no longer employed by your organization please notify AFAL/AAA, W-PAFB, OH 45433 to help us maintain a current mailing list".

Copies of this report should not be returned unless return is required by security considerations, contractual obligations, or notice on a specific document.

(18) REPORT DOCUMENTATION PAGE		READ INSTRUCTIONS BEFORE COMPLETING FORM	
1. REPORT NUMBER AFAL-TR-79-1130 - Vol-3		3. RECIPIENT'S CATALOG NUMBER	
4. TITLE (and Subtitle) Design-for-Repair Concept Definition Volume III, Field Evaluation Reports.		5. TYPE OF REPORT & PERIOD COVERED Final Report 15 August 1978 - 15 May 1979	
7. AUTHOR(s) F. A. Gerkin M. H. Cochran J. L. Green J. M. King		6. PERFORMING ORG. REPORT NUMBER MSG-9285 - Vol-3	
9. PERFORMING ORGANIZATION NAME AND ADDRESS Hughes Aircraft Company, Support Systems 8433 Fallbrook Canoga Park, CA 91304		8. CONTRACT OR GRANT NUMBER(s) F33615-78-C-1461	
11. CONTROLLING OFFICE NAME AND ADDRESS Air Force Avionics Laboratory (AFAL/AAA) Air Force Systems Command Wright-Patterson AFB, Ohio 45433		10. PROGRAM ELEMENT, PROJECT, TASK AREA & WORK UNIT NUMBERS 2003-09-11	
14. MONITORING AGENCY NAME & ADDRESS (if different from Controlling Office) 1-B043943L (12) 244		12. REPORT DATE August 1979	
		13. NUMBER OF PAGES 238	
		15. SECURITY CLASS. (of this report) Unclassified	
		15a. DECLASSIFICATION/DOWNGRADING SCHEDULE	
16. DISTRIBUTION STATEMENT (of this Report) Approved for public release; distribution unlimited.			
17. DISTRIBUTION STATEMENT (of the abstract entered in Block 20, if different from Report)			
18. SUPPLEMENTARY NOTES This technical report is also composed of the following: 1) Volume I, Technical Report 2) Volume II, Detailed Analyses			
19. KEY WORDS (Continue on reverse side if necessary and identify by block number) Design-for-Repair Maintainability Repairability Cost Effectiveness Availability Design Process Supportability			
20. ABSTRACT (Continue on reverse side if necessary and identify by block number) Current techniques used in the equipment design process have not improved avionics reparability to the level expected. This limitation on reparability results primarily from the maintenance concepts currently implemented and reparability techniques being "designed in" after the system design has been frozen. Subsequently, maintainability, reparability, availability, and supportability of AF equipment suffers during its inter-usable lifetime. The			

D D C
RECEIVED
FEB 8 1980
B

409721

15

BLOCK 20 Cont'd:

→ objective of this study was to identify and define Design-for-Repair Concepts which show the greatest potential for enhancing Air Force avionic maintenance. By identifying design and support problems associated with existing systems, design features required for implementation of an appropriate Design-for-Repair Concept or Concepts were then identified. This technical report includes the approach taken and the rationale on which Design-for-Repair Concepts were selected. The work conducted under this effort and the selected Design-for-Repair Concepts will formulate the baseline for the following phase of the effort, Design-for-Repair Methodology Guideline Development. This Phase II effort will provide the design engineer with methodologies and guidelines for designing repairability and maintainability into avionics equipment during the early design phases. The Air Force Program Monitor was Lt. Don L. Lowdermilk, System Evaluation Group, Avionic Systems Engineering Branch (AFAL/AAA-3).

PREFACE

The Design-For-Repair Concept Definition technical report is prepared in three separately bound books. Supportive analyses detail for the technical report are contained in the appendices.

Volume I - Technical Report

Volume II - Detailed Analyses

Volume III - Field Evaluation Reports

ACCESSION for		
NTIS	White Section	<input checked="" type="checkbox"/>
DDC	Buff Section	<input type="checkbox"/>
UNANNOUNCED		<input type="checkbox"/>
JUSTIFICATION _____		
BY _____		
DISTRIBUTION/AVAILABILITY CODES		
Dist.	AvAIL.	and/or SPECIAL
A		

TABLE OF CONTENTS

SECTION		PAGE
I	COMMUNICATIONS SUBSYSTEM	1
	AN/ARC-109 Radio	2
	AN/ARC-164 Radio	24
II	NAVIGATION SUBSYSTEM	42
	Mark V TACAN	43
	AN/ARN-118 TACAN	65
III	RECONNAISSANCE SUBSYSTEM	83
	KB-18A Strike Camera	84
	KS-97A Radar Scope Camera System	109
IV	WEAPONS DELIVERY SUBSYSTEM	131
	AN/AWG-20 Armament Control System	132
V	WEAPONS CONTROL SUBSYSTEM	154
	AN/APQ-130 Attack Radar	155
	AN/APG-63 Radar	180
	Target Identification System Electro-Optical (TISEO)	216

**DESIGN-FOR-REPAIR CONCEPT DEFINITION
FIELD EVALUATION REPORT**

DATE: 14 November 1978

BASE: Travis AFB, CA (10-12 October, 1978)		WEAPON SYSTEM: C-5A	
PERSONNEL CONTACTED: Col. J. Anderson (Asst Deputy Commander for Maintenance - 60th MAW) Lt. Col. J. Undlin Commander - 60th AMS) Maj. T. Stack (Maintenance Supervisor - 60th AMS) CMS Knobbe (Maintenance Superintendent - 60th AMS) Mr. A. Widner (Comm/Nav Branch Superintendent - 60th AMS) TSgt. Ackerman (NCOIC Comm Shop - 60th AMS) Mr. C. Arthur (Unit Chief - Warner Robins ALC Shop) Mr. C. Jackson (Line Chief - Warner Robins ALC Shop)			
SUBSYSTEM CATEGORY: UHF Communications		WORK UNIT CODE: 63A00	
SUBSYSTEM NOMENCLATURE: AN/ARC-109 Radio Set			
DESCRIPTION OF WEAPON SYSTEM MISSION: The C-5A provides airlift capability for moving fighting forces to any point on earth and is used to support air logistics needs of the DoD.			
DESCRIPTION OF SUBSYSTEM CAPABILITIES: The AN/ARC-109 radio provides 2-way amplitude modulated, double-sideband, full carrier radio telephone communications air-to-air and air-to-ground on any of 3500 channels spaced at 50 KHz intervals in the 225.59 to 339.95 MHz. band.			
NUMBER OF LRUs PER SUBSYSTEM: 3			
LRU NOMENCLATURE/PART NUMBER:		<ul style="list-style-type: none"> ● Receiver Transmitter - P/N 777-1575-001 ● Receiver Transmitter Control - P/N 777-1262-001 ● Shockmount Tray - P/N 522-4967-001 	
WEAPON SYSTEM FLIGHT HOURS PER MONTH: 75		SUBSYSTEM FLIGHT HOURS PER MONTH: 75	
SUBSYSTEM GROUND OPERATING TIME PER FLIGHT HOUR: 0.08		EVALUATOR: J. Green M. Cochran	

INSPECTION REQUIREMENTS (-6):

A 600 hour QC inspection of the system is performed to check cables, connections, etc. No power-on checks are required.

DESCRIPTION OF SUBSYSTEM DESIGN CHARACTERISTICS FOR MAINTENANCE:

- Electronics packaged in two LRUs.
- The R/T unit is modularized to simplify repair
- The R/T unit is equipped with an output meter
- The R/T unit is rack mounted and is easily replaced.

DESCRIPTION OF SPECIAL MAINTENANCE AIDS OR LOCAL MODIFICATIONS:

None

MAINTENANCE CONCEPT - DESIGN:

- The AN/ARC-109 system is designed for repair by LRU replacement.
- The R/T unit is modularized to allow module replacement in the intermediate shop and module repair in the depot shop.

OPERATIONAL ENVIRONMENT

The primary mission of the Military Airlift Command (MAC) is to provide rapid, responsive, reliable airlift of fighting forces to any point on earth where our national objectives are being challenged. As a secondary task, MAC is tasked to fulfill the global air logistics needs of the Department of Defense in sustaining its world-wide activities.

Operational concepts for tactical air forces requires a high degree of flexibility and mobility to attain proficiency in tactical operations. This capability must be established in the following areas:

- Quick-reactions deployment and employment anywhere in the world under any combat conditions
- Primary employment in limited war and special warfare operations
- Normal employment as a component of a joint force
- Operations of extended duration using a wide selection of weapons
- Economical operation under any combat situation
- Rapid transition from one type of warfare to another
- Establish force increments of varying size and type for specialized missions.

At a Bare Base deployment site the environment is identified by austere facilities, unfamiliar and severe climatic conditions, the increased tempo of operations, and personal emotional and physical stress. These bases range in capability from advanced terminals such as Orly in Paris on one extreme to narrow, weed-grown strips in Chad in Africa on the other. In addition, there are numerous other bases, where facilities for personnel support and general housekeeping are adequate, but the maintenance equipment is not equal to current advanced aircraft weapons systems.

MAINTENANCE ENVIRONMENT

The Military Airlift Wing (MAW) is organized and manned for organizational and field maintenance capability. Organizational level maintenance includes inspection, servicing, fault isolation, removal and replacement of components and system calibration. Servicing tasks encompass the loading and unloading of munitions. Field maintenance provides intermediate maintenance capability and is organized and capable of supporting the tactical units. This capability is the same at the deployed base as at the home base and includes repair and testing of engines; local manufacture of parts; testing, calibration and repair of aircraft and aerospace ground equipment, assemblies and components; and inspection and repair which is beyond the capability of organizational level maintenance. In addition, a complete precision measurement equipment laboratory is available to support maintenance functions.

DESIGN-FOR-REPAIR CONCEPT DEFINITION

CONTINUATION PAGE

DATE: 14 November 1978

By necessity, a large portion of required maintenance, e.g., unscheduled/scheduled, must be accomplished during the hours of darkness in preparation for the next mission (sortie). Maintenance capability must exist regardless of the hour of the day or weather conditions. The flightline maintenance environment is far from ideal. Flightline maintenance personnel are subjected to distractions of jet engines in operation, taxiing aircraft and jet blast. Use of handbooks and schematics normally associated with flightline maintenance is externally difficult for the reasons stated. Shop maintenance (intermediate maintenance) operations are more extensive than flightline maintenance functions. Even though work requirements may generate a need for around the clock operations and facilities are crowded, work is normally performed in some type of shelter, building, etc.

NATURAL ENVIRONMENT

Climatic conditions can range throughout the full spectrum of weather. During Bare Base operations, hostility requirements dictate that all operations will be conducted on a 24-hour day, 7-day week basis. The maintenance environment is subjected to extreme climatic variances due to rapid response deployment requirements. The amount of variance encountered relates directly to the degree of maintenance efficiency which may be expected and subsequently the effectiveness of the fighting unit.

Flightline maintenance activities expose both men and equipment to the mercy of the elements. Maintenance is performed around the clock and personnel are exposed to further distraction from high noise levels. Shop maintenance conditions are superior to those experienced on the flightline; however, crowded conditions exist generating a continuing programmed requirement for 24 hour shift work.

Climatic conditions of high humidity indirectly affect performance of electronic equipment to some degree. Extremes in temperature have a greater effect on maintenance personnel than on equipment. Extremes in temperature and humidity are directly related to the magnitude of the problems encountered and the solutions required to support immediate flight operations.

DESIGN-FOR-REPAIR CONCEPT DEFINITION

ACCESSIBILITY OF AVIONICS

DATE: 14 November 1978

GENERAL DESCRIPTION:

- Two AN/ARC-109 control units are mounted in the console at the pilots station. Access is gained by climbing two ladders (flight-line to cargo deck, cargo deck to flight deck) and going forward to pilots station
- Two AN/ARC-109 R/T units are rack-mounted in avionics compartments on the flight deck. Access is gained by climbing to the flight deck, going aft to the avionics

QUANTITATIVE VALUES:

- Control unit replacement can be accomplished by one man in 5 minutes
- R/T unit replacement can be accomplished by one man in 10 minutes.

DESCRIBE SUBSYSTEM REMOVAL:

- Control unit fasteners (6) are released by a quarter turn on each, then the unit is lifted from the console and a single quick-disconnect connector disconnects.
- R/T unit cables (3) are disconnected from front of unit and then two knurled knobs fasteners are backed off by hand to release unit from the shock mount.

DESIGN-FOR-REPAIR CONCEPT DEFINITION

AGE OF SYSTEM & TECHNOLOGY

DATE: 14 November 1978

GENERAL DESCRIPTION:

The AN/ARC-109 radio was installed in the C-5A aircraft in the early 70's. The radio design reflects technology in excess of 10 years old.

TYPE OF COMPONENTS USED:

- Discrete solid-state components
- Electro-mechanical channel switching

TYPE OF WIRING AND INTERFACE USED:

- Wiring - multistrand wires bound with sheaths or harnesses to form bundles. Air flex cable in place of coax cable is used between the R/T and antennas.
- Interface - quick disconnect multi-pin connectors on LRUs. Plug-in modules in the R/T unit.

SYSTEM DESIGN APPROACH (ANALOG, DIGITAL, SOFTWARE, ETC.):

Analog signal processing is used exclusively in the AN/ARC-109 radio set.

DESIGN-FOR-REPAIR CONCEPT DEFINITION

DEBRIEFING

DATE: 14 November 1978

DESCRIPTION OF THE DEBRIEFING FUNCTION:

The debriefing function operates independently from the radio shop. The UHF radio status is indicated by the aircrew through appropriate entries in the aircraft forms.

DESCRIBE THE DEBRIEFING PROCEDURE:

- Aircrew determines operational status of UHF radio
- Aircrew enters discrepancies in the aircraft forms
- Debriefing enters discrepancies, and job numbers plus other sortie data in debriefing forms
- Debriefing relays system status, by means of the debriefing forms, to maintenance control
- Maintenance control notifies the radio shop of UHF discrepancies

DESCRIBE DATA FLOW AND RECORDS:

- AFTO 781's - aircraft forms filled out by aircrew
- MAC 278 form - debriefing form filled out in debriefing
- AFTO 349's - maintenance data collection forms filled out by radio shop
- AFTO 350's - maintenance data collection forms attached to LRU's and SRU's requiring maintenance.

DESIGN-FOR-REPAIR CONCEPT DEFINITION

DEPOT SUPPORT

DATE: 14 November 1978

DESCRIPTION OF DEPOT SUPPORT SCOPE:

- LRU repair - R/T units and control units are repaired. Functional check (same as "I" level) is performed using AN/ARC-109 TS (locally manufactured) and AN/ARM-128 TS. Problem is fault-isolated to defective component which is replaced. Following repair, unit is retested.
- Module repair - R/T modules are repaired. Modules are checked in a mockup radio used in conjunction with AN/ARC-109 TS and AN/ARM-128 TS. Problem is fault-isolated to defective component which is replaced. Following module repair, the module is checked in a mock-up radio.

DEPOT SUPPORT EFFECTIVENESS:

Depot support of the AN/ARC-109 radio set is effective. No problems with lack of spares or delivery of defective units is being reported by the field shops.

COMMENTS:

- Control unit modules are hard-wired into unit. The control units are either returned to the depot for repair or repaired in the field.
- Depot repair of modules is normal, however, field repair of modules is authorized by the -6 as applied to the C-5A.
- AN/ARC-109 test set is locally manufactured to serve as inter-connection box in the hot mockup used for test purposes.

DESIGN-FOR-REPAIR CONCEPT DEFINITION

(PRE, IN, POST) -FLIGHT INSPECTION

DATE: 14 November 1978

DESCRIPTION OF THE INSPECTIONS:

- Maintenance does not perform inspections of the AN/ARC-109 radio set.
- Pre-flight inspections are performed by the aircrews as part of the aircraft pre-flight check lists.

FREQUENCY OF INSPECTIONS:

The AN/ARC-109 radio is checked by the aircrew each sortie.

PURPOSE OF INSPECTIONS:

The preflight check verifies the operational status of the two AN/ARC-109 radio sets prior to take-off.

COMMENTS:

Both UHF radio sets are checked during the aircraft preflight. The aircrew has the option of flying the sortie with one of the UHF radios not working.

DESIGN-FOR-REPAIR CONCEPT DEFINITION

LEVEL OF BASE REPAIR

DATE: 14 November 1978

DESCRIPTION OF ORGANIZATIONAL REPAIR:

1. UNSCHEDULED

Verify aircrew squawks and remove/replace defective LRUs.

2. SCHEDULED:

None

DESCRIPTION OF INTERMEDIATE REPAIR:

1. UNSCHEDULED

LRUs and SRUs are repaired where authorized by the -6. Normally, all LRUs and SRUs are repaired except for the frequency synthesizer and mechanical tuner modules. Repair is accomplished by replacing defective components.

2. SCHEDULED:

None

DESCRIPTION OF DEPOT REPAIR:

1. UNSCHEDULED:

LRU/SRU repair beyond the capability of the intermediate shops. Repair consists of replacing defective components

2. SCHEDULED:

None

DESIGN-FOR-REPAIR CONCEPT DEFINITION

MAINTAINABILITY CHARACTERISTICS OF EQUIPMENT DESIGN

DATE: 14 November 1978

GENERAL DESCRIPTION OF SUBSYSTEM FEATURES:

- The electronics is packaged in two LRUs
- Two AN/ARC-109 radio sets are installed in the C-5A so that comparison checks and substitution can be performed at the aircraft without spares.
- Modularized R/T unit contains 10 modules for fault-isolation by substitution and repair by replacement.
- Control unit contains electronics on circuit board hardwired into unit.

QUANTITATIVE VALUES:

- | | | |
|---|---|--|
| (1) MTBF - 121 Hours | (2) MTBM - 19.4 Hours @
Organizational Level | (3) MMH/FH - 0.3 Combined
Organizational & Inter-
mediate Levels |
| (4) MTTR - 2.3 Hours Organizational Level
7.1 Hours Intermediate Level | (5) MTBD - 64.3 Hours @ Organiza-
tional Level | |

All values based on AFM 66-1 data.

QUALITATIVE FEATURES:

- The control unit is panel mounted (5 minute replacement time)
- The R/T unit is rack mounted (10 minute replacement time)
- The R/T unit is modularized and can be easily fault-isolated by substitution of known good modules.
- The R/T unit requires approximately 3.5 hours to repair.

COMMENTS:

- Preset button on the control unit is a cause of false write-ups and should be covered by a door. Aircrews are changing the presets and then the presets are written-up on later sorties.
- Internally mounted fuses as presently uses in the control unit, should be replaced with an externally mounted fuse holder.

DESIGN-FOR-REPAIR CONCEPT DEFINITION

**MAINTENANCE DATA COLLECTION DOCUMENTATION
& FEEDBACK SYSTEM**

DATE: 14 November 1978

GENERAL DESCRIPTION:

The maintenance data collection system is in accordance with AFM 66-1 and MAC Regulation 66-18.

IMPLEMENTED METHODS:

Maintenance data is collected on the AFTO 349 form. Maintenance data manually logged on the 349's are keypunched and entered into the Air Force maintenance data system.

METHOD(S) EFFECTIVENESS:

The system is effective. Various reports containing management information are generated periodically to aid in identification of high failure radio sets. In addition, special reports can be generated as requested.

COMMENTS:

DESIGN-FOR-REPAIR CONCEPT DEFINITION

MAINTENANCE ORGANIZATION

DATE: 14 November 1978

GENERAL DESCRIPTION:

The 60th MAW maintenance function is organized in accordance with AFM 66-1.

MAINTENANCE ORGANIZATION FLOW CHART:

Maintenance of the C-5A avionics systems is accomplished by the 60th AMS. Flightline maintenance of the ARC-109 radio sets is accomplished by personnel dispatched from the 60th AMS radio shop. See attached charts.

DESIGN-FOR-REPAIR CONCEPT DEFINITION

CONTINUATION PAGE

DATE: 14 November 1978

MAINTENANCE ORGANIZATION FLOW CHART: (Continued)

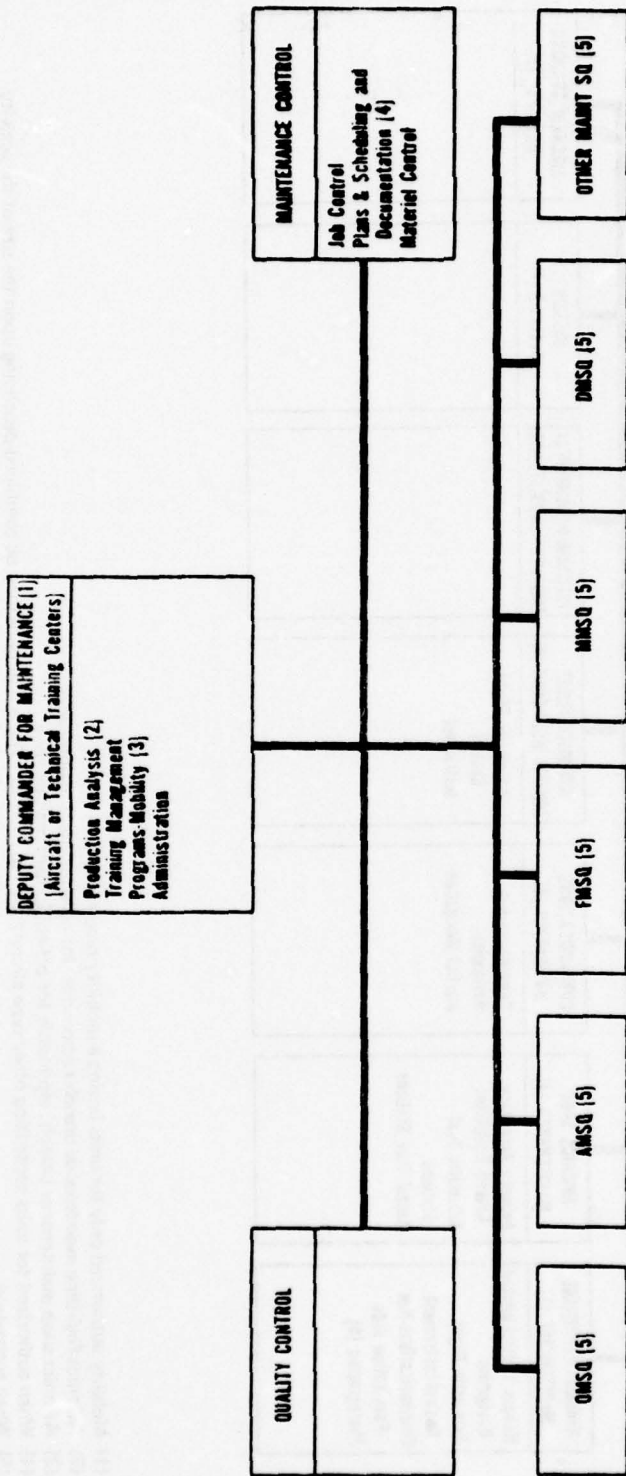

- (1) Functions organized as sections, branches, or divisions based on overall organizational structure and size of function.
- (2) Production analysis, training management, administration, and programs-mobility may each be organized directly under the deputy commander for maintenance, or they may be consolidated under one or more intermediate supervisor(s).
- (3) Mobility authorized only for units having mobility requirement. When the wing logistics plans function is aligned under the deputy commander for maintenance, this element will be known as the logistics plans, programs and mobility division, and will have total functional responsibility.
- (4) Includes the debriefing function.
- (5) When required to support assigned mission.

Figure 2-1. Deputy Commander for Maintenance Organization (Aircraft or Technical Training Centers).

DESIGN-FOR-REPAIR CONCEPT DEFINITION

CONTINUATION PAGE

DATE: 14 November 1978

MAINTENANCE ORGANIZATION FLOW CHART: (Continued)

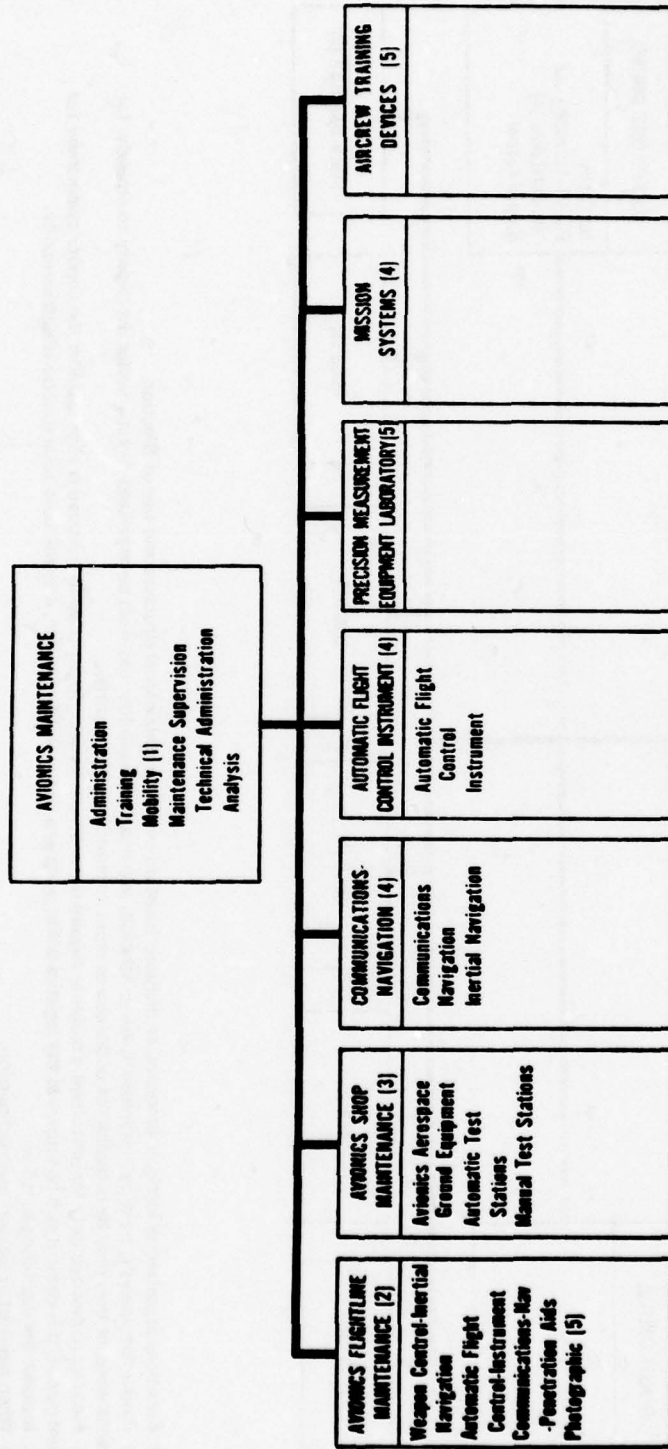

- (1) Mobility authorized only for units having a mobility requirement.
- (2) Avionics flightline maintenance branch responsible for on-equipment maintenance.
- (3) Avionics shop maintenance branch responsible for off-equipment maintenance.
- (4) When authorized for units supporting other type aircraft such as KC-135. These functions may be combined depending upon the size of the activity.
- (5) When authorized.

Figure 2-5. Integrated Avionics Systems Maintenance.

DESIGN-FOR-REPAIR CONCEPT DEFINITION

CONTINUATION PAGE

DATE: 14 November 1978

MAINTENANCE ORGANIZATION FLOW CHART: (Continued)

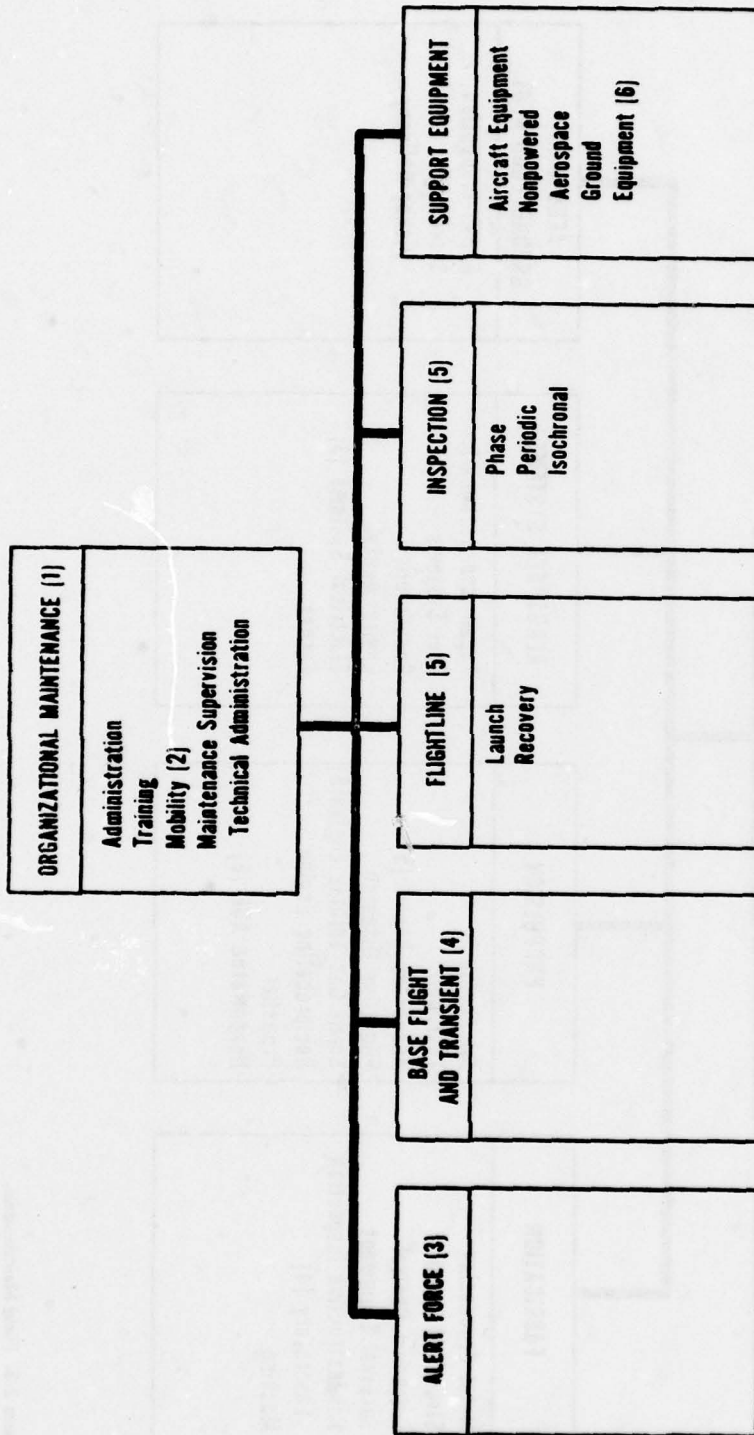

- (1) Organizational maintenance will be organized as a squadron, division branch, or section depending upon size of the activity for aircraft equipped units.
- (2) Mobility authorized only for units having a mobility requirement.
- (3) Alert force authorized only for units having an alert requirement.
- (4) Base flight function authorized only to units assigned base flight aircraft. When base flight aircraft is the mission of the unit, flightline and inspection functions may be utilized instead of base flight.
- (5) Inspection and flightline functions may be combined. A separate flightline or flightline/inspection function is permitted for each major aircraft type.
- (6) When authorized, nonpowered AGE may be realigned under the AGE branch of field maintenance.

Figure 2-2. Organizational Maintenance.

DESIGN-FOR-REPAIR CONCEPT DEFINITION

CONTINUATION PAGE

DATE: 14 November 1978

MAINTENANCE ORGANIZATION FLOW CHART: (Continued)

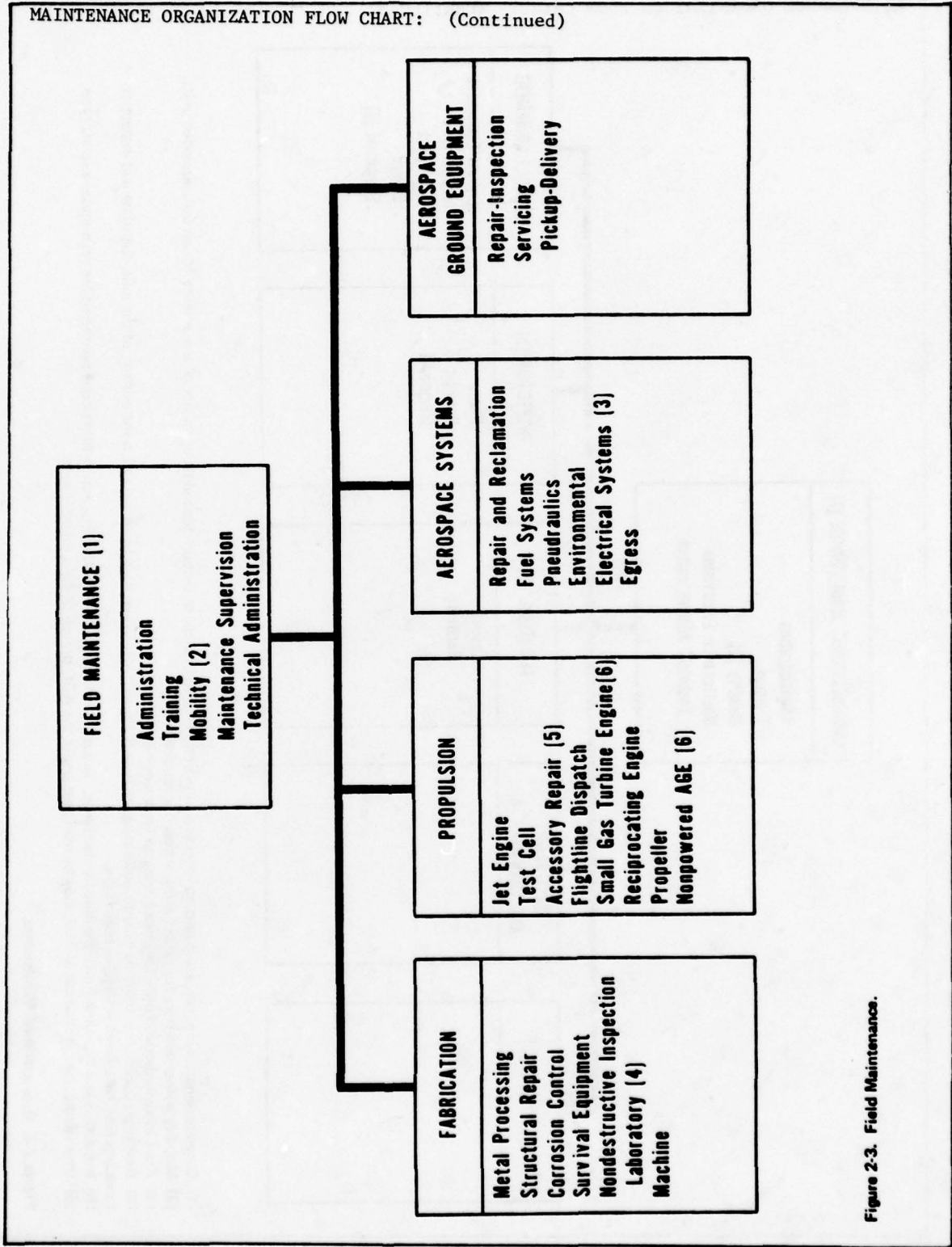

Figure 2-3. Field Maintenance.

DESIGN-FOR-REPAIR CONCEPT DEFINITION

ORGANIZATIONAL LEVEL AGE

DATE: 14 November 1978

DESCRIPTION OF AGE:

- Flightline equipment - No test equipment unique to the AN/ARC-109 radio set is used in the flightline. If required, however, the AN/ARM-113 radio test set from the intermediate shop is available for flight use.
- Shop equipment -
 - a. AN/ARC-109 test set and cabling
 - b. AN/ARM-113 Radio Test Set
 - c. AN/ARM-128 Radio Set Maintenance Kit

PURPOSE OF AGE:

- AN/ARC-109 test set - interconnection box to allow operation of a control unit and R/T unit as a hot mockup.
- AN/ARM-128 Radio Test Set - contains mounts, extenders, and special tools for maintenance of the R/T unit.
- AN/ARM-113 Radio Test Set - flightline test of the radio set

COMMENTS:

- AN/ARC-109 test set is locally manufactured. Different configurations were in use at the field and depot shops. Local manufacture of this test set is not considered appropriate by the using shops.
- AN/ARM-113 test set is a common radio test set which is not unique to the AN/ARC-109. Other equivalent test sets can also be utilized.

DESIGN-FOR-REPAIR CONCEPT DEFINITION

PREVENTIVE MAINTENANCE

DATE: 14 November 1978

GENERAL DESCRIPTION:

None.

PREVENTIVE MAINTENANCE REQUIREMENT SOURCE:

None.

COMMENTS:

Periodic checks of the radio sets is not required by the -6 and is not accomplished in support of the C-5A. Radio maintenance personnel are of the opinion that preventive maintenance is not necessary, but do recognize that a certain number of marginal radios and repeat write-ups are inevitable.

DESIGN-FOR-REPAIR CONCEPT DEFINITION

TECHNICAL ORDERS

DATE: 14 November 1978

DESCRIPTION OF TECH DATA REQUIREMENTS:

AN/ARC-109 (C-5A) - Organizational Maintenance. Radio, Communications and Navigation Systems, C-5A, T.O. 1C-5A-2-8-1, 13 October 1971, chge 29, 8 June 78.

Tech Man, IPB. Radio Set AN/ARC-109, T.O. 12R2-2ARC109-4, Collins Radio Group/Rockwell International.

AN/ARC-109 - Intermediate Maint. and Overhaul Insta, Radio Set AN/ARC-109, 1 October 1976, Chge 4, 26 May 78, T.O. 12R2-2ARC109-2

Tech Mab, IPB, AN/ARC-109 (C-5A), T.O. 12R2-2ARC109-4-1

DESCRIPTION OF TECH DATA FIELD DISCREPANCIES:

No significant discrepancies were discovered.

DESIGN-FOR-REPAIR CONCEPT DEFINITION

TRAINING & PERSONNEL SKILLS LEVEL

DATE: 14 November 1978

DESCRIPTION OF SKILLS REQUIREMENTS:

The 60th AMS radio shop is authorized the following personnel:

9 Levels - 1
7 Levels - 10
5 Levels - 35
3 Levels - 11
Civilians - 11

DESCRIPTION OF ASSIGNED SKILLS:

The 60th AMS radio shop presently has the following personnel assigned:

7 Levels - 8
5 Levels - 34
3 Levels - 7
Civilians - 18

GENERAL COMMENTS:

- Military personnel attrition - 30 to 40 percent
- Civilians provide stability in the shop maintenance organization due to their low turn-over rate.
- Flightline maintenance tasks assigned to least experienced shop personnel.

DESIGN-FOR-REPAIR CONCEPT DEFINITION

TROUBLESHOOTING METHODS

DATE: 14 November, 1978

DESCRIPTION OF ORGANIZATIONAL TROUBLESHOOTING METHODS:

Substitution techniques are used exclusively. Units are swapped between the two AN/ARC-109 radio sets in each C-5A.

DESCRIPTION OF INTERMEDIATE TROUBLESHOOTING METHODS:

- Substitution - the LRU is installed in the hot mock-up and SRUs are substituted from a known good mock-up unit.
- Signal tracing/probing - SRUs are fault-isolated using extenders, test instruments, and technical data.

DESCRIPTION OF DEPOT TROUBLESHOOTING METHODS:

Same as intermediate level techniques.

INSPECTION REQUIREMENTS (-6):

100 Hour Inspection:

- Visual checks of mounts, cables, etc., performed by Quality Control
- No power on checks are performed.

DESCRIPTION OF SUBSYSTEM DESIGN CHARACTERISTICS FOR MAINTENANCE:

One LRU, the R/T unit, contains approximately 98 percent of the electronics. The R/T unit is console mounted in the cockpit for ease of replacement. No BIT features are provided in the AN/ARC-164 subsystem. In addition, no unique support equipment is specified. The system must be tested with common VHF test equipment, fault-isolated by substitution, and repaired by LRU replacement.

DESCRIPTION OF SPECIAL MAINTENANCE AIDS OR LOCAL MODIFICATIONS:

A locally manufactured box (per Magnavox problem report) for reprogramming the R/T unit memory module was required at Edwards AFB. The guard frequency problem (from which the requirement resulted) was unique to a series of R/T units with a manufacturing defect and is not expected to be an operational problem.

MAINTENANCE CONCEPT - DESIGN:

The AN/ARC-164 subsystem is designed for fault-isolation by substitution and repair by LRU replacement. The R/T unit, which is the major LRU, is designed for repair by SRU replacement. The SRUs break down into circuit boards which are repairable by component replacement.

OPERATIONAL ENVIRONMENT

The tactical fighter will deploy using the bare base concept after introduction into Tactical Air Command (TAC) inventory.

Operational concepts for tactical air forces require a high degree of flexibility and mobility to attain proficiency in tactical operations. This capability must be established in the following areas:

- Quick-reactions deployment and employment anywhere in the world under any combat conditions
- Primary employment in limited war and special warfare operations
- Normal employment as a component of a joint force
- Operations of extended duration using a wide selection of weapons
- Economical operation under any combat situation

MAINTENANCE ENVIRONMENT

The tactical fighter squadron is organized and manned for organizational and field maintenance capability. Organizational level maintenance includes inspection, servicing, fault isolation, removal and replacement of components and system calibration. Servicing tasks encompass the loading and unloading of munitions. Field maintenance provides intermediate maintenance capability and is organized and capable of supporting the tactical squadrons. This capability is the same at the deployed base as at the home base and includes repair and testing of engines; local manufacture of parts; testing, calibration and repair of aircraft and aerospace ground equipment, assemblies and components; and inspection and repair which is beyond the capability of organizational level maintenance. In addition, a complete precision measurement equipment laboratory is available to support maintenance functions at home base and deployments to a Bare Base.

NATURAL ENVIRONMENT

Climatic conditions can range throughout the full spectrum of weather. During Bare Base operations, hostility requirements dictate that all operations will be conducted on a 24-hour day, 7-day week basis. The maintenance environment is subjected to extreme climatic variances due to rapid response deployment requirements. The amount of variance encountered relates directly to the degree of maintenance efficiency which may be expected and subsequently the effectiveness of the fighting unit.

Flightline maintenance activities expose both men and equipment to the mercy of the elements. Maintenance is performed around the clock and personnel are exposed to further distraction from high noise levels. Shop maintenance conditions are superior to those experienced on the flightline; however, crowded conditions exist generating a continuing programmed requirement for 24 hour shift work.

DESIGN-FOR-REPAIR CONCEPT DEFINITION

CONTINUATION PAGE

DATE: 18 October 1972

Operational Environment (Cont'd)

- Rapid transition from one type of warfare to another
- Establish force increments of varying size and type for specialized missions

At a Bare Base deployment site the environment is identified by austere facilities, unfamiliar and severe climatic conditions, the increased tempo of operations, and personal emotional and physical stress. These bases range in capability from advanced terminals such as Orly in Paris on one extreme to narrow, weed-grown strips in Chad in Africa on the other. In addition, there are numerous other bases, where facilities for personnel support and general housekeeping are adequate, but the maintenance equipment is not equal to current advanced aircraft weapons systems.

Maintenance Environment (Cont'd)

By necessity, a large portion of required maintenance, e.g., unscheduled/scheduled, must be accomplished during the hours of darkness in preparation for the next mission (sortie). Maintenance capability must exist regardless of the hour of the day or weather conditions. The flightline maintenance environment is far from ideal. Flightline maintenance personnel are subjected to distractions of jet engines in operation, taxiing aircraft and jet blast. Use of handbooks and schematics normally associated with flightline maintenance is externally difficult for the reasons stated. Shop maintenance (intermediate maintenance) operations are more extensive than flightline maintenance functions. Even though work requirements may generate a need for around the clock operations and facilities are crowded, work is normally performed in some type of shelter, building, etc.

Natural Environment (Cont'd)

Climatic conditions of high humidity indirectly affect performance of electronic equipment to some degree. Extreme temperature has a greater effect on maintenance personnel than on equipment. Extremes in temperature and humidity are directly related to the magnitude of the problems encountered and the solutions required to support immediate flight operations.

DESIGN-FOR-REPAIR CONCEPT DEFINITION

ACCESSIBILITY OF AVIONICS

DATE: 18 October 1978

GENERAL DESCRIPTION:

- 1) R/T unit located in left cockpit console
- 2) Frequency indicator located in instrument panel
- 3) Antenna Selector Relay located under access panel 2202 in electronics bay
- 4) Antenna Selector Panel located in cockpit console
- 5) Upper and lower antennas externally mounted
- 6) R/T unit consists of five SRUs
- 7) R/T SRUs consist of 15 subassemblies

QUANTITATIVE VALUES:

Twenty fasteners required for 2202 access door. Most problems are, however, solved by replacing R/T or indicator in cockpit.

DESCRIBE SUBSYSTEM REMOVAL:

The R/T unit can be removed by operating four front panel fasteners, lifting unit from console, and disconnecting from harness.

Indicator is removed from instrument panel by releasing two fasteners, pulling unit out from instrument panel, and disconnecting from harness.

The switching relay removal requires opening access door. Removing TACAN R/T, and then removing mounting bolts plus disconnecting COAXS.

DESIGN-FOR-REPAIR CONCEPT DEFINITION

AGE OF SYSTEM & TECHNOLOGY

DATE: 18 October 1978

GENERAL DESCRIPTION:

The AN/ARC-164 embodies technology of the mid 1970s. It represents a considerable advancement over previous VHF radios. The package is approximately one-third the volume of the AN/ARC-109. Reliability is increased considerably to around 1300 from 52 flight hours (AN/ARC-34) and 110 operating hours (AN/ARC-109).

TYPE OF COMPONENTS USED:

In general, discrete components are used, all solid state electronics, with limited or no use of ICs, LSIs, or hybrids.

TYPE OF WIRING AND INTERFACE USED:

Flat wiring harness connects rear connectors to boards and interconnects boards within the R/T unit.

SYSTEM DESIGN APPROACH (ANALOG, DIGITAL, SOFTWARE, ETC.):

Digital and analog electronics is used in the R/T unit. A mechanical rotary switch provides for channel (frequency) selection. LED display is provided on remote frequency indicator.

DESIGN-FOR-REPAIR CONCEPT DEFINITION

DEBRIEFING

DATE: 18 October 1978

DESCRIPTION OF THE DEBRIEFING FUNCTION:

The debriefing function operates independently of the "0" and "I" level Comm/Nav shops. System status is determined by aircrew at time of weapons system debriefing through appropriate entry in aircraft forms (781s).

DESCRIBE THE DEBRIEFING PROCEDURE:

- 1) Aircrews enter aircraft write-ups on 781 forms at debriefing.
- 2) Debriefers fill out AFFTC 300 form and assign job control numbers to write-ups.
- 3) AFFTC 300 form copy goes to "0" level shops for aircraft history.

DESCRIBE DATA FLOW AND RECORDS:

AFSC-TEST SQUADRON

AFTO 781 aircraft maintenance record
AFFTC 300 debriefing record
AFSC 258 (or 349) on aircraft maintenance
AFSC 258-9 (or 349) on aircraft plus off aircraft maintenance

TACTICAL UNIT

AFTO 349 on aircraft and shop maintenance (O/I/D)
AFTO 350 unit maintenance data (O/I/D)

DESIGN-FOR-REPAIR CONCEPT DEFINITION

DEPOT SUPPORT

DATE: 18 October 1978

DESCRIPTION OF DEPOT SUPPORT SCOPE:

Repair of LRUs, SRUs, and subassemblies:

- LRU repair - test with AN/ARM-173 and replace defective subassembly
- SRU repair - test with AN/ARM-173 (know good radio) and replace defective subassembly
- Subassembly repair - test with AN/ARM-175 and replace defective component

DEPOT SUPPORT EFFECTIVENESS:

- LRU repair \approx 3 hours
- Subassembly repair \approx 10 hours
- CNDs (LRUs) \approx 5 - 10% @ Warner Robins ALC

COMMENTS:

AN/ARM-173:

- Contains six power supplies (one could have been adequate)
- Provides no SRU test capability

F-16 AN/ARC-164s: This subsystem is still under warranty and being repaired by Magnavox. The AN/ARC-164 depot maintenance described above applies to radios of other aircraft.

DESIGN-FOR-REPAIR CONCEPT DEFINITION

(PRE, IN, POST) -FLIGHT INSPECTION

DATE: 18 October 1978

DESCRIPTION OF THE INSPECTIONS:

No flight inspections are performed by maintenance. Preflight checks are performed by aircrews. Preflight check consists of contacting the tower by using the VHF radio.

FREQUENCY OF INSPECTIONS:

Radio checks are accomplished on each sortie as part of normal utilization.

PURPOSE OF INSPECTIONS:

Preflight inspections provide a go-no-go check of radio system.

COMMENTS:

An extensive inspection is accomplished when the aircraft is received at Edwards. Radio checks are accomplished using SWR/RF power meter and include an operational check.

DESIGN-FOR-REPAIR CONCEPT DEFINITION

LEVEL OF BASE REPAIR

DATE: 18 October 1978

DESCRIPTION OF ORGANIZATIONAL REPAIR:

1. UNSCHEDULED:

- Remove and replace LRU
- No alignments required

2. SCHEDULED:

None

DESCRIPTION OF INTERMEDIATE REPAIR:

1. UNSCHEDULED:

Remove and replace module and accomplish alignments. Alignments are limited to eight adjustments which are accessible on front panel and bottom of unit. Module alignments are depot level tasks.

2. SCHEDULED:

None

DESCRIPTION OF DEPOT REPAIR:

1. UNSCHEDULED:

Repair LRU, SRU, or SRU subassembly. SRU or subassembly repair was the designed concept. LRU repair was not planned but is implemented. The radio is under a one year warranty by the contractor.

2. SCHEDULED:

None

DESIGN-FOR-REPAIR CONCEPT DEFINITION

MAINTAINABILITY CHARACTERISTICS OF EQUIPMENT DESIGN

DATE: 18 October 1978

GENERAL DESCRIPTION OF SUBSYSTEM FEATURES:

One LRU, the R/T unit, contains approximately 98 percent of the electronics. The R/T unit is console mounted in the cockpit and can be easily replaced. The R/T unit consists of five SRUs which are easily replaceable in the shop. The SRUs, with the exception of the switching unit, can be repaired by replacement of a circuit board. The SRUs are the: 1) switching unit, 2) synthesizer, 3) guard receiver, 4) main receiver, and 5) transmitter.

QUANTITATIVE VALUES:

(1) MTBF -

(2) MTBM -

(3) MMH/FH -

(4) MTTR -

These data values are not available from raw data and would be insignificant at this point in the acquisition phase.

QUALITATIVE FEATURES:

LRU and subsystem component replacement times are estimated to be as follows:

- R/T unit - 5 minutes
- Frequency channel indicator - 5 minutes
- Antenna switch (relay in lower right bay) - 30 minutes
- Antennas (upper or lower) - 30 minutes

COMMENTS:

The flex harness, which interconnects the five SRUs of the R/T unit, is prone to damage during disassembly/assembly of the R/T. Also, the mechanical switch in the switching unit (which is the highest failing item in the radio) is susceptible to damage by improper operation.

DESIGN-FOR-REPAIR CONCEPT DEFINITION

MAINTENANCE DATA COLLECTION DOCUMENTATION & FEEDBACK SYSTEM

DATE: 18 October 1978

GENERAL DESCRIPTION:

The maintenance data collection system is designed for the unique environment of the joint test force. Air Force Flight Test Center (AFFTC) forms and Air Force System Command (AFSC) forms are used to record maintenance data.

IMPLEMENTED METHODS:

- 1) The aircrew enters discrepancies on the AFTO 781 form .
- 2) Debriefing records discrepancies on the AFFTC 300 form.
- 3) Flightline maintenance (when no LRU is pulled) is recorded in the AFSC 258 form.
- 4) Flightline and shop maintenance is recorded in the AFSC 258-4 form when a unit is pulled.

METHOD(S) EFFECTIVENESS:

The form AFFTC 300 and form AFSC 258-4 provides a record of essential maintenance data. The form 300s provide an aircraft maintenance history while the form 258-4s provide a LRU maintenance history.

COMMENTS:

The form 258 appears to be redundant. Maintenance logged on the 258 can be logged on the 258-4. However, the stated purpose of the 258 is to save paper by providing only an original, rather than original plus three copies which the 258-4 provides.

DESIGN-FOR-REPAIR CONCEPT DEFINITION

MAINTENANCE ORGANIZATION

DATE: 18 October 1978

GENERAL DESCRIPTION:

F-16 flight testing is directly supported by a joint USAF - General Dynamics organization. USAF personnel from TAC are assigned to the 4486th which provides the "0" level support.

The 6515th provide "I" level support and is a host unit. The 6515th is an AFSC organization.

MAINTENANCE ORGANIZATION FLOW CHART:

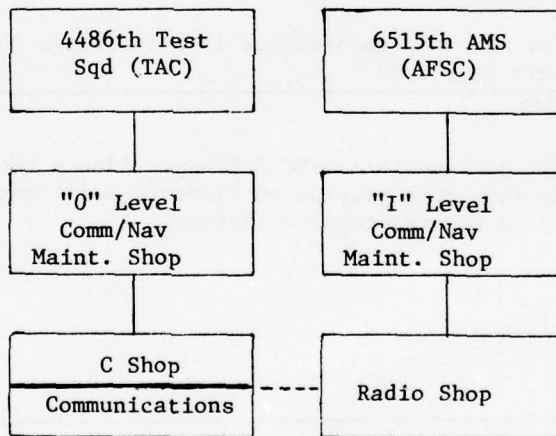

DESIGN-FOR-REPAIR CONCEPT DEFINITION

ORGANIZATIONAL LEVEL AGE

DATE: 18 October 1978

DESCRIPTION OF AGE:

No flightline AGE is required. Radio checks are normally accomplished by calling GCA or the control tower.

PURPOSE OF AGE:

Not applicable

COMMENTS:

None

DESIGN-FOR-REPAIR CONCEPT DEFINITION

PREVENTIVE MAINTENANCE

DATE: 18 October 1978

GENERAL DESCRIPTION:

- 100 hour periodic inspection by quality control to check: 1) wiring, 2) connectors and, 3) mounting.

A receiving inspection is accomplished on AN/ARD-164s received from supply for aircraft installation.

PREVENTIVE MAINTENANCE REQUIREMENT SOURCE:

T.O. IF-16A-6 requires 100 hour quality control inspection

COMMENTS:

No power-on radio checks are performed or required on a scheduled basis. Repeat write-ups and CNDs result from inadequate "O" level radio checks. A requirement for "O" level test equipment and a periodic check for power out, SWR, and receiver sensitivity would be supported by some "O" level Comm/Nav personnel. Others feel no "O" checks/equipment is required.

DESIGN-FOR-REPAIR CONCEPT DEFINITION

TECHNICAL ORDERS

DATE: 18 October 1978

DESCRIPTION OF TECH DATA REQUIREMENTS:

IF-16A-2-23-GS-00-1	Communication General System Description
IF-16A-2-23-FI-00-1	Fault Isolation Communication System
IF-16A-2-23-JG-20-1	Job Guide Communications System
IF-16A-6	Scheduled Inspection and Maintenance Requirements
IF-16A-06	Work Unit Code Manual
TO 12R2-2ARC164-2	Maintenance Instruction-Intermediate Radio Set AN/ARC-164(V)
TO 12R2-2ARC164-4	Illustrated Parts Breakdown
TO 12R2-2ARC164-3	Maintenance Instruction-Depot Radio Set AN/ARC-164(V)

DESCRIPTION OF TECH DATA FIELD DISCREPANCIES:

All "0" level T.O.s are for the full scale development phase of the program. Many suggested revisions have been submitted and no major concerns are presently voiced.

"I" level manuals are adequate.

DESIGN-FOR-REPAIR CONCEPT DEFINITION

TRAINING & PERSONNEL SKILLS LEVEL

DATE: 18 October 1978

DESCRIPTION OF SKILLS REQUIREMENTS:

Training and personnel skills level observations represented test personnel at Edwards AFB and does not reflect a Tactical unit.

DESCRIPTION OF ASSIGNED SKILLS:

Not applicable

GENERAL COMMENTS:

None

DESIGN-FOR-REPAIR CONCEPT DEFINITION

TROUBLESHOOTING METHODS

DATE: 18 October 1978

DESCRIPTION OF ORGANIZATIONAL TROUBLESHOOTING METHODS:

- 1) Substitution of units (LRUs)
- 2) Wiring checks with PSM-6
- 3) Power/SWR checks with watt meter

DESCRIPTION OF INTERMEDIATE TROUBLESHOOTING METHODS:

- 1) LRUs are functionally checked using AN/ARM-173
- 2) Technical order fault isolation procedures are used and/or the substitution of a like item is used.

DESCRIPTION OF DEPOT TROUBLESHOOTING METHODS:

- 1) Test LRU in AN/ARM-173 and find SRU subassembly by substitution
- 2) Test SRU subassembly in AN/ARM-175 and find bad component by signal tracing techniques (manual probing)

(1) Description of work (20%)

(2) Working hours with 100%

(3) Working hours with 50%

SECTION II NAVIGATION SUBSYSTEM

(1) Description of work (20%)

(2) Working hours with 100%

(3) Working hours with 50%

(1) Description of work (20%)

(2) Working hours with 100%

(3) Working hours with 50%

**DESIGN-FOR-REPAIR CONCEPT DEFINITION
FIELD EVALUATION REPORT**

DATE: 15 November 1978

BASE: Travis, AFB, CA (6 November 1978)		WEAPON SYSTEM: C-5A	
PERSONNEL CONTACTED: Col. J. Anderson (Asst. Deputy Commander for Maintenance) Lt. Col. J Undlin (Commander-60th AMS) Major. T. Stack (Maintenance Supervisor - 60th AMS) CMS Knobbe (Maintenance Superintendent - 60th AMS) Mr. A Widner (Comm/NAS Branch Superintendent-60th AMS) TSGT. Briggs (NCOIC NAV. Shop - 60th AMS) Mr. D. Cook (Unit Chief - Warner Robins ALC Shop) Mr. J. Cooper (Line Chief - Warner Robins ALC Shop)			
SUBSYSTEM CATEGORY: Navigation		WORK UNIT CODE: 71L00	
SUBSYSTEM NOMENCLATURE: MARK V TACAN Navigational Set			
DESCRIPTION OF WEAPON SYSTEM MISSION: The C-5A provides airlift capability for moving fighting forces to any point on earth and is used to support air logistics needs of the Department of Defense			
DESCRIPTION OF SUBSYSTEM CAPABILITIES: The TACAN set is a 126 channel UHF receiver-transmitter with decoding and data computation capabilities for determining bearing and slant range to a beacon. The TACAN set has both air-to-ground and air-to-air capability.			
NUMBER OF LRUs PER SUBSYSTEM: 2			
LRU NOMENCLATURE/PART NUMBER: Receiver-Transmitter, P/N-801000089-1 Control Panel, P/N 801000090			
WEAPON SYSTEM FLIGHT HOURS PER MONTH: 75		SUBSYSTEM FLIGHT HOURS PER MONTH: 75	
SUBSYSTEM GROUND OPERATING TIME PER FLIGHT HOUR: 0.08		EVALUATOR: J. Green M. Cochran	

INSPECTION REQUIREMENTS (-6):

A 600 hour QC inspection of the system is performed to check cables, connections, etc. No power-on checks are required.

DESCRIPTION OF SUBSYSTEM DESIGN CHARACTERISTICS FOR MAINTENANCE:

- o Electronics packaged in two LRUs
- o BIT circuitry provides go/no-go status in cockpit
- o Modularized R/T unit to simplify repair

DESCRIPTION OF SPECIAL MAINTENANCE AIDS OR LOCAL MODIFICATIONS:

None

MAINTENANCE CONCEPT - DESIGN:

- o System repair by LRU replacement
- o System fault-isolation by substitution
- o LRU repair by SRU replacement
- o SRU repair by circuit board replacement
- o Discardable circuit boards

OPERATIONAL ENVIRONMENT

The primary mission of the Military Airlift Command (MAC) is to provide rapid, responsive, reliable airlift of fighting forces to any point on earth where our national objectives are being challenged. As a secondary task, MAC is tasked to fulfill the global air logistics needs of the Department of Defense in sustaining its world-wide activities.

Operational concepts for tactical air forces requires a high degree of flexibility and mobility to attain proficiency in tactical operations. This capability must be established in the following areas:

- o Quick-reactions deployment and employment anywhere in the world under any combat conditions
- o Primary employment in limited war and special warfare operations
- o Normal employment as a component of a joint force
- o Operations of extended duration using a wide selection of weapons
- o Economical operation under any combat situation

(See continuation Sheet)

MAINTENANCE ENVIRONMENT

The Military Airlift Wing (MAW) is organized and manned for organizational and field maintenance capability. Organizational level maintenance includes inspection, servicing, fault isolation, removal and replacement of components and system calibration. Servicing tasks encompass the loading and unloading of munitions. Field maintenance provides intermediate maintenance capability and is organized and capable of supporting the tactical units. This capability is the same at the deployed base as at the home base and includes repair and testing of engines; local manufacture of parts; testing, calibration and repair of aircraft and aerospace ground equipment, assemblies and components; and inspection and repair which is beyond the capability of organizational level maintenance. In addition, a complete precision measurement equipment laboratory is available to support maintenance functions.

By necessity, a large portion of required maintenance, e.g., unscheduled/scheduled, must be accomplished during the hours of darkness in preparation for the next mission (sortie). Maintenance capability must exist regardless of the hour of the day or weather conditions. The flightline maintenance environment is far from ideal. Flightline maintenance personnel are subjected to distractions of jet

(See Continuation Sheet)

NATURAL ENVIRONMENT

Climatic conditions can range throughout the full spectrum of weather. During Bare Base operations, hostility requirements dictate that all operations will be conducted on a 24-hour day, 7-day week basis. The maintenance environment is subjected to extreme climatic variances due to rapid response deployment requirements. The amount of variance encountered relates directly to the degree of maintenance efficiency which may be expected and subsequently the effectiveness of the fighting unit.

Flight-line maintenance activities expose both men and equipment to the mercy of the elements. Maintenance is performed around the clock and personnel are exposed to further distraction from high noise levels. Shop maintenance conditions are superior to those experienced on the flightline; however, crowded conditions exists generating a continuing programmed requirement for 24 hour shift work.

(See Continuation Sheet)

DESIGN-FOR-REPAIR CONCEPT DEFINITION

CONTINUATION PAGE

DATE: 15 November 1978

OPERATIONAL ENVIRONMENT

- o Rapid transition from one type of warfare to another
- o Establish force increments of varying size and type for specialized missions

At a Bare Base deployment site the environment is identified by austere facilities, unfamiliar and severe climatic conditions, the increased tempo of operations, and personal emotional and physical stress. These bases range in capability from advanced terminals such as Orly in Paris on one extreme to narrow, weed-grown strips in Chad in Africa on the other. In addition, there are numerous other bases, where facilities for personnel support and general housekeeping are adequate, but the maintenance equipment is not equal to current advanced aircraft weapons systems.

MAINTENANCE ENVIRONMENT

engines in operation, taxiing aircraft and jet blast. Use of handbooks and schematics normally associated with flightline maintenance is externally difficult for the reasons stated. Shop maintenance (intermediate maintenance) operations are more extensive than flightline maintenance functions. Even though work requirements may generate a need for around the clock operations and facilities are crowded, work is normally performed in some type of shelter, building, etc.

NATURAL ENVIRONMENT

Climatic conditions of high humidity indirectly affect performance of electronic equipment to some degree. Extreme temperature has a greater effect on maintenance personnel than on equipment. Extremes in temperature and humidity are directly related to the magnitude of the problems encountered and the solutions required to support immediate flight operations.

DESIGN-FOR-REPAIR CONCEPT DEFINITION

ACCESSIBILITY OF AVIONICS

DATE: 15 November 1978

GENERAL DESCRIPTION:

- o Two TACAN control units are mounted in the console at the pilot station. Access is gained by climbing ladders from flightline to cargo deck to flight deck and going forward to pilot station.
- o Two TACAN R/T units are rack-mounted in avionics compartments on the flight deck. Access is gained by climbing to flight deck, going aft to avionics compartments, and opening avionics compartment door.

QUANTITATIVE VALUES:

- o Control unit replacement can be accomplished by one man in approximately 5 minutes.
- o R/T unit replacement can be accomplished by one man in approximately 10 minutes.

DESCRIBE SUBSYSTEM REMOVAL:

- o Control unit fasteners (4) are released by a quarter turn on each and then the unit is lifted out of the console and one quick-disconnect connector disconnected.
- o R/T unit coax connectors (2) are disconnected from front panel and then two knurled knob fasteners backed off by hand to release unit from rack.

DESIGN-FOR-REPAIR CONCEPT DEFINITION

AGE OF SYSTEM & TECHNOLOGY

DATE: 15 November 1978

GENERAL DESCRIPTION:

The Mark V TACAN was installed in the C-5A aircraft in the early 70s. The Hoffman design reflects technology in excess of 10 years old.

TYPE OF COMPONENTS USED:

- o Discrete solid-state components

TYPE OF WIRING AND INTERFACE USED:

- o Wiring - multistrand wires bound with harnesses/sheaths to form cables.
- o Interface - a quick disconnect multipin connector is used on control box. A rack mounted connector interfaces with the R/T unit along with coax connectors. Plug-in modules are used in the R/T unit.

SYSTEM DESIGN APPROACH (ANALOG, DIGITAL, SOFTWARE, ETC.):

Analog and digital signal processing techniques are used in the Mark V TACAN set.

DESIGN-FOR-REPAIR CONCEPT DEFINITION

DEBRIEFING

DATE: 15 November 1978

DESCRIPTION OF THE DEBRIEFING FUNCTION:

The debriefing function operates independently from the Navigation Shop. The C-5A TACAN status is indicated by the aircrew through appropriate entries in the aircraft forms during debriefing.

DESCRIBE THE DEBRIEFING PROCEDURE:

- o Aircrew determines operational status of the TACAN set.
- o Aircrew enters discrepancies in the aircraft forms
- o Debriefers enters discrepancies and job numbers in debriefing forms.
- o Debriefing relays TACAN status, by means of the debriefing forms, to maintenance control.
- o Maintenance control notifies the Navigation Shop of TACAN discrepancies.

DESCRIBE DATA FLOW AND RECORDS:

- o AFTO 781s - aircraft forms filled out by aircrew
- o MAC 278s - debriefing form filled out by debriefer
- o AFTO 349s - maintenance data collection forms filled out by Navigation Shop
- o AFTO 350s - maintenance data collection forms attached to LRUs/SRUs requiring maintenance

DESIGN-FOR-REPAIR CONCEPT DEFINITION

DEPOT SUPPORT

DATE: 15 November 1978

DESCRIPTION OF DEPOT SUPPORT SCOPE:

LRU Repair - All control, units, some R/T units and all SRUs from the R/T units are sent to the depot for repair. Depot support is accomplished at Warner Robins ALC.

DEPOT SUPPORT EFFECTIVENESS:

Depot support of the MARK V TACAN appears to be effective. No complaints regarding lack of spares or delivery of defective LRUs/SRUs were reported.

COMMENTS:

SRU repair is accomplished at the depot because of extensive test equipment requirements. Four module testers are required. Each module tester serves as an interconnection box with power supplies, etc. for providing stimuli and monitoring to the UUT.

DESIGN-FOR-REPAIR CONCEPT DEFINITION

(PRE, IN, POST) -FLIGHT INSPECTION

DATE: 13 November 1978

DESCRIPTION OF THE INSPECTIONS:

- o Maintenance does not perform pre, in, post-flight inspections of the C-5A TACAN
- o Pre-flight inspections are accomplished by the aircrew during aircraft pre-flight

FREQUENCY OF INSPECTIONS:

Inspections of the C-5A TACAN are accomplished each sortie

PURPOSE OF INSPECTIONS:

The pre-flight TACAN check verifies the operational status of the two TACAN sets prior to take-off.

COMMENTS:

Both TACAN sets are checked during the aircraft pre-flight. The aircrew accomplishes the check by selecting the local TACAN station and verifying range and bearing readings from sets.

DESIGN-FOR-REPAIR CONCEPT DEFINITION

LEVEL OF BASE REPAIR

DATE: 15 November 1978

DESCRIPTION OF ORGANIZATIONAL REPAIR:

1. UNSCHEDULED:

Verify aircrew squawks and remove/replace defective LRUs.

2. SCHEDULED:

None

DESCRIPTION OF INTERMEDIATE REPAIR:

1. UNSCHEDULED:

Functional test; fault isolation to the SRU, and replacement of the SRU.

2. SCHEDULED:

None

DESCRIPTION OF DEPOT REPAIR:

1. UNSCHEDULED:

Functional test, fault isolation, and repair of LRUs and SRUs.

2. SCHEDULED:

None

DESIGN-FOR-REPAIR CONCEPT DEFINITION

MAINTAINABILITY CHARACTERISTICS OF EQUIPMENT DESIGN

DATE: 15 November 1978

GENERAL DESCRIPTION OF SUBSYSTEM FEATURES:

- o Electronics packaged in two LRUs
- o Two complete TACAN sets installed in C-5A allow cross-checking and swapping of units.
- o Modularized R/T unit consists of plug-in SRUs. TACAN functions are logically grouped in the SRUs to simplify fault isolation by substitution.
- o Modularized SRUs contain as many as 15 plug-in boards to simplify repair.

QUANTITATIVE VALUES:

- | | | |
|---|---|---|
| (1) MTBF - 134.6 Hours | (2) MTBM - 43.4 Hours @
Organizational Level | (3) MMH/FH - 0.26 Combined
Organizational & Inter-
mediate Levels |
| (4) MTTR - 4.2 Hours @ Organizational Level
6.0 Hours @ Intermediate Level | (5) MTBD - 94.8 Hours @ Organi-
zational Level | |

All values are from AFM 65-1 data.

QUALITATIVE FEATURES:

- o The control units are console mounted and can be easily swapped for fault isolation by substitution (10 min. estimate)
- o The R/T units are rack mounted and can be easily swapped for fault isolation by substitution (20 min. estimate)

COMMENTS:

- o Two-level modularization has been pursued extensively. Intermediate and depot maintenance personnel commented on the ease of fault isolation and repair.
- o Redundant TACAN installation in the C-5A simplifies fault isolation by substitution, and in conjunction with BIT plus use of local station, reduces dependency on flightline test sets.

DESIGN-FOR-REPAIR CONCEPT DEFINITION

**MAINTENANCE DATA COLLECTION DOCUMENTATION
& FEEDBACK SYSTEM**

DATE: 15 November 1978

GENERAL DESCRIPTION:

The maintenance data collection system is in accordance with AFM 66-1 and MAC Regulation 66-18

IMPLEMENTED METHODS:

Maintenance data is collected on the AFTO 349s. Data on the 349s is keypunched and entered into the Air Force maintenance data system.

METHOD(S) EFFECTIVENESS:

The system is effective. Various reports containing management information are generated periodically (one purpose is identification of high failure TACAN sets). In addition, special reports can be obtained as required.

COMMENTS:

DESIGN-FOR-REPAIR CONCEPT DEFINITION

MAINTENANCE ORGANIZATION

DATE: 15 November 1978

GENERAL DESCRIPTION:

The 60th MAW maintenance function is organized in accordance with AFM 66-1.

MAINTENANCE ORGANIZATION FLOW CHART:

Maintenance of the C-5A Avionics Systems is accomplished by the 60th AMS. Flightline maintenance of the C-5A TACAN is accomplished by personnel dispatched from the 60th AMS Navigation Shop. See attached maintenance organization charts.

DESIGN-FOR-REPAIR CONCEPT DEFINITION

CONTINUATION PAGE

DATE: 15 November 1978

(Maintenance Org. Flow Chart)

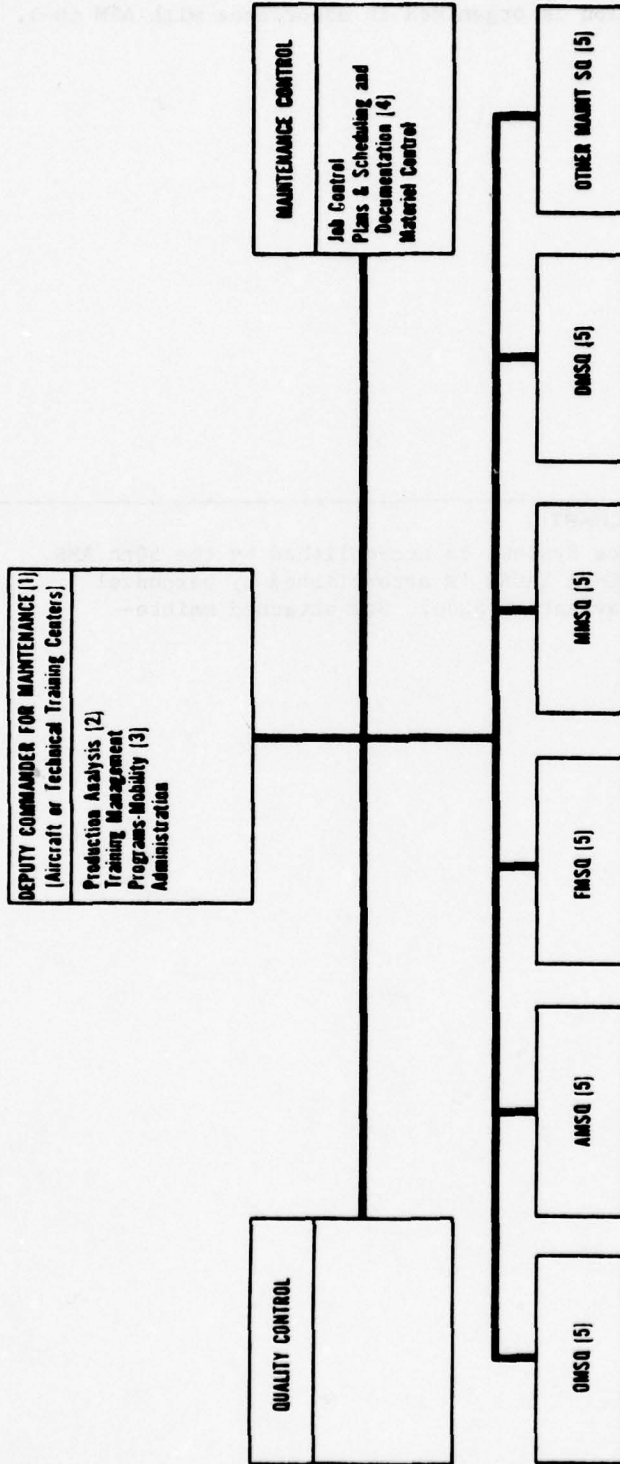

- (1) Functions organized as sections, branches, or divisions based on overall organizational structure and size of function.
- (2) Production analysis, training management, administration, and programs-mobility may each be organized directly under the deputy commander for maintenance, or they may be consolidated under one or more intermediate supervisor(s).
- (3) Mobility authorized only for units having mobility requirement. When the wing logistics plans function is aligned under the deputy commander for maintenance, this element will be known as the logistics plans, programs and mobility division, and will have total functional responsibility.
- (4) Includes the debriefing function.
- (5) When required to support assigned mission.

Figure 2-1. Deputy Commander for Maintenance Organization (Aircraft or Technical Training Centers).

DESIGN-FOR-REPAIR CONCEPT DEFINITION

CONTINUATION PAGE

DATE: 15 November 1978

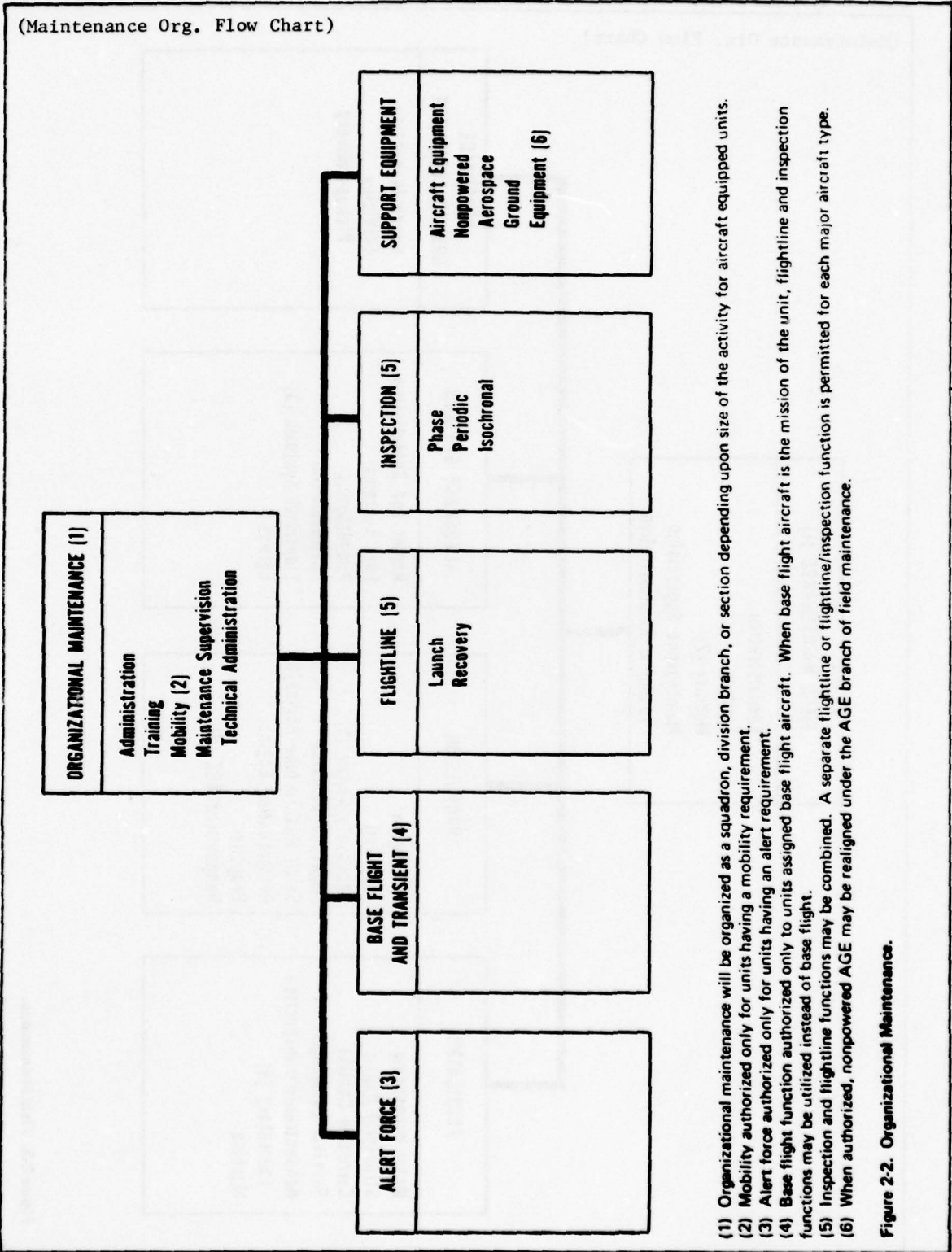

DESIGN-FOR-REPAIR CONCEPT DEFINITION

CONTINUATION PAGE

DATE: 15 November 1978

(Maintenance Org. Flow Chart)

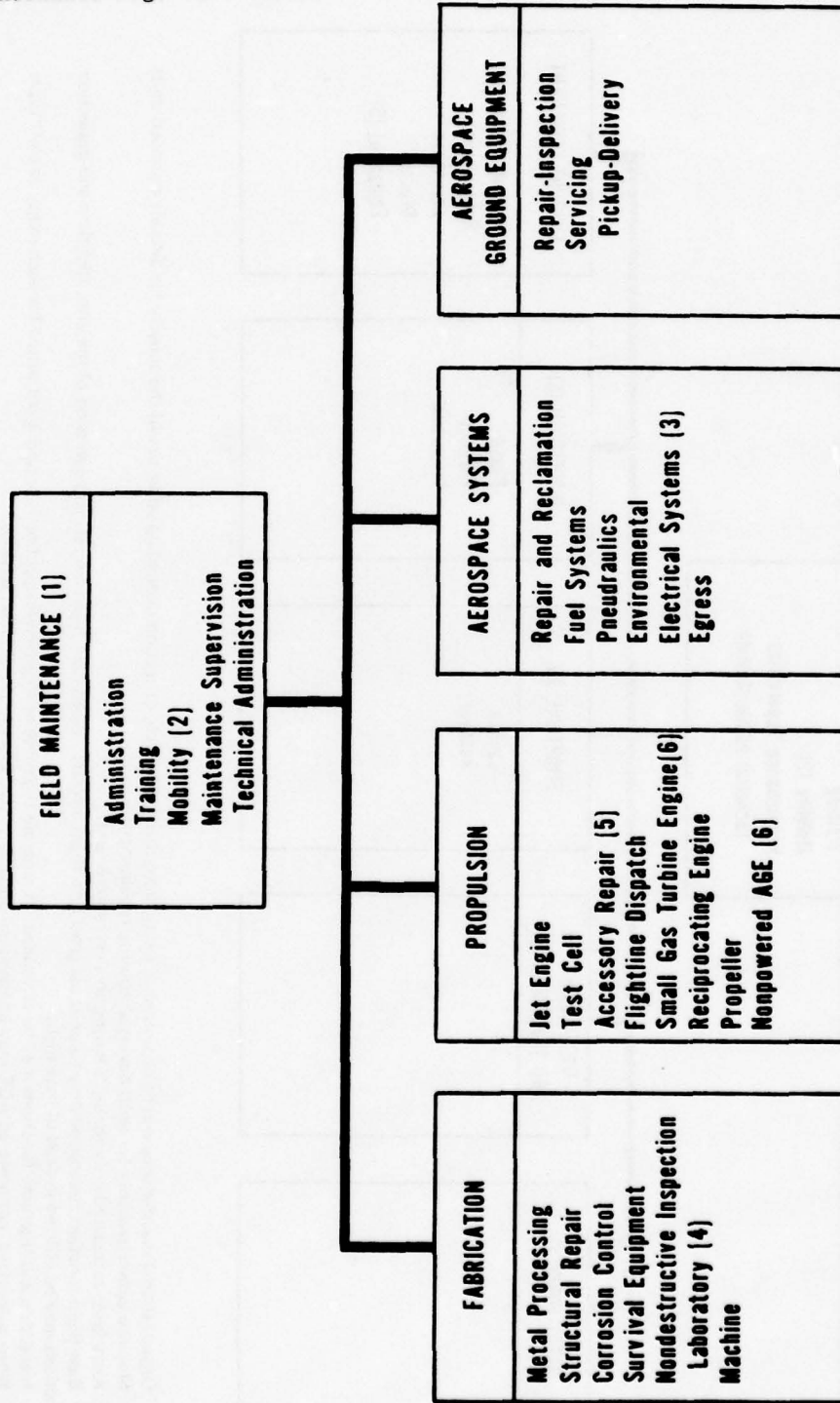

Figure 2-3. Field Maintenance.

DESIGN-FOR-REPAIR CONCEPT DEFINITION

CONTINUATION PAGE

DATE: 15 November 1978

(Maintenance Org. Flow Chart)

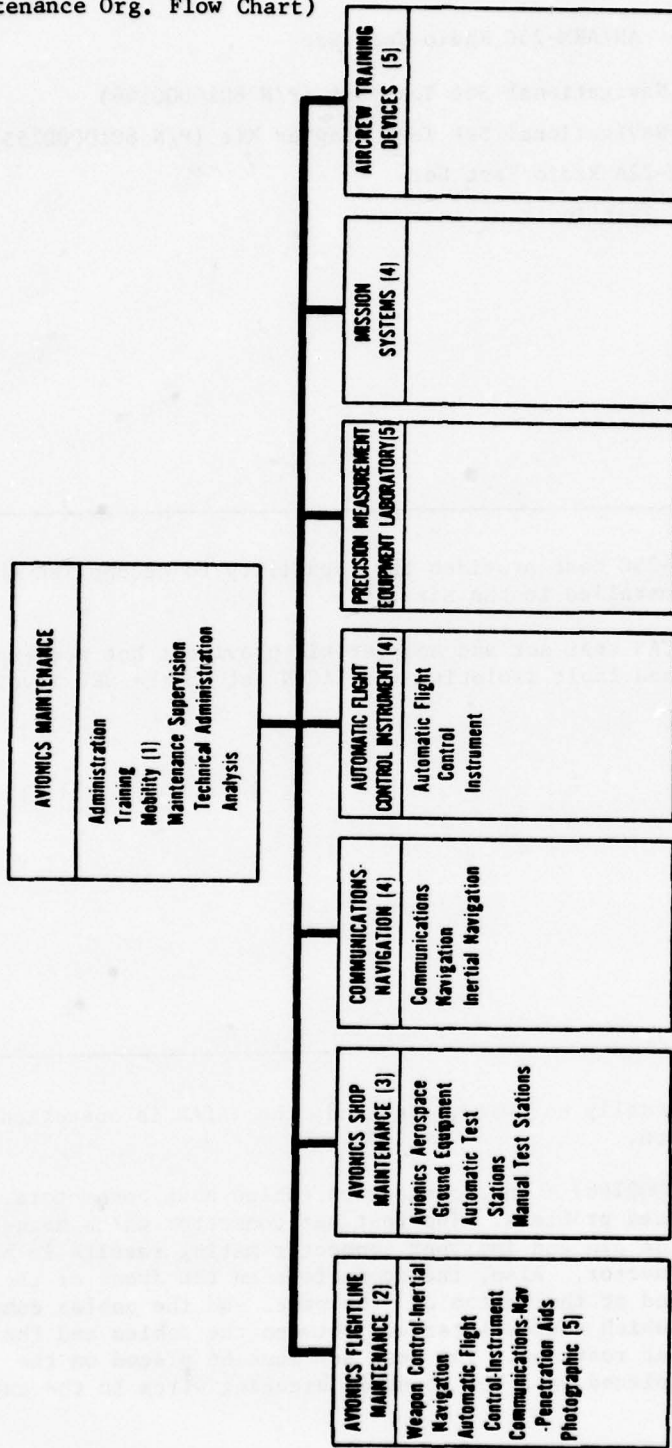

- (1) Mobility authorized only for units having a mobility requirement.
- (2) Avionics flightline maintenance branch responsible for on-equipment maintenance.
- (3) Avionics shop maintenance branch responsible for off-equipment maintenance.
- (4) When authorized for units supporting other type aircraft such as KC-135. These functions may be combined depending upon the size of the activity.
- (5) When authorized.

Figure 2-5. Integrated Avionics Systems Maintenance.

DESIGN-FOR-REPAIR CONCEPT DEFINITION

ORGANIZATIONAL LEVEL AGE

DATE: 15 November 1978

DESCRIPTION OF AGE:

- o Flightline Equipment - AN/ARM-25C Radio Test Set
- o Shop Equipment - TACAN Navigational Set Test Set (P/N 8010000196)
TACAN Navigational Set Test Adapter Kit (P/N 8010000153)
AN/ARM-22A Radio Test Set
Common Test Instruments

PURPOSE OF AGE:

- o Flightline - the AN/ARM-25C test provides the capability to accomplish checks of the TACAN Set when installed in the aircraft.
- o Shop Equipment - the TACAN test set and adapter kit provide a hot mock-up capability for testing and fault isolating the TACAN set to the SRU level.

COMMENTS:

- o Flightline Test Set - Normally not used. Instead, the TACAN is operationally checked on a local station.
- o TACAN Test Set (P/N 8010000196) - interconnection cables have connectors on both ends which have caused problems. The test set connector which mates with the R/T unit lacks a guide pin and improper connector mating results in bent pins on the test set connector. Also, the connectors on the front of the test set panel are located at the bottom of the panel and the cables come off at a 90° angle down which causes interface between the cables and the surface which the test set rests on. The test set must be placed on the edge of a work bench or placed on a box to avoid breaking wires in the cables.

DESIGN-FOR-REPAIR CONCEPT DEFINITION

PREVENTIVE MAINTENANCE

DATE: 15 November 1978

GENERAL DESCRIPTION:

None

PREVENTIVE MAINTENANCE REQUIREMENT SOURCE:

None

COMMENTS:

Periodic checks of the C-5A TACAN sets are not accomplished by the Navigation Shop and are not required by the -6. TACAN maintenance personnel recognize that some marginal TACAN sets and repeat writes are inevitable but, based on extensive experience with this equipment, do not consider this a significant problem.

DESIGN-FOR-REPAIR CONCEPT DEFINITION

TECHNICAL ORDERS

DATE: 15 November 1978

DESCRIPTION OF TECH DATA REQUIREMENTS:

Flightline Maintenance - T.O. 1C-5A-2-8-1

Field Maintenance - T.O. 12R5-4-106-2

Overhaul Instructions - T.O. 12R5-4-106-3

DESCRIPTION OF TECH DATA FIELD DISCREPANCIES:

No significant discrepancies were discovered and the technical data is considered adequate.

DESIGN-FOR-REPAIR CONCEPT DEFINITION

TRAINING & PERSONNEL SKILLS LEVEL

DATE: 15 November 1978

DESCRIPTION OF SKILLS REQUIREMENTS:

The C-5A TACAN is maintained by a combined shop which supports all C-5A and C-141 navigation equipment. Authorized manning is as follows:

9 Levels - 2
7 Levels - 15
5 Levels - 59
3 Levels - 18
Civilians - 5

DESCRIPTION OF ASSIGNED SKILLS:

Assigned manning is as follows:

9 Levels - 0
7 Levels - 17
5 Levels - 39
3 Levels - 38
Civilians - 4

GENERAL COMMENTS:

The Navigation branch supervisors consider the Navigation Shop to be under manned. This problem is being aggravated by the additional workload created by the C-141A/AN/ARN-118 TACAN modification program presently in work at Travis, AFB.

DESIGN-FOR-REPAIR CONCEPT DEFINITION

TROUBLESHOOTING METHODS

DATE: 15 November 1978

DESCRIPTION OF ORGANIZATIONAL TROUBLESHOOTING METHODS:

Substitution techniques are used almost exclusively. Units are swapped between the two TACAN Sets in the C-5A.

DESCRIPTION OF INTERMEDIATE TROUBLESHOOTING METHODS:

- o Substitution - the LRU is installed in the hot mock-up and SRUs are substituted from a known good mock-up unit.
- o Signal Tracing/Probing - LRUs are also fault isolated in the hot mock-up environment using extenders, test instruments and technical data.

DESCRIPTION OF DEPOT TROUBLESHOOTING METHODS:

- o LRU Troubleshooting -
 - a. Substitution - same as Intermediate Level.
 - b. Signal tracing/probing - same as Intermediate Level
 - c. SRU Testing - suspected defective SRUs are pulled from LRU and tested on module test sets.
- o SRU Troubleshooting -
 - a. Substitution of circuit boards in the SRU
 - b. Signal tracing/probing

**DESIGN-FOR-REPAIR CONCEPT DEFINITION
FIELD EVALUATION REPORT**

DATE: 18 October 1978

BASE: Edwards AFB (16-18 October 1978)		WEAPON SYSTEM: F-16	
PERSONNEL CONTACTED: Major H. S. Souder (Chief of Maint.) Capt. McKittrick (F-16 Avionic Supervisor) Mr. H. J. Dietrich (F-16 Avionics Supervisor) MSGT Willie (NCOIC "I" Level Comm/Nav Branch) TSGT F. Miyamura (NCOIC "I" Level Nav Shop) TSGT Woelfl (NCOIC F-16 "O" Level C Shop)			
SUBSYSTEM CATEGORY: Navigation		WORK UNIT CODE: 71A00	
SUBSYSTEM NOMENCLATURE: AN/ARN-118 TACAN			
DESCRIPTION OF WEAPON SYSTEM MISSION: The mission of the weapon system is as a Tactical fighter to deliver aerial munitions. This weapon system is currently in flight test phase at Edwards AFB.			
DESCRIPTION OF SUBSYSTEM CAPABILITIES: The AN/ARN-118 TACAN provides bearing and range information on the horizontal situation indicator on either airborne (air-to-air mode) on ground (air-to-ground mode) beacons. BIT provides test headings and ranges.			
NUMBER OF LRU _s PER SUBSYSTEM: 4			
LRU NOMENCLATURE/PART NUMBER: Receiver/Transmitter - P/N 622-0507-001 Control Panel - P/N 622-0748-001 Mount - P/N 814557 Digital/Analog Adapter - P/N 622-1678-002			
WEAPON SYSTEM FLIGHT HOURS PER MONTH: N/A		SUBSYSTEM FLIGHT HOURS PER MONTH: N/A	
SUBSYSTEM GROUND OPERATING TIME PER FLIGHT HOUR: N/A		EVALUATOR: J. Green M. Cochran	

INSPECTION REQUIREMENTS (-6):

- 100 hr quality control inspection
- No power-on checks on aircraft
- No shop checks other than functional check following replacement of unit

DESCRIPTION OF SUBSYSTEM DESIGN CHARACTERISTICS FOR MAINTENANCE:

- Electronics packaged in three LRUs for simplified fault-isolation
- Sealed units which are opened only by Collins at factory
- System provided with BIT, operable from cockpit, for go-no go system check

DESCRIPTION OF SPECIAL MAINTENANCE AIDS OR LOCAL MODIFICATIONS:

None

MAINTENANCE CONCEPT - DESIGN:

- LRU replacement at "0" level: fault-isolation by substitution
- LRU functional check at "I" level using hot mock-up
- A reliability improvement warranty (RIW) contract with Collins for unit repair at factory for five year from purchase.

OPERATIONAL ENVIRONMENT

The tactical fighter will deploy using the bare base concept after introduction into Tactical Air Command (TAC) inventory.

Operational concepts for tactical air forces require a high degree of flexibility and mobility to attain proficiency in tactical operations. This capability must be established in the following areas:

- Quick-reactions deployment and employment anywhere in the world under any combat conditions
- Primary employment in limited war and special warfare operations
- Normal employment as a component of a joint force
- Operations of extended duration using a wide selection of weapons

See Continuation Sheet

MAINTENANCE ENVIRONMENT

The tactical fighter squadron is organized and manned for organization and field maintenance capability. Organizational level maintenance includes inspection, servicing, fault isolation, removal and replacement of components and system calibration. Servicing tasks encompass the loading and unloading of munitions. Field maintenance provides intermediate maintenance capability and is organized and capable of supporting the tactical squadrons. This capability is the same at the deployed base as at the home base and includes repair and testing of engines; local manufacture of parts; testing, calibration and repair of aircraft and aerospace ground equipment, assemblies and components; and inspection and repair which is beyond the capability of organizational level maintenance. In addition, a complete precision measurement equipment laboratory is available to support maintenance functions at home base and deployments to a Bare Base.

By necessity, a large portion of required maintenance, e.g., unscheduled/scheduled, must be accomplished during the hours of darkness in preparation for

See Continuation Sheet

NATURAL ENVIRONMENT

Climatic conditions can range throughout the full spectrum of weather. During Bare Base operations, hostility requirements dictate that all operations will be conducted on a 24-hour day, 7-day week basis. The maintenance environment is subjected to extreme climatic variances due to rapid response deployment requirements. The amount of variance encountered relates directly to the degree of maintenance efficiency which may be expected and subsequently the effectiveness of the fighting unit.

Flightline maintenance activities expose both men and equipment to the mercy of the elements. Maintenance is performed around the clock and personnel are exposed to further distraction from high noise levels. Shop maintenance conditions are superior to those experienced on the flightline; however, crowded conditions exist generating a continuing programmed requirement for 24 hour shift work.

See Continuation Sheet

DESIGN-FOR-REPAIR CONCEPT DEFINITION

CONTINUATION PAGE

DATE: 18 October 1978

Operational Environment (cont'd)

- Economical operation under any combat situation
- Rapid transition from one type of warfare to another
- Establish force increments of varying size and type for specialized missions

At a Bare Base deployment site the environment is identified by austere facilities, unfamiliar and severe climatic conditions, the increased tempo of operations, and personal emotional and physical stress. These bases range in capability from advanced terminals such as Orly in Paris on one extreme to narrow, weed-grown strips in Chad in Africa on the other. In addition, there are numerous other bases, where facilities for personnel support and general housekeeping are adequate, but the maintenance equipment is not equal to current advanced aircraft weapons systems.

Maintenance Environment (cont'd)

the next mission (sortie). Maintenance capability must exist regardless of the hour of the day or weather conditions. The flightline maintenance environment is far from ideal. Flightline maintenance personnel are subjected to distractions of jet engines in operation, taxiing aircraft and jet blast. Use of handbooks and schematics normally associated with flightline maintenance is externally difficult for the reasons stated. Shop maintenance (intermediate maintenance) operations are more extensive than flightline maintenance functions. Even though work requirements may generate a need for around the clock operations and facilities are crowded, work is normally performed in some type of shelter, building, etc.

Natural Environment (cont'd)

Climatic conditions of high humidity indirectly affect performance of electronic equipment to some degree. Extreme temperature has a greater effect on maintenance personnel than on equipment. Extremes in temperature and humidity are directly related to the magnitude of the problems encountered and the solutions required to support immediate flight operations.

DESIGN-FOR-REPAIR CONCEPT DEFINITION

ACCESSIBILITY OF AVIONICS

DATE: 18 October 1978

GENERAL DESCRIPTION:

- Upper TACAN antenna on skin behind canopy.
- Lower antenna below intake shared with UHF.
- Antenna switching in R/T unit.
- Base, adapter, R/T unit located under panel 2202.
- Control panel in left console in cockpit.
- Fuze for AN/ARC-118 located on back of base.
- Four connectors to remove base.

QUANTITATIVE VALUES:

Access to the R/T unit requires removal of 20 fasteners in panel 2202.

DESCRIBE SUBSYSTEM REMOVAL:

Upper antenna is four feet in front of refueling door. This has lead to damage (50 percent of total maintenance actions on AN/ARC-118) to the antenna assembly.

DESIGN-FOR-REPAIR CONCEPT DEFINITION

AGE OF SYSTEM & TECHNOLOGY

DATE: 18 October 1978

GENERAL DESCRIPTION:

TACAN units in F-16s at Edwards AFB are new but the design has been proven in other aircraft. The AN/ARC-118 represents state-of-art in TACAN equipment and embodies technology of the mid 1970's.

TYPE OF COMPONENTS USED:

In general, solid state discrete components are used with limited or no use of LSI, hybrids, or ICs.

TYPE OF WIRING AND INTERFACE USED:

R/T has connector on front with cable going to and integral within the mount. Digital/Analog Adapter has plug on back side of the LRU plugging into the mount. Mount has connectors tied to aircraft wiring.

SYSTEM DESIGN APPROACH (ANALOG, DIGITAL, SOFTWARE, ETC.):

Analog and digital signal processing. No software.

DESIGN-FOR-REPAIR CONCEPT DEFINITION

DEBRIEFING

DATE: 18 October 1978

DESCRIPTION OF THE DEBRIEFING FUNCTION:

The debriefing function operates independently of the "O" and "I" level Comm/Nav shops. System status is determined by aircrew at time of weapons system debriefing through appropriate entry on aircraft forms (781s).

DESCRIBE THE DEBRIEFING PROCEDURE:

- Aircrews enter write-ups in 781s
- Debriefers fill out AFFTC form 300 and assign job control numbers to write-ups
- AFFTC 300 copy goes to "O" level shops for aircraft history.

DESCRIBE DATA FLOW AND RECORDS:

AFTO 781 aircraft maintenance records.
AFFTC 300 debriefing record.
AFSC 258 on-aircraft maintenance record.
AFSC 258-4 on-aircraft and shop maintenance record.

DESIGN-FOR-REPAIR CONCEPT DEFINITION

DEPOT SUPPORT

DATE: 18 October 1978

DESCRIPTION OF DEPOT SUPPORT SCOPE:

Collins sold the AN/ARN-118 under a RIW contract. All units are repaired by Collins under a 5 year program.

DEPOT SUPPORT EFFECTIVENESS:

It was reported that the support of the TACAN under this RIW contract was adequate in meeting the operational mission.

COMMENTS:

NONE

DESIGN-FOR-REPAIR CONCEPT DEFINITION

(PRE, IN, POST) -FLIGHT INSPECTION

DATE: 18 October 1978

DESCRIPTION OF THE INSPECTIONS:

No inspections are performed by maintenance except, preflight checks are accomplished by aircrew.

FREQUENCY OF INSPECTIONS:

TACAN checks are accomplished each sortie as part of normal operations.

PURPOSE OF INSPECTIONS:

Preflight check provides go-no go check of TACAN.

COMMENTS:

TACAN is checked by aircrews using local station.

DESIGN-FOR-REPAIR CONCEPT DEFINITION

LEVEL OF BASE REPAIR

DATE: 18 October 1978

DESCRIPTION OF ORGANIZATIONAL REPAIR:

1. UNSCHEDULED:

Remove and replace LRUs.

2. SCHEDULED:

NONE

DESCRIPTION OF INTERMEDIATE REPAIR:

1. UNSCHEDULED:

No intermediate repair authorized.

2. SCHEDULED:

NONE

DESCRIPTION OF DEPOT REPAIR:

1. UNSCHEDULED:

The AN/ARN-118 TACAN is repair under a reliability improvement warranty contract.

2. SCHEDULED:

NONE

DESIGN-FOR-REPAIR CONCEPT DEFINITION

MAINTENANCE DATA COLLECTION DOCUMENTATION & FEEDBACK SYSTEM

DATE: 18 October 1978

GENERAL DESCRIPTION:

The maintenance data collection system is designed for the unique environment of the joint test force. Air Force Flight Test Center (AFFTC) forms and Air Force System Command (AFSC) forms are used to record maintenance data.

IMPLEMENTED METHODS:

1. The aircrew enters discrepancies on the AFTO 781.
2. Debriefing records discrepancies on the AFFTC 300 form.
3. Flightline maintenance (when no LRU is pulled) is recorded on the AFSC 258 form.
4. Flightline and shop maintenance is recorded on the AFSC 258-4 form when a unit is pulled.

METHOD(S) EFFECTIVENESS:

The AFFTC form 300 and AFSC form 258-4 provides a record of essential maintenance data. The form 300s provides an aircraft maintenance history while the form 258-4s provide a LRU maintenance history.

COMMENTS:

The AFSC form 258 appears to be redundant. All data logged on the 258 can be logged on the 258-4. However, the stated purpose of the 258 is to save paper

DESIGN-FOR-REPAIR CONCEPT DEFINITION

MAINTAINABILITY CHARACTERISTICS OF EQUIPMENT DESIGN

DATE: 18 October 1978

GENERAL DESCRIPTION OF SUBSYSTEM FEATURES:

- Electronics packaged in LRUs.
- BIT operable from cockpit.
- Simple LRU replacement.
- The mount, adapter, and R/T can be replaced as a unit.
- Antenna switching is incorporated in R/T unit.

QUANTITATIVE VALUES:

(1) MTBF -

(2) MTBM -

(3) MMH/FH -

(4) MTTR - These data values are not available from raw data and would be insignificant at this point in the acquisition phase.

QUALITATIVE FEATURES:

LRUs are easily replaced in aircraft. Control unit in cockpit replaceable in 5 minutes. Units under access door 2202 require approximately 10 minutes to access.

COMMENTS:

BIT is not considered essential for flightline maintenance. TACAN tests can be accomplished on local stations and with a simple hand-held tester.

DESIGN-FOR-REPAIR CONCEPT DEFINITION

MAINTENANCE ORGANIZATION

DATE: 18 October 1978

GENERAL DESCRIPTION:

- F-16 flight testing is directly supported by a joint USAF - General Dynamics organization.
- USAF personnel from TAC are assigned to the 4486th which provides the "O" level support.
- The 6515th provide "I" level support and is a host unit. The 6515th is an AFSC organization.

MAINTENANCE ORGANIZATION FLOW CHART:

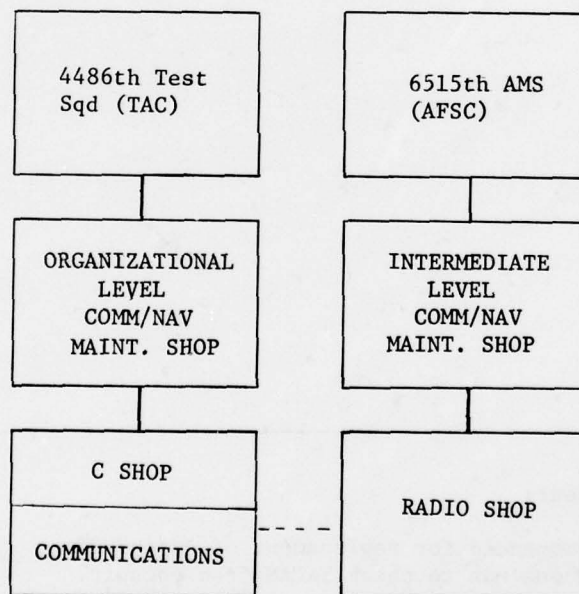

DESIGN-FOR-REPAIR CONCEPT DEFINITION

ORGANIZATIONAL LEVEL AGE

DATE: 18 October 1978

DESCRIPTION OF AGE:

TACAN Ramp Test Set (MTS-100), Republic Electronic Industries Corp: 3.5 lb hand-held tester for range, bearing and sensitivity (both air-to-ground and air-to-air modes). Operates on battery power.

PURPOSE OF AGE:

The organizational level test set: checks range, bearing, receiver sensitivity and power out.

COMMENTS:

Special Test Equipment:

MTS-100 is recommended for replacement of AN/ARM-25.
MTS-100 allows one man to check TACAN from cockpit.

AN/ASM-23 Problems:

- 1) Weight necessitates 2 man carry (70 lbs)
- 2) Low reliability; BIT gives false indications

It should be noted that the test equipment used in support of the TACAN at Edwards does not represent a tactical configuration.

DESIGN-FOR-REPAIR CONCEPT DEFINITION

PREVENTIVE MAINTENANCE

DATE: 18 October 1978

GENERAL DESCRIPTION:

None other than 100 hour quality control inspection of wiring, connectors

PREVENTIVE MAINTENANCE REQUIREMENT SOURCE:

NONE

COMMENTS:

No power on checks are performed on a scheduled basis. TACANs requiring adjustments and becoming marginal will not be detected until reported by aircrew. Communication/navigation personnel do not consider this a problem.

DESIGN-FOR-REPAIR CONCEPT DEFINITION

TECHNICAL ORDERS

DATE: 18 October 1978

DESCRIPTION OF TECH DATA REQUIREMENTS:

1F-16A-2-34GS-00-1	NAV General System Description
1F-16A-2-34FI-00-1	Fault-Isolation NAV
1F-16A-2-34JG-50-1	NAV System, TACAN and A-G/IFF Partial Job Guide
1F-16A-2-34JG-00-1	NAV System Job Guide
1F-16A-6	Scheduled Inspection and Maintenance Requirements
1F-16A-06	Work Unit Code Manual
12R5-2-ARN118-1	(Collins) Operation and Maintenance Instructions with IPB

DESCRIPTION OF TECH DATA FIELD DISCREPANCIES:

Full scale development manuals are presently being utilized. All known discrepancies are being corrected as discovered at organizational level maintenance.

Collins manual is presently being utilized in shop in place of official technical orders.

DESIGN-FOR-REPAIR CONCEPT DEFINITION

TRAINING & PERSONNEL SKILLS LEVEL

DATE: 18 October 1978

DESCRIPTION OF SKILLS REQUIREMENTS:

Training and personnel skills level observations represented test personnel at Edwards AFB and does not reflect a tactical unit.

DESCRIPTION OF ASSIGNED SKILLS:

Not applicable

GENERAL COMMENTS:

NONE

DESIGN-FOR-REPAIR CONCEPT DEFINITION

TROUBLESHOOTING METHODS

DATE: 18 October 1978

DESCRIPTION OF ORGANIZATIONAL TROUBLESHOOTING METHODS:

1. Test Set (STE: MTS-100)
2. Built-in-test
3. Substitution of LRU.

DESCRIPTION OF INTERMEDIATE TROUBLESHOOTING METHODS:

Functional testing in hot-mockup at the test center at Edwards AFB.

DESCRIPTION OF DEPOT TROUBLESHOOTING METHODS:

Accomplished by Collins. No data available.

DESIGN FOR REPAIR CONCEPT DESCRIPTION
FIELD EVALUATION REPORT

DATE: 1-10-68

PROJECT NUMBER: 62-10000-1000	WEAPON SYSTEM: F-111B
SECTION III RECONNAISSANCE SUBSYSTEM	
DESCRIPTION OF SUBSYSTEM: This subsystem is designed to provide the F-111B with the capability to perform reconnaissance missions. It consists of a sensor suite, a data processing unit, and a display unit. The sensor suite includes a forward-looking infrared (FLIR) sensor, a television camera, and a laser altimeter. The data processing unit is located in the fuselage and processes the sensor data. The display unit is located in the cockpit and provides the pilot with a visual representation of the sensor data.	
FUNCTIONAL REQUIREMENTS: The subsystem must be able to detect, identify, and track ground targets. It must also be able to provide accurate altitude information for terrain clearance. The subsystem must be able to operate in all weather conditions and at altitudes up to 50,000 feet.	
DESIGN CONSIDERATIONS: The subsystem must be designed to be lightweight and compact, as it will be installed in the F-111B. It must also be able to withstand the high g-forces and temperatures encountered during flight. The subsystem must be able to be maintained and repaired in the field.	
TESTING AND EVALUATION: The subsystem was tested in a series of flight tests. The tests demonstrated that the subsystem is capable of performing reconnaissance missions in all weather conditions and at altitudes up to 50,000 feet. The subsystem was found to be reliable and easy to maintain.	
CONCLUSIONS: The subsystem is a successful design for the F-111B. It provides the aircraft with the capability to perform reconnaissance missions in all weather conditions and at altitudes up to 50,000 feet. The subsystem is reliable and easy to maintain.	

**DESIGN-FOR-REPAIR CONCEPT DEFINITION
FIELD EVALUATION REPORT**

DATE: 2 October 1978

BASE: Cannon AFB, New Mexico (2-5 October 1978)		WEAPON SYSTEM: F-111D
PERSONNEL CONTACTED: Lt. Col. M. Wielunski, Job Control Major K. B. Burns, CC/27 CRS Commander Captain J. W. Rodgers, MAC/Maintenance Supv. CMS. H. L. Olden, MAC/Maintenance Supt. *MSgt. Clayton, MACL/Mobility *SSgt. H. A. Van Olden, MACAP/Airborne Photo System 2nd Lt. Carmela E. Giugliano, MACA/Int. Avn. Maint Br. Supv. *Mr. D. E. Edward, Ogden ALC Shop Foreman * Strike Camera		
SUBSYSTEM CATEGORY: Reconnaissance		WORK UNIT CODE: 77A00
SUBSYSTEM NOMENCLATURE: Strike Camera		
DESCRIPTION OF WEAPON SYSTEM MISSION: The mission of the weapon system is as a tactical fighter/bomber to deliver aerial munitions on designated ground targets.		
DESCRIPTION OF SUBSYSTEM CAPABILITIES: The still picture camera KB-18A is of the moving film type used for daylight low level photography. It is mounted in a vertical position and will normally provide a fore to aft photographic coverage of 180° along the line-of-flight and a field angle of 41° throughout the scan. The major components of the camera system are the camera body LB-15B, magazine LB-16A and the camera control.		
NUMBER OF LRU _s PER SUBSYSTEM: Three		
LRU NOMENCLATURE/PART NUMBER: Camera Body LB-15B P/N 1193B88 Film Magazine LB-16A P/N 1193C50 Camera Control, LB-17A P/N 1193D50		
WEAPON SYSTEM FLIGHT HOURS PER MONTH: 40.0		SUBSYSTEM FLIGHT HOURS PER MONTH: 3.33
SUBSYSTEM GROUND OPERATING TIME PER FLIGHT HOUR: 0.002		EVALUATOR: Gerkin King

INSPECTION REQUIREMENTS (-6): Past Requirements Valid thru August 1978.

500 Hour Major Inspection

1. Operational Check
2. Ensure Installation per T.O.1F-111D-2-19-3, Section 4.

Present requirements valid since Aug. 78 and in operation since Oct. 1977.

125, 250, 375 Hour Inspection

See inspection card attached for minor inspection.

500 Hour Inspection

See inspection card attached for major inspection

DESCRIPTION OF SUBSYSTEM DESIGN CHARACTERISTICS FOR MAINTENANCE:

Operational checkout of system using a designed built-in test switch in the control box.

DESCRIPTION OF SPECIAL MAINTENANCE AIDS OR LOCAL MODIFICATIONS:

None

MAINTENANCE CONCEPT - DESIGN:

- Organizational Level - Remove/replace LRU
Load/unload Film
- Intermediate Level: - Fault Isolation to SRU
SRU Repair to Piece Part Level
- Depot: - Limited primarily to optical system and LRU repair
beyond capability of intermediate maintenance

DESIGN-FOR-REPAIR CONCEPT DEFINITION

CONTINUATION PAGE

DATE: 2 October 1978

CARD NO.	WORK AREA(S)	TYPE MECH ROR	MECH NO.	CARD TIME	PUBLICATION NUMBER AND DATE	CHANGE RECORD		
1/3-013	1	PHOTO		4:00	1F-111A-6WC-2			
MAN MINUTES	WORK ARE.	WORK UNIT CODE FOR DISCREPANCY		MINOR INSP (125/375 Hours)	INSPECTION REQUIREMENTS	ELEC POWER	SERVICE	CARD NO.
		SYS	SUB-SYS AND COMP			ON		1/3-013
020	1	77	A--	1. Inspect strike camera for proper installation required by T.O. 1F-111D-2-19-3 section 4.				
010	1	77	AAF	2. Inspect strike camera control panel for security.				
010	1	77	AAE	3. Inspect strike camera control box for security.				
150	1	77	A--	4. Remove strike camera body and film magazine to shop for cleaning and bench check.				
030	1	77	A--	5. Reinstall strike camera body and film magazine.				
020	1	77	AOO	6. Strike camera operational check.				

CARD NO.	WORK AREA(S)	TYPE MECH ROR	MECH NO.	CARD TIME	PUBLICATION NUMBER AND DATE	CHANGE RECORD		
4-076	1	PHOTO		6:00	1F-111A-6WC-2			
MAN MINUTES	WORK ARE.	WORK UNIT CODE FOR DISCREPANCY		MAJOR INSP (500 Hours)	INSPECTION REQUIREMENTS	ELEC POWER	SERVICE	CARD NO.
		SYS	SUB-SYS AND COMP			ON		4-076
020	1	77	A--	1. Inspect strike camera for proper installation required by T.O. 1F-111D-2-19-3 section 4.				
010	1	77	AAF	2. Inspect strike camera control panel for security.				
100	1	77	AAE	3. Remove strike camera control box to shop for bench check.				
150	1	77	A--	4. Remove strike camera body and film magazine to shop for cleaning and bench check.				
030	1	77	AAE	5. Reinstall strike camera control box.				
030	1	77	A--	6. Reinstall strike camera body and film magazine.				
020	1	77	AOO	7. Strike camera operational check.				
CARD NO.	WORK AREA(S)	TYPE MECH ROR	MECH NO.	CARD TIME	PUBLICATION NUMBER AND DATE	CHANGE RECORD		
4-076	1	PHOTO		6:00	1F-111A-6WC-2			

DESIGN-FOR-REPAIR CONCEPT DEFINITION

CONTINUATION PAGE

DATE: 2 October 1978

CARD NO.	WORK AREA(S)	TYPE MECH RQR	MECH NO.	CARD TIME	PUBLICATION NUMBER AND DATE	CHANGE RECORD		
4-076	1	PHOTO		:40	1F-111A-6WC-2			
MAN MINUTES	WORK AREA	WORK UNIT CODE FOR DISCREPANCY		MAJOR INSP (500 Hours)	INSPECTION REQUIREMENTS	ELEC POWER	SERVICE	CARD NO.
		SYS	SUB-SYS AND COMP					
020	1	77	A --	1. Strike camera operational Check.	2. Strike camera for proper installation required by T.O. 11B29-3-25-2,, TABLE 4-4, ITEM 4.	ON		4-076
020	1	77	A--					
CARD NO.	WORK AREA(S)	TYPE MECH RQR	MECH NO.	CARD TIME	PUBLICATION NUMBER AND DATE	CHANGE RECORD		
4-076	1	PHOTO		:40	1F-111A-6WC-2			

OPERATIONAL ENVIRONMENT

Tactical fighter/bomber deploys using the bare base concept.

Operational concepts for tactical air forces requires a high degree of flexibility and mobility to attain proficiency in tactical operations. This capability must be established in the following areas:

- o Quick-reactions deployment and employment anywhere in the world under any combat conditions
- o Primary employment in limited war and special warfare operations
- o Normal employment as a component of a joint force
- o Operations of extended duration using a wide selection of weapons
- o Economical operation under any combat situation
- o Rapid transition from one type of warfare to another
- o Establish force increments of varying size and type for specialized missions.

(See attached continuation page)

MAINTENANCE ENVIRONMENT

The tactical fighter squadron is organized and manned for organizational and field maintenance capability. Organizational level maintenance includes inspection, servicing, fault isolation, removal and replacement of components and system calibration. Servicing tasks encompass the loading and unloading of munitions. Field maintenance provides intermediate maintenance capability and is organized and capable of supporting the tactical squadrons. This capability is the same at the deployed base as at the home base and includes repair and testing of engines; local manufacture of parts; testing, calibration and repair of aircraft and aerospace ground equipment, assemblies and components; and inspection and repair which is beyond the capability of organizational level maintenance. In addition, a complete precision measurement equipment laboratory is available to support maintenance functions at home base and deployments to a Bare Base.

By necessity, a large portion of required maintenance, e.g., unscheduled/scheduled, must be accomplished during the hours of darkness in preparation for the next mission (sortie). Maintenance capability must exist regardless of the hour of the
(continued on Page 2)

NATURAL ENVIRONMENT

Climatic conditions can range throughout the full spectrum of weather. During Bare Base operations, hostility requirements dictate that all operations will be conducted on a 24-hour day, 7-day week basis. The maintenance environment is subjected to extreme climatic variances due to rapid response deployment requirements. The amount of variance encountered relates directly to the degree of maintenance efficiency which may be expected and subsequently the effectiveness of the fighting unit.

Flight-line maintenance activities expose both men and equipment to the mercy of the elements. Maintenance is performed around the clock and personnel are exposed to further distraction from high noise levels. Shop maintenance conditions are superior to those experienced on the flightline; however, crowded conditions exist generating a continuing programmed requirement for 24 hour shift work.

(continued on Page 2)

DESIGN-FOR-REPAIR CONCEPT DEFINITION

CONTINUATION PAGE

DATE: 31 October 1978

Operational Environment (continued from Page 1)

At a Bare Base deployment site the environment is identified by austere facilities, unfamiliar and severe climatic conditions, the increased tempo of operations, and personal emotional and physical stress. These bases range in capability from advanced terminals such as Orly in Paris on one extreme to narrow, weed-grown strips in Chad in Africa on the other. In addition, there are numerous other bases, where facilities for personnel support and general housekeeping are adequate, but the maintenance equipment is not equal to current advanced aircraft weapons systems.

Maintenance Environment (continued from Page 1)

day or weather conditions. The flightline maintenance environment is far from ideal. Flightline maintenance personnel are subjected to distractions of jet engines in operation, taxiing aircraft and jet blast. Use of handbooks and schematics normally associated with flightline maintenance is externally difficult for the reasons stated. Shop maintenance (intermediate maintenance) operations are more extensive than flightline maintenance functions. Even though work requirements may generate a need for around the clock operations and facilities are crowded, work is normally performed in some type of shelter, building, etc.)

Natural Environment (continued from Page 1)

Climatic conditions of high humidity indirectly affect performance of electronic equipment to some degree. Extreme temperature has a greater effect on maintenance personnel than on equipment. Extremes in temperature and humidity are directly related to the magnitude of the problems encountered and the solutions required to support immediate flight operations.

DESIGN-FOR-REPAIR CONCEPT DEFINITION

ACCESSIBILITY OF AVIONICS

DATE: 2 October 1978

GENERAL DESCRIPTION:

1. Strike camera and film magazine are accessed via approximately 18" x 18" hinged panel in forward bottom of nose.
2. Camera control unit is located in left forward avionics compartment.

QUANTITATIVE VALUES:

1. Access to camera and film cartridge, including film loadup/removal/inspection/securing access panel requires 15 minutes.
2. Access to control unit, including opening access panel to left forward avionics compartment removal/replacing control unit, BIT checking and closing access panel requires 20 minutes.

DESCRIBE SUBSYSTEM REMOVAL:

1. Panel access to Strike camera swings down and to the side after disengaging nine quick-release fittings.
2. Camera with film magazine attached swings down and forward after disengaging one quick release level.
3. Film cartridge is removed from camera after release of two snap-lock hinges.
4. Camera is removed after disengaging two quick-release hinges.
5. Camera control unit is removed from left forward avionics compartment. Removal is hampered by presence of wire bundles.

AD-A080 496

HUGHES AIRCRAFT CO CANOGA PARK CALIF MISSILE SYSTEMS--ETC F/G 1/3
DESIGN-FOR-REPAIR CONCEPT DEFINITION VOLUME III. FIELD EVALUATI--ETC(U)
AUG 79 F A GERKIN, J L GREEN, J M KING F33615-78-C-1461

UNCLASSIFIED

MSG-92A5-VOL-3

AFAL-TR-79-1130-VOL-3

NL

2 OF 3
AD
A080496



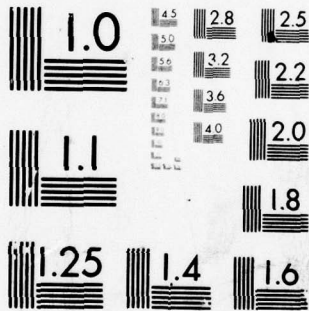

MICROCOPY RESOLUTION TEST CHART
NATIONAL BUREAU OF STANDARDS-1963-A

DESIGN-FOR-REPAIR CONCEPT DEFINITION

AGE OF SYSTEM & TECHNOLOGY

DATE: 3 October 1978

GENERAL DESCRIPTION:

The design of the strike camera system was built and installed on such aircraft as the F-100, F-105, F-111, F-4, A-7, OV-10 and UH-1. The design reflects technology in excess of 10 years old.

TYPE OF COMPONENTS USED:

Discrete Solid State Components
Electro-Mechanical Components
Fixed Optical Len/Prism System

TYPE OF WIRING AND INTERFACE USED:

Interface - Quick-disconnect connectors
 - SRU plug-in printed circuit card
Wiring - Wiring harnesses, bundles using standard multi-strand conduit

SYSTEM DESIGN APPROACH (ANALOG, DIGITAL, SOFTWARE, ETC.):

Design - Analog

DESIGN-FOR-REPAIR CONCEPT DEFINITION

DEBRIEFING

DATE: 2 October 1978

DESCRIPTION OF THE DEBRIEFING FUNCTION:

The debriefing function operates independently from the strike camera shop. The strike camera system status is determined by the aircrew at time of weapon system debriefing through appropriate entry into the aircraft forms.

DESCRIBE THE DEBRIEFING PROCEDURE:

1. Aircrew determines operational status
2. Aircrew writes strike camera discrepancies in aircraft forms
3. Debriefing function relays system status to job control
4. Job control notifies camera shop on non-functioning systems

DESCRIBE DATA FLOW AND RECORDS:

Camera shop completed AFTO 349 on maintenance action and this form enters the AFM 66-1 data collection system.

DESIGN-FOR-REPAIR CONCEPT DEFINITION

DEPOT SUPPORT

DATE: 3 October 1978

DESCRIPTION OF DEPOT SUPPORT SCOPE:

Depot support for the strike camera system consists of piece part and SRU.

DEPOT SUPPORT EFFECTIVENESS:

This camera system is adequately supported with spares to support the operational mission.

COMMENTS:

DESIGN-FOR-REPAIR CONCEPT DEFINITION

(PRE, IN, POST) -FLIGHT INSPECTION

DATE: 2 October 1978

DESCRIPTION OF THE INSPECTIONS:

None

FREQUENCY OF INSPECTIONS:

None

PURPOSE OF INSPECTIONS:

None

COMMENTS:

From a operational position:

1. The film magazine is loaded based on the daily flying requirements
2. The film magazine is removed from the aircraft upon return from the mission.

DESIGN-FOR-REPAIR CONCEPT DEFINITION

LEVEL OF BASE REPAIR

DATE: 2 October 1978

DESCRIPTION OF ORGANIZATIONAL REPAIR:

1. UNSCHEDULED:

Remove/Replace LRU

2. SCHEDULED:

125, 250, 375, 500 hours phase inspection

DESCRIPTION OF INTERMEDIATE REPAIR:

1. UNSCHEDULED:

- a. Remove/replace SRU
- b. Remove/replace piece part

2. SCHEDULED:

125, 250, 375, 500 hour phase inspection

DESCRIPTION OF DEPOT REPAIR:

1. UNSCHEDULED:

- a. Repair of SRU
 - b. Repair of LRU beyond the capability of intermediate maintenance
- The depot uses GPATS to fault isolate and test SRU and LRU. Also, a collimator is used to verify optical resolution.

2. SCHEDULED:

None

DESIGN-FOR-REPAIR CONCEPT DEFINITION

MAINTAINABILITY CHARACTERISTICS OF EQUIPMENT DESIGN

DATE: 2 October 1978

GENERAL DESCRIPTION OF SUBSYSTEM FEATURES:

Solid state design with quick connect/disconnect cable connectors and hinged fasteners with strike latches to facilitate LRU installation/removal. Plug-in PCC (3) permit fault isolation of SRU's subsystem BIT (self-test) activated at camera control unit.

QUANTITATIVE VALUES:

- | | | |
|---|---|---|
| (1) MTBF - 720 Hours | (2) MTBM - 66.4 Hours @
Organizational Level | (3) MMH/FH - 0.09 Combined
Organizational & Inter-
mediate Levels |
| (4) MTTR - 1.2 Hours @ Organizational Level
1.4 Hours @ Intermediate Level | (5) MTBD - 72.3 Hours @ Organ-
izational Level | |

All values are from AFM 66-1 data.

QUALITATIVE FEATURES:

- o Subsystem has exhibited very high reliability - in excess of 98% over 21 months.
- o Easy access to LRU's in A/C - some difficulty encountered in removal of control unit due to interference with a cable assembly.

COMMENTS:

- o BIT/self-test requires two people: one person to activate and monitor BIT at the control unit and one person at the camera bay (station 165) to visually monitor camera operation. Maintenance personnel would prefer co-location of control unit in camera bay to simplify maintenance and BIT.
- o Camera is not gyro-stabilized - when A/C rolls greater than 20-1/2° there is loss of FOV (field of view).
- o Difficulty is encountered when aligning 1J1 connector to camera body (required when connector is removed for maintenance or to permit access to camera drive assembly).
- o Maintenance personnel would prefer plug-in vice soldered connections for PCC BIT-piece parts.
- o The temperature control switch (Item 13, page 4-95, T.O. 1F-111D-2-151) is extremely difficult to access. Located on the camera compartment door, access to the switch is hampered due to the necessity to remove a camera compartment temperature control - heater fan.

(See continuation page 2)

DESIGN-FOR-REPAIR CONCEPT DEFINITION

CONTINUATION PAGE

DATE: 2 October 1978

COMMENTS: (continued from Page 1)

Maintainability Characteristics of Equipment Design:

- o Test readings of the Camera Test Set (LS-83A) are reported to be erratic by maintenance personnel. This situation apparently exists with or without test set maintenance/calibration.
- o Maintenance personnel consider that subsystem operation would be more efficient if the photo film were replaced by video tape.

DESIGN-FOR-REPAIR CONCEPT DEFINITION

MAINTENANCE DATA COLLECTION DOCUMENTATION & FEEDBACK SYSTEM

DATE: 2 October 1978

GENERAL DESCRIPTION:

The maintenance data collection is in accordance with the procedure of AFM 66-1. This regulation includes mainly organizational changes as it differs to AFR 66-5.

IMPLEMENTED METHODS:

Data are collected on the AFTO 349 form. The data are keypunched from the AFTO 349 and processed to the applicable ALC maintenance data activity.

METHOD(S) EFFECTIVENESS:

The system is effective, but because the camera system is highly reliable and has a low utilization rate, this system is not one that needs constant review and analysis. As such, the feedback of information is not provided to the shop from the maintenance analysis function of the Deputy Commander for Maintenance (DCM).

COMMENTS:

If the camera shop needed the information to help define maintenance problem areas, the information would be analyzed and provided to the maintenance activity.

DESIGN-FOR-REPAIR CONCEPT DEFINITION

MAINTENANCE ORGANIZATION

DATE: 3 October 1978

GENERAL DESCRIPTION:

The maintenance organization is in accordance with AFR 66-5.

MAINTENANCE ORGANIZATION FLOW CHART:

The Camera Shop activity is part of the component repair squadron and supports both organizational and intermediate maintenance requirements. See attached charts.

DESIGN-FOR-REPAIR CONCEPT DEFINITION

CONTINUATION PAGE

DATE: 3 October 1978

(Maintenance Org. Flow Chart)

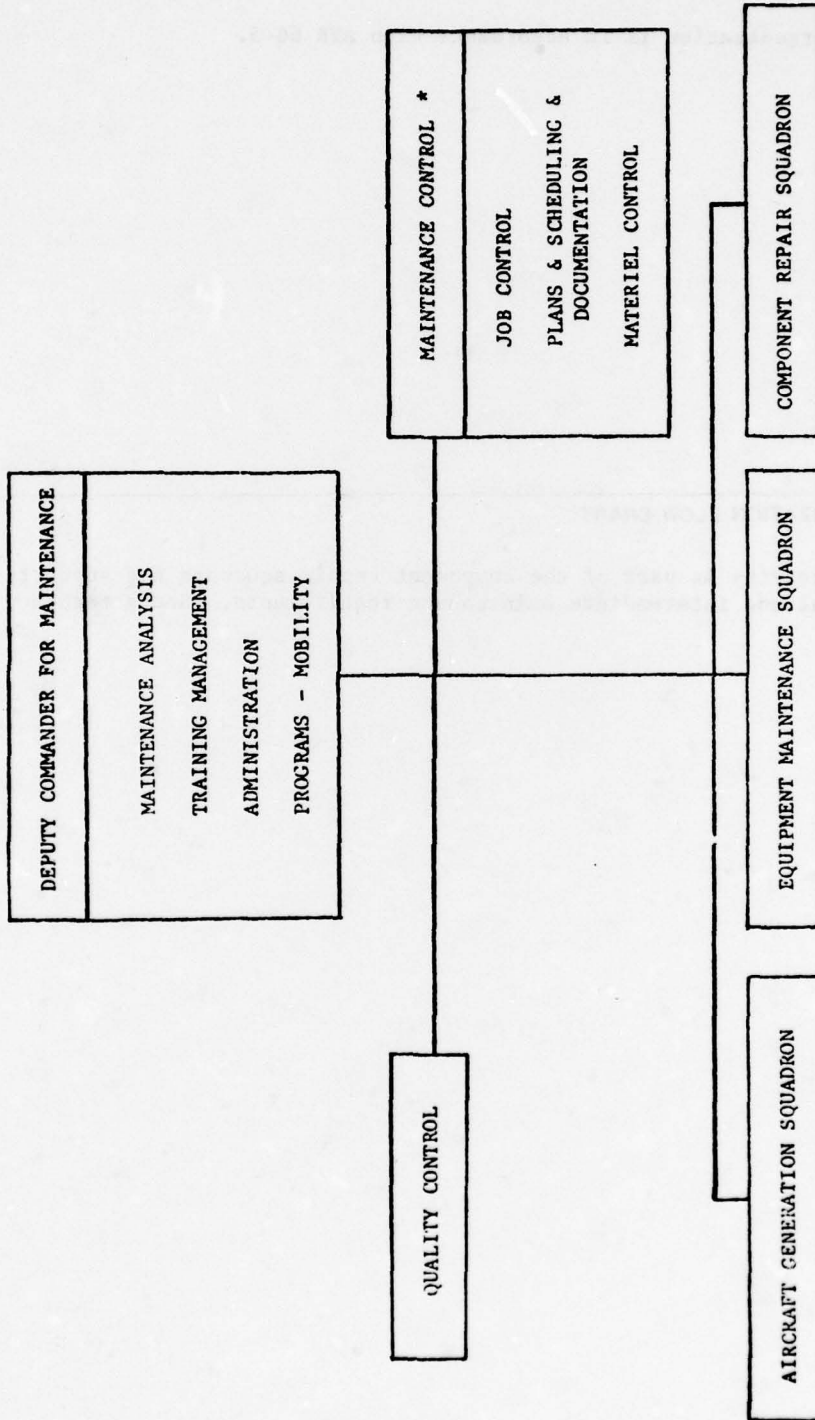

* May include Munitions Control

DESIGN-FOR-REPAIR CONCEPT DEFINITION

CONTINUATION PAGE

DATE: 3 October 1978

(Maintenance Org. Flow Chart)

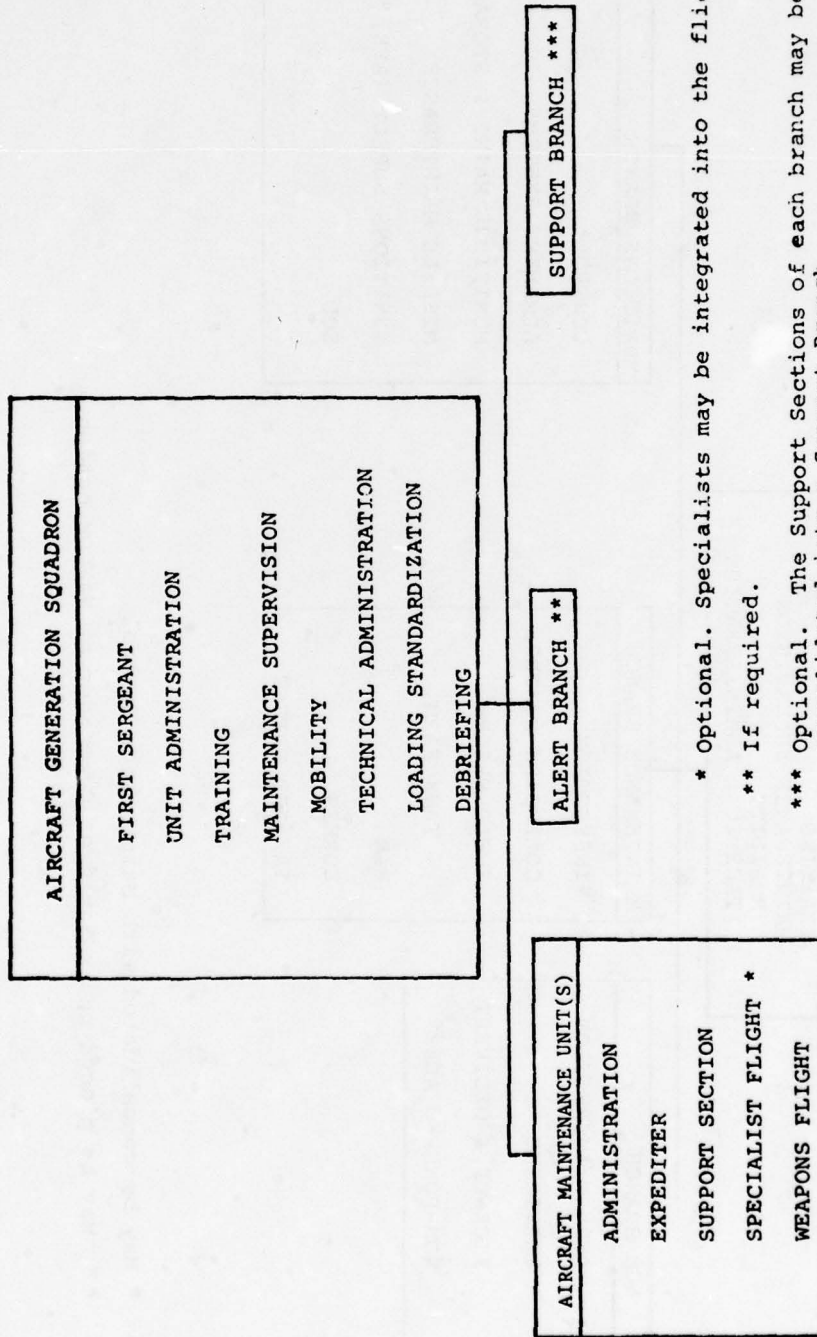

* Optional. Specialists may be integrated into the flights.
 ** If required.
 *** Optional. The Support Sections of each branch may be consolidated into a Support Branch.

DESIGN-FOR-REPAIR CONCEPT DEFINITION

CONTINUATION PAGE

DATE: 3 October 1978

(Maintenance Org. Flow Chart)

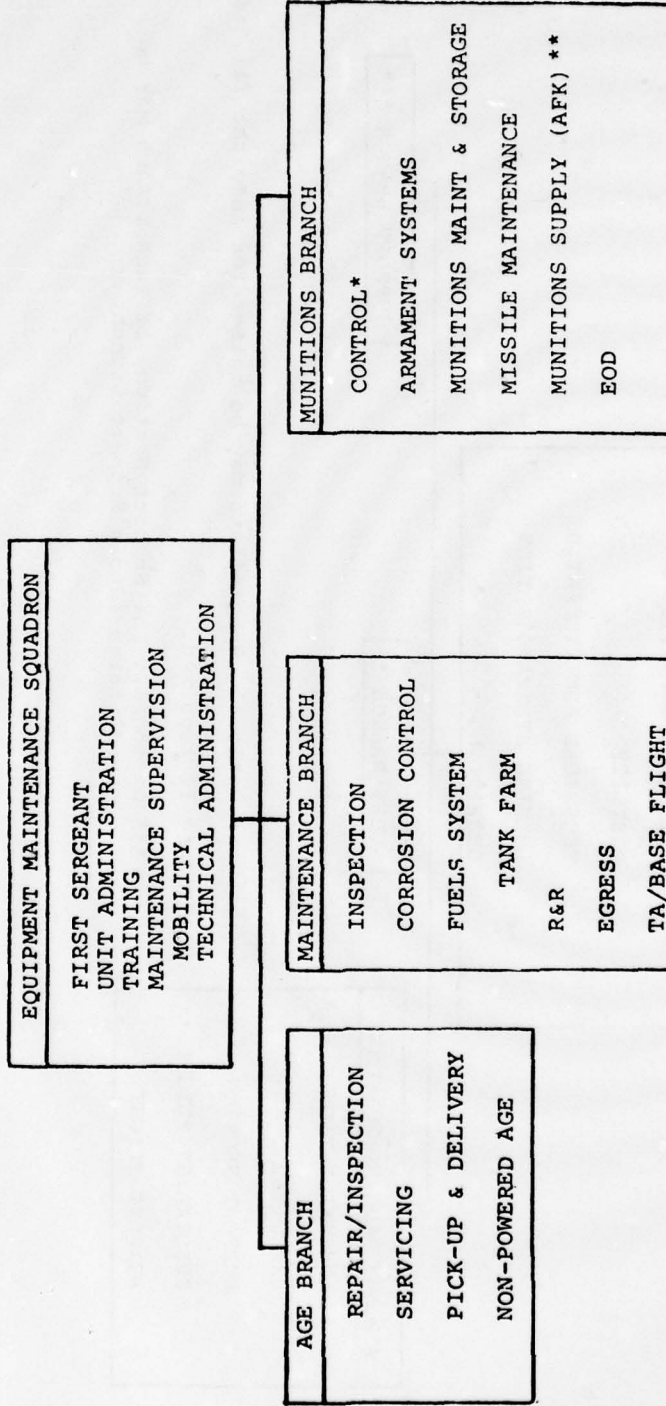

* May be consolidated with Maintenance Control
 ** May be placed under Squadron Commander at MAJCOM option.

DESIGN-FOR-REPAIR CONCEPT DEFINITION

CONTINUATION PAGE

DATE: 3 October 1978

(Maintenance Org. Flow Chart)

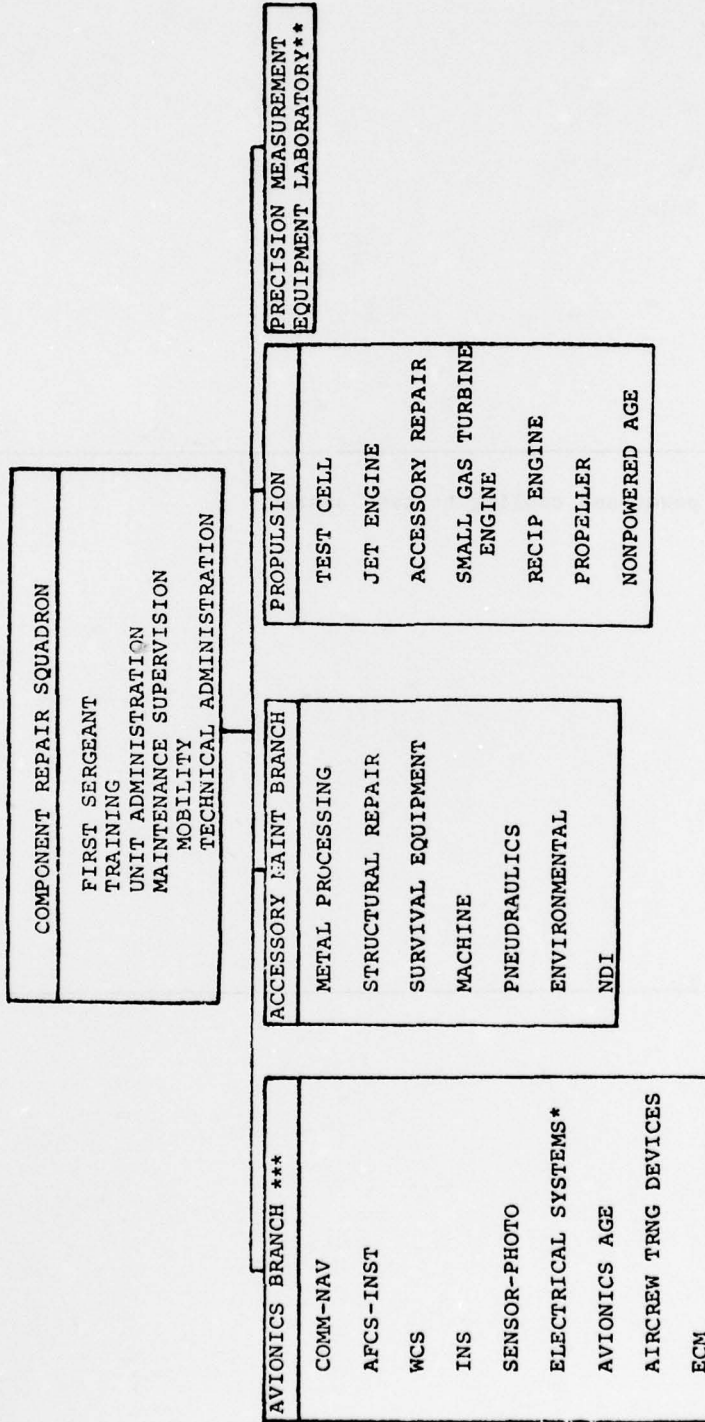

* May be located in the Accessory Maintenance Branch (as determined by the MAJCOM/LGM)

** May be consolidated with the Avionics Branch

*** See figure 1-9 for the organization of the Avionics Branch if both conventional and integrated avionics systems are supported.

DESIGN-FOR-REPAIR CONCEPT DEFINITION

ORGANIZATIONAL LEVEL AGE

DATE: 2 October 1978

DESCRIPTION OF AGE:

1. No Maintenance AGE
2. Ground Power Unit
3. A/C Supply

PURPOSE OF AGE:

1. Provide required power and cooling to test system

COMMENTS:

DESIGN-FOR-REPAIR CONCEPT DEFINITION

PREVENTIVE MAINTENANCE

DATE: 3 October 1978

GENERAL DESCRIPTION:

125, 200, 375, 500 hour phase inspection

PREVENTIVE MAINTENANCE REQUIREMENT SOURCE:

T.O.1F-11A-6WC-2 See phase inspection cards

COMMENTS:

These preventive maintenance tasks are performed when the weapon system is scheduled for other phase inspections.

DESIGN-FOR-REPAIR CONCEPT DEFINITION

TECHNICAL ORDERS

DATE: 3 October 1978

DESCRIPTION OF TECH DATA REQUIREMENTS:

Flightline - 1F-111D-2-15-1
1F-111D-2-19-3

Shop - 10A1-6-6-1
-2
-3

Storage of
Film - 10J-1-4
1F-111D-6
1F-111D-06

AGE (LS-83A)- 33D10-36

Included - Work card checklists

DESCRIPTION OF TECH DATA FIELD DISCREPANCIES:

The field technical data is adequate to support the strike camera system.

DESIGN-FOR-REPAIR CONCEPT DEFINITION

TRAINING & PERSONNEL SKILLS LEVEL

DATE: 3 October 1978

DESCRIPTION OF SKILLS REQUIREMENTS:

The authorized personnel for the camera shop are as follows:

2 ea, SSgt 7 level
2 ea. SGT 5 level
2 ea. Airman 5 level
2 ea. Airman 3 level

DESCRIPTION OF ASSIGNED SKILLS:

1 ea. MSgt. 7 level - Duty is in mobility
1 ea. SSgt. 5 level
2 ea. Airman 5 level
3 ea. Airman 3 level

GENERAL COMMENTS:

Personnel enter this career field from technical school as 3 levels and gain their basic knowledge on the system through OJT at the operational unit. This approach is adequate in support of the camera system. The integration of the female technicians into the maintenance complex is wide spread and requires reevaluation of the human factor aspects of the equipment/support system design. It was indicated that more attention is needed in manning to rank and skill level.

DESIGN-FOR-REPAIR CONCEPT DEFINITION

TROUBLESHOOTING METHODS

DATE: 2 October 1978

DESCRIPTION OF ORGANIZATIONAL TROUBLESHOOTING METHODS:

1. Accomplished through substitution of like item (LRU)
2. Wiring problems in the aircraft are repaired by the electric shop.

DESCRIPTION OF INTERMEDIATE TROUBLESHOOTING METHODS:

1. Accomplished through substitution of like item (SRU) and piece part
2. AN/PSM-6
3. VTVM
4. LS-83A (Test Set, Camera System)

DESCRIPTION OF DEPOT TROUBLESHOOTING METHODS:

The depot uses the GPATS computer diagnostics to fault isolate and test SRUs & LRUs. Other test equipment include AN/PSM-6, VTVM, and scope to troubleshoot to the discrete component.

**DESIGN-FOR-REPAIR CONCEPT DEFINITION
FIELD EVALUATION REPORT**

DATE: 4 October 1978

BASE: George AFB (2-4 October 1978)		WEAPON SYSTEM: F-4E	
PERSONNEL CONTACTED:			
Col. Covington	DCM, 35th TFW		
CMS Berg	DCM		
Lt. Col. Grover	CRS Commander		
Capt. Cox	Avionics Maintenance Officer		
CMS Brooks	Avionics Superintendent		
SSGT Horne	NCOIC Photo Equipment Section		
Lt. Hathaway	Maintenance Analysis		
SSGT Walker	Maintenance Analysis		
Mr. D. E. Edwards	Odgen ALC Shop Foreman		
SUBSYSTEM CATEGORY: Reconnaissance		WORK UNIT CODE: 77J00	
SUBSYSTEM NOMENCLATURE: Direct Radar Scope Recording System/Radar Scope Camera System KS-97A			
DESCRIPTION OF WEAPON SYSTEM MISSION:			
<p>The F-4E/35th TFW mission is training, USAF F-4E assigned to the 431st TFTS are used for training pilots and WSO for assignments to USAF units. The F-4Es assigned to the 20th TFTS are owned by West Germany and are used for training German Air Force (GAF) crews.</p>			
DESCRIPTION OF SUBSYSTEM CAPABILITIES:			
<p>The camera photographs back seat radar displays on the radar indicator storage tube. It also records various radar and armament functions on film by corrolator lights in the periscope assembly. Radar search takes one photograph during each azimuth sweep. Acquisition, track, boresight, air-to-ground boresight, or BIT 3, the camera photographs at preset intervals determined by the FPS switch on the EFC (2 to 6 FPS) 16MM Kodak type U film magazine with 50 ft. capacity.</p>			
NUMBER OF LRUs PER SUBSYSTEM: 2 (Radar Recording Camera KD-42A and Periscope LD-70A Camera-Periscope Assembly Exposure Frequency Control LD-69A)			
LRU NOMENCLATURE/PART NUMBER: Camera KD-42A/A05A0104-1, Periscope LD-70A/A05A0105-1 Freq. Control LD-69A/A05A0034-2 Camera-Periscope Assy/A05A0108-1			
WEAPON SYSTEM FLIGHT HOURS PER MONTH: 20		SUBSYSTEM FLIGHT HOURS PER MONTH: 20	
SUBSYSTEM GROUND OPERATING TIME PER FLIGHT HOUR: 0.016		EVALUATOR: Jim Green Mike Cochran	

INSPECTION REQUIREMENTS (-6):

600 Hr. Insp: Remove camera-periscope assy. and control unit. Clean, inspect and lubricate system per T.O. 10A1-4-15-32. Install camera system and check per T.O. 1F-4E-2-29.

DESCRIPTION OF SUBSYSTEM DESIGN CHARACTERISTICS FOR MAINTENANCE:

BIT on the ECP. Actuation of the BIT switch will operate the camera and the seven correlator lights in the periscope will illuminate. Film Remaining light indicates preset amount of film remaining, door open with magazine in, or magazine not installed. The system consists of two LRUs (camera-periscope and EFC). Each can be removed from the aircraft after disconnecting one connector and removing either 6 or 4 screws.

DESCRIPTION OF SPECIAL MAINTENANCE AIDS OR LOCAL MODIFICATIONS:

None

MAINTENANCE CONCEPT - DESIGN:

Organizational maintenance on the camera set is limited to checking operation of the system, isolating a failure to the EFC or the camera-periscope and replacement of these items. All items are "I" level repairable.

OPERATIONAL ENVIRONMENT

Tactical fighter/bomber deploys using the bare base concept.

Operational concepts for tactical air forces requires a high degree of flexibility and mobility to attain proficiency in tactical operations. This capability must be established in the following areas:

- o Quick-reactions deployment and employment anywhere in the world under any combat conditions
- o Primary employment in limited war and special warfare operations
- o Normal employment as a component of a joint force
- o Operations of extended duration using a wide selection of weapons
- o Economical operation under any combat situation
- o Rapid transition from one type of warfare to another
- o Establish force increments of varying size and type for specialized missions

At a Bare Base deployment site the environment is identified by austere facilities, unfamiliar and severe climatic conditions, the increased tempo of operations, and personal emotional and physical stress.

(See continuation page)

MAINTENANCE ENVIRONMENT

The tactical fighter squadron is organized and manned for organizational and field maintenance capability. Organizational level maintenance includes inspection, servicing, fault isolation, removal and replacement of components and system calibration. Servicing tasks encompass the loading and unloading of munitions. Field maintenance provides intermediate maintenance capability and is organized and capable of supporting the tactical squadrons. This capability is the same at the deployed base as at the home base and includes repair and testing of engines; local manufacture of parts; testing, calibration and repair of aircraft and aerospace ground equipment, assemblies and components; and inspection and repair which is beyond the capability of organizational level maintenance. In addition, a complete precision measurement equipment laboratory is available to support maintenance functions at home base and deployments to a Bare Base.

By necessity, a large portion of required maintenance, e.g., unscheduled/scheduled, must be accomplished during the hours of darkness in preparation for the next mission (sortie). Maintenance capability must exist regardless of the hour of the day or weather conditions. The flightline maintenance environment is far from ideal. Flightline maintenance personnel are subjected to distractions of jet

(See continuation page)

NATURAL ENVIRONMENT

Climatic conditions can range throughout the full spectrum of weather. During Bare Base operations, hostility requirements dictate that all operations will be conducted on a 24-hour day, 7-day week basis. The maintenance environment is subjected to extreme climatic variances due to rapid response deployment requirements. The amount of variance encountered relates directly to the degree of maintenance efficiency which may be expected and subsequently the effectiveness of the fighting unit.

Flight-line maintenance activities expose both men and equipment to the mercy of the elements. Maintenance is performed around the clock and personnel are exposed to further distraction from high noise levels. Shop maintenance conditions exist generating a continuing programmed requirement for 24 hour shift work.

(See continuation page)

DESIGN-FOR-REPAIR CONCEPT DEFINITION

CONTINUATION PAGE

DATE: 4 October 1978

OPERATIONAL ENVIRONMENT

These bases range in capability from advanced terminals such as Orly in Paris on one extreme to narrow, weed-grown strips in Chad in Africa on the other. In addition, there are numerous other bases, where facilities for personnel support and general housekeeping are adequate, but the maintenance equipment is not equal to current advanced aircraft weapons systems.

MAINTENANCE ENVIRONMENT

engines in operation, taxiing aircraft and jet blast. Use of handbooks and schematics normally associated with flightline maintenance is externally difficult for the reasons stated. Shop maintenance (intermediate maintenance) operations are more extensive than flightline maintenance functions. Even though work requirements may generate a need for around the clock operations and facilities are crowded, work is normally performed in some type of shelter, building, etc.

NATURAL ENVIRONMENT

Climatic conditions of high humidity indirectly affect performance of electronic equipment to some degree. Extreme temperature has a greater effect on maintenance personnel than on equipment. Extremes in temperature and humidity are directly related to the magnitude of the problems encountered and the solutions required to support immediate flight operations.

DESIGN-FOR-REPAIR CONCEPT DEFINITION

ACCESSIBILITY OF AVIONICS

DATE: 4 October 1978

GENERAL DESCRIPTION:

Camera-periscope assembly mounts on front of radar scope in back seat. The camera connector plugs in under the left side of the instrument panel. The mounting bolts are visible and accessible for removal. The connector is also visible for removal. No other units must be removed to remove this assembly. The exposure frequency control mounts in the front of the right console. The front of the unit is recessible for loosening of four fasteners. The unit connector is accessible for disconnecting after the unit is lifted out of the console.

QUANTITATIVE VALUES:

LRU Replacment:

- 1) Camera-Periscope Assy - 6 bolts and one connector (4 Min. Est.)
- 2) EFC - 4 quarter turn fasteners - one connector (3 Min. Est.)

DESCRIBE SUBSYSTEM REMOVAL:

Camera-Periscope Assembly:

- 1) Disconnect camera connector
- 2) Remove four radar indicator handle retaining bolts and two handles
- 3) Remove two periscope mounting bolts and remove camera-periscope assembly

Exposure Frequency Control:

- 1) Loosen four fasteners on face of EFC
- 2) Lift unit and disconnect electrical connector
- 3) Remove EFC

DESIGN-FOR-REPAIR CONCEPT DEFINITION

AGE OF SYSTEM & TECHNOLOGY

DATE: 4 October 1978

GENERAL DESCRIPTION:

The direct radar scope recording system was build and installed on such aircraft as the F-4C, F-4D, F-4E and other F-4 models delivered to NATO countries. The design reflects technology in excess of 10 years old.

TYPE OF COMPONENTS USED:

- (1) EFC was solid state (discrete components)
- (2) No hybrids utilized

TYPE OF WIRING AND INTERFACE USED:

- 1) Boards/components hardwired to chassis
- 2) Single electrical connector on each unit for connection to aircraft system.
- 3) Camera connector on harness hardwired to unit
- 4) EFC connector on back of unit

SYSTEM DESIGN APPROACH (ANALOG, DIGITAL, SOFTWARE, ETC.):

- 1) Analog signal processing

DESIGN-FOR-REPAIR CONCEPT DEFINITION

DEBRIEFING

DATE: 4 October 1978

DESCRIPTION OF THE DEBRIEFING FUNCTION:

The debriefing function operates independently from the camera shop. The direct radar scope recording system status is determined by the aircrew at time of weapon system debriefing through appropriate entry into the aircraft forms.

DESCRIBE THE DEBRIEFING PROCEDURE:

1. Aircrew determines operational status.
2. Aircrew writes the scope camera discrepancies in aircraft forms.
3. Debriefing function relay system status to job control/expeditor truck.
4. Job control notifies camera shop on non-functioning system.

DESCRIBE DATA FLOW AND RECORDS:

Camera shop completes AFTO 349 & 350 forms on maintenance action and these forms enter the AFM66-1 data collection system

DESIGN-FOR-REPAIR CONCEPT DEFINITION

DEPOT SUPPORT

DATE: 4 October 1978

DESCRIPTION OF DEPOT SUPPORT SCOPE:

Depot support for the direct radar recording system consists of piece part, SRU, and LRU repair beyond the capability of the "I" level shops.

DEPOT SUPPORT EFFECTIVENESS:

This camera system is adequately supported with spares to support the operational mission.

COMMENTS:

None

DESIGN-FOR-REPAIR CONCEPT DEFINITION

(PRE, IN, POST) -FLIGHT INSPECTION

DATE: 4 October 1978

DESCRIPTION OF THE INSPECTIONS:

- 1) Aircrew loads film-pack into camera.
- 2) Radar is timed-in and BIT test button is pressed on Exposure Frequency Control Panel.
- 3) Seven correlator lights come on and film advances (as determined by feeling side of camera for vibration).

FREQUENCY OF INSPECTIONS:

Each flight

PURPOSE OF INSPECTIONS:

Verify normal camera operation and accomplish maintenance as required.

COMMENTS:

Camera-periscope assembly and exposure frequency control are pulled out of the aircraft and checked in the shop.

DESIGN-FOR-REPAIR CONCEPT DEFINITION

LEVEL OF BASE REPAIR

DATE: 4 October 1978

DESCRIPTION OF ORGANIZATIONAL REPAIR:

1. UNSCHEDULED:

Functional checkout of system and remove/replace defective unit.

2. SCHEDULED:

600 hour phase inspection

DESCRIPTION OF INTERMEDIATE REPAIR:

1. UNSCHEDULED:

Functional checkout of units in shop and remove/replace defective component

2. SCHEDULED:

600 hour phase inspection

DESCRIPTION OF DEPOT REPAIR:

1. UNSCHEDULED:

- a. Repair of SRU
- b. Repair of LRU beyond the capability of intermediate maintenance

The depot uses GPATS to fault isolate and test SRUs and LRUs. Also, a collimator is used to verify optical resolution.

2. SCHEDULED:

None

DESIGN-FOR-REPAIR CONCEPT DEFINITION

MAINTAINABILITY CHARACTERISTICS OF EQUIPMENT DESIGN

DATE: 4 October 1978

GENERAL DESCRIPTION OF SUBSYSTEM FEATURES:

- 1) BIT Switch (located on EFC) - runs film and activates correlator lights.
- 2) Motor Power Light - indicates power application to motor
- 3) Film Remaining Light - indicates: 0-15 feet film remaining, door open with magazine installed, or magazine not installed.
- 4) Correlator lights in periscope rather than storage tube assemble-simplifies field repair.

QUANTITATIVE VALUES:

- | | | |
|---|---|---|
| (1) MTBF - 565 Hours | (2) MTBM - 140.2 Hours @ Organizational Level | (3) MMH/FH - 0.03 Combined Organizational & Intermediate Levels |
| (4) MTTR - 2.0 Hours Organizational Level
1.9 Hours Intermediate Level | (5) MTBD - 342 Hours @ Organizational Level | |

All values based on AFM 66-1 data.

QUALITATIVE FEATURES:

- System -
- 1) 2 LRUs simplify fault-isolation in aircraft
 - 2) LRUs are easy to replace
 - 3) Electronics/electro-mechanical assemblies very reliable
 - 4) Film packs loaded by Kodak and processed by Photo Shop
 - 5) Titler provided in periscope to positively ID film
 - 6) Aircrews install/remove/checkout film packs and camera system
 - 7) Test equipment/fixtures/tools provided in "I" shop for complete repair
 - 8) EFCP has components mounted on two hardwired boards with test points

COMMENTS:

- 1) Camera harness damage most prevalent problem - Result of radar scope removal without disconnecting camera cable connector (not visible without looking under instrument panel). Cable is held replaceable.

DESIGN-FOR-REPAIR CONCEPT DEFINITION

**MAINTENANCE DATA COLLECTION DOCUMENTATION
& FEEDBACK SYSTEM**

DATE: 4 October 1978

GENERAL DESCRIPTION:

The maintenance data collections is in accordance with AFM 66-1.

IMPLEMENTED METHODS:

Data is collected on the AFTO 349 or 350 forms. The data are keypunched from these forms and process to the applicable ALC maintenance data activity.

METHOD(S) EFFECTIVENESS:

The system is effective, but because the camera system is highly reliable and has a low utilization rate, this system is not one that needs constant review and analysis. As such, the feedback of information is not provided to the shop from the maintenance analysis function of the Deputy Commander for Maintenance (DCM).

COMMENTS:

If the camera shop needed the information to help define maintenance problem areas, the information would be analyzed and provided to the maintenance activity.

DESIGN-FOR-REPAIR CONCEPT DEFINITION

MAINTENANCE ORGANIZATION

DATE: 4 October 1978

GENERAL DESCRIPTION:

The maintenance organization is in accordance with AFR 66-5.

MAINTENANCE ORGANIZATION FLOW CHART:

The camera shop activity is part of the component repair squadron and supports both organizational and intermediate maintenance requirements.
(See attached charts).

DESIGN-FOR-REPAIR CONCEPT DEFINITION

CONTINUATION PAGE

DATE: 4 October 1978

MAINTENANCE ORGANIZATION FLOW CHART:

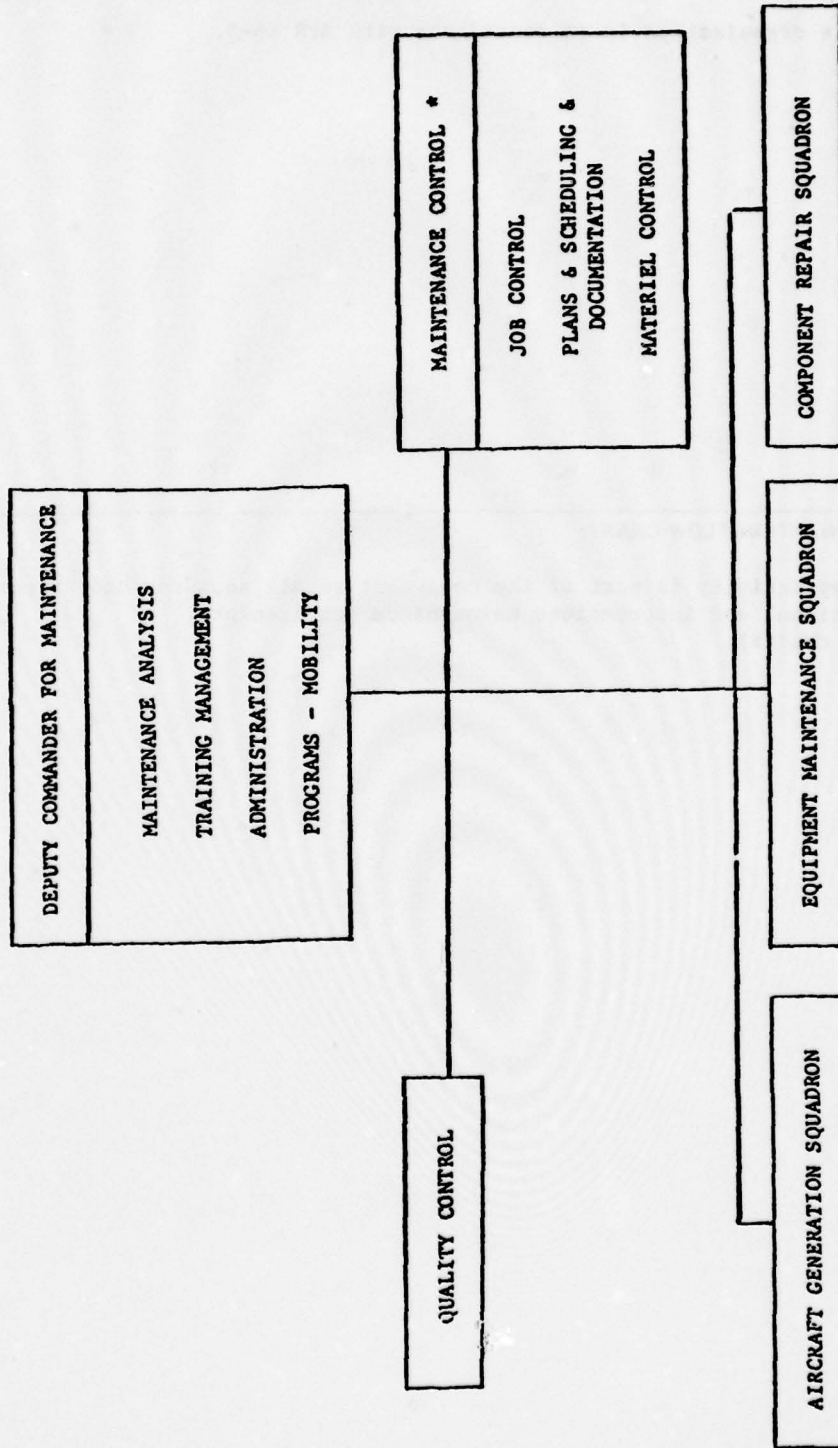

* May include Munitions Control

DESIGN-FOR-REPAIR CONCEPT DEFINITION

CONTINUATION PAGE

DATE: 4 Oct. 1978

MAINTENANCE ORGANIZATION FLOW CHART:

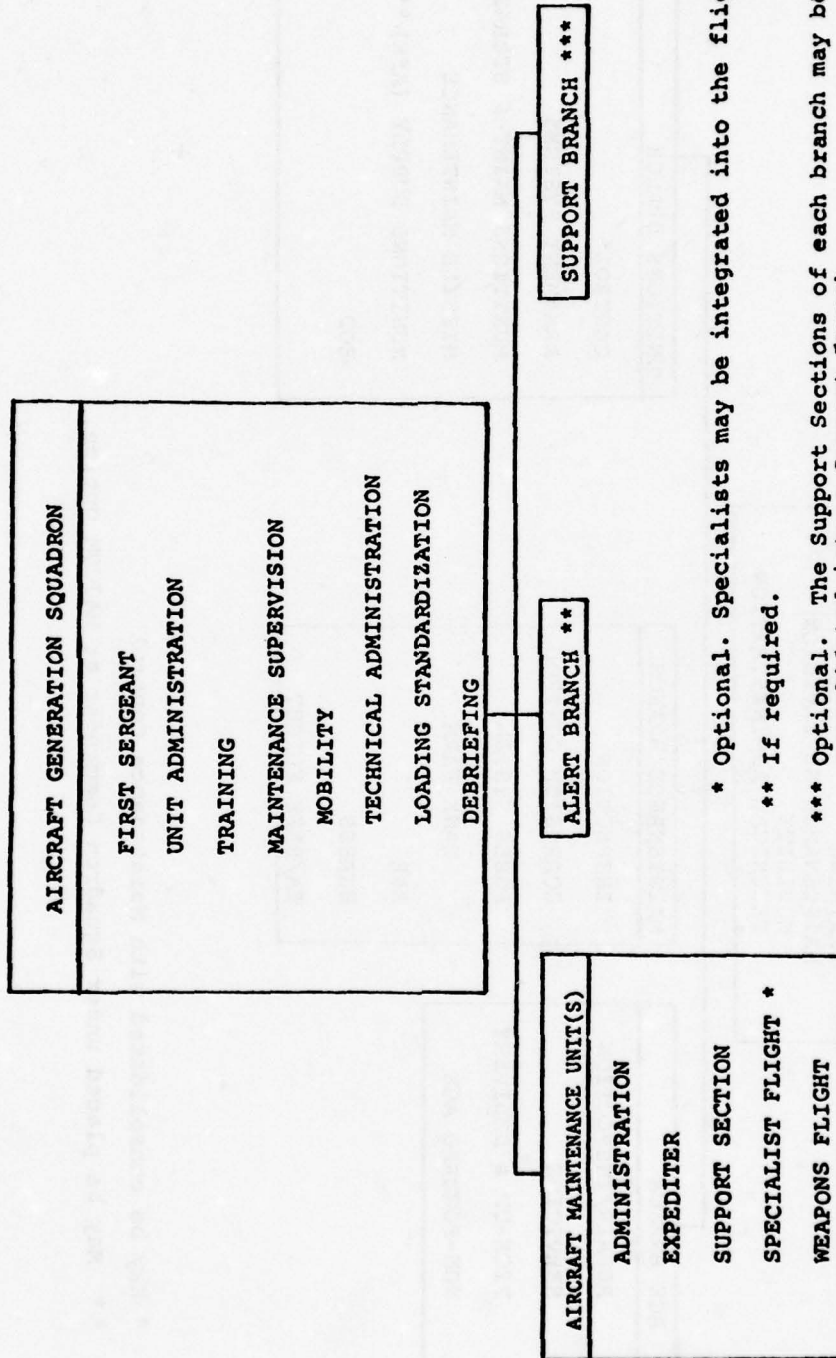

* Optional. Specialists may be integrated into the flights.
 ** If required.
 *** Optional. The Support Sections of each branch may be consolidated into a Support Branch.

DESIGN-FOR-REPAIR CONCEPT DEFINITION

CONTINUATION PAGE

DATE: 4 October 1978

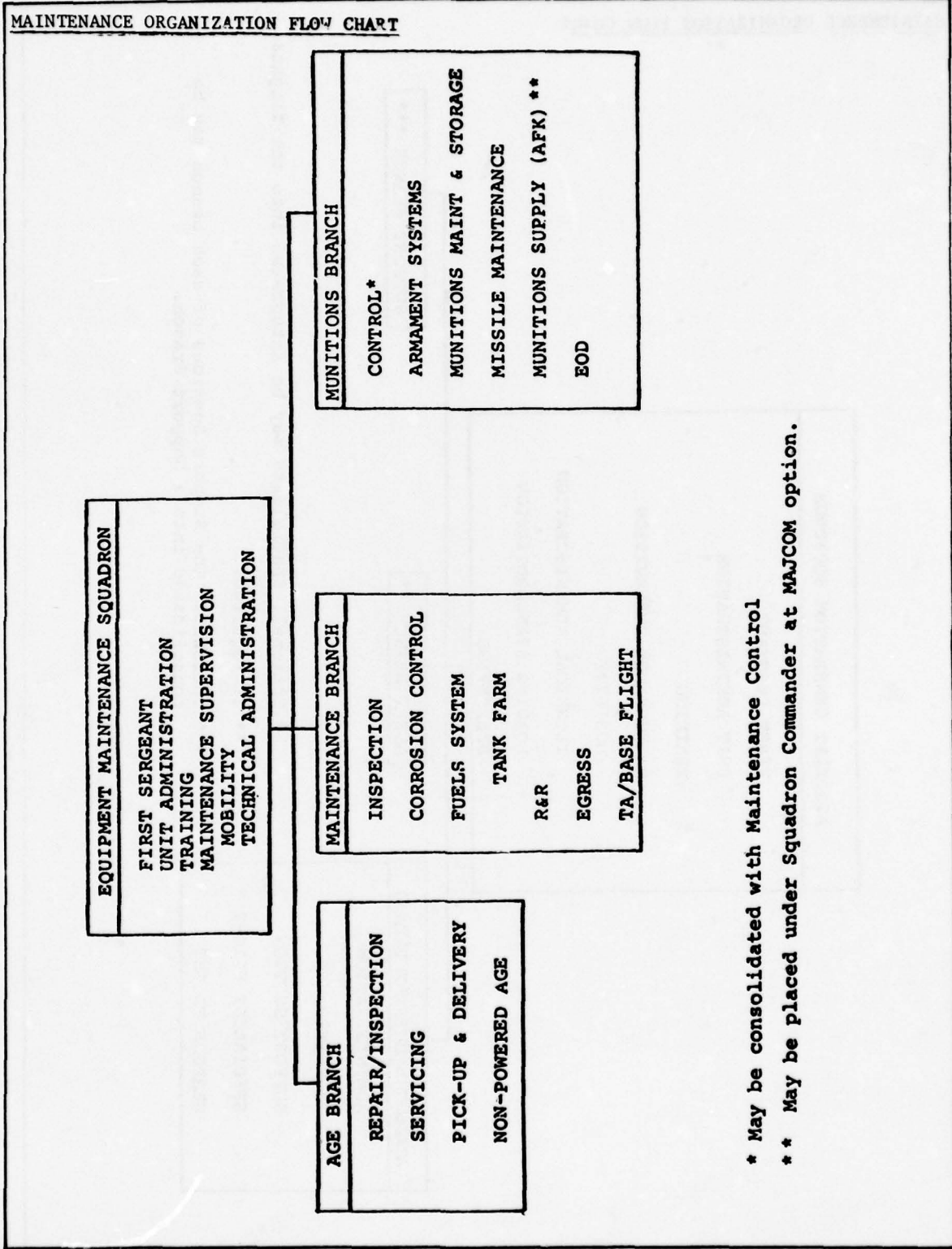

* May be consolidated with Maintenance Control

** May be placed under Squadron Commander at MAJCOM option.

DESIGN-FOR-REPAIR CONCEPT DEFINITION

CONTINUATION PAGE

DATE: 4 October 1978

MAINTENANCE ORGANIZATION FLOW CHART

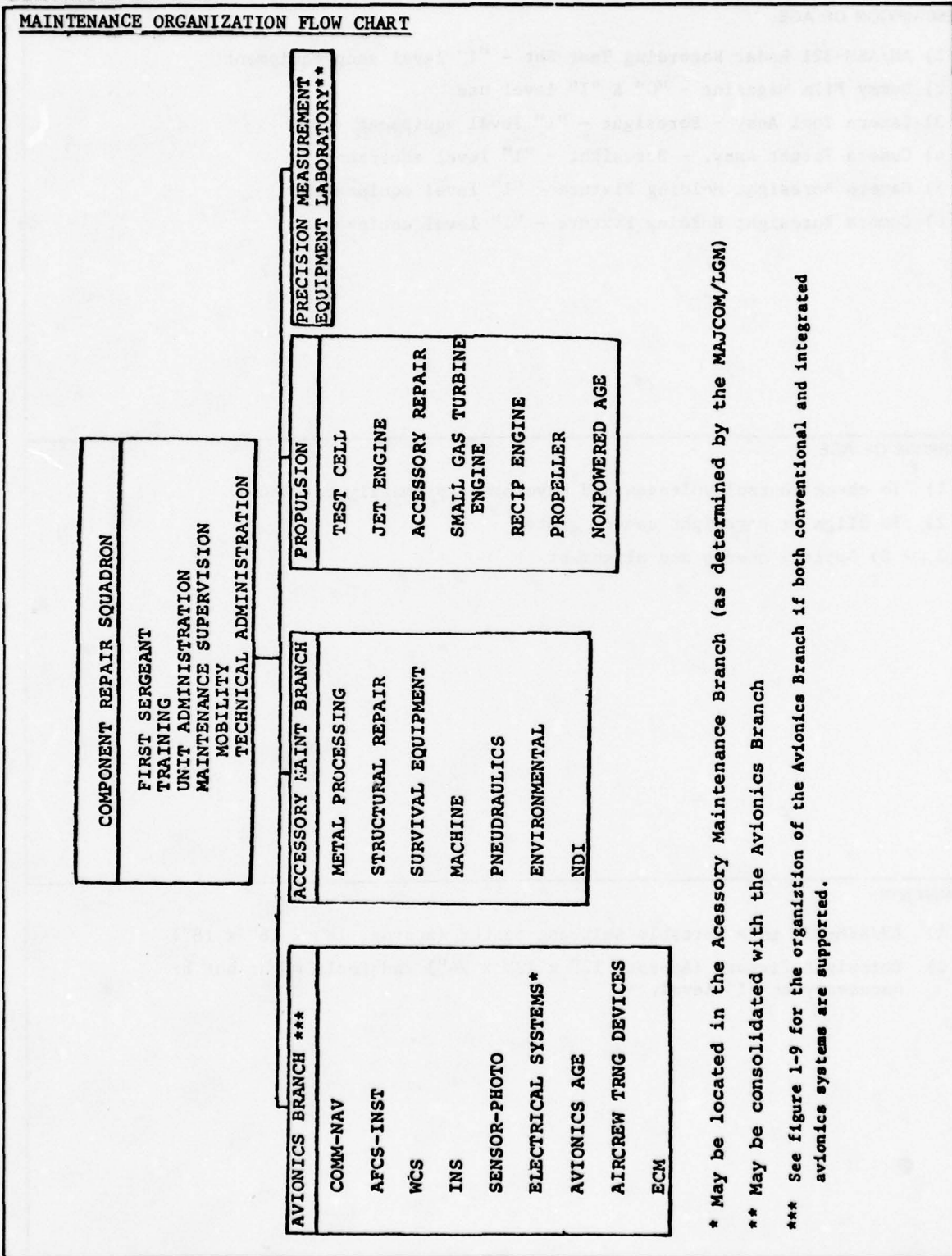

* May be located in the Accessory Maintenance Branch (as determined by the MAJCOM/LGM)

** May be consolidated with the Avionics Branch

*** See figure 1-9 for the organization of the Avionics Branch if both conventional and integrated avionics systems are supported.

DESIGN-FOR-REPAIR CONCEPT DEFINITION

ORGANIZATIONAL LEVEL AGE

DATE: 4 October 1978

DESCRIPTION OF AGE:

- 1) AN/ASM-321 Radar Recording Test Set - "I" level shop equipment
- 2) Dummy Film Magazine - "O" & "I" level use
- 3) Camera Tool Assy - Boresight - "I" level equipment
- 4) Camera Target Assy. - Boresight - "I" level equipment
- 5) Camera Boresight Holding Fixture - "I" level equipment
- 6) Camera Boresight Holding Fixture - "I" level equipment

PURPOSE OF AGE:

- 1) To check control voltages and waveforms, primarily for EFC
- 2) To align or boresight camera system
- 3 - 5) Optical checks and alignment

COMMENTS:

- 1) AN/ASM-321 is a portable suitcase tester (approx. 18" x 18" x 18")
- 2) Boresight fixture (Approx. 12" x 12" x 24") and tools might not be necessary at "I" level.

DESIGN-FOR-REPAIR CONCEPT DEFINITION

PREVENTIVE MAINTENANCE

DATE: 4 October 1978

GENERAL DESCRIPTION:

600 Hour Inspection:

- 1) Remove system from aircraft
- 2) Checkout system in shop
- 3) Accomplish repairs as required
- 4) Install equipment in aircraft
- 5) Perform checkout of system in aircraft

PREVENTIVE MAINTENANCE REQUIREMENT SOURCE:

T.O. 1F-4C-6

COMMENTS:

Cleaning is limited to wiping lenses with lense cloth.

No lubrication is required.

DESIGN-FOR-REPAIR CONCEPT DEFINITION

TECHNICAL ORDERS

DATE: 4 October 1978

DESCRIPTION OF TECH DATA REQUIREMENTS:

T.O. 1F-4E-2-29

Maintenance Instrument, Photographic Systems, F-4E, Dec. 71 basic, Chg. 12, Mar. 77

T.O. 10A1-4-15-32

Technical Manual, Field Maintenance Instructions, Data Recording Camera Set KS-97A, Camera-Periscope Assy, Still Picture Camera KD-42A, Periscope LD-70A. Exposure Frequency Control LD-69A, Mar. 71 basic, Chg. 9, Dec. 77.

DESCRIPTION OF TECH DATA FIELD DISCREPANCIES:

Technical data for the direct radar scope recording system is adequate except for minor errors in text.

DESIGN-FOR-REPAIR CONCEPT DEFINITION

TRAINING & PERSONNEL SKILLS LEVEL

DATE: 4 October 1978

DESCRIPTION OF SKILLS REQUIREMENTS:

The authorized skill requirements, while not available, were indicated as being adequate to meet the maintenance concept. Experience on this system is the biggest asset in affecting an effective repair.

DESCRIPTION OF ASSIGNED SKILLS:

10 authorized

9 assigned

The shop manning is adequate to meet mission requirements.

GENERAL COMMENTS:

1. 4.5 months in technical school
2. 6 to 8 months OJT

DESIGN-FOR-REPAIR CONCEPT DEFINITION

TROUBLESHOOTING METHODS

DATE: 4 October 1978

DESCRIPTION OF ORGANIZATIONAL TROUBLESHOOTING METHODS:

- 1) Functional check on aircraft to duplicate problem.
- 2) Remove suspected unit for shop check.
- 3) Trouble-shoot aircraft circuits if units check good.

DESCRIPTION OF INTERMEDIATE TROUBLESHOOTING METHODS:

- 1) Check units on AN/ASM-312 test set to verify problem.
- 2) Remove/replace defective components - fault isolation using common test instruments, special boresight fixtures and tools, plus the AN/ASM-321 test set.

DESCRIPTION OF DEPOT TROUBLESHOOTING METHODS:

The depot uses the GPATS computer diagnostics to fault isolate and test SRUs and LRUs. Other test equipment include AN/PSM-6, VTVM, and scope to trouble-shoot to the discrete component.

**DESIGN-FOR-REPAIR CONCEPT DEFINITION
FIELD EVALUATION REPORT**

DATE: 16 October 1978

BASE: Langley AFB, Virginia (9-12 October 1978)		WEAPON SYSTEM: F-15	
PERSONNEL CONTACTED: Col. Laird, DCM 1st TFW CMC Phillips SMSGT W. Sawyer *MSGT Anderson *Sgt. Borysewich Mr. C. M. Arthur WR-ALC/MAIPFC Mr. D. C. Feeney WR-ALC/MAIEF Mr. T. E. Woods WR-ALC/MAITC *Mr. H. Pritchett WR-ALC, Maintenance *Mr. P. Fincher WR-ALC, Maintenance *AN/AWG-20 maintenance			
SUBSYSTEM CATEGORY: WEAPONS DELIVERY		WORK UNIT CODE: 75M00	
SUBSYSTEM NOMENCLATURE: ARMAMENT CONTROL AN/AWG-20			
DESCRIPTION OF WEAPON SYSTEM MISSION: The mission of the weapons system is as a tactical fighter/bomber to deliver munitions on designated ground targets and missiles/rapid-fire general ordnance during air combat situations.			
DESCRIPTION OF SUBSYSTEM CAPABILITIES: The armament control set performs the necessary functions for operation of the missile control system and the bombing control system. The AN/AWG-20 ACS consists of the armament control panel (ACP) and the converter-programmer (C-P). The ACP contains the controls, indicators and related circuitry to provide the pilot with weapon/store status information and enable him to operate the armament system. The C-P provides an interface between the ACP and the armament system's central computer, the C-P furnishes the power switching functions required in the selection, arming, and launch/release of air-to-air and air-to-ground stores. Circuitry required for operation of the aircraft's internal cannon and the supplying of ACS logic and bias voltages are contained in the C-P. The AN/AWG-20 armament control system is a repackaged configuration of the AN/AWG-17 which consists of three LRUs.			
NUMBER OF LRUs PER SUBSYSTEM:		Two	
LRU NOMENCLATURE/PART NUMBER:		Armament Control Panel: P/N 11078-10 Converter-Programmer: P/N 11077-10	
WEAPON SYSTEM FLIGHT HOURS PER MONTH: 20.0		SUBSYSTEM FLIGHT HOURS PER MONTH: 20.0	
SUBSYSTEM GROUND OPERATING TIME PER FLIGHT HOUR: 1.33		EVALUATOR: Gerkin King	

INSPECTION REQUIREMENTS (-6):

300 hr. phase inspection using AN/AWM-72

- Single stores release and jettison system
- Multiple stores release and jettison system at pylon disconnect
- Pylon jettison system

DESCRIPTION OF SUBSYSTEM DESIGN CHARACTERISTICS FOR MAINTENANCE:

The AN/AWG-20 ACS has an automatic BIT and initiated BIT circuit. The automatic BIT monitors components in the ACP and C-P whenever the ACS is turned on. Reports in-flight failures and continuously performs self-test.

DESCRIPTION OF SPECIAL MAINTENANCE AIDS OR LOCAL MODIFICATIONS:

None

MAINTENANCE CONCEPT - DESIGN:Organizational

- BIT
- Remove/replace LRU

Intermediate

- LRU Failure verification using the AN/AWM-72 armament system test set (ASTS).
- Fault Isolation
- SRA R/R

Depot

- Fault isolation
- Component repair
- Bit/piece
- Test, align, calibrate

OPERATIONAL ENVIRONMENT

Tactical fighter/bomber deploys using the Bare Base Concept.

Operational concepts for tactical air forces requires a high degree of flexibility and mobility to attain proficiency in tactical operations. This capability must be established in the following areas:

- Quick-reactions deployment and employment anywhere in the world under any combat conditions
- Primary employment in limited war and special warfare operations
- Normal employment as a component of a joint force
- Operations of extended duration using a wide selection of weapons
- Economical operation under any combat situation
- Rapid transition from one type of warfare to another
- Establish force increments of varying size and type for specialized missions

MAINTENANCE ENVIRONMENT

The tactical fighter squadron is organized and manned for organizational and field maintenance capability. Organizational level maintenance includes inspection, servicing, fault isolation, removal and replacement of components and system calibration. Servicing tasks encompass the loading and unloading of munitions. Field maintenance provides intermediate maintenance capability and is organized and capable of supporting the tactical squadrons. This capability is the same at the deployed base as at the home base and includes repair and testing of engines; local manufacture of parts; testing, calibration and repair of aircraft and aerospace ground equipment, assemblies and components; and inspection and repair which is beyond the capability of organizational level maintenance. In addition, a complete precision measurement equipment laboratory is available to support maintenance functions at home base and deployments to a Bare Base.

By necessity, a large portion of required maintenance, e.g., unscheduled/scheduled, must be accomplished during the hours of darkness in preparation for the next mission (sortie). Maintenance capability must exist regardless of the hour of the day or weather conditions. The flightline maintenance environment is far from ideal. Flightline maintenance personnel are subjected

NATURAL ENVIRONMENT

Climatic conditions can range throughout the full spectrum of weather. During Bare Base operations, hostility requirements dictate that all operations will be conducted on a 24-hour day, 7-day week basis. The maintenance environment is subjected to extreme climatic variances due to rapid response deployment requirements. The amount of variance encountered relates directly to the degree of maintenance efficiency which may be expected and subsequently the effectiveness of the fighting unit.

Flightline maintenance activities expose both men and equipment to the mercy of the elements. Maintenance is performed around the clock and personnel are exposed to further distraction from high noise levels. Shop maintenance conditions are superior to those experienced on the flightline; however, crowded conditions exist generating a continuing programmed requirement for 24-hour shift work.

DESIGN-FOR-REPAIR CONCEPT DEFINITION

CONTINUATION PAGE

DATE: 16 October 1978

OPERATIONAL ENVIRONMENT (Continued)

At a Bare Base deployment site the environment is identified by austere facilities, unfamiliar and severe climatic conditions, the increased tempo of operations, and personal emotional and physical stress. These bases range in capability from advanced terminals such as Orly in Paris on one extreme to narrow, weed-grown strips in Chad in Africa on the other. In addition, there are numerous other bases, where facilities for personnel support and general housekeeping are adequate, but the maintenance equipment is not equal to current advanced aircraft weapons systems.

MAINTENANCE ENVIRONMENT (Continued)

to distractions of jet engines in operation, taxiing aircraft and jet blast. Use of handbooks and schematics normally associated with flightline maintenance is externally difficult for the reasons stated. Shop maintenance (intermediate maintenance) operations are more extensive than flightline maintenance functions. Even though work requirements may generate a need for around the clock operations and facilities are crowded, work is normally performed in some type of shelter, building, etc.

NATURAL ENVIRONMENT (Continued)

Climatic conditions of high humidity indirectly affect performance of electronic equipment to some degree. Extreme temperature has a greater effect on maintenance personnel than on equipment. Extremes in temperature and humidity are directly related to the magnitude of the problems encountered and the solutions required to support immediate flight operations.

DESIGN-FOR-REPAIR CONCEPT DEFINITION

ACCESSIBILITY OF AVIONICS

DATE: 18 October 1978

GENERAL DESCRIPTION:

- Converter-Programmer is located in forward left avionics bay (Door 6L). No accessibility problems.
- Armament Control Panel is mounted in left side of pilots forward instrument console within cockpit. Some difficulty encountered in removal/replacement due to limited play of ACP wire bundle at rear of ACP.

QUANTITATIVE VALUES:

C-P: 3-4 minutes to remove or replace.

DESCRIBE SUBSYSTEM REMOVAL:

- C-P: Remove seven quick disconnect cable plugs - release two hinged latches - slide C-P out of compartment.
- ACP: Remove five 'Phillips' type brass screws, pull ACP away from instrument console to provide clearance to wiring cable - remove cable - remove ACP.

DESIGN-FOR-REPAIR CONCEPT DEFINITION

AGE OF SYSTEM & TECHNOLOGY

DATE: 18 October 1978

GENERAL DESCRIPTION:

The AN/AWG-20 armament control system was built and installed in the F-15 weapon system. The design reflects technology of the mid-to late 1960. The AN/AWG-20 was installed in the airframe around 1973 using a system integration approach. This armament system is similar to the system designed for the F-111D weapon system.

TYPE OF COMPONENTS USED:

Integrated circuits
Hybrids
Microelectronic circuitry
PCC
Wire wrap and soldered connections

TYPE OF WIRING AND INTERFACE USED:

Interface - quick disconnect connectors for wiring and waveguides
Wiring - PCC, wiring bundles

SYSTEM DESIGN APPROACH (ANALOG, DIGITAL, SOFTWARE, ETC.):

Digital design - pre-programmed and controlled from central computer.

DESIGN-FOR-REPAIR CONCEPT DEFINITION

DEBRIEFING

DATE: 17 October 1978

DESCRIPTION OF THE DEBRIEFING FUNCTION:

Debriefings are conducted following each flight to allow the pilot to provide information regarding performance of the A/C systems during flight and operational evaluation of in-flight events. Maintenance related data are recorded by the debriefer on TAC Form 93 (Debriefing Form). A JCN is assigned each discrepancy and an AFTO 349 is completed.

DESCRIBE THE DEBRIEFING PROCEDURE:

AN/AWG-20 maintenance personnel do not attend debriefing. Discrepancies are reported following the debrief using the AFTO 349.

DESCRIBE DATA FLOW AND RECORDS:

AN/AWG-20 maintenance personnel complete the AFTO 349 and AFTO 350 and this data enters the AFM 66-1 MDCS.

DESIGN-FOR-REPAIR CONCEPT DEFINITION

DEPOT SUPPORT

DATE: 1 November 1978

DESCRIPTION OF DEPOT SUPPORT SCOPE:

Bit/Piece (component) repair of SRUs for all LRUs. LRU (as required) and SRU support for the AN/AWG-20 is at Warner-Robins.

DEPOT SUPPORT EFFECTIVENESS:

Spare support for the AN/AWG-20 is a continuing problem at the LRU level. No particular problems noted in spare support at the depot for bit and piece and SRU although there is about a 15% AWP rate. Increased depot maintenance time due to manual probe requirements has significantly increased pipeline spares requirement for the Converter-Programmer.

COMMENTS:

None

DESIGN-FOR-REPAIR CONCEPT DEFINITION

(PRE, IN, POST) -FLIGHT INSPECTION

DATE: 17 October 1978

DESCRIPTION OF THE INSPECTIONS:

- Pre - ● Remove safety pins
● Perform stray voltage check using AWM-75 (Weapons Firing Circuit Test Set)
- In - None
- Post - ● Install safety pins
● Perform stray voltage check using AWM-75

FREQUENCY OF INSPECTIONS:

Each flight

PURPOSE OF INSPECTIONS:

Ground and flight safety

COMMENTS:

The performance of these inspections for each flight is contingent on having a store installed on any of the stores stations.

DESIGN-FOR-REPAIR CONCEPT DEFINITION

LEVEL OF BASE REPAIR

DATE: 18 October 1978

DESCRIPTION OF ORGANIZATIONAL REPAIR:

1. UNSCHEDULED:

- BIT
- Remove/replace LRUs

2. SCHEDULED:

None

DESCRIPTION OF INTERMEDIATE REPAIR:

1. UNSCHEDULED:

Armament - Control Panel: R/R modules
Converter - Programmer: R/R modules

2. SCHEDULED:

None

DESCRIPTION OF DEPOT REPAIR:

1. UNSCHEDULED:

Remove/replace SRUs in LRU.
Repair SRUs to component level.

2. SCHEDULED:

DESIGN-FOR-REPAIR CONCEPT DEFINITION

MAINTAINABILITY CHARACTERISTICS OF EQUIPMENT DESIGN

DATE: 18 October 1978

GENERAL DESCRIPTION OF SUBSYSTEM FEATURES:

Solid state design with BIT. ACP contains 7 plug-in PCCs mounted vertically in spring loaded board retainers on the chassis. Three chassis mounted external electrical connectors protrude through holes located in rear surface of the cover. Six mounting holes in the outer flange of the aluminum housing are provided for installation of unit in the aircraft. C-P has eleven external quick-disconnect connectors mounted on the front panel. Two forced cooling air inlet holes located in back of case and screened vents in the front panel are provided to facilitate the dissipation of heat from thirty-nine chassis mounted plug-in PCCs and the power supply assembly. Two carrying handles which can be pivoted out for use, or down for storage, are mounted on the front panel. Provisions for installation of unit in aircraft include two support hooks located on front side of the base and two mounting pads on back side of base.

QUANTITATIVE VALUES:

- | | | |
|---|---|---|
| (1) MTBF - 580 Hours | (2) MTBM - 27.8 Hours @
Organizational Level | (3) MMH/FH - 0.34 Combined
Organizational & Inter-
mediate Levels |
| (4) MTTR - 4.2 Hours Organizational Level
7.5 Hours Intermediate Level | (5) MTBD - 97 Hours @ Organiza-
tional Level | |

All values based on AFM 66-1 data.

QUALITATIVE FEATURES:

- BIT is good in confirming failures (error presence).

COMMENTS:

- AN/AWG-20 is an updated version of AN/AWG-17. Essentially, the controller and programmer of AWG-17 was repackaged into a single LRU for AWG-20.
- BIT does not resolve faults to LRU.
- BIT circuits fail more frequently than primary functions.
- While the quick-disconnect connectors are an excellent feature, there are problems with wires pulling and breaking at pins.
- Trouble is experienced in replacing pins in connectors. This is due primarily to the poor quality of the pin extractor/insertion tool (plastic or metal).
- Shortage of spare LRUs has resulted in extensive cannibalization.
- Brass screws used to mount ACP to A/C cockpit console strip at the star slots.

DESIGN-FOR-REPAIR CONCEPT DEFINITION

**MAINTENANCE DATA COLLECTION DOCUMENTATION
& FEEDBACK SYSTEM**

DATE: 18 October 1978

GENERAL DESCRIPTION:

The maintenance data collection is in accordance with the procedure of AFR 66-1.

IMPLEMENTED METHODS:

Data is collected on the AFTO Form 349 and forwarded to the base data automation center for computer processing. Preformatted data is sent to AFLC. Local management reports and special study reports are provided at the base level.

METHOD(S) EFFECTIVENESS:

Constant review and analysis is performed.

COMMENTS:

DESIGN-FOR-REPAIR CONCEPT DEFINITION

MAINTENANCE ORGANIZATION

DATE: 1 November 1978

GENERAL DESCRIPTION:

Maintenance organization is in accordance with AFR 66-5.

MAINTENANCE ORGANIZATION FLOW CHART:

The maintenance activities for the AN/AWG-20 are part of the Aircraft Generation Squadron for organizational level maintenance and the Equipment Maintenance Squadron for intermediate level maintenance. See attached charts.

DESIGN-FOR-REPAIR CONCEPT DEFINITION

CONTINUATION PAGE

DATE: 1 November 1978

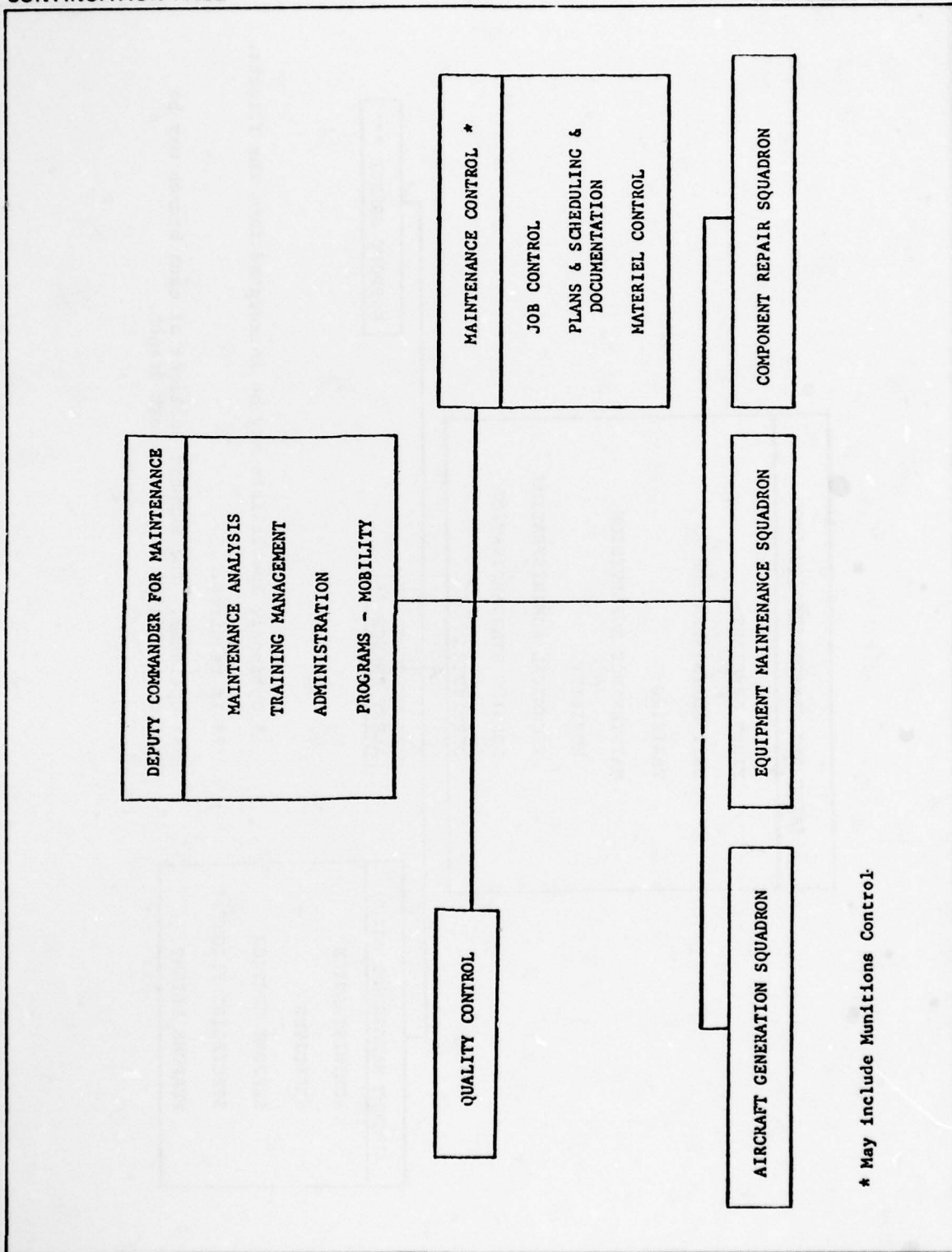

DESIGN-FOR-REPAIR CONCEPT DEFINITION

CONTINUATION PAGE

DATE: 1 November 1978

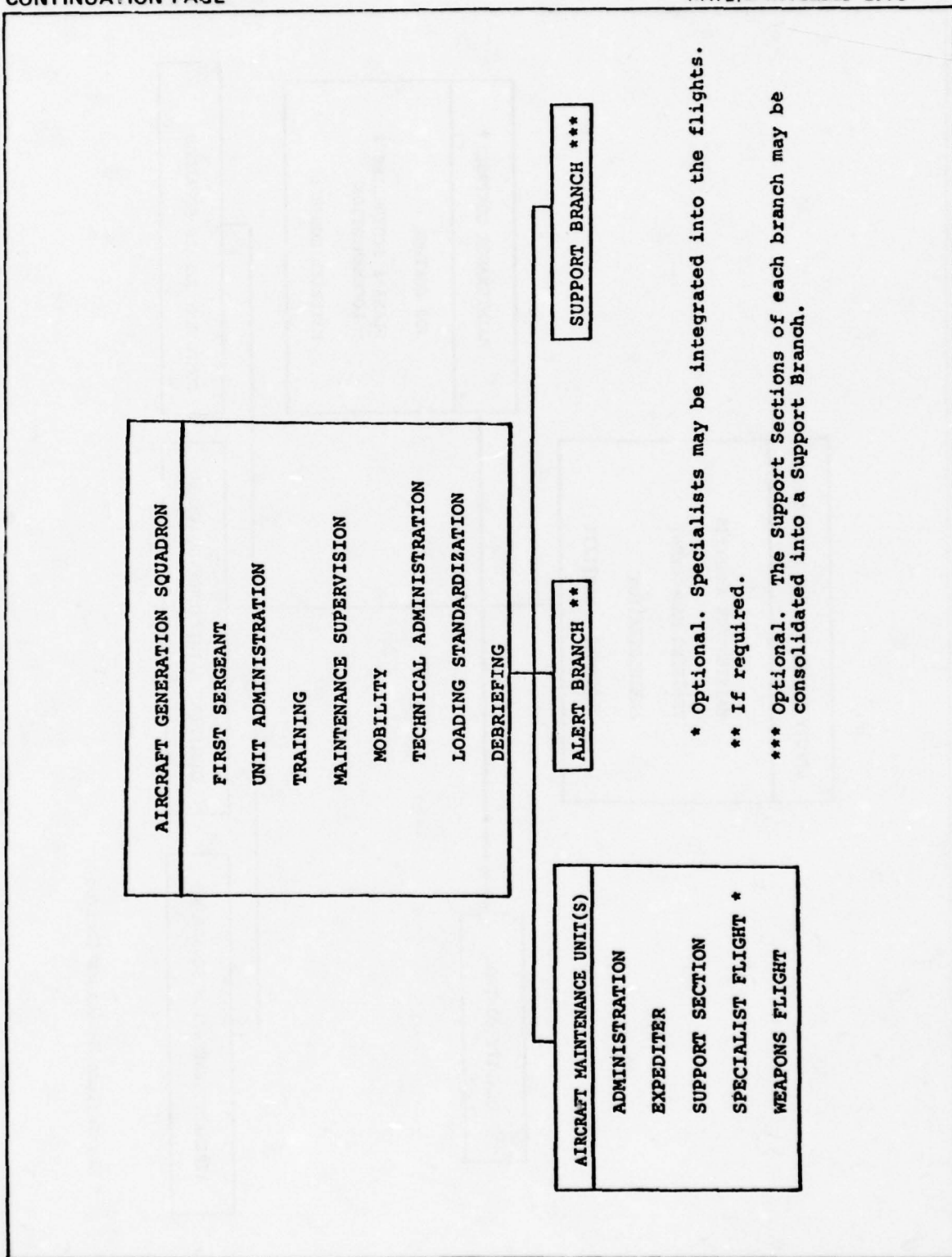

DESIGN-FOR-REPAIR CONCEPT DEFINITION

CONTINUATION PAGE

DATE: 1 November 1978

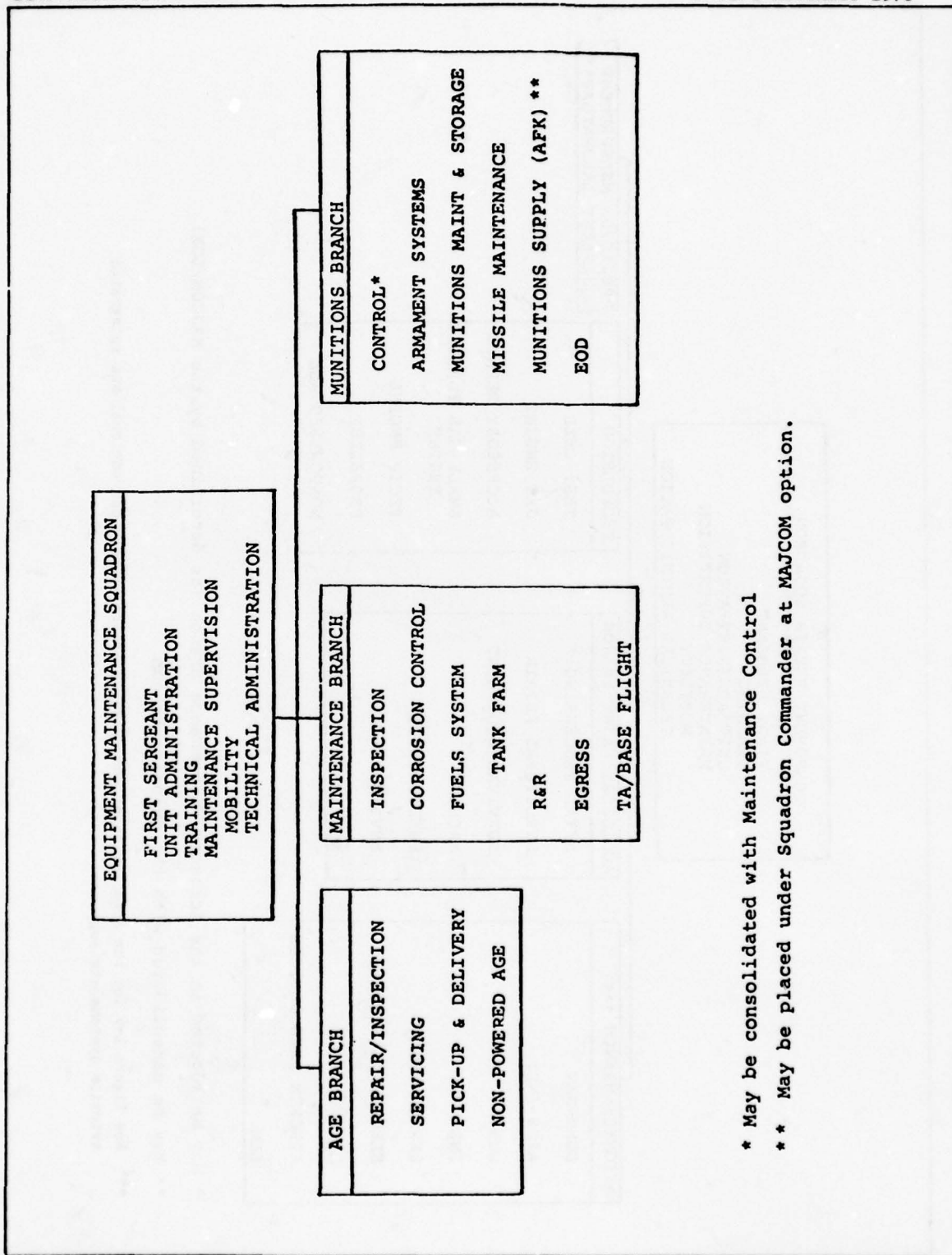

* May be consolidated with Maintenance Control

** May be placed under Squadron Commander at MAJCOM option.

DESIGN-FOR-REPAIR CONCEPT DEFINITION

CONTINUATION PAGE

DATE: 1 November 1978

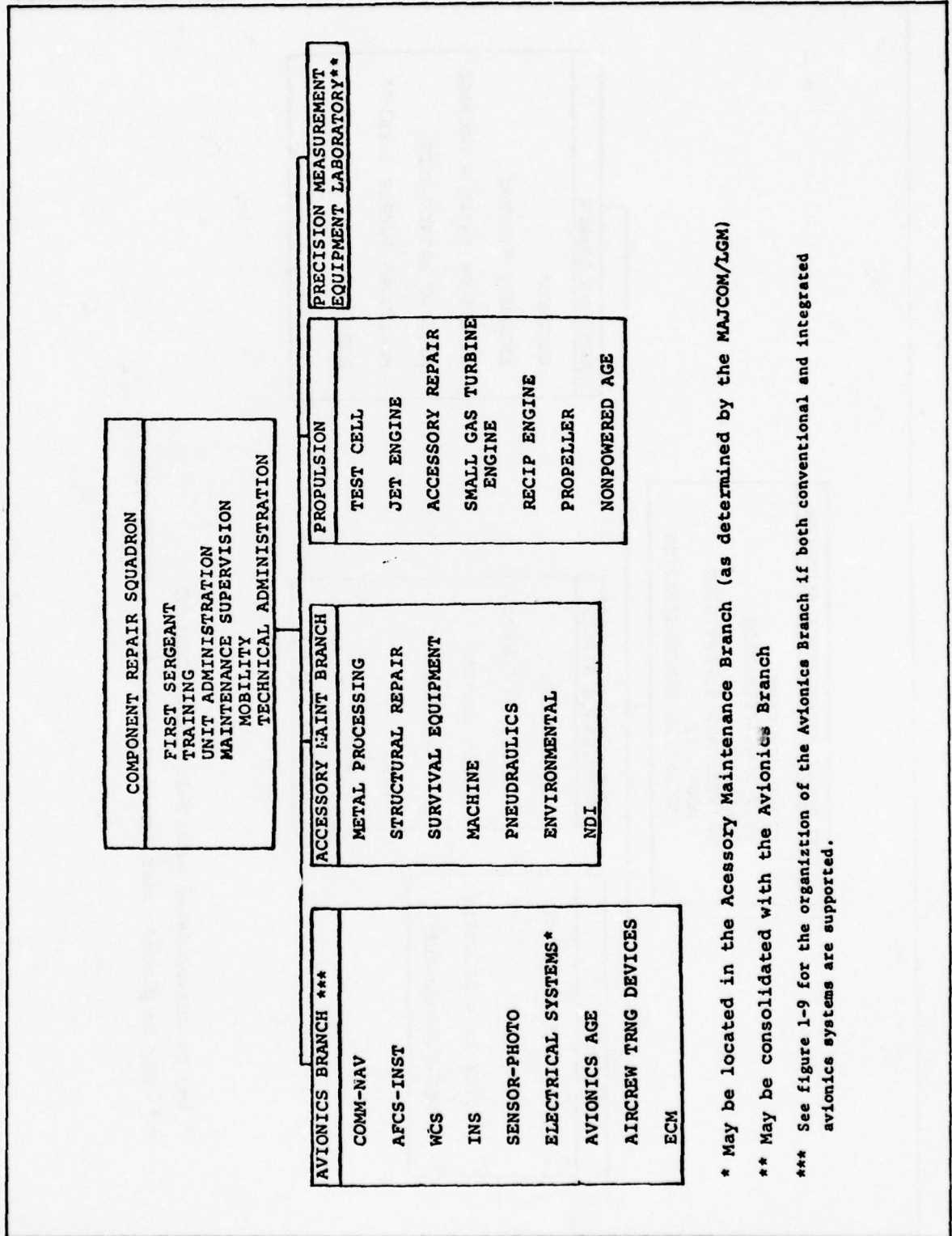

* May be located in the Accessory Maintenance Branch (as determined by the MAJCOM/LGM)

** May be consolidated with the Avionics Branch

*** See figure 1-9 for the organization of the Avionics Branch if both conventional and integrated avionics systems are supported.

DESIGN-FOR-REPAIR CONCEPT DEFINITION

ORGANIZATIONAL LEVEL AGE

DATE: 17 October 1978

DESCRIPTION OF AGE:

- Ground power unit
- Air conditioning unit
- AN/AWM-72 (Armament System Test Set)
- AN/AWM-75 (Weapons Firing Circuit Test Set)

PURPOSE OF AGE:

- Provide auxiliary power and air to operate subsystem.
- AN/AWM-75: Stray voltage check - ground safety.
- AN/AWM-72: Used to check AN/AWG-20 armament system.

COMMENTS:

The AN/AWM-74 (intermediate shop) test set is used to check launchers, racks, and pylons at intermediate maintenance.

Support of the AN/AWM-72 at field level is accomplished by PMEL since this test set has periodic calibration requirements. A similar test set, the AN/AWM-74 has no calibration requirements and as such, is repaired at depot. Armament personnel indicated that PMEL has the capability to repair the AN/AWM-74 but cannot because there is no calibration requirements.

The response time of the power regulator on ground power AGE does not meet the demands required by these test sets.

DESIGN-FOR-REPAIR CONCEPT DEFINITION

PREVENTIVE MAINTENANCE

DATE: 18 October 1978

GENERAL DESCRIPTION:

None

PREVENTIVE MAINTENANCE REQUIREMENT SOURCE:

N/A

COMMENTS:

None

DESIGN-FOR-REPAIR CONCEPT DEFINITION

TECHNICAL ORDERS

DATE: 18 October 1978

DESCRIPTION OF TECH DATA REQUIREMENTS:

ORG: 1F15A-2-13 Weapons Control and Delivery System
1F15A-34-1-1 Subsystem Description
11F13-29-6-2 Checkout

DESCRIPTION OF TECH DATA FIELD DISCREPANCIES:

TO's are adequate to perform maintenance as authorized. Logic trees are difficult to understand.

DESIGN-FOR-REPAIR CONCEPT DEFINITION

TRAINING & PERSONNEL SKILLS LEVEL

DATE: 17 October 1978

DESCRIPTION OF SKILLS REQUIREMENTS:

Career field designator - 462XX

27 authorized - 48 assigned to support the munitions function in the Equipment Maintenance Squadron at intermediate level maintenance. Organizational level maintenance is handled in the Aircraft Generation Squadron.

DESCRIPTION OF ASSIGNED SKILLS:

Personnel assigned are considered to be satisfactorily qualified mechanically - but deficient in electronic qualifications.

GENERAL COMMENTS:

None

DESIGN-FOR-REPAIR CONCEPT DEFINITION

TROUBLESHOOTING METHODS

DATE: 18 October 1978

DESCRIPTION OF ORGANIZATIONAL TROUBLESHOOTING METHODS:

Maintenance personnel run BIT and use the AN/AWM-72 to check out the Armament Control Subsystem. If a BIT failure is indicated, the Converter-Programmer is generally replaced without using the AN/AWM-72 to confirm the failure. This is because the subsystem BIT is considered to be extremely effective in indicating error presence. While BIT does not identify problem source, the C-P has been found to be the most frequent cause of error presence. Also, since the C-P contains the majority of the timing and firing functions, the time to remove/replace this LRU is less than the 4 hours required to perform an AN/AWM-72 checkout of the weapon system.

DESCRIPTION OF INTERMEDIATE TROUBLESHOOTING METHODS:

- Fault isolation utilizing ATE.
- No particular trouble with ACP but it is time-consuming to troubleshoot.
- High NRTS rate for C-P. C-P is difficult to troubleshoot due to insufficient test detail in task order.
- Checkout of the C-P on the AIS is not operational at this time. The C-P is returned to MACAIR for repair.

DESCRIPTION OF DEPOT TROUBLESHOOTING METHODS:

- Visual inspection of returned LRUs and SRUs.
- Functional test of all returned LRUs to isolate failures to SRU level.
- Semi-automatic testing of SRUs.
- Manual probing to isolate faulty components.
- Functional testing of all repaired LRUs.

NOTE:

ATE diagnostics are not fully developed. In cases where ATE is effective, fault isolation to 3-10 discreet components is obtained.

SECTION V

WEAPONS CONTROL SUBSYSTEM

**DESIGN-FOR-REPAIR CONCEPT DEFINITION
FIELD EVALUATION REPORT**

DATE: 4 October 1978

BASE: CANNON AFB, New Mexico (2-5 October 1978)		WEAPON SYSTEM: F-111D	
PERSONNEL CONTACTED: MSGT Carroll, AGS MSGT D. Neave, CRS *SGT Y. Hudak *SSGT R. McCloud *SSGT B. Harper *SSGT D. Rigney **SSGT Handley **AIC Hepner **SGT R. Scott Heston **SGT Michael W. Woods **SGT Jesse W. Davis **SSGT Philip A. Greathead **SSGT Dale R. Cook * AN/APQ-130 Flightline Maintenance ** AN/APQ-130 Intermediate Maintenance (See Continuation Page)			
SUBSYSTEM CATEGORY: Navigation		WORK UNIT CODE: 73P00	
SUBSYSTEM NOMENCLATURE: Radar Set, Attack AN/APQ-130			
DESCRIPTION OF WEAPON SYSTEM MISSION: The mission of the weapon system is as a tactical fighter/bomber to deliver aerial munitions on designated ground targets.			
DESCRIPTION OF SUBSYSTEM CAPABILITIES: The AN/APQ-130 Attack Radar Set (ARS) is one of the major electronic systems used on the F-111D swing-wing aircraft. State-of-the-art radar techniques are accomplished by sophisticated solid-state circuitry. The purpose of the ARS is to gather precise data for navigation, weapons delivery, and reconnaissance. It examines situations on the ground and in the air in any climatic environment. The ARS will: <ol style="list-style-type: none"> 1. Detect and angle track air or ground targets 2. Perform long range ground mapping with high resolution. 3. Operate from air or ground beacons and directional air-to-air IFF. 			
NUMBER OF LRUs PER SUBSYSTEM: 8 plus equipment rack			
LRU NOMENCLATURE/PART NUMBER: (See attachment on continuation page)			
WEAPON SYSTEM FLIGHT HOURS PER MONTH: 40		SUBSYSTEM FLIGHT HOURS PER MONTH: 40	
SUBSYSTEM GROUND OPERATING TIME PER FLIGHT HOUR: 2.3		EVALUATOR: Gerkin King	

DESIGN-FOR-REPAIR CONCEPT DEFINITION

CONTINUATION PAGE

DATE: 4 October 1978

PERSONNEL CONTACTED: (continued from Page 1)

Mr. Clayton M. Arthur	WR-ALC/MAIPFC
Mr. Duncan C. Feeney	WR-ALC/MAIEF
Mr. Thomas E. Woods	WR-ALC-MAITC
Mr. Ron Fairfield	WR-ALC-AN/APQ-130 Planning
Mr. Paul Copeland	WR-ALC-AN/APQ-130 Maintenance

LRU NOMENCLATURE/PART NUMBER: (continued from Page 1)

73PAO	ANTENNA UNIT (AU)
73PPO	ROLL GIMBAL UNIT (RGU)
73PKO	MICROWAVE RECEIVER UNIT (MRU)
73PHO	LOW VOLTAGE POWER SUPPLY (LVPS)
73PFO	DIGITAL DOPPLER PROCESSOR UNIT (DDPU)
73PBO	ELECTRONICS PROCESSOR UNIT (EPU)
73PDO	TRANSMITTER UNIT (TU)
73PMO	MASTER FREQUENCY GENERATOR (MFG)

INSPECTION REQUIREMENTS (-6):

25 Flight Hours

Change of De-Humidifier (Not an AN/APQ-130 System Component)

AN/APQ-130

No -6 inspection requirement except that if weapon system sits on the ground for 90 days, then the AN/APQ-130 requires a checkout.

DESCRIPTION OF SUBSYSTEM DESIGN CHARACTERISTICS FOR MAINTENANCE:

Operational checkout of attack radar system using a weapon system integrated built-in test capability. This test capability only verifies the failure condition, reports in-flight failures and continuously performs self-tests.

DESCRIPTION OF SPECIAL MAINTENANCE AIDS OR LOCAL MODIFICATIONS:

None

MAINTENANCE CONCEPT - DESIGN:

Organizational level: BIT remove/replace LRU
Repair wiring and associated parts

Quick Fix: (Road Runner) same as above "O" concept except that skilled specialists will perform limited fixes prior to take-off and immediately upon return from a mission.

Intermediate level: Fault Isolate
Remove/replace SRA
Test
Align
Calibrate

Depot level: Fault Isolate
Component repair
Test
Align
Calibrate

OPERATIONAL ENVIRONMENT

Tactical fighter/bomber deployed using the bare base concept. Operational concepts for tactical air forces requires a high degree of flexibility and mobility to attain proficiency in tactical operations. This capability must be established in the following areas:

- . Quick reactions deployment and employment anywhere in the world under any combat conditions.
- . Primary employment in limited war and special warfare operations.
- . Normal employment as a component of a joint force.
- . Operations of extended duration using a wide selection of weapons.
- . Economical operation under any combat situation.
- . Rapid transition from one type of warfare to another.
- . Establish force increments of varying size and type of specialized missions.

MAINTENANCE ENVIRONMENT

The tactical fighter squadron is organized and manned for organizational and field maintenance capability. Organizational level maintenance includes inspection, servicing, fault isolation, removal and replacement of components and systems calibration. Servicing tasks encompass the loading and unloading of munitions. Field maintenance provides intermediate maintenance capability and is organized and capable of supporting the tactical squadrons. This capability is the same at the deployed base as at the home base and includes repair and testing of engines; local manufacture of parts; testing, calibration and repair of aircraft and aerospace ground equipment, assemblies and components; and inspection and repair which is beyond the capability or organizational level maintenance. In addition, a complete precision measurement equipment laboratory is available to support maintenance functions at home base and deployments to a Bare Base.

By necessity, a large portion of required maintenance, e.g., unscheduled/scheduled must be accomplished during the hours of darkness in preparation for the next mission (sortie). Maintenance capability must exist regardless of the hour of the day or weather conditions.

(See continuation page)

NATURAL ENVIRONMENT

Climatic conditions can range throughout the full spectrum of weather. During Bare Base operations, hostility requirements dictate that all operations will be conducted on a 24 hour day, 7 day week basis. The maintenance environment is subjected to extreme climatic variances due to rapid response deployment requirements. The amount of variance encountered relates directly to the degree of maintenance efficiency which may be expected and subsequently the effectiveness of the fighting unit.

Flightline maintenance activities expose both men and equipment to the mercy of the elements. Maintenance is performed around the clock and personnel are exposed to further distraction from high noise levels. Shop maintenance conditions are superior to those experienced on the flightline; however, crowded conditions exist generating a continuing programmed requirement for 24 hour shift work.

DESIGN-FOR-REPAIR CONCEPT DEFINITION

CONTINUATION PAGE

DATE: 4 October 1978

OPERATIONAL ENVIRONMENT

At a Bare Base deployment site the environment is identified by austere facilities, unfamiliar and severe climatic conditions, the increased tempo of operations and personal emotions and physical stress. These bases range in capability from advanced terminals such as Orly in Paris on one extreme to narrow, weed-grown strips in Chad in Africa on the other. In addition, there are numerous other bases, where facilities for personnel support and general housekeeping are adequate, but the maintenance equipment is not equal to current advanced aircraft weapons systems.

MAINTENANCE ENVIRONMENT

The flightline maintenance environment is far from ideal. Flightline maintenance personnel are subjected to distractions of jet engines in operation, taxiing aircraft and jet blast. Use of handbooks and schematics normally associated with flightline maintenance is externally difficult for the reasons stated. Shop maintenance (intermediate maintenance) operations are more extensive than flightline maintenance functions. Even though work requirements may generate a need for around the clock operations and facilities are crowded, work is normally performed in some type of shelter, building, etc.

NATURAL ENVIRONMENT

Climatic conditions of high humidity indirectly affect performance of electronic equipment to some degree. Extreme temperature has a greater effect on maintenance personnel than on equipment. Extremes in temperature and humidity are directly related to the magnitude of the problems encountered and the solutions required to support immediate flight operations.

DESIGN-FOR-REPAIR CONCEPT DEFINITION

ACCESSIBILITY OF AVIONICS

DATE: 4 Oct. 1978

GENERAL DESCRIPTION:

- ° ARS (APG-130) Antenna (AU)/Roll Gimbal (RGU): mounted at front of FWD bulkhead and covered by RADOME accessed by releasing 4 hinged fasteners which secure RADOME to FWD bulkhead, sliding RADOME FWD and swinging it to the right side.
- ° Other 6 LRU's (MRU, LVPs, DDPU, EPU, TU, MGF) are mounted within the left FWD avionics bay and are accessed by removing avionics bay access panel. Removal of the access panel requires disengagement of 13 apex type torqued fasteners.

QUANTITATIVE VALUES:

None available

DESCRIBE SUBSYSTEM REMOVAL:

All ARS LRU's mounted within the F111D avionics bay use jackscrews for electrical connector insertion/extraction and calfax stress panel fasteners for LRU retention. Personnel must release the stress panel fasteners before the jackscrew, and insert the jackscrew before the panel fasteners to prevent electrical connector and/or mount damage, the antenna and roll gimbal LRU's are removed sequentially. The antenna and then the roll gimbal both are bolted in place.

DESIGN-FOR-REPAIR CONCEPT DEFINITION

AGE OF SYSTEM & TECHNOLOGY

DATE: 4 October 1978

GENERAL DESCRIPTION:

The attack radar system AN/APQ-130 was built and installed in the F-111D Weapon System as part of the MARK II avionics package. The design reflects technology of the mid-to late 1960's. The ARS was installed into the airframe around 1970 using a highly sophisticated system integration approach. The AN/APQ-130 is part of the MK-II avionics which was the forerunner to the B-1 avionics package.

TYPE OF COMPONENTS USED:

Discrete solid state components
TWT
ICs
Solder connections

TYPE OF WIRING AND INTERFACE USED:

Interface - Quick disconnect connectors
 - Plug-in LRU's in equipment rack

Wiring - Wiring harness/bundles, waveguides
 - Microdot wiring used

SYSTEM DESIGN APPROACH (ANALOG, DIGITAL, SOFTWARE, ETC.):

Digital
Software
TWT

The AN/APQ-130 is totally integrated into the other weapons system functions with the external integrated central computer complex controlling tactical and maintenance functions. The software programming is hard-wired into the computer.

DESIGN-FOR-REPAIR CONCEPT DEFINITION

DEBRIEFING

DATE: 9 October 1978

DESCRIPTION OF THE DEBRIEFING FUNCTION:

Debriefings are conducted after each flight to allow the flight crew to provide information regarding performance of the aircraft systems during flight and operational evaluation of in-flight events during the mission. Maintenance related data are included by the debriefer on the debriefing form (TAC form 93) who also assigns a JCN to each maintenance discrepancy reported by the flight crew and completes an AFTO 349. During or immediately following each debriefing, the affected squadron "expeditor" is notified of maintenance discrepancies. The expeditor contacts the responsible AGS (A-shop) and monitors corrective maintenance actions. An expeditor is assigned to each TFS.

DESCRIBE THE DEBRIEFING PROCEDURE:

APQ-130 line maintenance personnel do not attend debriefings. If a problem related to the ARS is reported, ARS personnel may be contacted during debriefing. As a result, there are many times when the identification of a probable malfunction is difficult as the flight crew doesn't always recognize if a real problem exists. Generally, maintenance personnel become aware of a radar problem when they are notified by their squadron expeditor to service an aircraft.

DESCRIBE DATA FLOW AND RECORDS:

Flight crew - Debriefing - TAC form 93 - Job Control
AFTO 349 Squadron expeditor - Maint. personnel

Complete AFTO 349 - AFM 66-1 MDCS
AFTO 350

The A-shop (AN/APQ-130) personnel maintain a detailed avionics history log by aircraft tail number which reflects a description of each malfunction and subsequent corrective action. The information documented on the AFTO 349 is not thorough enough to provide the necessary visibility required to perform maintenance. The AFTO 350 documents a discrepancy with any unit and provides the intermediate maintenance personnel with the trouble indication. In the majority of the cases, this information is incomplete. As a result, both flightline and shop personnel must either talk to the person writing the squawk to gain further insight into the malfunction or proceed with a function test to identify the problem area.

DESIGN-FOR-REPAIR CONCEPT DEFINITION

DEPOT SUPPORT

DATE: 9 October 1978

DESCRIPTION OF DEPOT SUPPORT SCOPE:

BIT piece repair of PCC (SRU's) for all LRU's. LRU support for the AN/APQ-130 is at Sacramento with SRU support at Warner Robins.

DEPOT SUPPORT EFFECTIVENESS:

Spare support for the AN/APQ-130 is a continuing problem at bit & piece, SRU, and LRU levels. Because of the age and uniqueness of the MKII avionics package and the less than expected reliability level of the system; maintenance continues to utilize work around procedures to compensate for limited spare resources.

Incompatibility of source selection codes with the maintenance concept exists as it relates to LRU and test equipment repair.

During early program implementation, spare resources are tied-up at various maintenance activities solving functional problems that are normally allocated to support the operational unit.

The depot experience indicates that hybrid support for the AN/APQ-130 is a problem since this item is out of production. Future requirements require contractor to re-tool and produce a limited quantity and/or repair existing hybrids.

COMMENTS:

PCC's returned from depot to field maintenance frequently do not check good in the LRU upon receipt by field maintenance. Field maintenance personnel identified reasons for apparent SRU problems:

- o Test Spec. compatibility between field & depot test equipment
- o Incorporation of modifications at depot level which change the requirements at field level - but field maintenance is not made aware of the change.
- o Unexplained compatibility problems of SRU's (PCC) in LRU's with PCC exhibiting matched set characteristics.

DESIGN-FOR-REPAIR CONCEPT DEFINITION

(PRE, IN, POST) -FLIGHT INSPECTION

DATE: 9 October 1978

DESCRIPTION OF THE INSPECTIONS:

None

FREQUENCY OF INSPECTIONS:

None

PURPOSE OF INSPECTIONS:

None

COMMENTS:

PRE FLIGHT

Flight crew ascertains that video input from the ARS is present, electronic indication of antenna movement and limited operator BIT (ARS lock-on & ranging)

IN FLIGHT

Continuous ARS self-test

POST

None

DESIGN-FOR-REPAIR CONCEPT DEFINITION

LEVEL OF BASE REPAIR

DATE: 9 October 1978

DESCRIPTION OF ORGANIZATIONAL REPAIR:

1. UNSCHEDULED:

Pre & post flight hours troubleshooting - LRU installation and removal. Locally instituted 'Quick-Fix' on flightline. The 'Quick-Fix' concept includes cycling BIT and substituting suspected failed LRU's on flight line prior to and after flight while subsystem is still on A/C power. This approach was developed to increase OR rate of subsystem.

2. SCHEDULED:

None

DESCRIPTION OF INTERMEDIATE REPAIR:

1. UNSCHEDULED:

- o Troubleshooting LRU - Fault isolation to SRU/PCC -- SRU/PCC installation/removal.
- o A hot mock-up is employed for antenna repair/boresighting. All LRU's are tested on the hot mockup prior to being shipped to depot for repair. This mockup is used for isolating problem LRU/SRU's that cannot be repaired at the test station.

2. SCHEDULED:

None

DESCRIPTION OF DEPOT REPAIR:

1. UNSCHEDULED:

- a. PCC/SRU repair
- b. Repair of LRU beyond the capability of intermediate maintenance.
- c. The depot uses semi-automatic test equipment to test and fault isolate LRUs & SRUs.

2. SCHEDULED:

None

DESIGN-FOR-REPAIR CONCEPT DEFINITION

MAINTAINABILITY CHARACTERISTICS OF EQUIPMENT DESIGN

DATE: 12 Oct. 1978

GENERAL DESCRIPTION OF SUBSYSTEM FEATURES:

Solid state circuitry with rear-mounted electrical pin connectors. Cal Fax stress panel fasteners facilitate LRU retention and jackscrews are employed for electrical connector insertion/extraction. Fully integrated subsystem BIT is activated from cockpit. PCC provided for SRU removal/fault isolation.

QUANTITATIVE VALUES:

- | | | |
|---|--|---|
| (1) MTBF - 22 Hours | (2) MTBM - 3.7 Hours @
Organizational Level | (3) MMH/FH - 4.14 Combined
Organizational & Inter-
mediate Levels |
| (4) MTTR - 4.3 Hours Organizational Level
8.3 Hours Intermediate Level | (5) MTBD = 5.4 Hours @ Organiza-
tional Level | |

All values based on AFM 66-1 Data.

QUALITATIVE FEATURES:

- ° BIT
 - Continuous monitoring of primary functions
 - Automatic fault isolation to LRU's
 - Mode status

- ° Easy access to LRU's in avionics bay

COMMENTS:

- BIT is effective in identification of fault presence but does not accurately identify problem source (LRU). The results have been inadequate flightline fault isolation capability which have promoted "shotgun" removals, excessive test time and induced failures.
- Video cables to front of EPU are poorly protected. Repeated removal results in wire breaks.
- Duplexer (waveguide) mounted on equipment rack at forward bulkhead fails due to arcing/blow-out due to moisture collection - resulting pressure loss causes equipment shut down. Removal is extremely difficult and duplexer is for unused air-to-air mode. (The moisture build-up can be traced to saturation of the

DESIGN-FOR-REPAIR CONCEPT DEFINITION

CONTINUATION PAGE

DATE: 12 October 1978

environmental dehumidifier. Replacement every 25 FH is required - but the high maintenance to FH ratio results in unpredictable dehumidifier saturation prior to scheduled removal).

- Rack removal/installation is difficult.
- Pin replacement in connectors is difficult, pin insertion/extractor tools malfunction (break) after 1 - 3 uses.
- Female fitting for jackscrews strip with age/use, repair requires drilling out old fitting and inserting and setting a new fitting.
- Age of wiring is becoming a problem. Vibration and stressing of microdot wiring is causing intermittent shorts and open circuit failures.
- In general, LRU's employ screw-type fasteners to secure case panels. Maintenance personnel would prefer quick release type panel fasteners.
- Antenna mount included matched waveguides. Maintenance personnel would prefer universal waveguide fixtures.
- ARS (APQ-130), especially EPU, is too sensitive to heat and cold. Antenna ranging problems have been encountered during periods of extreme cold (winter).
- Wire breaks in ribbon cable have occurred where ribbon cable is accessible to or handled by organizational and field level maintenance personnel.
- Antenna feed horn position (bore-sight) is extremely sensitive to misalignment due to transportation and handling.
- Field level maintenance personnel indicate that the majority of AN/APQ-130 transmitter problems (60 - 75%) involve blown fuses. Fuses are positioned in such a way as to make replacement difficult. It was suggested that visible circuit breakers would represent a major improvement.
- When EPU is plugged into the test station adapter, maintenance personnel cannot access EPU to make plug/pin checks with meter/scope to verify output readings.
- Cable interface between LRU/test station develop wire breaks and intermittent shorts as the result of bending/flexing required to make connection. Maintenance personnel would like to do away with cables. It is estimated by maintenance personnel that about 50% of maintenance time is employed with problems related to broken wires in connectors and cables at the equipment interface.
- About 25% of the transmitter maintenance requires violation of the environmental integrity of the TWT oil cooling system to repair oil leaks. AN/APQ-130 field level maintenance personnel would like to see the oil cooling system replaced. With their equipment it takes 7 - 8 hours to drain (1 hr), purge (20 min.), repair (N/A), fill (3-3.5 hr) and recirculate (3 - 4 Hr) oil. It should be noted, however, that this oil coolant problem could be the result of the technological level of maintenance equipment. By comparison, current fill-drain systems for similar oil cooled LRU's require about 15 minutes to drain, purge, fill and recirculate oil.

DESIGN-FOR-REPAIR CONCEPT DEFINITION

**MAINTENANCE DATA COLLECTION DOCUMENTATION
& FEEDBACK SYSTEM**

DATE: 17 October 1978

GENERAL DESCRIPTION:

The maintenance data collection is in accordance with the AFR 66-1. This regulation includes mainly organizational changes as it differs to AFR 66-5.

IMPLEMENTED METHODS:

Data are collected on the AFTO Form 349 and 350. The data are keypunched from the AFTO 349 and 350 and then processed to the applicable ALC maintenance data activity.

METHOD(S) EFFECTIVENESS:

Constant review and analysis is performed. The feedback information provided has been effective but is dependent upon the need for a qualified analyst.

COMMENTS:

The A-shop personnel maintain an avionics history log by aircraft tail number which describes the malfunction and corrective action.

DESIGN-FOR-REPAIR CONCEPT DEFINITION

MAINTENANCE ORGANIZATION

DATE: 31 October 1978

GENERAL DESCRIPTION:

The maintenance organization is in accordance with AFR 66-5.

MAINTENANCE ORGANIZATION FLOW CHART:

The maintenance activities for the AN/APQ-130 are part of the aircraft generation squadron for organizational level maintenance.

(SEE ATTACHED CHARTS)

DESIGN-FOR-REPAIR CONCEPT DEFINITION

CONTINUATION PAGE

DATE: 31 October 1978

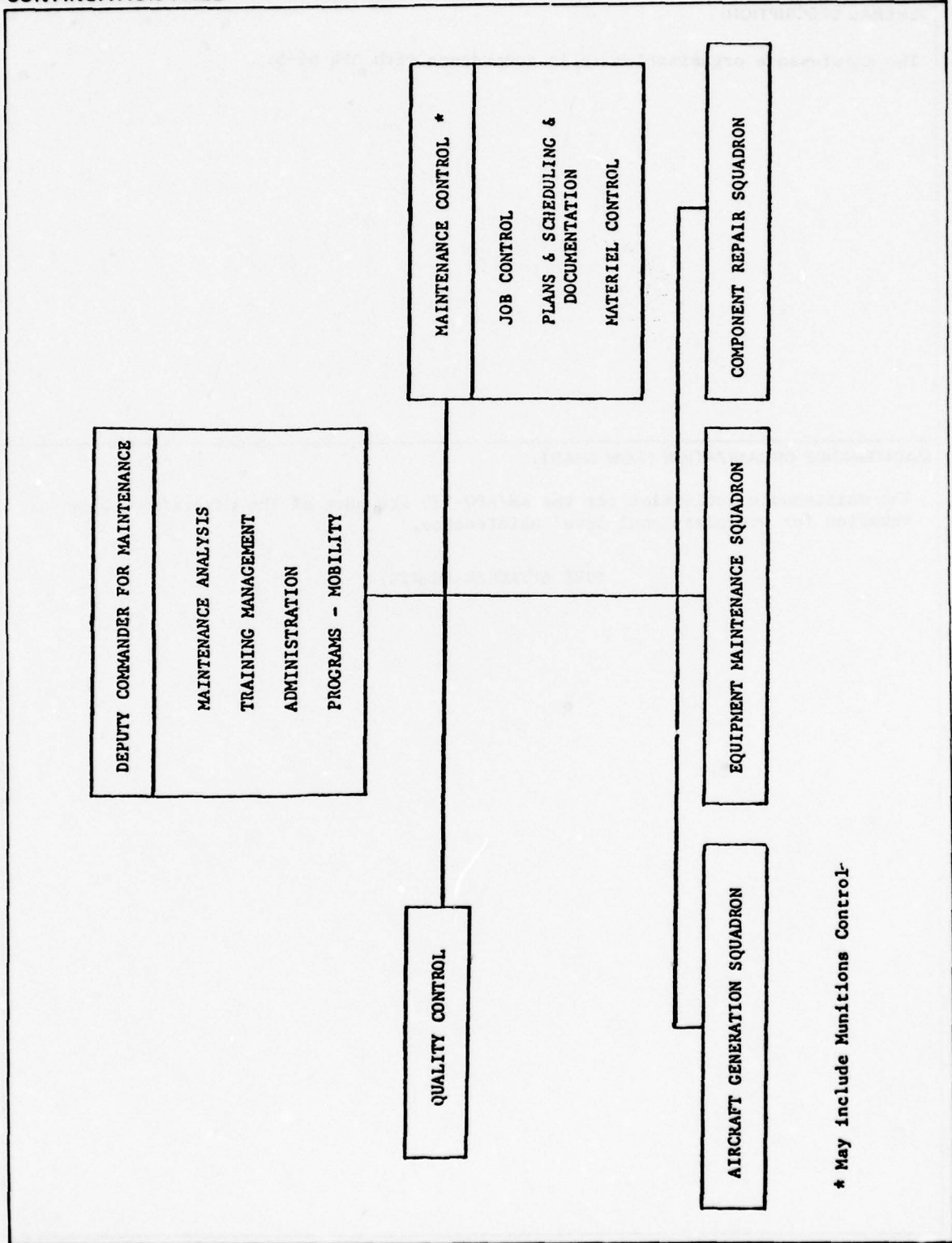

* May include Munitions Control

DESIGN-FOR-REPAIR CONCEPT DEFINITION

CONTINUATION PAGE

DATE: 31 October 1978

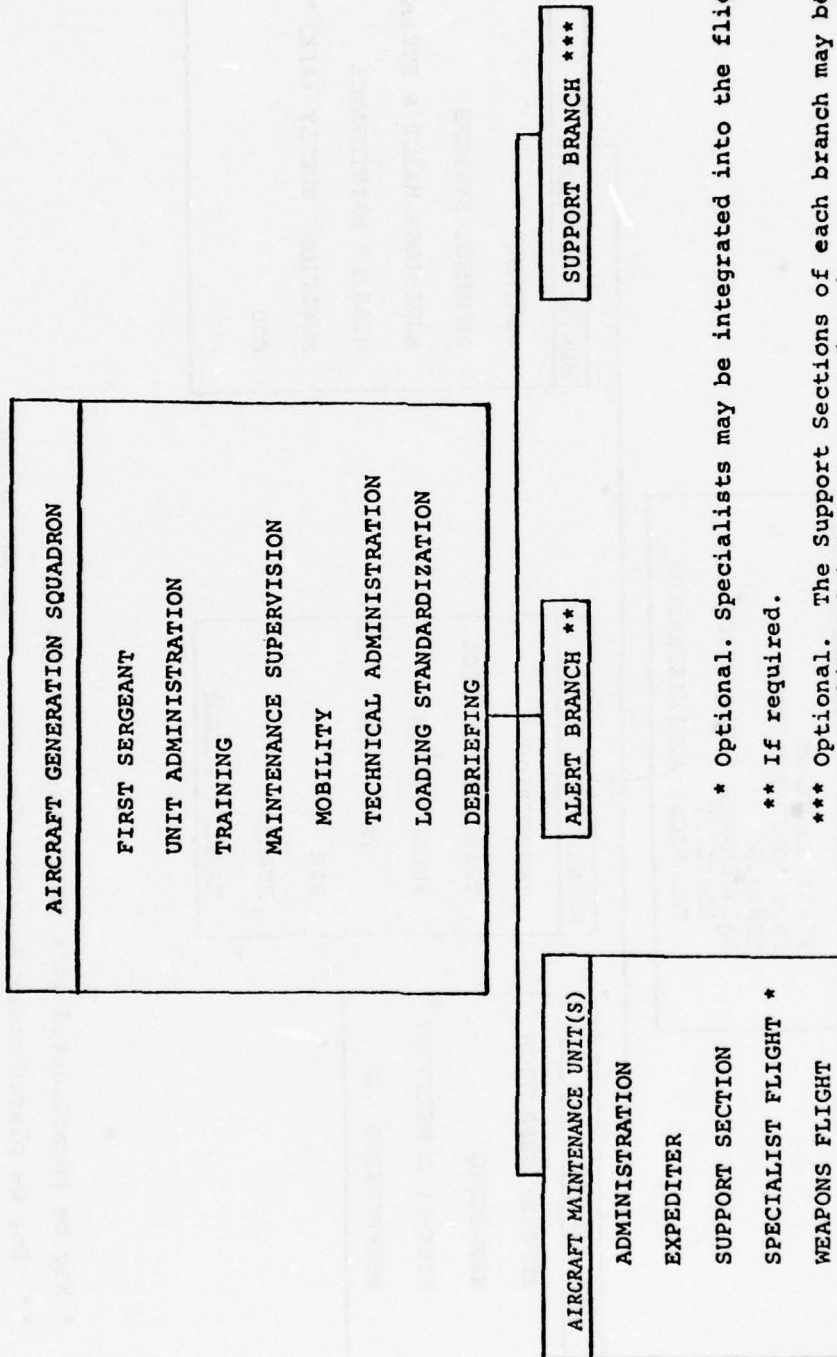

* Optional. Specialists may be integrated into the flights.

** If required.

*** Optional. The Support Sections of each branch may be consolidated into a Support Branch.

DESIGN-FOR-REPAIR CONCEPT DEFINITION

CONTINUATION PAGE

DATE: 31 October 1978

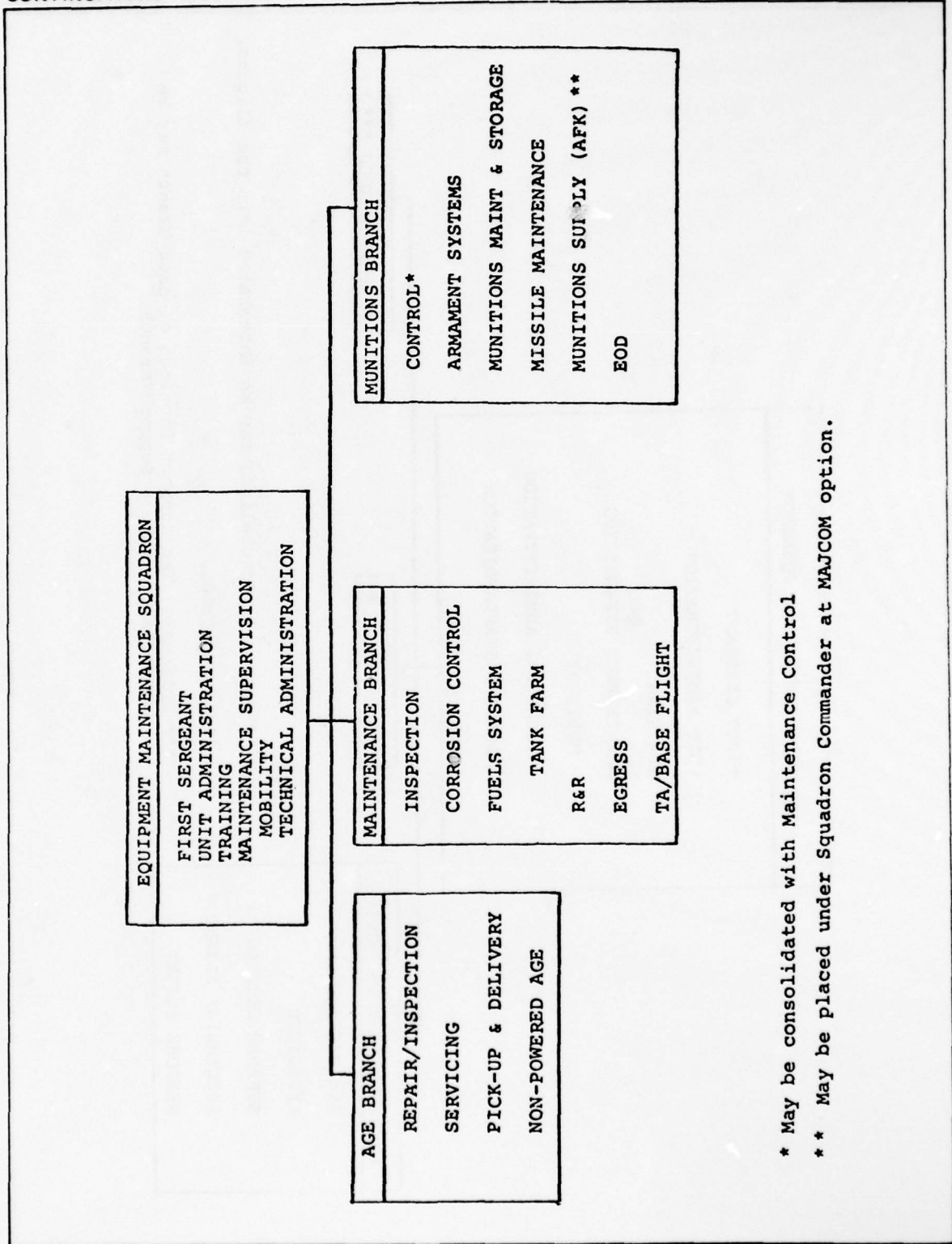

* May be consolidated with Maintenance Control

** May be placed under Squadron Commander at MAJCOM option.

DESIGN-FOR-REPAIR CONCEPT DEFINITION

CONTINUATION PAGE

DATE: 31 October 1978

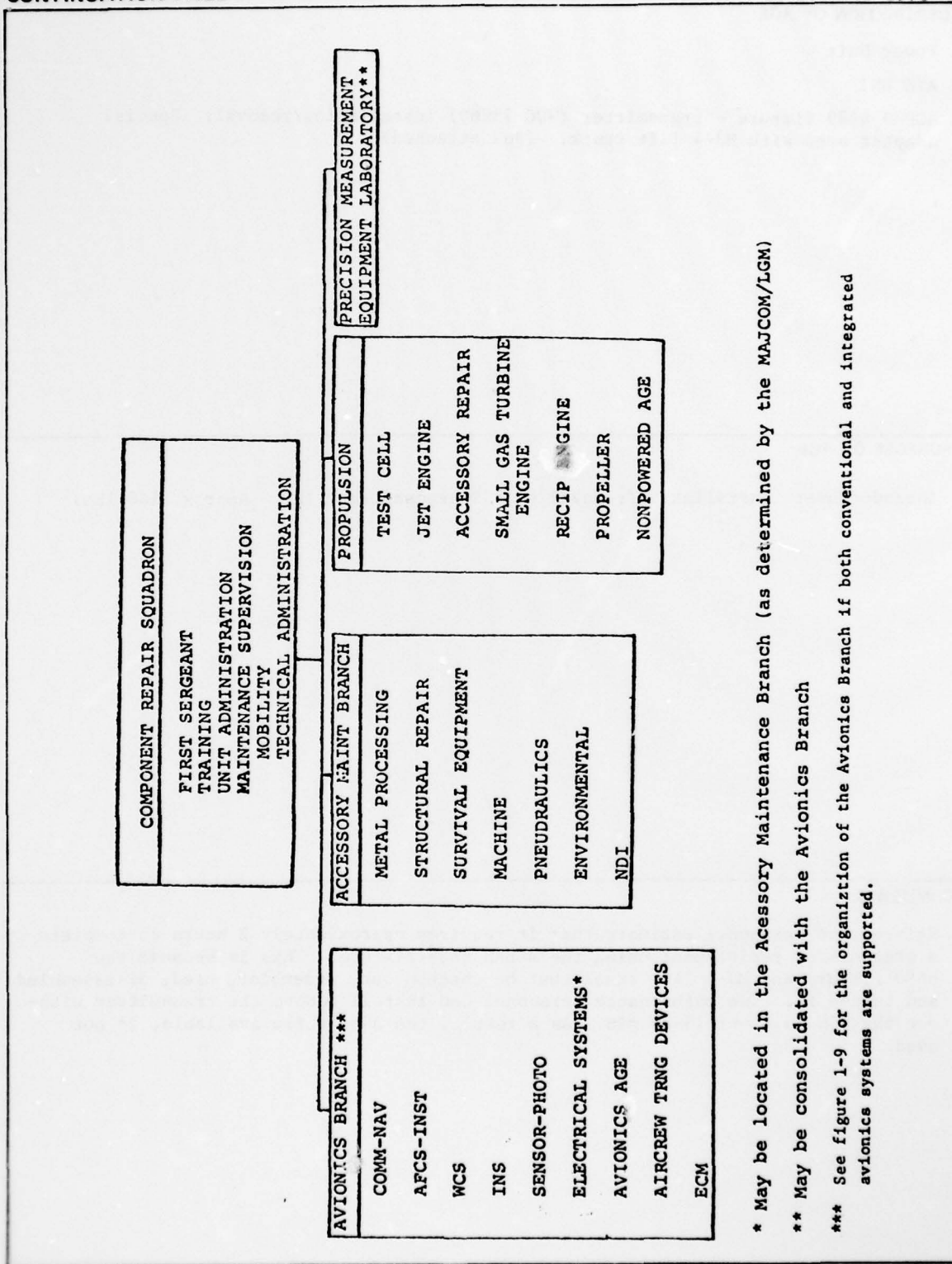

* May be located in the Accessory Maintenance Branch (as determined by the MAJCOM/LGM)

** May be consolidated with the Avionics Branch

*** See figure 1-9 for the organization of the Avionics Branch if both conventional and integrated avionics systems are supported.

DESIGN-FOR-REPAIR CONCEPT DEFINITION

ORGANIZATIONAL LEVEL AGE

DATE: 4 October 1978

DESCRIPTION OF AGE:

Power Unit

A/C UNT

AGERD 6689 fixture - transmitter (WUC 73PDO) installation/removal. Special adapter used with MJ-4 lift truck. (See attached)

PURPOSE OF AGE:

Intended use: Installation/removal of ARS transmitter. (WT = Approx. 140 lbs)

COMMENTS:

Maintenance personnel estimate that it requires approximately 2 hours to complete a transmitter replacement using the AGERD 6689 fixture. This is because the 6689 fixture and MJ-4 lift truck must be checked out, assembled, used, disassembled and turned in. Two maintenance personnel can install/remove the transmitter without the AGE in about 15-20 min. As a result, the AGE, while available, is not used.

DESIGN-FOR-REPAIR CONCEPT DEFINITION

CONTINUATION PAGE

DATE: 4 October 1978

AGERD 6689 FIXTURE

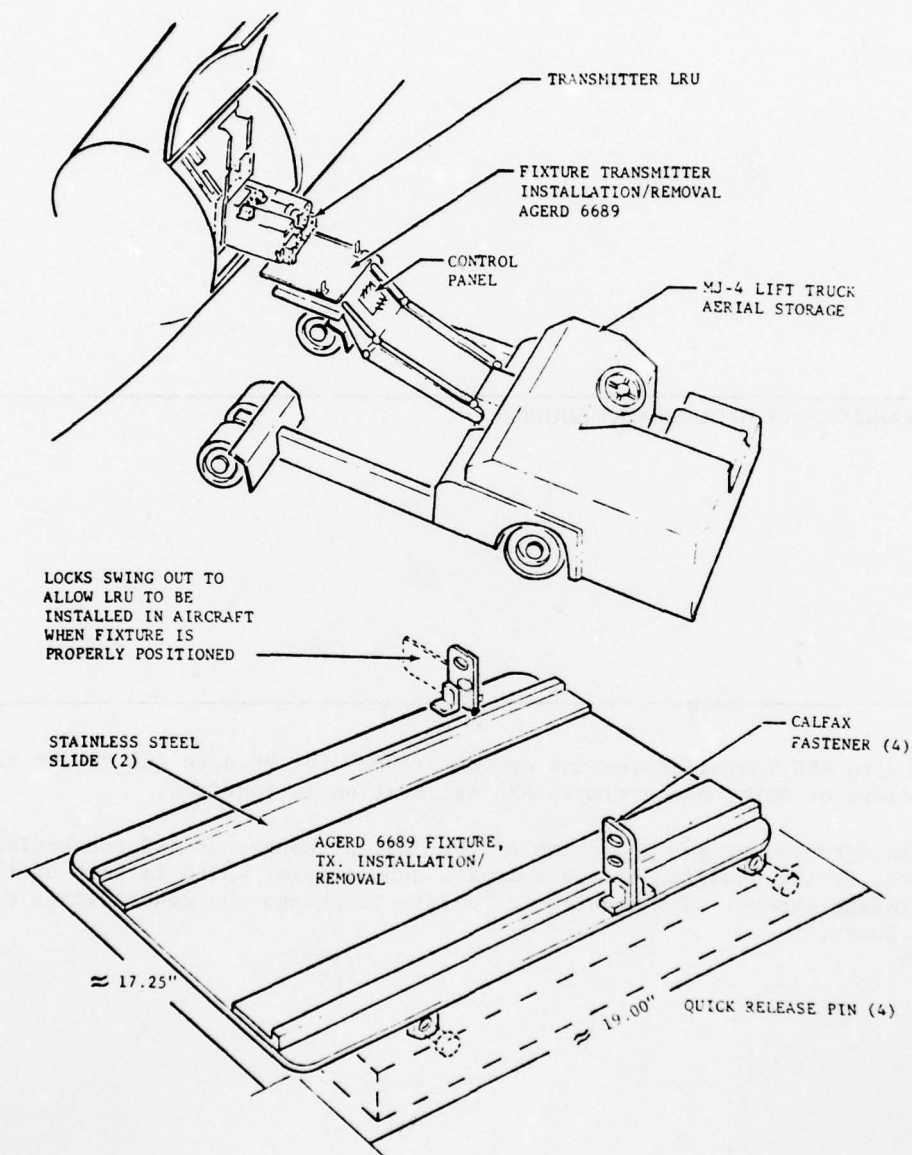

DESIGN-FOR-REPAIR CONCEPT DEFINITION

PREVENTIVE MAINTENANCE

DATE: 9 October 1978

GENERAL DESCRIPTION:

There is not a preventive maintenance schedule for the APQ-130 RADAR.

PREVENTIVE MAINTENANCE REQUIREMENT SOURCE:

None

COMMENTS:

If an A/C with ARS installed remains on the grounds for 90 days (no flight time and regardless of maintenance time), ARS calibration is required.

Of importance to the proper operation of the ARS, although not ARS preventive maintenance, is the changing of the avionics dehumidifier which is part of the A/C ventilation system. The requirement exists to change the dehumidifier every 25 flight hours.

DESIGN-FOR-REPAIR CONCEPT DEFINITION

TECHNICAL ORDERS

DATE: 9 October 1978

DESCRIPTION OF TECH DATA REQUIREMENTS:

ARS subsystem - 12P2 - 2APQ130-2

Line: 1F111D-2-19-3
 1F111D-2-23
 1F111D-4-23
 1F111D-2-5-1-2CC-1
 1F111D-2-14

<u>Field:</u>	<u>CHECKOUT</u>	<u>IPB</u>	<u>OVERHAUL</u>
Transmitter	12P2-2APQ130-68-1	12P2-2APQ130-64	12P2-2APQ130-63
MSTR Freq Gen	" 38-1	" 34	" 33
Micro Rcvr Unit	" 48-1	" 44	" 43
Electronic Proc	" 28-1	" 24	" 23
DDPU	" 88-1	" 84	" 83
Ant/Roll Gimbal	" 98-1	" 94	" 93
LVPS			
<u>ARS Antenna Shack</u>	12P2-2APQ130-2-1		

DESCRIPTION OF TECH DATA FIELD DISCREPANCIES:

Transmitter - Poor Technical Order description regarding test points.

- General
- 1) Insufficient technical data to trace signals. Problem isolation becomes cumbersome due to the requirement for multiple technical orders to troubleshoot. Data is limited or missing regarding test points and signal values.
 - 2) The flightline technical orders provide insufficient visibility for signal flow at the system level.
 - 3) The AN/APQ-130 technical data is good about describing the box function and its interface with other MARK II avionics subsystems.

DESIGN-FOR-REPAIR CONCEPT DEFINITION

TRAINING & PERSONNEL SKILLS LEVEL

DATE: 9 October 1978

DESCRIPTION OF SKILLS REQUIREMENTS:

The authorized skill requirements, while not available, were indicated as being adequate to meet the maintenance concept. Experience on this system is the biggest asset in affecting an effective repair.

DESCRIPTION OF ASSIGNED SKILLS:

<u>ORG. MAINT.</u>	<u>9 Level</u>	<u>7 Level</u>	<u>5 Level</u>	<u>3 Level</u>
481st AMU	1	1	10	9
522 AMU	0	2	19	11
523 AMU	1	2	13	9
524 AMU	2	3	13	10
TOTAL	4	8	55	39

The organizational maintenance activity for avionics is in the aircraft generation squadron and manned at approximately 58 percent of authorized levels. The intermediate maintenance activity for avionics is in the component repair squadron and manned at authorized levels.

GENERAL COMMENTS:

Basic training in electronics on the AN/APQ-130 is adequate; however, the system requires extensive OJT for one to become proficient. The integration of the female technicians into the maintenance complex is wide spread and requires reevaluation of the human factor aspects of the equipment/support system design.

DESIGN-FOR-REPAIR CONCEPT DEFINITION

TROUBLESHOOTING METHODS

DATE: 9 October 1978

DESCRIPTION OF ORGANIZATIONAL TROUBLESHOOTING METHODS:

Visual checks of antenna operation and video output. Built-in-test (BIT) - provide testing of each mode of the radar operation along with a single test of all modes of operation (single & sequence mode tests).

Maintenance personnel consider subsystem BIT to be effective in identification of problem presence but not problem source. Consequently, LRU replacement frequently fails to resolve problem. High level of system integration apparently results in erroneous/spurrious indications which require temporal analysis.

DESCRIPTION OF INTERMEDIATE TROUBLESHOOTING METHODS:

LRU troubleshooting using test set (Receiver Transmitter Modulator-RTM). Primary method is fault isolation with semi-automatic test modes employing central computer processing.

Maintenance personnel have extremely low confidence in RTM which is apparently the source of spurrious fault indications. As a result, a great deal of manual PCC checking is performed to resolve failures.

A hot mock-up is used to screen and solve unresolved problems resulting from test station. The functional layout within a LRU requires jumping around to different SRU's to troubleshoot a signal path.

DESCRIPTION OF DEPOT TROUBLESHOOTING METHODS:

- o Visual inspection of returned LRU's and SRU's
- o Functional test of all returned LRU's to isolate failures to SRU level.
- o Manual probing to isolate faulty components.
- o Functional testing of all repaired LRU's.

NOTE:

- Maintenance personnel find that TO's are adequate to perform required maintenance, but that it is sometimes cumbersome to trace necessary data through multiple TO's.
- ATE diagnostics are not fully developed. In cases where ATE is effective, fault isolation to 3-10 discreet components is obtained.

**DESIGN-FOR-REPAIR CONCEPT DEFINITION
FIELD EVALUATION REPORT**

DATE: 18 October 1978

BASE: Langley AFB (2-4 October 1978)		WEAPON SYSTEM: F-15	
PERSONNEL CONTACTED:			
Col. Laird	SSGT Dinges	AIC Smith	
CMS Phillips	SSGT Chevront	AIC Hoffman	
SMSGT R. Brown	SGT Haupt	AIC Woods	
MSGT Leburn	SGT Lawson	AIC Garland	
MSGT Willis	AIC Logge	AIC Terek	
SSGT Allran	AIC McGill	*Mr. Horace Pritchett	
SSGT St. Germain	AIC Trahan	*Mr. Paul Fincher	
		*Warner Robins (See Attached)	
SUBSYSTEM CATEGORY: WEAPON CONTROL		WORK UNIT CODE: 74F00	
SUBSYSTEM NOMENCLATURE: AN/APG-63 RADAR SET			
DESCRIPTION OF WEAPON SYSTEM MISSION:			
The mission of the weapon system is as a tactical fighter/bomber to deliver munitions on designated ground targets and missiles/rapid-fire general ordnance during air-combat situations.			
DESCRIPTION OF SUBSYSTEM CAPABILITIES:			
The radar set is an high frequency, pulse doppler attack radar designed primarily for air-to-air combat. The radar provides target range, range rate, antenna angles and angular rates to the A/C central computer for the computation of the selected weapon attack mode parameters.			
NUMBER OF LRUs PER SUBSYSTEM: 23 LRU's (9 Powered LRU's (14 Non-powered LRU's			
LRU NOMENCLATURE/PART NUMBER: See Attached			
WEAPON SYSTEM FLIGHT HOURS PER MONTH: 20.0		SUBSYSTEM FLIGHT HOURS PER MONTH: 20.0	
SUBSYSTEM GROUND OPERATING TIME PER FLIGHT HOUR: 0.5		EVALUATOR: Gerkin King	

DESIGN-FOR-REPAIR CONCEPT DEFINITION

CONTINUATION PAGE

DATE: 18 October 1978

*Clayton M. Arthur

WR-ALC/MAIPFC

*Duncan C. Feeney

WR-ALC/MAIEF

*Thomas E. Woods

WR-ALC/MAITC

DESIGN-FOR-REPAIR CONCEPT DEFINITION

CONTINUATION PAGE

DATE: 18 October 1978

LRU NOMENCLATURE

	<u>HAC P/N</u>	<u>AN Nomenclature</u>	<u>WUC</u>
Radar Set	● 3173000	AN/APG-63	74FOO
● Oscillator, Radio Frequency	● 3173001	O-1620/APG-63	74FJO
Waveguide Assembly	3173006	CG-3701/APG	74FPA
● Transmitter, Radar	● 3173011	T-1208/APG-63	74FAO
Waveguide Assembly	3173012	CG-3703/APG	74FPC
Horn, Waveguide	3173019	AS-2711/APG	74FLO
Waveguide Assembly	3173020	CG-3704/APG	74FPD
Waveguide Assembly	3173021	CG-3705/APG-63	74FPE
● Receiver, Radar	● 3173022	R-1765/APG	74FCO
Waveguide Assembly	3173023	CG-3706/APG	74FPE
● Antenna	● 3173031	AS-2712/APG	74FUO
● Processor, Radar Target Data, Analog	● 3173039	MX-9100/APG	74FSO
● Processor, Radar Target Data, Digital	● 3173041	MX-9098/APG	74FFO
● Processor, Radar Data	● 3173081	MX-9099/APG	74FQO
● Control, Radar Set	● 3173541	C-8894/APG	74FKO
● Power Supply	● 3173610	PP-6682/APG	74FHO
Antenna-Radome, Missile Illumination, LHR	3173721	AS-2713/APG	74FMB
Antenna-Radome, Missile Illumination, RHR	3173722	AS-2714/APG	74FME
Divider, Power, Radio Frequency, Forward	3173723	MX-9101/APG	74FMA
Antenna-Radome, Missile Illumination, LHF	3173724	AS-2750/APG	74FMJ
Antenna-Radome, Missile Illumination, RHF	3173725	AS-2749/APG	74FMH
Divider, Power, Radio Frequency, LH	3173726	MX-9160/APG	74FML
Divider, Power, Radio Frequency, RH	3173727	MX-9161/APG	74FMM

INSPECTION REQUIREMENTS (-6):

None

DESCRIPTION OF SUBSYSTEM DESIGN CHARACTERISTICS FOR MAINTENANCE:

Operational checkout of Radar System using a weapon system integrated BIT. The radar BIT checks radar performance, and checks the validity of radar parameters input to the central computer. Further details are explained in the maintainability characteristics section of this report

DESCRIPTION OF SPECIAL MAINTENANCE AIDS OR LOCAL MODIFICATIONS:

None

MAINTENANCE CONCEPT - DESIGN:

Organizational:	BIT R/R LRU
Intermediate:	Fault Isolate R/R SRA/Modules Test/Align/Calibrate
Depot:	Fault Isolate Component Repair Test/Align/Calibrate

OPERATIONAL ENVIRONMENT

Tactical fighter/bomber deploys using the Bare Base Concept.

Operational concepts for tactical air forces requires a high degree of flexibility and mobility to attain proficiency in tactical operations. This capability must be established in the following areas:

- Quick-reactions deployment and employment anywhere in the world under any combat conditions
- Primary employment in limited war and special warfare operations
- Normal employment as a component of a joint force
- Operations of extended duration using a wide selection of weapons
- Economical operation under any combat situation
- Rapid transition from one type of warfare to another
- Establish force increments of varying size and type for specialized missions

MAINTENANCE ENVIRONMENT

The tactical fighter squadron is organized and manned for organizational and field maintenance capability. Organizational level maintenance includes inspection, servicing, fault isolation, removal and replacement of components and system calibration. Servicing tasks encompass the loading and unloading of munitions. Field maintenance provides intermediate maintenance capability and is organized and capable of supporting the tactical squadrons. This capability is the same at the deployed base as at the home base and includes repair and testing of engines; local manufacture of parts; testing, calibration and repair of aircraft and aerospace ground equipment, assemblies and components; and inspection and repair which is beyond the capability of organizational level maintenance. In addition, a complete precision measurement equipment laboratory is available to support maintenance functions at home base and deployments to a Bare Base.

By necessity, a large portion of required maintenance, e.g., unscheduled/scheduled, must be accomplished during the hours of darkness in preparation for the next mission (sortie). Maintenance capability must exist regardless of the hour of the day or weather conditions. The flightline maintenance environment is far from ideal. Flightline maintenance personnel are subjected to distractions

NATURAL ENVIRONMENT

Climatic conditions can range throughout the full spectrum of weather. During Bare Base operations, hostility requirements dictate that all operations will be conducted on a 24-hour day, 7-day week basis. The maintenance environment is subjected to extreme climatic variances due to rapid response deployment requirements. The amount of variance encountered relates directly to the degree of maintenance efficiency which may be expected and subsequently the effectiveness of the fighting unit.

Flightline maintenance activities expose both men and equipment to the mercy of the elements. Maintenance is performed around the clock and personnel are exposed to further distraction from high noise levels. Stop maintenance conditions are superior to those experienced on the flightline; however, crowded conditions exist generating a continuing programmed requirement for 24 hour shift work.

Climatic conditions of high humidity indirectly affect performance of electronic equipment to some degree. Extreme temperature has a greater effect on

DESIGN-FOR-REPAIR CONCEPT DEFINITION

CONTINUATION PAGE

DATE: 19 October 1978

OPERATIONAL ENVIRONMENT (Continued)

At a Bare Base deployment site the environment is identified by austere facilities, unfamiliar and severe climatic conditions, the increased tempo of operations, and personal emotional and physical stress. These bases range in capability from advanced terminals such as Orly in Paris on one extreme to narrow, weed-grown strips in Chad in Africa on the other. In addition, there are numerous other bases, where facilities for personnel support and general housekeeping are adequate, but the maintenance equipment is not equal to current advanced aircraft weapons systems.

MAINTENANCE ENVIRONMENT (Continued)

of jet engines in operation, taxiing aircraft and jet blast. Use of handbooks and schematics normally associated with flightline maintenance is externally difficult for the reasons stated. Shop maintenance (intermediate maintenance) operations are more extensive than flightline maintenance functions. Even though work requirements may generate a need for around the clock operations and facilities are crowded, work is normally performed in some type of shelter, building, etc.

NATURAL ENVIRONMENT (Continued)

maintenance personnel than on equipment. Extremes in temperature and humidity are directly related to the magnitude of the problems encountered and the solutions required to support immediate flight operations.

DESIGN-FOR-REPAIR CONCEPT DEFINITION

ACCESSIBILITY OF AVIONICS

DATE: 19 October 1978

GENERAL DESCRIPTION:

The radar set consists of nine major LRUs and connecting waveguides. The majority of the units are mounted in the forward left nose equipment bay. The antenna (031) is in the radome and the RADAR control panel (541) is in the front cockpit left console. In general, there are no accessibility problems.
(SEE ATTACHMENT A)

QUANTITATIVE VALUES:

None available. However, in general, most units are removed within a 5 minute time interval.

DESCRIBE SUBSYSTEM REMOVAL:

LRU removal at the aircraft variously requires disconnecting multi-lead electrical cables, coaxial cables, liquid cooling quick-disconnects and waveguide quick-disconnects. LRUs are held in place by rack-mounted, swing-latch bolts. After disconnecting swing-latch bolts, the LRUs are slid along the rack rails and lifted from the aircraft. Antenna removal requires unlocking the nose radome and swinging it to the full right position, disconnecting multi-lead electrical cables, coaxial cables, hydraulic quick-disconnect connectors, and waveguide assemblies. Antenna removal is completed by removing four hard-mounted bolts and installing the antenna into a handling fixture.

AD-A080 496

HUGHES AIRCRAFT CO CANOGA PARK CALIF MISSILE SYSTEMS--ETC F/G 1/3
DESIGN-FOR-REPAIR CONCEPT DEFINITION VOLUME III. FIELD EVALUATI--ETC(U)
AUG 79 F A GERKIN, J L GREEN, J M KING F33615-78-C-1461
MSG-9285-VOL-3 AFAL-TR-79-1130-VOL-3 NL

UNCLASSIFIED

3 OF 3

AD
A080496



END
DATE
FILMED
8 - 80
- DDC

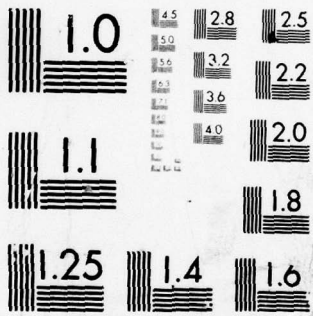

MICROCOPY RESOLUTION TEST CHART
NATIONAL BUREAU OF STANDARDS-1963-A

CONTINUATION PAGE

DATE: 19 October 1978

LEGEND

- 1 F-15A
- 2 TF-15A
- 3 F-15A 77-0061 AND UP, TF-15A 77-0154 AND UP.
- 4 F-15A 73-006 THRU 73-105 AND TF-15A 73-108 THRU 73-114 AFTER TO 1F-15A-664 BUT BEFORE TO 1F-15A-681; ALSO 73-106 THRU 74-136 AND TF-15A 74-137 THRU 74-142 BEFORE TO 1F-15A-681.

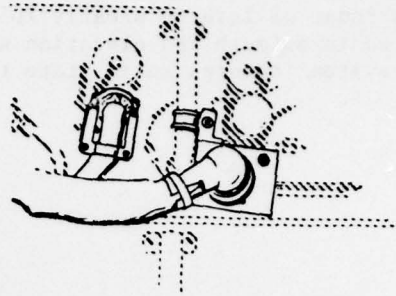

4 RADAR OVERHEAT PROTECTION UNIT

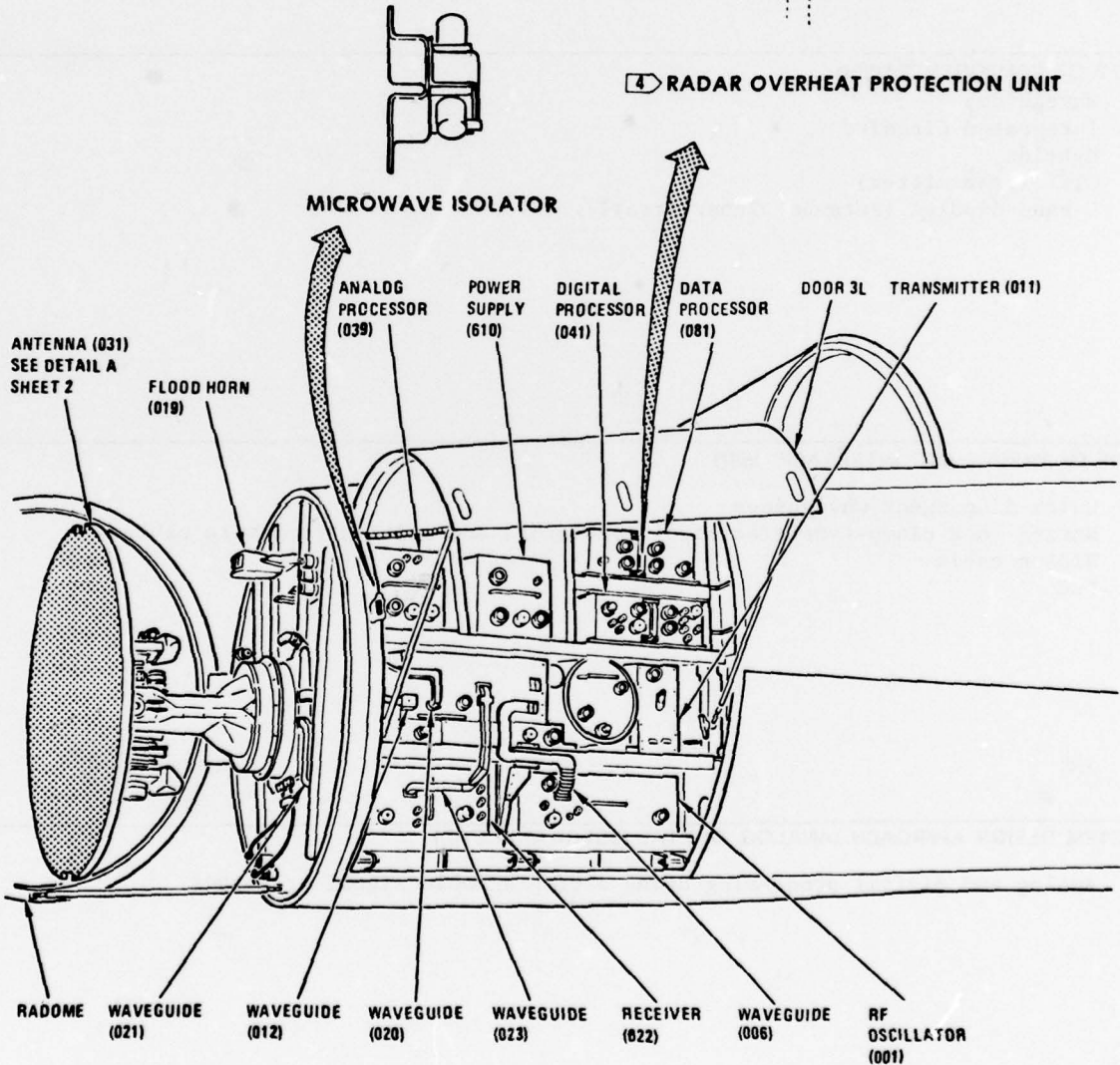

DESIGN-FOR-REPAIR CONCEPT DEFINITION

AGE OF SYSTEM & TECHNOLOGY

DATE: 19 October 1978

GENERAL DESCRIPTION:

The AN/APG-63 is a high frequency, pulse doppler, multiple prf, multi-mode attack radar of late 60's/early 70's design. The antenna is hydraulically actuated in azimuth and elevation while the roll gimbal is motor driven. The radar system features solid state technology.

TYPE OF COMPONENTS USED:

Waveguides
Integrated Circuits
Hybrids
GTWT (transmitter)
L band dipoles (antenna planar array)

TYPE OF WIRING AND INTERFACE USED:

Quick disconnect waveguides
Spring lock clamp-type electrical connectors and multi-strand wire cables
Ribbon cable
PCC

SYSTEM DESIGN APPROACH (ANALOG, DIGITAL, SOFTWARE, ETC.):

Analog and digital processing using a programmable signal processor

DESIGN-FOR-REPAIR CONCEPT DEFINITION

DEBRIEFING

DATE: 19 October 1978

DESCRIPTION OF THE DEBRIEFING FUNCTION:

Debriefings are conducted following each flight to allow the pilot to provide information regarding performance of the A/C systems during flight and operational evaluation of in-flight events.

DESCRIBE THE DEBRIEFING PROCEDURE:

Maintenance related data are recorded by the debriefer on TAC Form 93 (Debriefing Form). A JCN is assigned each discrepancy and an AFTO 349 is completed. AN/APG-63 maintenance personnel do not attend the debriefing. Discrepancies are reported using the AFTO 349.

DESCRIBE DATA FLOW AND RECORDS:

AN/APG-63 maintenance personnel complete the AFTO 349 and this data enters the the AFM 66-1 MDCS. The information documented on the AFTO 349 is not thorough enough to provide the necessary visibility required to perform maintenance. The AFTO 350 documents a discrepancy with any unit and provides the intermediate maintenance personnel with the trouble indication. In the majority of cases, the information provided by the AFTO 350 is incomplete. As a result, both flightline and shop personnel must either talk to the person who initiated the malfunction report to gain further insight, or proceed with a functional test to identify the problem area.

DESIGN-FOR-REPAIR CONCEPT DEFINITION

DEPOT SUPPORT

DATE: 19 October 1978

DESCRIPTION OF DEPOT SUPPORT SCOPE:

- BIT and piece repair of all SRUs
- SRU and component repair of LRUs beyond the capability of intermediate maintenance.
- Functional check-out of all repaired LRUs

Depot support for the AN/APG-63 is at Warner-Robins.

DEPOT SUPPORT EFFECTIVENESS:

Spare support for the AN/APG-63 is a continuing problem at the SRU and LRU levels. During early program implementation, spare resources, that are normally allocated to support the operational unit, are tied-up at various maintenance activities solving functional problems. Estimated depot maintenance times for the AN/APG-63 are:

<u>NAME</u>	<u>AVG M/H</u>	<u>RANGE</u>
Transmitter (011) -----	16	----- 9-20
Antenna (031) -----	25	----- 20-35
Analog Processor (039) -----	20	----- 10-25
Data Processor (081) -----	12	----- 8-14
Control (541) -----	8	----- 6-9
Power Supply (610) -----	15	----- 12-18

Maintenance continues to utilize work around procedures to compensate for limited spare resources.

COMMENTS:

- Due to the paucity of system spares, some modules, classified as throw-away, are being saved and sent to the depot for repair. Since the intermediate level test stations are only partially up and running, many LRUs are being sent to the depot for repair.
- Ninety percent (90%) of the URs (Unsatisfactory Reports) received by the depot are for the Analog Processor (039). Of URs received, 50% test good and over 45% are problems associated with test tolerances.

DESIGN-FOR-REPAIR CONCEPT DEFINITION

CONTINUATION PAGE

DATE: 19 October 1978

DEPOT SUPPORT EFFECTIVENESS (Continued)

During early program implementation, spare resources are tied-up at various maintenance activities solving functional problems that are normally allocated to support the operational unit.

DESIGN-FOR-REPAIR CONCEPT DEFINITION

(PRE, IN, POST) -FLIGHT INSPECTION

DATE: 19 October 1978

DESCRIPTION OF THE INSPECTIONS:

None

FREQUENCY OF INSPECTIONS:

None

PURPOSE OF INSPECTIONS:

None

COMMENTS:

None

DESIGN-FOR-REPAIR CONCEPT DEFINITION

LEVEL OF BASE REPAIR

DATE: 19 October 1978

DESCRIPTION OF ORGANIZATIONAL REPAIR:

1. UNSCHEDULED:

- Fault isolate AN/APG-63 to LRU level using system BIT.
- Remove and replace LRU's

2. SCHEDULED:

None

DESCRIPTION OF INTERMEDIATE REPAIR:

1. UNSCHEDULED:

- Fault isolate LRU to SRU
- Remove and replace SRU's

2. SCHEDULED:

DESCRIPTION OF DEPOT REPAIR:

1. UNSCHEDULED:

- SRU repair
- Repair of LRU's beyond the capability of intermediate maintenance

2. SCHEDULED:

None

DESIGN-FOR-REPAIR CONCEPT DEFINITION

MAINTAINABILITY CHARACTERISTICS OF EQUIPMENT DESIGN

DATE: 19 October 1978

GENERAL DESCRIPTION OF SUBSYSTEM FEATURES:

The AN/APG-63 Radar Set consists of nine major LRU's and connecting waveguides. The majority of the units are mounted in the forward left nose equipment bay. The antenna is in the radome and the Radar Control Panel is in the front cockpit left console.

The AN/APG-63 has solid state circuitry with quick disconnect cannon-type plugs for wiring interface to and between LRU's; quick disconnect swing - latch fasteners provide for simplified installation/removal of waveguides and LRU's.

The radar BIT (Built-In-Test) System checks radar performance and checks the validity of radar parameters input to the weapon system central computer. Each major LRU has a BIT fault indicator. There are two types of BIT provided in the system. One provides inflight continuous monitoring and the other is operator initiated to determine unit and overall system status. The BIT determines if there is a fault and if that fault can be traced to an LRU.

QUANTITATIVE VALUES:

- | | | |
|--|---|--|
| (1) MTBF - 44 Hours | (2) MTBM - 4.7 Hours @
Organizational Level | (3) MMH/FH - 2.2 Combined
Organizational & Inter-
mediate Levels |
| (4) MTTR - 3.5 Hours Organizational Level
11.9 Hours Intermediate Level | (5) MTBD - 11.4 Hours @ Organi-
zational Level | |

Based on AN/APG-63 AFM 66-1 data

QUALITATIVE FEATURES and Comments:

- LRU BIT indicators provide a quick method of identifying LRU's which have failed BIT. Transient glitches may be identified by resetting the indicator (recycle BIT).
 - The AN/APG-63 system BIT is reported to be 70-80% reliable for indication of fault presence and identification of specific faulty LRU.
 - Both organizational and intermediate level maintenance personnel have noted apparent tolerance differences between depot and intermediate test equipment and AN/APG-63 BIT. This situation has affected the designed universal utilization of LRU's. The LRU's will sometimes exhibit a tendency to operate as matched sets. The situation can be resolved by changing the system configuration.
-
- A hot mockup is desired to screen suspected LRU's and provide for functional testing of repaired LRU's.
 - Troubleshooting of the Transmitter (011) at the field maintenance level requires draining of the liquid coolant (oil). Technicians would prefer that the test points and repair features be so designed and located that the majority of the troubleshooting and repair could be performed without violating the environmental integrity of the cooling system.
 - It takes 45 minutes to an hour to drain, purge, fill and recirculate the AN/APG-63 Transmitter cooling system. Maintenance technicians consider this time to be excessive. It should be noted, however, that the oil coolant

DESIGN-FOR-REPAIR CONCEPT DEFINITION

CONTINUATION PAGE

DATE: 19 October 1978

GENERAL DESCRIPTION OF SUBSYSTEM FEATURES: (Continued)

Fault indicators are provided for each of eight major LRUs and an additional fault indicator is on the 081 (Data Processor) to indicate the status of the 031 (Antenna).

QUALITATIVE FEATURES AND COMMENTS: (Continued)

problem could be the result of the technological level of the maintenance equipment. By comparison, contemporary fill drain system for similar oil cooled LRUs require about 15 minutes drain, purge, fill and recirculate oil.

- Case fasteners on the AN/APG-63 LRUs frequently break. Repair of the fasteners, while technically simple, is not authorized at the intermediate level. Since an LRU cannot be considered operationally ready with a broken fastener, there are times when an otherwise operational LRU is returned to the depot just for fastener replacement.
- Organizational maintenance personnel indicated that there is some BIT inconsistency. It is sometimes difficult to verify inflight BIT failures under ground power conditions or to obtain consistent BIT indications.
- In the AN/APG-63, 'birds' are spurious frequencies that are detected by the radar and displayed as a series of false targets. Accurate resolution of problems associated with 'birds' is dependent upon detailed information regarding radar operational mode and 'bird' display pattern(s). A more technically accurate method of troubleshooting is desired.
- There is insufficient organizational AGE to support maintenance (primarily electrical power and cooling air units), resulting in delays in performing required maintenance.
- Disassembly of the LVPS (610) is a problem. A potentially dangerous situation exists when removing certain seals due to the presence of pressurized nitrogen.
- Screw-on coaxial connectors on the Receiver (022) are difficult to remove/replace due to size and location. Plug-in type connector would be preferred.
- Pin replacement in connectors is difficult. Pin insertion/extractor tools malfunction (break) after 1-3 uses.
- Moisture problems exist with the waveguide providing RF to the missiles station from the radar. The problem is associated with the water separator.
- An improvement to BIT would be to provide a low power level output (through dummy load) to check the range and angle tracking functions.
- From a maintainability viewpoint, technicians prefer the radome mounting bolt design used on the F-4E for opening and closing the radome rather than the design of the F-15. Access to the F-15 radome mounting bolts is through the inside of the forward equipment bay doors.

DESIGN-FOR-REPAIR CONCEPT DEFINITION

CONTINUATION PAGE

DATE: 19 October 1978

QUALITATIVE FEATURES AND COMMENTS: (Continued)

- In the case of the AN/APG-63, the radar technicians would prefer to service the coolant system to the transmitter rather than the FCS (environmental control) personnel. This causes delays in producing an OR system.

DESIGN-FOR-REPAIR CONCEPT DEFINITION

**MAINTENANCE DATA COLLECTION DOCUMENTATION
& FEEDBACK SYSTEM**

DATE: 19 October 1978

GENERAL DESCRIPTION:

The maintenance data collection is in accordance with the procedure of AFM 66-1.

IMPLEMENTED METHODS:

Data are collected on the AFTO 349 and 350 form. The data are keypunched from the AFTO 349 and 350 and processed to the applicable ALC maintenance data activity.

METHOD(S) EFFECTIVENESS:

Constant review and analysis is performed. The feedback information provided has been effective but is dependent upon the need for a qualified analysis.

COMMENTS:

Flightline maintenance personnel do not maintain avionics history log by aircraft tail number which describes the malfunction and corrective action. Additionally failure trend analysis are performed by on-site contractor representatives which has proven to be most useful.

DESIGN-FOR-REPAIR CONCEPT DEFINITION

MAINTENANCE ORGANIZATION

DATE: 19 October 1978

GENERAL DESCRIPTION:

Maintenance organization is in accordance with AFR 66-5.

MAINTENANCE ORGANIZATION FLOW CHART:

The maintenance activities for the AN/APG-63 are part of the Aircraft Generation Squadron for organizational level maintenance and the Component Repair Squadron for intermediate level maintenance. See attached charts.

DESIGN-FOR-REPAIR CONCEPT DEFINITION

CONTINUATION PAGE

DATE: 19 October 1978

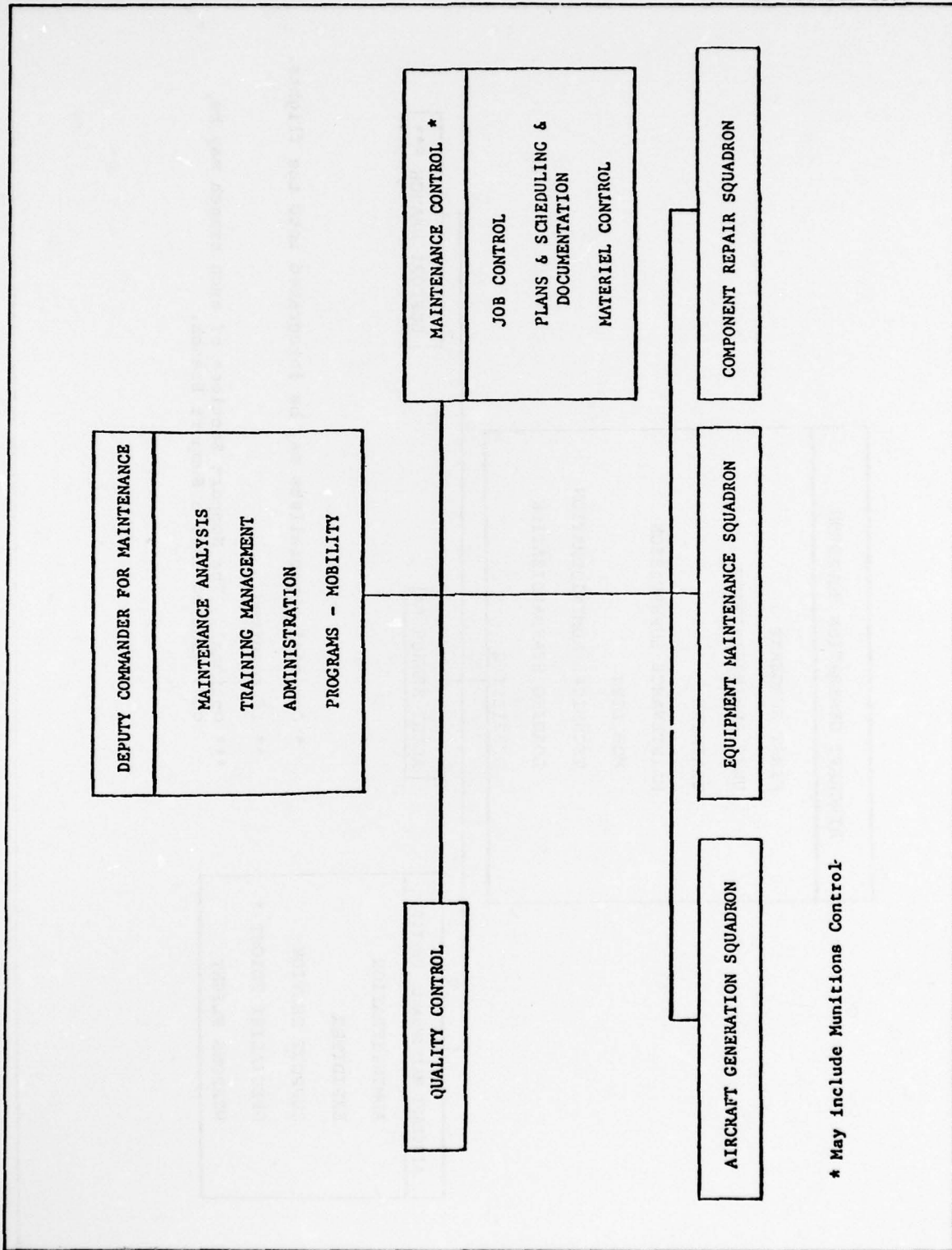

DESIGN-FOR-REPAIR CONCEPT DEFINITION

CONTINUATION PAGE

DATE: 19 October 1978

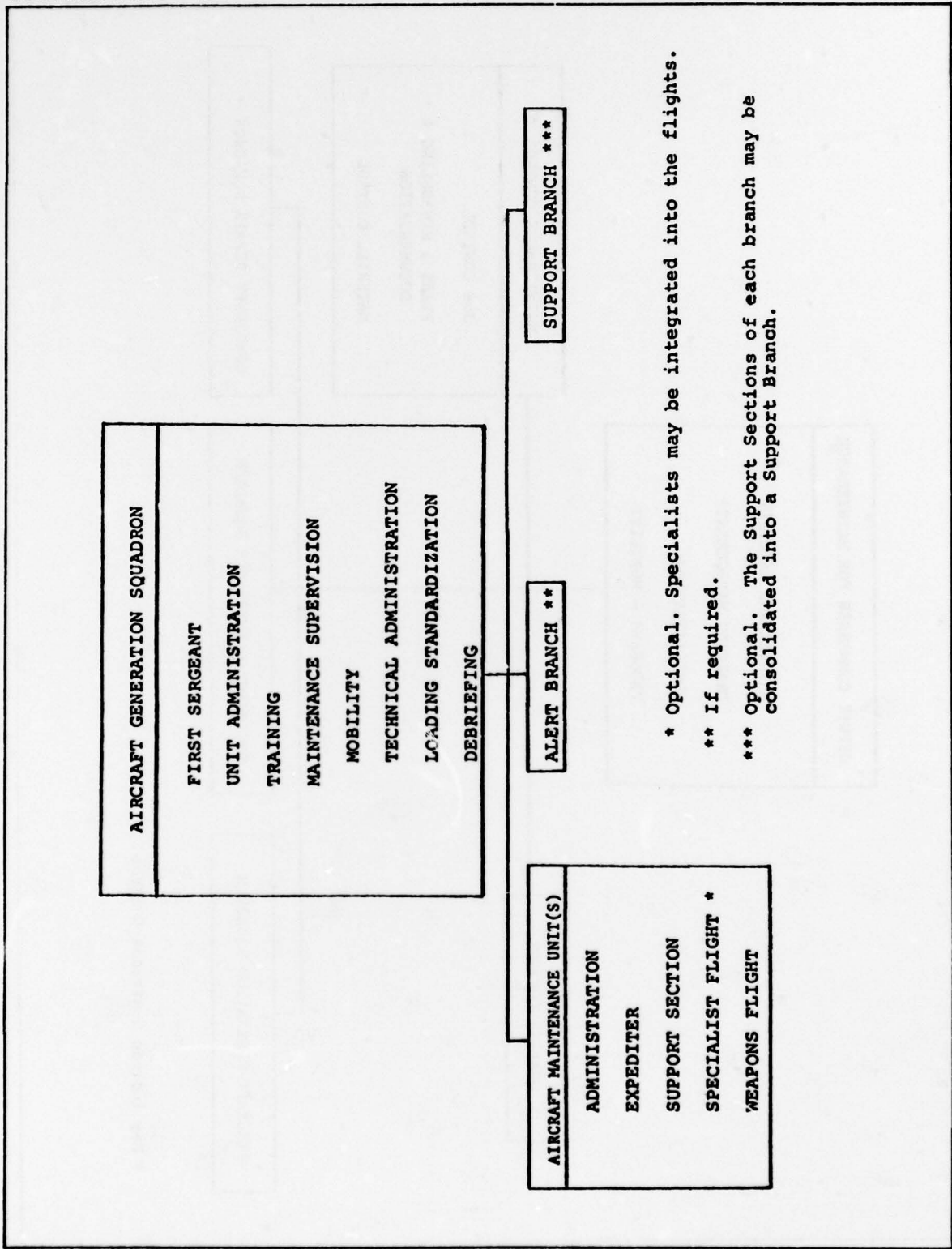

DESIGN-FOR-REPAIR CONCEPT DEFINITION

CONTINUATION PAGE

DATE: 19 October 1978

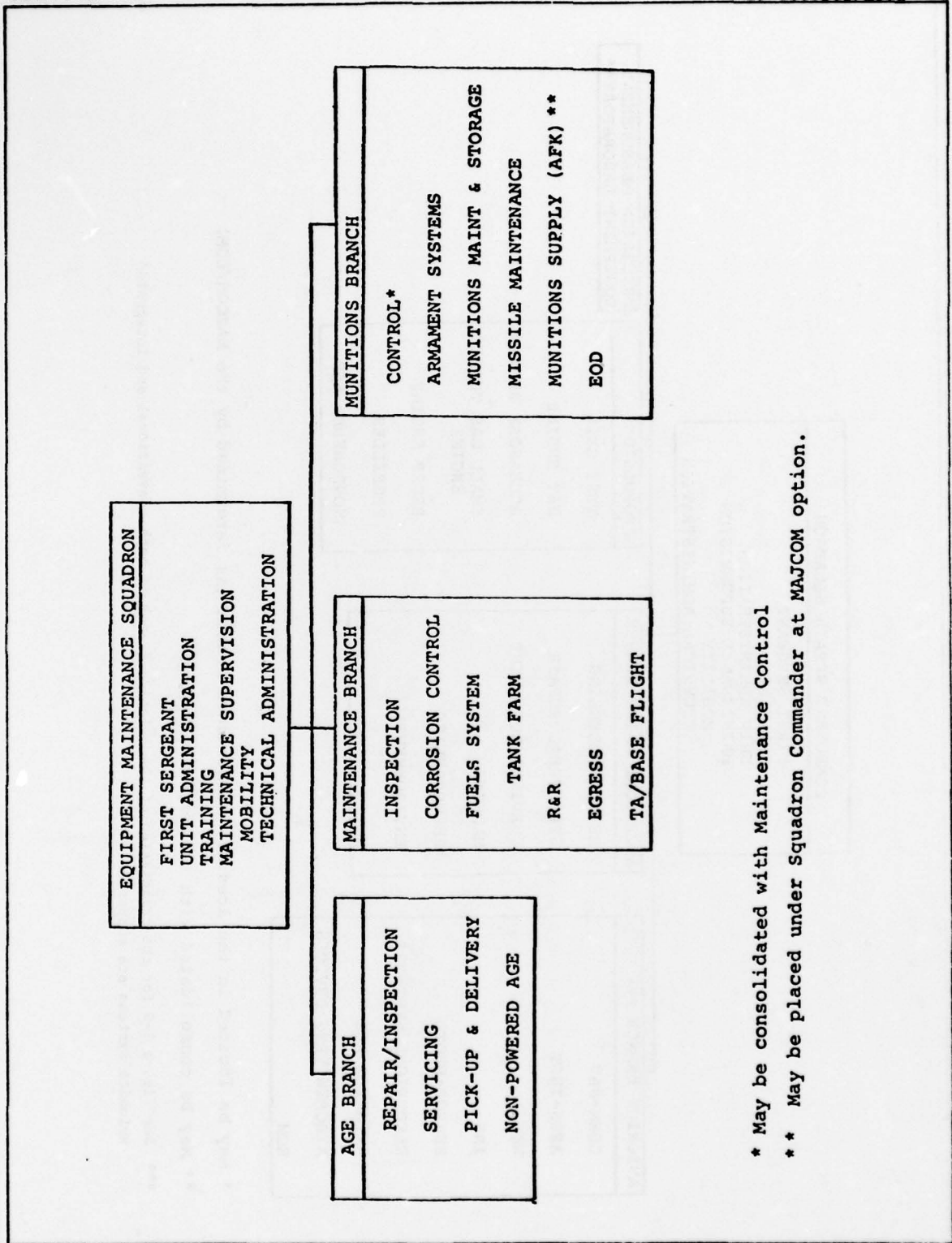

* May be consolidated with Maintenance Control
 ** May be placed under Squadron Commander at MAJCOM option.

DESIGN-FOR-REPAIR CONCEPT DEFINITION

CONTINUATION PAGE

DATE: 19 October 1978

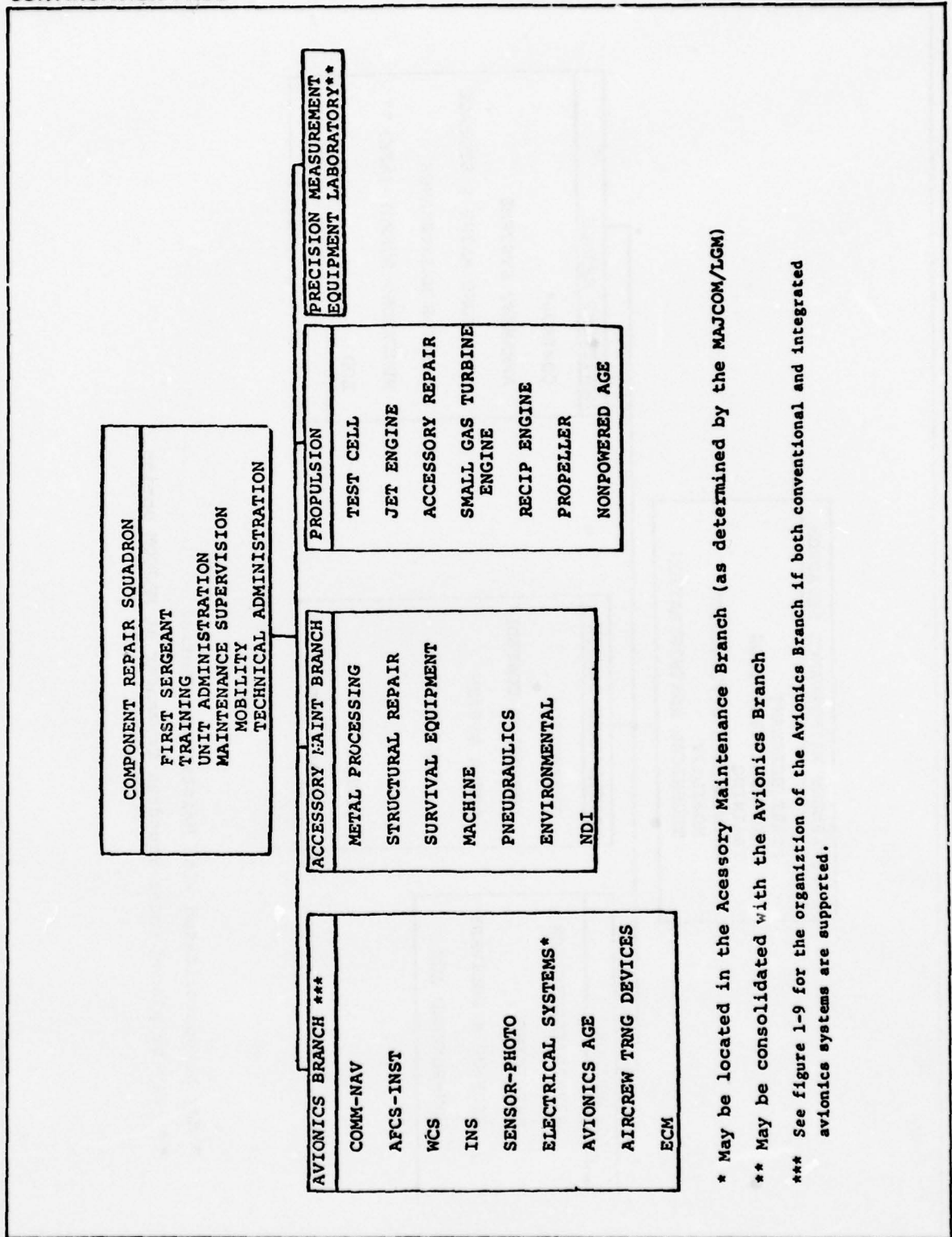

* May be located in the Accessory Maintenance Branch (as determined by the MAJCOM/LGM)

** May be consolidated with the Avionics Branch

*** See figure 1-9 for the organization of the Avionics Branch if both conventional and integrated avionics systems are supported.

DESIGN-FOR-REPAIR CONCEPT DEFINITION

ORGANIZATIONAL LEVEL AGE

DATE: 19 October 1978

DESCRIPTION OF AGE:

Electrical Power Unit

Cooling Air Unit

Antenna (031): See attached figure 5-6 of T.O. 1F-15A-2-25

Transmitter (011): See attached figure 5-7 of T.O. 1F-15A-2-25

PURPOSE OF AGE:

Power and Air: Troubleshooting AN/APG-63 when system must be powered (i.e. BIT)

Antenna AGE: Removal, protection, replacement of antenna

Transmitter AGE: Removal, protection, replacement of transmitter

COMMENTS:

- In actual practice, maintenance personnel will use AGE only when absolutely necessary.
- Power and air are always used when needed
- Antenna AGE are reportedly always utilized
- Transmitter AGE are almost never used. Personnel consider it to be cumbersome and time consuming to set up and use. Generally, two maintenance personnel will use a work stand to reach the XMTR and manually remove/replace it. The AGE is used only for demonstration or when the proximity of higher authority necessitates procedural prudence.

DESIGN-FOR-REPAIR CONCEPT DEFINITION

CONTINUATION PAGE

DATE: 19 October 1978

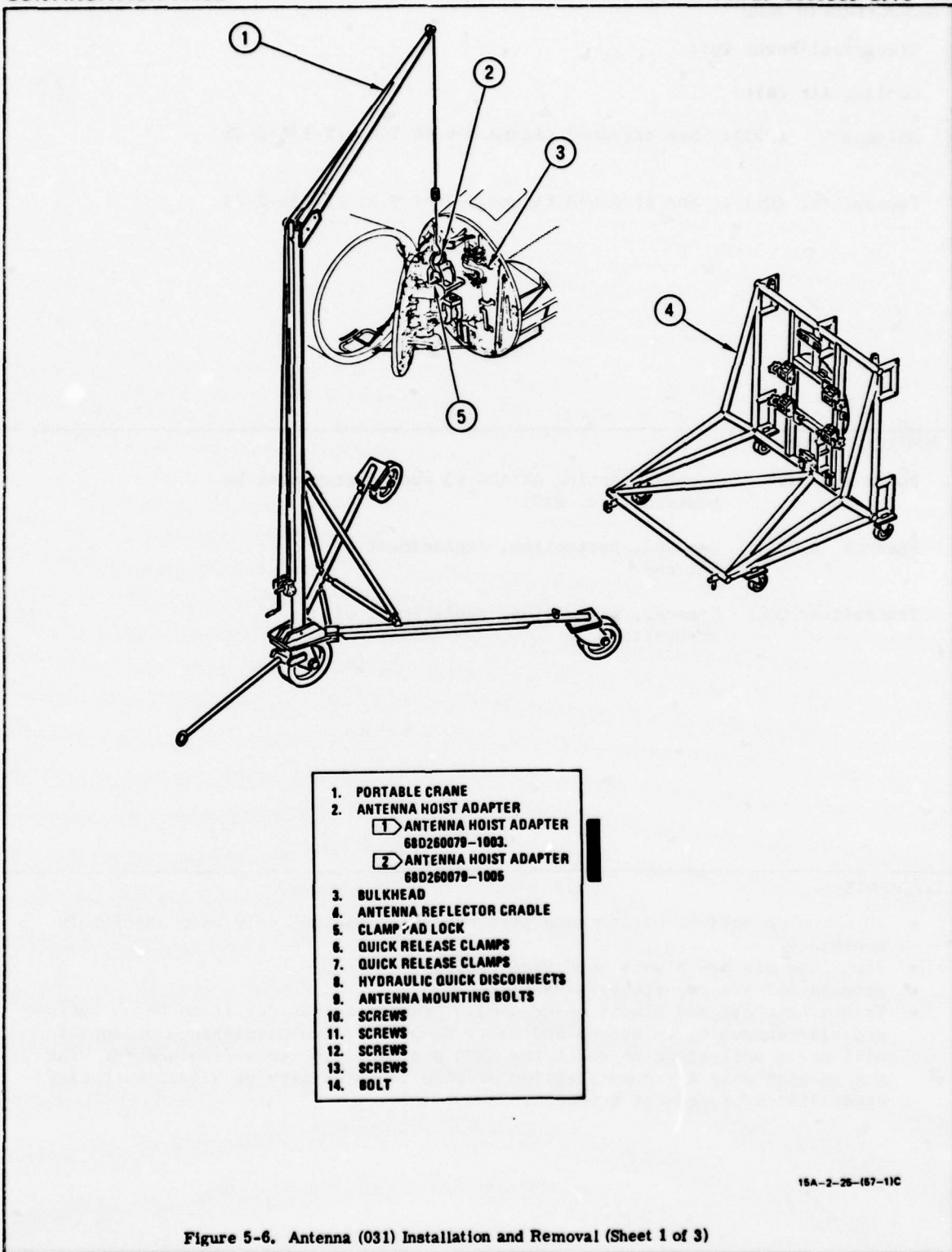

DESIGN-FOR-REPAIR CONCEPT DEFINITION

CONTINUATION PAGE

DATE: 19 October 1978

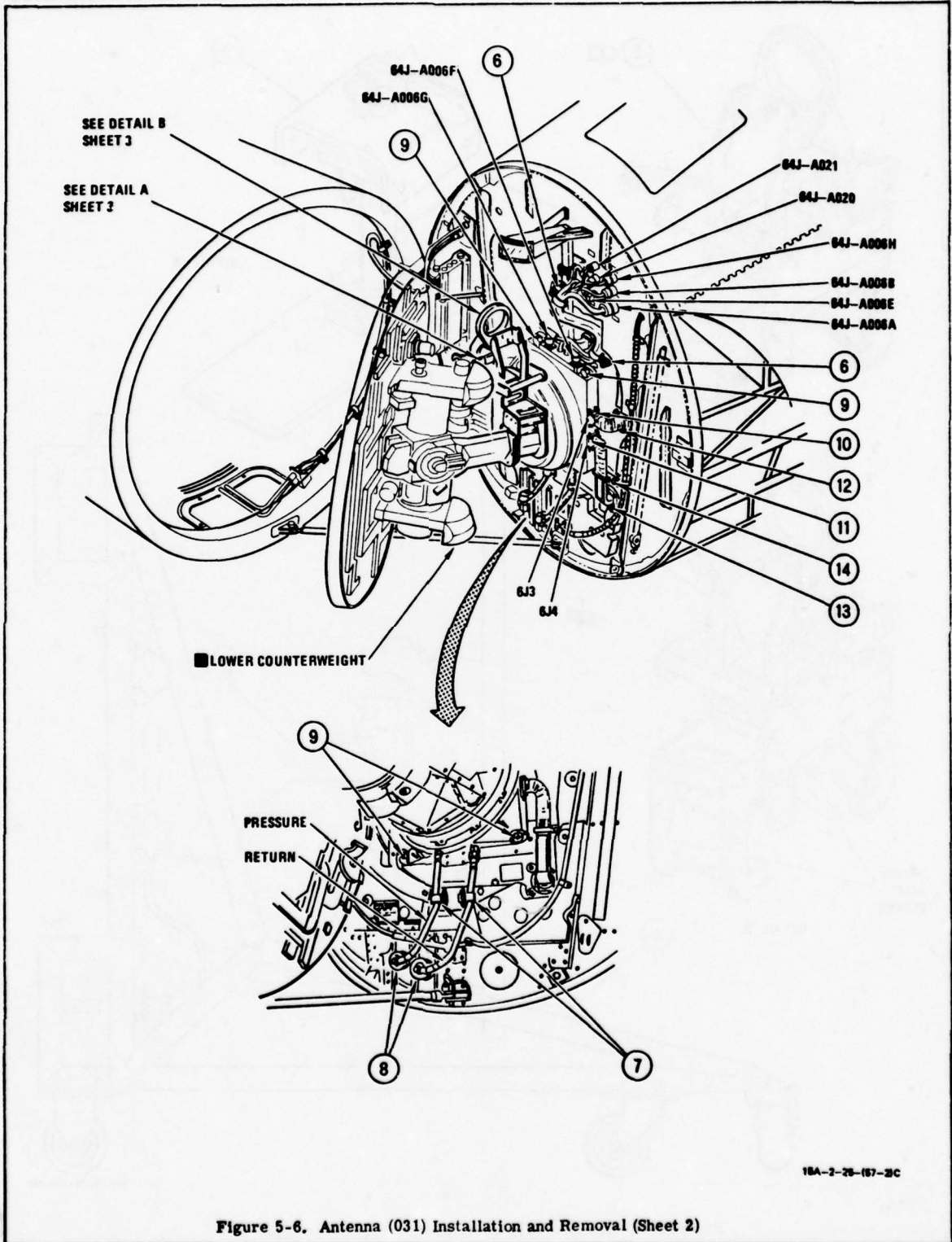

Figure 5-6. Antenna (031) Installation and Removal (Sheet 2)

DESIGN-FOR-REPAIR CONCEPT DEFINITION

CONTINUATION PAGE

DATE: 19 October 1978

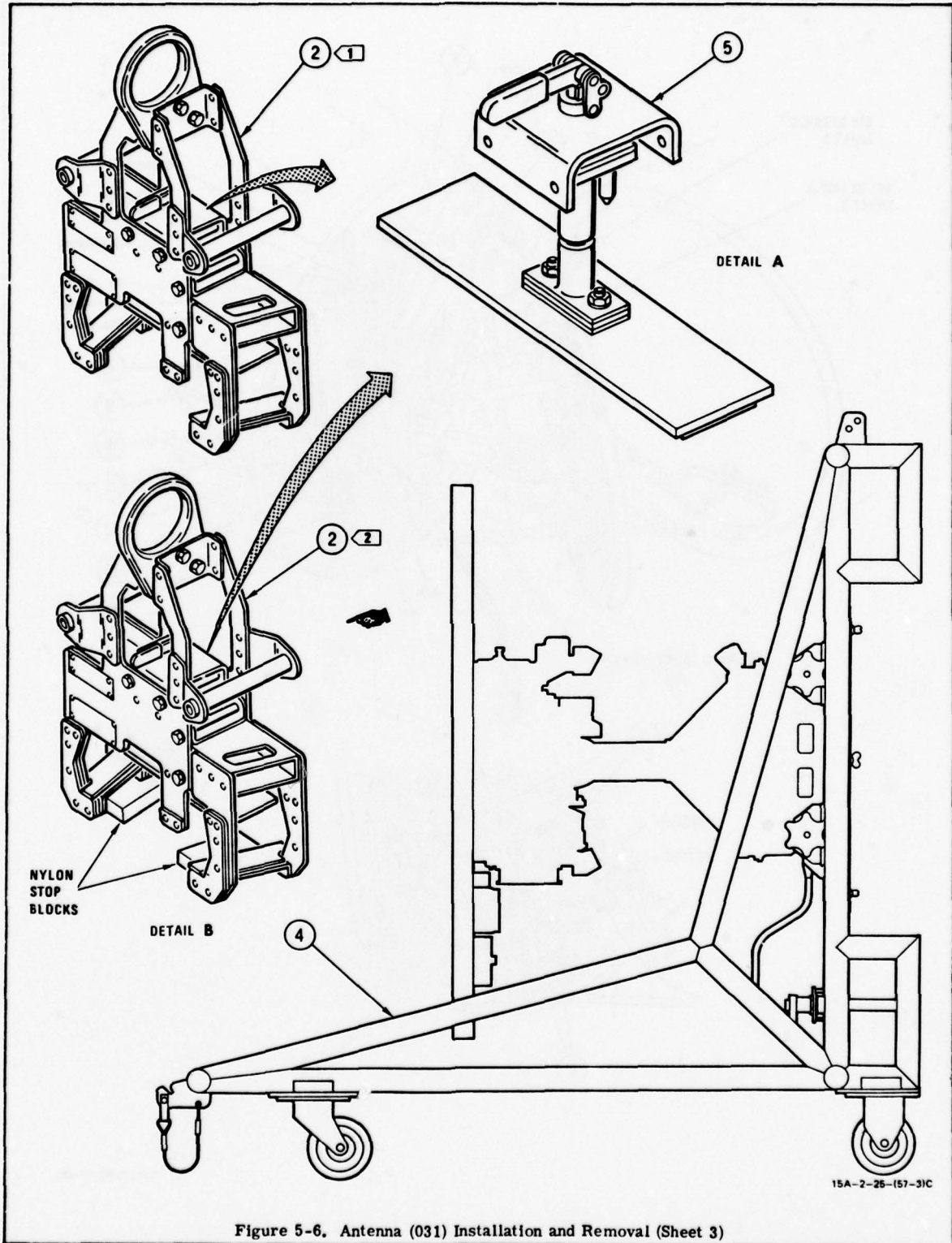
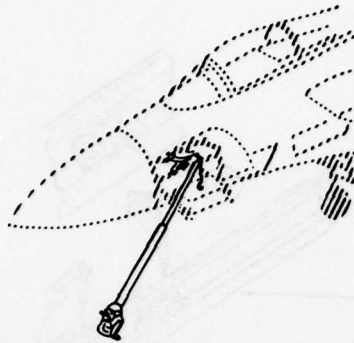

Figure 5-6. Antenna (031) Installation and Removal (Sheet 3)

DESIGN-FOR-REPAIR CONCEPT DEFINITION

CONTINUATION PAGE

DATE: 19 October 1978



LEGEND

- 1 SLIDE, EXTENSION - RADAR TRANSMITTER
68D260076-1001.
- 2 SLIDE, EXTENSION - RADAR TRANSMITTER
68D260076-1003.

- 1 MOVABLE SLIDE RAILS
- 2 ATTACHING SCREW
- 3 FRONT CONNECTOR BAR
- 4 LOCK PINS
- 5 STATIONARY ARMS
- 6 LOCK PINS
- 7 PIVOT ARM
- 8 LOCK PIN
- 9 HOOD LOCK AND PIN
- 10 HOIST TO TRIPOD ADAPTER
- 11 HOIST ADAPTER HOLE
- 12 HOIST CABLE AND HOOK
- 13 HOISTING RING
- 14 WINCH
- 15 STORAGE STRAPS
- 16 TELESCOPING HOIST
- 17 RADAR TRANSMITTER HOISTING TRIPOD
- 18 STATIONARY SLIDE RAIL
- 19 RADAR TRANSMITTER HANDLING HOOD
- 20 TRANSMITTER EQUIPMENT SHELF
- 21 SLIDE MOUNTING FITTING LIP
- 22 SLIDE REAR LOCATOR FITTING
- 23 POWER SUPPLY (610)
- 24 SLIDE LOCK
- 25 LOCATOR/SHEAR P/N
- 26 TAB LATCH
- 27 TAB LATCH RELEASE RING
- 28 STORAGE CASE

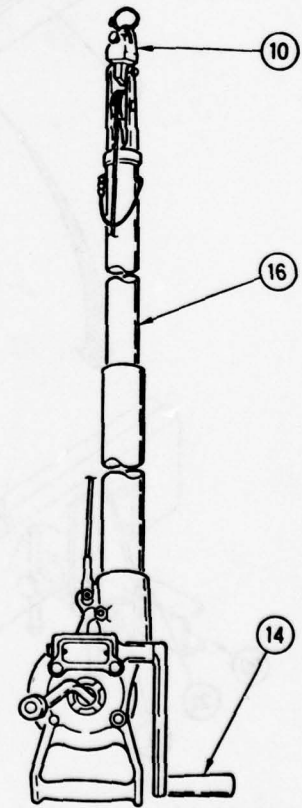
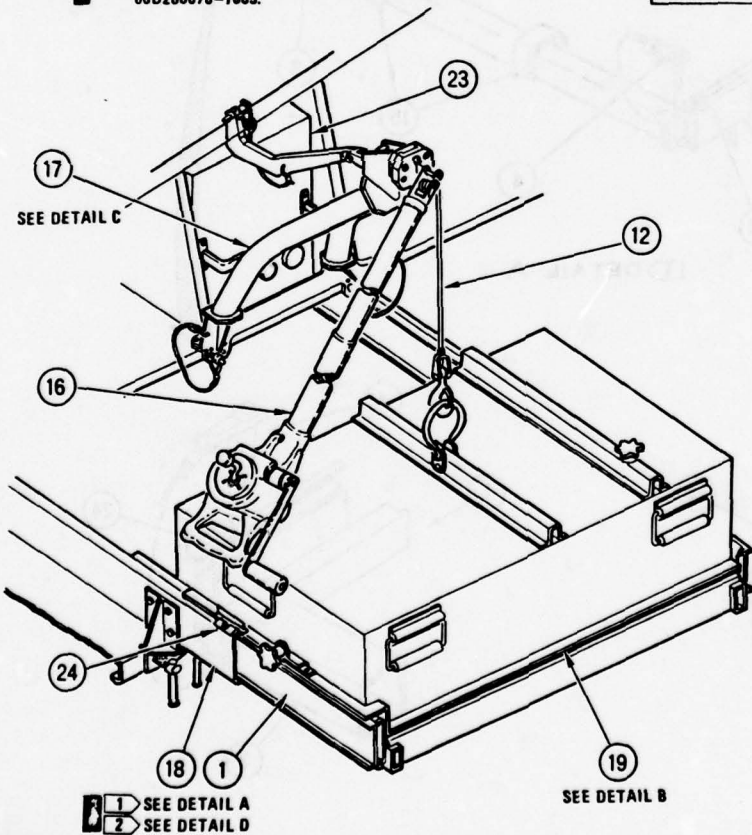

15A-2-26-(118-118)

Figure 5-7. Transmitter (011) Installation and Removal Special Tools (Sheet 1 of 4)

DESIGN-FOR-REPAIR CONCEPT DEFINITION

CONTINUATION PAGE

DATE: 19 October 1978

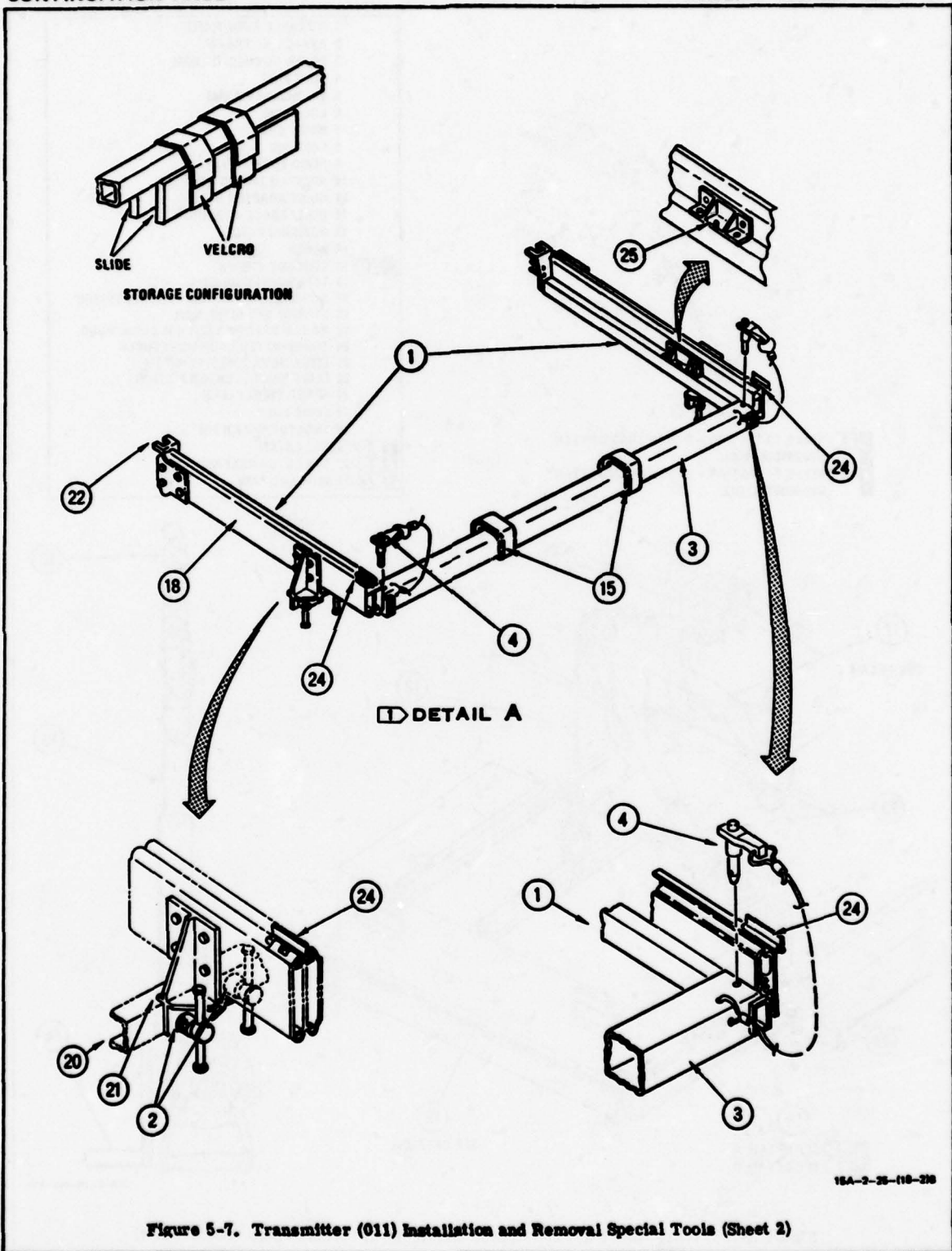

15A-2-25-118-218

Figure 5-7. Transmitter (011) Installation and Removal Special Tools (Sheet 2)

DESIGN-FOR-REPAIR CONCEPT DEFINITION

CONTINUATION PAGE

DATE: 19 October 1978

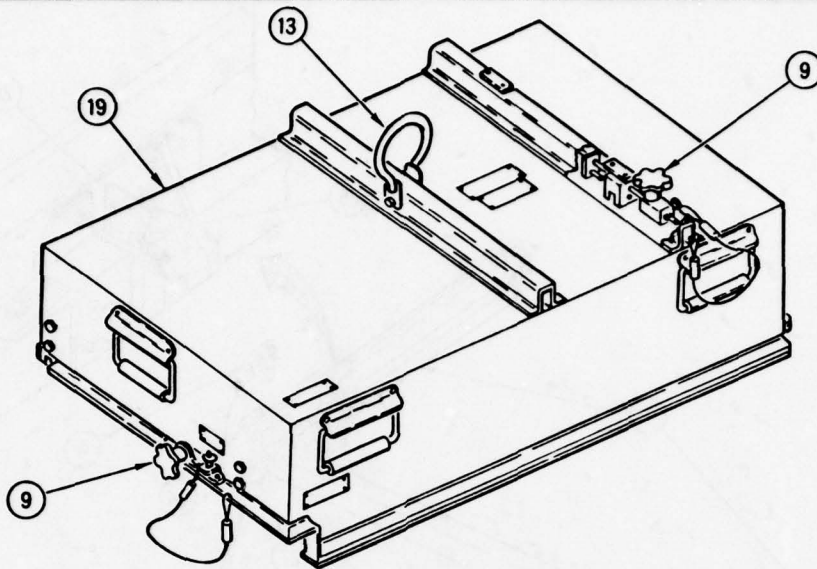

DETAIL B

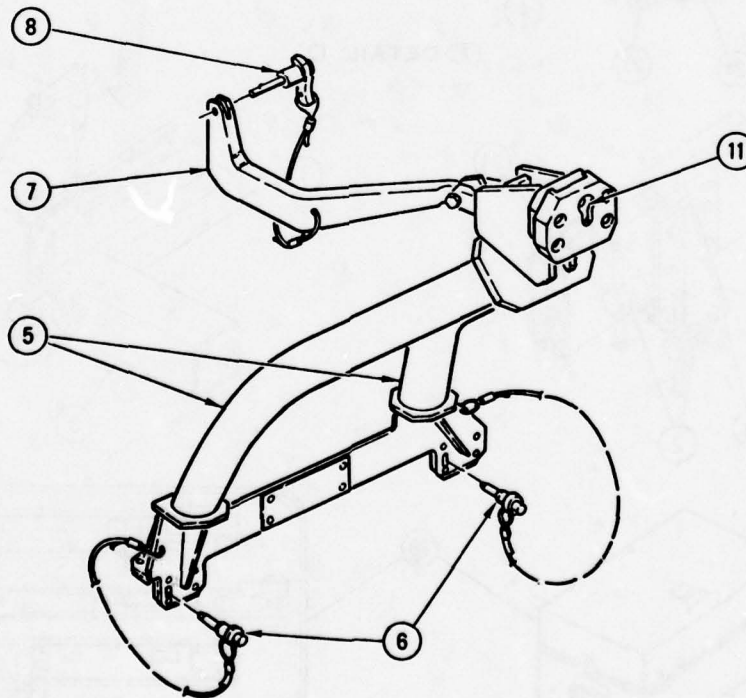

DETAIL C

Figure 5-7. Transmitter (011) Installation and Removal Special Tools (Sheet 3)

DESIGN-FOR-REPAIR CONCEPT DEFINITION

CONTINUATION PAGE

DATE: 19 October 1978

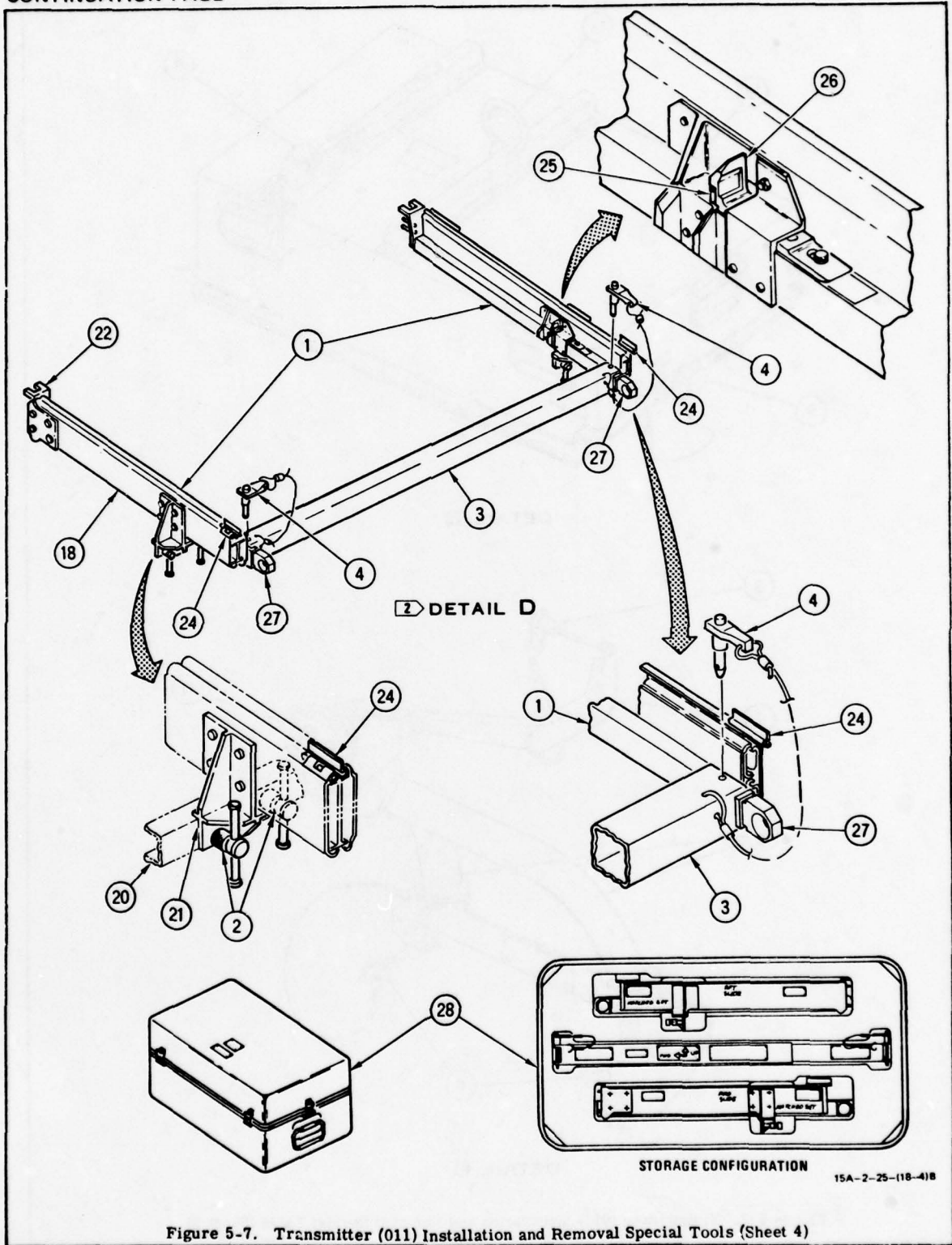

Figure 5-7. Transmitter (011) Installation and Removal Special Tools (Sheet 4)

DESIGN-FOR-REPAIR CONCEPT DEFINITION

PREVENTIVE MAINTENANCE

DATE: 19 October 1978

GENERAL DESCRIPTION:

None

PREVENTIVE MAINTENANCE REQUIREMENT SOURCE:

None

COMMENTS:

None

DESIGN-FOR-REPAIR CONCEPT DEFINITION

TECHNICAL ORDERS

DATE: 19 October 1978

DESCRIPTION OF TECH DATA REQUIREMENTS:

Organizational: IF-15A-2-2-1 (Basic maintenance information)
 IF-15A-2-2-3 (General maintenance procedures)
 IF-15A-2-25 (Radar system)

LRU	Intermediate		DEPOT
	TEST	REPAIR	OVERHAUL
Antenna (031)	12P2-2APG63-7-1	12P2-2APG63-2	12P2-2APG63-3
Receiver (022)	12P2-2APG63-18-1	12P2-2APG63-12	12P2-2APG63-13
Transmitter (011)	12P2-2APG63-27-1	12P2-2APG63-22	12P2-2APG63-23
Data Processor (081)	12P2-2APG63-38-1	12P2-2APG63-32	12P2-2APG63-33
Digital Processor (041)	12P2-2APG63-48-1	12P2-2APG63-42	12P2-2APG63-43
Analog Processor (039)	12P2-2APG63-58-1	12P2-2APG63-52	12P2-2APG63-53
Control Panel (541)	12P2-2APG63-67	12P2-2APG63-62	12P2-2APG63-63
RF Oscillator (001)	12P2-2APG63-78-1	12P2-2APG63-72	12P2-2APG63-73
Power Supply	12P2-2APG63-87	12P2-2APG63-82	12P2-2APG63-83

- - - -

IF-15A-12P2-2APG63-92: Field maintenance instruction (DEPOT)
 IF-15A-12P2-2APG63-94: Illustrated parts breakdown

DESCRIPTION OF TECH DATA FIELD DISCREPANCIES:

- Organizational maintenance personnel expressed a need for more detailed data on the operation of BIT. A more detailed understanding of BIT would enable personnel to better troubleshoot the system and discriminate between system failure and BIT failure.
- At the field level, technical orders provide detailed instructions on operating the test stations, but are of little use in finding faults not detected by the automatic testers. The technician has little flexibility in his interaction with the test station. The present concept is that schematics and definitive diagrams are not provided to aid the technician in troubleshooting. Moreover, the test station operators are not trained in the systems viewpoint of how different LRU's interact. Technicians are unhappy with this situation and would prefer schematics.
- Information regarding depot level mods which affect test specs are not forwarded to intermediate maintenance in a timely manner. Units are erroneously rejected at the intermediate level due to testing to the wrong specs.
- Intermediate level technicians do not feel that sufficient program documentation is provided for software, especially software changes. As a result it is difficult to determine exactly what circuitry is being tested.
- There is an absence of feedback from the depot on NRTS items. Intermediate level technicians would like to see this communication channel opened. Information on failures which they could not resolve could facilitate more accurate troubleshooting of like items.

DESIGN-FOR-REPAIR CONCEPT DEFINITION

CONTINUATION PAGE

DATE: 19 October 1978

DESCRIPTION OF TECH FIELD DISCREPANCIES: (Continued)

- There are reported inconsistencies between T.O. terminology and test stations.
- BIT MATRIX information (LRU BIT failure parameters) are not available to intermediate level technicians. Such data would facilitate more efficient troubleshooting.

DESIGN-FOR-REPAIR CONCEPT DEFINITION

TRAINING & PERSONNEL SKILLS LEVEL

DATE: 19 October 1978

DESCRIPTION OF SKILLS REQUIREMENTS:

The authorized skill requirements were not available, but it was indicated as being adequate to meet the maintenance concept. Experience on this system is the biggest asset in affecting an effective repair.

DESCRIPTION OF ASSIGNED SKILLS:

The organizational maintenance activity for avionics is in the Aircraft Generation Squadron and is adequately manned. The intermediate maintenance activity for avionics is in the Component Repair Squadron and manned at authorized levels.

GENERAL COMMENTS:

Basic training in electronics for unexperienced personnel needs to be expanded for the AN/APG-63; however, the system requires extensive OJT for a technician to become proficient. Cross-trainees from the computer maintenance field feel that their qualification exceed the requirements necessary to perform maintenance on the AN/APG-63 radar. The integration of the female technicians into the maintenance complex is wide spread and requires evaluation of the human factor aspects of the equipment/support system design.

DESIGN-FOR-REPAIR CONCEPT DEFINITION

TROUBLESHOOTING METHODS

DATE: 19 October 1978

DESCRIPTION OF ORGANIZATIONAL TROUBLESHOOTING METHODS:

- Visual checks of antenna operation and video output.
- Built in test (BIT) to identify faulty LRU. The BIT is 65-75% effective in confirming problem presence and isolation to a specific LRU.
- When local LRU spares become critical, a hot mock-up is provided using an aircraft with an operational AN/APG-63. In conjunction with intermediate maintenance personnel, the hot mock-up is used to screen and repair faulty LRU's.

DESCRIPTION OF INTERMEDIATE TROUBLESHOOTING METHODS:

- Visual checks of LRU and SRU's to identify obvious problems.
- Semi-automatic testing and manual probing to identify faulty SRU's.
- Use of a hot-mock-up as described above.

DESCRIPTION OF DEPOT TROUBLESHOOTING METHODS:

- Visual inspection of returned LRU's and SRU's.
- Functional testing of all returned LRU's to isolate failures to SRU level.
- Semi-automatic testing of SRU's.
- Manual probing to isolate faulty components.
- Functional testing of all repaired LRU's.

Note:

- Maintenance personnel find that TO's are adequate to perform required maintenance but it is sometimes cumbersome to trace necessary data through multiple TO's.
- ATE diagnosis are not fully developed. In cases where the ATE is effective, fault isolation to 3-10 discrete components is obtained.

**DESIGN-FOR-REPAIR CONCEPT DEFINITION
FIELD EVALUATION REPORT**

DATE: 13 November 1978

BASE: Seymour Johnson AFB(8-9 Nov. 1978)		WEAPON SYSTEM: F-4E	
PERSONNEL CONTACTED: Col. A. Anderson (Deputy Commander for Maintenance) Major T. Land (Component Repair Squadron Supervisor) MSGT T. Logan (NCOIC Photo/Sensor Shop) Mr. J. Dean (Unit Chief-Robins AFB) Mr. H. Perry (Line Chief-Robins AFB)			
SUBSYSTEM CATEGORY: Reconnaissance		WORK UNIT CODE: 71U00	
SUBSYSTEM NOMENCLATURE: Target Identification System Electro-Optical (TISEO)			
DESCRIPTION OF WEAPON SYSTEM MISSION: The F-4E assigned to the 4th TFW, which is a dual based wing, are assigned an air-to-surface weapons delivery mission. The dual basing concept requires annual deployments to Europe. The 4th also maintains a full mobility deployment capability.			
DESCRIPTION OF SUBSYSTEM CAPABILITIES: The TISEO provides visual identification of targets beyond range of the naked eye. TISEO is essentially a closed circuit television system with optical lock-on and tracking capabilities. Wide angle (spotting) and optically magnified narrow angle (precision) fields of view are provided.			
NUMBER OF LRUs PER SUBSYSTEM: 4			
LRU NOMENCLATURE/PART NUMBER: (See Continuation Sheet #1)			
WEAPON SYSTEM FLIGHT HOURS PER MONTH: 20		SUBSYSTEM FLIGHT HOURS PER MONTH: 20	
SUBSYSTEM GROUND OPERATING TIME PER FLIGHT HOUR: 0.33		EVALUATOR: J. Green M. Cochran	

DESIGN-FOR-REPAIR CONCEPT DEFINITION

CONTINUATION PAGE

DATE: 13 November 1978

LRU NOMENCLATURE/PART NUMBER: (continued from page #1)

LRU-1, Converter Stabilization Generator Group

OA-8585/ASX-1, P/Ns 301100, 301105, 301115

LRU-2, Video Processor SN-451/A5X-1, P/Ns 301600, 301601, 301700

LRU-3, Power Supply PP-6425/ASX-1, P/N 301800

LRU-4, TISEO Control C-8591/ASX-1, P/Ns 301900, 301500

INSPECTION REQUIREMENTS (-6):

- o Preflight, Inflight, and Postflight Inspections - tracker dome cover checks.
- o Special Inspections -
 - 1) Following LRU replacement, perform operational check.
 - 2) Following hard landing or excessive Gs, inspect power supply mounting security.
 - 3) When door 188 is opened, inspect power supply mounting security.

DESCRIPTION OF SUBSYSTEM DESIGN CHARACTERISTICS FOR MAINTENANCE:

TISEO is a modular system consisting of 4 major LRUs. Built-in-test equipment monitors operation of the video processor and power supply and, in conjunction with operational checks, operational status of the system can be determined in the cockpit.

DESCRIPTION OF SPECIAL MAINTENANCE AIDS OR LOCAL MODIFICATIONS:

None

MAINTENANCE CONCEPT - DESIGN:

- o Organizational Maintenance - cleaning, checkout, isolation of failures to the LRU, and LRU replacement.
- o Intermediate Maintenance - LRU testing and repair by replacement of an SRU (plug in components such as circuit boards).
- o Depot - LRU repair beyond "I" capability and SRU repair.

OPERATIONAL ENVIRONMENT

Tactical fighter/bomber squadrons deploy using the bare base concept. Operational concepts for tactical air forces requires a high degree of flexibility and mobility to attain proficiency in tactical operations. This capability must be established in the following areas:

- o Quick-reactions deployment and employment anywhere in the world under any combat conditions
- o Primary employment in limited war and special warfare operations
- o Normal employment as a component of a joint force
- o Operations of extended duration using a wide selection of weapons
- o Economical operation under any combat situation
- o Rapid transition from one type of warfare to another
- o Establish force increments of varying size and type for specialized missions

(See continuation sheet)

MAINTENANCE ENVIRONMENT

The tactical fighter squadron is organized and manned for organizational and field maintenance capability. Organizational level maintenance includes inspection, servicing, fault isolation, removal and replacement of components and system calibration. Servicing tasks encompass the loading and unloading of munitions. Field maintenance provides intermediate maintenance capability and is organized and capable of supporting the tactical squadrons. This capability is the same at the deployed base as at the home base and includes repair and testing of engines; local manufacture of parts; testing, calibration and repair of aircraft and aerospace ground equipment, assemblies and components; and inspection and repair which is beyond the capability of organizational level maintenance. In addition, a complete precision measurement equipment laboratory is available to support maintenance functions at home base and deployments to a Bare Base.

By necessity, a large portion of required maintenance, e.g., unscheduled/scheduled, must be accomplished during the hours of darkness in preparation for the next mission (sortie). Maintenance capability must exist regardless of the hour of the day or weather conditions. The flightline maintenance environment is far from

(See continuation sheet)

NATURAL ENVIRONMENT

Climatic conditions can range throughout the full spectrum of weather. During Bare Base operations, hostility requirements dictate that all operations will be conducted on a 24-hour day, 7-day week basis. The maintenance environment is subjected to extreme climatic variances due to rapid response deployment requirements. The amount of variance encountered relates directly to the degree of maintenance efficiency which may be expected and subsequently the effectiveness of the fighting unit.

Flight-line maintenance activities expose both men and equipment to the mercy of the elements. Maintenance is performed around the clock and personnel are exposed to further distraction from high noise levels. Shop maintenance conditions are superior to those experienced on the flightline; however, crowded conditions exist generating a continuing programmed requirement for 24 hour shift work.

(See continuation sheet)

DESIGN-FOR-REPAIR CONCEPT DEFINITION

CONTINUATION PAGE

DATE: 13 November 1978

OPERATIONAL ENVIRONMENT

At a Bare Base deployment site the environment is identified by austere facilities, unfamiliar and severe climatic conditions, the increased tempo of operations, and personal emotional and physical stress. These bases range in capability from advanced terminals such as Orly in Paris on one extreme to narrow, weed-grown strips in Chad in Africa on the other. In addition, there are numerous other bases, where facilities for personnel support and general housekeeping are adequate, but the maintenance equipment is not equal to current advanced aircraft weapons systems.

MAINTENANCE ENVIRONMENT

ideal. Flightline maintenance personnel are subjected to distractions of jet engines in operation, taxiing aircraft and jet blast. Use of handbooks and schematics normally associated with flightline maintenance is externally difficult for the reasons stated. Shop maintenance (intermediate maintenance) operations are more extensive than flightline maintenance functions. Even though work requirements may generate a need for around the clock operations and facilities are crowded, work is normally performed in some type of shelter, building, etc.

NATURAL ENVIRONMENT

Climatic conditions of high humidity indirectly affect performance of electronic equipment to some degree. Extreme temperature has a greater effect on maintenance personnel than on equipment. Extremes in temperature and humidity are directly related to the magnitude of the problems encountered and the solutions required to support immediate flight operations.

DESIGN-FOR-REPAIR CONCEPT DEFINITION

ACCESSIBILITY OF AVIONICS

DATE: 13 November 1978

GENERAL DESCRIPTION:

- o LRU-1 is located on leading edge of left wing and is easily removed (15 mins. estimate)
- o LRU-2 is located inside left wing leading edge between LRU-1 and fuselage. Removal of the unit is very difficult.
- o LRU-3 is located in fuselage behind panel 188 over left wing and is easily removed.
- o LRU-4 is located in rear cockpit left hand console and is easily removed.

QUANTITATIVE VALUES:

- o LRU-1 removal required removal of approximately 20 screws (a special driver is required)
- o LRU-3 access required removal of approximately 36 screws.
- o LRU-2 removal requires one hour and involves at least two other shop's support

DESCRIBE SUBSYSTEM REMOVAL:

- o LRU-4 is removed from the console by releasing four fasteners, lifting unit and disconnecting one connector.
- o LRU-3 is removed by opening an access door over the wing, disconnecting 2 connectors, and removing the mounting bolts.
- o LRU-1 is removed by taking off upper and lower covers, removing mounting bolts, disconnecting the connectors and sliding the unit out of its mounts.
- o LRU-2 is removed after LRU-1. Removal is hampered by poor accessibility, (wing leading edge flap must be lowered).

DESIGN-FOR-REPAIR CONCEPT DEFINITION

AGE OF SYSTEM & TECHNOLOGY

DATE: 13 November 1978

GENERAL DESCRIPTION:

The TISEO design evolved from requirements recognized during the early seventies. The equipment was retrofitted to F-4Es beginning in approximately 1977.

TYPE OF COMPONENTS USED:

- o Discrete solid-state components
- o Integrated circuits
- o Electro-mechanical components
- o Optical lens systems
- o Vidicon tubes

TYPE OF WIRING AND INTERFACE USED:

- o Wiring - bundles of multistrand and coaxial wiring interconnecting the LRUs
- o Interfaces - one to four quick-disconnect multi-pin connectors on each LRU. SRUs are plug-in modules (connector pins are fragile and are requiring some maintenance).

SYSTEM DESIGN APPROACH (ANALOG, DIGITAL, SOFTWARE, ETC.):

Analog signal processing is used throughout this system.

DESIGN-FOR-REPAIR CONCEPT DEFINITION

DEBRIEFING

DATE: 13 November 1978

DESCRIPTION OF THE DEBRIEFING FUNCTION:

The debriefing function operates independently of the AGS flightline maintenance organization which maintains the TISEO systems in the F-4Es. The TISEO system status is indicated by the aircrew at the time of weapon system debriefing by appropriate entries in the aircraft forms.

DESCRIBE THE DEBRIEFING PROCEDURE:

- o Aircrew determines operational status of the system
- o Aircrew enters TISEO discrepancies in the aircraft forms (781s).
- o Debriefing enters relays TISEO discrepancies to maintenance control.
- o Maintenance control notifies the AGS flightline maintenance organization of the TISEO discrepancies.

DESCRIBE DATA FLOW AND RECORDS:

- o Aircrew enters discrepancies in the 781s
- o Debriefing records the discrepancies on TAC Form 93s.
- o Organizational, intermediate and depot maintenance is recorded on AFTO 349s.

DESIGN-FOR-REPAIR CONCEPT DEFINITION

DEPOT SUPPORT

DATE: 13 November 1978

DESCRIPTION OF DEPOT SUPPORT SCOPE:

SRUs from LRU-1 and LRU-2 are sent to the depot for repair. Also, when a malfunction is isolated to the sealed forward section of LRU-1, the complete SRU is sent to the depot shop for repair. Depot support is accomplished by Warner Robins ALC.

DEPOT SUPPORT EFFECTIVENESS:

LRUs received from depot are functionally tested and normally are found to require alignments. Experience at Seymour Johnson AFB indicates that these units will cause writeups if not aligned prior to aircraft installation.

COMMENTS:

Spare LRUs have not been available when required. F-4Es are grounded when LRU-1's are being procured to utilize in the aircraft when no replacement is available.

DESIGN-FOR-REPAIR CONCEPT DEFINITION

(PRE, IN, POST) -FLIGHT INSPECTION

DATE: 13 November 1978

DESCRIPTION OF THE INSPECTIONS:

- o Pre, through postflight-ground crew verifies removal/installation of the TISEO optical window cover.
- o Preflight/inflight-aircrew perform operational check of the TISEO system.

FREQUENCY OF INSPECTIONS:

Inspections of the TISEO system are performed prior to, during and following each F-4E sortie which is flown.

PURPOSE OF INSPECTIONS:

Inspections of the TISEO system are accomplished each sortie to verify removal/installation of the window cover and operational status of the system.

COMMENTS:

Operational checks of the TISEO system are accomplished by aircrews as part of sorties flown during daylight hours. Operation of the TISEO in low light or darkness conditions will cause damage to the system.

DESIGN-FOR-REPAIR CONCEPT DEFINITION

LEVEL OF BASE REPAIR

DATE: 13 November 1978

DESCRIPTION OF ORGANIZATIONAL REPAIR:

1. UNSCHEDULED:

Remove/replace LRU

2. SCHEDULED:

Operational check every 180 days

DESCRIPTION OF INTERMEDIATE REPAIR:

1. UNSCHEDULED:

- o Remove/replace SRU
- o Repair wiring or remove/replace piece part where authorized by the -6.

2. SCHEDULED:

None

DESCRIPTION OF DEPOT REPAIR:

1. UNSCHEDULED:

- o Repair SRUs from LRU-1 and LRU-2
- o Repair LRUs requiring maintenance beyond intermediate shop capabilities

2. SCHEDULED:

None

DESIGN-FOR-REPAIR CONCEPT DEFINITION

MAINTAINABILITY CHARACTERISTICS OF EQUIPMENT DESIGN

DATE: 12 November 1978

GENERAL DESCRIPTION OF SUBSYSTEM FEATURES:

The TISEO system is modularized into the LRUs. The TISEO system includes built-in-test equipment which monitors status of several system functions and provides a fail indication on the TISEO control unit in the rear cockpit. The control unit is equipped with a test connector for analysis of a failure indication.

QUANTITATIVE VALUES:

- | | | |
|---|---|---|
| (1) MTBF - 80 Hours | (2) MTBM - 6.4 Hours @
Organizational Level | (3) MMH/FH - 1.03 Combined
Organizational & Inter-
mediate Levels |
| (4) MTTR - 2.3 Hours Organizational Level
2.5 Hours Intermediate Level | (5) MTBD - 13.9 Hours @ Organiza-
tional Level | |

All values are from AFM 66-1 data.

QUALITATIVE FEATURES:

The TISEO system exhibits a low failure rate (not one of the aircraft top ten). Most TISEO failures are caused by two LRUs (CSGG and video processor). Failures are divided equally between these two LRUs, however, the CSGG is always checked first because the video processor, due to accessibility problems, is difficult to remove from the aircraft.

COMMENTS:

- 1) Control unit test connector provides for fault-isolation of a fail indication to one of four possible faults. Special test equipment is required to determine the fault.
- 2) Fault-isolation of the system using the interface test set provided is difficult or impossible due to limited access provided thru access door 189 to the video processor connectors.

DESIGN-FOR-REPAIR CONCEPT DEFINITION

MAINTENANCE DATA COLLECTION DOCUMENTATION & FEEDBACK SYSTEM

DATE: 13 November 1978

GENERAL DESCRIPTION:

The maintenance data collection is in accordance with the procedures of AFR 66-5 and AFM 66-1.

IMPLEMENTED METHODS:

Maintenance data is collected on the AFTO 349 form. The data are keypunched from the AFTO 349 and processed. The 4th TFW analysis section generates reports on system utilization, reliability, man-hour consumption, etc.

METHOD(S) EFFECTIVENESS:

The system is effective, however, since the TISEO is not a high failure system, analysis of TISEO discrepancies is not extensive.

COMMENTS:

A TISEO 180 hour inspection of the TISEO is accomplished by the 4th TFW. Supposedly this reduces in-flight discrepancies, however, no data analysis has been conducted to ascertain the validity of this claim.

DESIGN-FOR-REPAIR CONCEPT DEFINITION

MAINTENANCE ORGANIZATION

DATE: 13 November 1978

GENERAL DESCRIPTION:

The maintenance organization is in accordance with AFR 66-5.

MAINTENANCE ORGANIZATION FLOW CHART:

The maintenance activities for the TIESO are part of the aircraft generation squadron for organizational level maintenance and component repair squadron for intermediate level maintenance.

(See Attached Charts)

DESIGN-FOR-REPAIR CONCEPT DEFINITION

CONTINUATION PAGE

DATE: 13 November 1978

MAINTENANCE ORGANIZATION FLOW CHART:

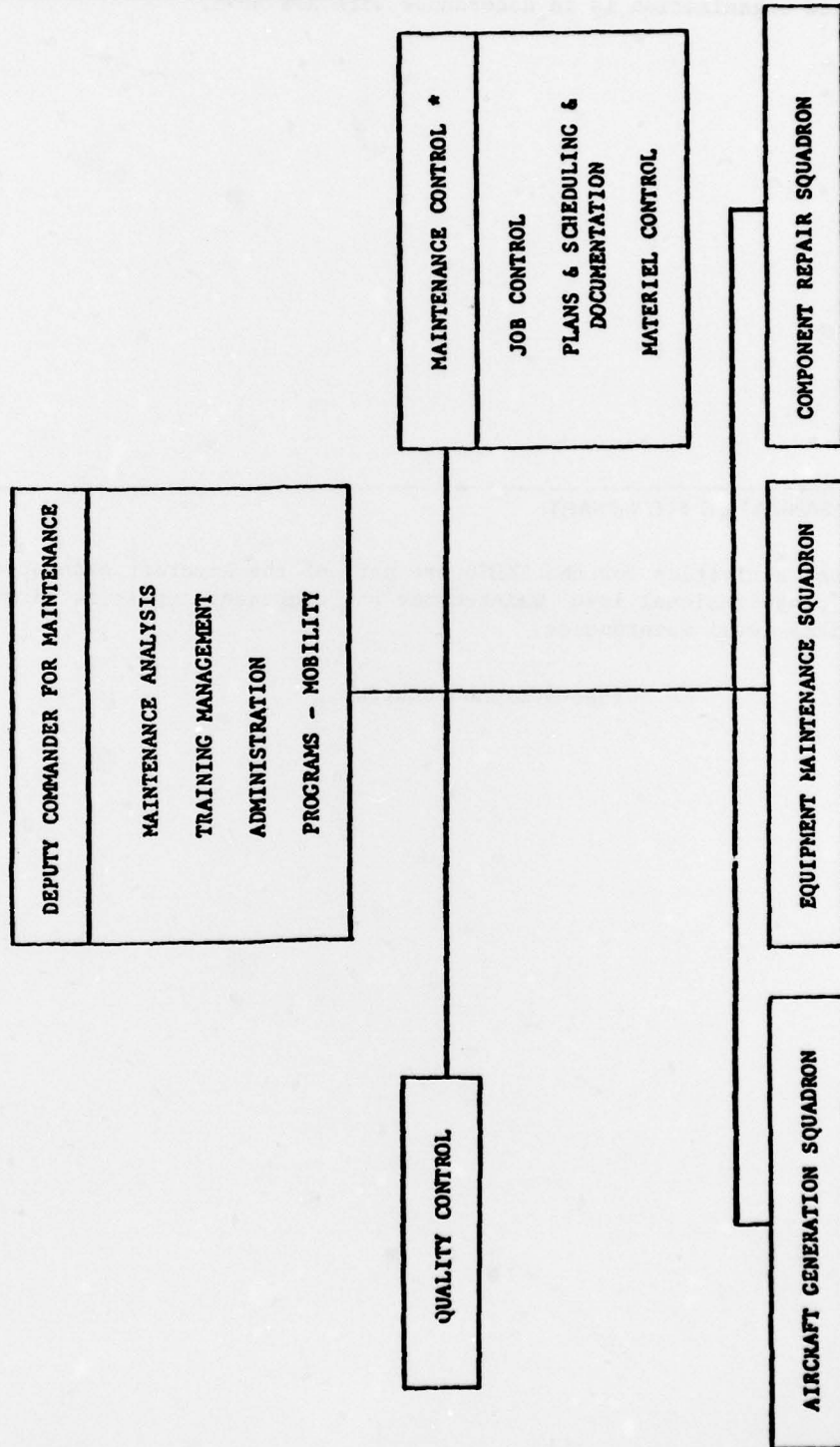

* May include Munitions Control

DESIGN-FOR-REPAIR CONCEPT DEFINITION

CONTINUATION PAGE

DATE: 13 November 1978

MAINTENANCE ORGANIZATION FLOW CHART:

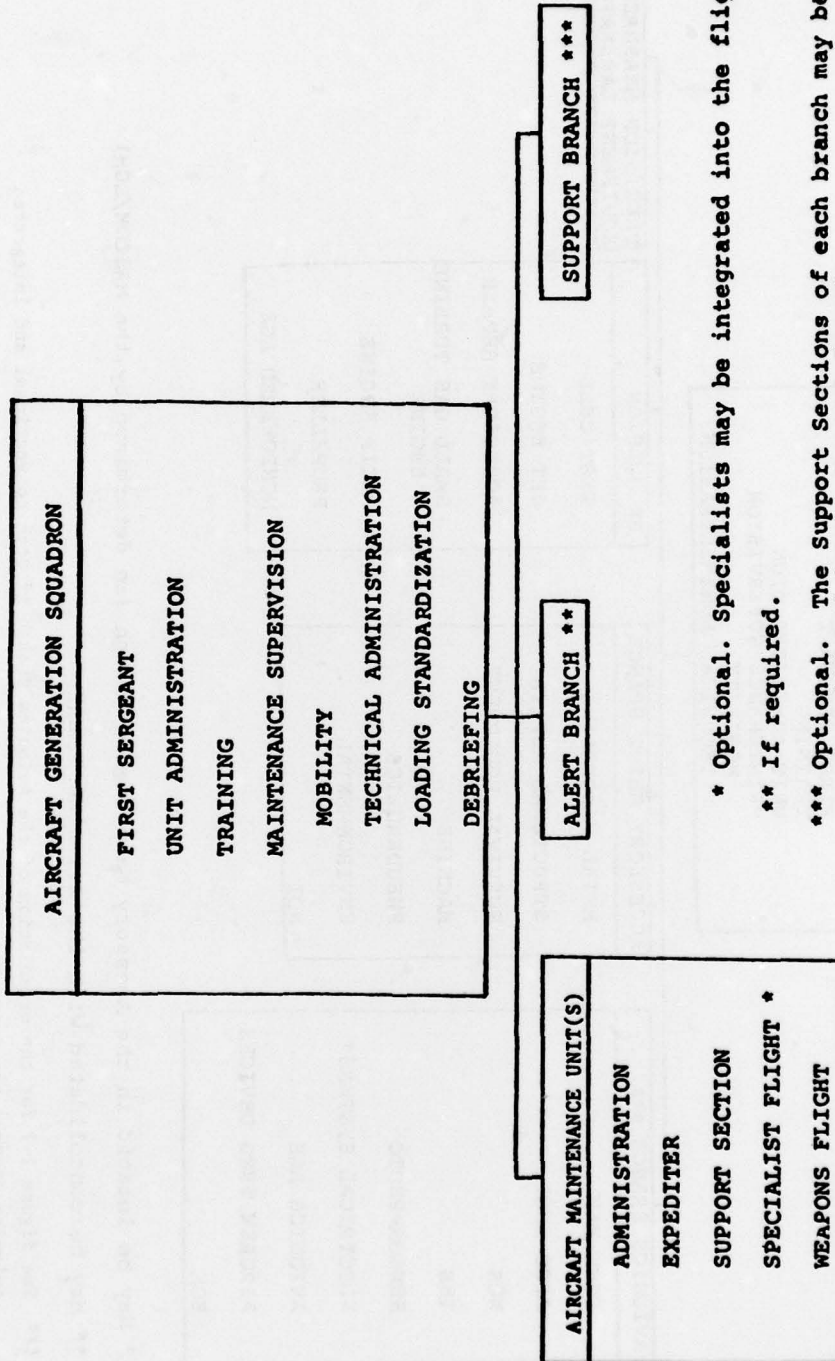

* Optional. Specialists may be integrated into the flights.

** If required.

*** Optional. The Support Sections of each branch may be consolidated into a Support Branch.

DESIGN-FOR-REPAIR CONCEPT DEFINITION

CONTINUATION PAGE

DATE: 13 November 1978

MAINTENANCE ORG.
FLOW CHART:

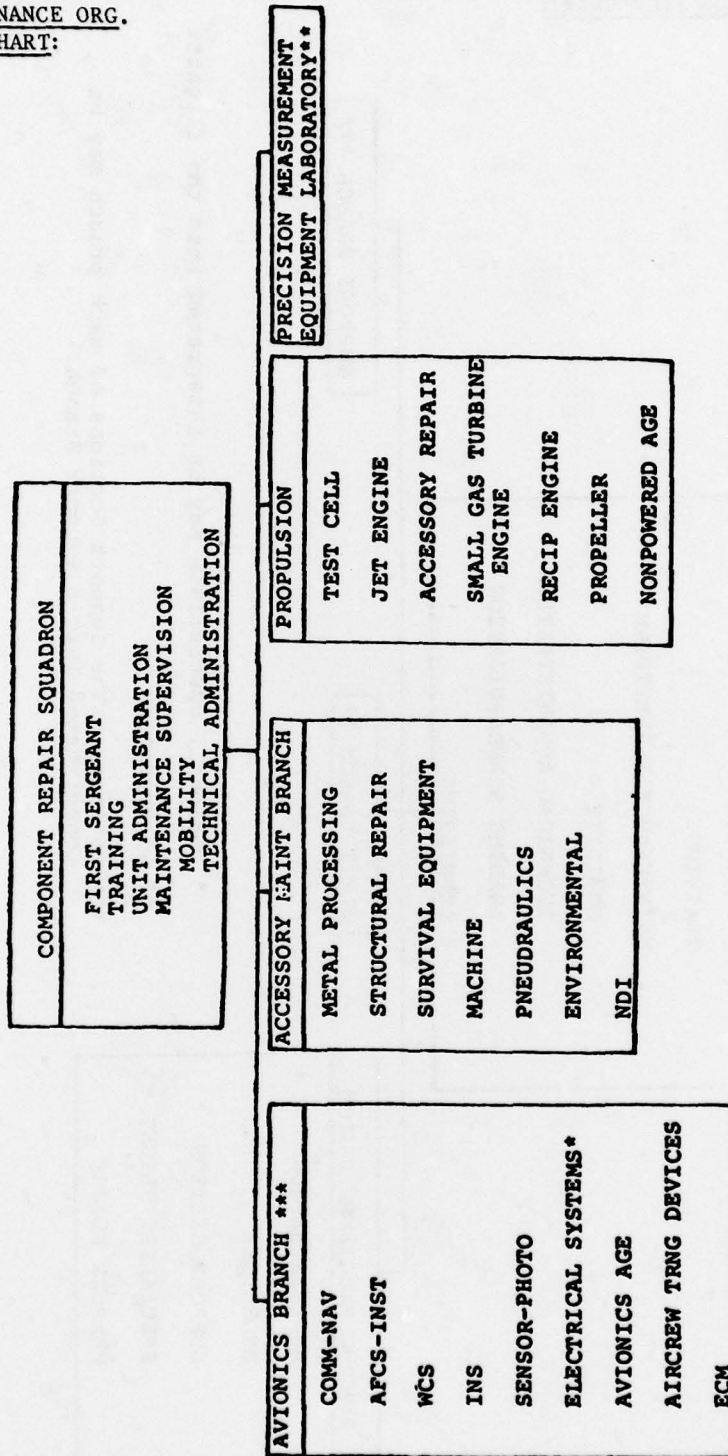

* May be located in the Accessory Maintenance Branch (as determined by the MAJCOM/LGM)

** May be consolidated with the Avionics Branch

*** See figure 1-9 for the organization of the Avionics Branch if both conventional and integrated avionics systems are supported.

DESIGN-FOR-REPAIR CONCEPT DEFINITION

CONTINUATION PAGE

DATE: 13 November 1978

MAINTENANCE ORGANIZATION FLOW CHART:

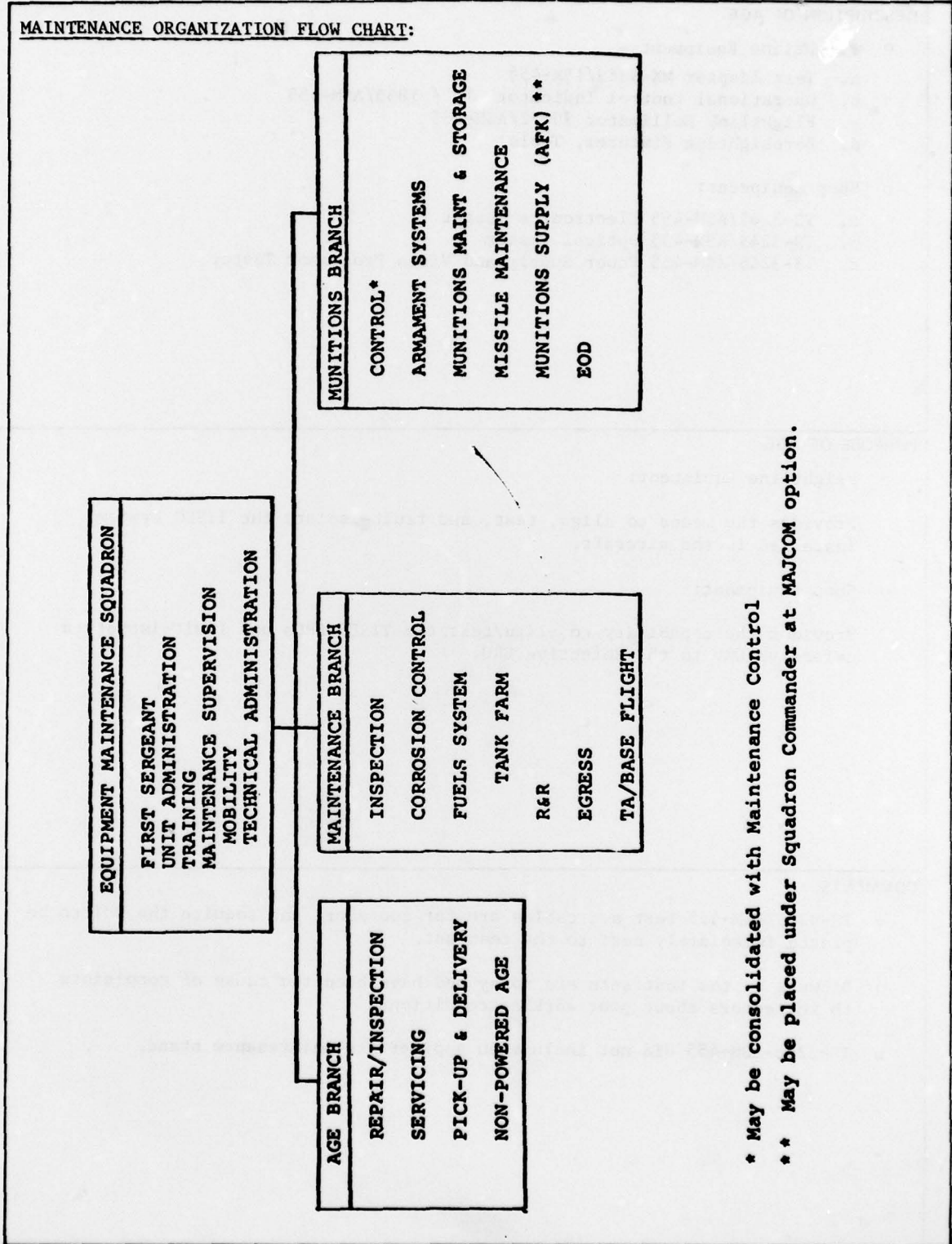

* May be consolidated with Maintenance Control

** May be placed under Squadron Commander at MAJCOM option.

DESIGN-FOR-REPAIR CONCEPT DEFINITION

ORGANIZATIONAL LEVEL AGE

DATE: 13 November 1978

DESCRIPTION OF AGE:

- o Flightline Equipment -
 - a. Test Adapter MX-9369/15M-455
 - b. Operational Control Indicator ID - 1853/ASM-455
 - c. Flightline Collimator SU-72/ASM-455
 - d. Boresighting Fixtures, Tools
- o Shop Equipment:
 - a. TS-3247/ASM-455 Electronics Tester
 - b. TS-3248/ASM-455 Optical Tester
 - c. TS-3245/ASM-455 Power Supply and Video Processor Tester

PURPOSE OF AGE:

- o Flightline Equipment:

Provides the means to align, test, and fault-isolate the TISEO system installed in the aircraft.
- o Shop Equipment:

Provides the capability to align/test the TISEO LRUs and fault-isolate a defective LRU to the defective SRU.

COMMENTS:

- o TS-3245/ASM-455 test set cables are far too short and require the UUT to be placed immediately next to the test set.
- o Blowers on the test sets are noisy and have been the cause of complaints to inspectors about poor working conditions.
- o TS-3248-ASM-455 did not include an appropriate maintenance stand.

DESIGN-FOR-REPAIR CONCEPT DEFINITION

PREVENTIVE MAINTENANCE

DATE: 13 November 1978

GENERAL DESCRIPTION:

- o Receiving Inspection/Alignment - LRUs from depot are tested and aligned prior to storage by supply.
- o 180 Day Inspection - Aircraft system is given operational check during radar inspection.

PREVENTIVE MAINTENANCE REQUIREMENT SOURCE:

Local maintenance directives require both the receiving and 180 day inspections.

COMMENTS:

- o Receiving inspections normally indicate units require alignments.
- o Receiving and 180 day inspections are considered to reduce write-ups by a discernable amount.
- o T.O. 1F-4E-6 does not require periodic system checks, however, TISEO shop personnel feel that LRU-1 should be aligned in the shop every 180 days.

DESIGN-FOR-REPAIR CONCEPT DEFINITION

TECHNICAL ORDERS

DATE: 13 November 1978

DESCRIPTION OF TECH DATA REQUIREMENTS:

- o Flightline Maintenance - T.O. 1F-4E-2-14
- o Intermediate Shop Maintenance - T.O. 12S6-2ASX1-2
T.O. 12S6-2ASX1-2-1 Classified Supplement
- o Depot Shop Overhaul Instructions - T.O. 12S6-2ASX1-3-1
T.O. 12S6-2ASX1-3-1-1 Classified Supplement
T.O. 12S6-2ASX1-3-2
T.O. 12S6-2ASX1-3-2-1 Classified Supplement
T.O. 12S6-2ASX1-3-3
T.O. 12S6-2ASX1-3-4

DESCRIPTION OF TECH DATA FIELD DISCREPANCIES:

The technical data is adequate to support this system. No significant discrepancies were discovered.

DESIGN-FOR-REPAIR CONCEPT DEFINITION

TRAINING & PERSONNEL SKILLS LEVEL

DATE: 13 November 1978

DESCRIPTION OF SKILLS REQUIREMENTS:

Authorized personnel for the photo-sensor shop are as follows:

7 levels - 1

5 levels - 6

3 levels - 2

DESCRIPTION OF ASSIGNED SKILLS:

Intermediate level photo/sensor shop-personnel assigned are as follows:

7 levels - 1

5 levels - 5

3 levels - 1

GENERAL COMMENTS:

Photo personnel are cross-training for sensor maintenance. Four of the personnel are cross-trainees. The 322 x 2B AFC personnel maintain the TISEO and 404 x 1 photo personnel maintain photo equipment and assist with TISEO maintenance.

DESIGN-FOR-REPAIR CONCEPT DEFINITION

TROUBLESHOOTING METHODS

DATE: 13 November 1978

DESCRIPTION OF ORGANIZATIONAL TROUBLESHOOTING METHODS:

- o Use ID-1853/ASM-455 to determine cause of BIT fail indication
- o Remove LRU-1 for checkout in intermediate shop
- o Remove LRU-2 for checkout in intermediate shop
- o Use MX-9269/ASM-455 to check interface signals

DESCRIPTION OF INTERMEDIATE TROUBLESHOOTING METHODS:

- o Functional test/fault-isolate LRU using test sets, T.O. procedures, and common test instruments.
- o SRU substitution (only when a replacement is ordered from supply).

DESCRIPTION OF DEPOT TROUBLESHOOTING METHODS:

- o Functional test/fault-isolate LRU using test sets, T.O. procedures, and common test instruments
- o SRU substitution
- o SRU testing on SRU test sets
- o Electro-mechanical component tests/alignments on special fixtures/test sets