



LEVEL

12

Research and Development Technical Report

NOG: 422 SC

DELET - TR - 78 - 0563 - 4

LITHIUM-THIONYL CHLORIDE BATTERY

A. N. DEY
N. HAMILTON
W. BOWDEN
P. WITALIS
D. CUBBISON

P. R. MALLORY & CO, INC.
LABORATORY FOR PHYSICAL SCIENCE
BURLINGTON, MA 01803

FEBRUARY 1980

FOURTH QUARTERLY REPORT
FOR PERIOD 1 AUGUST 1979 - 31 OCTOBER 1979

DDC
RECEIVED
FEB 14 1980
D

DISTRIBUTION STATEMENT :
APPROVED FOR PUBLIC RELEASE ; DISTRIBUTION UNLIMITED

PREPARED FOR :
US ARMY ELECTRONICS TECHNOLOGY AND DEVICES LABORATORY

ERADCOM

US ARMY ELECTRONICS RESEARCH AND DEVELOPMENT COMMAND
FORT MONMOUTH, NEW JERSEY 07703

DDC FILE COPY AD A 080734

024

NOTICES

Disclaimers

The citation of trade names and names of manufacturers in this report is not to be construed as official Government indorsement or approval of commercial products or services referenced herein.

Disposition

Destroy this report when it is no longer needed. Do not return it to the originator.

Unclassified

SECURITY CLASSIFICATION OF THIS PAGE (When Data Entered)

19 REPORT DOCUMENTATION PAGE		READ INSTRUCTIONS BEFORE COMPLETING FORM	
1. REPORT NUMBER 18 DELET-TR-78-0563-4	2. GOVT ACCESSION NO.	3. RECIPIENT'S CATALOG NUMBER	
4. TITLE (and Subtitle) 6 Lithium-Thionyl Chloride Battery	5. TYPE OF REPORT & PERIOD COVERED Fourth Quarterly Report 8/1/79 to 10/31/79		9 Quarterly Repts. no. 4, 1 Aug-31 Oct 79
7. AUTHOR(s) 10 A. N. Dey, N. Hamilton, W. Bowden, P. Witalis and D. Cubbison	6. PERFORMING ORG. REPORT NUMBER		8. CONTRACT OR GRANT NUMBER(s) 15 DAAB07-78-C-0563
9. PERFORMING ORGANIZATION NAME AND ADDRESS P. R. Mallory & Co. Inc. Laboratory for Physical Science Burlington, Mass. 01803	10. PROGRAM ELEMENT, PROJECT, TASK AREA & WORK UNIT NUMBERS 16 1L162705AH9411-219		
11. CONTROLLING OFFICE NAME AND ADDRESS U.S. Army Electronics Technology & Device Lab. ERADCOM Attn: DELET-PR Ft. Monmouth, New Jersey 07703	12. REPORT DATE 11 February 1980		13. NUMBER OF PAGES 49
14. MONITORING AGENCY NAME & ADDRESS (if different from Controlling Office) 1259	15. SECURITY CLASS. (of this report) Unclassified		15a. DECLASSIFICATION/DOWNGRADING SCHEDULE
16. DISTRIBUTION STATEMENT (of this Report) Approved for Public Release Distribution Unlimited		17 11	
17. DISTRIBUTION STATEMENT (of the abstract entered in Block 20, if different from Report)			
18. SUPPLEMENTARY NOTES			
19. KEY WORDS (Continue on reverse side if necessary and identify by block number) Inorganic electrolyte battery, thionyl chloride, lithium, high rate D cell, high rate flat cylindrical cell, laser designator battery.			
20. ABSTRACT (Continue on reverse side if necessary and identify by block number) We have demonstrated a cell capacity of greater than 20 Amp-hr for the three inch flat cell on the GLLD test. We optimized these cells with regard to electrode area and cathode additive. This cell has now exceeded design per- formance goals. We optimized the very high rate wound D cell for electrolyte concentration,			

215 325

Handwritten signature

Unclassified

SECURITY CLASSIFICATION OF THIS PAGE(When Data Entered)

→ cathode additive and electrode length. The high rate D cells delivered 24 bursts (or 8 Amp.hr/cell) on the GLLD test cycle compared to 3 bursts from the currently used Ni/Cd batteries.

We developed the 1.8 inch diameter cylindrical cell and tested it on the GLLD test. This cell delivered 12-13 Amp-hrs which was inferior to the flat cell and the high rate D cell. Accordingly, we discontinued any further development on this cell. We converted our test apparatus to the new GLLD test cycle which consists of alternating 20 Amp and 3.2 Amp pulses. The flat cells performed equally well under this new test regime.

Accession For	
NTIS GRA&I	<input checked="" type="checkbox"/>
DDC TAB	<input type="checkbox"/>
Unannounced	<input type="checkbox"/>
Justification	
By _____	
Distribution/	
Availability Codes	
Dist.	Avail and/or special
A	

Unclassified

SECURITY CLASSIFICATION OF THIS PAGE(When Data Entered)

TABLE OF CONTENTS

	Page No.
List of Figures	1
I. Introduction	1
II. Laser Designator Battery	3
III. Spirally Wound D Cell	5
Introduction	5
Experimental	5
Results and Discussion	6
1. Electrolyte Concentration	6
2. Cathode Additives	7
3. Electrode Length	7
Conclusion	9
IV. Development of the 1.8 Inch Diameter Cylindrical Cell	10
Introduction	10
Experimental	10
Results and Discussion	11
Conclusion	11
V. The Flat Cylindrical Cell	13
Experimental	13
Results and Discussion	13
Number of Cathodes	14
Cathode Additive	15
Conclusions	15
VI. Conclusion	16
VII. References	17

Figure Captions

- Fig. 1. Schematic outline for the GLLD battery using 8 x 3" O.D., 0.90" thick flat cells.
- Fig. 2. Diagram for the new GLLD Laser Designator test cycle.
- Fig. 3. Diagram of cathode configurations used for D cells;
(a) standard cells and cathode additives; (b) long electrode cells.
- Fig. 4. Performance of a pair of D cells with 1.4M LiAlCl_4 on GLLD test.
- Fig. 5. Performance of a pair of D cells with 1.4M LiAlCl_4 on GLLD test.
- Fig. 6. Performance of a pair of D cells with cathode additive 2 at level B on GLLD test.
- Fig. 7. Performance of a pair of D cells with cathode additive 2 at level C on the new GLLD test.
- Fig. 8. Performance of a pair of D cells with cathode additive 2 at level C on the new GLLD test.
- Fig. 9. Performance of a pair of D cells with cathode pretreatment on the GLLD test.
- Fig. 10. Polarization curve for a D cell with 35" pretreated cathode.
- Fig. 11. Performance of a pair of D cells with 35" pretreated cathodes on the GLLD test.
- Fig. 12. Behavior of a pair of D cells with pretreated 35" cathodes during voltage reversal at 2A.
- Fig. 13. Performance of a pair of D cells with 35" pretreated cathodes on the GLLD test.
- Fig. 14. Performance of a pair of resistively discharged D cells with 35" pretreated cathodes in reversal at 2A.
- Fig. 15. Performance of a pair of D cells with 40" pretreated cathodes on the GLLD test.

- Fig. 16. Performance of a pair of cells with 40" pretreated cathodes on the GLLD test.
- Fig. 17. Schematic diagram of the stainless steel can for the 1.8 inch diameter spirally wound cylindrical cell.
- Fig. 18. Schematic drawing of the Kovar cell top for the 1.8 inch diameter cylindrical cell.
- Fig. 19. Schematic drawing of the completer 1.8 inch diameter cell top with fill port, vent and G/M feedthrough.
- Fig. 20. Photograph of the finished 1.8 inch diameter cylindrical cell.
- Fig. 21. Performance of a 1.8 inch diameter cylindrical cell on the old GLLD test cycle.
- Fig. 22. Performance of a 1.8 inch diameter cylindrical cell on the new GLLD test cycle.
- Fig. 23. Schematic drawing of the interior of a flat cylindrical cell.
- Fig. 24. Performance of a flat cell with double anodes on the GLLD test.
- Fig. 25. Performance of a flat cell with 32 cathodes on the old GLLD test cycle.
- Fig. 26. Performance of a flat cell with 32 cathodes on the new GLLD test cycle.
- Fig. 27. Performance of a flat cell with 40 cathodes on the old GLLD test.
- Fig. 28. Performance of a flat cell with 36 cathodes on the new GLLD test.
- Fig. 29. Performance of a flat cell with 36 cathodes on the new GLLD test.
- Fig. 30. Current-voltage curve for a flat cylindrical cell.
- Fig. 31. Performance of the flat cell from Fig. 30 on the GLLD test.
- Fig. 32. Performance of a flat cell with cathode additive 1 at level A on the GLLD test.

I. Introduction

The Li/SOCl₂ inorganic electrolyte system (1-4) is the highest energy density system known to date. It consists of a Li anode, a carbon cathode and SOCl₂ which acts both as a solvent and as a cathode active material. The electrolyte salt that has been used most extensively is LiAlCl₄, but salts such as Li₂B₁₀Cl₁₀ (5) and Li₂O (AlCl₃)₂ (6) have also been used successfully in this system for improving the shelf life characteristics.

The main objective of this program is to develop high rate Li/SOCl₂ cells and batteries for portable applications of the U. S. Army. The cells and batteries must deliver higher energy densities than are presently available and must be safe to handle under field conditions.

We carried out a detailed development (7) on the spirally wound high rate D cell in order to establish their performance capabilities and to identify and correct limitations in their performance and safety under various use and abuse conditions. Substantial progress was made in correcting cell limitations. We found that spirally wound D cells approached the high rate requirements of various U. S. Army applications more closely than do any other cell designs at the present time. We used this spirally wound D cell as a starting point and improved its rate capability to meet the requirements of two specific applications, namely the BA5590 battery for man pack radio and the battery for the GLLD Laser Designator.

We concentrated our effort on the development of the high rate spirally wound D cell during the first two quarters to determine whether it was possible to meet the performance requirements of the GLLD Laser Designator. The results we obtained in the second quarter showed that the high rate D cells could deliver eighteen (18) bursts or 5.9 A.hr/cell compared to the three (3) bursts realized from the presently used Ni/Cd batteries. The advantage of using D cells, as opposed to a flat cell, is that the D cells can be manufactured at our lithium battery manufacturing plant with only slight modifications of the existing process used for manufacturing spirally wound Li/SO₂ D cells. The results obtained were

encouraging and we are continuing to improve the Li/SOCl₂ D cell so that it can meet a variety of high rate requirements, including the GLLD application.

During the third quarter we concentrated our effort on the development of the three inch diameter flat cell for the GLLD Laser Designator battery. We had already initiated the procurement of parts during the first quarter. The detailed design of the flat cell and its parts, and the design and fabrication of tooling needed to make the parts and cell was mostly completed during the third quarter. We have developed two types of flat cell, one is 0.45 inch thick while the other is 0.90 inch thick. The packaging efficiency of the battery with 0.9 inch cells is significantly higher than with 0.45 inch thick cells. The construction and performance characteristics of both types of flat cells were described in the third quarterly report.

During the first two quarters we also examined the cell reaction mechanisms using cyclic voltammetry. The information gained from this study indicated several approaches for improving the performance and safety of Li/SOCl₂ cells. We evaluated the efficacy of these approaches in spirally wound D cells during the third quarter and found that both performance and abuse resistance of the cells was significantly improved by the use of additives. We evaluated some of the promising additives in the three inch diameter flat cell during the fourth quarter and the results are reported here.

During the fourth quarter we made additional engineering improvements to the 0.9 inch thick flat cell to further enhance its performance. We found that the abuse resistance and the cell capacity of the D cell on the GLLD test were increased by the use of cathode additives. We also investigated the use of very long and thin electrodes to increase capacity on the GLLD test. Our results are described in this report.

The GLLD test apparatus was modified to use the new GLLD test cycle which consists of a 20A pulse for 0.029 sec followed by a 3.2A pulse for 0.021 sec which is continued for 20 seconds and repeated every 3 minutes. Cell capacities on the new and old GLLD test regimes were very similar, while the shorter duration of the bursts gave less cell heating than before.

II. Laser Designator Battery

The specifications of the GLLD Laser Designator Battery are as follows:

Dimensions: 2.82" x 3.75" x 9.30"

Voltage: 24V nominal

Maximum (OCV) 32V

Average 24V

End Voltage 20V

We considered the following types of individual cells for the above battery:

A. 16 spirally wound D cells; 8 in series, with the two series stacks in parallel.

B. 16 flat cells (3 inch O.D., 0.45 inch thick); 8 in series, with the two series stacks in parallel.

C. 8 flat cells (3 inch O.D.; 0.90 inch thick) in series as shown schematically in Fig. 1.

D. 8 cylindrical 1.8" diameter spirally wound cells in series.

The development of the D cell and the two types of flat cell were described in the three preceding reports (8-10). The development of the 1.8 inch diameter cell is described in this report.

The duty cycle on which the cells were tested earlier is as follows:

17.5A for 0.0355 sec followed by 1.8A for .0145 sec; this cycle continues for 3 minutes. This constitutes one burst. This three minute cycle occurs every thirty minutes.

The above duty cycle has been changed by the sponsor. The new duty cycle is as follows:

20A for 0.029 sec followed by 3.2A for 0.021 sec; this cycle continues for 20 seconds every three minutes. The duty cycle is shown schematically in Figure 2. We modified our test apparatus to accommodate the above duty cycle.

During the fourth quarter we concentrated our efforts on the Laser Designator Battery, specifically in the following three areas:

1. Improvement of the spirally wound D cell.
2. Development of the 1.8 inch diameter spirally wound cell.
3. Improvement of the 0.9 inch thick flat cell.

The details are discussed in the following sections of the report.

III. Spirally Wound D Cell

Introduction

The use of spirally wound D cells is attractive for the GLLD Laser Designator Battery because the technology is well developed, and the cell incorporates proven packaging with a hermetic glass-to-metal seal and a low pressure vent which is hermetic until opening on accidental short circuiting or other abusive use. The spirally wound cell is easy to construct and as such is a good vehicle for studying the effect of cell construction variables on the performance. Finally the spirally wound Li/SOCl₂ D cell can be manufactured at our lithium battery manufacturing facility with a minimum of alterations and minimum new tooling.

We have developed the spirally wound D cell for the GLLD application by examining a number of different techniques for cathode current collection and adopting the most satisfactory ones. This gave a D cell which, when tested in pairs, gave eighteen (18) bursts on the GLLD test cycle. We examined a number of cathode additives in the spirally wound D cell with the optimum current collection arrangement. These additives gave improved abuse resistance on voltage reversal to the spirally wound D cell and also increased cell capacity to 20-22 bursts or 7.3 A.hr vs. 6 A.hr for the cells without additive.

During the fourth quarter we further developed the D cell by examining some further variables. These included:

1. Electrolyte concentration
2. Cathode additives
3. Cathode pretreatment
4. Cathode length

Experimental

The electrolyte and cathode additives were evaluated in D cells of the now standard hermetic construction with the glass-to-metal seal hermetic vent and 25" cathodes with current collection via one center and two end tabs. In

these cells the electrode stack, consisting of cathode, separator, and anode is wound about a mandrel and inserted into the can. The anode tab is welded to the center post in the top and the cathode tabs are welded to the can during the welding of the cell top onto the can.

The cathode pretreatment and electrode length experiments required slight modifications of the above procedure. Both the 35" and 40" cathodes had three tabs for current collection, one in the center of the electrode, while the two others were placed 6" from the respective ends of the cathode. For the cells with 40" electrodes, the lithium anode had a current collector tab at both ends of the anode (Fig. 3). All of these experimental modifications were intended to improve the high rate performance of the D cell and the effects of these changes were evaluated using the GLLD test cycle on a pair of cells connected in parallel.

Results and Discussion

1. Electrolyte Concentration

We suspected that the 1.8M LiAlCl_4 electrolyte used in the cell might be too concentrated for best results. While 1.8M is very near the conductivity maximum for LiAlCl_4 in SOCl_2 , partial discharge of the cell increases the LiAlCl_4 concentration, leading to reduced conductivity and, perhaps, premature cathode passivation due to LiAlCl_4 precipitation. Since conductivity changes relatively slowly with concentration at high electrolyte concentrations we selected 1.4M LiAlCl_4 as an alternative electrolyte concentration and tested two pairs of D cells having the cathode configuration shown in Fig. 3(a) on the GLLD test cycle. The performance of these cells with 1.4M LiAlCl_4 electrolyte on the GLLD test is shown in Figures 4 and 5. Both cell pairs delivered only 12 bursts, or 4 A.hr/cell compared to 18 bursts or 6 A.hr/cell for an identical cell filled with 1.8M LiAlCl_4 electrolyte. The 1.4M LiAlCl_4 cells also had a voltage penalty, with a voltage of less than 2.5V at 17.5A compared to 2.75-2.85V for cells with 1.8M LiAlCl_4 . The voltage penalty of $\sim 10\%$ coupled with a 30% loss in capacity indicates there is little benefit to be gained from a reduction in LiAlCl_4 concentration for the GLLD Laser Designator Battery.

2. Cathode Additives

In the third quarter we examined the effect of cathode additives on D cell performance in the GLLD test and identified two additives with beneficial effects on cell performance. Additive "1" was evaluated at two levels, while additive "2" was tested at only one level. We have evaluated the effect of cathode additive "2" at two further levels in the D cell with 25" cathode with a center and two end tabs for current collection (Fig. 3(a)). The performance of a pair of D cells with cathode additive "2" at level B is shown in Fig. 6. The cell capacity of 17 bursts or 5.6 A.hr/cell is very similar to that for a cell without additive and the additive appears ineffective at this level.

We tested two further pairs of cells with cathode additive "2" at level C. These cells were tested on the new GLLD test cycle. The results are shown in Figures 7 and 8. The cell capacities of 7.4 and 7.55 A.hr/respectively are approximately 25% better than the standard cell, or 22 bursts under the old GLLD test cycle. The load voltages at high current were also near 2.5-2.6V, which is higher than we observed earlier with additive "2" at level A. For cathode additive "2", level C gives increased cell capacity without a penalty in discharge voltage and thus seems most satisfactory.

3. Electrode Length

We suspected that cathode passivation was the limiting factor in D cell performance on the GLLD test and examined the effect of greatly increasing electrode area within the D cell. This increased the resistive loss in the cathode because of the greater length but increases the amount of cathode material while decreasing the current density at the electrodes.

We first made a pair of D cells with 25" electrodes which were made slightly differently than the standard. These cells were filled with 1.8M LiAlCl_4 - SOCl_2 electrolyte. This cell pair was tested on the old GLLD test cycle with results shown in Fig. 9. The capacity of 19 bursts on 6.3 A.hr/cell is similar to that of a standard cell, while the load voltage of ~ 2.7 was also near that of a standard cell. The alteration of the cathode fabrication process does not appear to affect the D cell performance on the GLLD test. We used this process for the

remainder of the cells.

We then prepared two pairs of D cells with 35" electrodes and current collection as in Fig. 3(b). A polarization curve was run on one cell before test to verify the high rate capability. The polarization curve shown in Fig. 10 indicates a cell voltage of 3.0V at 5 Amps demonstrating the high current capability of these cells. We then tested a pair of cells on the new GLLD test, as shown in Fig. 11. The cells delivered 230 pulses before polarizing, for a cell capacity of 8.05 A.hr, a 33% improvement on the 6 A.hr of the standard cell while the load voltage at 20A was above 2.5V for all but the last period of the discharge. This pair of cells was driven into reversal at 2A, with one cell venting quietly 16 hours into reversal as shown in Fig. 12 at a cell voltage near -1 volt and a wall temperature of 41°C. A second pair of D cells was prepared with 35" pretreated cathodes and tested on the GLLD test as shown in Fig. 13. The cell capacity of 8.05 A.hr/cell or 230 bursts was similar to that of the earlier pair of identical cells, once more the load voltage stayed above 2.5V for nearly all of the discharge. Due to a malfunction in the test equipment this pair of cells was resistively discharged down to near 0V, before being driven into reversal at 2A, as shown in Fig. 14. The cells ran quietly for 60 hours in reversal without venting. This is well past Li exhaustion.

To test the practical limits of electrode length in a conventional spirally wound D cell, we prepared some cells using the cathode pretreatment and 40" electrodes. These cells were also filled with 1.8M LiAlCl_4 electrolyte and examined on the GLLD test. The performance of these cells, shown in Fig. 15 and 16 was somewhat disappointing. The cell pairs delivered 220 and 243 bursts, respectively, for capacities of 7.8 A.hr/cell and 8.7 A.hr/cell respectively. We found the load voltage at 20A to be 2.70-2.75, but there was no significant increase in cell capacity. One problem with the use of such extremely long electrode stacks is that the portion of the cell volume occupied by the separator increases very substantially. For example, with 40" electrodes and .005" separators, about 34% of the available electrode volume is taken up

separator. This, combined with our test results on the 35 and 40 inch cathodes suggests that 35 inch cathodes are near the optimum for a spirally wound high rate D cell.

Conclusion

We evaluated the effects of three variables on D cell performance in the GLLD test during the fourth quarter. These variables were electrolyte concentration, cathode additive level, and electrode length. We found that the currently used electrolyte of 1.8M LiAlCl_4 in SOCl_2 was superior to the alternative 1.4M LiAlCl_4 electrolyte in both capacity and load voltage on the GLLD test at room temperature. We evaluated cathode additive "2" at two further levels than examined in the third quarter and found a level which combined a satisfactory load voltage with an increased cathode capacity compared to the standard cells. We evaluated the effect of electrode lengths of 35 and 40 inch, and found that a substantial capacity increase, from 6.0 to ~ 8.5 A.hr could be obtained at no penalty in load voltage.

IV. Development of the 1.8 Inch Diameter Cylindrical Cell

Introduction

We chose to develop the 1.8 inch diameter cylindrical cell for the GLLD Laser Designator Battery to reduce the number of cells required from 16 to 8. The construction of this cell uses the technology already developed for the spirally wound D cell, including wound electrode geometry, low pressure glass-to-metal seal hermetic vent, glass-to-metal seal feedthrough and fill port in the cell top. The details of the development are presented here.

Experimental

Cell Can: The stainless steel cans with dimensions of:

O.D: 1.812" \pm 0.010"
Ht.: 2.609" \pm 0.015"
Wall: 0.031" \pm 0.003"

were procured from an outside vendor and were found to be in accordance with the specification. A schematic drawing of the can is shown in Fig. 17.

Cell Top: The cell top is made of Kovar and has the following dimensions:

O.D.: 1.750 \pm 0.010"
Ht.: 0.188 \pm 0.010"

This part was procured from an outside vendor. The drawing for the cell top is shown in Fig. 18.

G/M Seal: The glass-to-metal seal with the hermetic feedthrough for the center post was fabricated in the laboratory using the seal technology developed for the Li/SOCl₂ D cell.

Vent: The cell top has a G/M seal vent similar to that developed for the D cell which was also fabricated in the laboratory. A schematic diagram of the completed cell top with electrolyte fill port, vent and G/M seal feedthrough is shown in Fig. 19.

Welding Fixture: The necessary heat sinking fixtured for TIG welding the cell top and can were designed and built during the fourth quarter. The welding step was perfected using empty cans. No unusual difficulties were encountered in this operation. The efficiency of the heat sinking was determined by checking the temperature of the can wall after welding. The temperature was found to remain within safe limits.

Cell Construction: Cells were made by winding two layers of 2" x 20" cathodes and two layers of 2" x 21" anodes arranged alternately and separated by layers of glass filter paper. The cathodes each have two tabs located 5" from the ends while the anodes have two tabs located at the ends. Thus, both anode and cathode have four tabs each for current collection.

The cells were filled with about 90 grams of 1.8M LiAlCl_4 in SOCl_2 through the fill port, which was then closed. A photograph of the finished cell is shown in Fig. 20.

Results and Discussion

One cell was tested at room temperature on the old GLLD test cycle of alternating 17.5A and 1.8A pulses. The results are shown in Fig. 21. The cell delivered 19 bursts above 2.0V which corresponds to a capacity of 12.5 A.hr. Another cell was tested on the new GLLD test cycle with the results shown in Fig. 22. The cell delivered 179 bursts to give a capacity of 12.9 A.hr.

Conclusion

Considering the fact that 1.8" diameter cylindrical cell has twice the internal volume of the D cell, the performance on GLLD test was inferior to that of a pair of D cells in parallel. Particularly, the voltage on the high current pulse was only around 2.0V, which is below the required cutoff voltage of 2.5V. For this reason we decided to discontinue the development of the 1.8" diameter

cell and to concentrate our efforts on the 0.9" thick flat cell to fulfill the
GLLD Laser Designator application requirements.

V. The Flat Cylindrical Cell

The flat cylindrical cell which we developed during the first and third quarters has shown a load voltage and capacity superior to those of the highly developed high rate spirally wound D cell. During the fourth quarter we examined several approaches to optimizing the performance of the flat cell, these were:

1. Anode thickness
2. Number of cathodes
3. Cathode additive

Experimental

The design and construction of the 3 inch diameter, 0.9 inch high flat cylindrical cell was discussed in some detail in the third quarter report. The flat cylindrical cell has flat electrodes having cathodes connected to the can and lithium anode at the center post as shown in Fig. 23. The cell also incorporates a G/M hermetic feedthrough, a fill port and low pressure hermetic vent. All cells were filled and tested with the 1.8M LiAlCl_4 in SOCl_2 electrolyte.

Results and Discussion

Flat cells discharged in the third quarter showed a high utilization of the lithium anode and led us to suspect that anode polarization was limiting cell capacity. To test this hypothesis we built a flat cell with double the previous anode capacity. This cell, which included thirty cathodes was tested on the GLLD test with results shown in Fig. 24. The cell capacity of only 14.6 A.hr was very low for the flat cell. We decided that factors other than anode polarization were limiting performance of the flat cell.

Number of Cathodes

We decided to optimize the design of the flat cell with respect to the number of cathodes by testing the cells at room temperature. We plan to use the optimal design for the evaluation of the flat cells at other temperatures. Two flat cells were made with 32 cathodes and 33 anodes. One cell was discharged on the old GLLD duty cycle. The results are shown in Fig. 25. This cell polarized during the 26th burst after delivering 16.7 A.hr with the load voltage at 17.5A above 3V for most of the discharge life. The other 32 cathode cells were filled with 1.8M LiAlCl_4 and discharged on the new GLLD test cycle, as shown in Fig. 26. The cell delivered 230 bursts, or 16.1 A.hr, on this test with a final voltage of 2.6V at 20A, while the load voltage was mostly above 3V. This replication of performance between the two tests shows that the new and old GLLD tests give similar values for cell capacities.

We then made a cell with 40 cathodes, and discharged this cell on the old GLLD test. The performance of this cell, shown in Fig. 27, was not as good as hoped in that the cell gave 25 bursts or 16.8 A.hr. There was no improvement on the previous cells in spite of a 20% increase in electrode area.

We then made a cell with 36 cathodes. On the new GLLD test this cell gave 290 bursts, which corresponds to a capacity of 20.3 A.hr. The cell voltage on the 20A load was near 3.2V for most of the discharge and only reached 2.5V at the 290th burst. The performance of this cell is shown in Fig. 28. To confirm this performance, we prepared a second cell with 36 cathodes and tested it also at room temperature on the new GLLD test cycle. This cell delivered 287 bursts or 20.1 A.hr, as shown in Fig. 29. The cell polarization in 20A load was remarkably low. This led to a minimum temperature rise during use. The cell temperature remained below 30°C all throughout the test. This is a major accomplishment with this cell design.

We also tested the high current capability of the flat cell by polarizing it at high currents. The current-voltage curve for this cell is shown in Fig. 30. The cell performance was quite impressive giving 2.95V at 50 Amps, a power density of around 330 W/lb. This cell was then discharged on the GLLD test,

delivering 240 bursts, or 16.8 A.hr, as shown in Fig. 31. We have determined from these data that 36 cathodes is near the optimum for the 3" flat cell on the GLLD test.

Cathode Additive

Since the use of cathode additives has been shown to improve the capacity of spirally wound D cells, we prepared a flat cell with cathode additive "1", at level A. This cell was discharged on the GLLD test as shown in Fig. 32. The cell gave 302 bursts before polarizing. This corresponds to a capacity of 21.1 A.hr, a further improvement on the optimized flat cells. The voltage regulation also was superior to the cells without the additive.

Conclusions

During the fourth quarter we continued to improve the flat cell, showing optimization with regard to electrode area giving a 20% improvement in capacity on the GLLD test. We also found that cathode additive "1" could be used to give a modest improvement in the capacity. The flat cells could be operated at very high currents and power densities with low overvoltages.

The performance of the flat cell exceeded our goal of 20 A.hr. The volumetric energy density of the cell is approximately 10 WHr/in³ and the gravimetric energy density is 145 Whr/lb on the GLLD test consisting of 20A pulses. Note that the weight of the can is approximately 40% of the total cell weight and improvements may be expected in this area.

VI. Conclusion

During the fourth quarter we concentrated on the development of high rate cells for use in the GLLD Laser Designator Battery. We split our development effort amongst three cell configurations, the spirally wound D cell, the spirally wound 1.8 inch diameter cylindrical cell and the 3 inch diameter, 0.9 inch high flat cylindrical cell. We examined the effects of electrolyte concentration, cathode additive and electrode length on the D cell performance on the GLLD test and found near optimum levels of each variable under GLLD test conditions. These high rate D cells can now deliver over 8 Amp-hr on the GLLD test.

We developed the 1.8 inch diameter cylindrical cell during this quarter, and evaluated its performance on the GLLD test, and determined its performance to be slightly inferior to a pair of D cells. We discontinued any further development work on this cell.

We optimized the flat cell with respect to electrode area and demonstrated some improvement from cathode additives. The flat cell demonstrated a consistent capacity of 20 Amp-hr or more on the GLLD test and is capable of substantially greater power densities than required for this application. The low cell polarization on high current pulse, not only leads to improved cell performance, but also resulted in a minimal temperature rise during cell operation, thus improving the safety.

During the next quarter we plan to complete the development of the D cell for the BA5590 application and to examine the low temperature discharge, capacity retention, and abuse resistance for the flat cylindrical cell.

VII. References

1. W. K. Behl, J. A. Cristopulos, M. Ramirez and S. Gilman, J. Electrochem. Soc., 120, 1619 (1973).
2. J. J. Auburn, K. W. French, S. I. Lieberman, V. K. Shah and A. Heller, *ibid*, 120, 1613 (1973).
3. D. L. Maricle et al, U. S. Pat. 3, 567, 515 (1971); G. E. Blomgren and M. L. Kronenberg, German Pat. 2, 262, 256 (1973).
4. A. N. Dey and C. R. Schlaikjer, Proc. 26th Power Sources Symposium, Atlantic City, April 1974.
5. C. R. Schlaikjer, U. S. Pat. 4,020,240 (1977), Proc. 28th Power Sources Symposium, Atlantic City, June 1978.
6. J. P. Gabano and P. Lenfant, Abstract No. 27, Electrochemical Society Meeting, Pittsburg, PA., Oct. 1978.
7. A. N. Dey, "Sealed Primary Lithium Inorganic Electrolyte Cell" Final Report, DELET-TR-74-0109-F, P. R. Mallory & Co., Inc. July 1978.
8. A. N. Dey, W. Bowden, J. Miller, P. Witalis, "Lithium-Thionyl Chloride Battery", ERADCOM, DELET-TR-78-0563-1, First Quarterly Report, P. R. Mallory & Co. Inc., April, 1979.
9. A. N. Dey, W. Bowden, J. Miller, P. Witalis, "Lithium-Thionyl Chloride Battery", ERADCOM, DELET-TR-78-0563-2, Second Quarterly Report, P. R. Mallory & Co. Inc., July, 1979.
10. A. N. Dey, N. Hamilton, W. Bowden, P. Witalis, "Lithium-Thionyl Chloride Battery, ERADCOM, DELET-TR-78-0563-3, Third Quarterly REPORT, P. R. Mallory & Co. Inc., July, 1979.

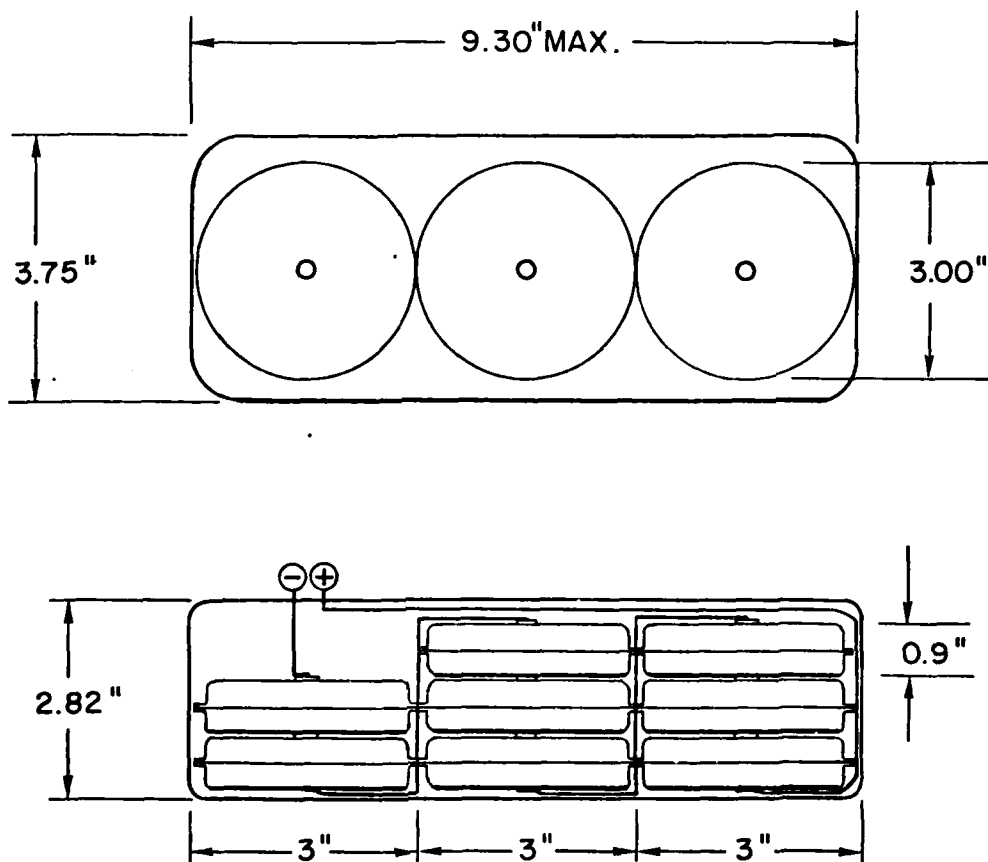

Fig. 1. Schematic outline for the GLLD battery using 8 x 3" O.D.,
0.90" thick flat cells.

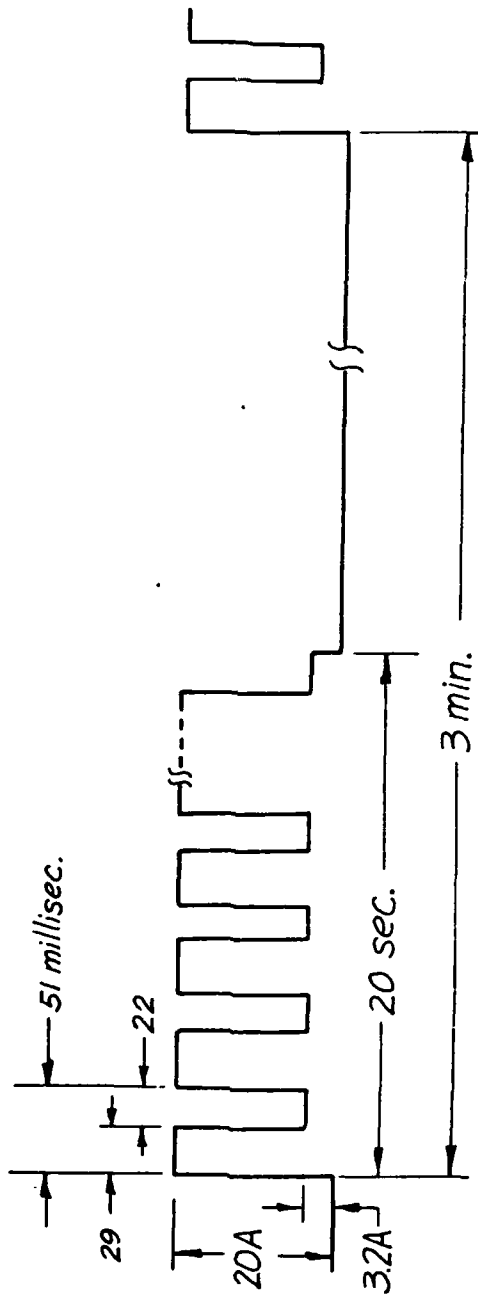

Fig. 2. Diagram for the new GLLD Laser Designator test cycle.

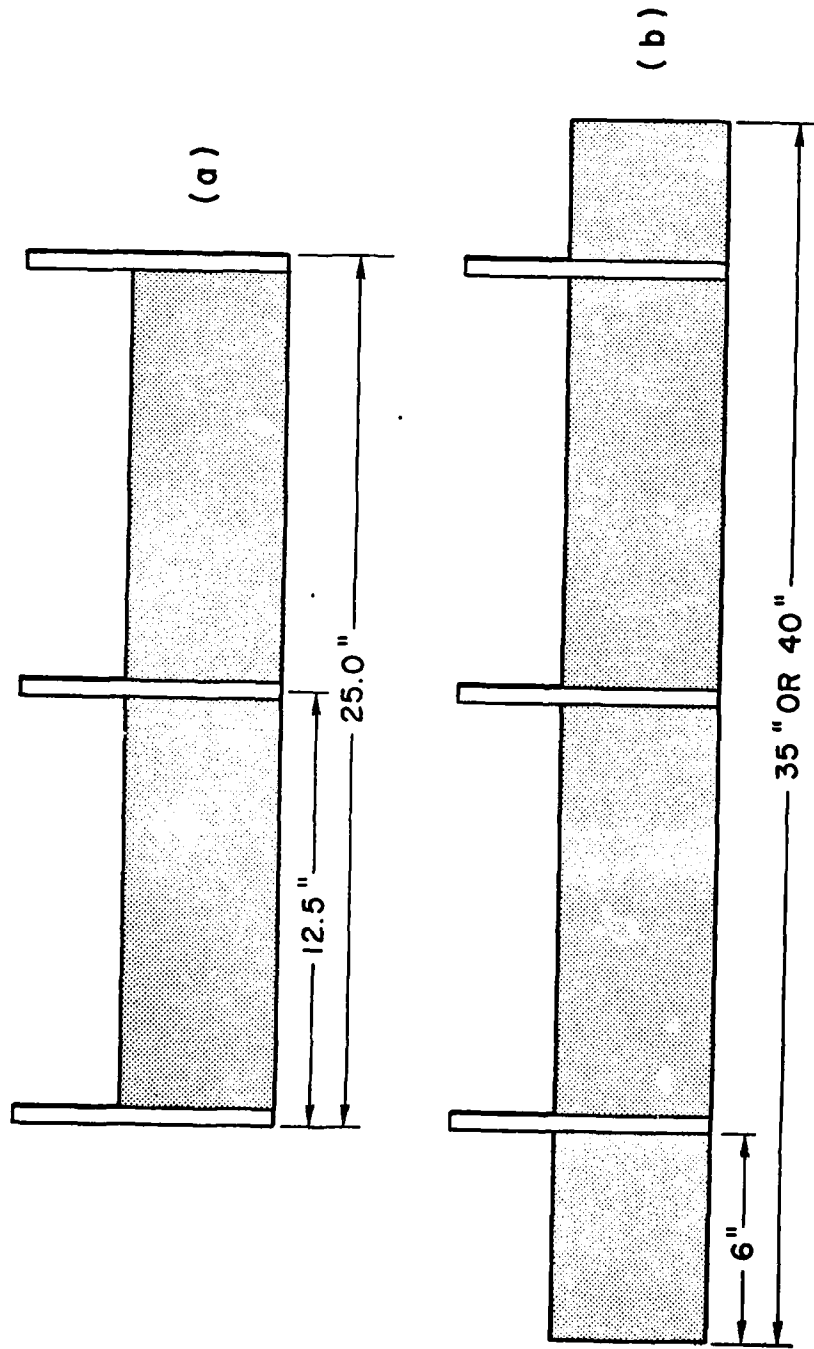

Fig. 3. Diagram of cathode configurations used for D cells;
(a) standard cells and cathode additives;
(b) long electrode cells

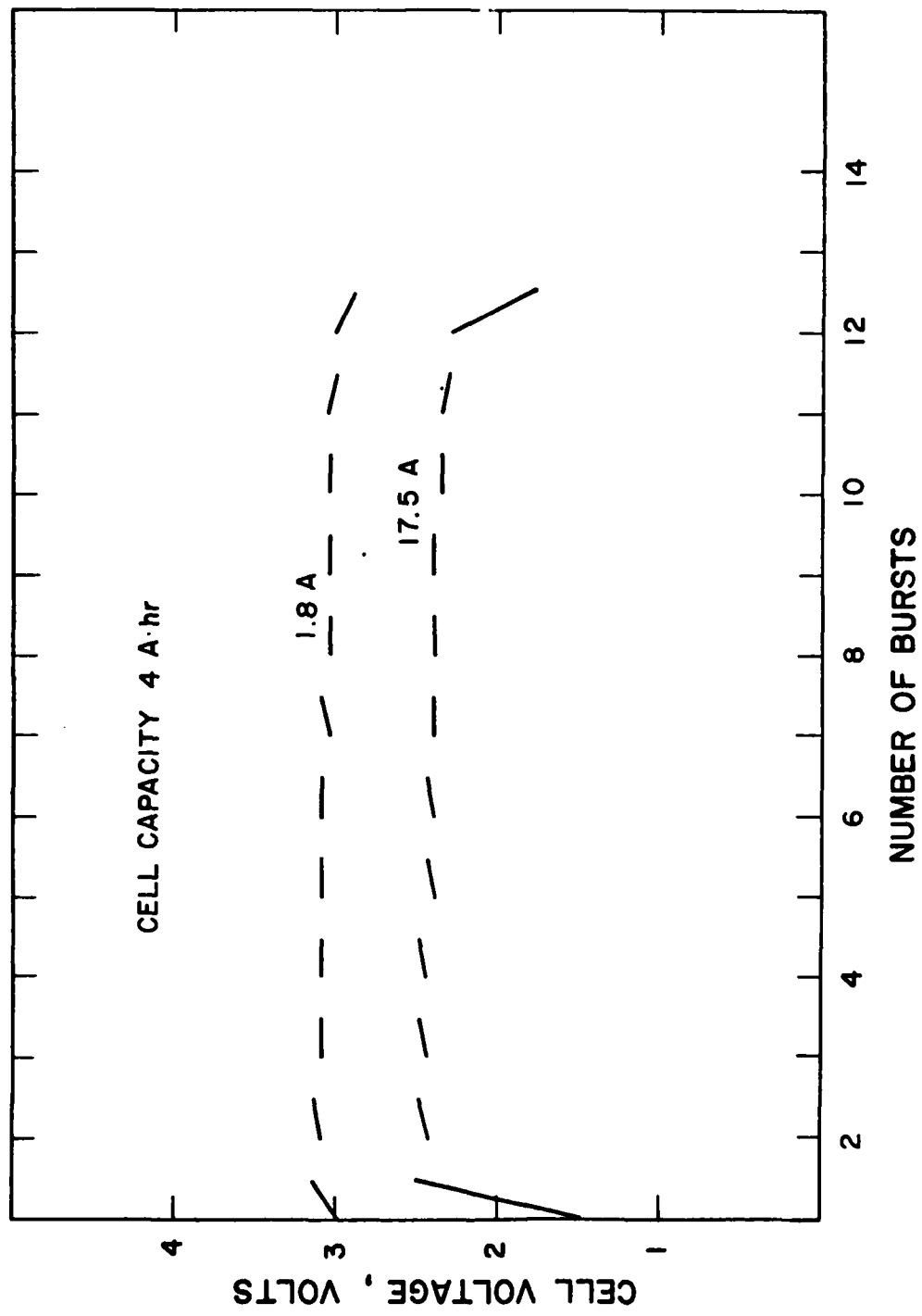

Fig. 4. Performance of a pair of D cells with 1.4M LiAlCl₄ on GLLD test

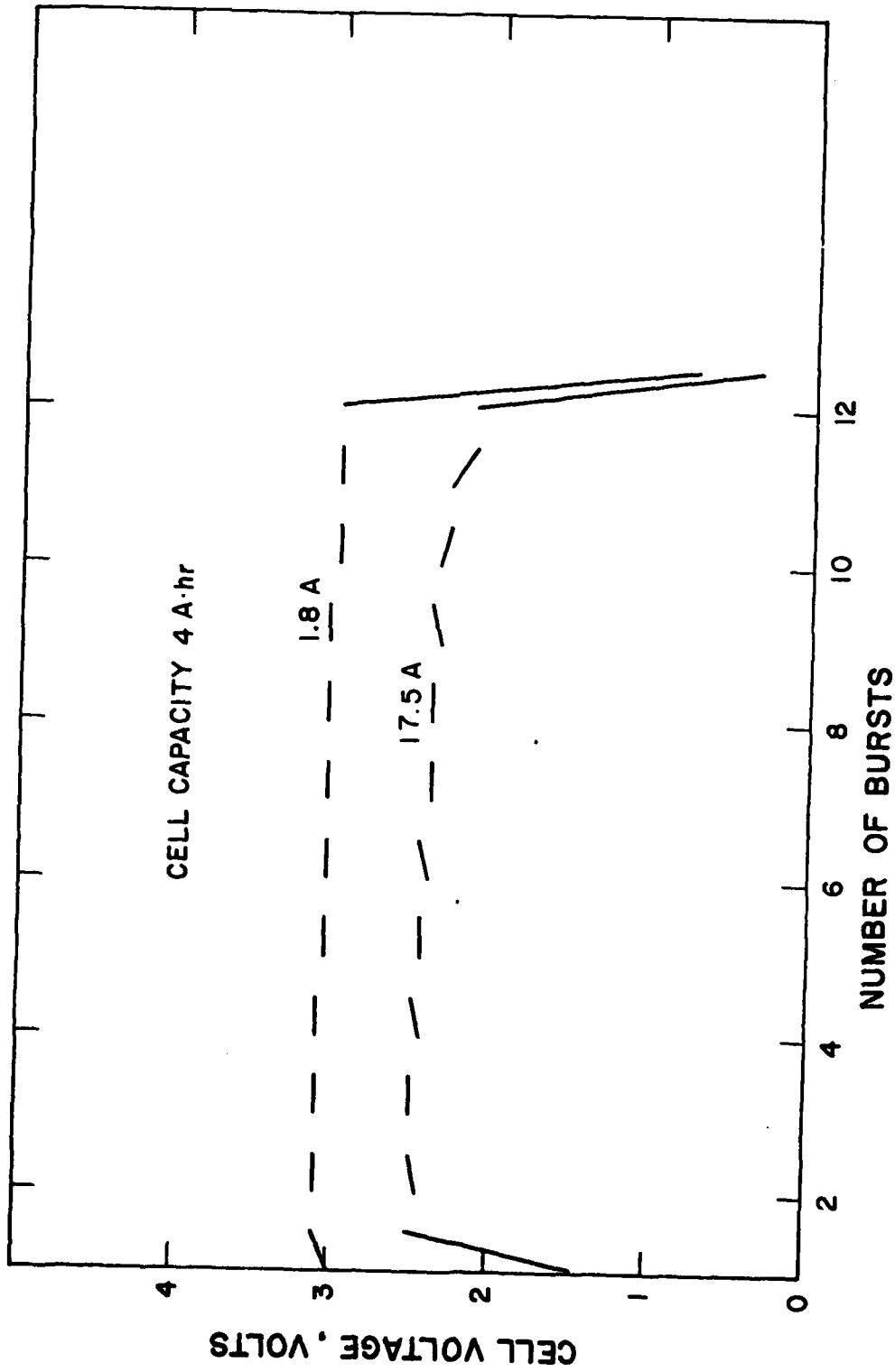

Fig. 5. Performance of a pair of D cells with 1.4M LiAlCl₄ on GLLD test.

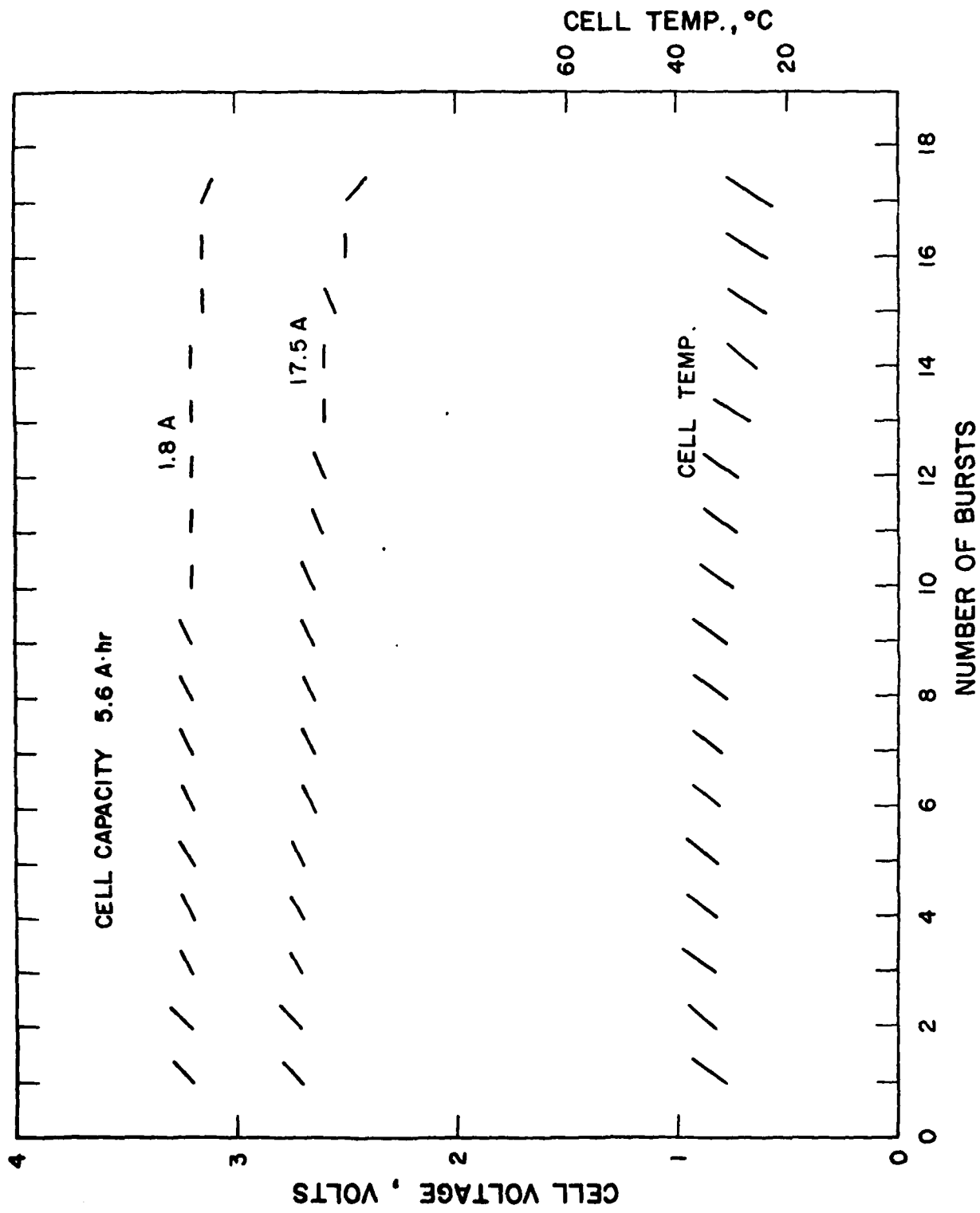

Fig. 6. Performance of a pair of D cells with cathode additive 2 at level B on GLLD test.

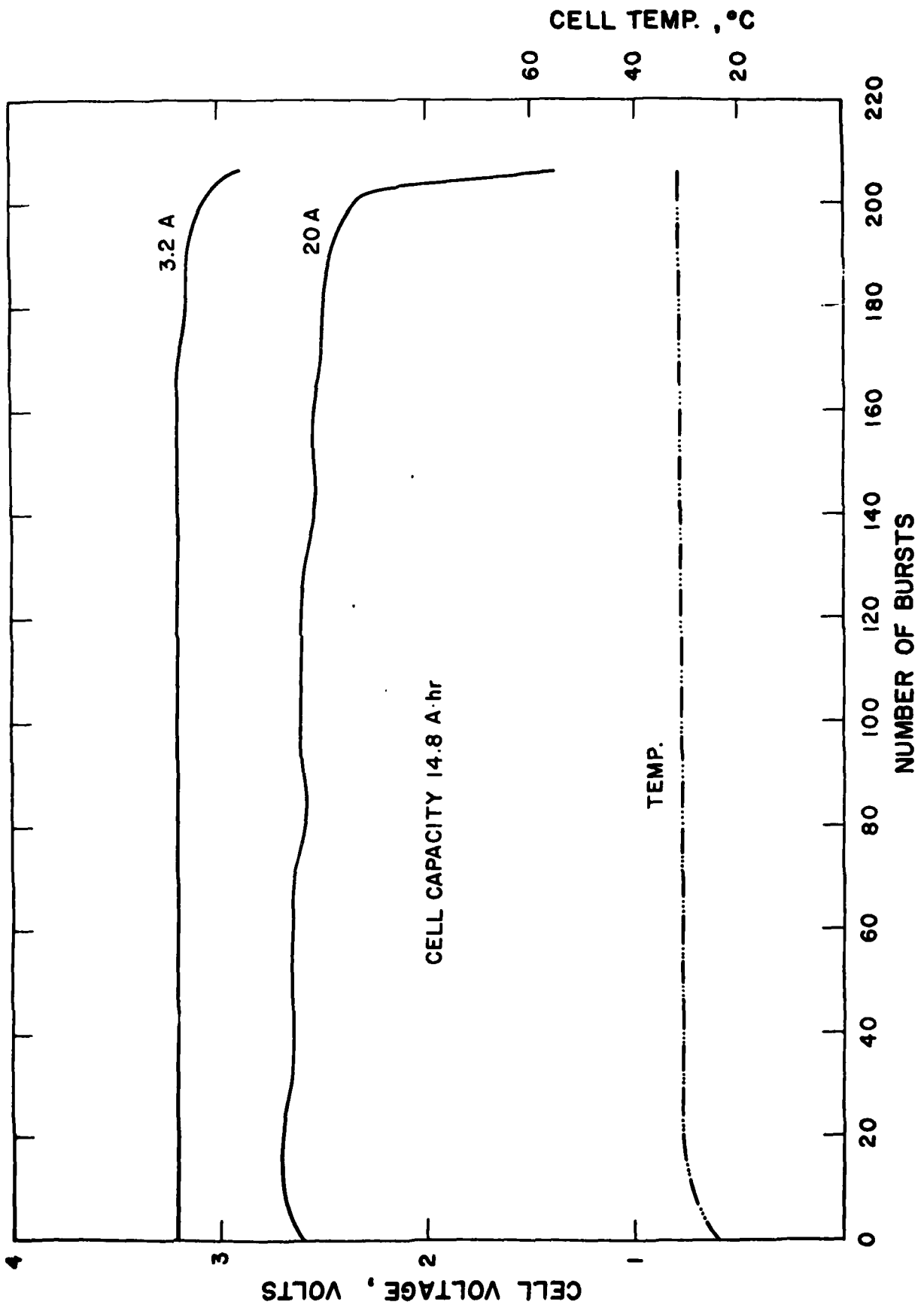

Fig. 7. Performance of a pair of D cells with cathode additive 2 at level C on the new GLLD test.

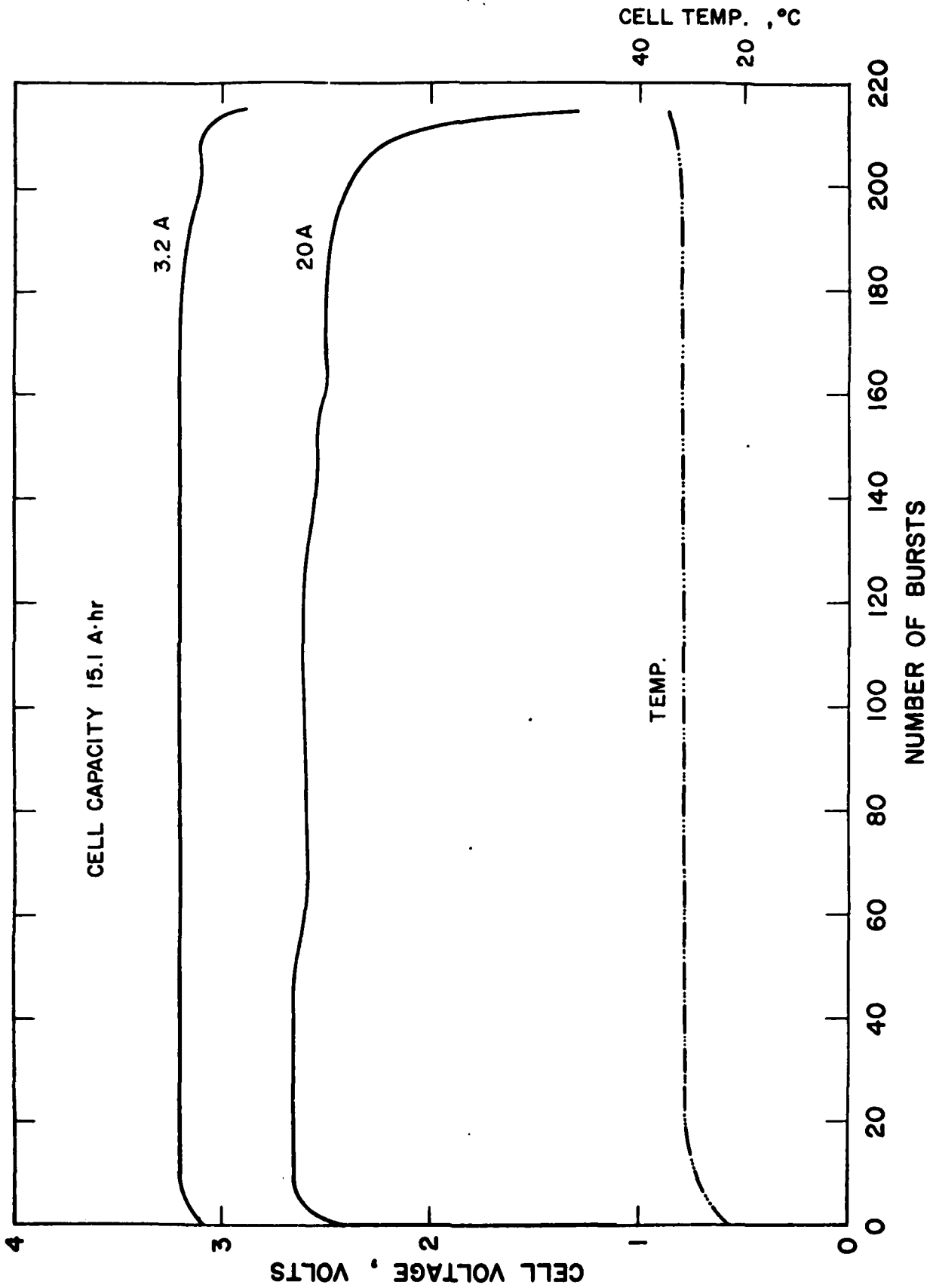

Fig. 8. Performance of a pair of D cells with cathode additive 2 at level C on the new GLID test.

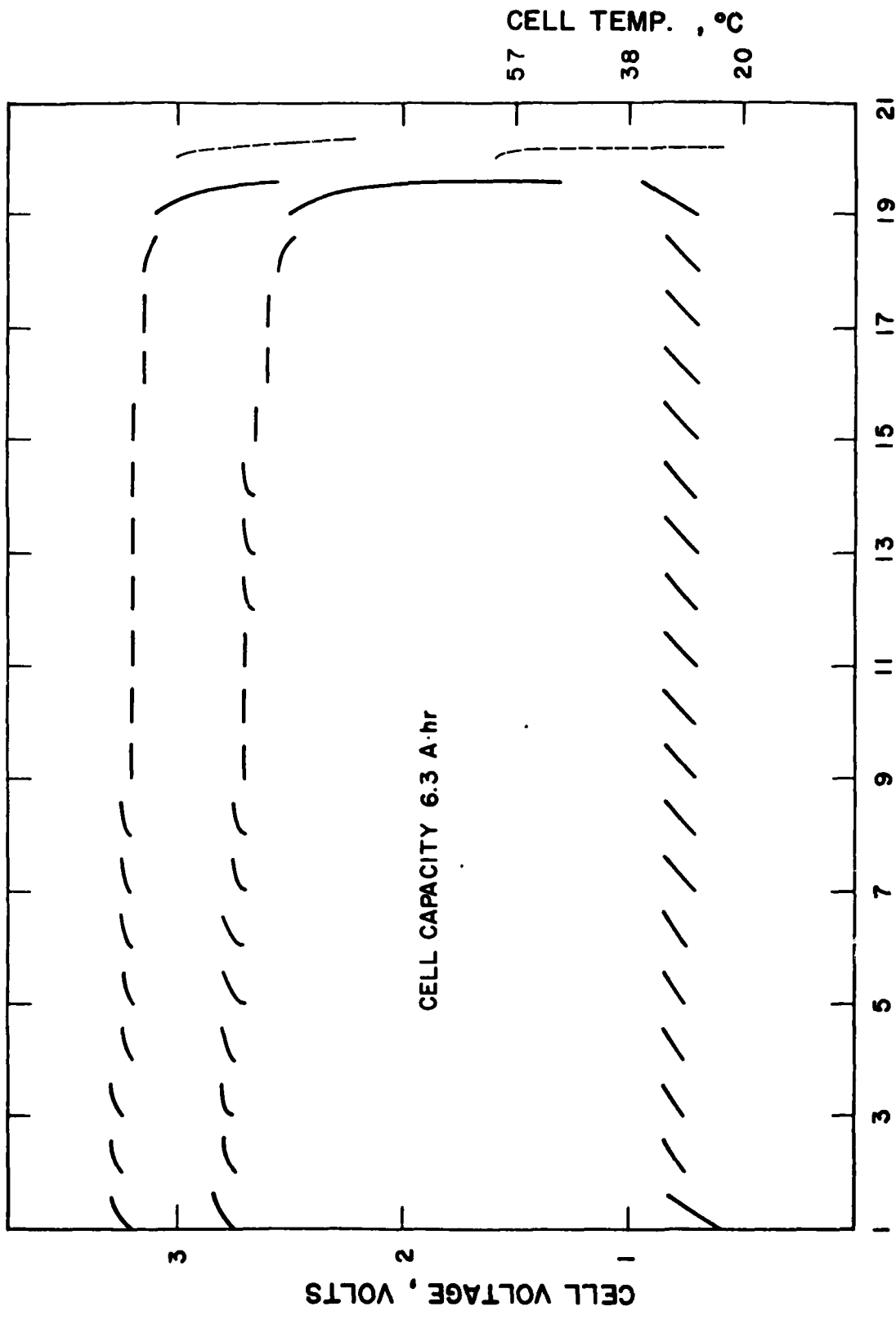

Fig. 9. Performance of a pair of D cells with cathode pretreatment on the GILD test.

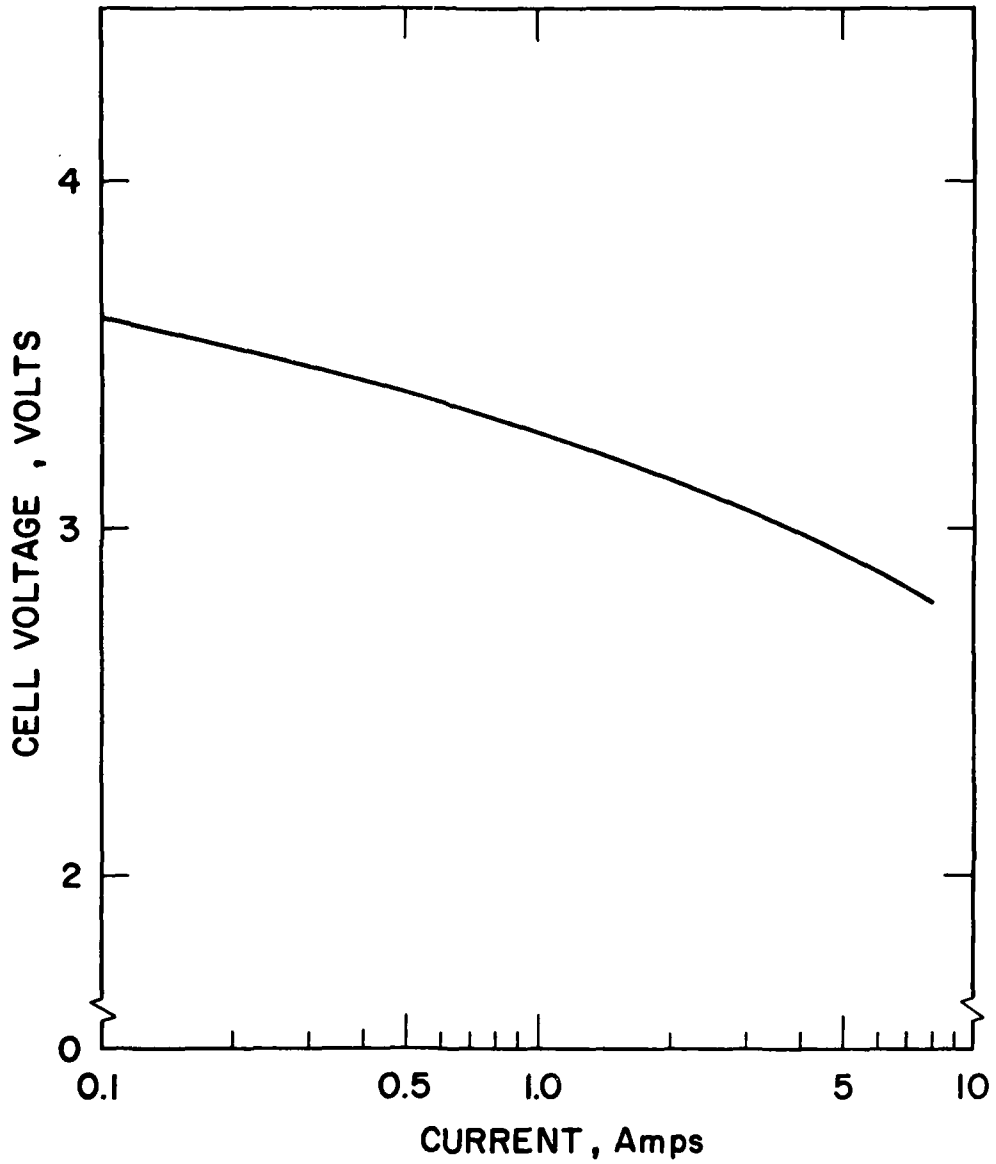

Fig. 10. Polarization curve for a D cell with 35" pretreated cathode.

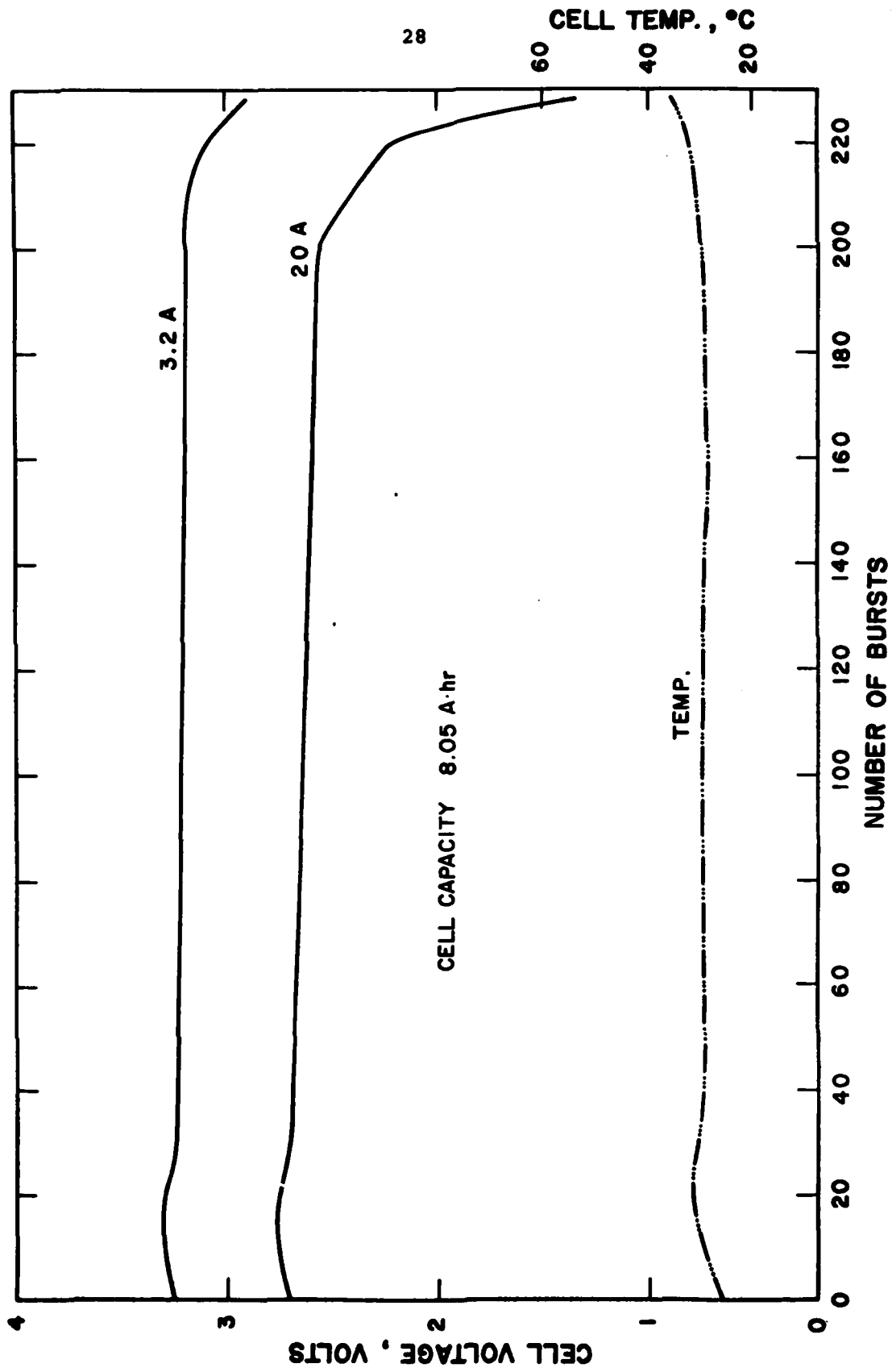

Fig. 11. Performance of a pair of D cells with 35" pretreated cathodes on the GLLD test.

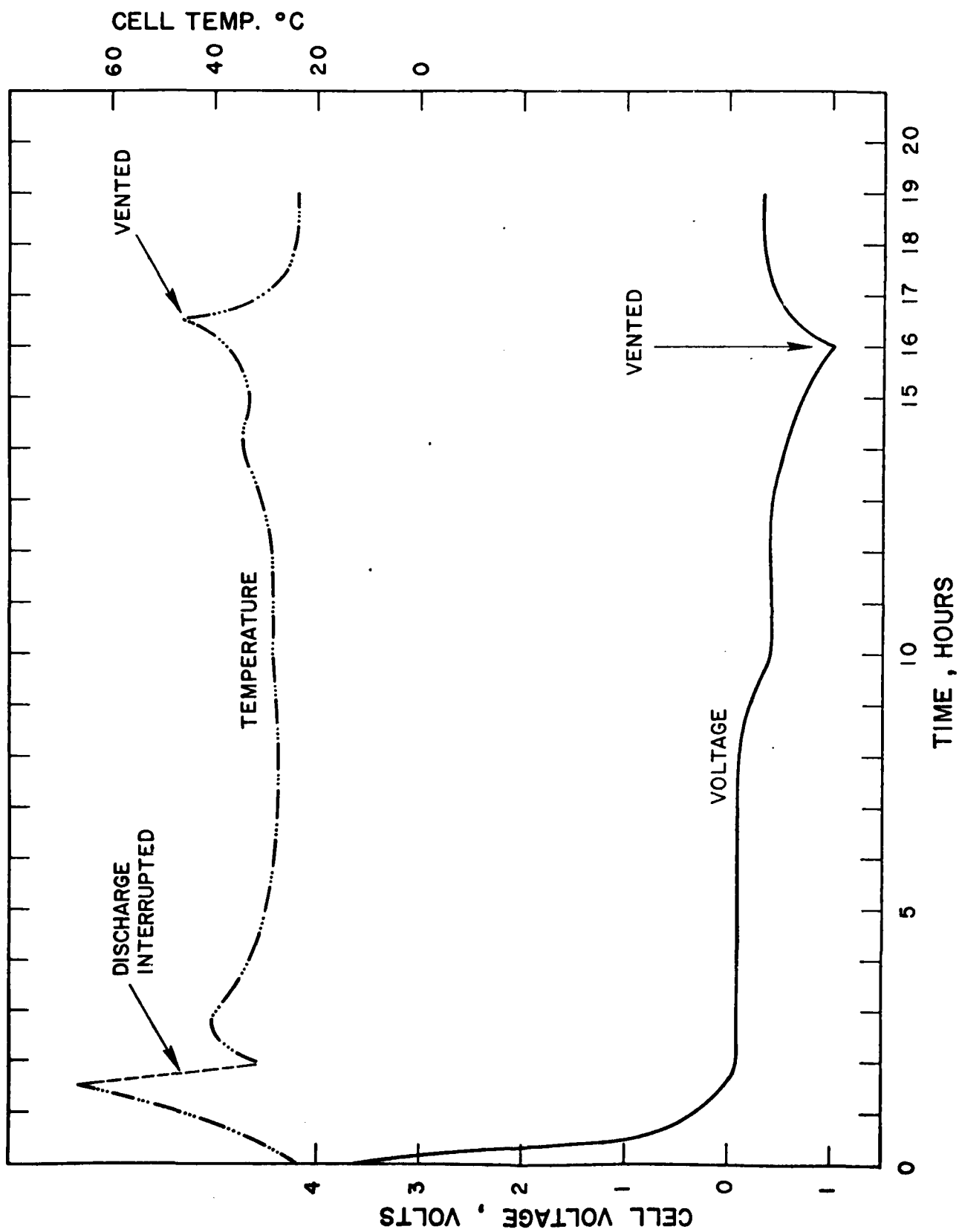

Fig. 12. Behavior of a pair of D cells with pretreated 35" cathodes during voltage reversal at 2A.

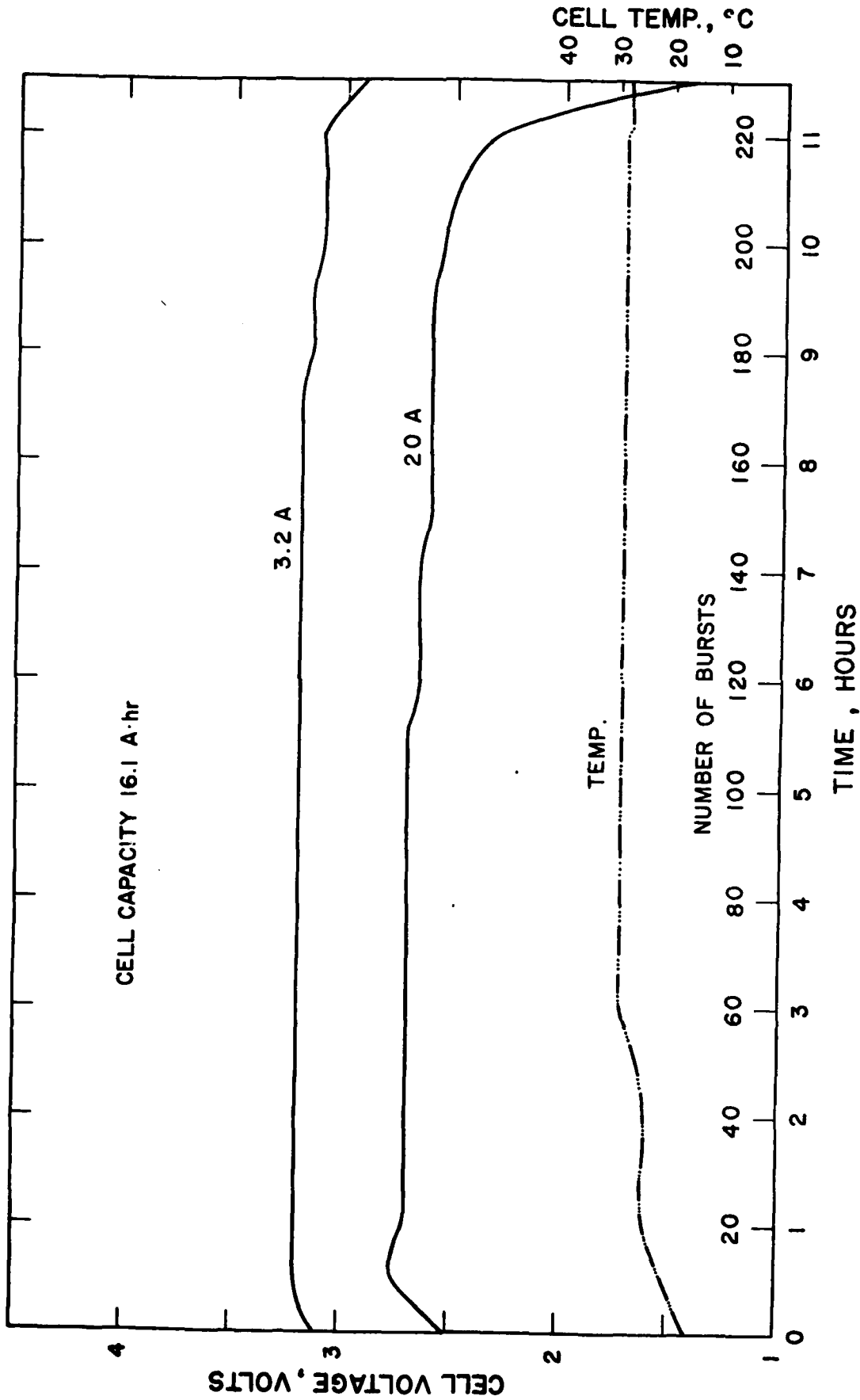

Fig. 13. Performance of a pair of D cells with 35" pretreated cathodes on the GLLD test.

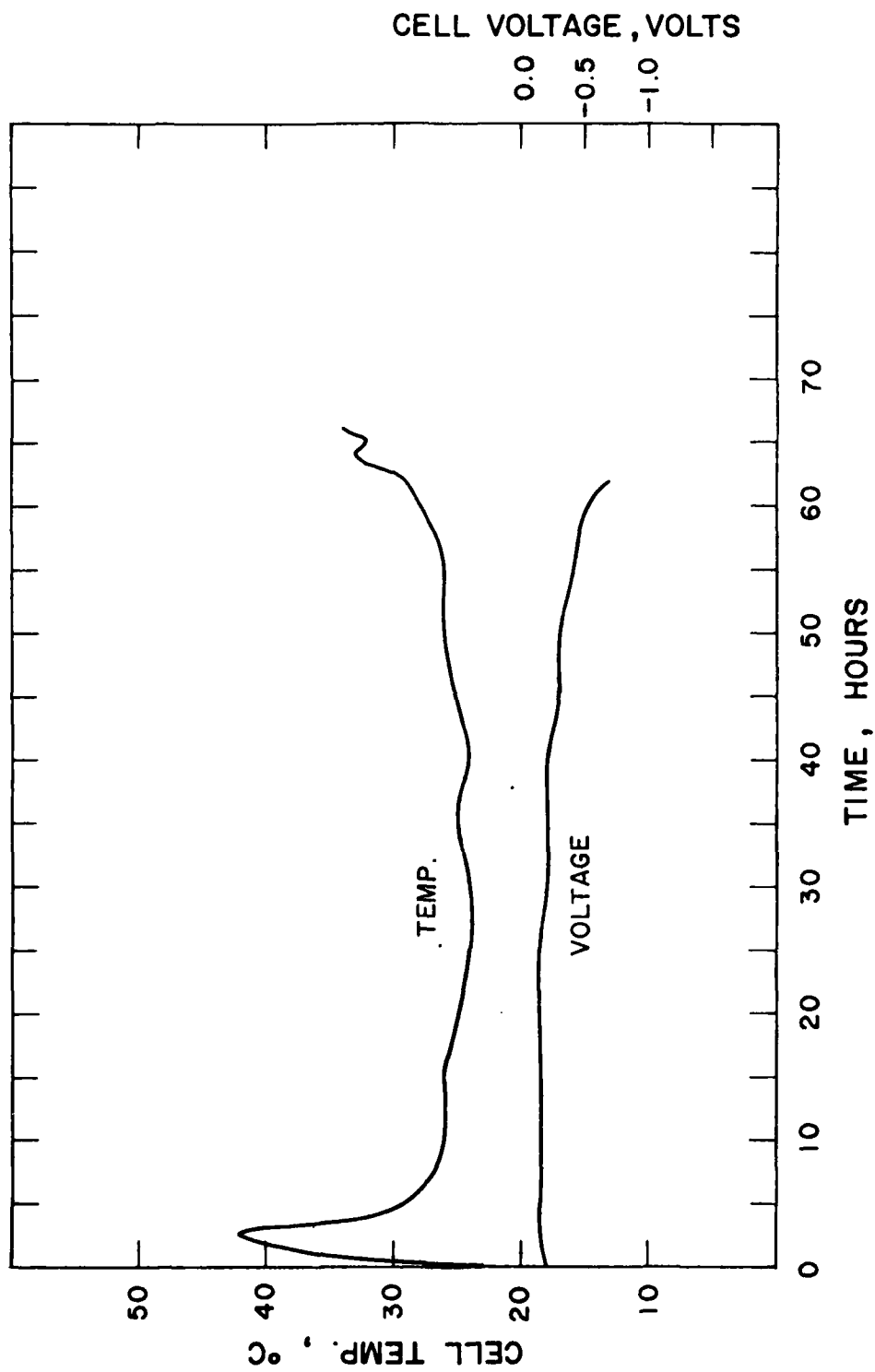

Fig. 14. Performance of a pair of resistively discharged D cells with 35" pretreated cathodes in reversal at 2A.

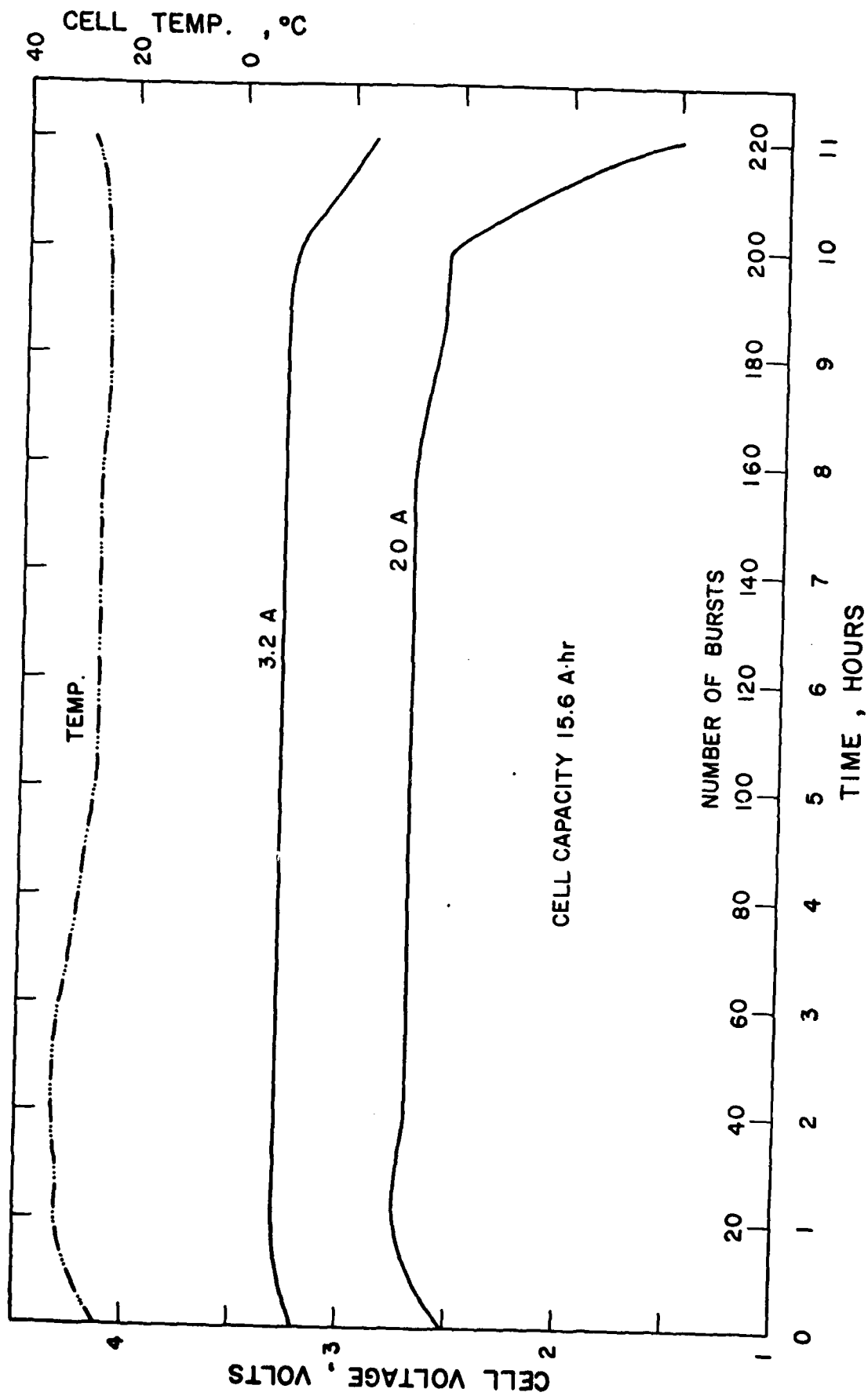

Fig. 15. Performance of a pair of D cells with 40" pretreated cathodes on the GLLD test.

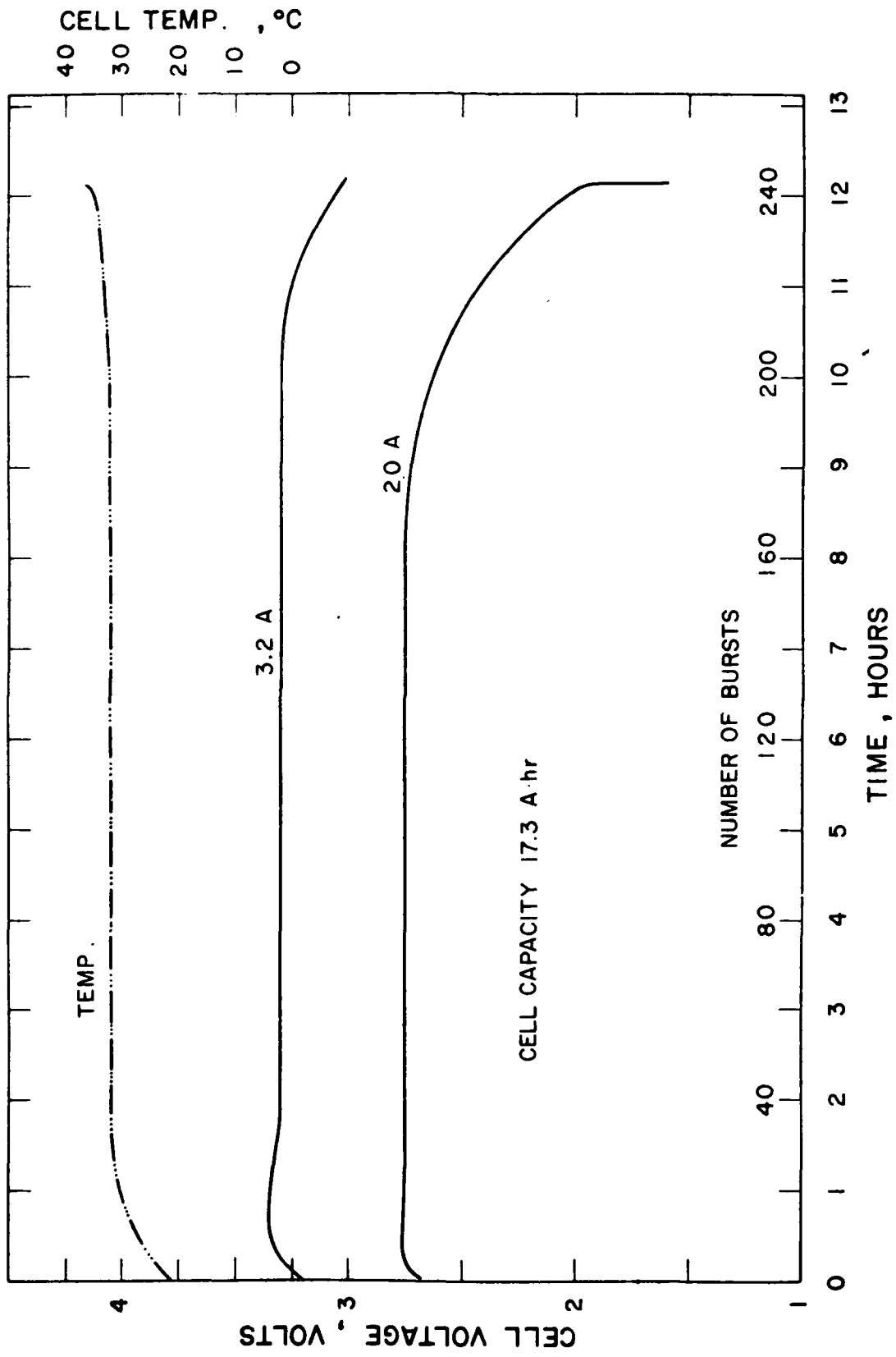

Fig. 16. Performance of a pair of cells with 40" pretreated cathodes on the GLLD test.

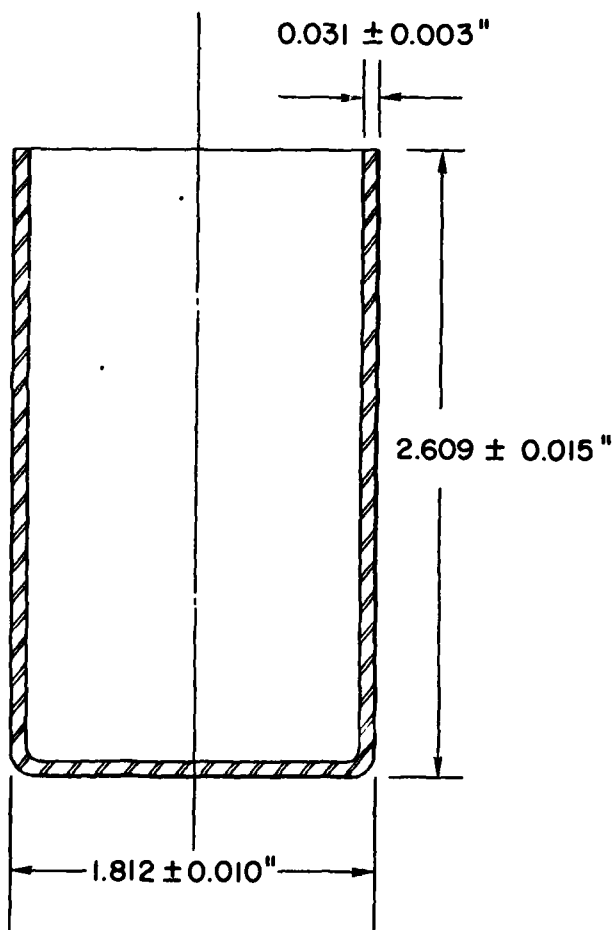

Fig. 17. Schematic diagram of the stainless steel can for the 1.8 inch diameter spirally wound cylindrical cell.

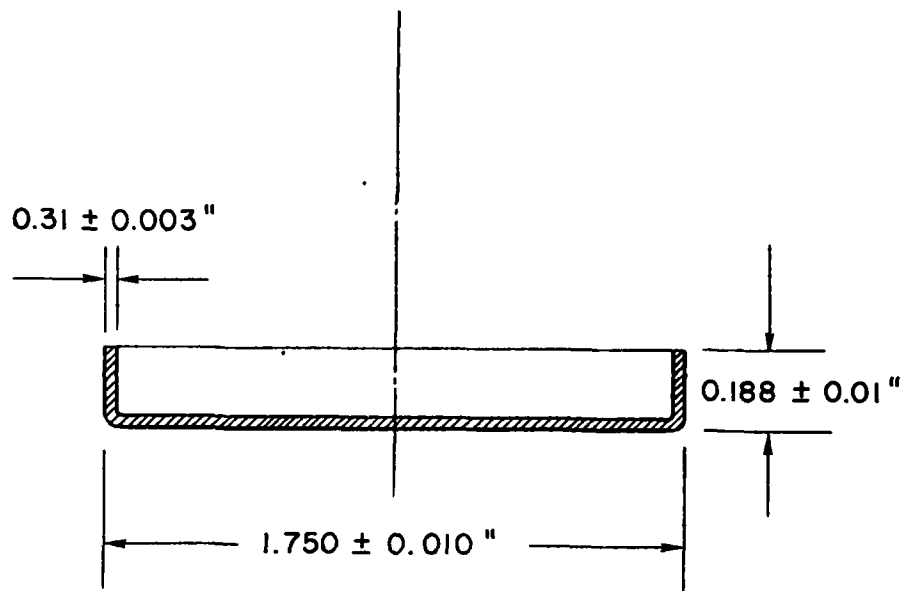

Fig. 18. Schematic drawing of the Kovar cell top for the 1.8 inch diameter cylindrical cell.

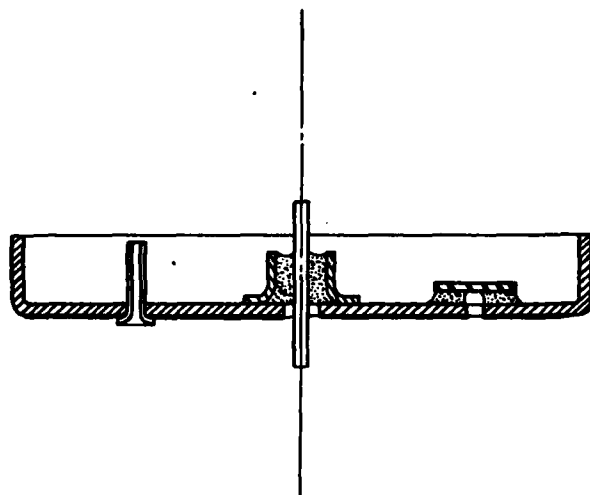

Fig. 19. Schematic drawing of the completer 1.8 inch diameter cell top with fill port, vent and G/M feedthrough.

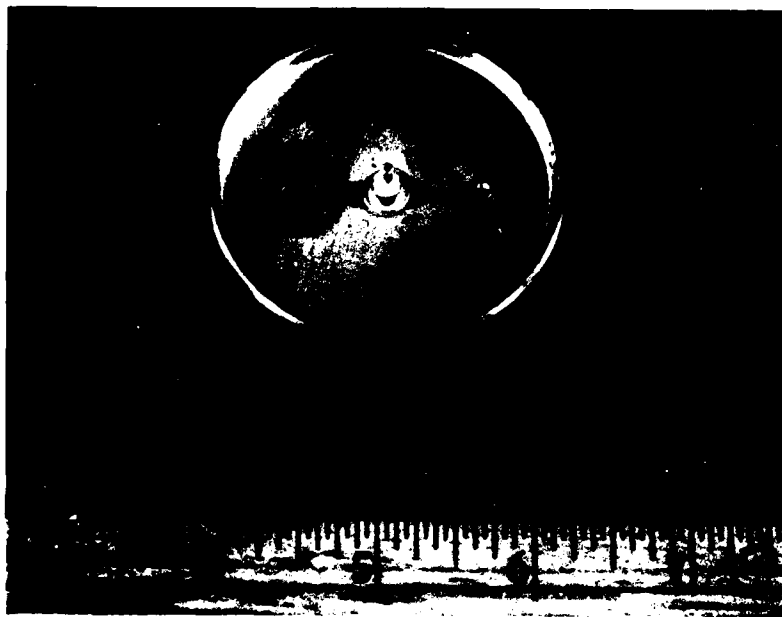

Fig. 20. Photograph of the finished 1.8 inch diameter cylindrical cell.

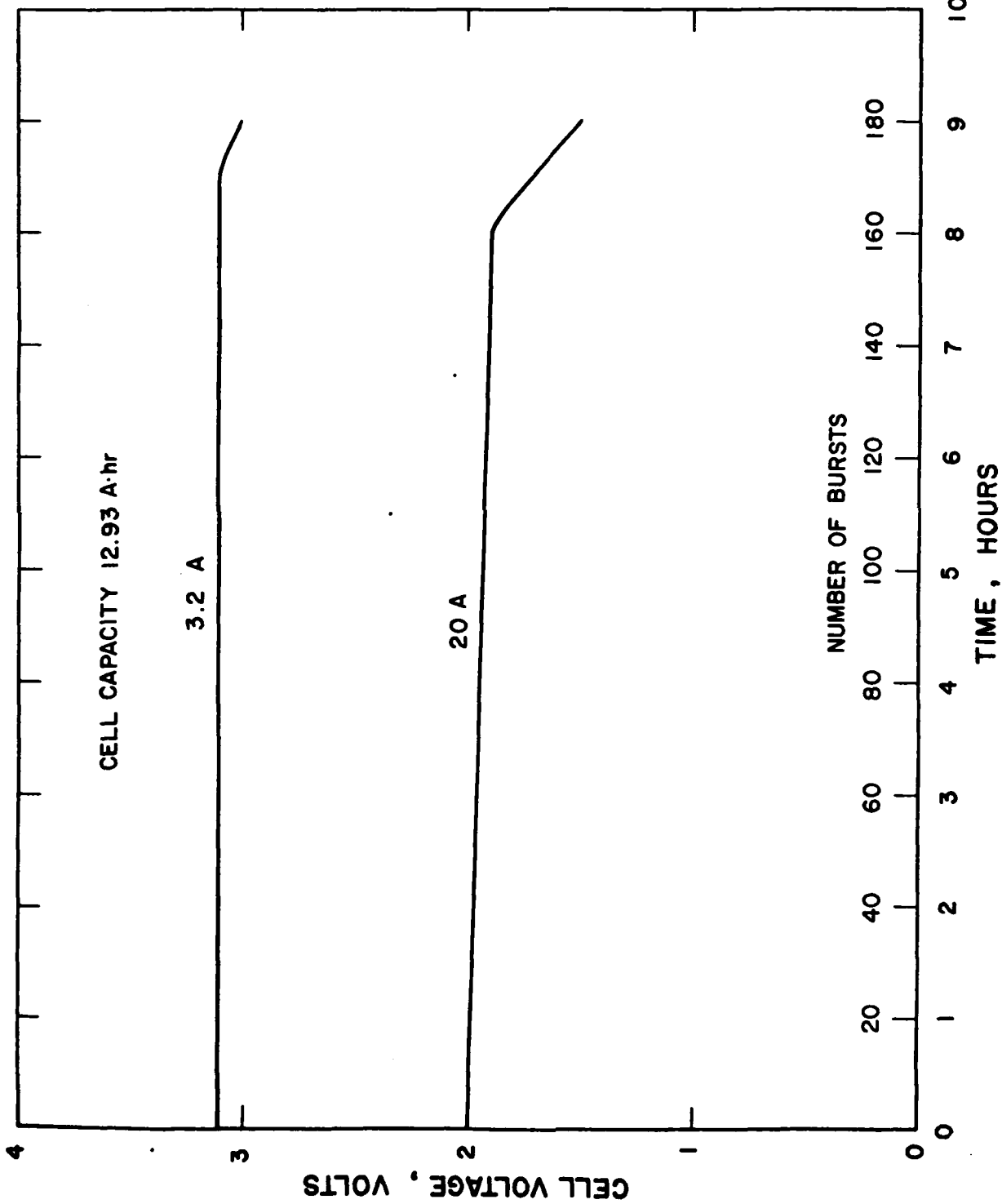

Fig. 21. Performance of a 1.8 inch diameter cylindrical cell on the old GLLD test cycle.

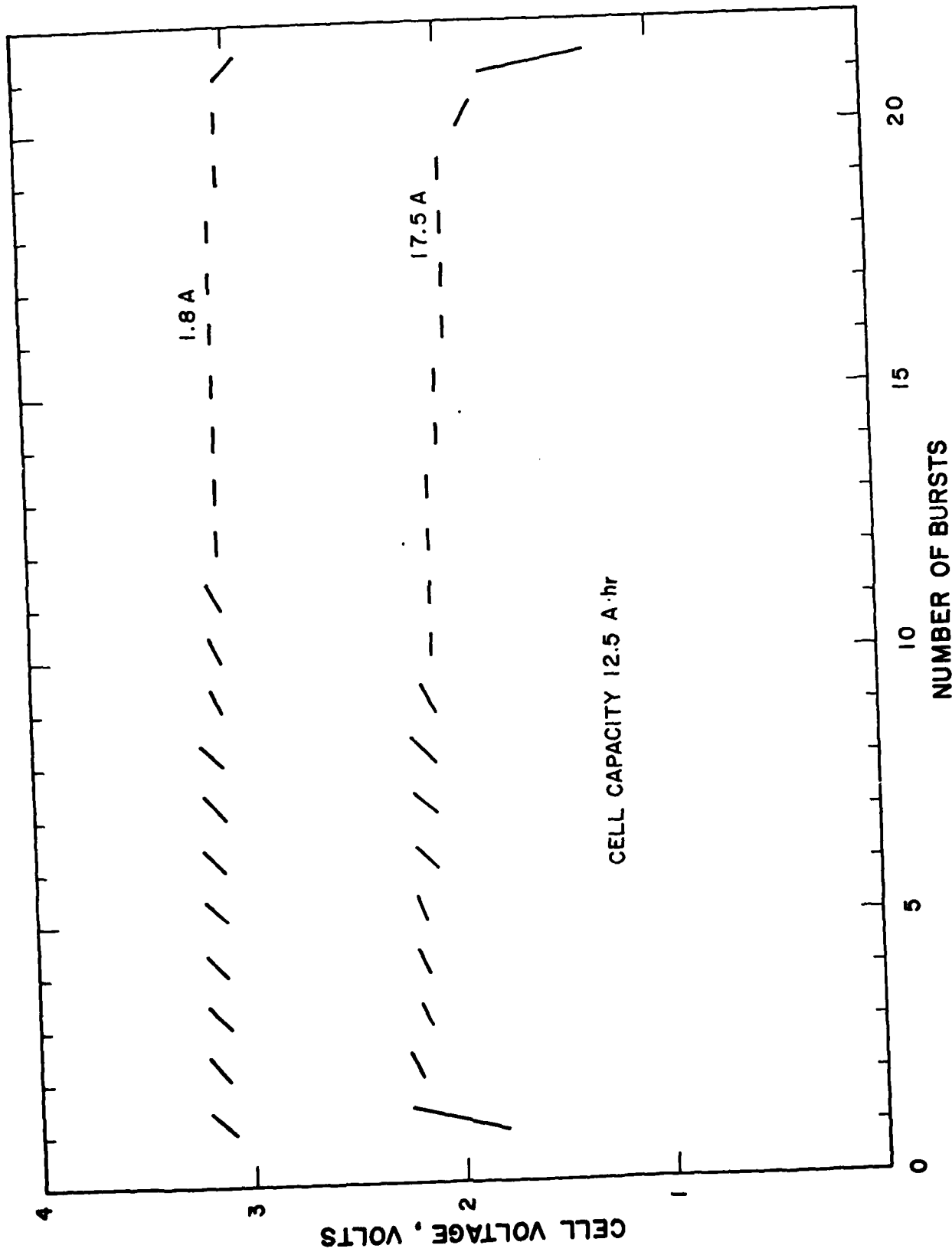

Fig. 22. Performance of a 1.8 inch diameter cylindrical cell on the new GLLD test cycle.

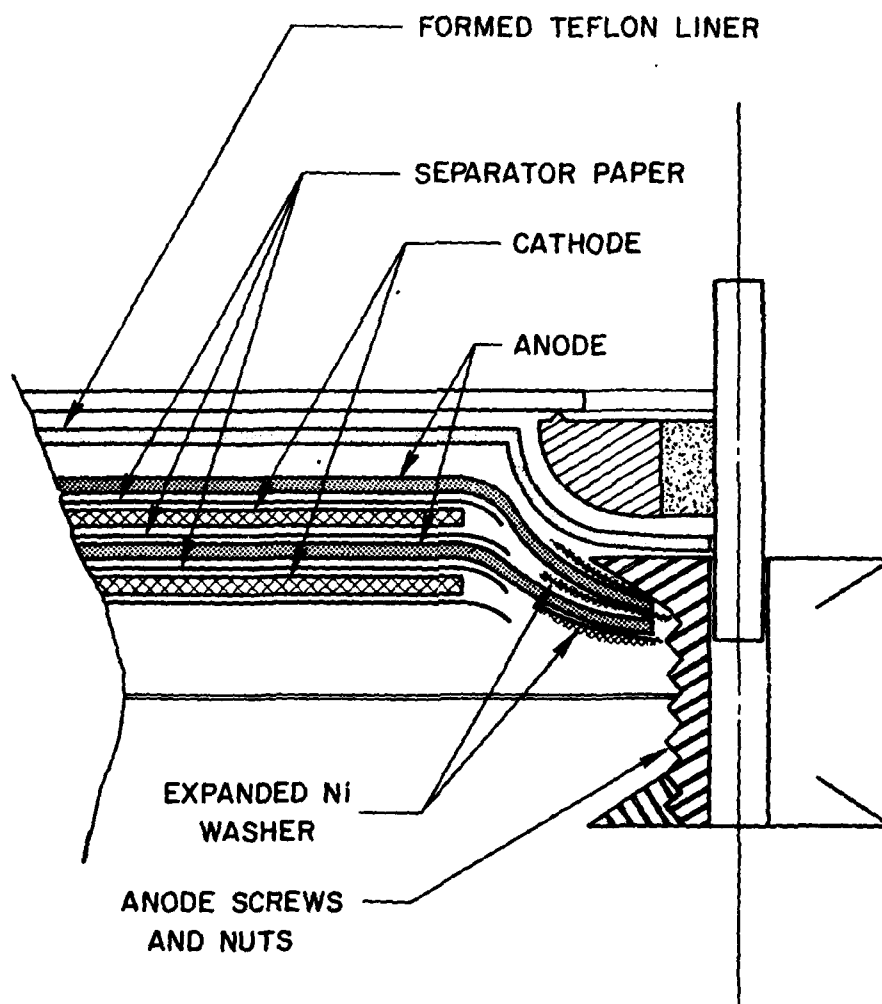

Fig. 23. Schematic drawing of the interior of a flat cylindrical cell.

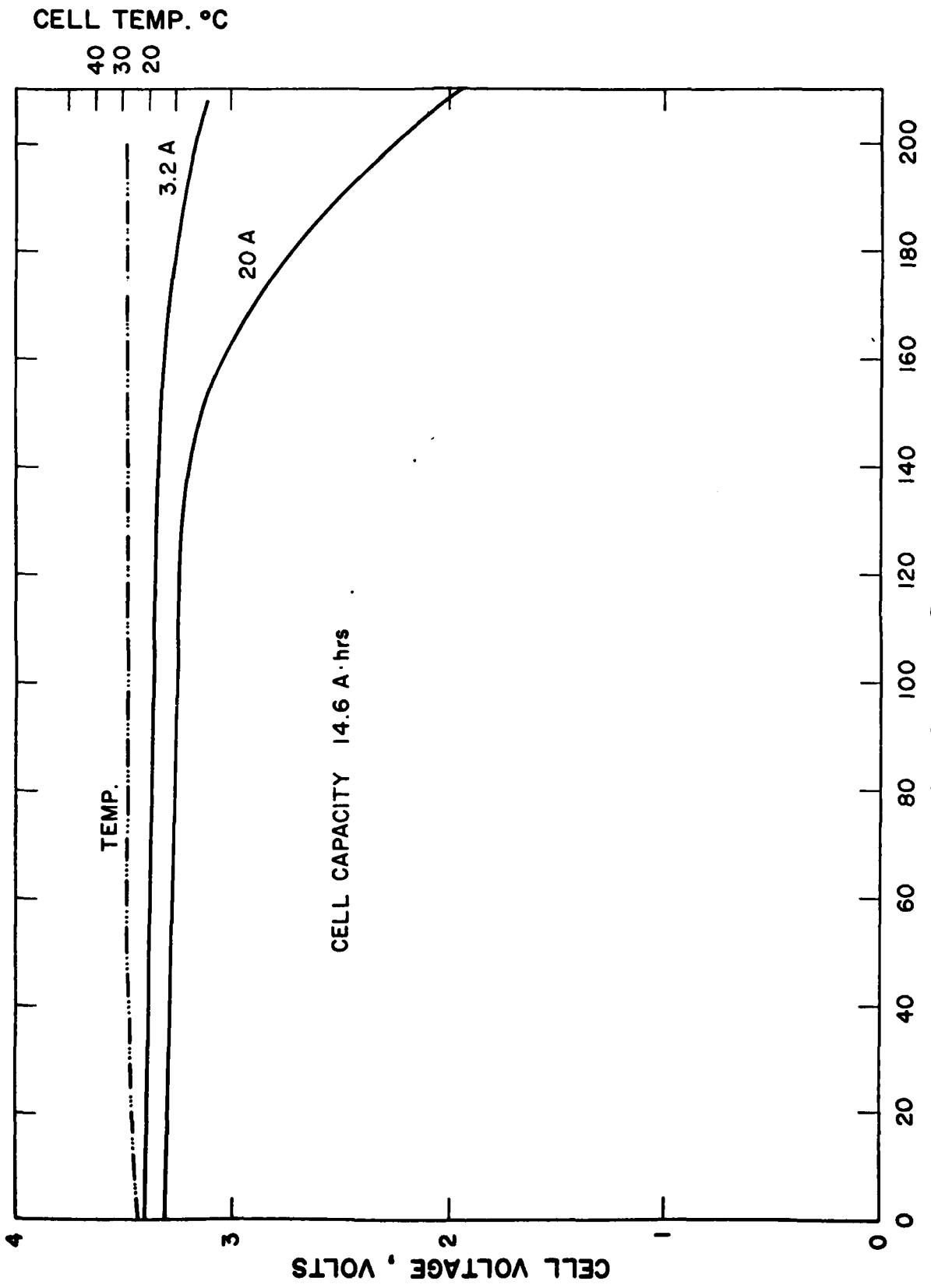

Fig. 24. Performance of a flat cell with double anodes on the GLLD test.

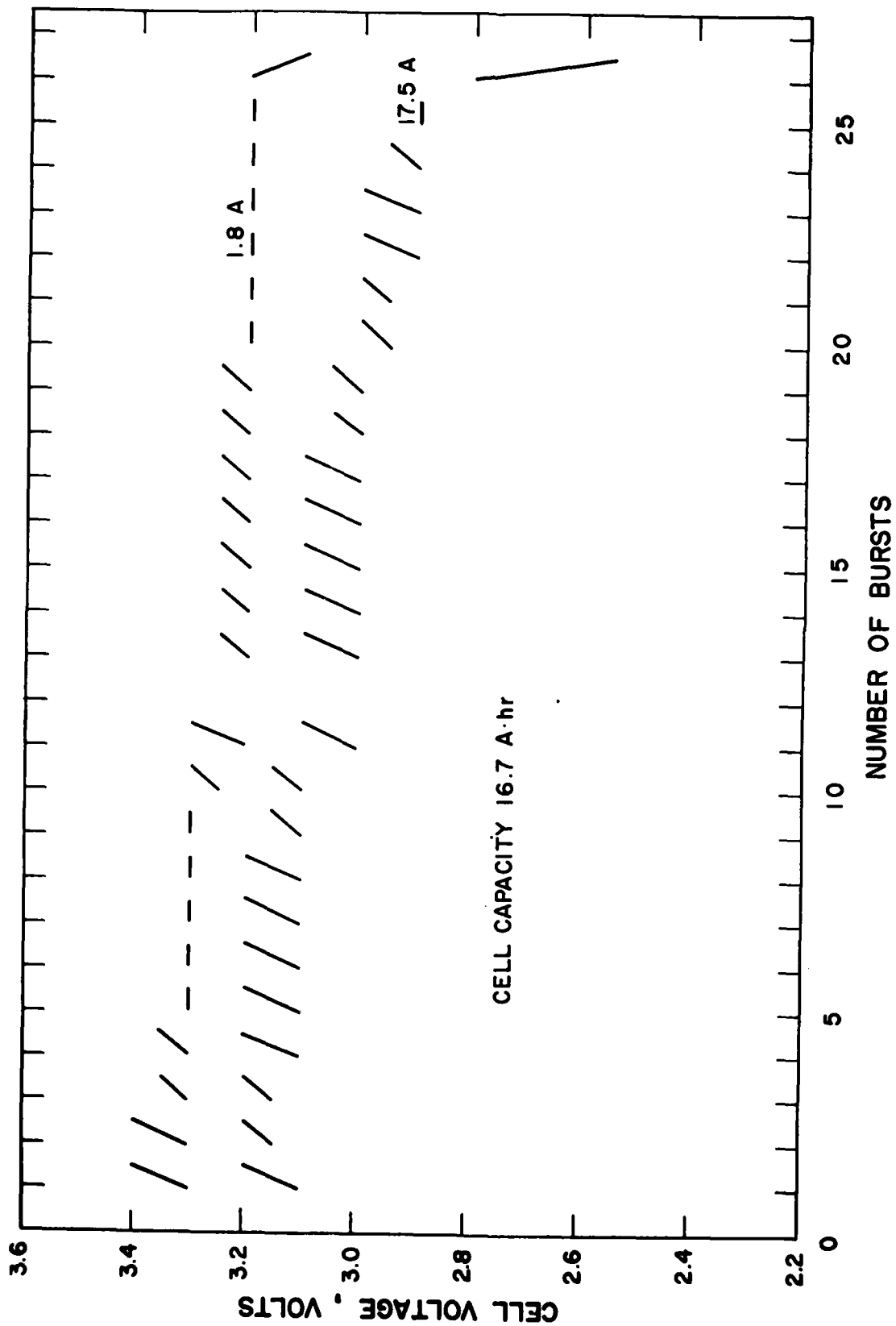

Fig. 25. Performance of a flat cell with 32 cathodes on the old GLLD test cycle.

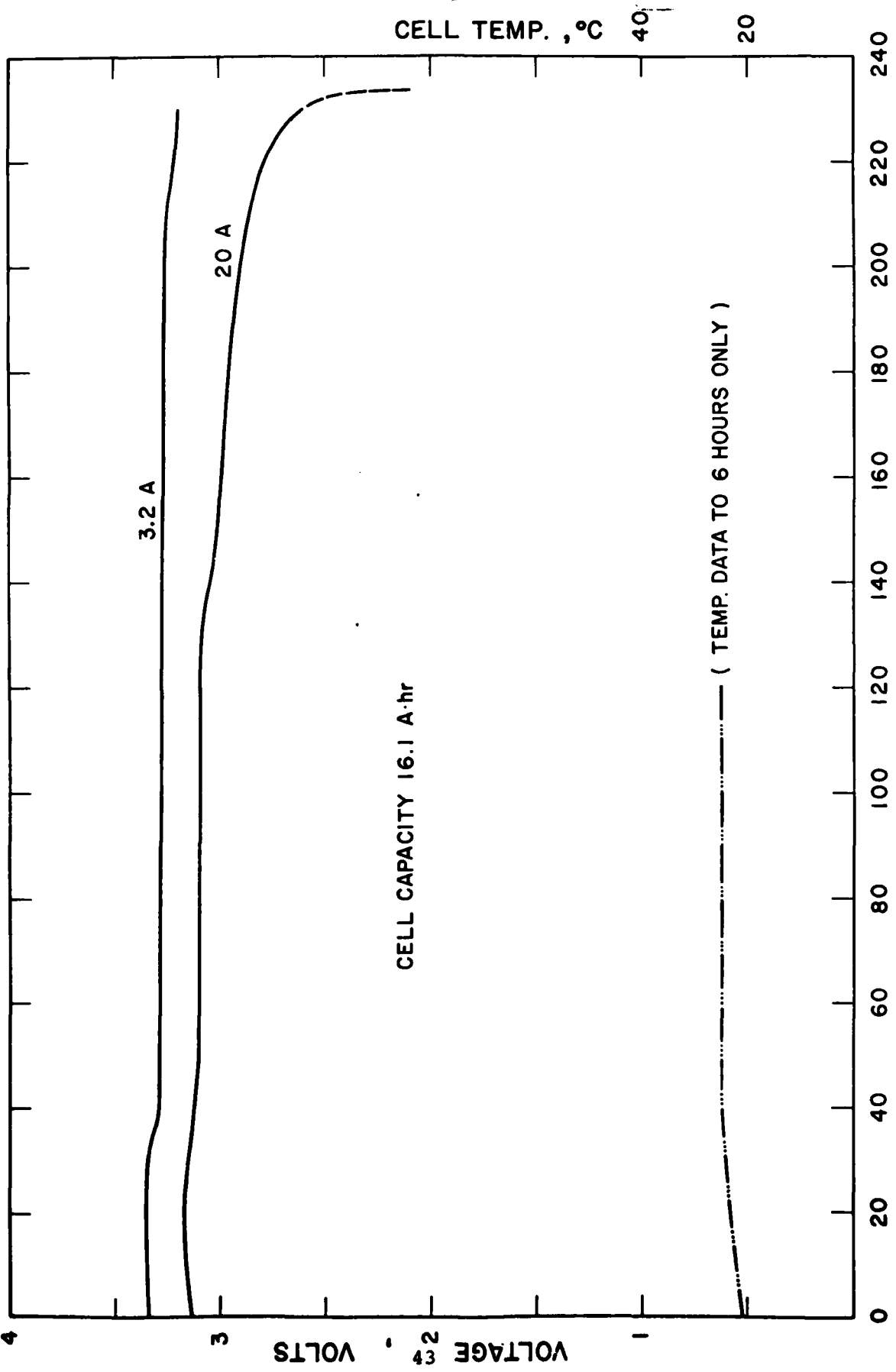

Fig. 26. Performance of a flat cell with 32 cathodes on the new GLLD test cycle.

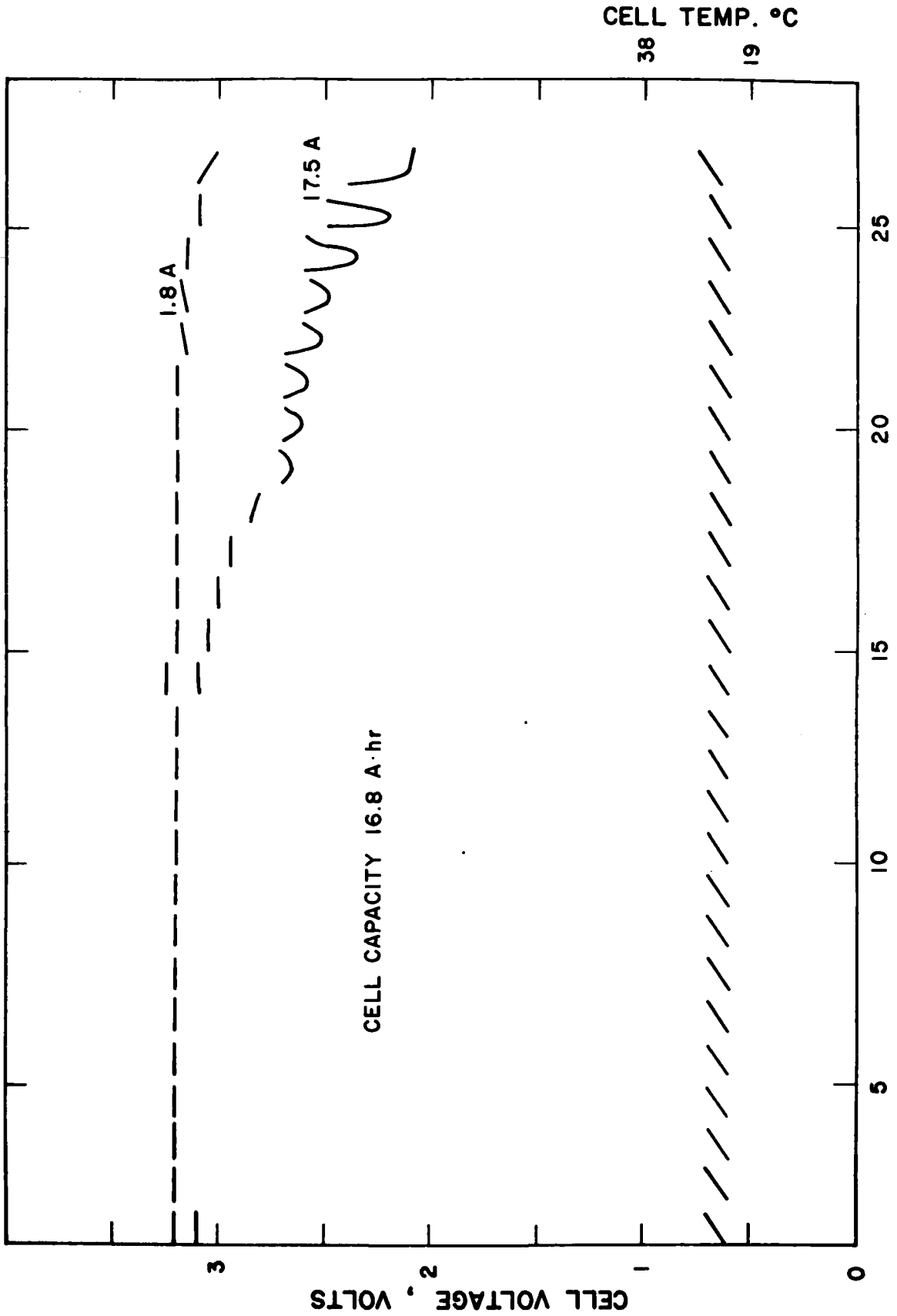

Fig. 27. Performance of a flat cell with 40 cathodes on the old GLLD test.

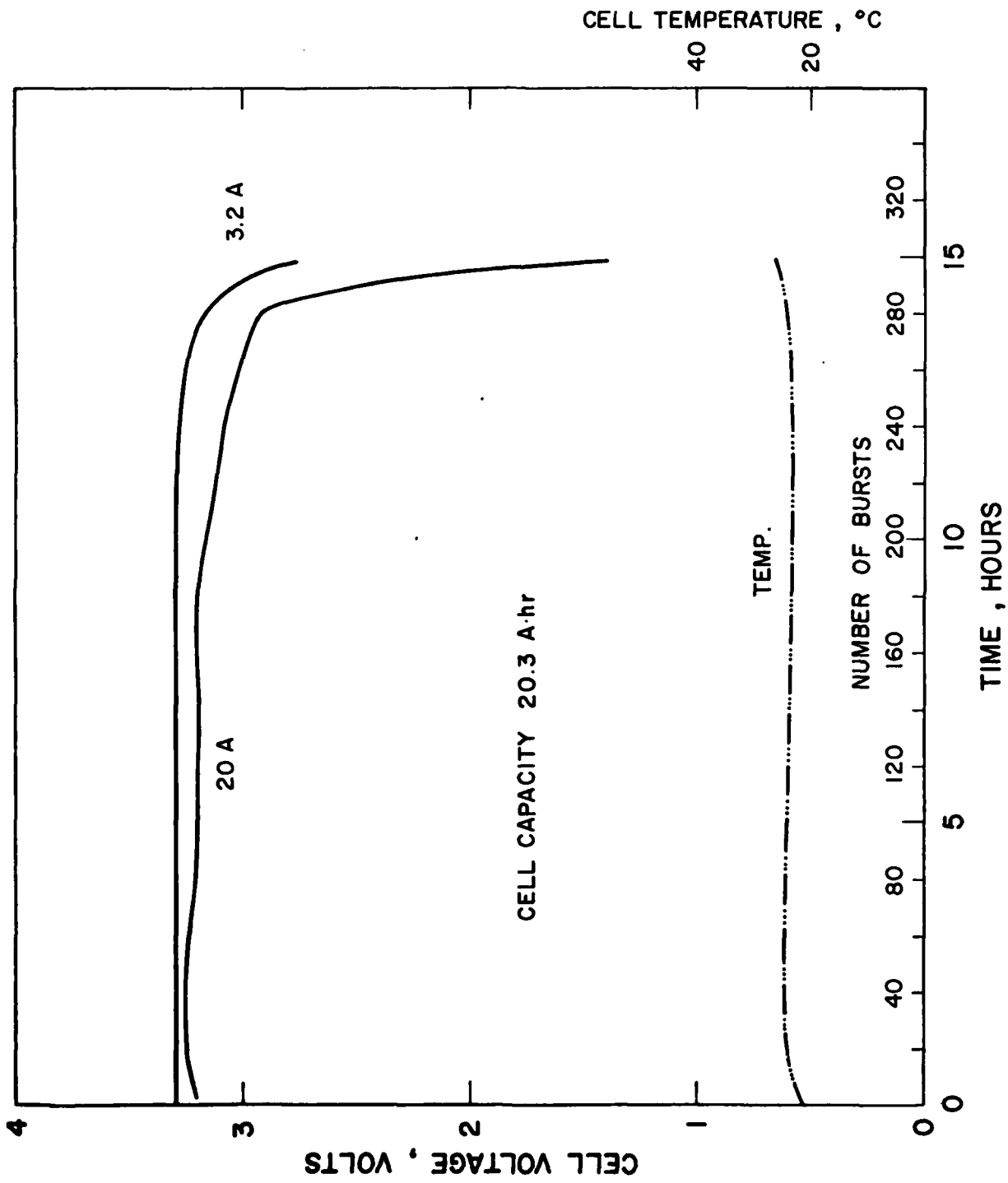

Fig. 28. Performance of a flat cell with 36 cathodes on the new GLLD test.

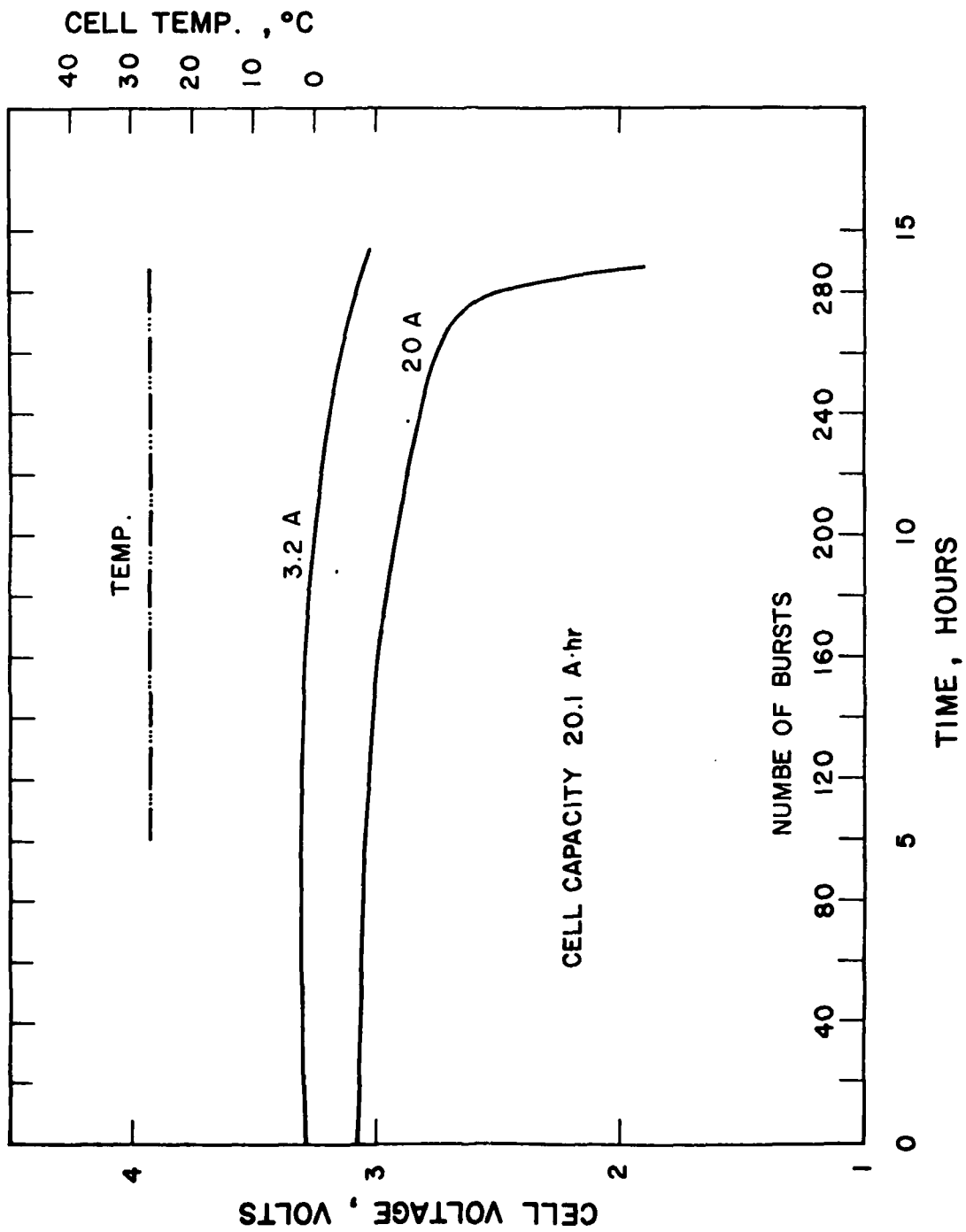

Fig. 29. Performance of a flat cell with 36 cathodes on the new GILD test.

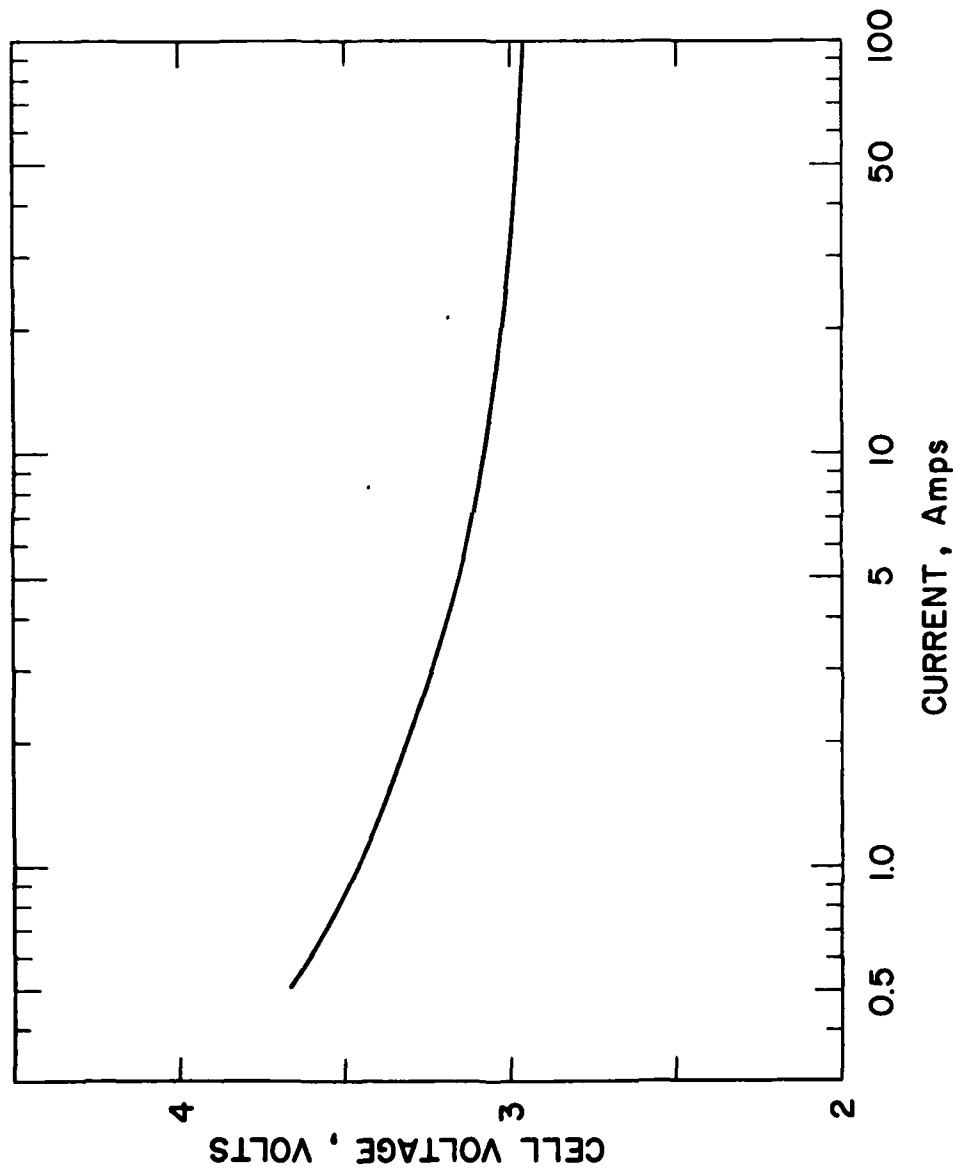

Fig. 30. Current-voltage curve for a flat cylindrical cell.

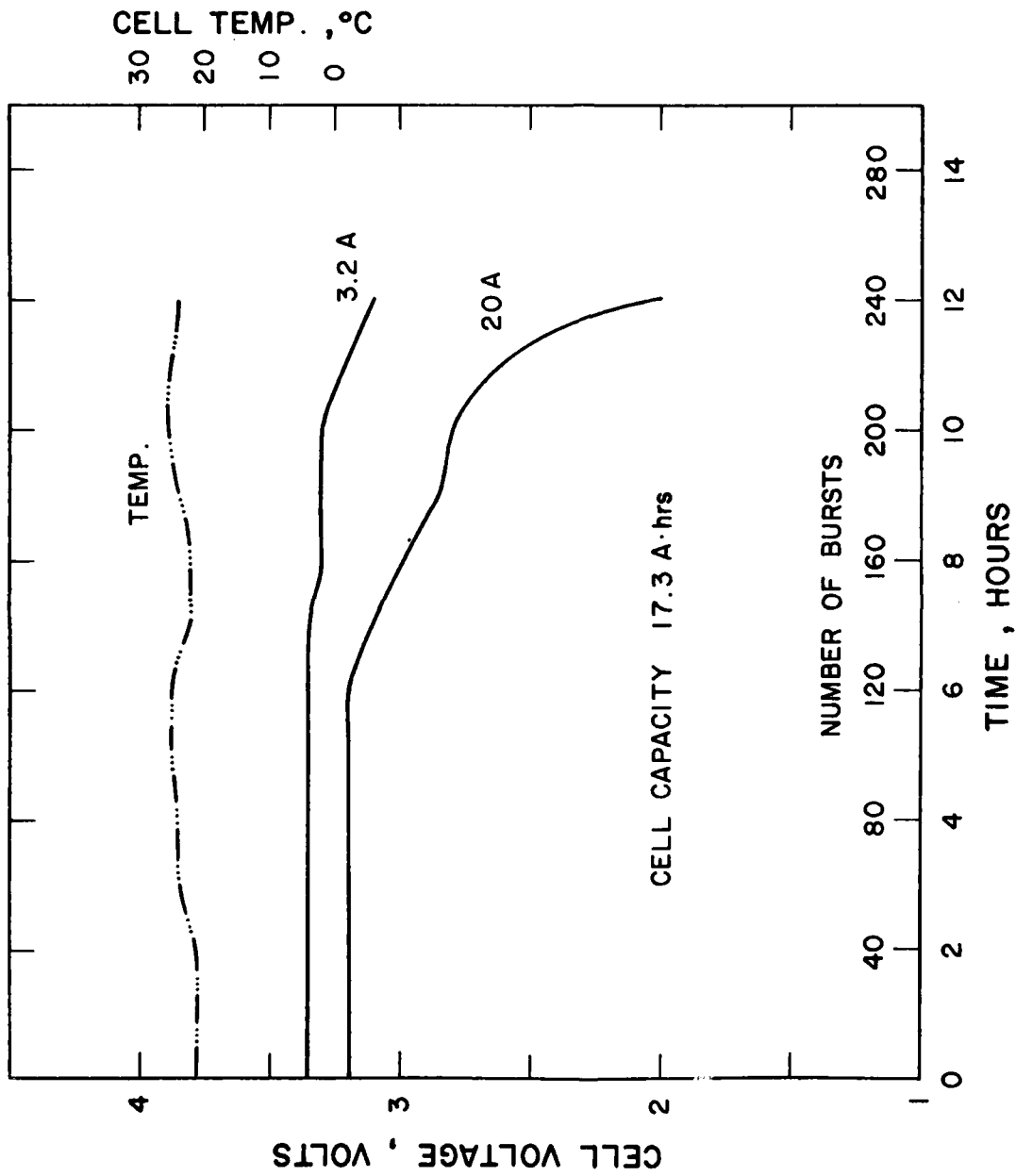

Fig. 31. Performance of the flat cell from Fig. 30 on the GILD test.

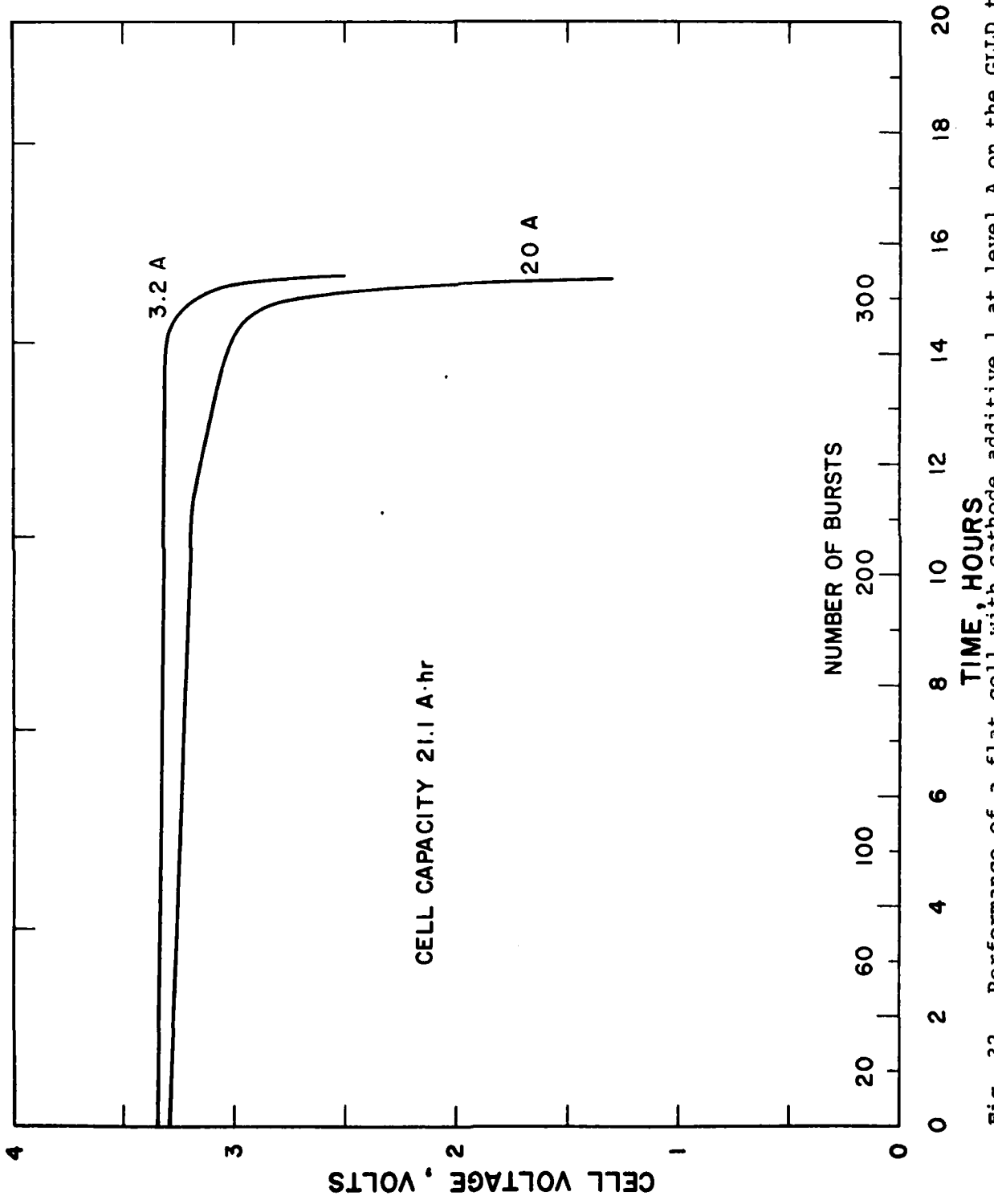
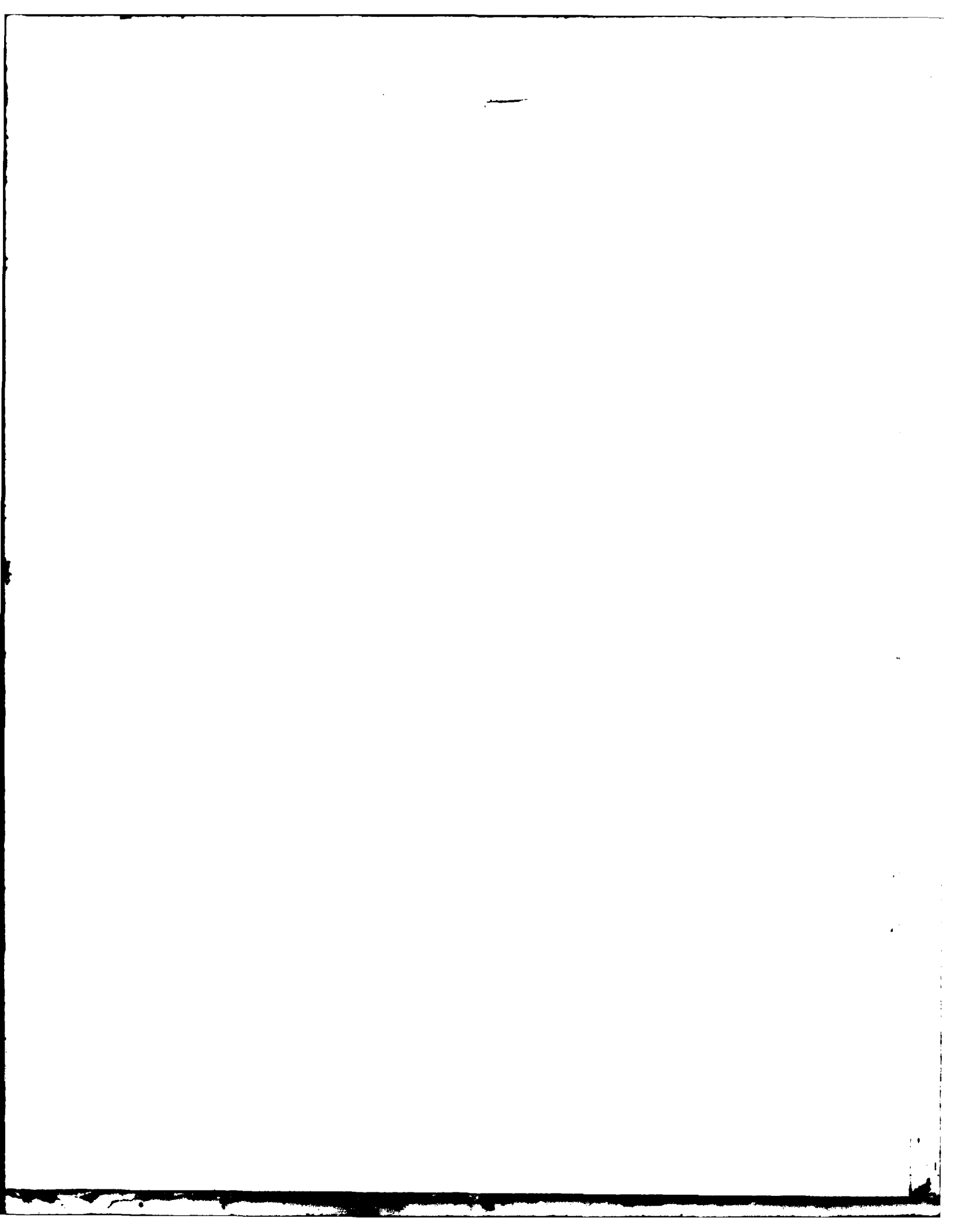

Fig. 32. Performance of a flat cell with cathode additive 1 at level A on the GLLD test.



13 November 1979

ELECTRONICS TECHNOLOGY AND DEVICES LABORATORY

MANDATORY CONTRACT DISTRIBUTION LIST

Defense Technical Information Center (12) ATTN: DTIC-TCA Cameron Station (Bldg 5) Alexandria, VA 22314	Cdr, Night Vision & Electro- (1) Optics ERADCOM ATTN: DELNV-D Fort Belvoir, VA 22060
GIDEP Engineering & Support Dept. (1) TE Section PO Box 398 Norco, CA 91760	Cdr, Atmospheric Sciences (1) Lab ERADCOM ATTN: DELAS-SY-S White Sands Missile Range, NM 88002
Director (1) Naval Research Laboratory ATTN: CODE 2627 Washington, DC 20375	Cdr, Harry Diamond Lab. (1) ATTN: DELHD-CO, TD (In Turn) 2800 Powder Mill Road Adelphi, MD 20783
Rome Air Development Center (1) ATTN: Documents Library (TILD) Griffis AFB, NY 13441	Cdr, ERADCOM (1) ATTN: DRDEL-CG, CD, CS (In Turn) 2800 Powder Mill Road Adelphi, MD 20783
Deputy for Science & Technology (1) Office, Asst. Sec. Army (R&D) Washington, DC 20310	Cdr, ERADCOM (1) ATTN: DRDEL-CT 2800 Powder Mill Road Adelphi, MD 20783
HQDA (DAMA-ARZ-D/Dr. F.D. Verderame) (1) Washington, DC 20310	Commander US Army Electronics R&D Command Fort Monmouth, NJ 07703
Director US Army Material Systems Analysis Actv (1) ATTN: DRXSY-MP Aberdeen Proving Ground, MD 21005	DELET-P (1) DELEW-D (1) DELET-DD (1) DELS-D-L (Tech Library) (1) DELS-D-L-S (STINFO) (2) Originating Office DELET-PR (5)
Commander, DARCOM (1) ATTN: DRCDE 5001 Eisenhower Avenue Alexandria, VA 22333	Commander (1) US Army Communications R&D Command ATTN: USMC-LNO Fort Monmouth, NJ 07703
Cdr, US Army Signals Warfare Lab (1) ANNT: DELSW-OS Vint Hill Farms Station Warrenton, VA 22186	Advisory Group on Electron Devices (2) 201 Varick Street, 9th Floor New York, NY 10014
Cdr, PM Concept Analysis Centers (1) ATTN: DRCPM-CAC Arlington Hall Station Arlington, VA 22212	

Distribution List - Continued

Electrochimica 2485 Charleston Road Mountain View, CA 94049 ATTN: Dr. Eisenberg	(1)	Mr. J. R. Moden Energy Conversion Branch Code 3642 Naval Underwater Systems Center Newport Laboratory Newport, RI 02840	(1)
Dr. Hugh Barger P. O. Box 2232 Davidson, NC 28036	(1)	NASA Lewis Research Center Mail Stop 6-1 21000 Brookpark Road Cleveland, OH 44135 ATTN: Dr. Stuard Fordyce	(1)
Energy Storage & Conversion Dept. TRW Systems One Space Park Redondo Beach, CA 90278	(1)	Mr. Joe McCartney Naval Undersea Center Code 608 San Diego, CA 92132	(1)
Sanders Associates, Inc. 24 Simon Street Mail Stop NSI-2208 Nashua, NH 03060 ATTN: J. Marshall	(1)	EIC, Inc. ATTN: S. B. Brummer Newton, MA 02158	(1)
Power Conversion, Inc. 70 MacQuesten Pkwy Mount Vernon, NY 10550 ATTN: Stuart Chodosh	(1)	Altus Corp. 440 Page Mill Road Palo Alto, CA 94306 ATTN: Douglas Glader	(1)
Dr. D. Pouli Portfolio Manager Hooker Chemicals & Plastics Corp. M.P. O. Box 8 Niagara Falls, NY 14302	(1)	J. Bene MS 488 NASA Langley Research Center Hampton, VA 23665	(1)
Dr. Leonard Nanis G207 S.R.I. Menlo Park, CA 94025	(1)	Mr. Eddie T. Seo Research and Development Div. The Gates Rubber Co. 999 S. Broadway Denver, CO 80217	(1)
Dr. J. J. Auburn, Rm 1A-317 Bell Laboratories 600 Mountain Ave. Murray Hill, NJ 07974	(1)	Mr. Sidney Gross Mail Stop 8C-62 Boeing Aerospace Company P. O. Box 3999 Seattle, WA 98124	(1)
Stonehart Associates, Inc. 34 Five Fields Road Madison, CT 06443 ATTN: Mr. Thomas Reddy	(1)	Honeywell Technology Center ATTN: Dr. H. V. Venkatesetty 10701 Lyndale Avenue South Bloomington, MN 55420	(1)
Jet propulsion Laboratory 4800 Oak Grove Drive Pasadena, California 91103 ATTN: Mr. Harvey Frank Mail Stop 198-220	(1)	Mr. Aiji Uchiyama Jet Propulsion Laboratory - M.S. 198-220 4800 Oak Grove Drive Pasadena, CA 91103	(1)
Dr. D. Ernst Naval Surface Weapons Center White Oak Laboratory, Code R-33 (M/S A026) Silver Spring, MD 20910	(1)	Dr. Frank Bis Naval Surface Weapons Center White Oak Laboratory, Code R-33 Silver Spring, MD 20910	(1)

Distribution List Continued

Transportation Systems Center Kendall Square Cambridge, MA 02142 ATTN: Dr. Norman Rosenberg	(1)	GTE Sylvania, Inc. 77 A Street Needham Heights, MA 02194	(1)
GTE Laboratories, Inc. 40 Sylvan Road Waltham, MA 02154	(1)	General Motors Corp. Research Laboratories General Motors Technical Center 12 Mile and Mounds Roads Warren, MI 48090 ATTN: Dr. J. L. Hartman	(1)
Foote Mineral Company Route 100 Exton, PA 19341 ATTN: Dr. H. Grady	(1)	Union Carbide Corporation Parma Research Center P. O. Box 6116 Cleveland, OH 44101	(1)
Honeywell, Inc. 104 Rock Road Horsham, PA 19044	(1)	P. R. Mallory & Co., Inc. S. Broadway Tarrytown, N.Y. 10591 ATTN: J. Dalfonso	(1)
Sanders Associates, Inc. Sonobuoy Division 95 Canal Street Nashua, N.H. 03060 ATTN: Mr. David Dwyer	(1)	North American Rockwell Corp. Atomics International Division Box 309 Canoga Park, CA 91304 ATTN: Dr. L. Heredy	(1)
Eagle-Picher Industries, Inc. Electronics Division ATTN: Mr. Robert L. Higgins P. O. Box 47 Joplin, Missouri 64801	(1)	General Electric Research & Development Center P. O. Box 8 Schenectady, N.Y. 12301 ATTN: Dr. Stefan Mitoff	(1)
Yardney Electric Company 82 Mechanic Street Pawcatuck, CT 06379 ATTN: Technical Library	(1)	University of California Department of Science & Research Santa Barbara, CA 93100 ATTN: Dr. J. Kennedy	(1)
Exxon Research and Engineering Co. Corporate Research Laboratory Linden, N.J. 07036 ATTN: Dr. R. Hamlen	(1)	The Electric Storage Battery Co. Carl F. Norburg Research Center 19 W. College Avenue Yardley, PA 19067 ATTN: Dr. A. Salkind	(1)
Argonne National Laboratories 9700 South Cass Argonne, IL 60439 ATTN: Dr. E. C. Gay	(1)	Gulton Industries, Inc. Metuchen, N.J. 08840 ATTN: Mr. S. Charlip	(1)