

AD-A080 976

DEFENCE RESEARCH ESTABLISHMENT OTTAWA (ONTARIO)  
PRELIMINARY RESULTS FROM THE DREO OPTICAL CORRELATION OF SYNTHETIC(U)  
JUN 79 N BROUSSEAU, J W SALT  
DREO-TN-79-12

F/G 17/9

UNCLASSIFIED

NL

| OF |  
AD-  
A080976



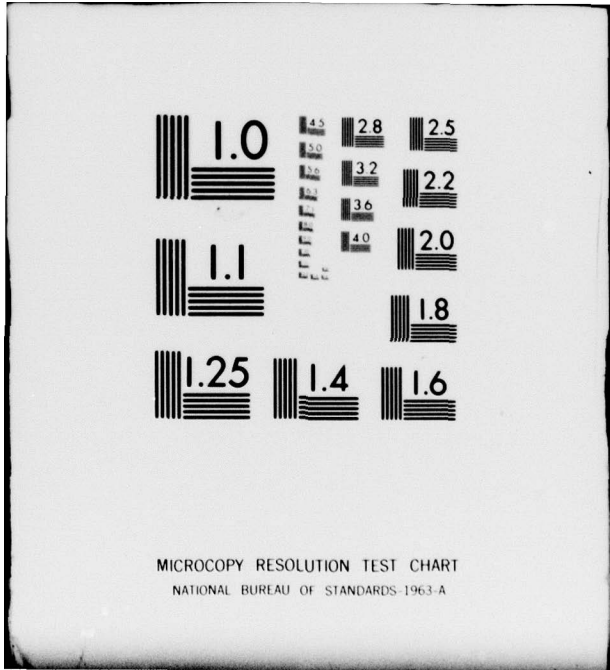

MICROCOPY RESOLUTION TEST CHART  
NATIONAL BUREAU OF STANDARDS-1963-A

RESEARCH AND DEVELOPMENT BRANCH

DEPARTMENT OF NATIONAL DEFENCE  
CANADA

DEFENCE RESEARCH ESTABLISHMENT OTTAWA

9 TECHNICAL NOTE NO. 79-12

14 DREO-TN-79-12

6 PRELIMINARY RESULTS FROM THE DREO OPTICAL CORRELATION OF SYNTHETIC APERTURE RADAR INTERFEROGRAMS.

10 by N/Brousseau and J.W.A./Salt  
Remote Sensing  
Defence Electronic Division

PROJECT NO.  
33D00

Accession For	
NTIS GSA&I	<input checked="" type="checkbox"/>
DDC TAB	<input type="checkbox"/>
Unannounced	<input type="checkbox"/>
Justification	<input type="checkbox"/>
By _____	
Distribution/	
Availability Codes	
Dis	Avail and/or special
A	

11 JUN 1979  
OTTAWA

12 20

404576

bpg

ABSTRACT

*Defense Research Establishment Ottawa*

Some preliminary results are presented from DREO recently acquired optical correlator for synthetic aperture interferograms. The imagery comes from three different sources: The ERIM X and L-band SAR and the modified APS-94D Motorola radar from CRC. Imagery produced at ERIM is compared with imagery produced at DREO from the same interferogram data.

RÉSUMÉ

On présente quelques résultats préliminaires produits par le corrélateur d'interférogramme de radar à antenne synthétique récemment acquis par le CRDO. Il s'agit d'images provenant de 3 radars différents soient le radar d'ERIM bande X et L et le radar Motorola APS-94 modifié par le CRC. On compare les premières images produites à CRDO avec celles produites à ERIM à partir des mêmes données.

TABLE OF CONTENTS

	<u>Page</u>
<u>ABSTRACT/RÉSUMÉ</u> .....	iii
<u>TABLE OF CONTENTS</u> .....	v
<u>1.0 INTRODUCTION</u> .....	1
FIGURE I .....	1
<u>2.0 DESCRIPTION OF THE OPTICAL CORRELATOR</u> .....	2
FIGURE 2 .....	3
FIGURE 3 .....	4
FIGURE 4 .....	4
FIGURE 5 .....	5
TABLE I .....	6
<u>3.0 IMAGERY EVALUATION</u> .....	6
<u>3.1 Imagery from ERIM X-band SAR</u> .....	6
FIGURE 6 .....	7
FIGURE 7 .....	8
FIGURE 8 .....	8
FIGURE 9 .....	9
<u>3.2 Imagery from ERIM L-band Radar</u> .....	9
FIGURE 10 .....	10
FIGURE 11 .....	10
<u>3.3 Imagery from CRC Radar</u> .....	11
FIGURE 12 .....	11
<u>3.4 Discussion of Analysis Technique</u> .....	12
<u>4.0 CONCLUSIONS</u> .....	12
<u>5.0 REFERENCES</u> .....	13

## 1.0 INTRODUCTION

Synthetic Aperture Radar (SAR) is a remote sensing tool of considerable value. It produces, independent of adverse weather conditions, imagery of the terrain below it and can achieve high resolution.

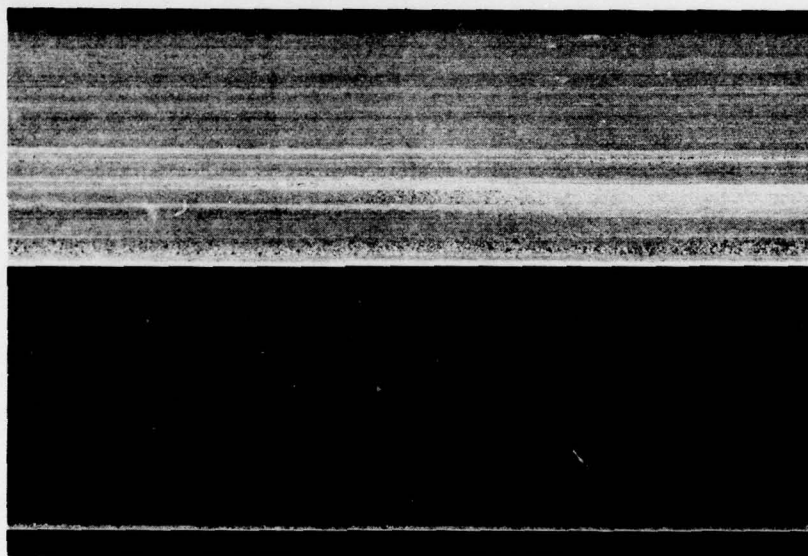

*Figure 1 - Interferogram from a Synthetic Aperture Radar (from ERIM)*

The data produced by this type of sensor is in the form of an interferogram (see Figure 1) which has to be processed to produce imagery suitable for visual interpretation. The additional signal correlation of this data needed to obtain an observable image is fully justified by the great increase in resolution achieved over Sideways Looking Airborne Radar (SLAR).

The Remote Sensing Section at DREO is very interested in the many possible applications of this type of high resolution radar technique.

A project was initiated to investigate, real-time, in flight, processing of SAR interferograms. A program was started in 1973 by Dr. R. Lowry [1] to build an optical correlator compatible with the coherent SAR being developed by the Communications Research Centre (CRC) using an incoherent Motorola APS-94D SLAR.

Initially Mr. Michael Failes [2] of Canadian Instrumentation and Research Ltd., Toronto, was contracted to design a prototype correlator containing separate spherical and cylindrical telescopes. Applied Physics Specialties Ltd., Toronto, manufactured the optical glass elements of the correlator.

The optical correlator was completed in May 1976 and then was assembled by DREO.

The first images were produced using computer generated simulated interferograms [3] since at the time the CRC radar had not produced any interferograms. The results using the simulated data was encouraging so it was decided to proceed with more complex radar interferograms. In conjunction with CRC and the Canadian Centre for Remote Sensing (CCRS), DREO purchased an interferogram and the corresponding correlated imagery from the Environmental Research Institute of Michigan (ERIM). The data resolution, which was degraded to 3 x 3 metres, was obtained from the Marineland Experiment, 1976, over the east coast of Florida, using an X and L Band frequency SAR with cross and parallel polarisation.

At a later date, CRC provided some imagery, obtained from a modified APS 94 radar, of sea ice areas over Northern Canada in the fall of 1976.

Presented herein are the preliminary results of optical processing, using the DREO correlator, of the available interferograms and the results are intended to give some idea of equipment requirements, price, availability and future applications.

The results should not be used for final evaluation of the system. A more complete evaluation will be carried out when the application of techniques mentioned in the Conclusion, Section 4.0, have been examined.

## 2.0 DESCRIPTION OF THE OPTICAL CORRELATOR

Special processing of a radar interferogram is required to obtain observable imagery because of the particular way SAR operates (6) (7). Optical correlation is by far the easiest and least expensive method of producing imagery.

No attempt has been made to explain the SAR system but the concept of the displacement of azimuthal and range focal planes of the interferograms is explained below.

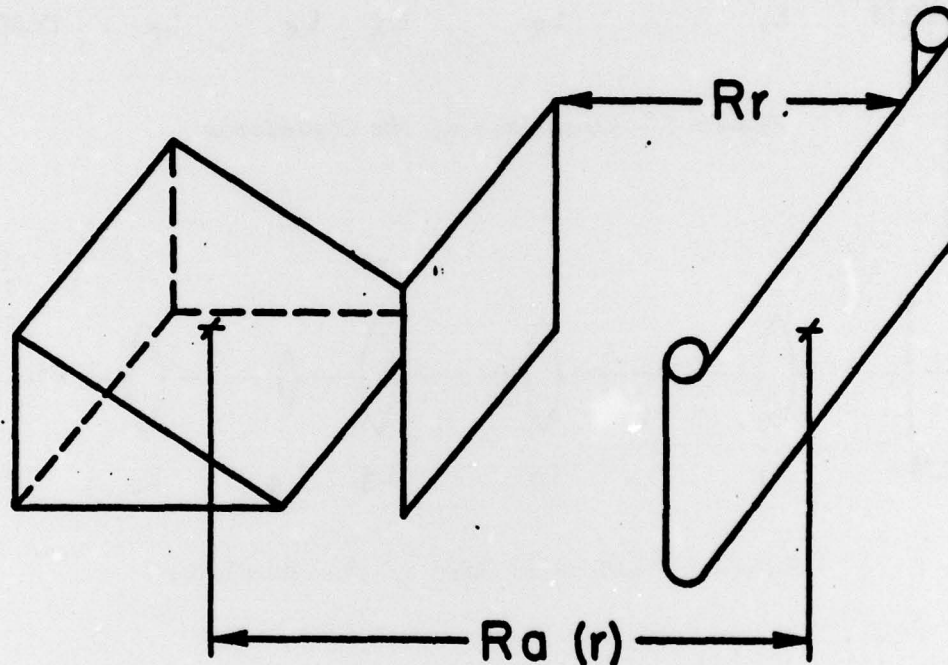

*Figure 2 - Location of Range and Azimuth Information*

The azimuthal signal recorded on the film actually has its image plane focused a specific distance  $R_a(r)$  from the physical film plane. This distance varies with range (see Figure 2). If chirp modulation is used with the SAR system to improve the resolution (as with the ERIM SAR) then the virtual image of the range plane focuses at a distance  $R_r$  from the physical film plane, (see Figure 2), depending on the 'chirp' parameter. With the CRC SAR no chirp modulation was used and the range image is focused at the physical film plane.

To obtain a correlated image, the azimuthal and range planes are focused at an image plane by cylindrical and spherical telescope, lens systems.

The spherical telescope images the range plane information with unity magnification, (see Figure 3). (The cylindrical telescope has no power in the range-plane.)

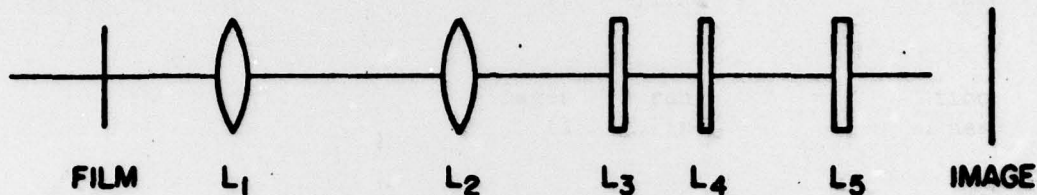

Figure 3 - Range Axis of the Correlator

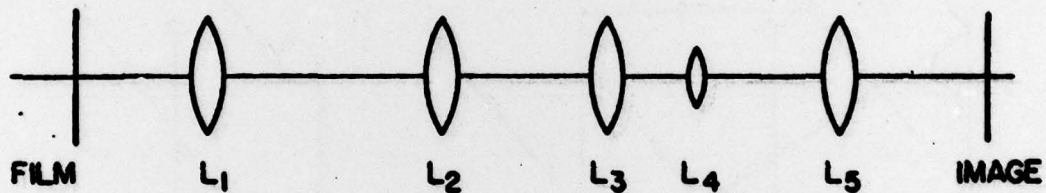
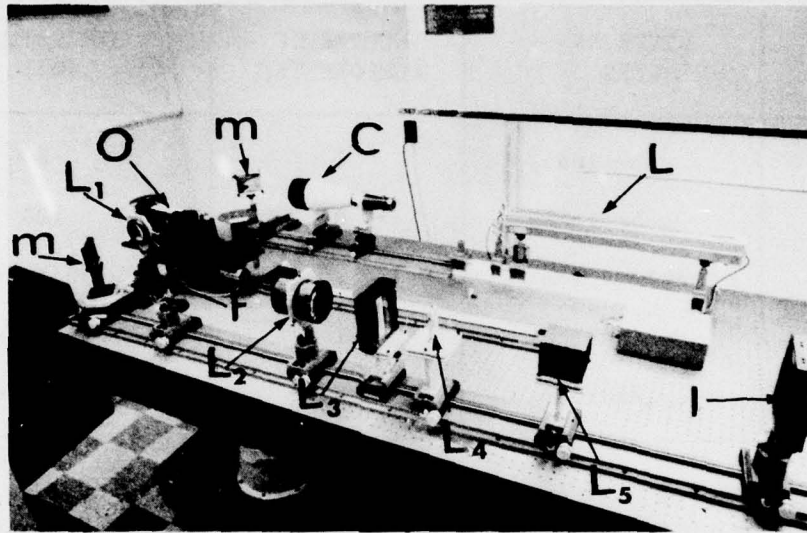

Figure 4 - Azimuthal Axis of the Correlator

The cylindrical telescope applies an appropriate magnification and images the azimuthal information after it has passed through the spherical telescope, (see Figure 4). Note that the final image is produced at the plane, denoted 'Image', in Figures 3 and 4.

The amount of magnification of the cylindrical telescope coincides with the aspect ratio of the interferogram. All interferograms used have 4:1 azimuth to range ratio hence for corrected output at the image plane the magnification of the cylindrical telescope is 0.25.

Figure 5 shows the arrangement of these lens systems used in the DREO correlator.



*Figure 5 - Set up of the DREO Correlator*

L = laser  
 C = collimator  
 M = mirror  
 O = object (interferogram)  
 L<sub>1</sub> = spherical lens  
 F = Fourier plane  
 L<sub>2</sub> = spherical lens  
 L<sub>3</sub> = cylindrical lens  
 L<sub>4</sub> = cylindrical lens  
 L<sub>5</sub> = cylindrical lens  
 I = image

Table I describes the five elements of the correlator. A more detailed description may be found in [2] or [4].

TABLE ICharacteristics of the Five Optical Elements of the Correlator

ELEMENT NUMBER	TYPE OF LENS	NUMBER OF COMPONENTS	DIMENSIONS (mm)
1	spherical	1	80
2	spherical	3	100
3	cylindrical	2	90 x 90
4	cylindrical	1	24 x 80
5	cylindrical	4	70 x 70

The interferogram is placed in a liquid gate at the input plane at a predetermined position relative to element No. 1. When illuminated with a coherent source with a plane wavefront a resulting observable image may be recorded at Plane I, the output, see Figure 5. For convenient observation, a TV camera and monitor may be used to detect the image which allows real time adjustments of the alignment and spacing of lenses.

### 3.0 IMAGERY EVALUATION

#### 3.1 Imagery from ERIM X-band SAR

The preliminary work concentrated on processing ERIM X-band SAR interferograms with the received signal in the same plane of polarization as was transmitted, or 'parallel'. The location of azimuthal and range input were determined using the methods employed by Lee and Greer [5]. It was found that the range information focused in a plane 16 mm from the film plane and the azimuthal information focused in a tilted plane an average of 82 mm from the film plane.

The compression or aspect ratio of the azimuthal information was 4.0 and the resulting maximum resolution obtainable from the imagery was 3 x 3 metres.

The above parameters were used to generate a computer simulation [4] of the correlator to find the optimum location of each of the elements to produce the best image.

Figure 6 shows an image produced by the DREO correlator of ERIM X-band interferogram and can be compared with Figure 7 showing the ERIM correlation of the same interferogram. A brief comparative analysis shows the following observations:

1. The DREO image showed defocusing on both sides of the building also indicating evidence of coma aberration.
2. The resolution of the ERIM image was 1.5 to 2.0 times better than the DREO image, although detail in the building site area was better in the DREO image, possibly due to a better exposure.
3. Speckle size appeared to be proportional to scale but a little more blurred in the DREO case.
4. Contrast was lower in the DREO image giving more information in the lower return areas (water).
5. Ground truth was not available and so no estimates of absolute scale or spatial resolution was made.



*Figure 6 - Image Produced by the DREO Correlator from an X-band Interferogram Bought from ERIM*

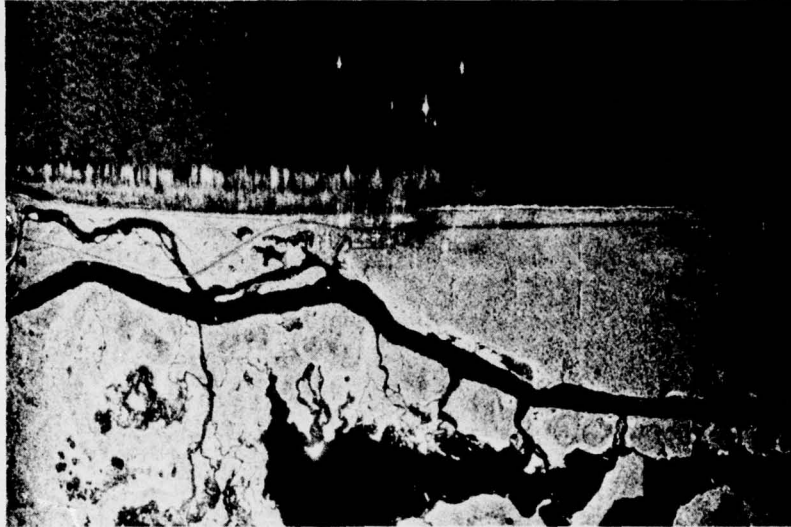
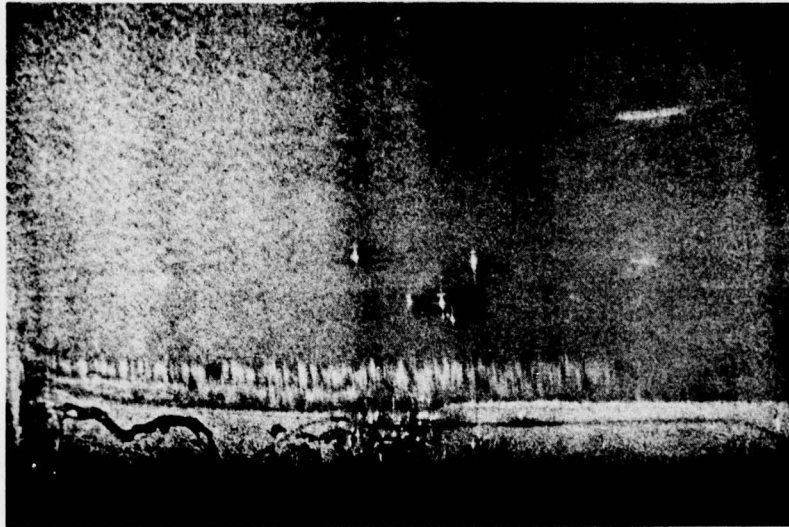

*Figure 7 - Image Produced by the ERIM Correlator from the Interferogram used to Produce the Image Shown in Figure 6.*

Figure 8 shows the DREO ocean image of ships (ERIM X-band SAR), of unknown size, as well as waves. This was produced with the focus on the beach buildings. Figure 9 shows the ocean image of the same area but with defocusing of the buildings by moving the cylindrical telescope 4 mm. Image blurring of the ships and beach building is obvious and expected but the wave images are still sharp although slightly displaced.



*Figure 8 - Sea Waves Picture with Focus on the Beach Building (X-band)*



*Figure 9 - Sea Waves Picture with a 4 mm out of Focus Cylindrical Telescope*

### 3.2 Imagery from ERIM L-band Radar

Correlation of ERIM L-band SAR (parallel polarization) was also achieved with changes to the correlator.

The range input image was focalized at 18 mm from the film plane but it was impossible to measure the location of the azimuthal input image plane because of the distance. Calculations from the parameters gave a location approximately 1 metre from the film plane. The compression ratio was set at 4.5:1.

Figure 10 shows the DREO correlated image of L-band SAR and it can be compared with Figure 11, the ERIM image of same interferogram. The comparison shows that the ERIM imagery is of slightly better quality than that produced by DREO.



*Figure 10 - Image Produced by the DREO Correlator  
from an L-band Interferogram Bought  
from ERIM*



*Figure 11 - Image Produced by the ERIM Correlator  
from the Interferogram used to Produce  
the Image Shown in Figure 10*

### 3.3 Imagery from CRC Radar

The first interferograms from the CRC modified radar were correlated with the imagery shown in Figure 12. The imagery was recorded over an ice field and it was found that the signal recorded had inadequate dynamic range. Further work is being carried out to improve the quality of the interferograms. The generation of the interferogram is slightly different from the ERIM process. The azimuthal input image is focused some 89 mm from the film plane but the range input image is coincident with the film plane. This technique is more noisy as any defect or dust particle on the film will also be imaged. The comparison ratio of the azimuthal image was maintained at 4.0:1

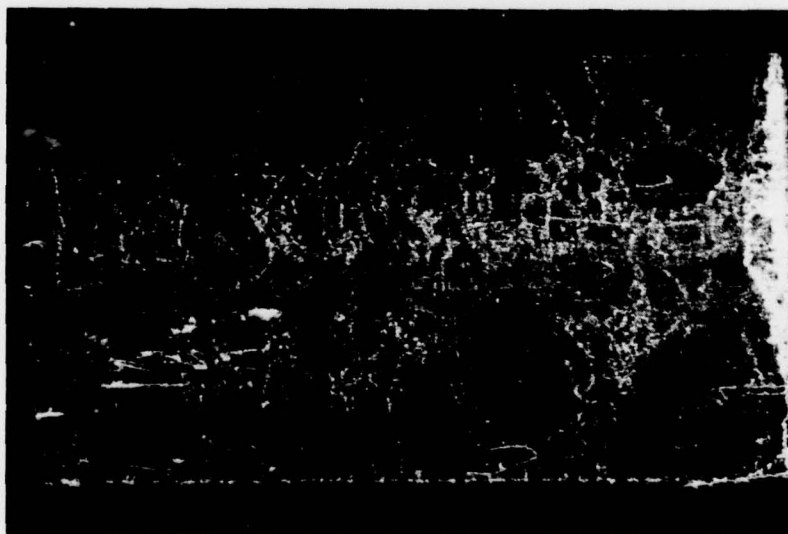

*Figure 12 - Image from an Ice Field Procuded by the DREO correlator from an Interferogram Using the Modified CRC Motorola APS-94*

### 3.4 Discussion of Analysis Technique

1. Difficulties were experienced with the correlation of imagery using tilted input/output planes. Proper tilting mechanism of the films should greatly improve resolution quality.
2. New equipment is being built to improve the mechanical alignment of lenses to help reduce aberrations.
3. Further improvements can be achieved by using standard alignment procedures.
4. Computer design analysis [2] indicated the need for curved azimuthal input and output planes. This aspect has not been investigated yet but could improve the overall quality of the azimuthal image.

### 4.0 CONCLUSIONS

1. The first experiments performed with the correlator were very promising. They demonstrate that the equipment provides a great deal of flexibility in producing imagery from various sources of interferograms, such as, ERIM X-band, ERIM L-band and CRC X-band. The correlation of ERIM L-band SAR, which required considerable alteration to the system, demonstrates the versatility of the design.
2. Even though some of the technical problems related to the use of the correlator have not yet been solved the images produced exceeded expectations.
3. The best quality imagery will be available when the tilted plane and curved plane innovations are incorporated. It is expected that the resulting imagery will equal that produced by the best optical correlators which have been produced to date.

## 5.0 REFERENCES

1. R.T. Lowry. DREO Technical Note No. 74-8. A Feasibility Study for Real Time Optical Correlator for the APS-94D (U).
2. Report on Advanced Optical Design of Radar Correlator, Canadian Instrumentation and Research Ltd., April 1975, D.S.S. Contract No. 2SR4-0123.
3. N. Brousseau. DREO Technical Note No. 76-32. Simulated Interferograms of the Modified APS-94 Motorola Radar.
4. C.J. Brochu et N. Brousseau. DREO Technical Note No. 76-26. Simulation of a Synthetic Aperture Radar Optical Correlator Using a Graphic Terminal.
5. Wai-Hon Lee and Milton O. Greer. Matched Filter Optical Processor. Applied Optics. Vol. 13, No. 4, p. 925.
6. A. Kozma, E.N. Leith and N.G. Massey. Tilted-Plane Optical Processor. Applied Optics. Vol. 11, No. 8, p. 1766.
7. L.J. Cutrona, E.N. Leith, L.J. Porcello, W.E. Vivian. On the Application of Coherent Optical Processing Techniques to Synthetic Aperture Radar. Proc. IEEE, Vol. 54, No. 8, p. 1026. 1966.

**UNCLASSIFIED**

Security Classification

<b>DOCUMENT CONTROL DATA - R &amp; D</b> (Security classification of title, body of abstract and indexing annotation must be entered when the overall document is classified)		
1. ORIGINATING ACTIVITY <b>DEPT. OF NATIONAL DEFENCE, DEFENCE RESEARCH ESTABLISHMENT OTTAWA, OTTAWA, ONTARIO K1A 0Z4</b>		2a. DOCUMENT SECURITY CLASSIFICATION <b>UNCLASSIFIED</b>
		2b. GROUP
3. DOCUMENT TITLE <b>PRELIMINARY RESULTS FROM THE DREO OPTICAL CORRELATOR OF SYNTHETIC APERTURE RADAR INTERFEROGRAMS (U)</b>		
4. DESCRIPTIVE NOTES (Type of report and inclusive dates) <b>TECHNICAL NOTE</b>		
5. AUTHOR(S) (Last name, first name, middle initial) <b>N. BROUSSEAU AND J.W.A. SALT</b>		
6. DOCUMENT DATE <b>JUNE 1979</b>	7a. TOTAL NO. OF PAGES <b>16</b>	7b. NO. OF REFS
8a. PROJECT OR GRANT NO. <b>33D00</b>	9a. ORIGINATOR'S DOCUMENT NUMBER(S) <b>DREO TN 79-12</b>	
8b. CONTRACT NO.	9b. OTHER DOCUMENT NO.(S) (Any other numbers that may be assigned this document)	
10. DISTRIBUTION STATEMENT <b>UNLIMITED</b>		
11. SUPPLEMENTARY NOTES	12. SPONSORING ACTIVITY <b>DAASE</b>	
13. ABSTRACT <b>(UNCLASSIFIED)</b>  <b>Some preliminary results are presented from DREO's recently acquired optical correlator for synthetic aperture interferograms. The imagery comes from three different sources: The ERIM X and L band SAR and the modified APS-94D Motorola radar from CRC. Imagery produced at ERIM is composed with imagery produced at DREO from the same interferogram data.</b>		

KEY WORDS

Synthetic aperture radar  
Coherent radar imagery  
Optical correlation  
Optical processing

INSTRUCTIONS

1. **ORIGINATING ACTIVITY:** Enter the name and address of the organization issuing the document.
- 2a. **DOCUMENT SECURITY CLASSIFICATION:** Enter the overall security classification of the document including special warning terms whenever applicable.
- 2b. **GROUP:** Enter security reclassification group number. The three groups are defined in Appendix 'M' of the DRB Security Regulations.
3. **DOCUMENT TITLE:** Enter the complete document title in all capital letters. Titles in all cases should be unclassified. If a sufficiently descriptive title cannot be selected without classification, show title classification with the usual one-capital-letter abbreviation in parentheses immediately following the title.
4. **DESCRIPTIVE NOTES:** Enter the category of document, e.g. technical report, technical note or technical letter. If appropriate, enter the type of document, e.g. interim, progress, summary, annual or final. Give the inclusive dates when a specific reporting period is covered.
5. **AUTHOR(S):** Enter the name(s) of author(s) as shown on or in the document. Enter last name, first name, middle initial. If military, show rank. The name of the principal author is an absolute minimum requirement.
6. **DOCUMENT DATE:** Enter the date (month, year) of Establishment approval for publication of the document.
- 7a. **TOTAL NUMBER OF PAGES:** The total page count should follow normal pagination procedures, i.e., enter the number of pages containing information.
- 7b. **NUMBER OF REFERENCES:** Enter the total number of references cited in the document.
- 8a. **PROJECT OR GRANT NUMBER:** If appropriate, enter the applicable research and development project or grant number under which the document was written.
- 8b. **CONTRACT NUMBER:** If appropriate, enter the applicable number under which the document was written.
- 9a. **ORIGINATOR'S DOCUMENT NUMBER(S):** Enter the official document number by which the document will be identified and controlled by the originating activity. This number must be unique to this document.
- 9b. **OTHER DOCUMENT NUMBER(S):** If the document has been assigned any other document numbers (either by the originator or by the sponsor), also enter this number(s).
10. **DISTRIBUTION STATEMENT:** Enter any limitations on further dissemination of the document, other than those imposed by security classification, using standard statements such as:
  - (1) "Qualified requesters may obtain copies of this document from their defence documentation center."
  - (2) "Announcement and dissemination of this document is not authorized without prior approval from originating activity."
11. **SUPPLEMENTARY NOTES:** Use for additional explanatory notes.
12. **SPONSORING ACTIVITY:** Enter the name of the departmental project office or laboratory sponsoring the research and development. Include address.
13. **ABSTRACT:** Enter an abstract giving a brief and factual summary of the document, even though it may also appear elsewhere in the body of the document itself. It is highly desirable that the abstract of classified documents be unclassified. Each paragraph of the abstract shall end with an indication of the security classification of the information in the paragraph (unless the document itself is unclassified) represented as (TS), (S), (C), (R), or (U).

The length of the abstract should be limited to 20 single-spaced standard typewritten lines; 7 1/4 inches long.
14. **KEY WORDS:** Key words are technically meaningful terms or short phrases that characterize a document and could be helpful in cataloging the document. Key words should be selected so that no security classification is required. Identifiers, such as equipment model designation, trade name, military project code name, geographic location, may be used as key words but will be followed by an indication of technical context.