

AD-A081 160 BOEING AEROSPACE CO SEATTLE WA BOEING MILITARY AIRPL--ETC F/G 9/2  
EASY-ACIS DYNAMIC ANALYSIS. USER'S MANUAL.(U)  
SEP 79 M K WAHI, G S DULEBA, P R PERKINS F33615-77-C-3054  
UNCLASSIFIED AFFDL-TR-79-3106 NL

1 of 4

AD  
A081160

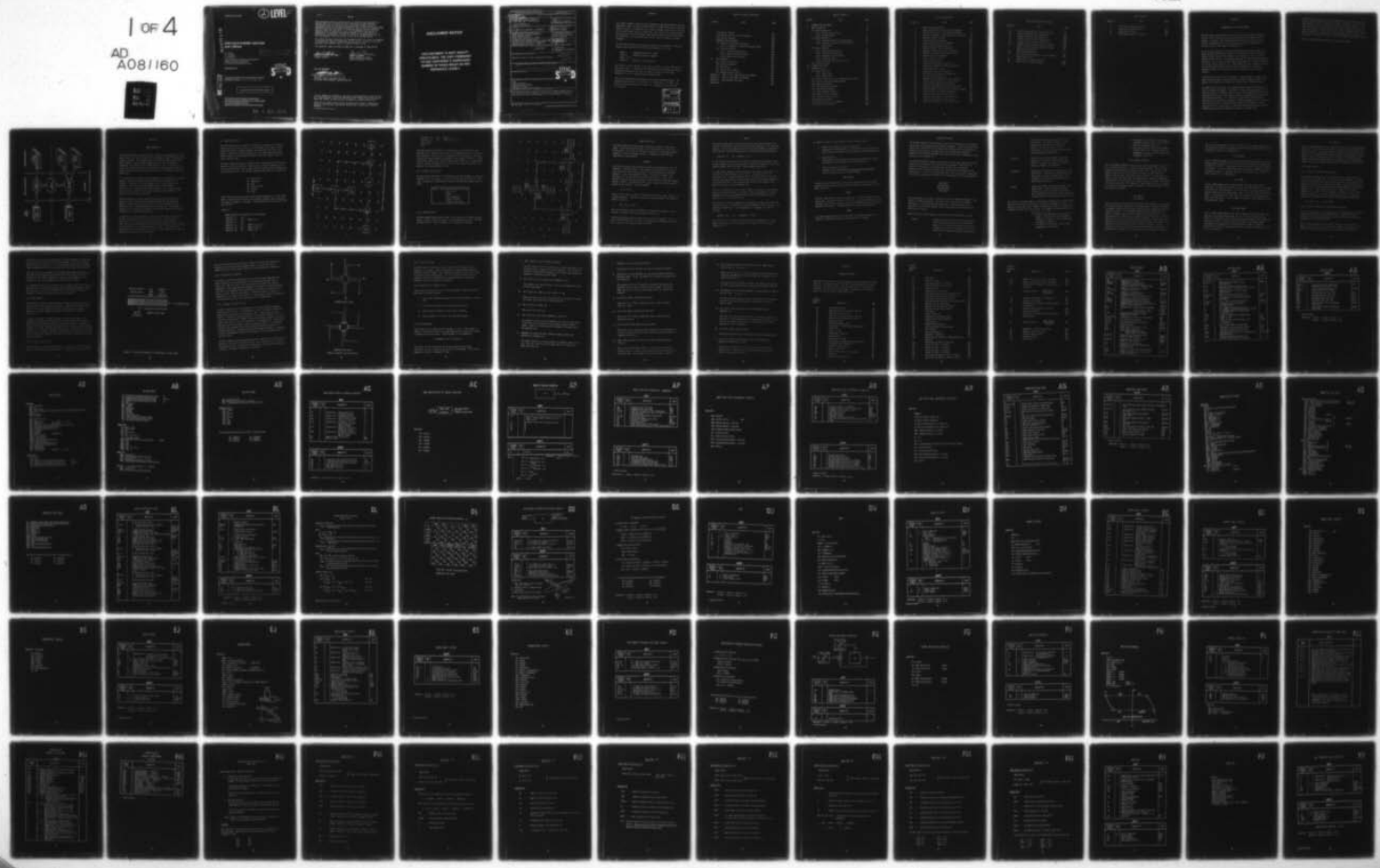

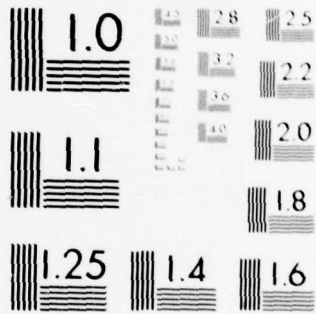

MICROCOPY RESOLUTION TEST CHART  
NATIONAL BUREAU OF STANDARDS 1963-A

AFFDL-TR-79-3106

② LEVEL III

ADA 081160

**EASY-ACLS DYNAMIC ANALYSIS  
User's Manual**

*M. K. WAHI  
G. S. DULEBA  
P. R. PERKINS*

*BOEING MILITARY AIRPLANE DEVELOPMENT  
BOEING AEROSPACE COMPANY  
P. O. BOX 3999, SEATTLE, WA 98124*

SEPTEMBER 1979

THIS DOCUMENT IS BEST QUALITY PRACTICABLE.  
THE COPY FURNISHED TO DDC CONTAINED A  
SIGNIFICANT NUMBER OF PAGES WHICH DO NOT  
REPRODUCE LEGIBLY.

DTIC  
ELECTE  
FEB 28 1980  
S D  
B

DDC FILE COPY

TECHNICAL REPORT AFFDL-TR-79-3106 User's Manual  
Final Report for Period April 1977 to June 1979

Approved for public release; distribution unlimited.

AIR FORCE FLIGHT DYNAMICS LABORATORY  
AIR FORCE WRIGHT AERONAUTICAL LABORATORIES  
AIR FORCE SYSTEMS COMMAND  
WRIGHT-PATTERSON AIR FORCE BASE, OHIO 45433

80 1 22 026

NOTICE

When Government drawings, specifications, or other data are used for any purpose other than in connection with a definitely related Government procurement operation, the United States Government thereby incurs no responsibility nor any obligation whatsoever; and the fact that the government may have formulated, furnished, or in any way supplied the said drawings, specifications, or other data, is not to be regarded by implication or otherwise as in any manner licensing the holder or any other person or corporation, or conveying any rights or permission to manufacture, use, or sell any patented invention that may in any way be related thereto.

This report has been reviewed by the Information Office (OI) and is releasable to the National Technical Information Service (NTIS). At NTIS, it will be available to the general public, including foreign nations.

This technical report has been reviewed and is approved for publication.

  
DAVID L. FISCHER, ILT, USAF  
Project Engineer

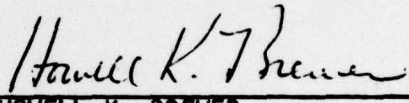
  
HOWELL K. BREWER  
Chief, Mechanical Branch  
Vehicle Equipment Division

FOR THE COMMANDER

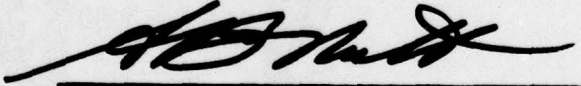
  
A. B. NUTT  
Director, Vehicle Equipment Division  
Air Force Flight Dynamics Laboratories/FEM

"If your address has changed, if you wish to be removed from our mailing list, or if the addressee is no longer employed by your organization please notify AFFDL/FEM, W-PAFB, OH 45433 to help us maintain a current mailing list".

Copies of this report should not be returned unless return is required by security considerations, contractual obligations, or notice on a specific document.

## **DISCLAIMER NOTICE**

**THIS DOCUMENT IS BEST QUALITY  
PRACTICABLE. THE COPY FURNISHED  
TO DDC CONTAINED A SIGNIFICANT  
NUMBER OF PAGES WHICH DO NOT  
REPRODUCE LEGIBLY.**

<b>19 REPORT DOCUMENTATION PAGE</b>		READ INSTRUCTIONS BEFORE COMPLETING FORM	
1. REPORT NUMBER <b>18</b> AFFDL TR-79-3106	2. GOVT ACCESSION NO.	3. RECIPIENT'S CATALOG NUMBER	
4. TITLE (and Subtitle) <b>6</b> EASY-ACLS DYNAMIC ANALYSIS. User's Manual. <span style="float: right;">AD80489</span>		5. TYPE OF REPORT & PERIOD COVERED FINAL APRIL 1977 - JUNE 1979	
7. AUTHOR(s) <b>10</b> M. K. WAHI, G. S. DULEBA, P. R. PERKINS		6. CONTRACT OR GRANT NUMBER(s) <b>15</b> F33615-77-C-3054	
9. PERFORMING ORGANIZATION NAME AND ADDRESS BOEING MILITARY AIRPLANE DEVELOPMENT BOEING AEROSPACE COMPANY P.O. BOX 3999, SEATTLE, WA 98124		10. PROGRAM ELEMENT, PROJECT, TASK AREA & WORK UNIT NUMBERS Project 2402, Task 240201, Work Unit 24020112	
11. CONTROLLING OFFICE NAME AND ADDRESS AIR FORCE FLIGHT DYNAMICS LABORATORY (AFFDL/FEM) AIR FORCE WRIGHT AERONAUTICAL LABORATORIES WRIGHT-PATTERSON AFB, OHIO 45433		12. REPORT DATE <b>1</b> September 1979	
14. MONITORING AGENCY NAME & ADDRESS (if different from Controlling Office) <b>13</b> 292		13. NUMBER OF PAGES 291	
16. DISTRIBUTION STATEMENT (of this Report) Approved for public release; distribution unlimited.		15. SECURITY CLASS. (of this report) UNCLASSIFIED	
17. DISTRIBUTION STATEMENT (of the abstract entered in Block 20, if different from Report) <b>9</b> Final rept 15 Apr 77 - 1 Jun 79		15a. DECLASSIFICATION/DOWNGRADING SCHEDULE	
18. SUPPLEMENTARY NOTES		<b>DTIC ELECTE</b> <b>S FEB 28 1980 D</b> <b>B</b>	
19. KEY WORDS (Continue on reverse side if necessary and identify by block number) EASY Analysis Commands Model Generation Commands Standard Components Air Cushion Landing Systems (ACLS)			
20. ABSTRACT (Continue on reverse side if necessary and identify by block number) This report contains a summary description of the command language used in the EASY dynamic analysis program. In addition, a description of the inputs and outputs for each standard component in the ACLS library is given.			

410258

JUB

## FOREWORD

This report presents results of work conducted by the Boeing Company, Seattle, Washington, under Air Force Contract F33615-77-C-3054 "Application of the EASY Dynamic Program to the Analysis of Air Cushion Systems on Aircraft" during the period from 15 April 1977 to 1 June 1979. This contract was conducted under the sponsorship of the Air Force Flight Dynamics Laboratory, Wright-Patterson Air Force Base, Ohio with Peter Skele and Lt. David L. Fischer as project engineers.

The EASY Model Generation and Analysis programs are documented in three main volumes comprising AFFDL-TR-79-3105 (See Reference 1, 2, 3, 4):

- Volume I - Component Mathematical Models
- Volume II - Component Computer Programs  
(Parts I & II)
- Volume III - Description of Simulations

This report, a User's Manual, was written to provide a concise reference for day to day usage. It summarizes the commands used in the Model and Analysis programs and describes the input and output for each of the standard components in the Air Cushion Landing System Library.

The results presented were developed by the Boeing Aerospace Company. The program managers were A. J. P. Lloyd, H. H. Straub and J. R. Kilner. The principal investigators were M. K. Wahi, G. S. Duleba, J. R. Kilner and P. R. Perkins.

ACCESSION for		
NTIS	White Section	<input checked="" type="checkbox"/>
DDC	Buff Section	<input type="checkbox"/>
UNANNOUNCED		<input type="checkbox"/>
JUSTIFICATION _____		
BY _____		
DISTRIBUTION/AVAILABILITY CODES		
Dist.	AVAIL. and/or	SPECIAL
A	23	DN.

TABLE OF CONTENTS (CONCLUDED)

SECTION	TITLE	PAGE
	4.13 Define Commands	191
	4.14 Optimal Controller Design Commands	192
	4.15 Warning Messages	196
V	AIRCRAFT ANALYSIS EXAMPLE	204
	5.1 Constant Coefficient Aero Models	204
	5.1.1 Six Degree of Freedom Aerodynamic Model	206
	5.2 Trim Calculations	241
	5.2.1 Trim Model Description	251
	5.2.2 Optimal Controller Design	252
	5.2.3 Steady State Solution	254
VI	MISCELLANEOUS	257
	6.1 Program Limitations	257
	6.2 Fortran Statements	258
	6.3 Deck Set-Up	259
	6.4 Tabular Data Example	259
	6.5 Debugging EASY Problems	262
APPENDIX A	INDEX OF EASY MODEL GENERATION COMMANDS	267
APPENDIX B	INDEX OF EASY ANALYSIS COMMANDS	269
APPENDIX C	EASY DOCUMENTATION INDEX	275
REFERENCES		281

## TABLE OF CONTENTS

SECTION	TITLE	PAGE
I	INTRODUCTION AND SUMMARY	1
II	MODEL GENERATION	4
	2.1 Model Description	5
	2.1.1 Phrases and Delimiters	7
	2.1.2 Command Phrases	7
	2.2 Naming Convention	16
	2.2.1 Standard Component Naming Convention	16
	2.2.2 Variable, Parameter, and Table Naming Conventions	16
	2.3 Model Schematic	17
	2.3.1 Standard Schematic Form	17
	2.3.2 Input Quantity Labeling	19
	2.3.3 Component Connection Paths	19
	2.3.4 Additional Pages	21
	2.3.5 Guidelines for Schematic Layout	21
	2.4 Warning Messages	21
III	STANDARD COMPONENTS	25
IV	DYNAMIC ANALYSIS	172
	4.1 Model Input Data	172
	4.1.1 Scalar Data	172
	4.1.2 Tabular Data	173
	4.2 Initial Condition, Error, and Integration Controls	174
	4.3 Initial Condition Storage Commands	175
	4.4 Simulation Commands	176
	4.5 Plot Designation Commands	180
	4.6 Steady State Commands	183
	4.7 Linear Analysis Commands	184
	4.8 Stability Margin Commands	185
	4.9 Transfer Function Commands	186
	4.10 Root Locus Commands	188
	4.11 Eigenvalue Sensitivity Commands	189
	4.12 Function Scan Commands	190

## LIST OF ILLUSTRATIONS

FIGURE NO.	TITLE	PAGE
1	EASY Program Organization	3
2	Analyst's Sketch of Air Cycle Machine Schematic	6
3	Line Printer Drawn Air Cycle Machine Schematic	8
4	Character Assignment in Input/Output or Table Names	18
5	Component Connection Paths	20
6	Jindivik 6DOF Airplane Model	207
7	Jindivik Airplane and Trim Components	208
8	Model Input Data Requirements List	210
9	Subroutine EQMO in Model Generation	211
10	Analysis Program-Input Data and Commands	215
11	Playback of Parametric and Tabular Inputs	217
12	Default Values for Parameters	220
13	Optimal Controller Design	221
14	Linear Analysis Output	222
15	Trim Condition Determined by the O.C.	225
16	Playback of Commands for Plotting and Scan	228
17	Input Table Plot, $C_L$ vs $\alpha$	229
18	Steady Scan Analysis for Down-Wind	230
19	Off Line Plots of Down-Wind Steady Scan	231
20	On Line Plot of Steady Scan	232
21	Playback of Input Commands for Next Analysis	233
22	Jindivik Free Longitudinal Linear Analysis	234
23	Jindivik Free Longitudinal Simulation	235
24	Jindivik Free Longitudinal Time History Plots	236
25	Free Longitudinal Time History On Line Plot Example	237
26	Off Line Plots of Side-Wind Steady Scan	238
27	Jindivik Free Lateral Linear Analysis	239
28	Jindivik Free Lateral Time History Plots	240
29	Jindivik Free Longi-Lat Linear Analysis	242
30	Jindivik Free Longi-Lat Time History Plots	243

LIST OF ILLUSTRATIONS (CONCLUDED)

FIGURE NO.	TITLE	PAGE
31	Jindivik Free Longi-Lat Time History Plots	244
32	Output of Transfer Function Analysis	245
33	Transfer Function Output "BODE" Plot	246
34	Transfer Function Output "NICHOLS" Plot	248
35	Transfer Function Output "NYQUIST" Plot	249
36	Parameter Values at the End of Last Analysis	250
37	SCOPE 3.4 Operating System Deck Set Up Model Generation and Analysis	260
38	ACLS Fan Performance Map	261
39	Data Input Format Example for a Two Dimensional Table, ACLS Fan Map	263
40	Table TOTFT As Interpreted by EASY	264
41	ACLS Fan Map as Plotted by EASY	265

LIST OF TABLES

TABLE NO.	TITLE	PAGE
1	EASY Program Language Delimiters	7
2	Integration Method Selection	177
3	Print Control Values	178
4	EASY Model Generation Limitations	257

## SECTION I

### INTRODUCTION TO THE EASY PROGRAM

The EASY program was developed under Air Force Contract F33615-74-C-3041 to provide a means of modeling and analyzing aircraft environmental control systems. In August, 1976, Boeing Computer Services was awarded a second contract, F33615-76-C-3165, to extend the application of the program to include aircraft flight dynamics (Reference 1).

In April, 1977, Boeing Military Airplane Development Division (BMAD) of the Boeing Aerospace Company was awarded a third contract, F33615-77-C-3054, to extend the application of the program to the analysis of the Air Cushion Landing Systems (ACLS). This document describes the use of the EASY program (Section I, II, IV) and the input/output requirements for standard components in the ACLS library (Section III). The document provides an abridged version of the EASY program users guide contained in Reference (2). Section V presents examples of the application of the program to aircraft dynamic analysis.

The EASY program consists of two programs, a model generation program and a model analysis program, which allow a wide variety of dynamic systems to be modeled and analyzed as to either their steady state or dynamic behavior.

The modeling of most systems can be accomplished by describing the system in terms of standard components. The models of these standard components have been constructed in a general fashion so that with the proper choice of input parameters and tables, a wide range of specific components can be modeled by each standard component. If a portion of a particular system cannot be described using the standard components, FORTRAN statements can be included in the model description to describe these portions of the system. Given a description of the system model, the EASY Model Generation program generates FORTRAN subroutines which represent that model in program form.

This computerized model can then be analyzed by any of the nonlinear, linear, dynamic, or steady state techniques available in the EASY Analysis program. These analyses include: nonlinear simulation; steady state analysis; linear model generation from the original nonlinear model; eigenvalue calculation; root locus analysis; transfer function calculation; and several other dynamic analysis techniques. In addition to these analyses, optimal controllers of the optimal linear regulator type can also be designed by the Analysis Program.

Figure 1 shows the general organization of the EASY program.

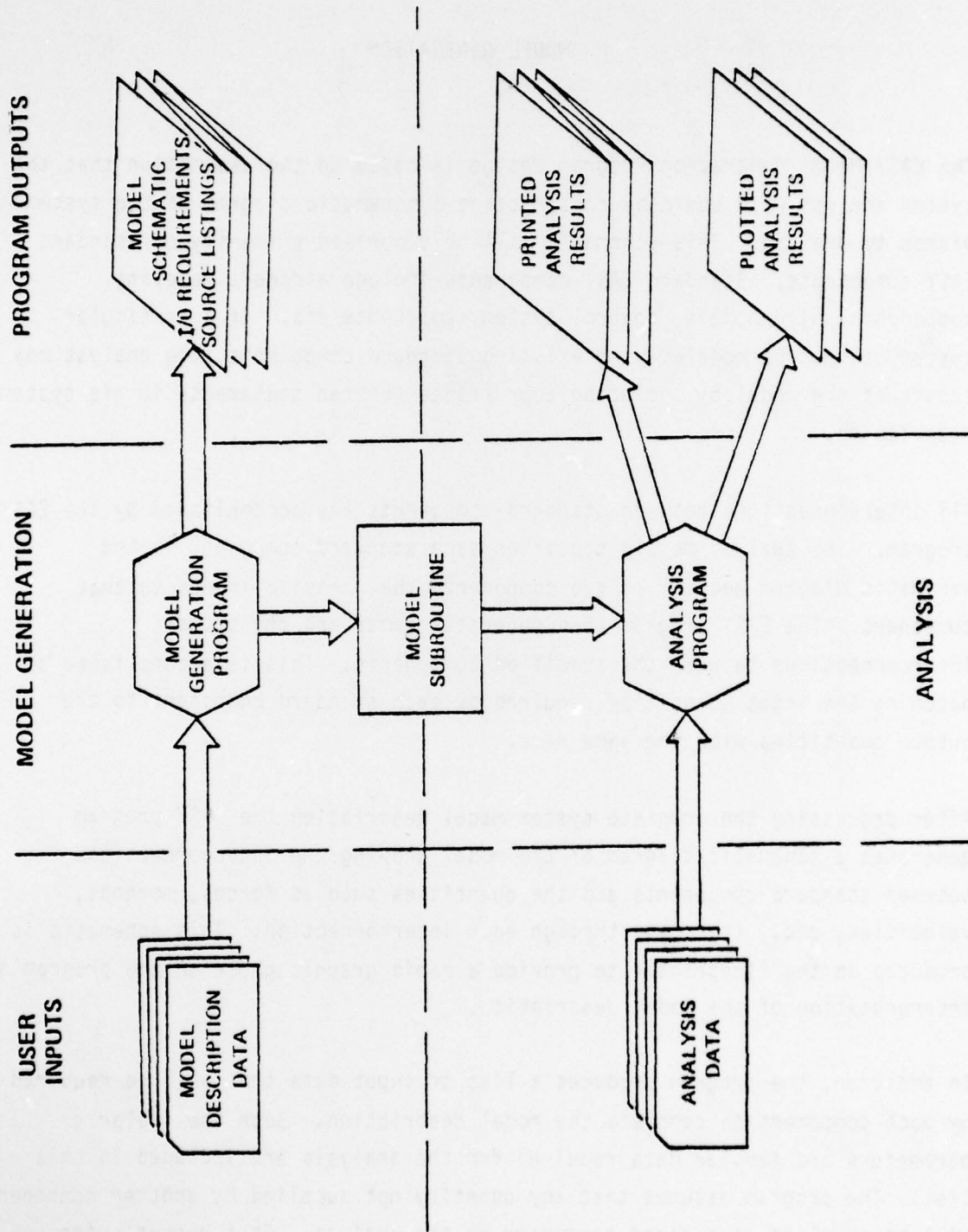

Figure 1 EASY Program Organization

## SECTION II

### MODEL GENERATION

The EASY Model Generation Program design is based on the assumption that the system analyst will begin by constructing a schematic diagram of the system he wishes to analyze. This schematic will be comprised primarily of standard EASY components. Standard EASY components include aircraft modeling components, wind models, control system components etc. If a particular system can not be modeled with existing standard components, the analyst may construct the model by including appropriate Fortran statements in his system description.

All interconnections between standard components are accomplished by the EASY program. The analyst merely specifies each standard component in the schematic diagram and all of the components that provide inputs to that component. The EASY program then generates names and the proper interconnections between the specified components. This is accomplished by matching the input quantities required by each standard component to the output quantities with the same name.

After processing the complete system model description the EASY program generates a schematic diagram of the model showing the interconnections between standard components and the quantities such as forces, moments, velocities, etc., that pass through each interconnection. This schematic is produced on the lineprinter to provide a rapid graphic check on the program's interpretation of the model description.

In addition, the program produces a list of input data that will be required by each component to complete the model description. Both the scalar parameters and tabular data required for the analysis are included in this list. The program assumes that any quantity not supplied by another component will be supplied as a fixed parameter by the analyst. Thus requests for nonparameter items in the input data list will reveal any connection that was omitted from the system model description.

## 2.1 Model Description

The EASY Model Generation program is a precompiler program which processes model description instructions into a Fortran model of the system. These instructions contain "program commands" which are made up of one or more words. In addition to program commands, an EASY system model description contains numeric values, standard component names, and standard input and output quantity names.

The EASY commands may be best introduced with a simple example of their use to describe an air cycle machine. Figure 2 shows an analyst's schematic of an air cycle machine model that has been constructed using standard components on an EASY schematic form. The standard component names used in this sample are:

IO - Source of Air  
CO - Compressor  
DE - Duct  
HA - Heat Exchanger  
TU - Turbine  
SH - Shaft

Since there may be more than one of each standard component in a given system model, a number may be attached in each standard component name to designate the specific component in the model. The EASY description of this model would be as follows:

### Example 2.1

```
MODEL DESCRIPTION = BOOTSTRAP AIR CYCLE MACHINE
LOCATION = 61      IO 1
LOCATION = 63      CO 1      INPUTS = IO 1
LOCATION = 5       IO 2
LOCATION = 25      HA       INPUTS = CO 1, IO 2
LOCATION = 45      DE 1      INPUTS = HA(4,1)
LOCATION = 68      TU 1      INPUTS = HA
```

EASY SCHEMATIC FORM

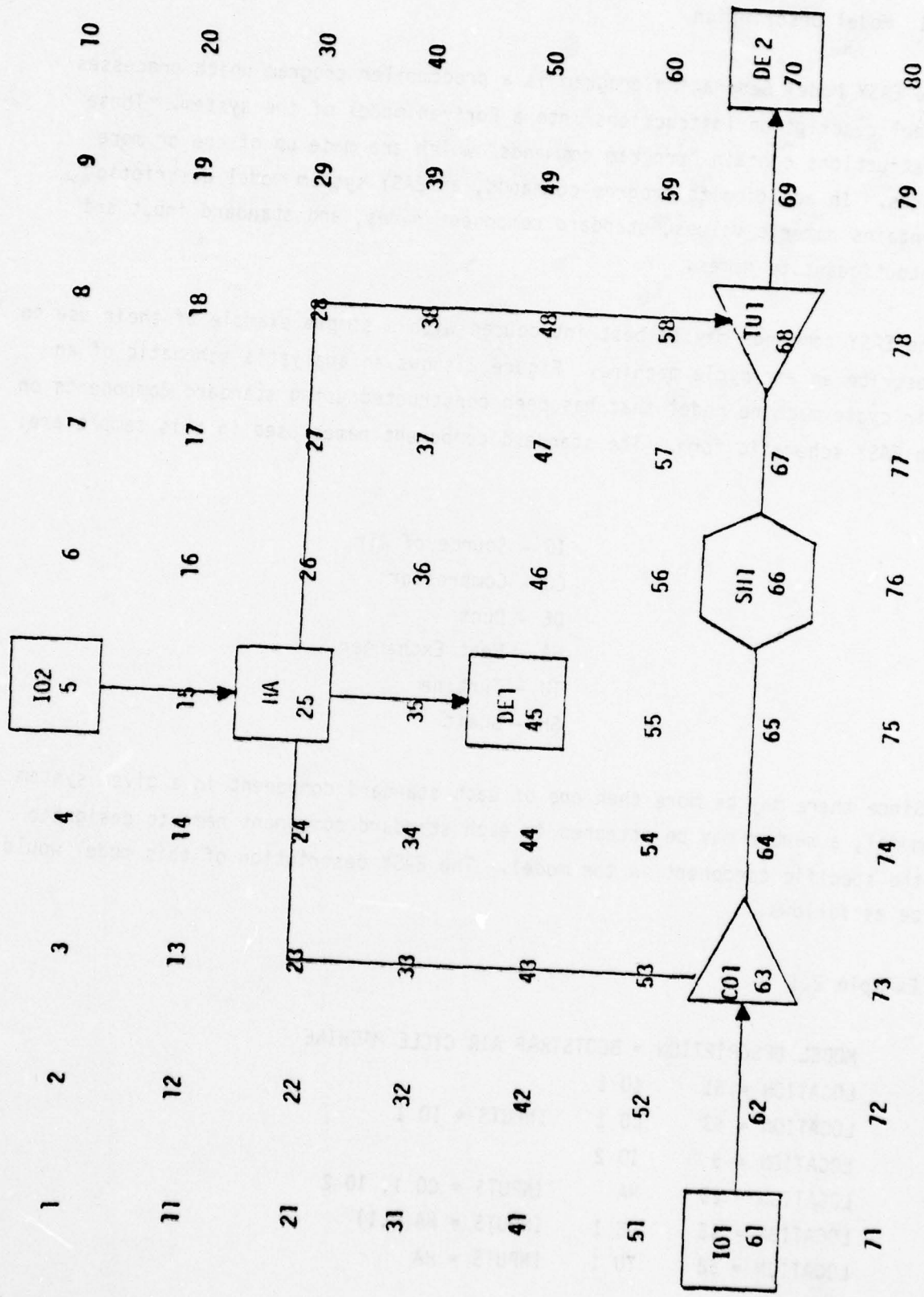

Figure 2 Analyst's Sketch of Air Cycle Machine Schematic

```
LOCATION = 70    DE 2    INPUTS = TU 1
LOCATION = 66    SH 1    INPUTS = CO 1, TU 1
END OF MODEL
PRINT
```

The model description consists of a statement as to the location of each component in the schematic and a list of all components that provide inputs to that component. The location of the component in the schematic is used for a line printer drawn schematic of the model, such as shown in Figure 3. In the line printer schematic the input and output quantities such as: temperatures (T2 CO 1, T3 HA); pressures (P1 TU 2, P1 CO 1); and shaft rpm (EN SH 1) are shown on the various connecting lines.

### 2.1.1 Phrases and Delimiters

The system model description is interpreted by the EASY program as a series of "phrases", which can appear in a free field format in any position on a data card. Phrases must be separated by any one of the delimiter symbols shown in Table 1.

TABLE 1 EASY PROGRAM LANGUAGE DELIMITERS

= equal sign
, comma
( left parenthesis
) right parenthesis
three or more blanks

### 2.1.2 Command Phrases

The EASY command phrases are described in this section in a logical sequence similar to that in which they appear in system model descriptions. For easy reference they are listed in Appendix A, in alphabetical sequence.

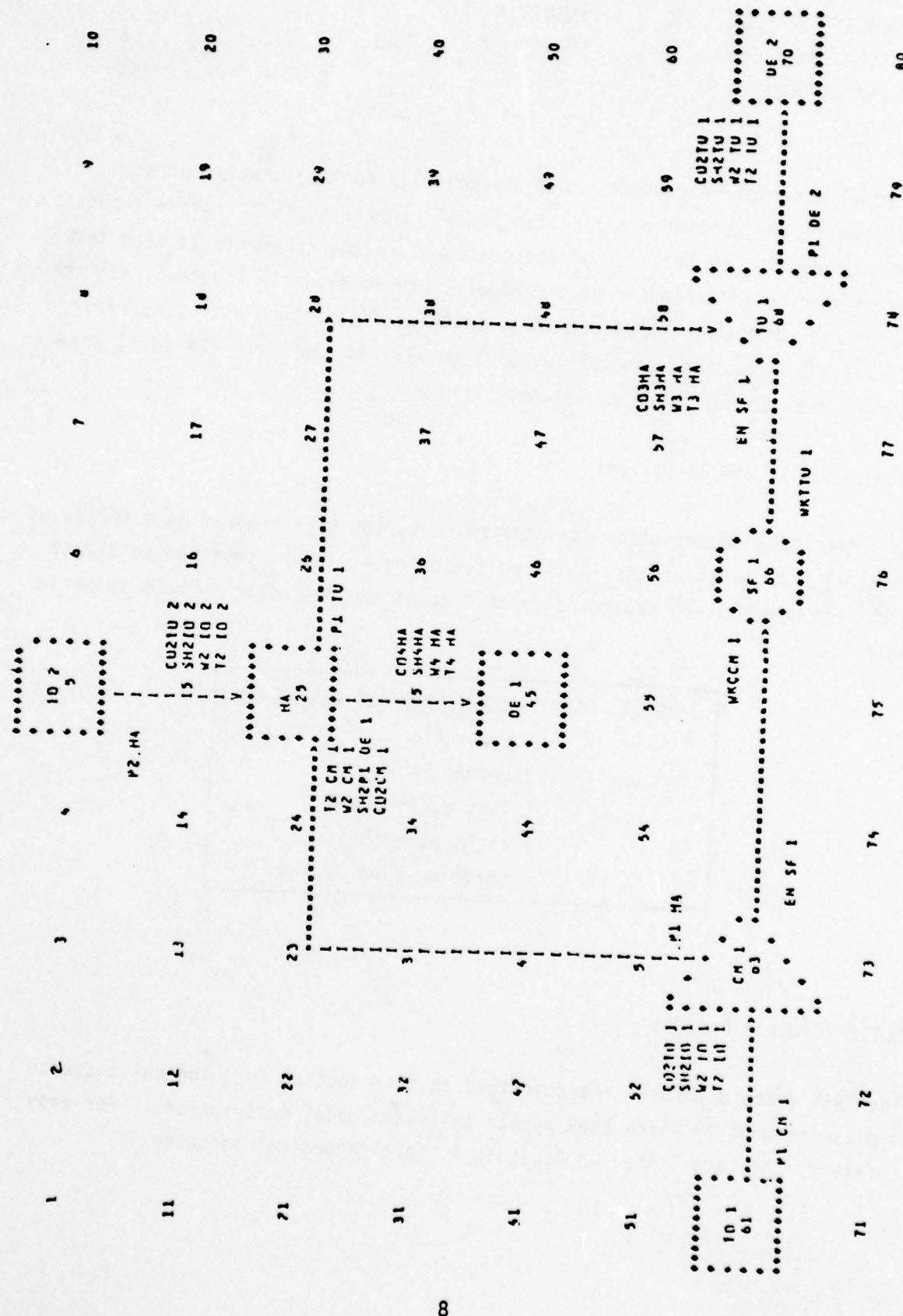

Figure 3 Line Printer Drawn Air Cycle Machine Schematic

## MODEL DESCRIPTION

The MODEL DESCRIPTION command phrase indicates the start of a new system model. This phrase may be followed, (on the same card), by a title of up to 60 characters. This title will be used to identify various program output schematics, lists and program listings. In Example 2.1, the title was "Bootstrap Air Cycle Machine."

## LOCATION

The LOCATION command phrase indicates the start of the description of a new component in the system model. This command must be followed by a numeric value phrase that specifies the location of the new component on the model schematic. Thus in the example of Figure 2, the location number of the compressor CO 1 was 63 and the turbine TU 1 was 59, etc. To be a valid component location, the last two digits of this number must comprise a number between 1 and 80. The hundreds column is used to specify additional pages as needed for the schematic. Thus the numbers:

1, 12, 51, 80

would be valid location numbers for components on the first page, (PAGE 0), of a system schematic. These same locations on the second page of the schematic, (PAGE 1), would be:

101, 112, 151, 180

The location number phrase is followed by the name of the component at that location. Component names are discussed in Section 2.2.

A LOCATION statement should be given only once for each component. That is, once a LOCATION statement is started for a component the complete description of all inputs to that component should be given.

## INPUTS

The INPUTS command phrase indicates that the following phrases contain the names of the components that provide inputs to the component at the specified location. Thus in the example of Figure 2, the heat exchanger at location 25 which receives inputs from compressor CO 1 and source IO 2 was described as:

```
LOCATION = 25    HA    INPUTS=CO 1, IO 2
```

In this example the command phrase INPUTS is followed by two component names. As many component names as are necessary to specify the inputs to a particular system component may be included in each component description.

For some system components there are multiple input and/or output ports. As an example, a heat exchanger has four ports: (1) hot-side inlet, (2) cold-side inlet, (3) hot-side outlet, and (4) cold-side outlet. Since most aircraft modeling components have only two ports, the use of port numbers will not be described here. For a complete description of this aspect of the program see Section 3.3.2 of Reference (2).

For certain components, such as control elements, the inputs to the component can be any physical quantity in the model. For these components, the input component names must be supplemented by the name of the particular output quantity that is to provide the input.

As an example, consider a component that represents a linear first order lag transfer function. If the transfer function component's input, FIN, was to be the output temperature, T, of a compressor CO 1 in example 2.1, then a statement:

```
LOCATION = 51    LA 1    INPUTS=CO 1 (T:FIN)
```

would indicate to the program that of the outputs of compressor CO 1, the output temperature, T, was to be used as the input, FIN, to the transfer function, LA 1.

To summarize, there are three levels of connection specification:

1. Default (only component names are specified)  
Connections are made between all *unconnected* inputs and outputs for the first ports for which a match of physical quantity names occurs.
2. Ports Specified  
Connections are made between matching physical quantities for all unconnected inputs and outputs of the specified ports.
3. Physical Quantities Specified  
Connections are made between only those quantities specified.  
Previous connections can not be over-ridden.

#### END OF MODEL

The END OF MODEL command phrase indicates that model description has been completed and that the EASY program should proceed with the generation of the model subroutines.

#### PRINT

The PRINT command phrase causes the program to: (1) draw a schematic of the system model, as shown in Figure 2; (2) print a list of input requirements for the model; and (3) print a source listing of the FORTRAN subroutines that were generated for the model. The Model Generation program then terminates.

#### PUNCH

The PUNCH command phrase has the same effect as the PRINT command, but in addition a FORTRAN source deck of the system model is produced.

## FORTRAN STATEMENTS

The FORTRAN STATEMENTS command phrase allows the system analyst to supplement the standard EASY components with FORTRAN statements. Using this feature, the analyst can introduce his own program logic, DO loops, etc., as necessary to model any system feature not obtainable with standard EASY components. Examples of the FORTRAN STATEMENTS are given in Section 5.2, Reference (1) and Section 3.2.2, Reference (2).

The FORTRAN STATEMENTS command would normally be used when some portion of the system cannot be modeled with standard EASY components. When using this feature of the program, the analyst must perform many of the detail connections and naming of variables, that are normally accomplished by the EASY program. In return for these added tasks, the analyst gains a great deal of additional freedom and flexibility in forming details of this system model.

ADD STATES  
ADD VARIABLES  
ADD PARAMETERS  
ADD TABLES

The ADD commands may be used in conjunction with the FORTRAN STATEMENTS to add states, variables, parameters, and tables that occur within the FORTRAN statements, to the EASY generated system model. Quantities that are not specified by one of these commands cannot be accessed or manipulated by the EASY Analysis Program.

Before discussing these commands, a few definitions of terms are in order.

States: States are those quantities in the system model that are described by first order differential equations. The state variables are the result of integrating the set of first order differential equations that comprise the dynamic system model.

The number of states equals the order of the system model. The states are dynamic, time varying quantities during most simulation studies. The initial values, (initial conditions), of the states must be input as part of the system model description.

**Variables:** Variables are all other dynamic time varying quantities in the system model that are not states. In general, variables are related to states by algebraic relationships.

**Parameters:** Parameters are constant scalar quantities in the system model. Parameters can be manipulated by the analyst to alter the system model. All parameter values should be input as part of the system model description.

**Tables:** Tables are constant nonscalar quantities in the system model. Tables are used to represent algebraic functional relationships with one or two independent variables. All table values must be input as part of the system model description.

The format for the ADD commands is the command followed by one or more phrases that contain the names of the states, variables, parameters, or tables. In addition to each table name, a number, specifying the amount of storage to be allocated for that table must be given. This number is given by the formula:

$$N = \pm (3 + I + J + D)$$

N = the total storage required by the table, in words. If the table has one independent variable N is negative, for two independent variables N is positive.

I = the number of data points in the primary independent variable table.

J = the number of data points in the secondary independent variable table. (J=0 if there is only one independent variable.)

D = the number of data points in the dependent variable table. (D=I if there is only one independent variable. D=I\*J if there are two independent variables.)

#### LIST STANDARD COMPONENTS

The LIST STANDARD COMPONENTS command phrase causes the program to print a list of all standard components. For each standard component, lists of inputs, outputs, and tables for that component are provided. For each input, the physical quantity name and port number is given. For each output, the physical quantity name, port number, and the letter S, if the quantity is a state is given. For each table, the table name, the number of independent variables and the maximum amount of storage allowed is provided. This command is usually given as the first command of a model description and will result in a list of all standard component information as the first output from the Model Generation Program.

#### O.C. INPUTS

#### O.C. OUTPUTS

The O.C. INPUTS and other commands starting with the letters "O.C." are used to include an optimal controller in the system model. An optimal controller is a general purpose control component which can have an arbitrary number of inputs and outputs. It is therefore necessary for the system analyst to specify the identity of each optimal controller input and output. This is done using the O.C. INPUTS and O.C. OUTPUTS commands rather than the INPUTS command that is used for the other standard components. Optimal controller inputs are output quantities, either variables or states, from standard model components which are sensed in order to control the system. Optimal controller outputs are input quantities, either variables or parameters, to standard model components that are actuated in order to control the system.

The use of these commands is shown in Section 5.3. A complete description of the calculation methods and theoretical basis for the optimal controller are presented in Section 4.4 of Reference 2.

#### O.C. CRITERIA

The O.C. CRITERIA command is used to specify those output quantities from the standard model components that are to be used as the criteria for designing the optimal controller. These quantities are specified in the same format as O.C. INPUTS. If no O.C. CRITERIA are specified, the O.C. INPUTS are used as the design criteria. A complete discussion of the use of O.C. CRITERIA is given in Section 3.3 of Reference 2.

#### O.C. ORDER

The O.C. ORDER command can be used to specify the order of the optimal controller. If the optimal controller order is not specified it will be taken as the order of the system model. This will result in a total system order, (optimal controller plus system model), that is twice the order of the system model. In most cases such a high order optimal controller is unnecessarily complex and impractical. The O.C. ORDER is limited to values between zero and the system model order.

#### O.C. MODEL ORDER

The O.C. MODEL ORDER command can be used to specify that a model order less than that of the given system model, be used for the optimal controller design. This command is used when optimal controllers are to be designed for high order systems. By using a lower order model, the computer memory requirements and computation time can be greatly reduced. A complete discussion of the use of reduced model orders is given in Section 4.5.10 and 4.5.11 in Reference 2.

## O.C. ANALYSIS

The O.C. ANALYSIS command is used to specify that computer memory requirements provided in the system model need only be large enough for the analysis of an optimal controller. The memory required to analyze a system with an optimal controller is considerably less than that required to do an optimal controller design. Thus if the purpose of a run is to analyze the performance of an optimal controller which was designed on a previous run, the O.C. ANALYSIS command can be used to reduce computing costs and improve the run flow time.

### 2.2 Naming Convention

#### 2.2.1 Standard Component Naming Convention

All standard components are given names consisting of two characters, the first of which is alphabetical. Thus we have CO for compressor, TU turbine, HA for heat exchanger, etc. Where multiple components of the same type are required, two additional characters can be added to the end of the standard component name to distinguish between the different models of the same basic component type. These characters are usually numeric but can also be alphabetical or blanks. Thus a given model can contain up to  $37^2 = 1369$  different components of the same standard component type. For example, a model with ten different ducts might have these components designated as:

DE 1, DE 2, DE 3 ....., DE 9, DE10

#### 2.2.2 Variable, Parameter, and Table Naming Conventions

All of the input, output, and tabular quantities required by each component in a system model must have unique FORTRAN names. These FORTRAN names are composed of a standard component name prefixed by a physical quantity name consisting of up to three characters.

Since a single component may have several inputs or outputs of the same physical quantity, the program adds the port number to the second or third character of the physical quantity name to prevent such a duplication.

The physical quantities that are outputs of a given component are identified by adding the four character name of that component to the three character name of the physical quantity. In this way, unique seven character FORTRAN names are generated for all output quantities of the system model components.

Input quantities to a component that are generated by another component carry the names of the component that generates them. Any inputs that are not satisfied by other model components are assumed to be parameters and are assigned the name of the component for which they are an input.

If a component should require tabular data as an input, unique table names are generated just as scalar input quantity names by adding the component name to the table name. A pictorial representation of the character assignment in component, variable, and table names is given in Figure 4.

### 2.3 Model Schematic

The EASY Model Generation program produces a schematic diagram of the system being modeled. This schematic is crude but is inexpensive and does not have the flow time delays associated with more elaborate plotting methods. Its purpose is to provide a means of rapidly locating errors in the model description.

In order to construct a schematic diagram in an efficient manner with a reasonable size program it was necessary to establish some simple rules for symbol generation, component connection paths, and labeling. If these rules are kept in mind when laying-out a schematic for the system, the EASY produced schematic will match that developed by the analyst. If the rules are violated by the analyst's schematic, the EASY schematic should still be correct but may contain some unusual component connection paths and some labeling information may be overwritten.

#### 2.3.1 Standard Schematic Form

The EASY schematic diagrams are produced on a standard 11" by 14" lineprinter page with 80 component locations per page. A standard form containing only

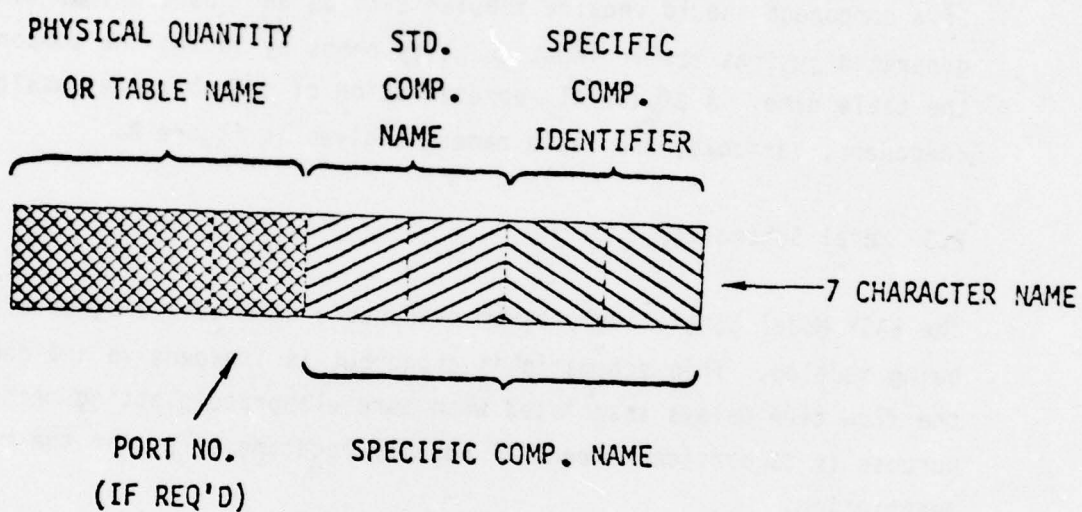

Figure 4 Character Assignment in Input/Output or Table Names

the location numbers can be obtained by executing the EASY model Generation program with the single program command, PRINT. This form can then be reproduced and the copies used as forms for drawing system model schematics.

### 2.3.2 Input Quantity Labeling

The names of the physical quantities that are input to each component from other components are listed adjacent to the downstream component symbol. These input names are placed near the connecting line that joins the two components. Since these names are composed of the physical quantity name and the name of the component that generates the information, the source of the input is evident from the name itself. Parameter and tabular inputs to a component are not shown on the schematic. These constant inputs are described in the Input Requirements List, (See Section 3.5 of Reference 2).

### 2.3.3 Component Connection Paths

In order to keep the core requirements and run time of the EASY schematic drawing subroutine small, it was necessary to limit the types of connecting paths between components to a few basic routes. These paths are shown in Figure 5. Connections between components on the same horizontal or vertical line are straightforward. However, connections between components that do not share a horizontal or vertical line require a two segment path. These paths have been arbitrarily chosen to follow a clockwise route. It is therefore advisable that components that are on diagonal locations be placed in a clockwise sequence. If counterclockwise flow between components is necessary it can be accommodated by placing the components on the same horizontal or vertical lines.

The EASY schematic drawing subroutine makes no attempt to go around components that get in the way of a connection path. Such components are "run-over" by the connecting line. Section 3.4 of Reference 2 contains several examples of connection "problems" and methods to avoid them.

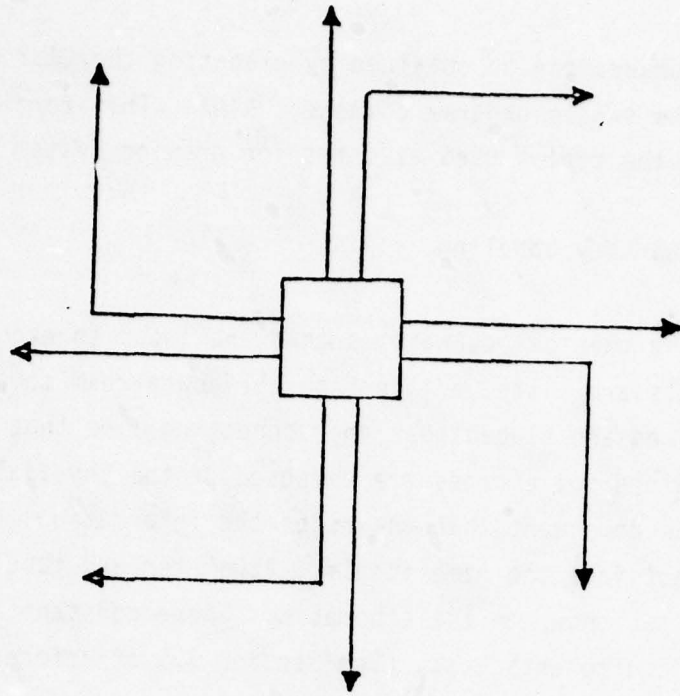

POSSIBLE OUTPUT PATHS

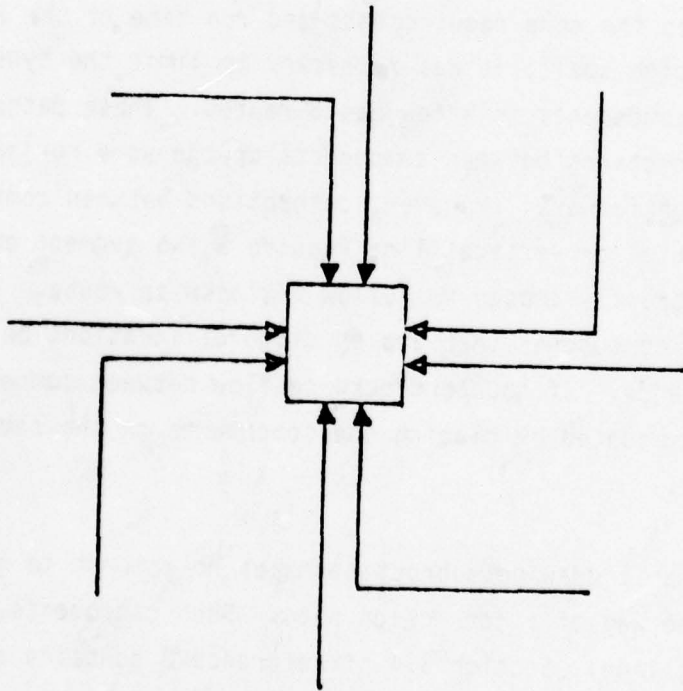

POSSIBLE INPUT PATHS

Figure 5 Component Connection Paths

#### 2.3.4 Additional Pages

The EASY schematic diagram may be broken down into as many pages as are necessary. No attempt is made to draw connecting paths between components located on different pages. It is therefore advisable to minimize the number of connecting paths between pages. This can usually be done by grouping components with many interconnections on the same page and placing page boundaries between such groups of components.

#### 2.3.5 Guidelines for Schematic Layout

The following guidelines may help in creating schematic layouts that can be duplicated by the EASY program.

1. Try to place connected components on the same horizontal or vertical line.
2. Avoid placing components on adjacent location points.
3. Place diagonal components so that flow is clockwise.
4. Group components to minimize flow paths between pages.

#### 2.4 Warning Messages

One or more of the following warning messages will occur if the program is unable to interpret a portion of the model description or encounters problems in assembling the system model. These messages will be preceded by:

\*\*\* WARNING \*\*\* or \*\*\* NOTICE \*\*\*

The symbols xxx and zzz are used to indicate phrases from the model description that are included as part of the warning message. The following messages are listed in alphabetical order:

1. CAN'T IDENTIFY xxx AS A STANDARD COMPONENT

xxx will contain the first two characters of the phrase which cannot be identified as a command or standard component. This message will often follow other warning messages as the program makes successive attempts to interpret the given phrase.

2. CAN'T IDENTIFY xxx AS A VALID INPUT COMPONENT TO zzz

The component xxx cannot be found in the list of components for the current system model.

3. CAN'T LOCATE O.C. INPUT, xxx, WILL RENAME AS: zzz

Check spelling of name xxx or that the quantity xxx has been renamed as a result of being driven by another component.

4. CAN'T LOCATE O.C. OUTPUT, xxx

Check spelling of name xxx.

5. CAN'T LOCATE xxx AS AN INPUT COMPONENT TO LOCATION n

This message indicates that the component xxx, which provides inputs to location n in the schematic, has not been assigned a location number. Check for a missing LOCATION statement or mis-spelling of the component name.

6. COMPONENT xxx DEFINITION WASN'T COMPLETED BEFORE STARTING THE DEFINITION OF COMPONENT zzz

The command INPUTS was not given between the component names xxx and zzz. Check for proper spelling of INPUTS and a valid delimiter after the phrase xxx.

7. COMPONENT xxx HAS ALREADY BEEN DEFINED

The component xxx was defined in a previous LOCATION statement.

8. LOCATION NO. xxx FOR COMPONENT zzz HAS LAST TWO DIGITS OUTSIDE THE ALLOWABLE RANGE 1 TO 80. NO SYMBOL WILL BE PLACED IN SCHEMATIC FOR THIS COMPONENT

This message will occur at the end of the model description for a component zzz which has an invalid location number. The system model may still be valid but the schematic will not contain this component.

9. NO OPTIMAL CONTROL INPUTS WERE SPECIFIED

Check that "O.C. INPUTS" command was used to specify optimal controller inputs.

10. NO OPTIMAL CONTROL OUTPUTS WERE SPECIFIED

Check that "O.C. OUTPUT" command was used to specify optimal controller outputs.

11. NO xxx OUTPUTS MATCH UNSATISFIED zzz INPUTS

Check that it was intended to drive component zzz with component xxx or that the inputs to zzz have been previously satisfied by other component connections.

12. TABLE NAME xxx MUST BE FOLLOWED BY A NUMERIC DIMENSION RATHER THAN zzz

When using the ADD TABLES command it is necessary to provide the maximum amount of storage to be allocated for the table as well as the table name. This storage value must be a numeric quantity.

13. THE FOLLOWING COMPONENTS FORM AN IMPLICIT LOOP. MODEL RESULTS WILL BE INVALID. xxx, zzz, .....

Models must be explicit. Implicit loops can often be corrected by inserting a component with a state variable as its output, e.g., a simple linear lag, LA.

All models containing FORTRAN STATEMENTS will receive this warning. It is the users responsibility to assure that the model is explicit.

14. THE SEQUENCE OF THE FOLLOWING COMPONENTS HAS BEEN ALTERED TO FORM AN EXPLICIT MODEL. xxx, zzz, ...

The model component sequence as given contained implicit equations. By altering the component sequence it was possible to form an explicit model.

15. xxx IS NOT A VALID INPUT QUANTITY OR PORT DESIGNATION FOR COMPONENT zzz

The phrase xxx cannot be located as one of the input quantities or input ports of the component zzz. No connections will occur. Check the list of standard components for the proper spelling or port designations for this component.

16. xxx IS NOT A VALID LOCATION NUMBER

The LOCATION command must be followed by a numeric location number.

17. xxx IS NOT A VALID PORT DESIGNATION FOR INPUT COMPONENT zzz. ERRONEOUS CONNECTIONS MAY OCCUR.

The phrase xxx cannot be located as a valid input port for the component zzz. Connections will be attempted using the upstream output port that was identified.

## SECTION III

### STANDARD COMPONENTS

This section describes the standard components that are available for ACLS modeling. The component descriptions are listed alphabetically for each reference. Whenever possible, a one page description of all pertinent information is provided for each component. References are provided for source listings and analysis, where applicable.

Standard Component Name	Description	Page
AB	Air Bag Skid System	28
AC	Aero Coefficients as Tabular Functions	34
AF	Analytic Function of Time	36
AP	Auto Pilot Pitch Controller (Jindivik)	37
AR	Auto Pilot Roll Controller (Jindivik)	39
AS	Arresting System	41
DL	Lateral Aerodynamic Model	46
DS	Six Degree of Freedom Rigid Body Dynamics	50
DU	Simple Duct	52
DV	Valve in a Duct	54
EC	Engine Model (Complex)	56
EJ	Ejector Model	60
ES	Engine Model (Simple)	62
FD	Four Degree of Freedom Rigid Body Dynamics	65
FG	Flight and Ground Controller	67
FH	Fan Model with Hysteresis	69
FL	Ambient Conditions	71
FM	Foster Miller Inelastic Trunk Model	72
FN	Inlet Fan	84
FR	Fan with Surge Analysis	86

Standard Component Name	Description	Page
FS	Flow Split	88
FT	Turbo Fan - ACLS	90
FU	Function Generator - One Input	92
FV	Function Generator - Two Inputs	93
GW	Gust Wind Model	94
IT	Integrator with Saturation	97
LA	Lag Transfer Function (Time Constant Form)	98
LE	Lead Lag Transfer Function (Pole Form)	99
LG	Lag Transfer Function (Pole Form)	100
LL	Lead Lag Transfer Function (Time Constant Form)	101
MA	Multiply and Add (One Input)	102
MB	Multiply, Divide, Add, (Two Inputs)	103
MC	Multiply and Add (Three Inputs)	104
MG	Flow Merge	105
OC	Optimal Controller	107
OL	Longitudinal Aerodynamic Model	108
OO	Foster Miller Output Component	112
PT	Pitch Thruster	113
RA	Random Number Generator	115
RG	Rate Gyro Dynamics and Saturation	116
RT	Roll Thruster	117
SA	Saturation Function	119
SB	Dead Band + Saturation	120
SG	Generalized Six Degree of Freedom Rigid Body Dynamics	122
SV	Sum Linear and Angular Velocities	124
SW	Switch (2 Inputs - 1 Output)	125
SX	Switch (4 Inputs - 2 Outputs)	126
SY	Switch (6 Inputs - 3 Outputs)	127
SZ	Switch (8 Inputs - 4 Outputs)	128
S2	Sum Forces and Moments (2 Sets of Inputs)	129
S3	Sum Forces and Moments (3 Sets of Inputs)	130

Standard Component Name	Description	Page
TA	Tabular Functions of Time (4 Functions)	131
TB	Tabular Functions of Time (2 Functions)	132
TD	Three Degree of Freedom Rigid Body Dynamics (Lateral)	133
TF	Transfer Function $\frac{Z1S + Z0}{S^2 + P1S + P0}$	135
TG	Transform Engine Thrust into Body Axis	136
TK	Inelastic Trunk Model	137
TL	Three Degree of Freedom Rigid Body Dynamics (Longitudinal)	144
TR	Transform Vectors Body to Earth Axis	146
TS	Elastic Trunk Model	148
TT	Two Degree of Freedom Rigid Body Dynamics (Longitudinal)	163
TZ	Transfer Function $\frac{Z2S^2 + Z1S + Z0}{S^2 + P1S + P0}$	164
VA	Aerodynamic Variables from States	165
WS	Steady or Shear Wind Model	167
XP	Transform Angular Rates	168
XT	Transform Torques	169
YC	Yaw Thruster	170

AIR BAG MODEL  
INPUT

AB

PHYSICAL QUANTITY NAME	PORT NO.	DESCRIPTION	UNITS
ABL (A,B,LO, GA,GB)		ARRAYS OF BAG ELEMENT DIMENSIONS: A, B, LO; AND ARRAYS OF ANGULAR POSITION OF FUSELAGE CONSTRAINTS ON MEMBRANE SHAPE	INCHES DEG
XYZ (XA,YA,ZA)		ARRAYS OF COORDINATES OF ELEMENT INBOARD ATTACH POINT:	INCHES
DSM (D,S,MU)		ARRAYS OF: ELEMENT WIDTH, D ELEMENT SCALING FACTORS, S ELEMENT COEFFICIENTS OF FRICTION, MU	INCHES ----- -----
IAL (IS,AP, LP,LH)		ARRAYS OF: ELEMENT SET NUMBER, IS, ORIFICE AREA PER UNIT BAG AREA, AP CIRCUMFERENTIAL DISTANCE FROM OUTB'D ATTACH POINT TO START OF PERFORATIONS, LP; WIDTH OF PERFORATED AREA, LH	----- ----- INCHES INCHES
REL		TABULAR DATA: RELIEF VALVE AREA OPENING  VS BAG PRESSURE (GAGE)	SQ. IN. VS. PSIG
ZTR		VECTOR ARRAY CONTAINING TERRAIN ELEVATION DEFINITION	INCHES
ROL,PIT,YAW		AIRPLANE ROLL, PITCH, YAW EULER ANGLES	DEG
X, ALT		X,Z EARTH AXIS POSITIONS	FT
U,V,W		X,Y,Z BODY AXIS LINEAR VELOCITIES	FT/SEC
PA		AMBIENT PRESSURE	PSIA
VU		BREAK POINT IN MU-VELOCITY CURVE	IN/SEC
EPC		PRINT CONTROL INDICATOR =1 PRINTS ELEMENT VARIABLE VALUES EVERY PRINT INTERVAL	-----
WTR,TTR		FLOW RATE AND TEMPERATURE OF AIR SUPPLY TO RIGHT AIR BAG	LB/MIN, DEGR
WTL,TTL		FLOW RATE AND TEMPERATURE OF AIR SUPPLY TO LEFT AIR BAG	LB/MIN, DEGR
NE		NUMBER OF AIR BAG ELEMENTS: IF NEGATIVE, THE MODEL IS SYMMETRIC ABOUT ROLL AXIS	-----
NST		NUMBER OF ELEMENT SHAPE PARAMETER SETS	-----
NPT		NUMBER OF ELEMENTS IN A ROW OR COLUMN IN THE PARAMETER SET	-----

AIR BAG MODEL  
INPUT

AB

PHYSICAL QUANTITY NAME	PORT NO.	DESCRIPTION	UNITS
BST,WLT		BODY STATION AND WATER LINE OF AIR BAG AXIS	INCHES
CD1		ORIFICE DISCHARGE COEFFICIENT FOR AIR BAG AREA NOT IN CONTACT WITH THE GROUND	-----
CDA		DISCHARGE COEFF. FOR FLOW THROUGH RELIEF VALVE	-----
BSC,WLC		BODY STATION AND WATER LINE OF C.G.	INCHES
TAU		TIME CONSTANT FOR AIR BAG VOLUME RATE OF CHANGE	SEC
P,Q,R		X,Y,Z BODY AXIS ANGULAR VELOCITIES	DEG/SEC
AMO		INDICATOR FOR TYPE OF SURFACE IN TERRAIN MODEL  0 = DEFINES A FLAT SURFACE, ZE=0 1 = DEFINES (1-COSINE) OR SINUSOIDAL SURFACE 2 = DEFINES PROFILE IN TABULAR FORM FOR AMODE = 1	-----
ANR		NUMBER OF SEQUENTIAL (1-COSINE) BUMPS	-----
DL		LENGTH OF BUMP	FEET
H		HEIGHT OF BUMP (NEGATIVE MEANS A DIP) FOR AMODE = 2	INCHES
ANR		NO. OF DATA POINTS IN PROFILE DEF.	-----
DL		INCREMENTAL DISTANCE BETWEEN POINTS	FEET
H		CONSTANT ELEVATION SCALING FACTOR	-----
DMP		BAG DAMPING COEFFICIENT AS A FUNCTION OF BAG FLATTENED AREA	LBS-SEC/IN <sup>3</sup>
CD2		ORIFICE DISCHARGE COEFFICIENT FOR AIR BAG AREA IN CONTACT WITH GROUND	-----

AIR BAG MODEL  
OUTPUT

AB

PHYSICAL QUANTITY NAME	PORT NO.	DESCRIPTION	UNITS
FXT, FYT, FZT		X, Y, Z AXIS, AXIAL, LATERAL AND VERTICAL FORCE SUMMATION TERMS	LBS
TXT, TYT, TZT		X, Y, Z AXIS SUMMATION TERMS FOR ROLL, PITCH AND YAW MOMENTS	FT-LBS
*PTR		AIR BAG PRESSURE, RIGHT SIDE	PSIA
*PTL		AIR BAG PRESSURE, LEFT SIDE	PSIA
*VTR		AIR BAG VOLUME, RIGHT SIDE	CU FT
*VTL		AIR BAG VOLUME, LEFT SIDE	CU FT
WAR		AIR FLOW RATE, BAG TO ATMOSPHERE, RIGHT SIDE	LB/MIN
WAL		AIR FLOW RATE, BAG TO ATMOSPHERE, LEFT SIDE	LB/MIN

\* State variables

References: Analysis -- Volume I, Section VII  
 Listing -- Volume II, Section 4.6.4

AIR BAG MODEL

EQUATIONS:

XBA = BSCG-BST+XA  
 YBA = YA  
 ZBA = WLCG-WLT+ZA  
 CALL ICB(NST,NPT,A,B,LO,GA,GB,DMU,AZO,AYO,AL1,AL3,AAS,BYO,BL1,BL3,BAS)  
 ISI = IS  
 ZOFSU = AZO(ISI)  
 ZOFS = S\*ZOFSU  
  
 YOFS = S\*AYO(1,1,ISI)  
 XBT = XBA  
 YBT = (YBA+YOFS)\*E                      E = 1 (RHS), = -1 (LHS)  
 ZBT = ZBA+ZOFS                          Free Shape  
 XET = X\*12.+XBT\*CPCY+YBT\*(SRSPCY-CRSY)+ZBT\*(SYSR+CYCRSP)  
 ZET = -ALT\*12-XBT\*SP+YBT\*CPSR+ZBT\*CRCP  
 ZEG = TERRA(XET,AMODE,ANR,DL,H,ZTR)  
 ZGAP = -ZEG-ZET  
 ZO = ZOFS+ZGAP  
 ZBT = ZBA+ZO                              Loaded Shape  
 XBTD = ZBT\*Q-YBT\*R+U  
 YBTD = -ZBT\*P+XBT\*R+V  
 ZBTD = YBT\*P-XBT\*Q+W  
 XTD2 = XBTD\*CP+YBTD\*SPSR+ZBTD\*SPCR  
 YTD2 = YBTD\*CR-ZBTD\*SR  
 ZTD = -XBTD\*SP+YBTD\*CPSR+ZBTD\*CRCP  
 VET = SQRT(XTD2\*XTD2+YTD2\*YTD2)  
 UTO = MU\*XMU(VET)  
 UTX = UTO\*XTD2/VET  
 UTY = UTO\*YTD2/VET                      UTX=UTY=0 if VET=0.

LOADED SHAPE:

ZOU = ZO/S  
 UT = E\*UTY  
 YO = S\*TBL2(UT,ZOU,ZOFSU,AYO,DMU,NPT,IS,NA)  
 L1 = S\*TBL2(UT,ZOU,ZOFSU,AL1,DMU,NPT,IS,NA)  
 L3 = S\*TBL2(UT,ZOU,ZOFSU,AL3,DMU,NPT,IS,NA)  
 AS = S\*S\*TBL2(UT,ZOU,ZOFSU,AAS,DMU,NPT,IS,NA)

} UT < 0

AB

AIR BAG MODEL

AS = S\*S\*TBL2(UT,ZOU,ZOFSU,BAS,DMU,NPT,IS,NA)  
 YO = S\*TBL2(UT,ZOU,ZOFSU,BYO,DMU,NPT,IS,NA)  
 L1 = S\*TBL2(UT,ZOU,ZOFSU,BL1,DMU,NPT,IS,NA)  
 L3 = S\*TBL2(UT,ZOU,ZOFSU,BL3,DMU,NPT,IS,NA)  
 AT = D\*L3  
 $\overline{FT} = (PT-PA)*AT$   
 $\overline{FFX} = -UTX*\overline{FT}$   
 $\overline{FFY} = -UTY*\overline{FT}$   
 $\overline{FD} = DMP*AT*ZTD$   
 $\overline{FXT} = FXT+\overline{FFX}$   
 $\overline{FYT} = FYT+\overline{FFY}$   
 $\overline{FZT} = FZT-\overline{FT}-\overline{FD}$   
 $\overline{YBT} = (YBA+YO+.5*L3)*E$   
 $\overline{TXT} = \overline{TXT}+(-(\overline{FT}+\overline{FD})*\overline{YBT}-\overline{FFY}*ZBT)*.08333$   
 $\overline{TYT} = \overline{TYT}+(\overline{FT}+\overline{FD})*\overline{XBT}+\overline{FFX}*ZBT)*.08333$   
 $\overline{TZT} = \overline{TZT}+(\overline{FFY}*XBT-\overline{FFX}*YBT)*.08333$

} UT > 0

FREE SHAPE:

YO = AYO(1,1,ISI)  
 L1 = AL1(1,1,ISI)  
 UTY = 0  
 AS = AAS(1,1,ISI)  
 UTY = 0  
 $\overline{FFX} = \overline{FFY} = \overline{FD} = \overline{FT} = 0$   
 $VTS = VTS+D*AS*.0005787$   
 CALL PERFB(ZGAP,L1,L3,LP,LH,D,AP,AH1,AH2) if AP>0  
 VTSL = VTS  
 AH1L = AH1  
 AH2L = AH2  
 VTSR = VTS  
 AH1R = AH2  
 AH2R = AH2 } M ≠ 2.

RIGHT BAG:

AREL = REL(PTR-PA)  
 CATA = CD1\*AH1R+.6667\*CD2\*AH2R+CDA\*AREL  
 $VTR = (VTSR-VTR)/TAU$   
 CALL FNFLOW(PTR,PA,TTR,CATA,1.,FN,WAR)  
 $PTR = (.0001389*RG*TTR*(WTR-WAR)-1.2*PTR*VTR)/VTR$

LEFT BAG: (for asymmetric model i.e. ANE>0.)

AREL = REL(PTL-PA)  
 CATA = CD1\*AH1L+.6667\*CD2\*AH2L+CDA\*AREL

AB

AIR BAG MODEL

$\dot{VTL} = (VTSL - VTL) / \tau$   
CALL FNFLOW(PTL, PA, TTL, CATA, 1., FN, WAL)  
 $PTL = (.0001389 * RG * TTL * (WTL - WAL) - 1.2 * PTL * \dot{VTL}) / VTL$

SYMMETRIC MODEL:

FXT = 2.\*FXT  
FYT = 0.  
FZT = 2.\*FZT  
TAT = 0.  
TYT = 2.\*TYT  
TZT = 0.  
VTL = VTR  
WAL = WAR  
PTL = PTR

The following abbreviations are used in these equations:

SR = SIN(ROL)	CR = COS(ROL)
SP = SIN(PIT)	CP = COS(PIT)
SY = SIN(YAW)	CY = COS(YAW)

# AC

## AERO COEFFICIENTS AS TABULAR FUNCTIONS

### INPUT

PHYSICAL QUANTITY NAME	PORT NO.	DESCRIPTION	UNITS
CLT		TABULAR DATA: COEFFICIENT OF LIFT VS ANGLE OF ATTACK	---
CDT		TABULAR DATA: COEFFICIENT OF DRAG VS COEFFICIENT OF LIFT	---
CMT		TABULAR DATA: COEFF. OF PITCH MOMENT VS COEFF. OF LIFT	---
CYB		TABULAR DATA: DERIVATIVE, SIDE FORCE DUE TO SIDE SLIP VS ANGLE OF ATTACK	---
CLB		TABULAR DATA: DERIVATIVE, ROLLING MOMENT DUE TO SIDE SLIP VS ANGLE OF ATTACK	---
CNB		TABULAR DATA: DERIVATIVE, YAW MOMENT DUE TO SIDE SLIP VS ANGLE OF ATTACK	---
AL		ANGLE OF ATTACK IN BODY AXIS	DEG
BE		SIDESLIP ANGLE	DEG

### OUTPUT

PHYSICAL QUANTITY NAME	PORT NO.	DESCRIPTION	UNITS
ZO		Z AXIS/LIFT FORCE COEFFICIENT FOR TRIM	LBS
XO		X AXIS/DRAG FORCE COEFFICIENT FOR TRIM	LBS
MO		PITCHING MOMENT COEFFICIENT FOR TRIM	FT-LBS
YB		SIDE FORCE DERIVATIVE	---
LB		ROLL MOMENT DERIVATIVE	---
NB		YAW MOMENT DERIVATIVE	---

References: Listing--Volume II, Section 4.3.10

## AERO COEFFICIENTS AS TABULAR FUNCTIONS

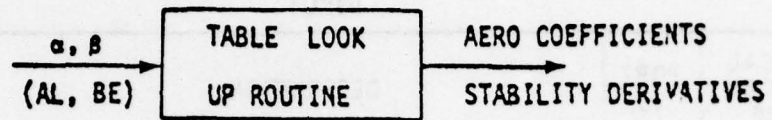

### EQUATIONS:

$$Z_0 = -CLT(AL)$$

$$X_0 = -CDT(Z_0)$$

$$M_0 = CMT(M_0)$$

$$Y_B = CYT(BE)$$

$$L_B = CLB(AL)$$

$$N_B = CNB(AL)$$

# ANALYTIC FUNCTION GENERATOR

# AF

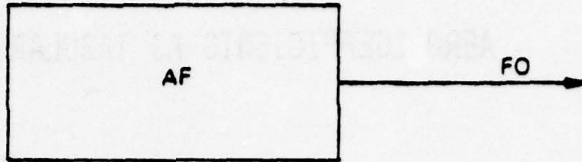

## INPUT

PHYSICAL QUANTITY NAME	PORT NO.	DESCRIPTION	UNITS
COD		Specifies which analytic function is calculated. (see equations below for use of these inputs)	
C1 C2 C3 C4 C5 C6		} Constant inputs for the Equations below	

## OUTPUT

PHYSICAL QUANTITY NAME	PORT NO.	DESCRIPTION	UNITS
FO		Output	Any

References: Listing--Volume II, Section 3.5.7

- COD = 1       $FO = C1 + C2 * SIN(C3 * t + C4)$
- 2             $FO = C1 + C2 * COS(C3 * t + C4)$
- 3             $FO = C1 + e^{-C5 * t} * SIN(C3 * t + C4)$
- 4             $FO = C1 + e^{-C5 * t} * COS(C3 * t + C4)$
- 5             $FO = C1 + C2 * t$
- 6             $FO = C1 + C2 * e^{-C3 * t}$

where: t = TIME

AP

AUTO PILOT PITCH CONTROLLER (JINDIVIK)

INPUT

PHYSICAL QUANTITY NAME	PORT NO.	DESCRIPTION	UNITS
GAM		VERTICAL FLIGHT PATH ANGLE	DEG
GAD		DEMANDED FLIGHT PATH ANGLE	DEG
A1, A2		POSITIVE AND NEGATIVE LIMIT OF DEAD BAND	DEG
A3, A4		POSITIVE AND NEGATIVE FLIGHT PATH ANGLE FOR CONTINUOUS BEEP	DEG
A5, A6		MAX PITCH GYRO REFERENCE ANGULAR RATE	DEG/SEC
A7, A8		SATURATION SLOPE	-----
PGL		PITCH GYRO REFERENCE ANGLE LIMIT	DEG
PIT		AIRCRAFT PITCH ANGLE	DEG
PID		PITCH ANGLE RATE	DEG/SEC
GL1		GAIN FOR REF ANGLE (PITCH) LIMITS	-----
GL2		GAIN FOR INTEGRATION LIMITS ON ELE SERVO ANGLE	-----

OUTPUT

PHYSICAL QUANTITY NAME	PORT NO.	DESCRIPTION	UNITS
ELE		ELEVATOR ANGLE	DEG
ETA*		ELEVATOR SERVO ANGLE	DEG
PGR*		PITCH GYRO REFERENCE ANGLE	DEG
X1*		INTERMEDIATE SERVO FUNCTION STATE	----
X2*		INTERMEDIATE SERVO FUNCTION STATE	----
ELD		ELEVATOR SERVO DEMAND ANGLE FROM AUTO PILOT	DEG

\* State Variables

References: Listing -- Volume II, Section 3.4.9

AP

AUTO PILOT PITCH CONTROLLER (JINDIVIK)

EQUATIONS:

$$GSF = GAM - GAD$$

$$CALL SB(PGF, GSF, A1 . . . . . A8)$$

$$\dot{PGR} = PGF + GL1 * AMIN1(0., PGL - PGR)$$

$$\dot{PGR} = PGF + GL1 * AMAX1(0., -PGL - PGR)$$

$$ELD = 0.28 * (\dot{PIT} - \dot{PGR}) + 0.533 * (PIT - PGR)$$

$$\dot{X1} = 191.6 * (ELD - ETA)$$

$$\dot{X2} = X1 + 61.3 * (ELD - 97.7 * ETA)$$

$$\dot{ETA} = X2 - 9.64 * ETA + GL2 * AMIN1(0., 22.5 - ETA)$$

$$\dot{ETA} = X2 - 9.64 * ETA + GL2 * AMAX1(0., -15. - ETA)$$

$$ELE = ETA / 1.5$$

AR

## AUTO PILOT ROLL CONTROLLER (JINDIVIK)

## INPUT

PHYSICAL QUANTITY NAME	PORT NO.	DESCRIPTION	UNITS
AZI		AIRCRAFT AXIMUTH (+ CLOCKWISE)	DEG
CRS		DEMANDED AIRCRAFT COURSE (+ CLOCKWISE)	DEG
DC		ALLOWABLE COURSE ERROR (+ DEG)	DEG
RØL		AIRCRAFT ROLL ANGLE	DEG
RØD		ROLL ANGLE RATE	DEG/SEC
R		AIRCRAFT YAW RATE	DEG/SEC
GL1		GAIN FOR GYRO REF ANGLE LIMITS	-----
GL2		GAIN FOR INTEGRATION LIMITS ON AILERON SERVO ANGLE	-----

## OUTPUT

PHYSICAL QUANTITY NAME	PORT NO.	DESCRIPTION	UNITS
AIL		AILERON DEFLECTION	DEG
ZET*		AILERON SERVO DEFLECTION	DEG
RGR*		ROLL GYRO REFERENCE ANGLE	DEG
R1*		AILERON DEMAND FUNCTION STATE VARIABLE	---
R2*		AILERON DEMAND FUNCTION STATE VARIABLE	---
X1*		AILERON SERVO FUNCTION STATE VARIABLE	---
X2*		AILERON SERVO FUNCTION STATE VARIABLE	---
AID		AILERON SERVO DEMAND ANGLE FROM AUTO PILOT	DEG

\* State Variables

References: Listing--Volume II, Section 3.4.10

AR

AUTO PILOT ROLL CONTROLLER (JINDIVIK)

EQUATIONS:

$$\text{TRGRD} = 0.0$$

$$\text{IF (AZI} \cdot \text{GT} \cdot \text{CRS} + \text{DC) TRGRD} = -10.0$$

$$\text{IF (AZI} \cdot \text{LT} \cdot \text{CRS} - \text{DC) TRGRD} = 10.0$$

$$\text{IF (AZI} \cdot \text{LT} \cdot \text{DC} \cdot \text{AND} \cdot \text{RGR} \cdot \text{LT} \cdot 0.0) \text{TRGRD} = 10.0$$

$$\text{IF (AZI} \cdot \text{GT} \cdot \text{DC} \cdot \text{AND} \cdot \text{RGR} \cdot \text{GT} \cdot 0.0) \text{TRGRD} = -10.0$$

$$\dot{\text{RGR}} = \text{TRGRD} + \text{GL1} \cdot \text{AMIN1}(0., 30. - \text{RGR})$$

$$\dot{\text{RGR}} = \text{TRGRD} + \text{GL1} \cdot \text{AMAX1}(0., -30. - \text{RGR})$$

$$\dot{\text{R1}} = \text{R}$$

$$\dot{\text{R2}} = \text{R1}$$

$$\text{AID} = .196 \cdot (\text{ROD} - \text{RGR}) + .42 \cdot (\text{ROL} - \text{RGR}) + 0.2 \cdot \text{R} + 0.35 \cdot \text{R1} + 0.0082 \cdot \text{R2}$$

$$\dot{\text{X1}} = 191.6 \cdot (\text{AID} - \text{ZET})$$

$$\dot{\text{X2}} = \text{X1} + 61.3 \cdot (\text{AID} - 97.7 \cdot \text{ZET})$$

$$\dot{\text{ZET}} = \text{X2} - 9.64 \cdot \text{ZET} + \text{GL2} \cdot \text{AMIN1}(0., 24. - \text{ZET})$$

$$\dot{\text{ZET}} = \text{X2} - 9.64 \cdot \text{ZET} + \text{GL2} \cdot \text{AMAX1}(0., -24. - \text{ZET})$$

$$\text{AIL} = \text{ZET} / 3.$$

ARRESTING GEAR MODEL  
INPUT

AS

PHYSICAL QUANTITY NAME	PORT NO.	DESCRIPTION	UNITS
ROL,PIT,YAW		VEHICLE ROLL, PITCH, YAW EULER ANGLES	DEG
X,Y,ALT		VEHICLE CG POSITION IN EARTH AXIS	FT
XD,YD		VEHICLE CG VELOCITY IN EARTH AXIS	FT/SEC
BSC,WLC		BODY STATION AND WATER LINE OF VEHICLE CG	INCHES
BSH,WLH		HOOK PIVOT BODY STATION AND WATER LINE	INCHES
LH		HOOK ARM LENGTH	INCHES
YS		RUNWAY SPAN BETWEEN SHEAVES	FT
YM		TAPE DRUM TO SHEAVE DISTANCE (YM .GT. 5 PERCENT YS)	FT
HC		INITIAL CABLE HEIGHT ABOVE RUNWAY	FT
EC		CABLE MODULUS OF ELASTICITY	LB/IN <sup>2</sup>
DNC		CABLE WEIGHT DENSITY	LB/IN <sup>3</sup>
AC		CABLE CROSS SECTIONAL AREA	IN <sup>2</sup>
ICS		CABLE INITIAL STRESS (USED ONLY FOR KINK WAVE ANGLE CALCULATION)	LB/IN <sup>2</sup>
DNT		TAPE WEIGHT DENSITY	LB/IN <sup>3</sup>
THK		TAPE THICKNESS	INCHES
WDT		TAPE WIDTH	INCHES
TPO		MAXIMUM TAPE PAYOUT	FT
RO		TAPE DRUM OUTSIDE RADIUS	INCHES
IDR		DRUM INERTIA (INCLUDE ALL ROTATING MASS EXCEPT TAPE)	LBS-IN <sup>2</sup>
DMP		WATER TWISTER V <sup>2</sup> DAMPING COEFFICIENT	LB-IN <sup>2</sup> / (RAD/SEC) <sup>2</sup>
VO		VEHICLE SPEED DURING INITIAL CABLE PICKUP	FT/SEC

2A

AS

### ARRESTING GEAR MODEL OUTPUT

PHYSICAL QUANTITY NAME	PORT NO.	DESCRIPTION	UNITS
FX,FY,FZ		X,Y,Z BODY AXIS HOOK FORCES APPLIED AT VEHICLE C.G.	LBS
TX,TY,TZ		X,Y,Z, BODY AXIS HOOK MOMENTS APPLIED AT VEHICLE C.G.	FT-LBS
*GIR		TAPE DRUM ANGULAR DISPLACEMENT, RIGHT SIDE	RADIANS
*G2R		TAPE DRUM ANGULAR VELOCITY, RIGHT SIDE	RAD/SEC
*GIL		TAPE DRUM ANGULAR DISPLACEMENT, LEFT SIDE	RADIANS
*G2L		TAPE DRUM ANGULAR VELOCITY, LEFT SIDE	RAD/SEC
TR,TL		RIGHT, LEFT CABLE/TAPE TENSION	LBS
CIL		HOOK TO CABLE IMPACT LOAD	LBS
THL		TOTAL LOAD APPLIED TO HOOK	LBS

\* State variables

References: Analysis -- Volume I, Section VIII  
Listing -- Volume II, Section 4.6.5

AS

ARRESTING GEAR MODEL

EQUATIONS:

TIME=0  
CALL KINK (U,V,W,CSI,EC,DNC,PKW,C,CSTR)  
IT = 0  
IM = 0  
RI2 = RO\*RO-3.8197\*TPO\*THK  
RI2 = 1.E6 if RI2 < 0  
RI = SQRT(RI2)  
BH = (BSH-BSCG)/12.  
HH = (WLCG-WLH)/12.  
LH2 = ALH/12.  
INTT = 1.5708\*DNT\*WDT  
TRO = .1592\*THK/RO  
APG = .373\*AC\*DNC  
RR = RO  
RL = RO  
TIME > 0.  
FX = FY = FZ = TX = TY = TZ = 0.  
TR = TL = CIL = 0.  
IF(IM.EQ.1) HOOK MISSED THE CABLE  
XEH = X-BH\*CPCY-HH\*SP > 0 FOR CABLE HOOKUP  
YEH = Y  
ZEH = -ALT-BH\*(CRSPCY+SRSY)+HH\*CRCP  
ZL = -ZEH-HC  
XCH = SQRT(ZL\*ZL+XEH\*XEH)  
SINC = ZL/XCH  
COSC = XEH/XCH  
OC = 57.3\*ASIN(SINC)  
YCH = YEH  
AB = XEH\*SY/CY+(ZL/CP-SP\*(ZL\*SP/CP+XEH/CY))\*SR/(SRSPSY+CRCY)  
GG2 = XCH\*XCH+AB\*AB  
GG = SQRT(GG2)  
SIND = XCH/GG  
COSD = AB/GG  
XCP = XCH-LH2\*COSD  
YCP = YCH-LH2\*SIND  
HOOK PASSES OVER CABLE (NO HOOKUP)  
YR = .4\*YS-YCP IT # 1  
YL = .4\*YS+YCP  
D = (XCH-LH2)\*12. XCH > LH2

# AS

## ARRESTING GEAR MODEL

### HOOK ENGAGES CABLE

$AYR = \sqrt{(.5*YS-YCP)*(.5*YS-YCP)+XCP*XCP}$        $IT = 1$  or  
 $AYL = \sqrt{(.5*YS+YCP)*(.5*YS+YCP)+XCP*XCP}$        $XCH \leq LH2$   
 $SPR = (.5*YS-YCP)/AYR$   
 $SPL = (.5*YS+YCP)/AYL$   
 $CPR = XCP/AYR$   
 $CPL = XCP/AYL$   
 $PR = \text{ACOS}(CPR)$   
 $PL = \text{ACOS}(CPL)$   
 $AR = AYR - YR$        $PKW \leq PR$   
 $SPR = \text{SIN}(PKW)$   
 $CPR = \text{COS}(PKW)$        $PKW > PR$   
 $AR = (1.-CPR)*XCP/SPR + .5*YS - YCP - YR$   
 $AL = AYL - YL$        $PKW \leq PL$   
 $SPL = \text{SIN}(PKW)$   
 $CPL = \text{COS}(PKW)$        $PKW > PL$   
 $AL = (1.-CPL)*XCP/SPL + .5*YS + YCP - YL$   
 $ARU = RO*G1R*(1.-.5*TRO*G1R)$   
 $ALU = RO*G1L*(1.-.5*TRO*G1L)$   
 $RR = RO*(1.-TRO*G1R)$   
 $RL = RO*(1.-TRO*G1L)$   
 $UR = (AR-ARU)/(ARU+YM)$   
 $UL = (AL-ALU)/(ALU+YM)$   
 $TR = WDT*THK*ET(UR)$   
 $TL = WDT*THK*ET(UL)$

### IMPACT LOAD

$VS = XD*XD + YD*YD$   
 $AV = YD/XD$   
 $FR = APG*VS*\text{COS}(PKW-AV)/SPR$   
 $FL = APG*VS*\text{COS}(PKW-AV)/SPL$        $PKW > PR$   
 $CIL = FR + FL$        $> PL$   
 $XEG = XEH - ZBG*SP$   
 $YEG = YEH + ZBG*SRCP$   
 $ZEG = ZEH + ZBG*CRCP$   
 $FF2 = XEG^2 + (YEG - YEH + AB)^2 + (ZEG + HC)^2$   
 $EE = ZBG$   
 $\text{COSH} = (EE^2 + GG^2 - FF2)/(2*EE*GG)$   
 $\text{SINH} = \sqrt{1. - \text{COSH}*\text{COSH}}$   
 $OH = 57.3*\text{ACOS}(\text{COSH})$   
 $FCX = -TR*SPR - TL*SPL - CIL$   
 $FCY = TR*CPR - TL*CPL - CIL*AV$   
 $THL = \sqrt{FCX^2 + FCY^2}$

### BODY AXES FORCES AND MOMENTS

$FXEP = FCX*\text{COSC}$   
 $FYEP = FCY$   
 $FZEP = -FCX*\text{SINC}$

AS

## ARRESTING GEAR MODEL

FX = FXEP\*CPCY+FYEP\*(SRSPCY-CRSY)+FZEP\*(CRSPCY+SRSY)  
FY = FXEP\*CPSY+FYEP\*(SRSPSY+CRCY)+FZEP\*(CRSPSY-SRCY)  
FZ = -FXEP\*SP+FYEP\*SRCP+FZEP\*CRCP  
BP = BH+LH2\*SINH  
HP = HH+LH2\*COSH  
TX = -HP\*FY  
TY = HP\*FX+BP\*FZ  
TZ = -BP\*FY  
RI4 = (RI)<sup>4</sup>  
DRR4 = (RR)<sup>4</sup>-RI4;DRL4=(RL)<sup>4</sup>-RI4  
VIR = 386./(INTT\*DRR4+ADR)  
VIL = 386./(INTT\*DRL4+ADR)  
G1R = G2R  
G2R = VIR\*(-DMP\*G2R\*G2R+RR\*TR)  
G1L = G2L  
G2L = VIL\*(-DMP\*G2L\*G2L+RL\*TL)

The following abbreviations are used in these equations:

SR = SIN(ROL)

CR = COS(ROL)

SP = SIN(PIT)

CP = COS(PIT)

SY = SIN(YAW)

CY = COS(YAW)

LATERAL AERODYNAMIC MODEL

DL

INPUT

PHYSICAL QUANTITY NAME	PORT NO.	DESCRIPTION	UNITS
YB, YBD		SIDE FORCE COEFFICIENTS:*	
		BETA AND BETA DOT COEFF. (NONDIM.)	LB-SEC/FT
		V AND V DOT COEFF. (DIM.)	LB-SEC <sup>2</sup> /FT
YP, YR		P AND R ANGULAR RATE COEFF.	LB-SEC/DEG
YDR, YDA		RUDDER AND AILERON COEFF.	LB/DEG
KCY		AEROELASTIC EFFECTS COEFFICIENT	---
YTR		TAKEOFF OR RECOVERY TRUNK COEFFICIENT (NONDIM.)	---
		V COEFFICIENT (DIM.)	LB-SEC/FT
YFS		FLIGHT SPOILERS COEFFICIENT	LB/DEG
YGE		GROUND EFFECT ON CYB FACTOR	---
KYB		LARGE SIDE SLIP ANGLE FACTOR FOR CYB	---
YBR		RUDDER EFFECTIVENESS PARAMETER FOR LARGE SIDE-SLIP ANGLES	---
		ROLLING MOMENT COEFFICIENTS:*	
LB, LBD		BETA AND BETA DOT COEFF. (NONDIM.)	LB-SEC
		V AND V DOT COEFF. (DIM.)	LB-SEC <sup>2</sup>
LP, LR		P AND R ANGULAR RATE COEFF.	FT-LB-SEC
			DEG
LDR, LDA		RUDDER AND AILERON COEFF.	FT-LB/DEG
KCL		AEROELASTIC EFFECTS COEFFICIENT	---
LTR		TRUNK COEFFICIENT (NONDIM.)	LB-SEC
		V COEFFICIENT, (DIM.)	
LFS		FLIGHT SPOILERS COEFFICIENT	FT-LB/DEG
LGE		GROUND EFFECT ON CLB FACTOR	---
KLB		LARGE SIDE SLIP ANGLE FACTOR FOR CLB	---
LBR		RUDDER EFFECTIVENESS PARAMETER FOR LARGE SIDE-SLIP ANGLES	---
		YAWING MOMENT COEFFICIENTS:*	
NB, NBD		BETA AND BETA DOT COEFF. (NONDIM.)	LB-SEC
		V AND V DOT COEFF. (DIM.)	LB-SEC <sup>2</sup>
NP, NR		P AND R ANGULAR RATE COEFF.	FT-LB-SEC
			/DEG
NDR, NDA		RUDDER AND AILERON COEFF.	FT-LB/DEG
KCN		AEROELASTIC EFFECT COEFFICIENT	---
NTR		TRUNK COEFFICIENT (NONDIM.)	---
		V COEFFICIENT (DIM.)	LB-SEC
NFS		FLIGHT SPOILERS COEFFICIENT	FT-LB/DEG
NGE		GROUND EFFECT ON CNB FACTOR	---
KNB		LARGE SIDE SLIP ANGLE FACTOR FOR CNB	---
NBR		RUDDER EFFECTIVENESS PARAMETER FOR LARGE SIDE-SLIP ANGLES	---

DL

## INPUT

PHYSICAL QUANTITY NAME	PORT NO.	DESCRIPTION	UNITS
RUD,AIL, FSP		CONTROL SURFACES:*	
		RUDDER AND AILERON AND FLIGHT SPOILER DEFLECTIONS	DEG
UD, WD		LONGITUDINAL ACCELERATIONS:*	
		X AND Z BODY AXIS ACCEL.	FT/SEC <sup>2</sup>
FY	1	EXTERNAL FORCES AND MOMENTS:*	
TX,TZ	1	Y BODY AXIS FORCE	LBS
		X AND Z BODY AXIS MOMENTS	FT-LBS
MA		CONSTANTS:	
B		RIGID BODY MASS	SLUGS
XP*		WING SPAN	FT
ID		X AXIS CENTER OF PRESSURE - C.G.	FT
		INDICATOR FUNCTION OFR COEFFICIENTS	
		0 = BODY AXIS, DIM.	
		1 = BODY AXIS, NONDIM.	
		2 = STABILITY AXIS, DIM.	
		3 = STABILITY AXIS, NONDIM.	
CAL, SAL		DIRECTION COSINES FOR BODY OR STABILITY AXES, DEPENDING ON ID	
UO,VO,WO		X,Y,Z BODY AXIS VELOCITIES	FT/SEC
PO,RO		X AND Z BODY AXIS ANGULAR RATES	DEG/SEC
BE		SIDSLIP ANGLE	DEG
EV		Y BODY AXIS ACCEL. TERM FOR VD	FT/SEC <sup>2</sup>
VT		TRUE AIRSPEED	FT/SEC
QS		DYNAMIC PRESSURE TIMES REFERENCE AREA	LBS
RW		Y BODY AXIS ANGULAR RATE GUST	DEG/SEC

## OUTPUT

PHYSICAL QUANTITY NAME	PORT NO.	DESCRIPTION	UNITS
FY	2	Y BODY AXIS FORCE SUM	LBS
VD		Y BODY AXIS ACCELERATION	FT/SEC <sup>2</sup>
TX,TZ	2	X AND Z AXIS (ROLL AND YAW) MOMENTS	FT-LBS

References: Analysis -- Volume I, Section 2.4.9  
Listing -- Volume II, Section 4.3.9

\* Default value = 0

DL

LATERAL-DIRECTIONAL EQUATIONS  
(Implicit Form)

DIMENSIONAL EQUATIONS:

$$FY_{aero} = \left\{ \begin{array}{l} (YB \cdot KCY + YTR) \cdot YGE \cdot VO + YBD \cdot (\dot{V} + \dot{V}\dot{W}) + YP \cdot PO + YR \cdot RO + YDA \cdot AIL + YFS \cdot FSD \\ KYB + YDR \cdot RUD \cdot YBR \end{array} \right\} \cdot$$

where

$$\dot{V} = VD = FY2/MA + EW$$

$$\dot{V}\dot{W} = RW \cdot VT \cdot \pi/180$$

$$TX_{aero} = \left\{ \begin{array}{l} (LB \cdot KCL + LTR) \cdot LGE \cdot VO + LBD \cdot (\dot{V} + \dot{V}\dot{W}) + LP \cdot PO + LR \cdot RO + LDA \cdot AIL + LFS \cdot FSP \\ LDR \cdot RUD \cdot LBR \end{array} \right\} \cdot KLB +$$

$$TZ_{aero} = \left\{ \begin{array}{l} (NB \cdot KCN + NTR) \cdot NGE \cdot VO + NBD \cdot (\dot{V} + \dot{V}\dot{W}) + NP \cdot PO + NR \cdot RO + NDA \cdot AIL + NFS \cdot FSP \\ NDR \cdot RUD \cdot NBR \end{array} \right\} \cdot KNB +$$

NONDIMENSIONAL EQUATIONS:

$$FY_{aero} = QS \cdot \left[ \left\{ \begin{array}{l} (YB \cdot KCY + YTR) \cdot YGE \cdot \hat{B}\hat{E} + (YBD \cdot \hat{B}\hat{E}\hat{T}A + YP \cdot \hat{P} + YR \cdot \hat{R}) \cdot B / (2 \cdot VT) + YDA \cdot \hat{A}\hat{I}\hat{L} + \\ YFS \cdot \hat{F}\hat{S}\hat{P} \end{array} \right\} \cdot KYB + YDR \cdot \hat{R}\hat{U}\hat{D} \cdot YBR \right]$$

where

$$\hat{B}\hat{E}\hat{T}A = \dot{V} (1 - \hat{B}\hat{E}^2) / VT - \hat{B}\hat{E} (UO \cdot UD + WO \cdot WD) / VT^2 + \hat{R}\hat{W} *$$

$$\hat{B}\hat{E} = BE \cdot \pi / 180, \text{ etc. for } \hat{P}, \hat{R}, \hat{R}\hat{U}\hat{D}, \hat{A}\hat{I}\hat{L}, \hat{R}\hat{W}, \hat{F}\hat{S}\hat{P}$$

$$TX_{aero} = QS \cdot B \cdot \left[ \left\{ \begin{array}{l} (LB \cdot KCL + LTR) \cdot LGE \cdot \hat{B}\hat{E} + (LBD \cdot \hat{B}\hat{E}\hat{T}A + LP \cdot \hat{P} + LR \cdot \hat{R}) \cdot B / (2 \cdot VT) + LDA \cdot \hat{A}\hat{I}\hat{L} + \\ LFS \cdot \hat{F}\hat{S}\hat{P} \end{array} \right\} \cdot KLB + LDR \cdot \hat{R}\hat{U}\hat{D} \cdot LBR \right]$$

$$TZ_{aero} = QS \cdot B \cdot \left[ \left\{ \begin{array}{l} (NB \cdot KCN + NTR) \cdot NGE \cdot \hat{B}\hat{E} + (NBD \cdot \hat{B}\hat{E}\hat{T}A + NP \cdot \hat{P} + NR \cdot \hat{R}) \cdot B / (2 \cdot VT) + NDA \cdot \hat{A}\hat{I}\hat{L} + \\ NFS \cdot \hat{F}\hat{S}\hat{P} \end{array} \right\} \cdot KNB + NDR \cdot \hat{R}\hat{U}\hat{D} \cdot NBR \right]$$

FORCE AND TORQUE SUM:

$$FY2 = FY_{aero} + FY1$$

$$TX2 = \begin{pmatrix} TX_{aero} + TX1 & ID = 0,1 \\ TX_{aero} \cdot CAL - TZ_{aero} \cdot SAL + TX1 & ID = 2,3 \end{pmatrix}$$

$$TZ2 = \begin{pmatrix} TZ_{aero} + TZ1 + XP \cdot FY_{aero} & ID = 0,1 \\ TZ_{aero} \cdot CAL + TX_{aero} \cdot SAL + XP \cdot FY_{aero} & ID = 2,3 \end{pmatrix}$$

\*Small Beta angle approximation

# DL

## LATERAL STABILITY AND CONTROL DERIVATIVES: DL

	BETA	BETA	P	R	$\delta$ RUD.	$\delta$ AIL.
FY (SIDE)	$C_{Y\beta}$ YB	$C_{Y\dot{\beta}}$ YBD	$C_{Yp}$ YP	$C_{Yr}$ YR	$C_{Y\delta r}$ YDR	$C_{Y\delta a}$ YDA
TX=L (ROLL)	$C_{L\beta}$ LB	$C_{L\dot{\beta}}$ LBD	$C_{Lp}$ LP	$C_{Lr}$ LR	$C_{L\delta r}$ LDR	$C_{L\delta a}$ LDA
TZ=N (YAW)	$C_{N\beta}$ NB	$C_{N\dot{\beta}}$ NBD	$C_{Np}$ NP	$C_{Nr}$ NR	$C_{N\delta r}$ NDR	$C_{N\delta a}$ NDA
	TRUNK	SPOILERS	GROUND EFFECT	LARGE SIDE SLIP	$\beta$ RUD	AERO ELASTICITY
	$C_{YTR}$ YTR	$C_{YFS}$ YFS	$K_{CYGE}$ YGE	$K_{CYB}$ KYB	$K_{CYBR}$ YBR	$K_{CY}$ KCY
	$C_{LTR}$ LTR	$C_{LFS}$ LFS	$K_{CLGE}$ LGE	$K_{CLB}$ KLB	$K_{CLBR}$ LBR	$K_{CL}$ KCL
	$C_{NTR}$ NTR	$C_{NFS}$ NFS	$K_{CNGE}$ NGE	$K_{CNB}$ KNB	$K_{CNBR}$ NBR	$K_{CN}$ KCN

FIRST ROW = NON-DIM. AERO-COEFFICIENTS

SECOND ROW = EASY NAMES

# SIX DEGREE OF FREEDOM RIGID BODY DYNAMICS

# DS

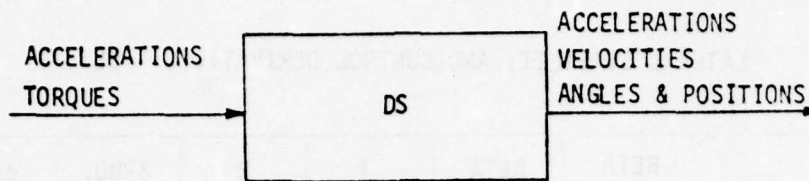

## INPUT

PHYSICAL QUANTITY NAME	PORT NO.	DESCRIPTION	UNITS
UD,VD,WD TX,TY,TZ IXX,IYY IZZ IXZ		X,Y,Z BODY AXIS LINEAR ACCELERATIONS X,Y,Z BODY AXIS TORQUES X,Y,Z BODY AXIS MOMENTS OF INERTIA  X-Z CROSS PRODUCT OF INERTIA	FT/SEC <sup>2</sup> FT-LBS SLUG-FT <sup>2</sup>  SLUG-FT <sup>2</sup>

## OUTPUT

PHYSICAL QUANTITY NAME	PORT NO.	DESCRIPTION	UNITS
*U,V,W *P,Q,R *ROL,PIT, YAW ROD, PID XD, YD *ALT PD,QD,RD		X,Y,Z BODY AXIS LINEAR VELOCITIES X,Y,Z BODY AXIS ANGULAR RATES EULER ANGLES, BODY TO INERTIAL AXES  ROLL, PITCH ANGLE RATES HORIZONTAL POSITION RAIES VERTICAL ALTITUDE FROM SEA-LEVEL X,Y,Z BODY AXIS ANGULAR ACCELERATIONS	FT/SEC DEG/SEC DEG  DEG/SEC FT/SEC FT DEG/SEC <sup>2</sup>

### ASSUMPTIONS:

1. Body axis symmetry about X-Z plane, i.e.,  $IXY = IYZ = 0$ .
2. Constant gravity, flatearth model.
3. Rigid Body

\* These output quantities are states.

Note: If using only OL or DL, the unused inputs must be set to zero.

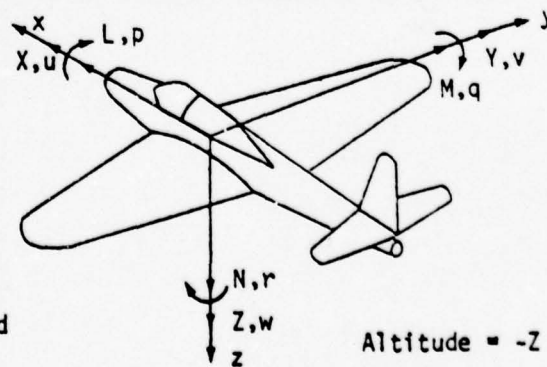

## SIX DEGREE OF FREEDOM EQUATIONS OF MOTION

## o LINEAR VELOCITY EQUATIONS

$$\dot{U} = UD \quad \dot{V} = VD \quad \dot{W} = WD$$

o ANGULAR VELOCITY EQUATIONS ( $\hat{P}=P \cdot \pi/180$ , etc. for  $\hat{Q}, \hat{R}, \hat{P}, \hat{Q}, \hat{R}$ )

$$\hat{P} \cdot I_{XX} = TX - \hat{Q} \cdot \hat{R} \cdot (IZZ - IYY) + (\hat{P} \cdot \hat{Q} + \hat{R}) \cdot IXZ$$

$$\hat{Q} \cdot I_{YY} = TY - \hat{P} \cdot \hat{R} \cdot (I_{XX} - I_{ZZ}) + (\hat{R}^2 - \hat{P}^2) \cdot IXZ$$

$$\hat{R} \cdot I_{ZZ} = TZ - \hat{Q} \cdot \hat{P} \cdot (I_{YY} - I_{XX}) + (\hat{P} \cdot \hat{Q} - \hat{R}) \cdot IXZ$$

## o ANGULAR POSITION EQUATIONS\*

$$P \dot{I}T = Q \cdot CR - R \cdot SR$$

$$Y \dot{A}W = (Q \cdot SR + R \cdot CR) / CP$$

$$R \dot{O}L = P + Y \dot{A}W \cdot SP$$

## o LINEAR POSITION EQUATIONS\*

$$X \dot{D} = U(CY \cdot CP) + V(-SY \cdot CR + CY \cdot SP \cdot SR) + W(SY \cdot SR + CY \cdot SP \cdot CR)$$

$$Y \dot{D} = U(SY \cdot CP) + V(CY \cdot CR + SY \cdot SP \cdot SR) + W(-CY \cdot SR + SY \cdot SP \cdot CR)$$

$$A \dot{L}T = U \cdot SP - V(CP \cdot SR) - W(CP \cdot CR)$$

\* The following abbreviations are used in these equations:

$$SR = \sin(ROL)$$

$$CR = \cos(ROL)$$

$$SP = \sin(PIT)$$

$$CP = \cos(PIT)$$

$$SY = \sin(YAW)$$

$$CY = \cos(YAW)$$

References: Analysis -- Volume I, Section 2.4.2  
Listing -- Volume II, Section 4.3.2

DUCT

DU

INPUT

PHYSICAL QUANTITY NAME	PORT NO.	DESCRIPTION	UNITS
T	1	INLET TEMPERATURE	DEGR
W	1	INLET FLOW	LB/MIN
P	2	OUTLET PRESSURE	PSIA
AK		K FACTOR	---
AL		LENGTH	FT
D		DIAMETER	IN
TAM		EFFECTIVE LOCAL AMBIENT TEMP	DEGR
HO		EXTERNAL HEAT TRANSFER COEFFICIENT (BASED ON INTERNAL WETTED AREA)	BTU/FT2- HR DEGR
FC		FREQUENCY CONTROL ON P1. (FC.GE.1.) A VALUE OF FC GREATER THAN 1. DECREASES FREQUENCY RESPONSE OF P1 CORRESPONDINGLY	---

OUTPUT

PHYSICAL QUANTITY NAME	PORT NO.	DESCRIPTION	UNITS
T	2	OUTLET TEMPERATURE	DEGR
W	2	OUTLET FLOW	LB/MIN
*P	1	INLET PRESSURE STATE	PSIA

References: Analysis -- Volume I, Section 3.1.1  
 Listing -- Volume II, Section 4.1.1

\* State Variables

## DUCT

## EQUATIONS:

$$CP = SHCP(T1, 0.)$$

$$R = 53.3$$

$$GAMMA = 1. + R / (778. * CP - R)$$

$$G1 = 1. / (GAMMA - 1.)$$

$$G2 = (GAMMA - 1.) / 2.$$

$$CA = .785398 * D * D$$

$$CALL FNFLOW(P1, P2, T1, CA, AK, FN, W2)$$

$$\bar{W} = (ABS(W1) + ABS(W2)) / 2.$$

$$\bar{W} = AMAX1(\bar{W}, .01)$$

$$HINT = HI(1, T1, T1, \bar{W}, D, AL)$$

$$UA = 0.004363 * D * AL * HINT * HO / (HINT + HO)$$

$$T2 = TAM + (T1 - TAM) / EXP(UA / (CP * \bar{W}))$$

$$T2 = T1 - 300 \quad T1 > T2$$

$$T2 = T1 + 300 \quad T2 > T1$$

$$\bar{T} = (T1 + T2) / 2.$$

$$\bar{P} = (P1 + P2) / 2.$$

$$AM = AMACH(\bar{P}, \bar{T}, CA, \bar{W})$$

$$\dot{P}1 = R * \bar{T} * (W1 - W2) * (1. + G2 * AM * AM) ** G1 / (60. * CA * AL * FC)$$

# VALVE IN A DUCT

# DV

## INPUT

PHYSICAL QUANTITY NAME	PORT NO.	DESCRIPTION	UNITS
T	1	INLET TEMPERATURE	DEGR
W	1	INLET FLOW	LB/MIN
P	2	OUTLET PRESSURE	PSIA
OPE		VALVE OPENING VAL=1. DEGREES OPEN (0.LE.OPE.LE.90) VAL=2,3. FRACTIONAL OPENING (0.LE.OPEN.LE.1.)	---
AL		LENGTH	FT
D		DIAMETER	IN
DPO		POPPET DIAMETER (REQUIRED FOR GLOBE VALVES ONLY)	IN
TAM		EFFECTIVE LOCAL AMBIENT TEMP	DEGR
HO		EXTERNAL HEAT TRANSFER COEFFICIENT (BASED ON INTERNAL WETTED AREA)	BTU/FT2-HR DEGR
FC		FREQUENCY CONTROL ON P1. (FC.GE.1.) A VALUE OF FC GREATER THAN 1. DECREASES FREQUENCY RESPONSE OF P1 CORRESPONDINGLY	---
VAL		CODE IDENTIFYING TYPE OF VALVE =1. BUTTERFLY VALVE =2. GATE VALVE =3. GLOBE VALVE	---

## OUTPUT

PHYSICAL QUANTITY NAME	PORT NO.	DESCRIPTION	UNITS
T	2	OUTLET TEMPERATURE	DEGR
W	2	OUTLET FLOW	LB/MIN
*P	1	INLET PRESSURE	PSIA

References: Analysis -- Volume I, Section 3.1.4

Listing -- Volume II, Section 4.1.4

\* State Variable

DV

VALVE IN A DUCT

EQUATIONS:

SAME AS DU

CA = . . . .

CALL VLX(P1,P2,T1,D,DPO,OPE,VAL,W2)

$\bar{W} = (\text{ABS}(W1)+\text{ABS}(W2))/2. \quad \geq .01$

HINT = HI (1,T1,T1, $\bar{W}$ ,D,AL)

UA = 0.004363\*D\*AL\*HINT\*HO/(HINT+HO)

T2 = TAM+(T1-TAM)/EXP(UA/(CP\*W))

T2 = T1-300      T1>T2

T2 = T1+300      T2>T1

$\bar{T} = (T1+T2)/2.$

$\bar{P} = (P1+P2)/2.$

AM = AMACH( $\bar{P}$ , $\bar{T}$ ,CA, $\bar{W}$ )

$\dot{P}1 = R*\bar{T}*(W1-W2)*(1.+G2*AM*AM)**G1/(60.*CA*AL*FC)$

## ENGINE MODEL (COMPLEX)

EC

## INPUT

PHYSICAL QUANTITY NAME	PORT NO.	DESCRIPTION	UNITS
PR		TABULAR DATA: COMMAND PRESSURE RATIO VS THRUST LEVER ANGLE (THT)	
WN2		TABULAR DATA: NATURAL FREQUENCY SQUARED VS ACTUAL ENGINE PRESSURE RATIO (PRØ)	
TFT		TABULAR DATA: ENGINE FORWARD THRUST VS MACH NO. (AMN) AND PRØ	
TRT		TABULAR DATA: ENGINE REVERSE THRUST VS MACH NO. (AMN) AND PRØ	
TSR		TABULAR DATA: ENGINE SPEED VS MACH NO. AND INSTANTANEOUS THRUST	
TFN		TABULAR DATA: TEMPERATURE RISE FAN-INLET TO OUTLET VS CORRECTED ENGINE SPEED	
TFP		TABULAR DATA: PRESSURE RATIO FAN OUTLET TO INLET VS CORRECTED ENGINE SPEED	
TBT		TABULAR DATA: TEMPERATURE RISE COMPRESSOR INLET TO OUTLET VS CORRECTED ENGINE SPEED	
TBP		TABULAR DATA: PRESSURE RATIO COMPRESSOR OUTLET TO INLET VS CORR. ENGINE SPEED	
TPO		TABULAR DATA: CORRECTED BLEED FLOW RATE VS ENGINE PORT PRESSURE RATIO	
THT		THRUST LEVER ANGLE	DEG
C1		POSITIVE DEADBAND ON THT	---
C2		NEGATIVE DEADBAND ON THT	---
C3		POSITIVE SATURATION INTERCEPT (.GT.C1)	---
C4		NEGATIVE SATURATION INTERCEPT (.LT.C2)	---
C5		POSITIVE SATURATION LIMIT ON THT	---
C6		NEGATIVE SATURATION LIMIT ON THT	---
C7		SATURATION SLOPE (+VE)	---
C8		SATURATION SLOPE (-VE)	---
TC1		ENGINE SPINDOWN TIME CONSTANT	SEC
ZTA		SPINUP DAMPING RATIO	---
AMN		MACH NUMBER	---
TC2		THRUST REVERSER TIME CONSTANT	SEC
GAX, GAZ		X, Z BODY AXIS DIRECTION COSINES	---
XO, ZO		THRUST LOCATION COMPONENTS FROM C.G.	FT
PAM		AMBIENT PRESSURE	PSIA

EC

ENGINE MODEL (COMPLEX)

INPUT

PHYSICAL QUANTITY NAME	PORT NO.	DESCRIPTION	UNITS
TAM	2	AMBIENT TEMPERATURE	DEGR
P		BLEED PRESSURE DOWNSTREAM OF THE PORT	PSIA
IFN		INDICATOR FUNCTION FOR ENGINE FAN AIR CALCULATIONS 0 = TO BE INCLUDED 1 = TO BE EXCLUDED	---
IBL		INDICATOR FUNCTION FOR ENGINE BLEED AIR CALCULATIONS 0 = TO BE INCLUDED 1 = TO BE EXCLUDED	---
FX1		EXTERNAL FORCE X-BODY-AXIS	LBS

OUTPUT

PHYSICAL QUANTITY NAME	PORT NO.	DESCRIPTION	UNITS
PR0*	2	ACTUAL ENGINE PRESSURE RATIO	---
PRR*		REVERSE ENGINE PRESSURE RATIO	---
X2*		INTERMEDIATE VALUE OF PR0	---
X3*		INTERMEDIATE VALUE OF PRR	---
FX, FZ		X AND Z AXIS FORCES	LBS
TY		Y AXIS TORQUE (PITCHING MOMENT)	FT-LBS
TH		ENGINE THRUST	LBS
FSP		FAN STAGE DELIVERY PRESSURE	PSIA
FST		FAN STAGE DELIVERY TEMPERATURE	DEGR
BPU		BLEED PRESSURE UPSTREAM OF PORT	PSIA
TPU	BLEED TEMPERATURE UPSTREAM OF PORT	DEGR	
W	2	BLEED AIR FLOW RATE	LB/MIN
T	2	BLEED TEMPERATURE DOWNSTREAM OF PORT	DEGR

References: Analysis -- Volume I, Section 2.6  
Listing -- Volume II, Section 4.4.2

\* State Variables

## ENGINE MODEL (COMPLEX)

## EQUATIONS:

```
CALL SB(THT,THT,C1. . . . .C8)
PRI = PR(THT)
EPS = PRI-PRO
EP1 = AMAX1(EPS,0.)
EP2 = AMIN1(EPS,0.)
X3 = (EP2-X3)/TC1
WNS = WNT(PRO)
EM1 = EP1*WNS
WN = SQRT(WNS)
X2 = EM1-2.*WN*ZTA*X2
PRO = X2+X3
TF = TFT(AMN,PRO)
PRR = (PRO-PRR)/TC2
TR = TRT(AMN,PRR)
TH = TR+TF+FX1
FX = TH*GAMX
FZ = TH*GAMZ
TY = ZO*FX-XO*FZ
PT = PAM*(1.+2*AMN*AMN)**3.5
TT = TAM*(1.+2*AMN*AMN)
SPD = TSR(AMN,TH)
ENC = SPD*SQRT(519./TT)
DTF = TFN(ENC)
FST = TT*(1.+DTF)
FPR = TFP(ENC)
FSP = PT*FPR
```

EC

ENGINE MODEL (COMPLEX)

EQUATIONS: (Continued)

DT = TBT(ENC)  
TPU = TT\*(1.+DT)  
CPR = TBP(ENC)  
PPU = PT\*CPR  
PRAT = PPU/P2  
WCR = TPO( PRAT)  
W2 = WCR\*PPU/SQRT(TPU)  
T2 = TPU

# EJ

## EJECTOR MODEL

### INPUT

PHYSICAL QUANTITY NAME	PORT NO.	DESCRIPTION	UNITS
TAB		TABULAR DATA: FLOW RATIO (TOTAL/PRIMARY) VS PRESSURE RATIOS (TOTAL/ SECONDARY) AND (PRIMARY/SECONDARY)	---
P	2	INLET PRESSURE SECONDARY AIR SOURCE	PSIA
T	2	INLET TEMPERATURE SECONDARY SOURCE	DEGR
ANT		NOZZLE THROAT AREA	SQ FT
ANE		NOZZLE EXIT AREA	SQ FT
AK		CONVERGENT-DIVERGENT NOZZLE DIFFUSER LOSS FACTOR (FOR CONVERGENT NOZZLE, INPUT AK=0, ANE=ANT)	---
P	3	OUTLET PRESSURE	PSIA
W	1	INLET FLOW RATE, PRIMARY SOURCE	LB/MIN
T	1	INLET TEMPERATURE, PRIMARY SOURCE	DEGR

### OUTPUT

PHYSICAL QUANTITY NAME	PORT NO.	DESCRIPTION	UNITS
P*	1	INLET PRESSURE, PRIMARY SOURCE	PSIA
W	3	TOTAL OUTLET FLOW	LB/MIN
T	3	OUTLET TEMPERATURE	DEGR

References: Analysis -- Volume I, Section 3.2.1  
Listing -- Volume II, Section 4.2.1

\* State Variables

# EJ

## EJECTOR MODEL

### EQUATIONS:

$GAMMA = 1.4$   
 $WCHO = 31.9 * ANT * P1 / SQRT(T1)$   
 $P1CAL = W1 * SQRT(T1) / (31.9 * ANT)$       CHOKED FLOW  
 $\dot{P}1 = (P1CAL - P1) / .01$   
 $AM = AMACH(P1, T1, ANT, W1)$       NOT CHOKED  
 $PTS = P1 / (1. + (GAMMA - 1.) * AM * AM / 2.) ** (GAMMA / (GAMMA - 1.))$   
 $AQ = P1 - PTS$   
 $ALOSS = AQ * AK$   
 $PE = P1 - ALOSS$   
 $AME = AMACH(PE, T1, ANE, W1)$   
 $PESCAL = PE / (1. + (GAMMA - 1.) * AME * AME / 2.) ** (GAMMA / (GAMMA - 1.))$   
 $PERR = P2 - PESCAL$   
 $\dot{P}1 = PERR / .01$   
 $PRAT1 = P3 / P2$   
 $PRAT2 = P1 / P2$   
 $WRAT = TAB(PRAT1, PRAT2)$   
 $C1 = W1 * SQRT(T1) * WRAT$   
 $C2 = C1 / (W1 * (T1 - T2))$   
 $B = 2. * T2 + 1. / (C2 * C2)$   
 $T3 = (B + SQRT(B * B - 4. * T2 * T2)) / 2.$   
 $W3 = C1 / SQRT(T3)$

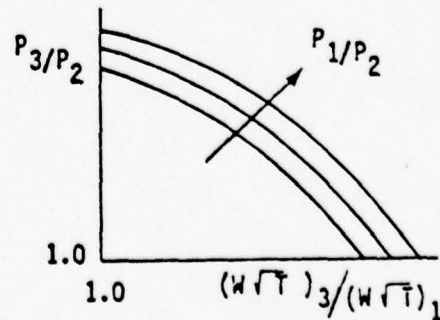
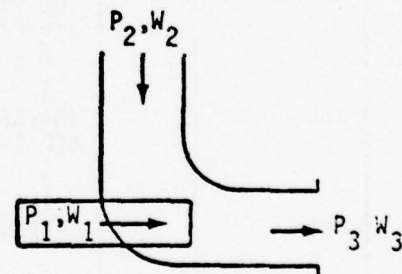

ENGINE MODEL (SIMPLE)

ES

INPUT

PHYSICAL QUANTITY NAME	PORT NO.	DESCRIPTION	UNITS
TSR		TABULAR DATA: ENGINE SPEED VS MACH NO. AND INSTANTANEOUS THRUST	
TFN		TABULAR DATA: TEMPERATURE RISE FAN-INLET TO OUTLET VS CORRECTED ENGINE SPEED	
TFP		TABULAR DATA: PRESSURE RATIO FAN OUTLET TO INLET VS CORRECTED ENGINE SPEED	
TBT		TABULAR DATA: TEMPERATURE RISE COMPRESSOR INLET TO OUTLET VS CORRECTED ENGINE SPEED	
TBP		TABULAR DATA: PRESSURE RATIO COMPRESSOR OUTLET TO INLET VS CORR. ENGINE SPEED	
TPO		TABULAR DATA: CORRECTED BLEED FLOW RATE VS ENGINE PORT PRESSURE RATIO	
TCØ		ENGINE TIME CONSTANT	SEC
THR		REQUIRED THRUST LEVEL	LBS
AMN		MACH NUMBER	---
GAX, GAZ		X, Z BODY AXIS DIRECTION COSINES	---
XO, ZO		THRUST LOCATION COMPONENTS FROM C.G.	FT
PAM		AMBIENT PRESSURE	PSIA
TAM		AMBIENT TEMPERATURE	DEGR
P	2	BLEED PRESSURE DOWNSTREAM OF PORT	PSIA
IFN		INDICATOR FUNCTION FOR ENGINE FAN AIR CALCULATIONS: 0 = TO BE INCLUDED 1 = TO BE EXCLUDED	---
IBL		INDICATOR FUNCTION FOR ENGINE BLEED AIR CALCULATIONS: 0 = TO BE INCLUDED 1 = TO BE EXCLUDED	---
FX1		EXTERNAL FORCE X-BODY AXIS	LBS

ENGINE MODEL (SIMPLE)

OUTPUT

PHYSICAL QUANTITY NAME	PORT NO.	DESCRIPTION	UNITS
TH*		THRUST OUTPUT	LBS
FX, FZ		X, Z BODY AXIS FORCES	LBS
TY		Y AXIS TORQUE (PITCHING MOMENT)	FT-LBS
FSP		FAN STAGE DELIVERY PRESSURE	PSIA
FST		FAN STAGE DELIVERY TEMPERATURE	DEGR
PPU		BLEED PRESSURE UPSTREAM OF PORT	PSIA
TPU		BLEED TEMPERATURE UPSTREAM OF PORT	DEGR
W	2	BLEED FLOW RATE	LB/MIN
T	2	BLEED TEMPERATURE DOWNSTREAM OF PORT	DEGR

Reference: Analysis -- Volume I, Section 2.6.1  
 Listing -- Volume II, Section 4.4.1

\* State Variables

ES

ENGINE MODEL (SIMPLE)

EQUATIONS:

$\dot{TH} = (THR-TH)/TCO$   
 $TH = TH+FX1$   
 $FX = TH * GAMX$   
 $FZ = TH * GAMZ$   
 $TY = ZO * FX - XO * FZ$   
 $PT = PAM * (1. + .2 * AMN * AMN) ** 3.5$   
 $TT = TAM * (1. + .2 * AMN * AMN)$   
 $SPD = TSR(AMN, TH)$   
 $ENC = SPD * SQRT(519. / TT)$   
 $DTF = TFN(ENC)$   
 $FST = TT * (1. + DTF)$   
 $FPR = TFP(ENC)$   
 $FSP = PT * FPR$   
 $DT = TBT(ENC)$   
 $TPU = TT * (1. + DT)$   
 $CPR = TBP(ENC)$   
 $PPU = PT * CPR$   
 $PRAT = PPU / P2$   
 $WCR = TPO (PRAT)$   
 $W2 = WCR * PPU / SQRT(TPU)$   
 $T2 = TPU$

# FD

## FOUR DEGREE OF FREEDOM RIGID BODY DYNAMICS

### INPUT

PHYSICAL QUANTITY NAME	PORT NO.	DESCRIPTION	UNITS
UD, VD TX, TZ IXX, IZZ IXZ PIT		X, Y BODY AXIS LINEAR ACCELERATIONS X, Z BODY AXIS TORQUES X, Z BODY AXIS MOMENTS OF INERTIA X-Z CROSS PRODUCT OF INERTIA PITCH ANGLE (BODY TO INERTIAL AXES)	FT/SEC <sup>2</sup> FT-LBS SLUG-FT <sup>2</sup> SLUG-FT <sup>2</sup> DEG

### OUTPUT

PHYSICAL QUANTITY NAME	PORT NO.	DESCRIPTION	UNITS
*U, V *P, R *ROL, YAW XD, YD *ALT PD, RD		X, Y BODY AXIS LINEAR VELOCITIES X, Z BODY AXIS ANGULAR RATES ENTER ANGLES, BODY TO INERTIAL AXES HORIZONTAL POSITION RATES VERTICAL ALTITUDE FROM SEA-LEVEL X, Z BODY AXIS ANGULAR ACCELERATIONS	FT/SEC DEG/SEC DEG FT/SEC FT DEG/SEC <sup>2</sup>

\* State Variables

## FOUR DEGREE OF FREEDOM EQUATIONS OF MOTION

## o LINEAR VELOCITY EQUATIONS

$$\dot{U} = U_D \quad \dot{V} = V_D$$

o ANGULAR VELOCITY EQUATIONS ( $\hat{P}=P \cdot \pi/180$ , etc. for  $\hat{R}, \hat{P}, \hat{R}$ )

$$\hat{P} \cdot I_{XX} = T_X + \hat{P} \cdot I_{XZ}$$

$$\hat{R} \cdot I_{ZZ} = T_Z + \hat{P} \cdot I_{XZ}$$

## o ANGULAR POSITION EQUATIONS\*

$$YAW = R \cdot CR / CP$$

$$ROL = P + YAW \cdot SP$$

## o LINEAR POSITION EQUATIONS\*

$$X_D = U(CY \cdot CP) + V(-SY \cdot CR + CY \cdot SP \cdot SR)$$

$$Y_D = U(SY \cdot CP) + V(CY \cdot CR + SY \cdot SP \cdot SR)$$

$$ALT = U \cdot SP - V(CP \cdot SR)$$

\*The following abbreviations are used in these equations:

$$SR = \sin(ROL)$$

$$CR = \cos(ROL)$$

$$SP = \sin(PIT)$$

$$CP = \cos(PIT)$$

$$SY = \sin(YAW)$$

$$CY = \cos(YAW)$$

References: Analysis -- Volume I, Section 2.4.3  
Listing -- Volume II, Section 4.3.3

# FLIGHT AND GROUND CONTROLLER

# FG

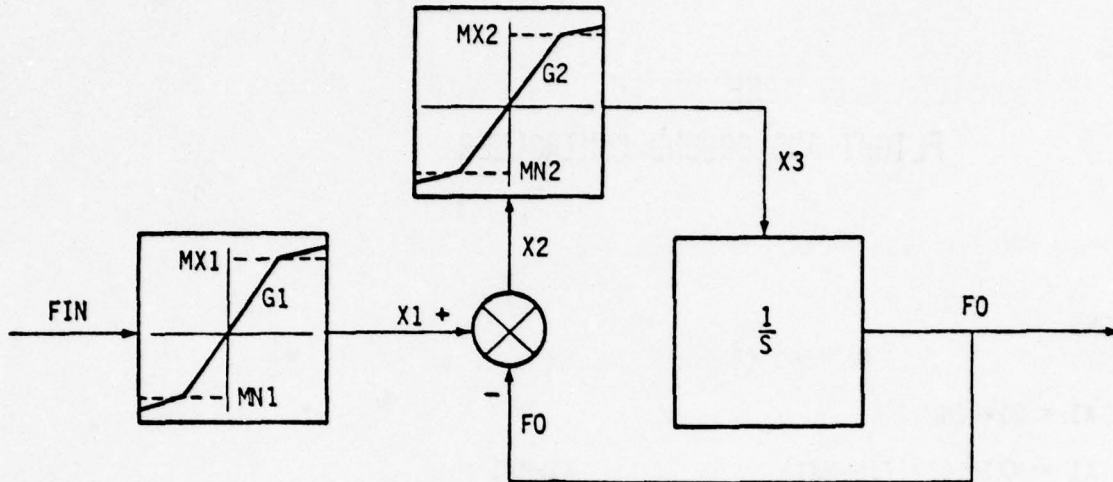

### INPUT

PHYSICAL QUANTITY NAME	PORT NO.	DESCRIPTION	UNITS
FIN		COMMAND SIGNAL	-----
G1		GAIN (SLOPE) FOR COMMAND SIGNAL INPUT	
MX1		UPPER LIMIT OF SATURATION ON FIN	
MN1		LOWER LIMIT OF SATURATION ON FIN	
G2		LOOP GAIN (SLOPE) FOR THE INTEGRATOR	
MX2		UPPER LIMIT OF SATURATION ON X2	
MN2		LOWER LIMIT OF SATURATION ON X2	

### OUTPUT

PHYSICAL QUANTITY NAME	PORT NO.	DESCRIPTION	UNITS
*FO		CONTROLLER OUTPUT	

References: Listing -- Volume II, Section 3.4.8

\* State Variables

FG

## FLIGHT AND GROUND CONTROLLER

### EQUATIONS:

$$X1 = G1*FIN$$

$$X1 = MX1+.01*(FIN-MX1)$$

$$X1 > MX1$$

$$X1 = MN1+.01*(FIN-MN1)$$

$$X1 < MN1$$

$$X2 = X1-F0$$

$$X3 = G2*X2$$

$$X3 = MX2+.01*(X2-MX2/G2)$$

$$X3 > MX2$$

$$X3 = MN2+.01*(X2-MN2/G2)$$

$$X3 < MN2$$

$$F0 = X3$$

## FAN WITH HYSTERESIS

### INPUT

PHYSICAL QUANTITY NAME	PORT NO.	DESCRIPTION	UNITS
CF		TABULAR DATA: FAN FLOW RATE (FORWARD) VS PRESSURE RATIO	-----
CR		TABULAR DATA: FAN FLOW RATE (REVERSE) VS PRESSURE RATIO	-----
P	2	OUTLET PRESSURE	PSIA
W	1	INLET FLOW RATE	LB/MIN
T	1	INLET TEMPERATURE	DEGR
PRR		PRESSURE RATIO BELOW WHICH TRANSITION FROM STALLED TO NORMAL OPERATION OCCURS	-----
PRS		PRESSURE RATIO ABOVE WHICH TRANSITION FROM NORMAL TO STALLED OPERATION OCCURS	-----
TC		FAN TIME CONSTANT	SEC

### OUTPUT

PHYSICAL QUANTITY NAME	PORT NO.	DESCRIPTION	UNITS
T	2	OUTLET TEMPERATURE	DEGR
*WC		FAN FLOW RATE	LB/MIN
*P	1	INLET PRESSURE	PSIA

\* State Variables

References: Analysis -- Volume I, Section 3.2.2

Listing -- Volume II, Section 4.2.2

FH

### FAN WITH HYSTERESIS

EQUATIONS:

- $T2 = T1$
- $P1CAL = W1 * SQRT(T1) / WC$
- $P1 = (P1CAL - P1) / .01$
- $PR = P2 / P1$
- $WCF = CF(PR)$
- $WCR = CR(PR)$
- $CR(50) = 1 \quad WC > WCF$
- $CR(50) = -1 \quad WC < WCR$
- $CR(50) = -1 \quad PR > PRS$
- $CR(50) = 1 \quad PR < PRR$
- $WCCAL = WCF \quad CR(50) = 1$
- $WCCAL = WCR \quad CR(50) = -1$
- $WC = (WCCAL - WC) / TC$

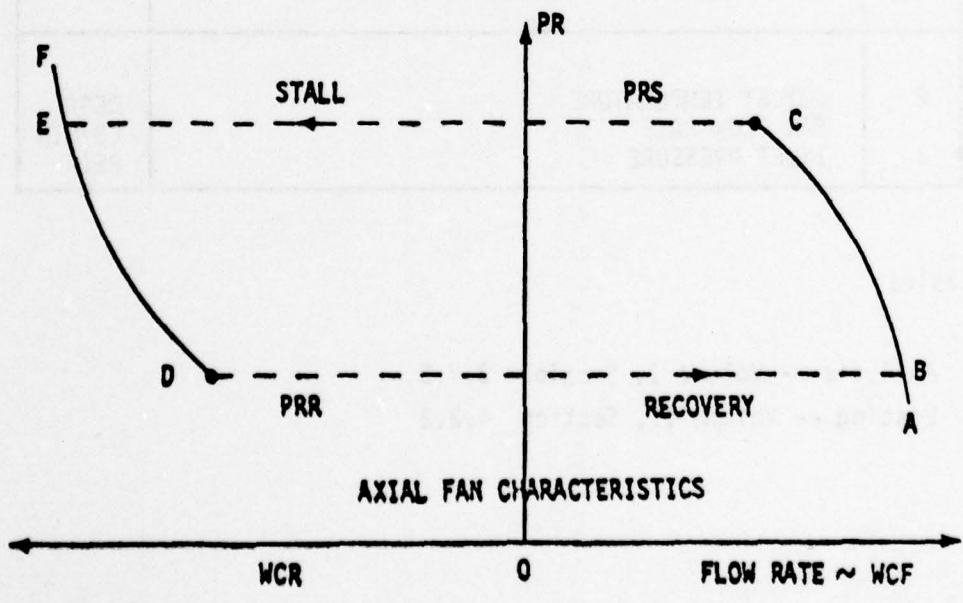

FL

AMBIENT CONDITIONS

INPUT

PHYSICAL QUANTITY NAME	PORT NO.	DESCRIPTION	UNITS
ALT		ALTITUDE	FT
AMN		MACH NO.	--
DAY		CODE DESIGNATING DAY = 1 MIL-STD-210B OPERATIONAL (1P/C RISK) HOT DAY = 2 MIL-STD-210A HOT DAY = 3 MIL-STD-210A TROPICAL DAY = 4 US STANDARD ATMOSPHERE (1962) = 5 MIL-STD-210A POLAR DAY = 6 MIL-STD-210A COLD DAY = 7 MIL-STD-210B OPERATIONAL (1P/C RISK) COLD DAY	--

OUTPUT

PHYSICAL QUANTITY NAME	PORT NO.	DESCRIPTION	UNITS
PAM		AMBIENT PRESSURE	PSIA
TAM		AMBIENT TEMPERATURE	DEGR
PRM		RAM PRESSURE (100P/C RECOVERY)	PSIA
TRM		RAM TEMPERATURE (100P/C RECOVERY)	DEGR

EQUATIONS:

$$\begin{aligned}
 PAM &= TBLU2(ALT, DAY) \\
 TAM &= TBLU2(ALT, DAY) \\
 PRM &= PAM * (1. + .2 * AMN * AMN) ** 3.5 \\
 TRM &= TAM * (1. + .2 * AMN * AMN)
 \end{aligned}$$

FOSTER MILLER INELASTIC TRUNK MODEL

FM

INPUT

TABLE NAME	TABLE DESCRIPTION	
STC **	-MISC DATA ARRAY; PARAMETERS USED IN CALCULATION OF HEAVE-PITCH-ROLL LOAD MAPS	
FAN **	-FAN DATA ARRAY; POLYNOMIAL COEFFICIENTS, FAN AIR INERTANCE, MAXIMUM STABLE PRESSURE	
ORF **	-MISC DATA ARRAY; ORIFICE AREA, NUMBER OF ORIFICE ROWS, SPACING, DIMENSIONS, X COORDINATE OF CG	
AII **	-AIRCRAFT DATA ARRAY; MOMENTS AND PRODUCTS OF INERTIA.HORIZONTAL, VERTICAL, AND LATERAL CG DISTANCES FROM CUSHION CENTER	
PRV **	-PRESSURE RELIEF VALVE DATA ARRAY; NUMBER OF VALVES, DIMENSIONS, STIFFNESS, MASS	
TRK **	-TRUNK DATA ARRAY; ATTACH POINT DIMENSIONS, TRUNK FREE HEIGHT, AND TRUNK POLYNOMIAL COEFFICIENTS	
XXX **	-MISC COEFFICIENT ARRAY; VARIOUS DISCHARGE COEFFICIENTS, POLYTROPIC CONSTANT (DEFAULT VALUES FOR THIS TABLE ARE PROVIDED IN SUBROUTINE PARAMS)	
YYY **	-MISC DATA ARRAY; GROUND EFFECT COEFFICIENT, PRV DAMPING RATIO, COEFFICIENT OF FRICTION, TRUNK DAMPING CONSTANT, BRAKING DECELERATION (DEFAULT VALUES FOR THIS TABLE ARE PROVIDED IN SUBROUTINE PARAMS)	
	<p>**Due to limitations in the number of Fortran variables permitted in a subroutine argument list, some of the input variables for this component must be input as arguments of an EASY table. See page 75 for a definition of each table argument.</p>	

FOSTER MILLER  
INELASTIC TRUNK MODEL

FM

INPUTS

QUANTITY NAME	DESCRIPTION	UNITS
FMM	NUMBER OF STRAIGHT TRUNK SEGMENTS PER QUARTER OF TRUNK PERIPHERY	----
FNN	NUMBER OF CURVED TRUNK SEGMENTS PER QUARTER OF TRUNK PERIPHERY	----
VLX	AIRCRAFT FORWARD VELOCITY	FT/SEC
PAT	AMBIENT PRESSURE	PSFG
TAM	AMBIENT TEMPERATURE	DEGF
AMS	AIRCRAFT WEIGHT	LBS
VCD	CUSHION DEAD VOLUME	CU FT
VPL	PLENUM VOLUME	CU FT
VFN	FAN VOLUME	CU FT
AAT	FAN INLET ORIFICE AREA	SQ FT
APA	PLENUM-TO-ATMOSPHERE ORIFICE AREA	SQ FT
APT	PLENUM-TO-TRUNK ORIFICE AREA	SQ FT
APC	PLENUM-TO-CUSHION ORIFICE AREA	SQ FT
FMC	COMPONENT MODE OPTION LE.O. FOSTER MILLER MODE - DUPLICATES FOSTER MILLER/NASA ACLS PROGRAM, GT.O. EASY MODE - ENABLES EASY ANALYSES WHICH REQUIRE LINEARIZATION (STEADY STATE, LINEAR ANALYSIS)	
FII	STATIC/DYNAMIC OPTION PARAMETER = -1 DYNAMIC MODE ONLY. INITIAL CONDITIONS FOR STATES 1,2,3 AND 13 ARE ESTIMATED BY THE PROGRAM. REMAINING INIT CONDS MUST BE INPUT BY USER. = 0 DYNAMIC MODE ONLY. ALL INITIAL CONDS MUST BE INPUT BY USER. = 1 STATIC LOAD MAPS + DYNAMIC MODE. INIT CONDS FOR STATES 1,2,3 AND 13 ARE ESTIMATED BY THE PROGRAM. REMAINING MUST BE INPUT BY USER. = 2 STATIC LOAD MAPS + DYNAMIC MODE. ALL INIT CONDS MUST BE INPUT BY USER. = 3 STATIC LOAD MAPS + EQUILIBRIUM CALCS + DYNAMIC MODE. INIT CONDS FOR STATES 1,2, 3 AND 13 ARE SET TO EQUILIBRIUM CALCS. USER MUST INPUT OTHERS. = 4 STATIC LOAD MAPS + EQUILIBRIUM CALCS + DYNAMIC MODE. INIT CONDS FOR STATES 1,2, 3, AND 13 ARE ESTIMATED BY PROGRAM. USER MUST INPUT OTHERS. = 5 STATIC LOAD MAPS + EQUILIBRIUM CALCS + DYNAMIC MODE. USER MUST INPUT ALL INIT CONDITIONS.	

FOSTER MILLER  
INELASTIC TRUNK MODEL  
OUTPUTS

FM

QUANTITY NAME	DESCRIPTION	UNITS
*PLM	PLENUM PRESSURE - STATE # 1	PSFG
*PCH	CUSHION PRESSURE - STATE # 2	PSFG
*PTK	TRUNK PRESSURE - STATE # 3	PSFG
*SNK	VEHICLE CG VERTICAL VELOCITY - STATE # 4	FT/SEC
*YCG	VEHICLE CG VERTICAL DISPLACEMENT - STATE # 5	FT
*DPH	VEHICLE PITCH RATE - STATE # 6	RAD/SEC
*DTH	VEHICLE ROLL RATE - STATE # 7	"
*THE	ROLL ANGLE - STATE # 8	RADIANS
*PHI	PITCH ANGLE - STATE # 9	"
*SIE	YAW ANGLE - STATE # 10	"
*XV	DISPLACEMENT OF PRESSURE RELIEF VALVE - STATE #11	FT
*VV	VELOCITY OF PRESSURE RELIEF VALVE - STATE # 12	FT/SEC
*QFX	FAN AIR FLOW RATE - STATE # 13	CFS
CPT	CUMULATIVE CPU TIME	SEC

\* STATE VARIABLES

## USER GUIDELINES FOR FOSTER MILLER TRUNK MODEL

Input Parameter FMC - Component mode option.

1. Foster Miller mode (FMC.LE.0.)

In this mode, the program will duplicate the Foster Miller/NASA ACLS Program. The EASY command SIMULATE will initiate the analysis.

If the dynamic portion of the program is to be executed, the user should specify INT MODE=7.

No EASY analytical command other than SIMULATE should be used in this mode.

2. EASY Mode (FMC.GT.0.)

In this mode, EASY analytical commands such as STEADY STATE and LINEAR ANALYSIS, which require model linearization may be used.

If non-linear simulation (SIMULATE) is desired, the user should specify INT MODE=7.

NOTE: Results of LINEAR ANALYSIS may be erroneous if the XIC state vector is not a steady state operating point.

### FM Tables

User information for the input of data via FM tables is contained in the following pages. Descriptions for the following tables are listed in alphabetical order.

AII	STC
FAN	TRK
ORF	XXX
PRV	YYY

FM

TABLE NAME: AII

CARD IMAGES FOR ANALYSIS FILE

TABLE=AIIFM=5

AIX, AIZ, AIXY, AIYZ, AIZX

CC, GG, FF, PHA, HDC

} input numeric values in order shown

NOMENCLATURE

- AIX - aircraft roll inertia about CG (slug ft<sup>2</sup>)
- AIZ - aircraft pitch inertia about CG (slug ft<sup>2</sup>)
- AIXY - aircraft product of inertia,  $I_{XY}$  (slug ft<sup>2</sup>)
- AIYZ - aircraft product of inertia,  $I_{YZ}$  (slug ft<sup>2</sup>)
- AIZX - aircraft product of inertia,  $I_{ZX}$  (slug ft<sup>2</sup>)
- CC - horizontal distance of CG from geometric center of cushion (feet). Positive if CG in front of geometric center.
- GG - vertical distance of CG from geometric center of cushion (feet). Positive if CG above the geometric center.
- FF - lateral distance of CG from geometric center of cushion (feet). Positive if CG on right side of geometric center.
- PHA - heave drag area (sq ft)
- HDC - heave drag coefficient

FM

TABLE NAME: FAN

CARD IMAGES FOR ANALYSIS FILE

TABLE=FANFM=6

G0, G1, G2, G3, G4, QP1

AL0, AL1, AL2, AL3, AL4, AIFAN

} input numeric values in order shown

NOMENCLATURE

G0, G1, G2, G3, G4 coefficients of fan curve polynomial (dynamic):

$$P = G0 + G1*Q + G2*Q*Q + G3*Q*Q*Q + G4*Q*Q*Q*Q$$

AL0, AL1, AL2, AL3, AL4 coefficients of fan curve polynomial (static):

$$Q = AL0 + AL1*P + AL2*P*P + AL3*P*P*P + AL4*P*P*P*P$$

QP1 - maximum stable fan pressure (PSF)

AIFAN - fan air inertance (lbs-sec\*sec/ft<sup>5</sup>)

Q - fan flow rate (CFS)

P - fan pressure (PSF)

FM

TABLE NAME: ORF

CARD IMAGES FOR ANALYSIS FILE

TABLE=ORFFM=4

NR, NH, AH, SH

LP, LS, D, XCG

} input numeric values in order shown

NOMENCLATURE

- NR - number of rows of trunk orifices
- NH - number of trunk orifices per row
- AH - area of trunk orifice (sq in)
- SH - trunk orifice row spacing (ft)
- LP - peripheral distance from inner trunk attachment to first row (ft) of orifices
- LS - straight section length of cushion (ft)
- D - distance between trunk attachment (ft)
- XCG - x coordinate of CG in the inertial (ft) frame

FM

TABLE NAME: PRV

CARD IMAGES FOR ANALYSIS FILE

TABLE=PRVFM=3

NPRV, DPRV, PPLMB, XA, AKPRV, AMPRV      input numeric values in  
order shown

NOMENCLATURE

- NPRV    -    number of pressure relief valves
- DPRV    -    diameter of pressure relief valves (inch)
- PPLMB    -    actuation pressure (PSIG) of pressure relief valve
- XA        -    stroke of relief valve motion (inch) between stops
- AKPRV    -    stiffness of pressure relief (lb/inch) valve
- AMPRV    -    mass of pressure relief valve (lbs)

NOTE: The user need not input this table if no relief valves are desired. When no valves are present, integrator controls for states XV FM and VV FM must be set to zero.

TABLE NAME: STC

CARD IMAGES FOR ANALYSIS FILE

TABLE=STCFM=5

YSTRT, YSTOP, PHIYC, THEYC, PSTRT  
 PSTOP, YCPHI, TSTRT, TSTOP, YCTHE } input numeric values in order shown

NOMENCLATURE

- YSTRT - upper bound of the heave load map (ft)
- YSTOP - lower bound of the heave load map (ft)
- PHIYC - fixed pitch angle in the heave load map (degrees)
- THEYC - fixed roll angle for the heave load map (degrees)
- PSTRT - lower bound for the pitch load map (degrees)
- PSTOP - 1) upper bound for the pitch load map (degrees)  
 2) last value of PFAN in iteration 3 in subroutine STATIC
- YCPHI - fixed CG elevation for the pitch load map
- TSTRT - lower bound of the roll load map (degrees)
- TSTOP - upper bound of the roll load map (degrees)
- YCTHE - fixed CG elevation for the roll load map (ft)

TABLE NAME: TRK

CARD IMAGES FOR ANALYSIS FILE

TABLE=TRKFM=4

A, B, L, HYI,

AH0, AH1, AH2, AH3

} input numeric values in order shown

NOMENCLATURE

A - horizontal distance between inner and outer trunk attachment points (ft)

B - vertical distance between trunk attachment points (ft)

L - peripheral trunk length (ft)

HYI - height of trunk cross section for zero cushion pressure (ft)

AH0, AH1, AH2, AH3 - coefficients of trunk shape characteristic polynomial

$$Z = AH0 + AH1*X + AH2*X*X + AH3*X*X*X$$

$$Z = HY/HYI, \quad X = PCH/PTK$$

FM

TABLE NAME: XXX\*

CARD IMAGES FOR ANALYSIS FILE

TABLE=XXXFM=4

CKK, CPA, CAF, CPC

CPT, CTC, CTA, CGAP

} input numeric values in order shown

NOMENCLATURE

- CKK - polytropic expansion constant
- CPA - discharge coefficient of plenum-to-atmosphere orifice
- CAF - discharge coefficient of atmosphere-to-fan orifice
- CPC - discharge coefficient of plenum-to-cushion orifice
- CPT - discharge coefficient of plenum-to-trunk orifice
- CTC - discharge coefficient of trunk-to-cushion orifice
- CTA - discharge coefficient of trunk-to-atmosphere orifice
- CGAP - discharge coefficient of clearance gap

\*If this table is not input, the following default values are assigned:

CKK = 1.4	CPT = 0.9
CPA = 0.6	CTC = 0.76
CAF = 1.0	CTA = 0.76
CPC = 0.6	CGAP = 1.0

FM

TABLE NAME: YYY\*

CARD IMAGES FOR ANALYSIS FILE

TABLE=YYYFM=4

GEC, ZEPRV, U, DECCL

DAMPL, QP2, SLOPE, CVENT

} input numeric values in order shown

NOMENCLATURE

GEC - ground effect coefficient

ZEPRV - damping ratio of pressure relief valve

U - coefficient of friction between trunk and ground

DECCL - braking deceleration (ft/sec<sup>2</sup>)

DAMPL - trunk damping constant (lbs-sec/ft<sup>2</sup>)

QP2 - minimum fan stall flow (CFS)

SLOPE - fan negative flow slope (PSF/CFS)

CVENT - discharge coefficient of pressure relief valve

\*If this table is not input, the following default values are assigned:

GEC	=	0.2	DAMPL	=	3.2
ZEPRV	=	0.15	QP2	=	5.0
U	=	0.5	SLOPE	=	10.0
DECCL	=	0.	CVENT	=	0.7

# FN

## INLET FAN

### INPUT

PHYSICAL QUANTITY NAME	PORT NO.	DESCRIPTION	UNITS
FAN		TABULAR DATA: FAN FLOW RATE VS PRESSURE RATIO (P2/PIN) AND FAN RPM.	LB/SEC
STA		TABULAR DATA: FAN STALL LINE VS PRESSURE RATIO (P2/PIN).	
P	2	OUTLET PRESSURE	PSIA
PAM		AMBIENT AIR PRESSURE	PSIA
TAM		AMBIENT AIR TEMPERATURE	DEGR
PRM		INLET RAM PRESSURE 100 P/C RECOVERY (DEFAULT = PAM)	PSIA
TRM		INLET RAM TEMPERATURE 100 P/C RECOVERY (DEFAULT = TAM)	DEGR
NUI		INLET RAM EFFICIENCY (DEFAULT = 0.0)	----
NUF		FAN EFFICIENCY (DEFAULT = 1.0)	----
COR		LOGICAL VARIABLE TO ELIMINATE THE FAN FLOW RATE CORRECTIONS (i.e. TIN/TO AND PIN/PO) WHEN SET TO 0.0. (DEFAULT = 0.0)	
RPM		FAN SPEED	RPM

### OUTPUT

PHYSICAL QUANTITY NAME	PORT NO.	DESCRIPTION	UNITS
T	2	OUTLET TEMPERATURE	DEGR
W	2	FAN FLOW RATE	LB/SEC
PIN		INLET PRESSURE	PSIA
TIN		INLET TEMPERATURE	DEGR
PR		PRESSURE RATIO (P2/PIN)	----

FN

INLET FAN

EQUATIONS:

```
PIN = (PRM-PAM)*NUI + PAM
TIN = (TRM-TAM)*NUI + TAM
PR = P2/PIN
CP = SHCP(TIN, 0.0)
GAMMA = 1. + R/(778.*CP-R)
G1 = (GAMMA - .1)/GAMMA
T2 = TIN + (TIN/NUF)*(PR**G1-1.)
WIDEAL = TBLU2(PR, RPM)
DELTA = PIN/14.697
THETA = TIN/518.7
RATIO = DELTA/SQRT (THETA)
IF(COR.EQ. 0.0) RATIO = 1.0
W2 = WIDEAL*RATIO
WSTALL = TBLU1(PR)
IF(WIDEAL.LT. WSTALL) PRINT: FAN IS OPERATING
IN THE STALL REGION.
```

FAN (REVERSE FLOW CAPABILITY)

FR

INPUT

PHYSICAL QUANTITY NAME	PORT NO.	DESCRIPTION	UNITS
PR		TABULAR DATA: PRESSURE RATIO (P2/P1) VS WCO AND N/SQRT(T)	---
ET		TABULAR DATA: EFFICIENCY VS WCO AND N/SQRT(T)	---
T	1	INLET TEMPERATURE	DEGR
W	1	INLET FLOW RATE	LB/MIN
P	2	OUTLET PRESSURE	PSIA
EN		FAN SPEED	RPM/1000
UA		OVERALL CONDUCTANCE	BTU/HR/DEGR
TAM		EFFECTIVE LOCAL AMBIENT TEMPERATURE	DEGR

OUTPUT

PHYSICAL QUANTITY NAME	PORT NO.	DESCRIPTION	UNITS
T	2	OUTLET TEMPERATURE	DEGR
W	2	OUTLET FLOW	LB/MIN
*P	1	INLET PRESSURE	PSIA
WCO		FAN CORRECTED FLOW	---
WKC		FAN WORK INPUT	FT/LB/SEC
ETC		FAN EFFICIENCY	---

Maximum Table Dimensions: 14 x 14

References: Analysis -- Volume I, Section 3.2.2  
 Listing -- Volume II, Section 4.2.3

\* State Variable

AD-A081 160

BOEING AEROSPACE CO SEATTLE WA BOEING MILITARY AIRPL--ETC F/G 9/2  
EASY-ACIS DYNAMIC ANALYSIS. USER'S MANUAL.(U)

SEP 79 M K WAHI, G S DULEBA, P R PERKINS

F33615-77-C-3054

UNCLASSIFIED

AFFDL-TR-79-3106

NL

2 OF 4

AD  
A081160

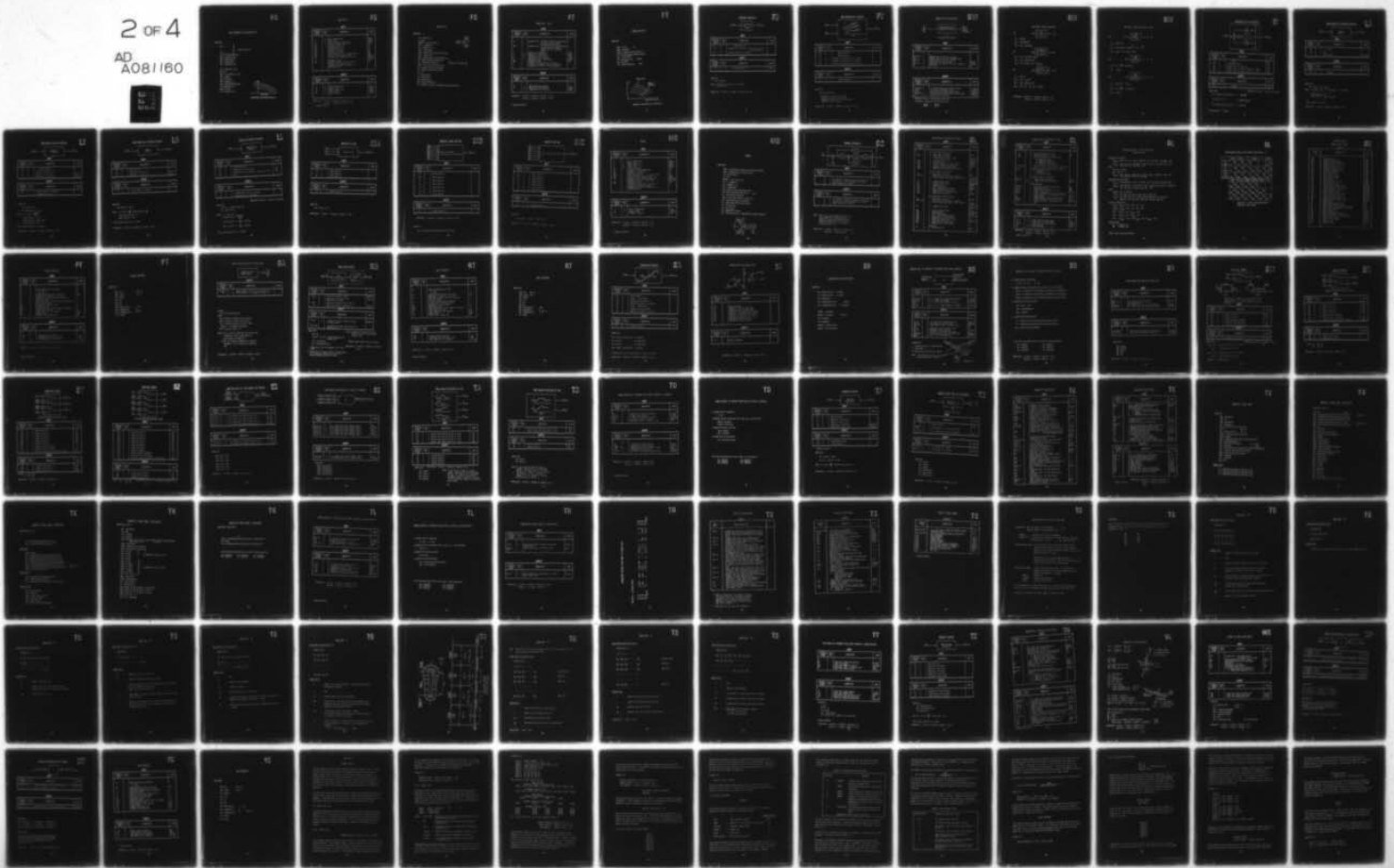

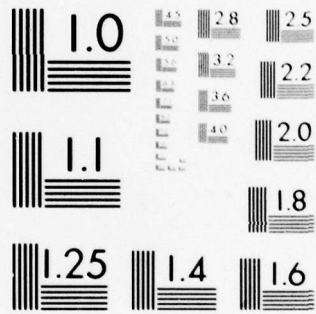

MICROCOPY RESOLUTION TEST CHART  
NATIONAL BUREAU OF STANDARDS-1963-A

## FAN (REVERSE FLOW CAPABILITY)

## EQUATIONS:

$$\left. \begin{aligned} CP &= \dots\dots\dots \\ T1 &= \dots\dots\dots \end{aligned} \right\} \text{ same as Duct DU}$$

$$ENC = 1000.*EN/SQRT(T1)$$

$$WCO = W1*SQRT(T1)/P1$$

$$PR = PRTAB(WCO,ENC)$$

$$ETC = ET(WCO,ENC)$$

$$ETC = AMAX1(ETC,.01)$$

$$ETC = AMIN1(ETC,-.01)$$

$$W2 = W1$$

$$DELT = T1*(PR**G1-1.)/ETC$$

$$T2 = T1+DELT$$

$$TM = (T1+T2)/2.$$

$$CPM = SHCP(TM,0.)$$

$$WKC = W2*CPM*DELT*778./60.$$

$$PR = AMAX1(PR,.01)$$

$$P1CAL = P2/PR$$

$$P1 = (P1CAL-P1)/.01$$

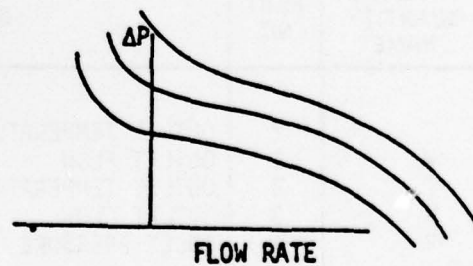

CENTRIFUGAL FAN CHARACTERISTICS

# FLOW SPLIT

# FS

## INPUT

PHYSICAL QUANTITY NAME	PORT NO.	DESCRIPTION	UNITS
T	1	INLET TEMPERATURE	DEGR
W	1	INLET FLOW	LB/MIN
P	2	OUTLET PRESSURE (PORT NO 2)	PSIA
P	3	OUTLET PRESSURE (PORT NO 3)	PSIA
AK2		K FACTOR (PORT NO 2)	---
D2		DIAMETER (PORT NO 2)	IN
AK3		K FACTOR (PORT NO 3)	---
D3		DIAMETER (PORT NO 3)	IN
DHY		HYDRAULIC DIAMETER	IN
AHT		HEAT TRANSFER AREA TO CALCULATE UA	FT2
TAM		EFFECTIVE LOCAL AMBIENT TEMP	DEGR
HO		EXTERNAL HEAT TRANSFER COEFFICIENT	BTU/FT2 HR DEGR
VOL		INTERNAL VOLUME	FT3
FC		FREQUENCY CONTROL ON P1. (FC.GE.1.) A VALUE OF FC GREATER THAN 1. DECREASES FREQUENCY RESPONSE OF P1 CORRESPONDINGLY	---

## OUTPUT

PHYSICAL QUANTITY NAME	PORT NO.	DESCRIPTION	UNITS
T	2	OUTLET TEMPERATURE	DEGR
W	2	OUTLET FLOW	LB/MIN
T	3	OUTLET TEMPERATURE	DEGR
W	3	OUTLET FLOW	LB/MIN
*P	1	INLET PRESSURE	PSIA

References: Analysis -- Volume I, Section 3.1.2

Listing -- Volume II, Section 4.1.2

\* State Variables

## FLOW SPLIT

### EQUATIONS:

$$CP = SHCP(T1, 0.)$$

$$R = 53.3$$

$$GAMMA = 1. + R / (778. * CP - R)$$

$$G1 = 1. / (GAMMA - 1.)$$

$$G2 = (GAMMA - 1.) / 2.$$

$$CA2 = .7854 * D2 * D2$$

$$CALL \text{ FNFLOW}(P1, P2, T1, CA2, AK2, FN, W2)$$

$$CA3 = .7854 * D3 * D3$$

$$CALL \text{ FNFLOW}(P1, P3, T1, CA3, AK3, FN, W3)$$

$$\bar{W} = (ABS(W1) + ABS(W2) + ABS(W3)) / 3.$$

$$AL = 183.35 * AHT / (DHY * DHY)$$

$$HINT = HI(1, T1, T1, \bar{W}, 0., DHY, AL, 0.)$$

$$UA = AHT * HINT * HO / (60. * (HINT + HO))$$

$$T2 = TAM + (T1 - TAM) / \exp(UA / CP * \bar{W})$$

$$T3 = T2$$

$$\bar{T} = (T1 + T2 + T3) / 3.$$

$$\bar{P} = (P1 + P2 + P3) / 3.$$

$$\bar{CA} = (CA2 + CA3) / 2.$$

$$AM = AMACH(\bar{P}, \bar{T}, \bar{CA}, \bar{W}, 0.)$$

$$P1 = R * \bar{T} * (W1 - W2 - W3) * (1. + G2 * AM * AM) ** G1 / (8640. * VOL * FC)$$

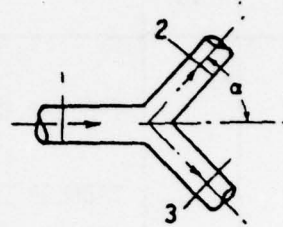

$$\left\{ 183.35 = 144 / (\pi / 4) \right\}$$

FT

TURBO FAN - ACLS

INPUT

PHYSICAL QUANTITY NAME	PORT NO.	DESCRIPTION	UNITS
WC		TABULAR DATA: CORRECTED TURBINE FLOW (LB/SEC) VS DRIVE (BLEED) CUSHION (OR TRUNK) PRESSURE RATIO	---
TØT		TABULAR DATA: TOTAL FLOW FROM TURBOFAN (LB/SEC) VS CUSHION/TRUNK PRESSURE (PSFG) AND DRIVE PRESSURE (PSIA)	---
P	2	AMBIENT AIR PRESSURE	PSIA
T	2	AMBIENT AIR TEMPERATURE	DEGR
P	3	PRESSURE OF FAN AIR EXIT	PSIA
W	1	DRIVE/BLEED AIR FLOW RATE	LB/MIN
T	1	DRIVER/BLEED AIR TEMPERATURE	DEGR
VØL		INTERNAL VOLUME	FT <sup>3</sup>
FC		FREQUENCY CONTROL ON P1. (FC.GE.1.) A VALUE OF FC GREATER THAN 1. DECREASES FREQUENCY RESPONSE OF P1 CORRESPONDINGLY	---

OUTPUT

PHYSICAL QUANTITY NAME	PORT NO.	DESCRIPTION	UNITS
*P	1	DRIVE/BLEED AIR PRESSURE	PSIA
W	3	TOTAL FLOW FROM TURBOFAN	LB/MIN
T	3	TEMPERATURE OF FAN AIR EXIT	DEGR

References: Analysis -- Volume I, Section 3.2.2.3  
Listing -- Volume II, Section 4.2.4

\* State Variables

FT

### TURBO FAN-ACLS

#### EQUATIONS:

$$\begin{aligned} \text{PRAT} &= P1/P3 && \geq 1. \\ \text{WCOR} &= \text{WC}(\text{PRAT}) \\ \text{WICAL} &= 60 * \text{WCOR} * 1.55 * P1 / \text{SQRT}(T1) \\ P1 &= R * T1 * (W1 - \text{WICAL}) / (8640. * \text{FC} * \text{VOL}) \\ \text{PSF} &= (P3 - P2) * 144 \\ W3 &= 60 * \text{TOT}(\text{PSF}, P1) && \geq \text{WICAL} \\ W2 &= W3 - \text{WICAL} \\ T3 &= (W1 * T1 + W2 * T2) / W3 && \geq 400. \end{aligned}$$

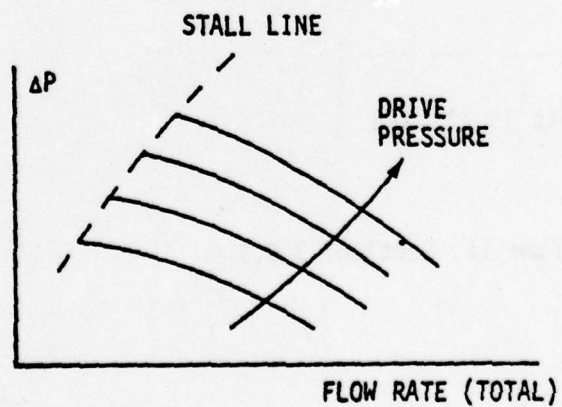

TURBOFAN CHARACTERISTICS (UNSTALLED)

## FUNCTION GENERATOR

FU

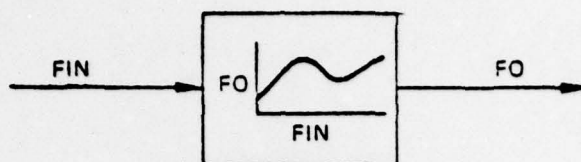

### INPUT

PHYSICAL QUANTITY NAME	PORT NO.	DESCRIPTION	UNITS
FIN		Input quantity	
AN		Degree of interpolation (AN < 0 prevents extrapolation)	
FTA		Tabular values of function	

### OUTPUT

PHYSICAL QUANTITY NAME	PORT NO.	DESCRIPTION	UNITS
FO		Output quantity	Any

**EQUATION:**

$$FO = FTA(FIN)$$

**NOTE:** A maximum of 18 points is allowed in the table.

**References:** Listing -- Volume II, Section 3.5.9

## TWO DIMENSIONAL FUNCTION

**FV**

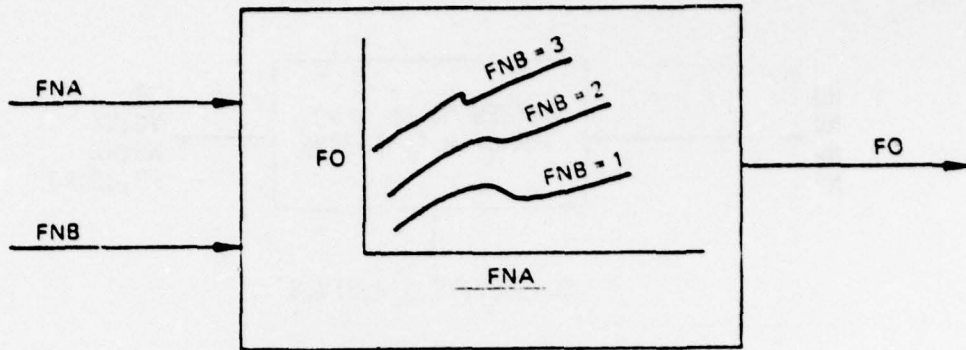

### INPUT

PHYSICAL QUANTITY NAME	PORT NO.	DESCRIPTION	UNITS
FNA		Input quantity	
FNB		Input quantity	
AN		Degree of interpolation for FNA *	
BN		Degree of interpolation for FNB *	
FTA		Table of functional relationships	

### OUTPUT

PHYSICAL QUANTITY NAME	PORT NO.	DESCRIPTION	UNITS
FO		Output quantity	

EQUATION:

$$FO = FTA(FNA, FNB)$$

\* A negative value for AN or BN prevents extrapolation beyond the table boundaries, and the nearest endpoint value is used.

References: Listing -- Volume II, Section 3.5.14

# RANDOM WIND GUST MODEL

# GW

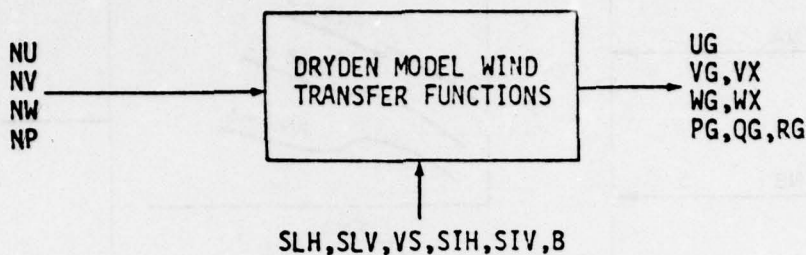

## INPUT

PHYSICAL QUANTITY NAME	PORT NO.	DESCRIPTION	UNITS
NU, NV, NW NP SLH, SLV VS SIH, SIV B	1	RANDOM NOISE INPUTS FOR UW, VW, WW RANDOM NOISE INPUT FOR PW ANGULAR RATE HORIZONTAL AND VERTICAL SCALES* STEADY STATE AIRSPEED INPUT HORIZONTAL AND VERTICAL RMS GUST INTENSITY* WING SPAN	FT FT/SEC FT/SEC FT

## OUTPUT

PHYSICAL QUANTITY NAME	PORT NO.	DESCRIPTION	UNITS
UG, VG, WG VX, WX QX, RX PG, QG, RG VS	2	X, Y, Z BODY AXIS WIND VELOCITY STATES Y, Z AXIS INTERMEDIATE STATES BODY AXIS WIND ANGULAR RATE STATES X, Y, Z BODY AXIS WIND ANGULAR RATE OUTPUTS STEADY STATE AIRSPEED	FT/SEC FT/SEC <sup>2</sup> DEG/SEC DEG/SEC FT/SEC

\*Default values: SLH=SLV=1750, SIH=SIV=0.

In general, choose SIH and SIV such that

$$\frac{(SIH)^2}{SLH} = \frac{(SIV)^2}{SLV}$$

## WIND MODEL TRANSFER EQUATIONS

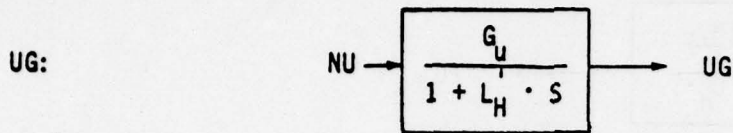

$$L_H' = SLH/VS$$

$$G_U = SIH(2L_H'/\pi)^{1/2}$$

$$\dot{U}G = (G_U \cdot \text{NU} - \text{UG})/L_H'$$

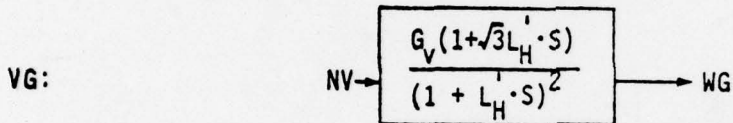

$$G_V = SIH \cdot (L_H'/\pi)^{1/2} = G_U/\sqrt{2}$$

$$\dot{V}X = (G_V \cdot \text{NV} - \text{VG})/(L_H')^2$$

$$\dot{V}G = \text{VX} + (\sqrt{3} \cdot G_V \cdot \text{NV} - 2 \cdot \text{VG})/L_H'$$

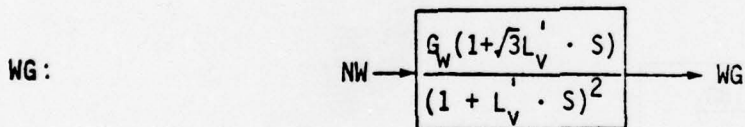

$$L_V' = SLV/VS$$

$$G_W = SIV \cdot (L_V'/\pi)^{1/2}$$

$$\dot{W}X = (G_W \cdot \text{NW} - \text{WG})/(L_V')^2$$

$$\dot{W}G = \text{WX} + (\sqrt{3} \cdot G_W \cdot \text{NW} - 2 \cdot \text{WG})/L_V'$$

References: Analysis -- Volume I, Section 2.5.1  
 Listing -- Volume II, Section 4.5.1

## WIND MODEL TRANSFER EQUATIONS (CONT.)

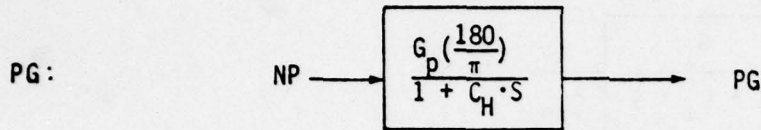

$$C_H = 4B / (\pi \cdot VS)$$

$$G_p = SIV \cdot (0.8(\pi \cdot SLV / (4B)))^{\frac{1}{3}} / (SLV \cdot VS)^{\frac{1}{2}}$$

$$\dot{P}G = ((G_p \cdot NP - PG) / C_H) \cdot 180 / \pi$$

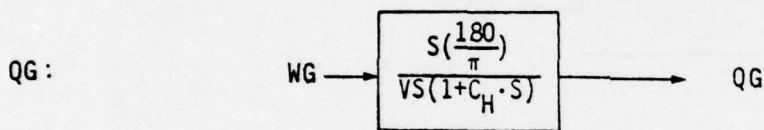

$$QG = QX + \frac{180}{\pi} \cdot WG / (VS \cdot C_H)$$

$$\dot{Q}X = -QG / C_H$$

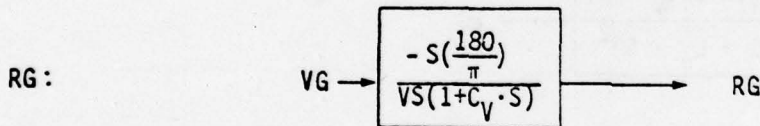

$$C_V = 3B / (\pi \cdot VS) = .75 \cdot C_H$$

$$RG = RX - \frac{180}{\pi} \cdot VG / (VS \cdot C_V)$$

$$\dot{R}X = -RG / C_V$$

## INTEGRATOR WITH SATURATION

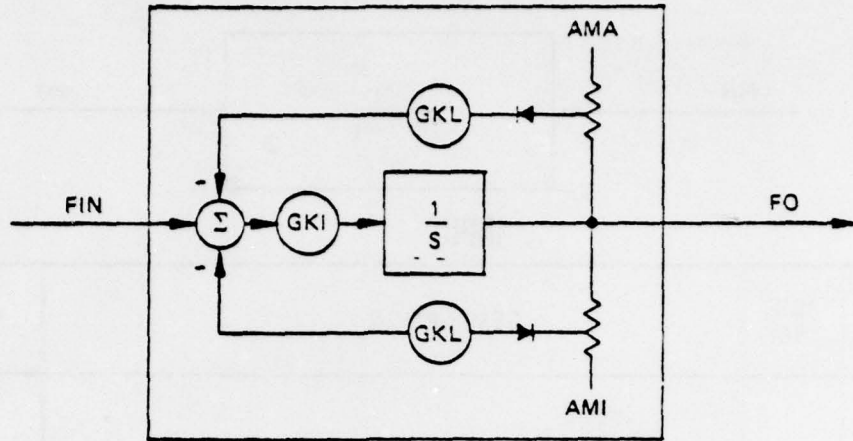

### INPUT

PHYSICAL QUANTITY NAME	PORT NO.	DESCRIPTION	UNITS
FIN		Input	Any
GKI		Integration gain	Any
GKL		Saturation limiter gain	Any
AMA		Upper limit of output (Default = $10^{36}$ )	Any
AMI		Lower limit of output (Default = $-10^{36}$ )	Any

### OUTPUT

PHYSICAL QUANTITY NAME	PORT NO.	DESCRIPTION	UNITS
*FO		Output	Any

EQUATIONS:

Reference Listing -- Volume II, Section

$$FO = GKI[FIN - GKL(FO - AMA)] \quad \text{if } FO > AMA$$

$$\dot{FO} = GKI * FIN \quad \text{if } AMI \leq FO \leq AMA$$

$$\dot{FO} = GKI[FIN - GKL(FO - AMI)] \quad \text{if } FO < AMI$$

\*This output is a state.

# FIRST ORDER LAG TRANSFER FUNCTION

LA

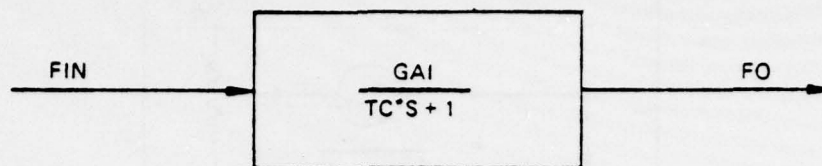

## INPUT

PHYSICAL QUANTITY NAME	PORT NO.	DESCRIPTION	UNITS
FIN		Input	
GAI		Gain	
TC		Time constant	seconds

## OUTPUT

PHYSICAL QUANTITY NAME	PORT NO.	DESCRIPTION	UNITS
* FO		Output	

### EQUATIONS:

$$FO = (GAI * FIN - FO) / TC$$

NOTE: d.c. gain = GAI time constant = TC, seconds.

infinite freq. gain = 0  
 pole location =  $\frac{1}{TC}$  rad/sec.

\* This output is a state.

Reference: Listing -- Volume II, Section 3.4.1

# FIRST ORDER LEAD-LAG FUNCTION

LE

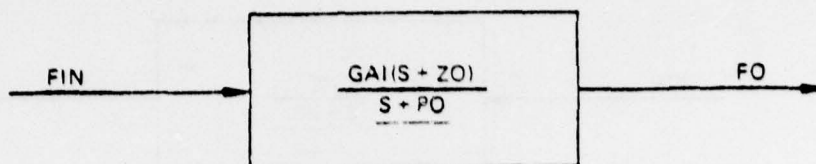

## INPUT

PHYSICAL QUANTITY NAME	PORT NO.	DESCRIPTION	UNITS
FIN		Input quantity	
GAI		Infinite frequency gain	
ZO		Numerator coefficient	rad/sec
PO		Denominator coefficient	rad/sec

## OUTPUT

PHYSICAL QUANTITY NAME	PORT NO.	DESCRIPTION	UNITS
FO		Output quantity - variable	
*X1		Intermediate quantity -	

### EQUATIONS:

$$FO = GAI \cdot FIN + X1$$

$$s \cdot X1 = GAI \cdot FIN \cdot ZO - FO \cdot PO$$

NOTE: d.c. gain =  $\frac{GAI \cdot ZO}{PO}$

zero location =  $-ZO$

infinite freq. gain = GAI

pole location =  $-PO$

\*This output quantity is a state.

References: Listing -- Volume II, Section 3.4.4

# FIRST ORDER LAG TRANSFER FUNCTION

LG

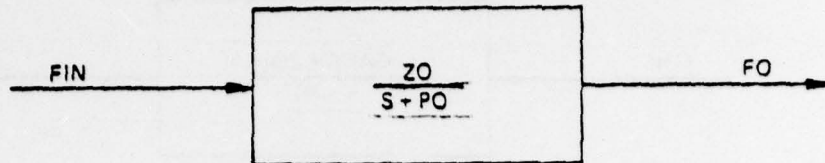

## INPUT

PHYSICAL QUANTITY NAME	PORT NO.	DESCRIPTION	UNITS
FIN		Input quantity	
ZO		Numerator coefficient	rad/sec
PO		denominator coefficient	rad/sec

## OUTPUT

PHYSICAL QUANTITY NAME	PORT NO.	DESCRIPTION	UNITS
*FO		Output quantity (State)	

### EQUATION:

$$\dot{F}_O = Z_0 \cdot F_{IN} - P_0 \cdot F_O$$

NOTE: d.c. gain =  $\frac{Z_0}{P_0}$  time constant =  $\frac{1}{P_0}$

infinite freq gain = 0

pole location =  $-P_0$

\*This output quantity is a state.

References: Listing -- Volume II, Section 3.4.2

# LEAD-LAG TRANSFER FUNCTION

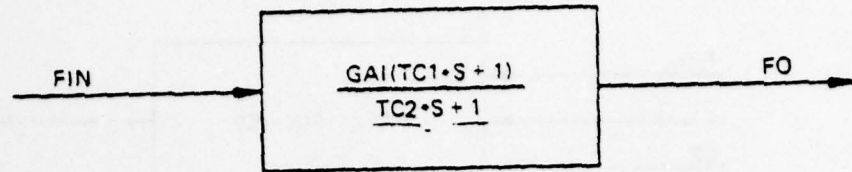

## INPUT

PHYSICAL QUANTITY NAME	PORT NO.	DESCRIPTION	UNITS
FIN		Input quantity	
TC1		Numerator time constant	sec
TC2		Denominator time constant (cannot be zero)	sec
GAI		Gain	

## OUTPUT

PHYSICAL QUANTITY NAME	PORT NO.	DESCRIPTION	UNITS
*X1		Intermediate quantity (state)	
FO		Output quantity (variable)	

Reference Listing -- Volume II, Section

### EQUATIONS:

$$FO = (X1 + FIN*TC1*GAI)/TC2$$

$$\dot{X1} = GAI(FIN-FO)$$

NOTE: d.c. gain GAI

$$\text{infinite gain} = \frac{GAI*TC1}{TC2}$$

$$\text{zero location} = -\frac{1}{TC1}, \text{ rad/sec}$$

$$\text{pole location} = -\frac{1}{TC2}, \text{ rad/sec}$$

\*This output quantity is a state.

## MULTIPLY AND ADD

# MA

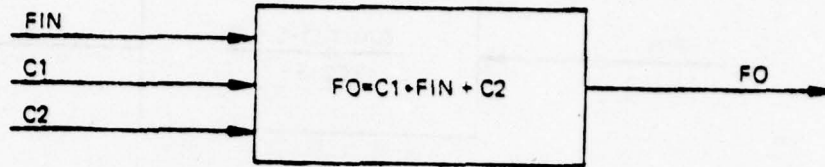

### INPUT

PHYSICAL QUANTITY NAME	PORT NO.	DESCRIPTION	UNITS
FIN		Input quantity	
C1		Input quantity	
C2		Input quantity	

### OUTPUT

PHYSICAL QUANTITY NAME	PORT NO.	DESCRIPTION	UNITS
FO		Output quantity	

EQUATION:

$$FO = C1 * FIN + C2$$

References: Listing -- Volume II, Section 3.5.8

# MULTIPLY, DIVIDE, AND ADD

MB

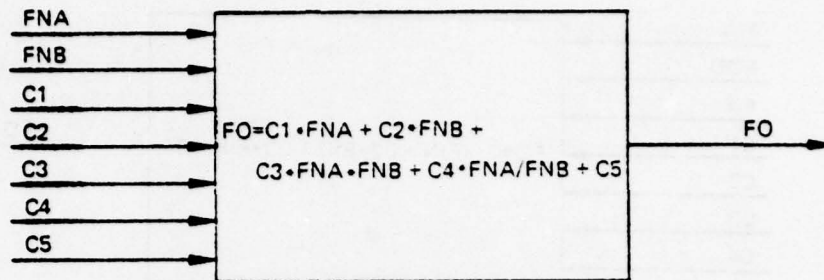

## INPUT

PHYSICAL QUANTITY NAME	PORT NO.	DESCRIPTION	UNITS
FNA		Input quantity	
FNB		Input quantity	
C1		Input quantity	
C2		Input quantity	
C3		Input quantity	
C4		Input quantity	
C5		Input quantity	

## OUTPUT

PHYSICAL QUANTITY NAME	PORT NO.	DESCRIPTION	UNITS
FO		Output quantity	

References: Listings -- Volume II, Section 3.5.13

EQUATION:

$$FO = C1 * FNA + C2 * FNB + C3 * FNA * FNB + C4 * FNA / FNB + C5$$

# MULTIPLY AND ADD

MC

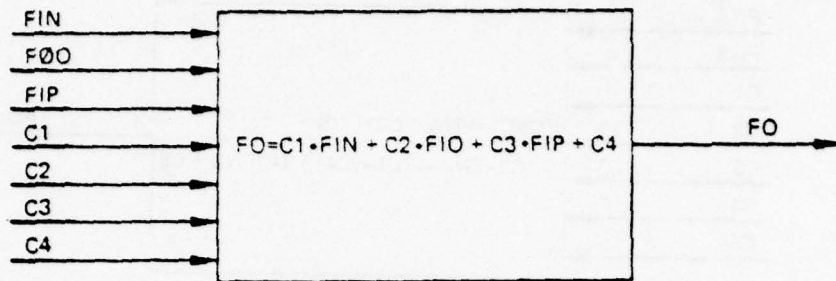

## INPUT

PHYSICAL QUANTITY NAME	PORT NO.	DESCRIPTION	UNITS
FIN		Input quantity	
FIO		Input quantity	
FIP		Input quantity	
C1		Input quantity	
C2		Input quantity	
C3		Input quantity	
C4		Input quantity	

## OUTPUT

PHYSICAL QUANTITY NAME	PORT NO.	DESCRIPTION	UNITS
FO		Output quantity	

EQUATION:

$$FO = C1 * FIN + C2 * FIO + C3 * FIP + C4$$

References: Listing -- Volume II, Section 3.5.10

## MERGE

### INPUT

PHYSICAL QUANTITY NAME	PORT NO.	DESCRIPTION	UNITS
T	1	INLET TEMPERATURE	DEGR
W	1	INLET FLOW	LB/MIN
T	2	INLET TEMPERATURE	DEGR
W	2	INLET FLOW	LB/MIN
P	3	OUTLET PRESSURE	PSIA
AK		K FACTOR FOR PRESSURE DROP	---
D3		DIAMETER CALCULATION	IN
DHY		HYDRAULIC DIAMETER	IN
AHT		HEAT TRANSFER AREA TO CALCULATE UA	FT2
TAM		EFFECTIVE LOCAL AMBIENT TEMP	DEGR
HO		EXTERNAL HEAT TRANSFER COEFFICIENT (BASED ON INTERNAL WETTED AREA)	BTU/FT2-HR DEGR
VOL		INTERNAL VOLUME	FT3
FC		FREQUENCY CONTROL ON P1. (FC.GE.1.) A VALUE OF FC GREATER THAN 1. DECREASES FREQUENCY RESPONSE OF P1 CORRESPONDINGLY	---

### OUTPUT

PHYSICAL QUANTITY NAME	PORT NO.	DESCRIPTION	UNITS
T	3	OUTLET TEMPERATURE	DEGR
W	3	OUTLET FLOW	LB/MIN
*P		INTERNAL PRESSURE	PSIA

References: Listing -- Volume II, Section 4.1.3  
 Analysis -- Volume I, Section 3.1.3

\* State Variables

## MERGE

### EQUATIONS:

$$TINB = (T1*ABS(W1)+T2*ABS(W2))/(ABS(W1)+ABS(W2))$$

$$TINB = AMAX1(AMIN1(TINB,1600.),300.)$$

$$CP = SHCP(TINB,0.)$$

$$R = 53.3$$

$$GAMMA = 1.+R/(778.*CP-R)$$

$$G1 = 1./(GAMMA-1.)$$

$$G2 = (GAMMA-1.)/2.$$

$$CA = .7854*D3*D3$$

$$CALL FNFLOW(P,P3,TINB,CA,AK, FN,W3)$$

$$\bar{W} = (ABS(W1)+ABS(W2)+ABS(W3))/3. \quad \geq .01$$

$$AL = 183.35*AHT/(DHY*DHY)$$

$$HINT = HI(1,TINB,TINB,\bar{W},0.,DHY,AL,0.)$$

$$UA = AHT*HINT*HO/(60.*(HINT+HO))$$

$$T3 = TAM+(TINB-TAM)/EXP(UA/(CP*\bar{W}))$$

$$\bar{T} = (T1+T2+T3)/3.$$

$$\bar{P} = (2.*P+P3)/3.$$

$$AM = AMACH(\bar{P},\bar{T},CA,\bar{W},0.)$$

$$P1 = R*\bar{T}*(W1+W2-W3)*(1.+G2*AM*AM)**G1/(8640.*VOL*FC)$$

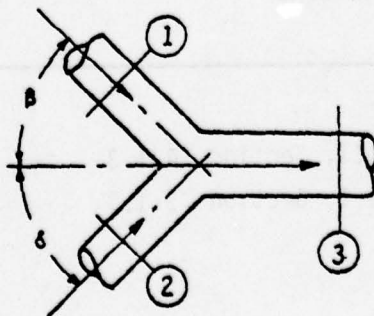

# OPTIMAL CONTROLLER

# OC

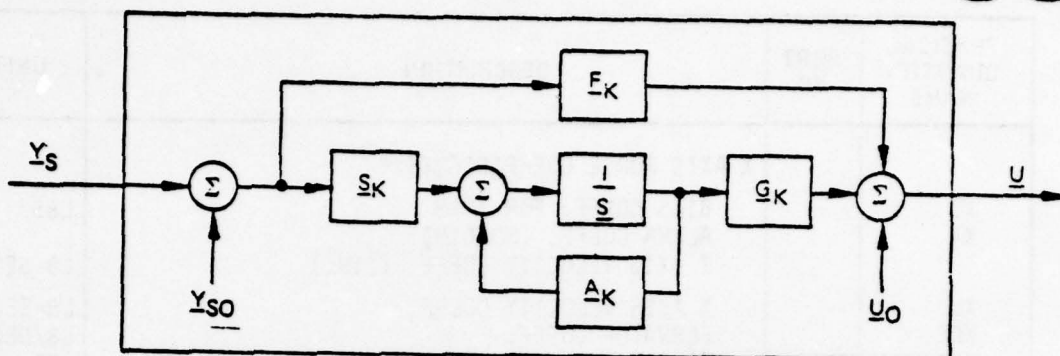

## INPUT

PHYSICAL QUANTITY NAME	PORT NO.	DESCRIPTION	UNITS
		All optimal controller inputs are defined via the O.C. INPUTS command in the EASY Model Generation Program.	

## OUTPUT

PHYSICAL QUANTITY NAME	PORT NO.	DESCRIPTION	UNITS
		All optimal controller outputs are defined via the O.C. OUTPUTS command in the EASY Model Generation Program.	

**NOTE:** Due to its very general nature, the O.C. component is specified by a special set of Model Generation and Analysis commands which all start with the letters O.C. (See pages 12, 13 and Section 4.13)

**References:** Listing -- Volume II, Section 4.7  
 Analysis -- See Reference 3

LONGITUDINAL AERODYNAMIC MODEL

OL

INPUT

PHYSICAL QUANTITY NAME	PORT NO.	DESCRIPTION	UNITS
		X AXIS FORCE COEFFICIENTS:*	
XO		BIAS COEFF. FOR TRIM	LBS
XA		ALPHA COEFF. (NONDIM)	
		Z AXIS VELOCITY COEFF. (DIM.)	LB-SEC/FT
XU		X AXIS VELOCITY COEFF.	LB-SEC/FT
XDE		ELEVATOR COEFF.	LB/DEG
XTR		TAKE OFF OR RECOVERY TRUNK COEFF.	LBS
XSP		FLIGHT + GROUND SPOILERS COEFF.	LB/DEG
XGE		GROUND EFFECT ON CXO FACTOR	---
KXB		LARGE SIDE SLIP ANGLE FACTOR FOR CXO	---
		Z AXIS FORCE COEFFICIENTS:*	
ZO		BIAS COEFF. FOR TRIM	LBS
ZA, ZAD		ALPHA AND ALPHA DOT COEFF. (NONDIM.)	
		Z AXIS VELOCITY AND ACCEL. COEFF. (DIM.)	LB-SEC/FT LB-SEC <sup>2</sup> /FT
ZO		Q ANGULAR RATE COEFF.	LB-SEC/DEG
ZU		X AXIS VELOCITY COEFF.	LB-SEC/FT
ZDE		ELEVATOR COEFF.	LB/DEG
ZTR		TRUNK COEFFICIENT	LBS
ZSP		FLT. + GROUND SPOILER COEFF.	LB/DEG
ZGE		GROUND EFFECT ON CZO FACTOR	---
KZB		LARGE SIDE SLIP FACTOR FOR CZO	---
ZDS		STABILIZER COEFFICIENT	LB/DEG
		PITCHING MOMENT COEFFICIENTS:*	
MO		BIAS COEFF. FOR TRIM	FT-LBS
MAL, MAD		ALPHA AND ALPHA DOT COEFF. (NONDIM.)	
		Z AXIS VELOCITY AND ACCEL. COEFF. (DIM.)	LB-SEC <sup>2</sup> LB-SEC <sup>2</sup>
MQ		Q ANGULAR RATE COEFF.	FT-LB-SEC /DEG
MU		X AXIS VELOCITY COEFF.	LB-SEC
MDE		ELEVATOR COEFF.	FT-LB/DEG
MTR		TRUNK COEFFICIENT	FT-LBS
MSP		FLT. + GROUND SPOILER COEFF.	FT-LB/DEG
MGE		GROUND EFFECT ON CM0 FACTOR	---
KMB		LARGE SIDE SLIP FACTOR FOR CM0	---
MDS		STABILIZER COEFFICIENT	FT-LB/DEG
MB		LARGE SIDE SLIP ANGLE COEFF.	---
KGE		GROUND EFFECT HEIGHT FACTOR	---
MA	1	CONSTANTS: RIGID BODY MASS	SLUGS

# LONGITUDINAL AERODYNAMIC MODEL INPUT

# 01

PHYSICAL QUANTITY NAME	PORT NO.	DESCRIPTION	UNITS
C XP* ID	1	MEAN AND AERODYNAMIC CHORD X AXIS DISTANCE: C.P. - C.G. INDICATOR FUNCTION FOR COEFFICIENTS  Q = BODY AXIS, DIM. 1 = BODY AXIS, NONDIM. 2 = STABILITY AXIS, DIM. 3 = STABILITY AXIS, NONDIM.	FT FT
CAL, SAL		DIRECTION COSINES FOR STABILITY, BODY AXIS	
ISW		INDICATOR FUNCTION FOR DEGREES OF FREEDOM 1 = SINGLE DØF (U) 2 = TWO DØF (W,Q) 3 = THREE DØF (U,W,Q)	
FX, FZ, TY	1 1	EXTERNAL FORCES AND MOMENTS: * X AND Z BODY AXIS FORCES Y BODY AXIS (PITCHING) MOMENT	LBS FT-LBS
STA, SPO* ELE* AL, ALP UO UP, WP		AERO-VARIABLES: STABILIZER AND SPOILER DEFLECTION ELEVATOR DEFLECTION ALPHA IN BODY AND STABILITY AXES X BODY AXIS VELOCITY X AND Z PERTURBATION VELOCITIES (NONDIM.) X AND Z STABILITY AXIS VELOCITIES (DIM.) TRUE AIRSPEED	DEG DEG DEG FT/SEC FT/SEC FT/SEC
VT QS QO, QW EU, EW		DYNAMIC PRESSURE TIMES REFERENCE AREA Y BODY AXIS ANGULAR RATE, RATE GUST X AND Z AXIS ACCEL. TERMS FOR UO, WD AXES	LBS DEG/SEC FT/SEC <sup>2</sup>

## OUTPUT

PHYSICAL QUANTITY NAME	PORT NO.	DESCRIPTION	UNITS
FX, FZ	2	X AND Z BODY AXIS FORCE SUM	LBS
TY	2	Y BODY AXIS (PITCHING) MOMENT	FT-LBS
UD, WD		X AND Z BODY AXIS ACCELERATION	FT/SEC <sup>2</sup>
MA	2	RIGID BODY MASS	SLUGS
XP	2	X AXIS DISTANCE: C.P. - C.G.	FT

References: Listing -- Volume II, Section 4.3.8

Analysis -- Volume I, Section 2.4.9

\* Default value = 0

LONGITUDINAL AERO - FORCES AND MOMENTS  
(Implicit Form)

DIMENSIONAL EQUATIONS:

$$FX_{aero} = (XO + XA \cdot WP + XU \cdot UP + XDE \cdot ELE + XTR + XSP \cdot SPO + XGE \cdot KGE) \cdot KXB$$

$$FZ_{aero} = (ZO + ZA \cdot WP + ZAD \cdot (\dot{W} + \dot{W}\dot{W}) + ZQ \cdot QO + ZU \cdot UP + ZDE \cdot ELE + ZTR + ZSP \cdot SPO + ZGE \cdot KGE + ZDS \cdot STA) \cdot KZB$$

where

$$\dot{W} = WD - UD \cdot SAL^*$$

$$\dot{W}\dot{W} = -QW \cdot VT$$

$$TY_{aero} = (MO + MAL \cdot WP + MAD \cdot (\dot{W} + \dot{W}\dot{W}) + MQ \cdot QO + MU \cdot UP + MDE \cdot ELE + MTR + MSP \cdot SPO + MGE \cdot KGE + MDS \cdot STA + MB) \cdot KMB$$

NONDIMENSIONAL EQUATIONS

$$FX_{aero} = QS \cdot (XO + XA \cdot \hat{ALP} + XU \cdot UP + XDE \cdot \hat{ELE} + XTR + XSP \cdot \hat{SPO} + XGE \cdot KGE) \cdot KXB$$

$$FZ_{aero} = QS \cdot (ZO + ZA \cdot \hat{ALP} + (ZAD \cdot (\hat{ALPHA} - \hat{QW}) + ZQ \cdot \hat{QO}) \cdot C / (2 \cdot VT) + ZU \cdot UP + ZDE \cdot \hat{ELE} + ZTR + ZSP \cdot \hat{SPO} + ZGE \cdot KGE + ZDS \cdot \hat{STA}) \cdot KZB$$

where

$$\hat{ALPHA} = (WD - \hat{AL} \cdot UD) / UO^*$$

$$\hat{ALP} = ALP \cdot \pi / 180, \text{ etc. for } \hat{ELE}, \hat{QW}, \hat{QO}, \hat{AL}, \hat{SPO}, \hat{STA}$$

$$TY_{aero} = QS \cdot C \cdot (MO + MAL \cdot \hat{ALP} + (MAD \cdot (\hat{ALPHA} - \hat{QW}) + MQ \cdot \hat{QO}) \cdot C / (2 \cdot VT) + MU \cdot UP + MDE \cdot \hat{ELE} + MTR + MSP \cdot \hat{SPO} + MGE \cdot KGE + MDS \cdot \hat{STA} + MB) \cdot KMB$$

FORCE AND TORQUE SUM:

$$FX_{sum} = FX_{aero} + FX1 \cdot CAL + FZ1 \cdot SAL$$

$$FZ_{sum} = FZ_{aero} + FZ1 \cdot CAL - FX1 \cdot SAL$$

$$FX2 = FX_{sum} \cdot CAL - FZ_{sum} \cdot SAL$$

$$FZ2 = FZ_{sum} \cdot CAL + FX_{sum} \cdot SAL$$

$$TY2 = TY_{aero} + TY1 - XP \cdot (FZ_{aero} \cdot CAL + FX_{aero} \cdot SAL)$$

ACCELERATIONS:

$$UD = FX2 / MA + EU$$

$$WD = FZ2 / MA + EW$$

\*Small alpha angle approximation.

# OL

## LONGITUDINAL STABILITY AND CONTROL DERIVATIVES: OL

	BIAS	ALPHA	U	ALPHA	Q	$\delta$ ELEV
FX (DRAG)	$C_{X_0}$ XO	$C_{X_\alpha}$ XA	$C_{X_U}$ XU			$C_{X_{\delta e}}$ XDE
FZ (LIFT)	$C_{Z_0}$ ZO	$C_{Z_\alpha}$ ZA	$C_{Z_U}$ ZU	$C_{Z_{\dot{\alpha}}}$ ZAD	$C_{Z_Q}$ ZQ	$C_{Z_{\delta e}}$ ZDE
TY=M (PITCH)	$C_{M_0}$ MO	$C_{M_\alpha}$ MAL	$C_{M_U}$ MU	$C_{M_{\dot{\alpha}}}$ MAD	$C_{M_Q}$ MQ	$C_{M_{\delta e}}$ MDE
	TRUNK	SPOILERS	GROUND EFFECT	LARGE SIDE SLIP	STABIL- IZER	BETA
	$C_{X_{TR}}$ XTR	$C_{X_{SP}}$ XSP	$C_{X_{GE}}$ XGE	$K_{C_{XB}}$ KXB		
	$C_{Z_{TR}}$ ZTR	$C_{Z_{SP}}$ ZSP	$C_{Z_{GE}}$ ZGE	$K_{C_{ZB}}$ KZB	$C_{Z_{\delta S}}$ ZDS	
	$C_{M_{TR}}$ MTR	$C_{M_{SP}}$ MSP	$C_{M_{GE}}$ MGE	$K_{C_{MB}}$ KMB	$C_{M_{\delta S}}$ MDS	$C_{M_B}$ CMB

FIRST ROW = NON-DIM. AERO-COEFFICIENTS  
 SECOND ROW = EASY NAMES

FOSTER MILLER  
TRUNK OUTPUT MODEL  
OUTPUTS

00

QUANTITY NAME	DESCRIPTION	UNITS
QFN	TOTAL FAN FLOW	CFS
QPT	PLENUM-TO-TRUNK FLOW	CFS
QPC	PLENUM-TO-CUSHION FLOW	CFS
QPA	PLENUM-TO-ATMOSPHERE FLOW	CFS
QV	PRESSURE RELIEF VALVE FLOW	CFS
QTC	TRUNK-TO-CUSHION FLOW	CFS
QTA	TRUNK-TO-ATMOSPHERE FLOW	CFS
QCA	CUSHION-TO-ATMOSPHERE FLOW	CFS
PAF	FAN INLET PRESSURE,	PSFG
PF	FAN PRESSURE RISE	PSF
FCY	TOTAL VERTICAL FORCE	LBS
FTP	TRUNK CONTACT FORCE	LBS
FCT	TRUNK DAMPING FORCE	LBS
FCP	CUSHION FORCE	LBS
FDF	AERO DRAG FORCE IN HEAVE	LBS
TX	TOTAL TORQUE X AXIS	FT/LBS
TTX	TRUNK PRESSURE TORQUE X AXIS	FT/LBS
TQX	TRUNK DAMPING TORQUE X AXIS	FT/LBS
TCX	CUSHION PRESSURE TORQUE X AXIS	FT/LBS
TDX	AERO DRAG TORQUE X AXIS	FT/LBS
TZ	TOTAL TORQUE Z AXIS	FT/LBS
TTZ	TRUNK PRESSURE TORQUE Z AXIS	FT/LBS
TQZ	TRUNK DAMPING TORQUE Z AXIS	FT/LBS
TDZ	AERO DRAG TORQUE Z AXIS	FT/LBS
TCZ	CUSHION PRESSURE TORQUE Z AXIS	FT/LBS
TFZ	GROUND FRICTION TORQUE Z AXIS	FT/LBS
HY	TRUNK HEIGHT	FT
R1	OUTER TRUNK RADIUS OF CURV	FT
R2	INNER TRUNK RADIUS OF CURV	FT
L1	TRUNK LENGTH OUTER-HORIZ ATTACH POINT	FT
L2	TRUNK LENGTH INNER-HORIZ ATTACH POINT	FT
AGP	AREA OF CUSHION GAP	SQ FT
ACH	AREA OF CUSHION	SQ FT
XTN	AREA OF TRUNK-GROUND CONTACT	SQ FT
XTA	TRUNK-ATMOS AREA IN CONTACT AREA	SQ FT
XTC	TRUNK-CUSHION AREA IN CONTACT AREA	SQ FT
ATA	TRUNK TO ATMOS AREA	SQ FT
ATC	TRUNK TO CUSHION AREA	SQ FT
VTK	TRUNK VOLUME	CU FT
VCH	CUSHION VOLUME	CU FT

PT

PITCH THRUSTER

INPUT

PHYSICAL QUANTITY NAME	PORT NO.	DESCRIPTION	UNITS
ED		ENGINE DEPENDENCE INDICATOR 0 = NO 1 = YES	---
TM		THRUSTER MAXIMUM FORCE FOR ENGINE-INDEPENDENT SYSTEM (i.e., ED = 0)	LBS
ST		SLOPE FOR VECTORED THRUST AS FUNCTION OF ENGINE THRUST	---
SR		SLOPE OF ENGINE THRUST REDUCTION AS FUNCTION OF VECTORED THRUST	---
C1		SATURATION FUNCTION SLOPE	---
C2		SATURATION SLOPE	---
SIG		AIRCRAFT CONTROL SYSTEM SIGNAL TO THRUSTER	---
GA		FIRST ORDER LAG GAIN	---
TC		FIRST ORDER LAG TIME CONSTANT	SEC
TH		ENGINE THRUST	LBS
XA		THRUSTER PITCH MOMENT AEM	FT

OUTPUT

PHYSICAL QUANTITY NAME	PORT NO.	DESCRIPTION	UNITS
*FX		ENGINE THRUST REDUCTION	LBS
FZ		VECTORED THRUST VERTICAL FORCE	LBS
TY		PITCH MOMENT DUE TO THRUSTER	FT-LBS

Reference: Listing -- Volume II, Section 4.4.4

\* State Variables

PT

PITCH THRUSTER

EQUATIONS:

TVA = TM	ED = 0
TVA = ST*TH	ED = 1
C3 = TVA/C1	
C6 = -C3	
C4 = C1	
C5 = C2	
CALL SA(FZ,SIG,C1. . . . .C6)	
FR = -SR*ABS(FZ)	} ED = 1
F $\dot{X}$ = (FR*GA-FX)/TC	
TY = -FZ*XA	

RANDOM NUMBER GENERATOR FOR WIND MODEL

RA

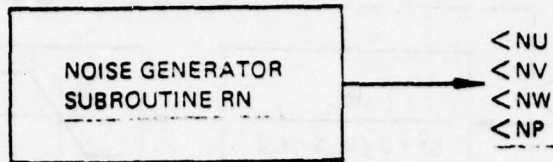

OUTPUT

PHYSICAL QUANTITY NAME	PORT NO.	DESCRIPTION	UNITS
NU, NV, NW NP		Noise samples for U, V, W gust velocities Noise sample for P angular rate gust	

METHOD:

Call RN(VAR, DUM, SIG, AMN)

where

VAR = Gaussian random output variable

DUM = Internal variable to start RN

SIG = Standard deviation of VAR =  $\sqrt{2 \cdot \Delta}$  ,

where  $\Delta$  = integrator stepsize

AMN = Var mean value = 0.

NOTE: 1) RA can only be used with the fixed step integrator which is specified by the command: INT MODE = 3.

2) RN is a standard component in standard component list if desired for separate use.

References: Listing -- Volume II, Section 3.5.15

# RATE GYRO PACKAGE

# RG

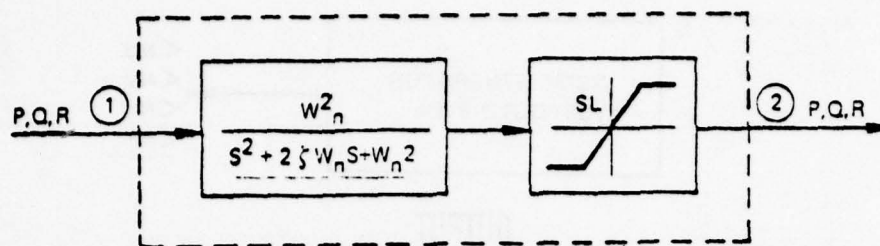

## INPUT

PHYSICAL QUANTITY NAME	PORT NO.	DESCRIPTION	UNITS
P,Q,R	1	Three axis angular rates	DEG/sec
SL		Rate gyro saturation-level (Same for all axes)	rad/sec
DMP		Rate gyro damping coefficient, $\zeta$	
WN		Rate gyro natural frequency, $w_n$	rad/sec

## OUTPUT

PHYSICAL QUANTITY NAME	PORT NO.	DESCRIPTION	UNITS
*P,Q,R	2	Three axis angular rates as output by gyros-states	DEG/sec
*PX,QX,RX		Intermediate states associated with each rate gyro	

### EQUATIONS:

$$FB = P2$$

$$IF(/P2/ SL) FB = 100*(P2-SIGN(SL,P2)) + SIGN(SL,P2)$$

$$\dot{P}X = (P1-FB)*WN$$

$$\dot{P}2 = (PX-2*DMP*FB)*WN$$

NOTE: Component XP should be used to convert to and from body axes to gyro axes.

\*These output quantities are states.

References: Listing -- Volume II, Section 3.4.7

1. These equations are repeated for Q and R rates.
2. Saturation of output state is accomplished by increasing feedback gain by 100 if output exceeds saturation limit.

# RT

## ROLL THRUSTER

### INPUT

PHYSICAL QUANTITY NAME	PORT NO.	DESCRIPTION	UNITS
ED		ENGINE DEPENDENCE INDICATOR 0 = NO 1 = YES	---
TM		THRUSTER MAXIMUM FORCE FOR ENGINE-INDEPENDENT SYSTEM (i.e. ED = 0)	LBS
ST		SLOPE FOR VECTORED THRUST AS FUNCTION OF ENGINE THRUST	---
SR		SLOPE OF ENGINE THRUST REDUCTION AS FUNCTION OF VECTORED THRUST	---
C1		SATURATION FUNCTION SLOPE	---
C2		SATURATION SLOPE	---
SIG		AIRCRAFT CONTROL SYSTEM SIGNAL TO THRUSTER	---
GA		FIRST ORDER LAG GAIN	---
TC		FIRST ORDER LAG TIME CONSTANT	SEC
TH		ENGINE THRUST	LBS
YA		THRUSTER ROLL MOMENT ARM	FT

### OUTPUT

PHYSICAL QUANTITY NAME	PORT NO.	DESCRIPTION	UNITS
*FX		ENGINE THRUST REDUCTION	LBS
FZO		VECTORED THRUST VERTICAL FORCE	LBS
TX		ROLL MOMENT DUE TO THRUSTER	FT-LBS

References: Listing -- Volume II, Section 4.4.5

\* State Variables

RT

RT

ROLL THRUSTER

EQUATIONS:

$$\begin{aligned}
 &TVA = TM \quad ED = 0 \\
 &TVA = ST*TH \quad ED = 1 \\
 &C3 = TVA/C1 \\
 &C6 = -C3 \\
 &C4 = C1 \\
 &C5 = C2 \\
 &CALL SA(FZ, SIG, C1. . . . C6) \\
 &FR = -SR*ABS(FZ) \quad \left. \begin{array}{l} \\ \\ \\ \end{array} \right\} ED = 1 \\
 &FX = (FR*GA-FX)/TC \\
 &TX = FZ*YA
 \end{aligned}$$

# SA

## SATURATION FUNCTION

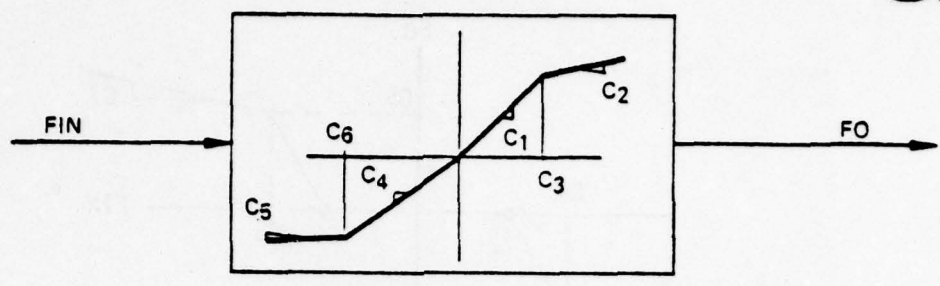

### INPUT

PHYSICAL QUANTITY NAME	PORT NO.	DESCRIPTION	UNITS
FIN		Input quantity	
C1		Slope $0 < FIN < C3$ *	
C2		Saturation Slope $FIN > C3$	
C3		Positive saturation intercept	
C4		Slope $0 > FIN > C6$ *	
C5		Saturation Slope $FIN < C6$	
C6		Negative saturation intercept	

### OUTPUT

PHYSICAL QUANTITY NAME	PORT NO.	DESCRIPTION	UNITS
FO		Output quantity	

### EQUATIONS:

$$FO = C1 \cdot C3 + C2 \cdot (FIN - C3) \quad \text{if } FIN > C3$$

$$FO = C1 \cdot FIN \quad \text{if } 0 < FIN < C3$$

$$FO = C4 \cdot FIN \quad \text{if } 0 > FIN > C6$$

$$FO = C4 \cdot C6 + C5 \cdot (FIN - C6) \quad \text{if } FIN < C6$$

\* Setting  $C1, -C4 = 0$  may cause difficulty at origin.

References: Listing -- Volume II, Section 3.5.11

# SATURATION WITH DEAD ZONE

SE

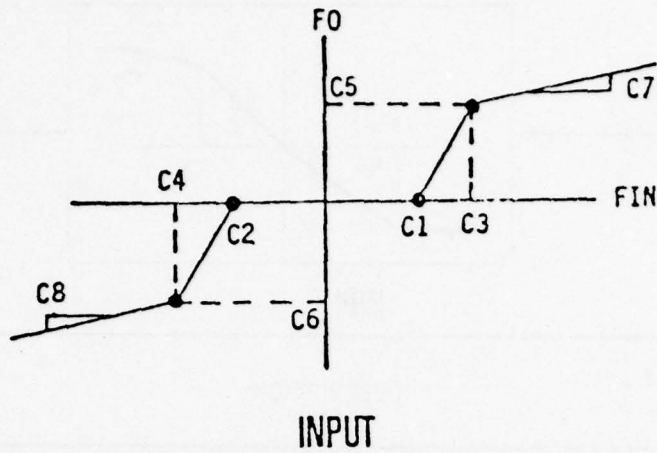

PHYSICAL QUANTITY NAME	PORT NO.	DESCRIPTION	UNITS
FIN		INPUT VARIABLE	
C1		POSITIVE LIMIT OF DEAD ZONE	
C2		NEGATIVE LIMIT OF DEAD ZONE	
C3		POSITIVE FIN SATURATION INTERCEPT	
C4		NEGATIVE FIN SATURATION INTERCEPT	
C5		POSITIVE SATURATION LIMIT ON FO	
C6		NEGATIVE SATURATION LIMIT ON FO	
C7		SATURATION SLOPE (FIN > 0)	
C8		SATURATION SLOPE (FIN < 0)	

## OUTPUT

PHYSICAL QUANTITY NAME	PORT NO.	DESCRIPTION	UNITS
FO		OUTPUT VARIABLE	

References: Listing -- Volume II, Section 3.5.12

SB

### SATURATION WITH DEAD ZONE

#### EQUATIONS:

$$FO = C5 + C7 * (FIN - C3) \quad \text{if } FIN > C3$$

$$FO = C6 + C8 * (FIN - C4) \quad \text{if } FIN < C4$$

$$FO = SLZERO * FIN$$

$$FO = YP + SLPLUS * (FIN - C1) \quad \text{if } FIN > C1$$

$$FO = YN + SLNEG * (FIN - C2) \quad \text{if } 0 > FIN > C2$$

$$SLZERO = .001 * C6 / C2$$

$$SLZERO = .001 * C5 / C1 \quad \text{if } C5 < -C6$$

$$YP = SLZERO * C1$$

$$YN = SLZERO * C2$$

$$SLNEG = (C6 - YN) / (C4 - C2)$$

$$SLPLUS = (C5 - YP) / (C3 - C1)$$

# GENERALIZED SIX DEGREE OF FREEDOM RIGID BODY DYNAMICS

# SG

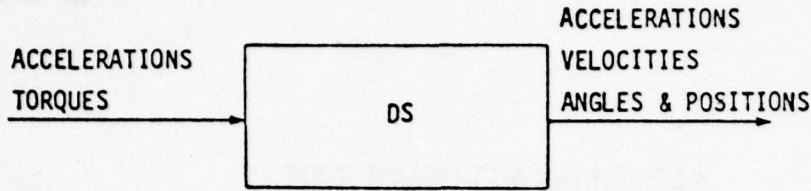

## INPUT

PHYSICAL QUANTITY NAME	PORT NO.	DESCRIPTION	UNITS
UD,VD,WD TX,TY,TZ IXX,IYY IZZ IXZ,IXY IYZ		X, Y, Z BODY AXIS LINEAR ACCELERATIONS X, Y, Z BODY AXIS TORQUES X, Y, Z BODY AXIS MOMENTS OF INERTIA X-Z, X-Y, Y-Z CROSS PRODUCTS OF INERTIA	FT/SEC <sup>2</sup> FT-LBS SLUG-FT <sup>2</sup> SLUG-FT <sup>2</sup>

## OUTPUT

PHYSICAL QUANTITY NAME	PORT NO.	DESCRIPTION	UNITS
*U,V,W *P,Q,R *ROL,PIT, YAW *X, Y XD, YD *ALT PD,QD,RD RØD,PID, YAD		X,Y,Z BODY AXIS LINEAR VELOCITIES X,Y,Z BODY AXIS ANGULAR RATES EULER ANGLES, BODY TO INERTIAL AXES HORIZONTAL POSITIONS(EARTH AXIS) HORIZONTAL POSITION RATES VERTICAL ALTITUDE FROM SEA-LEVEL X,Y,Z BODY AXIS ANGULAR ACCELERATIONS ROLL, PITCH, YAW ANGLE RATES	FT/SEC DEG/SEC DEG FT FT/SEC FT DEG/SEC <sup>2</sup> DEG/SEC

### ASSUMPTIONS:

1. Constant gravity, flatearth model.
  2. Rigid Body
- \* These output quantities are states.

Note: If using only 0L or DL, the unused inputs must be set to zero.

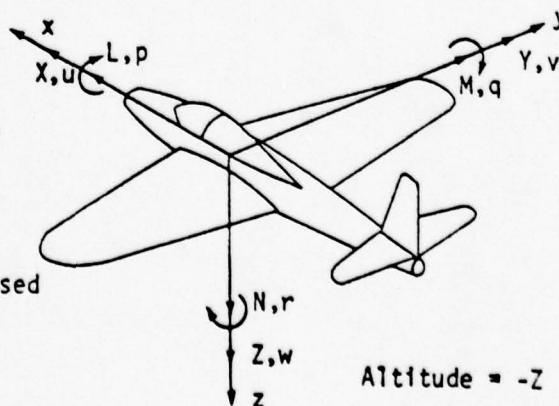

## GENERALIZED SIX DEGREE OF FREEDOM EQUATIONS OF MOTION

### o LINEAR VELOCITY EQUATIONS

$$\dot{U} = UD \quad \dot{V} = VD \quad \dot{W} = WD$$

### o ANGULAR VELOCITY EQUATIONS ( $\hat{P}=P \pi/180$ , etc. for $\hat{Q}, \hat{R}, \hat{P}, \hat{Q}, \hat{R}$ )

$$\hat{P} * I_{XX} = T_X - \hat{Q} * \hat{R} * (I_{ZZ} - I_{YY}) + (\hat{P} * \hat{Q} + \hat{R}) * I_{XZ} - (\hat{P} * \hat{R} - \hat{Q}) * I_{XY} + (\hat{Q}^2 - \hat{R}^2) * I_{YZ}$$

$$\hat{Q} * I_{YY} = T_Y - \hat{P} * \hat{R} * (I_{XX} - I_{ZZ}) + (\hat{R}^2 - \hat{P}^2) * I_{XZ} + (\hat{Q} * \hat{R} + \hat{P}) * I_{XY} - (\hat{P} * \hat{Q} - \hat{R}) * I_{YZ}$$

$$\hat{R} * I_{ZZ} = T_Z - \hat{Q} * \hat{P} * (I_{YY} - I_{XX}) + (\hat{P} - \hat{Q} * \hat{R}) * I_{XZ} + (\hat{P} * \hat{R} + \hat{Q}) * I_{YZ} + (P^2 - Q^2) * I_{XY}$$

### o ANGULAR POSITION EQUATIONS\*

$$PIT = Q * CR - R * SP$$

$$YAW = (Q * SR + R * CR) / CP$$

$$ROL = P + YAW * SP$$

### o LINEAR POSITION EQUATIONS\*

$$\dot{X} = U(CY * CP) + V(-SY * CR + CY * SP * SR) + W(SY * SR + CY * SP * CR)$$

$$\dot{Y} = U(SY * CP) + V(CY * CR + SY * SP * SR) + W(-CY * SR + SY * SP * CR)$$

$$\dot{ALT} = U * SP - V(CP * SR) - W(CP * CR)$$

\* The following abbreviations are used in these equations:

$$SR = \sin(ROL)$$

$$CR = \cos(ROL)$$

$$SP = \sin(PIT)$$

$$CP = \cos(PIT)$$

$$SY = \sin(YAW)$$

$$CY = \cos(YAW)$$

References: Listing -- Volume II, Section 4.3.1

Analysis -- Volume I, Section 2.4.1

SV

SUM LINEAR AND ANGULAR VELOCITIES

INPUT

PHYSICAL QUANTITY NAME	PORT NO.	DESCRIPTION	UNITS
UWS, VWS, WWS UG, VG, WG PG, QG, RG		X, Y, Z BODY AXES STEADY/SHEAR WIND COMPONENTS X, Y, Z BODY AXES GUST WIND COMPONENTS X, Y, Z BODY AXES GUST ANGULAR COMPONENTS	FT/SEC FT/SEC DEG/SEC

OUTPUT

PHYSICAL QUANTITY NAME	PORT NO.	DESCRIPTION	UNITS
UW, VW, WW PW, QW, RW		SUM OF X, Y, Z BODY AXES WIND VELOCITIES X, Y, Z BODY AXES ANGULAR VELOCITIES	FT/SEC DEG/SEC

EQUATIONS:

$$\begin{aligned}
 UW &= UWS + UG \\
 VW &= VWS + VG \\
 WW &= WWS + WG \\
 PW &= PG \\
 QW &= QG \\
 RW &= RG
 \end{aligned}$$

References: Listing -- Volume II, Section 4.5.3

# SW

## ONE POLE SWITCH

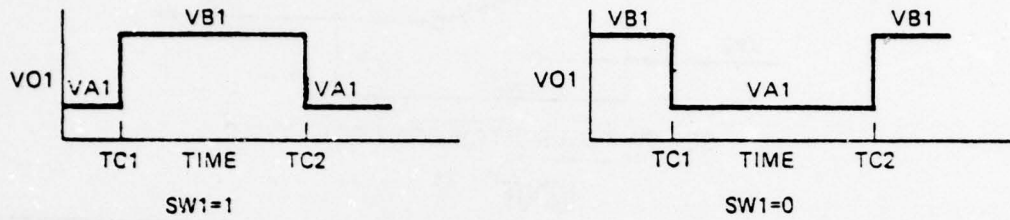
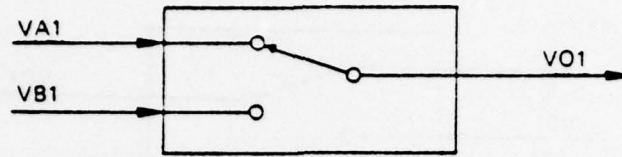

The switching operation may be controlled by either time or the input parameter SW1. The time dependence may be eliminated by setting TC1=1036

### INPUT

PHYSICAL QUANTITY NAME	PORT NO.	DESCRIPTION	UNITS
VA1		Input to switch	Any
VB1		Input to switch	Any
SW1		Switch control parameter	---
TC1		Time for first switching	Sec
TC2		Time for second switching	Sec

### OUTPUT

PHYSICAL QUANTITY NAME	PORT NO.	DESCRIPTION	UNITS
VO1		Output from switch	Any

### EQUATIONS:

$$VO1 = VA1 \text{ if } SW1=1 \text{ and } t < TC1 \text{ or } t > TC2$$

$$\text{or if } SW1=0 \text{ and } TC1 < t < TC2$$

$$VO1 = VB1 \text{ if } SW1=0 \text{ and } t < TC1 \text{ or } t > TC2$$

$$\text{or if } SW1=1 \text{ and } TC1 < t < TC2$$

where:  $t = \text{TIME, seconds.}$

Reference Listing -- Volume II, Section 3.5.1

SX

TWO POLE SWITCH

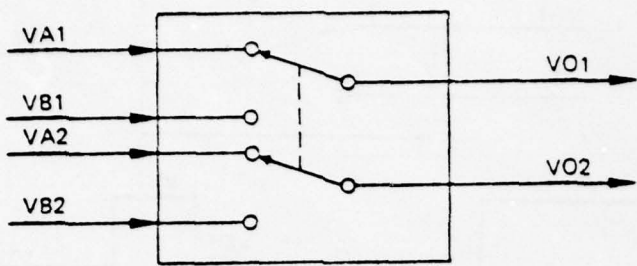

SEE SW FOR SWITCH CONTROL LOGIC

INPUT

PHYSICAL QUANTITY NAME	PORT NO.	DESCRIPTION	UNITS
VA1		Input to switch 1	Any
VA2		Input to switch 2	Any
VB1		Input to switch 1	Any
VB2		Input to switch 2	Any
*SW1		Switch control parameter	----
TC1		Time for first switching	Sec
TC2		Time for second switching (TC2>TC1)	Sec

OUTPUT

PHYSICAL QUANTITY NAME	PORT NO.	DESCRIPTION	UNITS
V01		Output from switch 1	
V02		Output from switch 2	

\* SW1 = 1 V0 = VB  
 = 0 V0 = VA

References: Listing -- Volume II, Section 3.5.2

SY

THREE POLE SWITCH

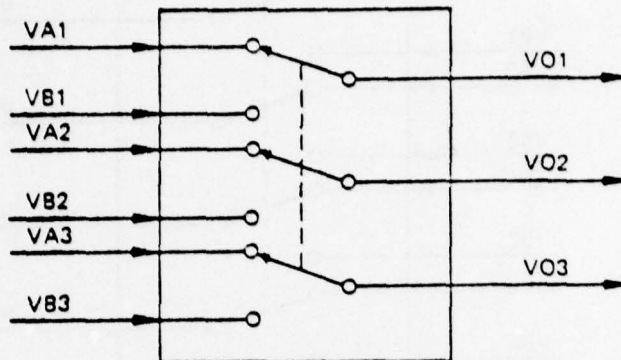

SEE SW FOR SWITCH CONTROL LOGIC

INPUT

PHYSICAL QUANTITY NAME	PORT NO.	DESCRIPTION	UNITS
VA1		Input to switch 1	Any
VA2		Input to switch 2	Any
VA3		Input to switch 3	Any
VB1		Input to switch 1	Any
VB2		Input to switch 2	Any
VB3		Input to switch 3	Any
*SW1		Switch control parameter	----
TC1		Time for first switching	Sec
TC2		Time for second switching (TC2-GT-TC1)	Sec

OUTPUT

PHYSICAL QUANTITY NAME	PORT NO.	DESCRIPTION	UNITS
VO1		Output from switch 1	Any
VO2		Output from switch 2	Any
VO3		Output from switch 3	Any

\* SW1 = 1 VO = VB  
 = 0 VO = VA

References: Listing -- Volume II, Section 3.5.3

# SZ

## FOUR POLE SWITCH

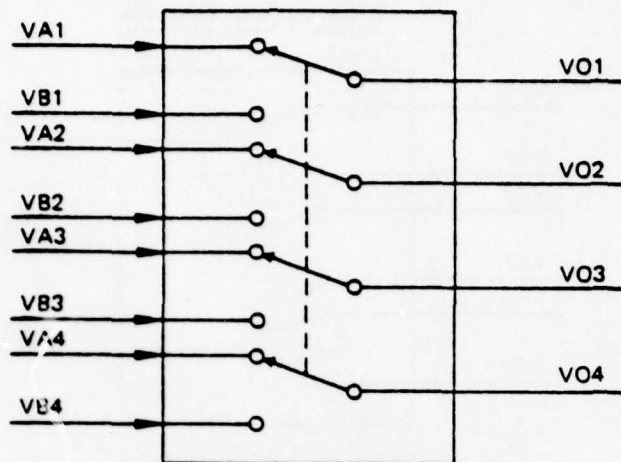

SEE SW FOR SWITCH CONTROL LOGIC

### INPUT

PHYSICAL QUANTITY NAME	PORT NO.	DESCRIPTION	UNITS
VA1		Input to switch 1	Any
VA2		Input to switch 2	Any
VA3		Input to switch 3	Any
VA4		Input to switch 4	Any
VB1		Input to switch 1	Any
VB2		Input to switch 2	Any
VB3		Input to switch 3	Any
VB4		Input to switch 4	Any
*SW1		Switch control parameter	----
TC1		Time for first switching	Sec
TC2		Time for second switching (TC2-GT-TC1)	Sec

### OUTPUT

PHYSICAL QUANTITY NAME	PORT NO.	DESCRIPTION	UNITS
VO1		Output from switch 1	Any
VO2		Output from switch 2	Any
VO3		Output from switch 3	Any

\* SW1 = 1. VO = VB  
 = 0 VO = VA

References: Listing -- Volume II, Section 3.5.4

# SUM TWO SETS OF 3 AXIS FORCES AND TORQUES

**S2**

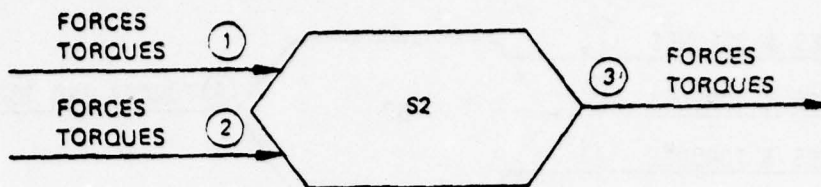

## INPUT

PHYSICAL QUANTITY NAME	PORT NO.	DESCRIPTION	UNITS
FX,FY,FZ	1	X,Y,Z body axis input forces, port 1	LBS
TX,TY,TZ	1	X,Y,Z body axis input torques, port 1	FT-LBS
FX,FY,FZ	2	X,Y,Z body axis input forces, port 2	LBS
TX,TY,TZ	2	X,Y,Z body axis input torques, port 2	FT-LBS

## OUTPUT

PHYSICAL QUANTITY NAME	PORT NO.	DESCRIPTION	UNITS
FX,FY,FZ	3	X,Y,Z body axis output forces, port 3	LBS
TX,TY,TZ	3	X,Y,Z body axis output torques, port 3	FT-LBS

### EQUATIONS:

$$FX3 = FX1 + FX2$$

$$FY3 = FY1 + FY2$$

$$FZ3 = FZ1 + FZ2$$

$$TX3 = TX1 + TX2$$

$$TY3 = TY1 + TY2$$

$$TZ3 = TZ1 + TZ2$$

References: Listing -- Volume II, Section 3.5.17

SUM FORCES AND MOMENTS (3 SETS OF INPUTS)

S3

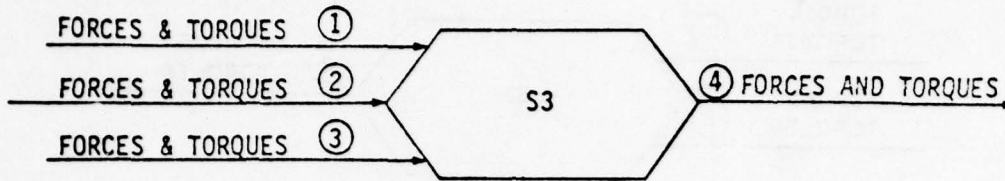

INPUT

PHYSICAL QUANTITY NAME	PORT NO.	DESCRIPTION	UNITS
FX,FY,FZ	1	X,Y,Z BODY AXIS INPUT FORCES, PORT 1	LBS
TX,TY,TZ	1	X,Y,Z BODY AXIS INPUT TORQUES, PORT 1	FT-LBS
FX,FY,FZ	2	X,Y,Z BODY AXIS INPUT FORCES, PORT 2	LBS
TX,TY,TZ	2	X,Y,Z BODY AXIS INPUT TORQUES, PORT 2	FT-LBS
FX,FY,FZ	3	X,Y,Z BODY AXIS INPUT FORCES, PORT 3	LBS
TX,TY,TZ	3	X,Y,Z BODY AXIS INPUT TORQUES, PORT 3	FT-LBS

OUTPUT

PHYSICAL QUANTITY NAME	PORT NO.	DESCRIPTION	UNITS
FX,FY,FZ	4	X,Y,Z BODY AXIS OUTPUT FORCES, PORT 4	LBS
TX,TY,TZ	4	X,Y,Z BODY AXIS OUTPUT TORQUES, PORT 4	FT-LBS

EQUATIONS:

$$\begin{aligned}
 FX4 &= FX1+FX2+FX3 \\
 FY4 &= FY1+FY2+FY3 \\
 FZ4 &= FZ1+FZ2+FZ3 \\
 TX4 &= TX1+TX2+TX3 \\
 TY4 &= TY1+TY2+TY3 \\
 TZ4 &= TZ1+TZ2+TZ3
 \end{aligned}$$

References: Listing -- Volume II, Section 3.5.18

# FOUR TABULAR FUNCTIONS OF TIME

# TA

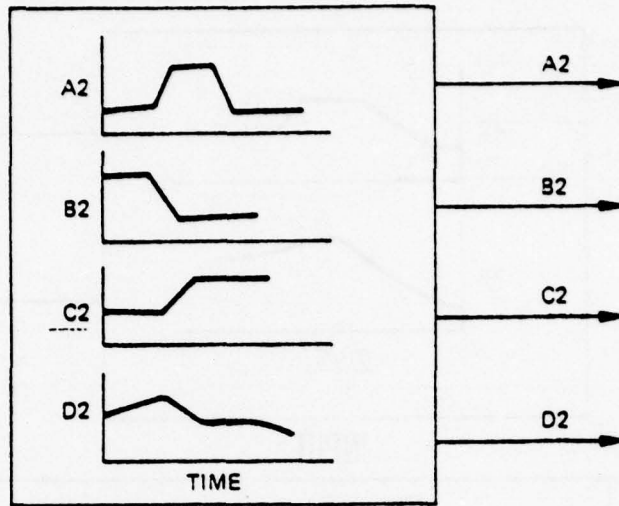

INPUT

PHYSICAL QUANTITY NAME	PORT NO.	DESCRIPTION	UNITS
A2T		Tabular data describing A2 vs. time	Any
B2T		Tabular data describing B2 vs. time	Any
C2T		Tabular data describing C2 vs. time	Any
D2T		Tabular data describing D2 vs. time	Any

OUTPUT

PHYSICAL QUANTITY NAME	PORT NO.	DESCRIPTION	UNITS
A2		Output quantity	Any
B2		Output quantity	Any
C2		Output quantity	Any
D2		Output quantity	Any

EQUATIONS:      References: Listing -- Volume II, Section 3.5.5

$$A2 = A2T(t)$$

$$B2 = B2T(t)$$

$$C2 = C2T(t)$$

$$D2 = D2T(t)$$

NOTE: 15 points are allowed per table. Linear interpolation is used between points. The last point in the table is used for values of time outside the table range. A warning is printed if all tables not loaded, but function still works.

## TWO TABULAR FUNCTIONS OF TIME

**TB**

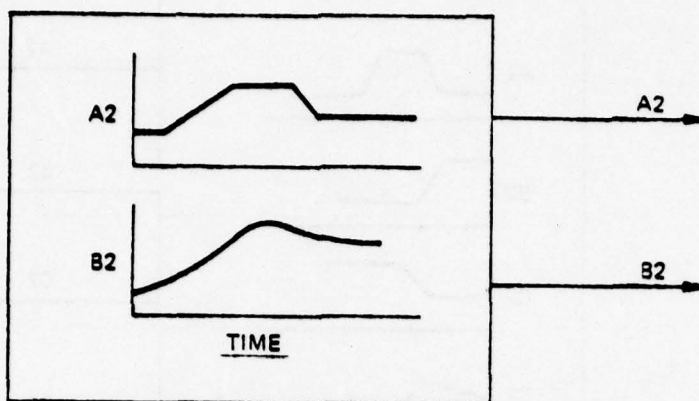

**INPUT**

PHYSICAL QUANTITY NAME	PORT NO.	DESCRIPTION	UNITS
A2T		Tabular data describing A2 vs. time	Any
B2T		Tabular data describing B2 vs. time	Any

**OUTPUT**

PHYSICAL QUANTITY NAME	PORT NO.	DESCRIPTION	UNITS
A2		Output quantity	Any
B2		Output quantity	Any

**EQUATIONS:**

$$A2 = A2T(t)$$

$$B2 = B2T(t)$$

**NOTE:** 15 points are allowed per table. Linear interpolation is used between points. The last point in the table is used for values of time outside the table range. If only one table is loaded, a warning message is printed but function will work.

**References:** Listing -- Volume II, Section 3.5.6

## THREE DEGREE OF FREEDOM RIGID BODY DYNAMICS (LATERAL)

## INPUT

PHYSICAL QUANTITY NAME	PORT NO.	DESCRIPTION	UNITS
VD TX,TZ IXX,IZZ IXZ PIT		Y BODY AXIS LINEAR ACCELERATION X,Z BODY AXIS TORQUES X,Z BODY AXIS MOMENTS OF INERTIA X-Z CROSS PRODUCT OF INERTIA PITCH ANGLE (BODY TO INERTIAL AXES)	FT/SEC <sup>2</sup> FT-LBS SLUG-FT <sup>2</sup> SLUG-FT <sup>2</sup> DEG

## OUTPUT

PHYSICAL QUANTITY NAME	PORT NO.	DESCRIPTION	UNITS
*V *P,R *ROL, YAW YD PD,RD		Y BODY AXIS LINEAR VELOCITY X,Z BODY AXIS ANGULAR RATES EULER ANGLES, BODY TO INERTIAL AXES HORIZONTAL POSITION RATE X,Z BODY AXIS ANGULAR ACCELERATIONS	FT/SEC DEG/SEC DEG FT/SEC DEG/SEC <sup>2</sup>

References: Analysis -- Volume I, Section 2.4.5

Listing -- Volume II, Section 4.3.5

\* State Variables

TD

### THREE DEGREE OF FREEDOM EQUATIONS OF MOTION (LATERAL)

o LINEAR VELOCITY EQUATIONS

$$\dot{V} = VD$$

o ANGULAR VELOCITY EQUATIONS ( $\hat{P}=P \pi/180$ , etc. for  $\hat{Q}, \hat{R}, \hat{P}, \hat{Q}, \hat{R}$ )

$$\hat{P} * I_{XX} = TX + \hat{R} * IXZ$$

$$\hat{R} * I_{ZZ} = TZ + (\hat{P}) * IXZ$$

o ANGULAR POSITION EQUATIONS\*

$$YAW = R * CR / CP$$

$$ROL = P + YAW * SP$$

o LINEAR POSITION EQUATIONS\*

$$YD = V(CY * CR + SY * SP * SR)$$

\*The following abbreviations are used in these equations:

$$\begin{aligned} SR &= \sin(ROL) \\ SP &= \sin(PIT) \\ SY &= \sin(YAW) \end{aligned}$$

$$\begin{aligned} CR &= \cos(ROL) \\ CP &= \cos(PIT) \\ CY &= \cos(YAW) \end{aligned}$$

# TRANSFER FUNCTION

# TF

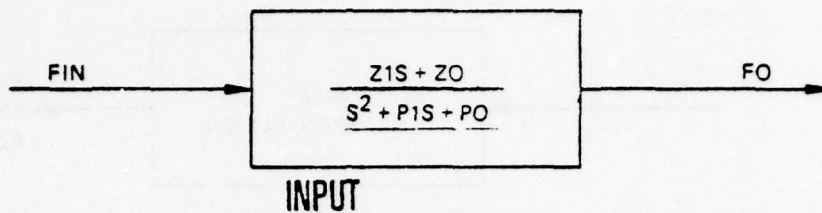

PHYSICAL QUANTITY NAME	PORT NO.	DESCRIPTION	UNITS
FIN		Input quantity	
Z0		Numerator coefficient	
Z1		Numerator coefficient	
P0		Denominator coefficient	(RAD/SEC) <sup>2</sup>
P1		Denominator coefficient	(RAD/SEC)

## OUTPUT

PHYSICAL QUANTITY NAME	PORT NO.	DESCRIPTION	UNITS
*X1		Intermediate state	
*FO		Output quantity	

\*State Variables

EQUATIONS:

$$\dot{X}_1 = Z_0 \cdot F_{IN} - P_0 \cdot F_0$$

$$\dot{F}_0 = X_1 + Z_1 \cdot F_{IN} - P_1 \cdot F_0$$

NOTE: d.c. gain  $\frac{Z_0}{P_0}$  infinite freq. gain = 0.

References: Listing -- Volume II, Section 3.4.5

# ENGINE THRUST BODY AXIS TRANSFORM

TG

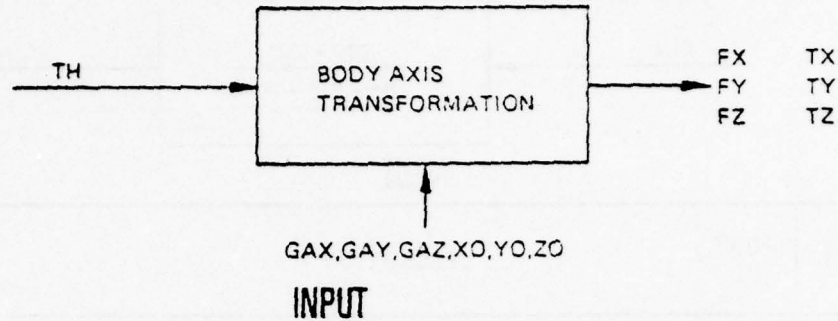

PHYSICAL QUANTITY NAME	PORT NO.	DESCRIPTION	UNITS
TH		Engine thrust	LBS
GAX,GAY,GAZ		X,Y,Z body axis direction cosines	
XO,YO,ZO		X,Y,Z thrust location components	FT

## OUTPUT

PHYSICAL QUANTITY NAME	PORT NO.	DESCRIPTION	UNITS
FX,FY,FZ		X,Y,Z body axis forces	LBS
TX,TY,TZ		X,Y,Z body axis torques	FT-LBS

### EQUATIONS:

$$FX = TH * GAX$$

$$FY = TH * GAY$$

$$FZ = TH * GAZ$$

$$TX = YO * FZ - ZO * FY$$

$$TY = ZO * FX - XO * FZ$$

$$TZ = XO * FY - YO * FX$$

References: Listing -- Volume II, Section 3.5.19

# INELASTIC TRUNK MODEL

# TK

## INPUT

PHYSICAL QUANTITY NAME	PORT NO.	DESCRIPTION	UNITS
ABL (A,B,LO, I TYPE) XYZ (XA,YA,ZA, BET)		ARRAYS OF TRUNK ELEMENT DIMENSIONS: A, B, LO; AND I TYPE (0 = FROZEN, 1 = MEMBRANE) ARRAYS OF COORDINATES OF ELEMENT INBOARD ATTACH POINT: XA, YA, ZA; AND ELEMENT ANGLE BET (0 = SIDE ELE, NON ZERO = FRONT OR AFT ELE)	INCHES ----- INCHES DEG
DSM (D,S, MU)		ARRAYS OF: ELEMENT WIDTH D ELEMENT SCALING FACTORS, S ELEMENT COEFFICIENTS OF FRICTION IN X AND Y AXIS. MU	INCHES ----- -----
IAL (IS,AP, LP, LH)		ARRAYS OF: ELEMENT SET NUMBER, IS; ORIFICE AREA PER UNIT TRUNK AREA, AP; CIRCUMFERENTIAL DISTANCE FROM OUTB'D ATTACH POINT TO START OF PERFORATIONS, LP WIDTH OF PERFORATED AREA, LH	----- ----- INCHES
REL		TABULAR DATA: RELIEF VALVE AREA OPENING VS. TRUNK PRESSURE (GAGE)	INCHES SQ. IN. VS. PSIG
ZTR		VECTOR ARRAY CONTAINING TERRAIN ELEVATION DEFINITION	INCHES
ROL,PIT,YAW X, ALT U,V,W PA WCU,TCU		AIRPLANE ROLL, PITCH, YAW EULER ANGLES X, Z EARTH AXIS POSITIONS X, Y, Z BODY AXIS LINEAR VELOCITIES AMBIENT PRESSURE FLOW RATE AND TEMPERATURE OF AIR SUPPLY TO CUSHION	DEG FT FT/SEC PSIA LB/MIN,
WTR,TTR		FLOW RATE AND TEMPERATURE OF AIR SUPPLY TO TRUNK	LB/MIN, DEGR
NE		NUMBER OF ELEMENTS PER TRUNK SIDE (NEGATIVE VALUE IMPLIES SYMMETRIC MODEL ABOUT ROLL AXIS)	-----
CDG		DISCHARGE COEFF. FOR FLOW THROUGH GAP BETWEEN TRUNK AND GROUND	-----
NST NPT		NUMBER OF ELEMENT SHAPES OR PARAMETRIC SETS NO. OF ELEMENTS IN A ROW OR COLUMN IN THE PARAMETER SET	----- -----
BST,WLT		BODY STATION AND WATER LINE OF TRUNK AXIS	INCHES
CD1		DISCHARGE COEFF. FOR FREE PORTION OF TRUNK	-----
CD2		DISCHARGE COEFF. FOR FLATTENED PORTION OF TRUNK	-----
CDA		DISCHARGE COEFF. FOR FLOW THROUGH RELIEF VALVE	-----
BSC,WLC TAU		BODY STATION AND WATER LINE OF C.G. TIME CONSTANT FOR TRUNK AND CUSHION VOLUME RATE OF CHANGE	INCHES SEC

# INELASTIC TRUNK MODEL

# TK

## INPUT

PHYSICAL QUANTITY NAME	PORT NO.	DESCRIPTION	UNITS
P, Q, R AMO		X, Y, Z BODY AXIS ANGULAR VELOCITIES INDICATOR FOR TYPE OF SURFACE IN TERRAIN MODEL 0 = DEFINES A FLAT SURFACE, ZE=0 1 = DEFINES (1-COSINE) OR SINUSOIDAL SURFACE 2 = DEFINES PROFILE IN TABULAR FORM	DEG/SEC -----
FOR AMO =1 ANR DL H		NUMBER OF SEQUENTIAL (1-COSINE) BUMPS LENGTH OF BUMP HEIGHT OF BUMP (-VE MEANS A DIP)	----- FEET INCHES
FOR AMO =2 ANR DL H DMP		NO. OF DATA POINTS IN PROFILE DEFINITION INCREMENTAL DISTANCE BETWEEN POINTS CONSTANT ELEVATION SCALING FACTOR TRUNK DAMPING COEFFICIENT AS A FUNCTION OF TRUNK FLATTENED AREA PRINT CONTROL INDICATOR = 1 PRINTS ELEMENT VARIABLE VALUES EVERY PRINT INTERVAL	----- FEET ----- LB-SEC/IN /SQ IN -----
EPC			
VU CAV		BREAK POINT IN MU-VELOCITY CURVE EFFECTIVE AREA FOR TRUNK TO CUSHION VENT	IN/SEC SQ IN

## OUTPUT

PHYSICAL QUANTITY NAME	PORT NO.	DESCRIPTION	UNITS
FXT, FYT, FZT		X, Y, Z AXIS, AXIAL, LATERAL AND VERTICAL FORCE SUMMATION TERMS	LBS
TXT, TYT, TZT		X, Y, Z AXIS SUMMATION TERMS FOR ROLL, PITCH AND YAW MOMENTS	FT-LBS
*PT		TRUNK PRESSURE	PSIA
*VT		TRUNK VOLUME	CU FT
*PC		CUSHION PRESSURE	PSIA
*VC		CUSHION VOLUME	CU FT
WTA		AIR FLOW RATE, TRUNK TO ATMOSPHERE	LB/MIN
WCA		AIR FLOW RATE, CUSHION TO ATMOSPHERE	LB/MIN
WTC		AIR FLOW RATE, TRUNK TO CUSHION	LB/MIN

References: Analysis -- Volume I, Section IV

\* State Variables

Listing -- Volume II, Section 4.6.1

TK

## INELASTIC TRUNK MODEL

### EQUATIONS:

XBA = BSC-BST+XA  
YBA = YA  
ZBA = WLC-WLT+ZA  
RA = YA/COS(BET)  
CALL IC(NST,NPT,ITYPE,A,B,LO,DPR)  
PR = 0                      BET ≠ 0.  
PR = (PC-PA)/(PT-PA)      BET = 0.  
ZOFSU = TBL1(PR,AZO,DPR,NPT,IS,NA)  
ZOFS = S\*ZOFSU  
YOFS = S\*TBL2(PR,ZOFSU,ZOFSU,AYO,DPR,NPT,IS,NA)  
XBT = XBA+YOFS\*SIN(BET)  
YBT = E\*(YBA+YOFS\*COS(BET))      E = 1 (RHS)  
ZBT = ZBA+ZOFS                      = -1 (LHS)  
XET = X\*12.+XBT\*CPCY+YBT\*(SRSPCY-CRSY)+ZBT\*(SYSR+CYCRSP)  
ZET = -ALT\*12.-XBT\*SP+YBT\*CPSR+ZBT\*CRCP  
ZEG = TERRA(XET,AMO,ANR,DL,H,ZTR)  
ZGAP = -ZEG-ZET  
ZO = ZOFS+ZGAP  
ZOU = ZO/S

### LOADED SHAPE:

YO = S\*TBL2(PR,ZOU,ZOFSU,AYO,DPR,NPT,IS,NA)  
L1 = S\*TBL2(PR,ZOU,ZOFSU,AL1,DPR,NPT,IS,NA)  
L3 = S\*TBL2(PR,ZOU,ZOFSU,AL3,DPR,NPT,IS,NA)

TK

## INELASTIC TRUNK MODEL (CONTINUED)

EQUATIONS (CONT'D):

```

L3P = L3                                ITYPE = 1
L3P = S*TBL2(PR,ZOU,ZOFSU,AL3P,DPR,NPT,IS,NA)    ITYPE = 0
AS = S*S*TBL2(PR,ZOU,ZOFSU,AAS,DPR,NPT,IS,NA)
ACV = S*S*TBL2(PR,ZOU,ZOFSU,AACV,DPR,NPT,IS,NA)
DYO = S*TBL2(PR,ZOU,ZOFSU,SYO,DPR,NPT,IS,NA)
DACV = S*S*TBL2(PR,ZOU,ZOFSU,SACV,DPR,NPT,IS,NA) } if BET = 0
AT = D*L3
FT = (PT-PA)*AT
XBT = XBA+(YO+.5*L3)*SIN(BET)
YBT = E*(YBA+(YO+.5*L3)*COS(BET))
ZBT = ZBA+ZO
XBTD = ZBT*Q-YBT*R+U
YBTD = -ZBT*P+XBT*R+V
ZBTD = YBT*P-XBT*Q+W
XTD2 = XBTD*CP+YBTD*SPSR+ZBTD*SPCR
YTD2 = YBTD*CR-ZBTD*SR
ZTD = -XBTD*SP+YBTD*CPSR+ZBTD*CRCP
VET = SQRT(XTD2**2+YTD2**2)
UTO = MU*XMU(VET)
UTX = UTO*XTD2/VET
UTY = UTO*YTD2/VET
FFX = -UTX*FT
FFY = -UTY*FT
FD = DMP*AT*ZTD
FXT = FXT+FFX
FYT = FYT+FFY
FZT = FZT-FT-FD
TXT = TXT+(-(FT+FD)*YBT-FFY*ZBT)*.08333

```

TK

INELASTIC TRUNK MODEL (CONTINUED)

EQUATIONS (CONT'D):

$$\begin{aligned}TYT &= TYT + ((\bar{F}\bar{T} + \bar{F}\bar{D}) * XBT + \bar{F}\bar{F}\bar{X} * ZBT) * .08333 \\TZT &= TZT + (\bar{F}\bar{F}\bar{Y} * XBT - \bar{F}\bar{F}\bar{X} * YBT) * .08333\end{aligned}$$

FREE SHAPE:

$$\begin{aligned}AGAP &= ZGAP * D \\YO &= S * TBL2(PR, ZOFSSU, ZOFSSU, AYO, DPR, NPT, IS, NA) \\L1 &= S * TBL2(PR, ZOFSSU, ZOFSSU, AL1, DPR, NPT, IS, NA) \\AS &= S * S * TBL2(PR, ZOFSSU, ZOFSSU, AAS, DPR, NPT, IS, NA) \\ACV &= S * S * TBL2(PR, ZOFSSU, ZOFSSU, AACV, DPR, NPT, IS, NA) \\DYO &= S * TBL2(PR, ZOFSSU, ZOFSSU, SYO, DPR, NPT, IS, NA) \\DACV &= S * S * TBL2(PR, ZOFSSU, ZOFSSU, SACV, DPR, NPT, IS, NA) \\FF\bar{X} &= \bar{F}\bar{F}\bar{Y} = \bar{F}\bar{D} = \bar{F}\bar{T} = L3 = 0.\end{aligned} \quad \left. \vphantom{\begin{aligned}YO \\L1 \\AS \\ACV \\DYO \\DACV \\FF\bar{X}} \right\} \text{if BET} = 0$$

END ELEMENTS:

$$\begin{aligned}YBC &= E * (YBA + (2/3 * YO - 1/3 * RA) * \cos(BET)) \\AC &= .5 * D * (YO + RA) ** 2 / (YOFS + RA) \\VCS &= (ZO * AC - D * ACV * (2/3 * YO + RA) / (YO + RA)) * .0005787\end{aligned}$$

SIDE ELEMENTS:

$$\begin{aligned}YBC &= 0.5 * E * (YBA + YO) \\AC &= D * (YA + YO) \\VCS &= (ZO * AC - D * ACV) * .0005787 \\DVOL &= D * (ZO * DYO - DACV) \\VTS &= D * AS * .0005787 \\XBC &= XBA + (2/3 * YO - 1/3 * RA) * \sin(BET)\end{aligned}$$

TK

INELASTIC TRUNK MODEL (CONTINUED)

EQUATIONS (CONT'D)

$$\bar{F}C = (PC-PA)*AC$$

$$FZT = -\bar{F}C$$

$$TXT = -\bar{F}C*YBC$$

$$TYT = \bar{F}C*XBC$$

CALL PERF(ZGAP,L1,L3,L3P,LP,LH,RA,YO,YOFS,D,AP,PT,PC,PA,BET,AHA1,  
AHA2, AHC2, AHC1) If AP>0.

$$CACA = CDGAP*AGAP$$

$$CATA = CDH1*AHA1+2/3*CDH2*AHA2$$

$$CATC = CDH1*AHC1+2/3*CDH2*AHC2$$

$$FXT = 2.*FXT$$

$$FZT = 2.*FZT$$

$$TYT = 2.*TYT$$

$$VCS = 2.*VCS$$

$$VTS = 2.*VTS$$

$$DVOL = 2.*DVOL$$

$$CACA = 2.*CACA$$

$$CATA = 2.*CATA$$

$$CATC = 2.*CATC$$

$$FYT = TXT = TZT = 0.$$

$$AREL = REL(PT-PA)$$

$$CATA = CATA+CDA*AREL$$

$$\dot{V}C = (VCS-VC)/TAU$$

$$\dot{V}T = (VTS-VT)/TAU$$

CALL FSFLOW (PC,PA,TCU,CACA,1.,FN,SFN,WCA)

CALL FNFLOW (PT,PA,TTR,CATA,1.,FN,WTA)

CALL FNFLOW (PT,PC,TTR,CATC,1.,FN,WTC)

$$DPTA = (PT-PA) \geq .01$$

$$VC2 = VC \geq .002*DSLUM$$

} if symmetric model (no roll)

} if symmetric model (no roll)

## INELASTIC TRUNK MODEL (CONCLUDED)

EQUATIONS (CONCLUDED):

$$\begin{aligned} & \text{TCU} \\ \text{PCD1} &= (.0001389 * \text{RG} * \text{TCU} * (\text{WCU} + \text{WTC} - \text{WCA}) - 1.2 * \text{PC} * \text{VCD}) / \text{VC} \\ \text{PC} &= \text{PCD1} \\ \text{PT} &= (.0001389 * \text{RG} * \text{TTR} * (\text{WTR} - \text{WTC} - \text{WTA}) - 1.2 * \text{PT} * \text{VTD}) / \text{VT} \end{aligned}$$

The following abbreviations are used in these equations:

$$\begin{array}{lll} \text{SR} = \text{SIN}(\text{ROL}) & \text{CR} = \text{COS}(\text{ROL}) & \text{SY} = \text{SIN}(\text{YAW}) \\ \text{SP} = \text{SIN}(\text{PIT}) & \text{CP} = \text{COS}(\text{PIT}) & \text{CY} = \text{COS}(\text{YAW}) \end{array}$$

THREE DEGREE OF FREEDOM RIGID BODY DYNAMICS (LONGITUDINAL)

INPUT

PHYSICAL QUANTITY NAME	PORT NO.	DESCRIPTION	UNITS
UD, WD TY IYY RØL, YAW		X,Z BODY AXIS LINEAR ACCELERATIONS Y BODY AXIS TORQUE Y BODY AXIS MOMENT OF INERTIA EULER ANGLES (BODY TO INERTIAL AXES)	FT/SEC <sup>2</sup> FT-LBS SLUG-FT <sup>2</sup> DEG

OUTPUT

PHYSICAL QUANTITY NAME	PORT NO.	DESCRIPTION	UNITS
*U,W *Q *PIT XD *ALT QD		X,Z BODY AXIS LINEAR VELOCITIES Y BODY AXIS ANGULAR RATE EULER ANGLE, BODY TO INERTIAL AXES HORIZONTAL POSITION RATE VERTICAL ALTITUDE FROM SEAL LEVEL Y BODY AXIS ANGULAR ACCELERATION	FT/SEC DEG/SEC DEG FT/SEC FT DEG/SEC <sup>2</sup>

References: Listing -- Volume II, Section 4.3.4  
Analysis -- Volume I, Section 2.4.4

\* State Variables

## THREE DEGREE OF FREEDOM EQUATIONS OF MOTION (LONGITUDINAL)

## o LINEAR VELOCITY EQUATIONS

$$\dot{U} = UD \quad \dot{W} = WD$$

o ANGULAR VELOCITY EQUATIONS ( $\hat{P}=P \pi/180$ , etc. for  $\hat{Q}, \hat{R}, \hat{P}, \hat{Q}, \hat{R}$ )

$$\hat{Q} * I_{YY} = TY$$

## o ANGULAR POSITION EQUATIONS\*

$$PIT = Q * CR$$

## o LINEAR POSITION EQUATIONS\*

$$XD = U(CY * CP) + W(SY * SR + CY * SP * CR)$$

$$ALT = U * SP - W(CP * CR)$$

\* The following abbreviations are used in these equations:

$$SR = \text{SIN}(ROL)$$

$$SP = \text{SIN}(PIT)$$

$$SY = \text{SIN}(YAW)$$

$$CR = \text{COS}(ROL)$$

$$CP = \text{COS}(PIT)$$

$$CY = \text{COS}(YAW)$$

TR

TRANSFORM VECTORS BODY TO EARTH AXIS

INPUT

PHYSICAL QUANTITY NAME	PORT NO.	DESCRIPTION	UNITS
U,V,W RØL,PIT, YAW	1	VECTOR COORDINATES OF BODY AXES SYSTEM (VELOCITIES) EULER ANGLES BODY TO INERTIAL AXES	FT/SEC DEG

OUTPUT

PHYSICAL QUANTITY NAME	PORT NO.	DESCRIPTION	UNITS
U,V,W	2	VECTOR QUANTITIES ALONG EARTH X,Y, AND Z AXES (VELOCITIES)	FT/SEC

References: Listing -- Volume II, Section 3.5.20  
Analysis -- Volume I, Section 2.1

TRANSFORM VECTORS FROM BODY TO EARTH AXIS

EQUATIONS: (IN MATRIX FORM)

$$\begin{Bmatrix} U \\ V \\ W \end{Bmatrix}_{\text{Earth}} = \begin{bmatrix} \cos\phi & -\sin\phi & 0 \\ \sin\phi & \cos\phi & 0 \\ 0 & 0 & 1 \end{bmatrix} \begin{bmatrix} \cos\theta & 0 & \sin\theta \\ 0 & 1 & 0 \\ -\sin\theta & 0 & \cos\theta \end{bmatrix} \begin{bmatrix} 1 & 0 & 0 \\ 0 & \cos\phi & \sin\phi \\ 0 & \sin\phi & \cos\phi \end{bmatrix} \begin{Bmatrix} U \\ V \\ W \end{Bmatrix}_{\text{Body}}$$

ELASTIC TRUNK MODEL

TS

INPUTS

TABLE NAME	TABLE DESCRIPTION	
ABL **	-ELEMENT SET DATA ARRAY; ATTACH POINT SPACING, ATTACH POINT HEIGHT, MEMBRANE INSTALLED LENGTH, INITIAL MERIDIAN AND HOOP STRAINS, AND POISSONS RATIO	
XYZ **	-ELEMENT DATA ARRAY; X,Y,Z, COORDINATES OF INBOARD ATTACH POINT, AND ELEMENT ANGLES	
DM **	-ELEMENT DATA ARRAY; ELEMENT WIDTHS AND ELEMENT COEFFICIENTS OF FRICTION	
IAL **	-ELEMENT DATA ARRAY; ELEMENT SET NUMBERS ASSOCIATED WITH EACH ELEMENT, ORIFICE AREA PER UNIT AREA OF TRUNK SURFACE, DISTANCE FROM OUTBRD. ATTACH POINT TO BEGINNING OF PERFORATIONS (IN MEMBRANE FREE STATE), WIDTH OF PERFORATED AREA (IN MEMBRANE FREE STATE)	
END **	-END ELEMENT DATA ARRAY; RADIUS OF INBOARD ATTACH POINT, AND PARAMETER FOR MATERIAL CONSTRUCTION WHICH AFFECTS THE STRESS/STRAIN RELATIONSHIP	
PM **	-PILLOW ELEMENT DATA ARRAY; ELEMENT NUMBER ASSOCIATED WITH EACH PILLOW ELEMENT, COEFFICIENT OF FRICTION, PILLOW INFLATED HEIGHT, AND RATIO OF INFLATED PILLOW CONTACT WIDTH TO UNINFLATED WIDTH	
BWT **	-MISC. DATA ARRAY; BODY STATION AND WATER LINE OF TRUNK AXIS, BODY STATION AND WATER LINE OF C.G., AND TERRAIN MODEL PARAMETERS (SEE FUNCTION TERRA)	
SPH ***	-ELEMENT SET INPUT TABLE (TWO DIMENSIONAL); MERIDIAN LOADS VS. MERIDIAN STRAINS FOR MEMBRANE (LBS/INCH VS DIMENSIONLESS RATIO)	
STH ***	-ELEMENT SET INPUT TABLE (TWO DIMENSIONAL); HOOP LOADS VS. HOOP STRAINS FOR MEMBRANE (LBS/INCH VS DIMENSIONLESS RATIO)	
REL	-INPUT TABLE (ONE DIMENSION); RELIEF VALVE OPENING AREA VS TRUNK PRESSURE (SQ.IN VS PSIA)	
ZTR	-INPUT TABLE FOR DEFINITION OF GROUND ELEVATION (SEE FUNCTION TERRA)	

\*\* Due to limitations in the number of Fortran variables permitted in a subroutine argument list, some of the input variables for this component must be input as arguments of an EASY table. See page 152 for a definition of each table argument.

\*\*\* See page 160 for additional information

ELASTIC TRUNK MODEL

TS

INPUTS

QUANTITY NAME	DESCRIPTION	UNITS
ROL,PIT,YAW X,ALT U,V,W PA WCU TCU WTR TTR ANE	-ROLL,PITCH,YAW EULER ANGLES, -X,Z EARTH AXIS POSITIONS -X,Y,Z BODY AXIS LINEAR VELOCITIES, -AMBIENT PRESSURE -SUPPLY AIR FLOW RATE TO CUSHION CAVITY -TEMPERATURE OF WCU AIR -SUPPLY AIR FLOW RATE TO TRUNK -TEMPERATURE OF WTR AIR -NUMBER OF ELEMENTS PER TRUNK SIDE SYMMETRIC MODEL IF ANE.LT.0	DEG FT FT/SEC PSIA LB/MIN DEGR LB/MIN DEGR -----
CDG	-DISCHARGE COEFF. FOR FLOW THROUGH GAP	-----
CDA	-DISCHARGE COEFF. FOR FLOW THROUGH RELIEF VALVE	-----
CD1	-ORIFICE DISCHARGE COEFFICIENT FOR FREE PORTION OF TRUNK	-----
CD2	-ORIFICE DISCHARGE COEFFICIENT FOR TRUNK AREA IN CONTACT WITH THE GROUND	-----
TAU	-TIME CONSTANT FOR TRUNK AND CUSHION VOLUME RATE OF CHANGE	SEC
P,Q,R DMP	-X,Y,Z BODY AXIS ANGULAR VELOCITIES, -DAMPING COEFFICIENT AS FUNCTION OF FLATTENED AREA,	DEG/SEC LB/SEC/ CU IN
EPC	-CONTROL FOR ADDITIONAL PRINTOUT OF ELASTIC TRUNK ELEMENT VARIABLES = 0 NO PRINTOUT = 1 WILL PRINT VALUES EVERY PRINT INTERVAL DURING SIMULATION OR LINEAR ANALYSIS	
VU PTM	-BREAK POINT IN MU-VELOCITY CURVE -MAXIMUM TRUNK PRESSURE USED TO GENERATE MEMBRANE DATA ARRAYS	IN/SEC PSIG
CAV SPB	-EFFECTIVE AREA OF TRUNK-TO-CUSHION VENT -ACTUATION SIGNAL FOR PILLOW BRAKE ELEMENTS = 0 BRAKES OFF = 1 BRAKES FULLY APPLIED.	SQ IN -----

ELASTIC TRUNK MODEL

TS

OUTPUTS

QUANTITY NAME	DESCRIPTION	UNITS
FXT, FYT, FZT	-X, Y, Z AXIS, AXIAL, LATERAL AND VERTICAL FORCE -SUMMATION TERMS	LBS
TXT, TYT, TZT	-X, Y, Z AXIS SUMMATION TERMS FOR ROLL, PITCH -AND YAW MOMENTS	FT-LB
*PT	-TRUNK PRESSURE	PSIA
*VT	-TRUNK VOLUME	CU FT
*PC	-CUSHION PRESSURE	PSIA
*VC	-CUSHION VOLUME	CU FT
WTA	-AIR FLOW RATE, TRUNK TO ATMOSPHERE	LB/MIN
WCA	-AIR FLOW RATE, CUSHION TO ATMOSPHERE	LB/MIN
WTC	-AIR FLOW RATE, TRUNK TO CUSHION	LB/MIN
ARL	-RELEASE VALVE OPENING AREA	SQ IN
CPT	-CPU TIME	SEC

\* STATE VARIABLES

## USER GUIDELINES FOR ELASTIC TRUNK MODEL

Limitations: Maximum number of trunk elements = 25  
Maximum number of unique element sets = 8

Element - a subdivision of the trunk membrane

Element Set - a collection of elements which have identical values for the parameters A, B, LO, , and (see Table ABL)

Input Parameter PTM - The user should input the maximum normal pressure (PSIG) expected rather than the ultimate pressure expected. For occasional pressure spikes, greater than PTM, extrapolation is used.

Excessively large values of PTM may result in non-convergence and program failure during construction of the initial condition variable arrays.

Input Variable SPB - Pillow brake actuation signal. If pillow brake elements are present, the value for SPB must remain within the boundaries:  $0 \leq \text{SPB} \leq 1$ .

SPB=0.	Brakes off
$0 < \text{SPB} < 1$	Linear brake application
SPB=1	Brakes fully actuated

It is recommended that SPB be the output of a transfer function component (i.e. LA, LG, TF) to represent the desired dynamics of pillow actuation.

If no pillow elements are present, SPB will default to zero.

3T

TS

TS Tables

User information for the input of data via TS tables is contained in the subsequent pages. Descriptions for the following tables are listed in alphabetical order:

ABL	PM
BWT	SPH
DM	STH
END	XYZ
IAL	

TABLE NAME: ABL

CARD IMAGES FOR ANALYSIS FILE:

TABLE=ABLTS=k

$A_1, B_1, LO_1, \epsilon_{\phi 1}, \epsilon_{\theta 1}, \nu_1$

$A_2, B_2, LO_2, \epsilon_{\phi 2}, \epsilon_{\theta 2}, \nu_2$

.....

.....

$A_j, B_j, LO_j, \epsilon_{\phi j}, \epsilon_{\theta j}, \nu_j$

NOMENCLATURE

- j - number of unique element data sets ( $j \leq 8$ )
- k -  $=3 \times j$
- A - horizontal distance between attach points (inches)
- B - vertical distance between attach points (inches)  
(negative if outboard attach point is lower)
- LO - meridian length of membrane between attach points in its  
installed, deflated configuration (inches)
- $\epsilon_{\phi}$  - initial meridian strain in the installed deflated  
configuration (dimensionless)
- $\epsilon_{\theta}$  - initial hoop strain in the installed deflated configuration
- $\nu$  - poisson's ratio for membrane material

2T

TS

TABLE NAME: BWT

CARD IMAGES FOR ANALYSIS FILE

TABLE=BWTTS=4

BST, WLT, BSCG, WLCG,

AMODE, ANR, DL, H

NOMENCLATURE

See Model TK for definition of BST, WLT, BSCG, WLCG, AMODE, ANR, DL, H

TS

TABLE NAME: DM

CARD IMAGES FOR ANALYSIS FILE

TABLE=DM TS=n

D<sub>1</sub>, MU<sub>1</sub>, D<sub>2</sub>, MU<sub>2</sub>, D<sub>3</sub>, MU<sub>3</sub>, D<sub>4</sub>, MU<sub>4</sub>,  
D<sub>5</sub>, MU<sub>5</sub>, .....  
.....  
....., D<sub>n</sub>, MU<sub>n</sub>

NOMENCLATURE

- n - number of elements  $n \leq 25$
- D - element width for side elements (inches)  
- element swept angle for end elements (degrees)
- MU - coefficient of friction

TS

TABLE NAME: END

CARD IMAGES FOR ANALYSIS FILE

TABLE=ENDTS=m

$R_1, F_1, R_2, F_2, \dots$

$\dots, R_m, F_m$

NOMENCLATURE

- m - number of unique end data sets
- R - radius to inboard attach point (inches)
- F - factor to account for radial construction of end elements  
= 0, for rectangular construction  
=  $d/L_f$ , for radial construction
- $L_f$  - free length of membrane between inboard and outboard attach points (inches)
- d - distance along meridian free length from inboard attach point to a point which is representative of the meridian load/deflection curve.

TABLE NAME: IAL

CARD IMAGES FOR ANALYSIS FILE

TABLE=IALTS=m

IS<sub>1</sub>, AP<sub>1</sub>, LP<sub>1</sub>, LH<sub>1</sub>, IS<sub>2</sub>, AP<sub>2</sub>, LP<sub>2</sub>, LH<sub>2</sub>,

IS<sub>3</sub>, AP<sub>3</sub>, . . . . .

. . . . .

. . . . ., IS<sub>n</sub>, AP<sub>n</sub>, LP<sub>n</sub>, LH<sub>n</sub>

NOMENCLATURE

m - 2xn

n - number of trunk elements

IS - element set number

AP - orifice area per unit trunk area

LP - distance from outboard attach point to start of perforations  
(measured in membrane free state) inches

LH - width of perforated area (measured in membrane free state)  
inches

TS

TABLE NAME: PM

CARD IMAGES FOR ANALYSIS FILE

TABLE=PM TS=L

IP<sub>1</sub>, MB<sub>1</sub>, HB<sub>1</sub>, kD<sub>1</sub>

IP<sub>2</sub>, MB<sub>2</sub>, HB<sub>2</sub>, kD<sub>2</sub>

.....

.....

IP<sub>N</sub>, MB<sub>N</sub>, HB<sub>N</sub>, kD<sub>N</sub>

NOMENCLATURE

- N - number of pillow type elements. Includes pillow elements and adjacent elements
- L - 2xN
- IP - element number of pillow type element
- MB - coefficient of friction for pillow brake elements when brakes are applied. MB must be set to zero for elements adjacent to pillow brake elements
- HB - pillow height for pillow elements (inches) for adjacent elements, HB represents the maximum gap due to inflation of the pillow element
- kD - factor to account for reduced element width due to inflation of pillow elements. kD applies to pillow AND adjacent elements

$$kD = \frac{D_{\text{inflated}}}{D_{\text{normal}}} \quad 0 < kD \leq 1$$

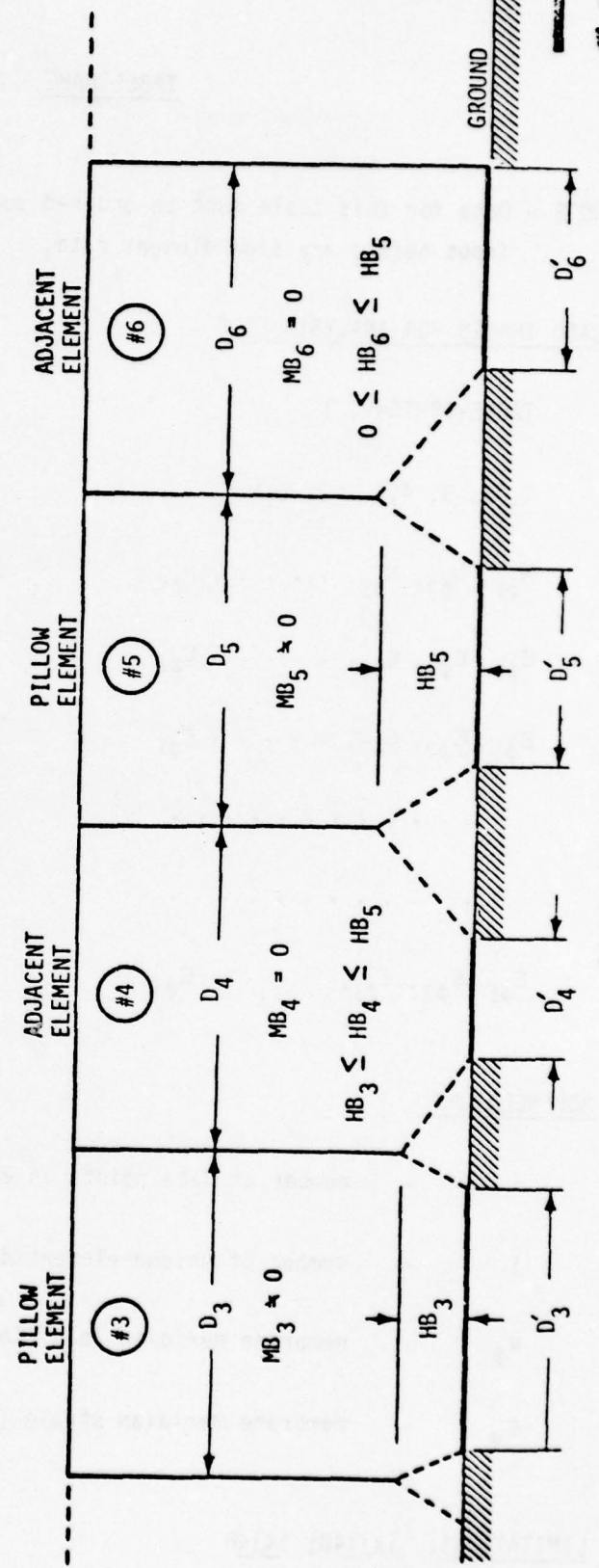
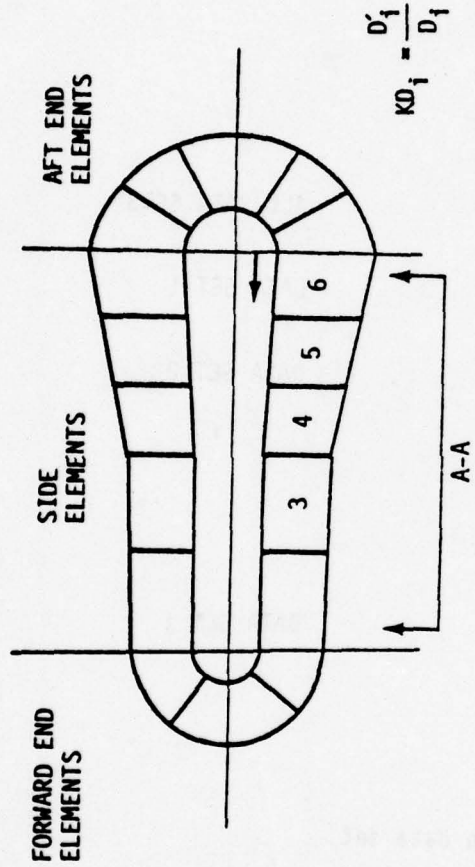

PILLOW ELEMENT SCHEMATIC ILLUSTRATES EFFECTS OF INITIATED PILLOW ELEMENTS

TABLE NAME: SPH

NOTE - Data for this table must be ordered such that all end element data is input before any side element data.

CARD IMAGES FOR ANALYSIS FILE

TABLE=SPHTS=i, j

1, 2, 3, 4, . . . . , j

$N_{\phi 1}, N_{\phi 2}, N_{\phi 3}, \dots, N_{\phi i}$

$\epsilon_{\phi 1}, \epsilon_{\phi 2}, \epsilon_{\phi 3}, \dots, \epsilon_{\phi i}$

$\epsilon_{\phi 1}, \epsilon_{\phi 2}, \epsilon_{\phi 3}, \dots, \epsilon_{\phi i}$

. . . . .

. . . . .

$\epsilon_{\phi 1}, \epsilon_{\phi 2}, \epsilon_{\phi 3}, \dots, \epsilon_{\phi i}$

ALL DATA SETS

DATA SET 1

DATA SET 2

DATA SET j

NOMENCLATURE

i - number of data points in each data set

j - number of unique element data sets

$N_{\phi}$  - membrane meridian load (lb/inch)

$\epsilon_{\phi}$  - membrane meridian strain ( $\Delta L/L$ , dimensionless)

LIMITATIONS:  $i \times j \leq 48; 1 \leq j \leq 8$

2T

TS

TABLE NAME: STH

CARD IMAGES FOR ANALYSIS FILE

TABLE=STHTS=i, j

1, 2, 3, 4, . . . , j

$N_{\theta 1}, N_{\theta 2}, N_{\theta 3}, \dots, N_{\theta i}$

ALL DATA SETS

$\epsilon_{\theta 1}, \epsilon_{\theta 2}, \epsilon_{\theta 3}, \dots, \epsilon_{\theta i}$

DATA SET 1

$\epsilon_{\theta 1}, \epsilon_{\theta 2}, \epsilon_{\theta 3}, \dots, \epsilon_{\theta i}$

DATA SET 2

.....

.....

$\epsilon_{\theta 1}, \epsilon_{\theta 2}, \epsilon_{\theta 3}, \dots, \epsilon_{\theta i}$

DATA SET j

NOMENCLATURE

i - number of data points in each data set

j - number of different element data sets

$N_{\theta}$  - membrand hoop load (lb/inch)

$\epsilon_{\theta}$  - membrane hoop strain ( $\Delta L/L$ , Dimensionless)

LIMITATIONS:  $ixj \leq 48$ ;  $1 \leq j \leq 8$

TABLE NAME: XYZ

CARD IMAGES FOR ANALYSIS FILE

TABLE=XYZTS=m

XA<sub>1</sub>, YA<sub>1</sub>, ZA<sub>1</sub>, BET<sub>1</sub>, XA<sub>2</sub>, YA<sub>2</sub>, ZA<sub>2</sub>, BET<sub>2</sub>,

XA<sub>3</sub>, YA<sub>3</sub>, ZA<sub>3</sub>, BET<sub>3</sub>, . . . . .

. . . . .

. . . . ., XA<sub>n</sub>, YA<sub>n</sub>, ZA<sub>n</sub>, BET<sub>n</sub>

NOMENCLATURE

- m - 2xn
- n - number of trunk elements
- XA - x coordinate of inboard attach point (inches)
- YA - y coordinate of inboard attach point (inches)
- ZA - z coordinate of inboard attach point (inches)
- BET - swept angle of trunk element (degrees)
  - = 0 for a side element
  - ≠ 0 for an end element

TT

TWO DEGREE OF FREEDOM RIGID BODY DYNAMICS (LONGITUDINAL)

INPUT

PHYSICAL QUANTITY NAME	PORT NO.	DESCRIPTION	UNITS
WD TY IYY ROL U		Z BODY AXIS LINEAR ACCELERATION Y BODY AXIS TORQUE Y BODY AXIS MOMENT OF INERTIA EULER ANGLE (BODY TO INERTIAL AXES) X BODY AXIS LINEAR VELOCITY	FT/SEC <sup>2</sup> FT-LBS SLUG-FT <sup>2</sup> DEG FT/SEC

OUTPUT

PHYSICAL QUANTITY NAME	PORT NO.	DESCRIPTION	UNITS
*W *Q *PIT *ALT QD		Z BODY AXIS LINEAR VELOCITY Y BODY AXIS ANGULAR RATE EULER ANGLE, BODY TO INERTIAL AXIS VERTICAL ALTITUDE FROM SEA LEVEL Y BODY AXIS ANGULAR ACCELERATION	FT/SEC DEG/SEC DEG FT DEG/SEC <sup>2</sup>

EQUATIONS:

$$\begin{aligned} \dot{W} &= WD \\ \hat{Q} * IYY &= TY \\ \dot{PIT} &= Q * CR \\ ALT &= SP * U - CP * CR * W \\ SP &= \sin(PIT), CP = \cos(PIT), CR = \cos(ROL) \end{aligned}$$

\* State Variables

References: Listings -- Volume II, Section 4.3.6  
Analysis -- Volume I, Section 2.4.6

# TRANSFER FUNCTION

TZ

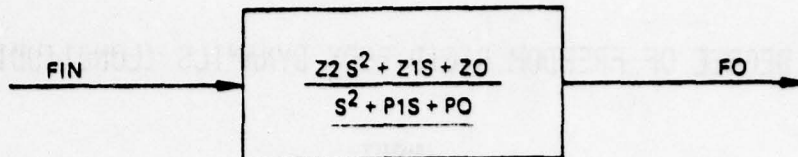

## INPUT

PHYSICAL QUANTITY NAME	PORT NO.	DESCRIPTION	UNITS
FIN		Input quantity	
Z0		Numerator coefficient	
Z1		Numerator coefficient	
Z2		Numerator coefficient	
P0		Denominator coefficient	
P1		Denominator coefficient	

## OUTPUT

PHYSICAL QUANTITY NAME	PORT NO.	DESCRIPTION	UNITS
* X1		Intermediate state (State)	
* X2		Intermediate state (State)	
FO		Output quantity (Variable)	

**EQUATIONS:**

$$\dot{X}_1 = Z_0 \cdot FIN - P_0 \cdot FO$$

$$\dot{X}_2 = X_1 + Z_1 \cdot FIN - P_1 \cdot FO$$

$$FO = X_2 + Z_2 \cdot FIN$$

NOTE: d.c. gain =  $\frac{Z_0}{P_0}$  infinite gain = Z2

\* This output quantity is a state.

References: Listing -- Volume II, Section 3.4.6

AERODYNAMIC VARIABLES FROM STATES

VA

INPUT

PHYSICAL QUANTITY NAME	PORT NO.	DESCRIPTION	UNITS
U,V,W P,Q,R ALT PIT, ROL ID	1	X,Y,Z BODY AXIS LINEAR VELOCITIES X,Y,Z BODY AXIS ANGULAR RATES ALTITUDE ABOVE SEA LEVEL PITCH AND ROLL, EARTH TO BODY AXIS ANGLES INDICATOR FUNCTION FOR AERO COMPONENTS 0 = BODY AXIS, DIMENSIONAL 1 = BODY AXIS, NON-DIMENSIONAL 2 = STABILITY AXIS, DIMENSIONAL 3 = STABILITY AXIS, NON-DIMENSIONAL	FT/SEC DEG/SEC FT DEG ---
VS ALS* S UW,VW,WW*		STEADY STATE (TRIM) AIRSPEED STEADY STATE (TRIM) ANGLE OF ATTACK REFERENCE AREA X,Y,Z BODY AXIS WIND VELOCITIES	FT/SEC DEG FT**2 FT/SEC
PW,QW,RW* IDG	1	X,Y,Z BODY AXIS WIND ANGULAR RATES INDICATOR FUNCTION FOR DEGREES OF FREEDOM (DØF) 2 = TWO DØF LINGITUDINAL (S,Q) 3 = THREE DØF LONGI. (U,W,Q) 4 = FOUR DØF LAT (V,P,R) + LONGI. (U) 5 = THREE DØF LATERAL (V,P,R) 6 = SIX DØF (U,V,W,P,Q,R)	DEG/SEC

OUTPUT

PHYSICAL QUANTITY NAME	PORT NO.	DESCRIPTION	UNITS
UO,VO,WØ PO,QØ,RØ ID	2	X,Y,Z BODY AXIS VELOCITIES INCLUDING WIND X,Y,Z BODY AXIS ANGULAR RATES WITH WIND INDICATOR FUNCTION = ID1	FT/SEC DEG/SEC
QW, RW CAL,SAL AL, ALP VT BE WP, UP	2	Q AND R ANGULAR RATE GUSTS DIRECTION COSINES FOR STABILITY AND BODY AXES ANGLE OF ATTACK IN BODY AND STABILITY AXES TRUE AIRSPEED SIDESLIP ANGLE Z AND X STABILITY AXIS VELOCITIES (DIMENSIONAL) Z AND X PERTURBATION VELOCITIES (NON-DIMEN.)	DEG/SEC DEG FT/SEC DEG FT/SEC
EU,EV,EW		X,Y,Z BODY AXIS ACCEL. TERMS FOR U,V,W SOLUTIONS	FT/SEC <sup>2</sup>
SIG QC QS MAC		STANDARD ATMOSPHERE AIR DENSITY RATIO COMPRESSIBLE DYNAMIC PRESSURE DYNAMIC PRESSURE TIMES REFERENCE AREA MACH NUMBER	LBS/FT <sup>2</sup> LBS

\* Default values = 0

VA

AERODYNAMIC VARIABLE EQUATIONS

$$\begin{aligned} \text{CAL} &= \begin{pmatrix} \text{COS(ALS)} & \text{ID} = 2,3 \\ 1 & \text{ID} = 0,1 \end{pmatrix} \\ \text{SAL} &= \begin{pmatrix} \text{SIN(ALS)} & \text{ID} = 2,3 \\ 0 & \text{ID} = 0,1 \end{pmatrix} \end{aligned}$$

$$\begin{aligned} \text{UO} &= \text{U} - \text{UW} \\ \text{VO} &= \text{V} - \text{VW} \\ \text{WO} &= \text{W} - \text{WW} \end{aligned}$$

$$\begin{aligned} \text{PO} &= (\text{P} + \text{PW}) \cdot \text{CAL} + (\text{R} + \text{RW}) \cdot \text{SAL} \\ \text{QO} &= \text{Q} + \text{QW} \\ \text{RO} &= (\text{R} + \text{RW}) \cdot \text{CAL} - (\text{P} + \text{PW}) \cdot \text{SAL} \end{aligned}$$

$$\text{AL} = \text{TAN}^{-1}(\text{WO}/\text{UO})$$

$$\text{ALP} = \text{AL} - \text{ALS}$$

$$\text{VT} = (\text{UO}^2 + \text{VO}^2 + \text{WO}^2)^{1/2}$$

$$\text{BE} = \text{SIN}^{-1}(\text{VO}/\text{VT})$$

$$\text{WP} = \text{WO} \cdot \text{CAL} - \text{UO} \cdot \text{SAL}$$

$$\text{UP} = \begin{pmatrix} \text{UO} \cdot \text{CAL} + \text{WO} \cdot \text{SAL} & \text{ID} = 0,2 \\ (\text{UO} - \text{VS} \cdot \text{COS(ALS)})/\text{VS} & \text{ID} = 1 \\ (\text{UO} \cdot \text{CAL} + \text{WO} \cdot \text{SAL} - \text{VS})/\text{VS} & \text{ID} = 3 \end{pmatrix}$$

$$\text{EU} = -\hat{\text{Q}} \cdot \text{W} + \hat{\text{R}} \cdot \text{V} - \text{G} \cdot \text{SIN(PIT)}$$

$$\text{EV} = -\hat{\text{R}} \cdot \text{U} + \hat{\text{P}} \cdot \text{W} + \text{G} \cdot \text{COS(PIT)} \cdot \text{SIN(ROL)}$$

$$\text{EW} = -\hat{\text{P}} \cdot \text{V} + \hat{\text{Q}} \cdot \text{U} + \text{G} \cdot \text{COS(PIT)} \cdot \text{COS(ROL)}$$

where  $\hat{\text{P}} = \text{P} \cdot \pi/180$  ,  $\hat{\text{Q}} = \text{Q} \cdot \pi/180$  ,  $\hat{\text{R}} = \text{R} \cdot \pi/180$ .

$\text{SIG} = \text{SIG(ALT)}$  AND  $\text{A} = \text{A(ALT)}$  OBTAINED BY TABLE LOOKUP

$$\text{DPS} = \frac{1}{2} \text{PO} \cdot \text{SIG} \cdot (\text{VT})^2$$

$$\text{QS} = \text{DPS} \cdot \text{S}$$

$$\text{MAC} = \text{VT}/\text{A}$$

$$\text{QC} = \begin{pmatrix} \text{DPS} \cdot (1 + (1 + (1 + \text{MAC}^2/40) \cdot \text{MAC}^2/10) \cdot \text{MAC}^2/4) & \text{MAC} \leq 1 \\ \text{DPS} \cdot (1.839 - .772/\text{MAC}^2 = .164/\text{MAC}^4 + .035/\text{MAC}^6) & \text{MAC} > 1 \end{pmatrix}$$

References: Listing -- Volume II, Section 4.3.7  
 Analysis -- Volume I, Section 2.4.7

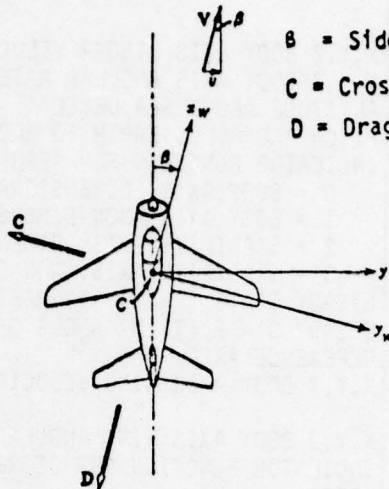

$\beta$  = Sideslip angle  
 C = Cross-wind vector  
 D = Drag vector

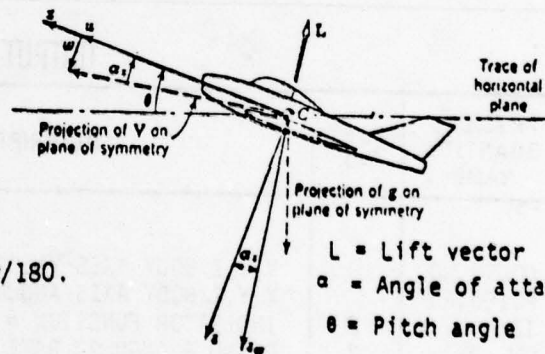

L = Lift vector  
 $\alpha$  = Angle of attack  
 $\theta$  = Pitch angle

# WS

## STEADY OR SHEAR WIND MODEL

### INPUT

PHYSICAL QUANTITY NAME	PORT NO.	DESCRIPTION	UNITS
TWS		TABULAR DATA: WIND SHEAR FACTOR VS AIRPLANE C.G. ALTITUDE	---
WK WAN		WIND MAGNITUDE AT 50 FEET (TOWER) ANGLE BETWEEN WIND VECTOR AND RUNWAY CENTERLINE.	FT/SEC DEG
ALT PIT IND		AIRPLANE C.G. ALTITUDE PITCH ANGLE EARTH TO BODY INDICATOR FOR STEADY OR SHEAR WIND 0 = SHEAR WIND (TABLE LOOKUP USED) 1 = STEADY WIND, FACTOR = 1.0	FT DEG ---

### OUTPUT

PHYSICAL QUANTITY NAME	PORT NO.	DESCRIPTION	UNITS
UWS VWS WWS		X BODY AXIS STEADY OR SHEAR WIND Y BODY AXIS STEADY/SHEAR WIND Z BODY AXIS STEADY/SHEAR WIND	FT/SEC FT/SEC FT/SEC

#### EQUATION:

```

MF = TBLU1(ALT,TWS)    if IND = 0
MF = 1.                if IND = 1
WKN = -WK*MF*COS(WAN*RPD)
WKE = WK*MF*SIN(WAN*RPD)
UWS = WKN*COS(PIT*RPD)
VWS = WKE
WWS = -WKN*SIN(PIT*RPD)          RPD = Radians/Deg
  
```

References: Listing -- Volume II, Section 4.5.2  
Analysis -- Volume I, Section 2.5.2

## STATIC TRANSFORMATION OF ANGULAR RATES

XP

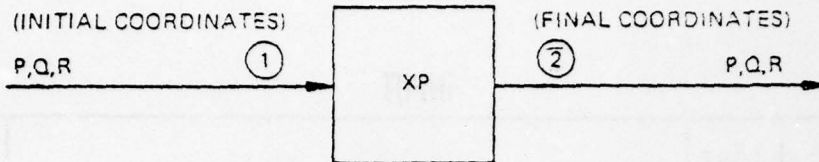

### INPUT

PHYSICAL QUANTITY NAME	PORT NO.	DESCRIPTION	UNITS
P,Q,R	1	Input angular rates-initial coordinates	rad/sec
TM		3x3 transformation matrix	

### OUTPUT

PHYSICAL QUANTITY NAME	PORT NO.	DESCRIPTION	UNITS
P,Q,R	2	Output angular rates-final coordinates	rad/sec

#### EQUATIONS:

$$P_2 = P_1 \cdot TM(1,1) + Q_1 \cdot TM(1,2) + R_1 \cdot TM(1,3)$$

$$Q_2 = P_1 \cdot TM(2,1) + Q_1 \cdot TM(2,2) + R_1 \cdot TM(2,3)$$

$$R_2 = P_1 \cdot TM(3,1) + Q_1 \cdot TM(3,2) + R_1 \cdot TM(3,3)$$

#### ASSUMPTIONS:

TM contains the direction cosines required to transform from the initial coordinate system to the final coordinate system. TM is input as the dependent variable array of a two dimensional table.

References: Listing -- Volume II, Section 3.5.21

# STATIC TRANSFORMATION OF TORQUES

# XT

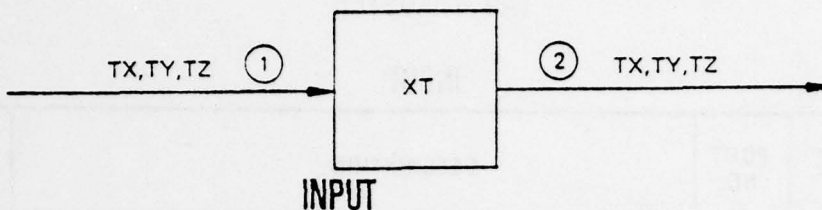

PHYSICAL QUANTITY NAME	PORT NO.	DESCRIPTION	UNITS
TX, TY, TZ TM	1	Input torques - initial coordinates Table of direction cosines	FT-LBS

## OUTPUT

PHYSICAL QUANTITY NAME	PORT NO.	DESCRIPTION	UNITS
TX, TY, TZ	2	Output torques - final coordinates	FT-LBS

### EQUATIONS:

$$TX_2 = TX_1 * TM(1,1) + TY_1 * TM(1,2) + TZ_1 * TM(1,3)$$

$$TY_2 = TX_1 * TM(2,1) + TY_1 * TM(2,2) + TZ_1 * TM(2,3)$$

$$TZ_2 = TX_1 * TM(3,1) + TY_1 * TM(3,2) + TZ_1 * TM(3,3)$$

### ASSUMPTIONS:

TM contains the direction cosines required to transform from the initial coordinate system to the final coordinate system. TM is input as the dependent variable array of a two dimensional table.

References: Listing -- Volume II, Section 3.5.22

YC

YAW THRUSTER

INPUT

PHYSICAL QUANTITY NAME	PORT NO.	DESCRIPTION	UNITS
ED		ENGINE DEPENDENCE INDICATOR 0 = NO 1 = YES	---
TM		THRUSTER MAXIMUM FORCE FOR ENGINE-INDEPENDENT SYSTEM (i.e. ED = 0)	LBS
ST		SLOPE FOR VECTORED THRUST AS FUNCTION OF ENGINE THRUST	---
SR		SLOPE OF ENGINE THRUST REDUCTION AS FUNCTION OF VECTORED THRUST	---
C1		SATURATION FUNCTION SLOPE	---
C2		SATURATION SLOPE	---
SIG		AIRCRAFT CONTROL SYSTEM SIGNAL TO THRUSTER	---
GA		FIRST ORDER LAG GAIN	---
TC		FIRST ORDER LAG TIME CONSTANT	SEC
TH		ENGINE THRUST	LBS
XA		THRUSTER YAW MOMENT ARM	FT
ZA		THRUSTER ROLL MOMENT ARM	FT

OUTPUT

PHYSICAL QUANTITY NAME	PORT NO.	DESCRIPTION	UNITS
*FX		ENGINE THRUST REDUCTION	LBS
FY		VECTORED THRUST SIDE FORCE	LBS
TX		ROLL MOMENT DUE TO THRUSTER	FT-LBS
TZ		YAW MOMENT DUE TO THRUSTER	FT-LBS

\* State variable

References: Listing -- Volume II, Section 4.4.3

YC

YAW THRUSTER

EQUATIONS:

TVA = TM            if ED = 0.  
TVA = ST\*TH        if ED = 1.  
C3 = TVA/C1  
C6 = -C3  
C4 = C1  
C5 = C2  
CALL SA(FY,SIG,C1. . . . . C6)  
FR = -SR\*ABS(FY)        }  
FX = (FR\*GA-FX)/TC     }        if ED = 1  
TX = FY\*ZA  
TZ = FY\*XA

## SECTION IV

### DYNAMIC ANALYSIS

The EASY Analysis program allows several different, dynamic, static, linear, or nonlinear analysis techniques to be brought to bear on the nonlinear dynamic system model generated by the EASY Model Generation program. An abridged description of the data requirements, and the analytical methods available in the analysis program are given in Sections 4.1 through 4.14. An alphabetical index of the analysis program commands is given in Appendix B. For a description of the techniques and numerical methods, see reference 2 Section 4.

In addition to these analysis techniques, optimal linear controllers based on linear optimal regulator and Kalman filter theory can be synthesized by the program. The performance of such optimal controllers when operating with the nonlinear system can be analyzed using any of the analysis techniques.

#### 4.1 Model Input Data

A dynamic system model requires that the values of numerous model parameters, tables and initial conditions, be provided to complete the model description. Sections 4.1.1, 4.1.2 and 4.2 describe the methods used to specify parameter values, tables, and initial conditions. This input data must be specified before any analysis commands, described in Sections 4.4 through 4.12, are issued.

##### 4.1.1 Scalar Data

#### PARAMETER VALUES (Default values = .99999)

This program command allows the numeric values of parameters to be loaded into the system model. The PARAMETER VALUES command precedes one or more parameter names with each parameter name followed by its numeric value. Each name and its value are input in a free field format, separated by one of the standard delimiter symbols (see Table 1). This command is used to specify the values

of all system model parameters at the beginning of an analysis. It may also be used at any point between analyses to modify the value of one or more model parameters. A default value of .99999 is provided by the EASY Model Generation program for all parameters not so specified.

Example 4.1:

```
PARAMETER VALUES = MA10L = 87.21, CDGTK = .395,  
AK1FS=3, EPCTK=1, FC DU=1, VC TK=15.E5 .....
```

#### 4.1.2 Tabular Data

The tables required by an EASY generated model are specified in the Input Requirements List. These tables may have either one or two independent variables. All tabular data are input in a free field format with each item separated by one of the standard delimiters (see Table 1). Tables may be modified between analyses by loading new values. The data items required for each table are placed on cards as follows:

Card 1	TABLE	table name	NX	NZ
Card 2	Z	table values		
Card 3	X	table values		
Card 4	Y	table values		

where: table name - The seven character table name generated by the EASY Model Generation program.

- NX - The number of points in the primary independent variable table.
- NZ - The number of points in the secondary independent variable table.
- Z table - Table of NZ secondary independent variable values.
- X table - Table of NX primary independent table values.
- Y table - 1 or NZ tables of NX dependent variable values. (i.e. NZ\*NX values)

Each table must start with a new card. As many cards as required may be used for the Z, X and Y values. A copy of all tabular input data is printed as it is interpreted from data cards. The following example shows the data cards for a one and a two independent variable table.

Example 4.2:

Card 1 TABLE, TAB-ONE, 10  
Card 2 1, 2, 3, 4, 5, 6, 7, 8, 9, 10  
Card 3 11, 12, 13, 14, 15, 16, 17, 18, 19, 110  
Card 4 TABLE, TAB-TWO, 5, 4  
Card 5 10.3, 20.4, 30.5, 40.6  
Card 6 1, 2, 3, 4, 5  
Card 7 11, 12, 13, 14, 15  
Card 8 21, 22, 23, 24, 25  
Card 9 31, 32, 33, 34, 35  
Card 10 41, 42, 43, 44, 45

The printout of these tables would be:

```
          TABLE TAB-ONE
    PRIMARY INDEPENDENT VARIABLE TABLE
1.000  2.000  3.000  4.000  5.000  6.000  7.000  8.000  9.000  10.00

    DEPENDENT VARIABLE TABLE
11.00  12.00  13.00  14.00  15.00  16.00  17.00  18.00  19.00  110.00

          TABLE TAB-TWO
    SECONDARY INDEPENDENT VARIABLE TABLE
    10.30      20.40      30.50      40.60

    PRIMARY INDEPENDENT VARIABLE TABLE
1.000      2.000      3.000      4.000      5.000

    DEPENDENT VARIABLE TABLE
11.00      12.00      13.00      14.00      15.00
21.00      22.00      23.00      24.00      25.00
31.00      32.00      33.00      34.00      35.00
41.00      42.00      43.00      44.00      45.00
```

4.2 Initial Condition, Error, and Integration Controls

```
          INITIAL CONDITIONS (Default value = 0)
          ERROR CONTROLS   (Default value = 0.001)
          INT CONTROLS     (Default value = 1.0)
```

These program commands may be used to specify initial condition values, integrator error controls, or the integrator status, (either active (=1) or frozen (= 0)) for the state variables in the system model. Default values of 0. for initial conditions, 0.001 for error controls, and 1 for integration status are furnished by the EASY Analysis program. However, it is strongly recommended that values appropriate to the particular system model be furnished for the initial conditions and error controls.

The values input by the INITIAL CONDITIONS command, are stored in the XIC vector (see Section 4.3). The current XIC values will be used for the initial conditions for all EASY analyses.

Example 4.3:

```
INITIAL CONDITIONS = W SG = 50, PITSG = 2.  
ERROR CONTROLS = W SG = .1, PITSG = .01  
INT CONTROLS = W SG = 0, PITSG = 1, ALTSG = 1
```

```
ALL STATES (Default Condition)  
NO STATES
```

These program commands activate (ALL STATES) or freeze (NO STATES) all system integrators. These commands are normally used together with the INT CONTROLS command to specify the desired integrator configuration.

```
INITIAL TIME (Default = 0.)
```

This program command allows the initial value of time to be specified. The default value of initial time is zero. The INITIAL TIME command is used with models that contain time dependent features where it may be desirable to have time at the beginning of a simulation run or during a steady state analysis be some value other than zero.

#### 4.3 Initial Condition Storage Commands

```
XIC-X  
XIC-XIC1  
XIC-XIC2  
XIC-XIC3  
XIC1-XIC  
XIC2-XIC  
XIC3-XIC
```

These program commands are used to transfer data from the current state vector, X, to the initial condition vector, XIC, and between the XIC vector and three auxiliary initial condition vectors XIC1, XIC2, XIC3. These seven initial condition storage commands are the only combinations of X, XIC, etc. the EASY analysis program can recognize.

Example 4.4:

XIC1-XIC, XIC-X, XIC2-XIC

The three program commands shown above would take the initial condition vector, XIC, and store it in vector XIC1; then transfer the current state, X, into XIC; and then store that value of XIC in XIC2.

#### 4.4 Simulation Commands

##### SIMULATE

This program command initiates a time history simulation of the system. Associated with this command are the program values:

		<u>Default Values</u>
TINC	= time increment, seconds	0.1
TMAX	= duration of the simulation run, seconds	1.0
INT MODE	= integrator mode control	6
OUTRATE	= output rate	1
PRATE	= print rate	1
PRINT CONTROL	= print control variable	3

These program commands specify the integration time increment, duration of simulation run, the integration mode, the simulation output rate, the printing rate, and the quantity of printing, at each point in time. These quantities must be specified before the first issuance of the SIMULATE command.

The integration mode control, INT MODE, specifies one of seven different numerical integration methods listed in Table 2. The default value of INT MODE is 6.

TABLE 2 INTEGRATION METHOD SELECTION

INT MODE	METHODS	
1	DIFSUB:	Original Gear integrator with variable step and variable order.
2	NRKVS:	The improved Runge-Kutta variable step integrator.
3	HEUNS:	Fixed step explicit method of order two.
4	EULER:	Fixed step explicit method of order one.
5	ADAMS:	Automatic step-size/order selection methods using Adams-Bashforth predictor/Adams-Moulton corrector pairs of orders 2 through 12.
6	STIFF GEAR:	The backward differentiation (stiffly stable) variable order variable step size.
7	RUNGE-KUTTA:	Fourth order fixed step.

The time increment, TINC, provides the integrator time step size, in seconds, for the fixed step integrators. TINC also provides the report interval for which data will be available for printing or plotting. The default value for TINC is 0.1.

The duration of a simulation calculation in seconds, is specified by the TMAX parameter. The default value of TMAX is 1.

The output rate parameter, OUTRATE, determines the sampling rate at which simulation data is added to plots. Thus, if OUTRATE is set equal to 10, data will be plotted every 10th time increment, TINC. This feature is normally used only when a fixed step size integrator is specified. With such an integrator, the time increment is usually quite small, and excessive plotted

output would be generated if it were not for the sampling feature provided by the OUTRATE parameter. The default value of OUTRATE is 1. OUTRATE should only be set to positive integer values.

The number of data samples plotted for a simulation analysis is thus given by:

$$\text{No. of Plotted Samples} = \frac{\text{TMAX}}{\text{TINC} * \text{OUTRATE}} + 1$$

For most simulation operation, the plotted output is the primary output and no line printer output is used. However, for diagnosing problems in a simulation, the line printer options provided by the PRINT CONTROL parameter allow large amounts of detailed information about the simulated system to be obtained.

The value of the PRINT CONTROL parameter controls the quantity of data printed at each print report interval as shown in Table 3. Options 1 through 4 give "snap-shots" of all states, rates, variables, and parameters of the system model at a particular point in time. Option 5 provides tabular lists of up to 10 specified quantities. The default value for PRINT CONTROL is 3.

TABLE 3 PRINT CONTROL VALUES

PRINT CONTROL	Resultant Lineprinter Output.
0 or 1	All states, rates, and time
2	All states, rates, variables, and time
3	All states, rates, variables, and parameters at time = 0
4	All states, rates, variables, and parameters
5	Time and the quantities specified via PRINT VARIABLES command
6	All states, rates, variables, and parameters at each STEADY STATE iteration
7	All states, rates, variables, parameters and system Jacobian matrix at each STEADY STATE iteration.

The PRATE parameter determines the sampling rate at which the simulation data specified by the PRINT CONTROL parameter is presented on the lineprinter. Thus, if PRATE is set equal to 5, data will be printed on the lineprinter every 5th time it is added to the output plots. The rate of output to the lineprinter can never be greater than that to the plots. The default value of PRATE is 1. PRATE should only be set to positive integer values.

The number of data samples printed for a simulation analysis is thus given by:

$$\text{No. of Printed Samples} = \frac{\text{TMAX}}{\text{TINC} * \text{OUTRATE} * \text{PRATE}} + 1$$

#### Example 4.5

```
PRINT CONTROL = 2, TINC = .01, TMAX = 10.,  
INT MODE = 2, OUTRATE = 10, PRATE = 10, SIMULATE
```

In the example, the NRKVS Runge-Kutta integration method would be used with a maximum step size of .01 second. The simulation would run for 10 seconds. Plotted output would occur every .1 second (10\* .01), and printed output would occur every 1. second (10\* 10\* .01).

#### PRINT VARIABLES

This program command allows up to ten variables to be specified for printing under option 5 of the PRINT CONTROL. This command is followed by from one to ten state, rate, or variable names separated by delimiters. This command wipes out all previously stored PRINT VARIABLES names.

#### Example 4.6

```
PRINT VARIABLES = P1 DE1, P1 DE2, W1 DE2
```

#### 4.5 Plot Designation Commands

PLOT ON  
PLOT OFF (Default Condition)  
PRINTER PLOTS

These program commands allow the plotted output to be turned on or off. It is therefore necessary to include the PLOT ON or PRINTER PLOTS command before requesting any analysis from which plots are desired. The PLOT ON command turns on the plotting capabilities which produce off-line SC4020 plots. The PRINTER PLOTS command turns on the plotting capabilities which produce line printer plots. Only time histories and steady state parameter scan graphics are available with line printer plots. Line printer plots do not have the MANUAL SCALES option (discussed later in the section).

PLOT ALL TABLES  
PLOT TABLES

These commands plot tables input by the program user. PLOT ALL TABLES will cause all the input tables to be plotted, whereas PLOT TABLES will plot only those tables listed after the command. These commands are very useful for checking input data.

DISPLAY1  
DISPLAY2  
DISPLAY3  
DISPLAY4  
DISPLAY5  
DISPLAY6

These program commands are used to define the quantities to be plotted for simulation or steady state calculations. These commands must be issued before

the simulation or steady state analysis is requested. From one to five plots may be specified per display. When off-line plots are requested, each display command produces one full page of graphs. Printer plots ignore the display designation and put each graph on a separate computer output page.

Each plot is specified by stating the dependent variable and the independent variable separated by the letters VS. If desired, the independent and dependent axis scale ranges can also be specified for off-line plots. The independent scale range is specified by the word X RANGE followed by the minimum and maximum values for this scale. The dependent scale similarly is specified by the word Y RANGE. If scale ranges are not specified, values will be used that span the given data.

Example 4.7:

```
DISPLAY1
PT TK, VS, TIME, YRANGE = -2,4
ALTSG, VS, TIME, YRANGE = -.5,.5
PC TK, VS, TIME, YRANGE = 0,60
DISPLAY2
WTCTK, VS, TIME, YRANGE = -20,20
VC TK, VS, TIME, YRANGE = -15,15
VT TK, VS, TIME, YRANGE = -100,100
PITSG, VS, TIME, YRANGE = -5,5
DISPLAY3
ALTSG, VS, PT TK, X RANGE = -1,5, YRANGE = 300,500
```

Automatic or manual scales are selected by the commands SI MANUAL SCALES or SI AUTO SCALES for simulation plots and SS MANUAL SCALES or SS AUTO SCALES for steady state plots.

SI MANUAL SCALES  
SI AUTO SCALES (Default Condition)

The SI MANUAL SCALES command allows the off-line plotted output requested by the DISPLAY commands to be plotted on manual scales specified by the Y RANGE

and X RANGE commands. The SI AUTO SCALES command can be used to return plotting to the automatic scaling mode. Auto scales are selected to span each plotted quantity. The auto scale option is the default used until manual scales are requested.

#### SS MANUAL SCALES SS AUTO SCALES (Default Condition)

The SS MANUAL SCALES command allows the off-line plotted output requested by the DISPLAY commands to be plotted on manual scales specified by the Y RANGE and X RANGE commands. The SS AUTO SCALES command can be used to return plotting to the automatic scaling mode. Auto scales are selected to span each plotted quantity. The auto scale option is the default used until manual scales are requested.

#### PLOT ID TITLE

The PLOT ID program command allows an identification label to be placed as the first page of plotted output. Up to 48 characters may follow the delimiter that follows the PLOT ID command. This command can be used to place mailing information on the plotted output.

The TITLE command allows a title to be placed on all plotted output. Up to 74 characters may follow the delimiter that follows the TITLE command. The TITLE command may be changed before each analysis. Once defined, the title remains in effect until a new title is entered.

Example 4.8:

```
PLOT ID = M. K. WAHI      **M/S 47-03 **  
TITLE   = LONGITUDINAL TRIM--FREE AIRPLANE
```

AD-A081 160

BOEING AEROSPACE CO SEATTLE WA BOEING MILITARY AIRPL--ETC F/G 9/2  
EASY-ACIS DYNAMIC ANALYSIS. USER'S MANUAL.(U)

SEP 79 M K WAHI, G S DULEBA, P R PERKINS

F33615-77-C-3054

UNCLASSIFIED

AFFDL-TR-79-3106

NL

3 of 4

AD  
A081160

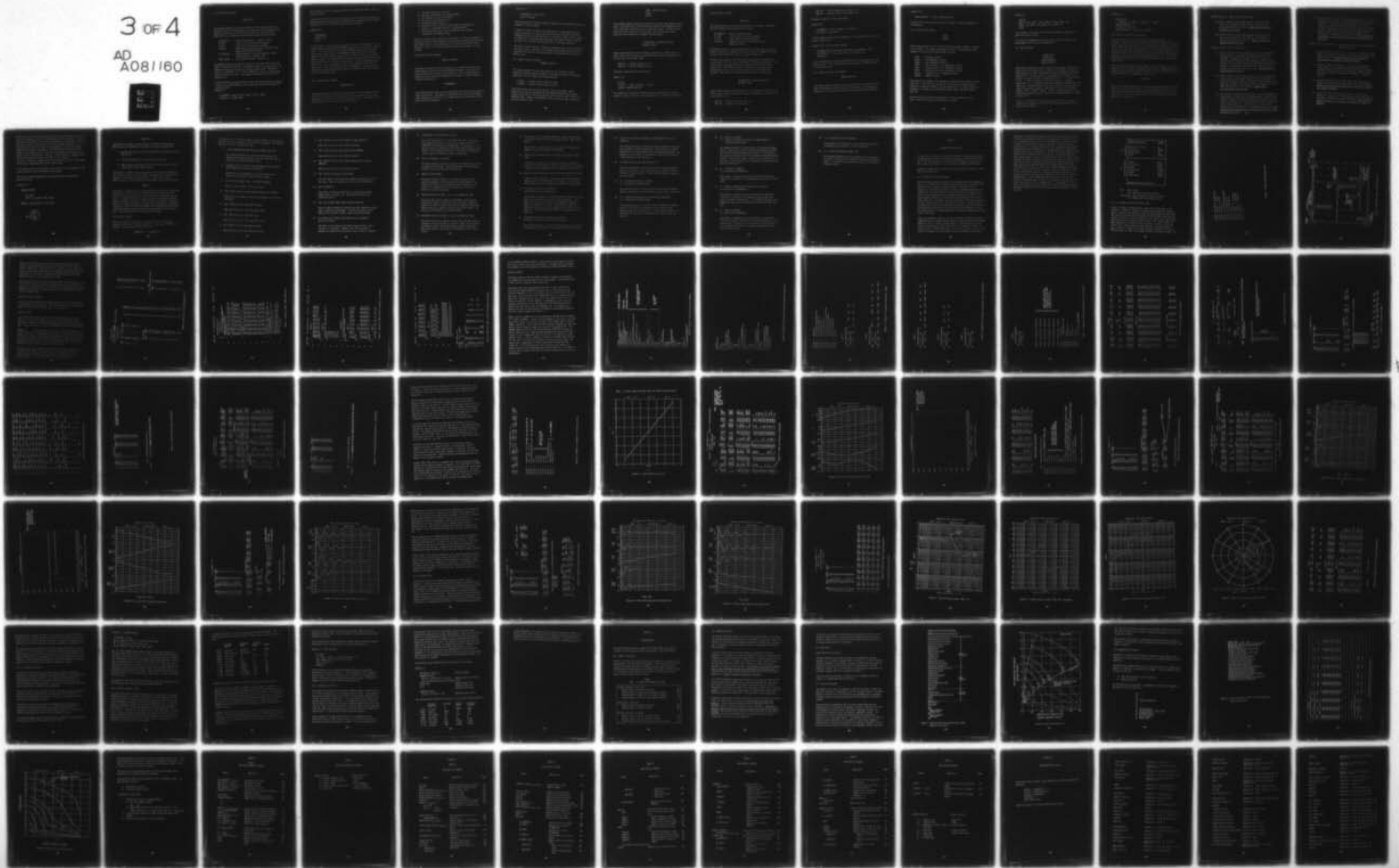

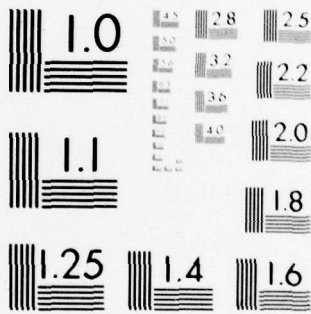

MICROCOPY RESOLUTION TEST CHART  
NATIONAL BUREAU OF STANDARDS-1963-A

## 4.6 Steady State Commands

### STEADY STATE

This program command initiates the calculation of the system steady state. The EASY steady state algorithm defines a steady state to exist whenever the magnitudes of the rates of all the active states are less than 0.0001.

Associated with this command are the following program names and values:

SS PARAMETER	=	steady state parameter. (Default = blank)
SS START	=	initial value of steady state parameter.
SS STOP	=	final value of steady state parameter.
SS POINTS	=	number of values the steady state parameter takes going from SS START to SS STOP.
SS ITERATIONS	=	maximum number of iterations allowed per steady state calculation. (Default = 30)
PRINT CONTROL	=	print control variable. (Default = 0)

SS PARAMETER specifies the parameter which will be scanned from the value SS START to SS STOP for SS POINTS. SS ITERATIONS specifies an upper limit on the number of iterations to be used to calculate a steady state. The default value of SS ITERATIONS is 30. If the SS PARAMETER is blank, a single steady state calculation will occur. The steady state parameter can be any valid parameter name.

The PRINT CONTROL parameter provides all the print control functions described in Section 4.4. PRINT CONTROL 6 and 7, may be used to track the steady state iteration process.

Example 4.9:

```
SS PARAMETER = RPM, SS START = 19000, SS STOP = 16000  
SS POINTS = 7, STEADY STATE
```

This example will scan the parameter RPM over the range from 19000 to 16000 at seven RPM values.

If printer or off-line plots of the steady state scan are desired, these plots should be defined using the DISPLAY command and the appropriate plotter output turned on prior to initiating the steady state calculations.

Example 4.10:

```
SS PARAMETER  
STEADY STATE  
XIC-X
```

In this example, the steady state parameter is set to a blank phrase. This is accomplished by placing the SS PARAMETER program name at the end of a command line. If it is desired to follow the SS PARAMETER program name with other instructions, then the form: SS PARAMETER = NONE may be used. In either case, this causes a single steady state calculation to occur at the current operating point. At the end of the blank phrase steady state calculation, the system stability will be checked to assure that a stable steady state exists. The results of this calculation are then loaded into the initial condition vector, XIC. The initial default value of SS PARAMETER is a blank phrase so that single steady state calculations will be performed, until this parameter is set to a non blank name.

#### 4.7 Linear Analysis Commands

##### LINEAR ANALYSIS

This program command initiates the calculation of a linear approximation to the given nonlinear model at the operating point specified by XIC and then calculates the eigenvalues of this linear approximation. A printout of the following quantities is generated by this command:

1. The state operating point (XIC)
2. The state perturbation size (ERROR CONTROL)
3. The integrator status (INT CONTROL)
4. The rates at the operating point
5. The system stability matrix
6. A measure of the linearity of each element of the stability matrix if a nonlinear condition is detected (RATIO).
7. The system eigenvalues, real and imaginary parts, natural frequencies, and damping ratios.

RATIO is a measure of the linearity of the system. It lists all elements in the stability matrix which change more than 10% from a second stability matrix calculated by using a state perturbation size vector one half the original perturbation vector. The ratio of these stability matrix elements are also printed.

#### 4.8 Stability Margin Commands

##### STABILITY MARGINS

This program command initiates the calculation of the stability margins for those parameters specified by the SM PARAMETERS command. The maximum and minimum values that each specified parameter can take for stable system operation and the oscillation frequencies that result if either boundary is violated are determined.

##### SM PARAMETERS

This program command allows up to ten parameters to be specified for stability margin calculations. The command is followed by from one to ten parameter names separated by delimiters. This command destroys all previously stored stability margin parameters.

Example 4.11:

```
SM PARAMETERS = GK1TC, GK2TC  
STABILITY MARGINS
```

These commands would cause the stability margins to be calculated for the two parameters, GK1TC and GK2TC.

A summary of stability margins and frequencies is printed and the nominal system eigenvalues, and the system eigenvalues with each stability margin parameter set equal to zero are given. If no upper or lower stability margin is located for a stability margin parameter, the summary array will contain the number 1111 in those locations for which no value was determined.

The stability margin search is limited to parameter values of the same sign as the nominal value. Thus zero is the lowest absolute magnitude that will be considered for the lower stability boundary of a parameter with a positive nominal value.

#### 4.9 Transfer Function Commands

##### TRANSFER FUNCTION

This program command initiates the calculation of a transfer function (frequency response function), between any two specified terms in the model. Associated with this command are the program names:

TF INPUT = transfer function input variable.

TF OUTPUT = transfer function output variable

which specify the input and output points in the system model. These quantities must be set to the desired names before requesting the transfer function calculation. They may be set to any valid state, rate, variable, or parameter name. However, the denominator order must be at least one greater than the numerator order.

BODE (Default Output)

NYQUIST

NICHOLS

These program commands specify the format to be used for the transfer function plots. The format must be specified before requesting the TRANSFER FUNCTION. If not specified, the default will be a Bode plot format. Transfer function plots are only available as off-line plots. Thus PLOT ON must also be specified before requesting a TRANSFER FUNCTION analysis.

TF AUTO SCALES (Default Condition)

TF MANUAL SCALES

These program commands allow the frequency range of the transfer function plots to be either automatically determined by the range of eigenvalues or to be specified by the program values:

FREQ MIN = minimum frequency, r.p.s.

FREQ MAX = maximum frequency, r.p.s.

The default condition is for auto scales.

Example 4.12:

PLOT ON

TF INPUT = FINLA, TF OUTPUT = FO LA

NICHOLS, TRANSFER FUNCTION

This example will generate a transfer function from FINLA to FO LA, with automatic (default) scales for the plotted results in a Nichol's chart format.

#### 4.10 Root Locus Commands

##### ROOT LOCUS

This program command initiates the calculation of a root locus. Associated with this command are the program name and values:

RL PARAMETER = root locus parameter name  
RL START = initial value of root locus parameter  
RL STOP = final value of root locus parameter  
RL POINTS = number of rootings to be made going from RL  
START to RL STOP.

RL PARAMETER specifies the parameter which will be scanned from the value RL START to RL STOP for RL POINTS. The default values of RL PARAMETER, RL START, RL STOP, and RL POINTS are; blank, 0, 1, and 6 respectively.

The root locus parameter, like the steady state parameter, can be either a valid parameter name or a state variable name followed by the phrase IC. This latter usage is meaningful only if the specified state variable has been frozen using the INT CONTROL command. In this way, a root locus can be performed as a function of the operating point value of a frozen state variable. ROOT LOCUS plots are available as off-line or printer plots.

RL AUTO SCALES (Default Condition)  
RL MANUAL SCALES

These program commands allow the scales of the root locus off-line plots to be either automatically determined by the range of eigenvalues or to be specified by the program values:

REAL MIN = minimum real axis range, r.p.s.  
REAL MAX = maximum axis range, r.p.s.

IMAG MIN = minimum imaginary axis range, r.p.s.

IMAG MAX = maximum imaginary axis range, r.p.s.

The default condition is for auto scales.

Example 4.13:

RL PARAMETER = P1 TF, RF START = 0, RL STOP = 5

RL POINTS = 6, ROOT LOCUS

In this example the root locus parameter P1 TF is scanned from 0 to 5 at six equally spaced values.

Example 4.14: (State Variable example)

RL MANUAL SCALES, REAL MAX=5, IMAG MAX=5, INT CONTROL, U SG =0

RL PARAMETER = U SG, IC, RL START = 35, RL STOP = 45

ROOT LOCUS

In this example manual scales are specified for the root locus plots. The state variable U SG is then frozen and a root locus is performed on the U SG operating point.

#### 4.11 Eigenvalue Sensitivity Commands

##### EIGEN SENSITIVITY

This program command causes a linear approximation of the given nonlinear model to be generated and then evaluates the sensitivity of the system eigenvalues to a parameter specified by the program name EIGEN PARAMETER.

Example 4.15:

EIGEN PARAMETER = GPITF, EIGEN SENSITIVITY

A description of the eigenvalue sensitivity measure is given in Section 4.4.7 of Reference 2.

#### 4.12 Function Scan Commands

SCAN1

SCAN2

These program commands initiate the calculation of general algebraic functions of one (SCAN1) or two (SCAN2) independent variables. Associated with these commands are the following program names and values:

DEPEN = dependent variable  
INDEP1 = 1st independent variable  
INDEP2 = 2nd independent variable  
START1 = starting point of 1st independent variable  
STOP1 = stopping point of 1st independent variable  
START2 = starting point of 2nd independent variable  
DELTA2 = increment of 2nd independent variable  
CURVES2 = number of curves

which specify the dependent and independent variables and scan ranges of these quantities. These quantities must be set to their desired values, before requesting the general algebraic function evaluation. If a single function is requested, i.e. SCAN1, only items DEPEN, INDEP1, START1, and STOP1 need be specified.

The output from the function scan commands is only available as off-line plots. Thus PLOT ON must be specified prior to SCAN1.

Example 4.16:

```
PLOT ON  
DEPEN = W2 TU, INDEP1 = EN SH, INDEP2 = P1 DE2, START1 = 30  
STOPI = 100, START2 = 10, DELTA2 = 2.0, CURVES2 = 6  
SCAN2
```

In this example, the quantity W2 TU will be calculated as a function of quantities EN SH and P1 DE2.

Six curves will be generated with EN SH ranging from 30 to 100 and P1 DE2 being stepped from 10 to 20 in increments of 2.

#### 4.13 Define Commands

```
DEFINE STATES  
DEFINE RATES  
DEFINE PARAMETERS  
DEFINE VARIABLES
```

These program commands may be used to define the alphanumeric names that will be used to refer to states, rates, parameters, and variables. All system models formed by the EASY Model Generating program have model related names generated for all states, variables, and parameters in the model. State variable derivatives, (Rates), are generated as R1, R2, . . . for all models. R1, R2 . . . refer to the rates of the first, second, . . . states respectively. If it is desired to replace these machine generated names with other names, the DEFINE command may be used to substitute any eight character names of the analyst's choosing. These names are stored in the labeled commons /CNAMEX/, /CNAMER/, /CNAMEP/, /CNAMEV/ and are associated with the corresponding numeric quantities located in the labeled commons /CX/, /CXDOT/, /CP/, and /CV/.

Each of these commands is followed by phrases of the form of a numeric followed by an alphanumeric name with one to eight characters the first of which must be alphabetic.

Example 4.17:

```
DEFINE STATES
1 = PRESSURE, 2 = STROKE, 5 = VELOCITY, 7 = ANGLE,
DEFINE PARAMETERS
5 = MASS, 35 = DCT AREA
DEFINE VARIABLES 1 = T OUTLET, 2 = LIQ H2O
```

#### 4.14 Optimal Controller Design Commands

In order to design an optimal controller using the EASY program, it is necessary to specify the inputs and outputs of the optimal controller as part of the system model description. This is accomplished as described in Section 2.1.2. Once a model has been generated that contains an optimal controller and the specified input-output connections to the other model components, many different controllers can be designed. These variations are made by varying the operating point or the optimal controller design criteria. The following paragraphs describe how the optimal controller operating point and criteria are specified.

Once an optimal controller has been designed, it may be desired to save that design for further analysis on subsequent analysis runs. Program commands are provided to save the data arrays which specify a particular optimal controller and to read such data on subsequent analysis runs.

#### O.C. DATA

The O.C. DATA command specifies that the following command phases contain data for one or more of the ten different data arrays related to optimal controllers. The name of each of these arrays and a brief description of its use is given below. For a more complete description of each array and its use, see Section 4.5 of reference (2).

## Optimal Controller - Operating Point Specification

- YOP Optimal controller input operating point (set-point) array. YOP is an  $n_s$  dimensional array, where  $n_s$  is the number of inputs to the optimal controller. Default values of zero are provided for this array.
- UOP Optimal controller output operating point (set-point) array. UOP is an  $n_u$  dimensional array, where  $n_u$  is the number of outputs from the optimal controller. Default values of zero are provided for this array.

## Optimal Controller Criteria Specification

- Q Optimal controller criteria weights array. Q is an  $n_c$  dimensional array, where  $n_c$  is the number of optimal controller criteria variables. Q contains the diagonal elements of the positive semi-definite weighting matrix which gives the importance of the various criteria variables relative to each other and the controller outputs. If the criteria variables are not specified, they are assumed to be the optimal controller inputs. Default values of 1 are provided for this array.
- RU Optimal controller control weights array. RU is an  $n_u$  dimensional array, where  $n_u$  is the number of optimal controller outputs. RU contains the diagonal elements of the positive definite matrix which gives the importance of the various controller outputs relative to each other and the criteria variables. Default values of 1 are provided for this array.
- CD System model disturbance covariance array. CD is an  $n_x$  dimensional array, where  $n_x$  is the order of the system model. CD contains the diagonal elements of the model disturbance covariance matrix which gives the uncertainty of various model states relative to each other and the sensed quantities. Larger values in CD imply greater uncertainty (less confidence) in the system model accuracy. Default values based on the ERROR vector and the model stability matrix are provided for this array.

CS Optimal controller inputs disturbance covariance array. CS is an  $n_s$  dimensional array, where  $n_s$  is the number of inputs to the optimal controller. CS contains the diagonal elements of the sensed quantity disturbance covariance matrix which gives the uncertainty of various sensed quantities relative to each other and the model states. Larger values in CS imply greater uncertainty (less confidence) in the sensed quantity accuracy. Default values based on the ERROR vector and the model sensor matrix are provided for this array.

Optimal Controller Specification - (Used only for input of previously designed optimal controller)

G Optimal controller gain array. G is an  $n_u$  by  $n_{rc}$  dimensional array, where  $n_u$  is the number of outputs from, and  $n_{rc}$  is the order of the optimal controller. Default values of zero are provided for this array until a DESIGN O.C. command is executed.

S Optimal controller sensor array. S is an  $n_{rc}$  by  $n_s$  dimensional array, where  $n_{rc}$  is the order of the optimal controller and  $n_s$  is the number of inputs to the optimal controller. Default values of zero are provided for this array until a DESIGN O.C. command is executed.

AK Optimal controller stability matrix array. AK is an  $n_{rc}$  by  $n_{rc}$  dimensional array where  $n_{rc}$  is the order of the optimal controller. Default values of zero are provided for this array until a DESIGN O.C. command is executed.

FK Optimal controller d.c. gain matrix array. FK is an  $n_u$  by  $n_s$  dimensional array where  $n_u$  is the number of outputs from, and  $n_s$  is the number of inputs to the optimal controller. Default values of zero are provided for this array until a DESIGN O.C. command is executed.

Optimal controller array data may be entered in a free field format with each data item separated by one of the standard delimiters (see Table 1). Data may be entered along either a row, column or diagonal line of the array. The row and column location is given for only the first element specified. The following input values are loaded in the subsequent row, column or diagonal elements of the array. The letters, C, R, and D signal the start of a new Column, Row, or Diagonal input. They must be followed by the row and column number at which data loading is to start. A column number of 1 must be given for the one dimensional arrays: YOP, UOP, Q, RU, CD and CS. The letter Z causes all elements of the array to be set to zero. This command may be used to advantage when loading a sparse array.

If the number of data values exceeds either the row or column dimension of the array, the excess values are ignored by the program.

The following examples demonstrate the loading of data into the optimal controller arrays.

Example 4.18:

PROGRAM COMMANDS

O.C. DATA

YOP = C (1,1) 553.2, 546, -2.56, 7

RESULTS - Assuming YOP is a 4x1 array.

$$YOP = \begin{pmatrix} 553.2 \\ 546. \\ -2.56 \\ 7.00 \end{pmatrix}$$

## DESIGN O.C.

The DESIGN O.C. command initiates the optimal controller design process. Before issuing this command, the following items should be accomplished:

1. Specify the optimal controller operating point by loading the arrays YOP and UOP.
2. Place the system model at the desired operating point.
3. Specify those optimal controller criteria arrays Q, RU, CD, and CS which differ from the default values.

The DESIGN O.C. command causes a linear model of the system to be generated and an optimal controller to be designed. The design results are printed and loaded into the optimal controller arrays G, S, AK, and FK. Manual modifications to the optimal controller can be made via the O.C. DATA command.

## SAVE O.C.

The SAVE O.C. command causes the optimal controller arrays G, S, AK, and FK to be punched out onto data cards in a format compatible with the O.C. DATA command. By including these cards in the input data for subsequent analysis runs, it is possible to perform further analyses on a previously calculated optimal controller. Such optimal controller data could be used in conjunction with the O.C. ANALYSIS command to the Model Generation program. As described in Section 2.1.2, the O.C. ANALYSIS command allows analyses to be performed on a previously designed optimal controller with less computer central memory than is required to perform the optimal controller design.

### 4.15 Warning Messages

One or more of the following warning messages will occur if the program encounters difficulty in interpreting analysis instructions or performing an analysis. These messages will be preceded by:

\*\*\*WARNING\*\*\* or \*\*\*NOTICE\*\*\*

The symbols xxx, zzz, or nnn are used to indicate phrases from the analysis description that are included as part of the warning message. The following messages are listed in alphabetical order:

1. A VALID PARAMETER NAME MUST PRECEDE THE NUMERIC VALUE nnn

This message indicates that a valid parameter name was not identified preceding the numeric value nnn. Check for missing delimiters or misspelled parameter name.

2. ALGEBRAIC LOOP WITH GAIN OF nnn EXISTS BETWEEN INPUT AND OUTPUT. THIS TRANSFER FUNCTION CANNOT BE CALCULATED.

See Section 4.4.5 of Reference 2 for a description of this limitation to the transfer function analysis method.

3. xxx CAN'T BE SET EQUAL TO zzz. VALUE MUST BE NUMERIC

Check for missing numeric value or delimiters.

4. CAN'T IDENTIFY xxx AS A VALID EIGENVALUE SENSITIVITY PARAMETER.

Check spelling of eigenvalue sensitivity parameter or for missing delimiters.

5. CAN'T IDENTIFY xxx AS A VALID PRINT VARIABLE

Check spelling of xxx or for missing delimiters.

6. CAN'T IDENTIFY xxx AS A VALID ROOT LOCUS

Check spelling of xxx or for missing delimiters.

7. CAN'T IDENTIFY xxx AS A VALID SCAN PARAMETER

Check spelling of xxx or for missing delimiters.

8. CAN'T IDENTIFY xxx AS A VALID STABILITY MARGIN PARAMETER

Check spelling of xxx or for missing delimiters.

9. CAN'T IDENTIFY xxx AS A VALID STEADY STATE PARAMETER

Check spelling of xxx or for missing delimiters.

10. CAN'T IDENTIFY xxx AS A VALID TRANSFER FUNCTION INPUT (OUTPUT) PARAMETER

Check spelling of xxx or for missing delimiters.

11. CAN'T IDENTIFY xxx VALUE WILL BE IGNORED

This will result in not setting the quantity intended by xxx to its new value. Check for spelling of xxx or for missing delimiters.

12. CAN'T INTERPRET xxx

The phrase xxx cannot be recognized as a valid program command, program name, or program value. Check spelling of xxx or for missing delimiters.

13. CAN'T LOAD CRITERIA ARRAYS WHEN IN ANALYSIS ONLY MODE

The O.C. ANALYSIS command was issued to the Model Generation program when it created the system model. Therefore, an optimal control design, which used this criteria arrays, cannot be performed.

14. nnn EXCEEDS THE ALLOWABLE INDEX RANGE FOR xxx THIS QUANTITY WILL NOT BE DEFINED

The number nnn was outside the allowable range of states, rates, variables, or parameters. Therefore, the name xxx cannot be assigned as a name for the nnth state, rate, variable or parameter.

15. xxx EXCEEDS 10. SOLUTION MAY BE INVALID.

For a valid steady state, all rates should be driven to near zero. If the absolute value of one or more rates exceeds 10 after SS ITERATIONS, this message will be generated. An interlock will also be set to prevent a simulation run from being made using the invalid results of this steady state analysis. See Section 4.4.2 Reference (2) for alternative methods of reaching steady state.

16. FAILED TO CONVERGE TO ZERO PHASE

The search procedure described in Section 4.4.4 Reference (2) failed to converge to zero phase. The stability margin for the indicated parameter cannot be determined by this method.

17. NOMINAL SYSTEM UNSTABLE

The nominal system is unstable. The stability margins of the specified parameters will be calculated but these bounds will be "noncritical" bounds since the nominal system is unstable. See Section 4.4.4 Reference (2) for a discussion of critical and noncritical stability boundaries.

18. NON-ALPHA NAME ON THIS CARD ---> xxx. WILL IGNORE THIS CARD.

The table inputs routine expected an alphanumeric table name but encountered a numeric value on the data card printed. Check the sequence and number of tabular data cards to assure that they match those required by the model's tables and table input formats. See Section 4.1.2 Reference (2) for correct formats.

19. NON-NUMERIC DATA ON THIS CARD ---> xxx. WILL READ NEXT TABLE

The table input routine expected a numeric value but encountered an alphanumeric name on the data card printed. Check that the sequence and number of tabular data cards matches the model's tables and table input formats. See Section 4.1.2 Reference (2) for correct formats.

20. nnn PRIMARY AND xxx SECONDARY INDEPENDENT VARIABLE POINTS EXCEEDS THE zzz WORD STORAGE LIMIT FOR THE FOLLOWING TABLE. SOME DATA WILL BE LOST.

See Section 3.7.1 Reference (2) for a discussion of the maximum number of data points allowed for each table.

21. SIMULATION WILL NOT BE RUN DUE TO FAILURE TO REACH VALID STEADY STATE.

A failure of the steady state analysis followed by a request to transfer X into XIC causes an interlock to be set which will prevent a simulation run from beginning from an erroneous initial condition.

22. WORK SPACE WAS NOT PROVIDED IN MODEL FOR OPTIMAL CONTROLLER DESIGN.

Either no optimal controller was specified to the Model Generation program or the O.C. ANALYSIS mode was indicated. In either case, only analyses and not O.C. Design can be performed with this model.

23. \*\*\* WARNING \*\*\* MATRIX IS SINGULAR \*\*\*  
INITIAL SYSTEM IS NOT DIAGONALIZABLE

This message is generated in the system reduction program and is the result of multiple eigenvalues with a single eigenvector. This means that the system is not able to be diagonalized and that a Jordan type reduction is required. Processing is stopped and reduction is not completed. This message can arise either in the reduction of the initial model equations or in the reduction of the controller.

24. \*\*\* WARNING \*\*\*QR FAILED TO CONVERGE IN XX STEPS  
\*\*\* WARNING \*\*\*INITIAL SYSTEM IS NOT DIAGONALIZABLE

This message generated in the system reduction program is the result of the extremely rare event of the eigenvalue calculation failure.

25. \*\* DUE TO xxx UNSTABLE EIGENVALUES, SYSTEM REDUCTION TO xxx IS IMPOSSIBLE

This message generated in the system reduction program is the result of the number of unstable eigenvalues in the system to be reduced being greater than the requested order for the reduced system. This message can arise either in the reduction of the initial system or in the reduction of the controller.

26. \*\* CONTROL WEIGHTING NOT POSITIVE DEFINITE

This message generated in the calculation of the optimal feedback matrix is the result of loss of significance in the calculation of the control weighting matrix. Since the default check is made, this is a rare event.

27. \*\*... QR ALGORITHM FAILED TO CONVERGE  
\*\*... SYSTEM MAY BE UNSTABILIZABLE

This message generated in the calculation of the optimal feedback matrix is the result of the QR algorithm failure and is a rare event.

28. \*\*... SPECTRAL FACTORIZATION OF EIGENVALUES NOT OBTAINED  
\*\*... SYSTEM MAY BE UNSTABILIZABLE

This message generated in the calculation of the optimal feedback matrix is the result of an eigenvalue with a zero real part preventing spectral factorization. It is the result normally of an uncontrollable mode with an eigenvalue with a zero or very small real part.

29. \*\*... MATRIX IS SINGULAR  
\*\*... SYSTEM PLUS ADJOINT EQUATIONS NOT DIAGONALIZABLE OR  
SYSTEM IS UNSTABILIZABLE

This message generated in the calculation of the optimal feedback matrix is the result of the set of pseudo eigenvectors calculated for the partitioned eigenvalues being singular in the top block. This condition normally means that an unstable, uncontrollable mode existed in the original system. Another, but rare, possibility is that due to multiple eigenvalues, the system plus adjoint equations was not diagonalizable.

30. \*\*... QR FAILED TO CONVERGE  
\*\*... SYSTEM MAY BE UNOBSERVABLE

This message is generated during the calculation of the Kalman filter and is the result of the QR algorithm failure and is a rare event.

31. \*\*...SPECTRAL FACTORIZATION OF EIGENVALUES NOT OBTAINED  
\*\*...SYSTEM MAY BE UNOBSERVABLE

This message is generated during the calculation of the Kalman filter and is the result of an eigenvalue with zero real part preventing spectral factorization. It is normally the result of an unobservable mode with an eigenvalue with zero or very small real part.

32. \*\*.. MARTIX IS SINGULAR  
\*\*.. SYSTEM MAY BE UNOBSERVABLE

This message is generated during the calculation of the Kalman filter and is normally the result of an unstable unobservable mode. Like the case in the gain matrix calculation (4.4.30) Reference (2) it can rarely be the result of the system and adjoint equations being undiagonalizable.

33. \*\*... QR ALGORITHM FAILED TO CONVERGE

This message occurs when during a simple eigenvalue calculation, convergence was not obtained. This is a rare event.

34. \*\*... SYSTEM HAS SINGULAR ALGEBRAIC LOOP

This message generated during the adjustment of the controller is the result of cancellation in algebraic feedforward and feedback loops. It can normally be corrected by the use of an alternative adjustment method.

## SECTION V

### AIRCRAFT ANALYSIS EXAMPLE

In this section the use of the aircraft components and the analysis commands is demonstrated. Section 5.1 shows how to construct a basic airplane model for a fixed operating point, i.e., for constant aerodynamic derivatives as well as how to use tabular input data for basic aerodynamic coefficients.

Section 5.2 shows details of how to use the Optimal Control features in order to find trim conditions.

#### 5.1 Constant Coefficient Aero Models

The basic modules required to model airplane dynamics are the 4 components VA, OL, DL, DS. VA takes the airplane states and computes aero variables such as angle-of-attack, sideslip, and dynamic pressure. OL and DL are the longitudinal and lateral-directional aero force and moment computations. DS contains the rigid body dynamics for integrating the aircraft states, and is driven by the aerodynamic forces and moments generated in OL and DL. All other components making up an airplane model are attached to one or more of these components. For example, nonlinear and external forces and torques due to trunk, engine thrust, etc., are inputs to OL and DL. Control systems, on the other hand, require inputs from state variables in DS or aero-variables in VA and determine the control surface settings which are passed to OL or DL. This model structure is demonstrated with a six degree of freedom model of the Jindivik RPV drone.

Proper data preparation with the constant coefficient aero model requires an understanding of the assumptions and mechanics underlying the force and moment modules OL and DL. Inputs to these components include external forces and torques and aero-stability derivatives for all six degrees of freedom. The external force and moment inputs must be the sum of any effect such as engine, trunk (landing gear), or other effects that are not modeled in OL and DL.

These forces and moments are combined with the linear aero forces and moments in body axes and output as total force and moment vectors about the aircraft c.g. The modules also solve for the linear acceleration  $\dot{u}$ ,  $\dot{v}$  and  $\dot{w}$  in order to compute the implicit aero terms due to  $\dot{\alpha}$  and  $\dot{\beta}$ . The body axis linear accelerations  $\dot{u}$ ,  $\dot{v}$ ,  $\dot{w}$  and the torques  $L=TX$ ,  $M=TY$ , and  $N=TZ$  are then passed to the equations-of-motion module DS. The aero derivatives can be specified in either stability axes or in body axes. If stability axes are used, then ALSVA specifies the trim angle-of-attack for the data. Due to small modeling or data inconsistencies, the actual trim alpha obtained with the 6D model may be different than ALSVA. However, a large discrepancy between the specified and actual trim is cause for suspecting a data error or model inconsistency. If body axes are used, then ALSVA denotes the reference alpha for the alpha coefficients  $X_A$ ,  $Z_A$ ,  $MAL$ , and can be zero or nonzero, depending on the data source. The neutral point minus c.g. value,  $XP10L$ , is an important parameter for the pitching moment equation. However, the effect of this term is sometimes included in the  $C_{M\alpha}$  and  $C_{M0}$  coefficients (see Etkin, pp. 208-209, Reference [4]). If this is the case, then  $XP10L$  should be set to zero. Finally, if dimensional data is used, it is important to note that the units used in OL and DL are all ft-lb-sec-deg units. If the dimensional data is given in normalized units as for example on pp. 294, 295 of McFuer Ashkenas, and Graham, Reference [5], then the following factors are required to convert the data:

	<u>STABILITY DERIVATIVE</u>		<u>FACTOR</u>
OL	XO, XA, XU, ZO, ZA, ZAD, ZU	-	MA
	XDE, ZDE, ZQ	-	MA*RPD
	MO, MAL, MAD, MU	-	Iyy
	MQ, MDE	-	Iyy*RPD
DL	YB, YBD <sup>1</sup>	-	MA/VT
	YP, YR, YDR, YDA	-	MA*RPD
	LB, LBD <sup>1</sup>	-	Ixx/VT
	LP, LR, LDR, LDA	-	Ixx*RPD
	NB, NBD <sup>1</sup>	-	Izz/VT
	NP, NR, NDR, NDA	-	Izz*RPD
<sup>1</sup> Assumes $\beta$ , $\dot{\beta}$ derivatives given			

with  $RPD = \pi/180$   
 $MA =$  rigid body aircraft mass, slugs  
 $I_{xx}, I_{yy}, I_{zz} =$  body axis moments of inertia, slug-ft<sup>2</sup>  
 $VT =$  steady state true airspeed, ft/sec.

### 5.1.1 Six Degree of Freedom Aerodynamic Model

A basic six degree of freedom constant coefficient airplane model is now analyzed. In addition to the basic airplane modules VA, DL, OL, DS, and ES we need to incorporate the component AC where the basic aerodynamic coefficients (XO, ZO, MO, YB, LB, NB) are interpolated from tabular data (one dimensional tables) as functions of angle of attack ( $\alpha$ ) or of sideslip ( $\beta$ ); and an optimal control module O.C. to obtain straight and level trim. Figure 6 shows the model description for the basic Jindivik airplane. The basic airplane and optimal control module schematic diagram generated by the EASY program is shown in Figure 7. Inputs to the optimal controller component include the attitude angles, altitude, true airspeed and some of the velocity states. The

```

MANND CARD --- MODEL DESCRIPTION SIX DEGREE TEST CASE
MANND CARD --- LOCATION=07 VA INPUTS=DS
MANND CARD --- LOCATION=56 AC INPUTS=VA
MANND CARD --- LOCATION=71 DC
MANND CARD --- O.C. INPUTS=ALTUS,VT,VA,ROL,DS,PITDS,VARD6
MANND CARD --- P DS,O DS,R DS,V DS,W DS
MANND CARD --- O.C. OUTPUTS=ELEOL,THRES,AI,DA
MANND CARD --- LOCATION= 1 ES
MANND CARD --- LOCATION= 3 OL INPUTS=VA,ES,AC
MANND CARD --- LOCATION=37 OL INPUTS=OL,VA,AC
MANND CARD --- LOCATION=10 DS INPUTS=OL,DL
MANND CARD --- END OF MODEL
MANND CARD --- PRINT

```

Figure 6 J1ndivik 600F Airplane Model

ENGINE	SIX DEGREE TEST CASE	LONGITUDINAL FORCES & MOMENTS	LATERAL FORCES AND MOMENTS	AERO. VARIABLES AND AXIS TRANSFORMATION	SIX DOF RIGID BODY DYNAMICS
01 UC	01 UC	01 UC	01 UC	01 UC	01 UC
02 UC	02 UC	02 UC	02 UC	02 UC	02 UC
03 UC	03 UC	03 UC	03 UC	03 UC	03 UC
04 UC	04 UC	04 UC	04 UC	04 UC	04 UC
05 UC	05 UC	05 UC	05 UC	05 UC	05 UC
06 UC	06 UC	06 UC	06 UC	06 UC	06 UC
07 UC	07 UC	07 UC	07 UC	07 UC	07 UC
08 UC	08 UC	08 UC	08 UC	08 UC	08 UC
09 UC	09 UC	09 UC	09 UC	09 UC	09 UC
10 UC	10 UC	10 UC	10 UC	10 UC	10 UC
11 UC	11 UC	11 UC	11 UC	11 UC	11 UC
12 UC	12 UC	12 UC	12 UC	12 UC	12 UC
13 UC	13 UC	13 UC	13 UC	13 UC	13 UC
14 UC	14 UC	14 UC	14 UC	14 UC	14 UC
15 UC	15 UC	15 UC	15 UC	15 UC	15 UC
16 UC	16 UC	16 UC	16 UC	16 UC	16 UC
17 UC	17 UC	17 UC	17 UC	17 UC	17 UC
18 UC	18 UC	18 UC	18 UC	18 UC	18 UC
19 UC	19 UC	19 UC	19 UC	19 UC	19 UC
20 UC	20 UC	20 UC	20 UC	20 UC	20 UC
21 UC	21 UC	21 UC	21 UC	21 UC	21 UC
22 UC	22 UC	22 UC	22 UC	22 UC	22 UC
23 UC	23 UC	23 UC	23 UC	23 UC	23 UC
24 UC	24 UC	24 UC	24 UC	24 UC	24 UC
25 UC	25 UC	25 UC	25 UC	25 UC	25 UC
26 UC	26 UC	26 UC	26 UC	26 UC	26 UC
27 UC	27 UC	27 UC	27 UC	27 UC	27 UC
28 UC	28 UC	28 UC	28 UC	28 UC	28 UC
29 UC	29 UC	29 UC	29 UC	29 UC	29 UC
30 UC	30 UC	30 UC	30 UC	30 UC	30 UC
31 UC	31 UC	31 UC	31 UC	31 UC	31 UC
32 UC	32 UC	32 UC	32 UC	32 UC	32 UC
33 UC	33 UC	33 UC	33 UC	33 UC	33 UC
34 UC	34 UC	34 UC	34 UC	34 UC	34 UC
35 UC	35 UC	35 UC	35 UC	35 UC	35 UC
36 UC	36 UC	36 UC	36 UC	36 UC	36 UC
37 UC	37 UC	37 UC	37 UC	37 UC	37 UC
38 UC	38 UC	38 UC	38 UC	38 UC	38 UC
39 UC	39 UC	39 UC	39 UC	39 UC	39 UC
40 UC	40 UC	40 UC	40 UC	40 UC	40 UC
41 UC	41 UC	41 UC	41 UC	41 UC	41 UC
42 UC	42 UC	42 UC	42 UC	42 UC	42 UC
43 UC	43 UC	43 UC	43 UC	43 UC	43 UC
44 UC	44 UC	44 UC	44 UC	44 UC	44 UC
45 UC	45 UC	45 UC	45 UC	45 UC	45 UC
46 UC	46 UC	46 UC	46 UC	46 UC	46 UC
47 UC	47 UC	47 UC	47 UC	47 UC	47 UC
48 UC	48 UC	48 UC	48 UC	48 UC	48 UC
49 UC	49 UC	49 UC	49 UC	49 UC	49 UC
50 UC	50 UC	50 UC	50 UC	50 UC	50 UC
51 UC	51 UC	51 UC	51 UC	51 UC	51 UC
52 UC	52 UC	52 UC	52 UC	52 UC	52 UC
53 UC	53 UC	53 UC	53 UC	53 UC	53 UC
54 UC	54 UC	54 UC	54 UC	54 UC	54 UC
55 UC	55 UC	55 UC	55 UC	55 UC	55 UC
56 UC	56 UC	56 UC	56 UC	56 UC	56 UC
57 UC	57 UC	57 UC	57 UC	57 UC	57 UC
58 UC	58 UC	58 UC	58 UC	58 UC	58 UC
59 UC	59 UC	59 UC	59 UC	59 UC	59 UC
60 UC	60 UC	60 UC	60 UC	60 UC	60 UC
61 UC	61 UC	61 UC	61 UC	61 UC	61 UC
62 UC	62 UC	62 UC	62 UC	62 UC	62 UC
63 UC	63 UC	63 UC	63 UC	63 UC	63 UC
64 UC	64 UC	64 UC	64 UC	64 UC	64 UC
65 UC	65 UC	65 UC	65 UC	65 UC	65 UC
66 UC	66 UC	66 UC	66 UC	66 UC	66 UC
67 UC	67 UC	67 UC	67 UC	67 UC	67 UC
68 UC	68 UC	68 UC	68 UC	68 UC	68 UC
69 UC	69 UC	69 UC	69 UC	69 UC	69 UC
70 UC	70 UC	70 UC	70 UC	70 UC	70 UC
71 UC	71 UC	71 UC	71 UC	71 UC	71 UC
72 UC	72 UC	72 UC	72 UC	72 UC	72 UC
73 UC	73 UC	73 UC	73 UC	73 UC	73 UC
74 UC	74 UC	74 UC	74 UC	74 UC	74 UC
75 UC	75 UC	75 UC	75 UC	75 UC	75 UC
76 UC	76 UC	76 UC	76 UC	76 UC	76 UC
77 UC	77 UC	77 UC	77 UC	77 UC	77 UC
78 UC	78 UC	78 UC	78 UC	78 UC	78 UC
79 UC	79 UC	79 UC	79 UC	79 UC	79 UC
80 UC	80 UC	80 UC	80 UC	80 UC	80 UC

Figure 7 Jindivik Airplane and Trim Components

desired trim conditions are specified as inputs to this module and error signals are generated which drive the optimal controller (O.C.) outputs. Figure 7 shows the O.C. inputs and the O.C. output to regulate engine thrust, as well as the aileron and elevator O.C. command outputs (Jindivik control system does not have rudder). The names of output quantities providing connections between various components are given.

The data required to do an analysis with this model is specified by the input lists for the components in Section 3, except that no data is required (or accepted) for inputs connected to (supplied by) another component. The model generation program also lists the data requirements and Figure 8 shows this list for the 6DOF Model.

#### Subroutines EQMO and DATAIN

The source code for the EQMO and DATAIN subroutines are the primary output of the EASY Model Generation program. These subroutines contain the system math model and the means to load tabular data into that model.

#### Subroutine EQMO

For a system model comprised entirely of standard components, the model equations are obtained in EQMO by a series of calls to standard component subroutines. Each call is labeled with comments that identify the component name. Figure 9 contains a listing of the EQMO subroutine for the 6DOF Example.

COMMON areas are provided for the state variables, variables, parameters, and tables in the model. These COMMON's allow access to these quantities by the EASY Analysis program. Three additional COMMON areas: CXDOT, CINT, and CTIME are used to store the state variable time derivatives, the integrator ON-OFF controls and the TIME variable. The integrator ON-OFF control can be used to freeze any selected state or states at a constant value.

The entry points VARSET and RATSET are used by the analysis program to enter the system model immediately following the point of calculation of any variable or state variable derivative, (rate). Such entries allow the analysis program to drive these quantities for certain analyses.









If the FORTRAN STATEMENTS command is used during the system model description, the lines of Fortran source code would appear in the EQMO subroutine between the component calls that preceded and followed the FORTRAN STATEMENTS command.

#### Subroutine DATAIN

The DATAIN subroutine sets the number of states, variables, and parameters into COMMON's that are accessed by the analysis program. The subroutine TABIN is then called to interpret tabular input data.

The analysis data used to demonstrate this model is shown in Figure 10. Following the command PARAMETER VALUES are the input data values for the aircraft components DL, VA, OL, ES, and DS. The aero coefficient tables are then input, and the non-zero INITIAL CONDITIONS for states complete the model definition. See Sections 4.1, 4.2, and 4.3 for a description of the input format corresponding to these commands. The aerodynamic tabular data was obtained from Reference (6) for 4<sup>0</sup> flaps while the supplementary data for stability derivatives was taken from Reference (7). All parametric and tabular input data are played back by the ANALYSIS program before executing the first analysis command, see Figure 11.

Default values of .99999 are initially assigned by the EASY Analysis program to all model parameters. However, certain parameters in VA, DL, OL, ES and DS have default values of 0 which are provided if the standard default value of .99999 is detected. Initial conditions for the state variables also have zero default values. Figure 12 shows the printout for the subject model. The commands beginning with O.C. DATA and ending with STEADY STATE, design the optimal controller, do a linear analysis and design and trim calculations). Figures 13 and 14 respectively show the printout of O.C. DESIGN and LINEAR ANALYSIS results. Figure 15 shows the printout of the STEADY STATE analysis for this case. The significant non-zero trim conditions are circled. The results give a steady state trim which approximates the desired flight conditions. If a more accurate solution is desired we can redesign the optimal controller at the new operating point and repeat the trim procedure, or put a heavier weight on the conditions requiring greater accuracy and rerun the analysis.



```

1. FREE ANALYSIS
INITIAL CONDITION=V DS=60
IMPLATE
2. PLATE
3. A.VS.WB VA
4. U.VS.WB VA
5. Z.VS.WB VA
6. ZD.VS.WB VA
7. FILE STEADY SCAN, LATERAL MOTION
INITIAL CONDITION=V DS=10.43
8. PARAMETER ON VA.SS START=40.SS STOP=0
9. POINTS=5,STEADY STATE
10. POWER TEMPERATURE
11. PLATE
12. VA.VS.TIME
13. U.VS.TIME
14. Z.VS.TIME
15. ZD.VS.TIME
16. F.VS.TIME
17. FZ.VS.TIME
18. FZD.VS.TIME
19. STATES
20. PARAMETER V DS=1.P DS=1.HOLD=1.R DS=1
21. FILE FREE LATERAL MODEL (STABILITY AXIS DATA)
FREE ANALYSIS
INITIAL CONDITION=V DS=10.3.W DS=10.43
IMPLATE
2. PLATE
3. VA.VS.TIME
4. U.VS.TIME
5. Z.VS.TIME
6. ZD.VS.TIME
7. STATES
8. PARAMETER V DS=1.V DS=1.W DS=1.P DS=1
9. DS=1.H DS=1.PTDS=1.HOLD=1.ALTDS=1
10. FILE FREE LONGI-LATERAL MODEL (STABILITY AXIS DATA)
FREE ANALYSIS
INITIAL CONDITIONS
2. DS=10.3.W DS=60
IMPLATE
3. FILE VERTICAL FORCE TRANSFER FUNCTION
4. INPUT MODEL IF OUTPUT=ALTUS,TRANSFER FUNCTION
5. FILE LONGI-TUDINAL TEMPER TRANSFER FUNCTION
6. INPUT TEMPER IF OUTPUT=PTDS,TRANSFER FUNCTION
7. POINTS,TRANSFER FUNCTION
8. POINTS,TRANSFER FUNCTION

```

Figure 10 Analysis Program-Input Data And Commands (Concluded)

PARAMETER VALUES

```

PARAMD CARD -----
VP DL=-.0218,LP DL=-.370,MP DL=.00167,LR DL=.4486

PARAMC CARD -----
MR DL=-.1646,LOAD=-.14184,MDADL=.0192

PARAMU CARD -----
IDUVA=0,ISHEL=3,IBLES=1,IFNES=1

PARAMV CARD -----
ID1VA=3,VS VA=728,ALSVA=0.5 VA=78

PARAMW CARD -----
TCRES=1,GAZES=0,XO ES=-10.9,ZO ES=-.378,PXIES=0.

PARAMX CARD -----
1RXDS=1190,1VYDS=1811,1ZZDS=2840,1XZDS=-300

PARAMY CARD -----
C DL=4.8 DL=19,MAIOL=83.97,HPICL=0

PARAMZ CARD -----
MEXOL=.847,MO DL=-.746,ZIXOL=.2894

PARAMO CARD -----
TABLE,CLTAC,7

```

TABLE CLTAC

PRIMARY INDEPENDENT VARIABLE TABLE

-15.00 -10.00 -5.000 0. 5.000 10.00 15.00

DEPENDENT VARIABLE TABLE

-1.270 -.7580 -2430 .2720 .7870 1.300 1.820

TABLE CDYAC

PRIMARY INDEPENDENT VARIABLE TABLE

-1.000 -.8000 -.1000 -.8000E-01 0. .8000E-01 .1000 .8000

DEPENDENT VARIABLE TABLE

.7750E-01 .5650E 01 .3870E-01 .3870E-01 .3730E-01 .3880E-01 .3880E-01 .3780E-01 .3880E-01 .6880E-01  
.8750E-01 .8650E-01

Figure 11 Playback of Parametric and Tabular Inputs

TABLE CMTAC

PRIMARY INDEPENDENT VARIABLE TABLE	
-1.000	.8000
0.	.1000
.2000	.3000
.4000	.5000
.6000	.7000
.8000	.9000
1.000	

DEPENDENT VARIABLE TABLE	
.1340	.3400E-01
.2190E-01	.8190E-01
.3390E-01	.5390E-01
.4680E-01	.4000E-01
.5400E-01	.3400E-01
.5200E-01	.2200E-01
.4000E-02	-.3600E-01

TABLE CMTAC

PRIMARY INDEPENDENT VARIABLE TABLE	
-90.00	-75.00
-60.00	0.
60.00	75.00
90.00	

DEPENDENT VARIABLE TABLE	
-.7500	-.7500
-.7500	-.7500
-.7500	-.7500
-.7500	-.7500

TABLE CMTAC

PRIMARY INDEPENDENT VARIABLE TABLE	
-20.00	0.
20.00	

DEPENDENT VARIABLE TABLE	
.1750	.8000E-01
.3500E-01	

Figure 11 Playback Of Parametric And Tabular Inputs (Continued)

TABLE CLM4C

PRIMARY INDEPENDENT VARIABLE TABLE

-20.00 0. 20.00

DEPENDENT VARIABLE TABLE

.1880 -.7500E-01 -.3320

\*\*\* WARNING \*\*\* DATA FOR TABLE TYPES HAS NOT BEEN INPUT

\*\*\* WARNING \*\*\* DATA FOR TABLE TYPES HAS NOT BEEN INPUT

\*\*\* WARNING \*\*\* DATA FOR TABLE TYPES HAS NOT BEEN INPUT

\*\*\* WARNING \*\*\* DATA FOR TABLE TYPES HAS NOT BEEN INPUT

\*\*\* WARNING \*\*\* DATA FOR TABLE TYPES HAS NOT BEEN INPUT

\*\*\* WARNING \*\*\* DATA FOR TABLE TYPES HAS NOT BEEN INPUT

PARAM1 CARD ----- INITIAL CONDITIONS

PARAM1 CARD ----- U 05-778,ALTD5-30000,P1TDS=1,TH ES=377

PARAM2 CARD ----- O.C. DATA

PARAM2 CARD ----- YOP=30000,728-0,1,0,0,0,0,0,0

PARAM3 CARD ----- UOP=0,377,0

PARAM4 CARD ----- Q=1,100,100,1,100,1,1,1,1,1,1

PARAM5 CARD ----- RW= 01, .01, .01

PARAM6 CARD ----- PRINT CLMTRK=3

PARAM7 CARD ----- DESIGN O.C. ← NEXT ANALYSIS

Check to make sure that these tables are not used in analysis you are going to request or else provide data for them.

Figure 11 Playback Of Parametric And Tabular Inputs (Concluded)

STATE NAMES

1 RI OC	2 RI OC	3 RI OC	4 RI OC	5 RI OC	6 RI OC	7 RI OC	8 RI OC	9 RI OC	10 RI OC
11 RI UC	12 RI ES	13 U DS	14 V DS	15 W DS	16 W DS	17 Q DS	18 R DS	19 R DLS	20 P DLS
21 YHDS	22 AL DS								

DATE NAMES

1 R1	2 R2	3 R3	4 R4	5 R5	6 R6	7 R7	8 R8	9 R9	10 R10
11 R11	12 R12	13 R13	14 R14	15 R15	16 R16	17 R17	18 R18	19 R19	20 R20
21 R21	22 R22								

VARIABLE NAMES

1 UD VA	2 VO VA	3 WD VA	4 PO VA	5 CO VA	6 RO VA	7 ID VA	8 OR VA	9 MI VA	10 CAL VA
11 SA VA	12 AL VA	13 AL PA	14 VT VA	15 BE VA	16 MP VA	17 UP VA	18 EU VA	19 EV VA	20 EB VA
21 SI VA	22 CA VA	23 MA VA	24 MA VA	25 ZO AC	26 HU AC	27 HO AC	28 YB AC	29 LB AC	30 HO AC
31 UT OC	32 UT OC	33 UT ES	34 TX ES	35 TX ES	36 TX ES	37 TX ES	38 TX ES	39 TX ES	40 TX ES
41 WY ES	42 TX ES	43 TX ES	44 TX ES	45 TX ES	46 TX ES	47 TX ES	48 TX ES	49 TX ES	50 TX ES
51 TX DS	52 TX DS	53 TX DS	54 TX DS	55 TX DS	56 TX DS	57 TX DS	58 TX DS	59 TX DS	60 TX DS

PARAMETER VALUES

1 ID VA	2 VS VA	3 AL VA	4 VA	5 VA	6 VA	7 VA	8 VA	9 VA	10 VA
11 VA	12 VA	13 VA	14 VA	15 VA	16 VA	17 VA	18 VA	19 VA	20 VA
21 VA	22 VA	23 VA	24 VA	25 VA	26 VA	27 VA	28 VA	29 VA	30 VA
31 VA	32 VA	33 VA	34 VA	35 VA	36 VA	37 VA	38 VA	39 VA	40 VA
41 VA	42 VA	43 VA	44 VA	45 VA	46 VA	47 VA	48 VA	49 VA	50 VA
51 VA	52 VA	53 VA	54 VA	55 VA	56 VA	57 VA	58 VA	59 VA	60 VA
61 VA	62 VA	63 VA	64 VA	65 VA	66 VA	67 VA	68 VA	69 VA	70 VA
71 VA	72 VA	73 VA	74 VA	75 VA	76 VA	77 VA	78 VA	79 VA	80 VA
81 VA	82 VA	83 VA	84 VA	85 VA	86 VA	87 VA	88 VA	89 VA	90 VA
91 VA	92 VA	93 VA	94 VA	95 VA	96 VA	97 VA	98 VA	99 VA	100 VA

\*\*\* MISSING \*\*\*

UNINITIALIZED PARAMETERS

11 VA	12 VA	13 VA	14 VA	15 VA	16 VA	17 VA	18 VA	19 VA	20 VA
21 VA	22 VA	23 VA	24 VA	25 VA	26 VA	27 VA	28 VA	29 VA	30 VA
31 VA	32 VA	33 VA	34 VA	35 VA	36 VA	37 VA	38 VA	39 VA	40 VA
41 VA	42 VA	43 VA	44 VA	45 VA	46 VA	47 VA	48 VA	49 VA	50 VA
51 VA	52 VA	53 VA	54 VA	55 VA	56 VA	57 VA	58 VA	59 VA	60 VA
61 VA	62 VA	63 VA	64 VA	65 VA	66 VA	67 VA	68 VA	69 VA	70 VA
71 VA	72 VA	73 VA	74 VA	75 VA	76 VA	77 VA	78 VA	79 VA	80 VA
81 VA	82 VA	83 VA	84 VA	85 VA	86 VA	87 VA	88 VA	89 VA	90 VA
91 VA	92 VA	93 VA	94 VA	95 VA	96 VA	97 VA	98 VA	99 VA	100 VA

Figure 12 Default Values for Parameters

OPTIMAL CONTROLLER DESIGN

1 ALTDS = 30000.      2 VT VA = 726.00      3 ROLDS = 0.      4 PITDS = 1.0000      5 VARD8 = 0.  
 6 P DS = 0.      7 O DS = 0.      8 R DS = 0.      9 V DS = 0.      10 W DS = 0.

1 OI OC = 0.      2 OI OC = 377.00      3 OJ OC = 0.

1 ALTDS      2 VT VA      3 ROLDS      4 PITDS      5 VARD8  
 6 P DS      7 O DS      8 R DS      9 V DS      10 W DS

MODEL ORDER      11      ( 11 - MODEL ORDER USED FOR O.C. DESIGN)  
 O.C. ORDER      11  
 TOTAL SYSTEM ORDER      22

Note: The various O.C. - matrices that are part of the O.C. DESIGN output are not shown here.

SYSTEM EIGENVALUES USING CONTROLLER OF ORDER 11

- 413.78      0.
- 222.34      0.
- 148.55      0.
- 176.89      0.
- 124.42      0.
- 48.959      0.
- 6.6637      0.
- 3.3106      2.8922
- 3.3106      -2.8922
- 1.2151      -77278
- 1.2151      -77278
- 76106      -61475
- 76106      -61475
- 1.0002      0.
- 13.650      0.
- 12.788      0.
- 13.475      0.
- 44103E-01      0.
- 10.175      0.
- 10.113      0.
- 10.228      0.
- 10.072      0.

All negative real eigenvalues indicate a stable system design.

Figure 13 Optimal Controller Design

LINEAR ANALYSIS

STATE NAME	OPERATING POINT	PERTURBATION SIZE	INTEGRATOR CONTROL
1 X1 OC	0.	.100	1
2 X2 OC	0.	.100	1
3 X3 OC	0.	.100	1
4 X4 OC	0.	.100	1
5 X5 OC	0.	.100	1
6 X6 OC	0.	.100	1
7 X7 OC	0.	.100	1
8 X8 OC	0.	.100	1
9 X9 OC	0.	.100	1
10 X10OC	0.	.100	1
11 A11OC	0.	.100	1
12 IH ES	377.00	.100	1
13 U DS	728.00	.100	1
14 V DS	0.	.100	1
15 W DS	0.	.100	1
16 P DS	0.	.100	1
17 Q DS	0.	.100	1
18 H DS	0.	.100	1
19 HOLDS	0.	.100	1
20 P11DS	1.0000	.100	1
21 PAMIS	0.	.100	1
22 AL1US	30000.	.100	1

RATES AT OPERATING POINT

1 A1 OC	0.
2 X2 OC	0.
3 X3 OC	0.
4 X4 OC	0.
5 X5 OC	0.
6 X6 OC	0.
7 X7 OC	0.
8 X8 OC	0.
9 X9 OC	0.
10 X10OC	0.
11 A11OC	0.
12 IH ES	-4.8028
13 U DS	78.840
14 V DS	0.
15 W DS	0.
16 P DS	0.
17 Q DS	0.
18 H DS	0.
19 HOLDS	0.
20 P11DS	12.870
21 PAMIS	0.
22 AL1US	0.

13 ELEMENTS OF /MATIO/ DIFFER FROM 1 BY 10%. THESE ELEMENTS ARE PRECEDED BY AN \* IN THE STABILITY MATRIX

- MATIO( 1, 14) = -0.78623
- MATIO( 2, 14) = -9.21543
- MATIO( 3, 15) = 1.17382
- MATIO( 4, 14) = -895597
- MATIO( 6, 14) = .887882
- MATIO( 9, 14) = -2.83400
- MATIO( 11, 14) = -4.04543
- MATIO( 13, 14) = .506600
- MATIO( 15, 14) = .500000
- MATIO( 15, 19) = .500000
- MATIO( 17, 14) = .500000
- MATIO( 17, 16) = .500000
- MATIO( 17, 18) = .500000

STABILITY MATRIX

	X4 OC	X5 OC	V DS	W DS	P DS	X8 OC	X9 OC	X7 OC	X6 OC	X8 OC	X9 OC	X10OC	P11DS
X1 OC	X2 OC	X3 OC	X4 OC	X5 OC	V DS	W DS	P DS	X8 OC	X9 OC	X7 OC	X6 OC	X8 OC	X9 OC
1 X1 OC	1.756	0.	0.	0.	0.	0.	0.	0.	0.	0.	0.	0.	0.
2 X2 OC	-4.472	0.	0.	0.	0.	0.	0.	0.	0.	0.	0.	0.	0.
3 X3 OC	0.	0.	0.	0.	0.	0.	0.	0.	0.	0.	0.	0.	0.
4 X4 OC	0.	0.	0.	0.	0.	0.	0.	0.	0.	0.	0.	0.	0.
5 X5 OC	0.	0.	0.	0.	0.	0.	0.	0.	0.	0.	0.	0.	0.
6 X6 OC	0.	0.	0.	0.	0.	0.	0.	0.	0.	0.	0.	0.	0.
7 X7 OC	0.	0.	0.	0.	0.	0.	0.	0.	0.	0.	0.	0.	0.
8 X8 OC	0.	0.	0.	0.	0.	0.	0.	0.	0.	0.	0.	0.	0.
9 X9 OC	0.	0.	0.	0.	0.	0.	0.	0.	0.	0.	0.	0.	0.
10 X10OC	0.	0.	0.	0.	0.	0.	0.	0.	0.	0.	0.	0.	0.
11 A11OC	0.	0.	0.	0.	0.	0.	0.	0.	0.	0.	0.	0.	0.
12 IH ES	0.	0.	0.	0.	0.	0.	0.	0.	0.	0.	0.	0.	0.
13 U DS	0.	0.	0.	0.	0.	0.	0.	0.	0.	0.	0.	0.	0.
14 V DS	0.	0.	0.	0.	0.	0.	0.	0.	0.	0.	0.	0.	0.
15 W DS	0.	0.	0.	0.	0.	0.	0.	0.	0.	0.	0.	0.	0.
16 P DS	0.	0.	0.	0.	0.	0.	0.	0.	0.	0.	0.	0.	0.
17 Q DS	0.	0.	0.	0.	0.	0.	0.	0.	0.	0.	0.	0.	0.
18 H DS	0.	0.	0.	0.	0.	0.	0.	0.	0.	0.	0.	0.	0.
19 HOLDS	0.	0.	0.	0.	0.	0.	0.	0.	0.	0.	0.	0.	0.
20 P11DS	0.	0.	0.	0.	0.	0.	0.	0.	0.	0.	0.	0.	0.
21 PAMIS	0.	0.	0.	0.	0.	0.	0.	0.	0.	0.	0.	0.	0.
22 AL1US	0.	0.	0.	0.	0.	0.	0.	0.	0.	0.	0.	0.	0.

Figure 14 Linear Analysis Output

17 CC	1102E-01	-0.681	-2302E-04	-2277E-02	-1300E-04	-0000E-01	1600E-04	-7710E-07	-2774	-4130E-08
	2002E-01	0.	0.	2231E-04	-0371E-01	-1300E-04	0000E-01	1600E-04	7710E-07	-3300
18 CC	-4130E-08	-2932E-01	-134.0	1740E-06	1.310	-1004E-04	-12.30	-2002E-04	-0974E-01	
	0.	0.	0.	-1740E-06	-1.320	1004E-04	12.30	2002E-04	0974E-01	
19 CC	-4924E-01	1821E-08	8101E-03	-148.0	-9723E-03	2.487	-0.300E-02	-2700E-02	-120.7	4940E-03
	-1.727	0.004	-5.323E-01	148.0	9723E-03	-2.487	0.300E-02	2700E-02	120.7	-6091E-01
20 CC	-5193E-08	-5043	-090.0	1233E-01	-893.7	-0044E-03	-1000	-4103	-1704	-4112
	0.	0.	0.	-1233E-01	893.7	0044E-03	1000	4103	1704	4112
21 CC	-5397E-04	-1304	-2710E-04	-1.220	7329E-06	67.57	-1420E-03	4270	8040	-4160E-08
	0.	0.	0.	1.220	-7329E-06	-67.57	1420E-03	-4270	-8040	4160E-08
22 CC	1300E-01	-4400E-07	2142E-01	15.01	-2531E-01	-270.0	-2.200	-4700E-01	-3040	1197E-01
	-270.5	0.	-8344E-01	-15.01	2531E-01	270.0	2.200	4700E-01	3040	-5000
23 CC	-6179E-08	-4541E-01	50.14	-1400E-02	67.03	1470E-03	100.0	2000E-01	470.1	
	0.	0.	0.	1400E-02	-67.03	-1470E-03	-100.0	-2000E-01	-470.1	
24 CC	-1011E-02	1566E-01	-4017E-04	-3.150	-7231E-08	4270	-9004E-04	13.00	-1837E-01	-1160E-08
	0.	0.	0.	3.150	7231E-08	-4270	9004E-04	-13.00	1837E-01	1160E-08
25 CC	5570	-3737E-07	2624E-01	3130E-04	1900	-9070E-06	-9.110E-03	-10.22	-2730E-08	-1161E-02
	0.	0.	0.	-3130E-04	-1900	9070E-06	9.110E-03	10.22	2730E-08	1161E-02
26 CC	-1749E-08	1749E-08	7505E-08	3074E-01	-3130E-04	8040	8070E-06	1837E-01	10.22	2730E-08
	0.	0.	0.	-3074E-01	3130E-04	-8040	-8070E-06	-1837E-01	-10.22	-2730E-08
27 CC	-1161E-02	-1749E-08	2402E-08	-4800E-01	-4100E-08	4311	-1100E-06	-2730E-08	9.900	1702E-08
	0.	0.	0.	4800E-01	4100E-08	-4311	1100E-06	2730E-08	-9.900	-1702E-08
28 CC	-0019	0.	-3339	2402E-08	4800E-01	4100E-08	5000	-1100E-06	2730E-08	9.900
	0.	0.	0.	-2402E-08	-4800E-01	-4100E-08	-5000	1100E-06	-2730E-08	-9.900
29 CC	-1702E-08	0019	4824E-01	5190E-08	-1900E-01	8130E-08	4472	-1101E-02	1702E-08	-10.04
	0.	0.	0.	-5190E-08	1900E-01	-8130E-08	-4472	1101E-02	-1702E-08	10.04
30 CC	-1033E-07	-1033E-07	-3803E-08	-4924E-01	-5190E-08	1900E-01	-8130E-08	5070	1101E-02	-1702E-08
	0.	0.	0.	4924E-01	5190E-08	1900E-01	8130E-08	-5070	-1101E-02	1702E-08
31 CC	10.04	0.	2000E-08	-4950	4000E-07	-4541E-01	3737E-07	-1240E-08	11.81	1033E-07
	0.	0.	0.	4950	-4000E-07	4541E-01	-3737E-07	1240E-08	-11.81	-1033E-07
32 CC	-130.9	0.	-2932E-01	-2000E-08	-5043	-4600E-07	4641E-01	-2737E-07	-1240E-08	0015
	0.	0.	0.	2000E-08	5043	4600E-07	-4641E-01	2737E-07	1240E-08	-0015
33 CC	-2550	0014	8170E-03	8.007	2547E-03	-1877	2220E-02	-8223E-03	-82.90	3910E-02
	0.	0.	0.	-8.007	-2547E-03	1877	-2220E-02	8223E-03	82.90	-3910E-02
34 CC	-4.427	-1.000	0.	0.	0.	0.	0.	0.	0.	0.
35 CC	0.	0.	0.	0.	0.	0.	0.	0.	0.	0.
36 CC	0.	0.	0.	0.	0.	0.	0.	0.	0.	0.
37 CC	0.	0.	0.	0.	0.	0.	0.	0.	0.	0.
38 CC	0.	0.	0.	0.	0.	0.	0.	0.	0.	0.
39 CC	0.	0.	0.	0.	0.	0.	0.	0.	0.	0.
40 CC	0.	0.	0.	0.	0.	0.	0.	0.	0.	0.
41 CC	0.	0.	0.	0.	0.	0.	0.	0.	0.	0.
42 CC	0.	0.	0.	0.	0.	0.	0.	0.	0.	0.
43 CC	0.	0.	0.	0.	0.	0.	0.	0.	0.	0.
44 CC	0.	0.	0.	0.	0.	0.	0.	0.	0.	0.
45 CC	0.	0.	0.	0.	0.	0.	0.	0.	0.	0.
46 CC	0.	0.	0.	0.	0.	0.	0.	0.	0.	0.
47 CC	0.	0.	0.	0.	0.	0.	0.	0.	0.	0.
48 CC	0.	0.	0.	0.	0.	0.	0.	0.	0.	0.
49 CC	0.	0.	0.	0.	0.	0.	0.	0.	0.	0.
50 CC	0.	0.	0.	0.	0.	0.	0.	0.	0.	0.
51 CC	0.	0.	0.	0.	0.	0.	0.	0.	0.	0.
52 CC	0.	0.	0.	0.	0.	0.	0.	0.	0.	0.
53 CC	0.	0.	0.	0.	0.	0.	0.	0.	0.	0.
54 CC	0.	0.	0.	0.	0.	0.	0.	0.	0.	0.
55 CC	0.	0.	0.	0.	0.	0.	0.	0.	0.	0.
56 CC	0.	0.	0.	0.	0.	0.	0.	0.	0.	0.
57 CC	0.	0.	0.	0.	0.	0.	0.	0.	0.	0.
58 CC	0.	0.	0.	0.	0.	0.	0.	0.	0.	0.
59 CC	0.	0.	0.	0.	0.	0.	0.	0.	0.	0.
60 CC	0.	0.	0.	0.	0.	0.	0.	0.	0.	0.
61 CC	0.	0.	0.	0.	0.	0.	0.	0.	0.	0.
62 CC	0.	0.	0.	0.	0.	0.	0.	0.	0.	0.
63 CC	0.	0.	0.	0.	0.	0.	0.	0.	0.	0.
64 CC	0.	0.	0.	0.	0.	0.	0.	0.	0.	0.
65 CC	0.	0.	0.	0.	0.	0.	0.	0.	0.	0.
66 CC	0.	0.	0.	0.	0.	0.	0.	0.	0.	0.
67 CC	0.	0.	0.	0.	0.	0.	0.	0.	0.	0.
68 CC	0.	0.	0.	0.	0.	0.	0.	0.	0.	0.
69 CC	0.	0.	0.	0.	0.	0.	0.	0.	0.	0.
70 CC	0.	0.	0.	0.	0.	0.	0.	0.	0.	0.
71 CC	0.	0.	0.	0.	0.	0.	0.	0.	0.	0.
72 CC	0.	0.	0.	0.	0.	0.	0.	0.	0.	0.
73 CC	0.	0.	0.	0.	0.	0.	0.	0.	0.	0.
74 CC	0.	0.	0.	0.	0.	0.	0.	0.	0.	0.
75 CC	0.	0.	0.	0.	0.	0.	0.	0.	0.	0.
76 CC	0.	0.	0.	0.	0.	0.	0.	0.	0.	0.
77 CC	0.	0.	0.	0.	0.	0.	0.	0.	0.	0.
78 CC	0.	0.	0.	0.	0.	0.	0.	0.	0.	0.
79 CC	0.	0.	0.	0.	0.	0.	0.	0.	0.	0.
80 CC	0.	0.	0.	0.	0.	0.	0.	0.	0.	0.
81 CC	0.	0.	0.	0.	0.	0.	0.	0.	0.	0.
82 CC	0.	0.	0.	0.	0.	0.	0.	0.	0.	0.
83 CC	0.	0.	0.	0.	0.	0.	0.	0.	0.	0.
84 CC	0.	0.	0.	0.	0.	0.	0.	0.	0.	0.
85 CC	0.	0.	0.	0.	0.	0.	0.	0.	0.	0.
86 CC	0.	0.	0.	0.	0.	0.	0.	0.	0.	0.
87 CC	0.	0.	0.	0.	0.	0.	0.	0.	0.	0.
88 CC	0.	0.	0.	0.	0.	0.	0.	0.	0.	0.
89 CC	0.	0.	0.	0.	0.	0.	0.	0.	0.	0.
90 CC	0.	0.	0.	0.	0.	0.	0.	0.	0.	0.
91 CC	0.	0.	0.	0.	0.	0.	0.	0.	0.	0.
92 CC	0.	0.	0.	0.	0.	0.	0.	0.	0.	0.
93 CC	0.	0.	0.	0.	0.	0.	0.	0.	0.	0.
94 CC	0.	0.	0.	0.	0.	0.	0.	0.	0.	0.
95 CC	0.	0.	0.	0.	0.	0.	0.	0.	0.	0.
96 CC	0.	0.	0.	0.	0.	0.	0.	0.	0.	0.
97 CC	0.	0.	0.	0.	0.	0.	0.	0.	0.	0.
98 CC	0.	0.	0.	0.	0.	0.	0.	0.	0.	0.
99 CC	0.	0.	0.	0.	0.	0.	0.	0.	0.	0.
100 CC	0.	0.	0.	0.	0.	0.	0.	0.	0.	0.

Figure 14 Linear Analysis Output (Continued)

All negative real eigenvalues  
indicate a stable system.

22 EIGENVALUES		NATURAL FREQ.		DAMPING RATIO	
REAL	IMAGINARY				
1	-.441029E-01	0.	.441029E-01	1.00000	
2	-.331057	←- 2.48228	2.91113	.113721	
3	-.781057	←- 8.14752	9.78329	.777915	
4	-1.60070	0.	1.00070	1.00000	
5	-1.21515	←- .772786	1.44008	.843816	
6	-6.66369	0.	6.66369	1.00000	
7	-10.0724	0.	10.0724	1.00000	
8	-10.1134	0.	10.1134	1.00000	
9	-10.1247	0.	10.1247	1.00000	
10	-10.2259	0.	10.2259	1.00000	
11	-12.7877	0.	12.7877	1.00000	
12	-13.4785	0.	13.4785	1.00000	
13	-13.6496	0.	13.6496	1.00000	
14	-48.9533	0.	48.9533	1.00000	
15	-114.423	0.	114.423	1.00000	
16	-138.891	0.	138.891	1.00000	
17	-146.555	0.	146.555	1.00000	
18	-252.338	0.	252.338	1.00000	
19	-413.783	0.	413.783	1.00000	

333000 CPU SECONDS WERE REQUIRED FOR THE PREVIOUS ANALYSIS

\*\*\*\*\*  
COMMAND CARD

STEADY STATE

← COMMAND FOR NEXT ANALYSIS (TRIM)

Figure 14 Linear Analysis Output (Concluded)

STEADY STATE ANALYSIS  
 A MAXIMUM OF 30 ITERATIONS CAN BE USED

TIME = 0.		STATES		MATES		VARIABLES		PARAMETERS	
1. 81 OC	208.70	2. 82 OC	-4.5938	3. 83 OC	-4.4897E-04	4. 84 OC	-1.0.742	5. 85 OC	1.7174E-04
6. 86 OC	-5.8828	7. 87 OC	-4.0810E-04	8. 88 OC	-4.3895E-08	9. 89 OC	-2.8132	10. 90 OC	1.6075E-03
11. 811 OC	26.497	12. 812 OC	5.83.48	13. 813 OC	770.41	14. 814 OC	7.0672E-18	15. 815 OC	-1.6.427
16. 816 OC	7.0941E-21	17. 817 OC	4.5343E-18	18. 818 OC	9.3841E-23	19. 819 OC	2.9995E-18	20. 820 OC	-1.3.082
21. 821 OC	1.6562E-03	22. 822 OC	3.0627						
1. 81	1.9546E-08	2. 82	-1.0821E-04	3. 83	2.2010E-07	4. 84	-1.3290E-08	5. 85	-1.9271E-09
6. 86	-1.7348E-08	7. 87	-1.1002E-05	8. 88	-6.4051E-11	9. 89	-8.3375E-08	10. 90	-5.4941E-11
11. 811	-6.5977E-07	12. 812	3.6180E-11	13. 813	-7.1070E-08	14. 814	1.6851E-19	15. 815	3.2087E-08
16. 816	5.6154E-14	17. 817	9.5757E-08	18. 818	-6.4231E-18	19. 819	7.0870E-21	20. 820	4.5343E-18
21. 821	9.3895E-23	22. 822	-3.4173E-05						
1. 80 VA	720.41	2. 80 VA	705.72E-18	3. 80 VA	-1.6.427	4. 80 VA	7.0841E-21	5. 80 VA	4.6343E-18
6. 80 VA	9.3841E-23	7. 80 VA	3.0627	8. 80 VA	0.	9. 80 VA	0.	10. 80 VA	1.0000
11. 80 VA	0.	12. 80 VA	-1.3.082	13. 80 VA	-1.3.082	14. 80 VA	720.89	15. 80 VA	5.4112E-18
16. 80 VA	-1.6.427	17. 80 VA	-7.7052E-02	18. 80 VA	7.3348	19. 80 VA	1.8807E-18	20. 80 VA	32.186
21. 80 VA	37.375	22. 80 VA	297.50	23. 80 VA	175.78	24. 80 VA	724.37	25. 80 VA	-1.3748
26. 80 VA	-3.6464E-01	27. 80 VA	4.4697E-01	28. 80 VA	-7.9200	29. 80 VA	-8.5019E-01	30. 80 VA	8.7932E-01
31. 80 VA	-3.6.427	32. 80 VA	2.83.48	33. 80 VA	-1.3.082E-18	34. 80 VA	883.48	35. 80 VA	0.
36. 80 VA	-2.718.81	37. 80 VA	-1.42.72.85	38. 80 VA	-1.38.57E-05	39. 80 VA	-1.38.57E-05	40. 80 VA	-1.38.57E-05
41. 80 VA	-1.710.00E-05	42. 80 VA	47.80.00	43. 80 VA	32.987E-08	44. 80 VA	83.920	45. 80 VA	83.920
46. 80 VA	1.140.51E-19	47. 80 VA	52.14.00	48. 80 VA	1.144.00E-12	49. 80 VA	54.80.00	50. 80 VA	54.80.00
51. 80 VA	5.615.59E-14	52. 80 VA	57.00.00	53. 80 VA	9.675.72E-05	54. 80 VA	-1.22.34E-13	55. 80 VA	720.88
56. 80 VA		57. 80 VA		58. 80 VA		59. 80 VA	7.087.00E-21	60. 80 VA	7.087.00E-21
1. 81 VA	3.0000	2. 81 VA	726.00	3. 81 VA	0.	4. 81 VA	78.000	5. 81 VA	0.
6. 81 VA	0.	7. 81 VA	0.	8. 81 VA	0.	9. 81 VA	0.	10. 81 VA	0.
11. 81 VA	8.0000	12. 81 VA	1.0000	13. 81 VA	0.	14. 81 VA	1.0000	15. 81 VA	0.
16. 81 VA	-10.000	17. 81 VA	-3.7500	18. 81 VA	14.700	19. 81 VA	489.00	20. 81 VA	0.
21. 81 VA	1.0000	22. 81 VA	1.0000	23. 81 VA	0.	24. 81 VA	0.	25. 81 VA	0.
26. 81 VA	0.	27. 81 VA	0.	28. 81 VA	0.	29. 81 VA	0.	30. 81 VA	1.0000
31. 81 VA	0.	32. 81 VA	0.	33. 81 VA	0.	34. 81 VA	0.	35. 81 VA	0.
36. 81 VA	0.	37. 81 VA	0.	38. 81 VA	0.	39. 81 VA	1.0000	40. 81 VA	0.
41. 81 VA	0.	42. 81 VA	0.	43. 81 VA	0.	44. 81 VA	0.	45. 81 VA	0.
46. 81 VA	0.	47. 81 VA	0.	48. 81 VA	0.	49. 81 VA	1.0000	50. 81 VA	0.
51. 81 VA	0.	52. 81 VA	0.	53. 81 VA	0.	54. 81 VA	1.0000	55. 81 VA	0.
56. 81 VA	0.	57. 81 VA	0.	58. 81 VA	0.	59. 81 VA	1.0000	60. 81 VA	0.
61. 81 VA	0.	62. 81 VA	0.	63. 81 VA	0.	64. 81 VA	0.	65. 81 VA	0.
66. 81 VA	0.	67. 81 VA	0.	68. 81 VA	0.	69. 81 VA	0.	70. 81 VA	0.
71. 81 VA	0.	72. 81 VA	0.	73. 81 VA	0.	74. 81 VA	0.	75. 81 VA	0.
76. 81 VA	0.	77. 81 VA	0.	78. 81 VA	0.	79. 81 VA	0.	80. 81 VA	0.
81. 81 VA	0.	82. 81 VA	0.	83. 81 VA	0.	84. 81 VA	0.	85. 81 VA	0.
86. 81 VA	0.	87. 81 VA	0.	88. 81 VA	0.	89. 81 VA	0.	90. 81 VA	0.
91. 81 VA	0.	92. 81 VA	0.	93. 81 VA	0.	94. 81 VA	0.	95. 81 VA	0.
96. 81 VA	0.	97. 81 VA	0.	98. 81 VA	0.	99. 81 VA	0.	100. 81 VA	0.

**AILERON DEFL.**

**ELEVATOR DEFLECTION**

**ENGINE THRUST**

SYSTEM EIGENVALUES AT THIS OPERATING POINT

27 EIGENVALUES

Figure 15 Trim Condition Determined by the O.C.

	REAL	IMAGINARY	NATURAL FREQ.	DAMPING RATIO
1	-.484314E-01	0.	.484314E-01	1.00000
2	-.314361	2.97708	2.99384	.105018
3	-.670775	1.15200	1.33192	.502860
4	-.978640	-.83253E-01	.880101	.918530
5	-1.01115	0.	1.01115	1.00000
6	-7.75805	0.	7.25805	1.00000
7	-9.90121	0.	9.90121	1.00000
8	-10.0775	-.389141	10.0854	.999755
9	-10.8848	-.2.54554	11.1785	.973777
10	-13.5533	0.	13.5533	1.00000
11	-14.5017	0.	14.5017	1.00000
12	-47.5574	0.	47.5574	1.00000
13	-115.073	0.	135.073	1.00000
14	-136.654	0.	136.654	1.00000
15	-145.528	0.	145.528	1.00000
16	-257.691	0.	257.691	1.00000
17	-414.778	0.	414.778	1.00000

.360000 CPU SECONDS WERE REQUIRED FOR THE PREVIOUS ANALYSIS

FORMING CARD -----

NIC-N



← UPDATING THE INITIAL CONDITION VECTOR FOR NEXT ANALYSIS

Figure 15 Trim Condition Determined By The O.C. (Concluded)

Notice that the state derivatives (RATES) are all driven to very small values in Figure 15. After the steady state analysis, the XIC-X command causes the trim values of the states to replace the original initial conditions (see Figure 16).

The next command PRINTER PLOTS causes the on line printer to be turned on while the PLOT ON part of the command requests the off line printer e.g. CALCOMP or SC4020 to be turned on. The PLOT TABLES command causes an off line plotting of the named tables (data inputs). Figure 17 shows a sample (one of the five) table plot. Figure 18 shows a portion of the printout of a STEADY SCAN analysis for a down wind velocity. The off line plotted results of the STEADY SCAN analysis are shown in Figure 19 while Figure 20 shows the corresponding printer plot output (on line) for AL VA (angle of attack).

All states except the longitudinal states are then frozen out in order to simulate the free longitudinal aircraft, see Figure 21. The commands starting with DISPLAY1 and ending with ALTDS, VS, TIME specify the time histories to be plotted. The command LINEAR ANALYSIS gives the pole locations for the free airplane, and the commands TINC = .1 plus the command SIMULATE produce the time history simulations. (Note that the perturbation is specified by setting the initial condition W DS = 60).

The results of the LINEAR ANALYSIS and part of the printout from the simulation are shown in Figures 22 and 23. The time history plots of alpha, W, U, Q and pitch for this case are shown in Figure 24. The short period transient dies out after about 4 seconds, while U and pitch oscillate slowly at the phugoid mode. Figure 25 shows the corresponding printer plot output for AL VA (angle of attack).

Another STEADY SCAN analysis is requested for a side wind velocity parameter (VW CA) and the results are shown in Figure 26. This is followed by a LINEAR ANALYSIS and a SIMULATION of the free lateral airplane where all states except the lateral states are frozen out (for commands see Figure 10). The results of the LINEAR ANALYSIS are shown in Figure 27 while the time history plots of beta, R, P, altitude and roll are shown in Figure 28. Note that roll angle settles to a 1.30 degrees offset due to the spiral divergence mode.

INITIAL CONDITIONS/OPERATING POINT

1 R1 OC	=	208.2	2 R2 OC	=	-8.894	3 R3 OC	=	-4884E-04	4 R4 OC	=	-10.74	5 R5 OC	=	.1717E-04
6 R6 OC	=	-8.643	7 R7 OC	=	-4001E-04	8 R8 OC	=	.4354E-05	9 R9 OC	=	-2.813	10 R10 OC	=	.1003E-03
11 R11 OC	=	26.50	12 T1 ES	=	883.5	13 U DS	=	770.4	14 V DS	=	.7007E-18	15 W DS	=	-10.43
16 P DS	=	.7094E-21	17 Q DS	=	.4534E-18	18 R DS	=	.9384E-23	19 HOLD5	=	.2899E-18	20 P1TOS	=	-1.308
21 VMEZ	=	.1856E-03	22 AL TUS	=	.3003E-08									

PRINTER PLOTS, PLOT ON	←	ON LINE, OFF LINE PLOTTERS ON
PLOT 16=	M.S.E. 47-03	
PLOT TABLES=CLTAC, CRTAC, CRTAC, CHBAC, CLBAC	←	OFF LINE PLOTS ONLY
DISPLAY		
AL VA, VS, WR VA		BOTH ON LINE AND OFF LINE PLOTS
P1TOS, VS, WR VA		
F2ZOL, VS, WR VA		
F2ZOL, VS, WR VA		
TYZOL, VS, WR VA		
TITLE	STEADY SCAN, LONGITUDINAL MOTION	
SS PARAMETER=WR VA, SS START=40, SS STOP=0		SS SCAN COMMANDS
SS POINTS=5, STEADY STATE		

Figure 16 Playback of Commands for Plotting and Scan

Note: In actual output four more plots will follow (see Figure 16)

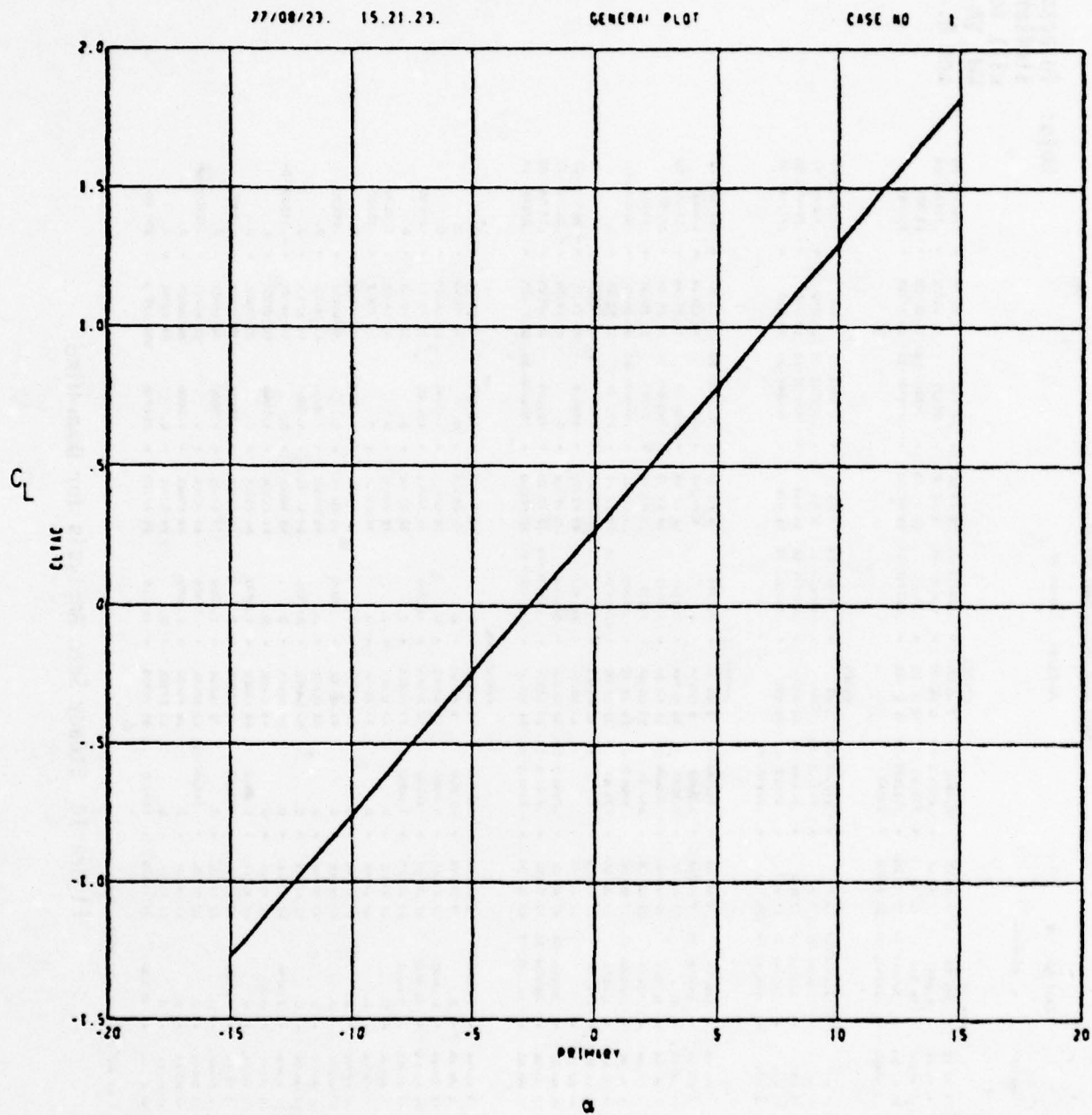

Figure 17 Input Table Plot,  $C_L$  vs  $\alpha$

NUMBER OF ITERATIONS CAN BE USED PER ANALY

STEADY STATE ANALYSIS

DATE: 10/20/74, TIME: 20.08.20.

Note: In actual listing similar printouts will follow for WH VA = 30., 20., 10. and 0.

Table with columns for CASE NO., TIME, STATES, RATES, VARIABLES, and PARAMETER. Rows include various node identifiers like 1 41 GC, 1 42 GC, etc., with associated numerical values.

Figure 18 Steady Scan Analysis for Down-Wind

STEADY-SCAN LONGITUDINAL MOTION

77/08/23. 15.21.23.

STEADY STATE DISPLAY 1

CASE NO. 0

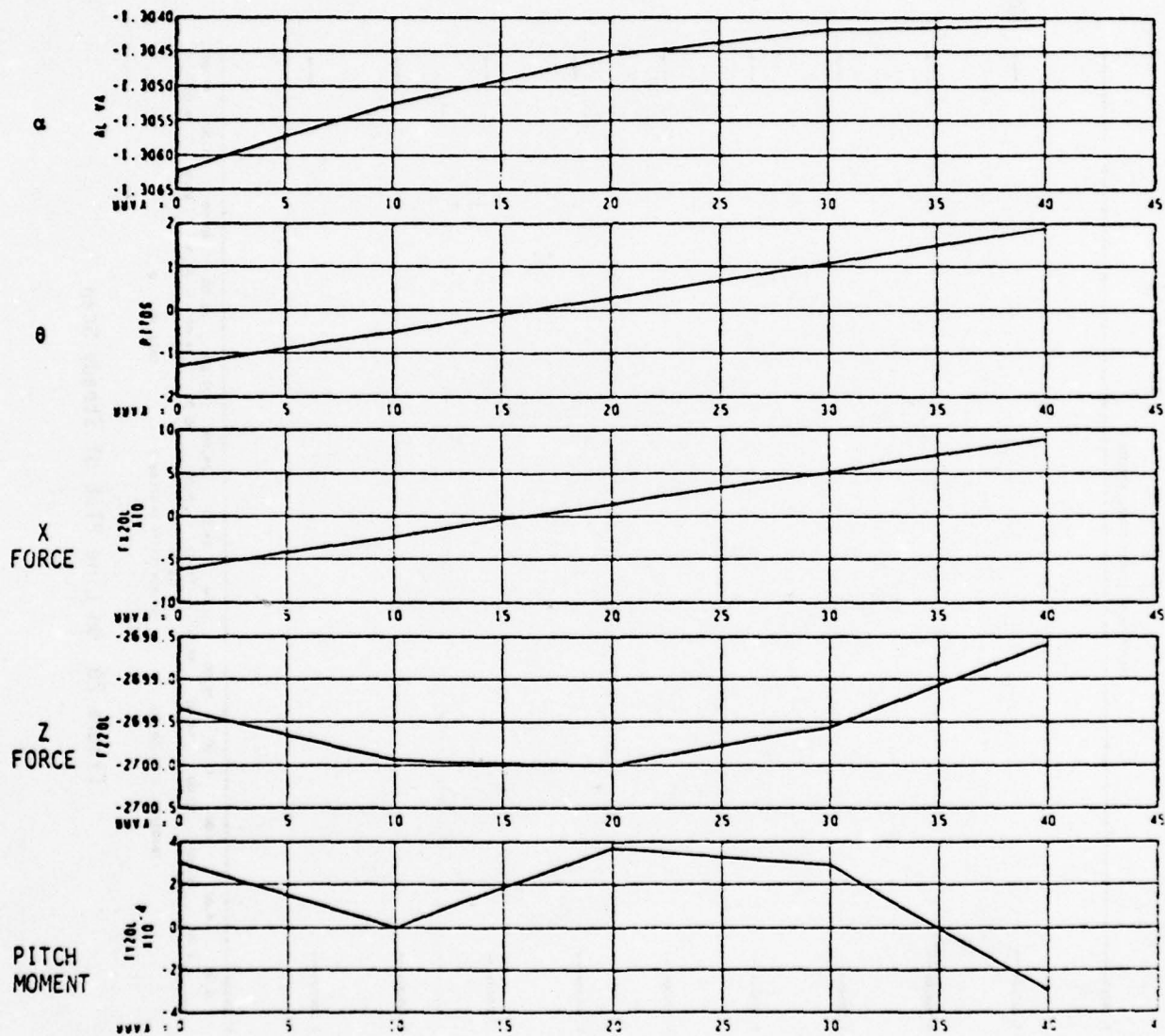
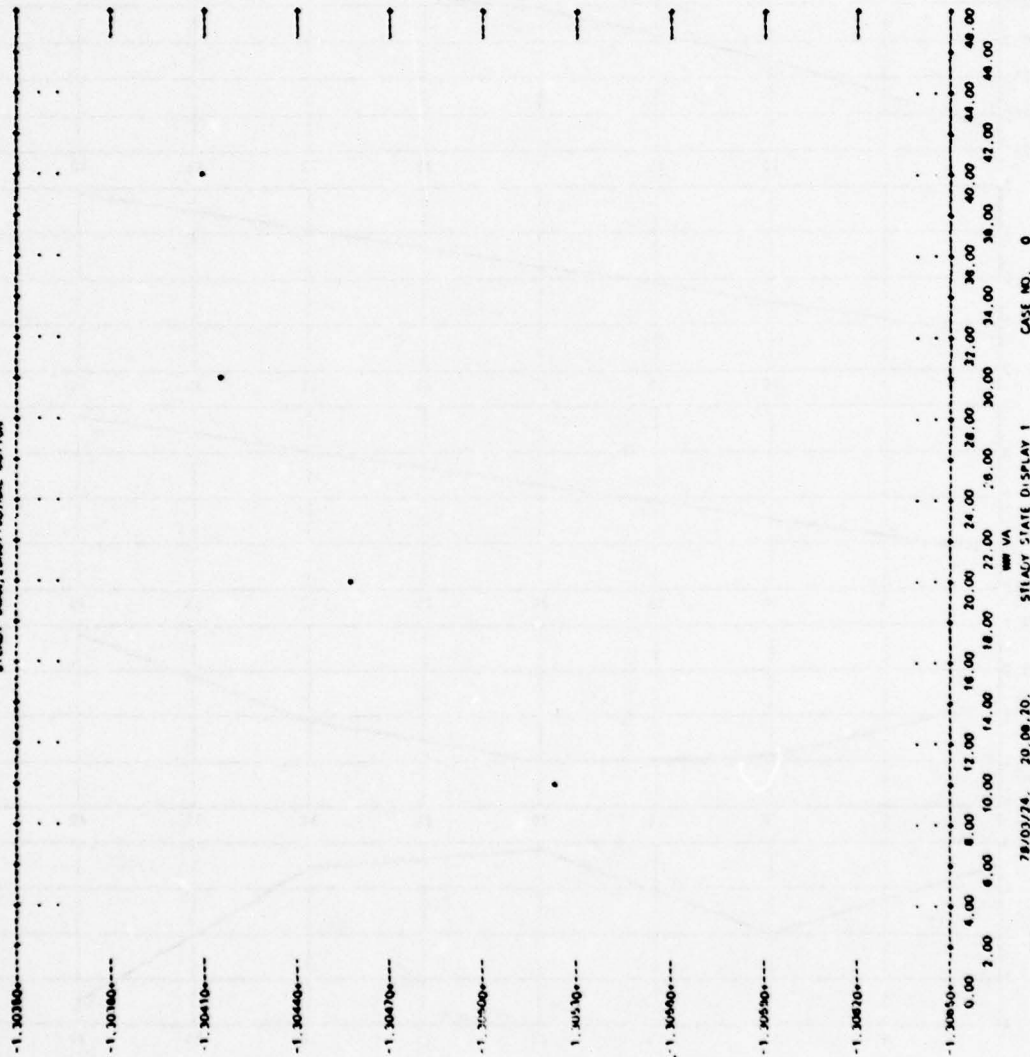

Figure 19 Off Line Plots of Down-Wind Steady Scan

STEADY SCAN, LONGITUDINAL MOTION



Note: In actual listing  
four more plots  
will follow per  
DISPLAY1 COMMAND.  
See Figure 16

78/03/74. 20.06.70. STEADY STATE DISPLAY 1 CASE NO. 0

Figure 20 On Line Plot of Steady Scan

```

16 XD ES = -10.900
21 1PWF = 1.0000
24 ALAL = 0.
31 ZA OL = 0.
36 ZTHA = 0.
41 MUGA = 0.
46 MTHA = 0.
51 MPA = 3.0000
54 1H DL = 0.
56 4H DL = 0.
71 LP DL = -.37000
76 LTHA = 0.
81 MHA = 0.
91 MHA = 0.
94 B DL = 19.000

18 PAMES = 14.700
23 PATES = 1.0000
28 XPOL = 0.
33 ZPOL = 0.
38 ZGOL = 0.
43 MJ OL = -.24000
46 MTEOL = 0.
51 MTOOL = 0.
54 C OL = 63.820
55 YBOL = 0.
61 YUOL = 0.
66 YVOL = 1.0000
71 LPOL = 0.
76 LCOL = 1.0000
81 MH DL = -.10420
86 MCOL = 1.0000
91 FYDL = 0.
94 FYDL = 0.
98 1YDUS = 1811.0

19 TAMES = 489.00
24 MA OL = 0.
29 RIGOL = 0.
34 ZU OL = 0.
39 KZBOL = 1.0000
44 MJ OL = 0.
49 MHPOL = 1.0000
54 C OL = 4.0000
55 YBOL = 0.
61 YUOL = 1.0000
66 YVOL = 0.
71 LPOL = -.14184
76 LCOL = 1.0000
81 MH DL = 0.
86 MCOL = 0.
91 FYDL = 1.0000
94 FYDL = 0.
98 1YDUS = 2840.0

20 P2 ES = .99999
26 MU OL = 0.
30 KXBOL = 1.0000
35 ZDEOL = .25940
40 ZDSOL = 0.
45 MOPOL = .84200
50 MFSOL = 0.
55 MPTOL = 0.
60 YP DL = -.21800E-01
65 YTRD = 0.
70 LBOL = 0.
75 FCLDL = 1.0000
80 LHOL = 0.
85 MKAOL = .15200E-01
90 MHOL = 0.
95 TZIDL = 0.
100 1KZDUS = -200.00

```

END OF STEADY SCAN ANALYSIS

CPU SECONDS WERE REQUIRED FOR THE PREVIOUS ANALYSIS

SS PARAMETER=NONE ← TURNING OFF STEADY SCAN

REPLACING STEADY SCAN  
PARAMETERS WITH VARIABLES  
FOR TIME HISTORY SIMULATION

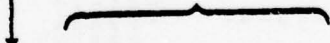

```

SS PARAMETER=NONE ←
DISPLAY
AL VA, VS, TIME
W DS, VS, TIME
U DS, VS, TIME
O DS, VS, TIME
PITDS, VS, TIME
DISPLAY2
ALTDG, VS, TIME

```

```

TIME = 1, TMAX = 12, RATE = 10 ← REQUESTING PRINTOUT EVERY (.1*10=1.) SECOND
NO STATES ← Freezing all states; Taking O.C. out
INT CONTROL = W DS = 1, U DS = 1, O DS = 1, PITDS = 1, ALTDG = 1 ← Unfreezing Longitudinal states
TITLE FREE LONGITUDINAL MODEL, NONDIM. DATA
LINKAN ANALYSIS ← Next Analysis

```

Figure 21 Playback of Input Commands for Next Analysis

STATE NAME	OPERATING POINT	PERTURBATION SIZE	INTEGRATOR CONTROL
1 K1 OC	208.20	.100	0
2 K2 OC	-4.8934	.100	0
3 K3 OC	-4857E-04	.100	0
4 K4 OC	-16.742	.100	0
5 K5 OC	.11174E-04	.100	0
6 K6 OC	-5.6876	.100	0
7 K7 OC	-4.0810E-04	.100	0
8 K8 OC	4.3055E-05	.100	0
9 K9 OC	-2.5132	.100	0
10 P1 UDS	.16055E-03	.100	0
11 K11 OC	26.497	.100	0
12 K12 OC	583.48	.100	0
13 U U5	720.41	.100	1
14 V U5	.70572E-18	.100	0
15 W U5	-16.427	.100	1
16 P U5	.70941E-21	.100	0
17 U U5	-45.145E-18	.100	1
18 R U5	9.3841E-23	.100	0
19 M4 U5	.29995E-18	.100	1
20 P1 UDS	-1.3062	.100	0
21 VAMU5	.18547E-03	.100	0
22 A1 U5	30627.	.100	1

RATES AT OPERATING POINT

1 K1 OC	.19648E-08	2 K2 OC	.16831E-04	3 K3 OC	.27010E-07	4 K4 OC	-.15290E-08	5 K5 OC	-.19371E-
6 K6 OC	.17334E-08	7 K7 OC	-.10029E-08	8 K8 OC	-.64051E-11	9 K9 OC	-.83378E-08	10 K10 OC	-.84981E-
11 K11 OC	-.89407E-07	12 K12 OC	.38380E-11	13 U U5	-.71070E-08	14 V U5	.14681E-18	15 W U5	.37087E-
16 P U5	.56159E-14	17 U U5	.95257E-06	18 R U5	-.64231E-18	19 M4 U5	.70920E-21	20 P1 UDS	.45343E-
21 VAMU5	.83805E-23	22 A1 U5	-.34128E-06						

STABILITY MATRIX

U DS	W DS	O DS	P1 UDS	A1 U5	DAMPING RATIO
U DS	-.2133E-01	-.4848E-03	.2887	-.6814	.2716E-03
W DS	-.1283	-1.708	12.57	-.1231E-01	.1138E-02
U U5	-.7712E-02	-1.181	-.2843E-01	0.	-.2445E-03
P1 UDS	0.	0.	1.000	0.	0.
A1 U5	-.2280E-01	-.9887	0.	12.88	0.

B EIGENVALUES

REAL	IMAGINARY	NATURAL FREQ.	DAMPING RATIO	
1	.31981E-07	0.	.31981E-07	-1.0000
2	-.87284E-02	+.81477E-01	.87004E-01	.11328
3	-.88814E-02	+.3.7604E-01	3.8694E-01	.22507

Phugoid; t = 77 sec

SHORT PERIOD; t=1.63 sec

4800004-01 CPU SECONDS WERE REQUIRED FOR THE PREVIOUS ANALYSIS

Figure 22 Jindivik Free Longitudinal Linear Analysis

PERTURBATION FROM STEADY STATE

PRINT RATE= 10 DISPLAY RATE= 1 MODE= 1 TIME= .10000 TIME= 12.000

FREE LONGITUDINAL MODEL, NOMINAL DATA

CASE NO. 7 76/03/24. 20.06.24. INITIAL CONDITION# 05=00 SIMULATE

TIME = 0.

1 RI OC	= 206.20	2 R2 OC	= -4.8838	3 R3 OC	= -.48857E-04	4 R4 OC	= -16.742	5 R5 OC	= .17174E-04
6 R6 OC	= -5.6828	7 R7 OC	= -.40810E-04	8 R8 OC	= -.43855E-08	9 R9 OC	= -2.8132	10 R10 OC	= .16038E-03
11 R11 OC	= 26.497	12 R12 ES	= 683.46	13 U DS	= 720.41	14 V DS	= .70972E-18	16 W DS	= 60.000
16 P DS	= .70941E-21	17 Q DS	= .48343E-18	18 R DS	= .53841E-23	19 ROLDS	= .28995E-18	20 P1TDS	= -1.3062
21 VAW.S	= .16502E-03	22 ALTDS	= 30027.						

RATES

1 R1	= 0.	2 R2	= 0.	3 R3	= 0.	4 R4	= 0.	5 R5	= 0.
6 R6	= 0.	7 R7	= 0.	8 R8	= 0.	9 R9	= 0.	10 R10	= 0.
11 R11	= 0.	12 R12	= 0.	13 R13	= -4.6345	14 R14	= 0.	15 R15	= -131.87
16 R16	= 0.	17 R17	= -84.359	18 R18	= 0.	19 R19	= 0.	20 R20	= .48343E-18
21 R21	= 0.	22 R22	= -78.407						

VARIABLES

1 LC VA	= 720.41	2 VO VA	= .70972E-18	3 MO VA	= 60.000	4 PO VA	= .70841E-21	5 CO VA	= .48343E-18
6 MO VA	= .53841E-23	7 ID2VA	= 3.0000	8 OM2VA	= 0.	9 HM2VA	= 0.	10 CALVA	= 1.0000
11 CALVA	= 0.	12 AL VA	= 4.7810	13 ALPVA	= 4.7810	14 VT VA	= 722.80	15 BE VA	= .85934E-18
16 W VA	= 60.000	17 UP VA	= -.77055E-02	18 EU VA	= .73345	19 EV VA	= .18901E-18	20 EW VA	= 32.166
21 S1VA	= .37375	22 OS VA	= 264.40	23 OS VA	= 17841.	24 M2VA	= .72689	25 ZO AC	= -.76238
26 NO AC	= -.50613E-01	27 M2 AC	= 62572E-02	28 V8 AC	= -.75600	29 I8 AC	= -13389	30 M8 AC	= .49208E-01
31 O1 AC	= -3.6541	32 O2 AC	= 583.46	33 O3 AC	= -.13878E-18	34 I4 ES	= 583.46	35 F7 ES	= 0.
36 F7 ES	= -218.81	37 F5 ES	= -1	38 F5 ES	= -1	39 PPOES	= -1	40 TPOES	= -1
41 R2 ES	= -4.6145	42 I2 ES	= -131.87	43 EXZOL	= -450.48	44 FZOL	= -13741.	45 FYZOL	= -2868.4
46 M2 OL	= 6.1891E	47 M2 OL	= -11611E-12	48 M2 OL	= 83.970	49 M2 OL	= 0.	50 FYZOL	= -.17918E-18
51 M2 OL	= .15108E-18	52 I2 OL	= -12317E-13	53 I2 OL	= -12317E-13	54 M2 DS	= 718.88	55 YD DS	= .20705E-02
56 M2 DS	= 0.	57 O3 DS	= -84.359	58 M2 DS	= 0.	59 M2 DS	= 0.	60 P1DOES	= .45343E-18

PARAMETERS

1 AL2VA	= 3.0000	2 V5 VA	= 726.00	3 AL2VA	= 0.	4 S VA	= 78.000	5 LW VA	= 0.
6 LW VA	= 0.	7 W8 VA	= 0.	8 W8 VA	= 0.	9 OM1VA	= 0.	10 RM1VA	= 0.
11 AL2VA	= 6.0000	12 ICRS	= 1.0000	13 AMP.S	= 0.	14 GATES	= 1.0000	16 GATES	= 0.
17 P2 ES	= -10.960	18 P2 ES	= -37500	19 PAME.S	= 14.700	20 P2 ES	= 489.00	20 P2 ES	= .98999
21 I1ES	= 1.0000	22 I1ES	= 1.0000	23 I1ES	= 0.	24 M2 OL	= 0.	25 M2 OL	= 0.
26 R2OL	= 0.	27 R2OL	= 0.	28 R2OL	= 0.	29 R2OL	= 0.	30 R2OL	= 1.0000
31 Z4OL	= 0.	32 Z4OL	= 0.	33 Z4OL	= 0.	34 Z4OL	= 0.	35 Z4OL	= .25940
36 Z4OL	= 0.	37 Z4OL	= 0.	38 Z4OL	= 0.	39 R7BOL	= 1.0000	40 ZUPAL	= 0.
41 M2 OL	= 0.	42 M2 OL	= 0.	43 M2 OL	= -.74800	44 M2 OL	= 0.	45 M2 OL	= .84200
46 M2 OL	= 0.	47 M2 OL	= 0.	48 M2 OL	= 0.	49 M2 OL	= 1.0000	50 M2 OL	= 0.
51 M2 OL	= 0.	52 M2 OL	= 0.	53 M2 OL	= 83.870	54 C OL	= 4.0000	55 M2 OL	= 0.
56 M2 OL	= 0.	57 M2 OL	= 0.	58 M2 OL	= 0.	59 M2 OL	= 0.	60 M2 OL	= -.21500E-01
61 M2 OL	= 0.	62 M2 OL	= 0.	63 M2 OL	= 0.	64 M2 OL	= 1.0000	65 M2 OL	= 0.
66 M2 OL	= 0.	67 M2 OL	= 0.	68 M2 OL	= 1.0000	69 M2 OL	= 0.	70 M2 OL	= 0.
71 M2 OL	= -.271000	72 M2 OL	= .44980	73 M2 OL	= 0.	74 M2 OL	= -.14184	75 M2 OL	= 1.0000
76 M2 OL	= 0.	77 M2 OL	= 0.	78 M2 OL	= 1.0000	79 M2 OL	= 1.0000	80 M2 OL	= 0.
81 M2 OL	= 0.	82 M2 OL	= .16700E-02	83 M2 OL	= -15.650	84 M2 OL	= 0.	85 M2 OL	= .15200E-01
86 M2 OL	= 0.	87 M2 OL	= 0.	88 M2 OL	= 1.0000	89 M2 OL	= 1.0000	90 M2 OL	= 0.
91 M2 OL	= 0.	92 M2 OL	= 0.	93 M2 OL	= 0.	94 M2 OL	= 0.	95 M2 OL	= 0.
96 M2 OL	= 19.0000	97 M2 OL	= 1190.0	98 M2 OL	= 1811.0	99 M2 OL	= 2840.0	100 M2 OL	= -200.00

UNWIND BACK TO RANGE-NUTIA METHOD FOR 100 STEPS AT TIME= .33648 STEP SIZE= .10765E-01 ORDER= 4 RELATIVE ERRORS

Figure 23 Jindivik Free Longitudinal Simulation

FREE LONGITUDINAL MODEL NONDIM DATA

77/08/23 15.21.25

SIMULATION DISPLAY 1

CASE NO. 7

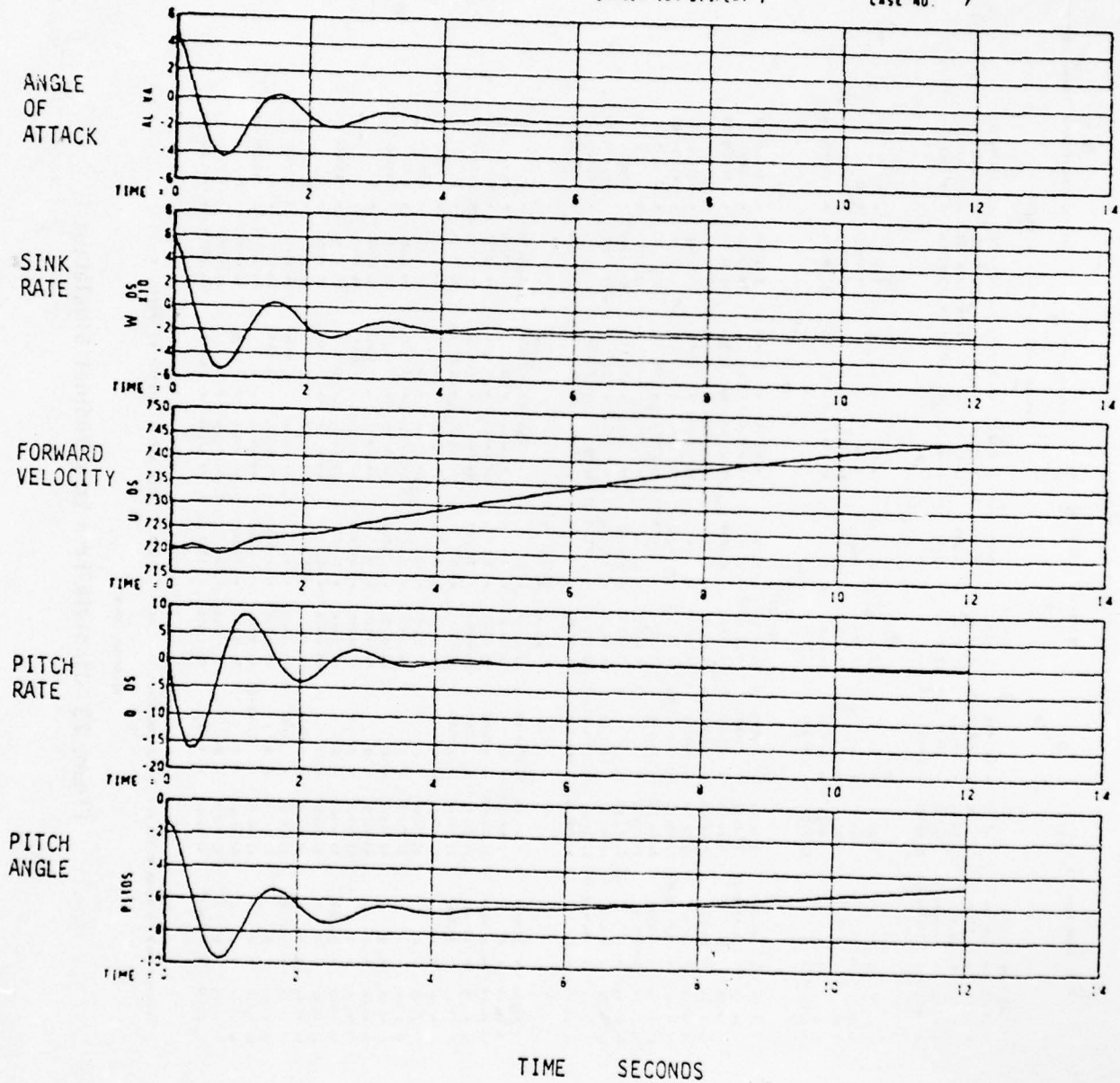

Figure 24 Jindivik Free Longitudinal Time History Plots

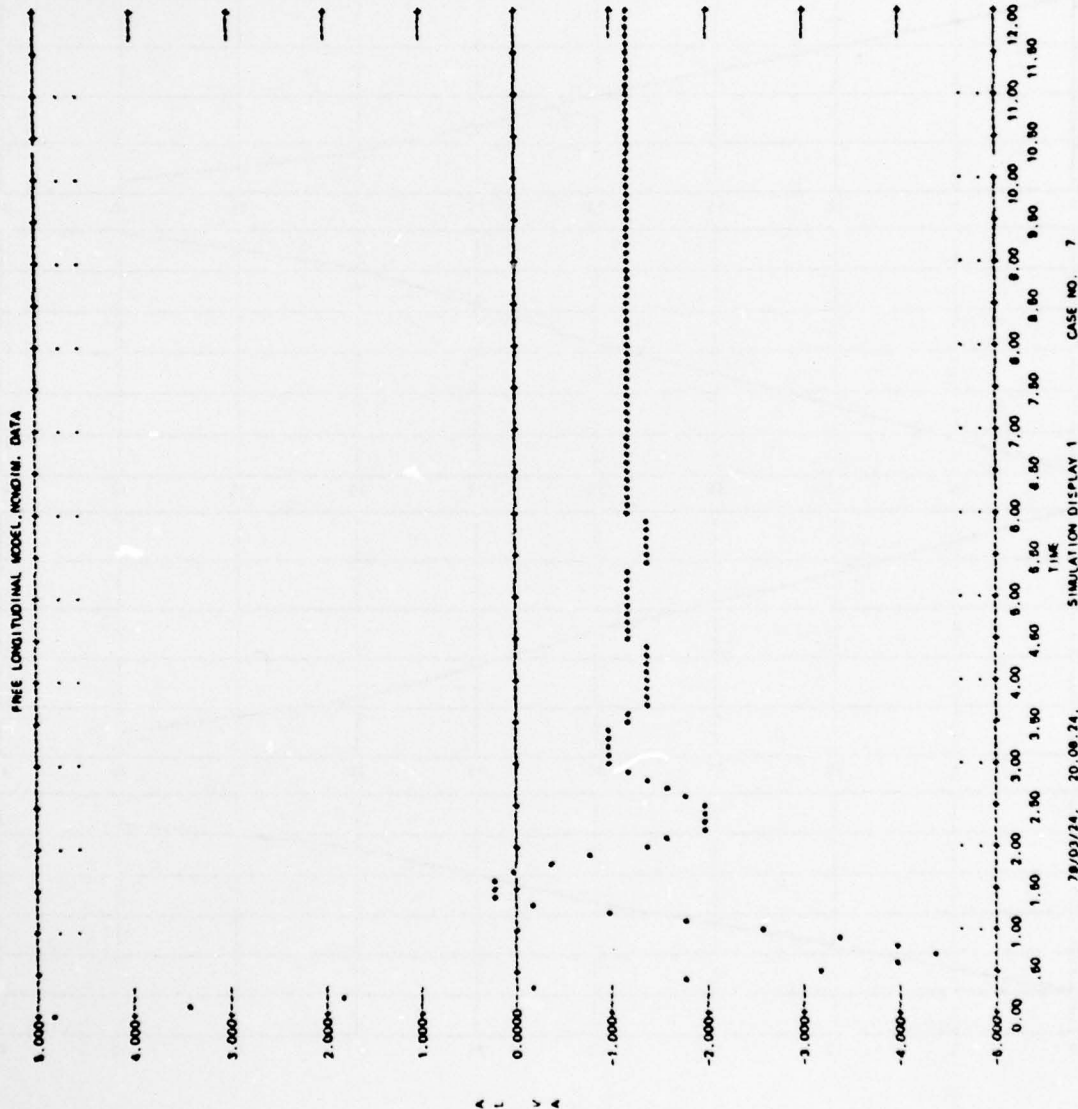

Figure 25 Free Longitudinal Time History On Line Plot Example

STEADY SCAN LATERAL MOTION

77/00/23. 15.21.35.

STEADY STATE DISPLAY 1

CASE NO. 0

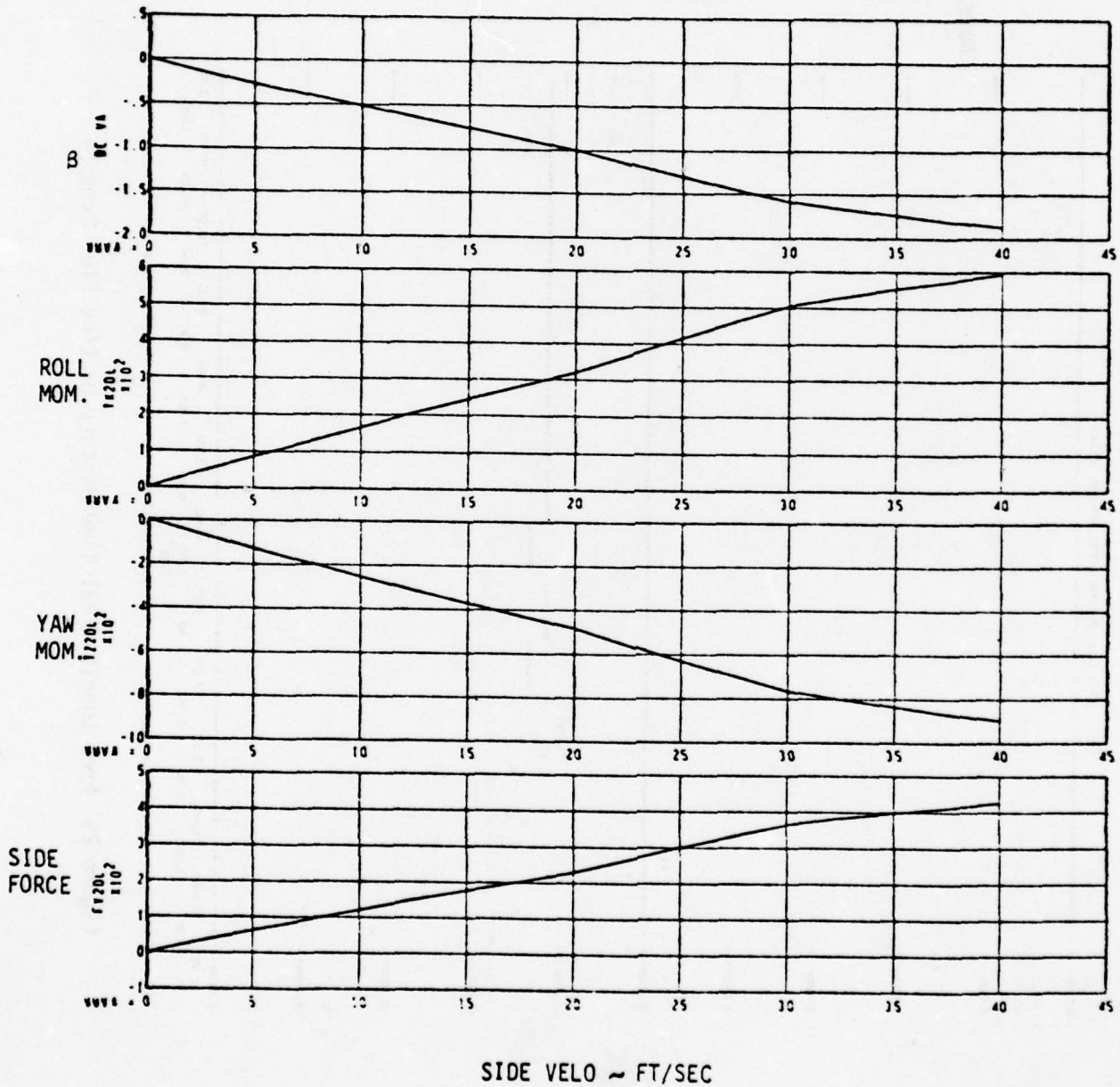

Figure 26 Off Line Plots of Side-Wind Steady Scan

LINEAR ANALYSIS (P/P)

STATE NAME	OPERATING POINT	PERTURBATION SIZE	INTEGRATOR CONTROL
1 X1 OC	208.20	.100	0
2 X2 OC	-4.5938	.100	0
3 X3 OC	-.48557E-04	.100	0
4 X4 OC	-16.747	.100	0
5 X5 OC	.17174E-04	.100	0
6 X6 OC	-5.8876	.100	0
7 X7 OC	.40810E-04	.100	0
8 X8 OC	-4.3895E-05	.100	0
9 X9 OC	-2.5137	.100	0
10 X10 OC	.16035E-03	.100	0
11 X11 OC	26.497	.100	0
12 X12 OC	581.48	.100	0
13 U US	770.41	.100	0
14 V VS	.70572E-18	.100	1
15 W WS	-16.430	.100	0
16 P PS	.70941E-21	.100	1
17 Q QS	.45143E-18	.100	0
18 R RS	.93841E-23	.100	1
19 PA US	.29995E-18	.100	1
20 P11 DS	-1.3062	.100	0
21 PAMB US	.16562E-03	.100	0
22 AL US	30027.	.100	0

RATES AT OPERATING POINT

1 X1 OC	.18843E-04	2 X2 OC	.68802E-03	3 X3 OC	.88718E-08	4 X4 OC	.644970	5 X5 OC	-.28650E-
6 X6 OC	-.28578E-03	7 X7 OC	.19815E-07	8 X8 OC	.88204E-07	9 X9 OC	-.17739E-03	10 X10 OC	.13417E-
11 X11 OC	.15730E-07	12 X12 OC	.38380E-11	13 U US	-.88281E-08	14 V VS	.14881E-18	15 W WS	.83388E-
16 P PS	.86159E-14	17 Q QS	.38982E-02	18 R RS	-.84231E-18	19 M OLS	.70920E-21	20 P11 DS	.45343E-
21 PAMB US	.91865E-23	22 AL US	.31193E-02						

STABILITY MATRIX

V DS	P DS	R DS	M OLS
1	-.2174	-.2878	-12.87
2	-1.370	-1.382	1.720
3	.8098	.9990E-01	-.3800
4	0.	1.000	-.2780E-01
5			-.1805E-21

4 EIGENVALUES

REAL	IMAGINARY	NATURAL FREQ.	DAMPING RATIO
1	.387503E-01	0.	-1.00000
2	-.286514	+.3.22841	.884003E-01
3	-1.47303	0.	1.00000

SPIRAL DIVERGENCE  
DUTCH ROLL  
ROLL SUBSIDENCE

410060E-01 CPU SECONDS WERE REQUIRED FOR THE PREVIOUS ANALYSIS

Figure 27 Jindivik Free Lateral Linear Analysis

FREE LATERAL MODEL (STABILITY AXIS DATA)

77/08/23 15.21.41.

SIMULATION DISPLAY 1

CASE NO. 9

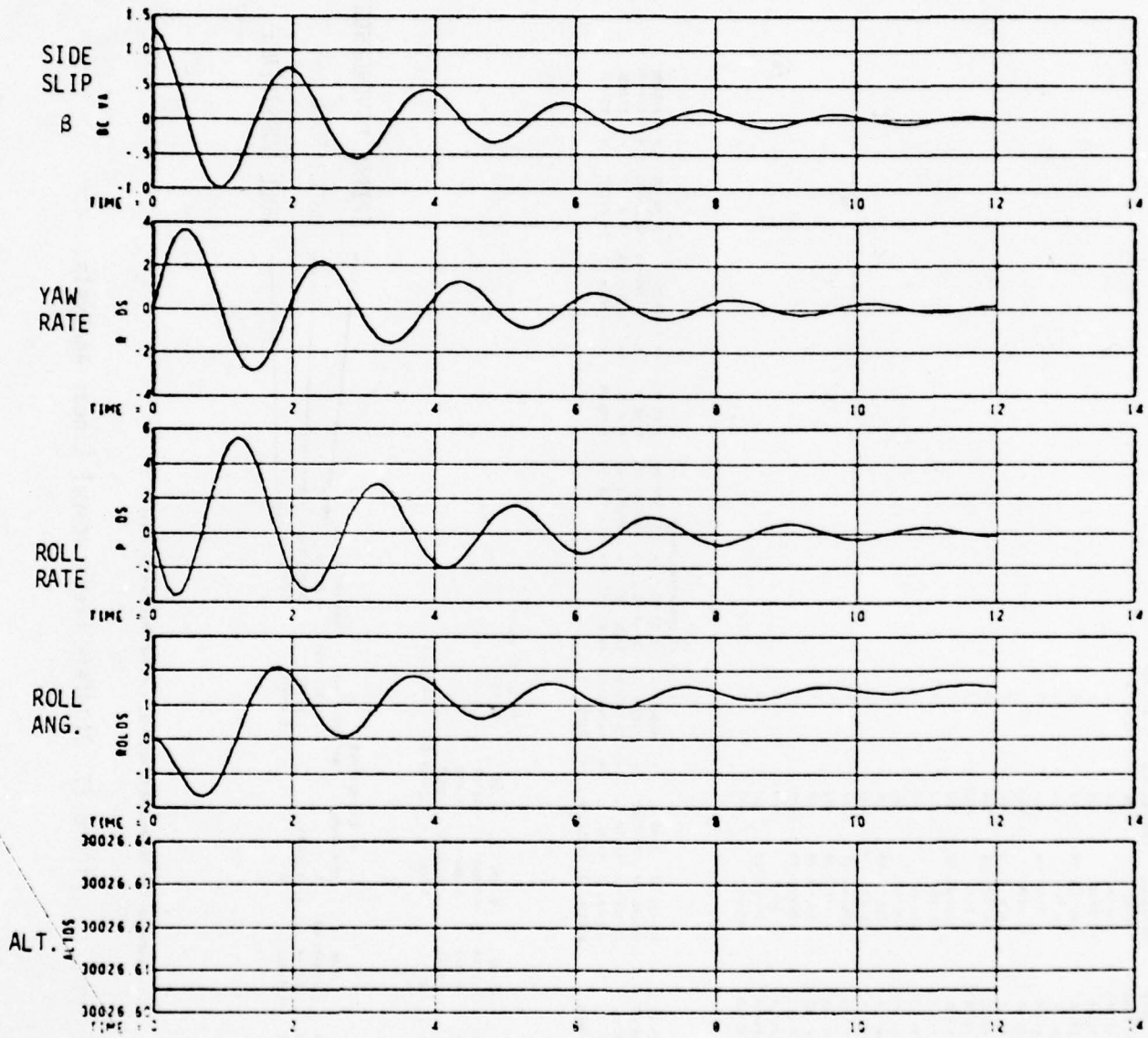

Figure 28 Jindivik Free Lateral Time History Plots

Referring back to Figure 10, we now ask for a LINEAR ANALYSIS and a SIMULATION of the free airplane with all longitudinal and lateral states (except yaw) active. The results of the LINEAR ANALYSIS are shown in Figure 29. Note that the 9 eigenvalues match the 5 eigenvalues of the Figure 22 plus the 4 eigenvalues of Figure 27 as expected. Similarly the time history plots of the SIMULATION for this case, Figures 30 and 31 respectively match those of Figures 24 and 28. The altitude divergence mode indicated in Figure 31 was also present in the free longitudinal analysis but was not plotted in Figure 24.

The next command was for a TRANSFER FUNCTION analysis of the pitch moment vs pitch angle and Figure 32 shows the printout of this analysis. Figure 33 shows the corresponding off line BODE plots of Figure 32 results. Note that the phugoid and the short period modes of oscillations can be detected in Figure 33 (also see Figure 22). Figures 34 and 35 respectively show the corresponding NICHOLS and NYQUIST plots of the same transfer function analysis.

Finally, when no more analysis commands are to be executed, the EASY program will print the current parameter values, see Figure 36. Note that all but one (P2 ES) default values of .99999 have been replaced with the default values coded within the various components e.g. OL,DL,VA etc. The parameter P2 ES is the ambient pressure used in the calculation of engine fan and bleed air properties when requested; in this case we didn't bleed the engine and so the warning can be ignored.

## 5.2 Trim Calculations

Aircraft trim conditions are normally determined by either a pilot or autopilot. In either case, the aircraft must be flown to the desired flight condition and the control surfaces and power setting determined that maintains this condition. Since neither a pilot nor autopilot will be available to control most aircraft modeled by the EASY program, an alternative method is needed to determine trim conditions. The optimal controller design feature of the EASY program was felt to provide a simple solution to this problem. An optimal controller can be specified which stabilizes the aircraft and attempts to drive it to a commanded flight condition. This approach has been shown to

STATE NAME	OPERATING POINT	PERTURBATION SIZE	INTEGRATOR CONTROL	REAL	IMAGINARY	NATURAL FREQ.	DAMPING RATIO
1 X1 OC	208.20	.100	0	.367784E-01	0.	.367784E-01	-1.00000
2 X2 OC	-4.5936	.100	0	.748929E-07	0.	.748929E-07	-1.00000
3 X3 OC	-.48557E-04	.100	0	-.820159E-01	0.	-.820159E-01	.113350
4 X4 OC	-16.742	.100	0	-.814874E-01	0.	-.814874E-01	.888187E-01
5 X5 OC	-17174E-04	.100	0	-.287163	0.	-.287163	.224354
6 X6 OC	-5.6826	.100	0	-.803254	0.	-.803254	1.00000
7 X7 OC	-.40810E-04	.100	0	-1.43358	0.	-1.43358	1.00000
8 X8 OC	-.48695E-06	.100	0				
9 X9 OC	-2.5132	.100	0				
10 X10 OC	1.8015E-03	.100	0				
11 X11 ES	26.497	.100	0				
12 X12 ES	583.48	.100	0				
13 U DS	720.41	.100	1				
14 V DS	16.308	.100	1				
15 W DS	-16.430	.100	1				
16 P DS	-.70241E-21	.100	1				
17 U DS	-.45348E-18	.100	1				
18 M DS	-.51841E-23	.100	1				
19 M DS	-.29955E-18	.100	1				
20 P11 DS	-1.3062	.100	1				
21 P12 DS	-.16562E-03	.100	0				
22 AL1 DS	30027.	.100	1				

RATES AT OPERATING POINT

1 X1 OC	.14385E-01	2 X2 OC	.12134	3 X3 OC	.2189.8	4 X4 OC	-.48968	8 X8 OC	-.21.813
6 X6 OC	.12804E-01	7 X7 OC	-.8.1381	8 X9 OC	-.80078	9 X9 OC	-.81400E-01	10 X10 OC	-.80258
11 X11 ES	-.28071E-02	12 X12 ES	-.30380E-11	13 U DS	-.39418E-02	14 V DS	-.3.8447	18 W DS	-.11117E-
16 P DS	-.22.345	17 O DS	.7242E-02	18 R DS	.14.183	19 R10 DS	.70920E-21	20 P12 DS	-.48343E-
21 P12 DS	.93865E-23	22 AL2 DS	.31195E-02						

4 ELEMENTS OF /RATIO/ DIFFER FROM 1 BY 10%. THESE ELEMENTS ARE PRECEDED BY AN \* IN THE STABILITY MATRIX

RATIO 3, 7) = .500000  
 RATIO 6, 4) = .500000  
 RATIO 5, 8) = .500000  
 RATIO 8, 7) = .811583

STABILITY MATRIX									
U DS	V DS	W DS	P DS	O DS	R DS	RODS	P11 DS	P12 DS	AL2 DS
1 DS	-.2133E-01	-.4840E-03	.4849E-03	0.	.2888	.2846	0.	-.8814	.2718E-02
2 DS	-.4814E-02	-.2178	.1117E-03	-.2878	0.	-.12.87	.8814	0.	.1252E-03
3 DS	-.1283	-.2025E-02	-1.708	-.2845	12.87	0.	-.4899E-03	.1231E-01	-.1138E-02
4 DS	-.3951E-01	-1.372	-1.382	0.	1.721	0.	0.	0.	.7892E-03
5 DS	-.7271E-02	-.4382E-03	-1.182	-.1527E-03	-.2644E-01	-.1827E-03	0.	0.	-.2447E-03
6 DS	-.1985E-01	.8707	-.1244E-02	-.9993E-01	-.3801	0.	0.	0.	-.8008E-02
7 DS	0.	0.	1.000	-.1194E-21	-.1808E-21	-.1808E-21	0.	0.	0.
8 DS	0.	0.	0.	1.000	-.5235E-20	-.7070E-23	0.	0.	0.
9 DS	0.	0.	0.	0.	0.	-.2847	12.88	0.	0.
10 DS	-.2786E-01	0.	-.8987	0.	0.	0.	0.	0.	0.

Figure 29 Jindivik Free Longj-Lat Linear Analysis

FREE LONGI-LATERAL MODEL STABILITY AXIS DATA

77/08/23. 15.21.48.

SIMULATION DISPLAY 2

CASE NO. 10

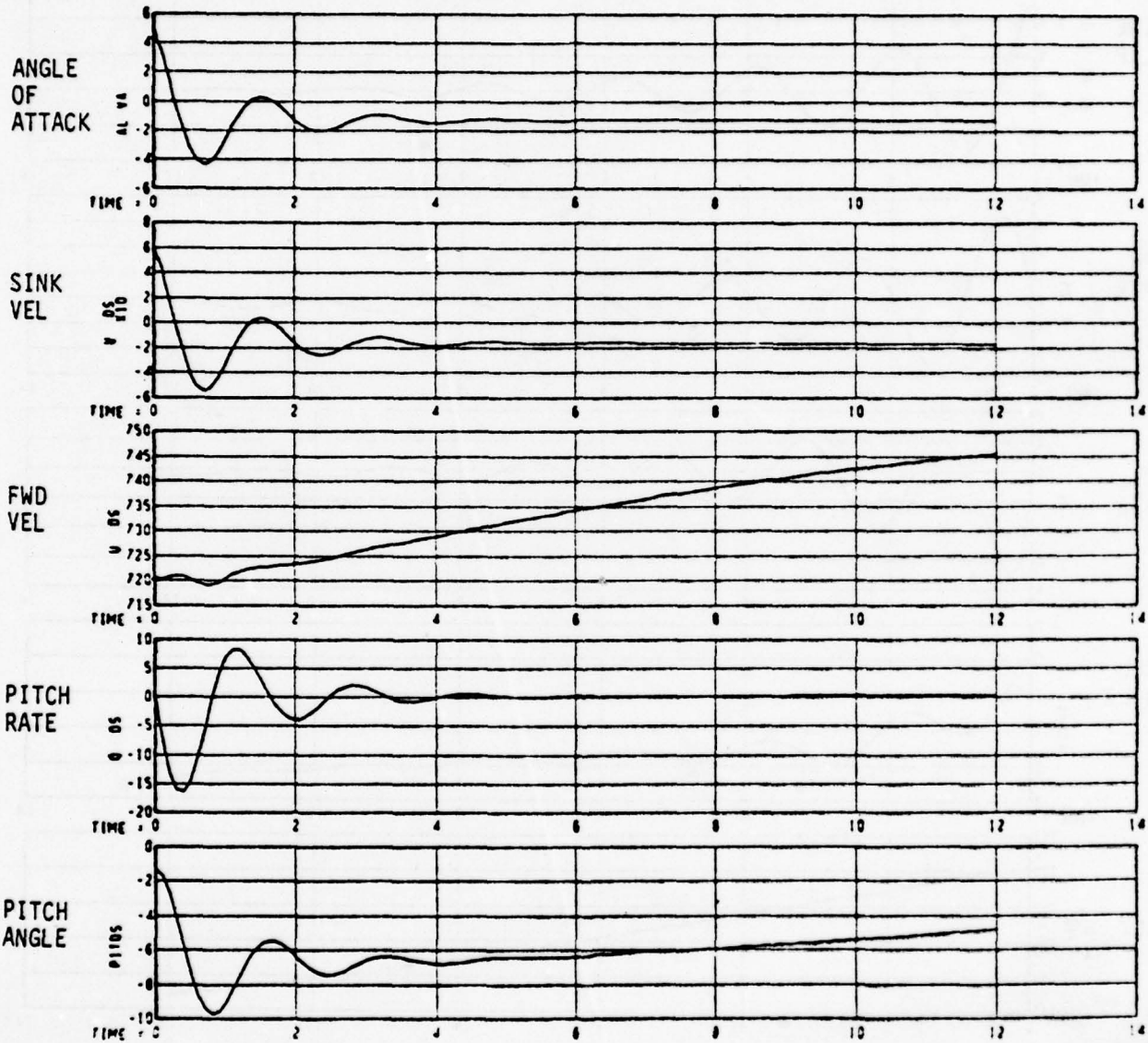

TIME ~ SECS

Figure 30 Jindivik Free Longi-Lat Time History Plots

FREE LONGI-LATERAL MODEL STABILITY AXIS DATA

77/08/23. 15.21.48.

SIMULATION DISPLAY 1

CASE NO. 10

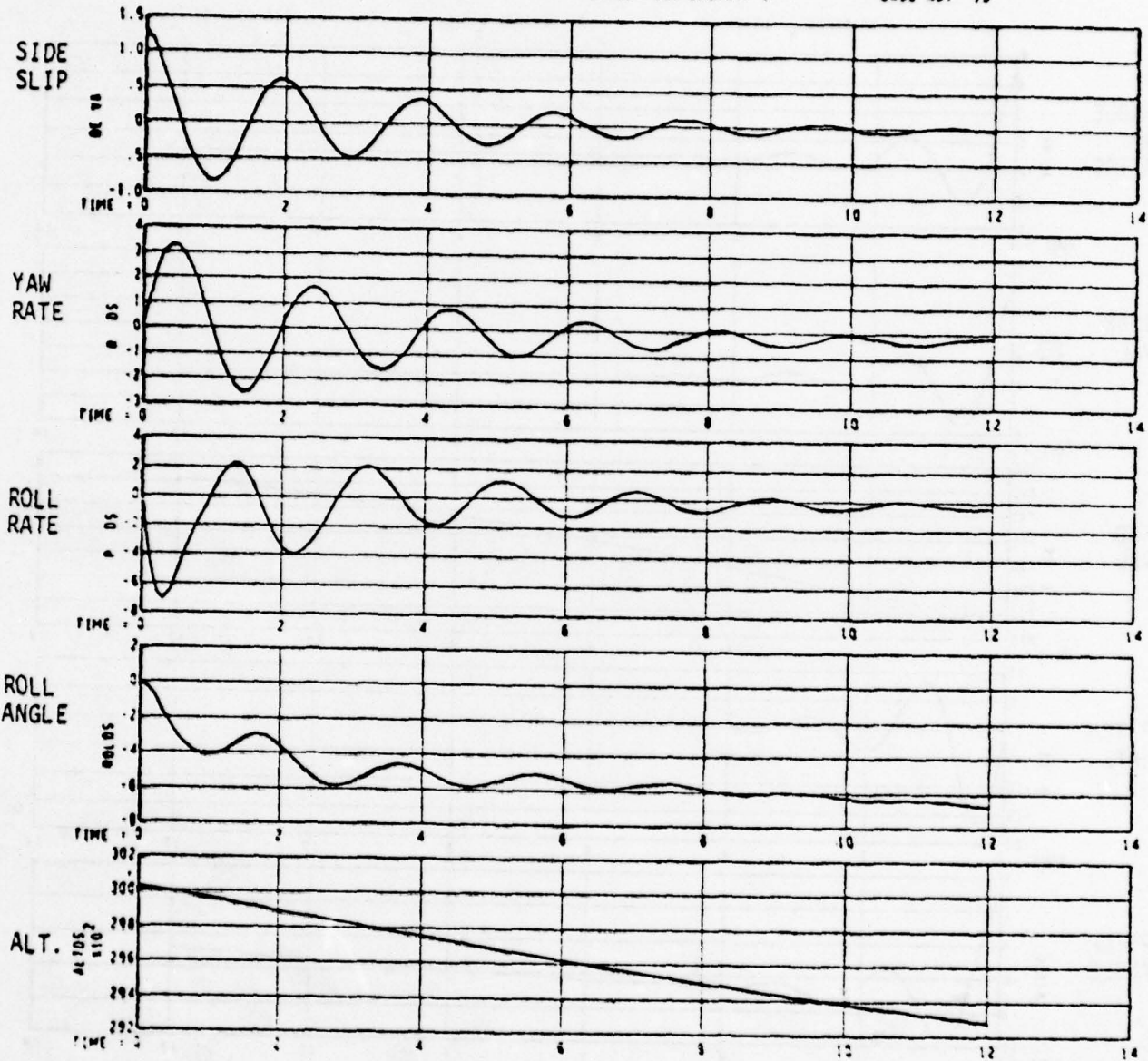

TIME ~ SECS

Figure 31 Jindivik Free Longi-Lat Time History Plots



LONGITUDINAL TORQUE TRANSFER FUNCTION

70/03/23. 18.54.31.

BODE MAGNITUDE PLOT

CASE NO. 12

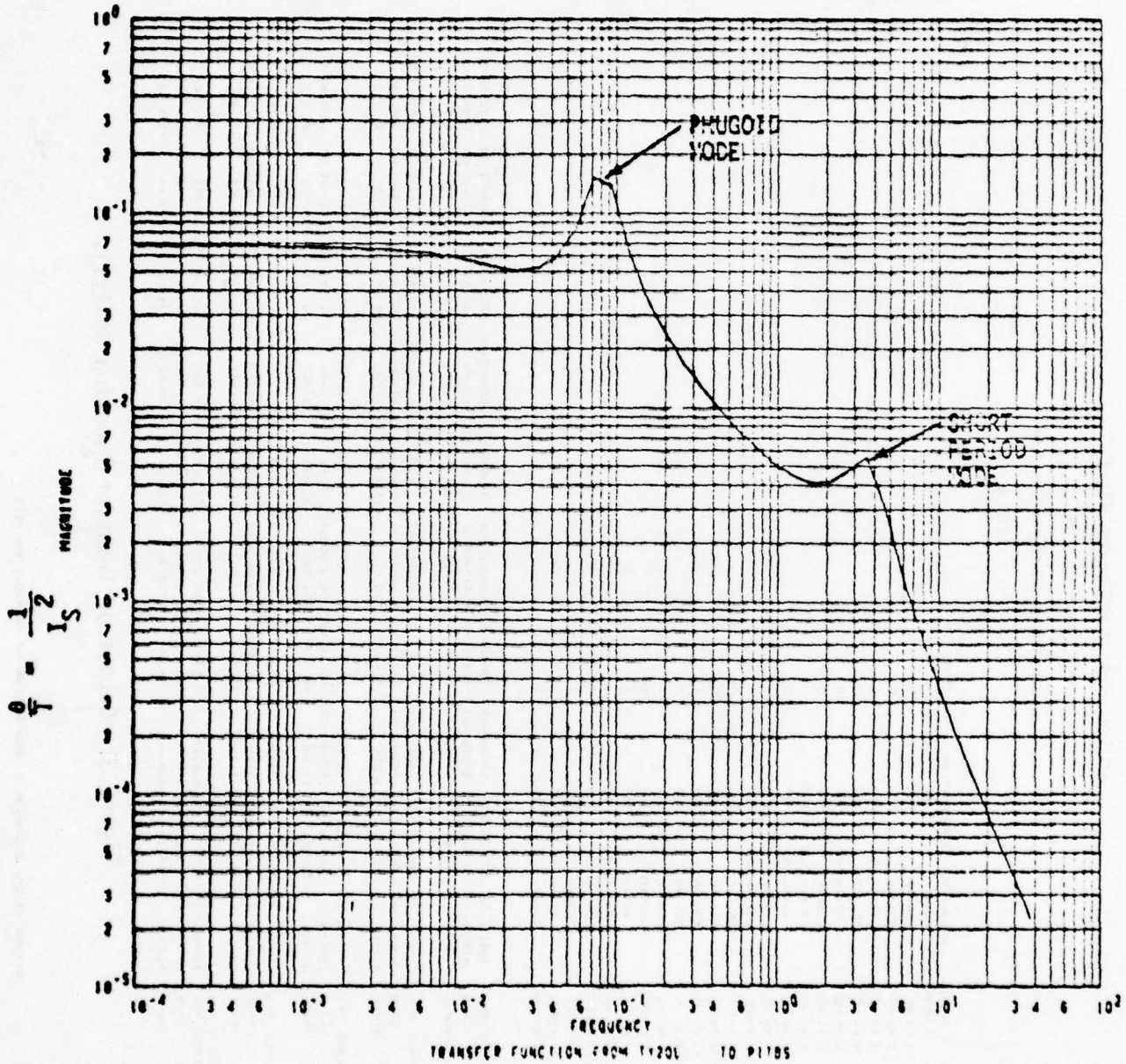

Figure 33 Transfer Function Output "BODE" Plot

LONGITUDINAL TORQUE TRANSFER FUNCTION

78/03/23. 18.54.31.

BODE PHASE PLOT

CASE NO. 12

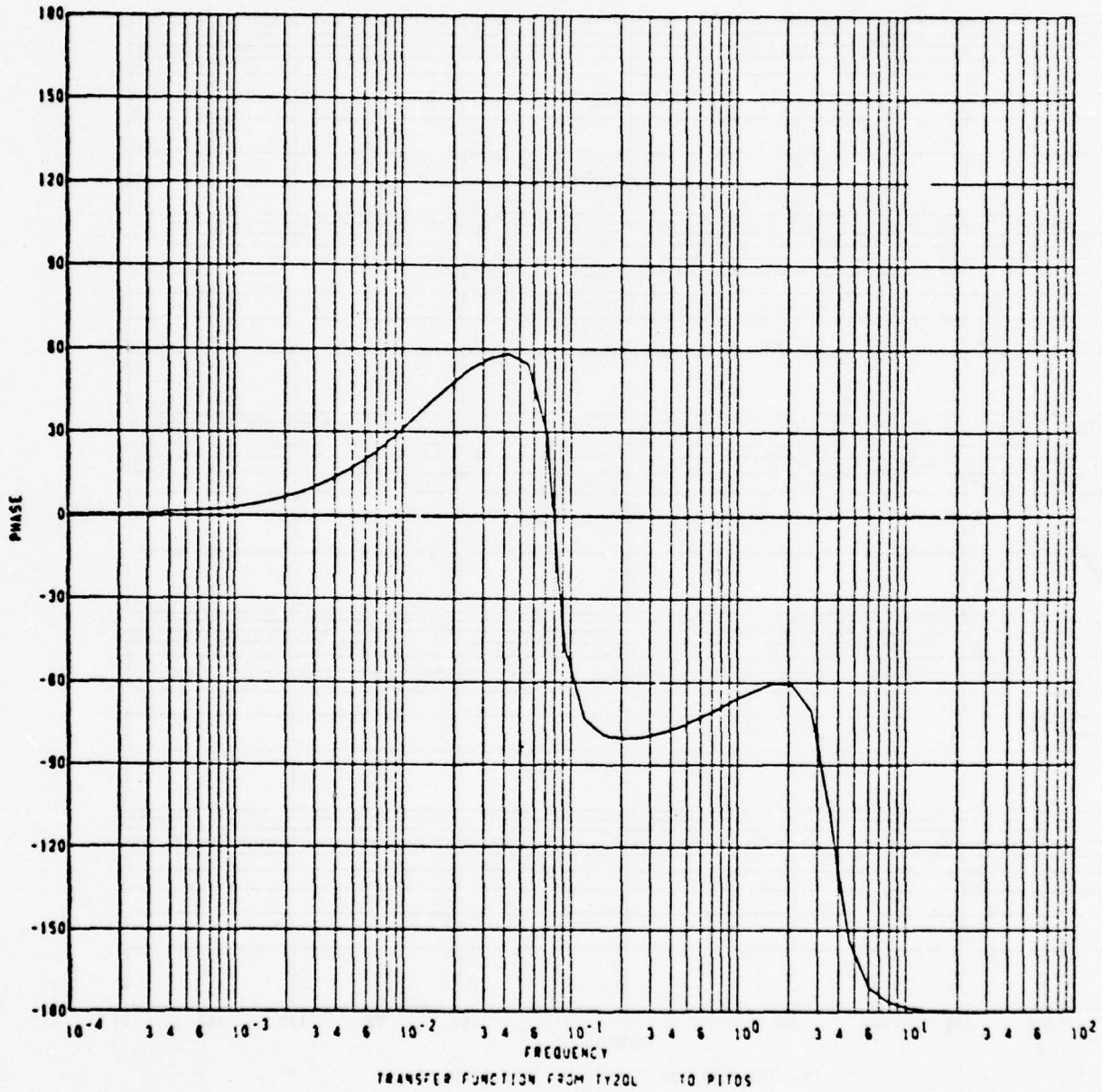

Figure 33 Transfer Function Output "BODE" Plot (Concluded)

LONGITUDINAL TORQUE TRANSFER FUNCTION

70/03/23 16.54.32

NICHOLS PLOT

CASE NO. 13

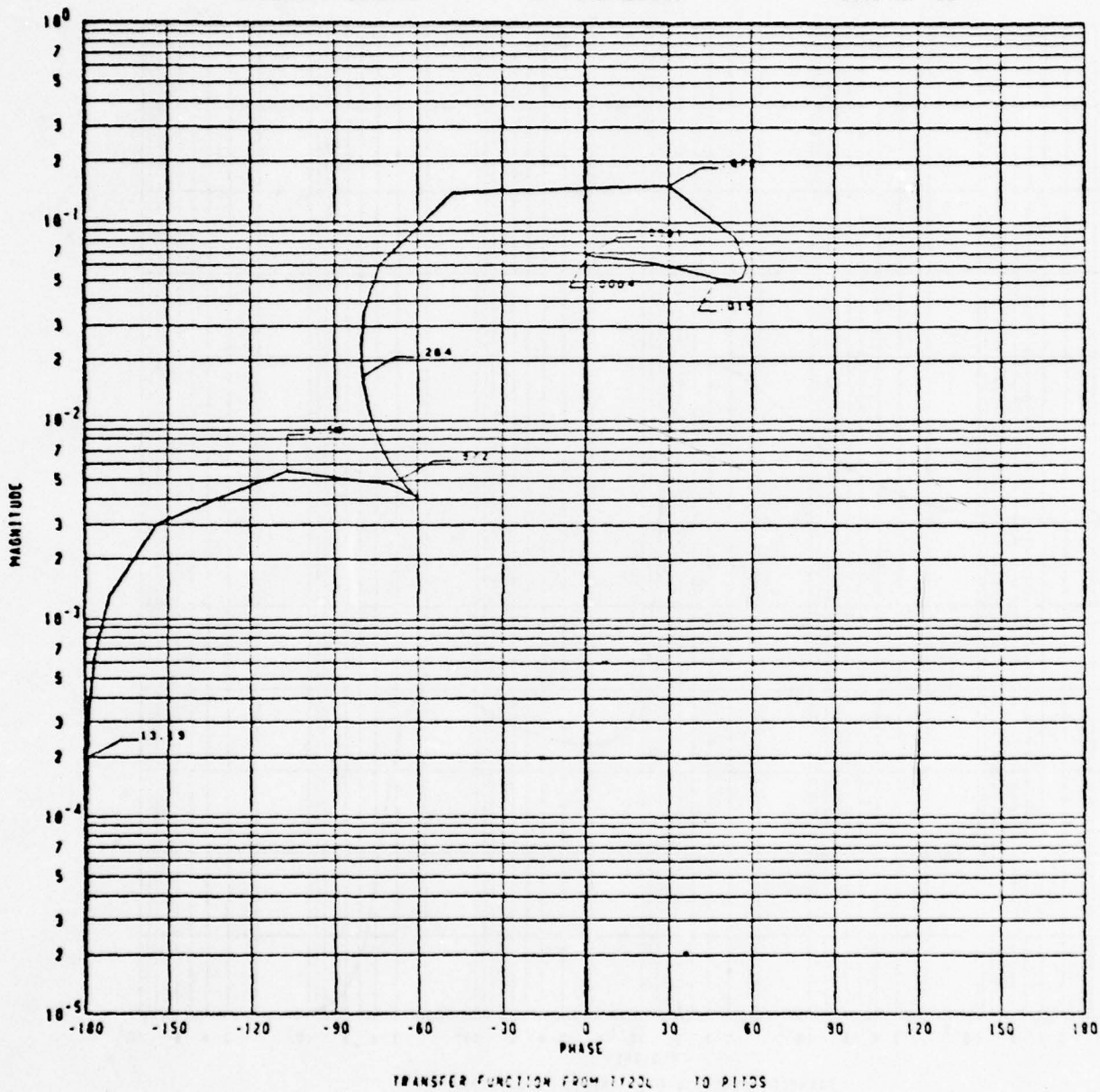

Figure 34 Transfer Function Output "NICHOLS" Plot

LONGITUDINAL TORQUE TRANSFER FUNCTION

78/03/23. 18.54.32.

NYQUIST PLOT

CASE NO. 14

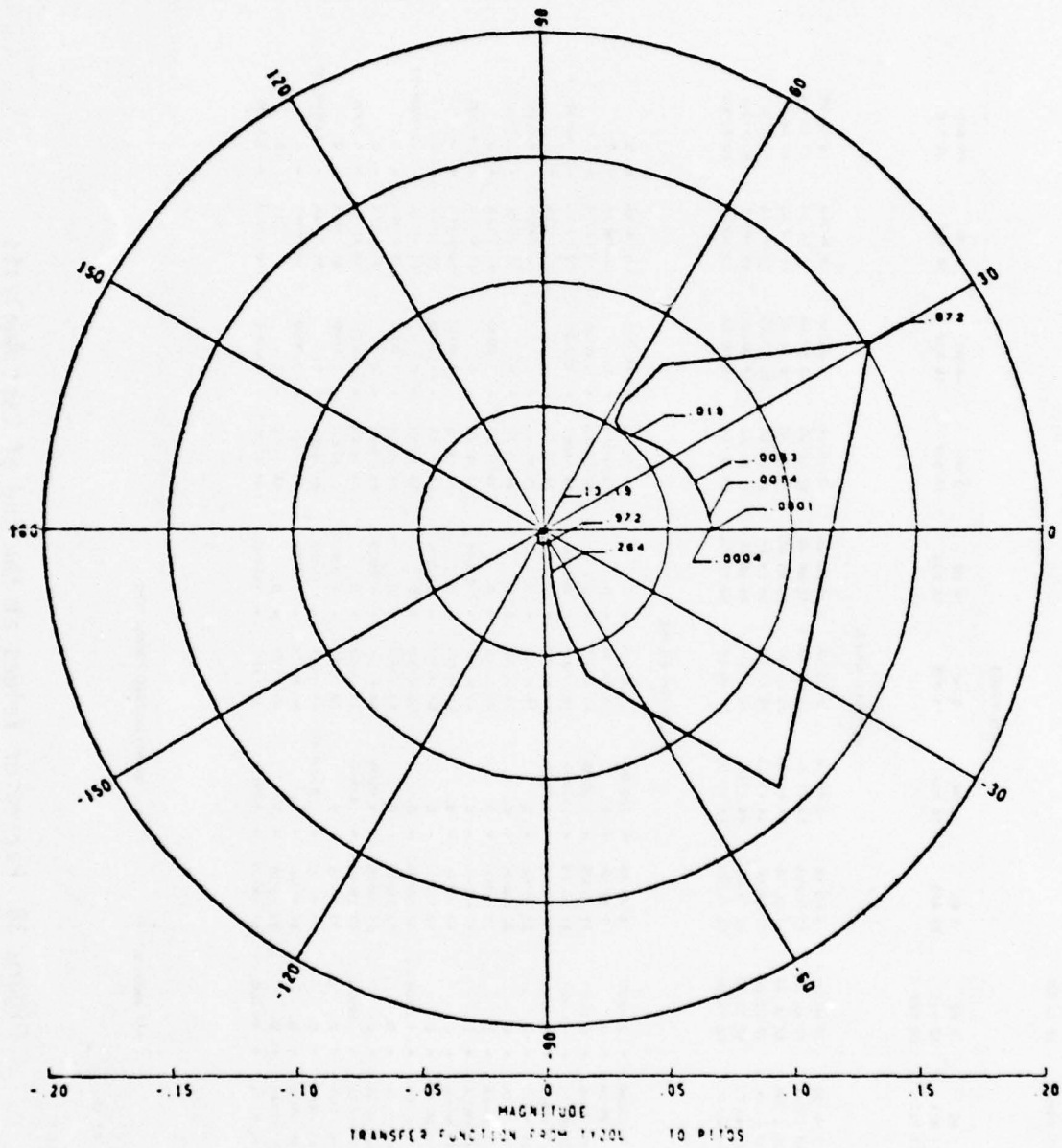

Figure 35 Transfer Function Output "NYQUIST" Plot

STATE NAMES

1 X1 OC 2 X2 OC 3 X3 OC 4 X4 OC 5 X5 OC 6 X6 OC 7 X7 OC 8 X8 OC 9 X9 OC 10 X10OC  
 11 X11OC 12 X12 OC 13 U DS 14 V DS 15 W DS 16 P DS 17 O DS 18 R DS 19 MOLOS 20 PITDS  
 21 YAMUS 22 ALTDS

RATE NAMES

1 R1 2 R2 3 R3 4 R4 5 R5 6 R6 7 R7 8 R8 9 R9 10 R10  
 11 R11 12 R12 13 R13 14 R14 15 R15 16 R16 17 R17 18 R18 19 R19 20 R20  
 21 R21 22 R22

VARIABLE NAMES

1 UO VA 2 VQ VA 3 WQ VA 4 PQ VA 5 QO VA 6 RO VA 7 IOVA 8 OMTVA 9 IMTVA 10 CALVA  
 11 SALVA 12 AL VA 13 ALPVA 14 VT VA 15 BE VA 16 WP VA 17 UP VA 18 EU VA 19 EV VA 20 EF VA  
 21 SIOVA 22 OL VA 23 OS VA 24 MACVA 25 ZO AC 26 XO AC 27 MO AC 28 YB AC 29 LB AC 30 NB AC  
 31 OY OC 32 OZ OC 33 OJ OC 34 FX ES 35 FZ ES 36 TV ES 37 SPES 38 FSTES 39 PPUES 40 TPUES  
 41 WZ ES 42 T2 ES 43 FKZOL 44 FZ2OL 45 TY2OL 46 UD OL 47 WU OL 48 MAZOL 49 APZOL 50 FYZOL  
 51 VU OL 52 TX2OL 53 TZ2OL 54 XQ DS 55 YQ DS 56 PQ DS 57 CQ DS 58 HQ DS 59 MLLOS 60 PLOOS

PARAMETER VALUES

1 111VA = 3.0000 2 V5 VA = 728.00 3 ALSVA = 0. 4 S VA = 78.000 5 UM VA = 0.  
 6 V6 VA = 0. 7 W6 VA = 0. 8 P6 VA = 0. 9 OMTVA = 0. 10 IMTVA = 0.  
 11 116VA = 6.0000 12 TLQES = 1.0000 13 AMRES = 0. 14 GAKES = 1.0000 15 CAZES = 0.  
 16 A6 ES = -10.900 17 ZO ES = -.37500 18 FAMP'S = 14.700 19 TAME S = 489.00 20 P2 ES = .58999  
 21 11MES = 1.0000 22 1BLES = 1.0000 23 FKTES = 0. 24 XA OL = 0. 25 XU OL = 0.  
 26 ALA OL = 0. 27 XTHOL = 0. 28 ASPOL = 0. 29 XUSOL = 0. 30 XRHOL = 1.0000  
 31 ZA OL = 0. 32 ZAHOL = 0. 33 ZO OL = 0. 34 ZU OL = 0. 35 ZOH OL = .25940  
 36 ZTHOL = 0. 37 ZSPOL = 0. 38 ZGHOL = 0. 39 FZHOL = 1.0000 40 ZUOL = 0.  
 41 WAOH = 0. 42 MAJH = 0. 43 MAJ OL = -.24600 44 MJ OL = 0. 45 MHOL = .04200  
 46 WTHA = 0. 47 MPOL = 0. 48 MCOL = 0. 49 MAROL = 1.0000 50 MHPOL = 0.  
 51 MLOL = 0. 52 KCOL = 0. 53 MASOL = 83.920 54 C OL = 4.0000 55 APTOL = 0.  
 56 FMPOL = 3.0000 57 STAPOL = 0. 58 SPOL = 0. 59 YPOL = 0. 60 YF DL = -.21500E-01  
 61 V6 DL = 0. 62 Y6HOL = 0. 63 Y6HOL = 0. 64 YUL = 1.0000 65 YTHOL = 0.  
 66 V1 DL = 0. 67 Y6HOL = 1.0000 68 AYHOL = 1.0000 69 YHOL = 0. 70 LKHOL = 0.  
 71 LP DL = -.37000 72 LH DL = .44980 73 LHOL = 0. 74 LUHOL = -.14184 75 FCLDL = 1.0000  
 76 LTHOL = 0. 77 LF DL = 0. 78 LQEDL = 1.0000 79 KLHOL = 1.0000 80 LHOL = 0.  
 81 PRHOL = 0. 82 MP DL = .18700E-02 83 MH DL = -.15450 84 MLHOL = 0. 85 MHOL = .18700E-01  
 86 FTHOL = 0. 87 MH DL = 0. 88 MLHOL = 1.0000 89 PHOL = 1.0000 90 NHOL = 0.  
 91 FSPOL = 0. 92 FSPOL = 0. 93 FTHOL = 0. 94 FADL = 0. 95 TZL DL = 0.  
 96 B DL = 19.000 97 JAXDS = 1180.0 98 IYVDS = 1811.0 99 1ZLDS = 2840.0 100 1KZDS = -200.00

\*\*\* WARNING \*\*\* UNINITIALIZED PARAMETERS

P7 ES

Figure 36 Parameter Values at the End of Last Analysis

be successful for straight and level flight conditions at specified altitude and Mach numbers. However, attempts to achieve fully coordinated turning trim conditions have not been completely successful. Steady state turns have been achieved but the turns are often over or under coordinated, see Reference [1].

The following sections describe the work that has been done using the optimal controller for trim determination. An optimal controller can be added to the aircraft model to provide Mach, altitude, turn rate, or heading holding. The steady state algorithm of the program can then be used to determine the trim condition. Once the desired trim conditions have been determined, the optimal controller can be omitted from the model on subsequent analyses.

### 5.2.1 Trim Model Description

As described in Section 4.13, an optimal controller model is defined by specifying the quantities sensed by the optimal controller and the quantities actuated by the optimal controller. The sensed (input) quantities must provide adequate information to stabilize and control the aircraft, i.e. satisfy the observability conditions. In addition, the input quantities must allow the desired trim condition to be specified.

Thus, for a constant Mach, constant altitude condition, the total velocity and altitude should be provided as two of the optimal controller inputs. In general, the observability conditions will be met if all position states of the aircraft are provided as inputs.

The optimal controller outputs must have adequate control authority to stabilize and control the aircraft, i.e. satisfy the controllability conditions. The controllability conditions will be met if all the aircraft control surfaces and the thrust level are provided as outputs.

The following example shows the Model Generation commands required to specify an optimal controller for straight and level flight.

### Example 5.1: (F106 Airplane)

```
{ LOCATION = 335 OC
  O.C. INPUTS = ALTDS, VT VA, ROLDS, YAWDS, PITDS
    P DS, Q DS, R DS, V DS, W DS
  O.C. OUTPUTS = ELEOL, THRES, AILDOL, RUDDL
```

The O.C. INPUTS command specifies the inputs to the optimal controller as altitude, ALTDS; total velocity, VT VA; roll, yaw and pitch, and the angular and linear rates P,Q,R, and V and W. For each of these quantities a desired value and penalty for deviation from these values may be specified. Desired values are specified for altitude, total velocity, roll, yaw, P,Q,R, and V while approximate values are provided for pitch and W. Large penalties are assigned to the quantities with known desired values and small penalties to the quantities with approximate values. The O.C. OUTPUTS command allows the optimal controller to drive the elevator, thrust level, ailerons, and rudder of the aircraft.

To obtain trim conditions during other maneuvers, the input quantities would be replaced by others which specified the flight condition.

#### 5.2.2 Optimal Controller Design

The inputs and outputs of the optimal controller are specified to the Model Generation program as described in Section 5.2.1. The actual design of the optimal controller is performed by the Analysis program. Before this design can be performed, the design criteria and the operating point, i.e. desired values or approximate values, of the optimal controller inputs and outputs should be specified. The default design criteria puts equal weight on all O.C. INPUTS. In example 5.1, the control of the first four inputs: altitude, total velocity, roll angle and yaw angle, are much more important than the other six quantities which were added to satisfy observability requirements. We therefore specify this by putting a larger weight in the first four elements of the controller criteria array, Q.

In selecting weights, the units of each quantity must be considered. The following table shows how weights might be selected for a straight and level trim.

	OC INPUT QUANTITY	OPERATING POINT	ALLOWABLE ERROR	WEIGHT
ALTDS	Altitude	20,000 ft.	100	.0001
VT VA	Total Velocity	932 ft/sec	1	1
ROLDS	Roll Angle	0°	0.1	100
YAWDS	Yaw Angle	0°	1	1
PITDS	Pitch Angle	~3°	1	1
P DS	Roll Rate	0°/sec	0.1	100
Q DS	Pitch Rate	0°/sec	0.1	100
R DS	Yaw Rate	0°/sec	0.1	100
V DS	Side Slip	0 ft/sec	0.1	100
W DS	Sink Rate	~40 ft/sec	10.	.01

Weights were chosen to be the reciprocal of the allowable error squared.

The optimal controller design is based on operation about a specified operating point. This poses a problem, since in the trim application we are attempting to determine the operating point of the aircraft. Fortunately the operating point provided to the optimal controller need only be an approximation. Differences between the initial guess and the final value are made up by small errors in the requested flight condition. These errors can be reduced by taking the results of one trim analysis as the starting point of another analysis.

An operating point should be specified for all optimal controller inputs and outputs. Since zero is provided as a default for all operating point values, only those quantities that are expected to have non-zero values need be considered. Typical operating point values are shown for example 5.1 in the previous table.

Of the four output quantities only the thrust setting, THRES, would have a significant non-zero value. An initial guess as to the thrust required should therefore be provided.

The following example shows the Analysis program commands required to specify the design criteria and operating point for the turn example 5.1.

Example 5.2: (F106 Airplane)

```
O.C. DATA
Q = .0001, 1, 100, 1, 1, 100 100, 100, 100, .01
YOP = 20000, 932, 0, 0, 3, 0, 0, 0, 0, 40
UOP = 0, 5700, 0, 0
DESIGN O.C.
```

The line beginning "Q =" specifies the weights for errors in the input quantities to the optimal controller. The line beginning "YOP =" specified operating point values for these quantities. The "UOP =" line specifies a guess of 5700 pounds for the second output quantity, thrust. The DESIGN O.C. command initiates the optimal controller design process.

### 5.2.3 Steady State Solution

The steady state algorithm of the Analysis program attempts to find the value of  $x$  in the state equation,  $\dot{x} = f(x)$ , that drives  $\dot{x}$  to zero. If any states do not take on a constant value in the steady state being sought they should be "frozen" as discussed in Section 4.2. In a turn maneuver, all states but the yaw angle achieve a constant value. It is therefore necessary to eliminate the yaw angle from the model by freezing it before requesting the steady state solution. Note, this must be done after the optimal design has been completed since the optimal design program does not allow the order of the model to be reduced once it is specified by the Model Generation program.

Before requesting a steady state solution, it is recommended that any saturation effects or other severe nonlinearities in the actuation paths of the optimal controller be temporarily removed. This may be necessary due to

the high gains that can occur in the optimal controller and the linear approximations made during the steady state analysis. Recall that the optimal controller is being designed to merely stabilize the aircraft and provide small steady state errors. No attempt is made to obtain desirable dynamic response or reasonable gain levels. By temporarily removing nonlinearities, these problems can be bypassed. An alternative would be to seek the steady state via the SIMULATION rather than STEADY STATE analysis. If the nonlinearities such as flap limits are implemented with the SA saturation component, it is a simple matter to set the saturation limits to large values before requesting the STEADY STATE analysis and then restore them after the trim condition is achieved.

The following example demonstrates the points made in this section.

Example 5.3:

INT CONTROL = YAWDS = 0	Freeze Yaw Angle
PARAMETER VALUES =	
C3 SA E = 1.E36, C6 SA E = -1.E36	Remove elevator (saturation)
(Part of F106 elevator control system) limits	
STEADY STATE	Request steady state
XIC-X	Transfer steady state solution to XIC vector
PARAMETER VALUES =	
C3 SA E = 8, C3 SA E = -25.	Restore elevator limits

The following table summarizes the results of this turning trim determination:

	OC INPUT QUANTITIES	OC WEIGHT Q	DESIRED VALUE	TRIM VALUE ATTAINED
ALTD5	Altitude	.1	20000	19992.
MACVA	Mach No.	10000	.9	.914
PITDS	Pitch Angle	.01	~3.2	2.96
YAWDS	Yaw Angle	.01	0.	0.
ROLD5	Roll Angle	100	26.5	26.48
Q DS	Pitch Rate	1000	0.4428	0.4372
R DS	Yaw Rate	1000	0.8850	0.8775

Further adjustment of the weights could bring the trim condition closer to the desired values. Once a satisfactory set of weights were obtained they would probably be valid for a wide range of trim conditions. The substitution of total velocity,  $VT VA$ , for Mach number would provide for better speed control.

## SECTION VI

### MISCELLANEOUS

This section describes certain aspects of the EASY program that were not included in previous sections and/or not explained in sufficient details.

#### 6.1 Program Limitations

Certain limitations are placed on the size, and complexity of models that can be generated by the Model Generation program. These limitations are due to various array dimensions within the program and can be easily relaxed by enlarging these array dimensions. The current limitations are shown in Table 4. A tabulation of the various limitations and the array causing each is given in the EASY program source listing.

TABLE 4  
EASY MODEL GENERATION PROGRAM LIMITATIONS

Standard Component Limitations:	
Maximum number of standard components	150
Maximum number of inputs for any standard component	63
Maximum number of outputs for any standard component	63
Maximum number of tables for any standard component	15
System Model Limitations:	
Maximum number of components per model	100
Maximum number of tables per model	50
Optimal Controller Limitations:	
Maximum number of optimal controller inputs	10
Maximum number of optimal controller outputs	10
Maximum number of optimal controller criteria variables	10

## 6.2 FORTRAN Statements

The FORTRAN STATEMENTS command phrase allows the system analyst to supplement the standard EASY components with Fortran statements. Using this feature, the analyst can introduce his own component subroutines, program logic, DO loops, etc., as necessary to model any system feature not obtainable with standard EASY components.

In order to assure that all of the information required by a specific component is available at the time that component behavior is calculated, the components in a system model must be specified in the proper sequence (to give an explicit model). If a model is not described in such a proper sequence, the EASY Model Generation Program will attempt to reorder the component sequence to achieve an explicit model. This capability of automatic reordering is lost if FORTRAN statements are incorporated into the system model. In order to alert the user, the warning message described in 2.4-13 is printed regardless of whether the model is explicit or implicit.

The FORTRAN STATEMENTS command would normally be used only when some portion of the system cannot be modeled with standard EASY components. When using this feature of the program, the analyst must perform many of the detail connections and naming of variables that are normally accomplished by the EASY program. In return for these added tasks, the analyst gains a great deal of additional freedom and flexibility in forming details of his system model.

A model for analysis by the EASY program may not consist of Fortran statements alone, but must be used in conjunction with at least one standard EASY component. Signal connections between standard components and any new component modeled by Fortran subroutines are not necessary. The standard component used is arbitrary as long as it contains at least one state and one variable. The addition of user supplied Fortran subroutines to the FORTRAN STATEMENTS part of the EASY Model requires additional control cards as illustrated in Section 4.7.2, Reference (2).

If the Fortran statements furnished by the analyst require tables or state variables (integration), or have variables or parameters that the analyst wishes to access during an analysis, the ADD command statements must be used to include these quantities in the model.

### 6.3 Deck Set-Up

#### Model Generation and Analysis

The Model Generation and Analysis programs can be executed on the same computer run via the deck arrangement shown in Figure 37. In order to prepare the data statements for the Analysis program, the analyst must anticipate the parameter, state and variable names that will be generated by the Model Generation program. Due to the systematic way these names are generated from the model component name, this is usually no problem.

The set of control cards shown in Figure 37 is for a SCOPE 3.4 operating system "A", at WPAFB 6600 computer facilities.

### 6.4 Tabular Data Example

This aspect of data input was discussed in Section 4.1 earlier. However, an additional example is included here to clarify the steps required to implement graphical raw data into a two dimensional (two independent and one dependent variables) tabular input data and the resulting plot obtained from the EASY program.

Figure 38 shows the performance map of an ACLS turbofan where the total corrected mass flow (lbm/sec), the dependent variable, is shown as a function of corrected back pressure (psfg), the primary independent variable, for various drive pressures (psia), the secondary independent variable. The dashed lines of the map represent extrapolated regions of performance necessary to fill the tabular matrix. This graphical data was transcribed and input as a table named TOTFT, with 16 points for the primary independent variable (300 to 10 psfg) and 9 points for the secondary independent variable (15 to 25.7 psia) plus the 16 x 9 matrix of the dependent variable, see Figure

CONTROL CARD STREAM FOR BATCH MODEL

GENERATION AND ANALYSIS JOB EXECUTION

DLF,T100,I0100,CM135000,STCSA. E760273,FISCHER,255-3011

ATTACH(EASY4,EASY,CY=1,MR=1)

ATTACH(TAPE78,EASY,CY=5,MR=1)

ATTACH(ULIB,EASY,CY=4,MR=1)

COPYBR(INPUT,TAPES)

REWIND(TAPES)

COPYSBF(TAPES,OUTPUT)

REWIND(TAPES)

LIBRARY(ULIB)

EASY4(TAPES)

RETURN(EASY4,TAPE78)

REWIND(TAPE9,PR0G,TAPE5)

FTN(I=TAPE9,B=MODEL,L=0)

ATTACH(N0NSIM4,EASY,CY=2,MR=1)

COPYBR(INPUT,TAPES)

REWIND(TAPES)

COPYSBF(TAPES,OUTPUT)

REWIND(TAPES)

REWIND(M0DEL)

COPYL(N0NSIM4,MODEL,PR0G)

REWIND(PROG)

PROG,TAPES

EXIT(U)

REWIND(TAPE30)

ATTACH(NSMPPT,EASYDAT,CY=2,MR=1)

NSMPPT.

EXIT(U)

REWIND,DUMMY.

COPY,DUMMY.

EXIT.

EOR

MODEL GENERATION  
COMMAND CARDS

EOR

ANALYSIS PROGRAM  
DATA CARDS

EOF

MODEL  
GENERATION

MODEL  
ANALYSIS

ON-LINE  
PLOTING

Figure 37 SCOPE 3.4 Operating System Deck Set Up Model  
Generation and Analysis

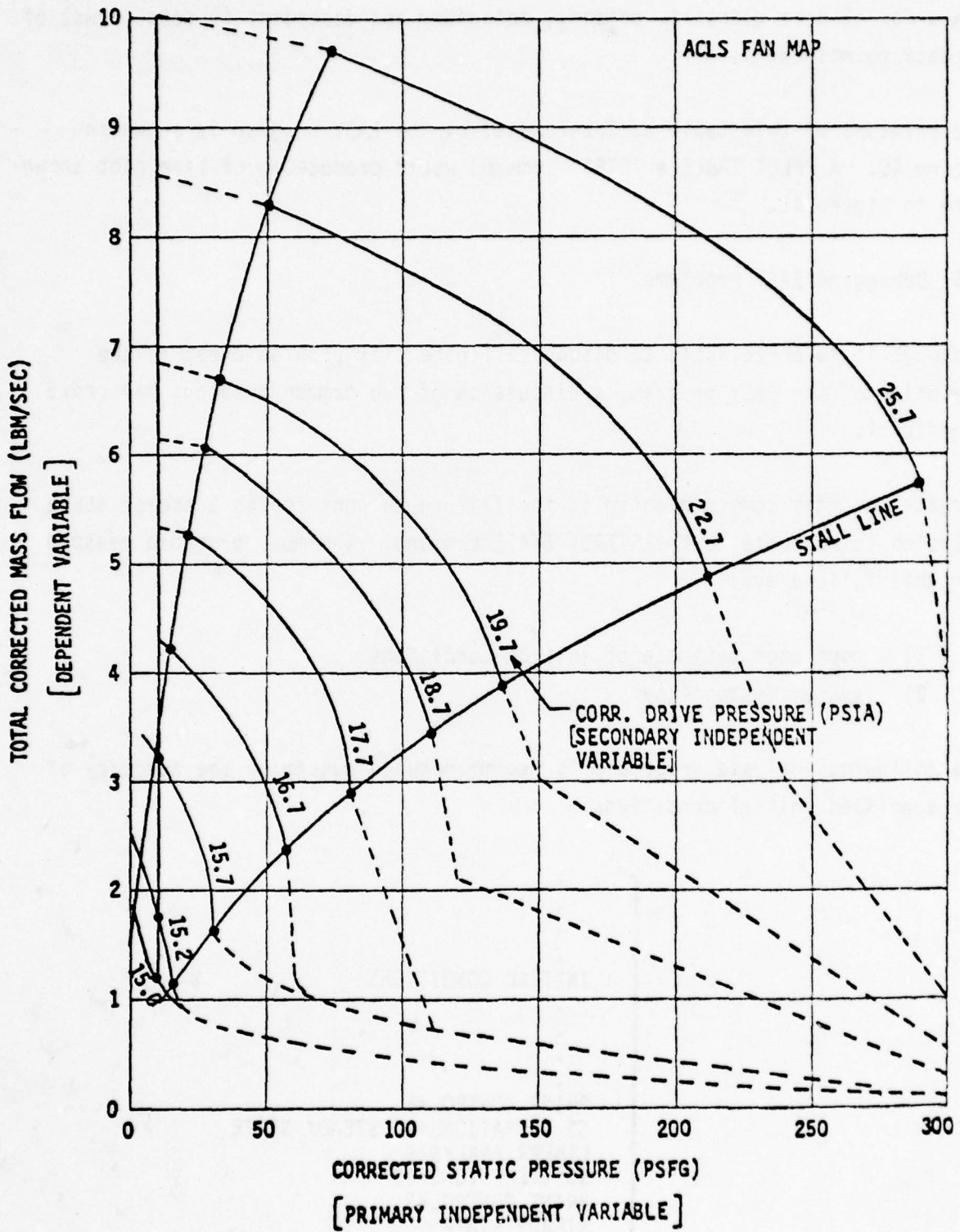

Figure 38 ACLS Fan Performance Map

39. Note that the order of dimensions is secondary followed by primary while the order of data points is primary, secondary and dependent (9 sets (rows) of 16 data points each).

The printout of this table as interpreted by the EASY program is shown in Figure 40. A "PLOT TABLE = TOTFT" command would produce an offline plot shown here in Figure 41.

## 6.5 Debugging EASY Problems

Although it is unrealistic to discuss all potential problem areas in the execution of the EASY program, a discussion of two common problems may prove beneficial.

Perhaps the most common problem is the failure to converge to a steady state solution in response to the STEADY STATE command. The most probable reasons for this failure are:

- 1) poor user estimate of initial conditions
- 2) system instability

The following analysis procedure is recommended to determine the adequacy of the specified initial conditions:

```

{
  .
  .
  .
  INITIAL CONDITIONS
  .
  .
  .
  PRINT CONTROL=6
  SS ITERATIONS=1, STEADY STATE
  LINEAR ANALYSIS
  SS ITERATIONS=30
  PRINT CONTROL=3
  STEADY STATE

```

TABLE, TOTFT      ,16      ,9  
 15, 15.2, 15.7, 16.7, 17.7, 18.7, 19.7, 22.7, 25.7  
 300, 270, 240, 210, 180, 150, 120, 110, 80, 70  
 60, 50, 40, 30, 20, 10  
 .1, .15, .2, .25, .3, .35, .4, .45, .5, .55  
 .6, .65, .7, .75, .8, 1.2  
 .1, .15, .2, .25, .3, .35, .4, .45, .5, .55  
 .6, .65, .7, .8, .9, 1.76  
 .1, .2, .3, .4, .5, .6, .7, .8, .9, 1.0  
 1.1, 1.2, 1.3, 1.98, 2.76, 3.19  
 .1, .2, .3, .4, .5, .6, .7, .8, .9, 1.0  
 1.1, 2.64, 3.32, 3.74, 4.09, 4.29  
 .1, .2, .3, .4, .5, .7, .8, 3, 3.9  
 4.3, 4.62, 4.88, 5.12, 5.3, 5.34  
 .3, .6, .9, 1.2, 1.5, 1.8, 2.1, 3.5, 4.93, 5.2  
 5.43, 5.66, 5.85, 6.04, 6.08, 6.12  
 .5, 1, 1.5, 2, 2.5, 3, 4.9, 5.2, 5.9, 6.1  
 6.28, 6.45, 6.63, 6.69, 6.77, 6.85  
 1, 2, 3, 4.88, 6.25, 6.91, 7.4, 7.55, 7.95, 8.07  
 8.2, 8.3, 8.34, 8.4, 8.48, 8.56  
 4, 6.63, 7.4, 7.95, 8.4, 8.8, 9.17, 9.3, 9.63, 9.75  
 9.77, 9.81, 9.85, 9.91, 9.99, 10.04

Figure 39 Data Input Format Example for a Two Dimensional Table, ACLS Fan Map

TABLE TOTFF

SECONDARY\_INDEPENDENT\_VARIABLE\_TABLE

	15.00	15.20	15.80	16.60	17.70	18.70	19.70	22.70	25.70
300.0	270.0	240.0	210.0	180.0	150.0	120.0	110.0	80.00	70.00
60.00	50.00	40.00	30.00	20.00	10.00				

PRIMARY\_INDEPENDENT\_VARIABLE\_TABLE

	15.00	15.20	15.80	16.60	17.70	18.70	19.70	22.70	25.70
300.0	270.0	240.0	210.0	180.0	150.0	120.0	110.0	80.00	70.00
60.00	50.00	40.00	30.00	20.00	10.00				

DEPENDENT\_VARIABLE\_TABLE

-1000	-1500	-2000	-2500	-3000	-3500	-4000	-4500	-5000	-5500
-6500	-7000	-7500	-8000	-8500	-9000	-9500	-10000	-10500	-11000
-1000	-1500	-2000	-2500	-3000	-3500	-4000	-4500	-5000	-5500
-6000	-6500	-7000	-7500	-8000	-8500	-9000	-9500	-10000	-10500
-15000	-15000	-15000	-15000	-15000	-15000	-15000	-15000	-15000	-15000
1.100	1.200	1.300	1.400	1.500	1.600	1.700	1.800	1.900	2.000
-1000	-2000	-3000	-4000	-5000	-6000	-7000	-8000	-9000	-10000
1.100	2.640	3.320	3.740	4.090	4.290	4.400	4.500	4.600	4.700
4.300	4.820	4.880	4.900	4.900	4.900	4.900	4.900	4.900	4.900
-30000	-60000	-90000	-120000	-150000	-180000	-210000	-240000	-270000	-300000
5.430	5.660	5.850	6.040	6.200	6.320	6.400	6.450	6.480	6.500
-3000	1.000	1.500	2.000	2.500	3.000	3.500	4.000	4.500	5.000
6.280	6.450	6.630	6.800	6.950	7.080	7.180	7.250	7.300	7.330
1.000	2.000	3.000	4.000	5.000	6.000	7.000	8.000	9.000	10.000
8.200	8.300	8.360	8.400	8.420	8.430	8.440	8.450	8.460	8.470
4.000	6.330	7.400	8.100	8.500	8.700	8.800	8.850	8.880	8.900
9.770	9.810	9.850	9.910	9.990	10.04	10.06	10.07	10.08	10.09

TABLE ABLIK

PRIMARY\_INDEPENDENT\_VARIABLE\_TABLE

3.100	8.000	37.00	1.000	9.330	5.600	55.00	1.000
9.440	6.090	56.90	1.000	7.600	3.100	61.00	1.000

DEPENDENT\_VARIABLE\_TABLE

Figure 40 Table TGTFT As Interpreted by EASY

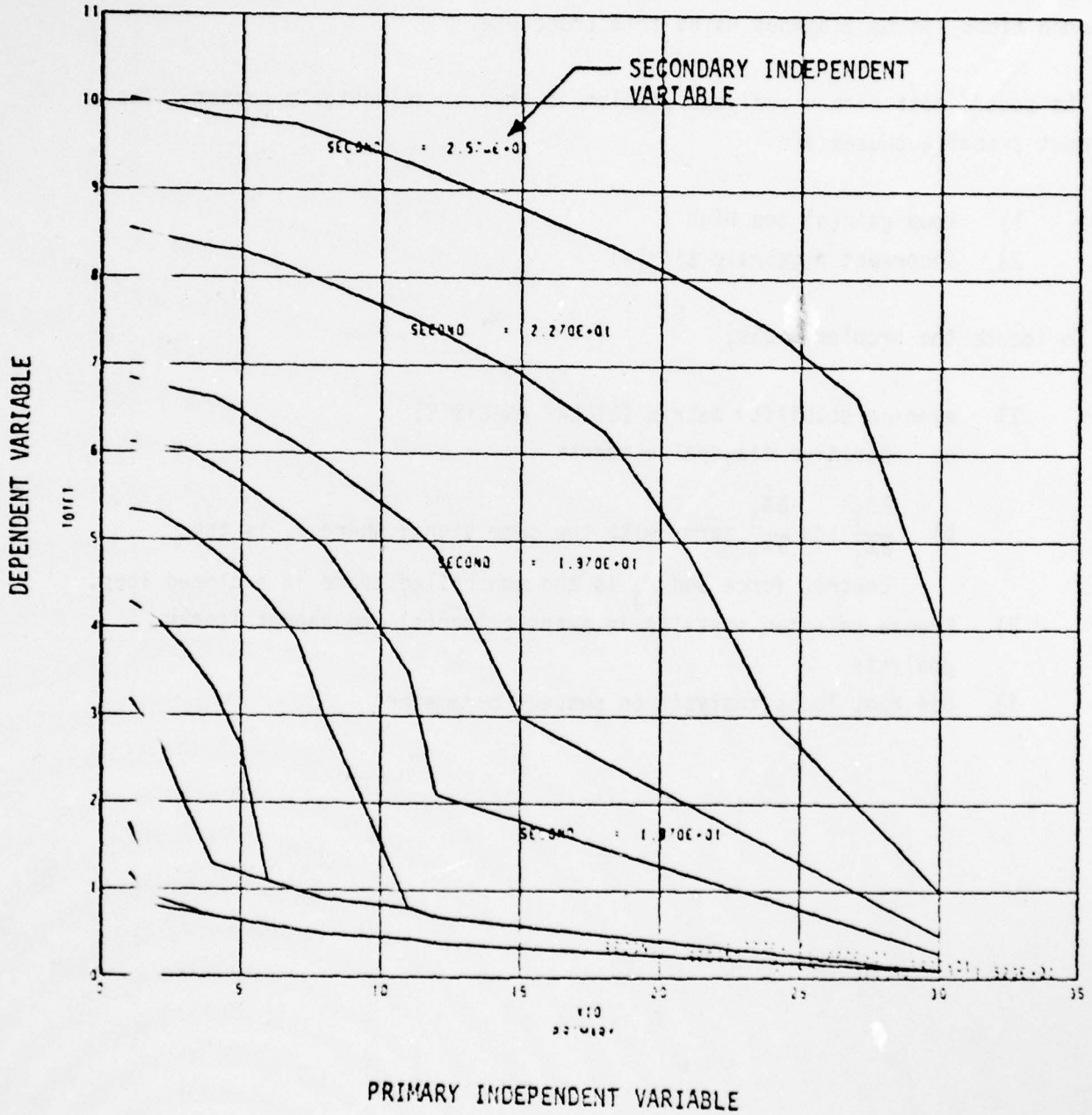

Figure 41 ACLS Fan Map as Plotted by EASY

Using PRINT CONTROL=6 will cause all states, rates and variables to be printed at each steady state iteration. Since we are interested in the impact of only the initial values of the state variables, the SS ITERATIONS command is used to limit this output to the first iteration.

The values of all variables which result from the user provided initial conditions can be examined using this procedure.

The second most common analysis problem is that of an unstable system. The most probable causes are:

- 1) loop gain(s) too high
- 2) incorrect algebraic sign(s)

To locate the problem areas,

- 1) examine stability matrix (LINEAR ANALYSIS)
  - a) positive diagonal elements
  - b)  $\frac{\partial \dot{x}_i}{\partial x_j}$  and  $\frac{\partial \dot{x}_j}{\partial x_i}$  terms with the same signs; where  $x_i$  is the control force and  $x_j$  is the controlled state in a closed loop.
- 2) Freeze selected state(s) in suspect loop(s) and repeat linear analysis
- 3) Use root locus analysis on suspect parameters

APPENDIX A

INDEX OF  
EASY MODEL GENERATION COMMANDS

Format	Description	Page
ADD PARAMETERS = $q_1, q_2, \dots$	Add parameters to model	12
ADD STATES = $q_1, q_2, \dots$	Add states to model	12
ADD TABLES = $t_1, n_1, t_2, n_2, \dots$	Add tables to model	12
ADD VARIABLES = $q_1, q_2, \dots$	Add variables to model	12
DIAGNOSTIC CONTROL = n	Control diagnostic printout form model generation program	[2]
END OF MODEL	Specify end of model description	11
FORTRAN STATEMENTS	Specify start of FORTRAN statements	12
$L_1$		
$L_2$		
INPUTS = $C_1, C_2, (q_{out} = q_{in}) \dots$	Specify source of inputs to components	10
LIST STANDARD COMPONENTS	Request listing of standard components	14
LOCATION = n, C	Specify component location on schematic	9
MODEL DESCRIPTION = text	Specify start of model description	9
O. C. ANALYSIS	Specify only analysis-no O.C. DESIGN	16
O. C. CRITERIA = $q_1, q_2, \dots$	Specify O.C. criteria variables	15
O. C. INPUTS = $q_1, q_2, \dots$	Specify O.C. input variables	14
O. C. MODEL ORDER = n	Specify model order to be used for O.C. DESIGN	15
O. C. ORDER = n	Specify optimal controller order	15
O. C. OUTPUTS = $q_1, q_2, \dots$	Specify O.C. output variables	14
PRINT	Request printed model output	11
PUNCH	Request punched (and printed) model output	11

## INDEX OF

### EASY MODEL GENERATION COMMANDS

#### Modifier Notions:

$C_i$  = Standard component name  
 $L_i$  = Line of FORTRAN source code  
 $n_i$  = Integer number  
 $q_i$  = Input or output quantity name  
 $t_i$  = Table name

#### Phrase Delimiters:

= equal sign  
, comma  
( left parenthesis  
) right parenthesis  
three or more blanks

## APPENDIX B

## INDEX OF

## EASY ANALYSIS COMMANDS

Format	Description	Page
ALL STATES	Activate <u>all</u> model states (DEFAULT)	175
CALCOMP	Request plots on CalComp plotter	[2]
DEFINE PARAMETERS= $n_1=p_1, n_2=p_2, \dots$	Define parameter names	191
DEFINE RATES= $n_1=r_1, n_2=r_2, \dots$	Define rate names	191
DEFINE STATES= $n_1=s_1, n_2=s_2, \dots$	Define state names	191
DEFINE VARIABLES= $n_1=v_1, n_2=v_2, \dots$	Define variable names	191
DESIGN O.C.	Initiate optimal controller design	196
DISPLAY <sub>i</sub> $i=1,2,3,4,5,6$ $q_1, vs, TIME$ $q_2, vs, q_3$ Max. 5/display	Specify quantities to be plotted (5 plots/display, 6 displays = max 30 plots)	180
EIGEN SENSITIVITY	Initiate eigenvalue sensitivity	189
EIGEN PARAMETER= $p_i$	calculation	189
ERROR CONTROL= $s_1=n_1, s_2=n_2, \dots$	Specify integrator error controls (DEFAULT=.001)	174
INITIAL CONDITIONS= $s_1=n_1, s_2=n_2, \dots$	Specify initial conditions/operating point	174
INITIAL TIME= $n$	Specify initial value of time (DEFAULT=0.)	175
INT CONTROL= $s_1=n_1, s_2=n_2, \dots$	Activate or freeze model states (DEFAULT=1)	174
LINEAR ANALYSIS	Initiate linear analysis	184
NO STATES	Freeze <u>all</u> model states	175
O.C. DATA	Input optimal controller data DEFAULT=0.)	192
YOP;UOP;Q;CD; CS;G;S;AK;FK		

INDEX OF  
EASY ANALYSIS COMMANDS

Format	Description	Page
PARAMETER VALUES= $p_1=n_1, p_2=n_2, \dots$	Input parameter values (DEFAULT=.99999)	172
PLOT ALL TABLES	Request plots of <u>all</u> tables	180
PLOT ID=text	Specify plot identification	182
PLOT OFF	Deactivate plotting (DEFAULT)	180
PLOT ON	Activate off-line plotting	180
PLOT TABLES= $t_1, t_2, \dots$	Request plots of specified tables	180
PRINT CONTROL=n	Specify print option (DEFAULT=0, Off)	180
PRINT VARIABLES= $q_1, q_2, \dots, q_{10}$	Specify columnar option print variables (PRINT CONTROL=5)	179
PRINTER PLOTS	Request plots on line printer	180
PUNCH X	Punch current state values	[2]
ROOT LOCUS	Initiate root locus analysis	188
RL PARAMETER=p	Specify root locus parameter	188
RL START=n	Specify initial value of RF PARAMETER	188
RL STOP=n	Specify final value of RL PARAMETER	188
RL POINTS=n	Specify number of root locus points	188
RL MANUAL SCALES	Request manual root locus plot scales	188
REAL MIN=n	Real axis minimum scale value	188
REAL MAX=n	Real axis maximum scale value	188

INDEX OF  
EASY ANALYSIS COMMANDS

Format	Description	Page
IMAG MIN=n	Imaginary axis min. scale value	189
IMAG MAX=n	Imaginary axis max. scale value	189
RL AUTO SCALES	Request auto plot scales (DEFAULT)	188
SAVE O.C.	Punch optimal controller arrays	196
SCAN1	Initiate one dimensional function scan	190
DEPEN=q	Specify dependent variable	190
INDEP1=q	Specify independent variable	190
START1=n	Specify initial value of INDEP1	190
STOP1=n	Specify final value of INDEP1	190
SCAN2	Initiate two dimensional function scan	190
INDEP2=q	Specify 2nd dependent variable	190
START2=n	Specify initial value of INDEP2	190
DELTA2=n	Specify increment size for INDEP2	190
CURVES2=n	Specify number of values for INDEP2	190
	(Also requires SCAN1 quantities)	
SC4020	Request plots on SC4020 microfilm	[2]

INDEX OF  
EASY ANALYSIS COMMANDS

Format	Description	Page
SIMULATE	Initiate simulation	176
PRINT CONTROL=n	Specify print option (DEFAULT=0, None)	176
PRATE=n	Request printout every n plot intervals (DEF=1)	176
OUTRATE=n	Request plot points every n TINC (DEF=1)	176
INT MODE=n	Specify integration method (DEF=6)	176
TINC=n	Specify integrator report interval (DEF=.1)	176
TMAX=n	Specify duration of transient (DEF=1.)	176
SI MANUAL SCALES	Request manual simulation plot scales	181
SI AUTO SCALES	Request auto plot scales (DEFAULT)	181
STABILITY MARGINS	Initiate stability margin calculation	185
SM PARAMETERS= $p_1, p_2, \dots, p_{10}$	Specify stability margin parameters	185
STEADY STATE	Initiate steady state calculation	183
SS PARAMETER=p	Specify steady state parameter (optional)	183
SS START=n	Specify initial value of SS PARAMETER	183
SS STOP=n	Specify final value of SS PARAMETER	183

INDEX OF  
EASY ANALYSIS COMMANDS

Format	Description	Page
SS POINTS=n	Specify number of steady state calculations	183
SS ITERATIONS=n	Specify number of iterations to be used (DEF=30)	183
SS MANUAL SCALES	Request manual plot scales	182
SS AUTO SCALES	Request auto plot scales (DEFAULT)	182
TABLE=t,n,n (table data)	Input tabular data	173
TITLE=text	Specify plot title.	182
TRANSFER FUNCTION	Initiate transfer function calculation	186
TF INPUT=q	Specify transfer function input quantity	186
TF OUTPUT=q	Specify transfer function output quantity	186
BODE	Request Bode format for plots (DEFAULT)	187
NICHOLS	Request Nichols format for plots	187
NYQUIST	Request Nyquist format for plots	187
TF MANUAL SCALES	Request manual plot scales	187
FREQ MIN=n	Specify minimum frequency r.p.s.	187
FREQ MAX=n	Specify maximum frequency r.p.s.	187
TF AUTO SCALES	Request auto plot scales (DEFAULT)	187

INDEX OF  
EASY ANALYSIS COMMANDS

Format	Description	Page
XIC-X	Transfer state to initial condition vector	175
XIC <sub>i</sub> -XIC    i=1,2,3	Transfer XIC to one of 3 storage vectors	175
XIC-XIC <sub>i</sub> i=1,2,3	Retrieve XIC from one of 3 storage vectors	175

Modifier Notation:

- $n_i$  - numeric value
- $p_i$  - parameter name
- $q_i$  - parameter, variable, state of rate name
- $r_i$  - rate name
- $s_i$  - state name
- $t_i$  - table name
- $v_i$  - variable name

Phrase Delimiters:

- = equal sign
- , comma
- ( left parenthesis
- ) right parenthesis
- three or more blanks

APPENDIX C

EASY DOCUMENTATION INDEX

The following index provides a cross reference for the following EASY ACLS documents:

- Volume I (Reference 1)
- Volume II (References 2 & 3)
- Volume III (Reference 4)
- Reference 6
- User's Manual (UM)

Capitalized words in the index are EASY Command Phrases.

ACLS Permanent File	Reference 6 - Pg 211, 223
ADD Commands	Reference 6 - Pg 19, 22, 34, 199; UM-Pg 12, 267
ALL STATES	Reference 6 - Pg 93; UM-Pg 175, 269
Analysis Program	Reference 6 - Pg 71, 232; UM-Pg 1, 172
AUTO SCALES	Reference 6 - Pg 103, 106, 107; UM-Pg 181, 182
BODE	Reference 6 - Pg 106; UM-Pg 187, 273
Component Connections	Reference 6 - Pg 17, 43, UM-Pg 19
Data Format	Reference 6 - Pg 120; UM-Pg 172
DATAIN, Subroutine	Reference 6 - Pg 63, UM-Pg 214
Deck Setup	Reference 6 - Pg 259
DEFINE Commands	Reference 6 - Pg 91; UM-Pg 191, 269
Delimiters	UM-Pg 7
DESIGN O.C.	Reference 6 - Pg 115; UM-Pg 196, 269
DIAGNOSTIC CONTROL	Reference 6 - Pg 32, 34, 199; UM-Pg 267
DISPLAY1	Reference 6 - Pg 94; UM-Pg 180, 269
DUMP FILE	Reference 6 - Pg 226
EIGEN PARAMETER	Reference 6 - Pg 109; UM-Pg 189
EIGEN SENSITIVITY	Reference 6 - Pg 78, 108; UM-Pg 189, 269
Eigenvalue	Reference 6 - Pg 135
Eigenvalue Sensitivity	Reference 6 - Pg 147
END OF MODEL	Reference 6 - Pg 18, 34, 199, 206; UM-Pg 11, 267
ERROR CONTROLS	Reference 6 - Pg 61, 92; UM-Pg 174, 269
EQMO, Subroutine	Reference 6 - Pg 63, UM-Pg 209

FILOAD Program	Reference 6 - Pg 225
FORTRAN STATEMENTS	Reference 6 - Pg 19, 22, 34, 199, 210; UM-Pg 12, 267
FUNCTION SCAN	Reference 6 - Pg 85, 109, 149
INITIAL CONDITIONS	Reference 6 - Pg 61, 92; UM-Pg 174, 269
INITIAL TIME	Reference 6 - Pg 92; UM-Pg 175, 269
INPUTS	Reference 6 - Pg 14, 34, 199, 204; UM-Pg 10, 267
INT CONTROLS	Reference 6 - Pg 92; UM-Pg 174, 269
INT MODE	Reference 6 - Pg 97; UM-Pg 176, 177, 272
Input Requirements List	Reference 6 - Pg 57
LINEAR ANALYSIS	Reference 6 - Pg 76, 103; UM-Pg 184, 269
Lineprinter Schematic	Reference 6 - Pg 9, 38
Listings	
Compass Routines	Reference 6 Pt 2 - Pg 320
Fluid Flow Routines	Volume II - Pg 12
Fluid Property Routines	Volume II - Pg 11
Miscellaneous Routines	Volume II - Pg 30
Model Analysis Program	Reference 6 Pt 2 - Pg 75
Model Generation Program	Reference 6 Pt 2 - Pg 3
Permanent File Maintenance Program	Reference 6 Pt 2 - Pg 252
Plotting Routines	Reference 6 Pt 2 - Pg 269
Standard Components	Volume II - Pg 52
Transfer Function Routines	Volume II - Pg 17
LIST STANDARD COMPONENTS	Reference 6 - Pg 25, 27, 34, 199, 225; UM-Pg 14, 267

LOCATION	Reference 6 - Pg 12, 22, 34, 199, 200; UM-Pg 9, 267
MANUAL SCALES	Reference 6 - Pg 103, 106, 107; UM-Pg 181, 182
Mathematical Models	Volume I
MODEL DESCRIPTION	Reference 6 - Pg 12, 22, 34, 199; UM-Pg 5, 9, 267
Model Generation Program	Reference 6 - Pg 6, 195; UM-Pg 1, 4
Naming Conventions	Reference 6 - Pg 32; Um-Pg 16
NEW FILE	Reference 6 - Pg 226
NICHOLS	Reference 6 - Pg 106; UM-Pg 187, 273
NO STATES	Reference 6 - Pg 93; UM-Pg 175, 269
NYQUIST	Reference 6 -Pg 106; UM-Pg 187, 273
O.C. ANALYSIS	Reference 6 - Pg 31, 34, 199; UM-Pg 16, 267
O.C. CRITERIA	Reference 6 - Pg 29, 34, 199; UM-Pg 15, 267
O.C. DATA	Reference 6 - Pg 110; UM-Pg 192, 269
O.C. INPUTS	Reference 6 - Pg 26, 34, 199; UM-Pg 14, 267
O.C. MODEL ORDER	Reference 6 - Pg 31, 34, 199; UM-Pg 15, 267
O.C. ORDER	Reference 6 - Pg 31, 34, 199; UM-Pg 15, 267
O.C. OUTPUTS	Reference 6 - Pg 26, 34, 199; UM-Pg 14, 267
Optimal Controller Design	Reference 6 - Pg 85, 110, 150; UM-Pg 192
OUTRATE	Reference 6 - Pg 96; UM-Pg 176, 272
Overlay	Reference 6 - Pg 236
PARAMETER VALUES	Reference 6 - Pg 93; UM-Pg 172, 270
Permanent File Maintenance Program	Reference 6 - Pg 240
PLOT ALL TABLES	Reference 6 - Pg 95; UM-Pg 180, 270
PLOT ID	Reference 6 - Pg 94; UM-Pg 182, 270

AD-A081 160 BOEING AEROSPACE CO SEATTLE WA BOEING MILITARY AIRPL--ETC F/G 9/2  
EASY-ACIS DYNAMIC ANALYSIS. USER'S MANUAL. (U)  
UNCLASSIFIED SEP 79 M K WAHI, G S DULEBA, P R PERKINS F33615-77-C-3054  
AFFDL-TR-79-3106 NL

4 of 4

AD  
A081160



END  
DATE  
FILMED  
3-80  
DDC

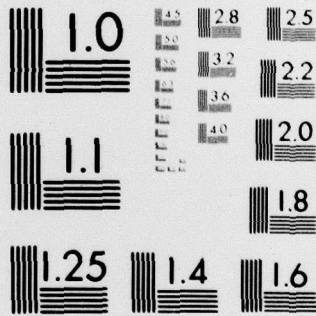

MICROCOPY RESOLUTION TEST CHART  
NATIONAL BUREAU OF STANDARDS-1963-A

PLOT OFF	Reference 6 - Pg 93; UM-Pg 180, 270
PLOT ON	Reference 6 - Pg 93; UM-Pg 180, 270
PLOT TABLES	Reference 6 - Pg 95; UM-Pg 180, 270
PRATE	Reference 6 - Pg 96; UM-Pg 176, 272
PRINT	Reference 6 - Pg 19, 34, 199; UM-Pg 11, 267
PRINT CONTROL	Reference 6 - Pg 98; UM-Pg 176, 178, 183, 270
PRINTER PLOTS	Reference 6 - Pg 93; UM-Pg 180, 270
PRINT VARIABLES	Reference 6 - Pg 100; UM-Pg 179, 269
Program Limitations	Reference 6 - Pg 230; UM-Pg 257
PUNCH	Reference 6 - Pg 19, 34, 199; UM-Pg 11, 267, 270
PURGE	Reference 6 - Pg 225
ROOT LOCUS	Reference 6 - Pg 78, 107, 146; UM-Pg 188, 270
SAVE O.C.	Reference 6 - Pg 115; UM-Pg 196, 271
SCAN 1, SCAN 2	UM-Pg 190, 271
SIMULATE	Reference 6 - Pg 96; UM-Pg 176, 272
Simulation	Reference 6 - Pg 71, 123
STABILITY MARGINS	Reference 6 - Pg 76, 105, 137; UM-Pg 185, 272
Stability Matrix	Reference 6 - Pg 131
STEADY STATE	Reference 6 - Pg 74, 101, 128, UM-Pg 183, 272
SYMBOL	Reference 6 - Pg 40, 225
TABLE	Reference 6 - Pg 120; UM-Pg 173, 273
TINC	Reference 6 - Pg 96; UM-Pg 176, 272
TITLE	Reference 6 - Pg 94; UM-Pg 182, 273

TRANSFER FUNCTION	UM-Pg 186, 273
TMAX	Reference 6 - Pg 78, 106, 142; UM-Pg 176, 272
Warning Messages	Reference 6 - Pg 66, 180; UM-Pg 21, 196
Worked Examples	Volume III; UM-Pg 204
XIC Commands	Reference 6 - Pg 95; UM-Pg 175, 274

## LIST OF REFERENCES

1. Wah, M. K., Duleba, G. S., Kilner, J. R., Perkins, P. R., EASY-ACLS Dynamic Analysis. Volume I. Component Mathematical Models, AFFDL-TR-70-3105, Vol. I, September 1979 (In Press).
2. Wah, M. K., Duleba, G. S., Perkins, P. R., EASY-ACLS Dynamic Analysis. Volume II. Component Computer Program, AFFDL-TR-79-3105, Vol. II, Part I, September 1979 (In Press).
3. Wah, M. K., Duleba, G. S., Perkins, P. R., EASY-ACLS Dynamic Analysis. Volume II. Component Computer Program, AFFDL-TR-79-3105, Vol. II, Part II, September 1979 (In Press).
4. Wah, M. K., Perkins, P. R., Kilner, J. R., EASY-ACLS Dynamic Analysis. Volume III. Description of Simulations, AFFDL-TR-79-3105, Vol. III, September 1979 (In Press).
5. Application of the EASY Dynamic Analysis Program to Aircraft Modeling, Users Manual, Boeing Document BCS 40120 (Contract F33615-76-C-3165), November 15, 1976.
6. Environmental Control System (ECS) Transient Analysis, Volume III, Part I, Integrated Transient Computer Program - Users Guide, AFFDL-TR-77-102, (Contract F33615-76-C-3100), July, 1977.
7. Optimal Control, McGraw-Hill, 1966, M. Athans and P. L. Falb.
8. Dynamics of Atmospheric Flight, Wiley, 1972, B. Etkin.
9. Aircraft Dynamics and Automatic Control, Princeton, 1973, McRuer, Ashkenas, and Graham.
10. Aerodynamics Technical Memo 222, "Test Data - Low Speed Wind Tunnel Tests of Jindivik MK 3A Carrying MK 7 Pods", T. H. Trimble and M. K. Politz, Dept. of Supply, Australian Defense Scientific Service Aeronautical Research Laboratories, no date.
11. An Appendix - "Aerodynamic Derivatives and Autopilot/Servo Transfer Functions for MK 203A Short Span Jindivik Fitted with MK 4/8 Wing Tip Fuel Pods", - Government Aircraft Factories, no date.