

AD-A081 239

ITT ELECTRO-OPTICAL PRODUCTS DIV ROANOKE VA F/8 20/6
STUDY OF THE EFFECTS OF BENDING AND MICROBENDING ON GLASS FIBER--ETC(U)
NOV 79 F I AKERS, S L MAHURIN N00014-78-C-0852

UNCLASSIFIED

ITT-79-35-048

NL

1 OF 1
AD
208-3-14

END
DATE
FILMED
3-80
DOC

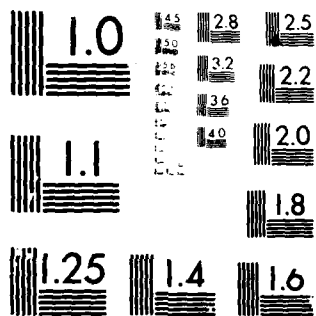

MICROCOPY RESOLUTION TEST CHART
NATIONAL BUREAU OF STANDARDS-1963-A

FINAL TECHNICAL REPORT

12

LEVEL

STUDY OF THE EFFECTS
OF BENDING AND MICROBENDING
ON GLASS FIBERS

DTIC
ELECTE

1 OCTOBER 1978 TO 30 NOVEMBER 1979
CONTRACT NO. N00014-78-C-0852

PREPARED BY:

ITT *Electro-Optical Products Division*
7635 Plantation Road, Roanoke, Va. 24019

This document has been approved
for public release and sale; its
distribution is unlimited.

PREPARED FOR:

OFFICE OF NAVAL RESEARCH
800 N. QUINCY ST.
ARLINGTON, VIRGINIA 22217

79 125 002

ADA 081 239

DOC FILE COPY

⑥ STUDY OF THE EFFECTS OF BENDING AND MICROBENDING ON GLASS FIBERS.

⑨ Final Report.
1 Oct 1978 to 30 Nov 1979

Contract Number: N00014-78-C-0852

⑩
⑪ 28 Nov 79

⑫ 92
Prepared by
⑬ Frank I. Akers L. Mahurin
Steven

ITT ELECTRO-OPTICAL PRODUCTS DIVISION
P. O. Box 7065
Roanoke, Virginia 24019

for

Office of Naval Research
800 North Quincy Street
Arlington, Virginia 22217

⑭ ITTL-79-35-44B

Approved by:
[Signature]
R. E. Thompson, Manager,
Fiber and Cable R&D
November 28, 1979

Approved by:
[Signature]
F. R. McDevitt, Director,
Fiber Optics R&D and Systems
Doc Id No: 79-35-04B

Roanoke, Virginia

189750

Unclassified

SECURITY CLASSIFICATION OF THIS PAGE (When Data Entered)

REPORT DOCUMENTATION PAGE		READ INSTRUCTIONS BEFORE COMPLETING FORM
1. REPORT NUMBER	2. GOVT ACCESSION NO.	3. RECIPIENT'S CATALOG NUMBER
4. TITLE (and Subtitle) STUDY OF THE EFFECTS OF BENDING AND MICROBENDING ON GLASS FIBERS		5. TYPE OF REPORT & PERIOD COVERED Final 10/1/78 - 11/30/79
7. AUTHOR(s) Frank I. Akers and Steven L. Mahurin		6. PERFORMING ORG. REPORT NUMBER
9. PERFORMING ORGANIZATION NAME AND ADDRESS ITT ELECTRO-OPTICAL PRODUCTS DIVISION P.O. Box 7065 Roanoke, VA 24019		8. CONTRACT OR GRANT NUMBER(s) N00014-78-C-0852
11. CONTROLLING OFFICE NAME AND ADDRESS Office of Naval Research 800 N. Quincy Street Arlington, Virginia 22217		10. PROGRAM ELEMENT, PROJECT, TASK AREA & WORK UNIT NUMBERS
14. MONITORING AGENCY NAME & ADDRESS (if different from Controlling Office) Office of Naval Research 800 N. Quincy Street Arlington, Virginia 22217		12. REPORT DATE November 28, 1979
		13. NUMBER OF PAGES 84
		15. SECURITY CLASS. (of this report) Unclassified
		15a. DECLASSIFICATION/DOWNGRADING SCHEDULE
16. DISTRIBUTION STATEMENT (of this Report)		
17. DISTRIBUTION STATEMENT (of the abstract entered in Block 20, if different from Report)		
18. SUPPLEMENTARY NOTES		
19. KEY WORDS (Continue on reverse side if necessary and identify by block number) Monomode Waveguide, High NA, Bending Loss, Microbending Loss, Acoustic Sensor		
20. ABSTRACT (Continue on reverse side if necessary and identify by block number) Single mode fibers are being used as media for acoustic sensors based on optical phase change detection. Deployment of this type of sensor requires the optical fiber to be tightly coiled around a small diameter mandrel. This tight coiling has been found to increase the fiber attenuation through bending and micro- bending loss mechanisms. As a result, ITT EOPD was awarded contract N00014-78-C-0852 by the Office of Naval Research, which allows for an investigation of mechanisms of optical losses in glass fibers under states of		

DD FORM 1 JAN 73 1473 EDITION OF 1 NOV 68 IS OBSOLETE

Unclassified

SECURITY CLASSIFICATION OF THIS PAGE (When Data Entered)

20. Abstract (continued)

bending and microbending and a study of relationships between optical loss mechanisms and glass composition for development of low loss wide aperture fibers.

Both high and low NA single mode fibers were fabricated using core compositions of SiO₂/GeO₂ and SiO₂/P₂O₃. The fiber preforms were fabricated both by the conventional one-step technique and also by a two-step rod-in-tube technique, in order to reduce waveguide imperfections. The fibers in this array of eight different fiber types were evaluated for attenuation while unstressed, attenuation when bent around a mandrel, and attenuation while subjected to microbends.

While the low NA fibers of all types showed significant bend and microbend induced losses, the high NA fibers showed very small induced losses. The one-step high NA germanosilicate core fiber exhibited negligible bending and microbending losses under all circumstances. The one-step high NA germanosilicate core fiber was selected for the jacket evaluation, wherein four fibers were drawn from a single one-step high NA germanosilicate core preform. These fibers were coated with hard or soft primary and secondary jackets in all combinations. On the basis of this single test, the combination of "hard" silicone primary coating and "hard" polyester jacket showed the least amount of induced loss from bending and microbending. When 30 m of high NA fiber were wrapped around an 8 mm mandrel, the resulting attenuation increase was less than 0.3 dB.

Accession For	
DTIC	GRA&I
DDC	FAB
Unannounced	
Justification	
By	<i>[Signature]</i>
Distribution/	
Availability Codes	
Dist	Avail and/or special
A	

ABSTRACT

Single mode fibers are being used as media for acoustic sensors based on optical phase change detection. Deployment of this type of sensor requires the optical fiber to be tightly coiled around a small diameter mandrel. This tight coiling has been found to increase the fiber attenuation through bending and microbending loss mechanisms. As a result, ITT EOPD was awarded contract N00014-78-C-0852 by the Office of Naval Research, which allows for an investigation of mechanisms of optical losses in glass fibers under states of bending and microbending and a study of relationships between optical loss mechanisms and glass composition for development of low loss wide aperture fibers.

Both high and low NA single mode fibers were fabricated using core compositions of $\text{SiO}_2/\text{GeO}_2$ and $\text{SiO}_2/\text{P}_2\text{O}_3$. The fiber preforms were fabricated both by the conventional one-step technique and also by a two-step rod-in-tube technique, in order to reduce waveguide imperfections. The fibers in this array of eight different fiber types were evaluated for attenuation while unstressed, attenuation when bent around a mandrel, and attenuation while subjected to microbends.

Roanoke, Virginia

ITT *Electro-Optical Products Division*

While the low NA fibers of all types showed significant bend and microbend induced losses, the high NA fibers showed very small induced losses. The one-step high NA germanosilicate core fiber exhibited negligible bending and microbending losses under all circumstances. The one-step high NA germanosilicate core fiber was selected for the jacket evaluation wherein four fibers were drawn from a single one-step high NA germanosilicate core preform. These fibers were coated with hard or soft primary and secondary jackets in all combinations. On the basis of this single test, the combination of "hard" silicone primary coating and "hard" polyester jacket showed the least amount of induced loss from bending and microbending. When 30 m of high NA fiber were wrapped around an 8 mm mandrel, the resulting attenuation increase was less than 0.3 dB.

TABLE OF CONTENTS

<u>PARAGRAPH</u>	<u>TITLE</u>	<u>PAGE</u>
1.0	INTRODUCTION	1-1
2.0	SINGLE MODE FIBER BEND LOSS STUDY	2-1
2.1	Fiber Design	2-2
2.2	Fabrication Technique	2-4
2.2.1	One-step Preform Fabrication	2-5
2.2.2	Two-step Preform Fabrication	2-8
2.2.3	Fiber Drawing and Coating	2-8
2.2.4	Special Coatings	2-10
2.3	Evaluation	2-12
2.3.1	Optical Evaluation	2-12
2.3.2	Bending Loss Evaluation	2-17
2.3.3	Microbending Loss Evaluation	2-38
2.3.4	Coating and Jacketing Evaluation	2-51
2.3.5	Eight Millimeter Mandrel Test	2-54
3.0	CONCLUSIONS AND RECOMMENDATIONS	3-1
APPENDIXES		
A	Bend Loss Plots: Test 2	A-1
B	Jacket Evaluation: Bend Loss Plots	B-1
C	Jacket Evaluation: Microbend Loss Plots	C-1

LIST OF ILLUSTRATIONS

<u>FIGURE</u>	<u>TITLE</u>	<u>PAGE</u>
2.2.1-1	Single Mode Fiber Fabrication Methods	2-6
2.2.3-1	Optical Fiber Drawing Apparatus	2-9
2.3.1-1	Attenuation Measurement Equipment	2-14
2.3.2-1	Excess Loss Measurement Equipment	2-18
2.3.2-2	Monitoring Coupler	2-20
2.3.2-3	Monitoring Coupler Housing	2-21
2.3.2-4	Coupler Performance Data Sheet	2-22
2.3.2-5	Bend Loss Evaluation Data Sheet	2-24
2.3.2-6	Single Mode Fiber Bending Loss Test Apparatus	2-25
2.3.2-7	Bend Loss Test Results for EMT-20721	2-27
2.3.2-8	Bend Loss Test Results for EMT-20738	2-28
2.3.2-9	Bend Loss Test Results for EM-20495	2-29
2.3.2-10	Bend Loss Test Results for EMH-20627	2-30
2.3.2-11	Bend Loss Test Results for EMT-20710A	2-31
2.3.2-12	Bend Loss Test Results for EMT-20783	2-32
2.3.2-13	Bend Loss Test Results for EMH-20726B	2-33
2.3.2-14	Bend Loss Test Results for EMH-20730	2-34
2.3.2-15	Bend Loss Test Results Summary: 20 Turns, 6.4 mm Mandrel	2-36
2.3.2-16	Bend Loss Test Results Summary: 20 Turns, 3.2 mm Mandrel	2-37
2.3.3-1	Single Mode Fiber Microbend Loss Test Apparatus	2-39
2.3.3-2	Microbend Loss Data Sheet	2-41
2.3.3-3	Microbend Loss Test Results for EMT-20721	2-42
2.3.3-4	Microbend Loss Test Results for EMT-20738	2-43
2.3.3-5	Microbend Loss Test Results for EMT-20710A	2-44
2.3.3-6	Microbend Loss Test Results for EMT-20783	2-45
2.3.3-7	Microbend Loss Test Results for EM-20495	2-46
2.3.3-8	Microbend Loss Test Results for EMH-20627	2-47
2.3.3-9	Microbend Loss Test Results for EMH-20726B	2-48
2.3.3-10	Microbend Loss Test Results for EMH-20730	2-49
2.3.4-1	Jacket Evaluation - Bend Loss Test Results	2-53
2.3.4.2	Jacket Evaluation: Microbend Loss Test Results	2-55
2.3.5-1	Eight Millimeter Mandrel Test Results	2-56

LIST OF ILLUSTRATIONS (Continued)

<u>FIGURE</u>	<u>TITLE</u>	<u>PAGE</u>
A-1	EMT-20721 Bend Loss Results: Test 2	A-2
A-2	EMT-20738 Bend Loss Results: Test 2	A-3
A-3	EM-20495 Bend Loss Results: Test 2	A-4
A-4	EMH-20627 Bend Loss Results: Test 2	A-5
A-5	EMT-20710A Bend Loss Results: Test 2	A-6
A-6	EMT-20783 Bend Loss Results: Test 2	A-7
A-7	EMH-20726B Bend Loss Results: Test 2	A-8
A-8	EMH-20730 Bend Loss Results: Test 2	A-9
B-1	Soft/soft Jacket Bend: Test 1	B-2
B-2	Soft/soft Jacket Bend: Test 2	B-3
B-3	Soft/hard Jacket Bend: Test 1	B-4
B-4	Soft/hard Jacket Bend: Test 2	B-5
B-5	Hard/soft Jacket Bend: Test 1	B-6
B-6	Hard/soft Jacket Bend: Test 2	B-7
B-7	Hard/hard Jacket Bend: Test 1	B-8
B-8	Hard/hard Jacket Bend: Test 2	B-9
C-1	Soft/soft Jacket Microbend Test Results	C-2
C-2	Soft/hard Jacket Microbend Test Results	C-3
C-3	Hard/soft Jacket Microbend Test Results	C-4
C-4	Hard/hard Jacket Microbend Test Results	C-5

LIST OF TABLES

<u>TABLE</u>	<u>TITLE</u>	<u>PAGE</u>
2.2.1-1	Single Mode Fiber Fabrication Data	2-7
2.2.4-1	Properties of Special Coating Materials	2-11
2.3.1-1	Single Mode Fiber Loss Data	2-16
2.3.3-1	Microbend Loss Test Result Summary	2-50
2.3.4-1	Optical Parameters for Fiber EMH-20807	2-52

1.0 INTRODUCTION

Single mode fibers are being used as media for acoustic sensors based on optical phase change detection. Deployment of this type of sensor requires the optical fiber to be tightly coiled around a small diameter mandrel. Tight coiling has been found to increase the fiber attenuation through bending and microbending loss mechanisms. As a result, ITT EOPD was awarded contract N00014-78-C-0852 by the Office of Naval Research, which allows for an investigation of mechanisms of optical losses in glass fibers under states of bending and microbending and a study of relationships between optical loss mechanisms and glass composition for development of low loss wide aperture fibers.

The research program specified in Contract N00014-78-C-0852 was conducted with the following objectives:

- a. Development of preforms and fibers having NA values of <0.15 and >0.15 , with phosphosilicate and germanosilicate core compositions, using one-step and two-step preform types
- b. Evaluation of bending losses in single mode fibers with respect to NA, core composition, and preform type
- c. Evaluation of microbending losses in single mode fiber with respect to NA, core composition, and preform type
- d. Evaluation of fiber bending and microbending losses in one selected fiber type which is coated with four different primary and secondary jacket hardness combinations

Roanoke, Virginia

- e. Evaluation of fiber attenuation in 30 m length wrapped on 8 mm diameter mandrel

All of the above objectives were met. Core compositions of $\text{SiO}_2/\text{GeO}_2$ and $\text{SiO}_2/\text{P}_2\text{O}_3$ were used to fabricate both high NA and low NA single mode fibers. The fiber preforms were fabricated both by the conventional one-step technique and by a two-step rod-in-tube technique, in order to reduce waveguide imperfections. The fibers in this array of eight different fiber types were evaluated for attenuation while unstressed, attenuation when bent around a mandrel, and attenuation while subjected to microbends. While the low NA fibers of all types showed significant bend and microbend induced losses, the high NA fibers showed very small induced losses. The one-step high NA germanosilicate core fiber exhibited negligible bending and microbending losses under all circumstances. This design was, therefore, selected for the jacket evaluation wherein four fibers were drawn from a single one-step high NA germanosilicate core preform. These fibers were coated with hard or soft primary and secondary jackets in all combinations. The combination of "hard" silicone primary coating and "hard" polyester jacket showed the least amount of induced loss from bending and microbending. When 30 m of high NA fiber were wrapped around an 8 mm diameter mandrel, the resulting attenuation increase was less than 0.3 dB.

ITT *Electro-Optical Products Division*

2.0 SINGLE MODE FIBER BEND LOSS STUDY

ITT EOPD is currently producing single mode fibers for a variety of customer applications, including fiber gyros and acoustic sensors. The standard ITT type T-110 single mode fiber has a 0.1 NA and a core diameter of 4.4 μm . Attenuation values as low as 2 dB/km at 0.85 μm have been achieved for this fiber when evaluated in an unstressed configuration, and a value of 3.8 dB/km has been measured in a 1200 m long T-110 fiber which was level wound onto a 30 cm diameter spool. However, the optical loss increases to more than 40 dB/km when the T-110 fiber is spooled onto a 10 cm diameter spool.

To reduce bending and microbending losses in single mode fibers EOPD has developed an 0.2 NA single mode fiber under NRL Contract N00173-78-C-0196. This fiber was developed using three different core compositions of $\text{SiO}_2/\text{GeO}_2$, $\text{SiO}_2/\text{P}_2\text{O}_5$, and $\text{SiO}_2/\text{GeO}_2/\text{P}_2\text{O}_5$. The 0.2 NA fiber has a 2.2 μm core diameter and was evaluated for attenuation in two configurations: (1) unstressed while strung between two 30 cm diameter drums and (2) spooled onto a standard 10 cm diameter fiber spool. The 0.2 NA fiber had no measurable loss increase with respect to the strung configuration when wound onto the 10 cm diameter spool.

Roanoke, Virginia

In order to fully evaluate single mode fiber bending and microbending losses, preforms and fibers were fabricated having high and low NA, having germanosilicate and phosphosilicate core compositions, and using one-step and two-step preform fabrication techniques. The two-step preform was designed to reduce scattering loss in single mode fibers by reducing the thicknesses of depletion layers between the core and cladding layers.

In addition, to evaluate the effects of primary and secondary jacket hardness on bend and microbend loss, fibers were fabricated with four combinations of hard and soft coatings. Special test equipment and procedures were developed for valid evaluation of both bending and microbending losses. The remainder of this section describes the design, fabrication, and evaluation of the single mode fiber types described above.

2.1 Fiber Design

In a single mode fiber, the normalized core diameter V_c must be small so that only the fundamental HE_{11} mode will propagate. This condition is satisfied when $V_c < 2.405$, which is the cut-off value V_{c0} for the LP_{11} second order mode. The normalized core diameter is related to the fiber core diameter (d_c), numerical aperture (NA), and operating wavelength (λ) through the equation:

$$V_c = \frac{dc \pi NA}{\lambda} \quad (1)$$

The HE_{11} mode has no cut off, but as V_c becomes smaller the normalized mode diameter increases such that the mode becomes weakly guided and becomes susceptible to bending and microbending losses.

Although the least bend-sensitive fiber would have a V_c value approaching 2.405, a smaller V_c design value must be used since practical uncertainties in measurement of preform core NA and preform core diameter, and variations in fiber diameter during drawing cause an uncertainty in the actual fiber V_c value which can result in multimode operation. Fibers for this study were designed having $V_c = 0.9 V_{c0} = 2.2$ at $0.63 \mu\text{m}$ wavelength. Thus, selection of nominal fiber NA values of 0.1 and 0.2 fixed the core diameters at $4.4 \mu\text{m}$ and $2.2 \mu\text{m}$ respectively, according to equation 1.

The fiber NA results from reducing the cladding refractive index or raising the core refractive index or both. Typically, B_2O_3 is added as a dopant to SiO_2 to reduce the cladding index while the core index is increased by the addition of GeO_2 or P_2O_5 to the base SiO_2 glass. Since an increase in core dopant level usually leads to an increase in Rayleigh and non-Rayleigh scattering losses of the core glass, a design goal

was to minimize core dopant concentration. As a result, metered dopant levels in the 0.1 NA fiber were <5% GeO₂ or P₂O₅ by weight with a 5% B₂O₃ cladding dopant level. In the high NA fibers, the cladding refractive index was depressed to near its minimum value reported at 15.7% B₂O₃. Furthermore, the core dopant level was adjusted to achieve the desired NA. Because an appreciable portion of the light power propagates in the cladding portion of a single mode fiber, the cladding thickness was designed to be at least eight times the core radius. This insured that most of the field is contained within the high purity deposited cladding material and that inward diffusion of impurities from the starting substrate has a minimal effect on optical transmission.

2.2 Fabrication Technique

Single mode optical fiber preforms were fabricated using two methods. The first method was the standard "one-step" process where high purity cladding and core glasses are chemically vapor deposited inside a silica substrate tube which is subsequently collapsed into a solid rod. The second method utilized a large core preform rod as prepared in the first method, but which was then placed inside a substrate tube which was collapsed to form a large diameter two-step preform.

The preform fabrication and drawing, as well as coating and evaluation of single mode fibers are described in the following sections.

2.2.1 One-step Preform Fabrication

Fiber preforms were fabricated by chemical vapor deposition, using mass flow control of chemical reactants. Bubble free high purity natural fused quartz tubing was used for the substrate material, into which optical cladding and core materials were deposited, as shown in Figure 2.2.1-1. Table 2.2.1-1 summarizes the core and cladding compositions and the core and cladding passes used for the one-step preforms as well as the two-step preforms which will be discussed in the next section. The low NA preforms required 10 passes of core in order to provide a fiber having a 4.4 μm core in about 80 μm OD fiber. Fewer core passes were used for the high NA preform so that a 2.2 μm core can be obtained in an 80 μm fiber. The cladding and core dopant concentrations were adjusted to produce the desired NA value. After the deposition was completed, the preform tube was flame heated and collapsed to a solid rod. This preform was then drawn to the diameter necessary to yield a fiber having $V_c = 2.2$ at 0.63 μm .

Roanoke, Virginia

ONE - STEP METHOD

TWO - STEP METHOD

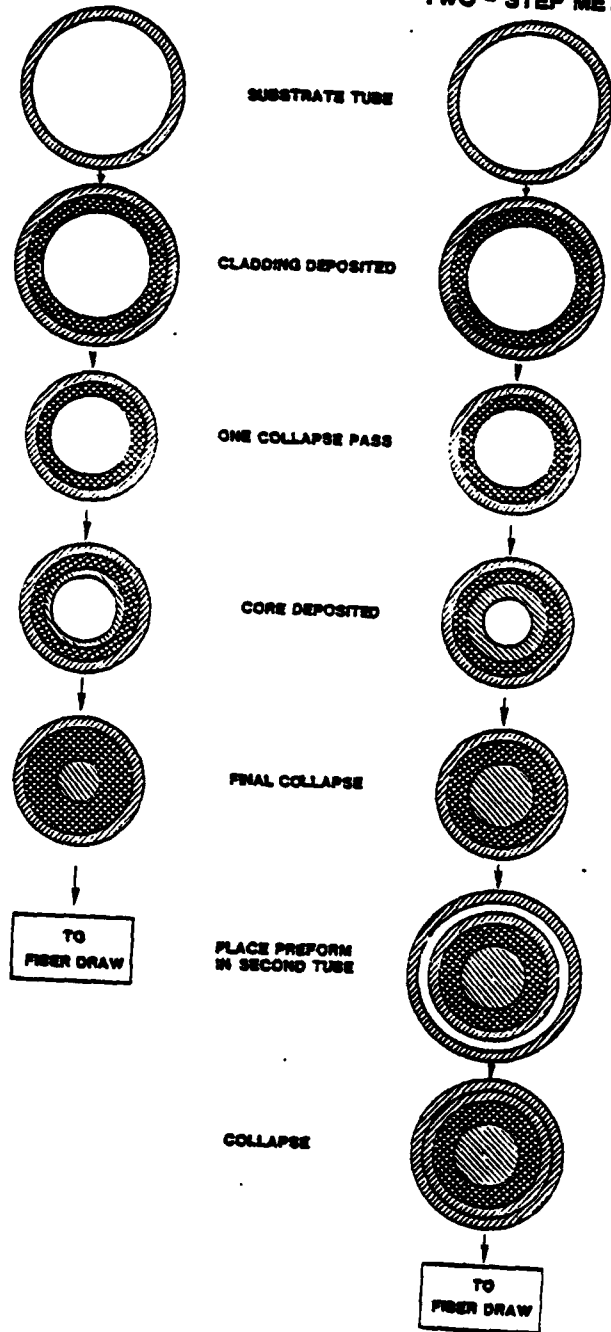

102 12236

Figure 2.2.1-1. Single Mode Fiber Fabrication Methods.

Table 2.2.1-1. Single Mode Fiber Fabrication Data.

<u>Preform No.</u>	<u>Fab Method</u>	<u>Core Composition</u>	<u>NA (± 0.01)</u>	<u>Core Passes</u>	<u>Clad Passes</u>	<u>WT % B₂O₃ In Clad³</u>	<u>WT % Core Dopant</u>
EMT-20721	1 Step	SiO ₂ /GeO ₂	0.11	10	50	4.8	4.3
EMT-20738	1 Step	SiO ₂ /P ₂ O ₅	0.11	10	50	4.8	1.8
EM-20495	1 Step	SiO ₂ /GeO ₂	0.21	3	50	13.7	36.1
EMH-20627	1 Step	SiO ₂ /P ₂ O ₅	0.17	5	50	4.8	14.1
EMT-20710A	2 Step	SiO ₂ /GeO ₂	0.12	10	40	8.0	4.3
EMT-20783	2 Step	SiO ₂ /P ₂ O ₅	0.11	15	40	4.8	1.8
EMH-20726B	2 Step	SiO ₂ /GeO ₂	0.19	10	25	13.7	36.2
EMH-20730	2 Step	SiO ₂ /P ₂ O ₅	0.19	16	25	13.7	16.2

2.2.2 Two-step Preform Fabrication

Figure 2.2.1-1 illustrates the differences in the two-step method as compared to the one-step method. A preform is fabricated which has a thinner cladding or a larger core or both. This preform is placed inside a second substrate tube which is collapsed over the preform. The final preform has a larger core diameter and a larger OD than a one-step preform. The fabrication parameters used for two-step preform fabrication are listed in Table 2.2.1-1.

2.2.3 Fiber Drawing and Coating

The preforms were drawn to fibers of the desired diameter with the equipment shown schematically in Figure 2.2.3-1. The preforms were drawn using a graphite resistance furnace.

The fiber diameter was monitored continuously and was controlled within $\pm 2\%$. Fibers were dip coated on-line with a primary coating of low modulus silicone resin Sylgard[®] 184, to a nominal diameter of 300 μm . Also, a secondary jacket of Hytrel[®] type 72D jacket was extruded on-line to a nominal final diameter of 400 μm . The fibers were collected on 10 cm diameter spools as they were drawn.

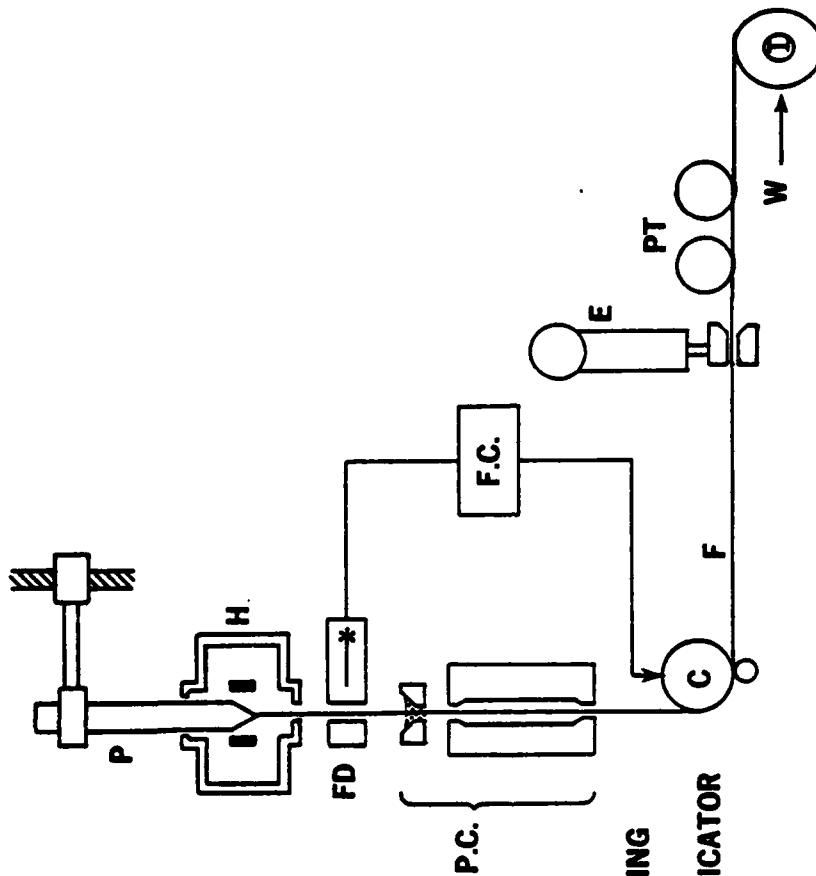

- P: PREFORM**
- H: RESISTANCE FURNACE**
- FD: FIBER DIAMETER MEASURING INSTRUMENT**
- P.C.: PRIMARY COATING APPLICATOR**
- C: CAPSTAN**
- F: FIBER**
- W: TAKE-UP DRUM**
- F.C.: FEEDBACK CIRCUIT**
- E: EXTRUDER**
- I: IN LINE LOSS MEASUREMENT-**
- PT: PROOF TESTER**

Figure 2.2.3-1. Optical Fiber Drawing Apparatus.

2.2.4 Special Coatings

To evaluate primary and secondary jacket hardness effects on bend and microbend losses a 38 cm long preform was fabricated using the one-step high NA germanosilicate core technique. This preform, EMH-20807, having a NA = 0.16, was drawn and coated with four combinations of a relatively hard and soft silicone primary coating and a polyester secondary coating. Table 2.2.4-1 lists the properties of the coating materials employed in this study. The coatings were selected from materials which have been shown to be suitable for optical fiber coating materials. The coating thicknesses were set at 50 to 75 μm for the primary coating and 75 to 100 μm for the secondary coating.

Table 2.2.4-1. Properties of Special Coating Materials.

Coating Type	Coating Material	Durometer Hardness Shore A	Elongation (%)	Tensile Strength (PSI)
Soft Primary	SYLGARD® 184	35	100	900
Hard Primary	GE 670	70	80	1300
Soft Secondary	HYTREL® 40D	--	450	3700
Hard Secondary	HYTREL® 72D	--	350	5700

2.3 Evaluation

Fibers fabricated by the methods described in the preceding sections were evaluated in a variety of ways. For baseline information, the optical attenuation was measured with the fibers in an unstressed condition. The attenuation increase in fibers subjected to bending and microbending stresses was measured. The bending and microbending evaluations were repeated for fibers having four jacket hardness combinations. Finally, the attenuation was measured while a 30 m long fiber was wrapped onto an 8 mm diameter mandrel. These evaluations and the results are discussed in the following sections.

2.3.1 Optical Evaluation

The first step in evaluating fiber performance is the measurement of optical properties. This includes fiber mode content at 6328 Å and fiber attenuation at 0.63, 0.83, and 1.03 μm. Data obtained from these measurements provide baseline comparison between the fibers before performing the bend tests.

The fiber mode content is determined by injecting a five meter section with 6328 Å radiation from a HeNe laser. Mode stripping compound is applied to the bare fiber on a 8.0 cm section near

each end. The far field radiation pattern is observed as the fiber is moved radially across the ~ 0.20 NA injection beam. If the shape of the pattern changes from the nominal gaussian form, indicating the presence of a second mode, the fiber is considered multi-mode and no further evaluation is performed.

Single mode fibers are then tested for attenuation at wavelengths of 0.63, 0.83, and 1.03 μm . Attenuation measurements at three different wavelengths provide additional insight into the fiber transmission properties.

The measurement is performed using the standard attenuation equipment of Figure 2.3.1-1. The system is based on a white light source with optical filters for wavelength selection. A chopper/lock-in amplifier is used to reduce spurious signals and enhance dynamic range. The output optics result in a spot diameter of 220 μm . An injection NA of .243 is used for all single mode fiber measurements.

In order to eliminate spooling effects, particularly on the low NA fibers, the fibers are measured while strung in a relaxed condition. This is achieved by looping the fibers between two 30 cm diameter drums. Each loop is 15 m long. The standard length for loss evaluations is 105 m.

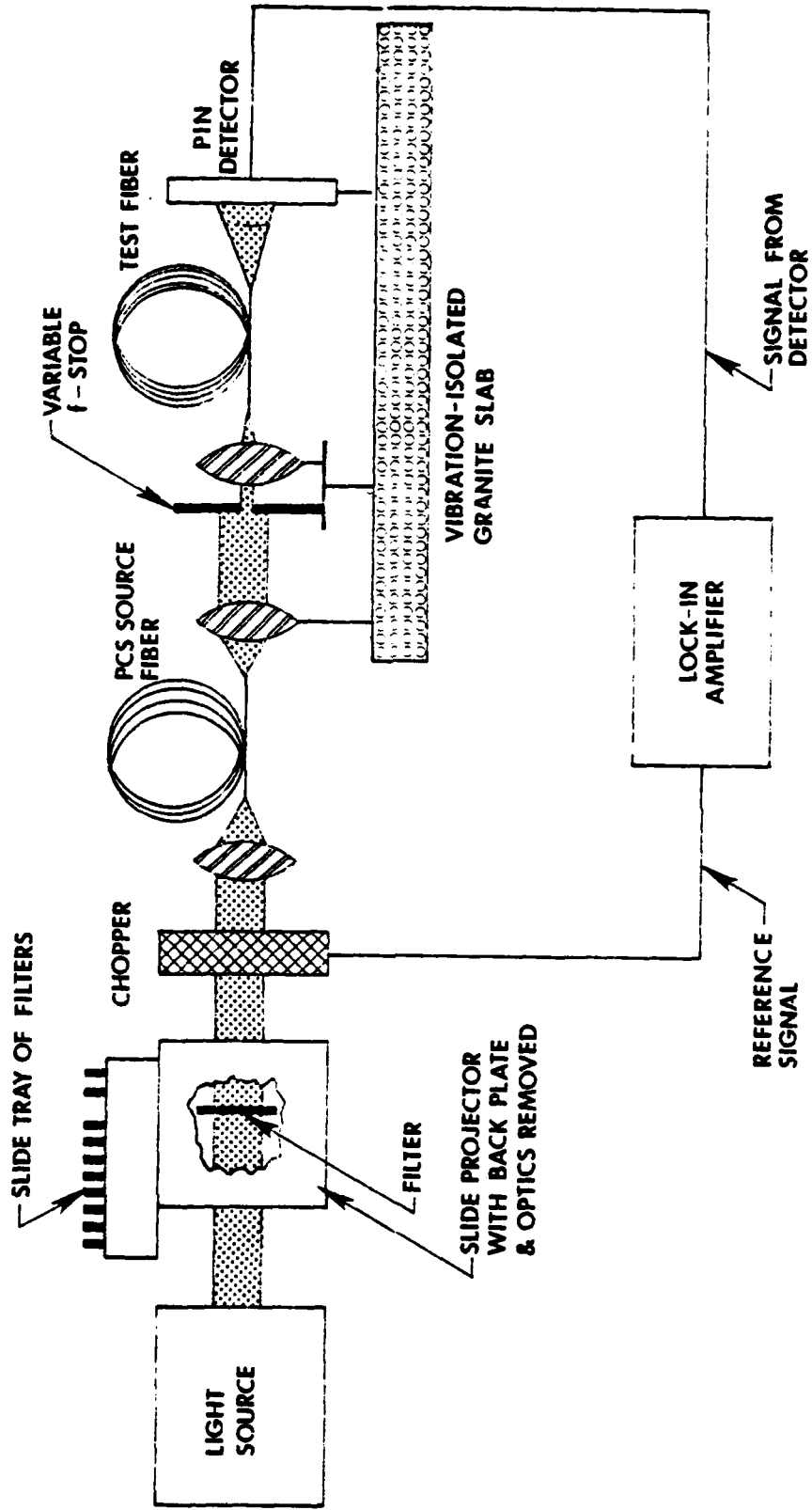

307 10030

Figure 2.3.1-1. Attenuation Measurement Equipment.

After the fiber is strung, the fiber ends are routed to the measurement station. The fiber ends are prepared and the fiber positioned for maximum output with white light injection. Then the filters are placed in the source beam and output voltage readings are recorded for the long length. The fiber is then cut 5 m from the injection end. A new end is prepared and the procedure repeated for the reference length.

The attenuation is calculated per

$$\alpha (.243, \lambda) = \left[\frac{10}{L} \right] \left[\log \frac{V_R}{V_L} \right] \frac{\text{dB}}{\text{km}}$$

where L is the fiber length in kilometers, and V_R and V_L are the output voltages for the reference and long lengths, respectively, at wavelength λ .

The attenuation values of single mode fibers produced under this contract are shown in Table 2.3.1-1.

The lowest unstressed attenuation was found in the 0.11 NA germanosilicate one-step fiber, which is the fiber marketed by ITT as T-110. The two-step fibers had attenuation values which

Table 2.3.1-1. Single Mode Fiber Loss Data.

Preform No	Type	NA	Loss (± 0.3 dB/km)		
			.63 μm	.83 μm	1.03 μm
EMT-20721	1 Step SiO ₂ /GeO ₂ Core	0.11	7.3	2.4	2.4
EMT-20738	1 Step SiO ₂ /P ₂ O ₅ Core	0.11	37.3	17.4	NE
EMH-20495	1 Step SiO ₂ /GeO ₂ Core	0.21	20.2	8.7	5.0
EMH-20627	1 Step SiO ₂ /P ₂ O ₅ Core	0.17	27.7	11.0	35.2
EMT-20710	2 Step SiO ₂ /GeO ₂ Core	0.12	12.4	10.4	NT
EMT-20783	2 Step SiO ₂ /P ₂ O ₅ Core	0.11	12.6	49.8	NT
EMH-20726B	2 Step SiO ₂ /GeO ₂ Core	0.19	68.9	15.3	NT
EMH-20730	2 Step SiO ₂ /P ₂ O ₅ Core	0.19	28.8	152	NT

NE = NOT EVALUATED

NT = NO DETECTABLE TRANSMISSION

were typically higher than the one-step types, especially at the 1.03 μm wavelength. This may be explained by the smaller cladding to core radius ratio for the two-step fibers, which may permit the optical signal to interact with impure substrate glass as the mode diameter becomes large at long wavelengths. Additionally, it can be seen that the high NA fibers typically have baseline attenuation values higher than those for the low NA fibers. This relationship was also noted in the results for Contract N00173-78-C-0196 for High NA Single Mode Fiber Development.

2.3.2 Bending Loss Evaluation

Tests were performed to determine the effects of fiber design and fabrication variations on fiber transmission while under bending stress.

The equipment shown in Figure 2.3.2-1 was used. The equipment uses two lock-in amplifiers to provide stable, low noise detection of both input and output power levels. The ability to actively monitor the input power greatly improves the test accuracy. Input levels may fluctuate because of positioner movement or other causes. The variation is recorded by the monitoring coupler channel. This isolates output power variations

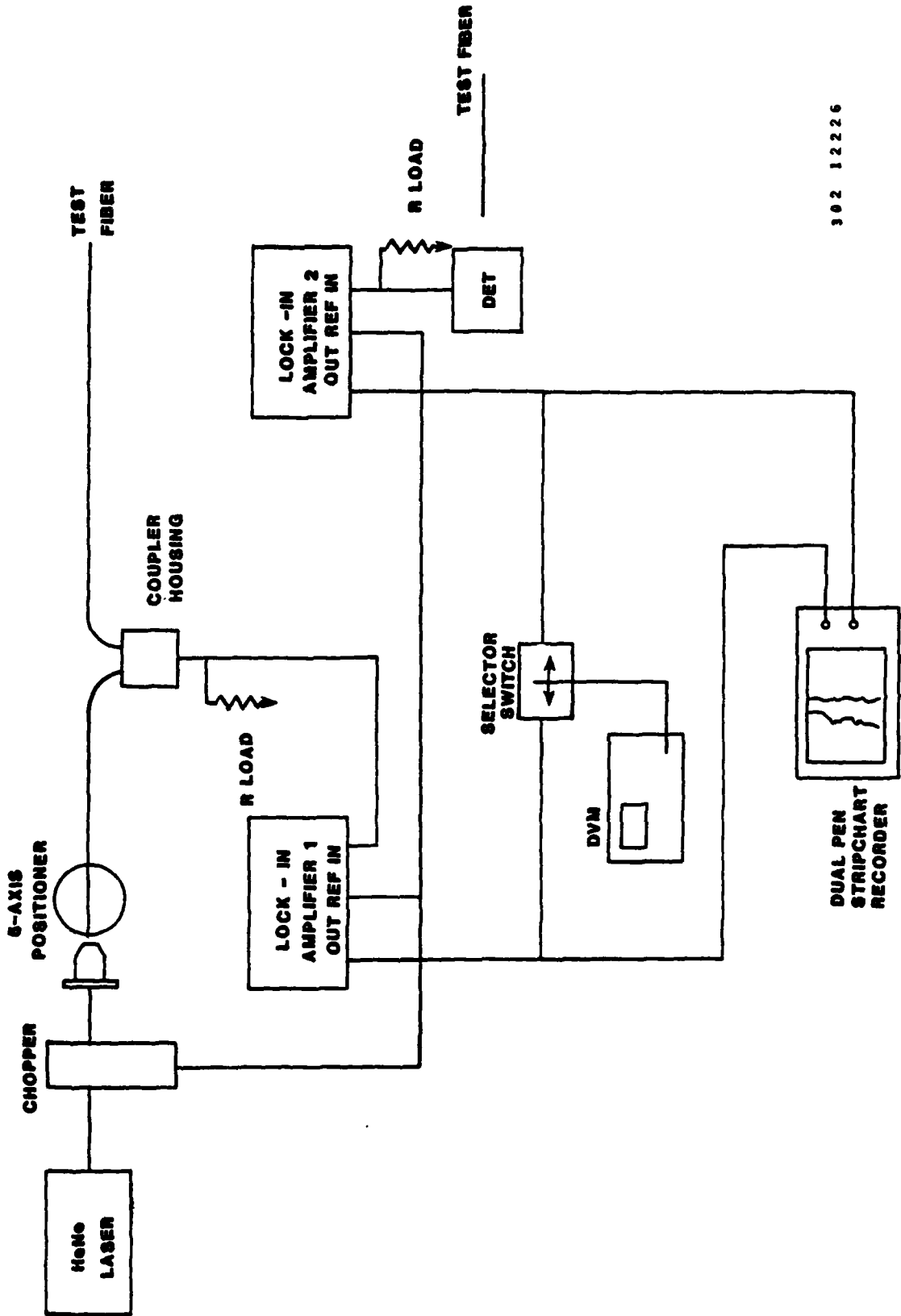

302 12226

Figure 2.3.2-1. Excess Loss Measurement Equipment.

caused by applied stress from those caused by input power variations. In addition to improving accuracy, the coupler also reduces test time by eliminating the need for cutting reference lengths for each measurement.

The coupler, developed for this contract, is shown in Figure 2.3.2-2. The completed coupler is positioned in the housing of Figure 2.3.2-3. The housing detector collects the radiation emitted from the fiber, providing an input signal to the lock-in amplifier.

To perform a bending loss measurement, a 210 m length of the test fiber is strung. Both fiber ends are routed to the test area and ~30 m of one end stored on a 30 cm diameter drum.

Both fiber ends are prepared and the fiber injected for maximum output. The output load resistor is selected for the maximum signal possible without saturating the detector.

With the fiber injected, the coupler is fabricated. The data sheet of Figure 2.3.2-4 is used to document coupler fabrication and performance.

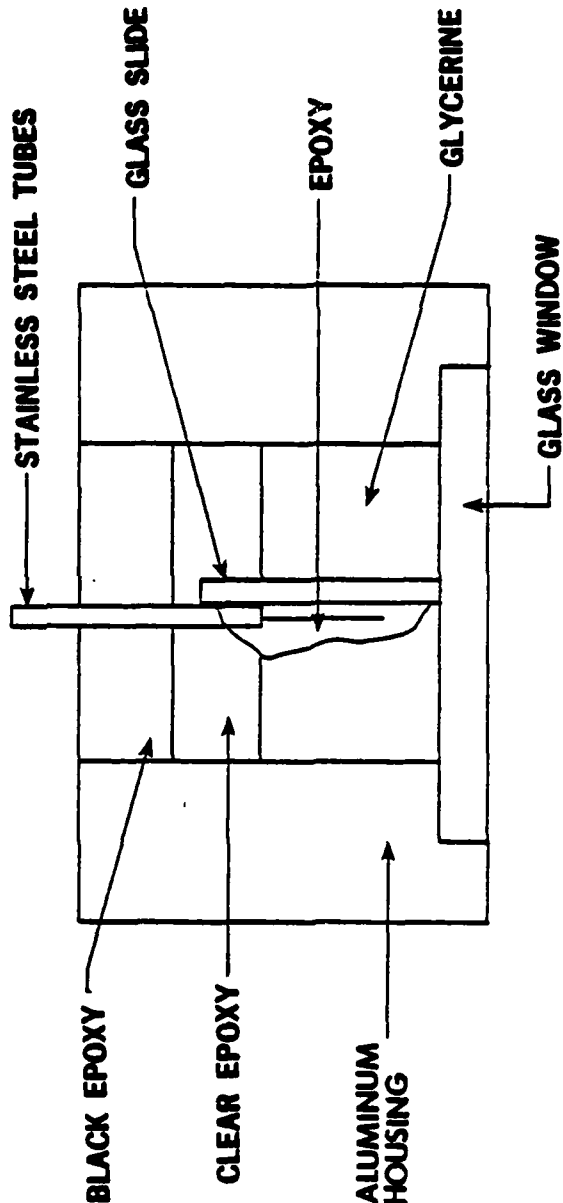
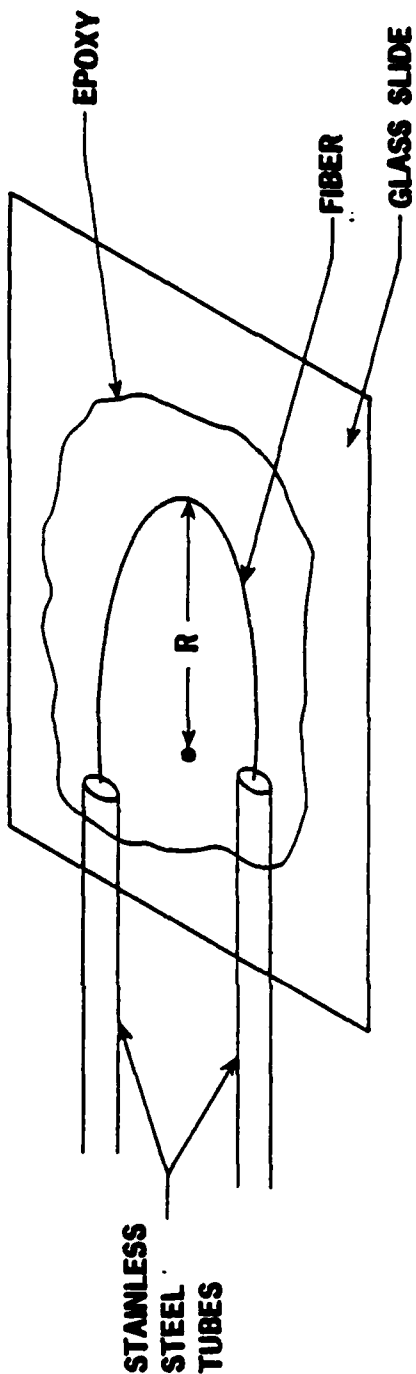

302 11701

Figure 2.3.2-2. Monitoring Coupler.

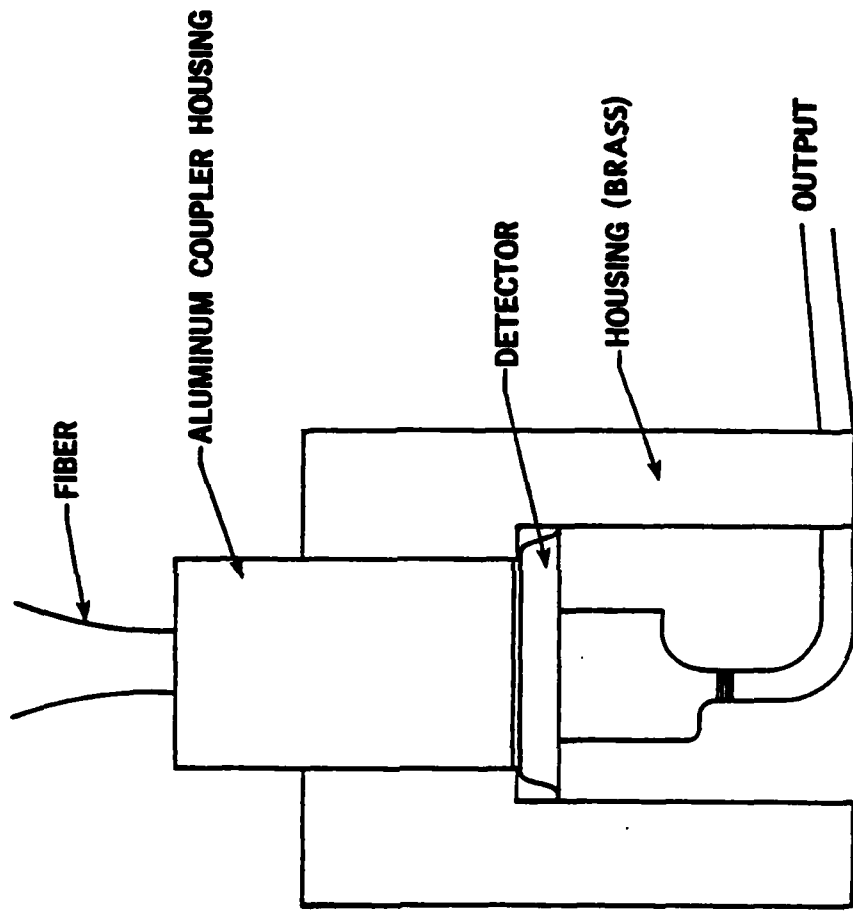

302 11752

Figure 2.3.2-3. Monitoring Coupler Housing.

Preform:

CNR Single Mode Fiber Data Sheet 1

Date Begun _____ Date Finished _____

TEST FIBER CHARACTERISTICS

Fiber Ident _____	Fiber NA _____
Attenuation (.243NA) .63um _____ dB/km	_____ dB/km
_____ .83um _____ dB/km	_____ dB/km
_____ 1.03um _____ dB/km	
Fiber C. D. _____ um	Test Length _____ m

COUPLER DATA: ($\lambda = 6328\text{\AA}$) Analyst _____
 Time Req. _____ hrs.

Original Throughput Power V_{thro} _____ V_{dc} _____ Scale

Tap Radius _____ mm
 V_{thr} ($R_o =$ _____) _____ V_{dc} _____ Scale
 V_{tap} ($R_t =$ _____) _____ V_{dc} _____ Scale

Coupling Ratio-CR $\frac{V_{tap}}{V_{thr}}$ _____

Throughput Ratio-TR $\frac{V_{thr}}{V_{thro}}$ _____

Stability Test $R_o =$ _____ $R_t =$ _____

Case 1 (Max. V_{thr})	V_{thr} _____ V_{dc} _____ Scale
	V_{tap} _____ V_{dc} _____ Scale
	$CR_1 =$ _____
Case 2 ($\approx 50\%$ Max. V_{thr})	V_{thr} _____ V_{dc} _____ Scale
	V_{tap} _____ V_{dc} _____ Scale
	$CR_2 =$ _____
Case 3 ($\approx 10\%$ Max. V_{thr})	V_{thr} _____ V_{dc} _____ Scale
	V_{tap} _____ V_{dc} _____ Scale
	$CR_3 =$ _____

Figure 2.3.2-4. Coupler Performance Data Sheet.

A load resistor, selected for maximum allowable signal level, is added to the housing detector output. The injection level is then varied to determine coupler stability with varying injected power levels.

The data sheet of Figure 2.3.2-5 is used to record bend loss data. Two sections are tested from each test fiber.

Bending stress is applied with the fixture shown in Figure 2.3.2-6. Four interchangeable aluminum mandrels having diameters of 12.7, 9.5, 6.4 and 3.2 mm are used in the fixture. A 7.6 cm diameter pulley blank is mounted on each mandrel to hold the fiber with a controlled radius.

Initial measurements are made with the fiber loosely coiled. The minimum bend radius in this condition is approximately 2 cm for 90° duration.

Following the initial measurement, the fiber is placed on the central positioning fixture and input and output levels are recorded. Tension controlling weights are then secured to each side of the fiber and the measurement is repeated. A load of 10 g was selected to maintain the proper fiber tension.

ONR Single Mode Fiber Data Sheet 2

Preform:

Bending Data 36033011

Fiber Ident _____
Analyst _____

Fiber NA _____
Time Req. _____ hrs.

Test Section 1 2

Date Performed _____

Strip Chart used? Yes No

Initial Test Sample Length. _____ m

$\lambda = 6328\text{\AA}$

$R_c =$ _____

MANDREL DIAMETER	MANDREL TURNS	FIBER TURNS	VOUT		10 dB	Condition
			V _{dc}	SCALE		
Loose	None	N/A			0.0	A
	On Curl Fixtr.	N/A				B
	With Weights	N/A				C
<input type="checkbox"/> 12.7mm or <input type="checkbox"/> _____mm	0.5	1.0				D
	1.0	2.0				E
	2.5	5.0				F
	5.0	10.0				G
	10.0	20.0				H
<input type="checkbox"/> 9.5mm or <input type="checkbox"/> _____mm	0.5	1.0				D
	1.0	2.0				E
	2.5	5.0				F
	5.0	10.0				G
	10.0	20.0				H
<input type="checkbox"/> 6.4mm or <input type="checkbox"/> _____mm	0.5	1.0				D
	1.0	2.0				E
	2.5	5.0				F
	5.0	10.0				G
	10.0	20.0				H
<input type="checkbox"/> 3.2mm or <input type="checkbox"/> _____mm	0.5	1.0				D
	1.0	2.0				E
	2.5	5.0				F
	5.0	10.0				G
	10.0	20.0				H
Loose	With weights	N/A				C

Figure 2.3.2-5. Bend Loss Evaluation Data Sheet.

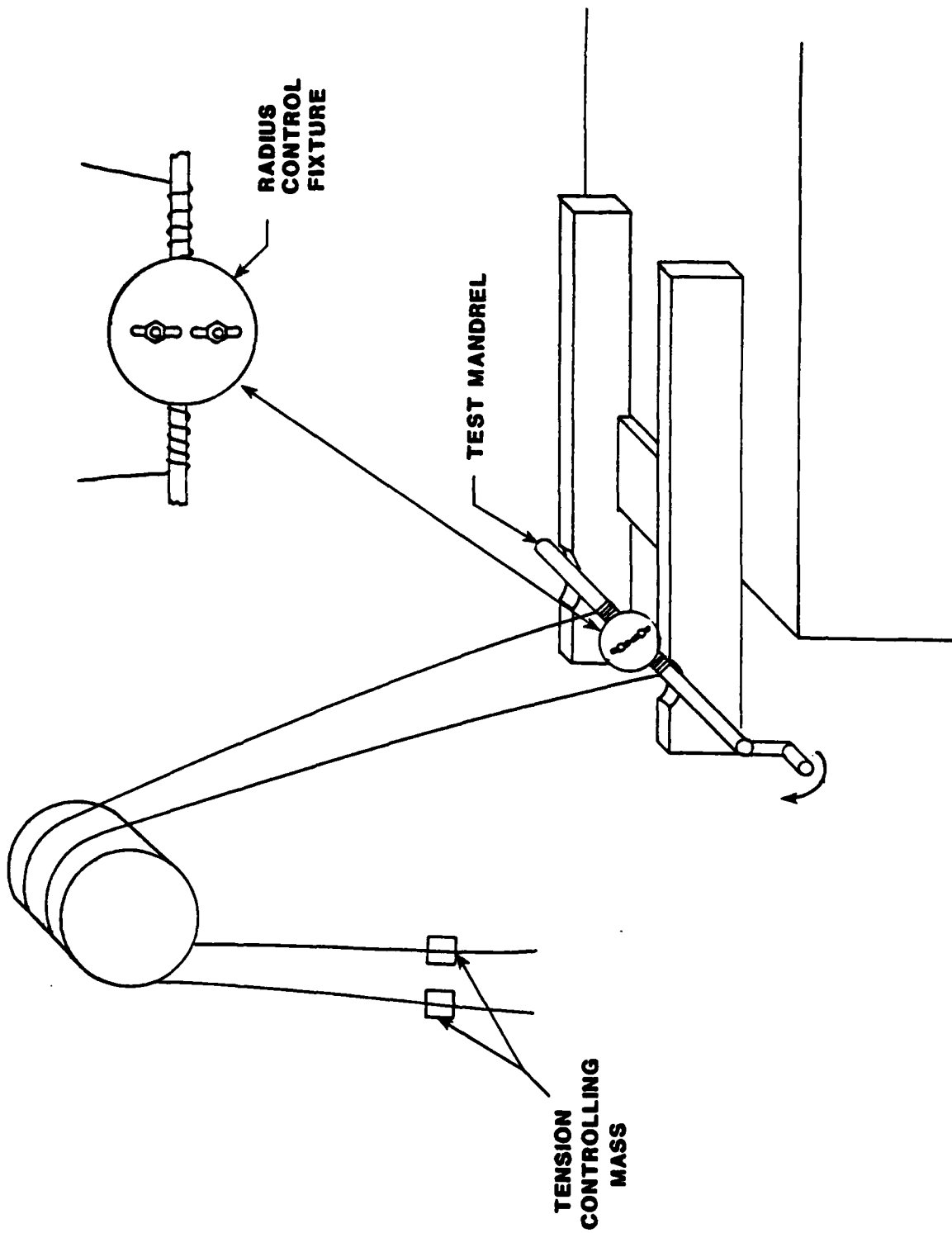

Figure 2.3.2-6. Single Mode Fiber Bending Loss Test Apparatus.

302 12230

Loss measurements are taken with 1, 2, 5, 10 and 20 fiber turns on each mandrel proceeding from largest to smallest. Following the last measurement, the fiber is removed from the mandrel. Then the excess loss is measured in the radius control fixture under tension to determine any permanent effects.

The test section is then removed and the test repeated on the second fiber section.

The data obtained for the eight test fibers is shown in Figures 2.3.2-7 through 2.3.2-14. Excess loss is plotted as a function of number of turns for each mandrel size. Since the results of the first and second tests agree closely, only the results of the first test are presented in this section. Results of the second test for each fiber may be found in Appendix A.

With the exception of EMT-20783 which was the 2-step low NA phosphosilicate core fiber, all fibers showed a very small bend-induced loss through 20 turns on the 12.7 mm mandrel. With 20 turns on the 9.5 mm mandrel the low NA fibers began to exhibit excess losses ranging from 3 to 25 dB, while the high NA fiber

1 STEP, LO NA, GE02 CORE: TEST 1

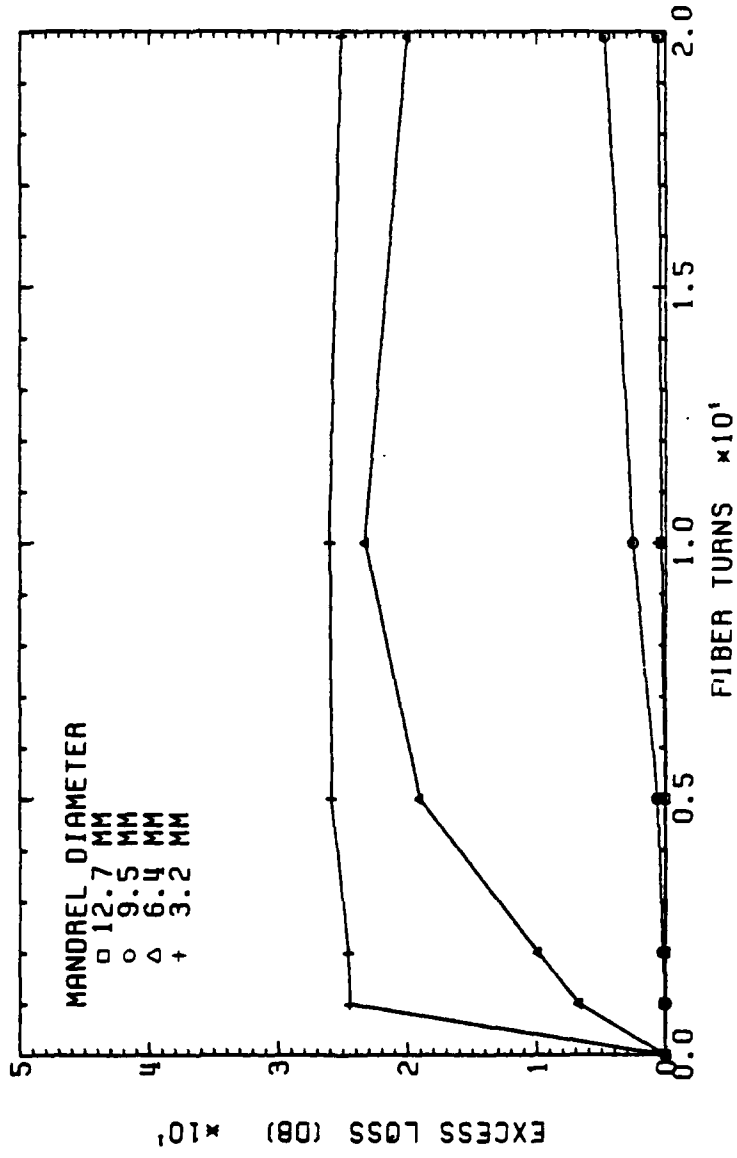

Figure 2.3.2-7. Bend Loss Test Results for EMT-20721.

1 STEP, LO NA, P205 CORE: TEST 1

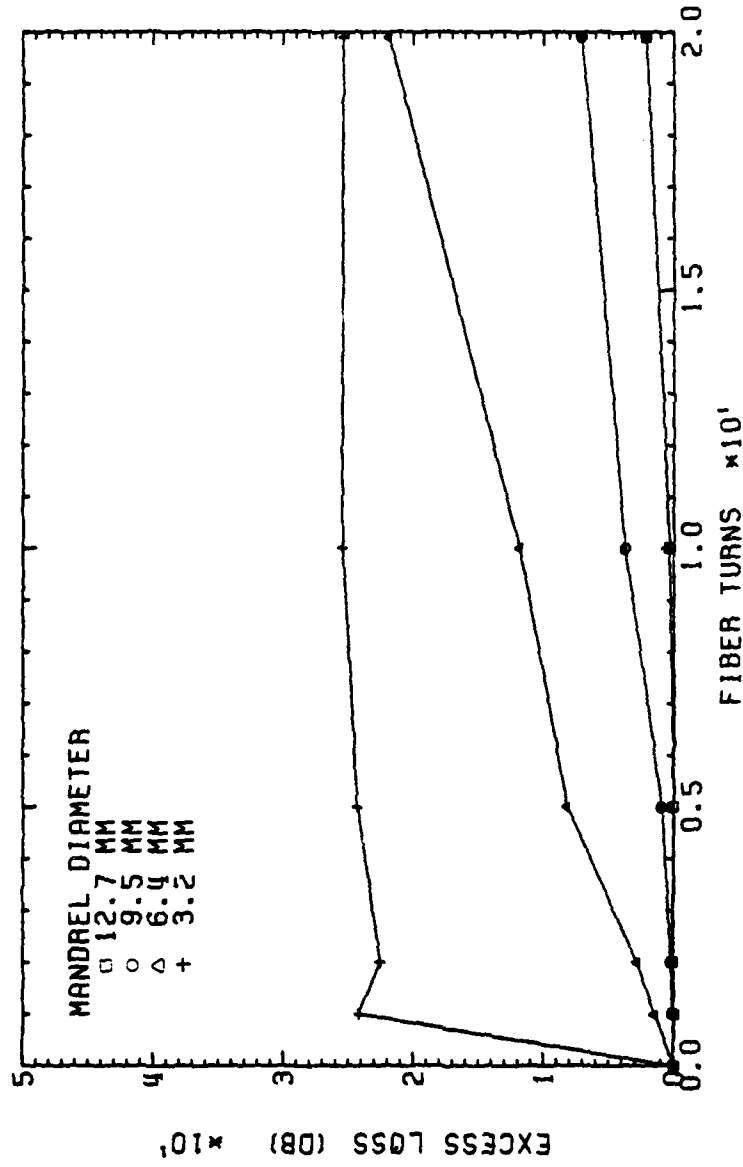

Figure 2.3.2-8. Bend Loss Test Results for EMT-20738.

1 STEP, HI NA, GE02 CORE:TEST 1

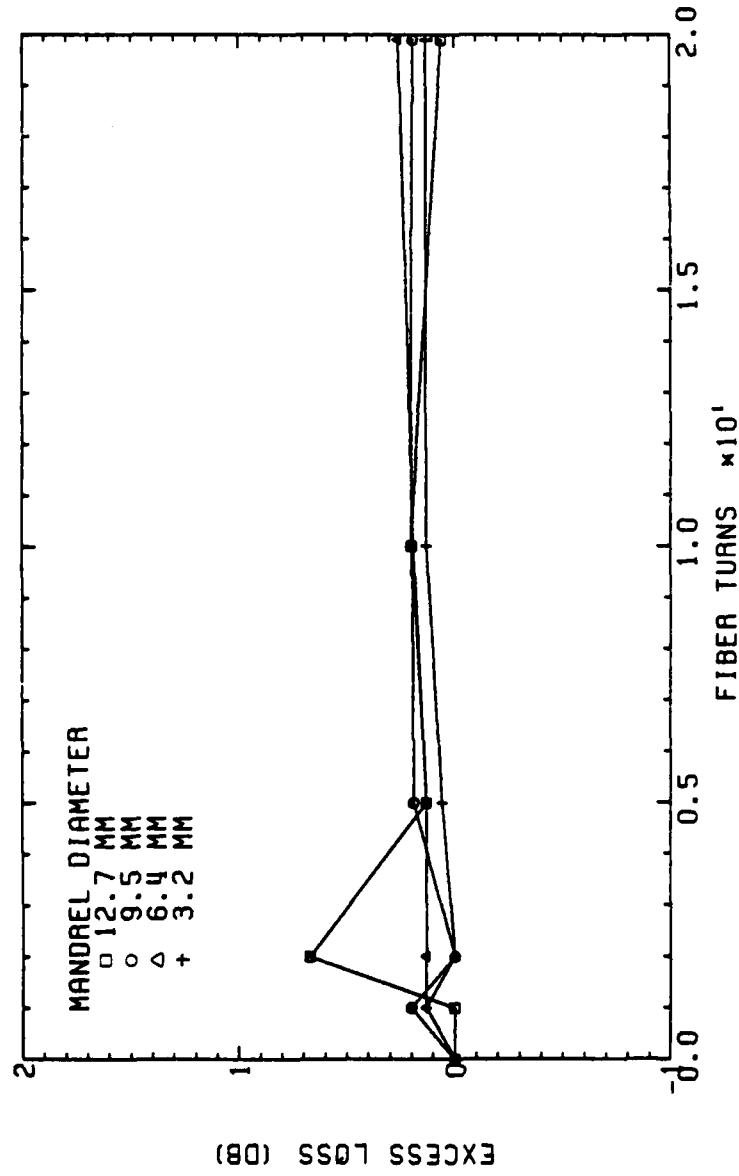

Figure 2.3.2-9. Bend Loss Test Results for EM-20495.

1 STEP, HI NA, P205 CORE: TEST 1

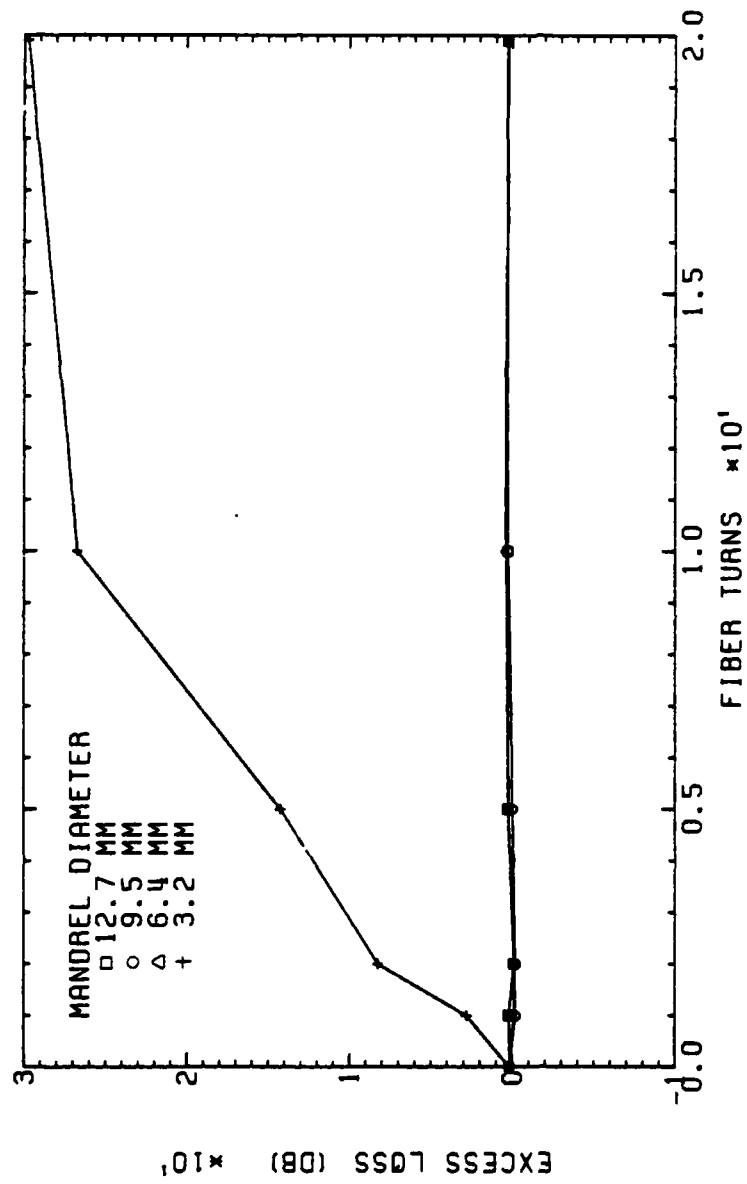

Figure 2.3.2-10. Bend Loss Test Results for EMH-20627.

2 STEP, LO NA, GE02 CORE: TEST 1

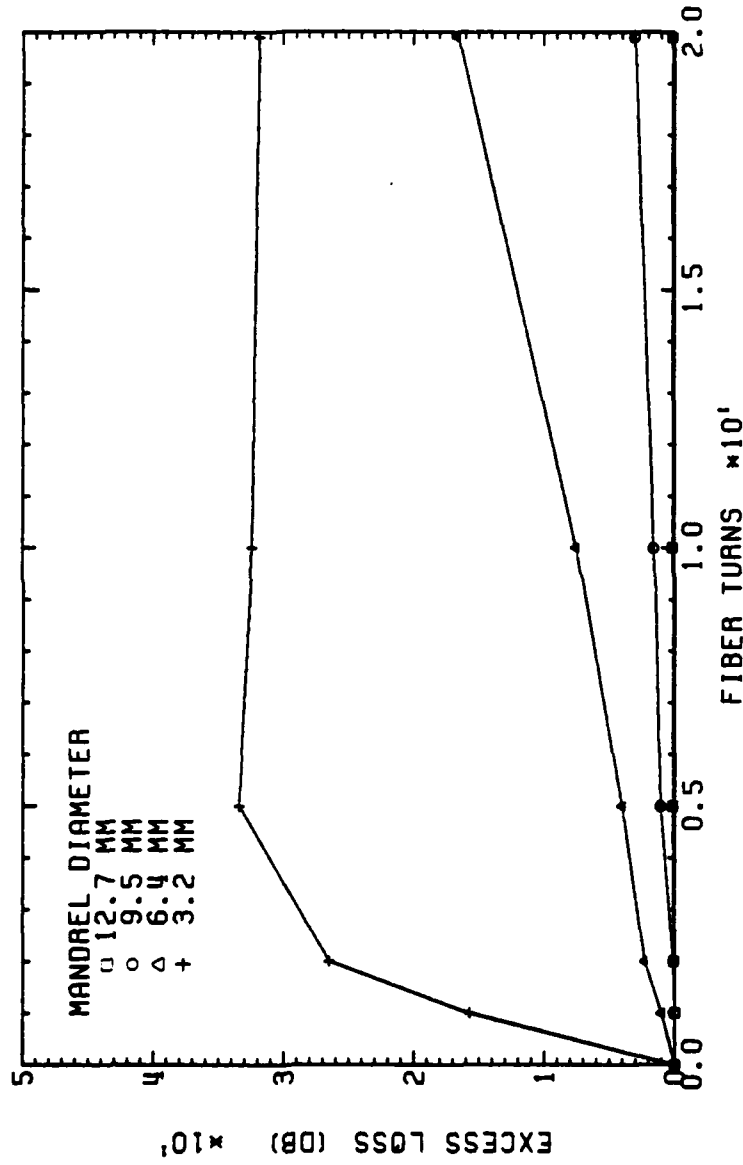

Figure 2.3.2-11. Bend Loss Test Results for EMT-20710A.

2 STEP, LO NA, P205 CORE: TEST 1

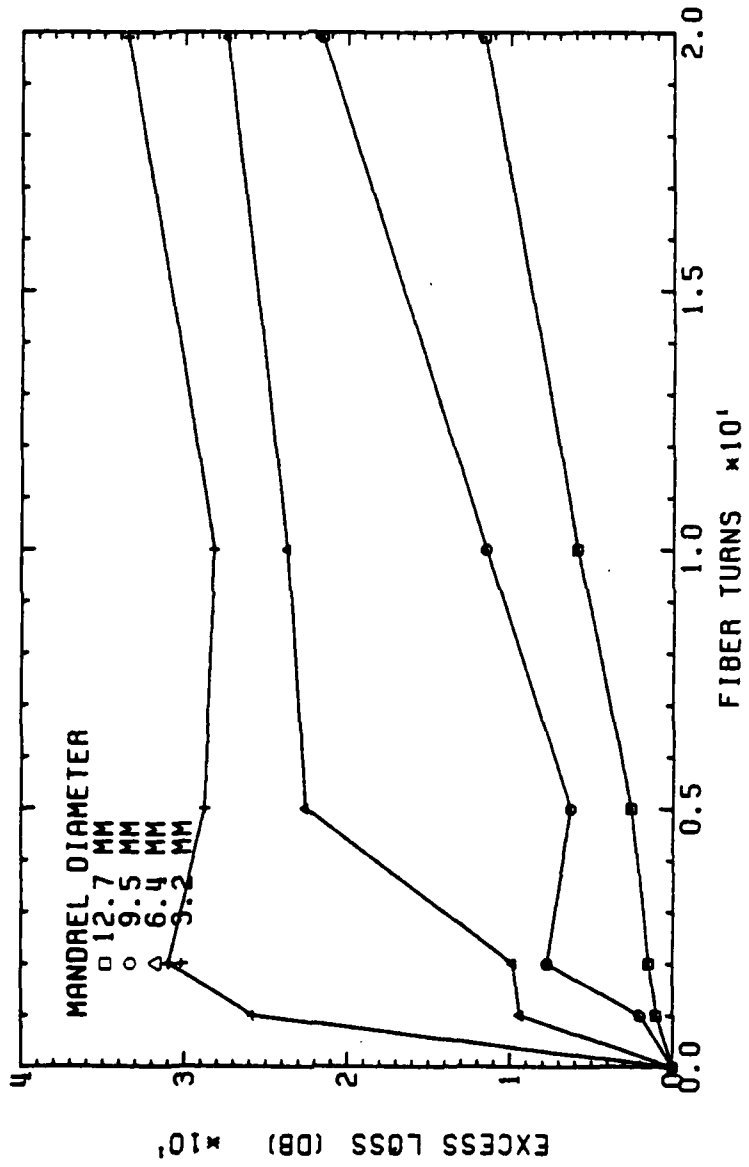

Figure 2.3.2-12. Bend Loss Test Results for EMT-20783.

2 STEP, HI NA, GE02 CORE: TEST 1

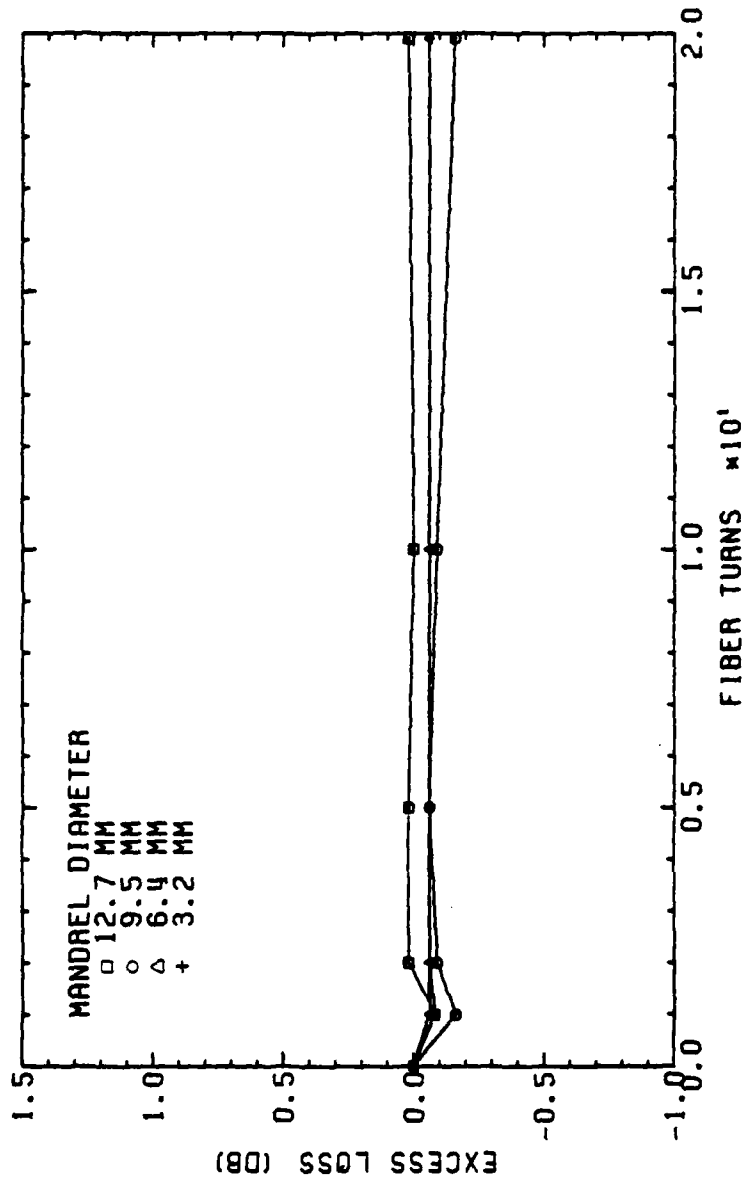

Figure 2.3.2-13. Bend Loss Test Results for EMH-20726B.

2 STEP, HI NA, P205 CORE: TEST 1

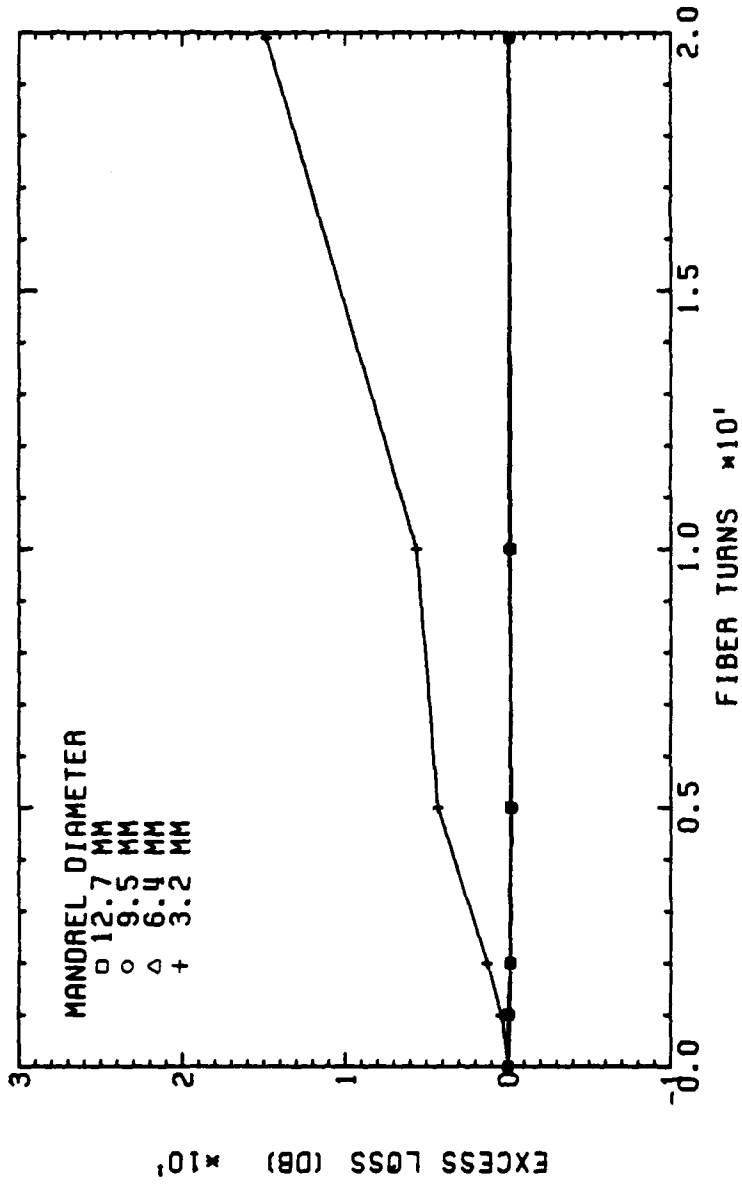

Figure 2.3.2-14. Bend Loss Test Results for EMH-20730.

losses ranged from 0.0 to 0.2 dB. When 20 turns were wound onto the 6.4 mm mandrel, the low NA fiber losses ranged from 16 to 28 dB while losses for the high NA fibers ranged from 0.0 to 0.26 dB. When wound onto the 3.2 mm mandrel the 1- and 2-step high NA phosphosilicate core fibers exhibited losses of 30 dB and 15 dB respectively after 20 turns while the high NA germanosilicate core fibers showed unmeasurable loss increases. In contrast, the low NA fibers all showed induced losses greater than 25 dB after 20 turns on the 3.2 mm mandrel, with both of the 1-step fibers measuring >25 dB and both 2-step fibers measuring slightly more than 32 dB. These results are summarized in Figure 2.3.2-15 for the 6.4 mm mandrel and in Figure 2.3.2-16 for the 3.2 mm mandrel.

To explain the increase in bending loss for the 0.17 NA phosphosilicate core fiber in comparison to the 0.11 NA fiber, the fiber optical and mechanical properties were reviewed. No unusual dimensional or attenuation values were discerned. An examination of the bending loss variations as a function of turns for the 0.11 and 0.17 NA fibers (Figures 2.3.2-8 and 2.3.2-10) shows the 0.11 NA fiber to approach its maximum bending loss after one turn, after which only a small change occurs. In contrast, the 0.17 NA fiber is not affected as much by the first turns but exhibits a more linear loss increase with increasing number of bends.

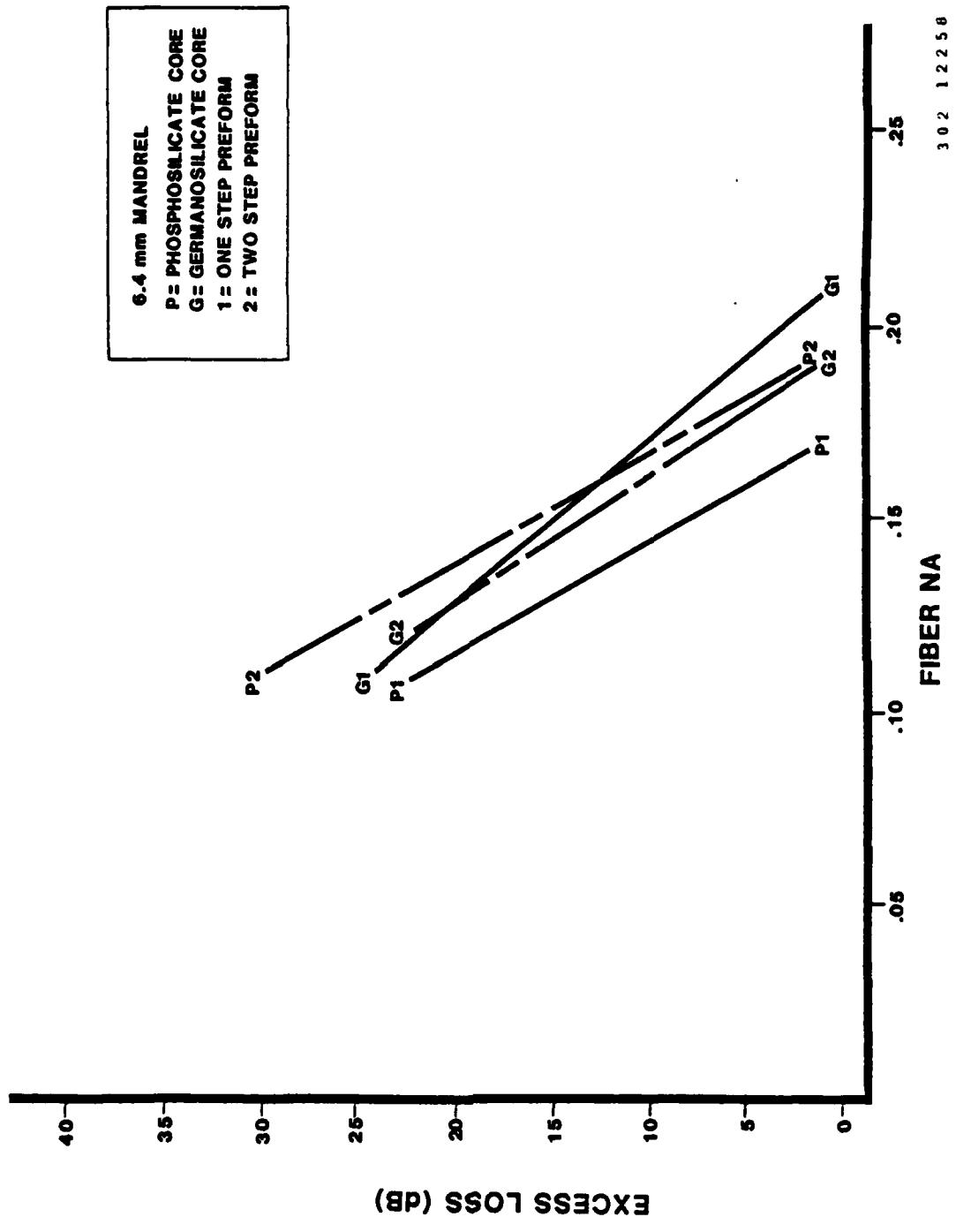
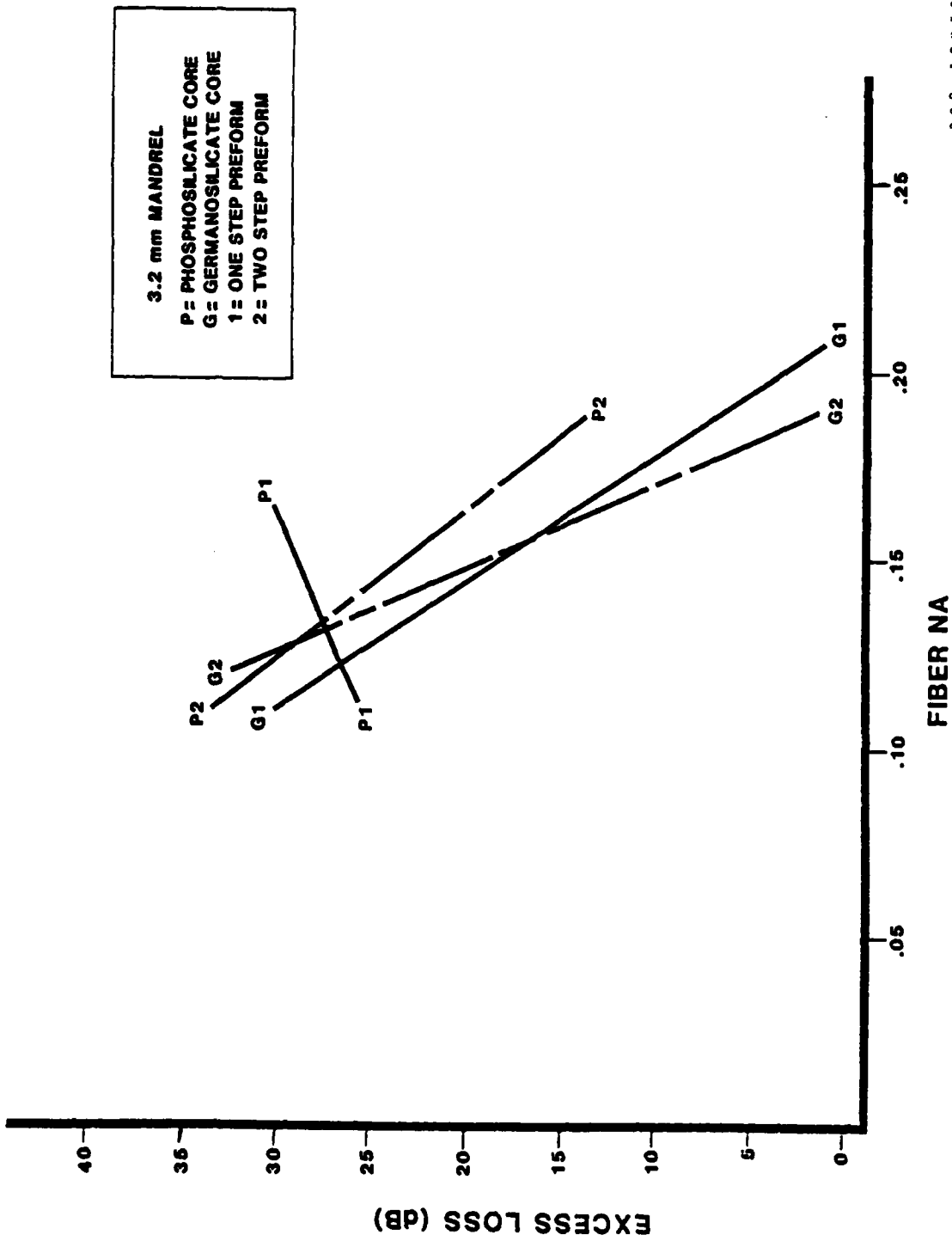

Figure 2.3.2-15. Bend Loss Test Results Summary:
 20 Turns, 6.4 mm Mandrel.



302 12259

Figure 2.3.2-16. Bend Loss Test Results Summary:
 20 Turns, 3.2 mm Mandrel.

2.3.3 Microbending Loss Evaluation

In addition to the bending stress created in packaging single mode fibers, increased transmission loss could result from microbending. Microbending is caused by small deflections in the fiber axis due to factors such as winding crossovers under high tension, mandrel surface roughness, and jacket imperfections, among others.

Experiments conducted to determine the best means of simulating microbend conditions resulted in the fixture shown in Figure 2.3.3-1.

The fixture consists of two aluminum plates, 30.0 x 30.0 x 2.5 cm, placed one above the other. The inner surface of each plate contains 46 to 48 250 μ m diameter wire segments spaced at 6.3 mm intervals. The two groups of wire strands are offset approximately by 3.1 mm to facilitate bending. The strands are held in place by a cyanoacrylate adhesive.

To simulate microbending conditions, the fixture is positioned so that multiple loops of strung fibers pass between the plates. The plates are brought together, applying the microbending stress, and the effect on fiber transmission measured.

Roanoke, Virginia

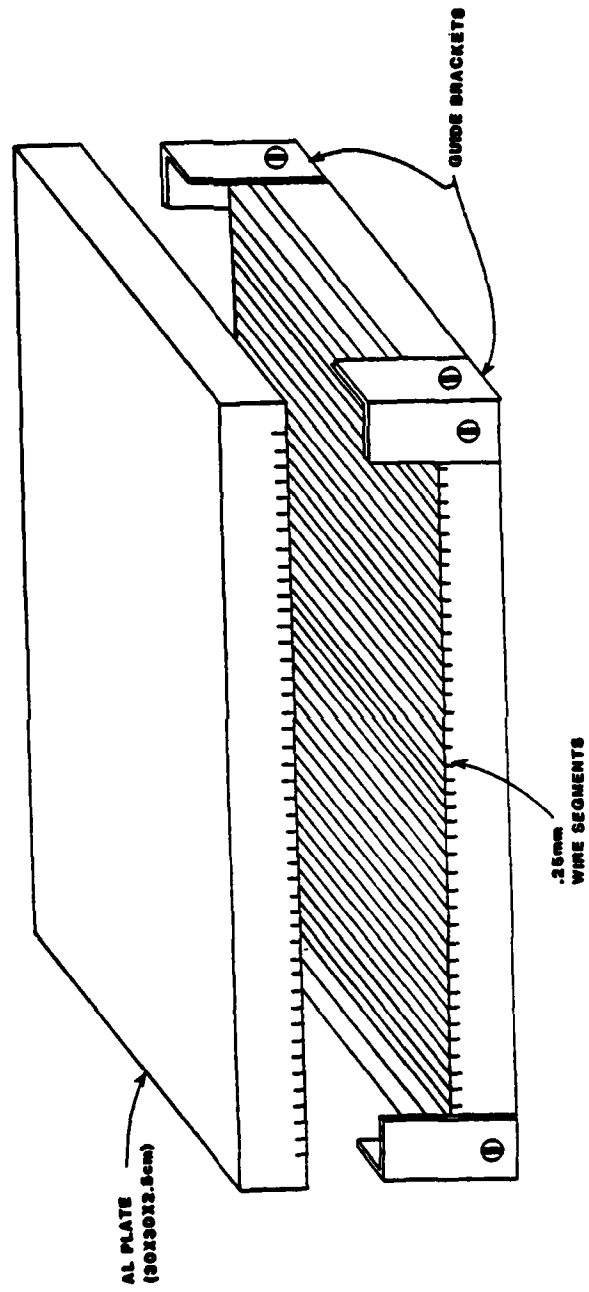

902 11916

Figure 2.3.3-1. Single Mode Fiber Microbend Loss Test Apparatus.

Initial experiments with high NA fibers indicated that a loading mass beyond the 6.7 kg of the upper plate was required to create an appreciable effect. A mass of 9.4 kg was added in the form of four steel cylinders.

Microbending tests were performed on the strung fiber following the second bend loss test. The loss monitoring equipment is the same used for the bending tests, as shown in Figure 2.3.2-1. Twelve positions were marked along the approximately seven meters between the two drums. Loss is monitored as the fixture, with loading mass, is applied at the twelve positions in both the upper and lower fiber loops. Excess loss was measured at each position and the data were recorded on the data sheet shown in Figure 2.3.3-2.

The results obtained for each of the eight test fibers are shown in Figures 2.3.3-3 through 2.3.3-10. A summary of the test results appears in Table 2.3.3-1, where the mean loss and standard deviation of the 24 measurements are reported for each fiber. The data shows the high NA fibers to have negligible microbending losses. The low NA fibers exhibit losses ranging from 4.3 dB to 49 dB except for the two step germanosilicate fiber which showed a mean induced loss of 0.2 dB.

ONR Single Mode Fiber Data Sheet 3

Preform: _____

Microbending Data 36033011

Fiber Ident _____
 Analyst _____

Fiber NA _____
 Time Req. _____ hrs.

Strip Chart Used? Yes No

Test Sample Length _____ m

$\lambda = 6328\text{\AA}$

Strung Length _____ m

Date Performed _____

$R_o =$ _____

$R_t =$ _____

LOAD MASS kg	POSITION	VCUT	SCALE	v_{cap}	SCALE	$\Delta\alpha$ dB
w/o fixture	N/A					0.0
	Upper	1				
	2					
	3					
	4					
	5					
	6					
	7					
	8					
	9					
	10					
	11					
	12					
w/o fixture	N/A					
	Lower	1				
	2					
	3					
	4					
	5					
	6					
	7					
	8					
	9					
	10					
	11					
	12					
w/o fixture	N/A					

Figure 2.3.3-2. Microbend Loss Data Sheet.

EMT-20721: 1 STEP, LO NA, GE02 CORE

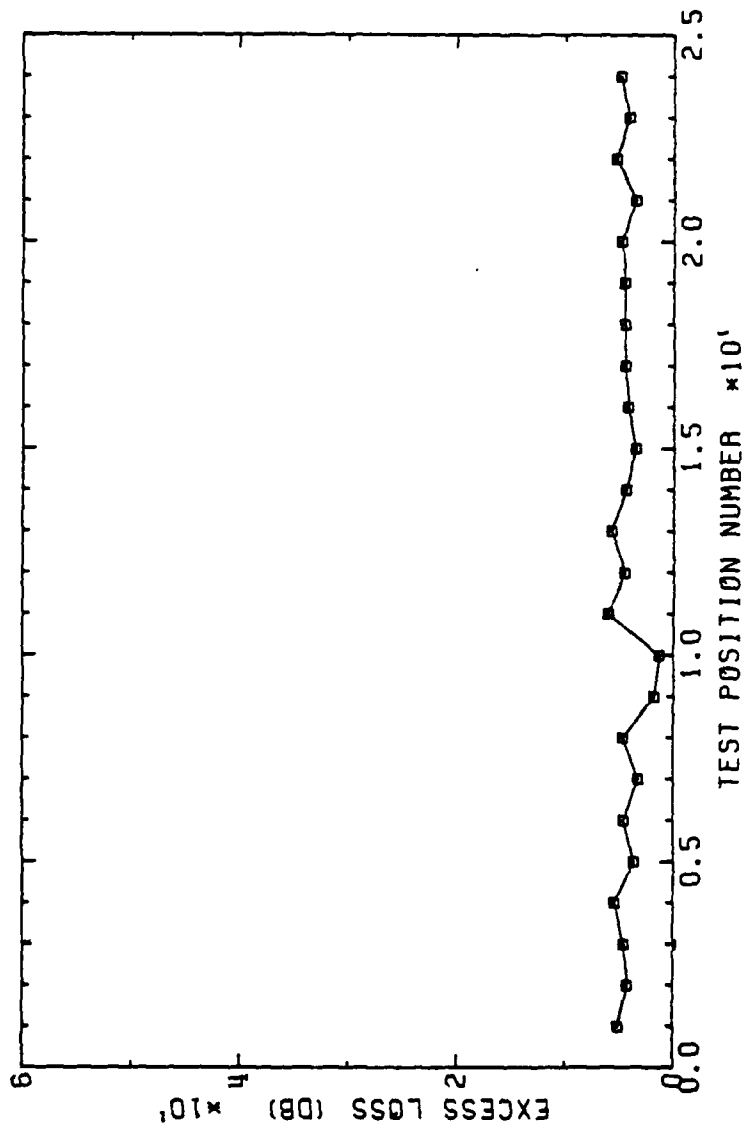

Figure 2.3.3-3. Microbend Loss Test Results for EMT-20721.

EMT-20738: 1 STEP, LO NA, P205 CORE

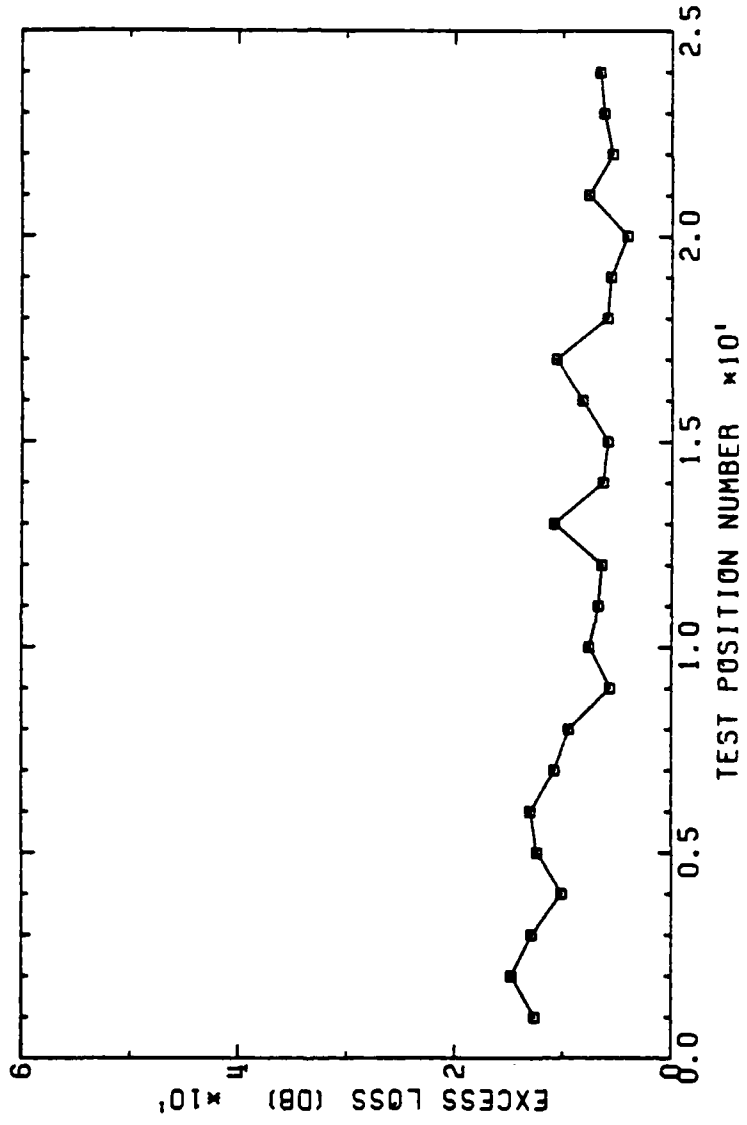

Figure 2.3.3-4. Microbend Loss Test Results for EMT-20738.

EMT-20710A: 2 STEP, LO NA, GE02 CORE

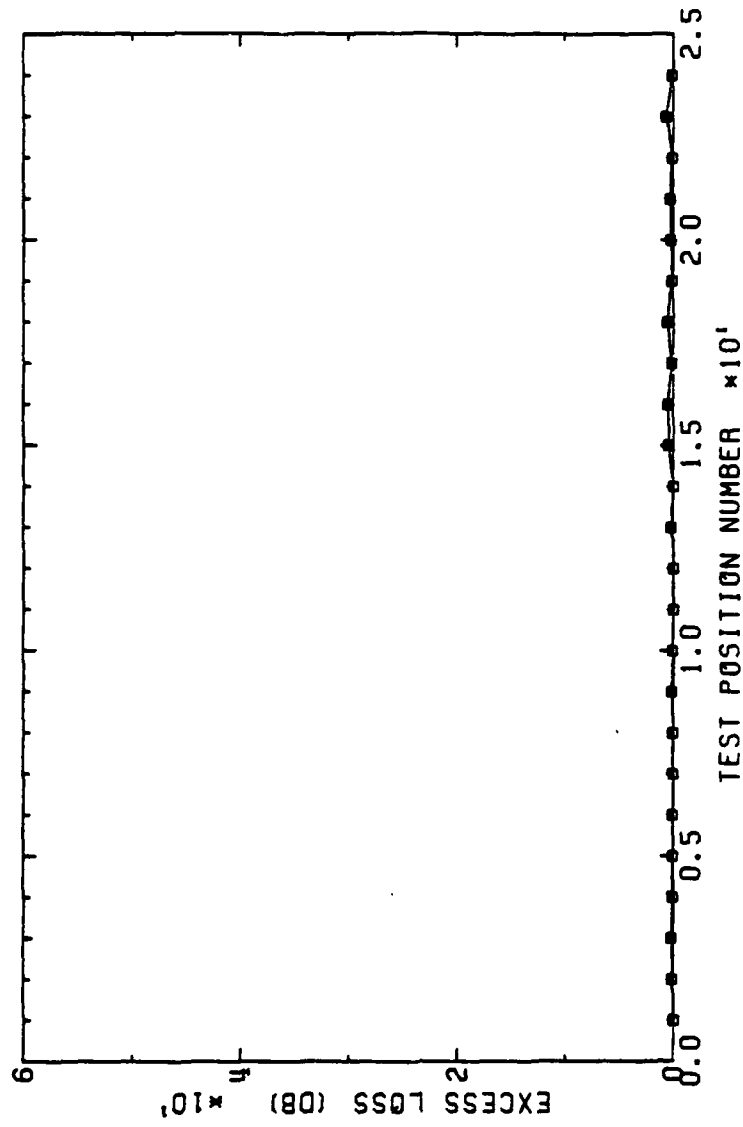

Figure 2.3.3-5. Microbend Loss Test Results for EMT-20710A.

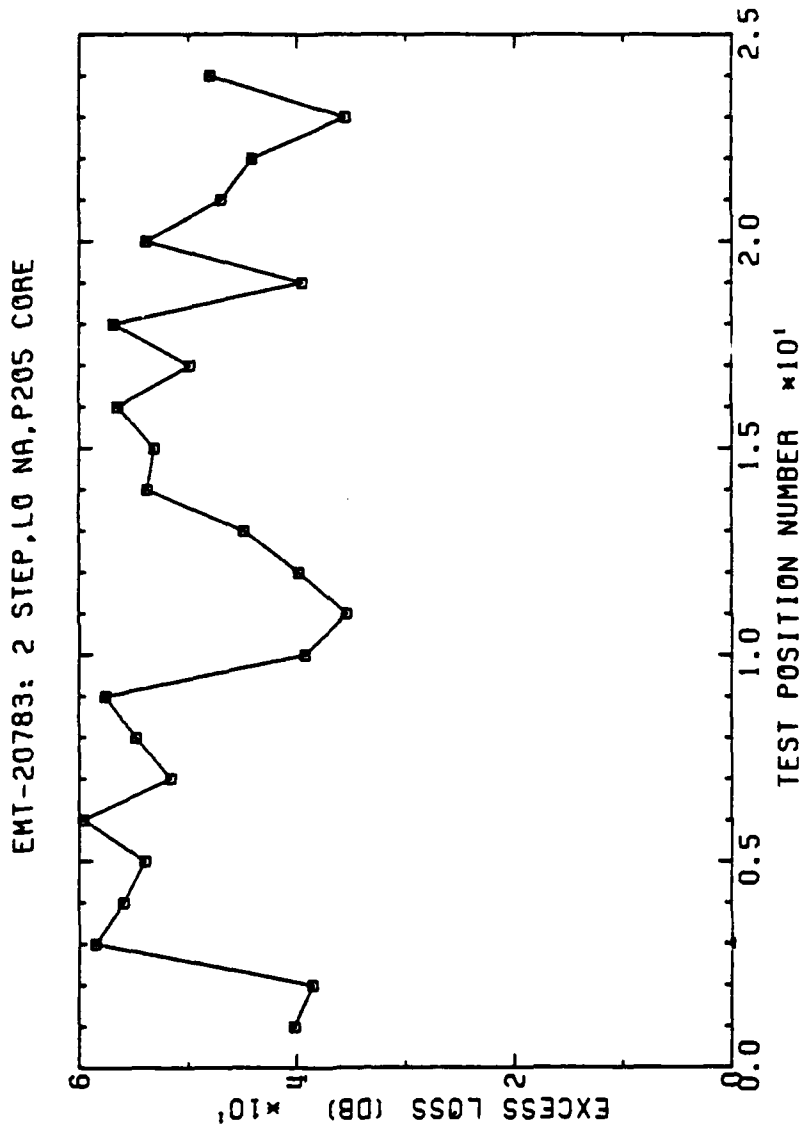

Figure 2.3.3-6. Microbend Loss Test Results for EMT-20783.

EM-20495: 1 STEP, HI NA, GE02 CORE

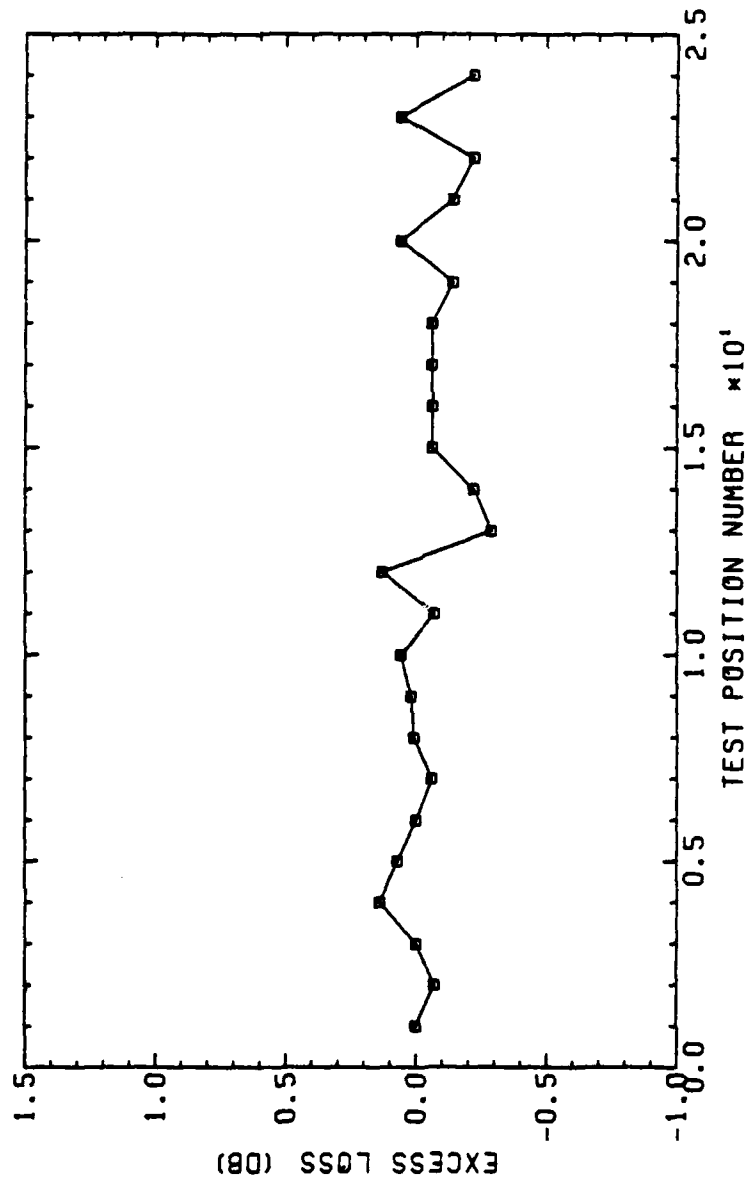

Figure 2.3.3-7. Microbend Loss Test Results for EM-20495.

1 STEP, HI NA, P205 CORE

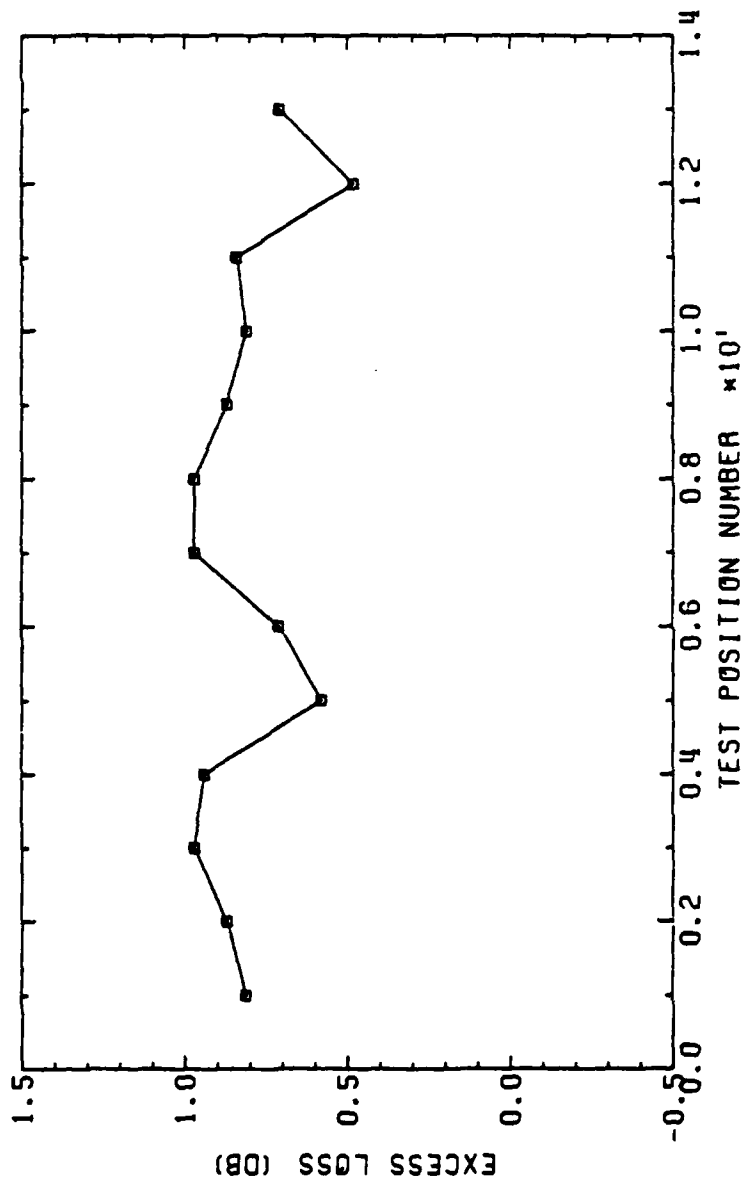

Figure 2.3.3-8. Microbend Loss Test Results for EMH-20627.

2 STEP, HI NA, GE02 CORE

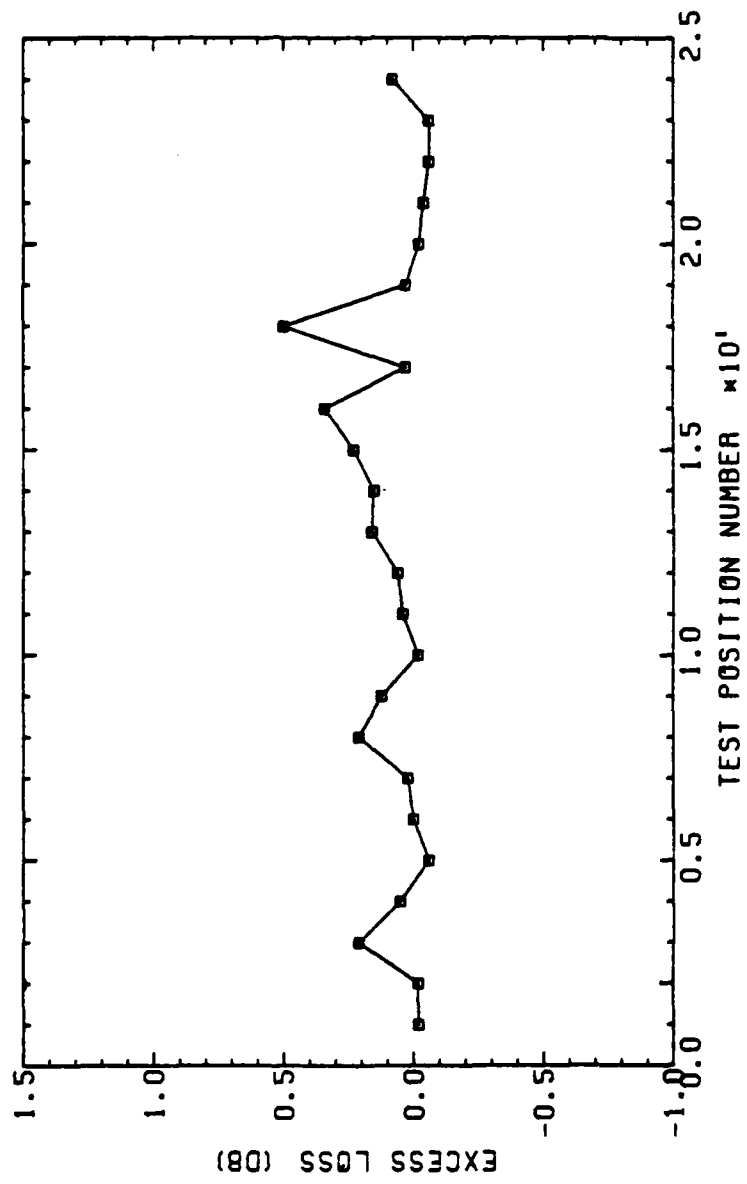

Figure 2.3.3-9. Microbend Loss Test Results for EMH-20726B.

2 STEP, HI NA, P205 CORE

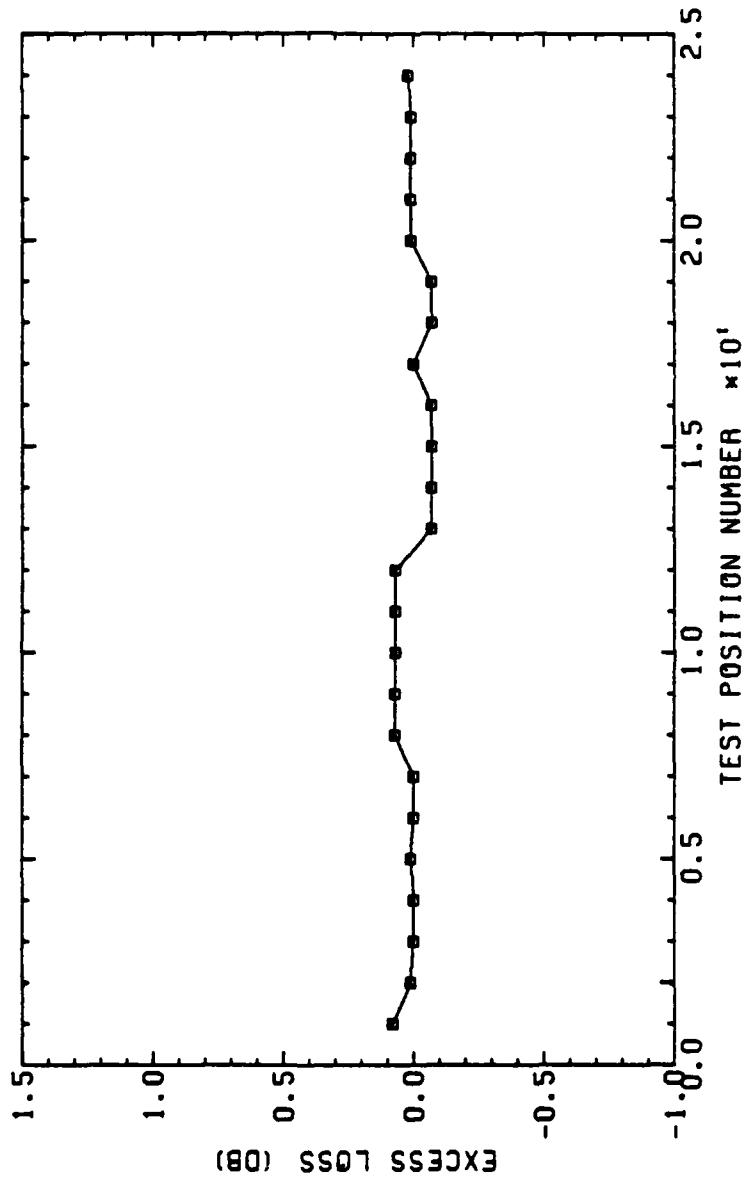

Figure 2.3.3-10. Microbend Loss Test Results for EMH-20730.

Table 2.3.3-1. Microbend Loss Test Result Summary.

<u>Fiber Number</u>	<u>Preform Type</u>	<u>Core Dopant</u>	<u>NA</u>	<u>Excess Loss (dB)</u>	
				<u>Mean</u>	<u>Std. Dev.</u>
EMT-20721	1 Step	GeO ₂	.11	4.3	1.9
EMT-20738	1 Step	P ₂ O ₅	.11	8.4	3.0
EMT-20710A	2 Step	GeO ₂	.12	0.2	0.2
EMT-20783	2 Step	P ₂ O ₅	.11	49.0	7.9
EM-20495	1 Step	GeO ₂	.21	0.0	0.1
EMH-20627	1 Step	P ₂ O ₅	.17	0.8	0.2
EMH-20726B	2 Step	GeO ₂	.19	0.1	0.1
EMH-20730	2 Step	P ₂ O ₅	.19	0.0	0.0

2.3.4 Coating and Jacketing Evaluation

The effect of various fiber coating and jacketing material combinations on bending and microbending induced loss was investigated.

A high NA $\text{SiO}_2/\text{GeO}_2$ fiber fabricated by the one-step preform process was selected for tests. The selection was based on the high resistance for a similar test fiber, EM-20495, to both bending and microbending stress.

A single preform, EMH-20807, was fabricated as described in Section 2.2.4. The preform was then drawn into four different fibers. Each fiber had a different combination of coating and jacketing materials. The optical parameters measured for each fiber are listed in Table 2.3.4-1.

The fibers were next tested for bending and microbending sensitivity. The test equipment and procedures used were identical to those previously described for the earlier tests.

The bend loss tests showed negligible loss on the 12.7 and 9.3 mm mandrels. Test results for each fiber are shown in Appendix B. Bending losses after 20 turns on the 6.4 mm and 3.2 mm mandrels are shown in Figure 2.3.4-1. The figure shows that all jacket

Table 2.3.4-1 Optical Parameters for Fiber EMH-20807.

JACKET TYPE		ATTENUATION (± 0.3 dB/km)		
<u>Primary</u>	<u>Secondary</u>	<u>0.63 μm</u>	<u>0.83 μm</u>	<u>1.03 μm</u>
Soft	Soft	33.9	18.2	NT
Soft	Hard	28.3	16.0	NT
Hard	Soft	34.3	16.8	NT
Hard	Hard	27.1	11.7	73.5

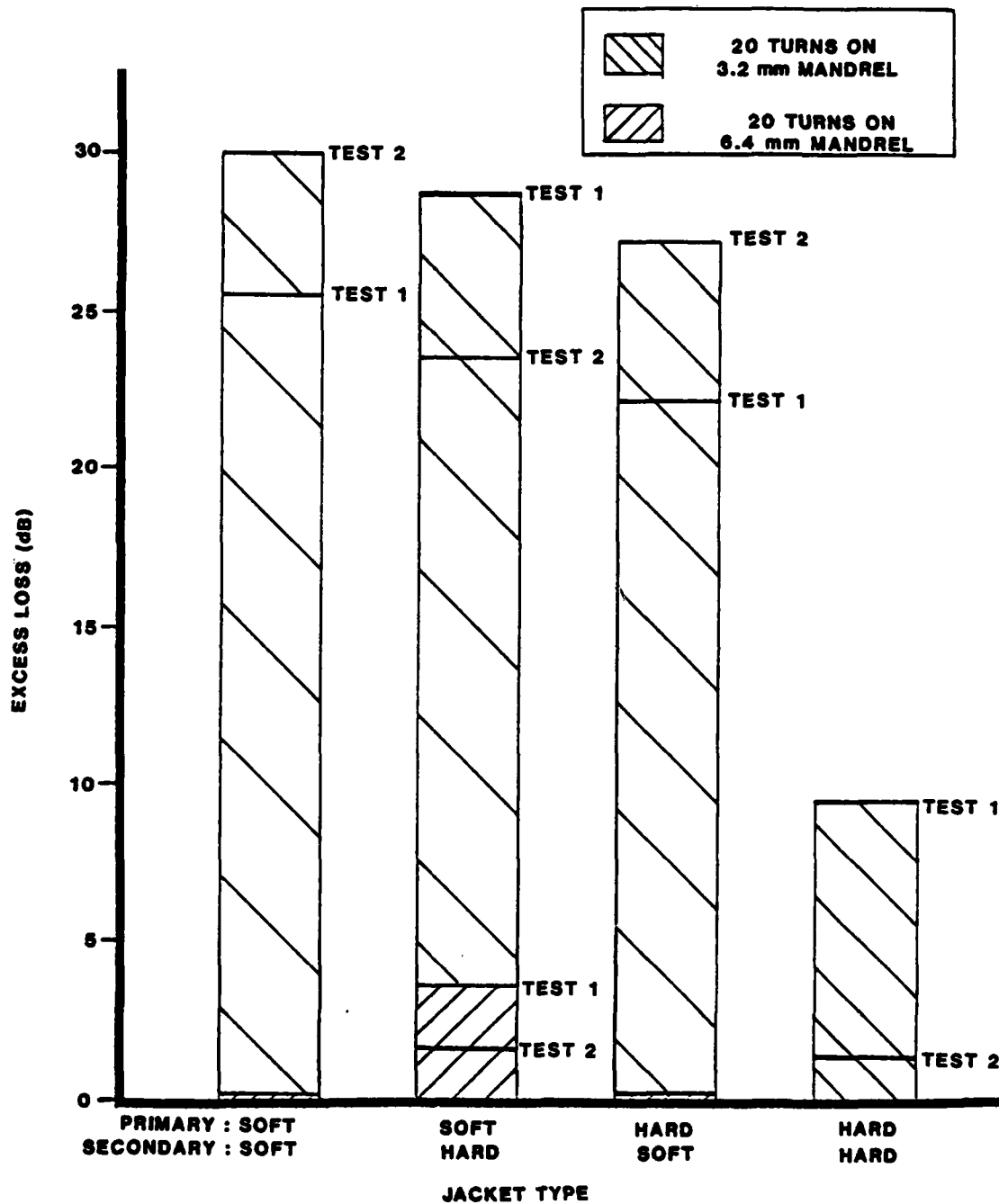

302 12261

Figure 2.3.4-1. Jacket Evaluation - Bend Loss Test Results.

combinations are similar in their effects except for the hard/hard combination which shows significantly lower loss.

The microbending tests showed similar results. Data for each fiber can be found in Appendix C, while a summary appears in Figure 2.3.4-2. The jacket combination of soft RTV and soft Hytrel[®] was easily damaged by the test apparatus and broke repeatedly. Again the hard/hard combination proved most resistant to microbending induced losses. The loss data in Table 2.3.4-1 seems to indicate that the fiber coated with hard/hard coating is operating closer to cut-off value than the others at 0.63 μm . This could explain the reduced bend and microbend loss sensitivity. This is, however, a single result and should be interpreted cautiously.

2.3.5 Eight Millimeter Mandrel Test

As a final test of microbending effects, 30 m of the fiber most resistant to microbending were wound onto an 8 mm diameter mandrel. The effects of this stress, designed to simulate a possible deployment packaging technique, were monitored at various intervals during the winding. The fiber, EMH-20730, was wound onto the mandrel using the radius control fixture shown in Figure 2.3.2-6. A fiber tensile load of 10 g was maintained on each side of the radius control fixture.

ITT *Electro-Optical Products Division*

The data obtained with the loss monitoring equipment is shown in Figure 2.3.5-1. The data shows a nearly linear increase in excess loss with wound fiber length to a maximum of 0.21 dB at 30 m.

Roanoke, Virginia

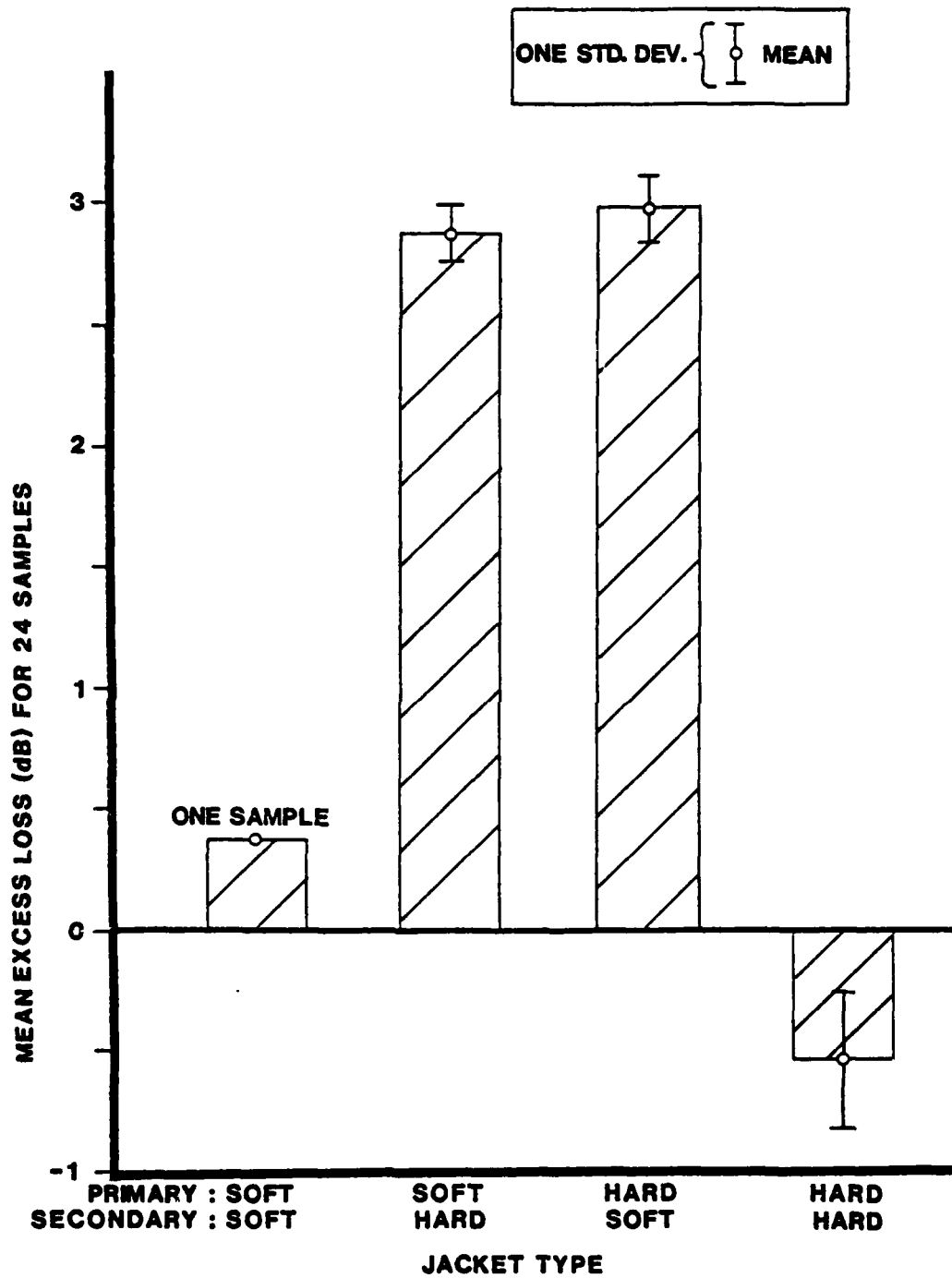

302 12263

Figure 2.3.4.2. Jacket Evaluation: Microbend Loss Test Results.

EMH-20730: 1 STEP, HI NA, GE02 CORE

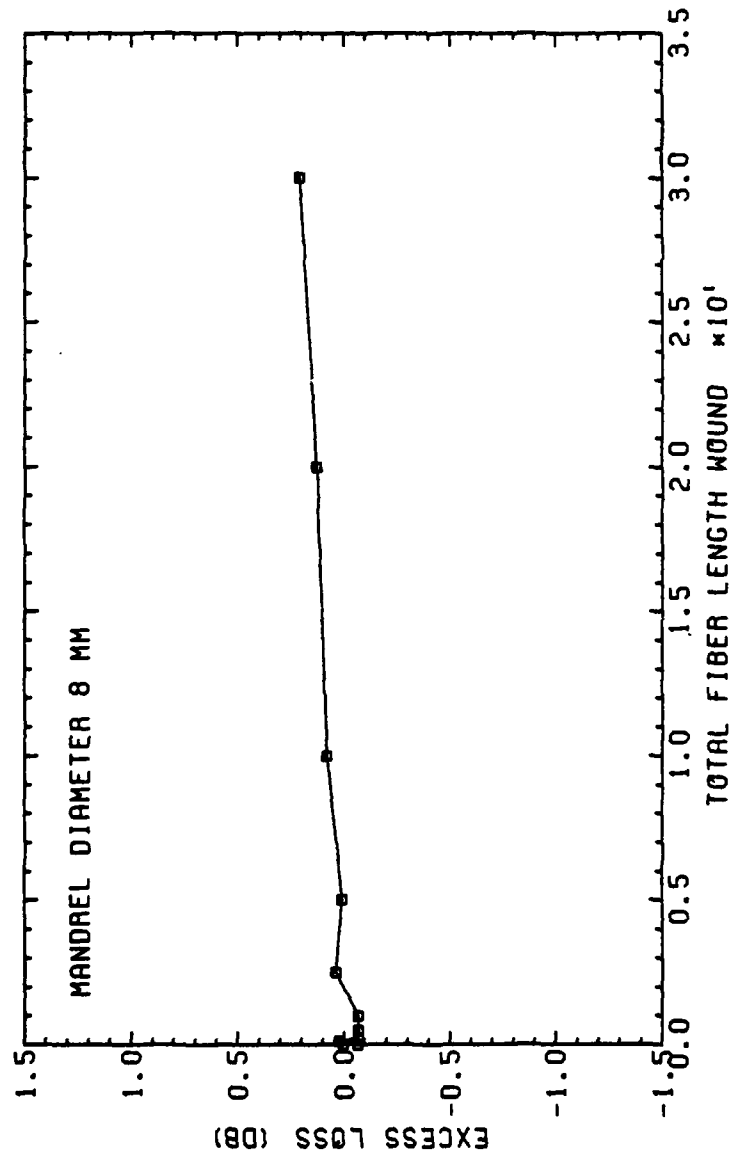

Figure 2.3.5-1, Eight Millimeter Mandrel Test Results.

3.0 CONCLUSIONS AND RECOMMENDATIONS

The experimental effort performed under this program has clearly established that ≥ 0.17 NA single mode fibers are insensitive to bending and microbending losses while < 0.12 single mode fibers exhibit bending and microbending losses which would prohibit their use in tightly coiled configurations. Of the high NA fiber types tested, the GeO_2 doped SiO_2 core fiber was more resistant to bending losses when wrapped on a 3.2 mm mandrel than the P_2O_5 doped SiO_2 core fiber. In addition, one test performed during this program indicated that a fiber jacket combination consisting of a relatively "hard" silicone primary coating and a "hard" polyester secondary coating was superior to softer coatings tested in reducing both bending and microbending losses. Furthermore, it was demonstrated that a 30 m length of high NA single mode fiber could be tightly wound onto an 8 mm mandrel with a resulting attenuation increase of 0.3 dB.

Based on the results achieved and the observations made during this contract, EOPD offers the following recommendations to further improve the performance characteristics of high NA single mode fibers.

- a. Reduce the unstressed optical losses in high NA single mode fibers by reducing intrinsic scattering and waveguide material imperfection losses. Those losses can be reduced by optimization of core and cladding dopant concentrations and by optimization of preform and fiber fabrication parameters.

Roanoke, Virginia

ITT *Electro-Optical Products Division*

- b. Improve mechanical strength of low loss high NA single mode fibers to increase time to failure when coiled over small mandrels.
- c. Further evaluate the effects of jacket hardness on fiber bend and microbend losses. Selection of primary and secondary jacket materials would be based on the effects of aqueous environments on attenuation and fiber durability.

Roanoke, Virginia

Bend Loss Plots: Test 2

Appendix A

Roanoke, Virginia

1 STEP, LO NA, GE02 CORE

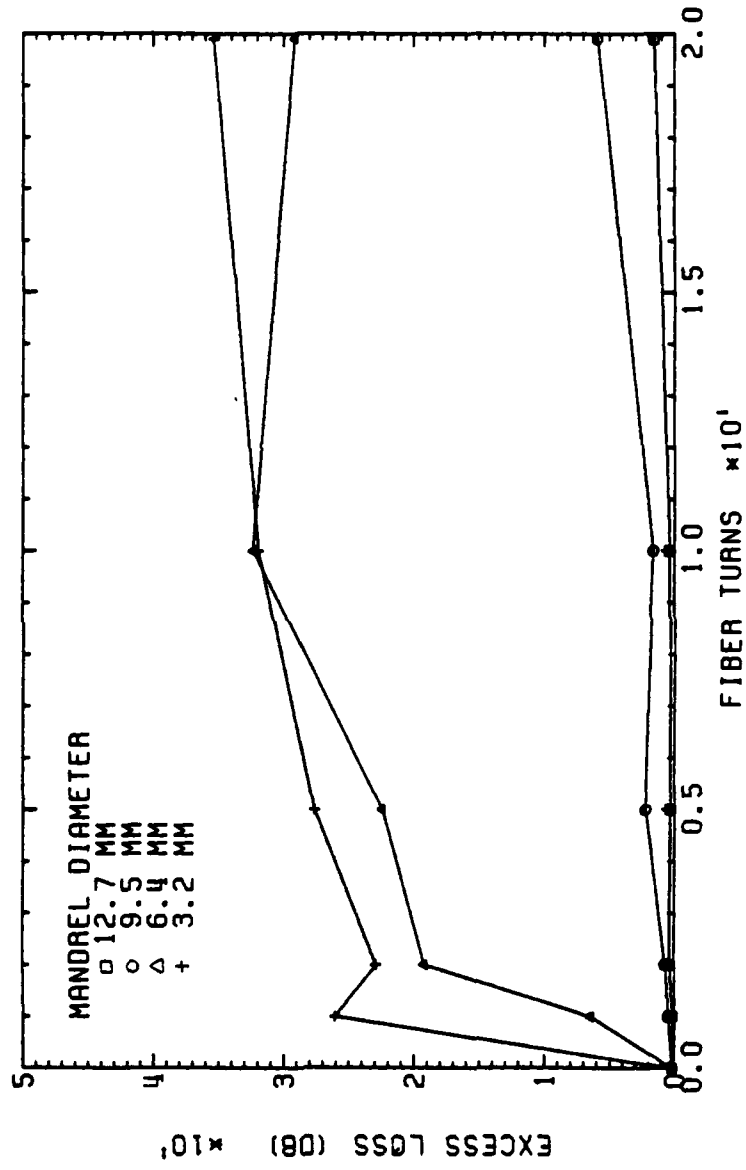

FIGURE A-1. EMT-20721 BEND LOSS RESULTS: TEST 2

1 STEP, L0 NA, P205 CORE

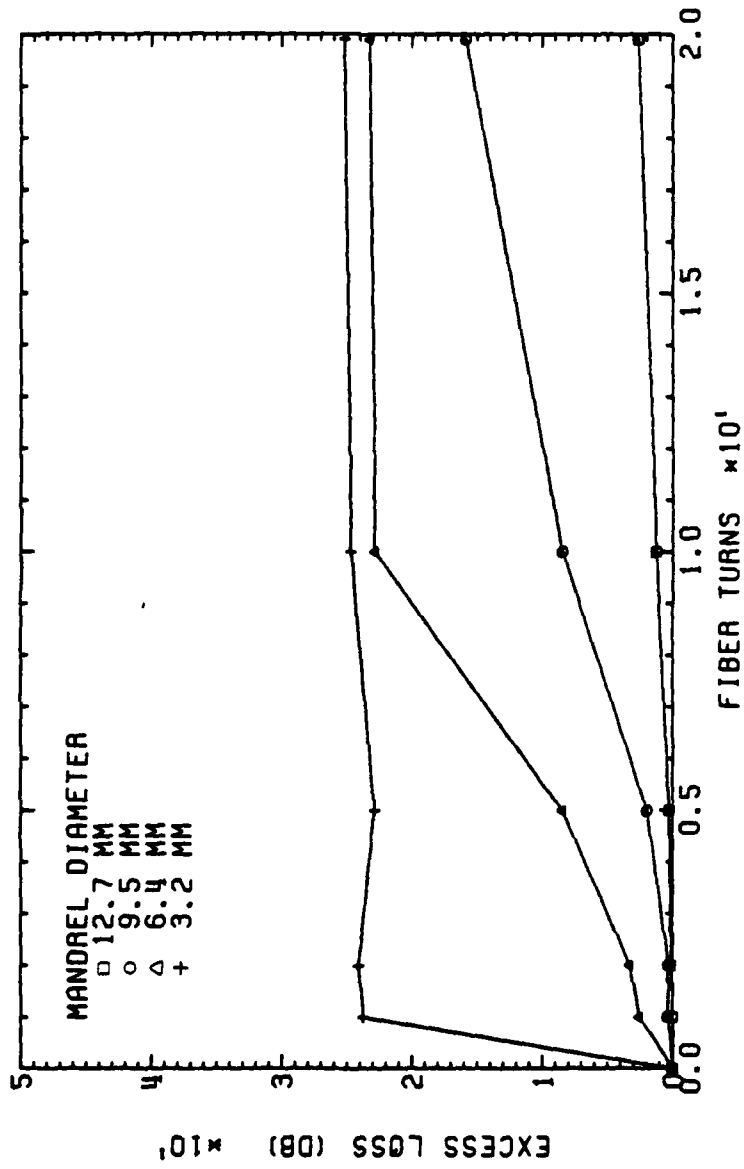

FIGURE A-2. EMT-20738 BEND LOSS RESULTS: TEST 2

1 STEP, HI NA, GE02 CORE

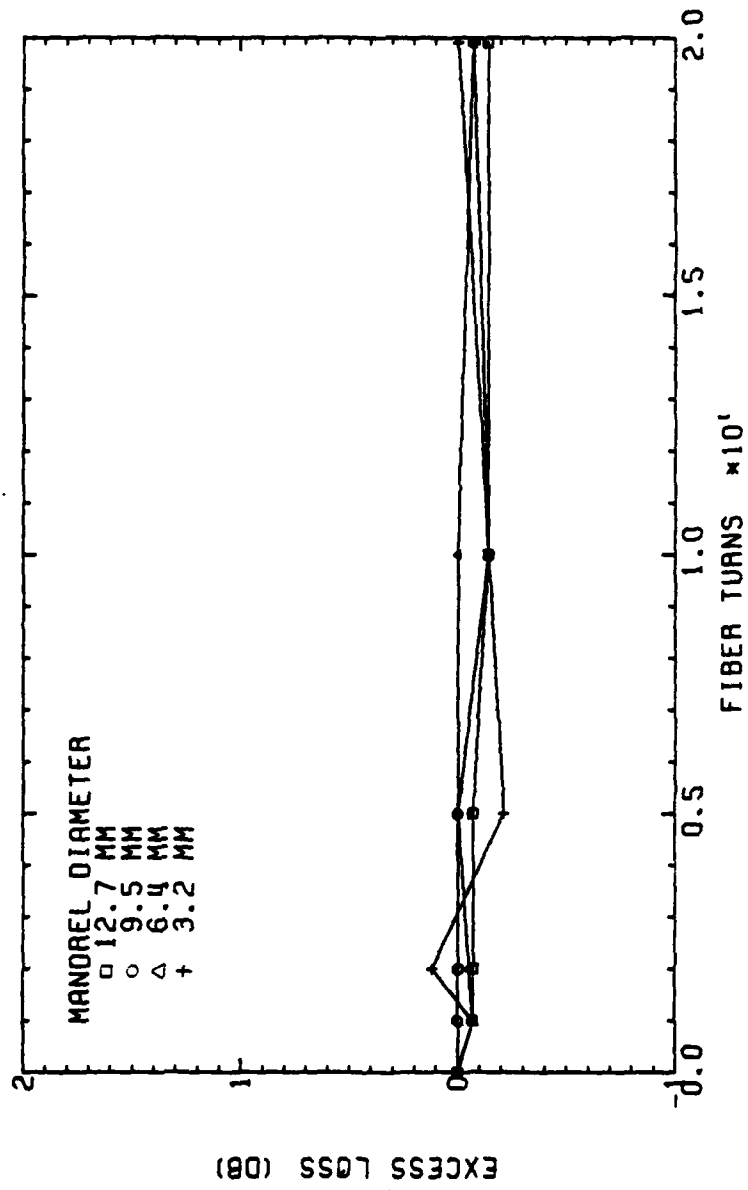

FIGURE A-3. EM-20495 BEND LOSS RESULTS: TEST 2

1 STEP, HI NA, P205 CORE

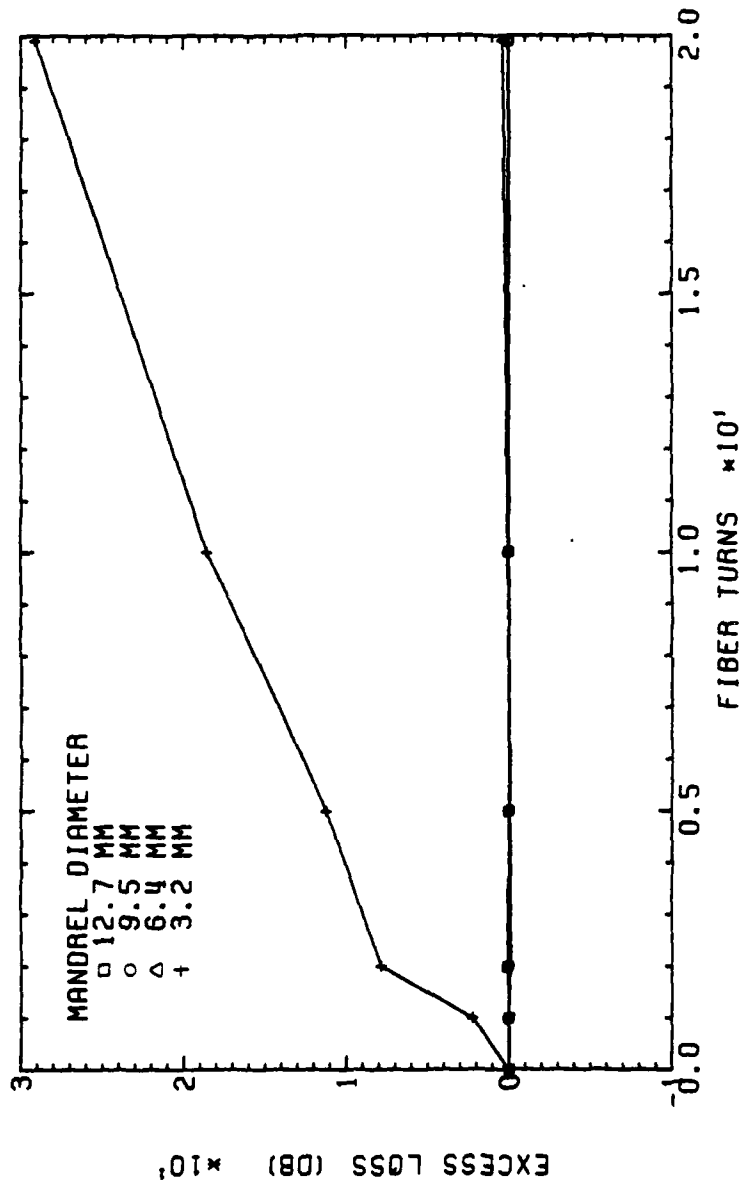

FIGURE A-4. EMH-20627 BEND LOSS RESULTS: TEST 2

2 STEP, LO NA, GE02 CORE

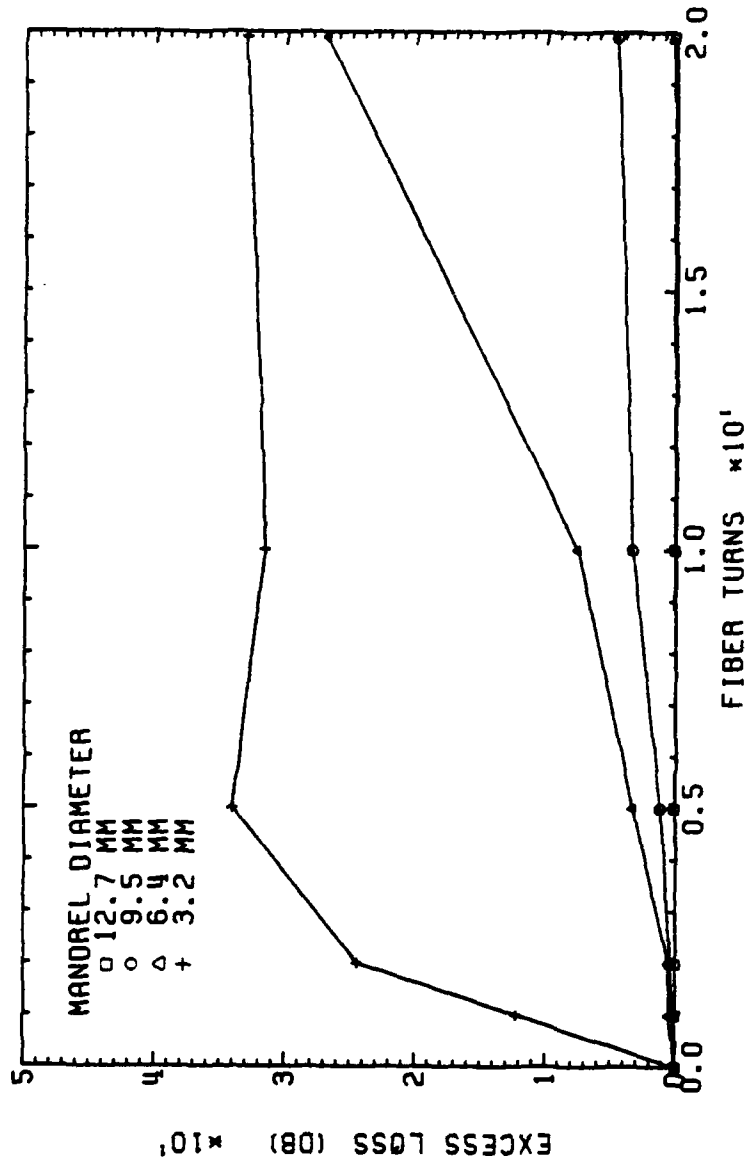

FIGURE A-5. EMT-20710A BEND LOSS RESULTS: TEST 2

2 STEP, LO NA, P205 CORE

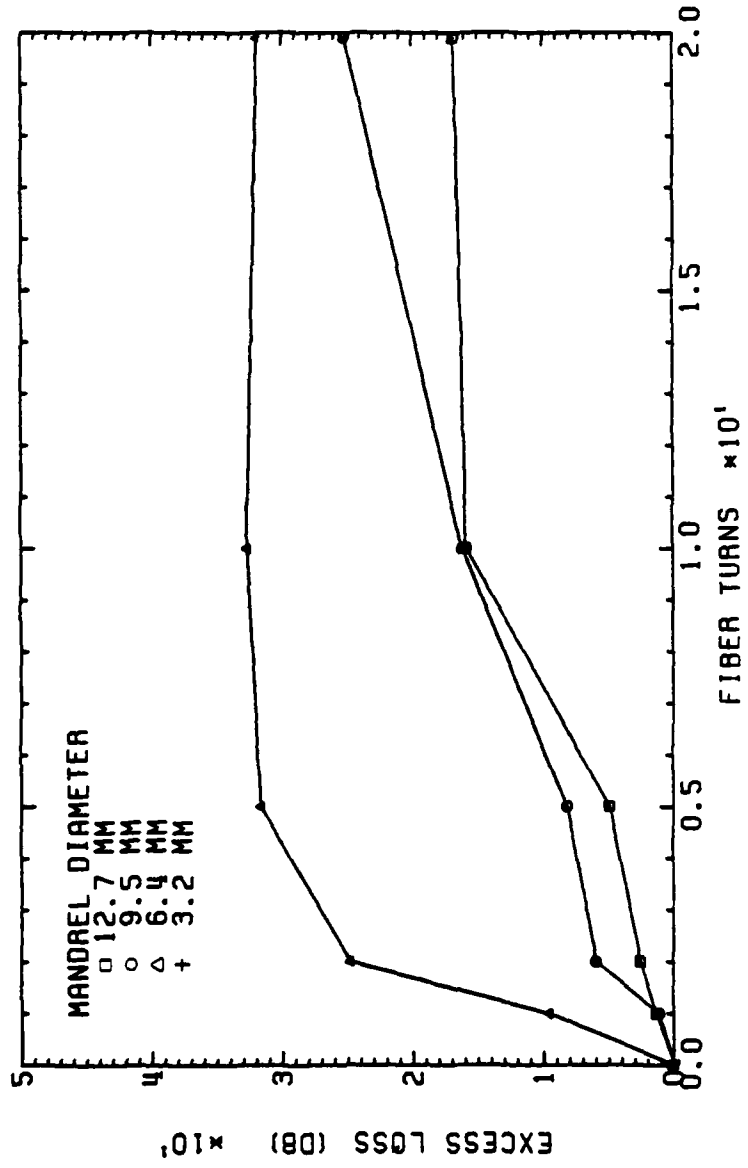

FIGURE A-6. EMT-20783 BEND LOSS RESULTS: TEST 2

2 STEP, HI NA, GE02 CORE

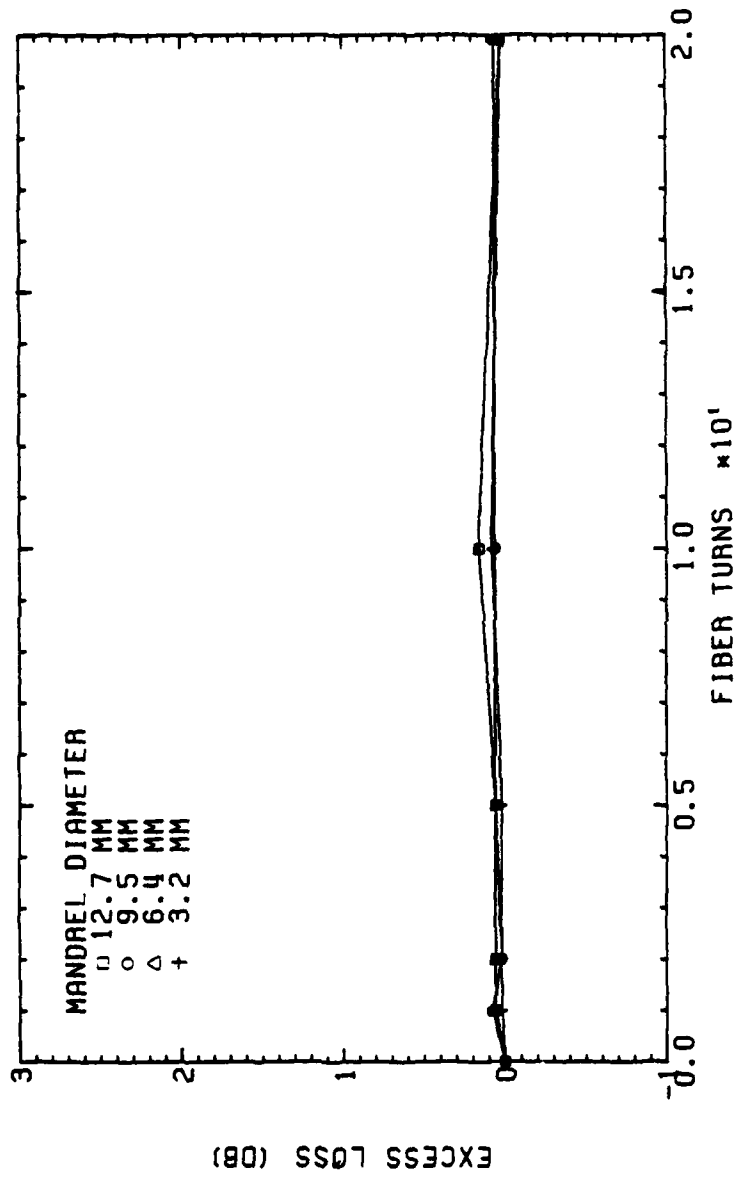

FIGURE A-7. EMH-20726B BEND LOSS RESULTS: TEST 2

2 STEP, HI NA, P205 CORE

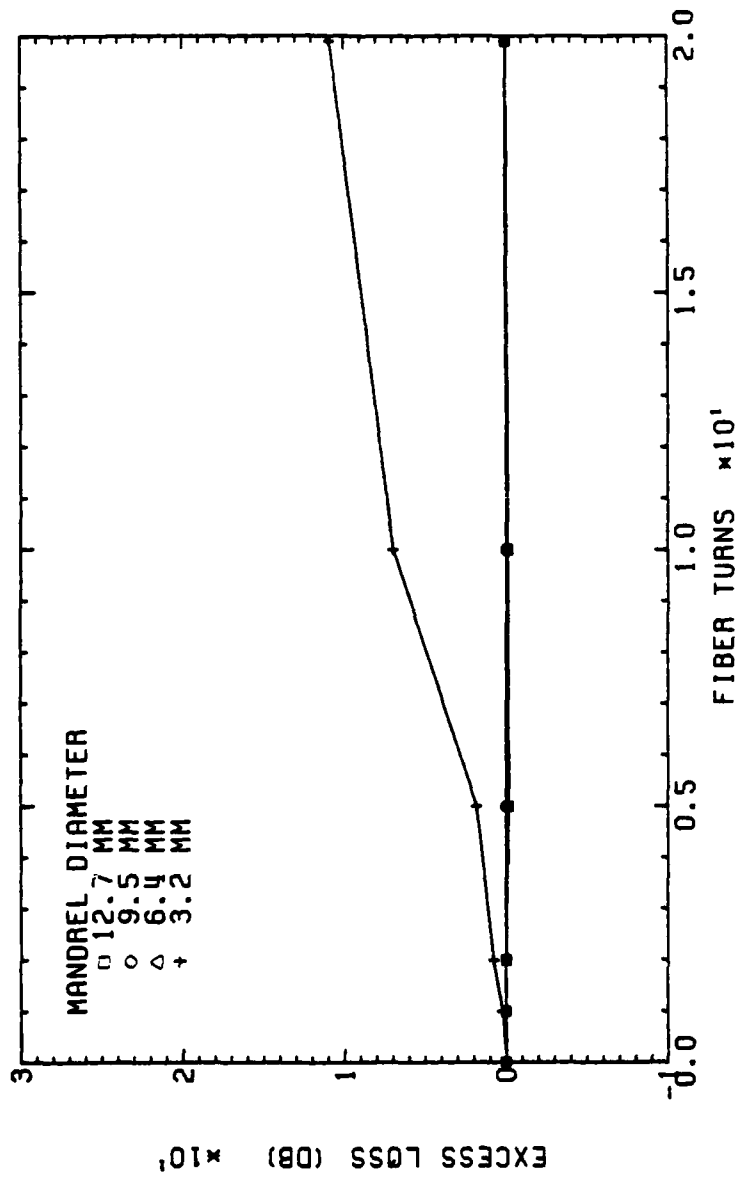

FIGURE A-8. EMH-20730 BEND LOSS RESULTS: TEST 2

ITT *Electro-Optical Products Division*

Jacket Evaluation: Bend Loss Plots

Appendix B

Roanoke, Virginia

B-1

EMH-20807: 1 STEP, HI NA, GE02 CORE

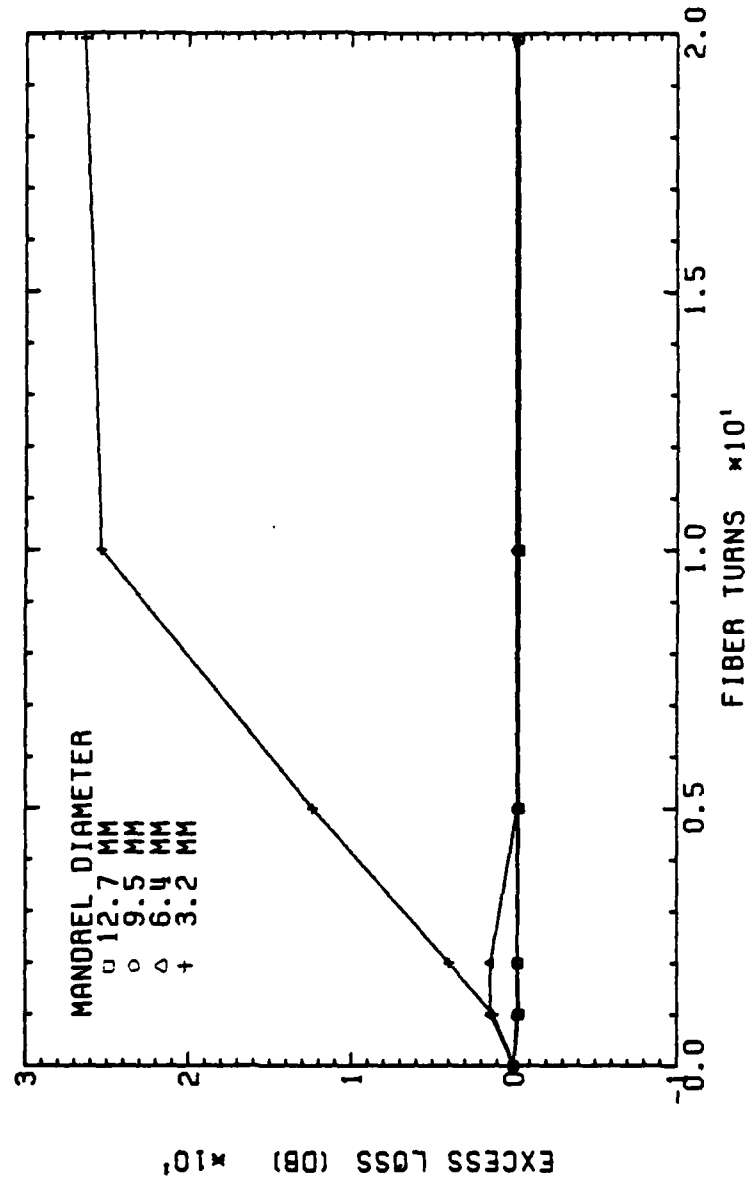

FIGURE B-1. SOFT/SOFT JACKET BEND TEST 1

EMH-20807: 1 STEP, HI NA, GE02 CORE

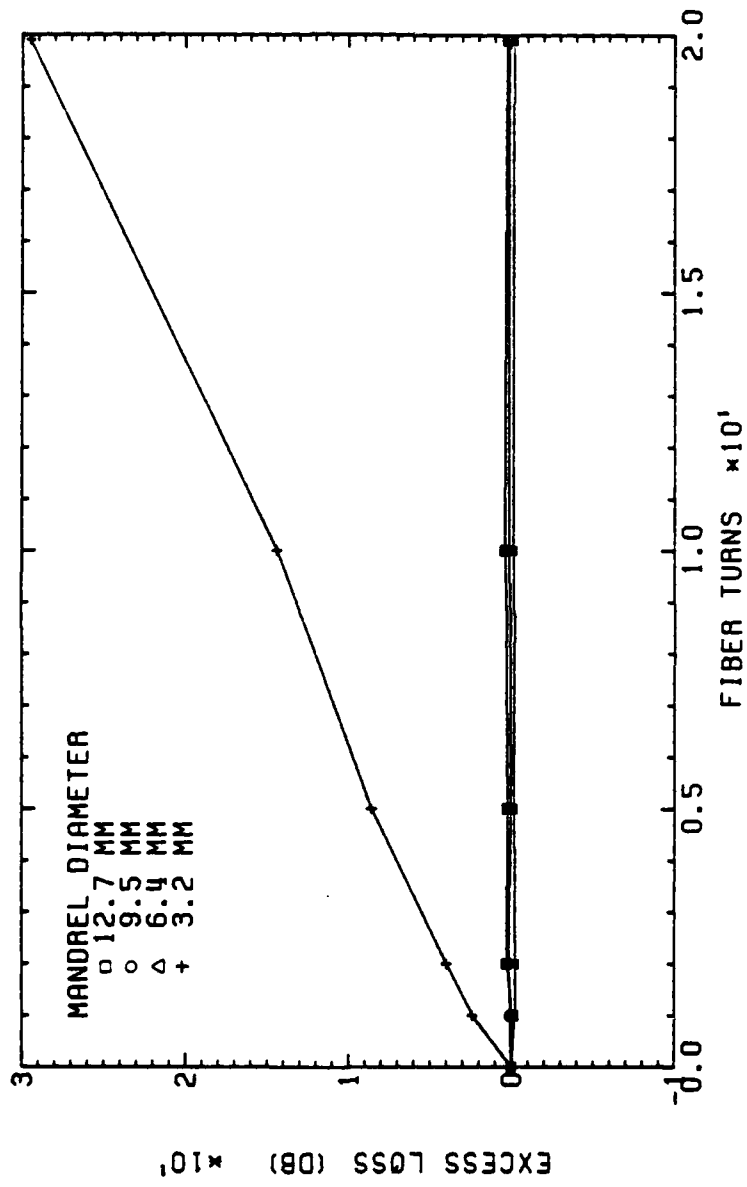

FIGURE B-2. SOFT/SOFT JACKET BEND TEST 2

EMH-20807: 1 STEP, HI NA, GE02 CORE

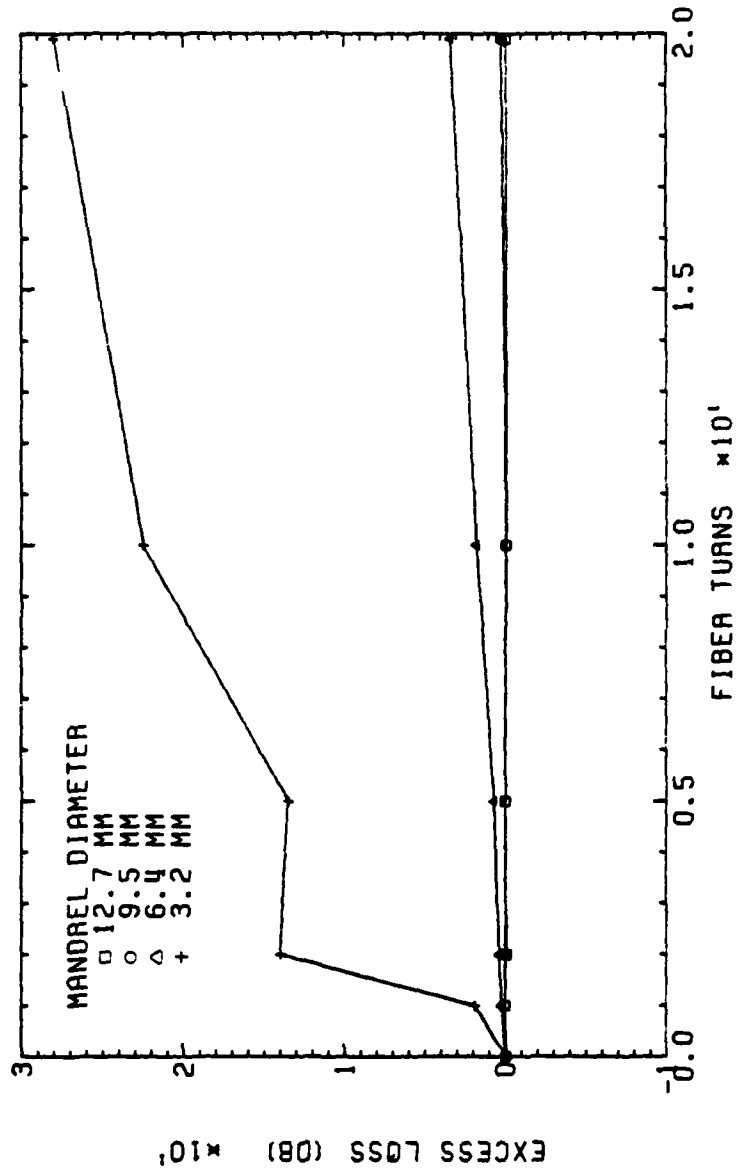

FIGURE B-3. SOFT/HARD JACKET BEND TEST 1

EMH-20807: 1 STEP, HI NA, GE02 CORE

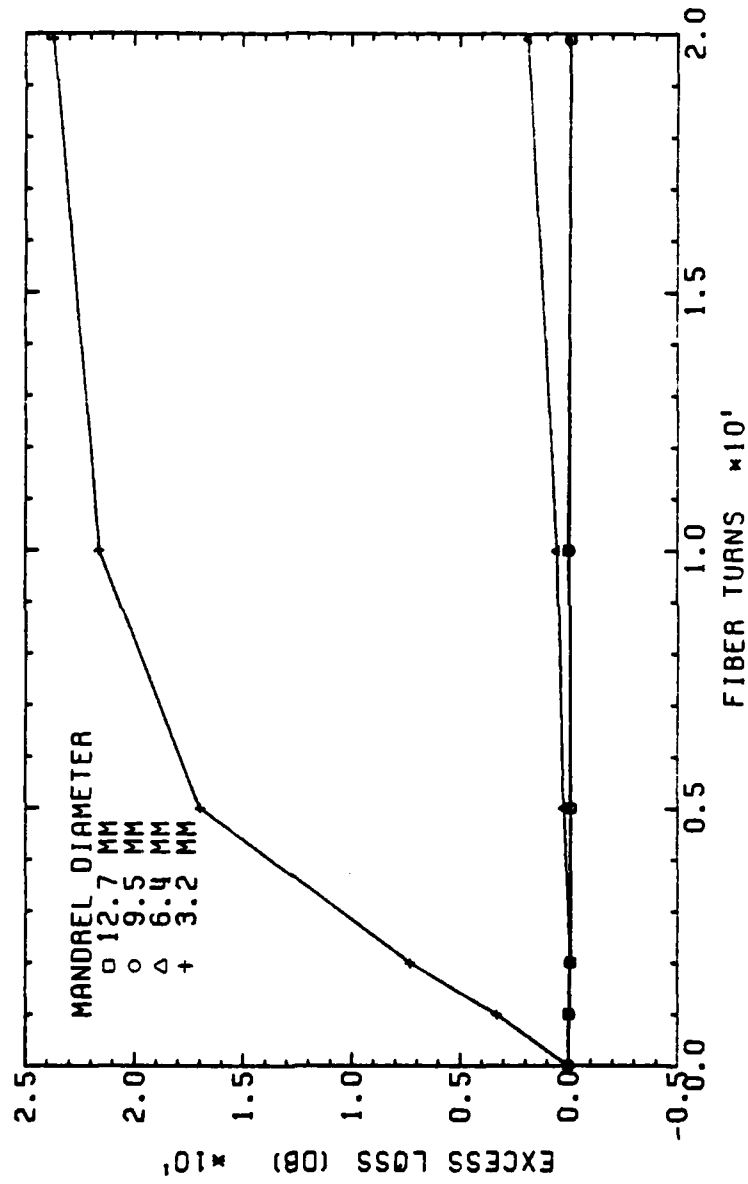

FIGURE B-II. SOFT/HARD JACKET BEND TEST 2

EMH-20807: 1 STEP, HI NA, GE02 CORE

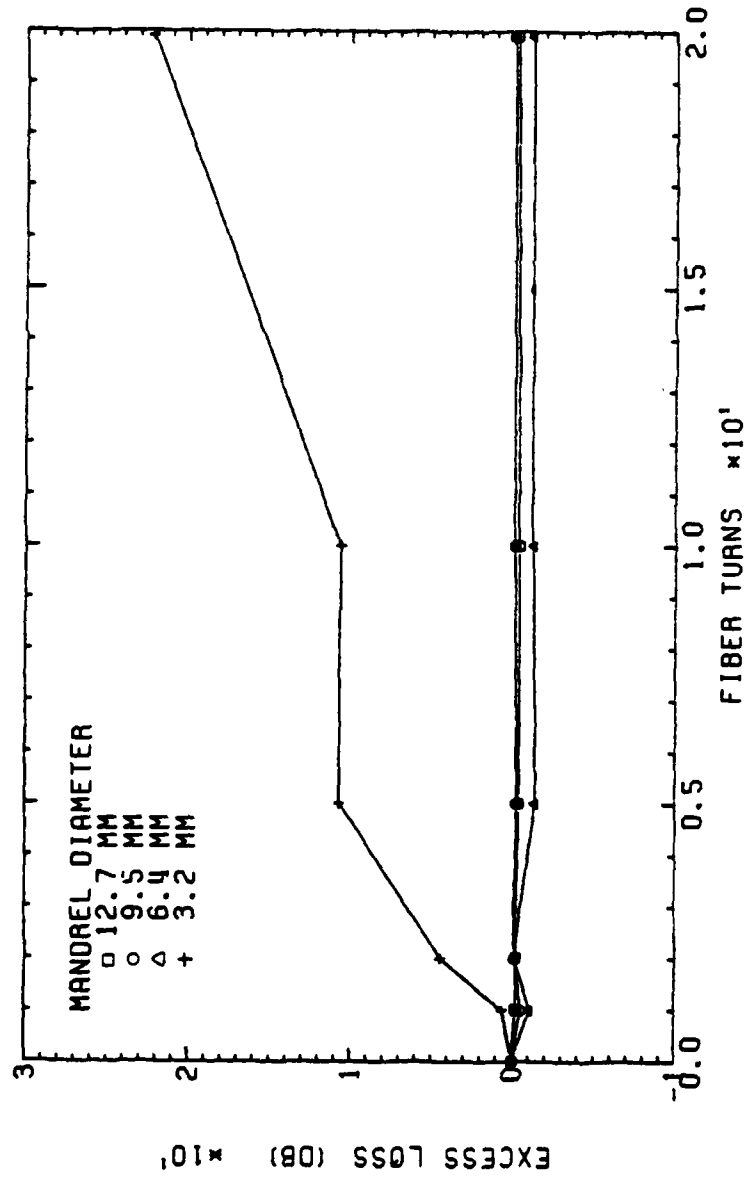

FIGURE B-5. HARD/SOFT JACKET BEND TEST 1

EMH-20807: 1 STEP. HI NA, GE02 CORE

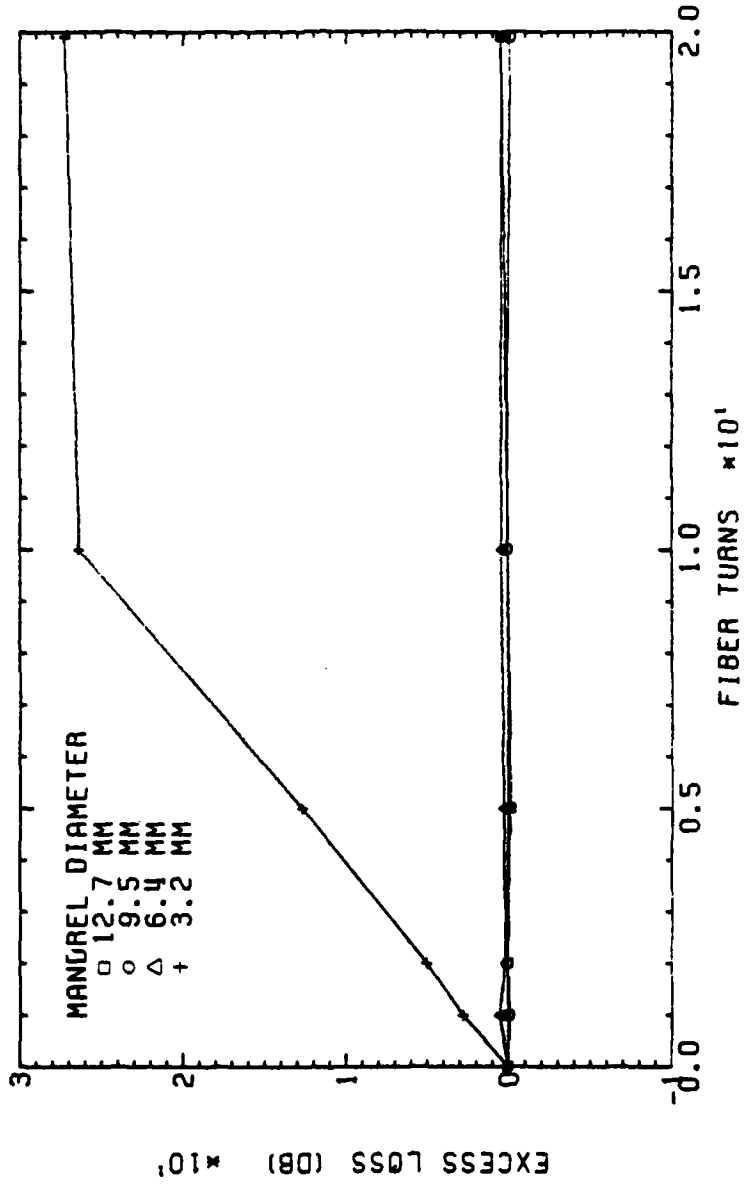

FIGURE B-6. HARD/SOFT JACKET BEND TEST 2

EMH-20807: 1 STEP, HI NA, GE02 CORE

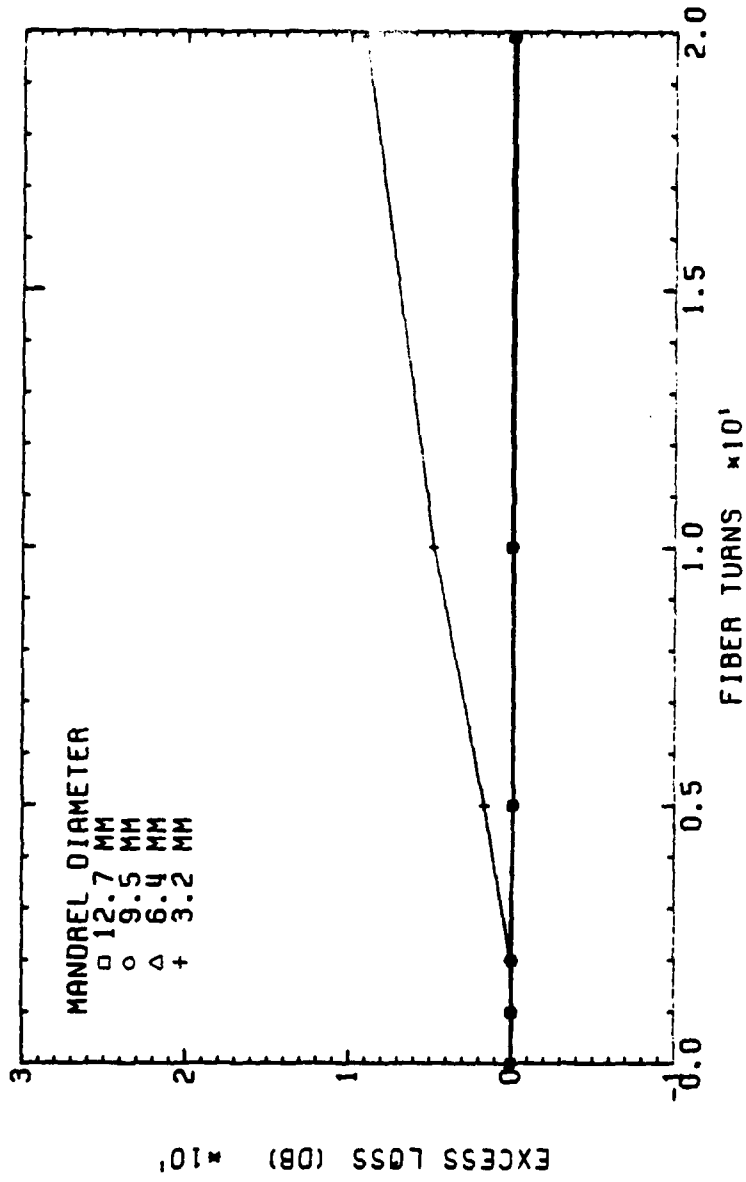

FIGURE B-7. HARD/HARD JACKET BEND TEST I

EMH-20807: 1 STEP, HI NA, GE02 CORE

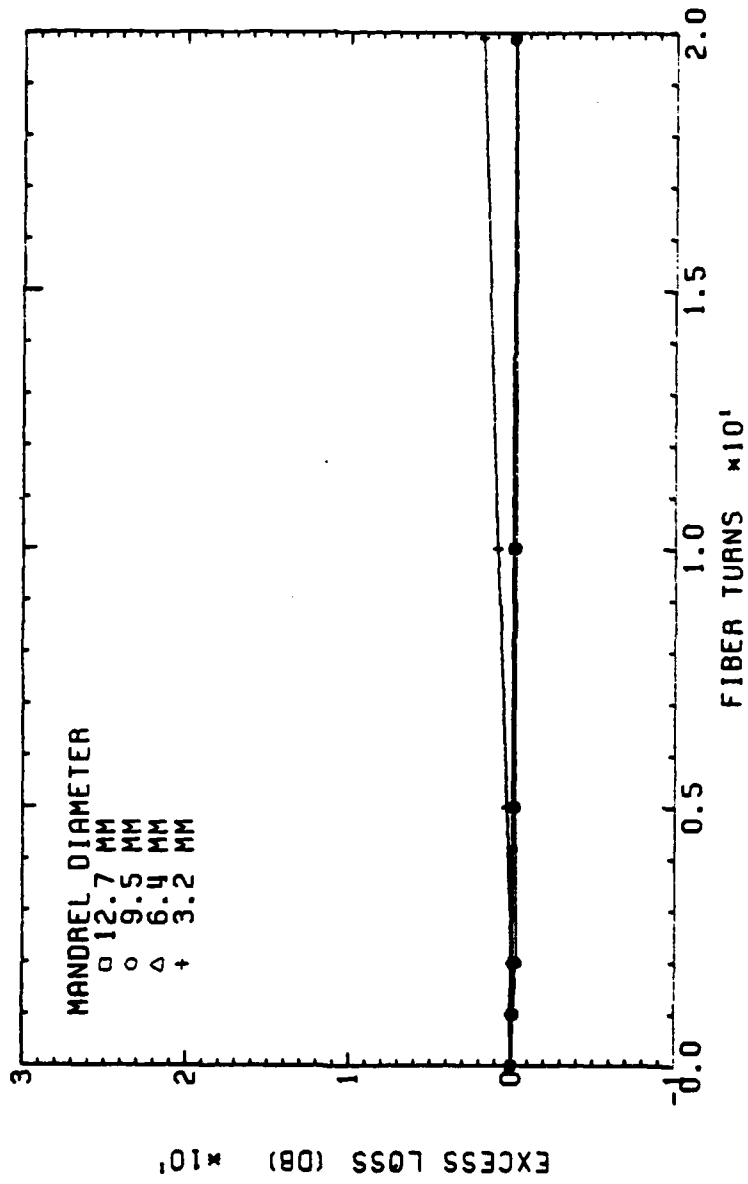

FIGURE B-8. HARD/HARD JACKET BEND TEST 2

ITT *Electro-Optical Products Division*

Jacket Evaluation: Microbend Loss Plots.

Appendix C

Roanoke, Virginia

C-1

EMH-20807: 1 STEP, HI NA, GE02 CORE

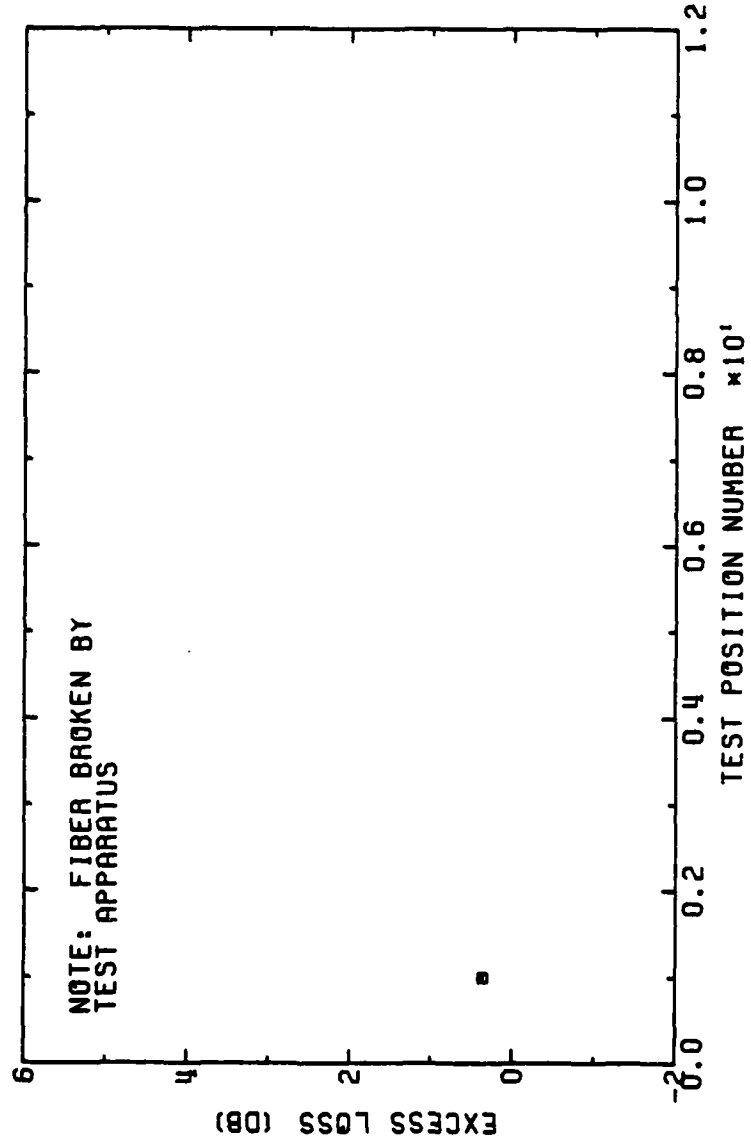

FIGURE C-1. SOFT/SOFT JACKET MICROBEND TEST RESULTS

EMT-20807: 1 STEP, HI NA, GE02 CORE

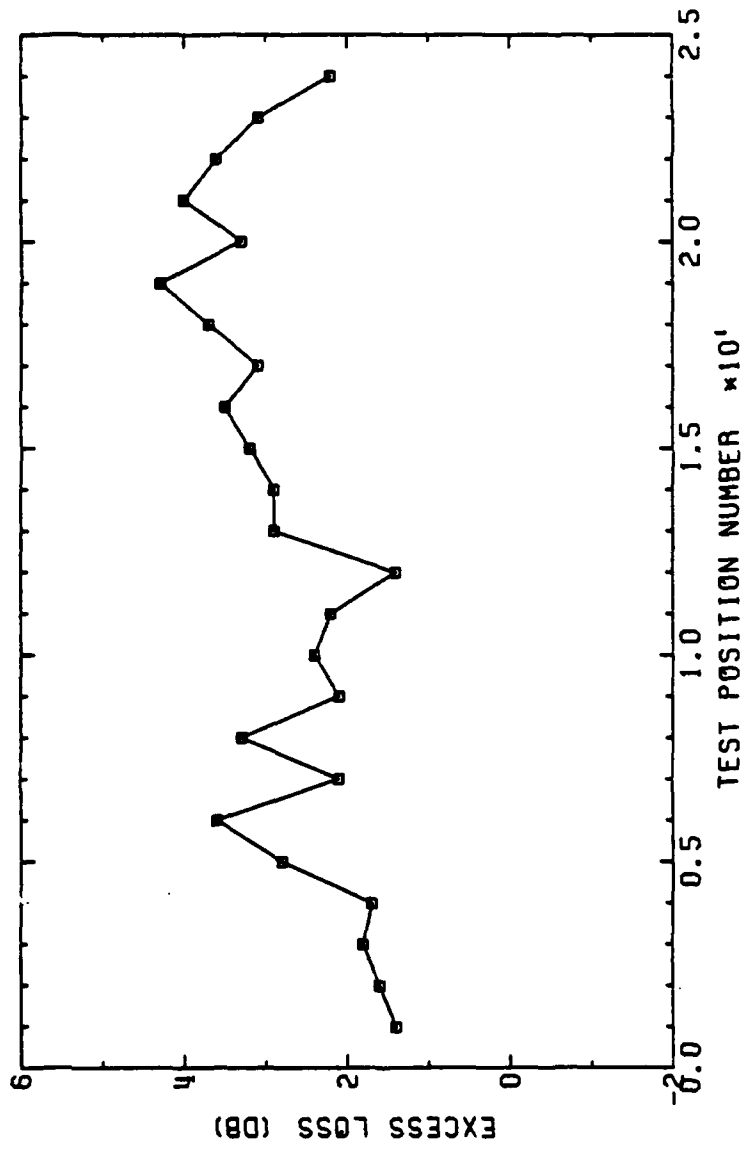

FIGURE C-2. SOFT/HARD JACKET MICROBEND TEST RESULTS

EMH-20807: 1 STEP, HI NA, GE02 CORE

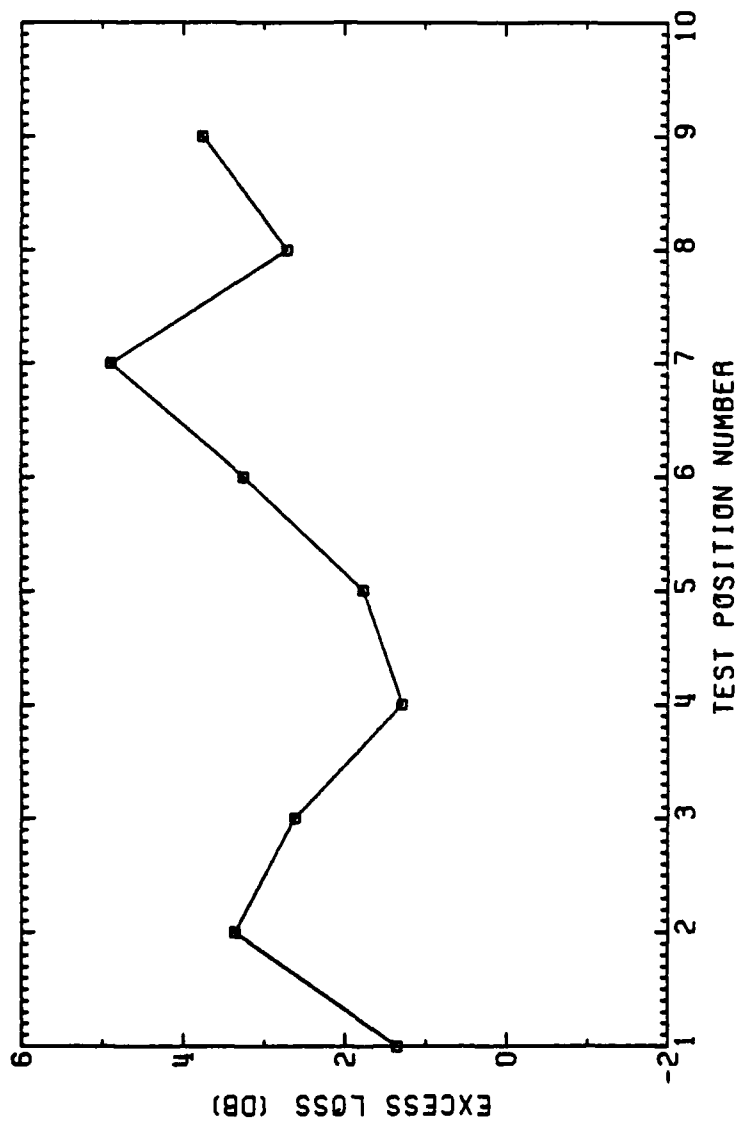

FIGURE C-3. HARD/SOFT JACKET MICROBEND TEST RESULTS

EMH-20807: 1 STEP, HI NA, GE02 CORE

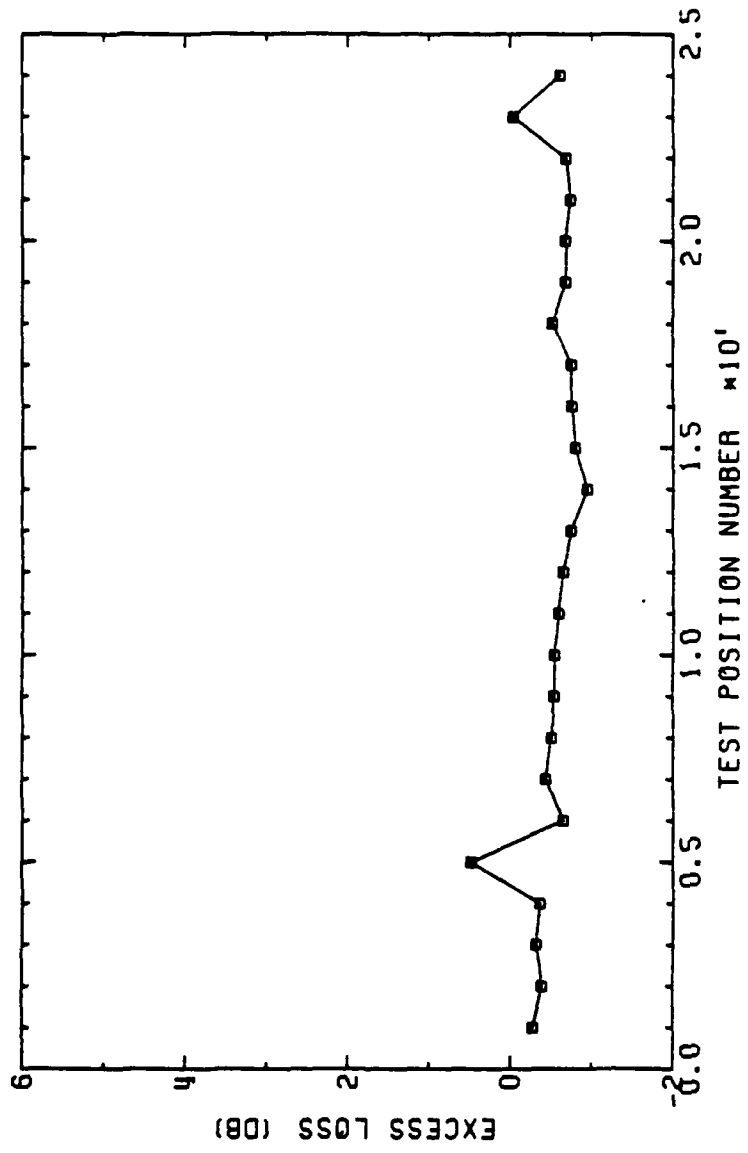

FIGURE C-4. HARD/HARD JACKET MICROBEND TEST RESULTS