



LEVEL 4

12

✓ RESEARCH AND DEVELOPMENT TECHNICAL REPORT
DELET-TR-80-2

ADA081522

**AUTOCLAVE TESTING OF PLASTIC ENCAPSULATED 400I CMOS
INTEGRATED CIRCUITS**

DTIC
SELECTED
MAR 13 1980

Richard Holevinski
ELECTRONICS TECHNOLOGY & DEVICES LABORATORY

January 1980

DISTRIBUTION STATEMENT
Approved for public release;
distribution unlimited.

ERADCOM

**US ARMY ELECTRONICS RESEARCH & DEVELOPMENT COMMAND
FORT MONMOUTH, NEW JERSEY 07703**

80 3 7 020

NOTICES

Disclaimers

The citation of trade names and names of manufacturers in this report is not to be construed as official Government indorsement or approval of commercial products or services referenced herein.

Disposition

Destroy this report when it is no longer needed. Do not return it to the originator.

UNCLASSIFIED

SECURITY CLASSIFICATION OF THIS PAGE (When Data Entered)

REPORT DOCUMENTATION PAGE		READ INSTRUCTIONS BEFORE COMPLETING FORM	
1. REPORT NUMBER DELET-TR-80-2	2. GOVT ACCESSION NO.	3. RECIPIENT'S CATALOG NUMBER	
4. TITLE (and Subtitle) Autoclave Testing of Plastic Encapsulated 4001 CMOS Integrated Circuits	5. TYPE OF REPORT & PERIOD COVERED Technical Report		
7. AUTHOR(s) Richard Holevinski	6. PERFORMING ORG. REPORT NUMBER		
9. PERFORMING ORGANIZATION NAME AND ADDRESS US Army Electronics Research & Development Cmd ATTN: DELET-IR, ET&D Laboratory Fort Monmouth, New Jersey 07703	8. CONTRACT OR GRANT NUMBER(s)		
11. CONTROLLING OFFICE NAME AND ADDRESS	10. PROGRAM ELEMENT, PROJECT, TASK AREA & WORK UNIT NUMBERS 1L162705AH94 06/11		
14. MONITORING AGENCY NAME & ADDRESS (if different from Controlling Office) 12 501	12. REPORT DATE 11 January 1980		
	13. NUMBER OF PAGES 26		
	15. SECURITY CLASS. (of this report) Unclassified		
15a. DECLASSIFICATION/DOWNGRADING SCHEDULE			
16. DISTRIBUTION STATEMENT (of this Report) Approved for public release; distribution unlimited			
17. DISTRIBUTION STATEMENT (of the abstract entered in Block 20, if different from Report)			
18. SUPPLEMENTARY NOTES			
19. KEY WORDS (Continue on reverse side if necessary and identify by block number) Integrated circuits Reliability (electronics) Autoclave Testing Corrosion Complementary Metal Oxide Semiconductors Encapsulation Failure Analysis Weibull Distributions			
20. ABSTRACT (Continue on reverse side if necessary and identify by block number) Samples from 10 vendors of CMOS 4001 plastic encapsulated integrated circuits were tested in an autoclave at 121°C, 100% RH and 15 psig with and without electrical bias. Twenty-nine test groups of 16 circuits each accumulated over 200,000 device hours. Failure analyses were performed to verify moisture related electrochemical aluminum metal corrosion on the die. Weibull failure distributions showed large differences in moisture resistance reliability among the various vendor products. Test devices with newer date coded packages had longer median life times. There was no correlation of median			

20. (Contd)

life time between groups with and without electrical bias.

Accession For	
NTIS GRA&I	<input checked="" type="checkbox"/>
DOC TAB	<input type="checkbox"/>
Unannounced	
Justification	
By _____	
Distribution/	
Availability Codes	
Dist	Avail and/or special
A	

TABLE OF CONTENTS

	<u>Page</u>
INTRODUCTION	1
TEST PROGRAM	1
FAILURE ANALYSIS	2
FAILURE DATA DISTRIBUTIONS	4
CONCLUSIONS	5

TABLES

1. 4001 CMOS Autoclave Test Matrix	6
2. Physical Dimensions	7
3. Weibull Distributions for 5 Volt Bias Autoclave Test	8
4. Weibull Distributions for No Bias (Storage) Autoclave Test	8

FIGURES

1. Electrical bias in autoclave	9
2. An exploded view of the ceramic packages	10
3. Micrographs of Type 4001 die from vendors A and B	11
4. Micrographs of Type 4001 die from vendors C and D	12
5. Micrographs of Type 4001 die from vendors E and F	13
6. Micrographs of Type 4001 die from vendors G, H, I and J	14
7. Radiographs of the different package styles tested	15

APPENDICES

A Weibull Probability Distributions	16-25
-------------------------------------	-------

INTRODUCTION

Plastic encapsulated devices (PEDs) with potential use in new military equipment have been investigated by the Electronics Technology and Devices Laboratory of the US Army Electronics Research and Development Command.^{1,2} A long-term moisture-resistance test program has been in operation at the Army Tropic Test Center in the Panama Canal Zone since 1970 representing a "worst case" field test condition of 30°C average temperature and 80 to 100% relative humidity (RH).

To complement the long-term Panama Program, a laboratory test program was initiated to obtain accelerated moisture resistance results on some of the same group of PEDs presently being tested in Panama. The PEDs selected were subjected to accelerated humidity test conditions of 121°C/100%RH/15psig in a modified laboratory autoclave chamber. Type 4001 complementary metal oxide-semiconductor (CMOS) quad 2-input NOR circuits were selected for evaluation since they were commercially available from different vendors, an important consideration since components are purchased on a multisource basis. Several vendors have performed accelerated humidity tests on their various products, each using his own failure criterion; this failure criterion however, is not uniform from vendor to vendor.^{3,4} In this program, all electrical testing and failure criteria were standardized so that comparisons of PED moisture resistance, between vendors, could easily be made.

TEST PROGRAM

The 4001 CMOS circuits were arranged into 29 test groups comprised of 16 devices each. Each group of circuits was soldered onto one printed circuit board for ease of handling and testing. Table 1 shows the 4001 CMOS autoclave testing matrix which was used to evaluate the PEDs for moisture resistance. The circuits were all purchased through regular distributors to obtain parts of the quality being used by industry. Each vendor's group of circuits was sorted by package date code so that circuits with the same date codes were considered as a single lot for testing purposes. Four vendors had groups organized into test lots with circuits that contained several package date codes. A second test lot of circuits, with package date codes approximately 3 years apart, were purchased from some of the vendors for moisture resistance comparisons. Two groups of ceramic packaged circuits (A4, A5) were included in the program as control groups to observe their moisture resistance.

- 1 B. Reich and E. Hakim, "The Use of Reliable Plastic Semiconductors in Military Equipment," *Microelectronics and Reliability*, Vol. 15, 1976.
- 2 E. Hakim and H. Schauer, "Panama Field Test Results of Plastic Encapsulated Devices," *Proceedings of ERADCOM Symposium on Plastic Encapsulated Polymer Sealed Semiconductor Devices for Army Equipment*, May 1978.
- 3 N. Lycoudes, "The Reliability of Plastic Micocircuits in Moist Environments," *Solid State Technology*, October 1978.
- 4 J. W. Peeples, "Electric Bias Level Influence on THB Results of Plastic Encapsulated NMOS 4K RAM's," *Proceedings, 16th IEEE Reliability Physics Symposium*, 1978.

The groups were tested in the autoclave with either 5 volts electrical bias or with no bias, a storage condition. Figure 1 shows the electrical schematic of the biased test circuits in the autoclave. The bias potentials were not applied to circuits being tested under storage conditions. Measured power dissipation for each 4001 circuit was typically from 1 to 3 nanowatts. This circuit design kept each alternate gate on each die at either an electrical "HI" or "LO" bias level, thus insuring potential differences between aluminum intraconnects on the die. This circuit design also facilitated logic tests of the NOR gates on each device. Each logic test was conducted by connecting input logic signals to parallel pins 5 and 6 while monitoring the output of the series NOR gates at pin 10. A malfunction of any of the gates was immediately obvious by the termination of the resulting switching states. Initial electrical verification of each circuit function was conducted before the circuits were autoclave tested. At 24 hour time intervals, the circuits were removed from the autoclave and electrical circuit functions verified. Any circuits accumulating over 1008 hours in the autoclave chamber were then removed from the autoclave for verification of electrical circuit functions at 168 hour time intervals. A room temperature drying time of less than one hour was sufficient to remove all external moisture from the packages, before electrically verifying the devices. Each group was tested in the autoclave until a majority of population failures occurred. Several groups - A3, A5 and F2 were on storage test in the autoclave for over 3700 hours.

FAILURE ANALYSIS

A complete failure analysis was performed on failed circuits after removal from the printed circuit board. Electrical failure verification consisted of electrically switching each of the four individual NOR gates on the die thus determining the failure mode. Each external lead was then probed using a curve-tracer to check individual voltage-current characteristics. The failure analysis revealed that all failures were due to either open internal connections or highly degraded voltage-current characteristics, causing one or more of the NOR gates to malfunction.

The PEDs were decapsulated with chemical solvents to expose each die for failure analysis.⁵ Hot fuming nitric acid was used to decapsulate all of the epoxy packages. Group A1 had a two epoxy package formulation; the outer epoxy was removed with the hot fuming nitric acid and the inner epoxy junction coating was removed with hot fuming sulfuric acid. Silicone packages in group B1 were removed with Unresolve Plus, a commercial decapsulant from Dynaloy, Inc. The caps of the ceramic packages in Groups A3 and A4 were filed off.

During failure analysis, bonding wire diameters and chip dimensions were recorded and are shown in Table 2. Gold bonding wires were thermal-compression-ball-bonded to the die in all of the PEDs. Aluminum bonding wires were ultrasonically bonded to the die in the ceramic packaged circuits. Glassivation for die protection was found on all of the circuits.

⁵ M. Jacques, "The Chemistry of Failure Analysis," Proceedings, 17th IEEE Reliability Physics Symposium, 1979.

All the decapsulated circuits were inspected with an optical microscope. The obvious failure mechanism of the PEDs was aluminum metal corrosion on the die.^{6,7,8} The greatest concentration of corrosion was found on the wire bonding pads where passivation is removed during processing of the circuits. (Aluminum corrosion of the intraconnects was found where glassivation pinholes or scratches existed.) Occasionally, some PEDs showed evidence of gold metal on the die surface caused by some of the gold bonding wire electroplating to the die surface under the influence of high moisture content and potential differences between bonding wires.

The ceramic packaged circuits were not tested for hermeticity before autoclave testing although it was assumed that most, if not all, were hermetic. Each package was hermeticity tested after the autoclave test and each was found to be a gross leaker. Leakage bubbles were visible from package areas where: (1) corrosion was on the Kovar cap; (2) the Kovar cap mated the package body; and (3) the alumina laminates (which make up the package body) mated. These sections are shown in an exploded package view (Fig. 2). The combination of high humidity and temperature in the autoclave accelerated the corrosion of the metal sections of these packages.

Failure analysis of the circuits in the ceramic packages showed two basic failure mechanisms. The most obvious failure mechanism was aluminum metal corrosion on the die. The other failure mechanism was corrosion of the metal on the package alumina laminate located between the external package leads and internal bonding wires. This package failure mechanism contributed substantially to the failure rates of two biased groups and was therefore included as a legitimate autoclave testing failure. The make-up of die and package failure mechanisms was:

	<u>DIE (%)</u>	<u>PACKAGE (%)</u>
A4 - with bias	90	10
A5 - with bias	31	69
A5 - no bias	100	0

The combination of moisture in the voids of the alumina laminates and an application of bias potentials on the leads resulted in galvanic corrosion of the metal with eventual electrical opens.

In several of the electrically biased ceramic packaged circuits, silver dendrites were visible on the die surface. Examination showed silver migration of the silver-filled epoxy die mounting material onto the die.

In Figures 2 through 5, the micrographs show various degrees of aluminum corrosion on some of the 4001-type circuits from the autoclave testing. These micrographs also show the wide range of vendor design layouts used for the circuit dice. Each vendor used his own layout and even these varied from older to newer date coded circuits. Only vendor B used the same layout for both date-coded circuits evaluated.

- 6 B. Reich, "Bias Influence on Erosion of Plastic Encapsulated Device Metal Systems", IEEE Trans. Rel. Vol. R-25, No. 5, December 1976.
- 7 S. C. Kolesar, "Principles of Corrosion," in Proc. 12th Annual IEEE Int. Reliability Physics Symposium, 1974.
- 8 H. Koelmans, "Metallization Corrosion in Silicon Devices by Moisture Induced Electrolysis", in Proc. 12th Annual IEEE Int. Reliability Physics Symposium, 1974.

To determine if the internal package leadframe design contributed to the overall moisture resistance reliability, radiographs of each vendor's package were taken and grouped by different style of lead frame. Figure 7 shows the styles of lead frames and vendors which used each type. Obviously, a majority of vendors used one style of lead frame, but the failure distribution data showed a wide range of results among vendors using the same style of lead frame. Therefore, it is concluded that the lead frame style has a negligible effect on the moisture resistance reliability of PEDs from different vendors.

FAILURE DATA DISTRIBUTIONS

Each vendor's test data was plotted on Weibull probability graphs and failure distributions were determined for each group. The Weibull graph is a plot of cumulative percent failure versus total test time. Appendix A shows a Weibull probability graph for each vendor group. From the Weibull graphs, the median life in hours, shape parameter or slope of the curve and the correlation coefficient of each curve was determined. In Table 3, this information is tabulated for the vendor groups which were biased at 5 volts in the autoclave. Table 4 contains the tabulated information for the unbiased groups. The consistently high correlation coefficients support the validity of applying the Weibull distribution to the test data.

In general, for the biased autoclave test, each vendors' newer date coded PEDs had longer median life times than older date coded parts by factors of 2 to 3. The only exception to this observation was vendor E whose PEDs had relatively similar median life times, regardless of date code. These life times were longer than most from the other vendors.

For each vendor, the unbiased autoclave tested PEDs had longer median life times than the corresponding groups biased in the autoclave by factors of 1.9 to greater than 8.5. The ranges of median lifetimes between vendors in the autoclave tests precluded the generation of an acceleration factor between biased and unbiased autoclave tests for the PEDs. For example, vendor D's circuits had the longest median life (360 hours) with bias and only average median life (670 hours) with no bias, giving an acceleration factor of 1.9. Vendor A3, on the other hand, had circuits with the longest median life (1200 hours) with no bias and only average median life (140 hours) with bias, giving an acceleration factor of 8.6.

The shape parameter, which is the slope of the Weibull curve, is a useful parameter because it gives a direct indication of the failure distribution. Shape parameters of <1.0 indicate dominant early-failures by parts having a high proportion of weak or marginal devices. Shape parameters of >1.0 indicate a wearout behavior by parts that fail within a short time span. The importance of the shape parameter is reflected by the results of vendor B. This vendor was the only one to use the same style die for both the older (B1) and newer (B2) date-coded parts. The data distributions for the biased autoclave test shows that the shape parameter changed from 0.7 to 5.5 with a corresponding increase in median life from 55 to 110 hours. This substantial effect on the shape parameter was promoted by a simple change of plastic encapsulant from silicone to an

epoxy mixture. This was the only major change between the lots determined during the failure analysis. The shape parameters ranged from 0.7 to 5.6 with an overall mean of 2.5 for the PEDs with bias and from 2.0 to 5.4 with an overall mean of 3.0 for the PEDs with no bias.

For potential applications in field equipment, both the biased and unbiased autoclave tests supply information for evaluating the moisture resistance of a vendor's PED. The biased test would help evaluate devices used in continuously operated equipment. The unbiased test would help evaluate devices used in inactive (stored) equipment. Thus, the anticipated field use would determine which test conditions could best evaluate the device's moisture resistance reliability.

Even though the ceramic packaged circuits were tested as control groups, several unexpected results occurred. In the biased test, the 7426 date-code group had a median life which was twice as long as the 7544 date-code group. This difference was due to a poorer quality of package used for the 7544 date code group. The failure analysis revealed this fact by the large percentage of package metallization failures found in this group. In the biased test, the ceramic package group with the 7426 date codes had longer median lifetimes than did the earlier and most of the latter date coded PEDs.

In the non-biased test, the median life of the ceramic packaged circuits was based on 30% population failures, which could only be considered as "freak failures." The remaining 70% of the devices were still good after more than 3700 hours in the autoclave test. Using the "freak failure" population distribution, these circuits had a median lifetime more than twice the time of the best group of PEDs.

CONCLUSIONS

Failure analysis showed aluminum metal corrosion on the die to be the only failure mechanism found for all of the PEDs on test. Most of the corrosion was located on the bonding pads where the die glassivation had been removed, but some corrosion was also visible where pinholes or scratches occurred in the glassivation.

A large number of ceramic package failures were due to corrosion of the package interconnect metal and from corrosion induced holes in the Kovar caps.

A general improvement of moisture resistance reliability for PEDs in the biased test was indicated by the longer median life times of the newer over the older groups. It was also shown that a non-biased autoclave test of PEDs gives median lifetimes from 2 to greater than 8.5 times longer than their counterpart PEDs in the biased test. An acceleration factor between the biased and unbiased tests could not be determined for the PEDs as a group, but only for each particular vendor's product.

The anticipated PED field use is important in determining which tests should be performed to best evaluate a vendor's product for moisture resistance.

The results of the short term autoclave test program and the Panama field test program will be used to develop acceleration factors which will be used to predict operational reliability.

The ceramic packaged circuits were clearly better than any of the PED groups for moisture resistance in both the biased and unbiased tests. A change in the design of the ceramic packages to eliminate the type of package failures found in the failure analysis would result in even better moisture resistance capabilities.

Table 1. 4001 CMOS Autoclave Test Matrix

<u>VENDOR</u>	<u>PART NUMBER</u>	<u>PACKAGE DATE CODES</u>	<u>BIAS TEST</u>	<u>UNBIASED TEST</u>
A1	CD4001 AE	7435	X	X
A2	CD4001 AE	7605	X	
A3	CD4001 BE	7711	X	X
A4	CD4001 AD	7426	X	
A5	CD4001 AD	7544	X	X
B1	SCL4001 AE	7410	X	
B2	SCL4001 A/BE	7701	X	X
C1	MC14001 CP	7421, 7444	X	
C2	MC14001 B	7709	X	X
D1	34001 PC	7415	X	
D2	F4001 PC	7705	X	X
E1	SIL4001 AE	7429, 7431	X	
E2	SIL4001 BE	7646	X	X
F1	CD4001 AE	7424, 7431, 7433	X	
F2	CD4001 BCN	7711	X	X
G	CM4001 AE	7324, 7334, 7402	X	
H	SW4001 AE	7443	X	
I	CD4001 BE	7706	X	X
J	TC4001 P	7640	X	X

Table 2. Physical Dimensions

<u>VENDOR</u>	<u>PACKAGE ENCAPSULANT</u>	<u>BONDING WIRE DIAMETER (μm)</u>	<u>DIE DIMENSIONS (mm)</u>
A1	Epoxy	30.5	1.51 x 1.48
A2	Epoxy	30.5	1.51 x 1.48
A3	Epoxy	25.4	2.12 x 1.71
A3	Ceramic	38.1	1.51 x 1.48
A5	Ceramic	38.1	1.51 x 1.48
B1	Silicone	30.5	1.55 x 1.15
B2	Epoxy	25.4	1.55 x 1.15
C1	Epoxy	30.5	1.71 x 1.56
C2	Epoxy	28.2	1.57 x 1.39
D1	Epoxy	17.8	1.31 x 1.26
D2	Epoxy	25.4	1.35 x 1.35
E1	Epoxy	17.8	1.61 x 1.23
E2	Epoxy	25.4	1.79 x 1.54
F1	Epoxy	17.8	1.46 x 1.03
F2	Epoxy	25.4	1.62 x 1.15
G	Epoxy	25.4	1.60 x 1.60
H	Epoxy	25.4	2.26 x 1.84
I	Epoxy	25.4	1.58 x 1.58
J	Epoxy	25.4	1.80 x 1.71

Table 3. Weibull Distributions for 5 Volt Bias Autoclave Test

<u>VENDOR</u>	<u>MEDIAN LIFE (HOURS)</u>	<u>SHAPE PARAMETER</u>	<u>CORRELATION COEFFICIENT</u>
A1	78	--	--
A2	180	2.1	0.94
A3	140	1.6	0.99
A4	270	4.1	0.98
A5	120	1.4	0.98
B1	55	0.7	0.88
B2	115	5.5	0.99
C1	50	1.7	0.99
C2	140	2.8	0.97
D1	120	3.8	0.95
D2	360	2.7	0.98
E1	200	2.1	0.96
E2	180	3.2	0.98
F1	120	1.1	0.97
F2	300	1.9	0.96
G	95	1.3	0.96
H	145	2.7	0.96
I	95	3.1	0.97
J	70	5.6	0.96

Table 4. Weibull Distributions for No Bias (Storage) Autoclave Test

<u>VENDOR</u>	<u>MEDIAN LIFE (HOURS)</u>	<u>SHAPE PARAMETER</u>	<u>CORRELATION COEFFICIENT</u>
A1	220	4.1	1.00
A3	1200	3.7	0.97
A5	2200	1.9	0.86
B2	620	5.4	0.89
C2	380	2.1	0.88
D2	670	2.1	0.99
E2	700	2.1	0.97
F2	950	2.0	0.85
I	280	2.8	0.98
J	620	2.1	0.97

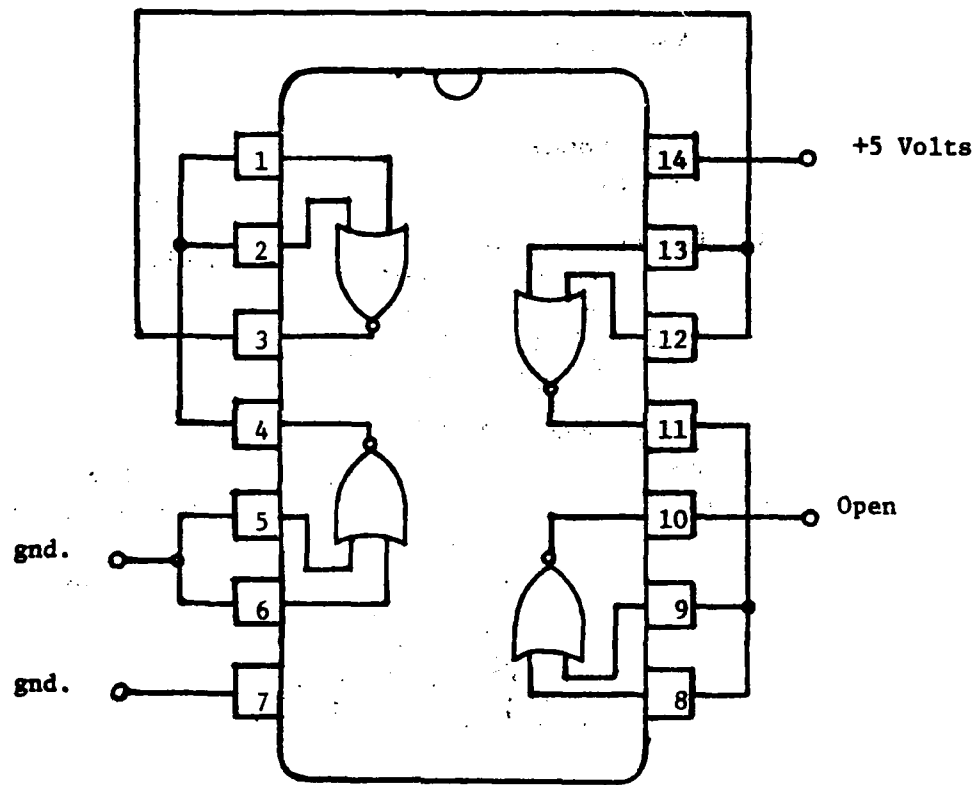

Figure 1. Electrical Bias in Autoclave

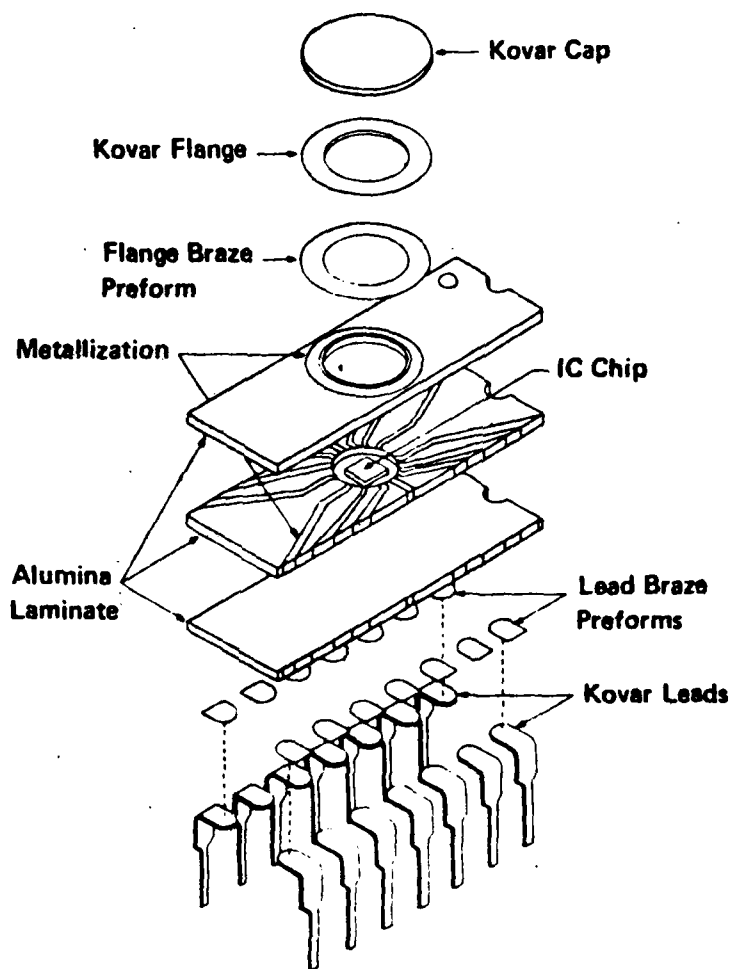
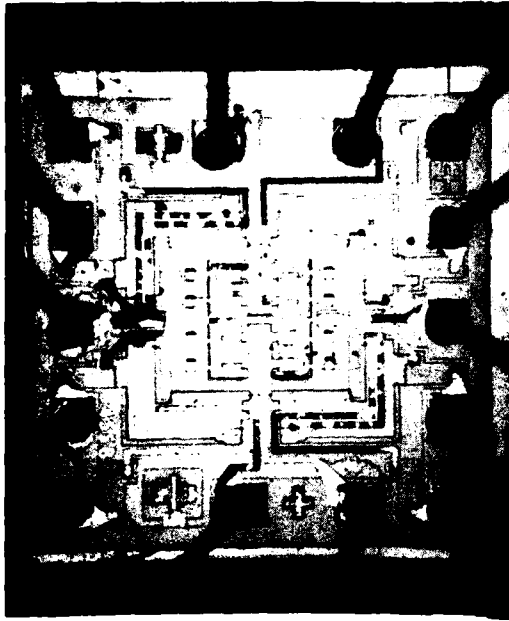
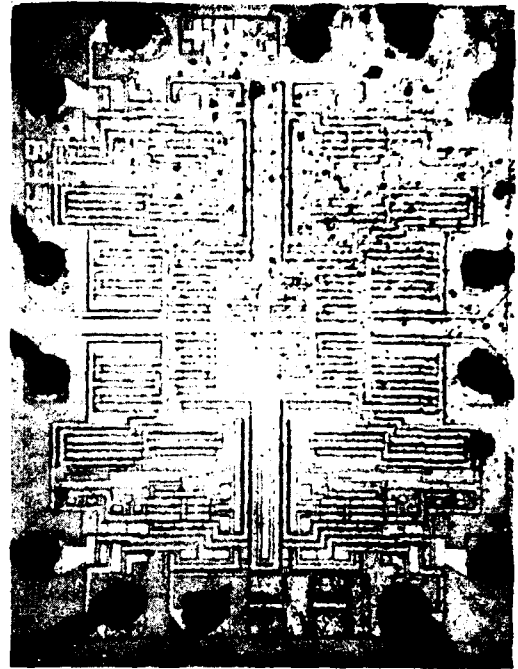

Figure 2. An exploded view of the ceramic packages



A1, A2
Type A2 biased for 240 hours



Type A3 unbiased for 3792 hours

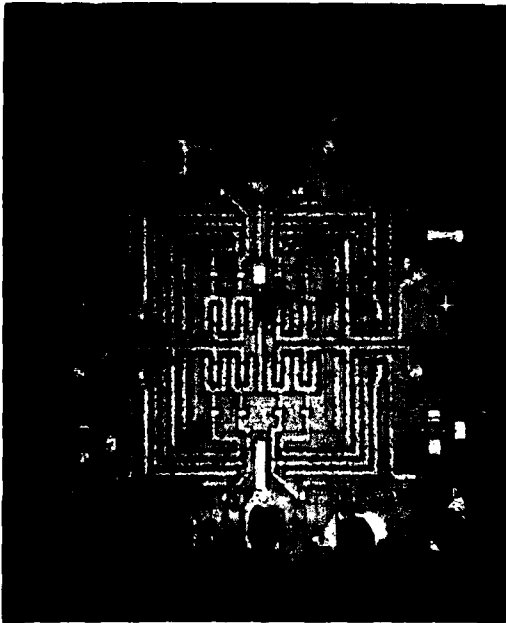

A4, A5
Type A4 biased for 288 hours

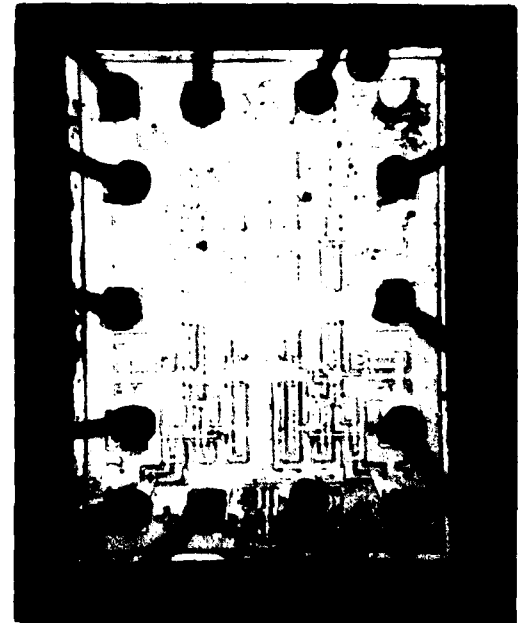

B1, B2
Type B2 unbiased for 552 hours

Figure 3. Micrographs of Type 4001 die from vendors A and B.



Type C1 biased for 96 hours

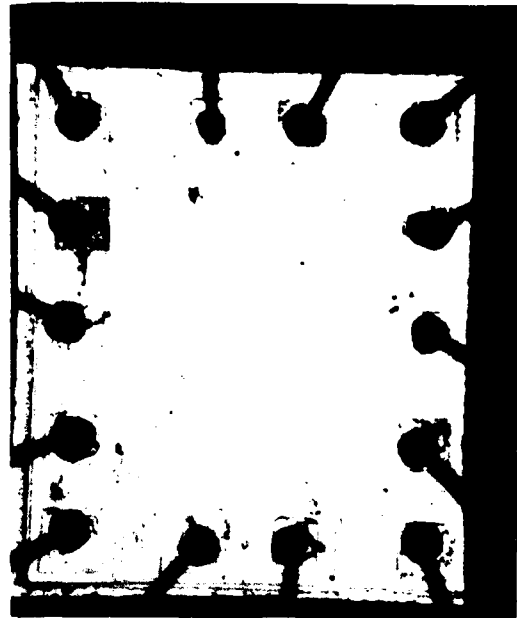

Type C2 biased for 144 hours

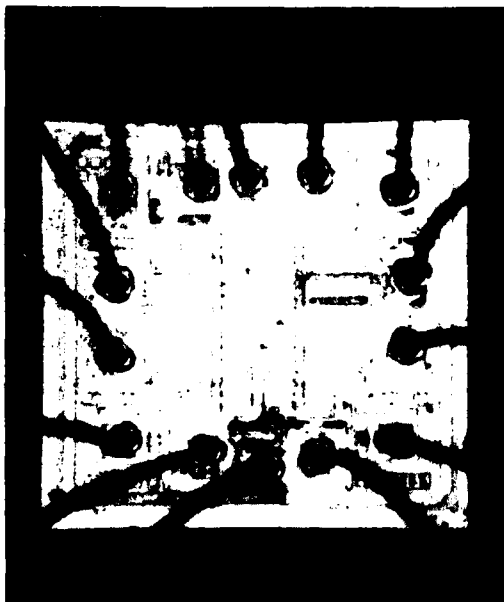

Type D1 biased for 120 hours

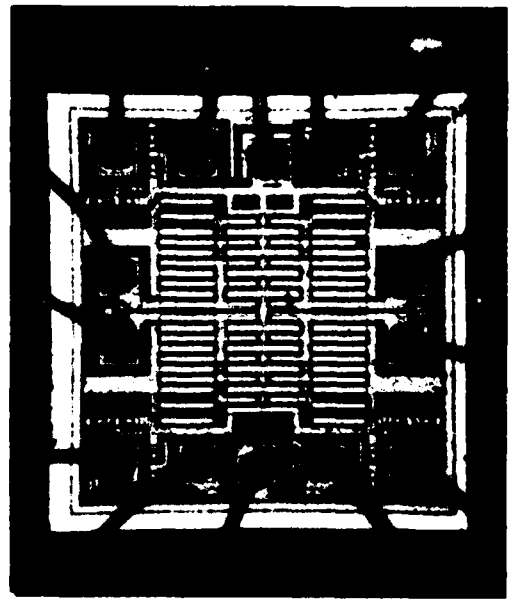

Type D2 unbiased for 1008 hours

Figure 4. Micrographs of Type 4001 die from vendors C and D.

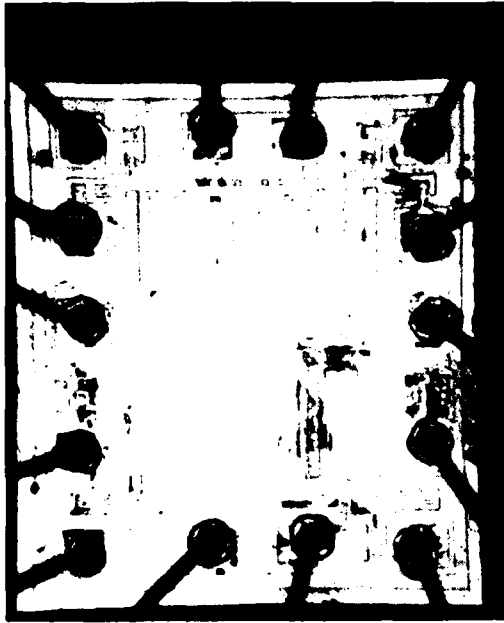

Type E1 biased for 144 hours

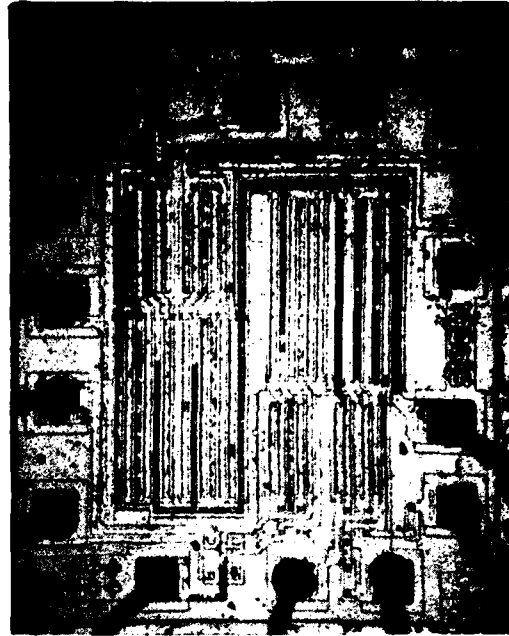

Type E2 biased for 96 hours

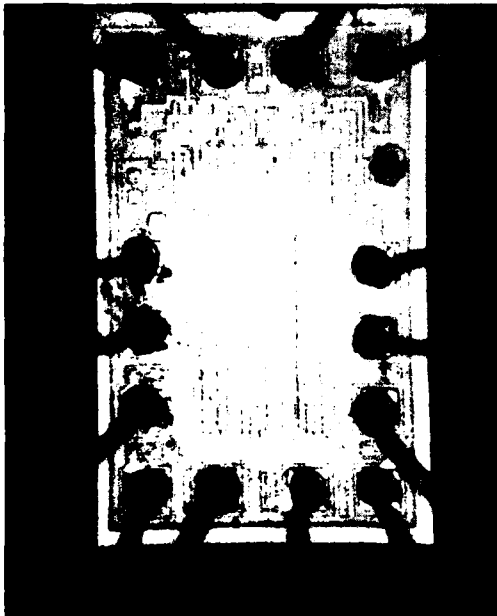

Type F1 biased for 288 hours

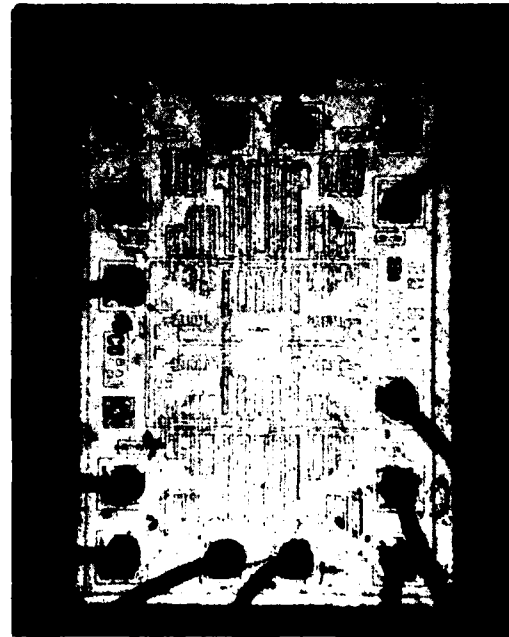

Type F2 unbiased for 2792 hours

Figure 5. Micrographs of Type 4001 die from vendors E and F.

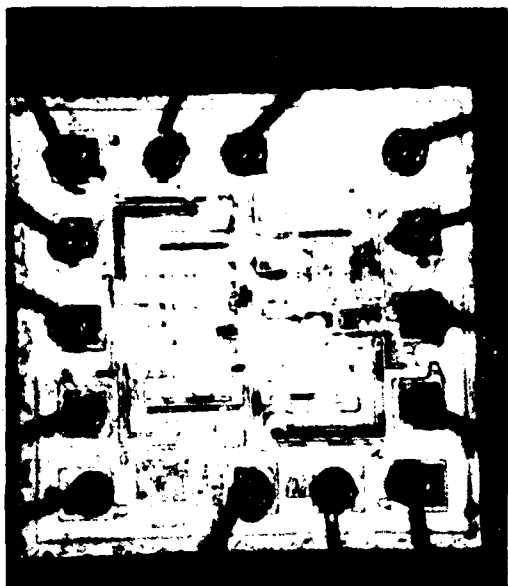

Type G biased 96 hours

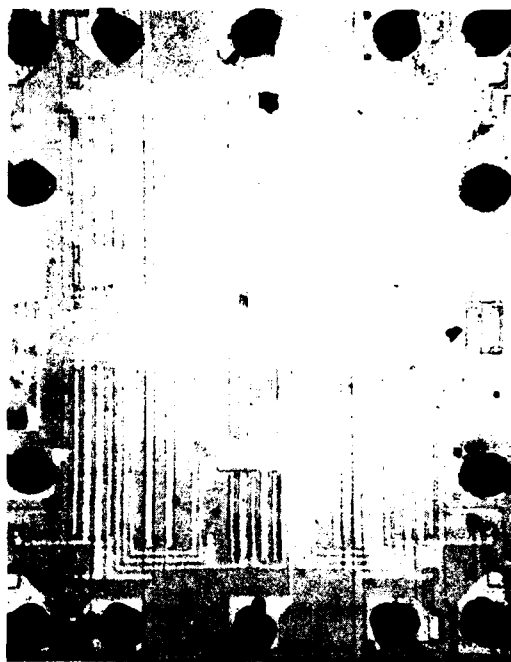

Type H biased 216 hours

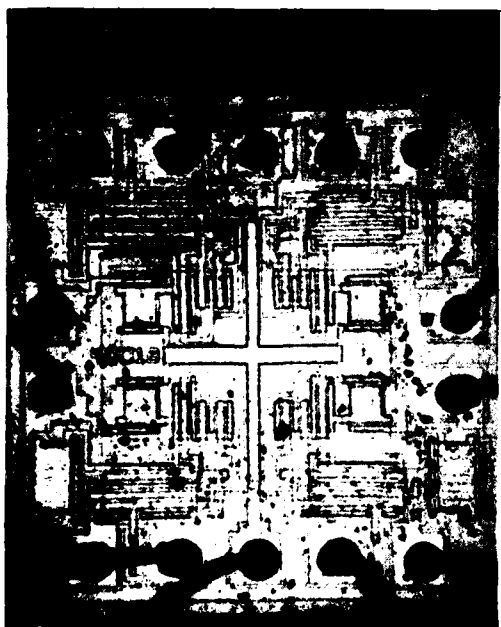

Type I unbiased 168 hours

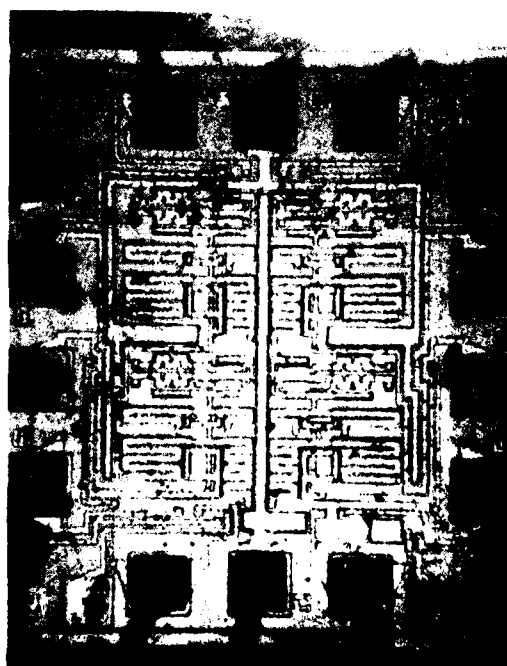

Type J unbiased 408 hours

Figure 6. Micrographs of Type 4001 die from vendors G, H, I and J



A1
A2
A3
B2
C2
E1
E2
F1
F2
H

A4
A5

B1

C1



D1
D2

G

I

J

Figure 7. Radiographs of the different package styles tested.

APPENDIX A

WEIBULL PROBABILITY DISTRIBUTIONS

1. Vendor A
2. Vendor A - Ceramic Package
3. Vendor B
4. Vendor C
5. Vendor D
6. Vendor E
7. Vendor F
8. Vendors G and H
9. Vendors I and J

