

18) Report No. 19 FAA-EM-79-19	2. Government Accession No.	3. Recipient's Catalog No.
6) Potential Benefits of the Use of Separate Short Runways at Major Airports,		11) Report Date September 1979
10) Author(s) Frank A./Amodeo Steven E./Koenig Performing Organization Name and Address The MITRE Corporation Metrek Division 1820 Dolley Madison Blvd. McLean, VA 22102		14) Performing Organization Report No. MTR-79W00374 10) Work Unit No. (TRAIS) 11) Contract or Grant No. DOT-FA79WA-4184
12) Sponsoring Agency Name and Address Department of Transportation Federal Aviation Administration Office of Systems Engineering Management Washington, DC 20591		13) Type of Report and Period Covered 14) Sponsoring Agency Code AEM-100
15) Supplementary Notes <div style="text-align: right; border: 1px solid black; padding: 5px; display: inline-block;"> 12) 53 </div>		
16) Abstract <p>The use of separate short runways for general aviation, commuter air carrier and air taxi operations, where possible, may provide increased airport capacity and hence reduced delays. These reduced delays would benefit the airport users through lower operating expenses. The purpose of this analysis is to investigate the top thirty air carrier airports for the potential utilization of new or existing short runways under IFR conditions, and to estimate the potential IFR delay savings that would result from this use.</p>		
17) Key Words Airport Capacity, Short Runway, Commuter, General Aviation, Aircraft Delay	18) Distribution Statement Document is available to the public through the National Technical Information Service, Springfield, VA 22161	
19) Security Classif. (of this report) Unclassified	20) Security Classif. (of this page) Unclassified	21) No. of Pages 22) Price

409890

DM

PREFACE

The purpose of this report is to present the results of a first order analysis of the potential benefits of the use of separate short runways at the top 30 major air carrier airports. Detailed analysis of each of the 30 airports was beyond the scope of this effort. Some of the generalized assumptions made in this analysis may differ from other site specific studies directed toward specific airports. As a result, numerical estimates of capacities and delays presented here may not exactly coincide with those of the site specific studies. However, the order of magnitude of the estimates and the range of potential benefits are consistent with other studies conducted through Airport Improvement Task Forces (consisting of airport sponsors, airlines, ATA and FAA) at some of the major airports.

Accession For	
NTIS GFA&I	<input checked="" type="checkbox"/>
DDC TAB	<input type="checkbox"/>
Unannounced	<input type="checkbox"/>
Justification	<input type="checkbox"/>
By _____	
Date _____	
Agency _____	
Dist. _____	
A	

ACKNOWLEDGEMENTS

The authors are grateful to Prof. Amedeo Odoni and Mr. John Pararas of M.I.T. for providing the many computer runs of the M.I.T. "DELAYS" program. The future daily demand profiles for the candidate airports were developed by Mr. John Garner of MITRE.

CONCLUSIONS AND RECOMMENDATIONS

Delay savings, under IFR conditions, due to an increase in capacity through the use of a separate short runway appear to be attainable at 11 out of the top 30 air carrier airports. Of these 11 airports, three would use existing short runways which are presently not utilized under IFR conditions, two would require the extension of existing short runways to a length of 4000 feet, and six would require the construction of new short runways.

Average IFR delay savings, in minutes per operation, vary from airport to airport to a maximum of over 30 minutes, using conservative demand profiles.

Total discounted IFR delay savings (in 1980 dollars with a 10% discounting rate) over the 1980 to 1990 time frame, for all 11 candidate airports range from about \$450 million to about \$810 million depending on the traffic level. Of this, \$400M to \$700M will be saved by air carriers, and \$50M to \$110M will be saved by the commuter, air taxi and general aviation communities.

The analysis concerned itself with potential benefits only construction and maintenance costs for new runways were not estimated. Although the total savings across the 11 airports are estimated to be quite large, these savings are by no means evenly distributed over all airports. Chicago, Atlanta and Philadelphia account for 70% to 77% of the total benefits. Almost 99% of the benefits are accounted for with the addition of Dallas-Ft. Worth, Kennedy, Denver, and St. Louis. In order to evaluate the worthiness of the proposed runway at each airport one would have to estimate, in addition to any construction and maintenance costs, the cost of the additional operational complexity required to segregate traffic and provide an additional approach stream. It is unlikely that all candidate runways would yield an attractive benefit/cost ratio. However, the analysis indicates that there are substantial benefits to be realized at particular airports and that a more detailed investigation of some of the more promising airports should be undertaken.

TABLE OF CONTENTS

	<u>Page</u>
1. INTRODUCTION	1-1
1.1 Background	1-1
1.2 Objective	1-1
1.3 General Assumptions	1-1
2. METHODOLOGY	2-1
2.1 Criteria for Selection of Candidate Runways	2-1
2.2 Capacity Estimation	2-3
2.3 Demand Projection	2-3
2.3.1 Full Demand Profiles	2-4
2.3.2 Modified Demand Profiles	2-5
2.4 Delay Estimation	2-5
2.5 Delay Reduction Benefits Estimation	2-6
3. RESULTS	3-1
3.1 Selection of Candidate Runways	3-1
3.2 Capacity Estimates	3-1
3.3 Delay Estimates	3-8
3.4 Savings Estimates	3-8
4. CONCLUSIONS AND RECOMMENDATIONS	4-1
APPENDIX A: PARAMETERS USED IN THE ANALYSIS	A-1
A.1 Inputs to the Capacity Model	A-1
A.2 Demand Profiles	A-1
A.3 Weather and Configuration Utilization Data	A-1
APPENDIX B: REFERENCES	B-1

LIST OF ILLUSTRATIONS

	<u>Page</u>
TABLE 2-1: THE TOP 30 AIR CARRIER AIRPORTS	2-2
TABLE 2-2: AVERAGE 1980 OPERATING EXPENSE BY AIRCRAFT CLASS	2-7
TABLE 3-1: CONFIGURATIONS WITH AND WITHOUT THE SEPARATE SHORT RUNWAY	3-9
TABLE 3-2: AIRPORT CAPACITIES FOR THE CANDIDATE AIRPORTS	3-10
TABLE 3-3: AVERAGE DELAY PER OPERATION FOR THE CANDIDATE AIRPORTS - FULL DEMAND	3-11
TABLE 3-4: AVERAGE DELAY PER OPERATION FOR THE CANDIDATE AIRPORTS - MODIFIED DEMAND	3-12
TABLE 3-5: ANNUAL SAVINGS AT CANDIDATE AIRPORTS	3-14
TABLE 3-6: DISCOUNTED SAVINGS AT CANDIDATE AIRPORTS	3-15
TABLE A-1: AIRCRAFT MIXES	A-2
TABLE A-2: AIRPORT SPECIFIC PARAMETERS	A-3
TABLE A-3: AIRPORT INDEPENDENT PARAMETERS	A-5
TABLE A-4: WEATHER AND CONFIGURATION USE DATA	A-17
FIGURE 3-1: AIRPORT LAYOUTS	3-2
FIGURE A-1: DEMAND PROFILES FOR ORD	A-6
FIGURE A-2: DEMAND PROFILES FOR ATL	A-7
FIGURE A-3: DEMAND PROFILES FOR DFW	A-8
FIGURE A-4: DEMAND PROFILES FOR JFK	A-9
FIGURE A-5: DEMAND PROFILES FOR DEN	A-10
FIGURE A-6: DEMAND PROFILES FOR PIT	A-11
FIGURE A-7: DEMAND PROFILES FOR STL	A-12

LIST OF ILLUSTRATIONS
(Concluded)

	<u>Page</u>
FIGURE A-8: DEMAND PROFILES FOR DTW	A-13
FIGURE A-9: DEMAND PROFILES FOR PHL	A-14
FIGURE A-10: DEMAND PROFILES FOR IND	A-15
FIGURE A-11: DEMAND PROFILES FOR PDX	A-16

1. INTRODUCTION

1.1 Background

Air travel forecasts for the next decade indicate the requirement for additional capacity at many of the nation's airports. Construction of long runways suitable for use by air carriers is often impossible because of lack of space on the airport grounds or adjacent land. Construction of shorter runways suitable for general aviation, commuter air carrier and air taxi type aircraft may be possible at particular facilities where longer runways are not able to be constructed. These short runways may provide a significant increase in capacity at the candidate airports.

For each configuration, the amount of increased capacity resulting from the utilization of a separate short runway for general aviation, commuter air carrier and air taxi operations is dependent upon the aircraft mix at the airport and the amount of separation between the short runway and other runways which are used simultaneously. An increase in capacity will reduce the delays and operating costs of all users of the airport, not just those that are able to use the short runway.

1.2 Objective

The objective of this analysis is to provide first order estimates of the potential savings in operating expenses due to reduction in IFR delays, if separate short runways are used, where possible, for general aviation and air taxi operations.

1.3 General Assumptions

Certain assumptions or ground rules were established in the course of the analysis and these are mentioned briefly below. They are treated in more detail in subsequent sections.

- The analysis was limited to the top 30 air carrier airports. It was felt that almost all of the potential benefit would exist within this group.
- Proposed short runways which were considered were of a minimum length of 4000 to 4500 feet in order to accommodate some of the larger equipment used by the commuter and air taxi community.

- Delay reduction benefits were claimed only for IFR operations under CAT I conditions. A CAT I ILS or MLS was assumed for the proposed short runway.
- Existing ATC rules were assumed.
- Both parallel and intersecting runways were considered. However, parallel configurations were preferred due to their higher benefits (in most cases) and their less complex airspace structure.
- A time period of 1980 to 1990 was analyzed.

2. METHODOLOGY

2.1 Criteria for Selection of Candidate Runways

The initial group of airports considered in this analysis was obtained by selecting the top thirty airports in the country, in terms of air carrier operations for Calendar Year 1976* (Reference 1). A listing of these airports is given in Table 2-1. The reason for choosing this group of airports is that most of the delay experienced by the users of the nation's airports occurs at these facilities. It is the reduction in this delay that is seen as the potential benefit of the utilization of separate short runways for general aviation, air taxi, and commuter air carrier operations.

It was assumed that a runway dedicated to the operators of small aircraft must be a minimum of 4000 feet in length, in order to accommodate some of the larger equipment used by the commuter air carrier and air taxi community. Prime consideration was given to runway candidates which would allow independent parallel operations in IFR conditions (4300 feet minimum separation between runways) as this would yield maximum capacity benefits. Less desirable alternatives with smaller potential benefits were dependent parallel runways (minimum separation of 700 feet) and intersecting runways. Intersecting runways were considered only for those cases where intersecting pavement already existed and where parallel alternatives were not possible.

The investigation of candidates was not limited to existing runways. Consideration was given to possible extension and/or revitalization of shorter runways, taxiways, and decommissioned runways. Construction of a new runway was always a potential alternative and in fact was favored in those cases where a new short runway promised to give higher capacity benefits than an existing runway.

The main reference used in determining the availability and feasibility of a potential runway was the FAA Form 1010-1 "Airport Master Record." In a few cases the detail presented on these forms was not sufficient to make informed judgments in which case a review was made of the Airport Master Plans on file at the FAA Headquarters. While in some cases a candidate runway was excluded on the basis of known obstructions, a detailed

*More recent data changes the list of the airports slightly in the last few airports. These changes do not have any significant impact on the analysis presented here.

TABLE 2-1

THE TOP 30 AIR CARRIER AIRPORTS

<u>AIRPORT NAME</u>	<u>AIRPORT CODE</u>
Chicago O'Hare International	ORD
Atlanta International	ATL
Los Angeles International	LAX
Dallas-Ft. Worth Regional	DFW
John F. Kennedy International	JFK
La Guardia	LGA
San Francisco International	SFO
Denver Stapleton International	DEN
Miami International	MIA
Boston Logan International	BOS
Washington National	DCA
Greater Pittsburgh International	PIT
St. Louis International	STL
Detroit Metro Wayne Co.	DTW
Philadelphia International	PHL
Minneapolis-St. Paul International	MSP
Newark International	EWR
Houston Intercontinental	IAH
Cleveland Hopkins International	CLE
Seattle-Tacoma International	SEA
Kansas City International	MCI
Tampa International	TPA
Memphis International	MEM
Honolulu International	HNL
Las Vegas McCarran International	LAS
New Orleans International	MSY
Phoenix Sky Harbor International	PHX
Indianapolis International	IND
Greater Cincinnati	CVG
Portland International	PDX

inspection of potential obstructions was not possible with the available data. An in-depth study of selected airports is required. A site specific study for Denver has been initiated (Reference 2). Questions pertaining to obstruction clearance and airspace structure will be addressed in this subsequent analysis.

2.2 Capacity Estimation

Capacity estimates were obtained for each of the candidate airports, i.e., airports that exhibited the potential for capacity increase. The MITRE Capacity Model (Reference 3) was used to calculate these capacities. Capacities were estimated for all configurations which would utilize the short runway, for both the case that includes the separate short runway and for the case that does not. Aircraft mixes for both 1980 and 1990 were used and these mixes were derived as follows. Aircraft are defined to be included in one of the following four aircraft classes, according to the maximum gross takeoff weight (GTOW):

S (small) $GTOW \leq 12,500$ lb.

L₁ (large) $12,500$ lb. $< GTOW \leq 90,000$ lb.

L₂ (large) $90,000$ lb. $< GTOW < 300,000$ lb.

H (heavy) $300,000$ lb. $\geq GTOW$

Projected annual operations, broken down into general aviation, air taxi and air carrier, were obtained from Reference 4. Forecasted air carrier equipment by operation was obtained from Reference 5. Air taxi equipment was assumed to be 25% class S and 75% class L₁ (by operation). General aviation equipment was assumed to be composed entirely of Class S equipment. The actual mixes used in the analysis are given in Appendix A along with the other input data needed to calculate capacity. Current ATC regulations (interarrival separation standards, required runway separation, etc.) for IFR weather were assumed.

2.3 Demand Projection

The average delay per aircraft, for a given configuration, is dependent not only on the capacity of the particular configuration, but also on the demand for service at the airport. Demand plays a dual role in the determination of average delay, since the average delay per aircraft is a function of both the total volume of demand and the distribution of this demand throughout the day. For each airport, the total daily demand was obtained by dividing the projected annual operations (taken from Reference 4) by 365, and so the daily demand corresponds to an average day. This was done for both 1980 and 1990 forecasts.

Two different sets of hourly demand profiles were constructed, as a way of addressing the question of how demand would redistribute itself in response to increased delays during peak hours. One set of profiles assumed no redistribution of demand, and was obtained by expanding today's profiles (Reference 6) to account for the increased levels of forecasted traffic. This assumes that today's profiles reflect the desire of the various segments of the aviation community to arrive and depart at particular hours. However, as delays at particular hours increase because of increased demand during those hours, the economic penalty of incurring large delays will cause a certain amount of traffic to elect to fly into or out of the airport during the less busy hours. This will result in a demand profile which is flatter than that which is observed today. In the extreme cases where large delays exist throughout the day, part of the traffic will divert to alternate, less busy airports. A second set of demand profiles was developed to account for this phenomenon.

In the analysis both sets of demand profiles were used, and this enabled conceptual upper and lower bounds to be obtained for the values of average delay under a particular scenario. Full projected demands provide conceptual upper bounds since the cost of delay is greater than the perceived value of flying into or out of the particular facility during the favored hours or using that airport as opposed to an alternate facility. Modified demand profiles provide a conceptual lower bound since the resulting delay costs do not account for the value of the rejected demand. The ability to regard these numbers as bounds is dependent upon the assumption that the delays under the full demand scenarios are unacceptable while the delays under the modified demand scenarios are acceptable.

2.3.1 Full Demand Profiles

Hourly demand profiles were obtained by taking the profiles provided by Reference 6 and expanding them as follows. The air carrier profile was expanded (operations for each hour were multiplied by a constant) such that the total for the day was equal to the average daily number of air carrier operations. The profile for air taxi was expanded to account for the forecasted traffic for both air taxi and general aviation. It was necessary to use the air taxi profile for general aviation because profiles are not available for general aviation. The resulting profiles, derived for 1980 and 1990 levels of forecasted traffic, assume that the relative degree of peaking, i.e., the proportion of traffic occurring during each hour of the day, will not change in the future as a result of increased demand and increased delay.

2.3.2 Modified Demand Profiles

A set of heuristic rules was developed to enable modified demand profiles to be constructed. Although it is the delay experienced by the airport users that motivates demand redistribution, the problem can be thought of in terms of demand responding to available capacity. The desire to avoid running the delay model (described in the next section) many times in an iterative fashion dictated that the heuristic algorithm concern itself only with the hourly demand and the available capacity. Prior experience demonstrated that if hourly demand was limited to be only slightly greater than hourly capacity, reasonable values would be obtained for the expected average delay. A busy period was defined as the 16 hours from 0700 to 2300 hours. The general rule was established that for each hour in the 16 hour busy period, demand could exceed capacity by an amount equal to $1/16$ of one hour's capacity. Excess demand (the amount above $17/16 \times$ capacity) above this demand threshold for specific hours was redistributed to other less busy hours within the 16 hour period.

In some cases, projected 16 hour demand exceeded the limit imposed by the algorithm ($17 \times$ hourly capacity). In these cases, excess demand was discarded, implying diversions to alternate airports. The resulting modified demand profile was one level, 16 hour peak with demand equal to the limit. Demand in the 8 hours outside the busy period was not changed. The capacity values used to calculate the hourly demand limit correspond to the configurations without the separate short runway and for IFR weather which would give a lower estimate of the associated benefits.

2.4 Delay Estimation

Estimates of average delay per aircraft were obtained using an analytical model, the MIT "DELAYS" Model (Reference 7). Input to the model consists of hourly capacity and the 24 hour demand profile, as well as a parameter describing the number of independent runways. The analysis was restricted to IFR operations under CAT I conditions and hence no delay reduction benefit was claimed for VFR weather. Total delay was obtained by multiplying the resulting average delay values by the forecasted annual operations, the historical utilization of the particular configuration, and by the proportion of IFR weather at each facility (Reference 8). While IFR weather is defined to be ceiling below 1000 feet and/or visibility less than 3 nmi, due to the format of the data in Reference 8 it was assumed for this analysis that IFR weather was ceiling/visibility less than

1500 feet/3 nmi. Obtaining delay estimates for full IFR days and multiplying by the proportion of IFR weather may yield slightly higher estimates of average delay than would occur if the delay estimation procedure had assumed that particular days had IFR weather during some hours and VFR weather during other hours. This would require detailed weather data or further assumptions concerning the weather distribution. It is expected that this effect is countered by not claiming any delay benefit for VFR weather, and by using demand profiles corresponding to average days.

2.5 Delay Reduction Benefits Estimation

Delay savings estimates are obtained by taking the difference in expected delay per operation between the two cases: with and without the separate short runway. Based upon the small amount of delay difference on a per operation basis, only flying and maintenance cost factors were applied to convert minutes of delay to dollar values. Flying costs include flight and cabin crew, fuel and oil, and insurance. Maintenance expense includes direct costs and burden for both airframes and engines. Aircraft depreciation, aircraft rentals, and passenger travel time were not included since small quantities of time saved can seldom be profitably utilized by those factors.

Cost per block hour information by aircraft type is compiled as part of the Form 41 data published by the CAB (Reference 9). That source lists flight crew costs but does not include cabin crew outlays. Information from informal CAB sources indicated domestic trunk cabin crew expense averaged \$28-29 per attendant per block hour in 1976 dollars (Reference 10). These costs were included for those aircraft types that were applicable.

To obtain operating costs in 1980 dollars, the 1976 costs, calculated as described above, were multiplied by a factor of 1.27 in order to account for inflation. The factor of 1.27 was determined from Reference 11 and represents a calculated inflation rate between 1976 and 1978 and a forecasted inflation rate between 1978 and 1980.

Average operating costs by aircraft class, presented in Table 2-2, were calculated by developing airport-specific, weighted average cost estimates for each class based upon projected aircraft type totals. The average expense estimates were then combined with the projected mixes for 1980 and 1990 to yield

TABLE 2-2

AVERAGE 1980 OPERATING EXPENSE BY AIRCRAFT CLASS
 (FLYING AND MAINTENANCE COSTS ONLY)

<u>CLASS</u>	<u>WEIGHT*</u>	<u>AVG. OPERATING COST PER MINUTE (1980 \$)</u>
Small (S)	≤12,500 lbs.	\$ 3.81
Large (L ₁)	12,500-90,000 lbs.	\$ 9.84
Large (L ₂)	90,000-300,000 lbs.	\$19.69
Heavy (H)	≥300,000 lbs	\$40.32

*Maximum Gross Takeoff Weight

delay cost factors in dollars per minute of delay for each facility. Each airport's forecasted delay per operation value was then converted to delay cost. The estimated delay expenses were computed only for the two end years. Linear interpolation was used for the intermediate data points between 1980 and 1990.

To obtain total costs or savings over the 11 year time frame, all costs for each year were discounted to 1980 values at a rate of ten percent per year (Reference 12).

3. RESULTS

3.1 Selection of Candidate Runways

The initial review of the 30 airports considered found that nine airports (BOS, DCA, EWR, HNL, LAX, MIA, MSP, MSY and PHX) could not accommodate separate short runways. These airports were eliminated from further consideration for one or more of the following reasons:

- a) the existing or proposed short runway is separated by less than 700 feet from an existing runway
- b) limited airport space or natural events such as flooding prohibited any further runway construction
- c) the use of existing or proposed short runways would not be compatible with currently used IFR configurations
- d) the only candidate configuration would add an existing runway which is long enough to handle air carrier operations. The increase in capacity would be similar in concept to constructing a new long runway or adding an ILS to an existing unused runway. Since this benefit would not be the result of a short runway, no such benefit was claimed.

3.2 Capacity Estimates

In the initial stages of capacity modeling it was found that 700 feet lateral separation between parallel runways was not sufficient to provide any capacity benefits. Due to the various rules governing interarrival, arrival-departure and departure-arrival separations, a minimum separation of 2500 feet (with corrections made for staggered runways) between parallel runways is required for any improvement in IFR capacity under today's lateral vortex rules. Another ten airports were eliminated from consideration because there was no capacity benefit due to the separate short runway. The ten airports eliminated from consideration were CLE, CVG, IAH, LAS, LGA, MCI, MEM, SEA, SFO, and TPA.

Diagrams of the 11 airports, showing the proposed short runways, are given in Figure 3-1. Shown on these diagrams are the locations of the airlines terminals (denoted by "T") and existing general aviation terminals on parking areas (denoted by

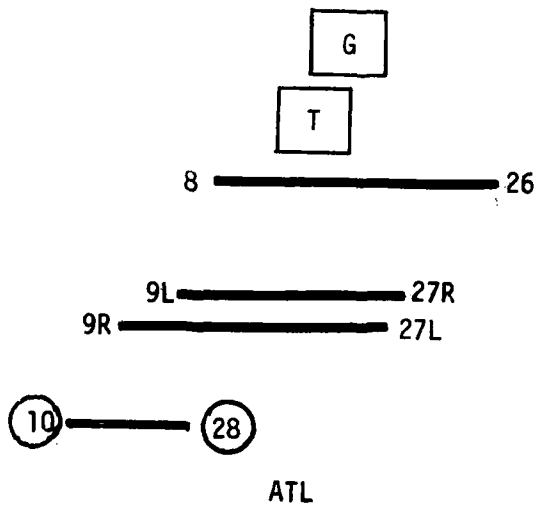
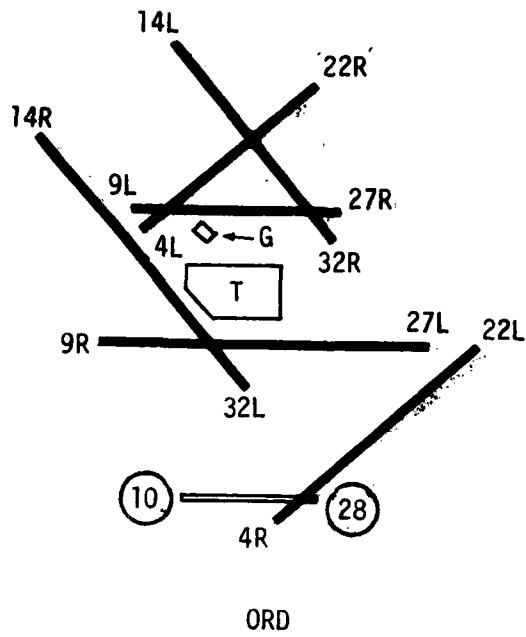

**FIGURE 3-1
AIRPORT LAYOUTS**

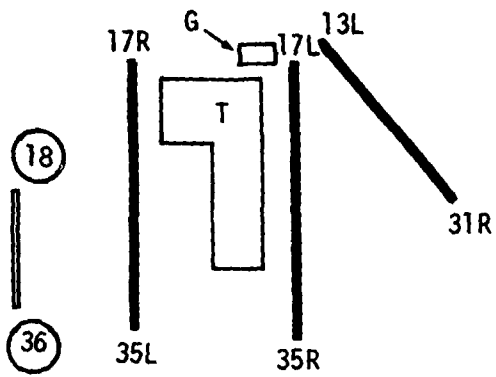

DFW

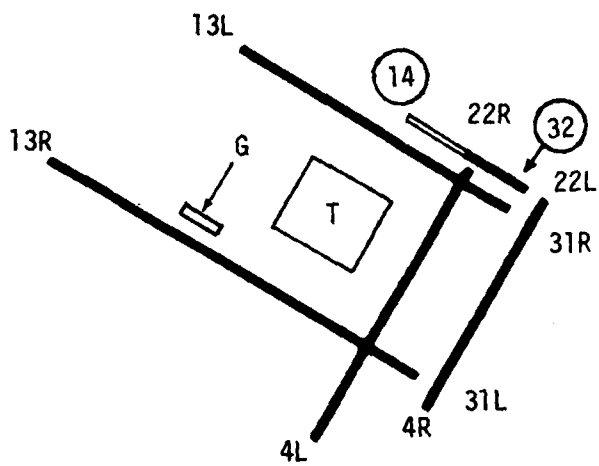

JFK

**FIGURE 3-1
AIRPORT LAYOUTS
(CONTINUED)**

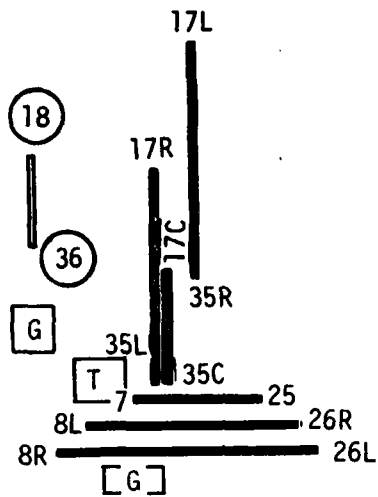

DEN

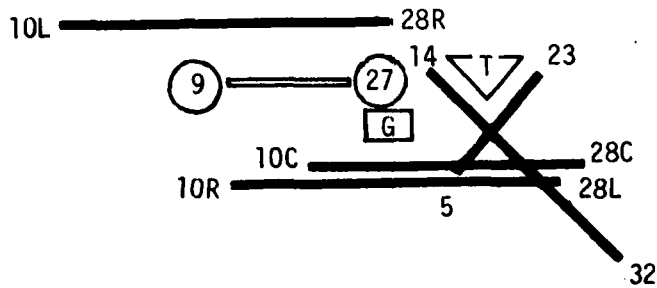

PIT

**FIGURE 3-1
AIRPORT LAYOUTS
(CONTINUED)**

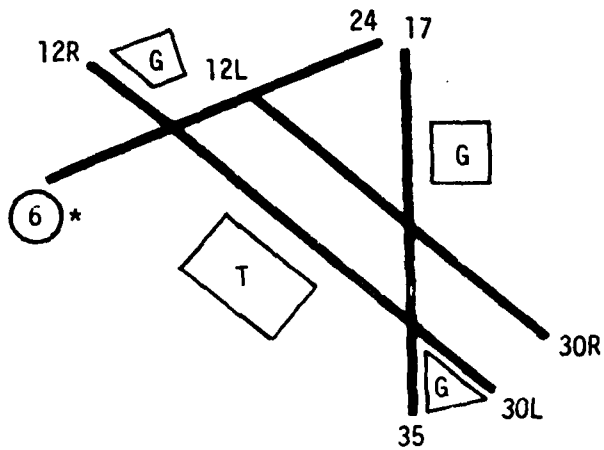

* SHORT RUNWAY OPERATION REQUIRES ARRIVALS ON
6 TO HOLD SHORT OF 12L

STL

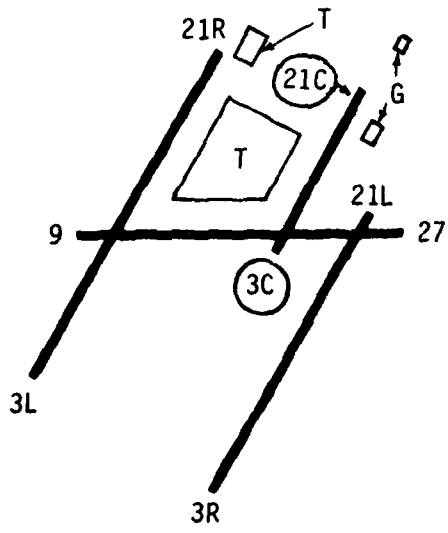

DTW

**FIGURE 3-1
AIRPORT LAYOUTS
(CONTINUED)**

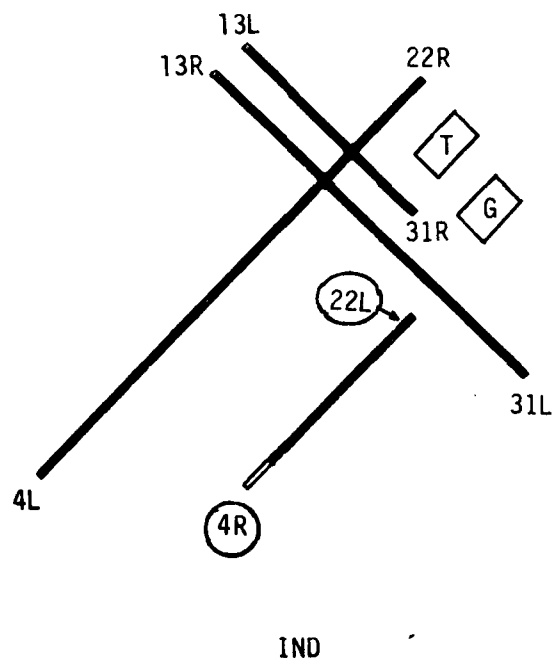
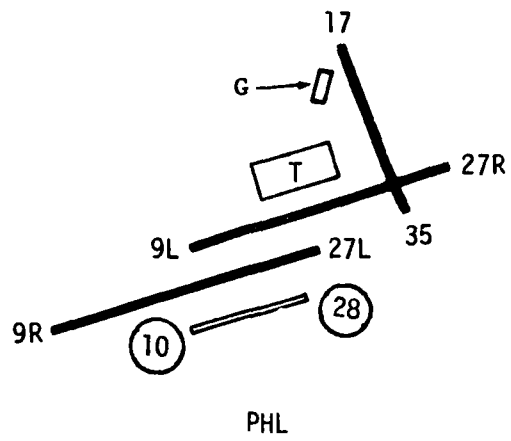

**FIGURE 3-1
AIRPORT LAYOUTS
(CONTINUED)**

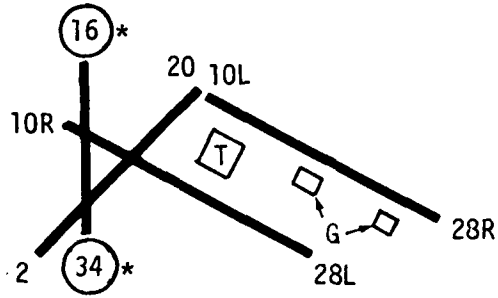

* PROPOSED RUNWAY 16/34 IS AN EXISTING TAXIWAY

PDX

NOTATION

- INDICATES PROPOSED SHORT RUNWAY
- INDICATES EXISTING PAVEMENT
- == INDICATES NEW CONSTRUCTION

**FIGURE 3-1
AIRPORT LAYOUTS
(CONCLUDED)**

"C"). In some cases (ORD, ATL, DFW, JFK, PHL, PDX) it was not possible to locate the short runway in close proximity to the general aviation terminal or parking area. For these airports it may be necessary to relocate the GA terminal to avoid taxiway/apron congestion and increased taxiing times which would offset the delay savings.

Runway configurations for the remaining 11 airports, both with and without the separate short runway, are given in Table 3-1. Capacity estimates (for 50% arrivals) for the airports, for forecasted 1980 and 1990 mixes, both with and without the separate runway, are given in Table 3-2.

3.3 Delay Estimates

Estimates of the average delay per operation were obtained for the 11 candidate airports, for 1980 and 1990 projected demand. This was done for all configurations which would use the proposed short runway and each configuration was run both with and without the short runway. These estimates are given in Table 3-3 for the full demand case and in Table 3-4 for the modified demand case.

Some of the estimates given in Table 3-3 are underestimates (denoted by * and **). This is because the delay model (Reference 7), which numerically integrates the Chapman-Kolmogorov system of differential equations describing the probability of there being n aircraft in the airport system ($n = 0, 1, 2, \dots$), uses as its initial condition an empty system. By choosing as the starting time ($t=0$) the hour before the start of the busy period, the maximum number of low-demand hours were placed at the end of the day. For almost all of the airports this resulted in steady state being reached at the end of 24 hours, that is the probability density function being very similar for $t = 0$ and $t = 24$ hours. For one run however, this steady state solution was not reached and the average delay estimate, calculated over one 24 hour period, is a lower bound. For two other runs the total daily demand was greater than the total daily capacity. In these cases there is no steady state solution; theoretical delays are unbounded. Finite delay estimates for these cases are due to using an empty system as the initial condition.

3.4 Savings Estimates

The delay estimates given in the previous section represent the average delay per operation for an average demand day of full IFR weather. By subtracting the average delay estimates for the

TABLE 3-1

CONFIGURATIONS WITH AND WITHOUT THE SEPARATE SHORT RUNWAY

AIRPORT	CONFIGURATION WITHOUT SHORT RUNWAY (ARR/DEP)	CONFIGURATION WITH SHORT RUNWAY (ARR/DEP)
ORD	27L, 27R/32L, 32R	27L, 27R, 28/28, 32L, 32R
ATL	26, 27L/26, 27R 8, 9R/8, 9L	26, 27L, 28/26, 27R, 28 8, 9R, 10/8, 9L, 10
DFW	35L, 35R/35L, 35R 17L, 17R/17L, 17R	35L, 35R, 36/35L, 35R, 36 17L, 17R, 18/17L, 17R, 18
JFK	31R/31L 13L/13R	31L, 32/31R 13R, 14/13L
DEN	35R/35L	35R, 36/35L, 36
PIT	10L, 10R/10L, 10C 28R, 28L/28R, 28C	10L, 10R/9, 10L, 10C 28R, 28L/27, 28R, 28C
STL	12R/12L	6, 12R/12L
DTW	3L, 3R/3L, 3R	3L, 3R/3L, 3R, 3C
PHL	27R/27L	27R, 28/27L
IND	4L/13R 4L/31L 22R/13R 22R/31L	4L, 4R/13R 4L, 4R/31L 22R, 22L/13R 22R, 22L/31L
PDX	10R/10L	10R, 16/10L

TABLE 3-2

AIRPORT CAPACITIES FOR THE CANDIDATE AIRPORTS

AIRPORT	CONFIGURATION (ARR/DEP)	CAPACITY (OPERATIONS/HOUR)*			
		1980		1990	
		WITHOUT SHORT RUNWAY	WITH SHORT RUNWAY	WITHOUT SHORT RUNWAY	WITH SHORT RUNWAY
ORD	27L, 27R/32L, 32R	115	149	112	138
ATL	26, 27L/26, 27R or 8, 9R/8, 9L	108	126	106	120
DFW	35L, 35R/35L, 35R or 17L, 17R/17L, 17R	104	139	102	149
JFK	31R/31L or 13L/13R	55	68	53	67
DEN	35R/35L	52	108	51	107
PIT	10L, 10R/10L, 10C 28R, 28L/28R, 28C	109 109	114 113	107 107	111 110
STL	12R/12L	56	61	55	59
DTW	3L, 3R/3L, 3R	101	105	99	103
PHL	27R/27L	55	61	55	61
IND	4L/13R or 22R/13R 4L/31L or 22R/31L	55 51	61 54	54 51	60 54
PDX	10R/10L	54	76	53	74

*Capacities correspond to 50% arrivals

TABLE 3-3
 AVERAGE DELAY PER OPERATION FOR THE
 CANDIDATE AIRPORTS - FULL DEMAND

AIRPORT	CONFIGURATION (ARR/DEP)	AVERAGE DELAY PER OPERATION (MINUTES)			
		1980		1990	
		WITHOUT SHORT RUNWAY	WITH SHORT RUNWAY	WITHOUT SHORT RUNWAY	WITH SHORT RUNWAY
ORD	27L,27R/32L,32R	40.68	1.37	50.06	3.64
ATL	26,27L/26,27R or 8,9R/8,9L	5.28	1.07	38.30	12.14
DFW	35L,35R/35L,35R or 17L,17R/17L,17R	0.65	0.13	6.51	0.30
JFK	31R/31L or 13L/13R	18.21	3.08	12.14	1.74
DEN	35R/35L	222.58*	1.74	321.56*	9.85
PIT	10L,10R/10L,10C 28R,28L/28R,28C	0.30 0.30	0.26 0.26	1.49 1.49	1.17 1.22
STL	12R/12L	25.76	10.95	54.57	32.01
DTW	3L,3R/3L,3R	0.18	0.16	0.34	0.29
PHL	27R/27L	57.85	20.79	157.71**	100.51
IND	4L/13R or 22R/13R 4L/31L or 22R/31L	1.82 2.43	1.13 1.89	5.19 7.06	3.11 5.48
PDX	10R/10L	1.93	0.38	9.10	1.07

* No Steady State Solution

** Steady State Not Reached By Delay Model

TABLE 3-4

AVERAGE DELAY PER OPERATION FOR THE
CANDIDATE AIRPORTS - MODIFIED DEMAND

AIRPORT	CONFIGURATION (ARR/DEP)	AVERAGE DELAY PER OPERATION (MINUTES)			
		1980		1990	
		WITHOUT SHORT RUNWAY	WITH SHORT RUNWAY	WITHOUT SHORT RUNWAY	WITH SHORT RUNWAY
ORD	27L,27R/32L,32R	27.69	0.85	31.76	1.43
ATL	26,27L/26,27R or 8,9R/8,9L	4.97	1.00	20.01	2.91
DFW	35L,35R/35L,35R or 17L,17R/17L,17R	0.65	0.13	6.01	0.29
JFK	31R/31L or 13L/13R	11.41	1.53	8.84	1.21
DEN	35R/35L	36.66	0.24	37.29	0.24
PIT	10L,10R/10L,10C 28R,28L/28R,28C	0.30 0.30	0.26 0.26	1.45 1.45	1.11 1.16
STL	12R/12L	20.24	7.12	36.11	17.41
DTW	3L,3R/3L,3R	0.18	0.16	0.34	0.29
PHL	27R/27L	35.85	9.32	35.80	10.45
IND	4L/13R or 22R/13R 4L/31L or 22R/31L	1.56 2.11	0.98 1.63	3.76 5.63	2.03 4.03
PDX	10R/10L	1.91	0.38	7.01	0.80

cases with the short runway from those for the cases without that runway, the average delay savings, in terms of time, were calculated. Multiplication by the proportion of IFR weather, the utilization of the particular configuration under IFR weather, and the total forecasted demand (reduced in those cases where demand modification called for rejection of demand) yielded the total delay savings, in aircraft-minutes. Multiplication by the average operating cost yielded the total delay savings, in 1980 dollars. The delay savings for each of the candidate airports, for 1980 and 1990, are given in Table 3-5. Using linear interpolation to estimate the delay savings of intermediate years and a discount rate of 10 percent per year, total discounted savings (in 1980 dollars) over the 11 year analysis time period were obtained for each candidate airport. These discounted savings estimates are given in Table 3-6.

Three airports (ORD, ATL and PHL) provide 70% to 77% of the total potential benefits due to reduced delay (ranges are obtained from the use of two sets of demand profiles). Total potential benefits were estimated to be about \$130M to \$195M for ORD, \$125M to \$180M for ATL, and \$90M to \$185M for PHL. Other airports may provide less potential benefits. IND, PDX, PIT and DTW account for only about 1% of the estimated potential delay reduction benefits.

Most of the estimated savings are incurred by the air carrier class, due to their higher operating expense. For example, at ORD the projected savings for air carriers were estimated to be \$120M to \$185M, compared to about \$10M for general aviation and air taxi operations.

TABLE 3-5
ANNUAL SAVINGS AT CANDIDATE AIRPORTS

AIR-PORT	GENERAL AVIATION AND AIR TAXI				DELAY SAVINGS 1980				AIR CARRIER			
	OP. COST (\$/MIN)	FULL DEMAND (\$ X 1000)	MODIFIED DEMAND (\$ X 1000)	OP. COST (\$/MIN)	MIN. (MIN. X1000)	OP. COST (\$/MIN)	MODIFIED DEMAND (\$ X 1000)	FULL DEMAND (\$ X 1000)	MIN. (MIN. X1000)	OP. COST (\$/MIN)	FULL DEMAND (\$ X 1000)	MODIFIED DEMAND (\$ X 1000)
ORD	7.40	198.1	135.3	23.83	1001.	23.83	1001.	959.2	22861.	654.9	15609.	
ATL	5.14	32.9	31.0	22.79	159.	22.79	159.	274.3	6252.	258.7	5896.	
DFW	7.44	3.8	3.8	21.56	29.	21.56	29.	12.4	268.	12.4	268.	
JFK	6.90	63.8	41.7	27.12	204.	27.12	204.	305.1	8273.	194.2	5402.	
DEN	5.29	471.8	57.9	21.28	306.	21.28	306.	558.0	11874.	68.5	1457.	
PIT	6.71	0.9	0.9	15.96	6.	15.96	6.	1.3	26.	1.3	26.	
STL	5.20	91.7	92.0	20.74	478.	20.74	478.	150.2	3115.	150.6	3123.	
DTW	4.80	0.1	0.1	23.63	1.	23.63	1.	3.2	5.	0.2	5.	
PHL	6.51	832.6	581.8	20.88	3786.	20.88	3786.	579.7	12080.	404.4	8442.	
IND	4.68	6.7	5.8	20.12	27.	20.12	27.	5.3	107.	4.6	92.	
PDX	4.48	7.0	6.9	22.78	31.	22.78	31.	5.0	137.	5.9	135.	
TOTAL					6028.		6028.		64998.		40455.	

AIR-PORT	GENERAL AVIATION AND AIR TAXI				DELAY SAVINGS 1990				AIR CARRIER			
	OP. COST (\$/MIN)	FULL DEMAND (\$ X 1000)	MODIFIED DEMAND (\$ X 1000)	OP. COST (\$/MIN)	MIN. (MIN. X1000)	OP. COST (\$/MIN)	MODIFIED DEMAND (\$ X 1000)	FULL DEMAND (\$ X 1000)	MIN. (MIN. X1000)	OP. COST (\$/MIN)	FULL DEMAND (\$ X 1000)	MODIFIED DEMAND (\$ X 1000)
ORD	7.40	234.0	145.7	26.70	1078.	26.70	1078.	1132.6	32246.	735.2	18831.	
ATL	6.04	244.4	159.8	24.64	965.	24.64	965.	2079.4	51239.	1359.2	33493.	
DFW	7.68	82.1	75.6	23.82	581.	23.82	581.	179.1	4265.	164.9	3928.	
JFK	4.68	41.2	30.3	30.42	141.	30.42	141.	189.5	5765.	139.0	4230.	
DEN	5.89	882.1	66.0	24.23	388.	24.23	388.	857.2	20769.	64.1	1553.	
PIT	7.02	11.2	12.0	22.78	84.	22.78	84.	11.1	252.	11.9	271.	
STL	6.53	93.5	77.5	23.61	506.	23.61	506.	304.3	7183.	252.1	5951.	
DTW	5.32	0.4	0.4	26.29	2.	26.29	2.	0.6	16.	0.6	16.	
PHL	8.08	1555.8	570.6	23.61	4611.	23.61	4611.	1383.3	25577.	397.3	9380.	
IND	5.07	26.6	24.2	21.55	123.	21.55	123.	13.2	414.	17.5	376.	
PDX	4.75	48.2	37.3	24.23	177.	24.23	177.	37.5	909.	29.0	703.	
TOTAL					8657.		8657.		146635.		78732.	

TABLE 3-6
DISCOUNTED SAVINGS AT CANDIDATE AIRPORTS
(\$ X 1000)

	GENERAL AVIATION PLUS		AIR TAXI		AIR CARRIER		TOTAL	
	FULL DEMAND	MODIFIED DEMAND	FULL DEMAND	MODIFIED DEMAND	FULL DEMAND	MODIFIED DEMAND	FULL DEMAND	MODIFIED DEMAND
ORD	11244.	7374.	184778.	120875.	196022.	128250.		
ATL	5004.	3479.	175292.	122255.	180297.	125733.		
DFW	1951.	1807.	13517.	12540.	15469.	14347.		
JFK	1885.	1276.	51825.	35192.	53710.	36468.		
DEN	25662.	2426.	110663.	10689.	136325.	13115.		
PIT	255.	272.	845.	898.	1100.	1169.		
STL	3796.	3497.	34066.	30524.	37862.	34021.		
DTW	8.	8.	68.	68.	76.	76.		
PHL	59483.	29445.	125498.	63038.	184981.	92483.		
IND	525.	472.	1655.	1484.	2180.	1955.		
PDX	799.	646.	3219.	2614.	4018.	3260.		
TOTAL	110613.	50701.	701426.	400176.	812039.	450877.		

4. CONCLUSIONS AND RECOMMENDATIONS

Delay savings, under IFR conditions, due to an increase in capacity through the use of a separate short runway appear to be attainable at 11 out of the top 30 air carrier airports. Of these 11 airports, three would use existing short runways which are presently not utilized under IFR conditions, two would require the extension of existing short runways to a length of 4000 feet, and six would require the construction of new short runways.

Average IFR delay savings, in minutes per operation, vary from airport to airport to a maximum of over 30 minutes, using conservative demand profiles.

Total discounted IFR delay savings (in 1980 dollars with a 10% discounting rate) over the 1980 to 1990 time frame, for all 11 candidate airports range from about \$450 million to about \$810 million depending on the traffic level. Of this, \$400M to \$700M will be saved by air carriers, and \$50M to \$110M will be saved by the commuter, air taxi and general aviation communities.

The analysis concerned itself with potential benefits only; construction and maintenance costs for new runways were not estimated. Although the total savings across the 11 airports are estimated to be quite large, these savings are by no means evenly distributed over all airports. Chicago, Atlanta and Philadelphia account for 70% to 77% of the total benefits. Almost 99% of the benefits are accounted for with the addition of Dallas-Ft. Worth, Kennedy, Denver, and St. Louis. In order to evaluate the worthiness of the proposed runway at each airport one would have to estimate, in addition to any construction and maintenance costs, the cost of the additional operational complexity required to segregate traffic and provide an additional approach stream. It is unlikely that all candidate runways would yield an attractive benefit/cost ratio. However, the analysis indicates that there are substantial benefits to be realized at particular airports and that a more detailed investigation of some of the more promising airports should be undertaken.

APPENDIX A

PARAMETERS USED IN THE ANALYSIS

A.1 Inputs to the Capacity Model

Presented in this section are the data that were used to calculate the capacities for the airport/configurations which may benefit from the use of a separate short runway for general aviation and air taxi operations. Capacities were calculated both with and without the separate runway, and for both the forecasted 1980 and 1990 aircraft mixes. These mixes are given in Table A-1. Much of the input corresponds to the application to specific airports of the general rules and regulations of today's Air Traffic Control System, such as interarrival longitudinal separation standards and departure-departure spacings, and is not presented. However, input pertaining to airport specific parameters, such as times to clear intersections or separations between parallel runways, are given in Table A-2. Input data that are not airport specific or which have been assumed to be constant over the candidate airports are given in Table A-3. For example, arrival runway occupancy times used were the default values stored in the model and represent occupancy times which are believed to be achievable given proper exit location and pilot motivation. Some parameters are a function of aircraft class; these classes were defined previously in Section 2.2.

A.2 Demand Profiles

Demand profiles were generated for each of the eleven candidate airports. Using the methodology described in section 2.3, daily demand profiles were generated for both 1980 and 1990 forecasted traffic, and for both full and modified demand scenarios. These profiles, four for each airport, are given in Figures A-1 through A-11.

A.3 Weather and Configuration Utilization Data

In the estimation of delay savings, the total forecasted traffic (reduced in those cases where there was rejection of demand) was reduced by the proportion of IFR weather and by the historic utilization of the particular configuration. The product of the resulting number of operations and the average delay savings per aircraft yielded the total delay savings, in aircraft-minutes, for the particular configuration. The data pertaining to IFR weather and configuration utilization are presented in Table A-4. Note that while IFR weather is defined to be ceiling below 1000 feet and/or visibility less than 3 nmi., due to the format of the data in Reference 8 it was assumed for this analysis that IFR weather was ceiling/visibility less than 1500 feet/3 nmi.

TABLE A-1
AIRCRAFT MIXES

<u>AIRPORT</u>	<u>1980</u>				<u>1990</u>			
	<u>S</u>	<u>L1</u>	<u>L2</u>	<u>H</u>	<u>S</u>	<u>L1</u>	<u>L2</u>	<u>H</u>
ORD	7	14	61	18	7	10	55	28
ATL	9	14	73	14	7	4	68	21
DFW	9	16	67	8	11	20	55	14
JFK	14	3	53	30	15	3	39	43
DEN	35	16	43	6	33	18	38	11
PIT	21	26	49	4	23	27	42	8
STL	29	11	55	5	13	11	62	14
DTW	30	9	48	13	28	9	43	20
PHL	33	31	32	4	17	42	33	8
IND	48	10	40	2	46	12	38	4
PDX	48	6	39	7	47	9	34	10

TABLE A-2

AIRPORT SPECIFIC PARAMETERS

ORD	Separation between 9R/27L and 9L/27R = 5000 feet Separation between 10/28 and 9R/27L >4300 feet Time for arrival on 27R to clear 32R = (8,8,5,5)* sec. Time for departure on 32R to clear 27R = (10,10,8,8)* sec.
ATL	Separation between 8/26 and 9L/27R = 4400 feet Separation between 9L/27R and 9R/27L = 1050 feet Separation between 9R/27L and 10/28 >4300 feet
DFW	Separation between 17R/35L and 17L/35R = 6300 feet Separation between 17R/35L and 18/36 >4300 feet
JFK	Separation between 13L/31R and 13R/31L = 6650 feet Separation between 13L/31R and 14/32 = 1300 feet Stagger: runway 14 is 1 nmi. beyond 13L
DEN	Separation between 17L/35R and 17R/35L = 1600 feet Stagger: runway 35R is 1 nmi. beyond 35L Separation between 17R/35L and 18/36 >4300 feet
PIT	Separation between 10L/28R and 10C/28C = 4400 feet Separation between 10C/28C and 10R/28L = 1200 feet Stagger: runway 10L is 0.5 nmi. beyond 10R Stagger: runway 28L is 0.2 nmi. beyond 28C Separation between 9/27 and 10C/28C = 2500 feet (independent departures) Separation between 9/27 and 10L/28R = 1900 feet Stagger: runway 9 is 6000 feet past 10L (implies that the 1900 foot separation is sufficient so that departures on 9 are independent of arrivals on 10L. However, departures on 27 are dependent on both arrivals and departures on 28R)
STL	Separation between 12L/30R and 12R/30L = 1300 feet Stagger: runway 12L is 0.5 nmi. beyond 12R Time for arrival on 6 to clear 12R = 33 sec. Time for arrival on 12R to clear 6 = 12 sec.
DTW	Separation between 3L/21R and 3C/21C = 3800 feet (implies departures on 3C are independent of arrivals and departures on 3L) Separation between 3C/21C and 3R/21L = 2100 feet Stagger: runway 3C is 1.0 nmi. beyond 3R (implies that the 2100 foot separation is sufficient so that departures on 3C are independent of arrivals on 3R)

*These groups of 4 numbers correspond to the 4 aircraft classes

TABLE A-2

AIRPORT SPECIFIC PARAMETERS
(Concluded)

PHL Separation between 9L/27R and 9R/27L = 1400 feet
Stagger: runway 27L is 0.8 nmi. beyond 27R
Separation between 9R/27L and 10/28 = 1600 feet
Stagger: runway 28 is 0.3 nmi. beyond 27L

IND Separation between 4L/22R and 4R/22L = 3700 feet (implies 2.0 nmi.
diagonal interarrival spacing between the two runways)
Time for arrival on 4L to clear 13R/31L = (39,39,39,45)* sec.
Time for arrival on 22R to clear 13R/31L = (15,15,10,10)* sec.
Time for departure on 13R to clear 4L/22R = (20,20,15,15)* sec.
Time for departure on 31L to clear 4L/22R = (30,30,20,20)* sec.

PDX Separation between 10L/28R and 10R/28L = 3100 feet (implies that
departures on 10L are independent of arrivals on 10R)
Time for arrivals on 10R to clear 16 = 10 sec.
Time for arrivals on 16 to clear 10R = 27 sec.

*These groups of 4 numbers correspond to the 4 aircraft classes

TABLE A-3

AIRPORT INDEPENDENT PARAMETERS

Distance to outer marker	5 nmi			
Interarrival Delivery Error (Standard Deviation)/Number of Standard Deviations Protected	18 sec./1.65			
	<u>AIRCRAFT CLASS</u>			
	<u>S</u>	<u>L₁</u>	<u>L₂</u>	<u>H</u>
Approach Velocities (outside O.M.) (Kts.)	160	160	160	160
Final Velocities (Inside O.M.) (Kts.)	120	130	130	140
Arrival Runway Occupancy Protection Time (includes buffer) (sec.)	34	41	49	52
Departure Runway Occupancy Protection Time (includes buffer) (sec.)	20	34	39	39

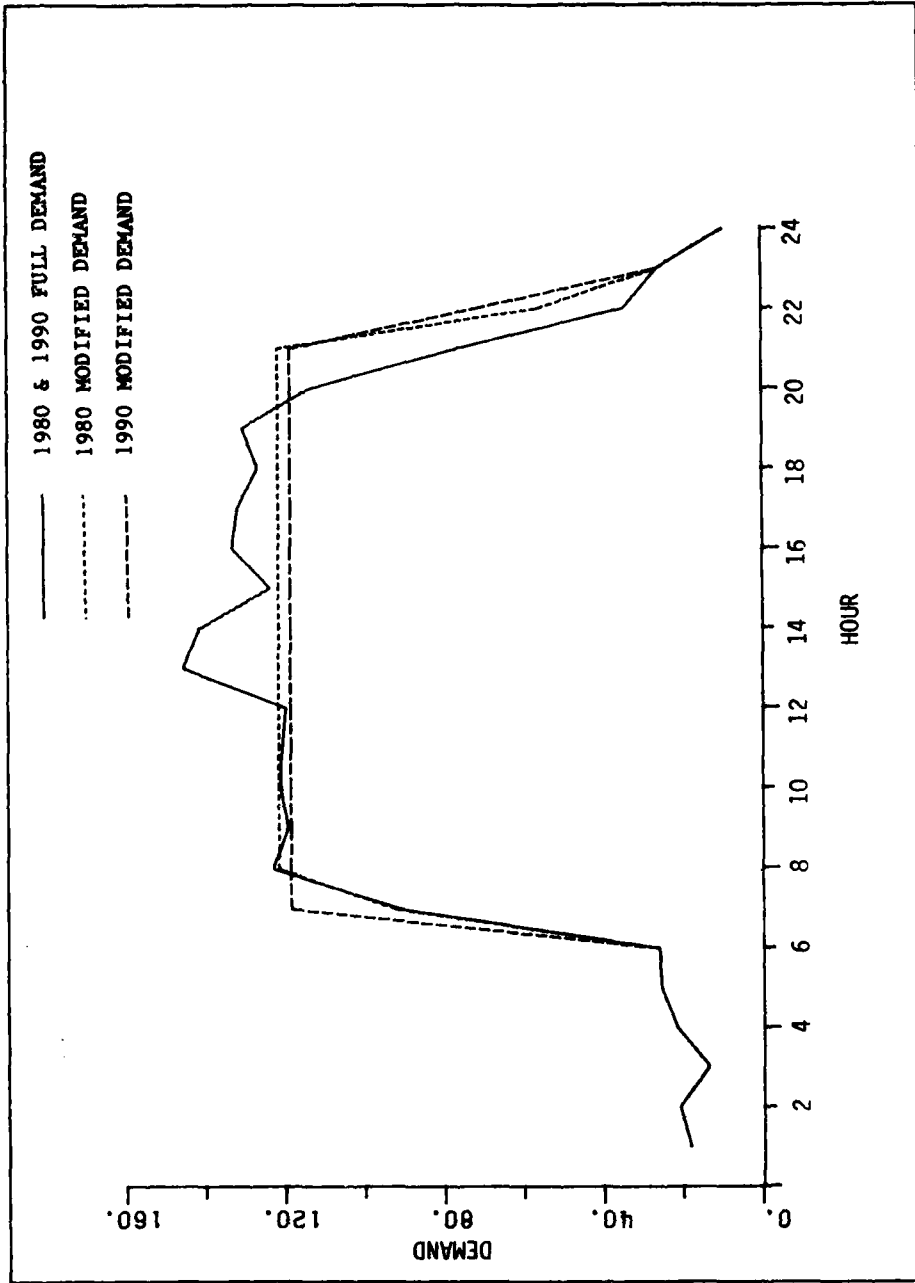

FIGURE A-1
DEMAND PROFILES FOR ORD

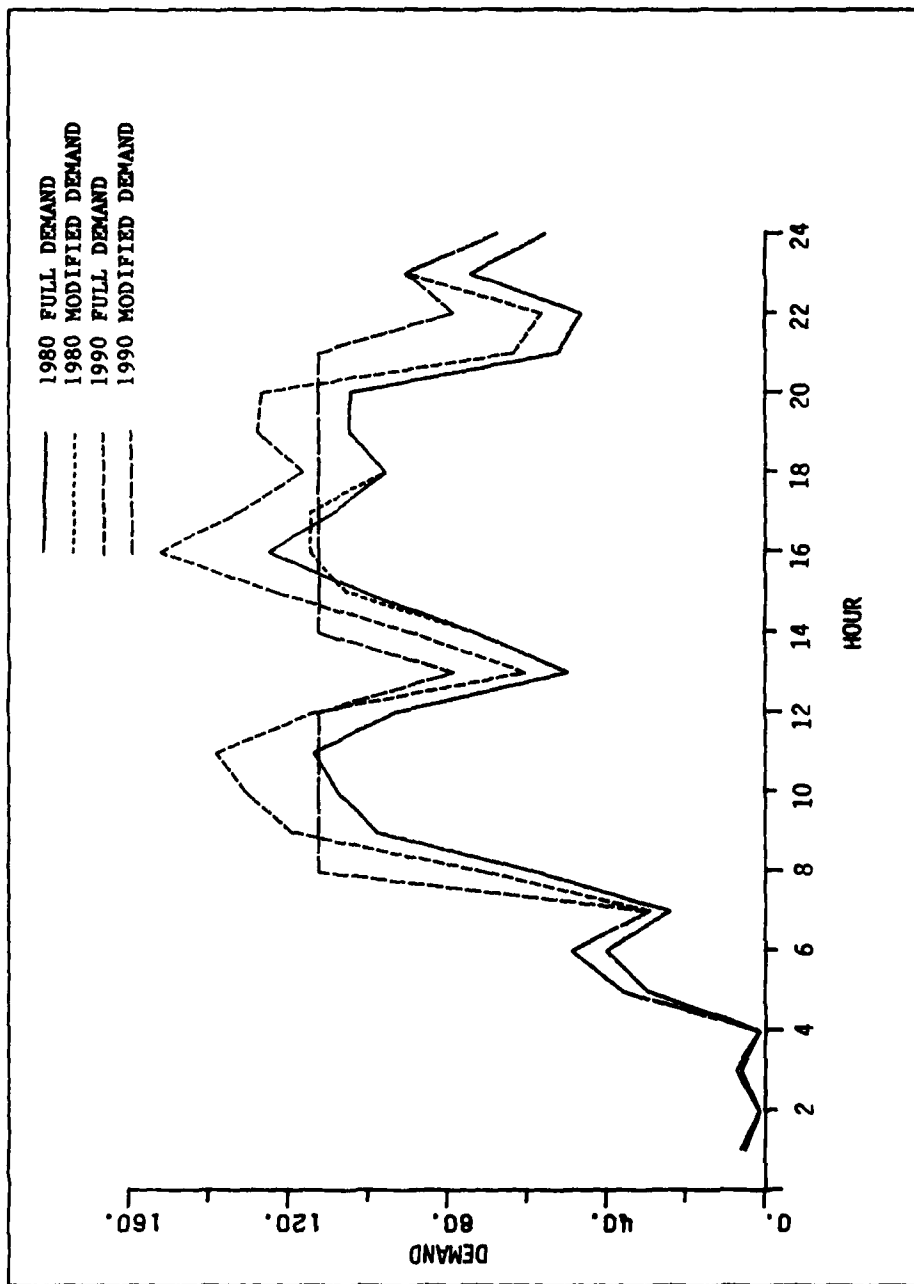

FIGURE A-2
DEMAND PROFILES FOR ATL

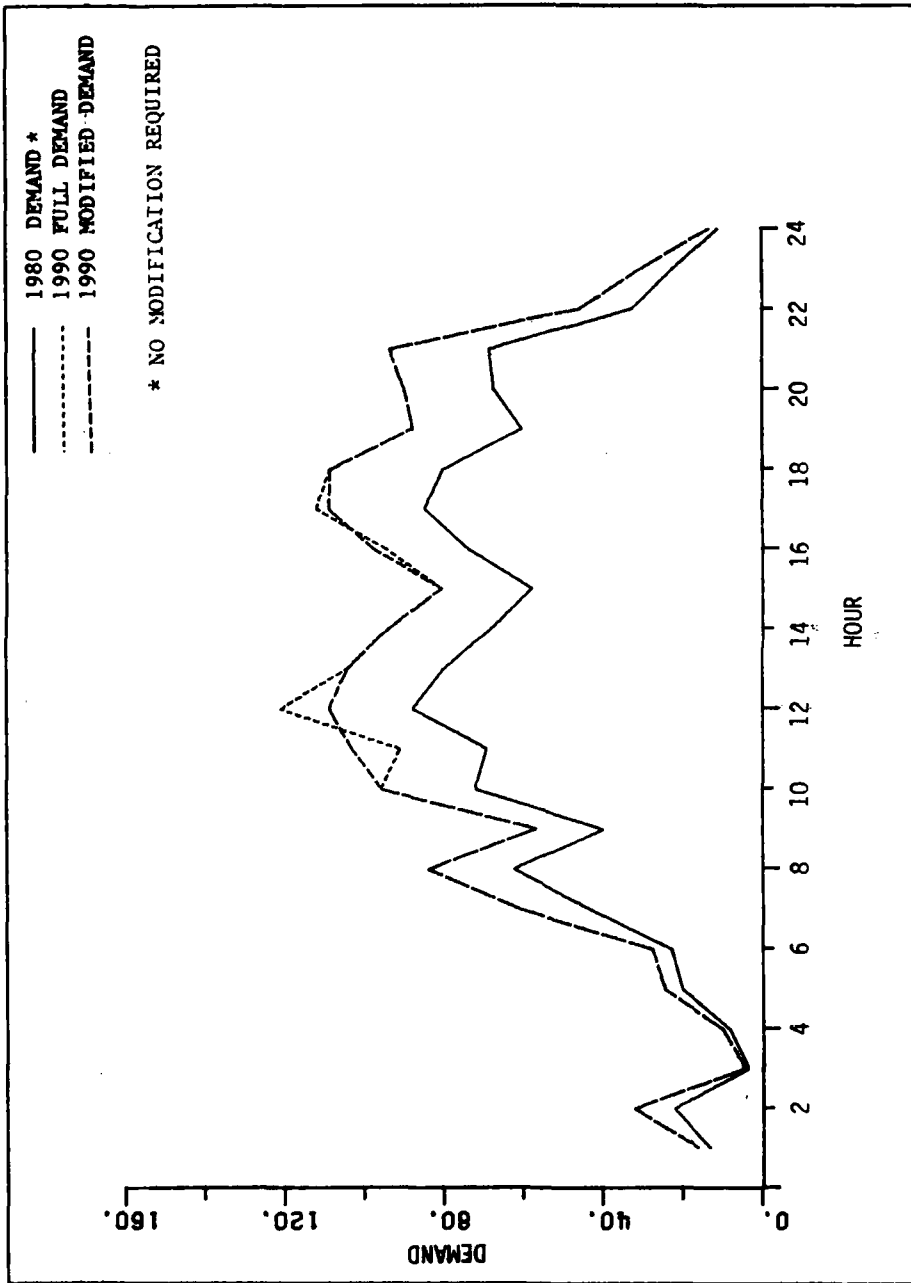

FIGURE A-3
DEMAND PROFILES FOR DFW

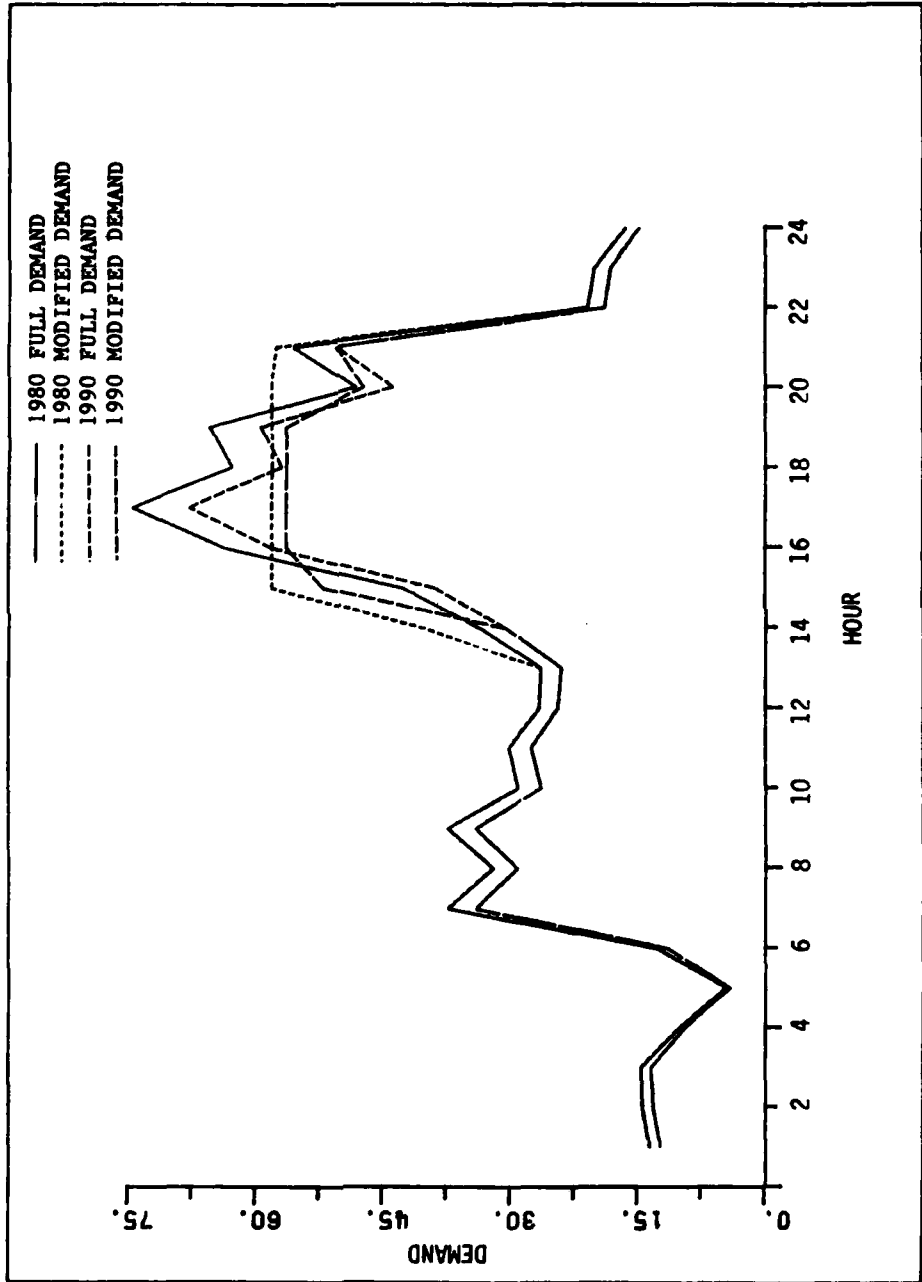

FIGURE A-4
DEMAND PROFILES FOR JFK

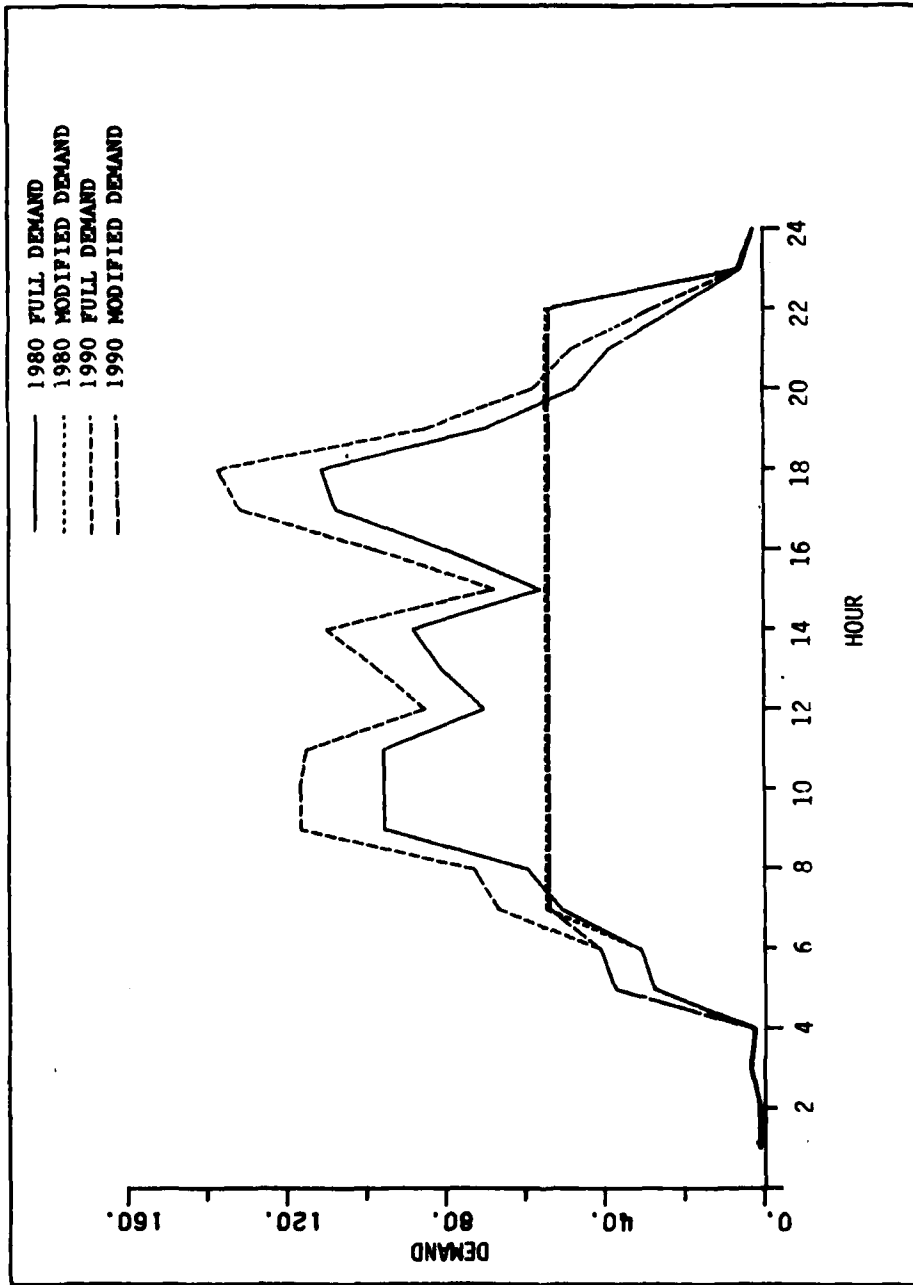

FIGURE A-5
DEMAND PROFILES FOR DEN

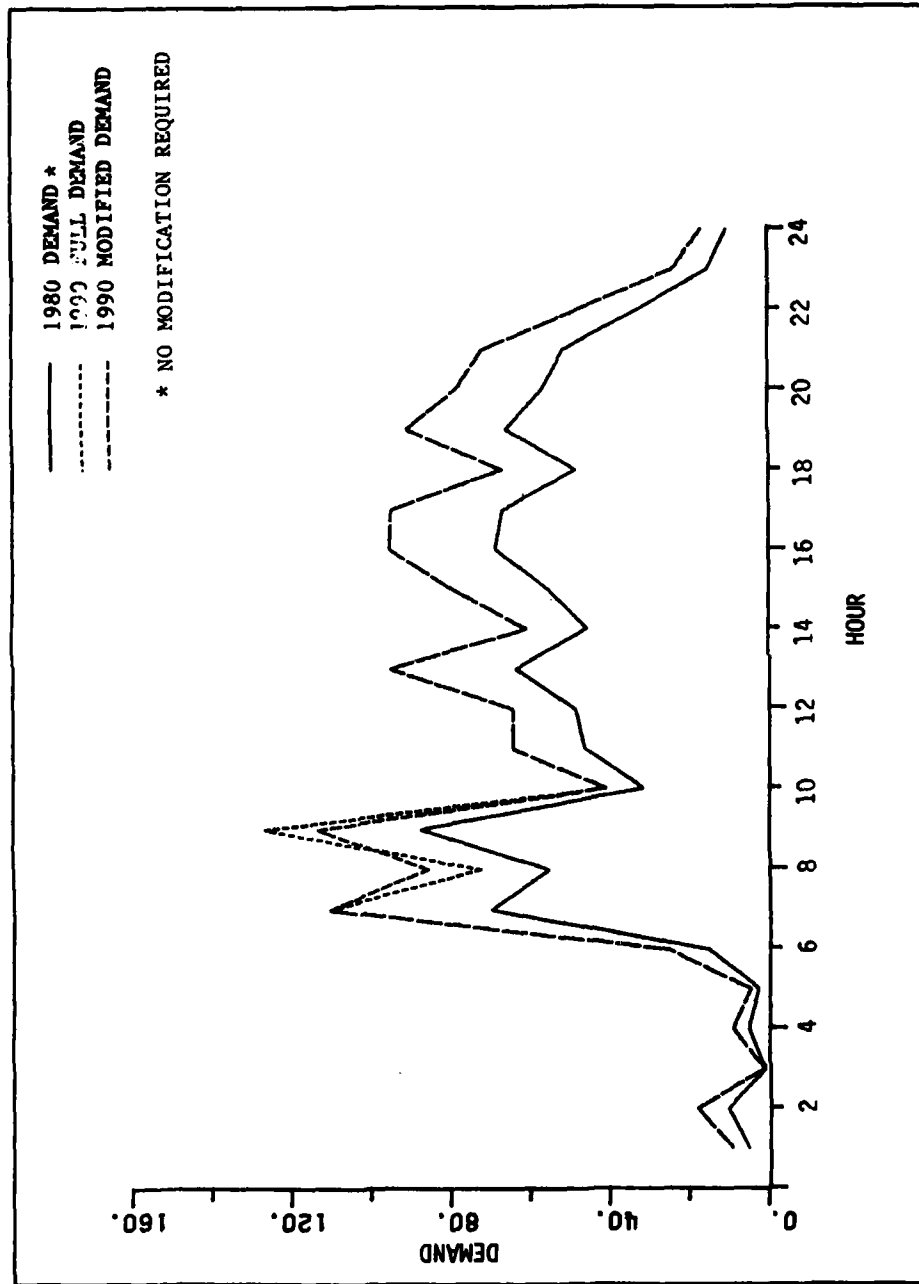

FIGURE A-8
DEMAND PROFILES FOR PIT

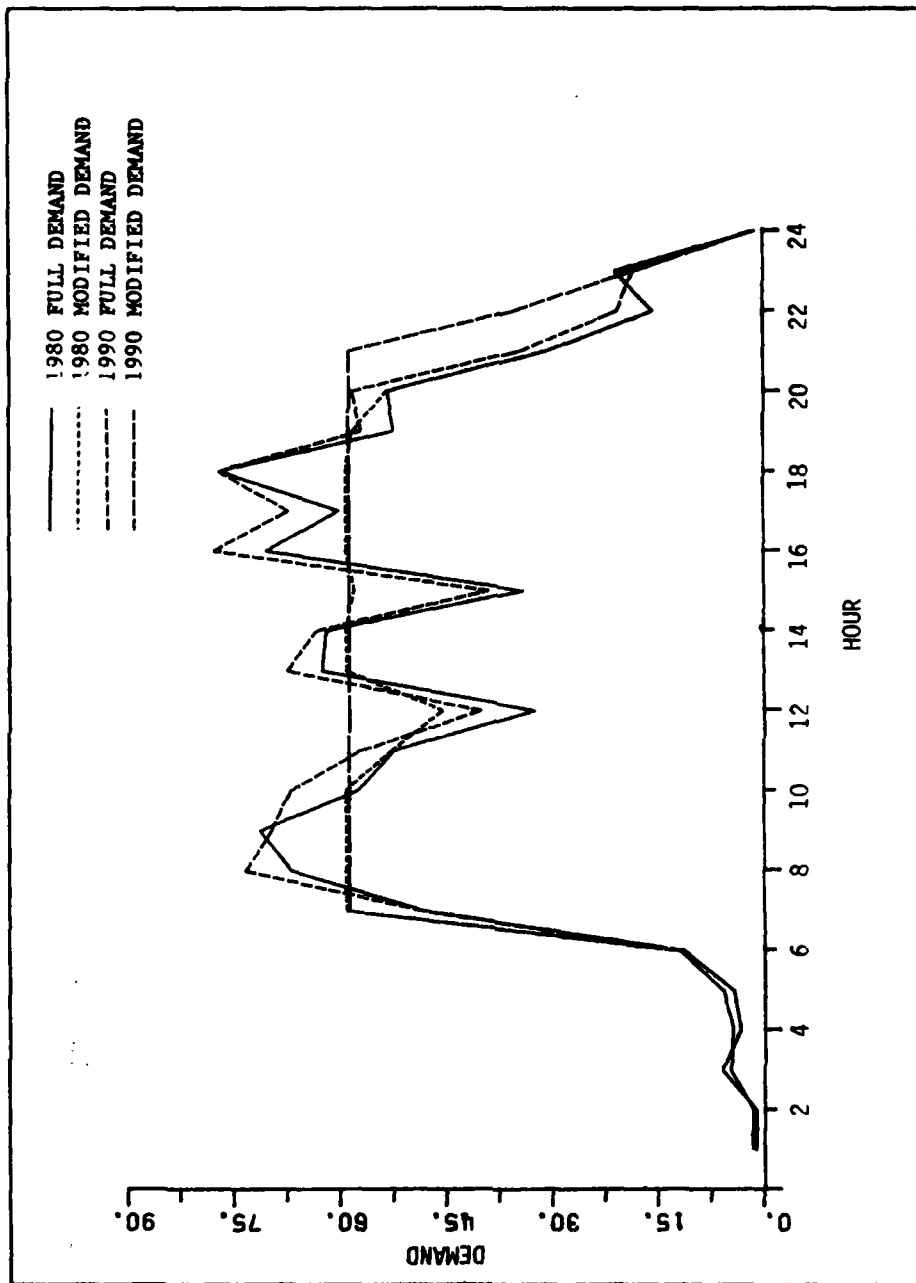

FIGURE A-7
DEMAND PROFILES FOR STL

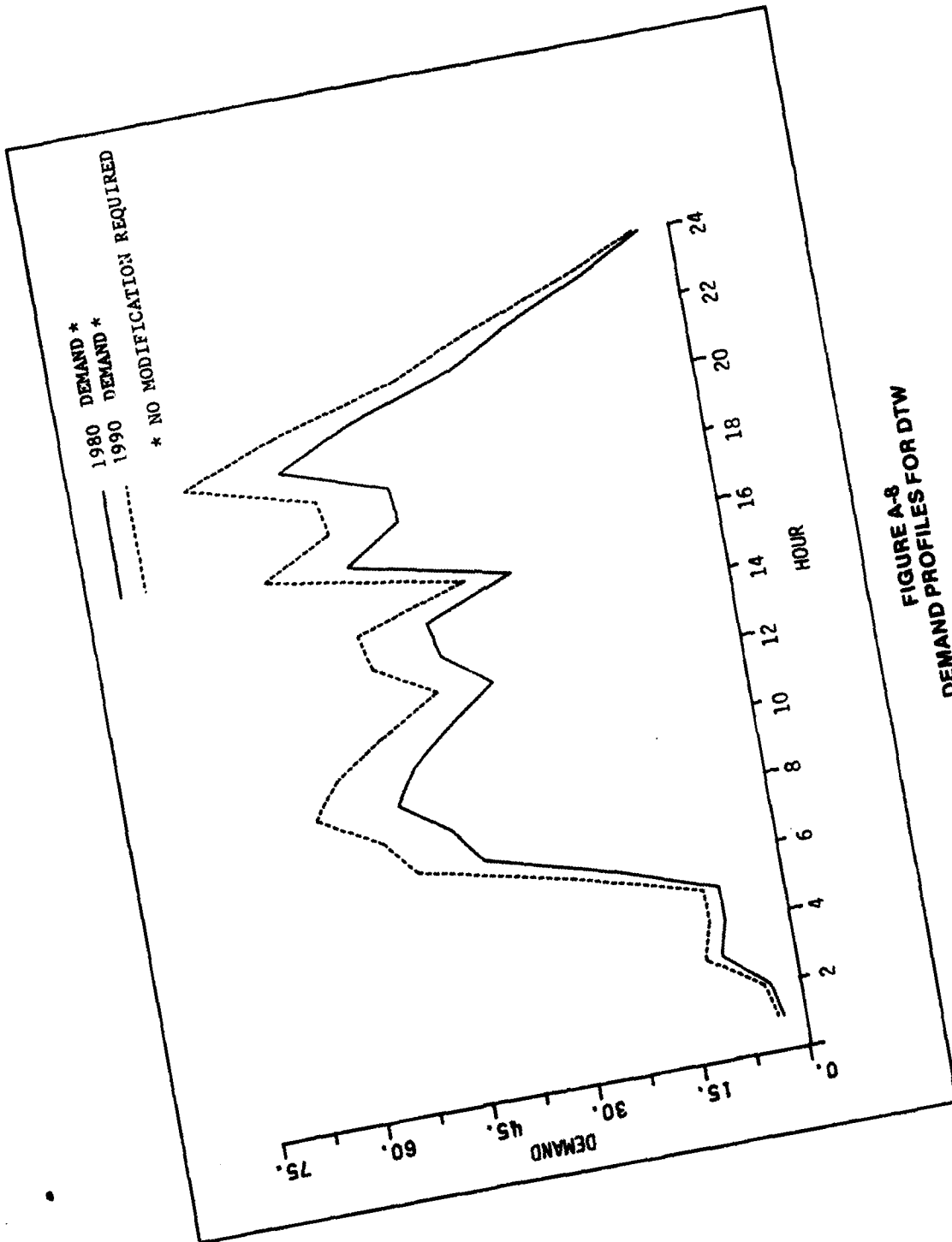

FIGURE A-8
 DEMAND PROFILES FOR DTW

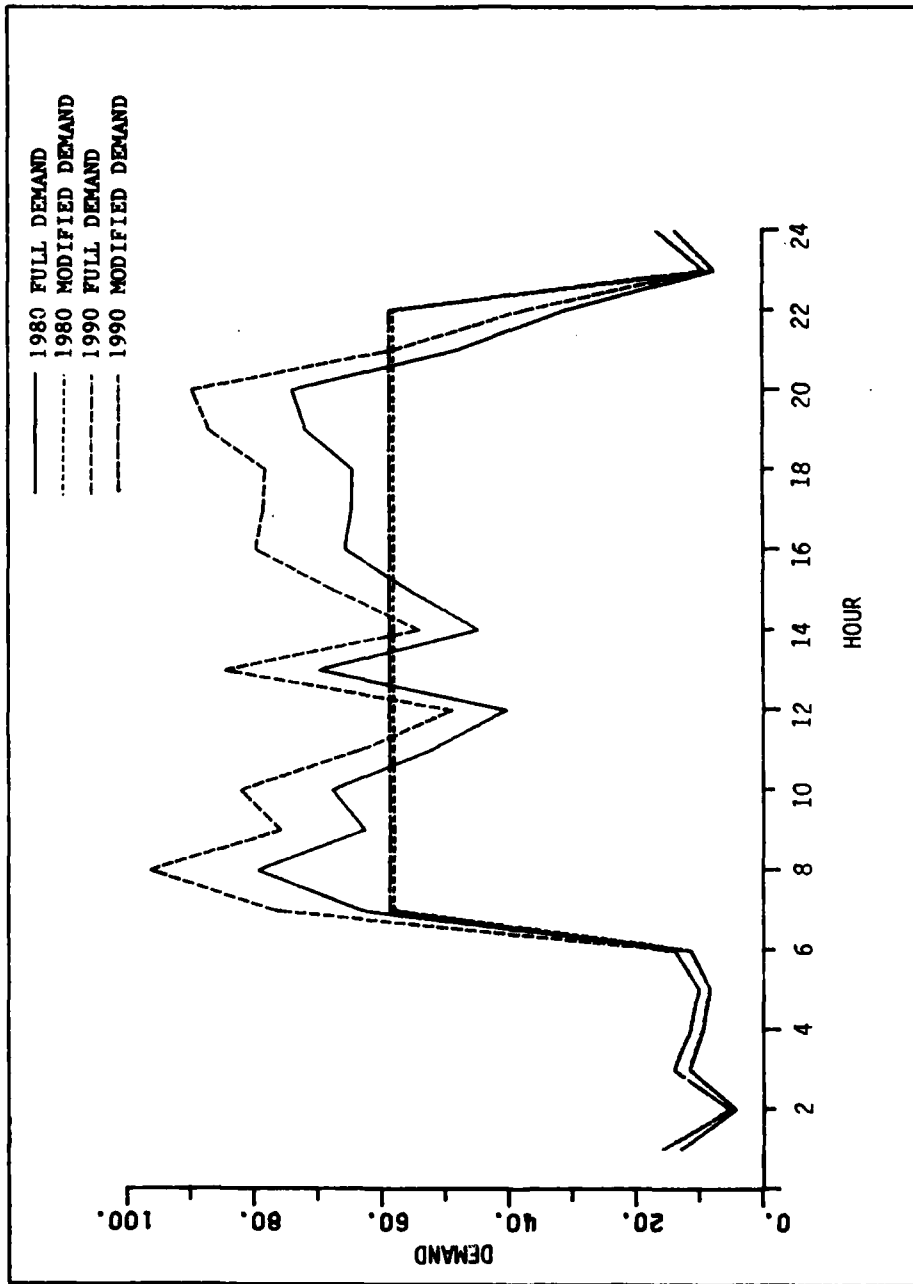

FIGURE A-9
DEMAND PROFILES FOR PHL

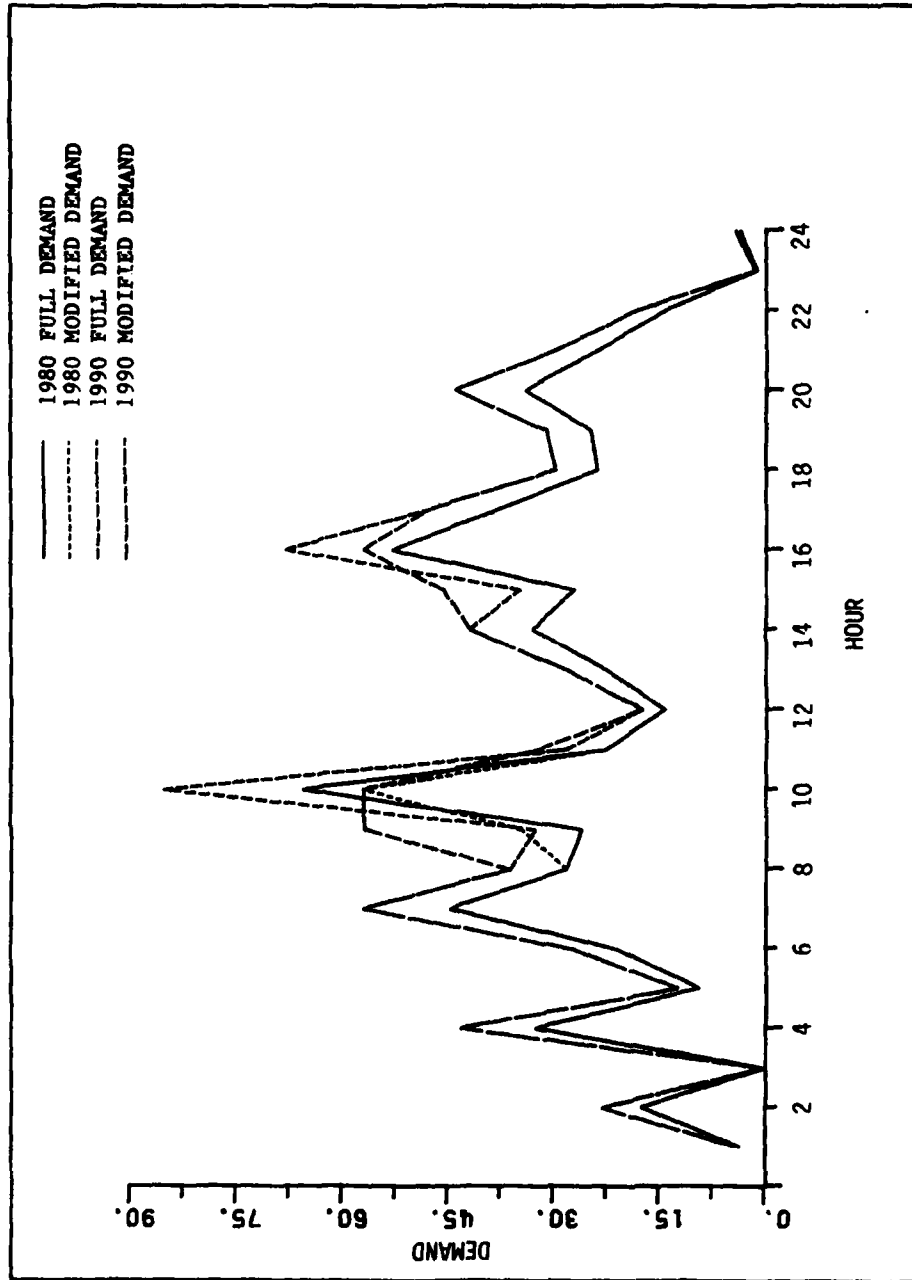

FIGURE A-10
DEMAND PROFILES FOR IND

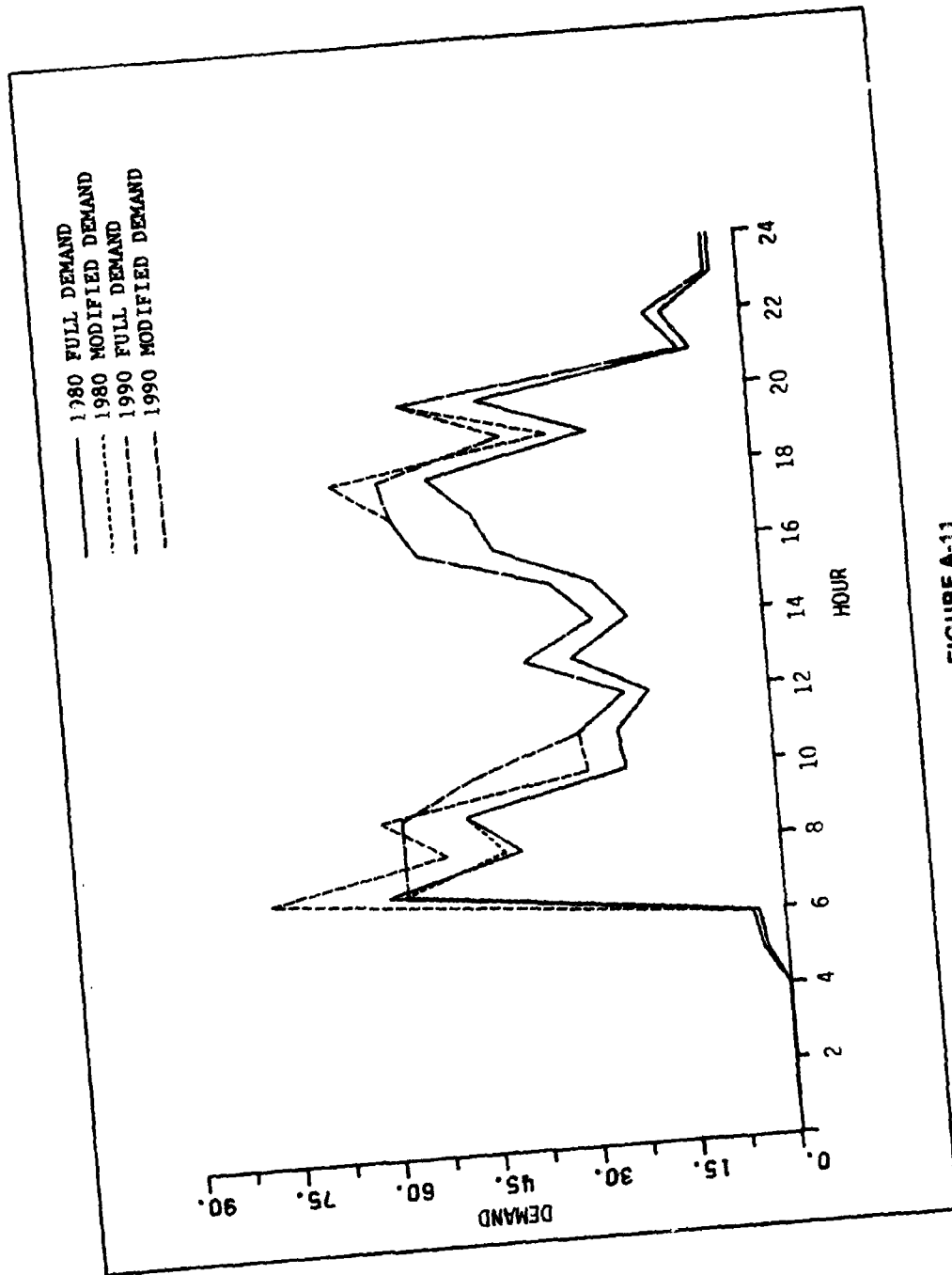

FIGURE A-11
DEMAND PROFILES FOR PDX

TABLE A-4
 WEATHER AND CONFIGURATION USE DATA

<u>AIRPORT</u>	<u>CONFIGURATION (ARR/DEP)</u>	<u>COMBINED UTILIZATION AND WEATHER FACTOR</u>
ORD	27L,27R/32L,32R	.040
ATL	26,27L/26,27R or 8,9R/8,9L	.128
DFW	35L,35R/35L,35R or 17L,17R/17L,17R	.073
JFK	31R/31L or 13L/13R	.084
DEN	35R/35L	.010
PIT	10L,10R/10L,10C 28R,28L/28R,28C	.024 .137
STL	12R/12L	.050
DTW	3L,3R/3L,3R	.058
PHL	27R/27L	.101
IND	4L/13R or 22R/13R 4L/31L or 22R/31L	.046 .046
PDX	10R/10L	.045

APPENDIX B

REFERENCES

1. "FAA Air Traffic Activity - Calendar Year 1976," Federal Aviation Administration, December 1976.
2. Garner, J. D., "Operational Feasibility of a Separate Short Runway for Commuter and General Aviation Traffic at Denver," The MITRE Corporation, Metrek Division, to be published.
3. Amodeo, F. A., Haines, A. L., and Sinha, A. N., "Concepts for Estimating Capacity of Basic Runway Configurations," The MITRE Corporation, Metrek Division, MTR-7115, Rev. 1, March 1977.
4. "Terminal Area Forecasts," Federal Aviation Administration, FAA-AVP-78-6, June 1978.
5. "UG3RD Baseline and Implementation Scenario," Federal Aviation Administration, FAA-AVP-77-19, January 1977.
6. "Profiles of Scheduled Air Carrier Departure and Arrival Operations," U. S. Department of Transportation, August 1976.
7. Hengsbach, G. and Odoni, A. R., "Time Dependent Estimates of Delays and Delay Costs at Major Airports," Flight Transportation Laboratory, Massachusetts Institute of Technology, R75-4, January 1975.
8. "Ceiling-Visibility Climatological Study and Systems Enhancement Factors," U. S. Department of Commerce, National Oceanic and Atmospheric Administration, National Climatic Center, DOT-FA75WAI-547, June 1975.
9. "Aircraft Operating Cost and Performance Report," Civil Aeronautics Board, July 1977.
10. Information from Steven G. Smith, Finance and Cost Section, Economic Evaluation Division, Civil Aeronautics Board, April 1978.
11. "The Annual Report of the Council of Economic Advisers," January 1978.
12. Office of Management and Budget, "Discount rates to be used in evaluating time-distributed costs and benefits," Circular No A-94 Revised, March 1972.