

AD-A081 733

DAVID W TAYLOR NAVAL SHIP RESEARCH AND DEVELOPMENT CE--ETC F/0 19/1
PRELIMINARY STABILITY STUDIES OF SHAPES SUITABLE FOR HIGH DENSIT--ETC(U)
NOV 68 B C STRACHAN

UNCLASSIFIED

NL

[]
[]

END
DATE
FILMED
4-80
DTIC

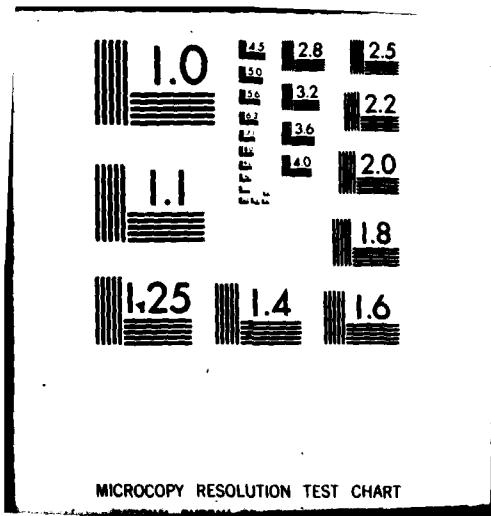

LEVEL 2

NAVY DEPARTMENT
NAVAL SHIP RESEARCH AND DEVELOPMENT CENTER
AERODYNAMICS LABORATORY

WASHINGTON, D. C. 20007

PRELIMINARY STABILITY STUDIES OF SHAPES SUITABLE
FOR HIGH DENSITY, CLUSTERED PACKAGING

by

10 Brian C. Strachan

11 1101 61

12 28

DTIC ELECTE
S MAR 1 2 1980 D

A

~~This document is subject to special export controls and such dissemination to foreign governments or foreign nationals may be made only with the approval of the Head, Aerodynamics Laboratory.~~

APPROVED FOR PUBLIC RELEASE:
distribution unlimited

6 Mar 1980

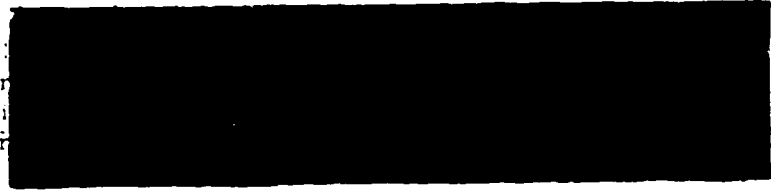

NAVAL ...

12 Dec 66

November 1966

14 JINNAH
9 Technical Note AL-80

80 3 12 017

387675

Handwritten initials

ADA 081 733

DDC FILE COPY

PRELIMINARY STABILITY STUDIES OF SHAPES SUITABLE
FOR HIGH DENSITY, CLUSTERED PACKAGING

TABLE OF CONTENTS

	Page
SUMMARY	1
INTRODUCTION	1
SYMBOLS	1
MODELS	2
APPARATUS AND TEST PROCEDURE	3
RESULTS AND DISCUSSION	3-5
CONCLUSIONS	6
REFERENCE	6

LIST OF TABLES

Table 1 - Stability Characteristics of Blunt Subweapons	7-12
Table 2 - Stability Characteristics of Cluster Weapons (with nose and tail fairings)	13-19

LIST OF FIGURES

Figure 1 - Longitudinal Geometric Characteristics	20
Figure 2 - Cross-Sectional Characteristics of Blunt Subweapons	21-22
Figure 3 - Cross-Sectional Characteristics of Cluster Weapons	23-24

SUMMARY

Preliminary stability studies were conducted on shapes suitable for high density, clustered packaging. One-degree-of-freedom, free oscillation tests were conducted in the 7- by 10-Inch Transonic Wind Tunnel at Mach numbers of 0.50 and 0.80. Blunt subweapons, with rectangular fins as stabilizing devices, were tested as well as clusters with nose fairings, tail fairings, and "clipped-delta" fins. The results of this study are qualitatively presented in tabular form. The only shape which was both statically and dynamically stable for all modes was a cylindrical blunt body.

INTRODUCTION

The concept of utilizing high density, packaged cluster weapons which would separate into subweapons following launch has become attractive for many military applications. A feasibility study of these weapons has been initiated in the Aerodynamics Laboratory. One phase of this study was to investigate the static and dynamic stability characteristics of numerous shapes which lend themselves to the cluster concept (i.e., either a cluster itself or a subweapon). A one-degree-of-freedom, free oscillation wind tunnel test was conducted to obtain qualitative stability characteristics.

SYMBOLS

D	reference length, feet
I_{yy}	pitch moment of inertia, slug-ft ²
q	dynamic pressure, pounds/feet ²
S	reference area, feet ²
V	free-stream velocity, feet/second
α	angle of attack, degrees
τ	period of oscillation, seconds
ω	oscillation frequency, radians/second

MODELS

Two basic sets of models were tested - blunt bodies which represented individual subweapons, and bodies with nose and tail fairings which represented the cluster weapons. There were marked differences between the two sets, which will be discussed below; however, all models tested had two common characteristics. That is, they were all constructed of hardwood with a steel core inserted to insure a desirable moment of inertia. Secondly, square holes were drilled in each model at 50 percent of the body length (a possible full scale center of gravity) for the insertion of a transverse rod. In addition to supporting the models, this rod served as the axis of oscillation. The longitudinal geometric characteristics of each set are presented in Figure 1.

SUBWEAPONS

The blunt bodies were all 2.5" long and approximately 0.75" in diameter. The steel core, which was 2.25" long, was inserted from the rear and was flush with the aft end. Twenty-two different configurations were tested. This represented seven distinct cross-sections (the details of which are presented in Figure 2) tested in different roll orientations with various fin schemes. All fins, bonded into the wood, had identical, rectangular planforms (see Figure 1) and an exposed span of 0.5". The fin schemes and axis of oscillation for each configuration are shown in Table 1.

CLUSTERS

The clusters were all 4" long and were approximately 0.75" in diameter. Part of this length included detachable 0.75" length tangent-ogive nose and tail fairings. The steel core, which was 3" long, was inserted in the body (center section). It protruded from the forward and aft ends enough to allow attachment of the fairings. Twenty-six different configurations were tested. This represented seven distinct cross-sections (the details of which are presented in Figure 3) tested in different roll orientations with various fin schemes. All fins, bonded into the tail fairing, had identical "clipped-delta" planforms (see Figure 1) and an exposed span of 0.25". The fin schemes and axis of oscillation for each configuration are shown in Table 2.

APPARATUS AND PROCEDURE

The tests were conducted in the 7- by 10-Inch Transonic Wind Tunnel on the one-degree-of-freedom, free oscillation rig. This consisted primarily of a thin vertical rod which went through the slots in the test section floor and ceiling. The bottom portion of this rod, which rested below the test section, came to a sharp hardened point which allowed it to rotate with a minimum of friction. The upper portion had a pointer welded to the shank. A 360° angle indicator was fixed on the top of the tunnel and under the pointer.

The model was mounted to and supported by the rod in the center of the test section. As the model rotated, so did the rod and indicator. Once the tunnel attained the desired speed, the model was rotated to the desired angle-of-attack and then released. The subsequent motion of the model was recorded by filming the motion of the indicator over the compass. A timing light was simultaneously recorded on the film so that a time history of the angle-of-attack could be studied. For this test a Photosonic camera was used at a film speed of approximately 350 frames/sec.

All 48 configurations were tested at a Mach number of 0.5 and most of these were also tested at a Mach number of 0.8. If a configuration was quite unstable at the lower Mach number, it was eliminated from further consideration. The tunnel was run consistently at a total pressure of approximately 1000 psf. The dynamic pressure was approximately 148 psf at $M = 0.5$ and approximately 294 psf at $M = 0.8$.

RESULTS AND DISCUSSION

The theory covering the analysis of free oscillation tests is given in Reference 1. If the time history of one-degree-of-freedom free oscillation is plotted, it will look like the following sketch:

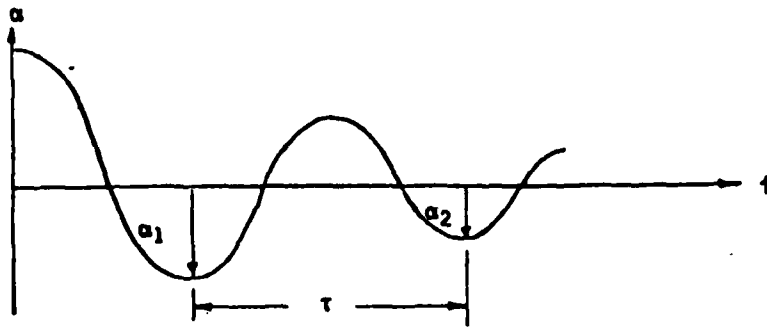

The pitch damping derivative is determined in the following equation:

$$C_{m_q} + C_{m_{\dot{\alpha}}} = - \left(\frac{2}{\tau} \right) \left(\frac{2V}{D} \right) \left(\frac{I_{yy}}{qSD} \right) \log_e \left(\frac{\alpha_1}{\alpha_2} \right)$$

The static pitching moment slope is given by:

$$C_{m_{\alpha}} = - \frac{\omega^2 I_{yy}}{qSD (57.3)}$$

where

$$\omega = \frac{2\pi}{\tau}$$

From these equations it can be seen that the necessary and sufficient requirements for a model to be dynamically stable are that τ be finite and that α_1 be greater than α_2 . For static stability the only requirement is that τ be finite. Therefore, one can obtain qualitative stability characteristics rapidly by observing the motion picture of the data. If a model oscillates, then it is statically stable and if the oscillatory motion is continually damped, then it is also dynamically stable. One can obtain quantitative stability characteristics by reading the film and using the above equations.

Since this examination was preliminary in nature and the goal was to determine which shapes were promising, it was decided that the former approach (i.e., qualitative) would be sufficient. All films were reviewed and the dynamic and static stability was recorded as either affirmative or negative. The results are presented in Table 1 for the blunt subweapons and in Table 2 for the clusters with the fairings.

It can be noted that many of the configurations tested were statically stable. On the other hand, the dynamic stability characteristics of the majority of configurations were poor. Only one set of configurations - circular, blunt subweapons - was completely stable with both "x" and "plus" fin configurations. A few other configurations were marginally stable. For example, the clipped-triangle cross-section, blunt body was essentially stable at angles of attack less than 20° . Some other configurations were completely dynamically unstable. The square cross-section with slightly rounded corners (configurations 3-6) is an example of this case. Rather than discussing each configuration, the reader is directed to Tables 1 and 2 for the results.

An investigation of the data leads to a few important observations. The concept of constructing models with a basic steel core and interchangeable bodies is attractive from a standpoint of economy and model construction. It is particularly ideal for tests where minor body modifications are desired throughout the test. However, this concept demands that a model have a diameter larger than possible with a solid body (i.e., a solid body could have a diameter identically equal to that of the core itself). Thus to obtain a desired fineness ratio, the body has to be longer. As previously stated, some of the models for this test were approximately 4" long and 0.75" in diameter. It is suspected that these bodies used in this test were too large for the tunnel. This suspicion is verified by the recurrence of noticeable wall effects throughout the test. Many models oscillated around 60° , broke out of this cycle and then oscillated about zero degrees.

A final observation is that the fins for the cluster weapons could probably have had more span. It is suspected that, with flow separation, much of the fin was ineffective.

CONCLUSIONS

Of all the models tested, the blunt bodies with circular cross-sections exhibited the best stability characteristics. However, it should be remembered that this was an initial look at stability characteristics. Future investigations should incorporate smaller models with relatively larger fin spans, and possibly greater fineness ratios.

Aerodynamics Laboratory
Naval Ship Research and Development Center
Washington, D. C. 20007
September 1968

REFERENCE

1. O'Neill, Edwin B. and Kenneth A. Phillips. A Description of Four Wind-Tunnel Dynamic Measuring Techniques. Wash., Mar 1967. 49 p. incl. illus. (Naval Ship Research & Development Ctr. Rpt. 2296. Aero Rpt. 1122) (DDC AD 655 825)

Table 1 - Stability Characteristics of Blunt Subweapons

Conf. No.	Cross-Section	Fin Scheme and Axes of Rotation	M	I Slugs-Ft ²	Statically Stable	Dynamically Stable	Comments
1	Circular		0.5	3.34×10^{-6}	Yes	Yes	
			0.8	3.34×10^{-6}	Yes	Yes	
2	Circular		0.5	3.49×10^{-6}	Yes	Yes	
			0.8	3.49×10^{-6}	Yes	Yes	
3	Square with slightly rounded corners		0.5	3.08×10^{-6}	Yes	No	Limit cycle of $\pm 10^\circ$
			0.8	3.08×10^{-6}	Yes	No	Limit cycle of $\pm 10^\circ$
4	Square with slightly rounded corners		0.5	3.14×10^{-6}	Yes	No	Limit cycle of $\pm 10^\circ$ Wall effects for $0 > 50^\circ$
			0.8	3.14×10^{-6}	Yes	No	Limit cycle of $\pm 8^\circ$ Wall effects at higher angles

Table 1 - (Continued)

Conf. No.	Cross-Section	Fin Scheme and Axes of Rotation	M	I Slugs-Ft ²	Statically Stable	Dynamically Stable	Comments
5	Square with slightly rounded corners		0.5	3.14 X 10 ⁻⁶	Yes	No	Model oscillates, then autorotates
6	Square with slightly rounded corners		0.5	2.91 X 10 ⁻⁶	Yes	No	Limit cycle of +5°
			0.8	2.91 X 10 ⁻⁶	Yes	No	Limit cycle of +1° (essentially stable)
7	Octagonal		0.5	3.00 X 10 ⁻⁶	No	No	Limit cycle of 0° to -7° Wall effects at higher angles
			0.8	3.00 X 10 ⁻⁶	No	No	Limit cycle of 0° to -9° Wall effects at higher angles
8	Octagonal		0.5	3.26 X 10 ⁻⁶	No	No	Limit cycle of 0° to -5°
			0.8	3.26 X 10 ⁻⁶	No	No	Limit cycle of 0° to -5°

Table 1 - (Continued)

Conf. No.	Cross-Section	Fin Scheme and Axes of Rotation	M	I Slugs-Ft ²	Statically Stable	Dynamically Stable	Comments
9	Octagonal		0.5	3.46 X 10 ⁻⁶	Yes	No	Limit cycle of <u>+5°</u>
			0.8	3.46 X 10 ⁻⁶	Yes	No	Limit cycle of <u>+2°</u>
10	Octagonal		0.5	3.52 X 10 ⁻⁶	Yes	No	Limit cycle of <u>+4°</u>
			0.8	3.52 X 10 ⁻⁶	Yes	→	For $\theta < 20^\circ$, damps out For $\theta > 20^\circ$, limit cycle
11	Clipped Triangle		0.5	3.90 X 10 ⁻⁶	Yes	→	For $\theta < 60^\circ$, damps out For $\theta > 60^\circ$, limit cycle
			0.8	3.97 X 10 ⁻⁶	Yes	→	For $\theta < 20^\circ$, damps out For $\theta > 20^\circ$, limit cycle
12	Clipped Triangle		0.5	3.97 X 10 ⁻⁶	Yes	No	Limit cycle of <u>+2°</u>
			0.8	3.97 X 10 ⁻⁶	Yes	→	For $\theta < 45^\circ$, damps out For $\theta > 45^\circ$, limit cycle

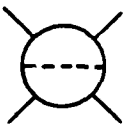
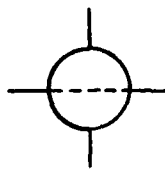
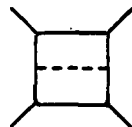
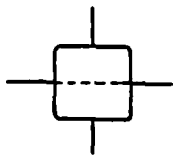
Table 1 - (Continued)

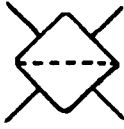
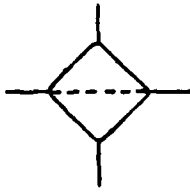
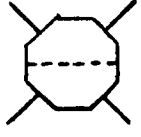
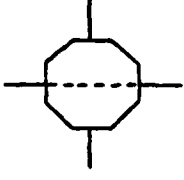

Conf. No.	Cross-Section	Fin Scheme and Axes of Rotation	M	I Slugs-Ft ²	Statically Stable	Dynamically Stable	Comments
13	Clipped Triangle		0.5	3.73 X 10 ⁻⁶	Yes	No	Limit cycle of +2°
			0.8	3.73 X 10 ⁻⁶	Yes	Yes	
14	Irregular Polygon		0.5	3.89 X 10 ⁻⁶	Yes	No	For θ < 30°, limit cycle of +2° For θ > 30°, oscillates then autorotates
			0.8	3.89 X 10 ⁻⁶	Yes	→	For θ < 40°, damps out For θ > 40°, trims at 70° due to wall effects
15	Irregular Polygon		0.5	3.77 X 10 ⁻⁶	Yes	No	For θ < 30°, limit cycle For θ > 30°, oscillates, then autorotates
			0.8	3.77 X 10 ⁻⁶	Yes	→	For θ < 20°, damps out For θ > 20°, limit cycle
16	Irregular Polygon		0.5	3.77 X 10 ⁻⁶	Yes	No	Limit cycle of +2°
			0.8	3.77 X 10 ⁻⁶	Yes	Yes	Wall effects noticeable at θ = 60°

Table 1 - (Continued)

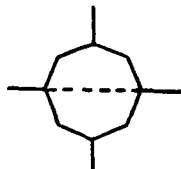
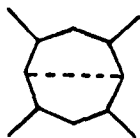
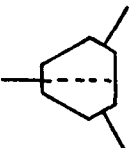
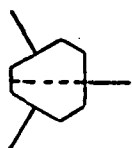

Conf. No.	Cross-Section	Fin Scheme and Axes of Rotation	M	I Slugs-Ft ²	Statically Stable	Dynamically Stable	Comments
17	Irregular Polygon		0.5	3.79×10^{-6}	Yes	No	Limit cycle of $+1^\circ$ (essentially stable)
18	Irregular Pentagon		0.5	3.87×10^{-6}	Yes	Yes	Wall effects are visible, but model overcomes these and damps
			0.8	3.87×10^{-6}	Yes	Yes	Wall effects are visible, but model overcomes these and damps
19	Irregular Pentagon		0.5	3.83×10^{-6}	Yes	No	Small limit cycle for small angles. For $\theta > 30^\circ$, large limit cycle
			0.8	3.83×10^{-6}	Yes	No	Limit cycle of $+5^\circ$
20	Irregular Pentagon		0.5	3.89×10^{-6}	Yes	No	Oscillates, then autorotates

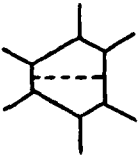
Table 1 - (Concluded)

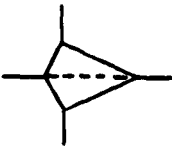
Conf. No.	Cross-Section	Fin Scheme and Axes of Rotation	M	I Slugs-Ft ²	Statically Stable	Dynamically Stable	Comments
21	Irregular Pentagon		0.5	3.33×10^{-6}	Yes	No	Limit cycle of $\pm 5^\circ$
			0.8	3.33×10^{-6}	Yes	No	Limit cycle $\pm 3^\circ$
22	Irregular Pentagon		0.5	3.34×10^{-6}	Yes	No	Limit cycle $\pm 10^\circ$
			0.8	3.34×10^{-6}	Yes	No	Limit cycle $\pm 6^\circ$

Table 2 - Stability Characteristics of Cluster Weapons
(with nose and tail fairings)

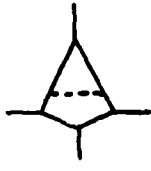
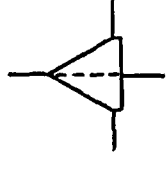
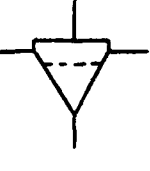
Conf. No.	Cross-Section	Fin Scheme and Axes of Rotation	M	I Slugs-Ft ²	Statically Stable	Dynamically Stable	Comments
23	Circular		0.5	1.34×10^{-6}	No	Yes	Trims at 10°
			0.8	1.34×10^{-6}	No	Yes	Trims at 12°
24	Circular		0.5	1.30×10^{-6}	No	No	Limit cycle of 5° to 20°
			0.8	1.30×10^{-6}	Yes	No	Limit cycle of +100°
25	Square with rounded corners Width = 0.75" Corners = 0.188"R		0.5	1.16×10^{-6}	No	No	Oscillates between 50° and 80°. Wall effects
			0.8	1.16×10^{-6}	No	No	Oscillates between 45° and 85°
26	Square with rounded corners Width = 0.75" Corners = 0.188"R		0.5	1.14×10^{-6}	No	No	Oscillates between 40° and 90°
			0.8	1.14×10^{-6}	No	No	Oscillates between 40° and 90°

Table 2 - (Continued)

Conf. No.	Cross-Section	Fin Scheme and Axes of Rotation	M	I Slugs-Ft ²	Statically Stable	Dynamically Stable	Comments
27	Square with rounded corners Width = 0.75" Corners = 0.188"R		0.5	1.11 X 10 ⁻⁶	Yes	No	Limit cycle of <u>+110°</u>
28	Square with rounded corners Width = 0.75" Corners = 1/64"R		0.5	1.16 X 10 ⁻⁶	Yes	No	Oscillates, then autorotates
29	Square with rounded corners Width = 0.75" Corners = 1/64"R		0.5	1.11 X 10 ⁻⁶	Yes	No	Oscillates, then autorotates
30	Square with rounded corners Width = 0.75" Corners = 1/64"R		0.5	1.10 X 10 ⁻⁶	Yes	No	Oscillates, then autorotates

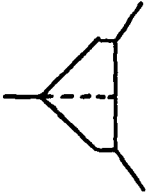
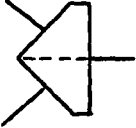
Table 2 - (Continued)

Conf. No.	Cross-Section	Fin Scheme and Axes of Rotation	M	I Slugs-Ft ²	Statically Stable	Dynamically Stable	Comments
31	Square with rounded corners Width = 0.78" Corners = 1/64"R		0.5	1.17 X 10 ⁻⁶	Yes	No	Oscillates, then autorotates
32	Clipped Square		0.5	1.16 X 10 ⁻⁶	Yes	No	Limit cycle of ±110°
33	Clipped Square		0.5	1.11 X 10 ⁻⁶	Yes	No	Oscillates, then autorotates
34	Clipped Square		0.5	1.11 X 10 ⁻⁶	Yes	No	Limit cycle of ±100°
			0.8	1.11 X 10 ⁻⁶	Yes	No	Oscillates, then autorotates

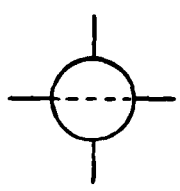
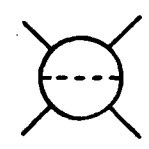
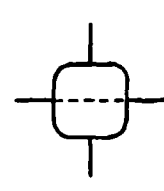
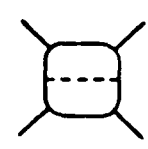
Table 2 - (Continued)

Conf. No.	Cross-Section	Fin Scheme and Axes of Rotation	M	I Slugs-Ft ²	Statically Stable	Dynamically Stable	Comments
35	Clipped Square		0.5	1.16 X 10 ⁻⁶	Yes	No	Oscillates, then autorotates
36	Hexagonal		0.5	1.17 X 10 ⁻⁶	No	Yes	Trims at 3°
			0.8	1.17 X 10 ⁻⁶	Yes	No	Limit cycle of +80°
37	Hexagonal		0.5	1.24 X 10 ⁻⁶	Yes	No	Limit cycle of +3°
			0.8	1.24 X 10 ⁻⁶	Yes	No	Limit cycle of +15°
38	Hexagonal		0.5	1.14 X 10 ⁻⁶	Yes	No	Limit cycle of +22°
			0.8	1.14 X 10 ⁻⁶	Yes	No	Limit cycle of +90°

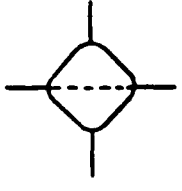
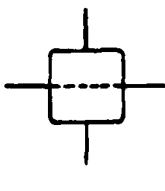
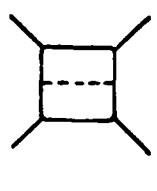
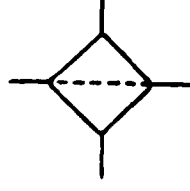
Table 2 - (Continued)

Conf. No.	Cross-Section	Fin Scheme and Axes of Rotation	M	I Slugs-Ft ²	Statically Stable	Dynamically Stable	Comments
39	Hexagonal		0.5	1.16 X 10 ⁻⁶	Yes	No	Limit cycle of +90°
40	Hexagonal		0.5	1.24 X 10 ⁻⁶	No	Yes	Trims at 8°
			0.8	1.24 X 10 ⁻⁶	No	Yes	Trims at 10°
41	Hexagonal		0.5	1.17 X 10 ⁻⁶	No	No	Limit cycle of -10° to -16°
			0.8	1.17 X 10 ⁻⁶	Yes	No	Large limit cycle
42	Octagonal		0.5	1.28 X 10 ⁻⁶	No	No	Limit cycle of 5° to 10°
			0.8	1.28 X 10 ⁻⁶	No	No	Limit cycle of -12° to -17°

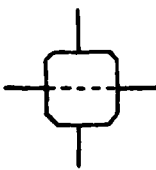
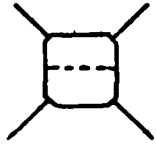
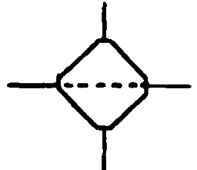
Table 2 - (Continued)

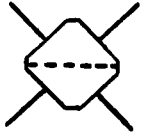
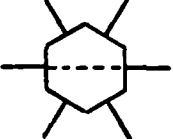
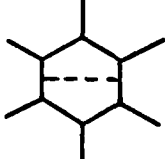
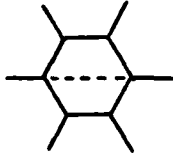

Conf. No.	Cross-Section	Fin Scheme and Axes of Rotation	M	I Slugs-Ft ²	Statically Stable	Dynamically Stable	Comments
43	Octagonal		0.5	1.35×10^{-6}	No	Yes	Trims at 14°
			0.8	1.35×10^{-6}	No	Yes	Trims at 16°
44	Octagonal		0.5	1.30×10^{-6}	Yes	Yes	
			0.8	1.30×10^{-6}	Yes	Yes	
45	12 Sided Regular Polygon		0.5	1.39×10^{-6}	No	Yes	Trims at 6°
			0.8	1.39×10^{-6}	No	Yes	Trims at 8°
46	12 Sided Regular Polygon		0.5	1.39×10^{-6}	No	Yes	Trims at -12°
			0.8	1.39×10^{-6}	No	No	Oscillates from 5° to 10°

Table 2 - (Concluded)

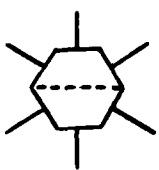
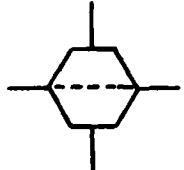
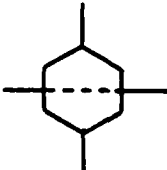
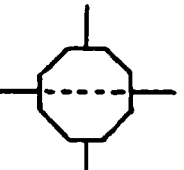
Conf. No.	Cross-Section	Fin Scheme and Axes of Rotation	M	I Slugs-Ft ²	Statically Stable	Dynamically Stable	Comments
47	12 Sided Regular Polygon		0.5	1.42×10^{-6}	No	Yes	Trims at 4°
			0.8	1.42×10^{-6}	No	Yes	Trims at 5°
48	12 Sided Regular Polygon		0.5	1.40×10^{-6}	No	No	Oscillates from -10° to -15°
			0.8	1.40×10^{-6}	No	No	Oscillates from 10° to 20°

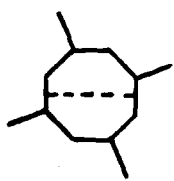
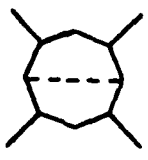
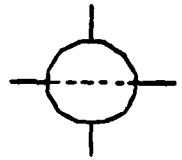
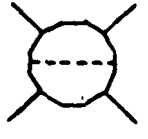
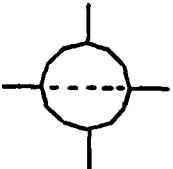

(a) Clusters with nose and tail fairings

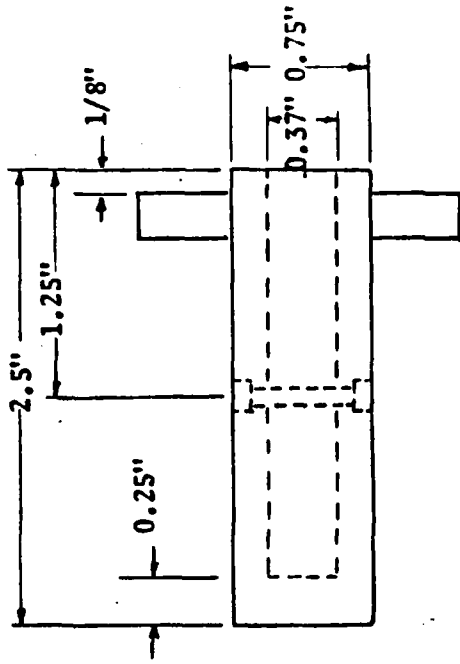
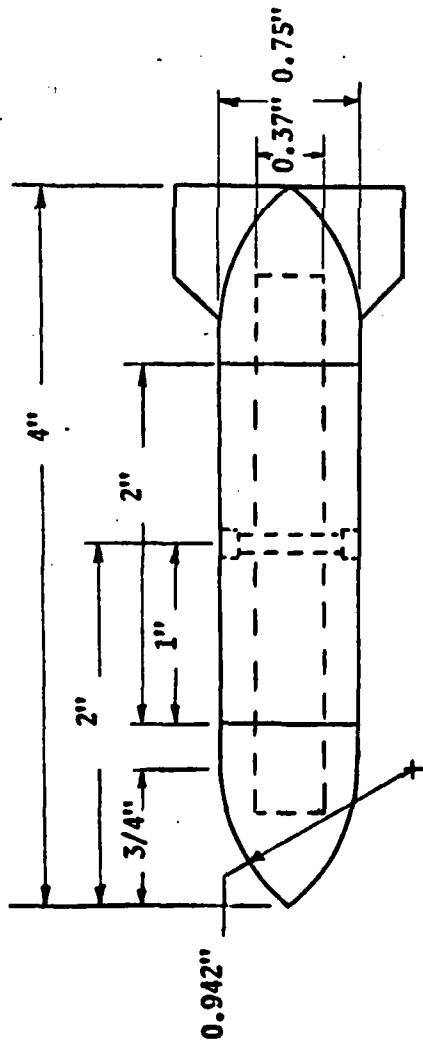

(b) Blunt Subweapons

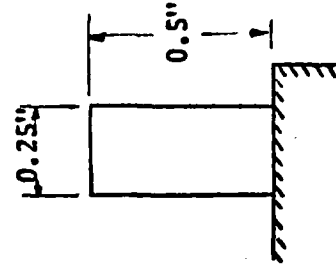
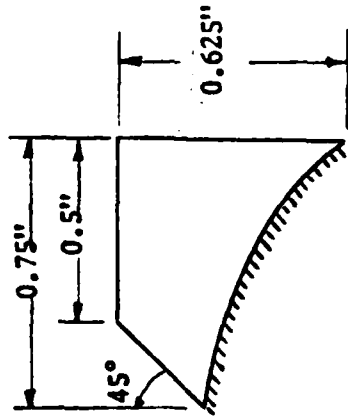
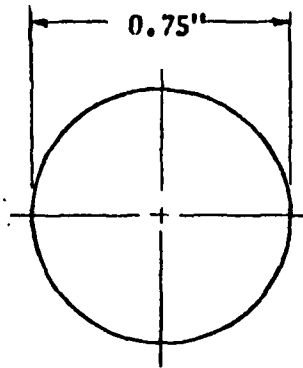
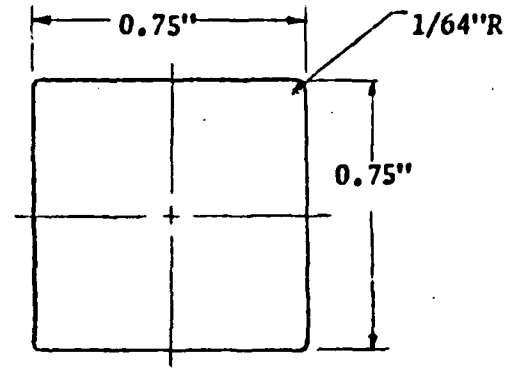

Figure 1 - Longitudinal Geometric Characteristics



Circular
(Configurations 1-2)



**Square with Slightly
Rounded Corners**
(Configurations 3-6)

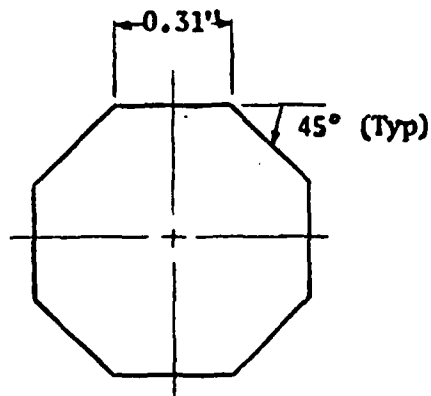

Regular Octagon
(Configurations 7-10)

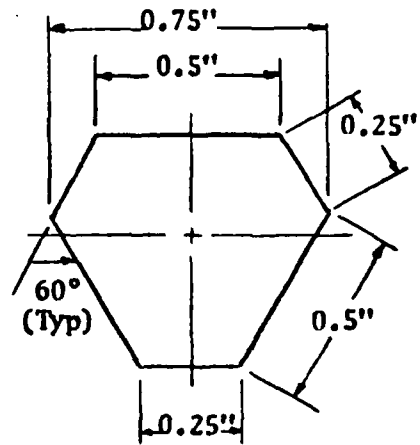

Clipped Triangle
(Configurations 11-13)

Figure 2 - Cross-Sectional Characteristics of Blunt Subweapons

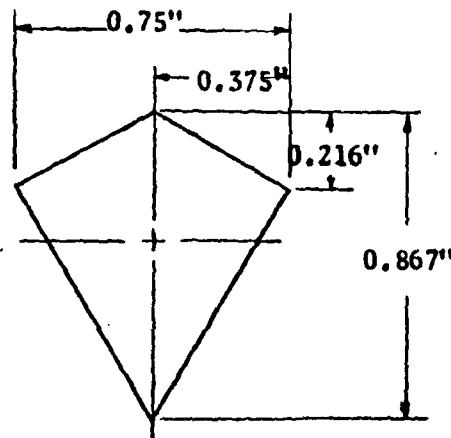

Irregular Polygon
(Configurations 14-17)

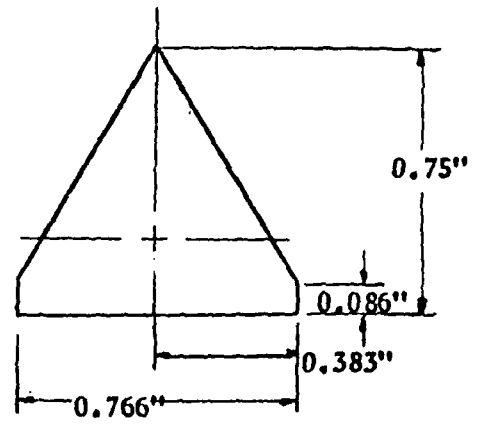

Irregular Polygon
(Configurations 18-20)

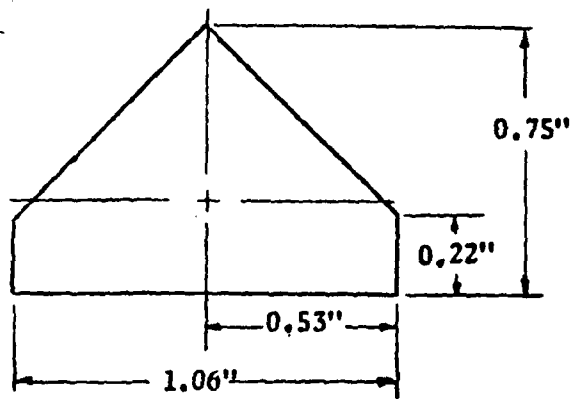

Irregular Pentagon
(Configurations 21-22)

Figure 2 - (Concluded)

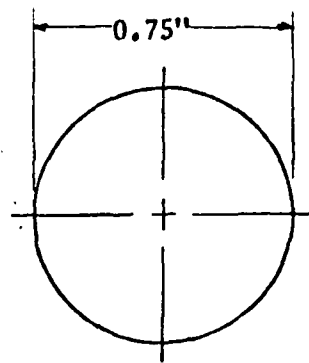

Circular
(Configurations 23-24)

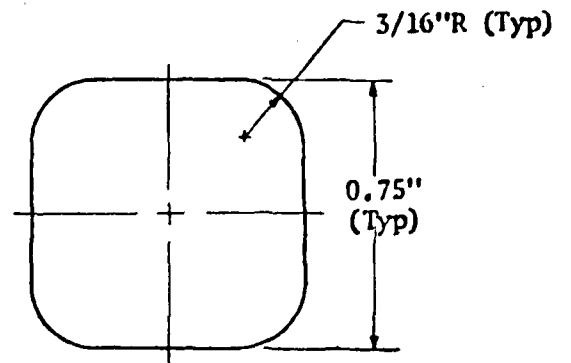

Square with
Rounded Corners
(Configurations 25-27)

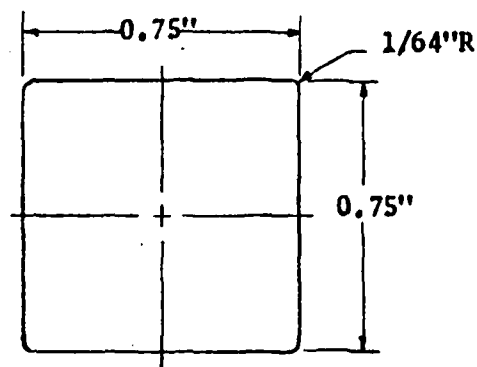

Square with Slightly
Rounded Corners
(Configurations 28-31)

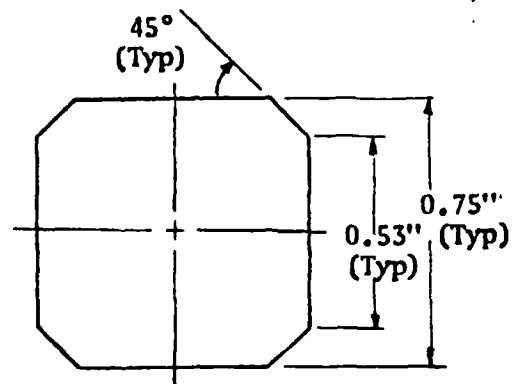

Clipped-Square
(Configurations 32-35)

Figure 3 - Cross-Sectional Characteristics of Cluster Weapons

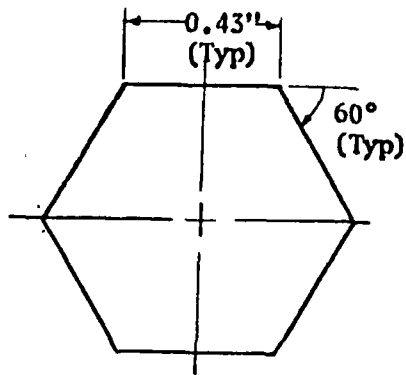

Hexagonal
(Configurations 36-41)

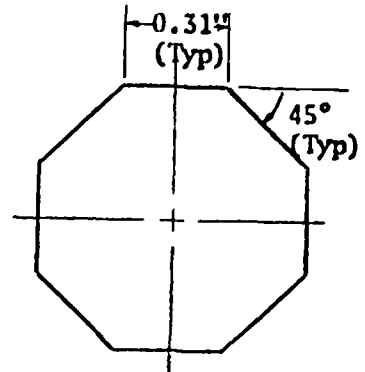

Octagonal
(Configurations 42-44)

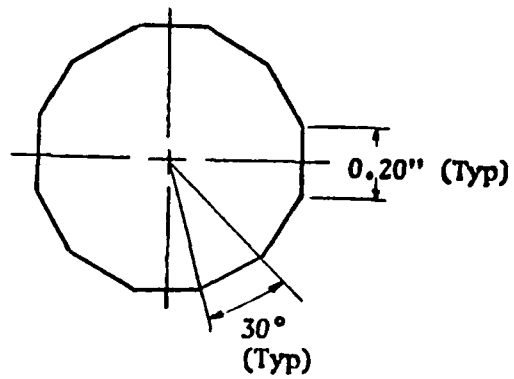

Twelve-Sided
Regular Polygon
(Configurations 45-48)

Figure 3 - (Concluded)

NAVY RESEARCH AND DEVELOPMENT CENTER
WASHINGTON, D. C. 20360

PRELIMINARY STABILITY STUDIES OF SHAPES SUITABLE FOR HIGH DENSITY,
CLUSTERED PACKAGING

REPORT NOTE

REPORTING OFFICER (Last name, initials, first name)

William C. Beckwith

REPORT DATE

February 1968

6. TOTAL NO. OF PAGES

21

7. NO. OF FIGS.

8. CONTRACT OR GRANT NO.

EP 013 0101

9. ORIGINATOR'S REPORT NUMBER(S)

PROJECT NO.

NSRDC 651-231

10. REPORT NO. (AL-80)

11. OTHER REPORT NO(S) (Any other numbers that may be assigned to this report)

12. DISTRIBUTION STATEMENT

GROUP 1

UNLIMITED

Cleared 3/60

13. SUPPLEMENTARY NOTES

14. SPONSERING MILITARY ACTIVITY

Chief of Naval Material
Department of the Navy
Washington, D. C. 20360

15. ABSTRACT

Preliminary stability studies were conducted on shapes suitable for high density, clustered packaging. One-degree-of-freedom, free oscillation tests were conducted in the 7- by 10-inch Transonic Wind Tunnel at Mach numbers of 0.50 and 0.80. Blunt subweapons, with rectangular fins as stabilizing devices, were tested as well as clusters with nose fairings, tail fairings, and "clipped-delta" fins. The results of this study are qualitatively presented in tabular form. The only shape which was both statically and dynamically stable for all modes was a cylindrical blunt body.

Classification

Security Classification