

AD-A081 768

NAVAL POSTGRADUATE SCHOOL MONTEREY CA
VALIDATION OF AN AMBIENT AIR QUALITY MODEL FOR NAVAL AIR OPERAT--ETC(U)
DEC 79 T S DOUGLAS

F/G 13/2

UNCLASSIFIED

ML

1 of 2
AD
ADDITION

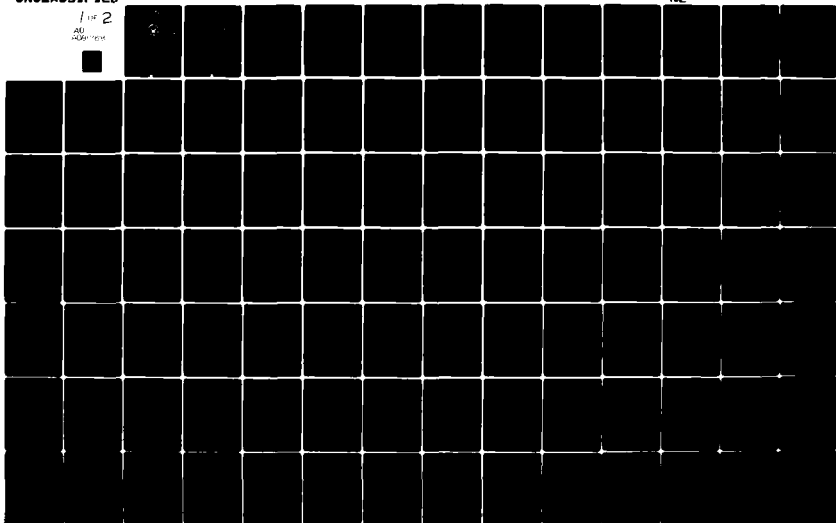

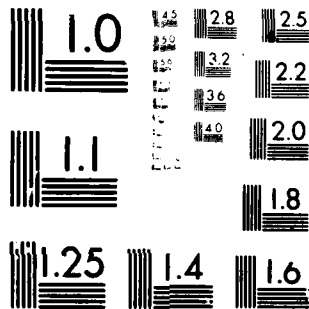

MICROCOPY RESOLUTION TEST CHART
NATIONAL BUREAU OF STANDARDS-1963-A

LEVEL #

2

NAVAL POSTGRADUATE SCHOOL
Monterey, California

ADA081768



DTIC
SELECTE
MAR 14 1980
S D C

THESIS

VALIDATION OF AN AMBIENT
AIR QUALITY MODEL
FOR
NAVAL AIR OPERATIONS

by

Terry Scott Douglas

December 1979

Thesis Advisor:

D. W. Netzer

Approved for public release, distribution unlimited.

80 3 10 010

UNCLASSIFIED

SECURITY CLASSIFICATION OF THIS PAGE (When Data Entered)

REPORT DOCUMENTATION PAGE		READ INSTRUCTIONS BEFORE COMPLETING FORM
1. REPORT NUMBER	2. GOVT ACCESSION NO.	3. RECIPIENT'S CATALOG NUMBER
4. TITLE (and Subtitle) <u>VALIDATION OF AN AMBIENT AIR QUALITY MODEL FOR NAVAL AIR OPERATIONS</u>		5. TYPE OF REPORT & PERIOD COVERED Master's Thesis December 1979
7. AUTHOR(s) 10 Terry Scott Douglas		6. PERFORMING ORG. REPORT NUMBER
9. PERFORMING ORGANIZATION NAME AND ADDRESS Naval Postgraduate School Monterey, California 93940		8. CONTRACT OR GRANT NUMBER(s)
11. CONTROLLING OFFICE NAME AND ADDRESS Naval Air Propulsion Center Trenton, New Jersey 09628		10. PROGRAM ELEMENT, PROJECT, TASK AREA & WORK UNIT NUMBERS N6237679WR00014
14. MONITORING AGENCY NAME & ADDRESS (if different from Controlling Office) Naval Postgraduate School Monterey, California 93940 12, 13, 14		12. REPORT DATE Dec 1979 13. NUMBER OF PAGES 130
16. DISTRIBUTION STATEMENT (of this Report) Approved for public release, distribution unlimited		15. SECURITY CLASS. (of this report) Unclassified
17. DISTRIBUTION STATEMENT (of the abstract entered in Block 20, if different from Report)		15a. DECLASSIFICATION/DOWNGRADING SCHEDULE
18. SUPPLEMENTARY NOTES		
19. KEY WORDS (Continue on reverse side if necessary and identify by block number) Air Pollution Aircraft Model		
20. ABSTRACT (Continue on reverse side if necessary and identify by block number) An initial validation of an Air Quality Assessment Model for Naval air operations was conducted at NAS Miramar, CA. A previously developed model was updated to appropriately represent 1978/79 operations and then evaluated for prediction sensitivity to variations in meteorological and dispersion model parameters. A joint effort with the Naval Air Propulsion Center, the Environmental Protection Agency/Northrup Services, Inc. and PMTC, Pt. Mugu		

DD FORM 1473
1 JAN 73
(Page 1)

EDITION OF 1 NOV 68 IS OBSOLETE
S/N 0102-014-6601

1

UNCLASSIFIED 251450
SECURITY CLASSIFICATION OF THIS PAGE (When Data Entered)

UNCLASSIFIED

SECURITY CLASSIFICATION OF THIS PAGE/When Data Entered

was conducted to obtain detailed data over a one-week period. Comparison of model predictions with the limited initial measured concentration data indicated that: (1) predicted CO concentrations were in good agreement with measurement, (2) predicted NOX concentrations from aircraft idle/taxi operations were too low, and (3) predicted total hydrocarbons and particulate concentrations were too high for aircraft idle/taxi operations and too low for environ sources.

Accession For	
RTI	<input checked="" type="checkbox"/>
ADAMS	<input type="checkbox"/>
Unannounced	<input type="checkbox"/>
Justification	
FOIA	
Exemption	
Authority	
Comments	
or	
A	

DD Form 1473
1 Jan 73
S/N 0102-014-6601

2

UNCLASSIFIED

SECURITY CLASSIFICATION OF THIS PAGE/When Data Entered

Approved for public release, distribution unlimited

VALIDATION OF AN AMBIENT
AIR QUALITY MODEL
FOR
NAVAL AIR OPERATIONS

by

Terry Scott Douglas
Lieutenant, United States Navy
B. S., United States Naval Academy, 1970

Submitted in partial fulfillment of the
requirements for the degree of

MASTER OF SCIENCE IN AERONAUTICAL ENGINEERING

from the

NAVAL POSTGRADUATE SCHOOL
December 1979

Author

Terry Scott Douglas

Approved by:

Robert W. Hedges

Thesis Advisor

Max F. Plotter

Chairman, Department of Aeronautics

William M. Tolles

Dean of Science & Engineering

ABSTRACT

An initial validation of an Air Quality Assessment Model for Naval air operations was conducted at NAS Miramar, CA. A previously developed model was updated to appropriately represent 1978/79 operations and then evaluated for prediction sensitivity to variations in meteorological and dispersion model parameters. A joint effort with the Naval Air Propulsion Center, the Environmental Protection Agency/Northrup Services, Inc. and PMTC, Ft. Mugu was conducted to obtain detailed data over a one-week period. Comparison of model predictions with the limited initial measured concentration data indicated that; (1) predicted CO concentrations were in good agreement with measurement, (2) predicted NOX concentrations from aircraft idle/taxi operations were too low, and (3) predicted total hydrocarbons and particulate concentrations were too high for aircraft idle/taxi operations and too low for environmental sources.

TABLE OF CONTENTS

I.	INTRODUCTION-----	9
II.	OVERALL MODEL VALIDATION EFFORT-----	14
III.	NAS MIRAMAR INTENSIVE DATA ACQUISITION-----	16
IV.	AQAM MODIFICATIONS AND SENSITIVITY STUDY-----	25
A.	MODEL MODIFICATIONS-----	25
B.	SENSITIVITY STUDY PARAMETERS AND PREDICTIONS---	26
C.	EFFECT OF METEOROLOGICAL PARAMETERS ON MAXIMUM RECEPTOR CONCENTRATIONS-----	32
1.	Stability Category-----	34
2.	Lid Height-----	34
3.	Wind Speed-----	35
4.	Wind Direction-----	35
D.	EFFECT OF METEOROLOGICAL PARAMETERS ON CONCENTRATIONS AT SPECIAL RECEPTORS-----	35
1.	Stability Category-----	36
2.	Lid Height-----	41
3.	Wind Speed-----	41
4.	Wind Direction-----	41
5.	Special Receptor Locations-----	42
E.	EFFECT OF SPECIFIED AREA SOURCE SIZE ON RECEPTOR CONCENTRATIONS-----	44
F.	VARIATION OF JET PENETRATION LENGTH, INITIAL LINE SOURCE DIMENSIONS AND DISPERSION PARAMETERS-----	45
G.	CONCLUSIONS-----	47

V. COMPARISON OF AQAM PREDICTIONS WITH DATA FROM THE INTENSIVE STUDY-----	48
A. VALIDATION REQUIREMENTS-----	48
B. DATA REDUCTION AND MODEL INPUTS-----	50
C. DISCUSSION OF RESULTS-----	58
1. CO Emissions-----	59
2. NOX Emissions-----	64
3. THC Emissions-----	66
4. PT Emissions-----	67
D. CONCLUSIONS AND RECOMMENDATIONS-----	70
APPENDIX A Special Receptor Concentrations for Sensitivity Study-----	72
APPENDIX B CO and PT Concentration Profiles from Aircraft Sources (Sensitivity Study)-----	83
APPENDIX C CO and PT Concentration Profiles from Aircraft Sources (Intensive Study)-----	105
LIST OF REFERENCES-----	128
INITIAL DISTRIBUTION LIST-----	130

LIST OF TABLES

I.	Monitoring Station Locations-----	18
II.	Aircraft Activity Monitoring Times (Local)-----	20
III.	Special Receptor Locations-----	27
IV.	Meteorology for Sensitivity Study-----	28
V.	Aircraft Activity for Sensitivity Study-----	30
VI.	Maximum Receptor Concentrations-----	33
VIIa.	Special Receptor Concentrations (Stability Category Variation)-----	37
VIIb.	Special Receptor Concentrations (Lid Height Variation)-----	38
VIIc.	Special Receptor Concentrations (Wind Speed Variation)-----	39
VIIId.	Special Receptor Concentrations (Wind Direction Variation)-----	40
VIII.	Difference Factors in Special Receptor Concentrations-----	43
IX.	AQAM Runs Made for Intensive Study-----	51

LIST OF FIGURES

1.	Grid Identification at NAS Miramar-----	17
2.	Takeoff Data Sheet-----	21
3.	Landing Data Sheet-----	22
4.	Hot Refuel Sequence Data Sheet-----	23
5.	Pit Refuel Sequence Data Sheet-----	24
6a.	Meteorological Conditions at NAS Miramar vs. Time of Day (1 Aug)-----	53
6b.	Meteorological Conditions at NAS Miramar vs. Time of Day (2 Aug)-----	54
6c.	Meteorological Conditions at NAS Miramar vs. Time of Day (3 Aug)-----	55
6d.	Meteorological Conditions at NAS Miramar vs. Time of Day (6 Aug)-----	56
6e.	Meteorological Conditions at NAS Miramar vs. Time of Day (7 Aug)-----	57
7.	Measured Versus Predicted Hourly Average CO Concentrations for Intensive Study-----	60
8.	Predicted CO Concentration Profiles Along 8 km. Y-Coordinate-----	63
9.	Measured Versus Predicted Hourly Average NOX Concentrations for Intensive Study-----	65
10.	Measured Versus Predicted Hourly Average THC Concentrations for Intensive Study-----	68
11.	Measured Versus Predicted Hourly Average PT Concentrations for Intensive Study-----	69

ACKNOWLEDGEMENT

Successful validation efforts occur as a result of teamwork. It is most rewarding to have been a member of a professional group of people enjoined for a single purpose. Individuals from NAPC, EPA, NSI and PMTC all provided the required technical expertise in their specific areas.

The one individual most instrumental in guiding the direction of this study and providing the necessary assistance in analyzing the results was Professor D. W. Netzer. His tireless efforts and attentive support created a pleasant yet productive environment in which to complete this work.

I. INTRODUCTION

In recent years several mathematical models have been developed to predict the atmospheric dispersion of pollutants emitted from aircraft-related activities at and around airports. These models have used the steady state Gaussian plume formulation. The Gaussian formulation is used because it is adaptable to distances and pollutant travel times associated with airports. An early contract sponsored by the U.S. Environmental Protection Agency (EPA) resulted in a model being developed by the Northern Research and Engineering Corporation (Ref. 1). This model was later modified by GEOMET, Inc. (Ref. 2), and dealt specifically with civilian airport operations. A more recent model has been developed by Argonne National Laboratory (ANL) for the USAF and was termed the Air Quality Assessment Model for Air Force Operations (AQAM) (Ref. 3). This computer model was based upon an earlier TRW model, the Air Quality Display Model (Ref. 4).

Each of the models utilizes a method for solution of diffusion equations assuming Gaussian dispersion in both the horizontal and vertical directions. Gaussian formulation in air quality model calculations requires meteorological inputs including stability of the atmosphere, mixing layer height, and wind direction and speed. Detailed pollution source data are also required. The resultant models consisted of emission and dispersion programs. AQAM included three major parts, a Source Inventory model which yields annual emission at an

activity by source, a Short Term dispersion model which performs hourly-averaged calculations using input dispersion parameters and a Long Term dispersion model. The models predict average steady-state concentrations during the specified time interval over a specified grid surrounding the airport.

Model verifications have to be conducted to test the algorithms and plume dispersion equations. Initial efforts to validate AQAM were begun by the Air Force at Williams AFB, Arizona. Williams AFB was chosen because it was a high traffic-volume, military airfield where accurate statistics would be available. These statistics included aircraft type, mix, and activity schedules from which emissions input data could be calculated (Ref. 5). The objectives of the validation effort were three-fold:

1. Collect a data base of airport-related air quality measurements to evaluate the Air Force AQAM model.
2. Determine the impact (if any) of airport-related activity on local (5 km radius) air quality.
3. Conduct a series of special studies to provide information on horizontal and vertical dispersion to supplement any model revision by ANL (Ref. 6).

The Navy became interested in the Argonne model capabilities relative to Naval Air operations. Under sponsorship of the Naval Air Propulsion Center (NAPC) Trenton, N.J., the Naval Postgraduate School (NPS), Monterey, Ca., obtained copies of both the Source Inventory and the Short Term models of AQAM

for evaluation and adaptation to Navy operations. Upon completion of modifications, a validation effort similar to the one at Williams AFB was planned at NAS Miramar, California.

The Source Inventory Program, as originally received from ANL, computes annual emissions of three types of sources: aircraft, airbase (non-aircraft) and environment (off-airbase). Each of these types is further reduced by geometric configuration to either a point, line or area source. Data are input to the Source Inventory program relative to the type and size of source, location of the emission plume in three-dimensional space and the mass emission rate of each pollutant emitted by the source. The model input is often comprehensive and voluminous, leaving a great margin for possible error. The program calculates annual emissions and provides a qualitative ranking of the contributions to the ambient air pollution of any individual source. It also prepares a data bank containing source characteristics, annual emission rates and temporal distribution activity for utilization by the Short Term program.

The Short Term program receives the above compiled annual results and calculates the dispersion of generated pollutants over a specified receptor grid during a given hour, day and month utilizing average meteorological data input for that hour (Ref. 7). For point and area sources this is accomplished by using initial source dimensions and meteorological stability criteria to project a pseudo-upwind point source. Line sources are generated along the route of travel of the source vehicles.

The Short Term model utilizes a line dispersion theory developed by ANL. The line of finite cross-section is segmented into shorter lines, or "puffs", which are then dispersed from pseudo-upwind line sources in much the same manner as point and area sources (Ref. 3,8).

Principle modifications to AQAM were required by the Navy due to differences in flight operations between the Navy and Air Force. Subroutines were added to AQAM to account for Visual Flight Rule (VFR) approaches including aircraft entry break above the runway, Navy touch-and-go cycles, field carrier landing practices (FCLP), takeoff delays, and hot refueling (refueling of aircraft while engines are operating). Also AQAM was expanded to handle helicopter operations. It should be noted that modifications were only made to subroutines involving aircraft sources. Airbase and environ source data remain relatively consistent from base to base whether Navy, Air Force or civilian. The Short Term portion of AQAM was modified to calculate dispersion of pollutants over 412 grid receptors rather than the Air Force's 312 receptors. This was done so that a larger off airbase area could be included in the analysis. Finally, Navy aircraft engines and fuel types are often different than those of the Air Force and, consequently, aircraft performance data and emissions data had to be input to reflect the changes. A plot routine was also incorporated into AQAM so that predicted pollutant distribution patterns could be more readily observed (Ref. 9).

The aforementioned model verification performed by the Air Force at Williams AFB involved 13 months of continuous air monitoring during the period June 1976 through June 1977. Air quality data were collected at five ground stations and meteorological data were taken routinely at the base weather station. Aircraft operations data and airbase and environ source information were then input to AQAM and predicted values of pollutant concentrations were compared with observed, or measured data from the monitoring stations. Preliminary results have indicated that a reasonable correlation exists between predicted and observed hourly pollutant levels (Ref. 10).

The Air Force effort included a wide range of meteorological conditions collected over a long period of time. It was decided to concentrate the Navy validation effort on a specific meteorological "window" which would be reasonably stable for several days and which would occur when a large amount of aircraft activity occurred. The latter was necessary in order to minimize the problem inherent with high background pollution levels. Specifically, it was desired to perform the validation effort at NAS Miramar, CA and to obtain more detailed data relative to (1) aircraft taxi and refueling operations, (2) hourly aircraft flight activity, and (3) meteorology.

Once the Navy modifications were completed and input data were obtained for NAS Miramar, it was necessary to determine

the sensitivity of the model predictions to the input meteorological and operational conditions and to certain dispersion model parameters. An initial model sensitivity study was performed using the Navy version of AQAM and 1975 activity at NAS Miramar as a representative data base (Ref. 9).

The purposes of the present study were (1) to update the data in the Source Inventory program of AQAM in order to represent 1978/1979 operations at NAS Miramar and (2) to compare the predicted and measured levels of pollutant concentrations for the purpose of validating the Short Term program of AQAM. A necessary component of the validation effort was the conducting of an updated model prediction sensitivity study.

II. OVERALL MODEL VALIDATION EFFORT

The Navy version of the AQAM model validation effort was initiated by the Naval Air Propulsion Center (NAPC). NAPC provided the funding and necessary program coordination as well as technical assistance in selection of the monitoring site locations and the required data acquisition. NAS Miramar was chosen because it had the largest number of flight operations of any NAS and because it had been used in previous work performed by the Naval Postgraduate School in developing the Navy version of AQAM.

The overall objectives of the NAPC program were to:

- a. validate the AQAM model,
- b. document the effects of aircraft operations on air quality, and

- c. assess the possibility of using AQAM (as an alternative to an expensive monitoring program) to determine the effects of aircraft operations on air quality at other NASs (Ref. 11).

The program was divided into two related parts. The first part is currently ongoing and consists of a one year continuous monitoring study. Air quality is being measured 24 hours a day using an automated data acquisition system. This effort is directed primarily at objective (b) noted above. The second part consists of two special studies, each one-week in duration. The latter studies are intensive in nature with detailed operational, meteorological and pollution concentration data being collected. These studies are directed primarily at objectives (a) and (c) above. The first special study took place in August 1979 and data received from that week were used in the model validation discussed herein. The second special study is scheduled for the spring of 1980. The two periods were chosen to occur during distinctly different meteorological conditions, especially lid height and stability category. Organizations involved in the special study and individual responsibilities of each included:

- a. Northrup Services Incorporated (NSI) contracted by EPA: Air quality monitoring and data reduction to provide hourly averaged pollutant levels.
- b. Pacific Missile Test Center (PMTTC): Meteorological measurements and data reduction to provide hourly

averaged weather conditions throughout the receptor grid.

- c. NAPC/NPS: Aircraft activity monitoring.
- d. NPS: Reduction of aircraft activity data for input into AQAM, model predictions using items b. and c. above, comparison of predictions with measured values (item a. above).

III. NAS MIRAMAR INTENSIVE DATA ACQUISITION

Planning the special study for validation of AQAM began with identifying both the emittants to be monitored to best characterize dispersion and, as previously mentioned, locating appropriate monitoring stations.

The major pollutants in aircraft engine exhausts include particulates/smoke (PT), carbon monoxide (CO), unburned hydrocarbons (HC) and oxides of nitrogen (NOX). The relative amounts emitted depend primarily upon the engine thrust setting. In addition, sulfur oxide emissions (SOX) are often significant from industrial and domestic furnaces. Therefore, CO, HC, NOX, PT and SOX were selected as the pollutants to characterize emissions of both aircraft and airbase related activity. Figure 1 identifies the grid system used to locate the receptors in AQAM. The grid spacing was 1 km. and the x-y coordinates varied from (0,0) to (24,15) representing 400 separate receptor locations.

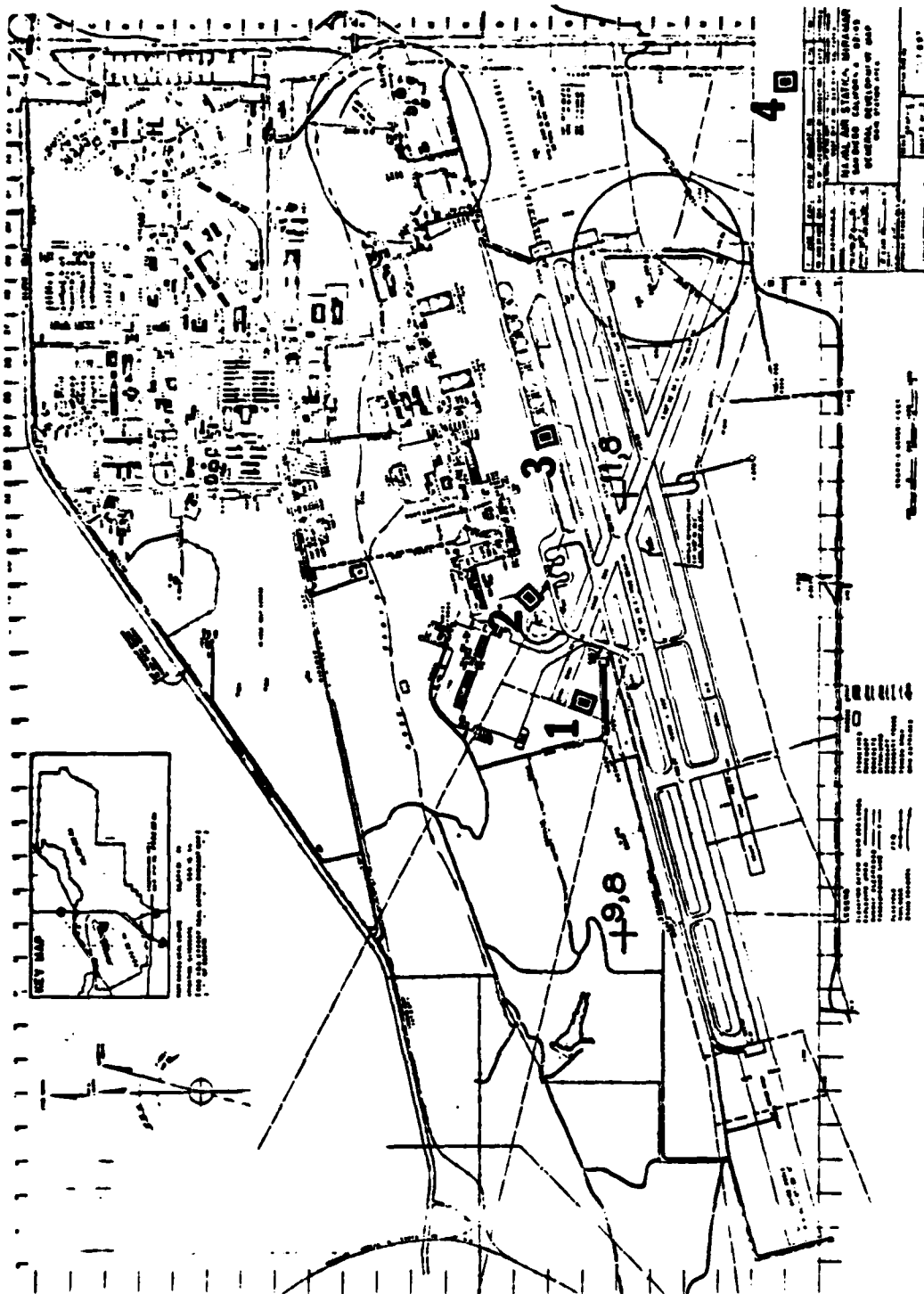

GRID IDENTIFICATION AT NAS MIRAMAR

FIGURE 1

Locating measuring stations where continuous-air-monitoring instruments would be placed was of prime importance in the validation effort. The behavior of the model predictions at a particular receptor will depend to a great extent on its location relative to numerous sources throughout the receptor grid, especially those located upwind. To validate the model, it was important to compare air quality samples at locations where the airbase and aircraft contributions were large relative to background levels of pollution. Ultimate placement of the stations assumed a dominant wind from the WNW (292°) as advised by PMTC.

Up to 12 special receptor locations can be input to the Short Term program. Special receptor locations were assigned to each of the four pollution monitoring stations as indicated in Table I. They are also identified in Figure 1.

TABLE I
MONITORING STATION LOCATIONS

TRAILER NUMBER	GRID COORDINATES	SPECIAL RECEPTOR NUMBER IN AQAM
1	10.01, 8.24	401
2	10.52, 8.46	402
3	11.24, 8.35	406
4	12.82, 7.31	410

The intended use of trailer 1 was to determine background levels of pollution upwind of aircraft/airbase sources.

Trailer 2 was located just downwind of the hot refueling site.

Trailer 3 was situated just upwind of the hot refueling pits. It was also downwind of the hot refueling area. Trailer 4 was located well downwind at the outer boundary of NAS Miramar.

During the planning stage, NSI made equipment preparations for each trailer site for the air quality monitoring experiment. PMTC analyzed the meteorological history for the San Diego area to determine the best time period for the special study. Optimum weather conditions for validation were considered to consist of a moderate wind coming from the 290 degree direction, a Turner stability category of 2-3, and a moderate lid height (mixing layer depth) of 400-500 meters. It was desirable to have relatively constant weather conditions for the week of intensive data acquisition. This would allow the dispersion model to be validated with multiple tests in which aircraft operations varied but weather remained approximately fixed. The week of 1-7 August 1979 was chosen as the most feasible for meeting these objectives for the first intensive study.

Operating procedures for the week proceeded on a previously planned routine. Specific tasks performed by NSI (pollution monitoring) and PMTC (meteorological monitoring) will be presented by those activities under separate cover. NPS and NAPC personnel monitored the detailed aircraft activity in accordance with the time schedule listed in Table II.

TABLE II
AIRCRAFT ACTIVITY MONITORING TIMES (LOCAL)

1 AUG	1300 - 1600
2 AUG	1000 - 1230 1400 - 1700
3 AUG	0800 - 1230
6 AUG	0900 - 1230 1330 - 1630
7 AUG	0830 - 1100 1330 - 1630

Observation of aircraft activity was performed/recorded from three locations -- the control tower, the hot refueling site (octagon) and the refueling pits.

The functions performed in the control tower involved (1) timing the sequences of every aircraft on departure from initial startup to takeoff, (2) timing the sequences of every aircraft on recovery from entry into the airport traffic area (defined here as having a three-mile radius) to landing and taxi to the refueling area. Also, the parking areas and taxiways used by each aircraft and the type of landing performed (VFR, IFR) were monitored. Data sheets used to record the aircraft activities observed from the control tower are presented in figures 2 and 3.

Data collected at the hot refueling sites (octagon) and refueling pits included time-in-mode, amount of fuel taken, and aircraft type (see data sheets in figures 4 and 5).

TAKEOFF DATA SHEET

DUTY RUNWAY _____ WIND _____ TIME _____

register/time

Side number _____ Aircraft type _____

Parking area _____

Commence sequence 0/0

Start complete _____ / _____

Taxi complete _____ / _____
(holding at runway)
(engine check complete)

Takeoff complete _____ / _____

EVOLUTION (check one)

Takeoff and depart area _____

FCLP _____ number _____

Touch and go _____ number _____

FIGURE 2

LANDING DATA SHEET
(full stop landings only)

DUTY RUNWAY _____ WIND _____ TIME _____

register/time

Side number _____ Aircraft type _____

Commence sequence 0/0
(enter break or 3 mi. on IFR approach)

Landing complete _____
(clear of runway)

Taxi complete _____
(pits/hot refuel holding area)

Fuel commence _____
(enter pits/hot refuel area)

Fuel complete _____
(depart pits/hot refuel area)

Shutdown _____

Parking area _____
(hot refuel aircraft only)

FIGURE 3

HOT REFUEL SEQUENCE DATA SHEET
(OCTAGON)

TIME _____

A/C Type (circle one)

Side number _____

Arrival time
at
holding area _____

Arrival time
into
octagon _____

Departure time
from
octagon _____

Pounds fuel
received _____

Fuel spilled yes/no

F-4
F-5
F-8
F-14
A-4
E-2
Transient

FIGURE 4

PIT REFUEL SEQUENCE DATA SHEET

TIME _____

A/C Type (circle one)

Side number _____

Arrival time
at
holding area _____

Arrival time
into
refuel pit _____

F-4
F-5
F-8
F-14
A-4
E-2
Transient

Shutdown

(circle one)

Pounds fuel
received _____

Fuel spilled yes/no

Hot refuel

Departure time
from
refuel pit _____

Pounds fuel
received _____

Fuel spilled yes/no

FIGURE 5

The aircraft/airbase operational data that were collected were used as input to the Source Inventory program. Air quality measurements (by NSI) and meteorological data (by PMTC) were also being collected during the entire period of observation.

IV. AQAM MODIFICATIONS AND SENSITIVITY STUDY

A. MODEL MODIFICATIONS

In order to perform a model validation, the data input to the Source Inventory program must reflect, as closely as possible, conditions and emittant sources as they exist at the time of validation. Therefore, one of the purposes of this study was to update the data in AQAM to represent 1978/1979 operations at NAS Miramar.

Changes made to the input routines of the AQAM program included data input on the E-2 aircraft -- an addition at NAS Miramar since 1975. Parking area coordinates, taxiway usage and aircraft landing and take-off operational cycle time-in-mode (LTO) were all modified to accept E-2 aircraft activity. All data were input in accordance with guidelines stipulated in Refs. 7 - 9 and 12. Averaged meteorological data were changed to reflect 1978 figures. The annual amount of aircraft activity for 1978, including arrivals, departures, touch-and-go cycles, and FCLP's was entered according to aircraft type. The specific parking areas and taxiways used by each aircraft were modified. Other emissions information

(specifically; fuel spillage, training fires, environ land use area factors, and off base vehicle miles per year) was either added or updated. Airbase, non-aircraft activity modifications included changes in test cell and run-up stand usage.

B. SENSITIVITY STUDY PARAMETERS AND PREDICTIONS

With the update completed and reflecting conditions as they existed at the time of the first intensive study, an investigation was performed to determine the sensitivity of the model predictions to meteorological and operational conditions anticipated for 1-7 August 1979 (special study). Sensitivity results indicate under what conditions and at what receptor locations the model can best be validated. In addition, these results are needed before conclusions can be drawn from the comparison of measured and predicted pollution levels. In a model validation effort, predicted concentrations are compared to measured values at specific receptor locations. When making these comparisons it is necessary to know how sensitive the model predictions are to the uncertainties in the specified meteorological and operational input data. For example, stability category is normally specified as an integer value between one and six; if the hourly averaged value can only be specified as two or three, what effect would this variation have on the model predictions? In addition, it is necessary to know whether the monitoring stations are located in regions where there are large horizontal gradients in pollution concentrations.

Twelve special receptors were used to examine the sensitivity of predicted pollution levels in the vicinity of the four monitoring stations to various meteorological conditions and model parameters. A previous model sensitivity study had been conducted by Netzer (Ref. 9) using 1975 operational data and different nominal meteorological conditions. Table III describes the special receptor locations used in AQAM for both the sensitivity study and the validation effort. Locations relative to runways, taxiways and refueling areas are depicted in Figure 1.

TABLE III
SPECIAL RECEPTOR LOCATIONS

AQAM RECEPTOR NUMBER	DESCRIPTION/LOCATION
401	trailer 1
402	trailer 2
403	100 m downwind of trailer 2
404	100 m crosswind (south) of trailer 2
405	100 m crosswind (south-east) of trailer 2
406	trailer 3
407	100 m downwind of trailer 3
408	100 m crosswind (south) of trailer 3
409	approach end of runway 1
410	trailer 4
411	500 m upwind of trailer 4
412	100 m crosswind (north) of trailer 4

20

In order to perform the sensitivity study it was necessary to establish a reference or nominal case meteorologically and operationally. The anticipated weather conditions for the intensive study period, listed in Section III, were used as the reference weather. Meteorological parameters were varied independently, with aircraft activity kept constant. Table IV indicates the meteorology data input for each of nine computer runs.

TABLE IV
METEOROLOGY FOR SENSITIVITY STUDY

Run Number	Turner Stability	Wind Speed (m/s)	Wind Direction (deg)	Temperature (°F)	Lid Height (m)
1 (Reference)	2	4.12	290	80	400
2	1	4.12	290	80	400
3	3	4.12	290	80	400
4	2	4.12	290	80	300
5	2	4.12	290	80	500
6	2	2.06	290	80	400
7	2	6.18	290	80	400
8	2	4.12	270	80	400
9	2	4.12	310	80	400

Run number 1 was the reference case. The ambient air temperature was not varied because previous results (Ref. 9) had shown it to have little effect on predicted pollution levels.

The aircraft activity data input to the Source Inventory program were representative of one hour of daytime flight operations. In addition, airbase and environ sources were kept constant with updated 1978 data. In the normal mode of utilization of AQAM, annual totals are input and frequency factors are used to determine the total operations in any one month, week, day, and hour. For the present effort, the "desired" one hour input data had to be scaled up to annual operations in order that the Short Term and Source Inventory programs would function properly. The "scale-up" factor used was:

$$12 \text{ hr/day} \times 31 \text{ day/mo (Aug)} \times 12 \text{ mo/yr} = \underline{\underline{4464}} \text{ hr/yr (1)}$$

(12 hr/day represents no night operations)

Table V presents the aircraft activity values which were held constant for the entire sensitivity study.

TABLE V
AIRCRAFT ACTIVITY FOR SENSITIVITY STUDY

1 HOUR OPERATIONS					
AIRCRAFT	ARRIVALS	DEPARTURES	TOUCH & GO'S	VFR ARRIVALS	FCLP'S
F-4	3	3	2	2	6
F-8	1	1	1	1	0
E-2	1	1	1	1	0
F-14	3	3	2	2	6
A-4	2	2	1	1	0
F-5	1	1	0	1	0
TRANSIENT	1	1	0	0	0
H-3	0	0	0	0	0

1 YEAR OPERATIONS					
AIRCRAFT	ARRIVALS	DEPARTURES	TOUCH & GO'S	VFR ARRIVALS	FCLP'S
F-4	13392	13392	8928	8928	267
F-8	4464	4464	4464	4464	0
E-2	4464	4464	4464	4464	0
F-14	13392	13392	8928	8928	267
A-4	8928	8928	4464	4464	0
F-5	4464	4464	0	4464	0
TRANSIENT	4464	4464	0	0	0
H-3	0	0	0	0	0

As explained in Section I, the results from the Source Inventory program are used along with the meteorological data as input to the Short Term program. Output from the Short Term program was arranged in seven tables. Four tables consisted

of pollutant levels in micrograms per cubic meter from environ, airbase, aircraft and total sources at all specified grid receptors. Each table listed, for all receptors, the receptor number and x-y coordinate location, and the concentrations for all five pollutants. The remaining three tables expressed the same results in terms of fractions of the total emissions from environ, airbase and aircraft sources.

The receptors of interest in the sensitivity study were the twelve special receptors (401-412) and that one where the maximum concentrations existed.

To compare the expected effects of the meteorological variables on the predicted ground level ($z=0$) concentrations, the Gaussian dispersion formula for point sources can be used (Ref. 13).

$$\chi(x,y,z=0;H) = \frac{Q}{\pi\sigma_y\sigma_z\bar{U}} \exp\left[-\frac{1}{2}\left(\frac{y}{\sigma_y}\right)^2\right] \exp\left[-\frac{1}{2}\left(\frac{H}{\sigma_z}\right)^2\right] \quad (2)$$

where:

χ = concentration, g/m^3

Q = uniform emission rate, g/sec

σ_y, σ_z = standard deviations of plume concentrations in the horizontal and vertical directions respectively, m

\bar{U} = mean wind speed, m/sec

H = initial plume height, m

$y = 0$ along plume centerline

When vertical diffusion is limited by a stable layer at height h_{lid} the diffusion equation is modified as follows:

$$\chi(x,y,z;H) = \frac{q}{\sqrt{2\pi} \sigma_y h_{lid} \bar{U}} \exp \left[-\frac{1}{2} \left(\frac{y}{\sigma_y} \right)^2 \right] \quad (3)$$

For infinite line sources Turner (Ref. 13) utilized:

$$\chi(x,y,z=0;H) = \frac{2q}{\sin \phi \sqrt{2w} \bar{U}} \exp \left[-\frac{1}{2} \left(\frac{H}{\sigma_z} \right)^2 \right] \quad (4)$$

where:

q = source strength per unit distance, g/sec-m

ϕ = angle between line source and wind direction,
 $45^\circ < \phi < 90^\circ$

Major variations of the Short Term program predictions under different meteorological conditions should follow equations (2), (3), or (4), depending upon the receptor location relative to the dominant emission sources (Ref. 9).

C. EFFECT OF METEOROLOGICAL PARAMETERS ON MAXIMUM RECEPTOR CONCENTRATIONS

Table VI presents the predicted maximum concentrations of four of the five pollutants and the location of each for the reference case. Also shown are the maximum predicted CO and PT from aircraft sources for each of the other conditions investigated. The meteorological variable is listed in each case.

The reference case indicated that the maximum contributions from the environ sources occurred south of the airbase (at receptors (9,2) and (11,2)). However, high levels of environ pollution (background) also were predicted to occur throughout

TABLE VI
 MAXIMUM RECEPTOR CONCENTRATIONS
 (GRID LOCATION, CONCENTRATION ($\mu\text{g}/\text{m}^3$), FRACTION OF TOTAL)

RUN NUMBER	AIRCRAFT			AIRBASE			ENVIRON					
	CO	HC	NOX	PT	CO	HC	NOX	PT	CO	HC	NOX	PT
1 REFERENCE CASE	11,8	11,8	11,8	11,8	14,8	14,8	14,8	14,8	9,2	11,2	11,2	11,2
	101	31	14	139	5	2	3	4	313	110	29	22
	.61	.74	.74	.98	.04	.05	.22	.11	1.0	1.0	1.0	1.0

1 REFERENCE CASE	TOTAL		
	CO	HC	NOX
	9,2	11,2	11,2
	313	110	29
			141

RUN NUMBER	AIRCRAFT	
	CO	PT
2 STAB CAT = 1	11,8	11,8
	60	61
	.50	.97
3 STAB CAT = 3	13,8	11,8
	194	255
	.69	.99
4 LID HT = 300m	11,8	11,8
	103	150
	.59	.99
5 LID HT = 500m	11,8	11,8
	101	139
	.66	.99

RUN NUMBER	AIRCRAFT	
	CO	PT
6 WIND SPD = 2.06 m/sec	11,8	11,8
	272	321
	.68	.99
7 WIND SPD = 6.18 m/sec	11,8	11,8
	71	94
	.63	.99
8 WIND DIR = 270°	10,8	10,8
	131	121
	.61	.98
9 WIND DIR = 310°	11,8	11,8
	96	106
	.66	.98

the airbase. On the airbase, the contribution from airbase sources was generally negligible, whereas aircraft sources of PT were dominant. Maximum concentrations from aircraft sources occurred for CO and PT at receptor (11,8), near the intersection of the runways. This was generally the case for all the conditions investigated.

1. Stability Category

Increasing the stability category (more stable conditions) decreases σ_y and σ_z , and therefore should increase the predicted ground level concentration along the wind vector downwind of the source (see equation (2)). At the peak concentration receptors (Table VI), which are necessarily near the plume centerline, the increase in stability category increased the concentration and shifted the maximum concentration receptor downwind.

2. Lid Height

As a plume develops downwind of a source it will spread in a vertical, as well as horizontal, direction. The ground and lid height (elevated inversion layer) act as reflectors of the plume. Increasing the lid height would decrease the concentration only at receptors which are far enough downwind from the source for reflections to occur (see equation (3)). For the maximum receptor location (11,8), lid height had negligible effect on the predicted concentrations (Table VI) since it was located near the major aircraft sources.

3. Wind Speed

Increasing the wind speed should decrease predicted concentrations along the plume centerline for a single source (equations (2), (3) and (4)). This behavior was apparent for the maximum concentration receptors (Table VI, run nos. 6, 1 and 7).

4. Wind Direction

Changing wind direction changes the orientation of the plume dispersion. As a result, the receptor where concentrations were a maximum from aircraft sources was predicted to shift to receptor (10,8) when the wind direction became 270° (Table VI, run no. 8).

D. EFFECT OF METEOROLOGICAL PARAMETERS ON CONCENTRATIONS AT SPECIAL RECEPTORS

Short Term output for each of the nine sensitivity runs is presented in Appendix A for the special receptors. The reference case (run no. 1) output includes receptor concentrations for environ, airbase, aircraft, and total sources in $\mu\text{gm}/\text{m}^3$ as well as fractional values for aircraft sources. Receptor concentrations for aircraft sources (run nos. 2-9) are included in $\mu\text{gm}/\text{m}^3$ and fraction of total. In order to visualize variations in pollutant concentration, the overall grid system was mapped with contour levels for the sensitivity study in Appendix B. Contours for the reference case are included for CO and PT concentrations from airbase, aircraft, and total sources. Contours for run nos. 2-9 are included for CO and PT concentrations from aircraft sources.

Tables VIIa-d summarize the special receptor concentrations of CO and PT for each of the nine sensitivity runs. In general, the comments relating to the maximum receptor concentrations pertain to the special receptor concentrations. From a modeling standpoint special receptor 401 (trailer 1) proved to be well located for the purpose of measuring background pollutants. As can be seen in Tables VIIa-d, very little CO and PT due to aircraft exist at receptor 401. When finite values did occur (run nos. 2, 3, 7, 8 and 9) they resulted from the aforementioned method of projecting area sources (in this case -- the hot refueling area) upwind to pseudc-point sources.

1. Stability Category

An increase in stability category increases the downwind concentration along the plume centerline from a single source since the plume spreads more slowly. Table VIIa indicates that the area around trailer 1 (receptors 402-405) receives emittants from multiple sources since the concentrations of CO and PT first decreased and then increased with increasing stability category. These receptors are also located very near large sources.

CO and PT concentrations around trailer 3 (receptors 406-408) were significantly higher than those around trailer 2 due to the effect of an increased number of plumes overlapping downwind. Some multiple/near source effects were also evident at this location. The receptor concentrations around trailer 4 (receptors 410-412) changed only slightly with variations

TABLE VIIa
SPECIAL RECEPTOR CONCENTRATIONS
(STABILITY CATEGORY VARIATION)

RUN NUMBER	AIRCRAFT EMITTER	401 TRAILER 1	402 TRAILER 2	403 100m DOWNWIND	404 100m CROSSWIND	405 100m DOWN AND CROSS	406 TRAILER 3	407 100m DOWNWIND	408 100m CROSSWIND	410 TRAILER 4	411 500m UPWIND	413 100m CROSSWIND	409 APPROACH END OF RW
2 STAB CAT - 1	CO	3	55	84	85	62	121	288	270	21	21	24	927
	PT	20	53	54	123	65	77	204	286	23	25	25	572
1 REFERENCE	CO	0	3	30	49	45	98	314	225	22	25	28	3575
	PT	0	13	25	106	178	78	331	241	26	30	29	2706
3 STAB CAT - 3	CO	5	98	141	141	119	246	444	366	38	53	43	1074
	PT	28	195	174	325	228	162	424	306	50	68	52	660
		.93	.99	.98	.99	.99	.98	.99	.99	.98	.97	.96	.99

Concentration, $\mu\text{g}/\text{m}^3$
Fraction of Total
KEY = Concentration, $\mu\text{g}/\text{m}^3$
Fraction of Total

TABLE VIb
SPECIAL RECEPTOR CONCENTRATIONS
(LID HEIGHT VARIATION)

RUN NUMBER	AIRCRAFT EMISSION	401 TRAILER 1	402 TRAILER 2	403 100m DOWNWIND	404 100m CROSSWIND	405 100m DOWN AND CROSS	406 TRAILER 3	407 100m DOWNWIND	408 100m CROSSWIND	410 TRAILER 4	411 500m UPWIND	412 100m CROSSWIND	409 APPROACH END OF RW 3575
4	CO	0	3	30	49	45	95	320	221	29	30	32	3575
	PT	0	13	25	106	178	78	331	240	34	38	37	2710
	LID HT = 300 m	0	0	.93	.41	.99	.97	.79	.99	.93	.94	.94	.98
1	CO	0	3	30	49	45	98	314	225	22	25	26	3575
	PT	0	13	25	106	178	78	331	241	26	30	29	2706
	REFERENCE	0	0	.93	.44	.99	.97	.83	.99	.77	.93	.94	.98
5	CO	0	3	30	49	45	98	314	225	19	23	23	3575
	PT	0	13	25	106	178	78	331	240	22	28	25	2706
	LID HT = 500 m	0	0	.94	.47	.99	.98	.85	.99	.94	.95	.95	1.0

Concentration, $\mu\text{g}/\text{m}^3$
Fraction of Total

KEY = Concentration, $\mu\text{g}/\text{m}^3$
Fraction of Total

TABLE VIIIC
SPECIAL RECEPTOR CONCENTRATIONS
(WIND SPEED VARIATION)

RUN NUMBER	AIRCRAFT EMISSION	401 TRAILER 1	402 TRAILER 2	403 100m DOWNWIND	404 100m CROSSWIND	405 100m DOWN AND CROSS	406 TRAILER 3	407 100m DOWNWIND	408 100m CROSSWIND	410 TRAILER 4	411 500m UPWIND	12 100m CROSSWIND	409 APPROACH END OF RW 2151
6	CO	0	88	110	147	170	240	891	675	46	49	55	2151
	PT	0	.40	.46	.53	.57	.63	.87	.83	.27	.29	.31	.94
		0	.98	.97	.99	.98	.97	1.0	.99	.93	.94	.94	1.0
1	CO	0	3	30	49	45	98	314	225	22	25	26	3575
	PT	0	.05	.32	.44	.41	.59	.83	.77	.27	.30	.30	.98
		0	.93	.94	.98	.97	.98	.99	.99	.92	.94	.93	1.0
7	CO	2	42	52	76	44	78	204	153	15	17	17	623
	PT	12	.50	.54	.64	.51	.63	.83	.77	.21	.30	.23	.94
		.91	.93	.94	.98	.97	.98	.99	.99	.92	.94	.93	1.0

KEY = Concentration, $\mu\text{g}/\text{m}^3$
Fraction of Total
Concentration, $\mu\text{g}/\text{m}^3$
Fraction of Total

TABLE VIId
SPECIAL RECEPTOR CONCENTRATIONS
(WIND DIRECTION VARIATION)

WIN NUMBER	AIRCRAFT EMITTANT	401 TRAILER 1	402 TRAILER 2	403 100m DOWNWIND	404 100m CROSSWIND	405 100m DOWN AND CROSS	406 TRAILER 3	407 100m DOWNWIND	408 100m CROSSWIND	410 TRAILER 4	411 500m UPWIND	412 100m CROSSWIND	409 APPROACH END OF RW
8 WIND DIR = 270°	CO	0	27	22	125	72	152	536	226	7	10	9	973
	PT	0	143	52	367	.46	135	610	.73	9	12	11	517
1 REFERENCE	CO	0	3	30	49	.98	98	314	.99	22	25	26	3575
	PT	0	13	25	106	.41	78	331	.77	26	30	29	2706
9 WIND DIR = 310°	CO	3	2	5	14	.99	4	71	.99	41	34	48	1682
	PT	18	1	4	30	.53	5	38	.49	34	29	39	1192
		.83	.44	.74	.86	.98	.76	.95	.95	.93	.94	.93	1.0

Key =
Concentration, $\mu\text{g}/\text{m}^3$ Fraction of Total
Concentration, $\mu\text{g}/\text{m}^3$ Fraction of Total

in meteorological conditions due to the large downwind distance from the primary sources. Concentrations at receptor 409 were high as expected due to its close proximity to runway and taxiway line sources.

2. Lid Height

At trailers 2 and 3 lid height had no effect (Table VIIb). This was expected since these locations are very near the sources of pollution. At trailer 4, which is far downwind, increasing lid height decreased concentrations.

3. Wind Speed

As indicated in Table VIIc, an increase in wind speed decreased the concentration downwind at trailers 3 and 4. Again, however, at trailer 2 the behavior was more random.

4. Wind Direction

Changing the wind direction from the reference 290° to 310° (run no. 9) resulted in the expected reduction in aircraft CO and PT at trailers 2 and 3 (Table VIId). In this case the plumes from the major upwind aircraft sources miss receptors 402 and 406. However, when the wind direction was changed to 270° (run no. 8), the concentrations increased significantly. This indicates that trailer 2 was apparently outside the plume from the hot refueling area when the wind was from 290° . Further evidence of this was that receptors 404 and 405 (crosswind to 402) had significantly higher concentrations than receptors 402 and 403.

The trailer 4 receptor exhibited an increase in concentration with an increase in wind direction. This was expected

since most aircraft source plumes (including the maximum receptor location at coordinate (11,8) are located upwind of trailer 4, from the 290^o-310^o direction.

5. Special Receptor Locations

As discussed above, for model validation efforts it is necessary to know whether the monitoring stations are located in regions where there are large horizontal gradients in pollution concentration or where the concentrations are very sensitive to the specified hourly-averaged meteorological conditions. Table VIII presents a summary of the effects of distance from the monitoring stations on the predicted pollution concentrations. Concentrations are presented for each of the nine cases for conditions 100m downwind and 100m crosswind. As a receptor is moved toward a specific plume centerline, the concentration would increase. When a receptor is located downwind from several sources, horizontal movement of the receptor may increase or decrease the receptor pollution level, depending on the multiple plume effects.

Increases in concentration varied by factors of two to sixteen at trailers 2 and 3 for the reference case as a result of moving the receptor 100m downwind or closer to plume centerline. No appreciable horizontal gradients in concentration existed around trailer 4. In almost every case (variation of meteorological parameters), concentrations increased as expected, since the receptors were moved closer to the centerlines of the major aircraft-related plumes for the 290^o wind. In run no. 8,

TABLE VIII
DIFFERENCE FACTORS IN SPECIAL RECEPTOR CONCENTRATIONS

RUN NO.		<u>Trailer 2</u>		<u>Trailer 3</u>		<u>Trailer 4</u>
		100m down-wind 403/402	100m cross-wind 404/402	100m down-wind 407/406	100m cross-wind 408/406	
1 Reference	CO	inc 10	inc 16	inc 3	inc 2.3	No change
	PT	inc 2	inc 8	inc 4.3	inc 3	
2 Stability Category	CO	inc 1.5	inc 1.5	inc 2.5	inc 2.3	No change
	PT	no change	inc 2.5	inc 3.8	inc 3.8	
3	CO	inc 1.5	inc 1.5	inc 1.8	inc 1.5	
	PT	dec 1.1	inc 1.7	inc 2.5	inc 2.3	
4 Lid Height	CO	inc 10	inc 16	inc 3	inc 2.3	No change
	PT	inc 2	inc 8	inc 4.3	inc 3	
5	CO	inc 10	inc 16	inc 3	inc 2.3	
	PT	inc 2	inc 8	inc 4.3	inc 3	
6 Wind Speed	CO	inc 1.3	inc 1.7	inc 3.8	inc 2.8	No change
	PT	dec 1.5	inc 1.8	inc 5	inc 4	
7	CO	inc 1.3	inc 1.8	inc 2.5	inc 2	
	PT	inc 1.5	inc 4.5	inc 3.8	inc 2.8	
8 Wind Direction	CO	dec 1.3	inc 5	inc 3.5	inc 1.5	No change
	PT	dec 2.8	inc 2.5	inc 4.5	inc 2	
9	CO	inc 2.5	inc 7	inc 18	inc 13	
	PT	inc 4	inc 30	inc 7.5	inc 6	

where the wind direction was changed from 290° to 270° , the concentration at the 100m downwind location decreased at trailer 2.

These results again indicate that comparison between measurements and predictions will be most difficult at trailer 2. Not only do multiple plume effects and the close proximity to ground aircraft sources cause unusual variations in concentration with changing meteorology but also the horizontal gradients are quite large.

E. EFFECT OF SPECIFIED AREA SOURCE SIZE ON RECEPTOR CONCENTRATIONS

When large sources are input into AQAM they are normally modeled as area sources. The dimensions of the area sources have to be specified and some judgement is required to pick the most representative dimensions of these "uniform concentration sources." To determine what effect the specified size of aircraft area sources had on concentrations at various receptors, the lengths of the sides of three prime sources were both increased and decreased by forty percent. The specific sources included the hot refueling area, the hot refueling delay area and the pit refueling delay area. The length of the sides of each area source in the reference case was 500 meters. This length was changed to 300 meters and then to 700 meters.

Increasing the size of an area source effectively moves the pseudo-upwind point source further upwind. Keeping the

emittants and meteorology constant, the plume would spread at the same rate. At a specific receptor, the concentration can increase or decrease, depending on its location relative to the area sources. For this study, the variations in concentrations at trailers 2, 3, and 4 never exceeded six percent.

F. VARIATION OF JET PENETRATION LENGTH AND HORIZONTAL AND VERTICAL DISPERSION PARAMETERS

In AQAM, turbojet exhausts during taxi and takeoff are treated as finite line sources. Initial line source dimensions and locations have to be specified and these are somewhat arbitrary. Currently in AQAM the jet is assumed to "penetrate 140 meters" (i.e., approximately 140 jet diameters) before coming to rest relative to the ambient air. Default values for the line source cross-sectional size are 5m high by 20m wide. No plume rise is considered to occur. These line sources are then treated as pseudo-upwind lines which disperse in a Gaussian manner with the same empirical dispersion parameters (σ_y, σ_z) as used for elevated point sources.

In a recent study at the Naval Postgraduate School (Ref. 14) jet characteristics were measured in a simulated, neutrally stable atmosphere. It was found that jet penetration length was considerably less than 140 jet diameters; being more nearly 35 jet diameters. Initial plume dimensions were found to vary significantly with jet orientation to the ambient wind direction and some plume rise was observed. Jet dispersion rates were also found to spread more rapidly than currently used in AQAM.

In order to determine whether the above findings would have any significant effects on the predicted concentrations from aircraft sources, AQAM was modified in sequential steps as follows:

- (1) decrease the jet penetration length from 140 to 35 meters.
- (2) step (1) and specification of initial aircraft line source (taxiway and runway) dimensions as a function of orientation to the wind (per fig. 40, Ref. 14).
- (3) steps (1) and (2) and decrease the stability category by one to increase the jet plume spreading rate.

Decreasing the penetration length was found to have little effect. This was somewhat expected since the aircraft line sources at NAS Miramar vary in lengths of up to 3.7 km. The reduction in jet penetration length was but three percent of the longest line source. In step (2) the angle of incidence formed by the wind with each line source was determined, and using the σ_y and σ_z versus angle of incidence relationship determined by Brendmoen and Netzer, new horizontal and vertical dispersion parameters were input to the Short Term program. In general, the changes involved increases in initial line source dimensions. At the maximum concentration receptor and at trailers 3 and 4, a nominal reduction in concentrations of up to a maximum of 16 percent was predicted.

In step (3) the above changes were kept in AQAM and the stability category was decreased from 3 to 2 (more unstable conditions). Output indicated a decrease in concentration of up to a factor of two at the maximum concentration receptor and at trailers 3 and 4. It should be noted that in its present form AQAM only allows variation of stability category for all dispersions as opposed to variation of aircraft sources alone. This decrease was expected as previously determined in the meteorological sensitivity study.

G. CONCLUSIONS

Stability category and wind speed were the two meteorological parameters that most affected maximum receptor concentrations. Model predictions will therefore be most sensitive to uncertainties in the hourly-averaged values of these parameters which are input into AQAM. Wind direction had a large effect on the concentrations at trailer 2. Trailer 2 is apparently located in an area where large horizontal gradients of pollutant concentrations exist, i.e., near the edges of the plume from large aircraft sources.

Trailer 1 appears to be a good location for measurement of background pollution levels.

Variations in aircraft area source sizes did not appreciably affect concentration levels at specific receptors.

Variations of the specified jet penetration length and initial horizontal and vertical dispersion parameters of aircraft exhaust plumes during taxi, takeoff and landing modes

changed concentrations by a maximum of only 16 percent. The data of Brendmoen and Netzer (Ref. 14) indicated that turbo-jet exhausts spread more rapidly than elevated point sources. This result, when incorporated into AQAM, significantly affected predicted concentration levels (by a factor of 2) at the monitoring trailer locations.

V. COMPARISON OF AQAM PREDICTIONS
WITH
DATA FROM THE INTENSIVE STUDY

A. VALIDATION REQUIREMENTS

As previously stated, model validation consists of comparing predicted hourly-averaged pollutant concentrations to hourly-averaged measured values at specific receptor locations. A determination of model accuracy must be made within the context of the accuracy of the input operational data and of the hourly-averaged meteorology and measured concentrations. It is important to note that although the meteorology and pollutant concentrations may be constantly varying, only hourly-averaged values are used. Comparisons between measured and predicted concentration values in areas where large horizontal gradients exist (trailer 2) are likely to exhibit widely-varying results. Because of these factors, a need exists for a vast amount of accurate data with which to conduct model validation.

Prior to the comparison of measured and predicted values, background levels/local air quality must be determined in order

to be able to separate the contributions of aircraft, airbase and environ sources throughout the receptor grid. The Source Inventory program allows for input of environ sources. If these data are not available, approximate inputs can be included through the use of land-use factors. The factors (Ref. 12) distinguish between city center, urban, rural, park areas, etc. Input for off-base line sources (roadways) requires appropriate vehicle mileage and speed values. The selection of appropriate land-use factors used in this study was somewhat judgemental. The roadway line source values used were based on actual average daily traffic volumes for 1978 as provided by the Comprehensive Planning Organization of the San Diego Region. One method for determining actual concentrations from aircraft/airbase sources is to subtract values from an upwind measurement (i.e., trailer 1 data) from values obtained at each of the other special receptors.

Comparison of weekend measured data at each special receptor with weekday data should also provide a good indication of background/envIRON pollutant levels due to the reduction in aircraft activity at NAS Miramar on weekends. The measured data indicated a wind speed varying from calm to five knots on Saturday and Sunday approximately 90% of the time. The wind direction also varied up to 180° throughout the two-day period. This slight-to-stagnant air motion apparently caused an accumulation of pollutants at NAS Miramar from environ (local San Diego) sources. Unfortunately, this behavior

42
invalidated any comparison between weekday and weekend concentrations for the purposes of validating weekday background levels on the airbase. Therefore, a need exists for additional weekend data when the meteorological conditions are more representative of those experienced during the period of intensive measurement.

B. DATA REDUCTION AND MODEL INPUTS

Measured data for CO, NOX and THC were provided by NSI in parts per million (ppm). Comparison of these values to AQAM predictions requires conversion to micrograms per cubic meter ($\mu\text{gm}/\text{m}^3$). An accurate conversion exists for CO under standard conditions; $1111.11 \times \text{ppm CO} = \mu\text{gm}/\text{m}^3 \text{ CO}$. The most often used conversion for NOX is based upon NO_2 : $2000 \times \text{ppm NOX} = \mu\text{gm}/\text{m}^3 \text{ NOX}$. Measured data were obtained for THC and CH_4 . CH_4 usually contributes from 60-90 percent of THC concentration in urban atmospheres of North American latitudes. Typical concentrations are 1.25-1.5 ppm (Ref. 6). The CH_4 conversion is $666.67 \times \text{ppm CH}_4 = \mu\text{gm}/\text{m}^3 \text{ CH}_4$. The PT data were measured by a nephelometer in terms of the scattering coefficient, b (bscat). Air samples were also taken to determine total particulates, but the data were invalidated as a result of a filter preparation error by contractors at U. C. Davis. For the bscat data, an average conversion factor was employed (Ref. 15); $46.15 \times \text{Neph (bscat)} \approx \mu\text{gm}/\text{m}^3 \text{ PT}$.

The AQAM model was run over ten one-hour time periods as listed in Table IX. The type of aircraft activity varied

TABLE IX
 AQAM RUNS MADE FOR INTENSIVE STUDY

RUN NUMBER	DATE AND TIME PERIOD	WEATHER CONDITIONS						LID HEIGHT (M)	AIRCRAFT ACTIVITY REMARKS
		TURNER STABILITY CATEGORY	WIND SPEED (M/S)	WIND DIRECTION (DEG)	TEMP (°F)				
1	1 AUG 1300-1400	2	2.57	290	81		353	--	
2	1400-1500	2	2.57	290	81		353	--	
3	2 AUG 1400-1500	3	2.57	290	77		522	--	
4	1500-1600	3	2.57	270	77		517	HI T/O, HI LDG	
5	1515-1615	2	1.54	270	76		515	HI T/O, HI LDG	
6	3 AUG 1100-1200	1	2.57	230	77		586	--	
7	6 AUG 1400-1500	3	3.60	270	91		1287	LO T/O, LO LDG, LO FCLP	
8	1500-1600	3	3.09	270	90		1229	HI T/O, LOW LDG	
9	1515-1615	3	3.09	270	90		1229	HI T/O, NORMAL	
10	7 AUG 1500-1600	3	3.09	300	82		539	LO T/O, NORMAL LDG, ECLP	

considerably throughout the ten AQAM runs. When different from normal operations, remarks of the activity are included in Table IX. The chosen periods of time were primarily in the afternoon when the wind speed and lid height are greatest.

Figures 6a-e present the meteorological conditions at NAS Miramar (obtained from NAS, Pt. Mugu investigators) for the days of intensive measurements and detailed observation of aircraft activity. The values are hourly-averaged and plotted over the 1000-2000 time period for each day. All weather conditions were averaged over the applicable time periods shown cross-hatched in Figures 6a-e.

Runs 5 and 9 were performed to determine whether or not transit time of emittants affected predicted concentration levels relative to runs 4 and 8. A fifteen minute emittant travel time was chosen due to the wind speed and average distance from source to monitoring station. It should be noted that the final runs (6-7 August) had significantly higher wind speed, temperature and lid height. This variation in meteorology was not anticipated and was somewhat undesirable from a model validation viewpoint.

Due to variations in meteorology within the calculated dispersion times, it is generally agreed that the values of σ_y and σ_z cannot be more accurate than a factor of 2. In addition to this uncertainty, model predictions are sensitive to the average meteorology used as input as discussed above. For example, consider the data presented in Fig. 6a for the

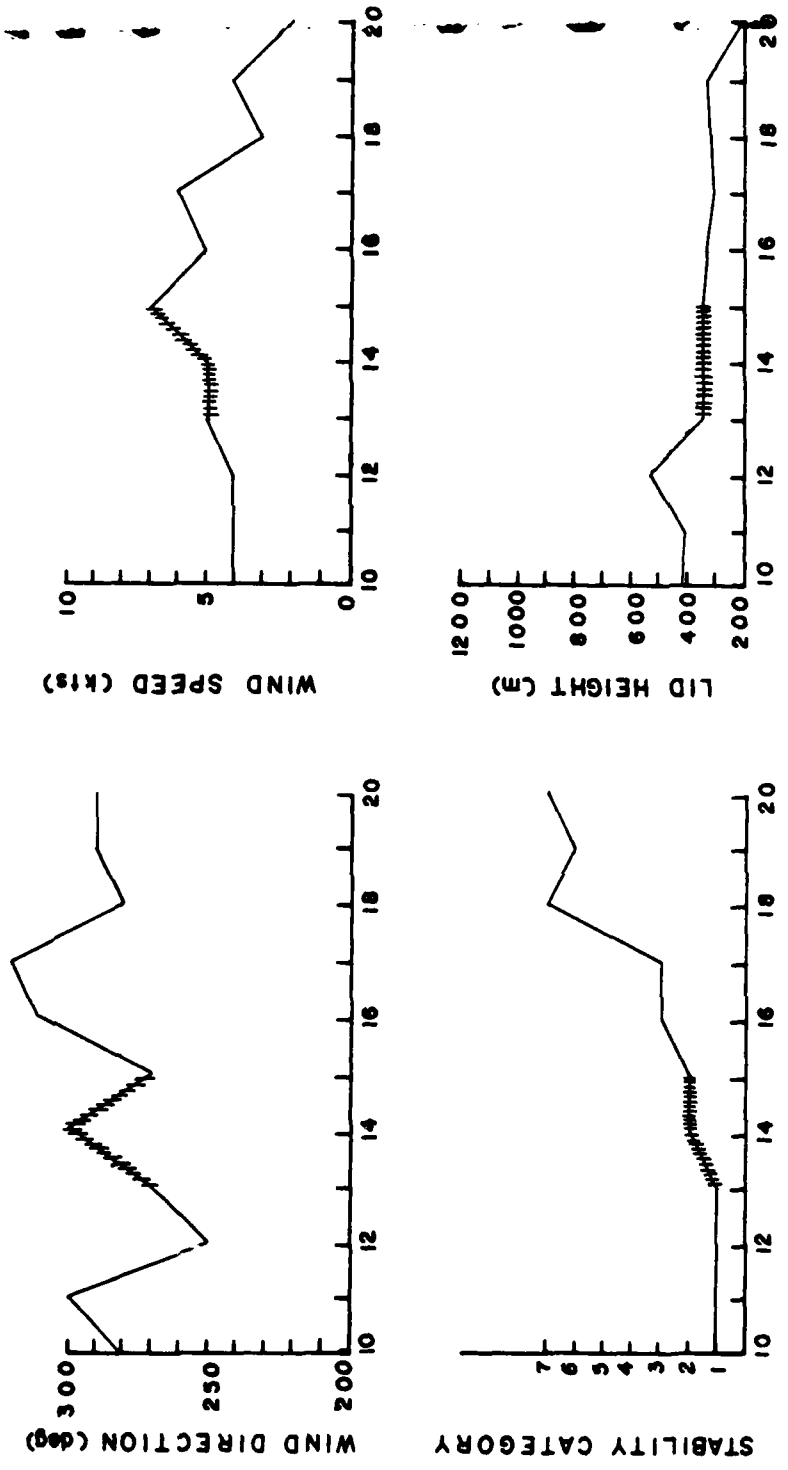

METEOROLOGICAL CONDITIONS AT NAS MIRAMAR VS. TIME OF DAY (1 AUG)

Figure 6a

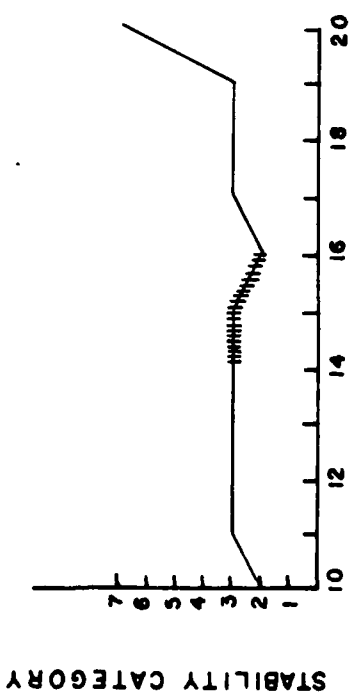
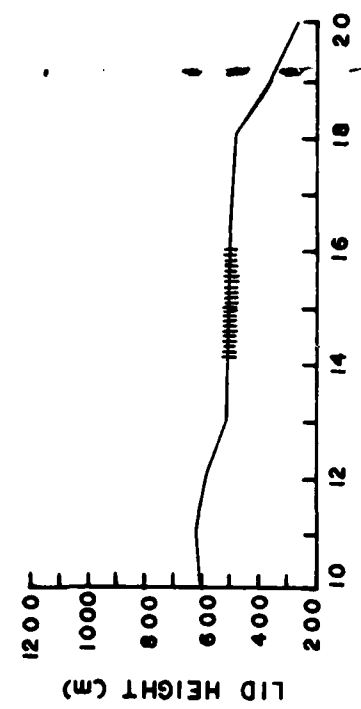
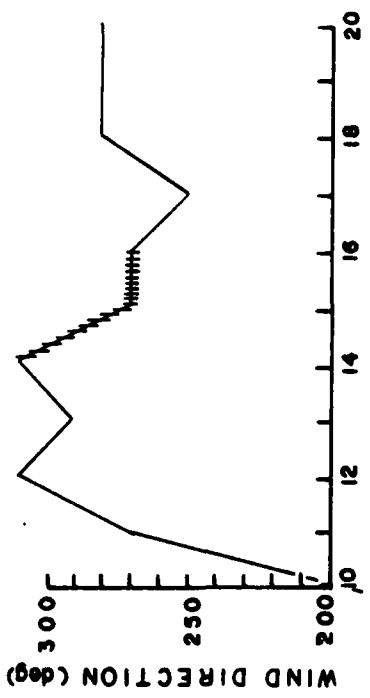
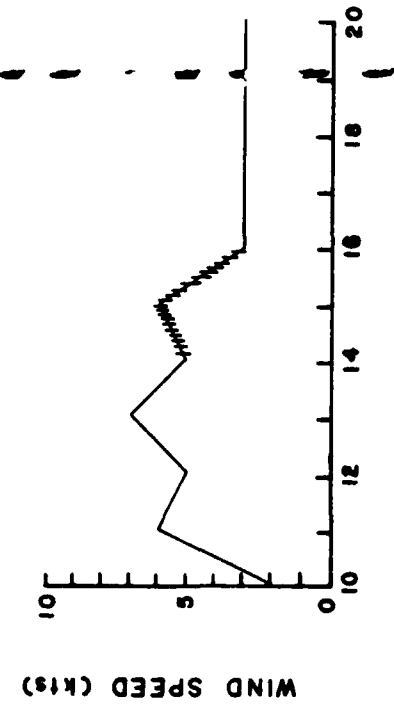

METEOROLOGICAL CONDITIONS AT NAS MIRAMAR VS. TIME OF DAY (2 AUG)

Figure 6b

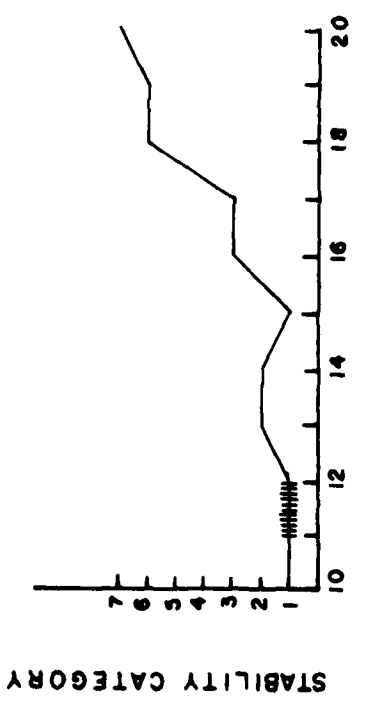
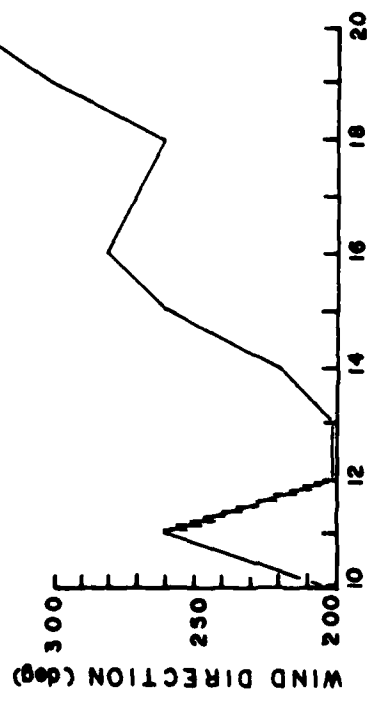
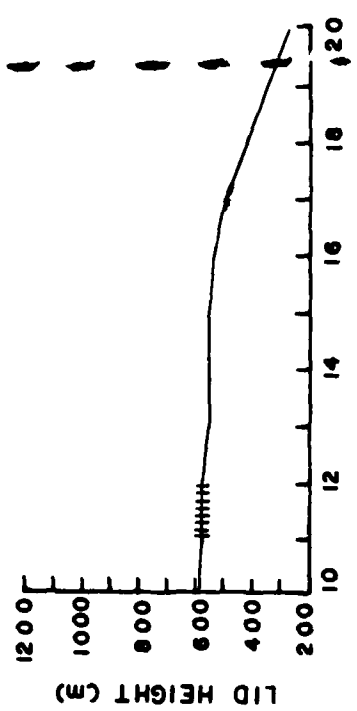
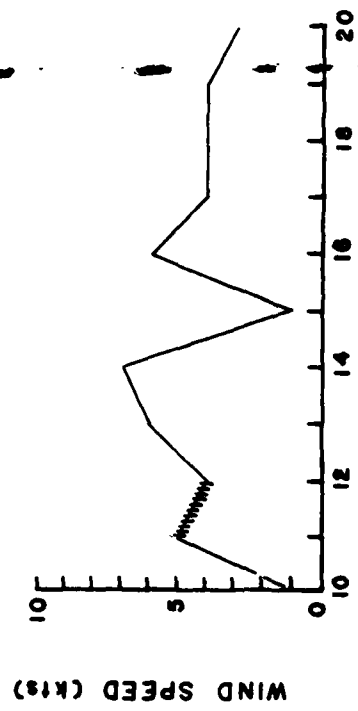

METEOROLOGICAL CONDITIONS AT NAS MIRAMAR VS. TIME OF DAY (3 AUG)

Figure 6c

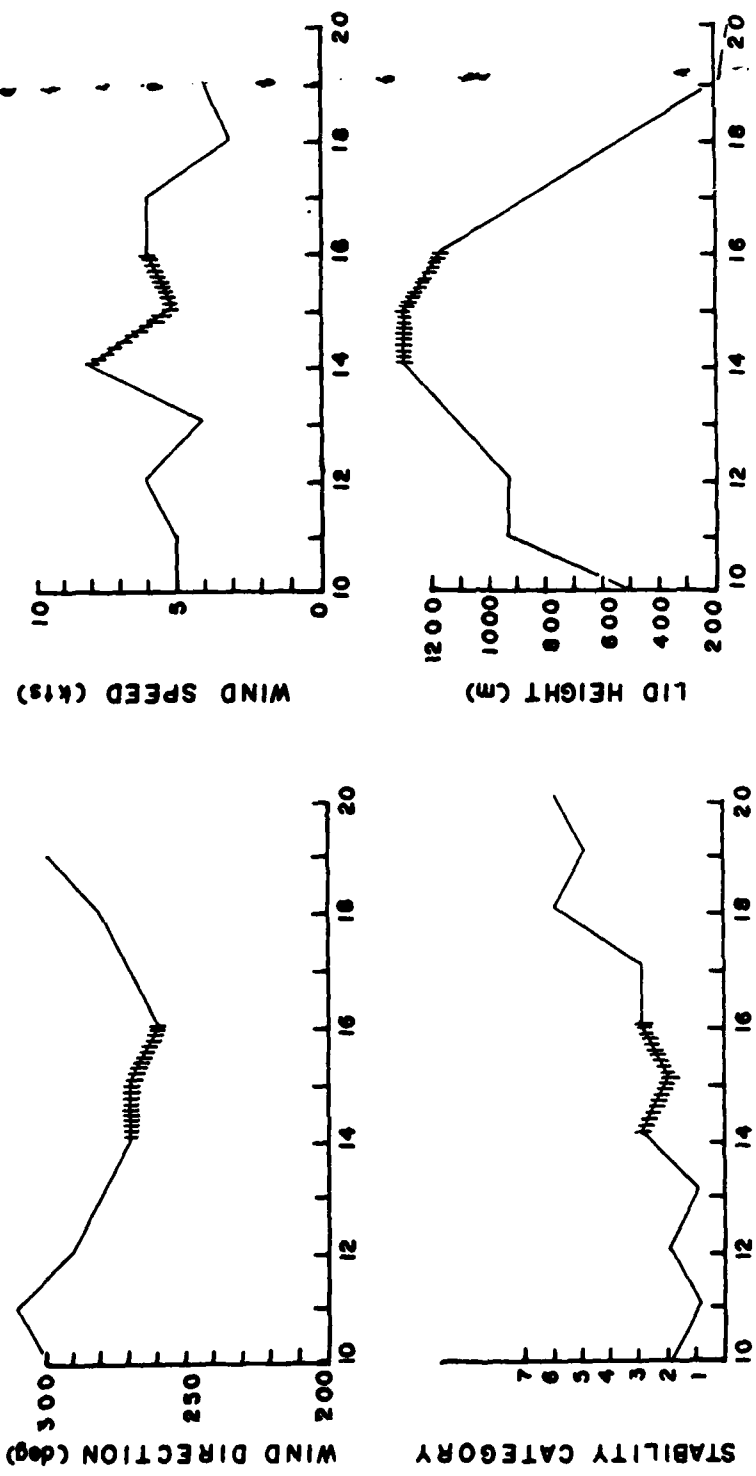

METEOROLOGICAL CONDITIONS AT NAS MIRAMAR VS. TIME OF DAY (6 AUG)

Figure 6d

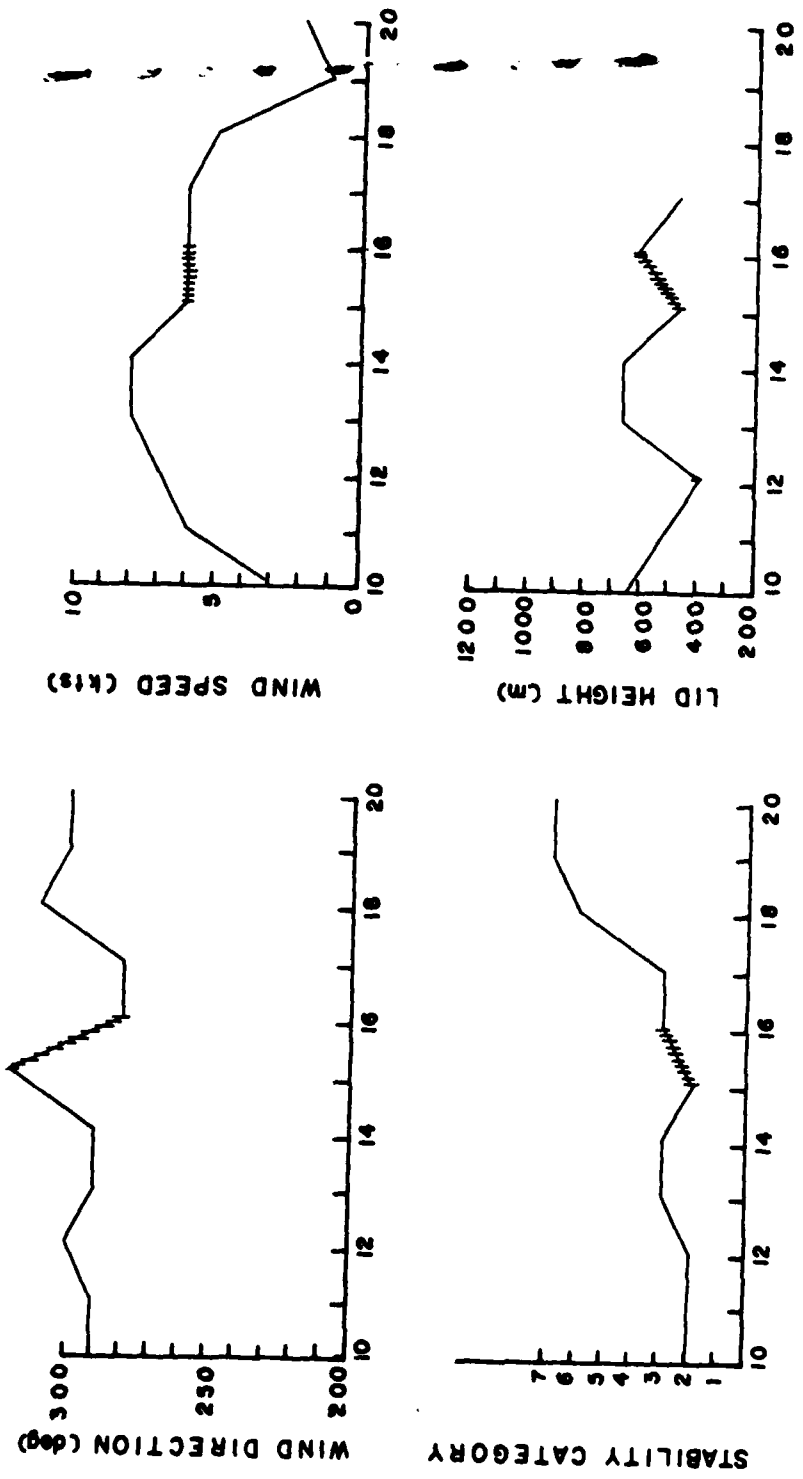

METEOROLOGICAL CONDITIONS AT NAS MIRAMAR VS. TIME OF DAY (7 AUG)

Figure 6e

period 1300-1400 hrs. During this period the wind direction changed from 270° to 300° and the stability category changed from 1 to 2. The lid height and wind speed were steady. Values employed for wind direction and stability category for this period (Table IX, run no. 1) were 290° and 2, respectively. The sensitivity study of section IV has shown that a decrease in wind direction of 20° and a decrease in stability category from 2 to 1 can increase the predicted concentrations at trailer 3 by factors of 1.5 and 1.3 respectively. Thus, measured data and predictions could be different by a factor of approximately 2 due to uncertainty in model meteorological input alone.

C. DISCUSSION OF RESULTS

This discussion is divided into four sections -- one for each of the pollutants measured. The included figures are scatter plots of measured CO, NOX, THC and nephelometer readings versus predicted concentrations. The diagonal lines drawn in these figures enclose predictions that are within a factor of two of the corresponding measurements. These lines were found to enclose greater than 50% of all the plotted points. Much of the measured data were invalidated by NSI and were therefore not available for plotting. This is the reason for the differences in numbers of plotted points from graph to graph.

Variations in predicted pollutant concentrations over the airbase were mapped with contour levels for the intensive study

5
and are presented in Appendix C. Contours for run no. 4 (2 Aug, 1500-1600) are included for CO and PT concentrations from airbase, aircraft and total sources. Contours for the other nine runs are included only for CO and PT concentrations from aircraft sources.

1. Carbon Monoxide (CO) Emissions

A comparison of the CO emitted each weekday with the CO emitted during the weekend (period of reduced aircraft activity) was performed to better determine the CO background level. It was found that on Saturday afternoon the level was higher than that on Monday by a factor of two, possibly due to heavy traffic conditions on the surrounding roadways. Also, on Sunday, when the winds were mostly calm or from the south, a high level of CO was measured at trailer 1. As previously stated, weather conditions for the weekend during the period of intensive measurement were not representative of weather conditions during the weekdays. Therefore, no conclusions could be drawn from this comparison regarding the validity of using trailer 1 measurements as indicators of background CO levels.

Figure 7 indicates that measured concentrations agreed with predicted total concentrations within a factor of two at trailers 1 and 4. The agreement was within a factor of approximately three for trailer 3 data. (No measured CO data for trailer 2 was available during the ten one-hour time periods used in this study.) However, the good agreement may

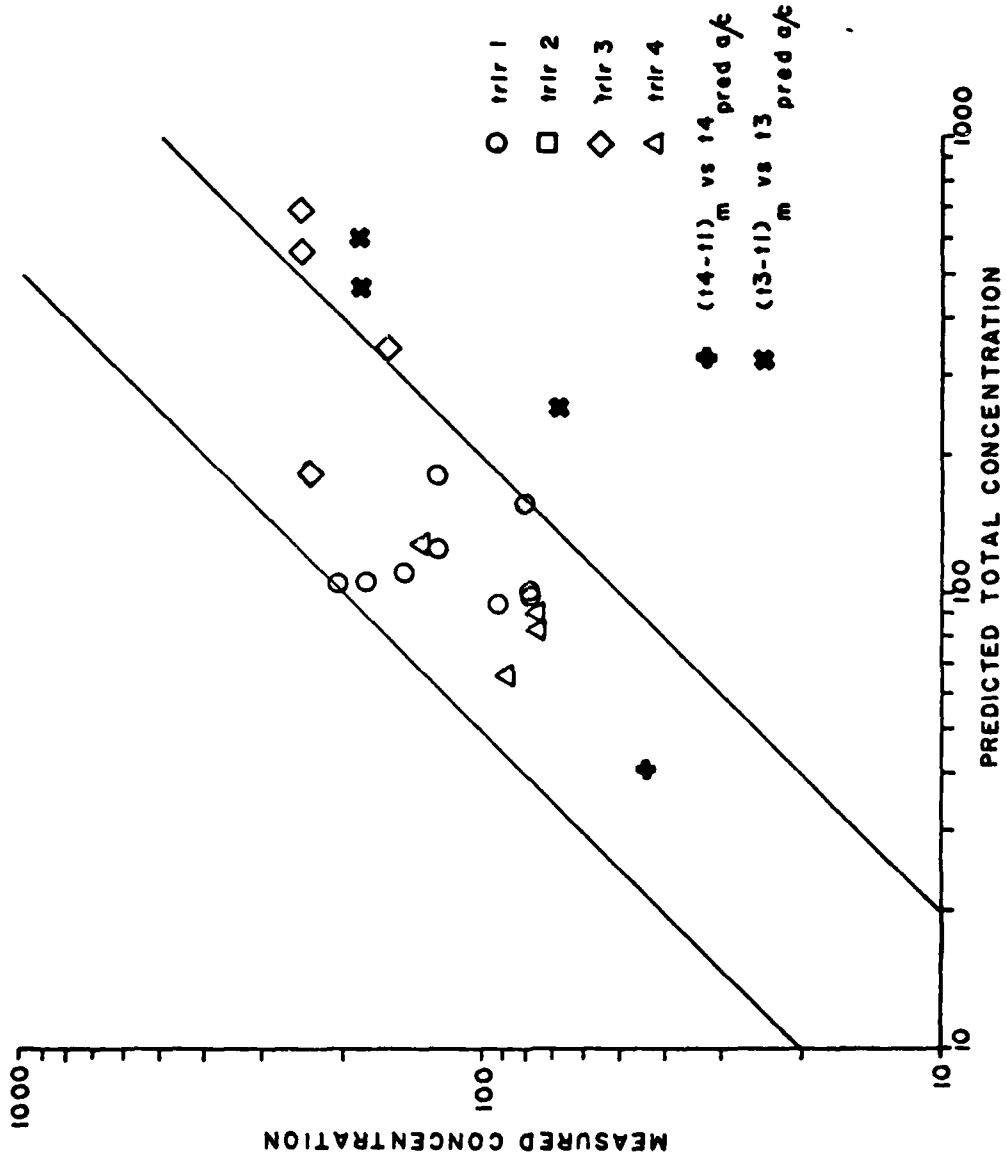

Measured vs. Predicted Hourly Average CO Concentrations for Intensive Study
 FIGURE 7

be chance since the environ input (land-use factors, vehicle mileage data, etc.) was only estimated. In other words, what if the high levels of CO concentration at trailer 1 were due to aircraft, but the model did not have properly input aircraft operations or did not correctly determine dispersion rates? AQAM predicted that the CO concentration due to aircraft at trailer 1 was essentially zero. To check this, the Source Inventory program was modified so that all aircraft climb angles on takeoff were decreased. This maximized the near ground emissions from aircraft in the area near trailer 1. This change had no effect on CO at trailer 1. Also, the sensitivity study discussed above indicated no effect from increasing the hot refueling area and hot refueling delay area source sizes. In other words, some inaccuracy in aircraft source specification near trailer 1 would not cause increased concentrations at that receptor. Therefore, it appears to be a valid assumption that trailer 1 was a good background level indicator when a westerly wind prevailed, and the AQAM environ input for CO was reasonable. The model predicted that CO concentrations due to environ sources were nearly constant over the entire airbase.

To check the validity of AQAM predictions for CO emissions due to aircraft, trailer 1 measured concentrations (now assumed to be reasonable background CO) were subtracted from the measured concentrations at trailers 3 and 4. Figure 7 shows good agreement for the very limited data available. The higher predicted aircraft CO values at trailer 3 may result either

from inaccurate specification of aircraft idle CO emissions in the hot refueling area or from a too slowly spreading plume. A change of 1 in stability category input to AQAM could also significantly change the predicted concentrations at trailer 3.

In addition to predicting reasonably accurate concentrations at specific receptors, a model should also correctly predict concentration profiles across the receptor grid. A CO concentration profile across the airbase was constructed (Figure 8) to illustrate the variation in predicted concentration along the wind direction. In the two cases plotted, the wind was from 270° and the stability category was 3. The two profiles were plotted along the 8 km. y-coordinate since this y-coordinate most nearly passed through the trailer 1-4 locations. Predicted and measured trailer data that were available were also plotted. "Trailer profiles" were sketched only to indicate general trends and do not necessarily represent actual variations. The comparison shows, as expected, that the predicted trailer 1-4 variation had a much larger gradient than the 8 km. profile due to closer proximity to aircraft ground operations (taxiways, hot refueling areas, parking areas). The measured profiles for both 2 Aug and 6 Aug were similar to the predicted profiles, peaking between trailers 2 and 3. The higher predicted values at trailer 3 were discussed above.

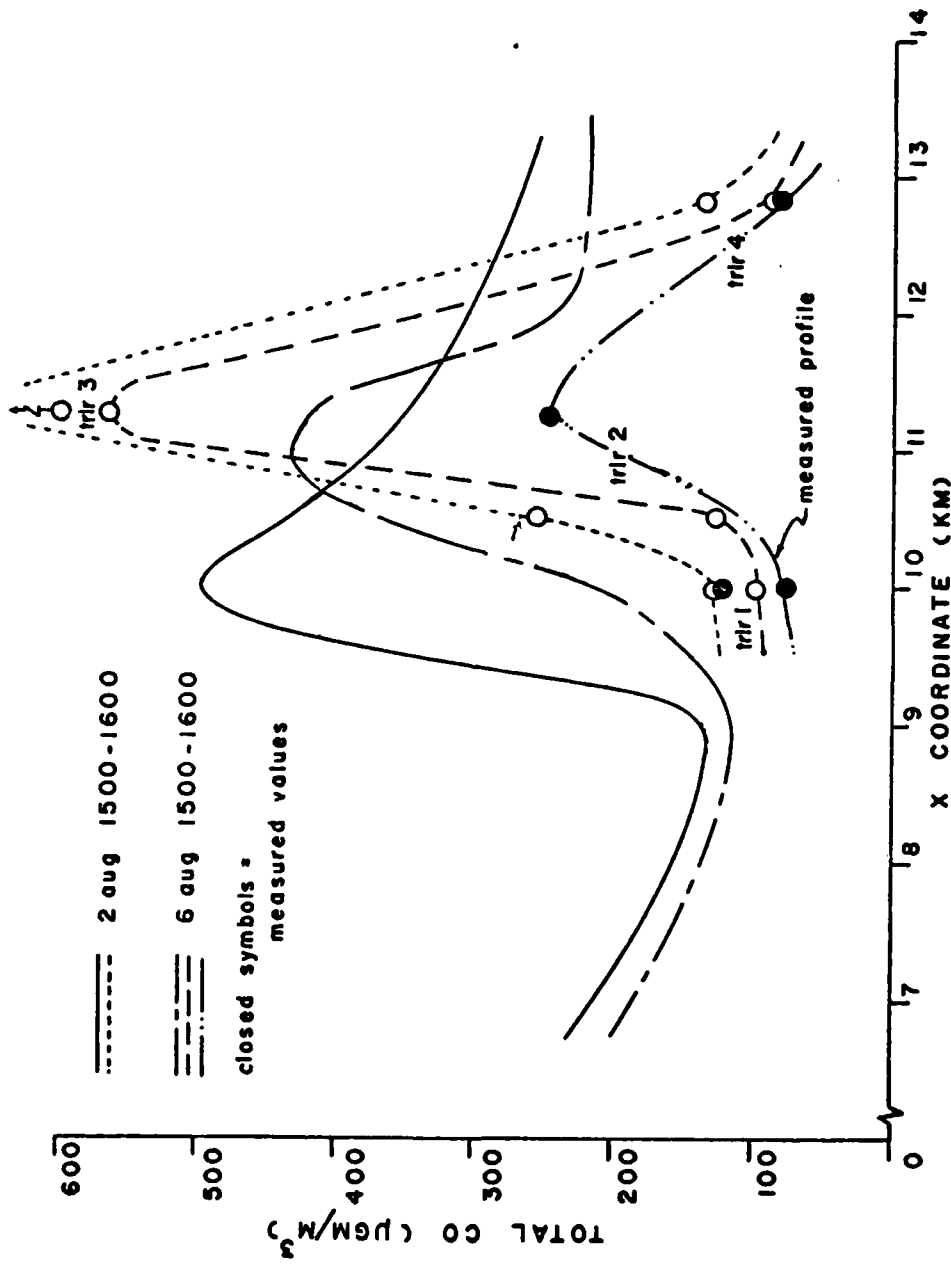

FIGURE 8
 Predicted CO Concentration Profiles Along 8 km. y-coordinate

36

2. NOX Emissions

Comparison of weekend/weekday data again permitted no significant conclusions regarding the validity of using trailer 1 as an indicator of background NOX.

Figure 9 presents measured versus predicted hourly average NOX concentrations for trailers 1, 2, and 4. (No measured data were available for trailer 3 during the ten one-hour time periods selected for validation efforts). As previously stated, the comparison was based upon an NO₂ conversion factor for ppm to $\mu\text{gm}/\text{m}^3$. Predicted concentrations from both aircraft sources alone and total sources are plotted to indicate their relative magnitudes. Predicted total concentrations at trailers 1 and 4 agreed with measured concentrations within a factor of approximately three. It should be noted that the predicted concentrations were all very small and varied much less than the measured data. Also, the measured data at trailer 2 were much greater than predicted NOX concentrations.

Because of the general agreement between trailer 1 measured and predicted concentrations, it appears that trailer 1 again provided a good representation of background concentrations. Therefore, trailer 1 measured concentrations were subtracted from those measured at trailers 2 and 4 and compared to predicted aircraft NOX emissions. Again, at trailer 2 the measured (difference) values were much greater than predicted aircraft concentrations. At trailer 4 the measured

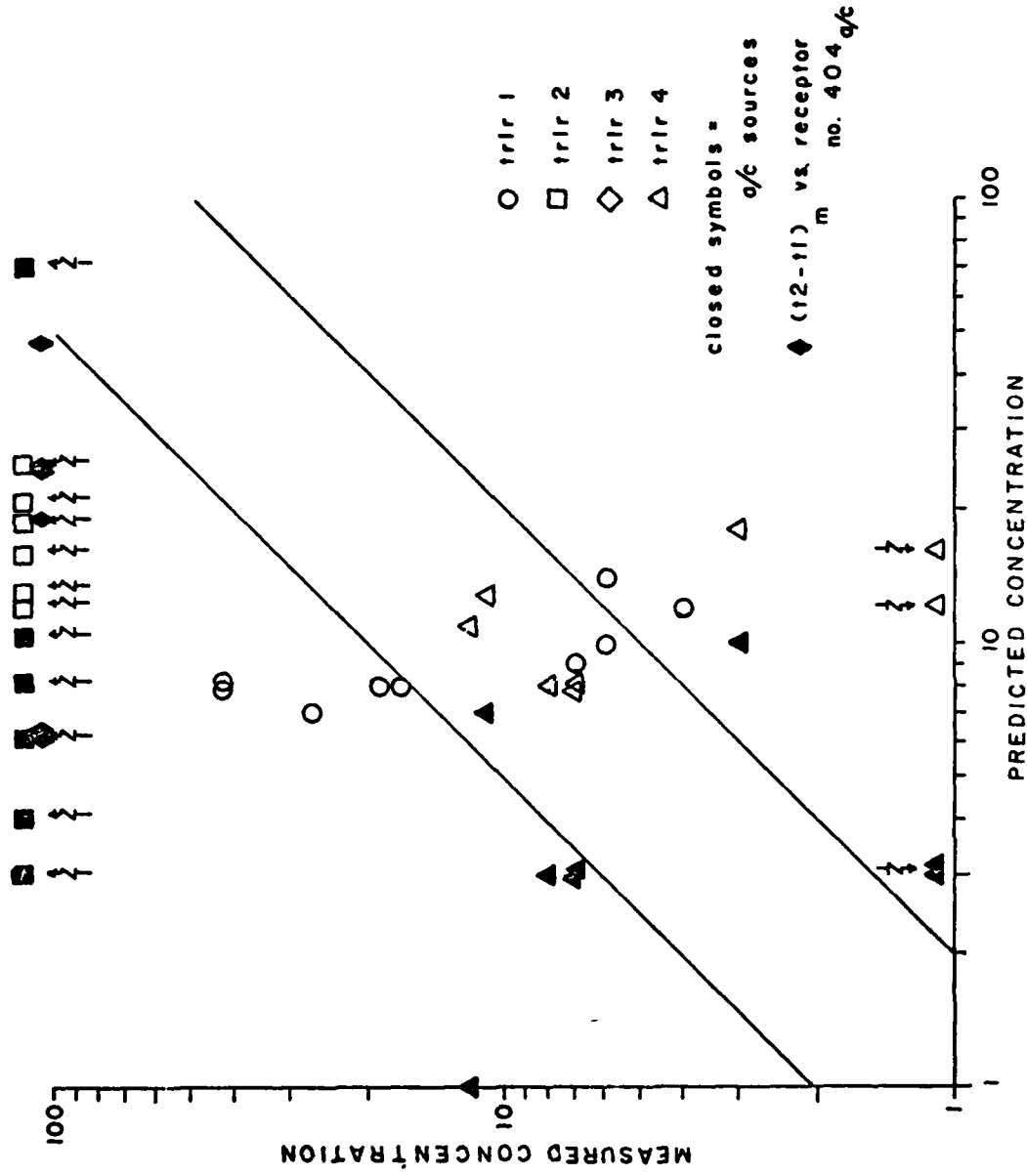

Measured vs. Predicted Hourly Average NOx Concentrations For Intensive Study
 FIGURE 9

(difference) data agreed reasonably well with predicted aircraft data (both were very small). Since trailer 4 and trailer 1 concentrations were nearly the same for both measured and predicted data, and only approximately one-half of the predicted trailer 4 values were due to aircraft, trailer 4 was probably outside most of the aircraft plumes for the existing wind conditions.

Because trailer 2 was located in a near-source region where lateral concentration gradients were large, comparisons were also made to crosswind receptor concentrations. The (trailer 2 - trailer 1)_{measured} concentrations were compared to the predicted concentrations from aircraft at special receptor 404 (100m crosswind/south of trailer 2). The predicted concentrations were still much less than measured concentrations, indicating that the predicted concentration gradients around trailer 2 were not enough to significantly improve the comparison between predictions and measurements.

These results indicate that the NOX emissions from aircraft engines specified in AQAM are too low for low power engine operations (idle and taxi). An alternative explanation is that the aircraft engine settings for aircraft located around trailer 2 (hot refueling area, taxiways, and parking areas) are well above idle, thus producing more NOX than assumed by AQAM.

3. Total Hydrocarbon (THC) Emissions

The measured versus predicted total hourly-averaged THC concentrations for trailers 1, 3 and 4 are plotted in

29

Figure 10. (No measured data were available for trailer 2). The conversion factor used for ppm to $\mu\text{gm}/\text{m}^3$ was based on CH_4 and was therefore only an approximation for total hydrocarbons. As can be seen from the figure, predicted data were significantly lower and varied much more than measured data. Measured trailer 1 concentrations were approximately 1.5 times greater than trailer 3 concentrations. This decrease is nearly the same as expected for downwind dispersion from far upwind sources (i.e., due to changes in σ_y in equation 3). These results indicate that almost all THC was probably from environ sources. AQAM predicted concentrations at trailer 3 were greater than those at trailers 1 and 4 due to aircraft ground activity. If most of the measured concentrations of THC are in fact due to environ sources and measured trailer 1 values are accurate, then AQAM values for THC emittants due to environ sources are low (i.e., land-use factors are low). This would also imply that the values used in AQAM for THC emittants from aircraft sources are too high (at trailer 3 downwind of the hot refueling area). This particular observation could have been better clarified had measured data been available from trailer 2.

4. Particulate (PT) Emissions

Figure 11 is a plot of the measured (converted bscat) versus predicted total hourly averaged PT concentrations. The measured data were within $\pm 40\%$ of the mean value. The measured values at trailers 1 and 4 were essentially the same.

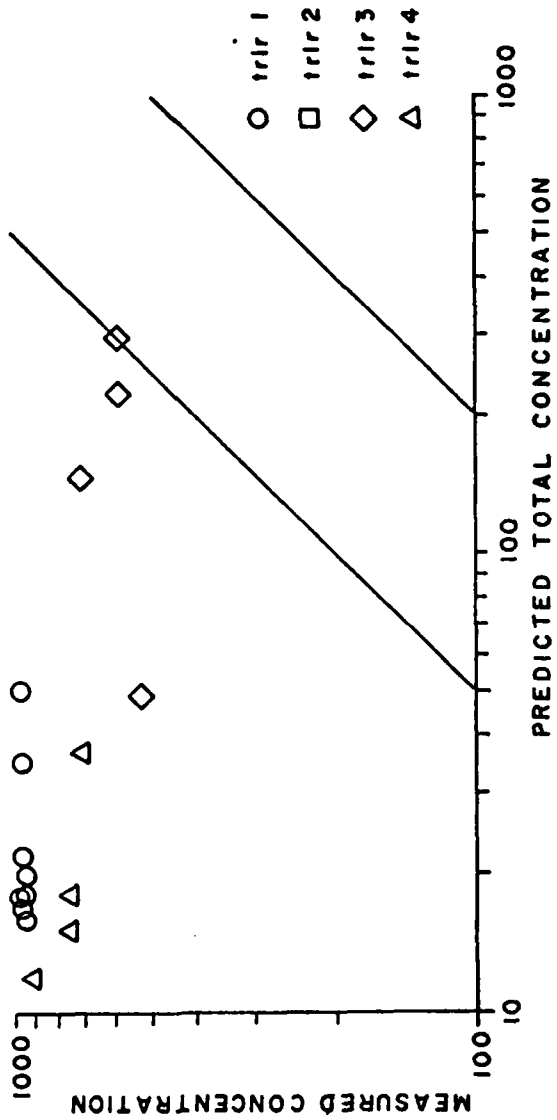
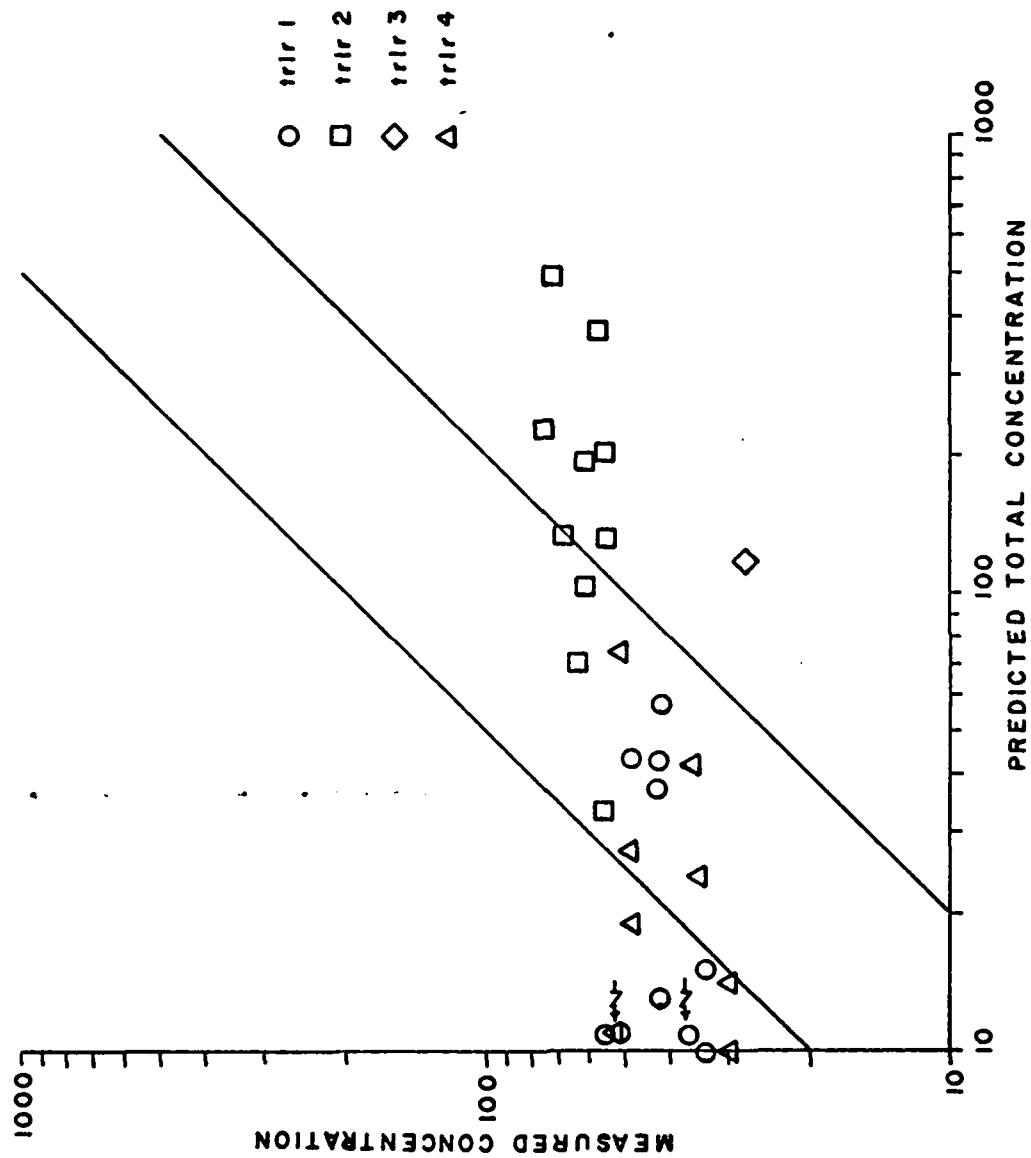

FIGURE 10
 Measured vs. Predicted Hourly Average THC Concentrations for Intensive Study



Measured vs. Predicted Hourly Average PT Concentrations for Intensive Study
 FIGURE 11

2

The comparison is fairly good (within a factor of three for 70% of the data) at trailers 1 and 4 using the aforementioned conversion factor for bscat to $\mu\text{gm}/\text{m}^3$. The model, however, appears to overpredict PT concentrations at trailer 2. AQAM predicts that most of the PT concentration is from aircraft sources. Therefore, if trailer 1 data are good indicators of background PT concentration, then AQAM has low environ source PT input (land-use factors, vehicle mileage, etc.) and/or high aircraft source PT input.

C. CONCLUSIONS AND RECOMMENDATIONS

Approximately 50% of the predicted levels of concentration were found to agree with measured levels within a factor of two. The results also indicated that: (1) predicted CO concentrations agreed quite well with measured data; (2) model predictions were too low for NOX emissions from aircraft operating in the idle/taxi mode; and (3) predicted THC and PT concentrations were too high for aircraft operating in the idle/taxi mode and/or were too low for environ sources.

For a reasonably complete model validation to be accomplished much more measured data must be obtained during a specific time period of observed meteorological and operational activity. The conclusions from this intensive study were based on very limited data and can only be considered preliminary results. Accurate data for background levels/local air quality are important for determination of aircraft source contributions to total emittants. It would be most

beneficial to obtain pollution measurements on weekends at a time when aircraft activity is low and meteorological conditions are very similar to weekday conditions. If at all possible, the next intensive effort should be conducted during a period with less variations in meteorology. Detailed data collection should begin several days before the detailed operational data are collected in order to ensure a more complete data set than was obtained in this initial effort.

APPENDIX A

Special Receptor Concentrations for Sensitivity Study

MONTH = AUG PERIOD = 0900 TO 1000 HOURS ON A WEEKDAY

RECEPTOR CONCENTRATION DATA FROM EMISION SOURCES
EXPECTED ARITHMETIC MEAN

RECEPTOR NUMBER	RECEPTOR LOCATION (KILOMETERS) X	Y	CT	MC	PC	PT	SO2
			(MICROGRAMS/CU. METER) / 10X	(MICROGRAMS/CU. METER) / 10X	(MICROGRAMS/CU. METER) / 10X	(MICROGRAMS/CU. METER) / 10X	(MICROGRAMS/CU. METER) / 10X
401	10.01	8.24	6.947E-01	1.049E-01	4.627E-01	1.964E-00	2.601E-00
402	10.52	8.46	6.691E-01	1.117E-01	4.435E-01	1.951E-00	2.814E-00
403	11.62	8.42	6.490E-01	1.117E-01	4.535E-01	1.959E-00	2.828E-00
404	10.58	8.37	6.780E-01	1.052E-01	4.839E-01	1.909E-00	2.752E-00
405	10.56	8.36	6.283E-01	1.052E-01	4.859E-01	1.922E-00	2.775E-00
409	11.24	8.35	6.324E-01	1.172E-01	5.189E-01	2.103E-00	3.049E-00
407	11.34	8.32	6.355E-01	1.054E-01	4.814E-01	1.915E-00	2.763E-00
408	11.70	8.26	5.663E-01	1.147E-01	5.065E-01	2.046E-00	2.976E-00
409	12.05	8.36	5.989E-01	1.041E-01	4.519E-01	1.773E-00	2.547E-00
410	12.42	7.31	6.046E-01	1.041E-01	4.576E-01	1.817E-00	2.633E-00
411	12.96	7.20	5.892E-01	1.017E-01	4.462E-01	1.756E-00	2.533E-00
412	12.86	7.40	6.049E-01	1.049E-01	4.559E-01	1.820E-00	2.629E-00

MONTH = AUG PERIOD = 0900 TO 1000 HOURS ON A WEEKDAY

RECEPTOR CONCENTRATION DATA FROM AIRPORT SOURCES
EXPECTED ARITHMETIC MEAN

RECEPTOR NUMBER	RECEPTOR LOCATION (KILOMETERS) X	Y	CO	PC	SO2	PT	SO2
			(MICROGRAMS/CU. METER) / 10X	(MICROGRAMS/CU. METER) / 10X	(MICROGRAMS/CU. METER) / 10X	(MICROGRAMS/CU. METER) / 10X	(MICROGRAMS/CU. METER) / 10X
401	10.01	8.24	2.124E-05	0.049E-01	1.429E-03	1.147E-08	5.746E-10
402	10.52	8.46	7.518E-05	3.045E-01	2.117E-03	1.037E-05	7.560E-05
403	11.62	8.42	1.102E-05	1.503E-01	1.699E-06	9.047E-09	7.900E-08
404	10.48	8.37	1.661E-05	2.219E-01	1.202E-02	2.097E-05	7.232E-04
405	11.50	8.36	3.597E-05	3.087E-01	2.509E-06	1.987E-02	1.085E-07
409	11.44	8.22	2.757E-05	2.547E-01	1.867E-04	3.254E-03	1.124E-03
407	11.34	8.32	3.431E-05	2.751E-01	2.735E-02	4.311E-03	1.647E-03
408	11.70	8.26	3.691E-05	3.149E-01	2.533E-02	4.431E-03	1.524E-03
409	12.05	8.36	7.075E-05	1.743E-01	1.699E-01	9.879E-03	6.878E-03
410	12.42	7.31	7.261E-05	3.429E-01	1.832E-02	1.107E-03	6.455E-04
411	12.96	7.20	7.385E-05	3.153E-01	1.839E-02	1.042E-03	7.571E-04
412	12.86	7.40	9.196E-05	3.552E-01	1.876E-02	1.632E-03	7.976E-04

Run No. 1

721 HAS BEEN
FROM COPY

MONTH = AUG NAS PERIOD = 0000 TO 1000 HOURS ON 4 WEEKDAY

RECEPTOR NUMBER	RECEPTOR LOCATION		RECEPTOR CONCENTRATION DATA FROM TOTAL SOURCES									
	(KILOMETERS)	(METERS)	EXPECTED ARITHMETIC MEAN									
			CO	HC	NOX	SO ₂	PT	PT	PT	PT	PT	PT
401	10.01	8.24	6.04E 01	1.04E 01	4.42E 00	1.804E 00	1.804E 00	1.804E 00	1.804E 00	1.804E 00	1.804E 00	1.804E 00
402	10.52	8.26	5.80E 01	1.23E 01	5.22E 00	1.534E 01	1.534E 01	1.534E 01	1.534E 01	1.534E 01	1.534E 01	1.534E 01
403	10.62	8.42	7.48E 01	2.47E 01	6.61E 00	2.65E 01	2.65E 01	2.65E 01	2.65E 01	2.65E 01	2.65E 01	2.65E 01
404	10.48	8.57	1.124E 02	2.455E 02	8.474E 01	1.078E 02	1.078E 02	1.078E 02	1.078E 02	1.078E 02	1.078E 02	1.078E 02
405	10.52	8.56	1.089E 02	5.53E 01	8.852E 00	1.801E 01	1.801E 01	1.801E 01	1.801E 01	1.801E 01	1.801E 01	1.801E 01
406	11.24	8.23	1.07E 02	4.502E 01	1.134E 01	8.045E 01	8.045E 01	8.045E 01	8.045E 01	8.045E 01	8.045E 01	8.045E 01
407	11.54	8.32	3.782E 02	1.12E 02	4.21E 01	3.32E 02	3.32E 02	3.32E 02	3.32E 02	3.32E 02	3.32E 02	3.32E 02
408	11.20	8.26	2.019E 02	1.268E 02	1.77E 01	2.426E 02	2.426E 02	2.426E 02	2.426E 02	2.426E 02	2.426E 02	2.426E 02
409	12.02	8.36	3.556E 03	1.354E 03	4.215E 02	2.708E 03	2.708E 03	2.708E 03	2.708E 03	2.708E 03	2.708E 03	2.708E 03
410	12.82	7.81	8.259E 01	1.810E 01	9.200E 00	3.772E 01	3.772E 01	3.772E 01	3.772E 01	3.772E 01	3.772E 01	3.772E 01
411	12.52	7.50	8.408E 01	1.539E 01	1.059E 01	3.210E 01	3.210E 01	3.210E 01	3.210E 01	3.210E 01	3.210E 01	3.210E 01
412	12.82	7.40	3.613E 01	2.012E 01	1.011E 01	3.094E 01	3.094E 01	3.094E 01	3.094E 01	3.094E 01	3.094E 01	3.094E 01

RECEIVED AT THE AIR QUALITY CONTROL DISTRICT OFFICE

Run No. 1

MONTH = AUG WAS MIRAMAR PERIOD = 0900 TO 1000 HOURS ON A WEEKDAY

RECEPTOR NUMBER	RECEPTOR LOCATION		RECEPTOR CONCENTRATION DATA FROM AIRCRAFT SOURCES													
	X (KILOMETERS)	Y	CJ	HC	HC (MICROGRAMS/CU. METER)	PT	CCZ	HC	HC (MICROGRAMS/CU. METER)	PT	CCZ	HC	HC (MICROGRAMS/CU. METER)	PT	CCZ	
401	10.01	8.24	9.349E-02	2.554E-05	1.267E-05	5.574E-04	1.763E-06	1.267E-05	5.574E-04	1.763E-06	1.267E-05	5.574E-04	1.763E-06	1.267E-05	5.574E-04	1.763E-06
402	10.52	8.45	3.175E-02	5.941E-01	2.833E-01	1.335E-01	3.631E-02	2.833E-01	1.335E-01	3.631E-02	2.833E-01	1.335E-01	3.631E-02	2.833E-01	1.335E-01	3.631E-02
403	10.62	8.42	2.99E-01	1.224E-01	1.578E-01	2.538E-01	3.64E-02	1.578E-01	2.538E-01	3.64E-02	1.578E-01	2.538E-01	3.64E-02	1.578E-01	2.538E-01	3.64E-02
404	10.48	8.37	4.807E-01	1.423E-01	3.562E-01	1.059E-02	2.555E-01	1.423E-01	3.562E-01	1.059E-02	2.555E-01	1.423E-01	3.562E-01	1.059E-02	2.555E-01	1.423E-01
405	10.58	8.36	4.501E-01	1.568E-01	3.556E-01	1.781E-02	5.230E-01	1.568E-01	3.556E-01	1.781E-02	5.230E-01	1.568E-01	3.556E-01	1.781E-02	5.230E-01	1.568E-01
406	11.24	8.35	9.846E-01	2.433E-01	6.138E-01	7.335E-01	6.483E-02	2.433E-01	6.138E-01	7.335E-01	6.483E-02	2.433E-01	6.138E-01	7.335E-01	6.483E-02	2.433E-01
407	11.34	8.32	3.142E-02	1.550E-02	1.133E-01	3.305E-01	9.819E-01	1.550E-02	1.133E-01	3.305E-01	9.819E-01	1.550E-02	1.133E-01	3.305E-01	9.819E-01	1.550E-02
408	11.20	9.25	2.247E-02	1.123E-02	1.265E-01	2.405E-02	6.935E-01	1.123E-02	1.265E-01	2.405E-02	6.935E-01	1.123E-02	1.265E-01	2.405E-02	6.935E-01	1.123E-02
409	12.05	8.36	3.575E-01	1.482E-03	4.172E-02	2.302E-01	9.801E-01	1.482E-03	4.172E-02	2.302E-01	9.801E-01	1.482E-03	4.172E-02	2.302E-01	9.801E-01	1.482E-03
410	12.82	7.31	2.212E-01	8.055E-03	4.675E-01	2.350E-01	6.787E-02	8.055E-03	4.675E-01	2.350E-01	6.787E-02	8.055E-03	4.675E-01	2.350E-01	6.787E-02	8.055E-03
411	12.32	7.50	2.509E-01	3.903E-01	6.107E-01	3.639E-01	7.768E-02	3.903E-01	6.107E-01	3.639E-01	7.768E-02	3.903E-01	6.107E-01	3.639E-01	7.768E-02	3.903E-01
412	12.86	7.40	2.559E-01	5.245E-01	5.509E-01	2.912E-01	7.443E-02	5.245E-01	5.509E-01	2.912E-01	7.443E-02	5.245E-01	5.509E-01	2.912E-01	7.443E-02	5.245E-01

MONTH = AUG WAS MIRAMAR PERIOD = 0900 TO 1000 HOURS ON A WEEKDAY

RECEPTOR NUMBER	RECEPTOR LOCATION		RECEPTOR CONCENTRATION DATA FROM AIRCRAFT SOURCES													
	X (KILOMETERS)	Y	CJ	HC	HC (MICROGRAMS/CU. METER)	PT	CCZ	HC	HC (MICROGRAMS/CU. METER)	PT	CCZ	HC	HC (MICROGRAMS/CU. METER)	PT	CCZ	
401	10.01	8.24	1.565E-05	2.802E-06	2.738E-06	3.035E-04	6.779E-07	2.802E-06	2.738E-06	3.035E-04	6.779E-07	2.802E-06	2.738E-06	3.035E-04	6.779E-07	2.802E-06
402	10.52	8.45	4.648E-02	7.225E-02	2.422E-02	8.725E-01	1.318E-02	7.225E-02	2.422E-02	8.725E-01	1.318E-02	7.225E-02	2.422E-02	8.725E-01	1.318E-02	7.225E-02
403	10.62	8.42	3.163E-01	5.922E-01	2.537E-01	9.274E-01	1.273E-02	5.922E-01	2.537E-01	9.274E-01	1.273E-02	5.922E-01	2.537E-01	9.274E-01	1.273E-02	5.922E-01
404	10.48	8.37	7.327E-01	2.158E-02	4.259E-01	5.823E-01	4.549E-02	2.158E-02	4.259E-01	5.823E-01	4.549E-02	2.158E-02	4.259E-01	5.823E-01	4.549E-02	2.158E-02
405	10.58	8.36	4.135E-01	2.403E-01	4.511E-01	3.863E-01	1.587E-01	2.403E-01	4.511E-01	3.863E-01	1.587E-01	2.403E-01	4.511E-01	3.863E-01	1.587E-01	2.403E-01
406	11.24	8.35	3.057E-01	7.021E-01	5.413E-01	5.738E-01	3.081E-02	7.021E-01	5.413E-01	5.738E-01	3.081E-02	7.021E-01	5.413E-01	5.738E-01	3.081E-02	7.021E-01
407	11.34	8.32	3.035E-01	9.215E-01	7.817E-01	9.542E-01	3.620E-01	9.215E-01	7.817E-01	9.542E-01	3.620E-01	9.215E-01	7.817E-01	9.542E-01	3.620E-01	9.215E-01
408	11.20	9.25	7.709E-01	5.013E-01	7.132E-01	9.212E-01	1.453E-01	5.013E-01	7.132E-01	9.212E-01	1.453E-01	5.013E-01	7.132E-01	9.212E-01	1.453E-01	5.013E-01
409	12.05	8.36	3.633E-01	3.913E-01	5.883E-01	9.303E-01	7.033E-01	3.913E-01	5.883E-01	9.303E-01	7.033E-01	3.913E-01	5.883E-01	9.303E-01	7.033E-01	3.913E-01
410	12.82	7.31	2.673E-01	4.332E-01	5.065E-01	9.343E-01	2.512E-02	4.332E-01	5.065E-01	9.343E-01	2.512E-02	4.332E-01	5.065E-01	9.343E-01	2.512E-02	4.332E-01
411	12.32	7.50	2.982E-01	4.575E-01	5.763E-01	7.453E-01	2.974E-02	4.575E-01	5.763E-01	7.453E-01	2.974E-02	4.575E-01	5.763E-01	7.453E-01	2.974E-02	4.575E-01
412	12.86	7.40	2.960E-01	4.556E-01	5.450E-01	5.911E-01	2.752E-02	4.556E-01	5.450E-01	5.911E-01	2.752E-02	4.556E-01	5.450E-01	5.911E-01	2.752E-02	4.556E-01

Run No. 1

74

THIS REPORT IS UNCLASSIFIED
FROM 001 PERIODS TO 000

MONTH = AUG HAS MIPAMAR PERIOD = 0900 TO 1000 HOURS ON A WEEKDAY

RECEPTOR CONCENTRATION DATA FROM AIRCRAFT SOURCES									
RECEPTOR NUMBER	RECEPTOR LOCATION	EXPECTED ARITHMETIC MEAN							
	(KILOMETERS)	A	CO	HC	NOX	PT	SO2		
				(MICROGRAMS/CU. METER)					
401	10.01	8.24	2.27E 00	1.03E 00	3.41E 01	1.96E 01	6.15E -02		
412	10.52	8.46	5.45E 01	2.40E 01	2.36E 00	5.28E 01	1.36E -01		
403	10.43	8.42	8.35E 01	4.07E 01	4.95E 00	5.25E 01	3.75E -02		
405	10.58	8.36	8.47E 01	3.66E 01	5.01E 00	1.27E 02	3.02E -01		
406	11.24	8.35	8.81E 01	3.06E 01	3.16E 00	6.52E 01	1.55E -01		
407	11.33	8.32	1.20E 02	4.55E 01	7.76E 00	7.67E 01	4.65E -02		
409	11.20	8.26	2.27E 02	1.43E 02	1.01E 01	2.34E 02	8.80E -01		
410	12.05	8.36	2.69E 02	1.43E 02	1.47E 01	2.95E 02	9.46E -01		
411	12.36	7.31	9.27E 02	1.56E 02	1.93E 02	5.71E 02	2.27E 00		
412	12.86	7.50	2.08E 01	7.44E 00	4.43E 00	2.37E 01	6.01E -02		
		7.50	2.05E 01	7.43E 00	4.75E 00	2.46E 01	6.18E -02		
		7.40	2.36E 01	8.70E 00	4.75E 00	2.54E 01	6.41E -02		

MONTH = AUG HAS MIPAMAR PERIOD = 0900 TO 1000 HOURS ON A WEEKDAY

RECEPTOR CONCENTRATION DATA FROM AIRCRAFT SOURCES									
RECEPTOR NUMBER	RECEPTOR LOCATION	FRACTION OF TOTAL							
	(KILOMETERS)	A	CO	HC	NOX	PT	SO2		
401	10.01	8.24	0.30E -02	9.47E -02	1.26E -02	5.15E -01	2.66E -02		
402	10.52	8.46	4.74E -01	7.13E -01	3.67E -01	9.60E -01	4.76E -02		
403	10.43	8.42	5.79E -01	7.12E -01	4.66E -01	5.67E -01	3.24E -02		
405	10.58	8.36	5.27E -01	3.54E -01	5.55E -01	9.87E -01	1.64E -01		
406	11.24	8.35	2.67E -01	3.54E -01	4.09E -01	5.73E -01	5.77E -02		
407	11.33	8.32	6.35E -01	9.00E -01	6.13E -01	9.75E -01	1.70E -02		
409	11.20	8.26	8.29E -01	5.26E -01	7.81E -01	5.54E -01	2.58E -01		
410	12.05	8.36	9.11E -01	9.25E -01	7.54E -01	9.93E -01	2.56E -01		
411	12.36	7.31	9.36E -01	2.41E -01	5.76E -01	5.96E -01	4.67E -01		
412	12.86	7.50	2.23E -01	4.12E -01	4.46E -01	9.17E -01	1.95E -02		
		7.50	2.56E -01	4.12E -01	5.11E -01	5.41E -01	2.29E -02		
		7.40	2.43E -01	3.94E -01	4.63E -01	9.23E -01	2.18E -02		

MONTH = AUG NAS MIRAMAR PERIOD = 0900 TO 1000 HOURS ON A WEEKDAY

RECEPTOR NUMBER	RECEPTOR LOCATION		RECEPTOR CONCENTRATION DATA FROM AIRCRAFT SOURCES										EXPECTED ARITHMETIC MEAN				
	(KILOMETERS) X	(KILOMETERS) Y	CD	HC	NIX	PT	SC2	CD	HC	NIX	PT	SC2	CD	HC	NIX	PT	SC2
401	10.01	8.24	4.59E 00	1.45E 00	4.63E 01	2.78E 01	8.77E 02	4.59E 00	1.45E 00	4.63E 01	2.78E 01	8.77E 02	4.59E 00	1.45E 00	4.63E 01	2.78E 01	8.77E 02
402	10.52	4.96	6.76E 01	4.77E 01	5.77E 01	1.94E 02	5.77E 01	6.83E 01	4.83E 01	5.83E 01	2.25E 02	9.25E 01	6.83E 01	4.83E 01	5.83E 01	2.25E 02	9.25E 01
403	10.62	8.62	1.41E 02	6.83E 01	7.55E 01	1.72E 02	1.41E 02	1.41E 02	1.41E 02	1.41E 02	1.41E 02	1.41E 02	1.41E 02	1.41E 02	1.41E 02	1.41E 02	1.41E 02
404	10.52	8.37	1.41E 02	5.14E 01	7.26E 01	3.25E 02	1.41E 02	1.41E 02	1.41E 02	1.41E 02	1.41E 02	1.41E 02	1.41E 02	1.41E 02	1.41E 02	1.41E 02	1.41E 02
405	10.52	8.36	1.19E 02	5.65E 01	7.04E 01	2.28E 02	1.19E 02	1.19E 02	1.19E 02	1.19E 02	1.19E 02	1.19E 02	1.19E 02	1.19E 02	1.19E 02	1.19E 02	1.19E 02
406	11.24	8.35	7.45E 02	9.57E 01	1.53E 01	1.62E 02	7.45E 02	7.45E 02	7.45E 02	7.45E 02	7.45E 02	7.45E 02	7.45E 02	7.45E 02	7.45E 02	7.45E 02	7.45E 02
407	11.24	8.32	7.44E 02	2.20E 02	2.53E 01	4.24E 02	7.44E 02	7.44E 02	7.44E 02	7.44E 02	7.44E 02	7.44E 02	7.44E 02	7.44E 02	7.44E 02	7.44E 02	7.44E 02
408	11.24	8.26	3.66E 02	1.76E 02	2.05E 01	3.66E 02	3.66E 02	3.66E 02	3.66E 02	3.66E 02	3.66E 02	3.66E 02	3.66E 02	3.66E 02	3.66E 02	3.66E 02	3.66E 02
409	12.05	8.36	1.37E 03	2.45E 02	1.56E 02	6.60E 02	1.37E 03	1.37E 03	1.37E 03	1.37E 03	1.37E 03	1.37E 03	1.37E 03	1.37E 03	1.37E 03	1.37E 03	1.37E 03
410	12.82	7.31	3.61E 01	1.30E 01	1.00E 01	5.00E 01	3.61E 01	3.61E 01	3.61E 01	3.61E 01	3.61E 01	3.61E 01	3.61E 01	3.61E 01	3.61E 01	3.61E 01	3.61E 01
411	12.82	7.50	5.22E 01	1.69E 01	1.36E 01	6.79E 01	5.22E 01	5.22E 01	5.22E 01	5.22E 01	5.22E 01	5.22E 01	5.22E 01	5.22E 01	5.22E 01	5.22E 01	5.22E 01
412	12.82	7.40	4.30E 01	1.53E 01	9.62E 00	5.16E 01	4.30E 01	4.30E 01	4.30E 01	4.30E 01	4.30E 01	4.30E 01	4.30E 01	4.30E 01	4.30E 01	4.30E 01	4.30E 01

MONTH = AUG NAS MIRAMAR PERIOD = 0900 TO 1000 HOURS ON A WEEKDAY

RECEPTOR NUMBER	RECEPTOR LOCATION		RECEPTOR CONCENTRATION DATA FROM AIRCRAFT SOURCES										EXPECTED ARITHMETIC MEAN				
	(KILOMETERS) X	(KILOMETERS) Y	CD	HC	NIX	PT	SC2	CD	HC	NIX	PT	SC2	CD	HC	NIX	PT	SC2
401	10.01	8.24	5.26E 02	1.06E 01	7.62E 02	9.25E 01	5.26E 02	5.26E 02	5.26E 02	5.26E 02	5.26E 02	5.26E 02	5.26E 02	5.26E 02	5.26E 02	5.26E 02	5.26E 02
402	10.52	8.46	5.46E 01	7.63E 01	4.78E 01	5.47E 01	5.46E 01	5.46E 01	5.46E 01	5.46E 01	5.46E 01	5.46E 01	5.46E 01	5.46E 01	5.46E 01	5.46E 01	5.46E 01
403	10.52	8.42	6.37E 01	8.21E 01	5.46E 01	9.86E 01	6.37E 01	6.37E 01	6.37E 01	6.37E 01	6.37E 01	6.37E 01	6.37E 01	6.37E 01	6.37E 01	6.37E 01	6.37E 01
404	10.52	8.36	6.63E 01	4.83E 01	5.34E 01	7.30E 01	6.63E 01	6.63E 01	6.63E 01	6.63E 01	6.63E 01	6.63E 01	6.63E 01	6.63E 01	6.63E 01	6.63E 01	6.63E 01
406	11.24	8.32	7.45E 01	8.54E 01	7.03E 01	9.64E 01	7.45E 01	7.45E 01	7.45E 01	7.45E 01	7.45E 01	7.45E 01	7.45E 01	7.45E 01	7.45E 01	7.45E 01	7.45E 01
407	11.24	8.32	8.51E 01	5.31E 01	5.68E 01	7.94E 01	8.51E 01	8.51E 01	8.51E 01	8.51E 01	8.51E 01	8.51E 01	8.51E 01	8.51E 01	8.51E 01	8.51E 01	8.51E 01
408	11.24	8.26	8.19E 01	9.03E 01	7.03E 01	9.64E 01	8.19E 01	8.19E 01	8.19E 01	8.19E 01	8.19E 01	8.19E 01	8.19E 01	8.19E 01	8.19E 01	8.19E 01	8.19E 01
409	12.05	8.36	9.37E 01	8.65E 01	5.77E 01	5.96E 01	9.37E 01	9.37E 01	9.37E 01	9.37E 01	9.37E 01	9.37E 01	9.37E 01	9.37E 01	9.37E 01	9.37E 01	9.37E 01
410	12.82	7.31	3.26E 01	4.97E 01	6.25E 01	9.00E 01	3.26E 01	3.26E 01	3.26E 01	3.26E 01	3.26E 01	3.26E 01	3.26E 01	3.26E 01	3.26E 01	3.26E 01	3.26E 01
411	12.82	7.50	4.68E 01	2.01E 01	7.47E 01	9.74E 01	4.68E 01	4.68E 01	4.68E 01	4.68E 01	4.68E 01	4.68E 01	4.68E 01	4.68E 01	4.68E 01	4.68E 01	4.68E 01
412	12.82	7.40	3.48E 01	5.14E 01	6.16E 01	9.61E 01	3.48E 01	3.48E 01	3.48E 01	3.48E 01	3.48E 01	3.48E 01	3.48E 01	3.48E 01	3.48E 01	3.48E 01	3.48E 01

MONTH = AUG PERIOD = 0900 TO 1000 HOURS IN A WEEKDAY

ACCEPTOR CONCENTRATION DATA FROM AIRCRAFT SOURCES

RECEPTOR NUMBER RECEPTOR LOCATION EXPECTED ARITHMETIC MEAN

RECEPTOR NUMBER	RECEPTOR LOCATION	(KILOMETERS)	(MICROGRAMS/CU. METER)					PT	SC2
			CO	HC	NOX	PT	SC2		
401		10.01	9.314E-05	2.950E-05	1.220E-05	5.507E-04		1.756E-06	
402		10.52	3.170E-02	3.941E-01	2.830E-01	1.337E-01		3.931E-02	
403		10.62	2.950E-01	1.220E-01	1.673E-00	2.503E-01		3.646E-02	
404		10.43	4.364E-01	1.425E-01	3.642E-00	1.059E-01		2.555E-01	
405		10.56	4.501E-01	1.367E-01	3.947E-00	1.701E-02		5.230E-01	
406		11.24	9.510E-01	3.220E-01	6.029E-00	1.901E-01		6.420E-02	
407		11.34	3.200E-02	1.523E-02	1.753E-01	3.314E-02		9.820E-01	
408		11.20	2.200E-02	1.052E-02	1.250E-01	2.401E-02		8.936E-01	
409		12.05	3.582E-02	1.389E-03	4.177E-02	2.710E-03		9.809E-00	
410		12.32	2.850E-01	1.043E-01	3.545E-00	3.377E-01		3.802E-02	
411		12.38	3.033E-01	1.095E-01	6.787E-00	3.755E-01		9.746E-02	
412		12.85	3.225E-01	1.177E-01	6.755E-00	3.714E-01		9.550E-02	

MONTH = AUG PERIOD = 0900 TO 1000 HOURS IN A WEEKDAY

RECEPTOR CONCENTRATION DATA FROM AIRCRAFT SOURCES

RECEPTOR NUMBER RECEPTOR LOCATION FRACTION OF TOTAL

RECEPTOR NUMBER	RECEPTOR LOCATION	(KILOMETERS)	FRACTION OF TOTAL					PT	SC2
			CO	HC	NOX	PT	SC2		
401		10.01	1.091E-05	2.561E-06	2.372E-06	2.510E-06		8.435E-07	
402		10.52	4.475E-02	6.655E-02	5.377E-02	8.779E-02		1.476E-02	
403		10.62	3.050E-01	6.355E-01	2.690E-01	9.297E-01		1.366E-02	
404		10.43	4.150E-01	3.777E-01	4.370E-01	5.820E-01		8.703E-02	
405		10.56	3.760E-01	2.427E-01	4.367E-01	9.392E-01		1.625E-01	
406		11.24	5.742E-01	5.894E-01	5.735E-01	9.754E-01		2.700E-02	
407		11.34	7.507E-01	9.333E-01	7.501E-01	9.927E-01		2.195E-01	
408		11.20	7.579E-01	3.575E-01	7.013E-01	5.518E-01		1.941E-01	
409		12.05	9.775E-01	9.374E-01	9.852E-01	9.991E-01		7.330E-01	
410		12.32	3.635E-01	4.230E-01	4.547E-01	5.444E-01		2.680E-02	
411		12.38	3.304E-01	3.527E-01	5.367E-01	9.417E-01		2.621E-02	
412		12.85	2.877E-01	4.511E-01	5.270E-01	5.351E-01		2.665E-02	

MONTH = AUG PERIOD = 0900 TO 1000 HOURS ON A WEEKDAY

RECEIVER CONCENTRATION DATA FROM AIRCRAFT SOURCES
 EXPECTED ARITHMETIC MEAN

RECEIVER NUMBER	RECEIVER LOCATION (KILOMETERS)	Y	C1	HC	FX	PT	502
401	10.01	8.24	9.391E-03	2.90E-03	1.30E-05	2.52E-04	1.77E-00
402	10.52	8.46	5.17E-03	8.56E-01	2.80E-01	1.35E-01	3.93E-02
403	10.62	8.42	2.95E-01	1.22E-01	1.67E-00	2.90E-01	3.66E-02
404	10.48	8.27	4.86E-01	1.42E-01	3.62E-00	1.95E-02	2.58E-01
405	10.55	8.36	4.50E-01	1.26E-01	3.55E-00	1.70E-02	5.23E-01
406	11.24	8.35	9.84E-01	3.43E-01	6.13E-00	7.83E-01	6.40E-02
407	11.34	8.32	3.12E-02	1.59E-02	1.73E-01	3.20E-02	5.11E-01
408	11.28	8.26	7.24E-02	1.12E-02	1.20E-01	2.40E-02	5.93E-01
409	12.05	8.39	3.57E-03	1.32E-03	4.17E-02	2.70E-03	9.80E-03
410	12.62	7.31	1.51E-01	6.63E-00	5.23E-00	2.15E-01	5.73E-02
411	12.35	7.50	2.35E-01	8.27E-00	2.67E-00	2.75E-01	7.05E-02
412	12.86	7.40	2.20E-01	6.12E-00	5.13E-00	2.52E-01	6.41E-02

MONTH = AUG PERIOD = 0900 TO 1000 HOURS ON A WEEKDAY

RECEIVER CONCENTRATION DATA FROM AIRCRAFT SOURCES
 FRACTION OF TOTAL

RECEIVER NUMBER	RECEIVER LOCATION (KILOMETERS)	Y	C1	FC	FX	PT	502
401	10.01	8.24	1.34E-03	3.34E-06	3.34E-08	3.62E-04	8.61E-01
402	10.52	8.46	2.91E-02	5.29E-02	6.26E-02	3.37E-01	1.57E-02
403	10.62	8.42	3.57E-01	5.20E-01	2.83E-01	9.35E-01	1.46E-02
404	10.48	8.27	4.74E-01	2.81E-01	4.70E-01	9.87E-01	9.51E-02
405	10.55	8.36	4.50E-01	2.53E-01	2.50E-01	9.50E-01	1.78E-01
406	11.24	8.35	6.27E-01	7.50E-01	5.75E-01	5.77E-01	2.38E-02
407	11.34	8.32	3.52E-01	9.29E-01	8.05E-01	5.91E-01	2.92E-01
408	11.28	8.26	7.67E-01	9.14E-01	7.47E-01	7.97E-01	2.12E-01
409	12.05	8.39	1.66E-01	9.22E-01	5.50E-01	9.95E-01	0.22E-01
410	12.62	7.31	2.83E-01	4.45E-01	3.97E-01	9.70E-01	2.66E-02
411	12.35	7.50	3.30E-01	4.95E-01	3.24E-01	9.51E-01	3.55E-02
412	12.86	7.40	3.17E-01	4.81E-01	5.81E-01	5.45E-01	2.95E-02

PCFH = 410 0000 TO 1000 HOURS 11 A WEDNESDAY

RECEPTOR CONCENTRATION DATA FROM AIRCRAFT SOURCES
EXPECTED ARITHMETIC MEAN

RECEPTOR NUMBER	RECEPTOR LOCATION	(KILOMETERS)			(MICROGRAMS/CU. METER)			PT	SCZ
		X	Y	Z	MC	MAX	CC		
411		10.01	8.24	1.320E-04	1.534E-06	7.770E-01	-1.357E-04	-2.107E-07	
412		11.52	8.46	8.846E-01	2.825E-01	6.315E-01	2.200E-02	8.113E-01	
403		10.62	8.42	1.100E-02	5.324E-01	5.674E-00	1.555E-02	4.631E-01	
404		10.40	8.37	1.471E-02	4.417E-01	1.184E-01	4.977E-02	1.050E-01	
405		10.58	8.36	1.454E-02	8.014E-01	5.681E-00	2.855E-02	7.142E-01	
406		11.24	8.25	2.400E-02	7.074E-01	1.454E-01	1.874E-02	1.979E-01	
407		11.24	8.32	5.914E-02	4.623E-02	4.874E-01	5.564E-02	2.573E-01	
408		11.21	8.26	6.749E-02	3.453E-02	3.651E-01	7.343E-02	2.210E-01	
409		12.05	8.20	2.151E-03	5.160E-02	4.218E-02	1.376E-03	5.466E-00	
410		12.52	7.31	4.927E-01	1.906E-01	5.289E-00	4.550E-01	1.259E-01	
411		12.32	7.53	4.977E-01	1.743E-01	1.233E-01	5.792E-01	1.343E-01	
412		12.60	7.60	5.462E-01	2.015E-01	1.104E-01	5.715E-01	1.488E-01	

PCFH = 410 1000 HOURS = 0900 TO 1000 HOURS 11 A WEDNESDAY

RECEPTOR CONCENTRATION DATA FROM AIRCRAFT SOURCES
FUNCTION CF/TOTAL

RECEPTOR NUMBER	RECEPTOR LOCATION	(KILOMETERS)			(KILOMETERS)			PT	SCZ
		X	Y	Z	MC	MIX			
401		10.01	8.24	1.320E-04	1.534E-06	5.163E-03	-3.802E-05	-3.959E-03	
402		11.52	8.46	8.846E-01	2.825E-01	3.832E-01	5.924E-01	5.542E-02	
403		10.62	8.42	1.100E-02	5.324E-01	3.030E-01	5.755E-01	7.353E-02	
404		10.40	8.37	1.471E-02	4.417E-01	1.187E-01	5.400E-01	1.618E-01	
405		10.58	8.36	1.454E-02	8.014E-01	2.974E-01	9.394E-01	1.115E-01	
406		11.24	8.25	2.400E-02	7.074E-01	2.701E-01	9.705E-01	3.069E-02	
407		11.24	8.32	5.914E-02	4.623E-02	5.410E-01	5.499E-01	3.427E-01	
408		11.21	8.26	6.749E-02	3.453E-02	7.621E-01	5.843E-01	2.710E-01	
409		12.05	8.20	2.151E-03	5.160E-02	5.770E-01	5.701E-01	5.020E-01	
410		12.52	7.31	4.927E-01	1.906E-01	1.233E-01	5.660E-01	2.274E-02	
411		12.32	7.53	4.977E-01	1.743E-01	5.674E-01	9.566E-01	2.518E-02	
412		12.60	7.60	5.462E-01	2.015E-01	5.379E-01	9.362E-01	2.615E-02	

MODEL = ALO HAS MIRAMAR = 0900 TO 1000 HOURS ON A WEEKDAY

RECEPTOR NUMBER	RECEPTOR LOCATION		RECEPTOR CONCENTRATION DATA FROM AIRPORT SOURCES																	
	(KILOMETERS) X	(KILOMETERS) Y	CO	HC	NOX	PT	SO2	EXPECTED ASYMMETRIC MEAN												
401	13.01	8.24	2.240E-01	6.431E-01	2.143E-01	1.234E-01	1.506E-02													
402	10.52	8.66	4.249E-01	2.351E-01	1.754E-01	1.687E-01	2.620E-02													
403	10.62	8.42	5.184E-01	2.782E-01	2.184E-01	1.966E-01	2.433E-02													
404	10.58	8.37	7.633E-01	2.710E-01	2.341E-01	7.823E-01	1.703E-01													
405	10.58	8.36	4.377E-01	2.149E-01	2.203E-01	4.661E-01	5.116E-02													
406	11.24	8.35	7.828E-01	2.554E-01	4.582E-01	5.747E-01	9.327E-02													
407	11.34	8.32	2.037E-02	1.033E-02	1.126E-01	2.170E-02	4.505E-01													
408	11.20	8.26	1.933E-02	7.647E-01	8.649E-01	1.015E-02	9.629E-01													
409	12.05	8.36	6.225E-02	1.240E-02	1.266E-02	3.774E-02	1.478E-00													
410	12.52	7.31	1.485E-01	5.263E-03	2.139E-00	1.740E-01	4.560E-02													
411	12.56	7.50	1.689E-01	5.946E-03	2.072E-00	2.026E-01	5.206E-02													
412	12.86	7.40	1.715E-01	6.173E-03	3.638E-00	1.644E-01	4.989E-02													

MODEL = ALO HAS MIRAMAR = 0900 TO 1000 HOURS ON A WEEKDAY

RECEPTOR NUMBER	RECEPTOR LOCATION		RECEPTOR CONCENTRATION DATA FROM AIRPORT SOURCES																	
	(KILOMETERS) X	(KILOMETERS) Y	CO	HC	NOX	PT	SO2	EXPECTED ASYMMETRIC MEAN												
401	13.01	8.24	2.240E-02	3.292E-02	6.211E-02	9.119E-01	1.202E-02													
402	10.52	8.66	4.969E-01	7.479E-01	3.470E-01	9.263E-01	1.377E-02													
403	10.62	8.42	5.421E-01	7.177E-01	2.969E-01	9.376E-01	1.273E-02													
404	10.48	8.37	6.245E-01	2.266E-01	5.355E-01	9.831E-01	3.490E-02													
405	11.55	8.36	5.003E-01	2.623E-01	2.630E-01	9.599E-01	4.651E-02													
406	11.24	8.35	6.299E-01	4.679E-01	5.802E-01	9.741E-01	2.076E-02													
407	11.34	8.32	9.763E-01	2.209E-01	7.747E-01	9.543E-01	2.016E-01													
408	11.20	8.26	7.737E-01	9.117E-01	7.400E-01	9.710E-01	1.092E-01													
409	12.05	8.36	5.381E-01	9.441E-01	5.795E-01	9.962E-01	4.631E-01													
410	12.52	7.31	2.110E-01	3.531E-01	4.215E-01	9.228E-01	1.081E-02													
411	12.56	7.50	2.999E-01	4.578E-01	5.768E-01	9.459E-01	2.989E-02													
412	12.86	7.40	2.239E-01	3.825E-01	4.686E-01	5.296E-01	2.391E-02													

1978 = AUG NAS MIRAMAR = 0900 TO 1000 HOURS ON A WEEKDAY

RECEPTOR CONCENTRATION DATA FROM AIRCRAFT SOURCES
 EXPECTED ARITHMETIC MEAN

RECEPTOR NUMBER	RECEPTOR LOCATION	(INILMETERS) X	Y	CD	HC	NOX	PT	SU2
401		10.01	3.24	4.900E-01	1.310E-01	4.350E-02	3.500E-01	5.285E-04
402		10.52	3.46	2.717E-01	8.303E-01	2.697E-00	1.451E-02	4.922E-01
403		10.07	3.92	2.160E-01	6.379E-00	1.700E-00	5.248E-01	1.339E-01
404		10.46	3.37	1.248E-02	2.715E-01	1.014E-01	3.078E-02	9.960E-01
405		11.50	3.36	7.189E-01	2.276E-01	5.179E-00	1.223E-02	3.005E-01
406		11.24	3.35	1.521E-02	5.542E-01	5.545E-00	1.351E-02	2.159E-01
407		11.34	3.32	5.351E-02	2.891E-02	2.980E-01	4.02E-02	1.867E-00
408		11.20	3.26	2.250E-02	1.127E-02	1.344E-01	2.557E-02	7.853E-01
409		12.07	3.36	1.734E-02	8.390E-01	2.891E-02	5.174E-02	2.079E-00
410		12.82	7.31	7.390E-00	2.530E-00	2.570E-00	8.818E-00	2.182E-02
411		12.37	7.50	1.020E-01	3.520E-00	3.500E-00	1.150E-01	3.044E-02
412		12.06	7.40	8.875E-00	3.075E-00	2.528E-00	1.001E-01	2.644E-02

1978 = AUG NAS MIRAMAR = 0900 TO 1000 HOURS ON A WEEKDAY

RECEPTOR CONCENTRATION DATA FROM AIRCRAFT SOURCES
 FRACTION OF TOTAL

RECEPTOR NUMBER	RECEPTOR LOCATION	(INILMETERS) X	Y	CD	HC	NOX	PT	SU2
401		10.01	3.24	2.351E-03	7.017E-03	6.850E-03	1.120E-01	1.301E-04
402		10.52	3.46	2.431E-01	3.647E-01	2.944E-01	6.411E-01	9.603E-02
403		10.07	3.92	2.050E-01	4.031E-01	2.002E-01	9.501E-01	3.187E-02
404		10.46	3.37	2.500E-01	6.549E-01	6.132E-01	7.921E-01	1.979E-01
405		11.50	3.36	4.022E-01	1.196E-01	4.435E-01	9.751E-01	1.513E-02
406		11.24	3.35	6.490E-01	7.542E-01	5.932E-01	5.801E-01	3.869E-01
407		11.34	3.32	4.032E-01	9.315E-01	8.238E-01	5.558E-01	3.319E-01
408		11.20	3.26	7.312E-01	8.205E-01	7.331E-01	9.390E-01	1.637E-01
409		12.07	3.36	3.207E-01	4.103E-01	5.701E-01	7.947E-01	3.570E-01
410		12.82	7.31	8.145E-02	2.771E-01	2.877E-01	7.843E-01	2.304E-03
411		12.37	7.50	1.105E-01	1.579E-01	3.554E-01	8.141E-01	2.503E-03
412		12.06	7.40	9.687E-02	1.159E-01	3.100E-01	7.947E-01	6.674E-03

WIND = 4JG GAS MIRAMAR PERIOD = 0900 TO 1000 HOURS ON A WEEKDAY

RECEPTOR CONCENTRATION DATA FROM AIRCRAFT SOURCES
EXPECTED ARITHMETIC MEAN

RECEPTOR NUMBER	RECEPTOR LOCATION	(KILOMETERS)	X	Y	CO	HC	NOX	PT	SC2
401		10.01	8.24		2.942E-02	9.353E-01	3.097E-01	1.785E-01	5.628E-02
402		10.52	8.46		1.592E-02	1.203E-00	2.379E-02	1.170E-01	2.971E-03
403		10.62	8.42		4.503E-02	9.619E-01	4.514E-01	4.350E-01	2.587E-03
404		10.48	8.37		1.357E-01	2.574E-00	1.021E-01	3.006E-01	7.507E-02
405		10.56	8.36		5.418E-01	2.892E-01	2.845E-01	8.381E-01	2.465E-01
406		11.24	8.35		3.507E-02	1.523E-00	2.554E-01	5.455E-01	1.273E-02
407		11.34	8.32		7.105E-01	3.201E-01	4.660E-00	3.769E-01	1.069E-02
408		11.20	8.26		5.100E-01	2.151E-01	2.719E-00	3.331E-01	2.282E-02
409		12.05	8.26		1.692E-03	7.583E-02	2.247E-02	1.182E-03	4.230E-00
410		12.82	7.31		4.083E-01	1.233E-01	3.870E-01	3.359E-01	9.372E-02
411		12.56	7.50		3.430E-01	1.197E-01	6.346E-00	2.872E-01	7.545E-02
412		12.86	7.40		4.816E-01	1.831E-01	4.634E-01	2.850E-01	1.106E-01

WIND = 4JG GAS MIRAMAR PERIOD = 0900 TO 1000 HOURS ON A WEEKDAY

RECEPTOR CONCENTRATION DATA FROM AIRCRAFT SOURCES
FRACTION OF TOTAL

RECEPTOR NUMBER	RECEPTOR LOCATION	(KILOMETERS)	X	Y	CO	HC	NOX	PT	SC2
401		10.01	8.24		0.240E-02	1.055E-01	8.480E-02	9.348E-01	3.166E-02
402		10.52	8.46		3.072E-02	1.181E-01	3.009E-02	4.425E-01	1.491E-03
403		10.62	8.42		6.403E-02	1.034E-01	7.203E-02	7.651E-01	1.549E-03
404		10.48	8.37		2.192E-01	3.131E-01	4.112E-01	5.348E-01	3.471E-02
405		10.56	8.36		5.263E-01	7.119E-01	4.372E-01	9.341E-01	1.147E-01
406		11.24	8.35		9.503E-02	1.331E-01	5.779E-02	7.522E-01	9.023E-03
407		11.34	8.32		5.589E-01	7.674E-01	5.197E-01	9.251E-01	4.097E-03
408		11.20	8.26		4.863E-01	6.602E-01	3.579E-01	9.478E-01	9.273E-03
409		12.05	8.26		0.602E-01	3.197E-01	5.780E-01	5.982E-01	5.072E-01
410		12.82	7.31		2.935E-01	5.614E-01	5.237E-01	5.357E-01	2.865E-02
411		12.56	7.50		3.057E-01	3.093E-01	2.822E-01	5.367E-01	2.578E-02
412		12.86	7.40		4.272E-01	3.974E-01	5.473E-01	9.298E-01	3.376E-02

APPENDIX B

CO AND PT CONCENTRATION PROFILES FROM AIRCRAFT SOURCES
(SENSITIVITY STUDY)

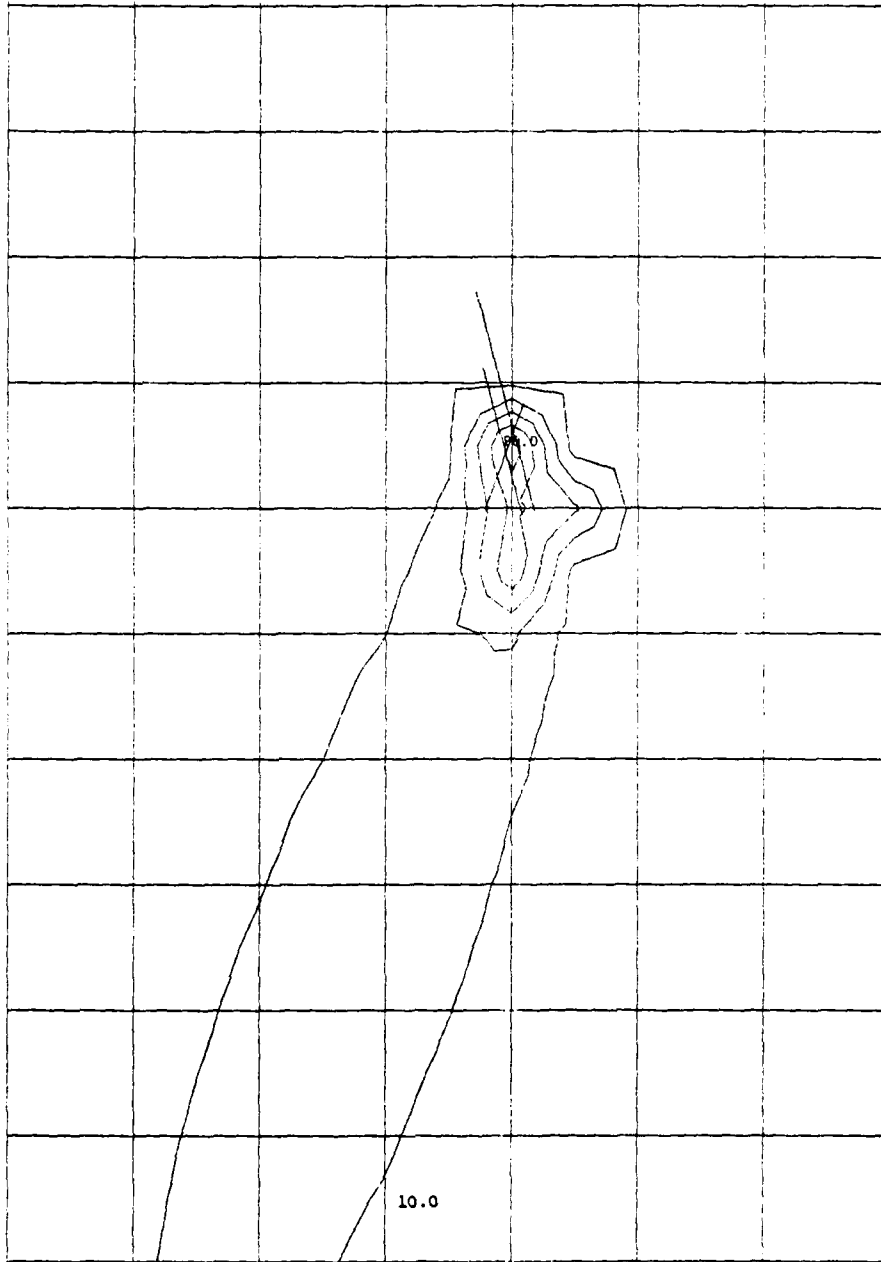

AIRCRAFT CO CONCENTRATION PROFILE (RUN NO. 1)
(Scale = 20 $\mu\text{g}/\text{m}^3$ per contour)

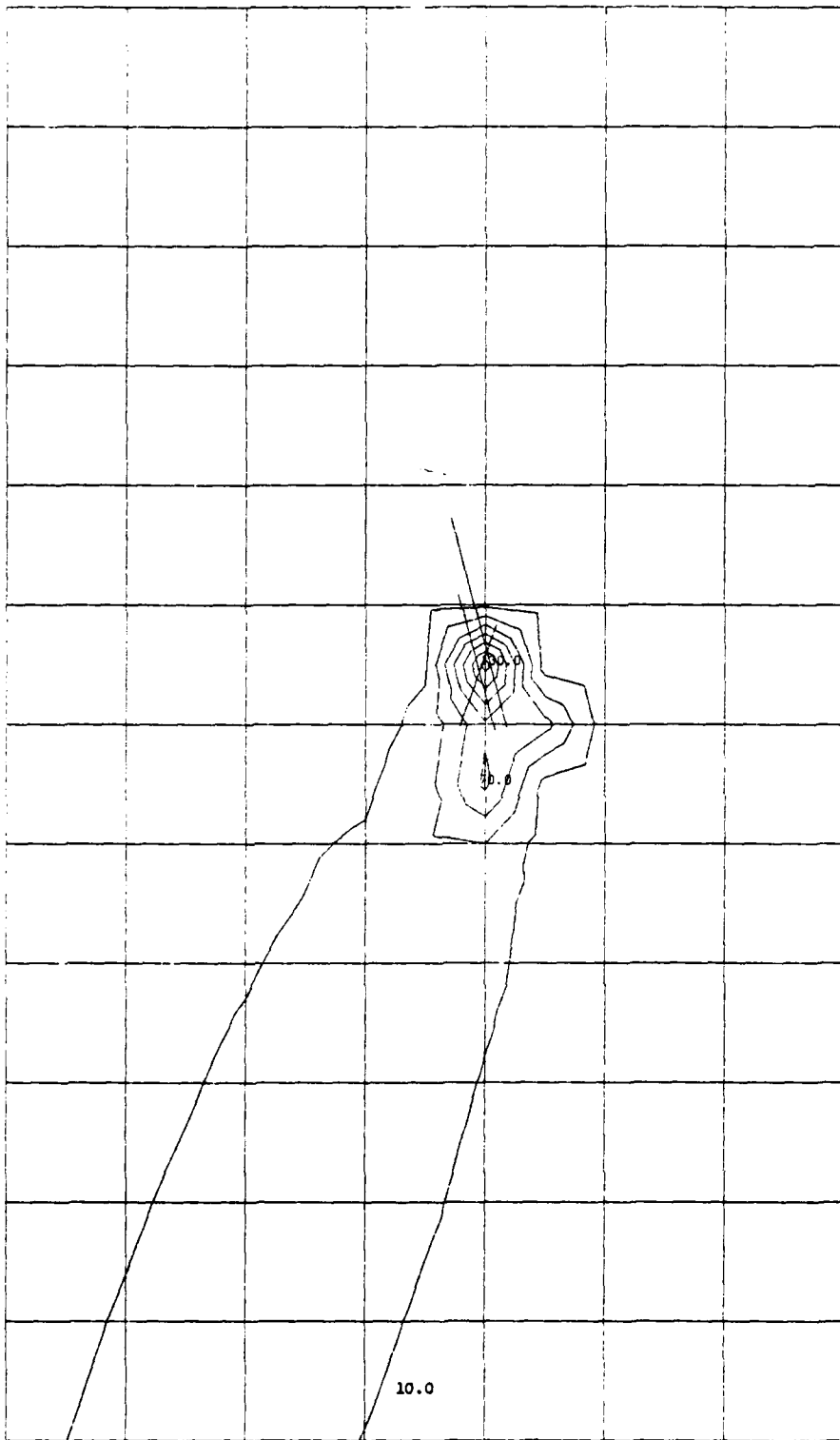

AIRCRAFT PT CONCENTRATION PROFILE (RUN NO. 1)
(Scale = 20 $\mu\text{gm}/\text{m}^3$ per contour)

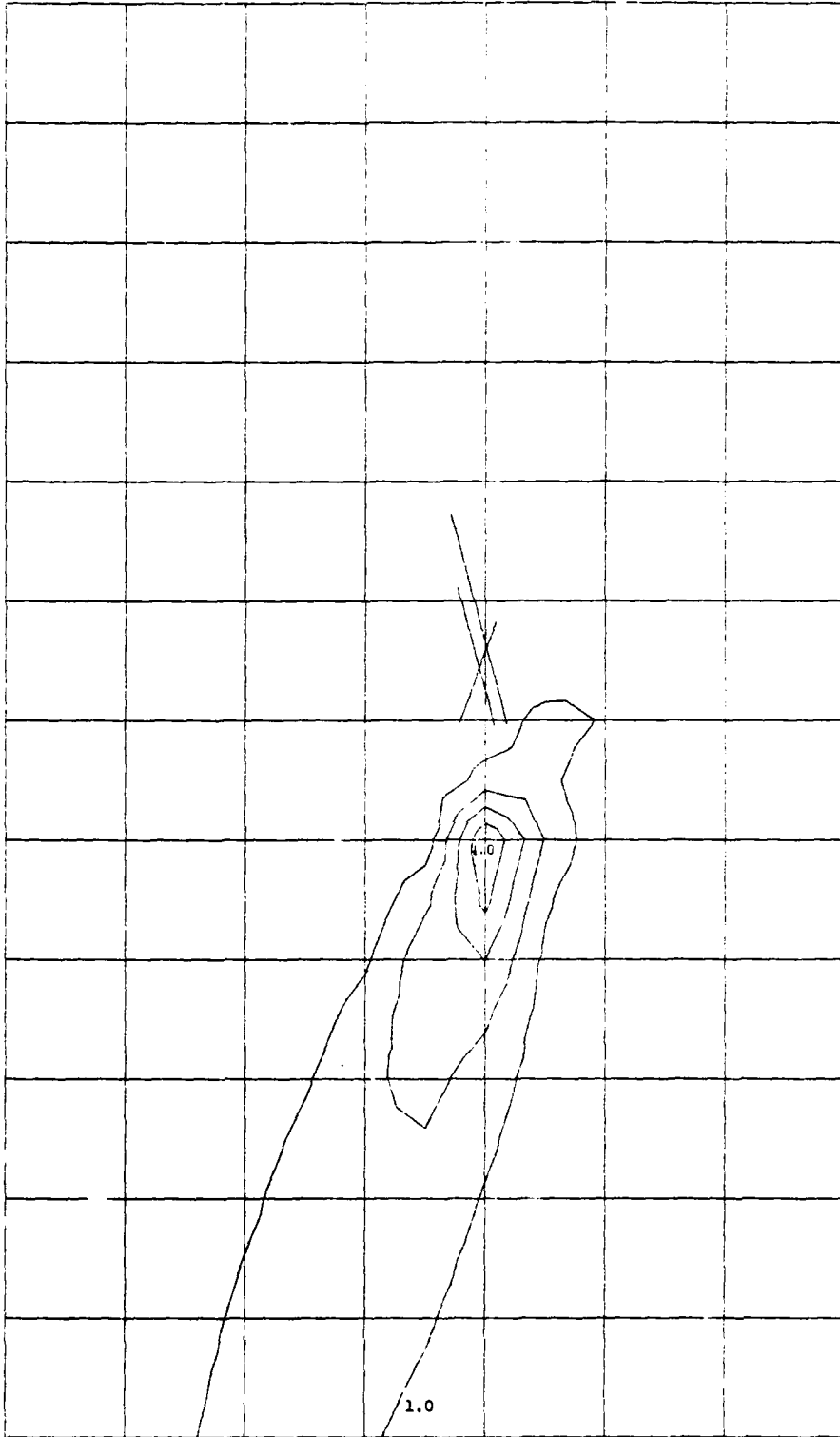

AIRBASE CO CONCENTRATION PROFILE (RUN NO. 1)
(Scale = $1 \mu\text{gm}/\text{m}^3$ per contour)

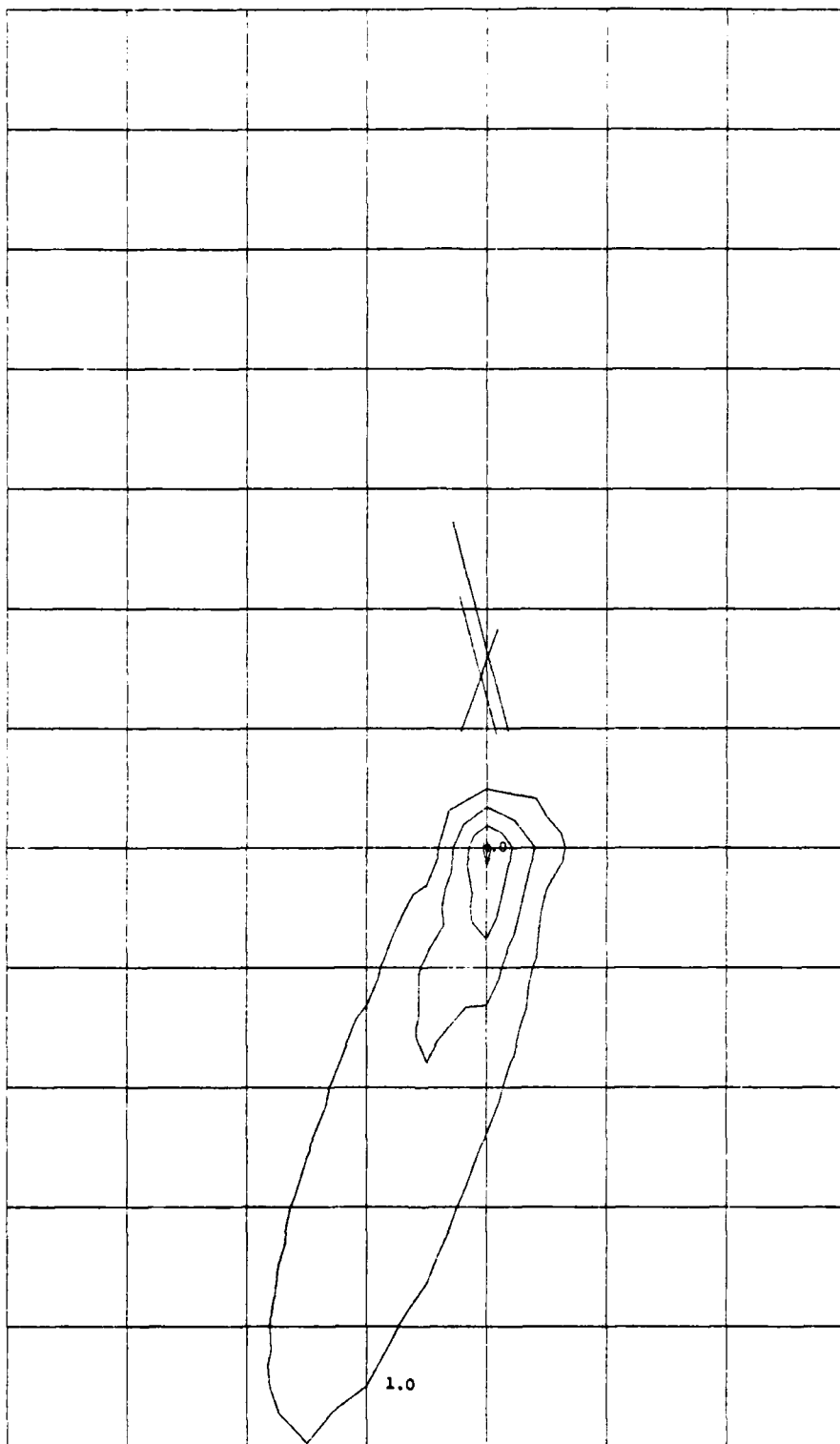

AIRBASE PT CONCENTRATION PROFILE (RUN NO. 1)
(Scale = 1 $\mu\text{gm}/\text{m}^3$ per contour)

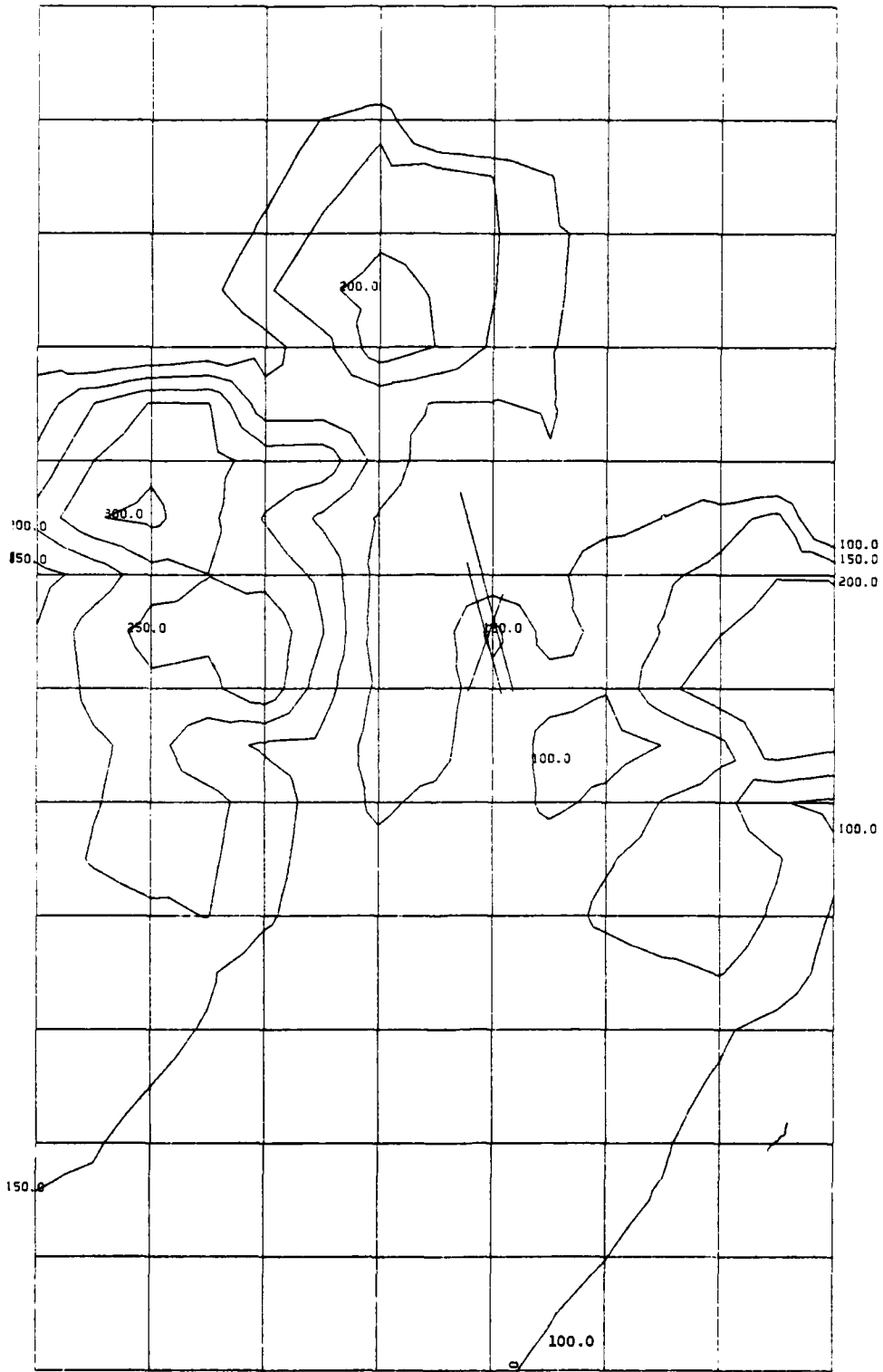

TOTAL CO CONCENTRATION PROFILE (RUN NO. 1)
(Scale = $50 \mu\text{g}/\text{m}^3$ per contour)

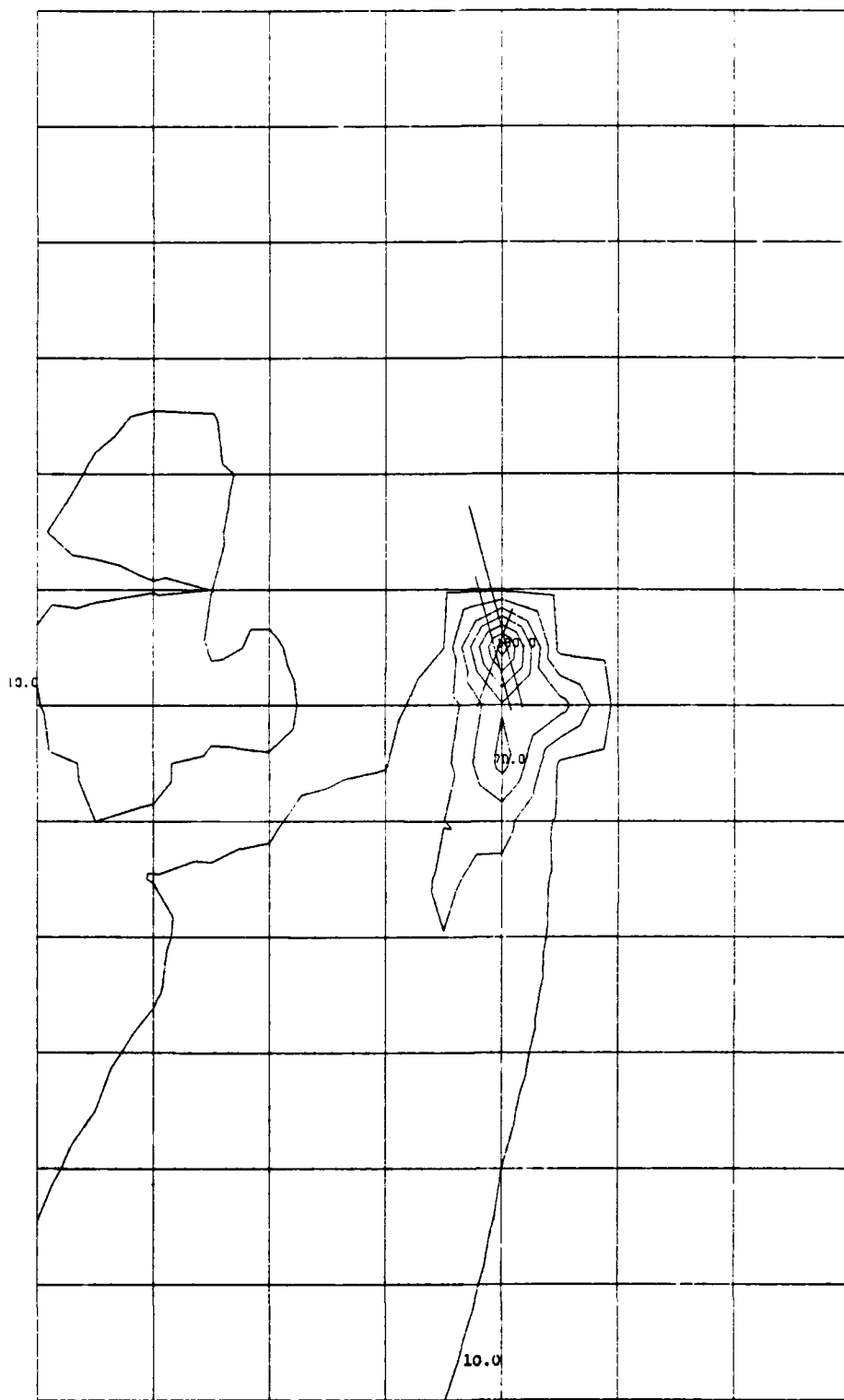

TOTAL PT CONCENTRATION PROFILE (RUN NO. 1)
(Scale = 20 $\mu\text{gm}/\text{m}^3$ per contour)

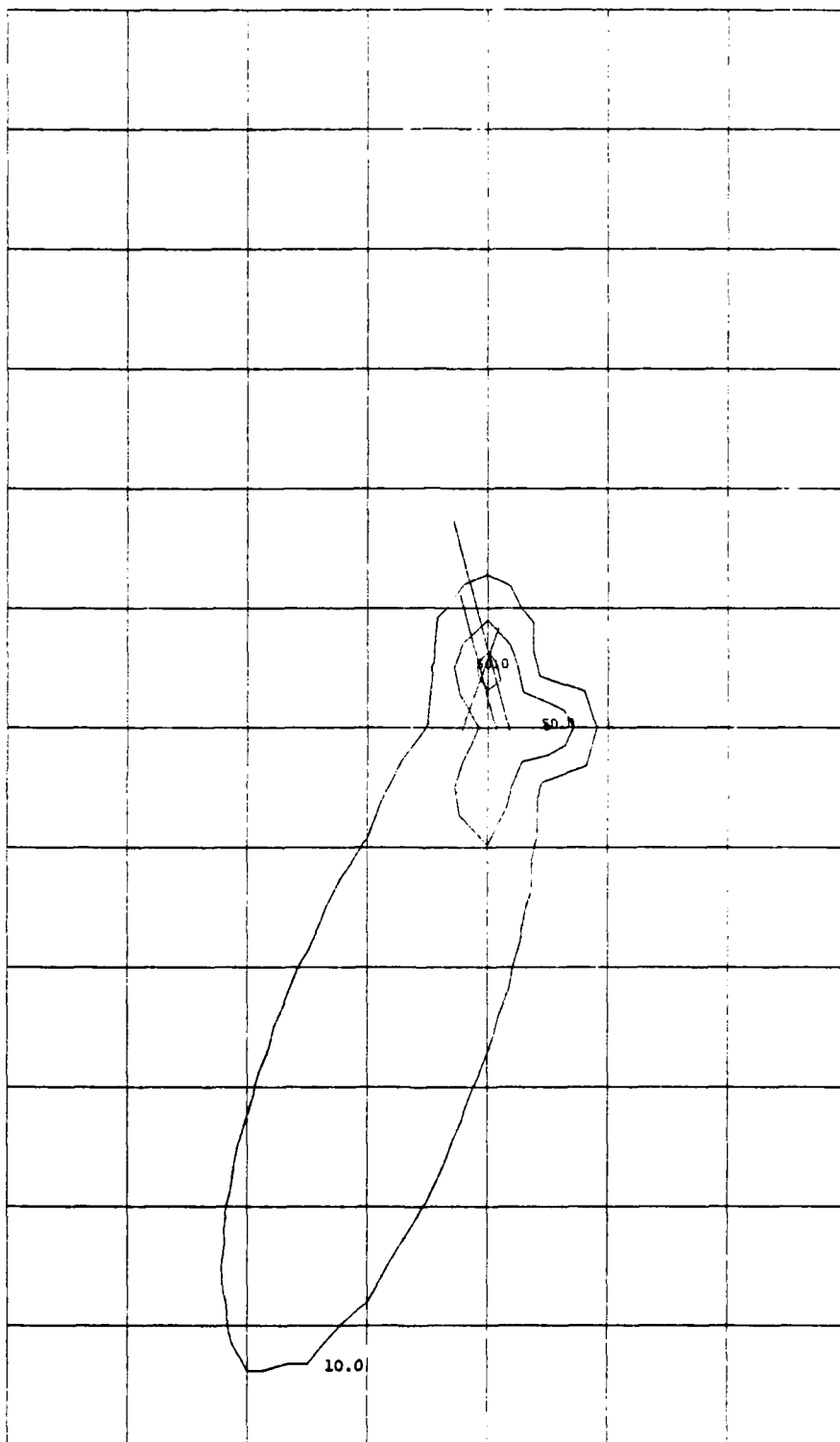

AIRCRAFT CO CONCENTRATION PROFILE (RUN NO. 2)

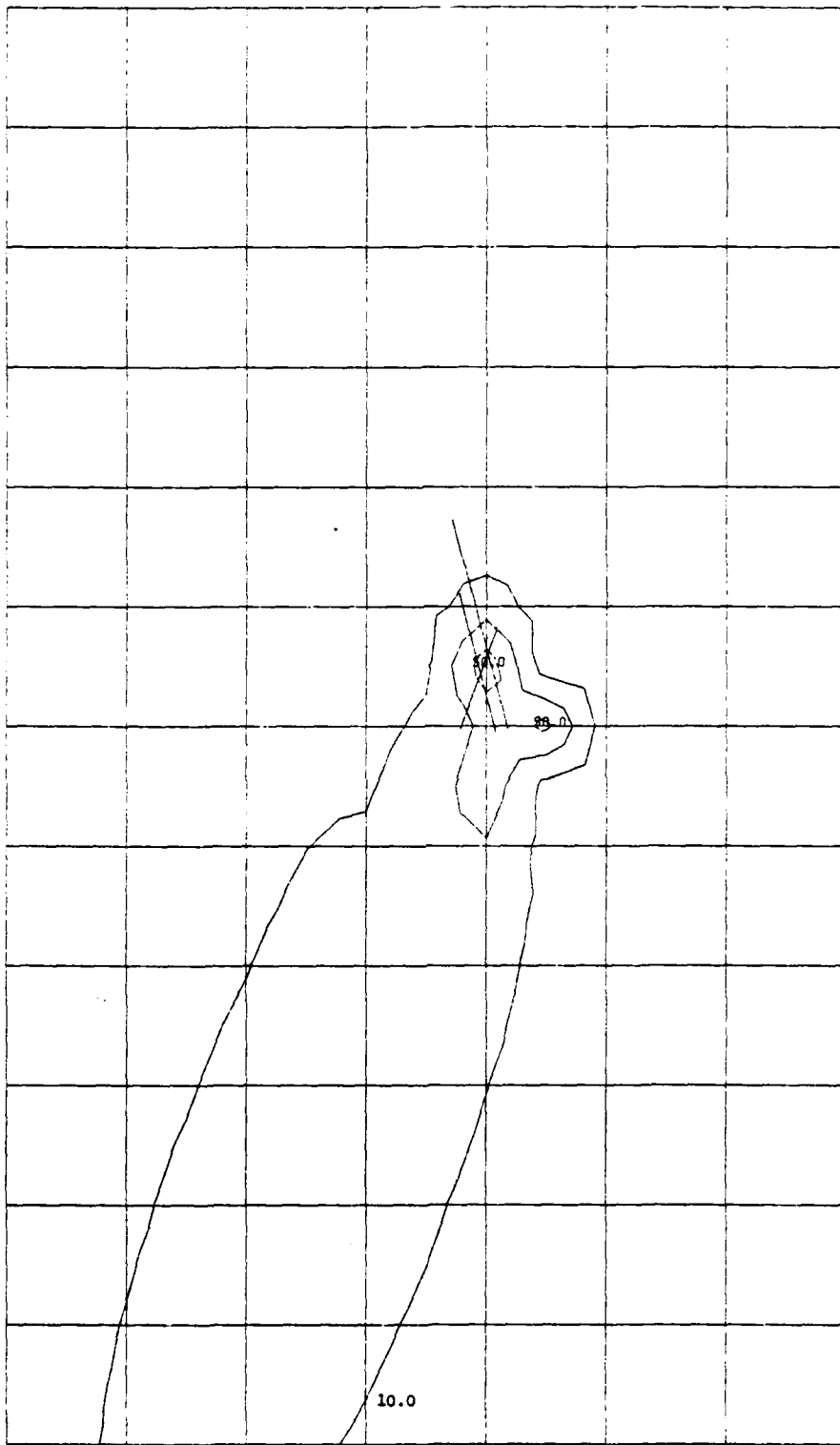

AIRCRAFT PT CONCENTRATION PROFILE (RUN NO. 2)

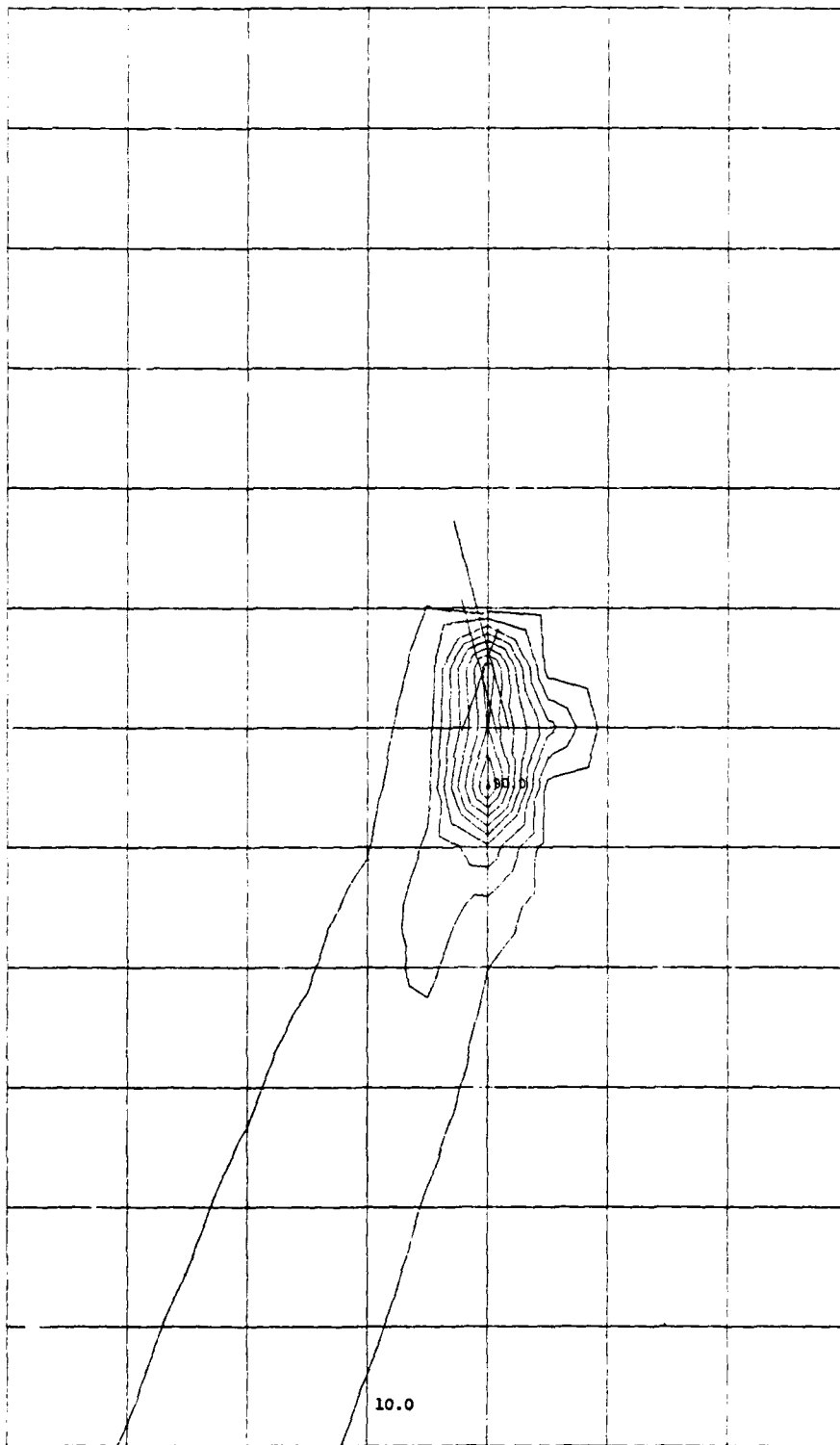

AIRCRAFT CO CONCENTRATION PROFILE (RUN NO. 3)

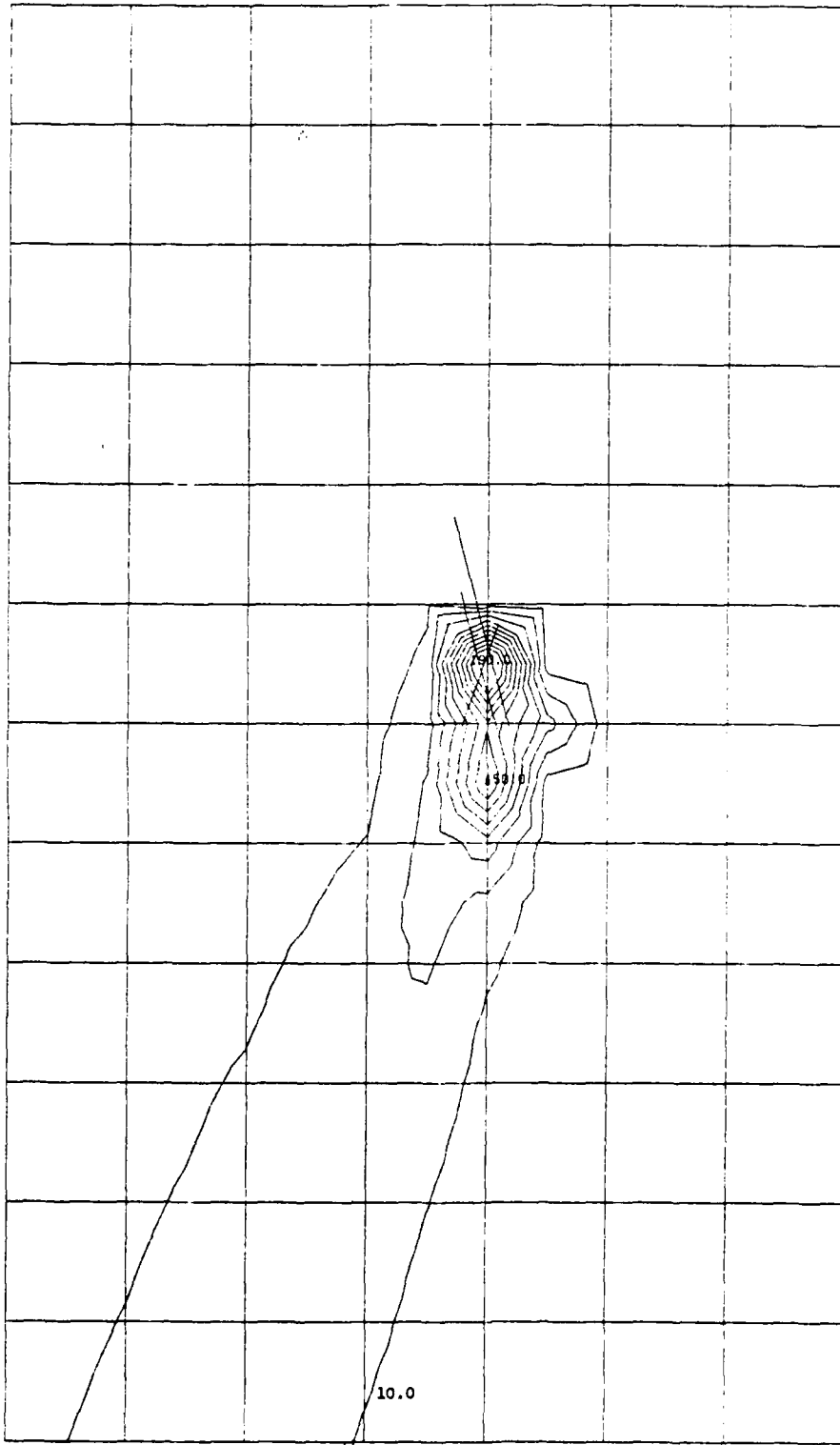

AIRCRAFT PT CONCENTRATION PROFILE (RUN NO. 3)

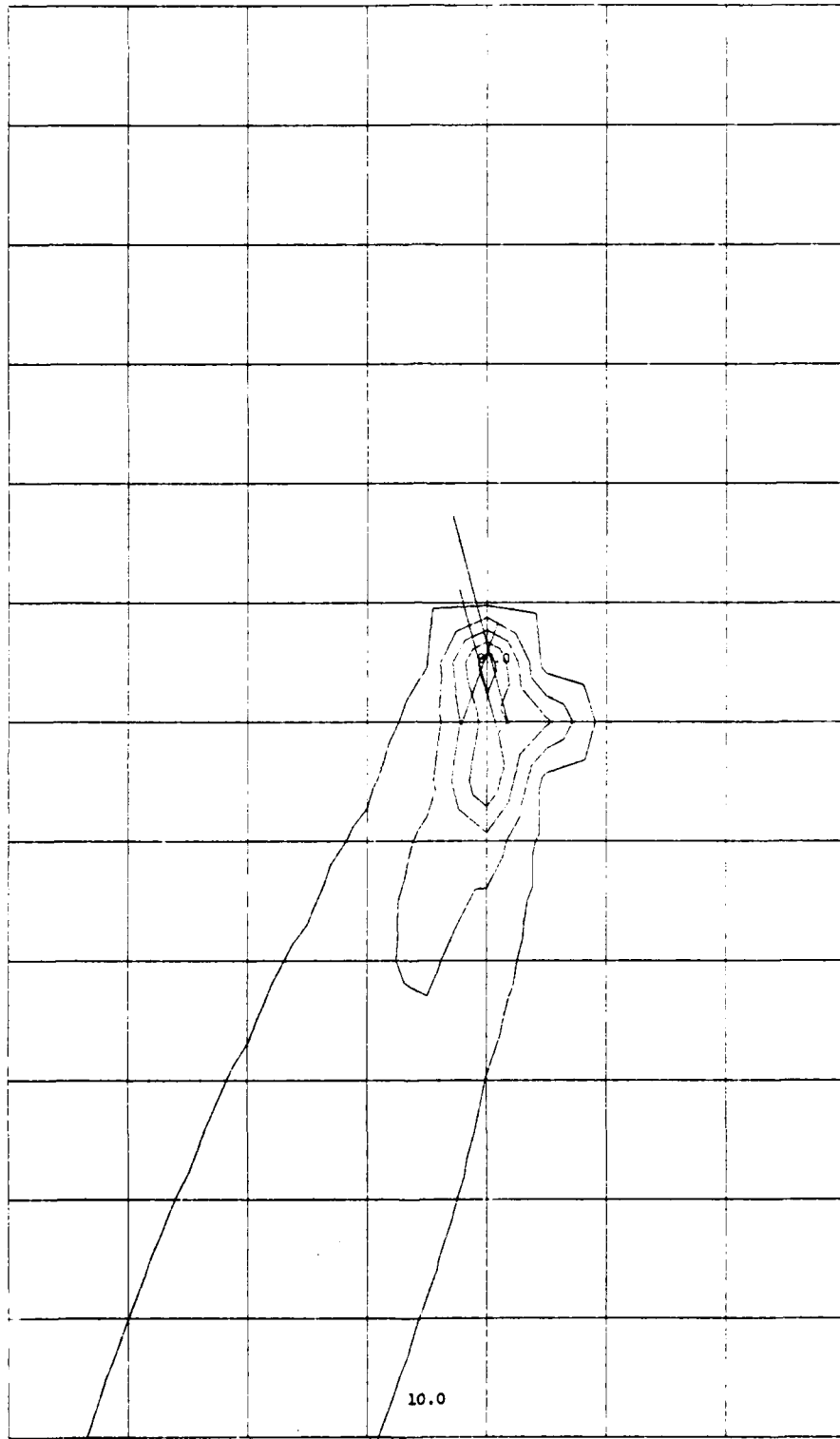

AIRCRAFT CO CONCENTRATION PROFILE (RUN NO. 4)

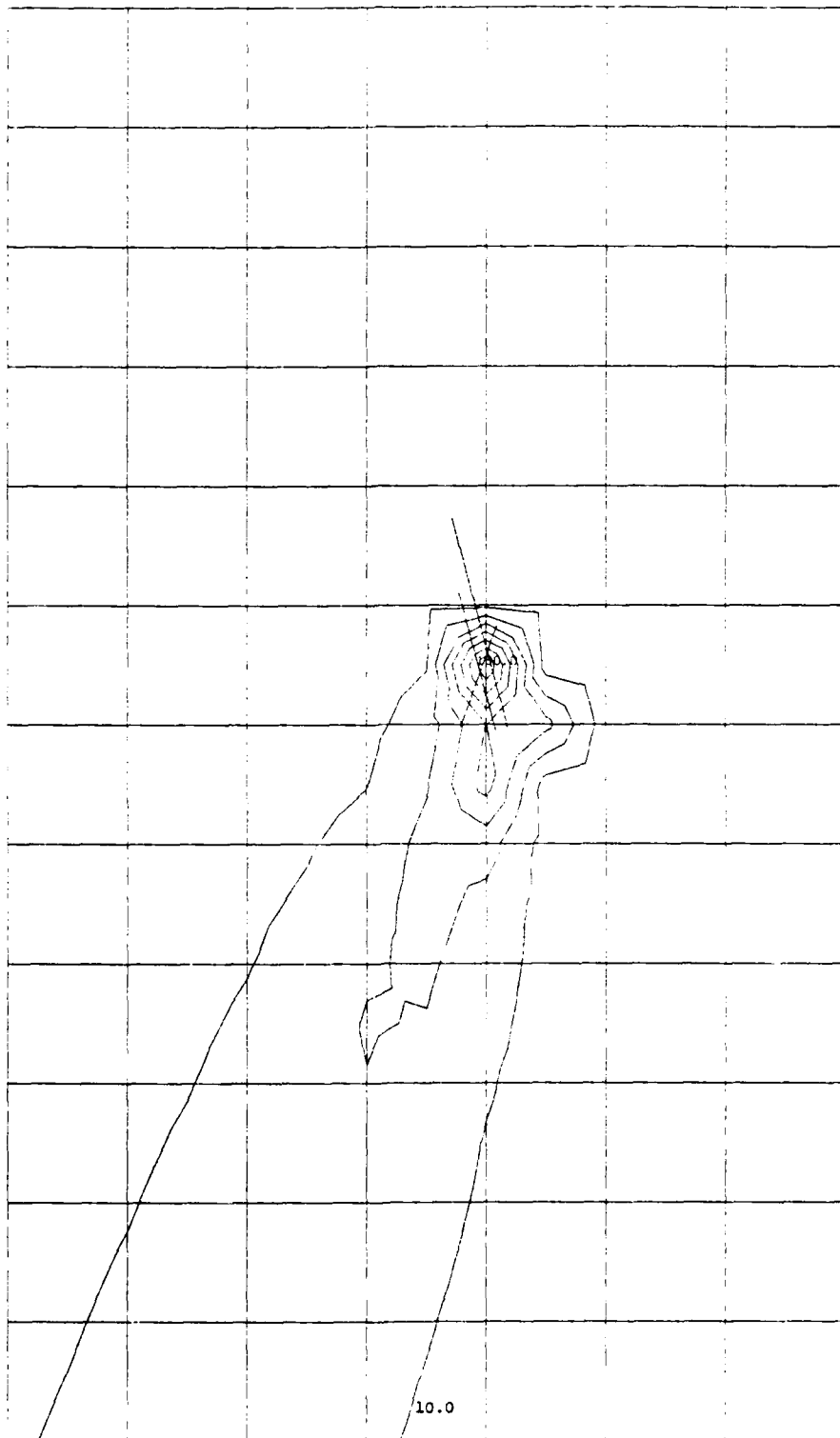

AIRCRAFT PT CONCENTRATION PROFILE (RUN NO. 4)

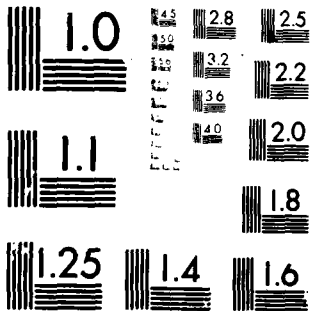

MICROCOPY RESOLUTION TEST CHART
NATIONAL BUREAU OF STANDARDS-1963-A

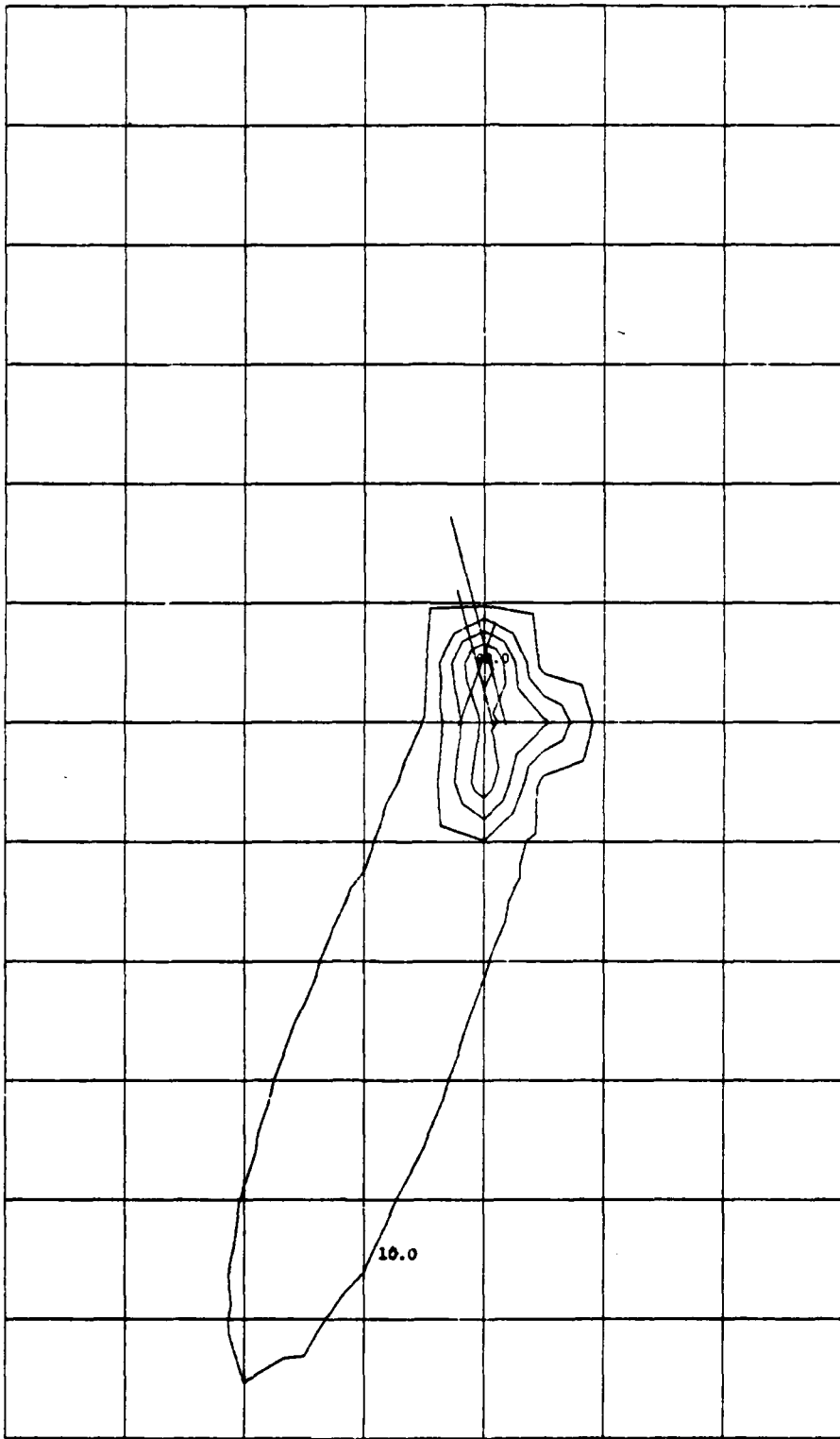

AIRCRAFT CO CONCENTRATION PROFILE (RUN NO. 5)

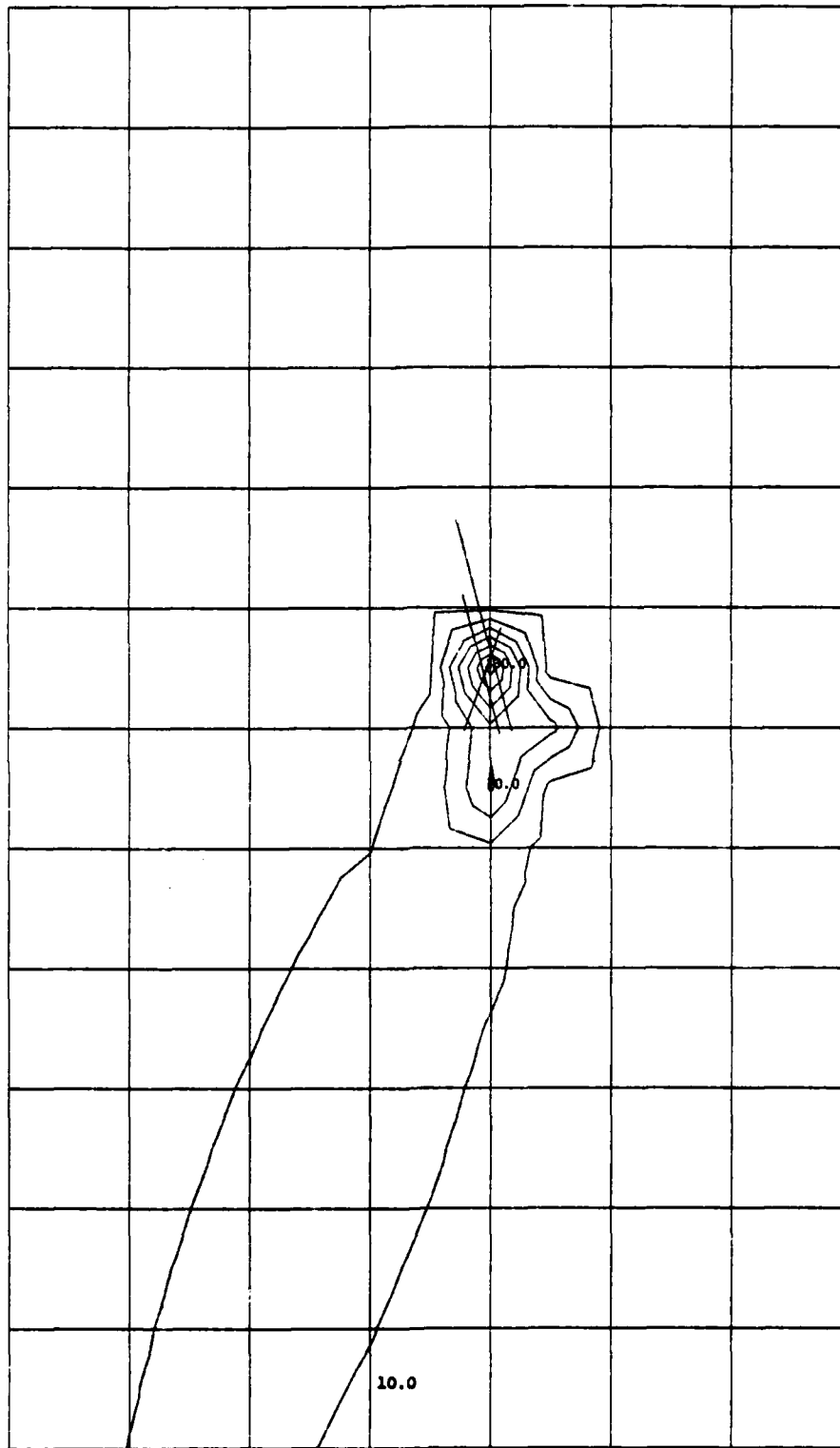

AIRCRAFT PT CONCENTRATION PROFILE (RUN NO. 5)

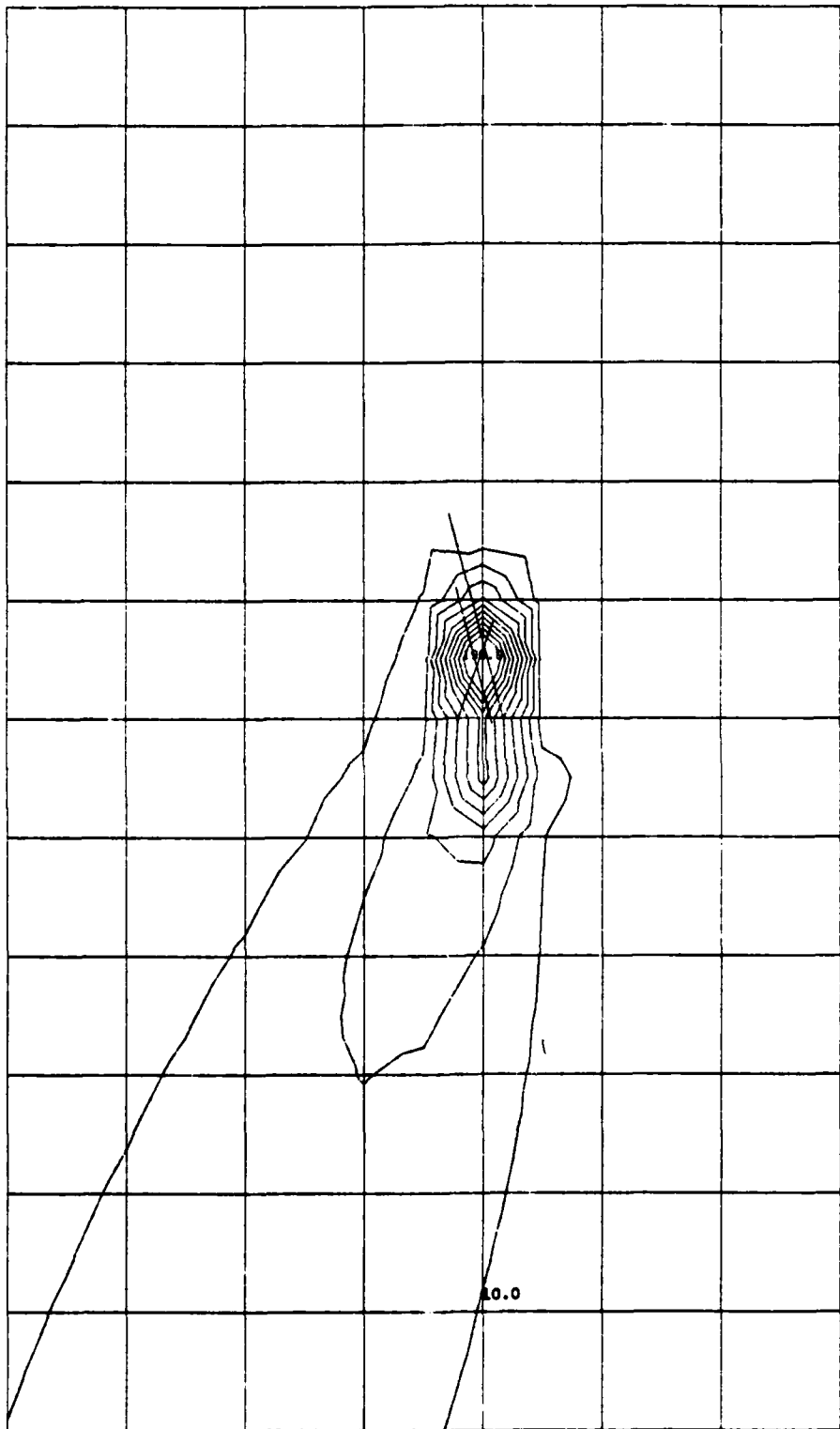

AIRCRAFT CO CONCENTRATION PROFILE (RUN NO. 6)

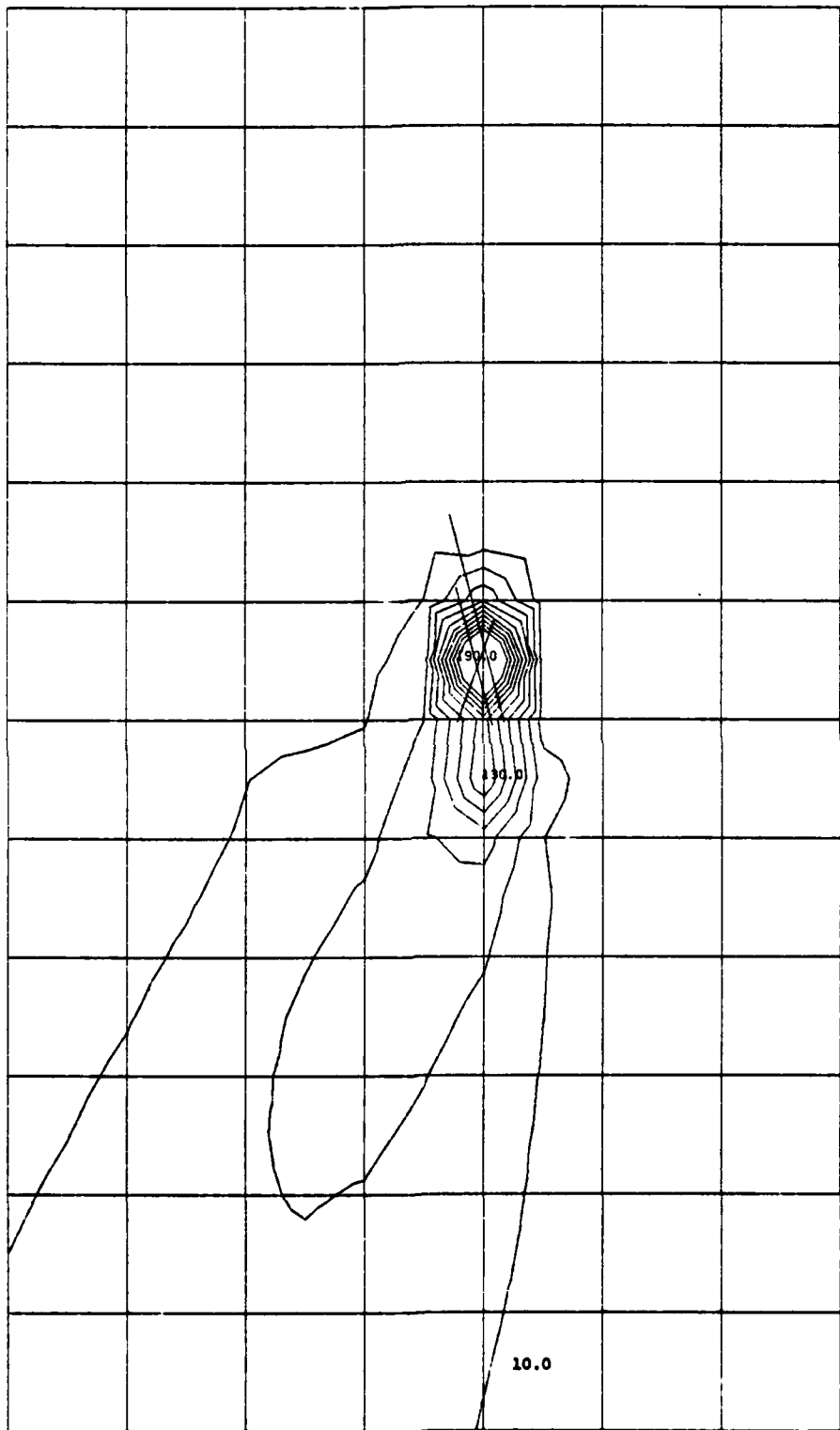

AIRCRAFT PT CONCENTRATION PROFILE (RUN NO. 6)

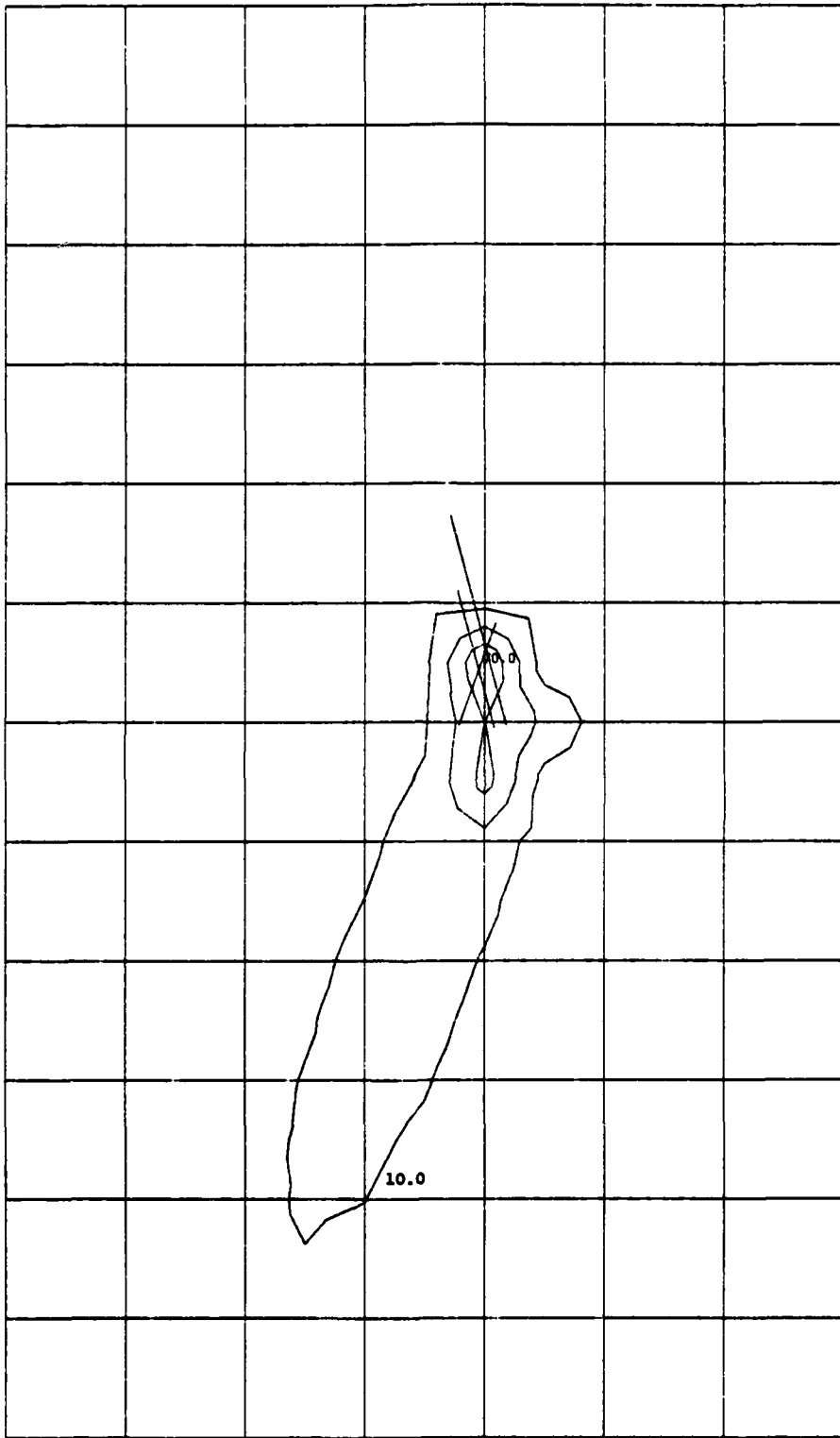

AIRCRAFT CO CONCENTRATION PROFILE (RUN NO. 7)

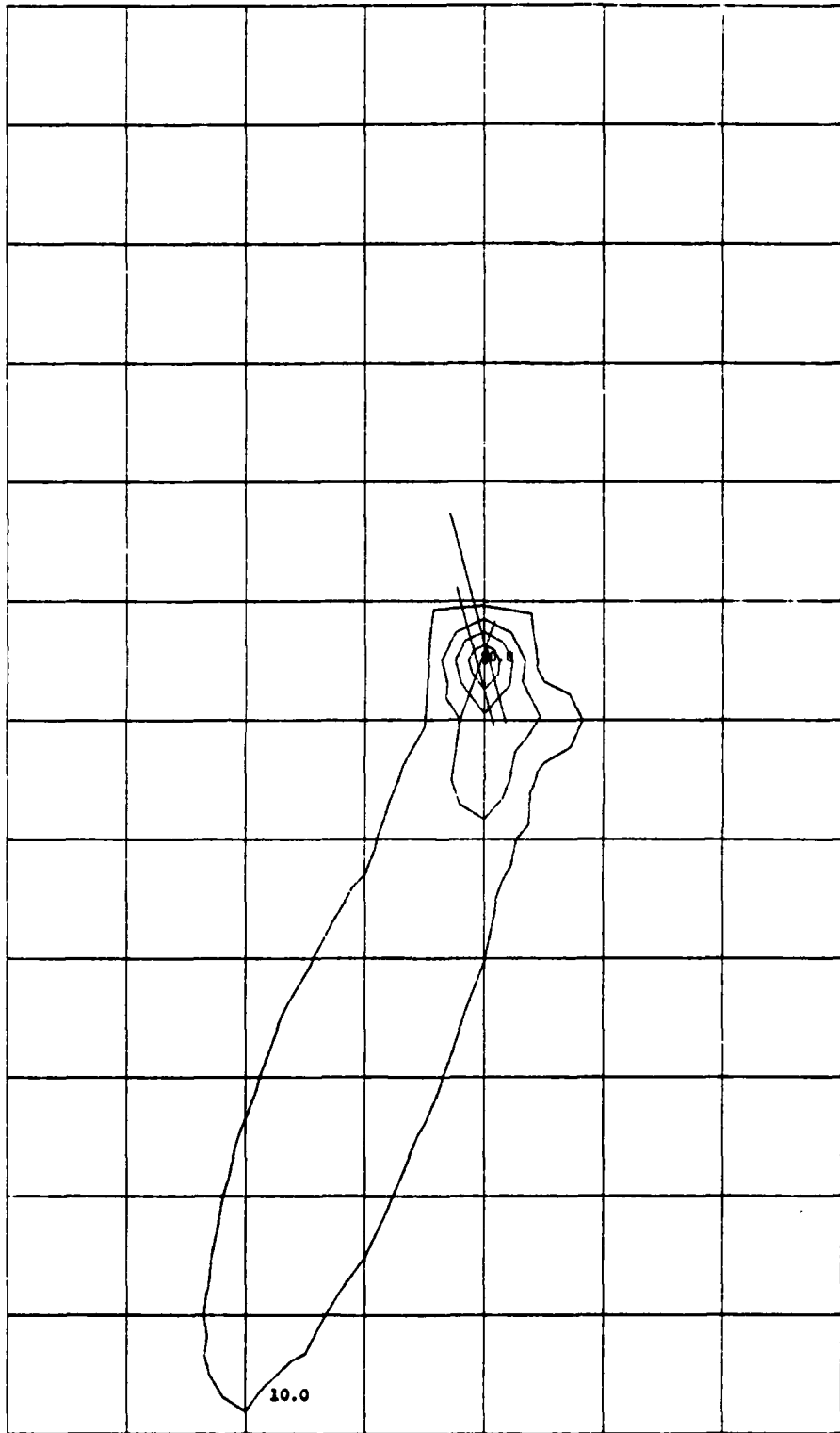

AIRCRAFT PT CONCENTRATION PROFILE (RUN NO. 7)

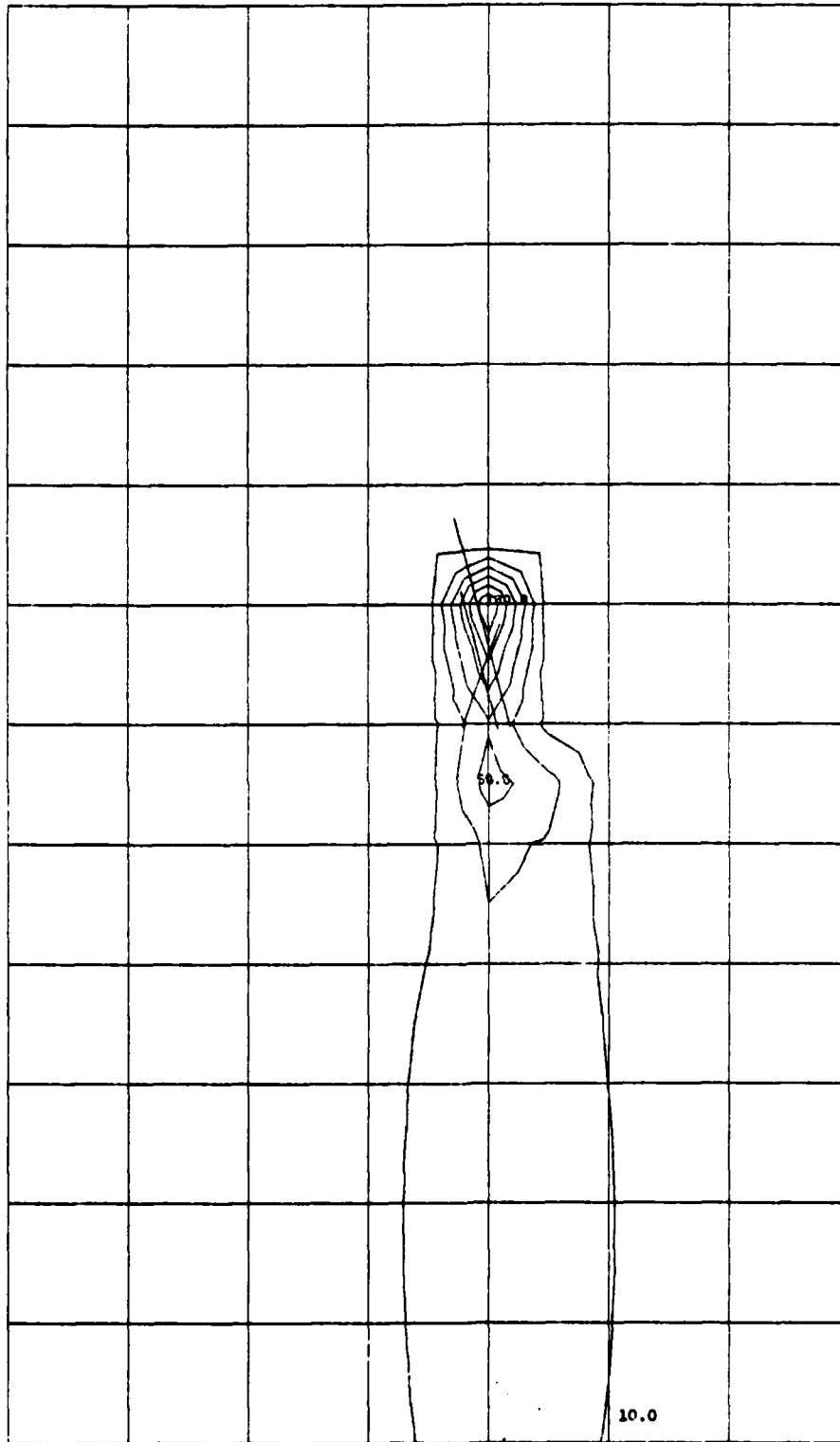

AIRCRAFT CO CONCENTRATION PROFILE (RUN NO. 8)

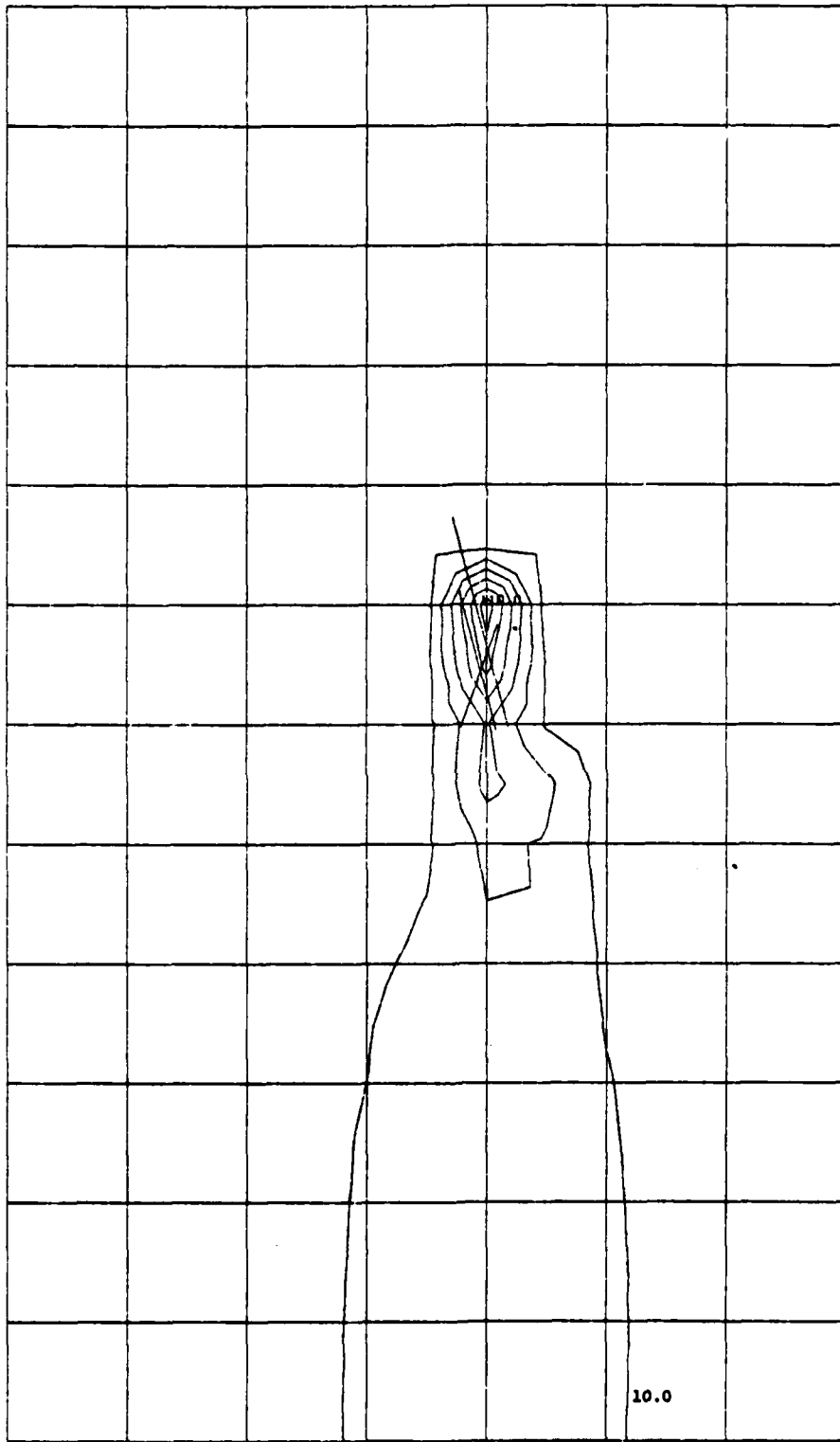

AIRCRAFT PT CONCENTRATION PROFILE (RUN NO. 8)

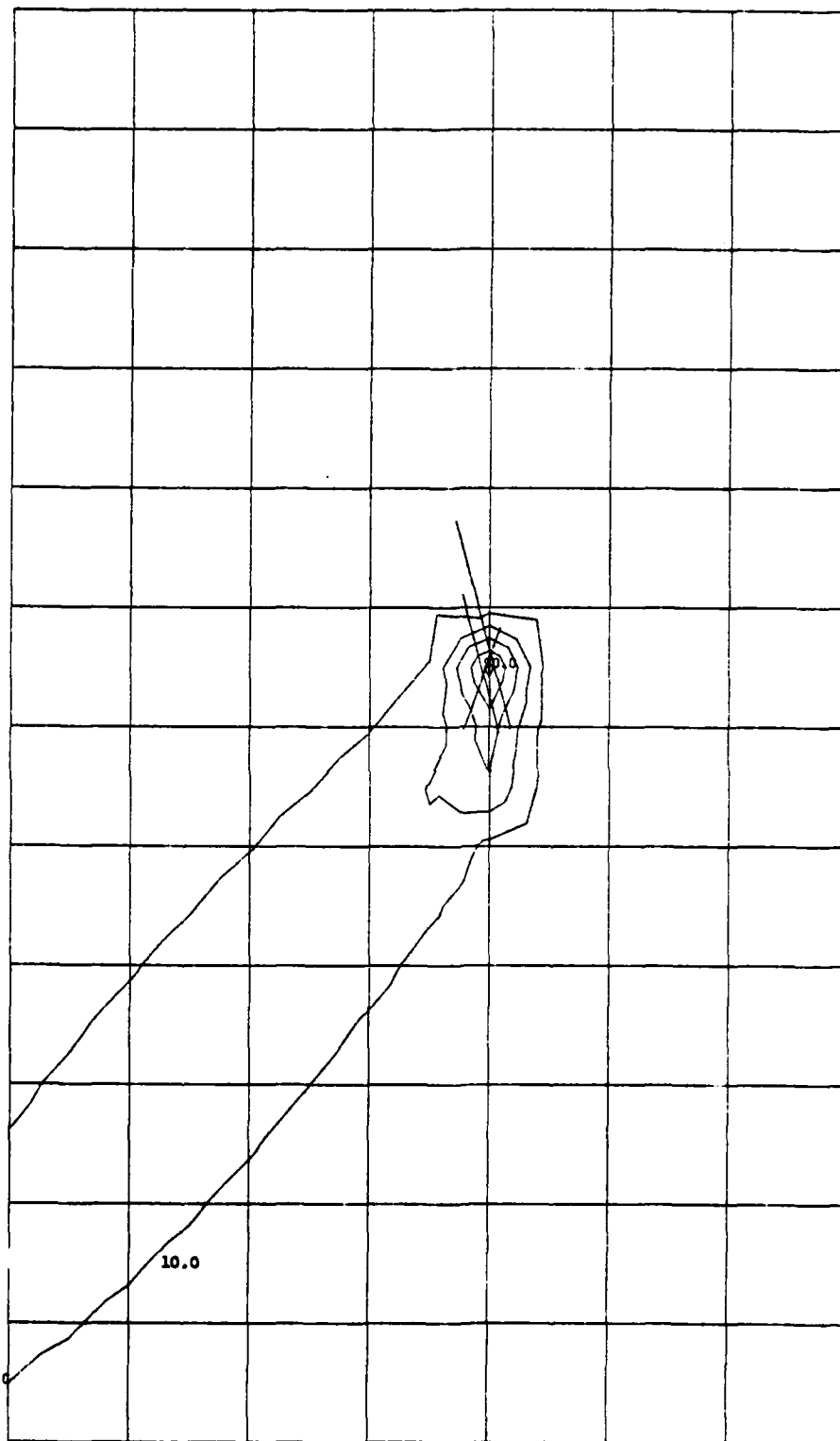

AIRCRAFT CO CONCENTRATION PROFILE (RUN NO. 9)

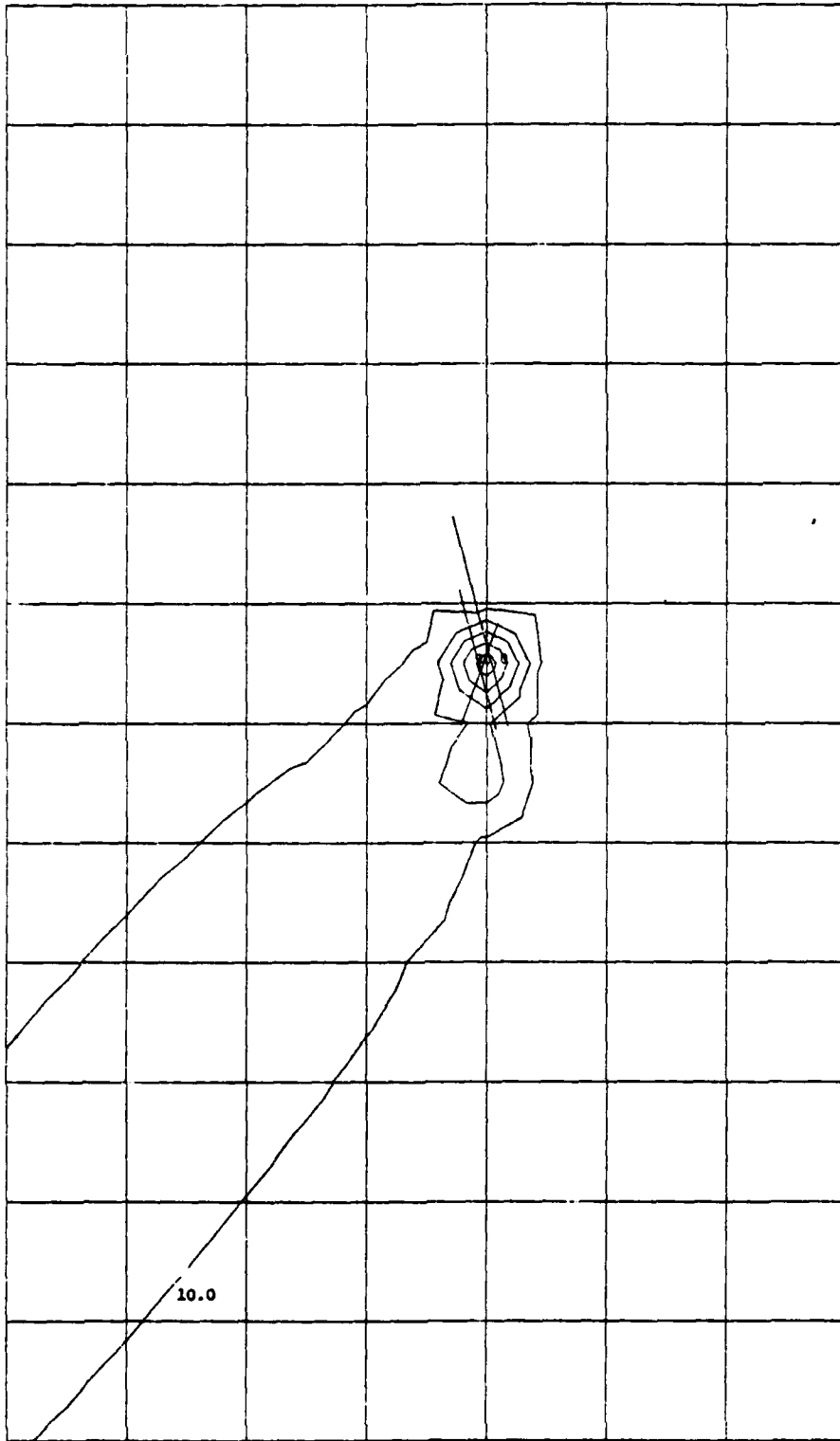

AIRCRAFT PT CONCENTRATION PROFILE (RUN NO. 9)

APPENDIX C
CO AND PT CONCENTRATION PROFILES FROM AIRCRAFT SOURCES
(INTENSIVE STUDY)

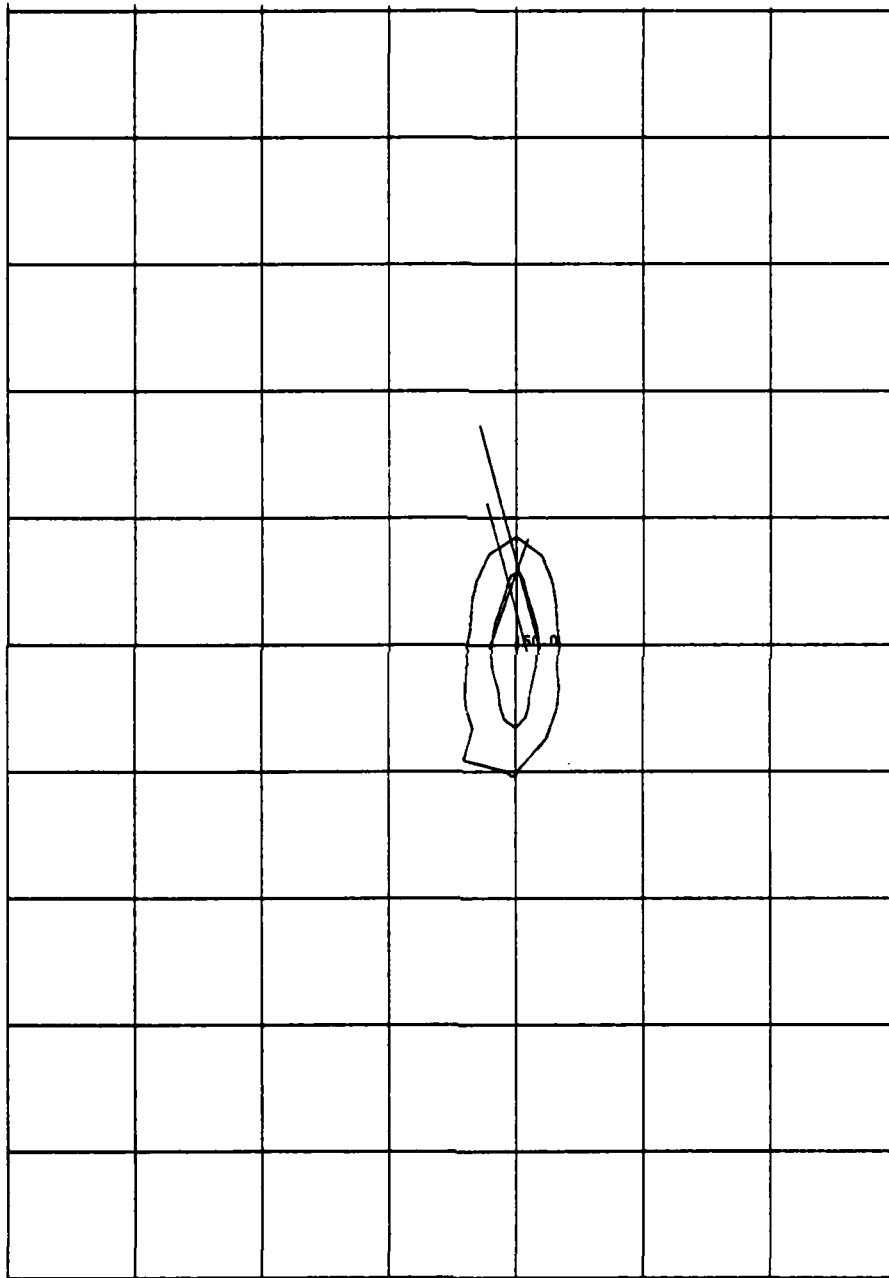

AIRCRAFT CO CONCENTRATION PROFILE (1 AUG 1300-1400)
INCREMENTED FROM 50.0
(Scale = $50 \mu\text{gm}/\text{m}^3$ per contour)

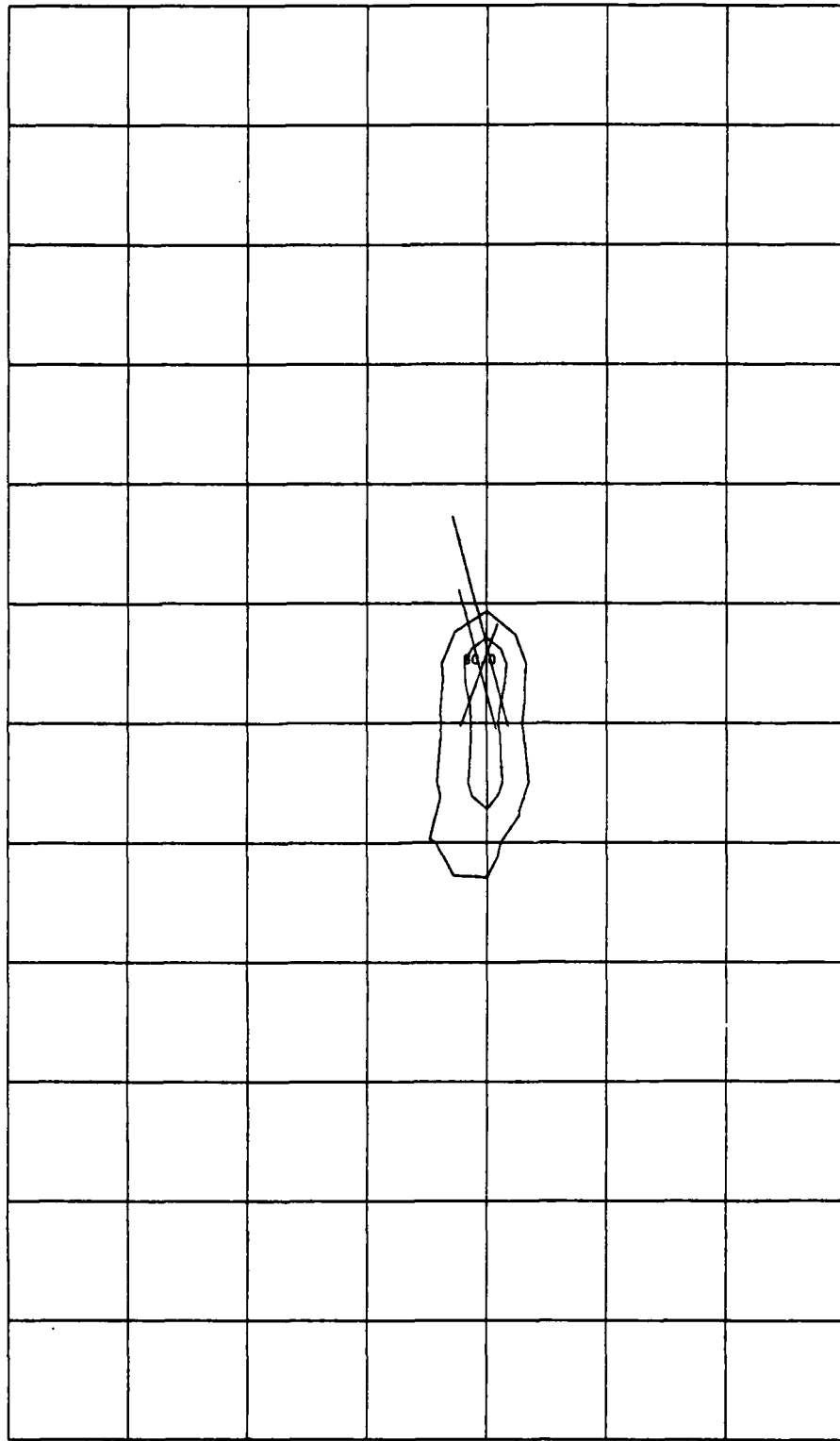

AIRCRAFT PT CONCENTRATION PROFILE (1 AUG 1300-1400)
INCREMENTED FROM 30.0
(Scale = 30 $\mu\text{gm}/\text{m}^3$ per contour)

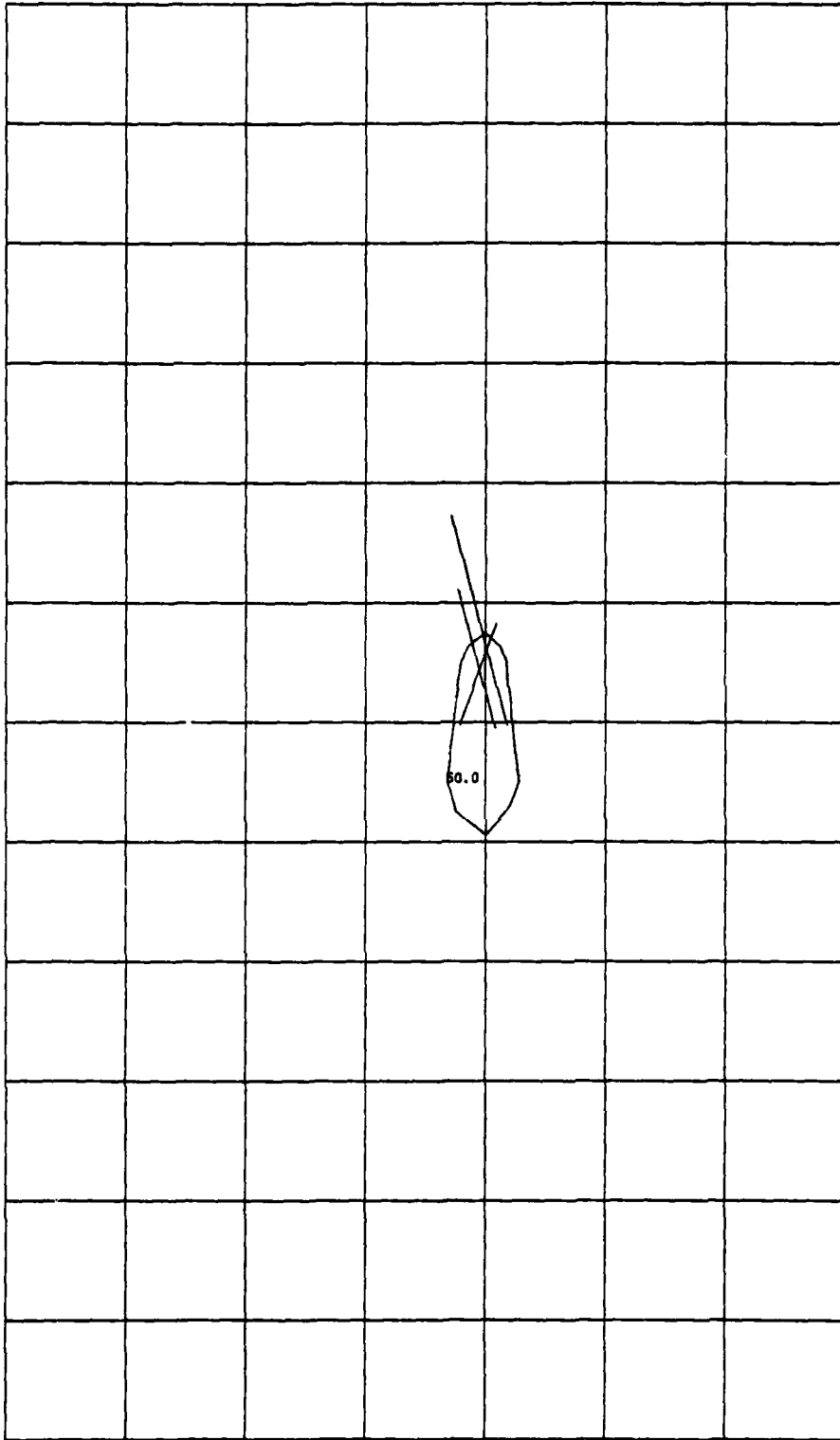

AIRCRAFT CO CONCENTRATION PROFILE (1 AUG 1400-1500)
INCREMENTED FROM 50.0

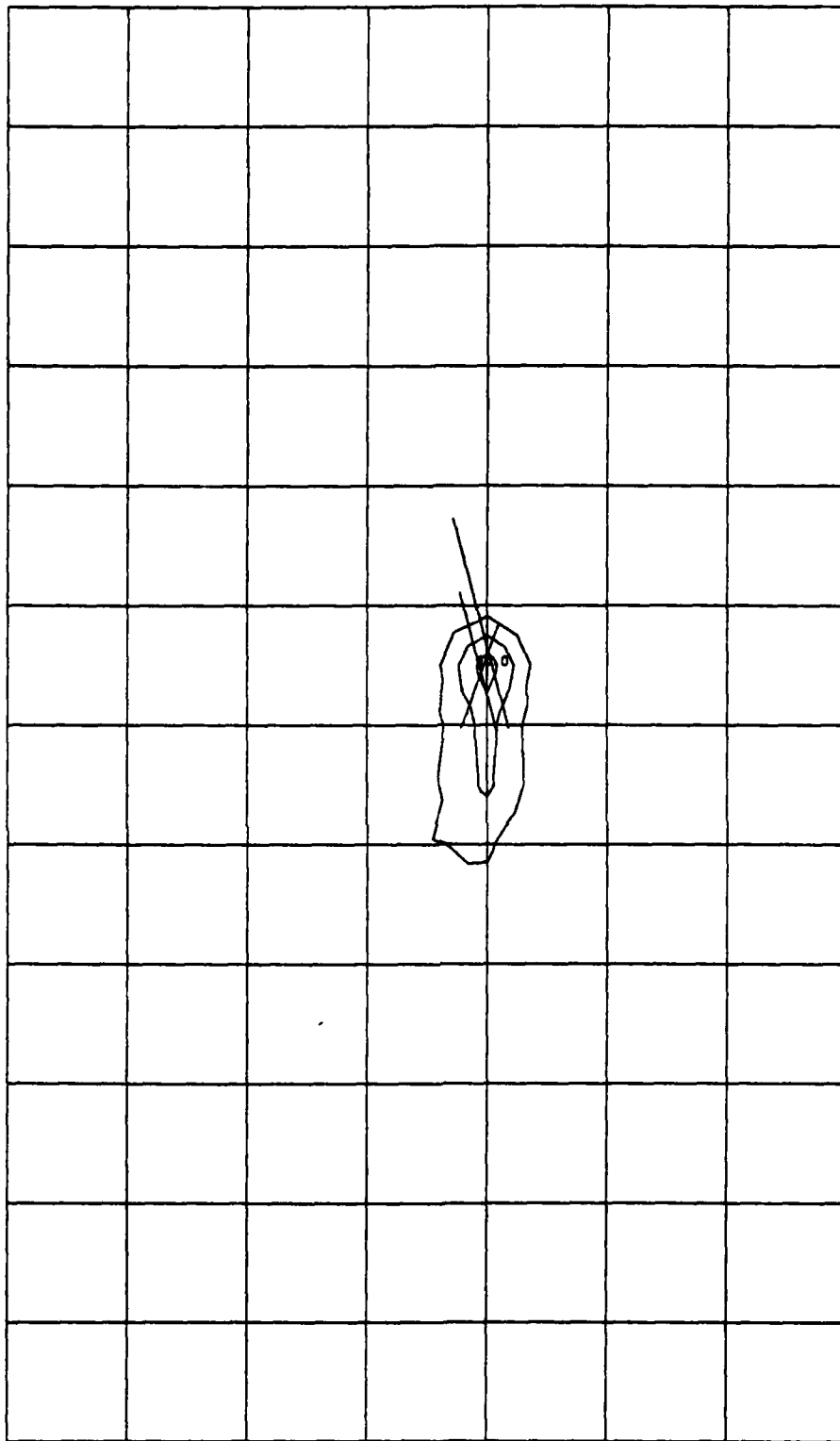

AIRCRAFT PT CONCENTRATION PROFILE (1 AUG 1400-1500)
INCREMENTED FROM 30.0

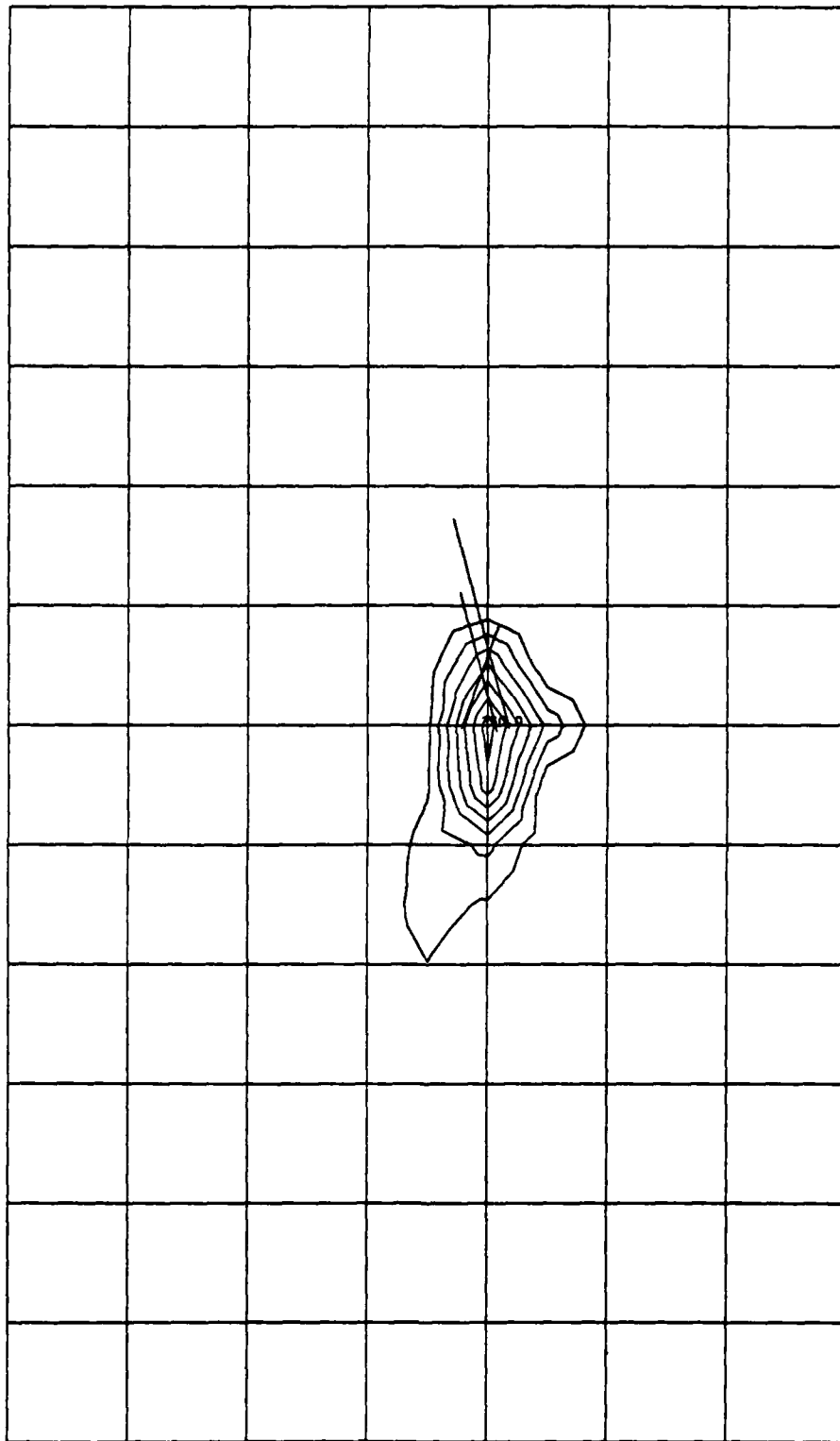

AIRCRAFT CO CONCENTRATION PROFILE (2 AUG 1400-1500)
INCREMENTED FROM 50.0

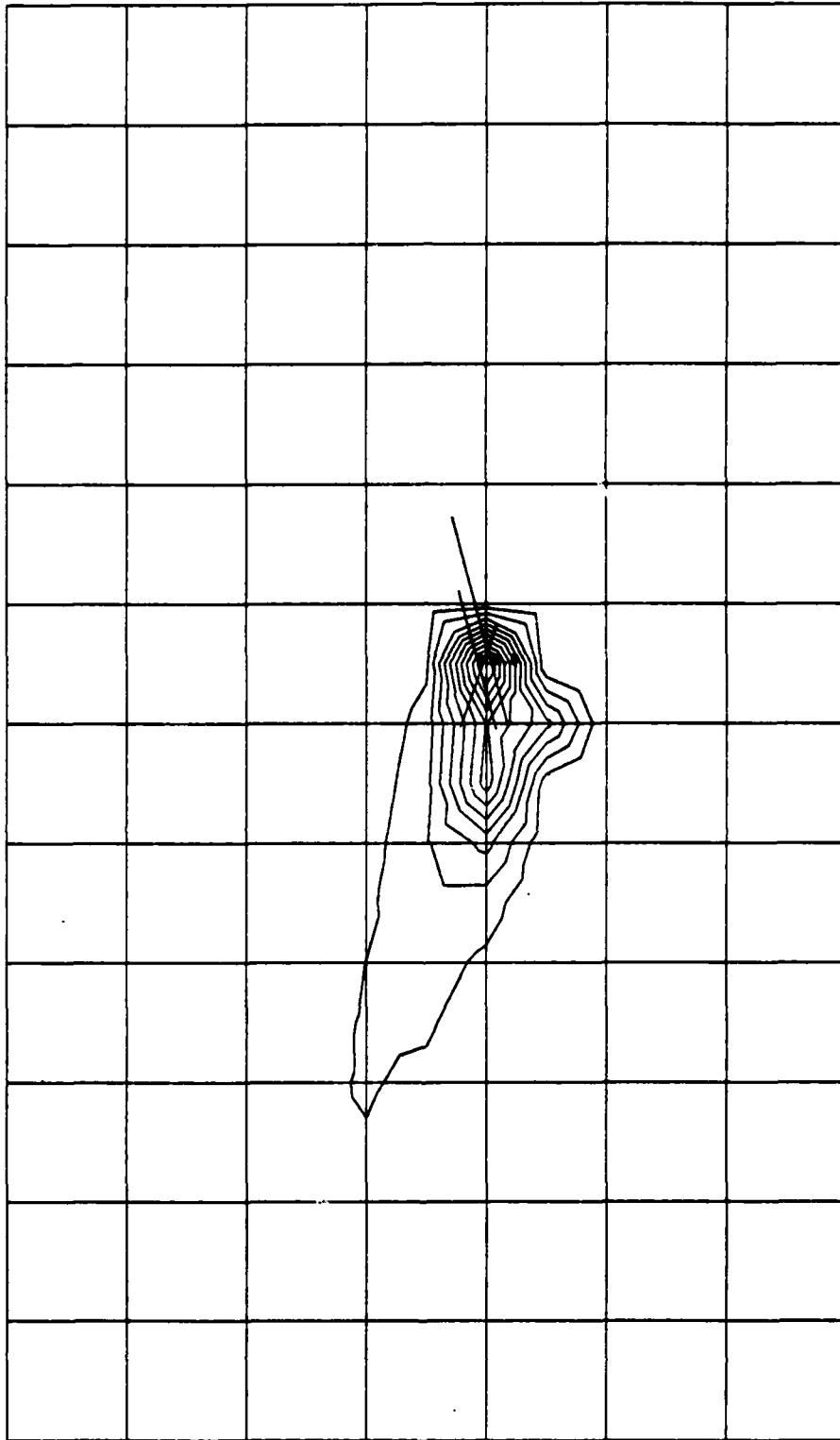

AIRCRAFT PT CONCENTRATION PROFILE (2 AUG 1400-1500)
INCREMENTED FROM 30.0

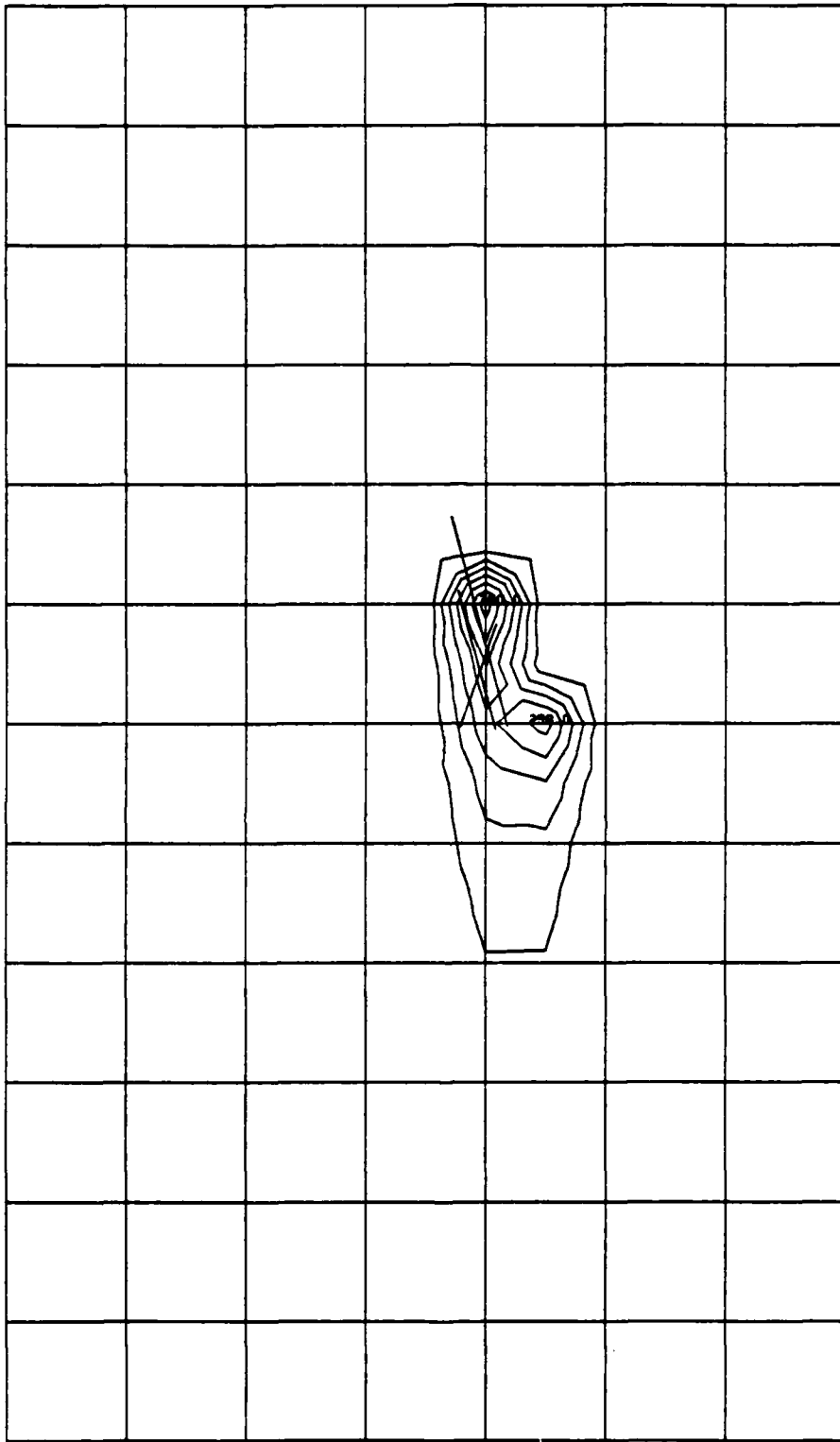

AIRCRAFT CO CONCENTRATION PROFILE (2 AUG 1500-1600)
INCREMENTED FROM 50.0

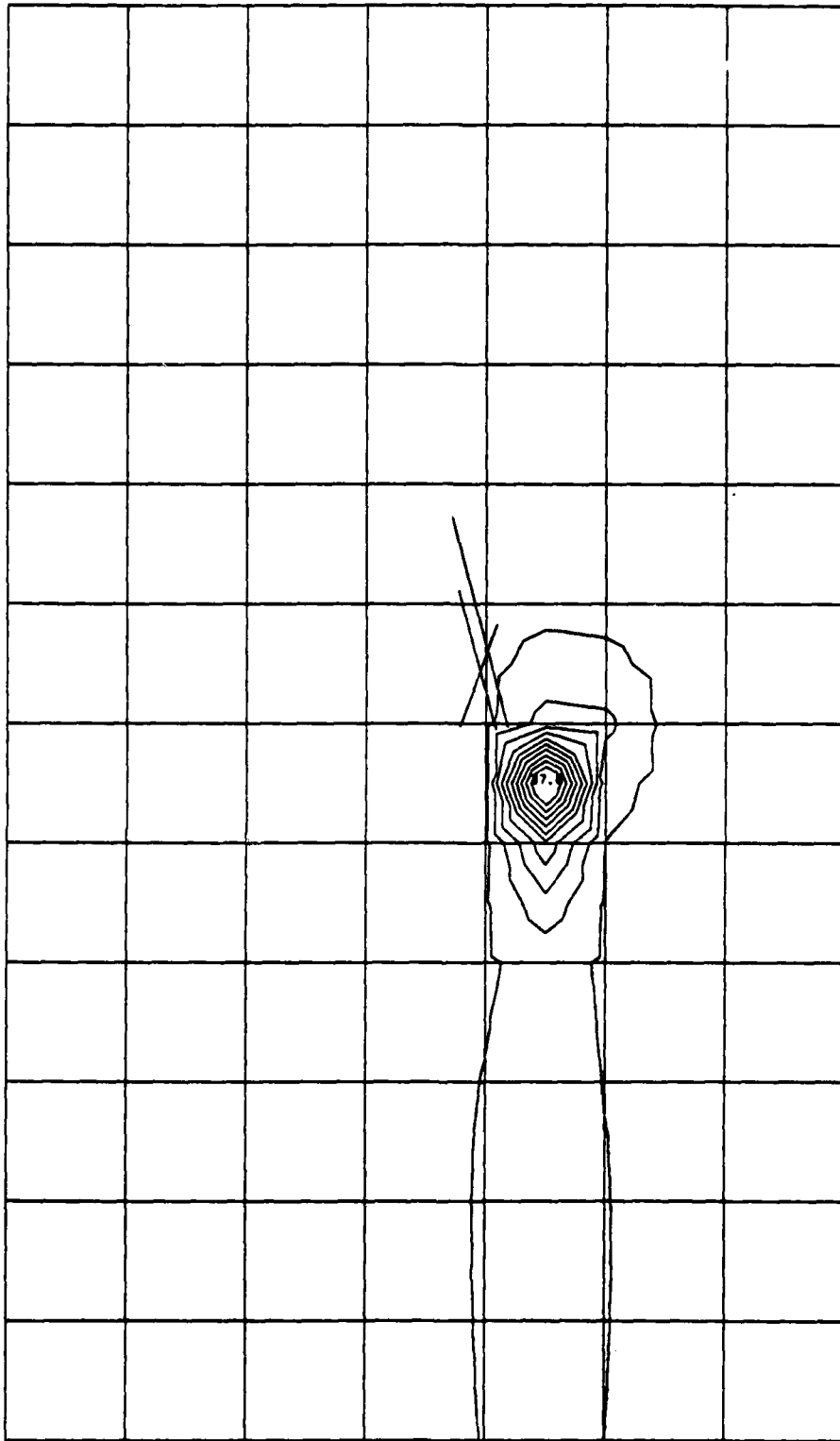

AIRBASE CO CONCENTRATION PROFILE (2 AUG 1500-1600)
INCREMENTED FROM 1.0
(Scale = $4 \mu\text{gm}/\text{m}^3$ per contour)

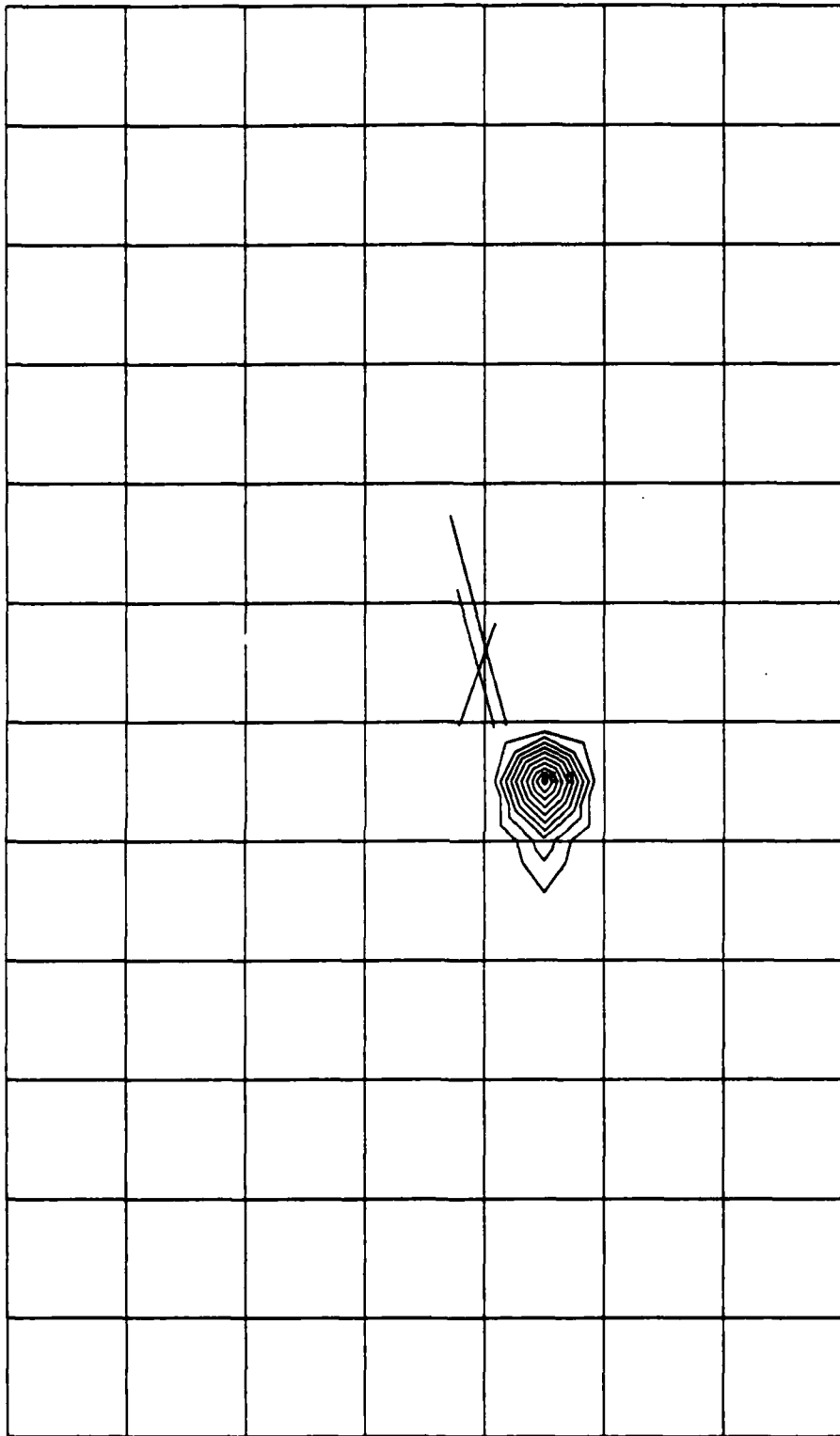

AIRBASE PT CONCENTRATION PROFILE (2 AUG 1500-1600)

INCREMENTED FROM 10.0

(Scale = $5 \mu\text{gm}/\text{m}^3$ per contour)

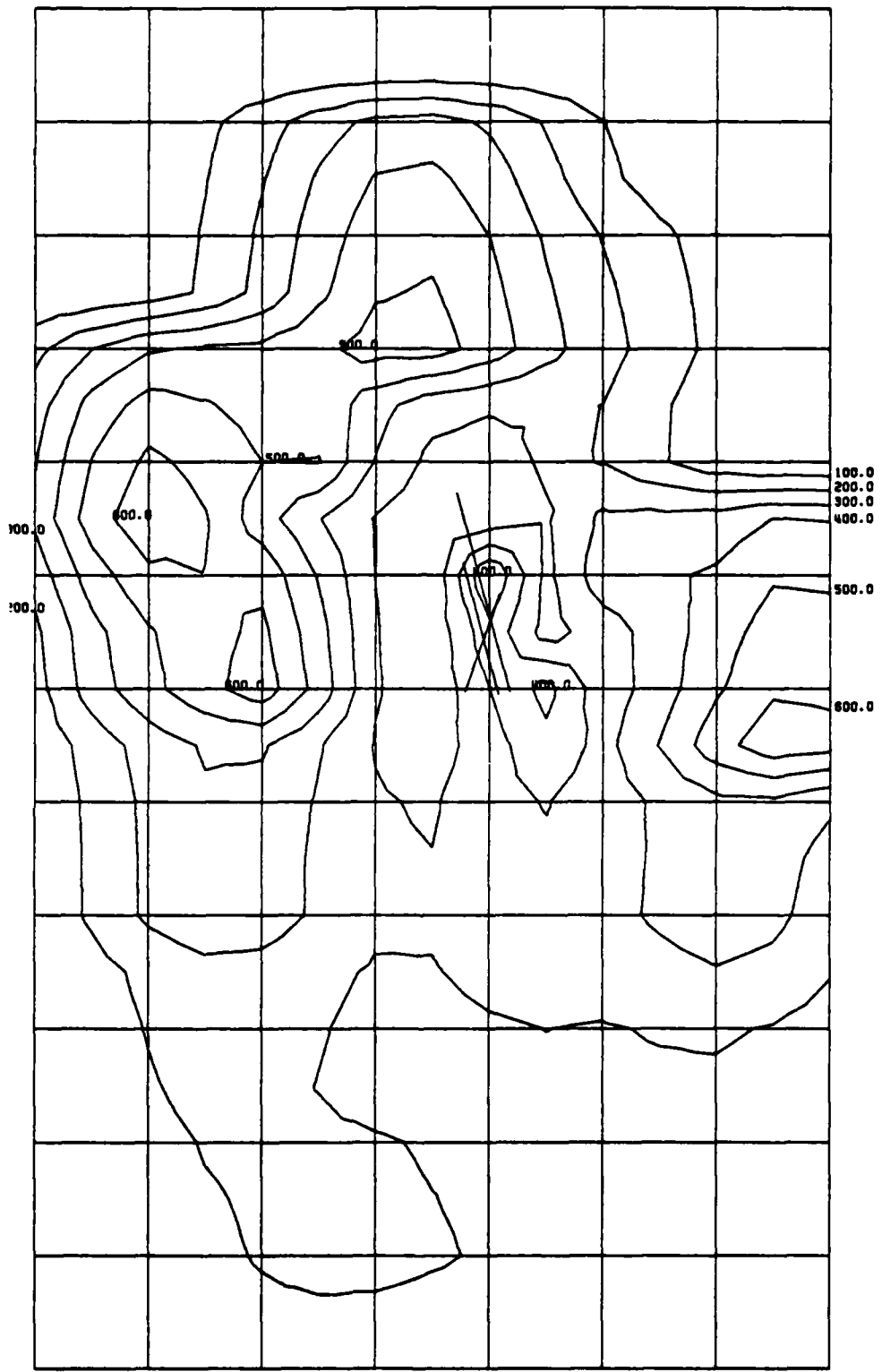

TOTAL CO CONCENTRATION PROFILE (2 AUG 1500-1600)
INCREMENTED FROM 100.0
(Scale = 100 $\mu\text{gm}/\text{m}^3$ per contour)

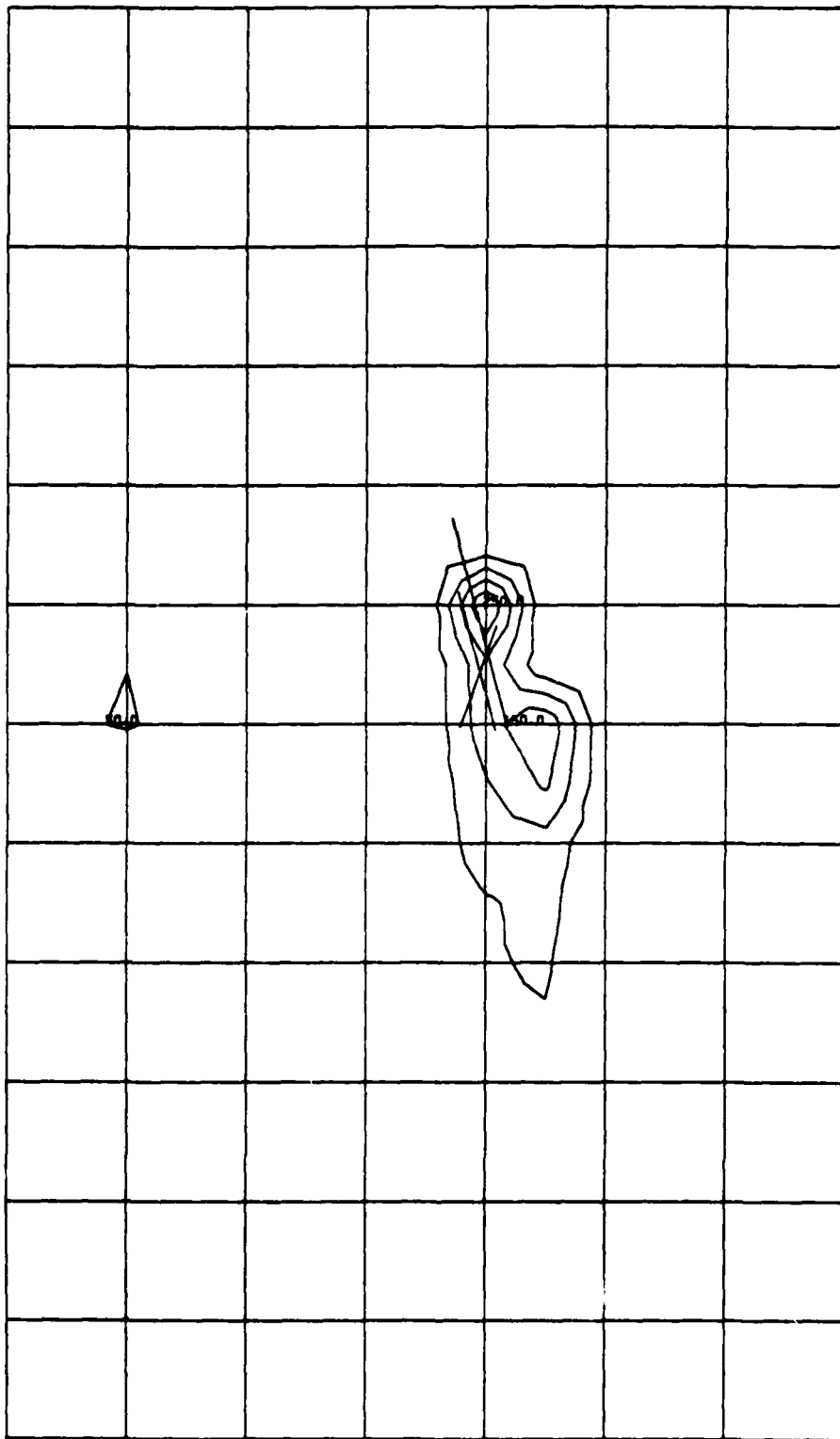

TOTAL PT CONCENTRATION PROFILE (2 AUG 1500-1600)
INCREMENTED FROM 50.0
(Scale = 50 $\mu\text{gm}/\text{m}^3$ per contour)

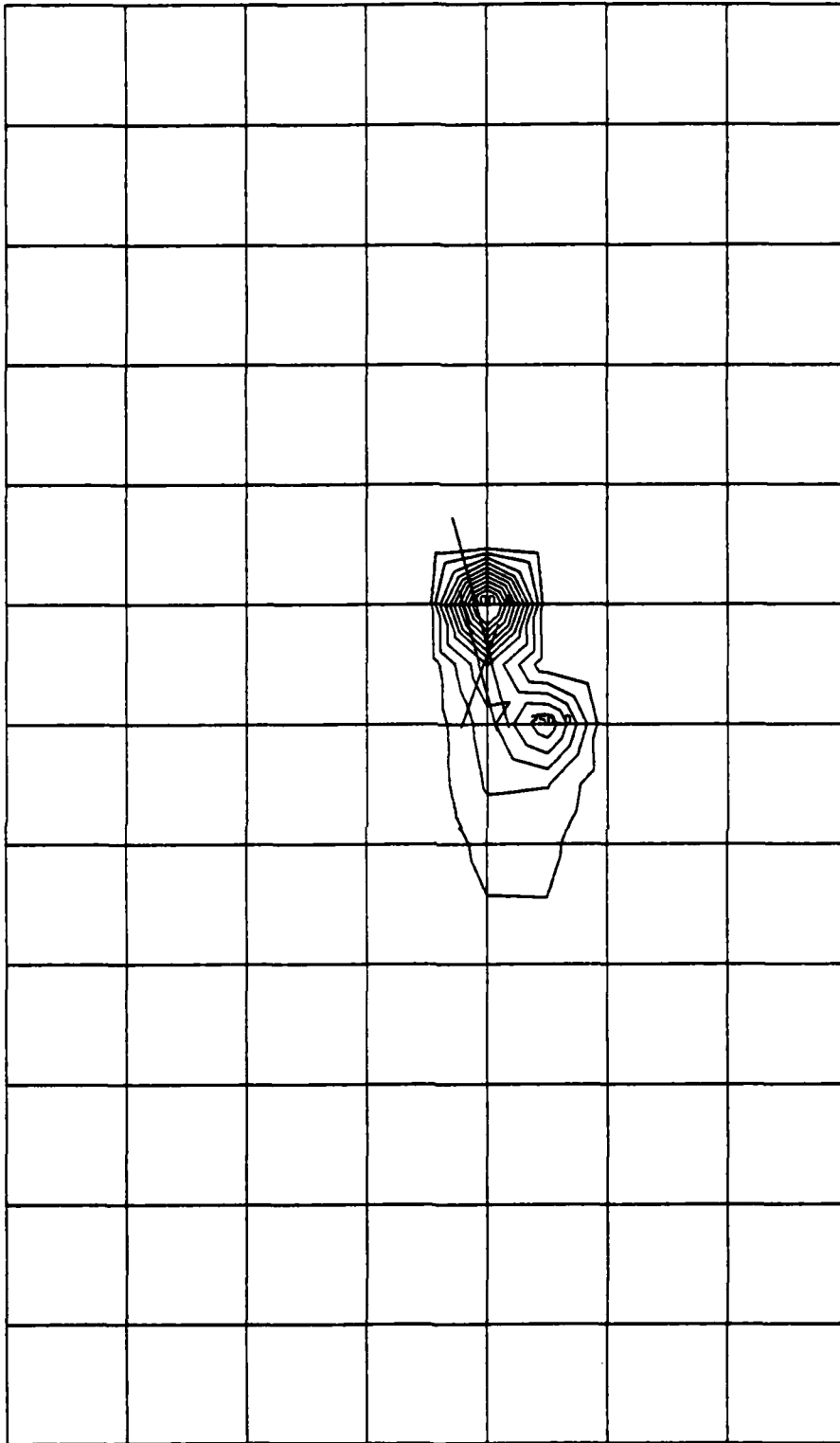

AIRCRAFT CO CONCENTRATION PROFILE (2 AUG 1515-1615)
INCREMENTED FROM 50.0

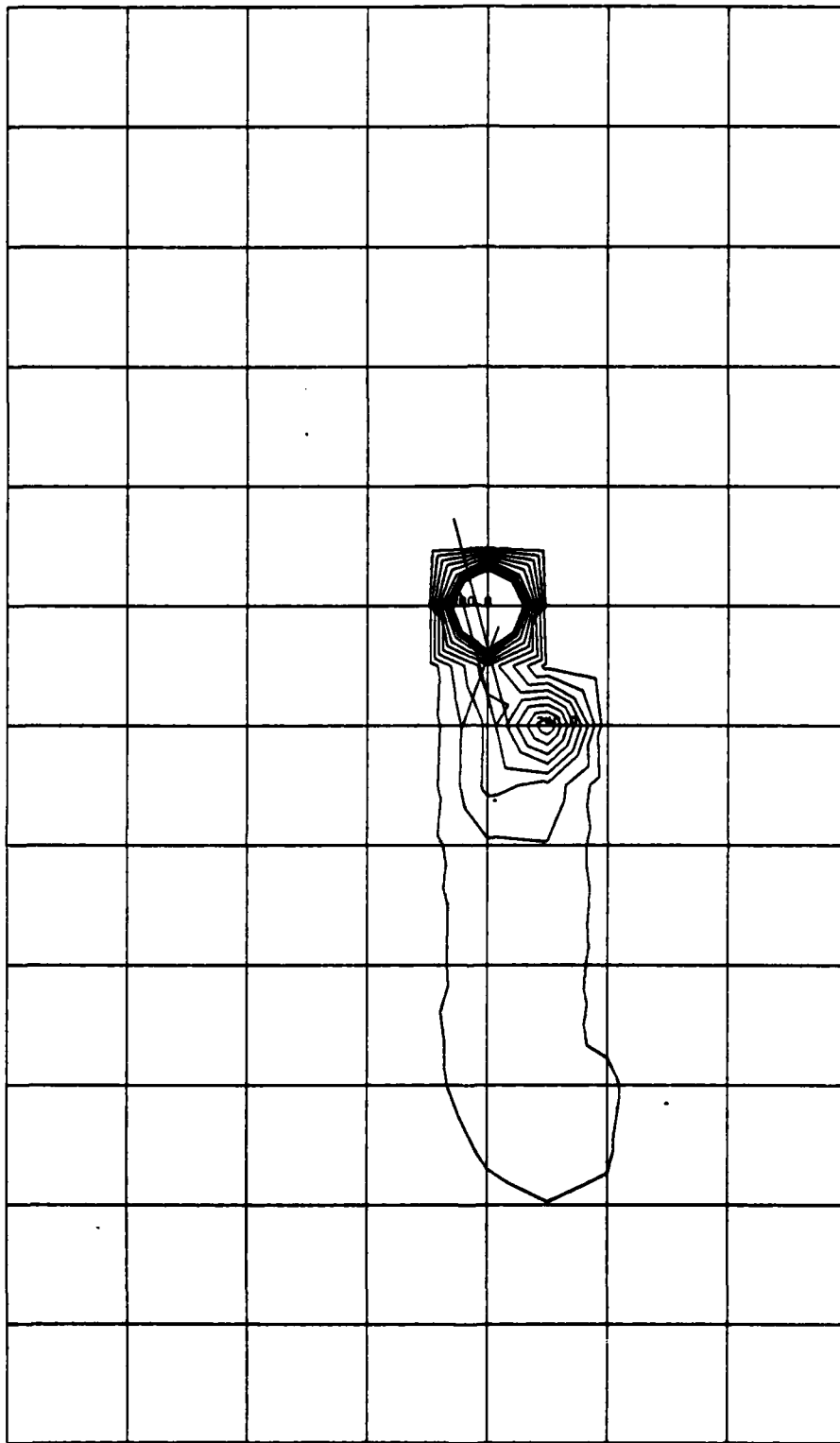

AIRCRAFT PT CONCENTRATION PROFILE (2 AUG 1515-1615)
INCREMENTED FROM 30.0

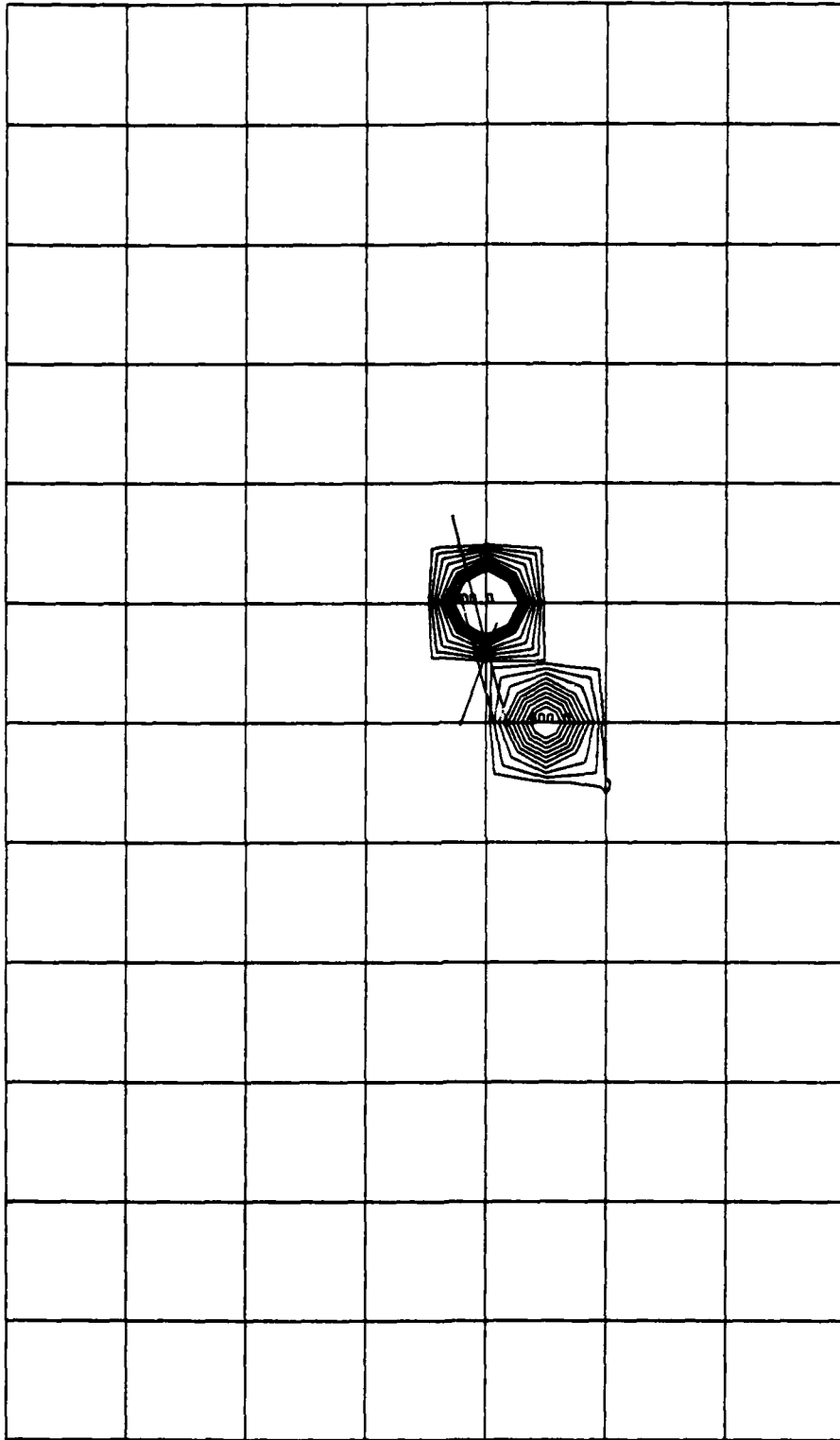

AIRCRAFT CO CONCENTRATION PROFILE (3 AUG 1100-1200)
INCREMENTED FROM 50.0

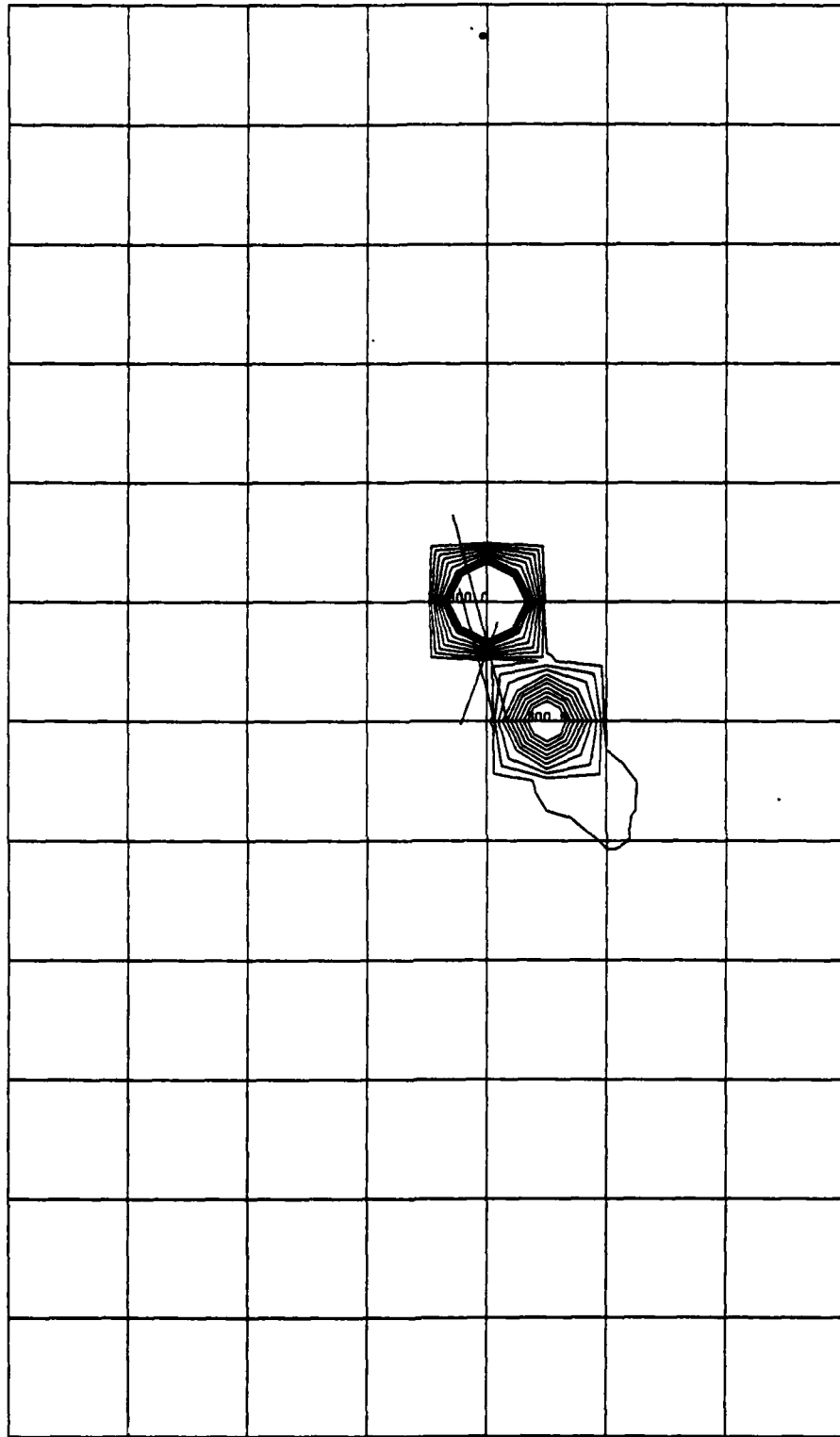

AIRCRAFT PT CONCENTRATION PROFILE (3 AUG 1100-1200)
INCREMENTED FROM 30.0

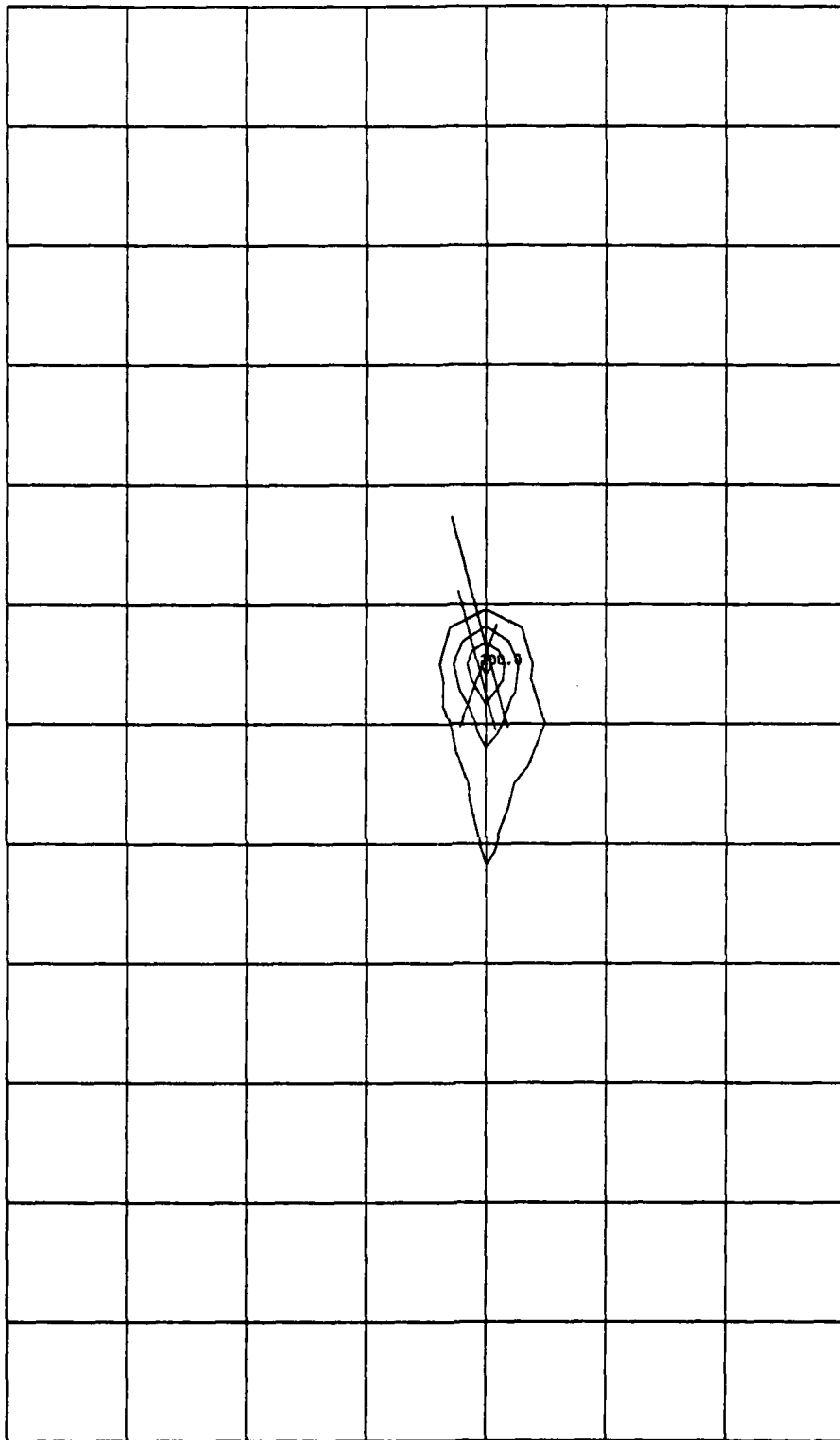

AIRCRAFT CO CONCENTRATION PROFILE (6 AUG 1400-1500)
INCREMENTED FROM 50.0

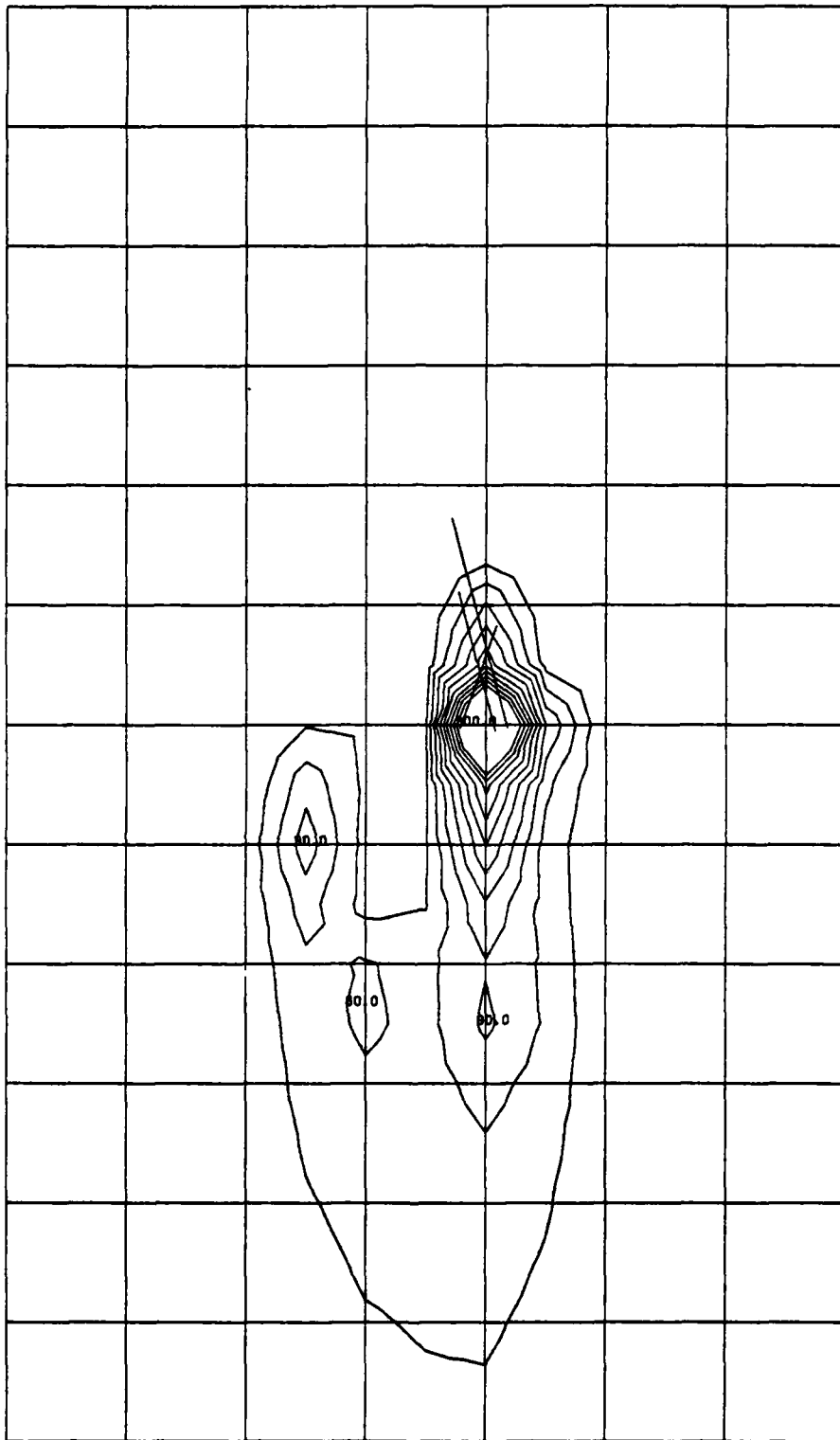

AIRCRAFT PT CONCENTRATION PROFILE (6 AUG 1400-1500)
INCREMENTED FROM 30.0

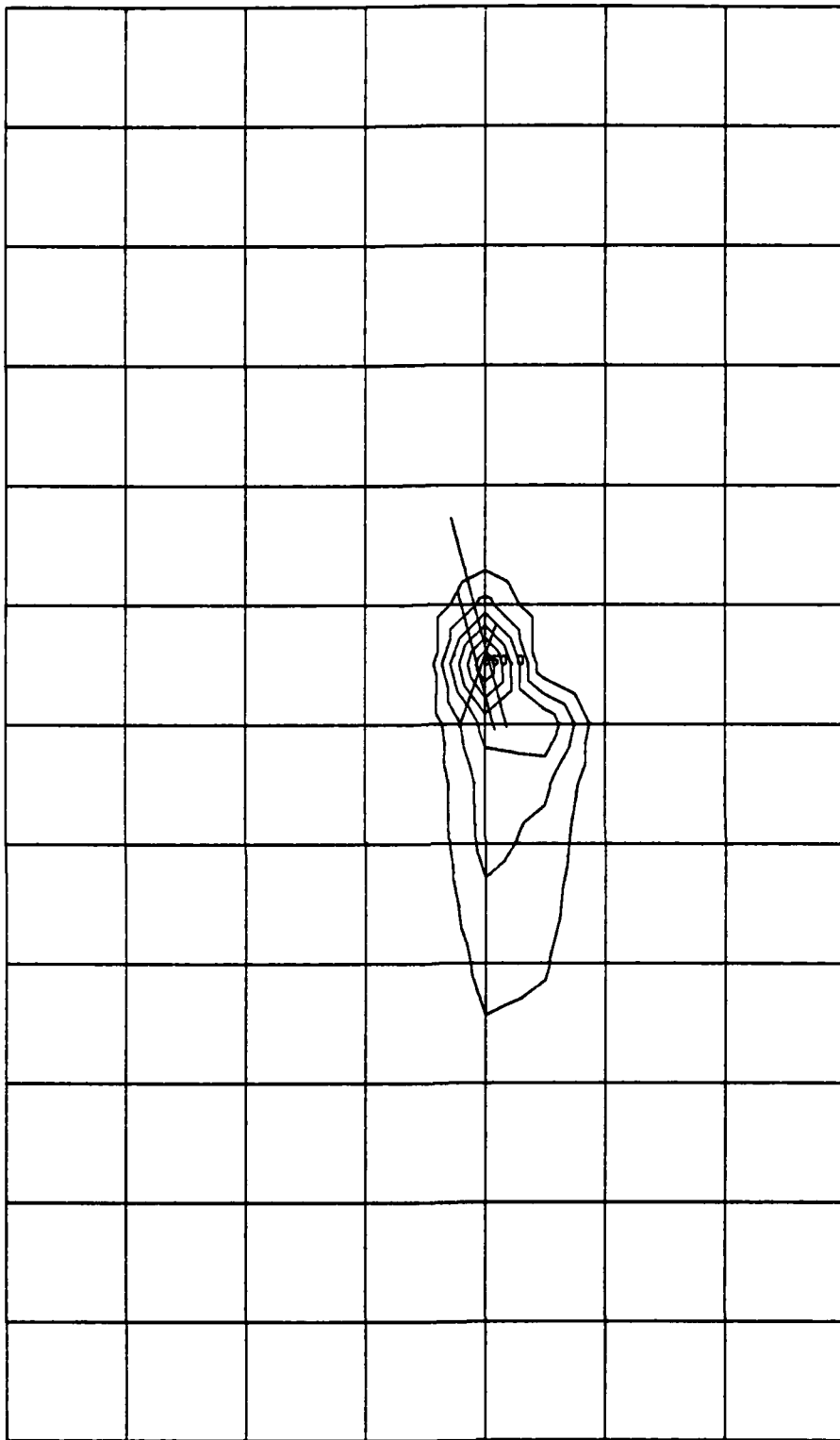

AIRCRAFT CO CONCENTRATION PROFILE (6 AUG 1500-1600)
INCREMENTED FROM 50.0

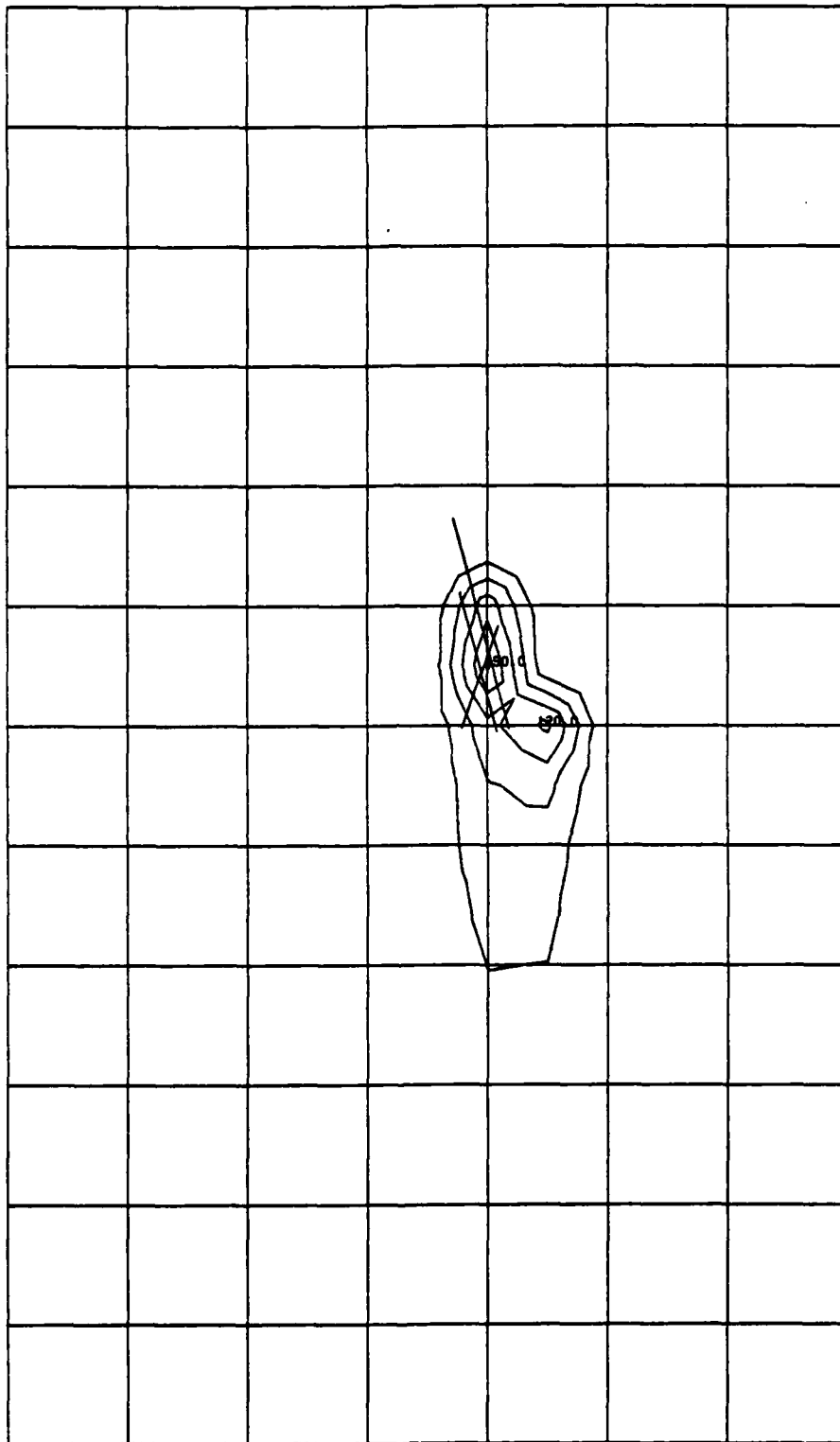

AIRCRAFT PT CONCENTRATION PROFILE (6 AUG 1500-1600)
INCREMENTED FROM 30.0

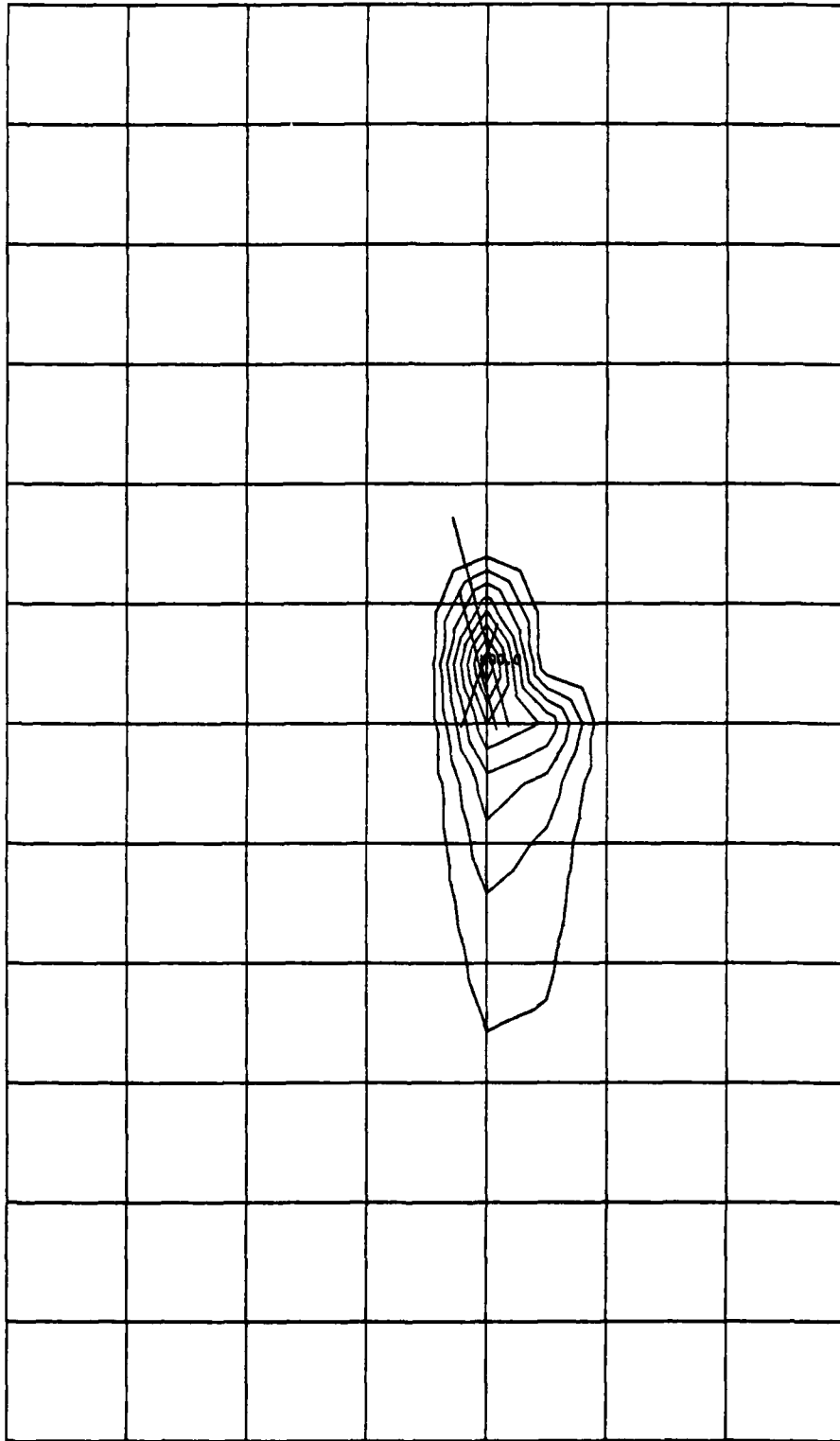

AIRCRAFT CO CONCENTRATION PROFILE (6 AUG 1515-1615)
INCREMENTED FROM 50.0

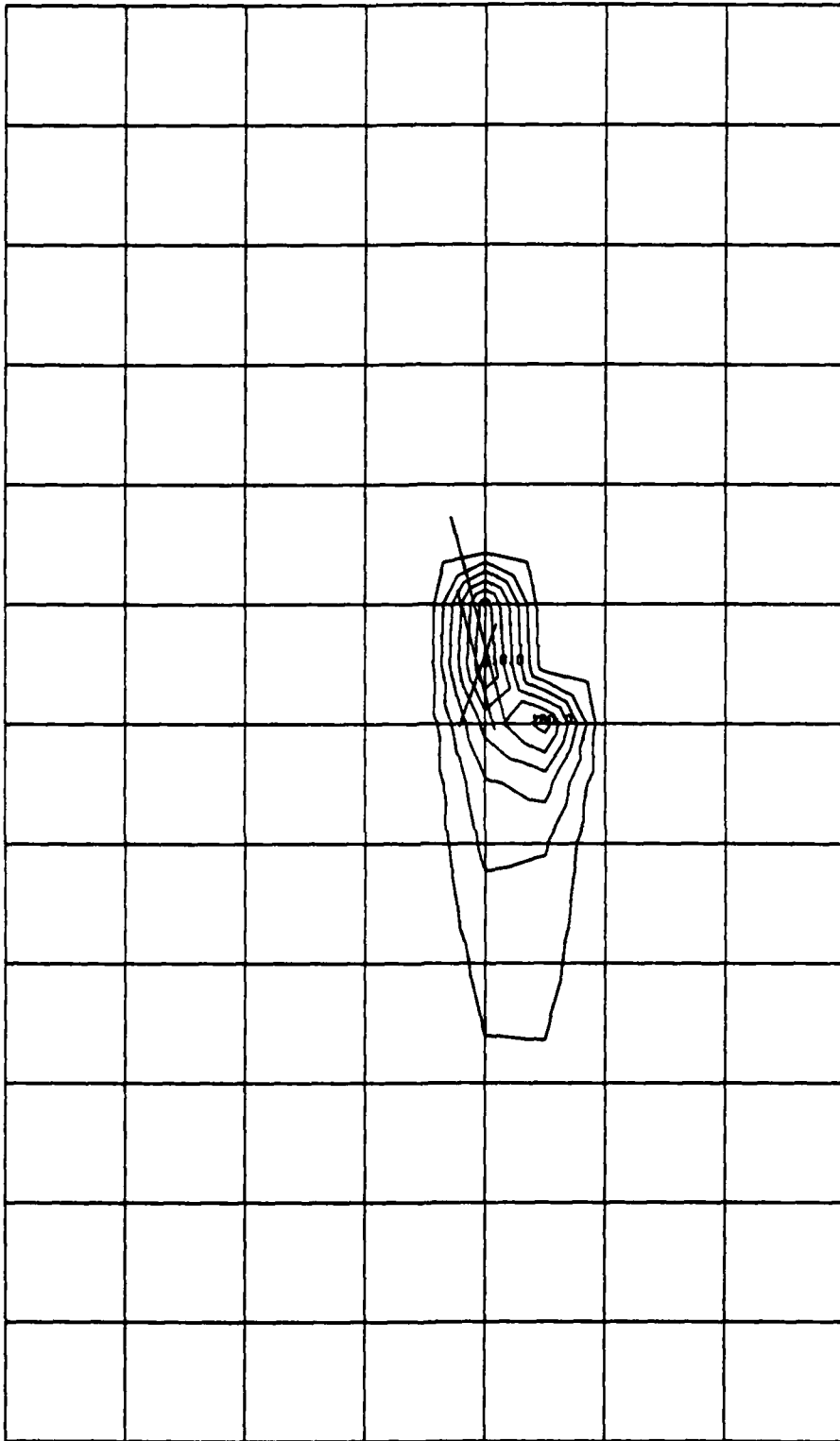

AIRCRAFT PT CONCENTRATION PROFILE (6 AUG 1515-1615)
INCREMENTED FROM 30.0

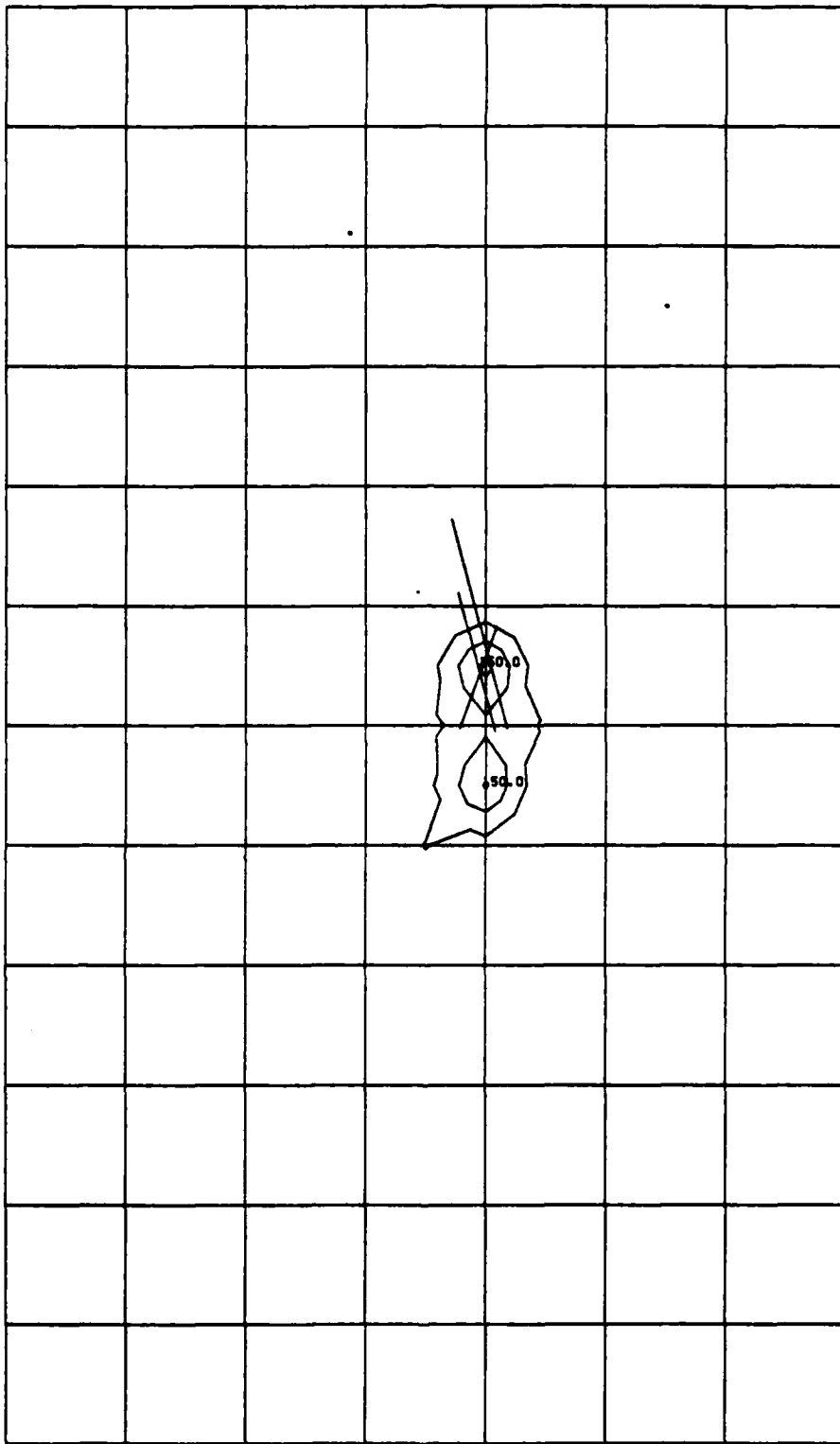

AIRCRAFT CO CONCENTRATION PROFILE (7 AUG 1500-1600)
INCREMENTED FROM 50.0

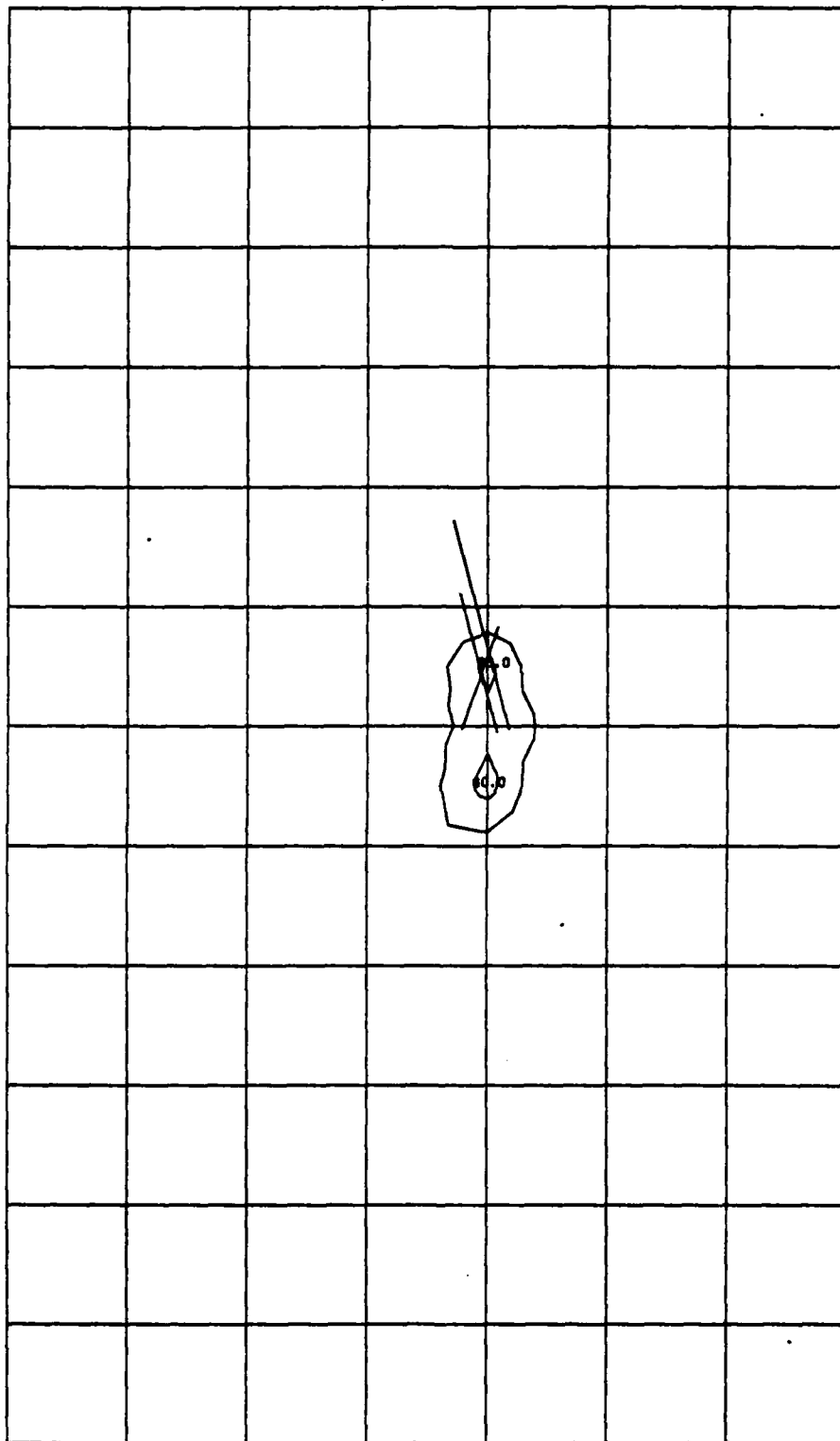

AIRCRAFT PT CONCENTRATION PROFILE (7 AUG 1500-1600)
INCREMENTED FROM 30.0

LIST OF REFERENCES

1. Northern Research and Engineering Corporation Report 1167 (Volumes 1 and 2), The Potential Impact of Aircraft Emissions on Air Quality, by M. Platt, R. C. Baker, E. K. Bastress, K. M. Chug and R. D. Siegel, 1971.
2. GEOMET, Inc. Report EF-262, Model Verification-Aircraft Emissions Impact on Air Quality, by S. D. Thayer, D. J. Felton, G. H. Stadskev and B. D. Weaver, 1974.
3. Air Force Weapons Laboratory Technical Report-74-304, A Generalized Air Quality Assessment Model for Air Force Operations, by D. M. Rote and L. E. Wangen, March 1975.
4. TRW Systems Group Report NTIS no. PB-189194, Air Quality Display Model, November, 1969.
5. J. H. Wiggins, Co., Report No. 75-1231-1, A Survey of Computer Models for Predicting Air Pollution From Airports, by J. M. Haber, May 1975.
6. EPA Environmental Monitoring and Support Laboratory Contract No. 68-03-2591, Williams Air Force Base Air Quality Monitoring Operations, by D. C. Sheesley, S. J. Gordon, M. L. Ehlert, D. F. Zeller, and J. C. Connolly.
7. G. R. Thompson and D. W. Netzer, An Ambient Air Quality Model for Assessment of U. S. Naval Aviation Emittants, Naval Postgraduate School, Monterey, CA, Technical Report NPS-67Nt76091, September 1976.
8. K. I. Weal and D. W. Netzer, Modification of an Ambient Air Quality Model for Assessment of U. S. Naval Aviation Emittants, Naval Postgraduate School, Monterey, CA, Technical Report NPS-57Nt75071A, August 1975.
9. Naval Postgraduate School Technical Report NPS-67Nt78051, Sensitivity of AQAM Predictions for Naval Air Operations to Meteorological and Dispersion Model Parameters, by D. W. Netzer, May 1978.
10. D. M. Rote, R. J. Yamartino, K. L. Brubaker, Preliminary Evaluation of AQAM at Williams AFB, paper, presented at Air Quality and Aviation: An International Conference, Reston, VA, 16-18 October 1978.

11. Naval Air Propulsion Center Letter PE71:AFK 10340 Serial F924 to Commanding Officer, NAS Miramar, Subject: Effects of Aircraft Operations on Air Quality; NAS Miramar test for, 12 February 1979.
12. Air Force Weapons Laboratory Technical Report-74-54, A Generalized Air Quality Assessment Model-An Operator's Guide, by Argonne National Laboratory, July 1974 (Ref. May 1975).
13. EPA Report No. AP-26, Workbook of Atmospheric Dispersion Estimates, by D. B. Turner, 1970.
14. J. V. Brendmoen and D. W. Netzer, Measurements of Jet Dispersion Simulated in an Aeronautical Wind Tunnel, Naval Postgraduate School, Monterey, CA, Technical Report NPS-67-79-012, September 1979.
15. Williamson, S. J., Fundamentals of Air Pollution, Addison-Wesley, 1973.

INITIAL DISTRIBUTION LIST

	No. Copies
1. Defense Documentation Center Cameron Station Alexandria, Virginia 22314	2
2. Library, Code 0142 Naval Postgraduate School Monterey, California 93940	2
3. Department Chairman, Code 67P1 Department of Aeronautics Naval Postgraduate School Monterey, California 93940	1
4. Professor D. W. Netzer, Code 67Nt Department of Aeronautics Naval Postgraduate School Monterey, California 93940	2
5. LCDR T. S. Douglas 3840 So. Hillcrest Drive Denver, Colorado 80237	2

