

AD-A082 020

ARMY COMMUNICATIONS RESEARCH AND DEVELOPMENT COMMAND --ETC F/6 17/2

A TIME DIVISION DEMAND ACCESS INTERCOM SYSTEM.(U)

FEB 80 G S WILLIMAN

UNCLASSIFIED

CORADCOM-80-1

NL

1 - 1

400 000

END

DATE

FILED

4 80

DTIC

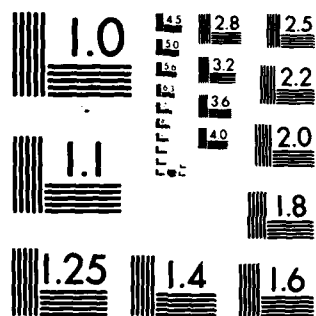

MICROCOPY RESOLUTION TEST CHART  
NATIONAL BUREAU OF STANDARDS 1963 A



**LEVEL**

12

14

RESEARCH AND DEVELOPMENT TECHNICAL REPORT  
CORADCOM- 80-1

ADA 082 020

A TIME DIVISION DEMAND ACCESS INTERCOM SYSTEM

DTIC  
SELECTE  
MAR 19 1980  
S D C

Glenn S. Williman  
CENTER FOR COMMUNICATIONS SYSTEMS

February 1980

DISTRIBUTION STATEMENT  
Approved for public release;  
distribution unlimited.

DDC FILE COPY

**CORADCOM**

U S ARMY COMMUNICATIONS RESEARCH & DEVELOPMENT COMMAND  
FORT MONMOUTH, NEW JERSEY 07703

80 3 18 027

## **NOTICES**

### **Disclaimers**

**The citation of trade names and names of manufacturers in this report is not to be construed as official Government indorsement or approval of commercial products or services referenced herein.**

### **Disposition**

**Destroy this report when it is no longer needed. Do not return it to the originator.**

UNCLASSIFIED

SECURITY CLASSIFICATION OF THIS PAGE (When Data Entered)

REPORT DOCUMENTATION PAGE

READ INSTRUCTIONS  
BEFORE COMPLETING FORM

14

1. REPORT NUMBER  
CORADCOM-86-1

2. GOVT ACCESSION NO.

3. RECIPIENT'S CATALOG NUMBER  
9

6

4. TITLE (and Subtitle)  
A Time Division Demand Access Intercom System

5. TYPE OF REPORT PERIOD COVERED  
Final rept.  
January 1978 - November 1979

10

7. AUTHOR(s)  
Glenn S. Willman

8. CONTRACT OR GRANT NUMBER(s)

9. PERFORMING ORGANIZATION NAME AND ADDRESS  
US Army Communications Research & Development Cnd  
ATTN: DRDCO-COM-RN-3  
Fort Monmouth, NJ 07703

10. PROGRAM ELEMENT, PROJECT, TASK AREA & WORK UNIT NUMBERS  
6946 5055 5790304

11. CONTROLLING OFFICE NAME AND ADDRESS  
Same As Above

12. REPORT DATE  
February 1980  
13. NUMBER OF PAGES  
30

14. MONITORING AGENCY NAME & ADDRESS (if different from Controlling Office)  
1234

15. SECURITY CLASS. (of this report)  
UNCLASSIFIED  
15a. DECLASSIFICATION/DOWNGRADING SCHEDULE

16. DISTRIBUTION STATEMENT (of this Report)  
Approved for Public Release, Distribution Unlimited

17. DISTRIBUTION STATEMENT (of the abstract entered in Block 20, if different from Report)

18. SUPPLEMENTARY NOTES

19. KEY WORDS (Continue on reverse side if necessary and identify by block number)  
Intercommunication System  
Time Division Multiplexing  
Demand Access Intercom System

20. ABSTRACT (Continue on reverse side if necessary and identify by block number)  
This report describes the design of a vehicular intercommunication system using a time division demand access technique. The resulting design is a digital voice intercom using fewer A-D/D-A conversions and therefore less hardware than most conventional digital voice systems. Other advantages are decreased system cost and increased system signal to noise ratio.

DD FORM 1 JAN 78 1473

EDITION OF 1 NOV 68 IS OBSOLETE

410489

UNCLASSIFIED

SECURITY CLASSIFICATION OF THIS PAGE (When Data Entered)

LB

## A TIME DIVISION DEMAND ACCESS INTERCOM SYSTEM

### PREFACE

The CORADCOM vehicular intercom development program is exploring new designs for vehicular intercom systems. The design goals for the new system include the following:

- a. multiplexing techniques in order to reduce cable and connector sizes
- b. wireless techniques in order to eliminate the cord between the crewman's helmet and his intercom station
- c. improved system intelligibility
- d. simple, accident free keying capability.

Contracts have been awarded to ITT Aerospace/Optical Division (DAAB07-77-C-0189) and Cincinnati Electronics Corporation (DAAB07-77-C-0190) to develop concepts for system architecture, signal distribution and wireless communications. In addition to this work, which addressed the full spectrum of intercom system design goals, a concept dealing only with multiplexed signal distribution for an intercom system was developed in house by CORADCOM. This work is the subject of this report. The design was prototyped to verify operational feasibility, but in order to build the prototype only readily available components were used. Therefore, the schematics do not necessarily represent an optimized design, but they do show a simple and straightforward system implementation. For additional information on the intercom system design as performed under contract, a list of the contractors' reports are included in appendix A.

Accession For	
NTIS GRA&I	<input checked="" type="checkbox"/>
DDC TAB	<input type="checkbox"/>
Unannounced	<input type="checkbox"/>
Justification	
By _____	
Distribution/	
Availability Codes	
Dist	Availability Code
A	

## TABLE OF CONTENTS

	<u>Page</u>
Introduction . . . . .	1
Operational Description . . . . .	1
Bus Concept . . . . .	2
Bus Protocol . . . . .	5
Controller Operating Description . . . . .	6
Crew Station Operating Description . . . . .	16
Summary . . . . .	26
Appendix A . . . . .	28

## FIGURES

Figure 1	System Block Diagram	3
Figure 2	Data Structure	4
Figure 3	Controller Block Diagram	7
Figure 4	Demultiplexing	8
Figure 5	Control Timing Generator	9
Figure 6	Control Channel Generators	10
Figure 7	Control Receive Latches	11
Figure 8	Control Priority Decoding	12
Figure 9	Control Mode Decoding	13
Figure 10	Control Bus Interface	14
Figure 11	Control Station Audio	15
Figure 12	Crew Station Block Diagram	17

## FIGURES (CONT)

		<u>Page</u>
Figure 13	Frame Definition	19
Figure 14	Bus Interface	20
Figure 15	Timing Generator	21
Figure 16	Receive Bit Latches	22
Figure 17	Offset Generator	23
Figure 18	Front Panel Controls	24
Figure 19	Crew Station Audio	25

## INTRODUCTION

An intercom system is normally thought of as a system which allows communication between individuals in a manner much like the telephone i.e., users operating in a full duplex mode or talking simultaneously. This type of system must accommodate information travelling in two directions at the same time on the same wire pair, and generally uses large and expensive hybrid transformers for analog systems or very fast data rates for digital systems. Systems which allow only one user to talk at a time are a type of simplex system, and are generally less costly and more easily implemented. However, in some situations the operational restrictions may be inconvenient.

While a full duplex communication system may seem to be the ideal system for some intercom applications, the assumption for the design of the time division demand access intercom is that a full duplex system is neither necessary nor ideal for the combat vehicle environment. The operational scenario of most combat vehicles is one in which the crew members take orders from the vehicle commander and respond with confirmation to these orders. This type of intercom traffic could efficiently be handled by a simplex type system with a minimum amount of user discipline. It is an approach naturally suited to the type of traffic encountered in the vehicle.

## OPERATIONAL DESCRIPTION

Consider a typical intercom system comprised of a control station and four crew stations. One of the crew stations can be designated the commander's station. The first person to begin speaking will be recognized by the control station, and the control station will then inhibit all other crew stations. The system uses noise immune voice operated keying (VOX) of the crew stations, so if the first talker pauses longer than a predetermined time or stops talking, the intercom voice channel is available for another user. The use of noise immune VOX keying allows the operator to activate the system without any real effort and will automatically unkey the system when the operator stops talking. This feature is particularly important because the system can only accommodate one talker at any given time. In order to have control of the system, one must continually talk. This is the basis for the design of the system; if there is a demand for voice access to the intercom, the system will respond by allowing that information to pass providing the voice channel is idle. Since most voice traffic will be of the command and response type format, the demand access design can efficiently and economically satisfy the voice traffic pattern in the vehicle. There is, however, no doubt that system discipline and dependence on traffic protocol is required to achieve the effectiveness of the system; but this is considered reasonable for combat vehicle intercom communications.

Monitoring of vehicle radios is done independently of the intercom voice channel, so each crew member can monitor, uninterrupted, whatever radio channel is desired. However, when a crew member wishes to key a radio, the constraints of the demand access system again apply; the voice channel must be idle before a transmission can take place. To key the radio there is a momentary contact switch located on the crew station which must be manually held down during the entire radio transmission time, but the modulation of the radio transmitter will still be controlled by the crew station VOX circuit. In this manner accidental VOX keying of the radio will not occur, and during long periods of pauses in speech, vehicle background noise will not modulate the transmitter.

Since the commander's crew station is partitioned separately in the time division multiplexed (TDM) data format, the controller can recognize it and distinguish it from the other crew stations. In this manner priority interrupts or priority radio transmissions for the commander could be easily programmed into the control station logic. This has not been implemented in this model since it still is uncertain as to what system capabilities should be assigned to which crew stations i.e., it is a possibility that all crew stations except the commander's crew station will not require any radio transmission capability. Once the system operational requirements are clearly defined, it is felt that the time division demand access concept can satisfy these requirements with a highly cost effective system.

#### BUS CONCEPT

The system operates from two synchronous bus lines; one for digital data and one for system clock. This approach of using a separate clock bus, rather than combining clock and data, was chosen in order to keep the hardware as simple and inexpensive as possible. The system is comprised of a controller and individual crew stations. The controller generates the system clock, interfaces with the vehicle radio systems, and determines which crew station may talk on the data bus based on a pre-defined priority scheme. The crew stations handle the crew member's A-D/D-A (CVSD) conversion, provide VOX control of microphone audio, selectively monitor the vehicle radio systems, and provide intercom and radio transmission capability. A system block diagram is shown in Figure 1.

The clock signal, generated at the controller, is 1.75 MHz and is received at each crew station and used as the basis for crew station timing. The data signal is formatted into a frame which must be transmitted at the rate desired for CVSD modulation/demodulation; in this case, 35 kHz. Each frame is comprised of 5 data channels, and each data channel is comprised of 10 bits. The data structure is shown in Figure 2. With this number of channels the bus overhead is very low, and since all overhead resides with the controller; there is sufficient room for expansion in the controller generated data channels (control & receive channels) to readily allow for system modification and flexibility.

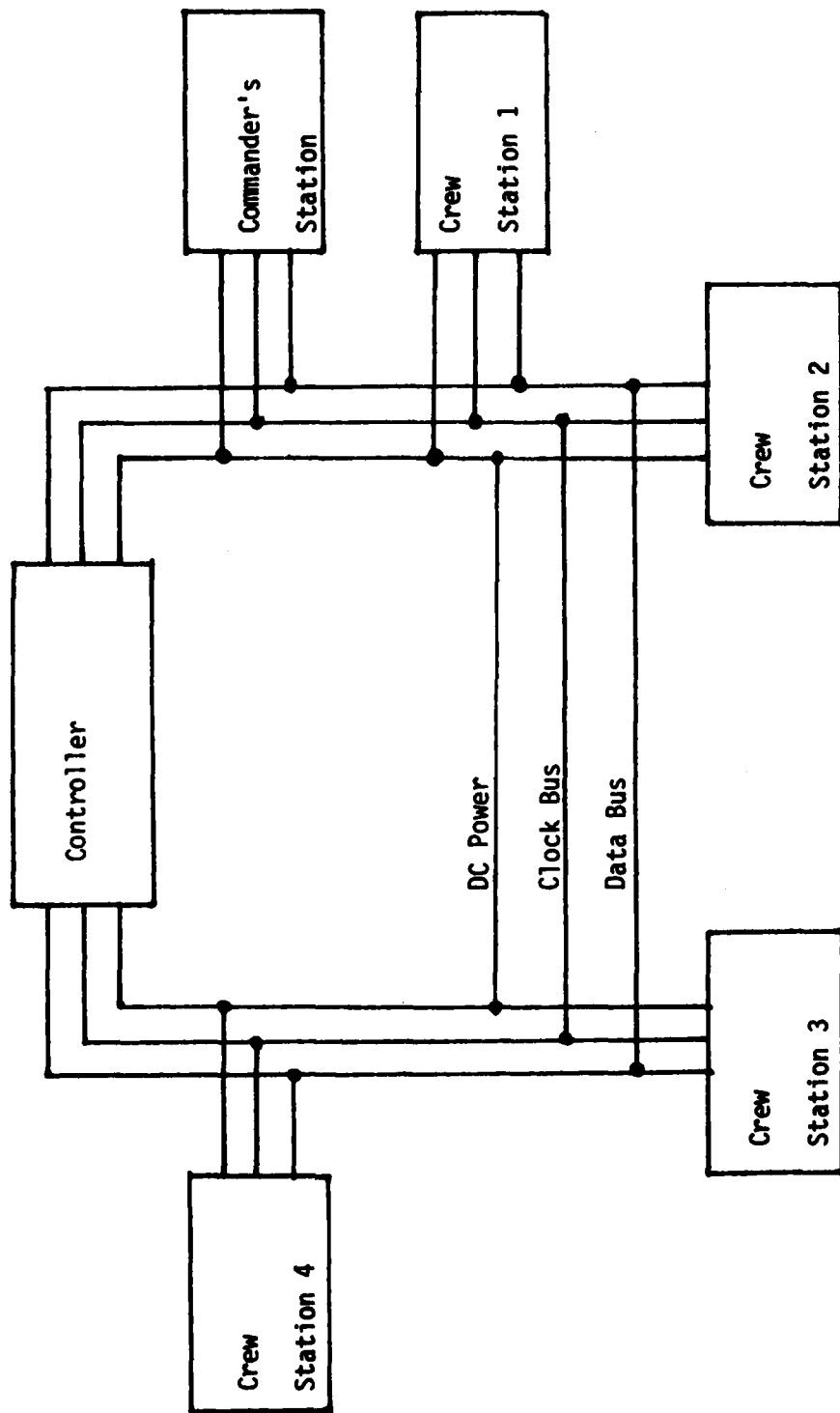

Figure 1 System Block Diagram

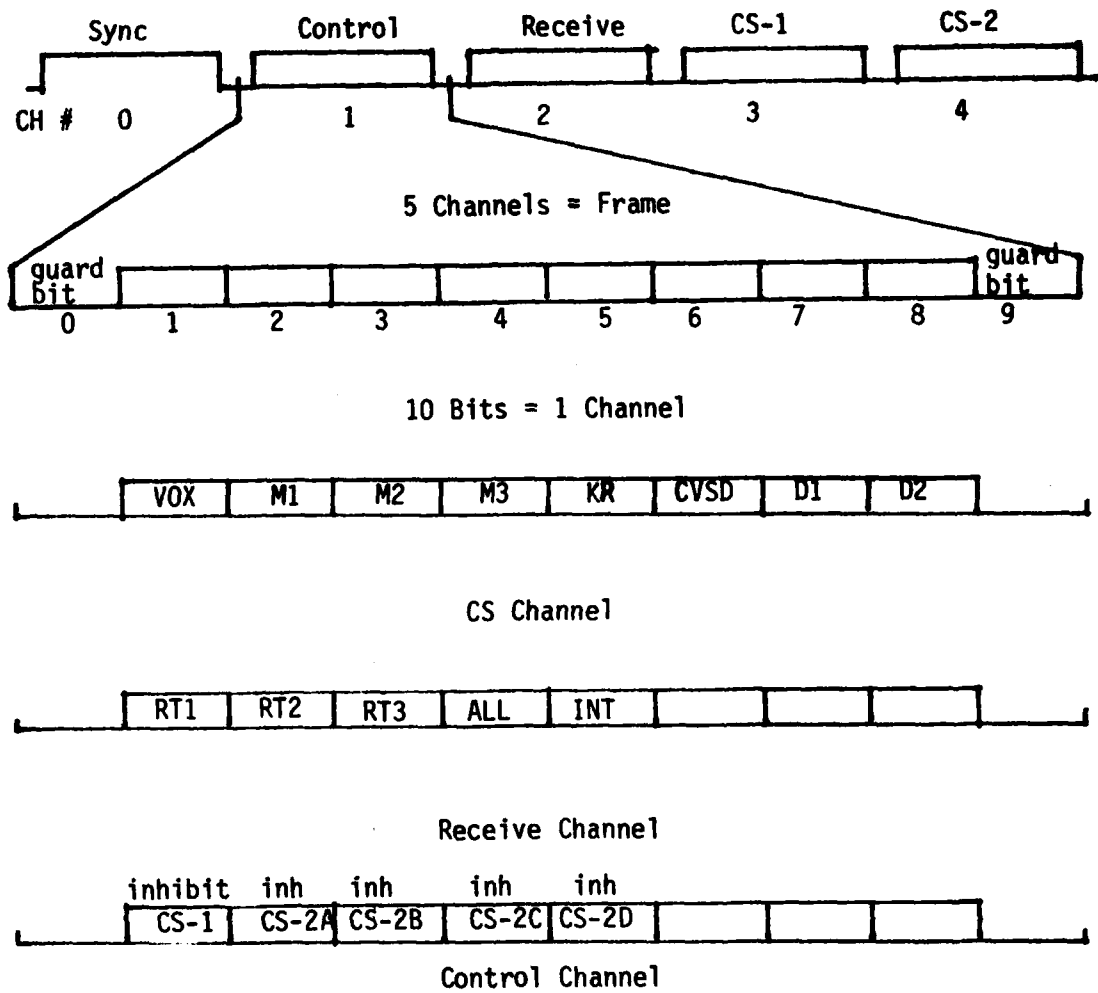

Figure 2 Data Structure

## BUS PROTOCOL

The system is based on the premise that at any given time only one crew member (including the commander) can talk on the data bus. The main advantage of this approach is that no conference bridge is required in the system controller, and it eliminates a D-A and A-D transformation which would be required in systems allowing for simultaneous talkers. Every time a transformation from analog to digital signals is made, or vice versa, the system signal to noise ratio is degraded. Another advantage from system security aspects is the capability of allowing only one RT to be modulated at a time. Not only does the elimination of the D-A and A-D transformation serve to maintain system signal to noise ratio, but it also considerably reduces controller hardware complexity. For example, in a system where the conference bridge is used in the controller, a separate CVSD must be dedicated to each crew channel in order to decode that channel. An analog network must then combine the signals, and this combined (conferenced) signal must be re-encoded with an intercom channel CVSD.

One key to the successful operation of this concept lies in the use of a reliable VOX circuit at each crew station. This VOX must have vehicle noise immunity and operate reliably on voice signals with fast attack and release times. The fast release is required in order that another talker may then break in and use the system. When the user wishes to key a radio, the VOX release time constant can be automatically lengthened in order to prevent excessive on and off keying of the radio. Therefore, a user who is transmitting on radio has an advantage in maintaining the data bus for his use. Given the low volume of traffic in tactical vehicles, this system is certainly a viable implementation of an intercom system.

The prototype developed is configured for the commander to occupy the CS-1 data channel, and for up to four crew members to share the CS-2 channel with all users operating in a time division demand access arrangement. By separating the commander's channel this way, priority access could easily be implemented in the controller. However, for this prototype all users operate on an equal weight demand access scheme (first come, first served). The commander operates on the CS-1 channel and all crew members share the CS-2 channel. Based on decoding the designator bits D1 and D2 from the CS-2 channel, the controller can identify which crew station is talking and simultaneously inhibit all other stations. In a totally equal weight demand access scheme, a maximum of 8 users could operate on this system; 4 users on the CS-1 channel and 4 users on the CS-2 channel.

## CONTROLLER OPERATING DESCRIPTION (Figures 5-11)

The controller block diagram is shown in Figure 3. The controller generates system timing and continually sends a 1.75 MHz clock over the clock bus. U1 and U2 form the master oscillator. The same basic demultiplexing scheme is used throughout the controller and all crew stations. Each channel is separated into 10 bits and the frame is separated into 5 channels (Figure 2). U3, U4, U5 and U6 define these different time intervals based on the master oscillator. Once these time intervals are defined, they are used in conjunction with the clock to become clock pulses for D type flip flops which latch (or demultiplex) the desired bit from the serial data bus. For example, in order for the controller to demultiplex or latch the D-1 bit from CS-2 (crew station # 2), three signals are required; the CS-2 channel bit, the D-1 data bit or data bit 7 and the clock signal.

The demultiplexing is then accomplished as shown in Figure 4. The latched output is updated every time signals A, B and C coincide; once every frame. In this system the frame rate is the CVSD clock rate so that the CVSD's can receive and send data on a real time basis on the data bus. The controller demultiplexes every bit from the crew stations in a similar manner.

In order for the system to operate on a demand access basis, the controller must partition the data and separate CS-1 data from CS-2 data. The controller must also determine which crew member spoke first. The first crew member to speak and be recognized is given transmission access to the data bus while all other stations are inhibited from transmitting by having the controller inhibit the crew stations's CVSD. Crew member demand is determined by detecting the VOX signal. The VOX signals from CS-1 and CS-2 are latched by U12 and applied to a first come, first served detector (FCFS) made up of U17, D1, D2, R1, R2 and U18 A, B, C. This circuit determines which VOX bit occurred first, as applied to inputs U17A and U17B, and then uses this information to control transmission of that channel's intercom bit through gates U18 A, B and C. The outputs are the speaker's intercom bit and an inhibit bit for all other crew members. Referring to the schematic in Figure 8, when there is a CS-1 channel speaker, the output of U17F goes low allowing this speaker to continue. Outputs from U17F and U19 A, B, C, D are held high inhibiting all CS-2 channel speakers. If a speaker on CS-2 is detected by a low output from U17F, this information also enables the output of the CS-2 decoder, U16, to identify which of the 4 possible users of CS-2 is speaking.

Once a talker has been identified the controller must then inhibit all other potential talkers. This is the purpose of the control channel generated by the controller. In this data channel there is a dedicated bit for each potential system user (a maximum of 8 stations). The crew stations constantly monitor their respective bit in this channel. This bit, when detected at the crew station, will maintain the crew station CVSD in a decode (D-A)

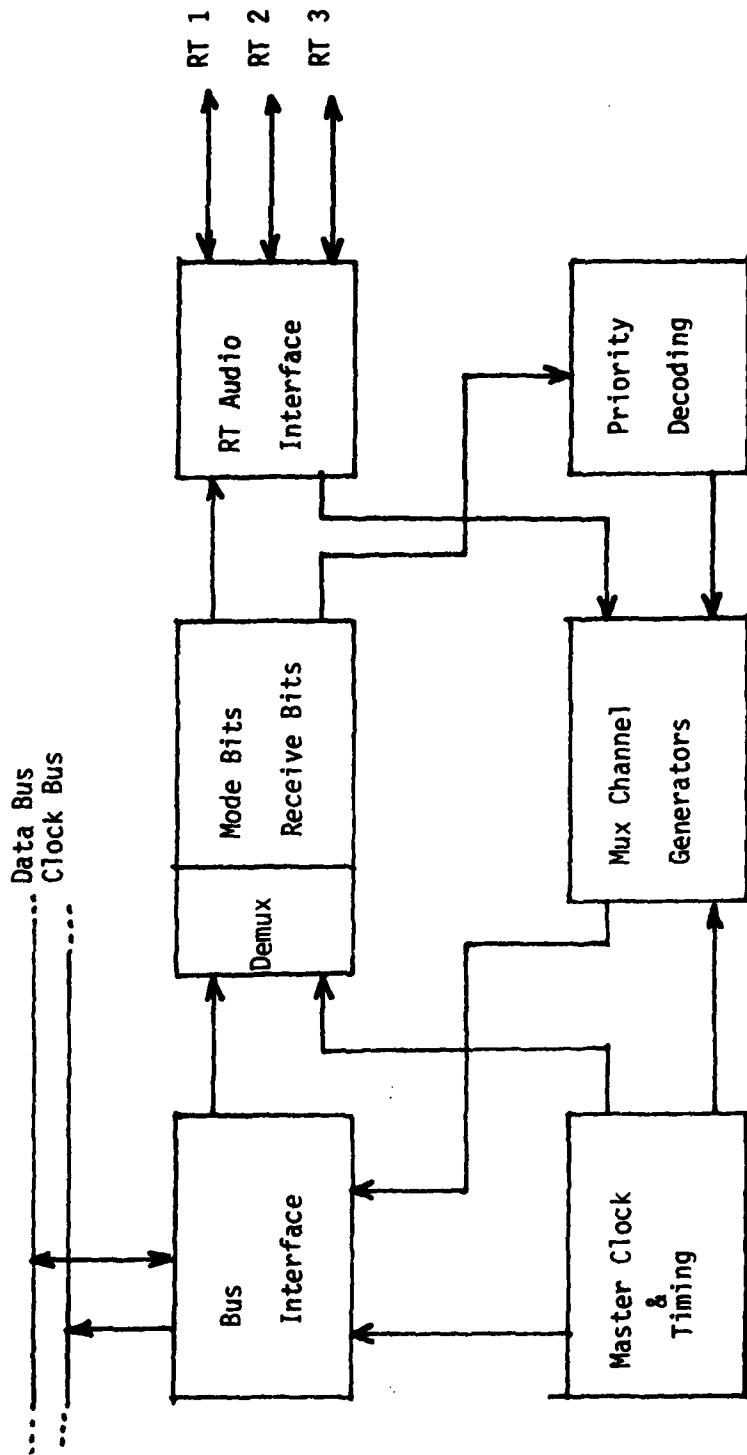
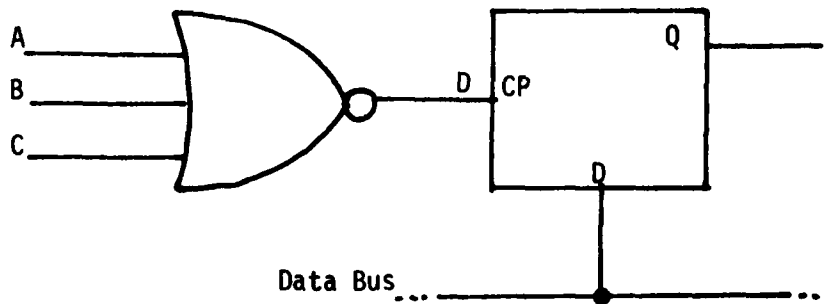
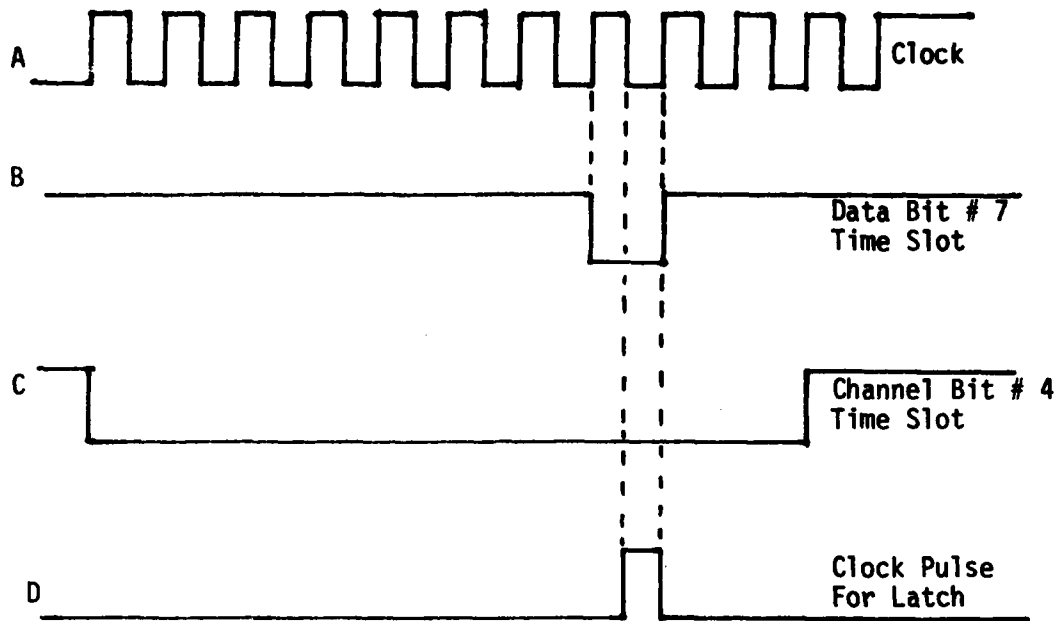

Figure 3 Controller Block Diagram



Q output is D-1 bit (bit #7) in CS-2 channel (channel #4), updated every frame (35 kHz rate)

Figure 4 Demultiplexing

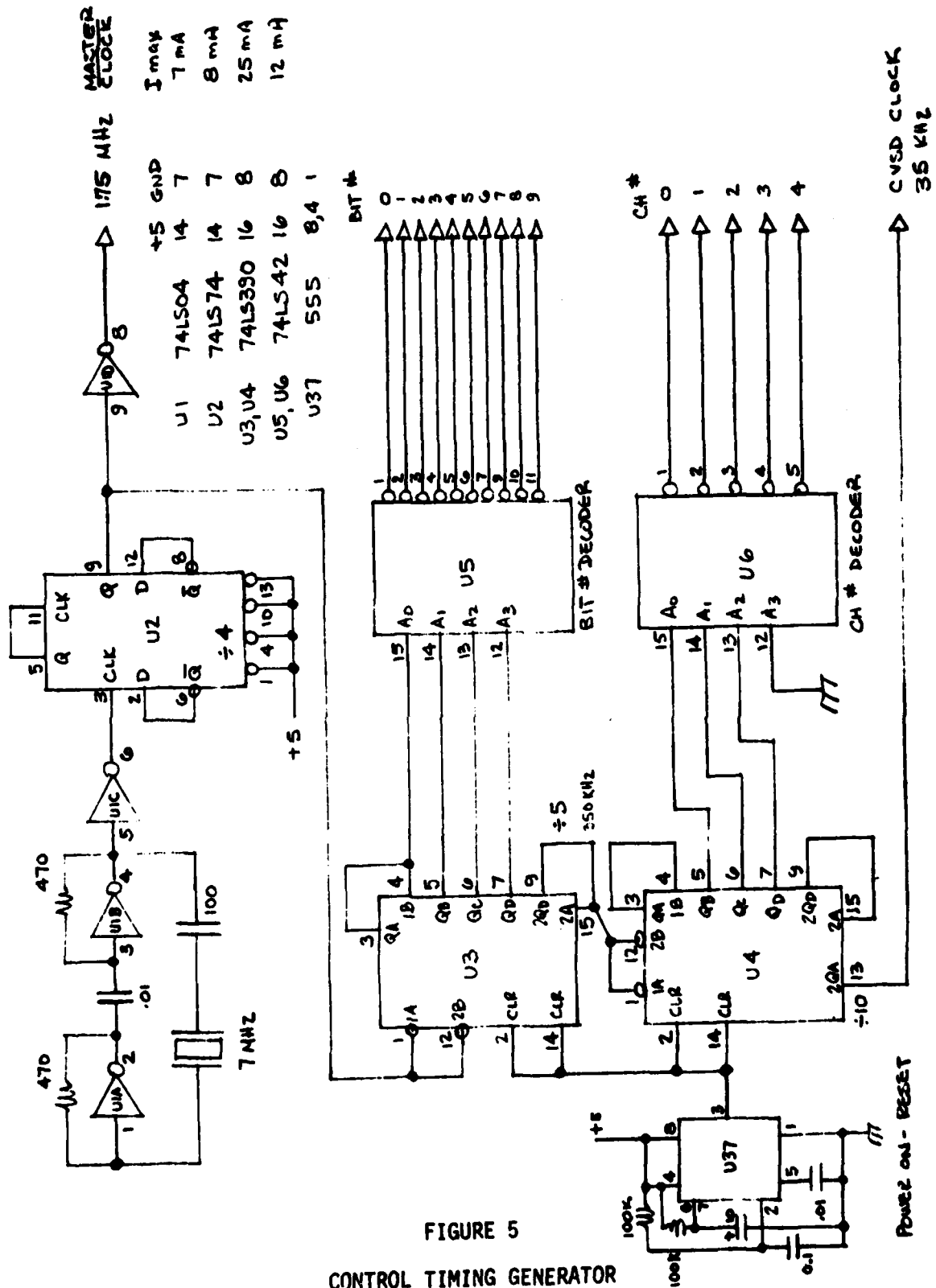

FIGURE 5  
CONTROL TIMING GENERATOR



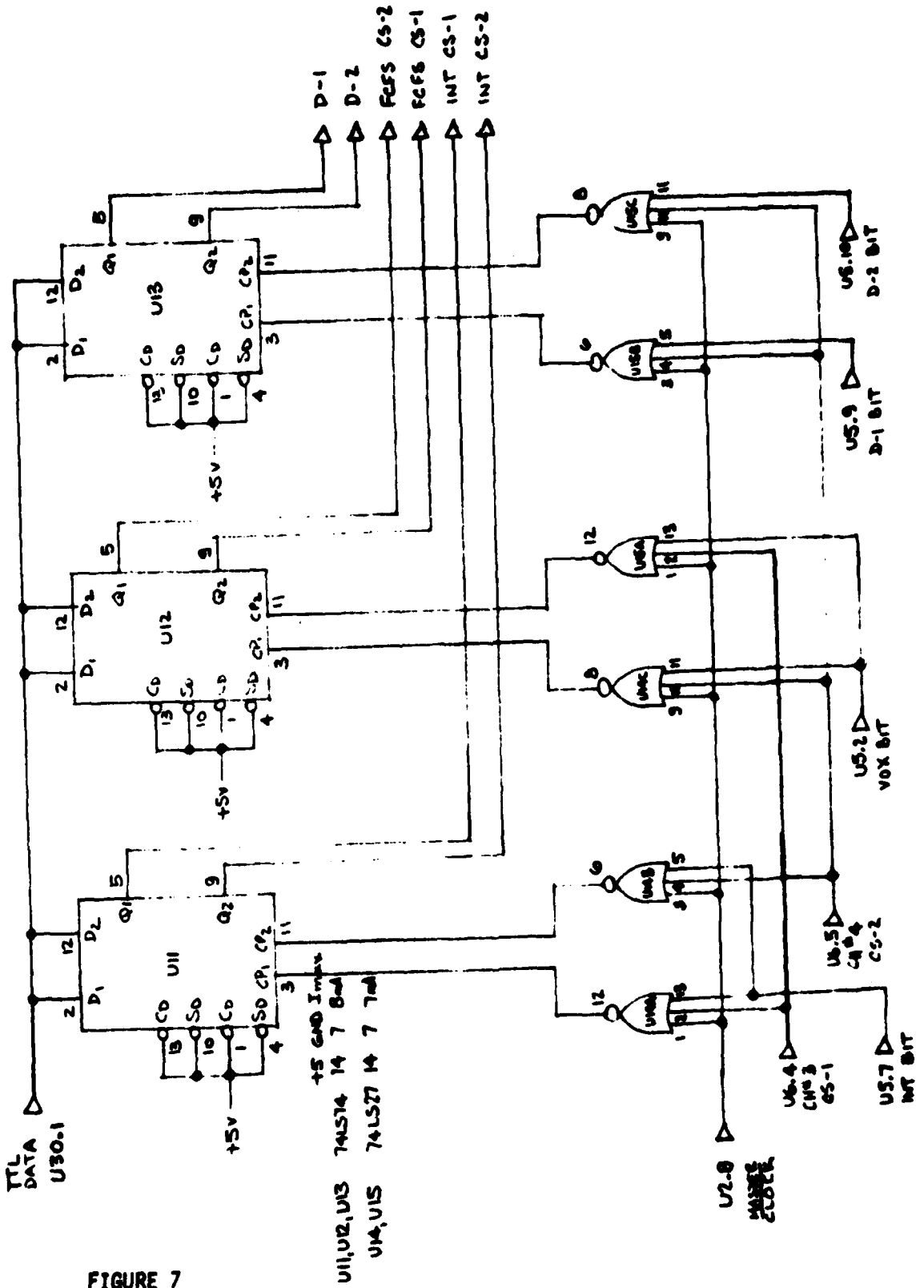

FIGURE 7

CONTROL RECEIVE LATCHES  
11







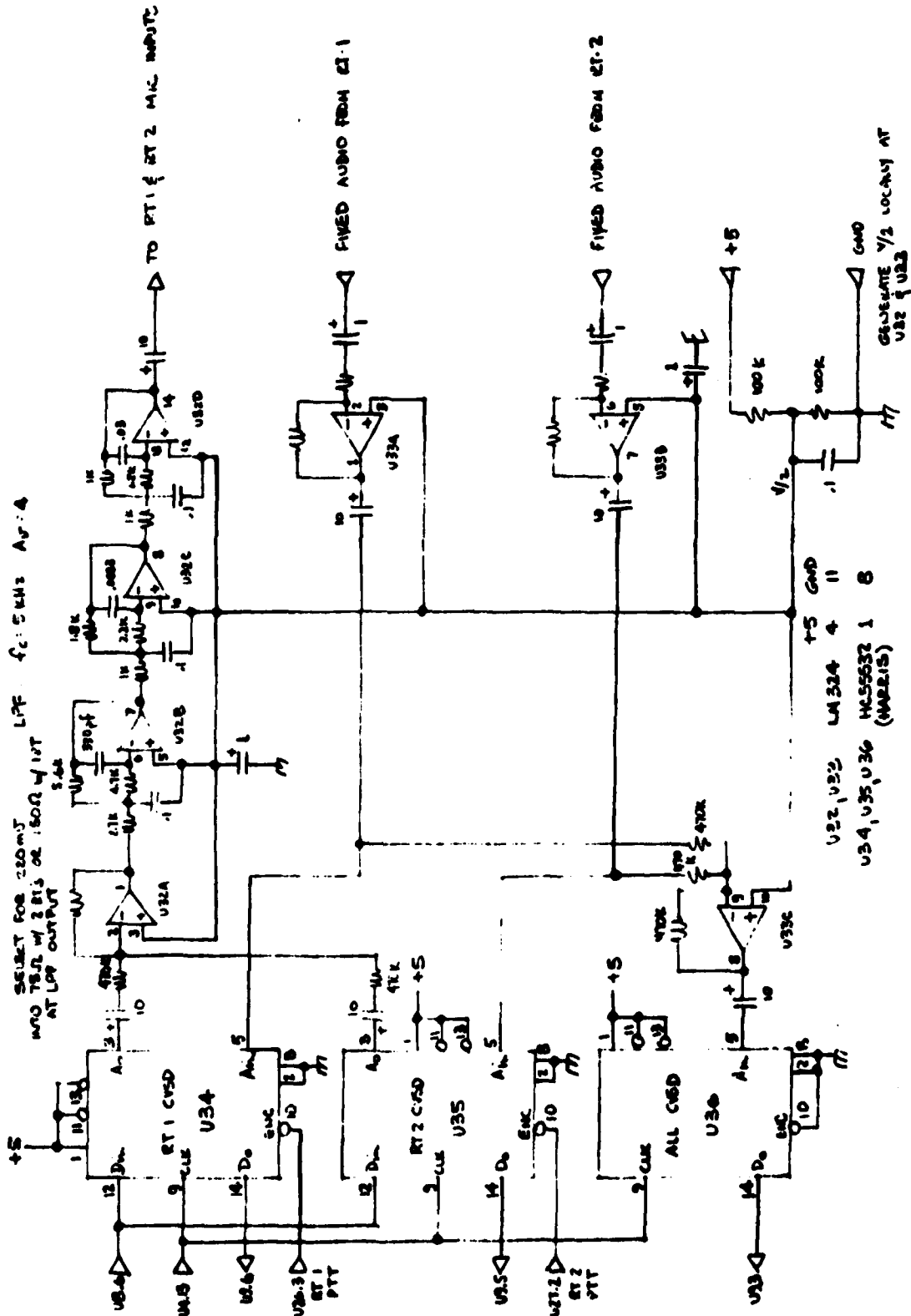

FIGURE 11 CONTROL STATION AUDIO  
 15

mode. Even if a non-accessed crew member were to try to speak, he would hear no side tone indicating that he did not have access to the intercom. He would, however, continue to monitor system activity.

Simultaneously the intercom CVSD output bit from the accessed crew member is latched by the controller and reapplied as one of the bits in the controller generated receive channel. All crew stations constantly monitor the intercom bit in the receive channel, and therefore, constantly monitor the station that has access to the system.

The other bits in the receive channel are digital outputs from CVSD's associated with each RT that is in the system. In this design 3 RT's can be interfaced to the system. There is a dedicated CVSD, with each RT, that is encoding (A-D) for receive mode monitoring and decoding (D-A) when an accessed crew member keys that RT. One additional CVSD is dedicated to constantly encoding (A-D) an analog mix of all RT receive audio. This is the ALL channel. With the present design of 3 RT's, there are still 3 bits unused in the receive channel. These bits could be used for addition of more RT's or for combinations of the first three RT's, i.e., 1 and 2, 2 and 3, and 1 and 3. Preprogramming combinations such as these, done in the controller, would eliminate the need for additional CVSD chips in each crew station in order to monitor particular combinations of multiple RT audio signals.

So far only transmission on the intercom has been discussed. When a crew member desires to key a radio, the presence of a key radio bit in the CS channel will be detected and latched in the controller by U23. In addition, U22 and U23 detect and latch 3 bits, the mode bits M1, M2 and M3, from either CS channel and when decoded by U24, determine which RT will be keyed. The presence of the key radio bit and the information that there is a speaker are used to enable the RT key decoder U24. This output keys the PTT for the selected RT and simultaneously enables the RT CVSD to a decode (D-A) mode in order to modulate the transmitter.

The sync channel is also generated by the controller and is simply a channel of all 1's (8 bits). With the present system configuration the probability of all 1's in any other channel is zero unless there are system bit errors and to date, there have been no problems encountered with false sync.

#### CREW STATION OPERATING DESCRIPTION (Figures 14-19)

The crew station block diagram is shown in Figure 12. The crew stations operate in party line fashion with all stations sharing the data and timing bus lines. The sync channel, generated by the controller, is detected by the crew station and used to reset the bit and channel time slot generators which are clocked from the timing bus. Since all crew stations operate from

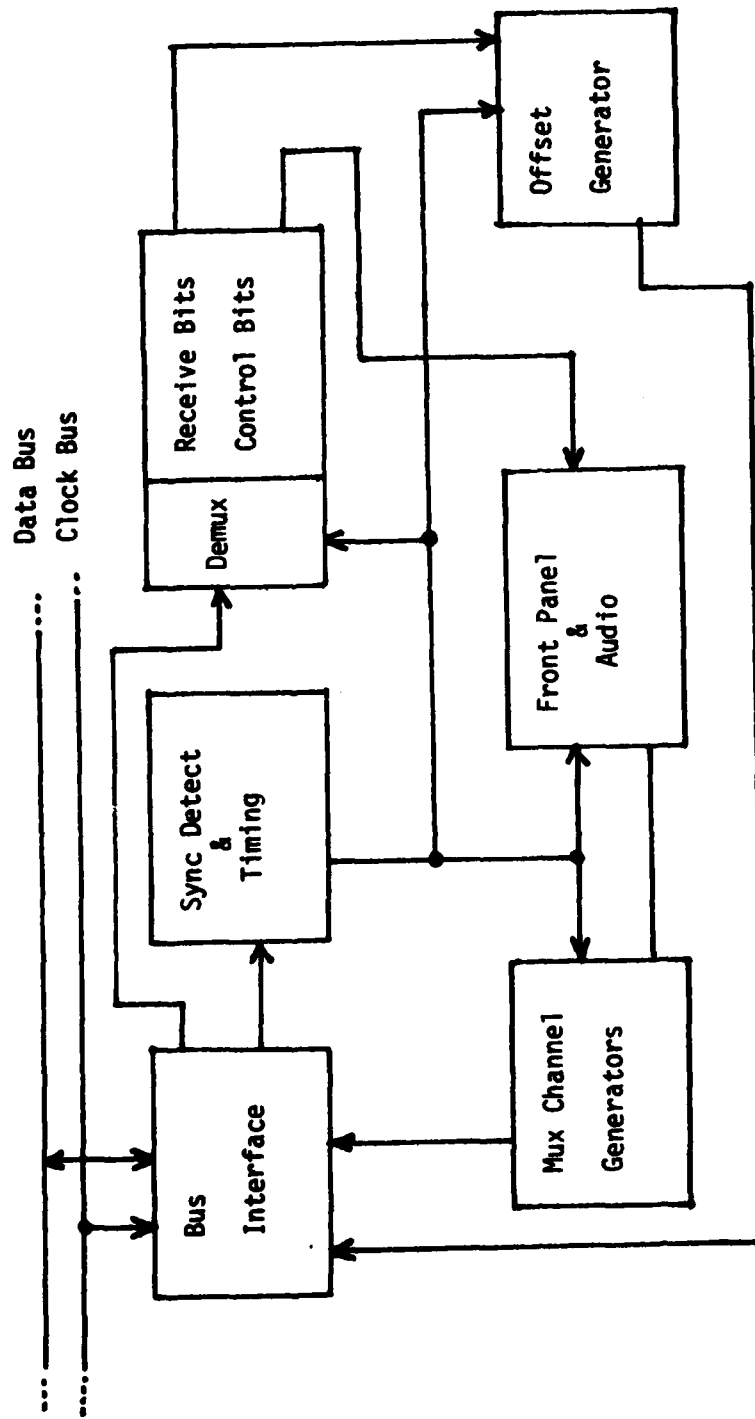

Figure 12 Crew Station Block Diagram

the party line, all stations detect sync simultaneously and, therefore, operate synchronously with the controller. To insure reliable operation, sync is sent in each frame. U5 is a presettable binary counter which is used as the sync detector. After 8 consecutive 1's are counted, a reset pulse is applied to the bit and channel time slot decoder network U6, U7, U8 and U9. Therefore, the crew stations define the beginning of the frame with the control channel. The difference in frame definition between control and crew station is shown in Figure 13. As in the controller, once all the bit and channel time slots are defined and synchronous with the controller, they are used for controlling demultiplexing (latching) data from the data bus and for controlling multiplexing data onto the data bus.

Once sync has been received and decoded, the crew stations must demultiplex information from two other channels. The control channel contains data bits which control crew station access to talk on the bus. The control channel is presently configured as follows: one bit to control the crew station in the CS-1 channel and four bits to control the four crew stations sharing the CS-2 channel. The presence of a bit in any particular time slot will inhibit (force the crew station CVSD to decode, D-A) that particular crew station from talking on the data bus. If an inhibited station attempts to talk on the bus, no sidetone will be heard since that CVSD is being held in a decode (D-A) mode.

Since there are up to four crew stations sharing the CS-2 channel in the present configuration, each crew station must take a turn in transmitting its data in the CS-2 channel slot. There can be a maximum of four stations sharing the channel so, each crew station must transmit its data once during four consecutive frames. Moreover, all CS-2 crew stations must be interleaved so as not to interfere with each other. If one of the CS-2 crew stations becomes the accessed crew station, the interleaving is stopped and that crew station will transmit its data in the CS-2 channel time slot every frame as if that station was the only CS-2 channel crew station. The interleaving is accomplished by an offset counter, U13, with the offset selected by an internal switch. Prior to system installation, each of the four CS-2 crew stations would have to be set, each with one of the four offsets. Referring to Figure 17, the offset generator functions as follows. The offset counter, U13, will count 1 to 4 times clocked by an input from the CS-2 channel time slot decoder. A four position switch will select which offset (1 thru 4) is desired for that particular crew station. Once that offset (count) has been reached, the output from U21B will gate off the input at U21A and enable a divide by 4 counter, U14, which in turn, will enable the line driver to output the CS-2 data on the data bus. The result is that a crew station set to position A will transmit data in the CS-2 channel during the first CS-2 interval; position B will allow data to be transmitted in the CS-2 channel during the next frame and so on until all four stations have been sequenced.

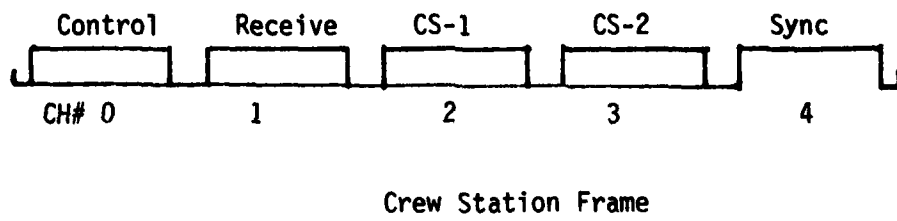
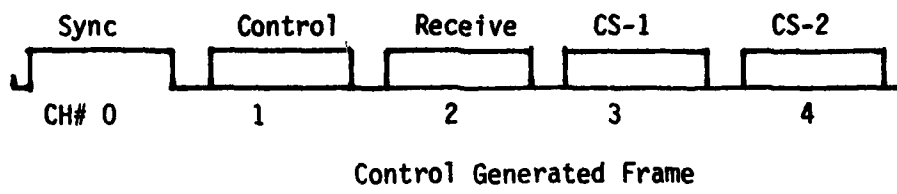

Figure 13 Frame Definition

U1	U2	U3,U4	+5V	GND	I MAX
75115	75113	74LS194	16	8	65 mA
			16	8	50 mA
			16	8	23 mA

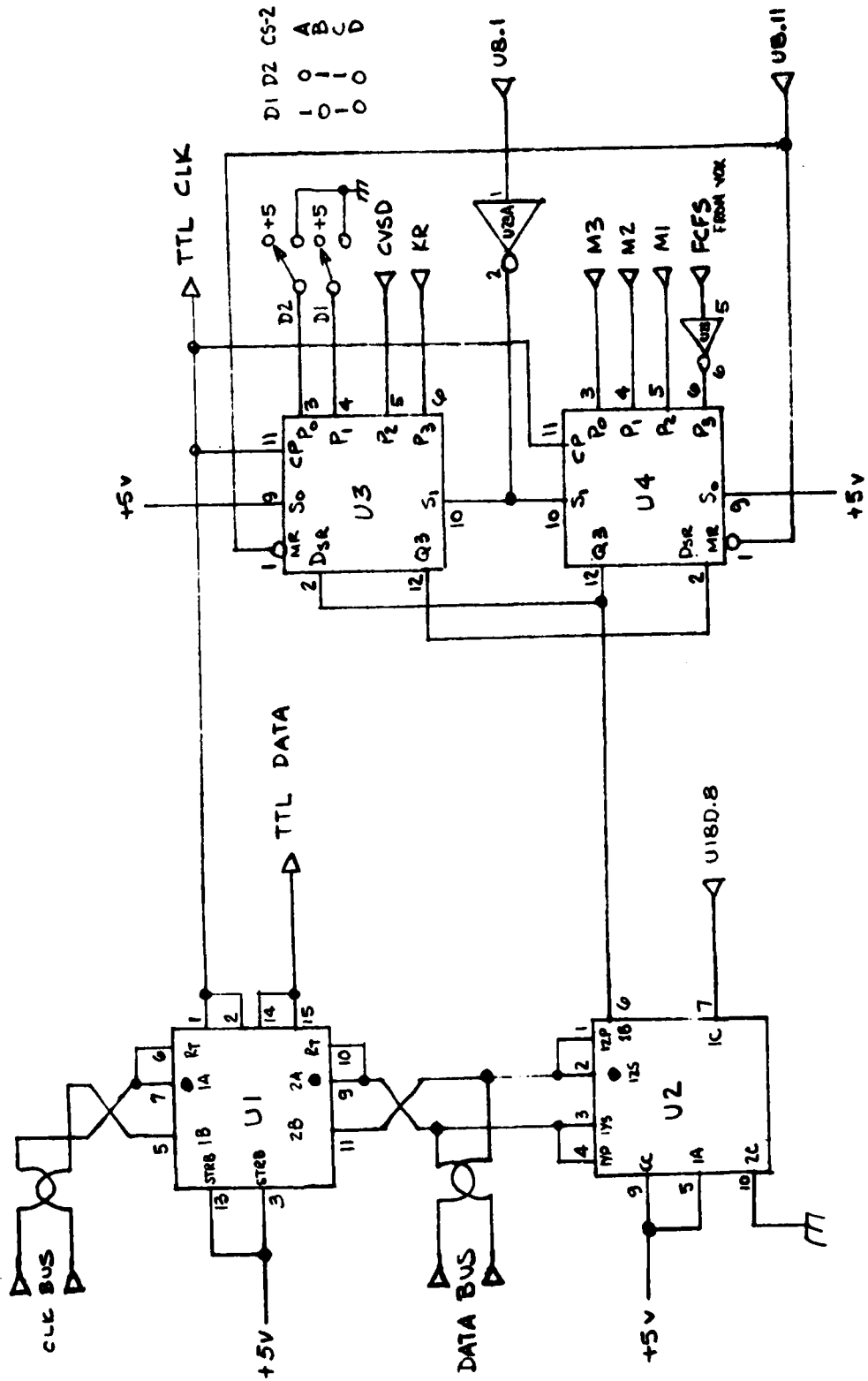

FIGURE 14 BUS INTERFACE  
20

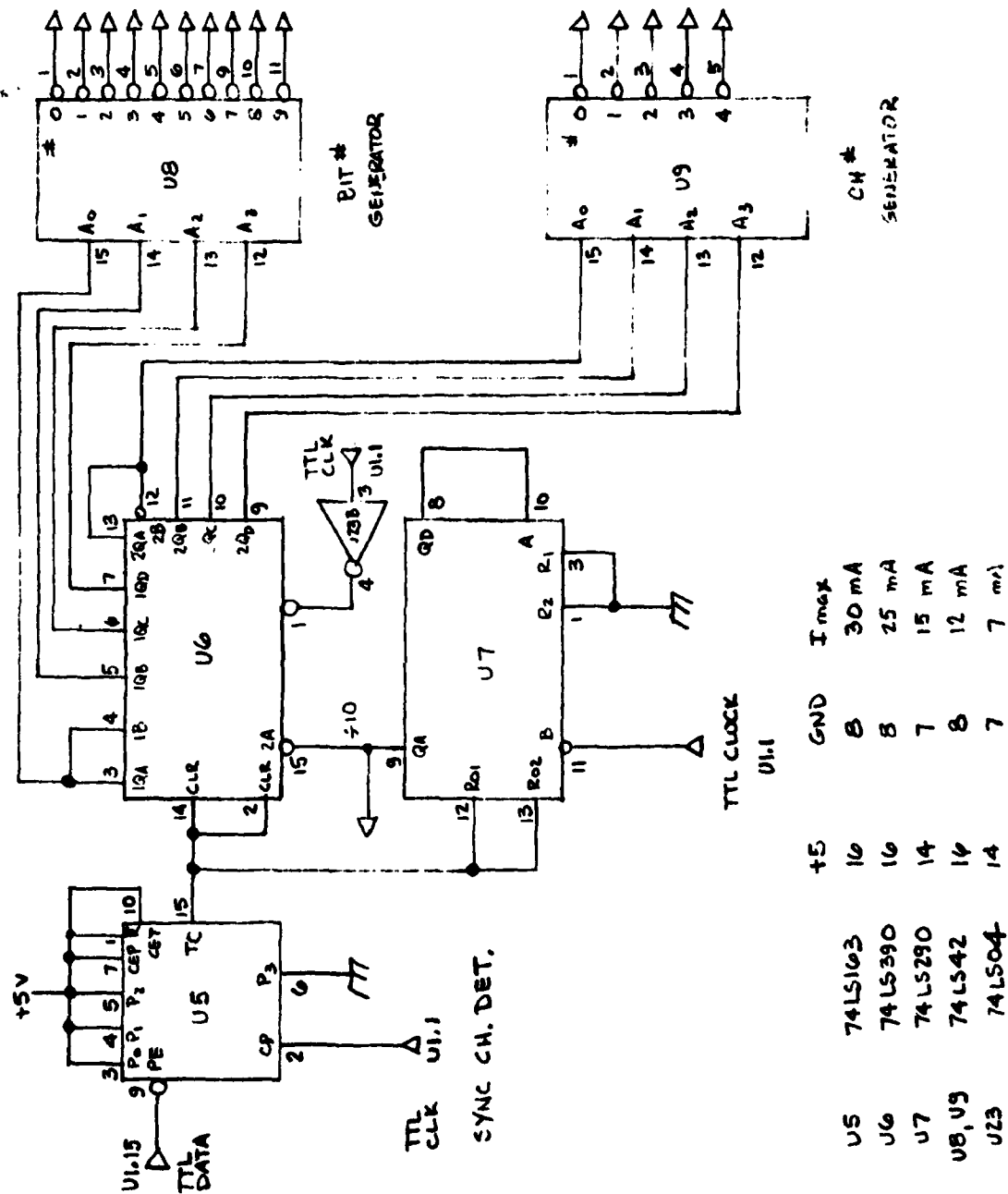

FIGURE 15  
TIMING GENERATOR

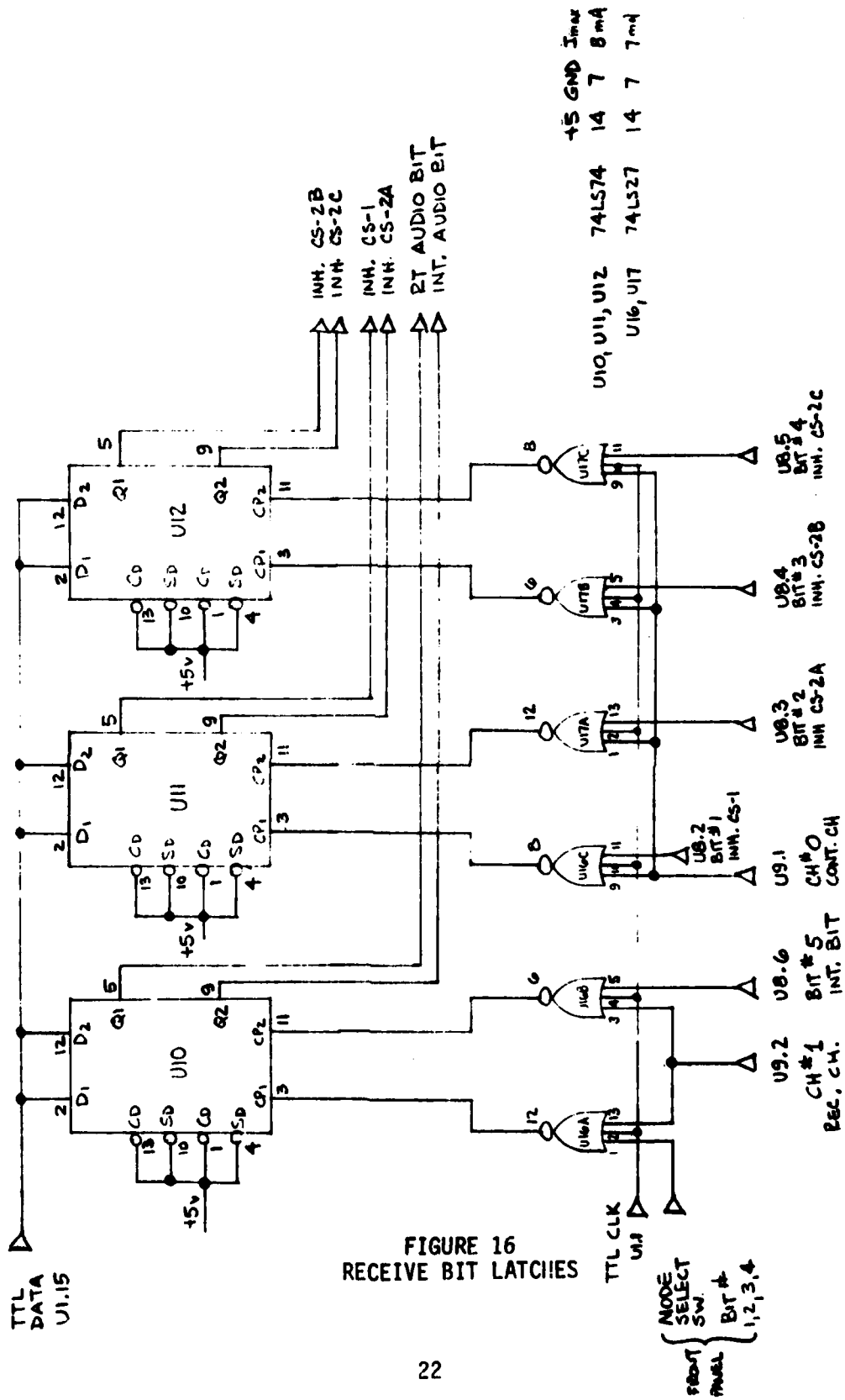

FIGURE 16  
RECEIVE BIT LATCHES

+5 GND Inver  
U10, U11, U12 74LS74 14 7 8 mA  
U16, U17 74LS27 14 7 7 mA

\* INH BITS NORMALLY HIGH



A	ALL	M1	M2	M3
B	RT1	0	1	0
C	RT2	1	0	0
D	RT3	0	1	1
E	INT ONLY	0	0	0

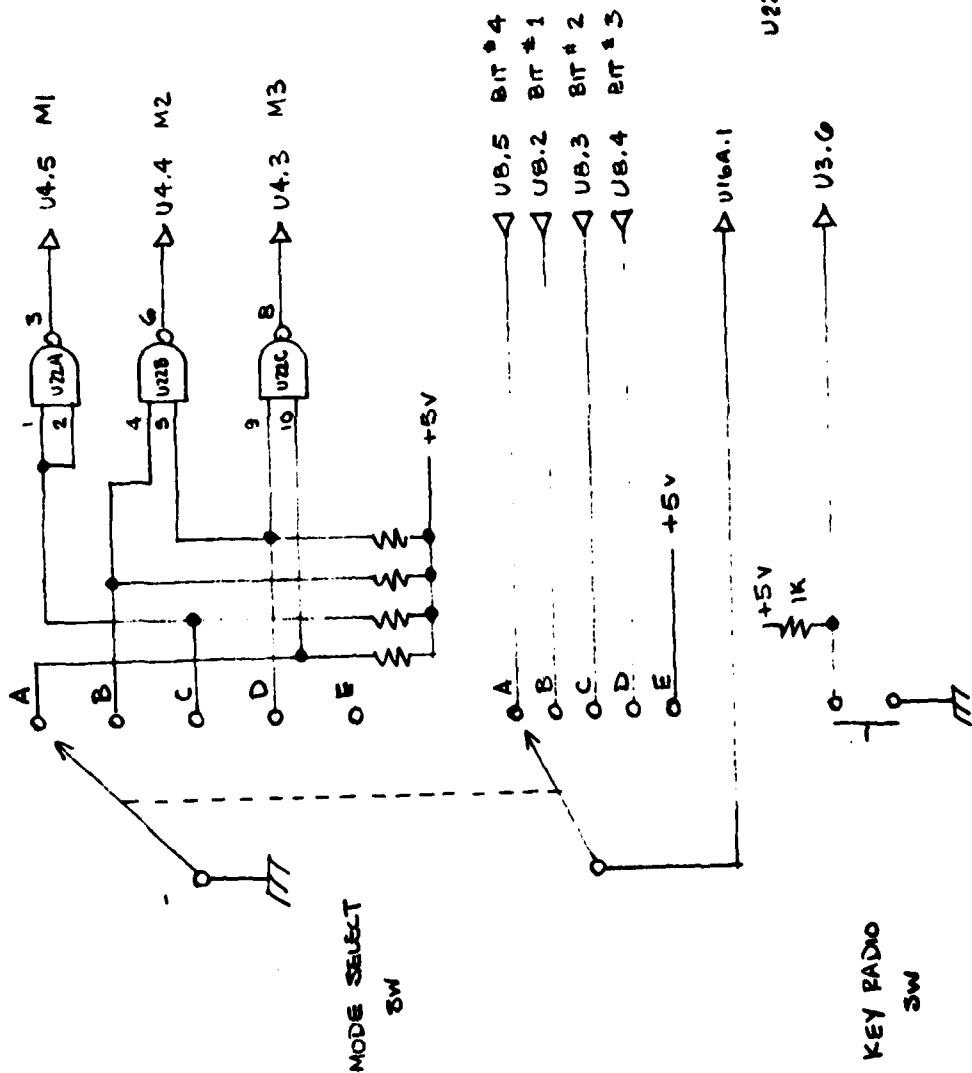

U22	74LS00	14	7	4mA
		+5	600	1mA

FIGURE 18 FRONT PANEL CONTROLS



If any CS-2 crew station is accessed, represented by any one of the four CS-2 inhibit bits in the control channel going low, the offset counter U-13 is reset and held reset while the station is accessed. The offset circuitry is then bypassed by means of the quad bilateral switch, U15, and the accessed crew station's line driver is enabled during every frame rather than every fourth frame. Once the station stops talking, that station's control bit in the control channel goes high again and all CS-2 offset counters become enabled again simultaneously. This allows the offset generator in each crew station to be synchronous and for the offsets to be properly interleaved.

The receive channel contains the CVSD output from the RT's and the intercom bit of the accessed crew station. All crew stations constantly monitor the intercom CVSD bit, but the radio CVSD bit monitored is controlled by the crew station mode switch. The demultiplexing of both bits is done by a dual latch, U10. The RT which is monitored is also the one which is modulated if the crew station enters the key radio mode. The RT selected by the crew station mode switch is coded by 3 bits, M1, M2 and M3. These bits are decoded in the controller and steer the PTT signal to the selected RT. The intercom is VOX operated, but in order to prevent accidental keying of an RT, a momentary contact push button is located on the crew station. This switch is essentially ANDed with the VOX output to generate a PTT. A deliberate action is required by the operator to key the radio but the modulation is under VOX control. Therefore, the key radio mode is activated by the presence of the key radio bit, controlled by the push button, and access to the data bus is controlled by VOX. In other words, simply pressing the key radio push button will not key the radio; the crew station must also have accessed the data bus as determined by sensing the VOX bit in the controller. Activating the key radio switch also lengthens the VOX release time for better radio message continuity with little or no on-off keyings during the transmission.

#### SUMMARY

The basic purpose of this work was to investigate the feasibility of the demand access concept. Although this type of operation is not normally associated with intercom systems, the advantage of this type of system is a design with fewer components, potentially better signal to noise ratio and lower cost. The prototype hardware was built and the feasibility was demonstrated successfully.

Obviously a key to this type of system is a good voice operated switch (VOX); one that is immune to ambient vehicular noise, and one that has suitable attack and release properties. The VOX used in the prototype equipment was a phase lock loop, noise insensitive design, which performed satisfactorily in both tank and APC field trials. This design, as well as others such as digital VOX for example, should be investigated in depth during any subsequent intercom program.

The work presented in this report in no way represents a desired or preferred approach to the VIS design. Rather, it is one idea with advantages and disadvantages which must be analyzed against other feasible approaches and matched against user requirements in order to design the next generation intercommunication system.

**APPENDIX A**

**ITT Aerospace/Optical Division Design Reports**

<b>Title</b>	<b>DTIC No.</b>
1. First Quarterly Report	ADA054021
2. Second Quarterly Report	ADA057277
3. Third Quarterly Report	ADA058584
4. Final Report	ADA071386

**Cincinnati Electronics Corporation**

<b>Title</b>	<b>DTIC No.</b>
1. First Quarterly Report	ADA052437
2. Second Quarterly Report	ADA058033
3. Third Quarterly Report	ADA060758
4. Final Report	ADA065058