

AD-A082 225

DAVID W TAYLOR NAVAL SHIP RESEARCH AND DEVELOPMENT CE--ETC F/G 20/3
THE MAGNETIC INDUCTION OF THE SYSTEM CONSISTING OF A FERROMAGNE--ETC(U)
FEB 80 F E BAKER, S H BROWN
DTNSRDC-80/041

UNCLASSIFIED

NL

[or]
ALL
AD-A082 225



END
DATE
FILMED
4-80
DTIC

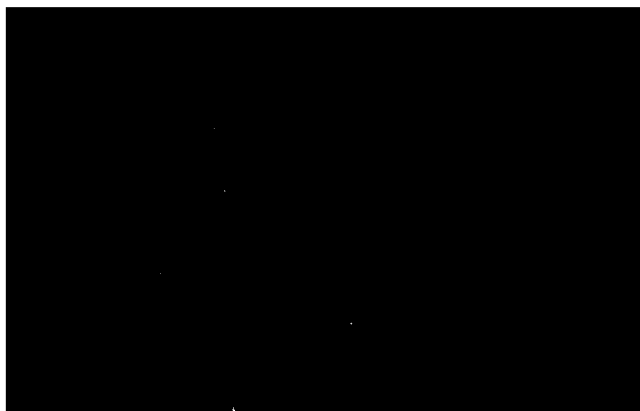

UNCLASSIFIED

SECURITY CLASSIFICATION OF THIS PAGE (When Data Entered)

REPORT DOCUMENTATION PAGE		READ INSTRUCTIONS BEFORE COMPLETING FORM	
1. REPORT NUMBER DTNSRDC-86/841	2. GOVT ACCESSION NO.	3. RECIPIENT'S CATALOG NUMBER	
4. TITLE (and Subtitle) THE MAGNETIC INDUCTION OF THE SYSTEM CONSISTING OF A FERROMAGNETIC PROLATE SPHEROIDAL SHELL WITH INTERNAL AND EXTERNAL INFINITESIMALLY THIN PROLATE SPHEROIDAL CURRENT BANDS		5. TYPE OF REPORT & PERIOD COVERED Research and Development	
7. AUTHOR(s) F. Edward/Baker and Samuel H./Brown		6. PERFORMING ORG. REPORT NUMBER	
9. PERFORMING ORGANIZATION NAME AND ADDRESS David W. Taylor Naval Ship R&D Center Annapolis, Maryland 21402		8. CONTRACT OR GRANT NUMBER(s) (12) 1A1	
11. CONTROLLING OFFICE NAME AND ADDRESS David W. Taylor Naval Ship R&D Center Bethesda, Maryland 20084		10. PROGRAM ELEMENT, PROJECT, TASK AREA & WORK UNIT NUMBERS Program Element 11221N Task Area B0005-SL-001 Work Unit 1-2704-110	
14. MONITORING AGENCY NAME & ADDRESS (if different from Controlling Office) (11) B005SL001		12. REPORT DATE February 1986	
		13. NUMBER OF PAGES 61	
		15. SECURITY CLASS. (of this report) UNCLASSIFIED	
		15a. DECLASSIFICATION/DOWNGRADING SCHEDULE	
16. DISTRIBUTION STATEMENT (of this Report) APPROVED FOR PUBLIC RELEASE; DISTRIBUTION UNLIMITED. (16) P005SL1			
17. DISTRIBUTION STATEMENT (of the abstract entered in Block 20, if different from Report)			
18. SUPPLEMENTARY NOTES			
19. KEY WORDS (Continue on reverse side if necessary and identify by block number) Electromagnetic Fields Magnetic Induction Induction Ferromagnetism			
20. ABSTRACT (Continue on reverse side if necessary and identify by block number) The magnetic induction is calculated for the configuration consisting of a ferromagnetic prolate spheroidal shell with internal and external infinitesimally thin prolate spheroidal current bands. The ferromagnetic body is assumed to be linear and homogeneous. The reduction of the solutions to that of a prolate spheroidal current band in free space is shown when the permeability of the ferromagnetic prolate spheroidal shell is allowed to approach that of free space and when either the current in the internal or external prolate spheroidal band is set equal to zero.			

DD FORM 1 JAN 73 1473

EDITION OF 1 NOV 65 IS OBSOLETE
S/N 0102-014-6601

UNCLASSIFIED

SECURITY CLASSIFICATION OF THIS PAGE (When Data Entered)

SECURITY CLASSIFICATION OF THIS PAGE(When Data Entered)

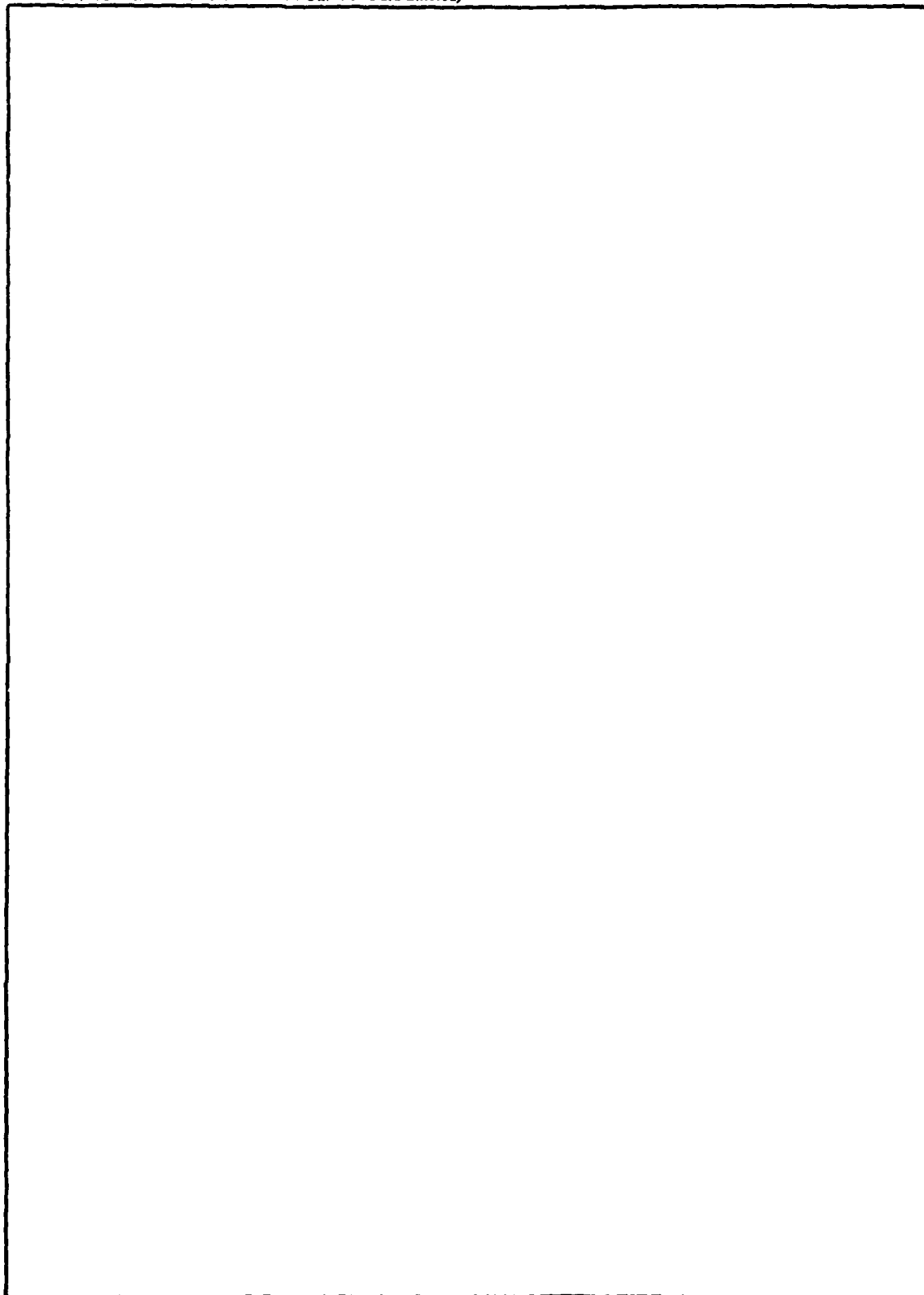

SECURITY CLASSIFICATION OF THIS PAGE(When Data Entered)

TABLE OF CONTENTS

	Page
LIST OF FIGURES.	iv
NOMENCLATURE	v
EXECUTIVE SUMMARY.	x
OBJECTIVE	x
APPROACH.	x
RESULTS	x
RECOMMENDATIONS	x
ABSTRACT	1
ADMINISTRATIVE INFORMATION	1
INTRODUCTION	1
PROLATE SPHEROIDAL COORDINATE SYSTEM	2
BASIC EQUATIONS.	3
FERROMAGNETIC PROLATE SPHEROIDAL SHELL WITH INTERNAL AND EXTERNAL, INFINITESIMALLY THIN, PROLATE SPHEROIDAL CURRENT BANDS	6
GENERAL SOLUTION.	6
BOUNDARY CONDITIONS	11
APPENDIX A - DERIVATION OF COEFFICIENTS OF THE VECTOR POTENTIAL FOR A FERROMAGNETIC PROLATE SPHEROIDAL SHELL WITH INTERNAL AND EXTERNAL, INFINITESIMALLY THIN, PROLATE SPHEROIDAL CURRENT BANDS.	25
APPENDIX B - DETERMINATION OF THE MAGNETIC VECTOR POTENTIAL FOR AN INFINITESIMALLY THIN PROLATE SPHEROIDAL CURRENT BAND.	37
APPENDIX C - REDUCTION OF THE MAGNETIC VECTOR POTENTIAL FOR A FERROMAGNETIC PROLATE SPHEROIDAL SHELL, SURROUNDING AND SURROUNDED BY INFINITESIMALLY THIN CURRENT BANDS, TO THAT OF A THIN COIL IN FREE SPACE WHEN THE INTERNAL CURRENT DENSITY $[J_1(\theta)]$ IS ZERO AND IN THE LIMIT μ_2 EQUALS μ_1	41

	Page
APPENDIX D - REDUCTION OF THE MAGNETIC VECTOR POTENTIAL FOR A FERROMAGNETIC PROLATE SPHEROIDAL SHELL, SURROUNDING AND SURROUNDED BY INFINITESIMALLY THIN CURRENT BANDS, TO THAT OF A THIN COIL IN FREE SPACE WHEN THE EXTERNAL CURRENT DENSITY $[J_2(\theta)]$ IS ZERO AND IN THE LIMIT μ_2 EQUALS μ_1	51
REFERENCES.	59

LIST OF FIGURES

1 - Prolate Spheroidal Coordinate System.	2
2 - Cross Section of Ferromagnetic Spheroidal Shell Surrounding and Surrounded by Infinitesimally Thin Current Bands.	7
B.1 - Infinitesimally Thin Spheroidal Current Band.	37

NOMENCLATURE

\bar{A}	Vector potential function
A_{ψ}	Psi (ψ) component of \bar{A}
$A_{\psi I}$	Psi component of \bar{A} in Region I
$A_{\psi II}$	Psi component of \bar{A} in Region II
$A_{\psi III}$	Psi component of \bar{A} in Region III
$A_{\psi IV}$	Psi component of \bar{A} in Region IV
$A_{\psi V}$	Psi component of \bar{A} in Region V
\bar{B}	Magnetic flux density or magnetic induction
\bar{B}_1	Magnetic flux density in Medium I
\bar{B}_2	Magnetic flux density in Medium II
B_{η}	Eta component of the magnetic flux density
B_{θ}	Theta component of the magnetic flux density
$B_{\eta I}$	Eta component of \bar{B} in Region I
$B_{\eta II}$	Eta component of \bar{B} in Region II
$B_{\eta III}$	Eta component of \bar{B} in Region III
$B_{\eta IV}$	Eta component of \bar{B} in Region IV
$B_{\eta V}$	Eta component of \bar{B} in Region V
B_{n1}	Normal component of \bar{B} in Medium 1
B_{n2}	Normal component of \bar{B} in Medium 2
\bar{H}	Magnetic field intensity

A

\bar{H}_1	Magnetic field intensity in Medium 1
\bar{H}_2	Magnetic field intensity in Medium 2
H_{t1}	Tangential component of H in Medium 1
H_{t2}	Tangential component of H in Medium 2
\bar{J}	Electric current density
\bar{J}_1	Electric current density of internal current band
\bar{J}_2	Electric current density of external current band
J_1	Magnitude of \bar{J}_1
J_2	Magnitude of \bar{J}_2
J_η	Eta component of J
J_θ	Theta component of J
J_ψ	Psi component of J
\bar{J}_s	Surface current density
J	Magnitude of \bar{J}_s
χ_m	Magnetic susceptibility
μ	Magnetic permeability
μ_r	Relative magnetic permeability
μ_0	Permeability of free space
μ_1	Permeability
μ_2	Permeability
\bar{n}_{12}	Unit vector normal to interface; directed from Medium 1 into Medium 2

x, y, z	Rectangular coordinates
η, θ, ψ	Prolate spheroidal coordinates
\bar{e}_η	Unit normal vector in eta direction
\bar{e}_θ	Unit normal vector in theta direction
\bar{e}_ψ	Unit normal vector in azimuthal direction
$\bar{\nabla} \cdot$	Divergence operator
$\bar{\nabla} \times$	Curl operator
∇^2	Scalar Laplacian operation
$\nabla^2 \bar{A}$	Vector Laplacian operation
p	Integer from one to infinity
$P_p^m(\cos \theta)$	Associated Legendre function of the first kind
$Q_p^m(\cos \theta)$	Associated Legendre function of the second kind
$\nabla^2 \bar{A}_\psi$	Psi vector component of the vector Laplacian of \bar{A} in prolate spheroidal coordinates
$(\bar{\nabla} \times \bar{A})_\eta$	Eta component of the curl \bar{A}
$(\bar{\nabla} \times \bar{A})_\theta$	Theta component of the curl \bar{A}
θ_1, θ_2	Angles describing the limits of the internal current band, $J_1(\theta)$
θ'_1, θ'_2	Angles describing the limits of the external current band, $J_2(\theta)$
$\eta_1, \eta_2, \eta_3, \eta_4$	Constants
A_p, B_p, C_p	} Constants in the general solution of \bar{A} where $p = 1$ to ∞
D_p, E_p, F_p	
G_p, H_p	

ξ	Variable equal to $\cosh \eta$
v	Variable equal to $\cos \theta$
e_1, e_2, e_3	Metric coefficients for a prolate spheroidal coordinate system
p_p^Δ	Variable used for simplification
Q_p^Δ	Variable used for simplification
C_1, C_2	Constants
C_3, C_4	Constants
K_1, K_2	Constants
A, B	Constants
A', B'	Constants
V_p, U_p	Constants in current expansion where $p = 1$ to ∞

A_ψ Psi component of the vector Laplacian of \bar{A} in prolate spheroidal coordinate

$$= \frac{(\sinh^2 \eta + \sin^2 \theta)^{-\frac{1}{2}}}{a^2 (\sinh \eta \sin \theta)} \left(\frac{\partial}{\partial \eta} \frac{1}{\sinh} \frac{\partial}{\partial \eta} (\sinh \eta A_\psi) \right) + \frac{\partial}{\partial \theta} \frac{1}{\sin \theta} \frac{\partial}{\partial \theta} (\sin \theta A_\psi)$$

$\nabla_{\psi} \bar{A}$ Vector Laplacian of \bar{A} in prolate spheroidal coordinates

$$= \frac{(\sinh^2 \eta + \sin^2 \theta)^{-1/2}}{a^2 (\sinh \eta \sin \theta)} \bar{e}_{\psi} \left(\frac{\partial}{\partial \eta} \frac{1}{\sinh} \frac{\partial}{\partial \eta} (\sinh \eta A_{\psi}) \right)$$

$$+ \frac{\partial}{\partial \theta} \frac{1}{\sin \theta} \frac{\partial}{\partial \theta} (\sin \theta A_{\psi})$$

EXECUTIVE SUMMARY

OBJECTIVE

The objective of this work was to derive the solution to a static ferromagnetic problem that included both current-carrying coils and linear ferromagnetic bodies. The solution is intended for comparison with the solution to the ferromagnetic problem obtained by various numerical techniques such as the finite difference method, the finite element method and the integral equation iterative solution method.

APPROACH

After deriving the governing differential equation from Maxwell's equations for classical magnetostatic field theory, the method of separation of variables was employed to obtain the problem solution.

RESULTS

The magnetic induction was calculated for a geometry consisting of a ferromagnetic prolate spheroidal shell and with a current-carrying conductor both internal and external to the shell. The ferromagnetic body was assumed to be linear and homogeneous. The reduction of the solutions to that of a prolate spheroidal current band in free space is shown when the permeability of the ferromagnetic prolate spheroidal shell is allowed to approach that of free space and when the current in the internal or external prolate spheroidal band is set equal to zero.

RECOMMENDATIONS

It is recommended that the derived solution be programmed on a digital computer for direct comparison of these results to those obtained by various numerical methods. There are plans to implement these recommendations during Fiscal Years 1980 and 1981.

ABSTRACT

The magnetic induction is calculated for the configuration consisting of a ferromagnetic prolate spheroidal shell with internal and external infinitesimally thin prolate spheroidal current bands. The ferromagnetic body is assumed to be linear and homogeneous. The reduction of the solutions to that of a prolate spheroidal current band in free space is shown when the permeability of the ferromagnetic prolate spheroidal shell is allowed to approach that of free space and when the current in the internal or external prolate spheroidal band is set equal to zero.

ADMINISTRATIVE INFORMATION

This work was performed under Program Element 11221N, Project B005, Task Area B0005-SL001, Work Unit 1-2704-110. The Project Director is Mr. W. J. Andahazy, David W. Taylor Naval Ship Research and Development Center.

INTRODUCTION

As reported previously,^{1,2*} exact analytical solutions of Maxwell's equations using classical formulations have been limited to body shapes and inhomogeneities that conform to a few separable coordinate systems. The large computational and storage capabilities of modern computers permit many electromagnetic field problems to be solved by using a numerical solution to the governing differential or integral equations under a suitable choice of boundary conditions. The numerical solutions of Maxwell's equations, when used with a complete description of the electric and magnetic sources and the constitutive laws of the media, can be used to describe completely the electric and magnetic fields produced by the source, including nonsymmetric geometries, nonsymmetric source distributions, and spatially varying media parameters.

The motivation for this work arose out of the need for solutions to static ferromagnetic problems that could be used for comparison with numerical methods.

*A complete list of references appears on page 59.

PROLATE SPHEROIDAL COORDINATE SYSTEM

The prolate spheroidal coordinate system can be formed by rotating the two-dimensional elliptic coordinate system, whose traces in a plane are confocal ellipses and hyperbolas, about the major axis of the ellipses.^{3,4}

Flammer⁴ notes that it is customary to make the z-axis the axis of revolution. Figure 1 depicts the three-dimensional prolate spheroidal coordinate system.

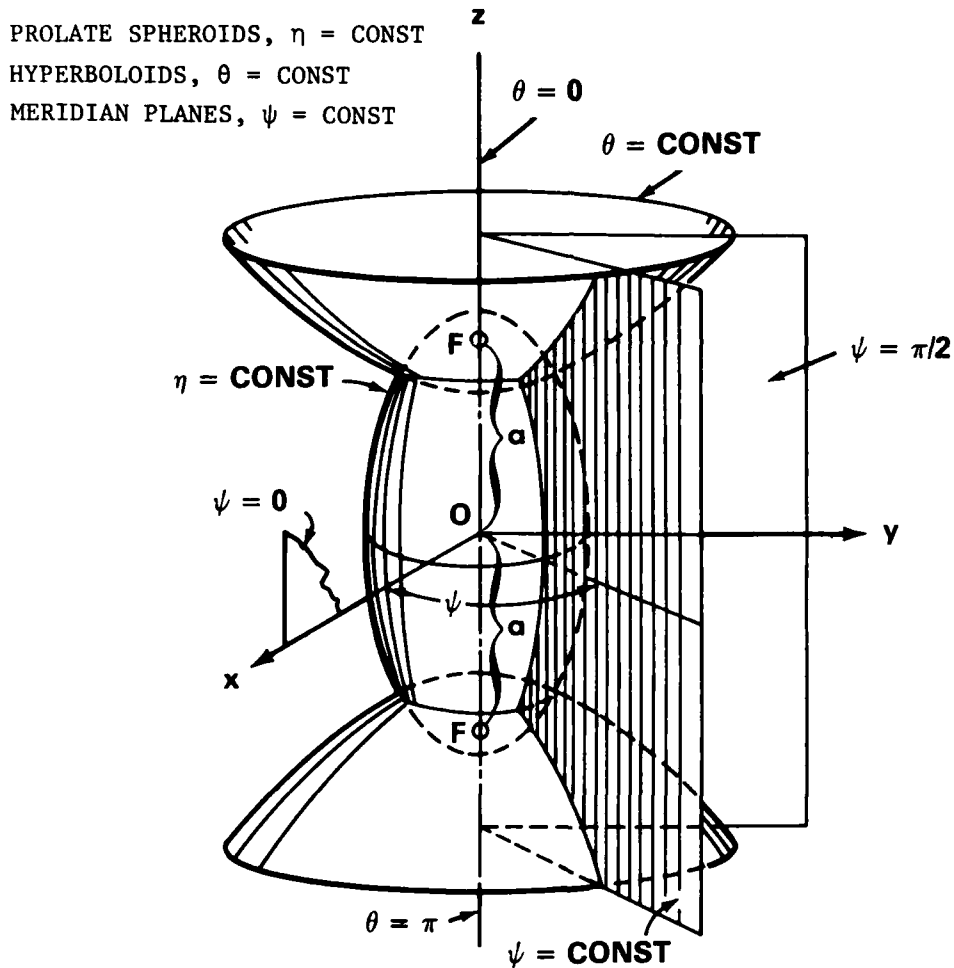

Figure 1 - Prolate Spheroidal Coordinate System

In this case, the coordinate surfaces are: prolate spheroids for $\eta =$ constant; hyperboloids of two sheets for $\theta =$ constant; meridian planes for $\psi =$ constant. The prolate spheroidal coordinates shown in Figure 1 are related to rectangular coordinates by the following transformation equations:

$$\begin{aligned}x &= a \sinh \eta \sin \theta \cos \psi \\y &= a \sinh \eta \sin \theta \sin \psi \\z &= a \cosh \eta \cos \theta\end{aligned}\tag{1}$$

where

$$0 \leq \eta \leq \infty$$

$$0 \leq \theta \leq \pi$$

$$0 \leq \psi \leq 2\pi$$

We have denoted the interfocal distance by $2a$ and the prolate spheroidal coordinates by (η, θ, ψ) .

BASIC EQUATIONS

We can start with Maxwell's equations for classical magnetostatic field problems

$$\bar{\nabla} \times \bar{H} = \bar{J}\tag{2a)*}$$

$$\bar{\nabla} \cdot \bar{B} = 0\tag{2b)}$$

where

\bar{H} = Magnetic field intensity (A/m)

\bar{B} = Magnetic flux density (T or Wb/m²)

\bar{J} = Electric current density (A/m²).

*The del operation, $\bar{\nabla}$, is defined with respect to the rectangular coordinate system and is strictly valid in a rectangular coordinate system only. Very often, $\bar{\nabla} \times$ and $\bar{\nabla} \cdot$ are used as equivalent symbols for curl and divergence generally. This use is followed in this report.

In the general case for ferromagnetic materials, \bar{B} is a nonlinear function, \bar{H}

$$\bar{B} = f(\bar{H}) \quad (3)$$

where \bar{B} is not a single valued function of \bar{H} . The function $f(\bar{H})$ depends on the magnetic history of the material; that is, how the material attained its magnetization. This is referred to as hysteresis. It is also noted that any property of a ferromagnetic material has meaning only if it is considered together with its complete magnetic history.

In certain practical engineering problems, the variation in the magnetic intensity is small, and the functional relationship between \bar{B} and \bar{H} is approximately linear.¹ For the linear case where the material is isotropic, the magnetic induction, \bar{B} , is related to the field intensity, \bar{H} , by the relationship

$$\bar{B} = \mu_0 (\chi_m + 1) \bar{H} = \mu_0 \mu_r \bar{H} = \mu \bar{H} \quad (4)$$

where

χ_m = Magnetic susceptibility (dimensionless)

μ = Magnetic permeability (H/m)

$(\chi_m + 1) = \mu_r$ = Relative permeability (dimensionless)

μ_0 = Free space permeability ($4\pi \times 10^{-7}$ H/m).

This report assumes that the ferromagnetic body has isotropic and linear material properties. The divergenceless nature of the magnetic flux density in conjunction with the fact that the divergence of the curl of any vector function is zero allows the introduction of the magnetic vector potential field \bar{A} ,

$$\bar{B} = \bar{\nabla} \times \bar{A} \quad (5)$$

where \bar{A} is the magnetostatic vector potential function in Wb/m. The substitution of Equation (5) into Equation (2a) gives the fundamental equation of the vector potential of the magnetostatic field.

$$\frac{1}{\mu} \bar{\nabla} \times (\bar{\nabla} \times \bar{A}) - (\bar{\nabla} \times \bar{A}) \times \bar{\nabla} \frac{1}{\mu} = \bar{J} \quad (6)$$

For homogeneous materials, as assumed in this report, the magnetic permeability is spatially invariant. Hence,

$$\bar{\nabla} \frac{1}{\mu} = 0 \quad (7)$$

and Equation (6) reduces to

$$\bar{\nabla} \times (\bar{\nabla} \times \bar{A}) = \mu \bar{J} \quad (8)$$

Using the vector identity

$$\bar{\nabla} \times \bar{\nabla} \times \bar{A} = \bar{\nabla} (\bar{\nabla} \cdot \bar{A}) - \nabla^2 \bar{A} \quad (9)$$

Equation (8) becomes

$$\bar{\nabla} (\bar{\nabla} \cdot \bar{A}) - \nabla^2 \bar{A} = \mu \bar{J} \quad (10)$$

The magnetic vector potential is characterized by the important property that its divergence can be conveniently chosen to be zero.

$$\bar{\nabla} \cdot \bar{A} = 0 \quad (11)$$

Equation (10) reduces to the vector's Poisson's differential equation.

$$\nabla^2 \bar{A} = -\mu \bar{J} \quad (12)$$

This is the governing equation for our calculations.

The general boundary conditions to be satisfied at the interfaces of stationary dissimilar media may be derived from the limiting integral forms of Maxwell's equations and are given by

$$\bar{n}_{12} \cdot (\bar{B}_2 - \bar{B}_1) = 0 \text{ or } B_{n1} = B_{n2} \quad (13a)$$

$$\bar{n}_{12} \times (\bar{H}_2 - \bar{H}_1) = \bar{J}_s \text{ or } H_{t2} - H_{t1} = J_s \quad (13b)$$

where the subscripts 1 and 2 indicate the media under consideration and \bar{n}_{12} denotes the unit normal vector to the interface and is directed from Medium 1 into Medium 2. In the case where the materials are linear and isotropic, Equations (13a) and (13b) become

$$\bar{n}_{12} \cdot (\mu_2 \bar{H}_2 - \mu_1 \bar{H}_1) = 0 \quad (13c)$$

$$\bar{n}_{12} \times \left(\frac{\bar{B}_2}{\mu_2} - \frac{\bar{B}_1}{\mu_1} \right) = \bar{J}_s \quad (13d)$$

\bar{J}_s is a true surface current density that may exist at the interface. At an interface where \bar{J}_s is 0, Equations (13b) and (13d) need to be modified accordingly.

FERROMAGNETIC PROLATE SPHEROIDAL SHELL WITH INTERNAL AND EXTERNAL, INFINITESIMALLY THIN, PROLATE SPHEROIDAL CURRENT BANDS

GENERAL SOLUTION

We now proceed to solve the boundary value problem of a ferromagnetic prolate spheroidal shell of homogeneous permeability μ_2 with internal and external, infinitesimally thin, prolate spheroidal current bands of constant current density \bar{J}_1 and \bar{J}_2 , respectively. The geometry of the problem suggests that a prolate spheroidal coordinate system as shown in Figure 1 be used in the problem solution. Figure 2, a cross section of the problem geometry, identifies the five regions of interest. The boundaries of the prolate spheroidal shell are determined by $\eta = \eta_2$ and $\eta = \eta_3$, constants. The direct currents lie in the boundaries $\eta = \eta_1$ and $\eta = \eta_4$, constants. Regions I, II, IV, and V have a permeability equal to free space, μ_0 , which for convenience will be labelled μ_1 . Ampere's Law states

$$\bar{\nabla} \times \bar{H} = \bar{J} \quad (14)$$

and since $\nabla \cdot \bar{B} = 0$, the induction \bar{B} must be the curl of some vector field \bar{A} . The governing differential equation for \bar{A} when homogeneous and linear materials are considered, is from Equation (12)

$$\nabla^2 \bar{A} = -\mu \bar{J} \quad (15)$$

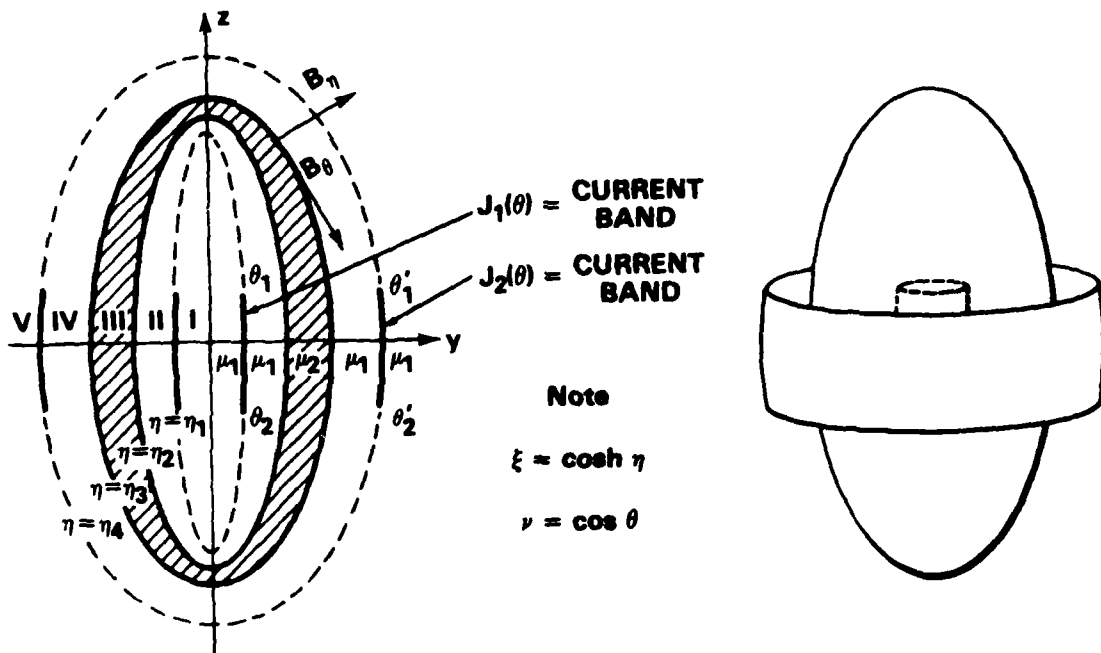

Figure 2 - Cross Section of Ferromagnetic Spheroidal Shell Surrounding and Surrounded by Infinitesimally Thin Current Bands

The general expression in prolate spheroidal coordinates for a current density is

$$\bar{J} = J_\eta \bar{e}_\eta + J_\theta \bar{e}_\theta + J_\psi \bar{e}_\psi \quad (16)$$

In the problem presented herein, the current densities have only a psi (ψ) component $[J_\psi(\theta) \bar{e}_\psi]$, which means that the vector potential has only a psi component $A_\psi \bar{e}_\psi$. The vector potential $[\bar{A} = A_\psi \bar{e}_\psi]$ is a function of the

prolate spheroidal coordinates η, θ [i.e., $A_\psi = A_\psi(\eta, \theta)$]. The constant current densities, which lie on the boundaries between Regions I and II and Regions IV and V, can be expressed by the functions

$$\bar{J}_1 = \begin{cases} 0, & \text{if } \theta < \theta_1 \text{ or } \theta > \theta_2 \\ J_{\psi 1}(\theta) \bar{e}_\psi, & \text{if } \theta_1 \leq \theta \leq \theta_2 \end{cases} \quad (17)$$

where $J_{\psi 1}(\theta)$ is equal to a constant J_1 along $\eta = \eta_1$ for $\theta_1 \leq \theta \leq \theta_2$ and

$$\bar{J}_2 = \begin{cases} 0, & \text{if } \theta < \theta'_1 \text{ or } \theta > \theta'_2 \\ J_{\psi 2}(\theta) \bar{e}_\psi, & \text{if } \theta'_1 \leq \theta \leq \theta'_2 \end{cases} \quad (18)$$

where $J_{\psi 2}(\theta)$ is equal to a constant J_2 along $\eta = \eta_4$ for $\theta'_1 \leq \theta \leq \theta'_2$. Therefore, Equation (15) has only an azimuthal or psi component and can be expressed as

$$\nabla^2 \bar{A} = \nabla^2 \bar{A}_\psi(\eta, \theta) = 0 \text{ in Regions I through V} \quad (19)$$

When the vector Laplacian $\nabla^2 \bar{A}_\psi$ is expanded in prolate spheroidal coordinates, Equation (19) can be expressed (see Appendix A, reference 2)

$$\frac{\partial}{\partial \eta} \left[\frac{1}{\sinh \eta} \frac{\partial (\sinh \eta A_\psi)}{\partial \eta} \right] + \frac{\partial}{\partial \theta} \left[\frac{1}{\sin \theta} \frac{\partial (\sin \theta A_\psi)}{\partial \theta} \right] = 0 \quad (20)$$

Applying the method of separation of variables, let us assume that \bar{A} can be expressed as the product of two functions

$$A_\psi = H(\cosh \eta) G(\cos \theta) \quad (21)$$

where H ($\cosh \eta$) is a function of $\cosh \eta$ only, and G ($\cos \theta$) is a function of $\cos \theta$ only.

Substituting this form of the vector potential \bar{A} into Equation (20), we have after separation of variables

$$\frac{d^2 H}{d\eta^2} + \coth \eta \frac{dH}{d\eta} - \left(p(p+1) + \frac{1}{\sinh^2 \eta} \right) H = 0 \quad (22a)$$

$$\frac{d^2 G}{d\theta^2} + \cot \theta \frac{dG}{d\theta} + \left(p(p+1) - \frac{1}{\sin^2 \theta} \right) G = 0 \quad (22b)$$

where the separation constant is $p(p+1)$ and p is an integer from one to infinity. It is well known that differential equations of the form

$$\frac{d^2 H'}{d\eta^2} + \coth \eta \frac{dH'}{d\eta} - \left(p(p+1) + \frac{m^2}{\sinh^2 \eta} \right) H' = 0 \quad (23a)$$

have the general solution of the form

$$H' = C_1 P_p^m (\cosh \eta) + C_2 Q_p^m (\cosh \eta) \quad (23b)$$

where C_1 and C_2 are constants and it is known that a differential equation of the form

$$\frac{d^2 G'}{d\theta^2} + \cot \theta \frac{dG'}{d\theta} + \left(p(p+1) - \frac{m^2}{\sin^2 \theta} \right) G' = 0 \quad (24a)$$

has the general solution of the type

$$G' = C_3 P_p^m (\cos \theta) + C_4 Q_p^m (\cos \theta) \quad (24b)$$

where C_3 and C_4 are constants. P_p^m and Q_p^m are the associated Legendre functions of the first and second kind, respectively.

Comparison of Equations (22), (23), and (24) shows that, in Equations (23) and (24), m^2 is equal to 1. This requires that m always equals unity. The solutions of Equations (22a) and (22b) are expressed as

$$H(\cosh \eta) = AP_p^1(\cosh \eta) + BQ_p^1(\cosh \eta) \quad (25a)$$

$$G(\cos \theta) = A'P_p^1(\cos \theta) + B'Q_p^1(\cos \theta) \quad (25b)$$

The general solution of Equation (20) may be formed from the product of solutions in Equations (25a) and (25b), which yield

$$A_\psi = H(\cosh \eta) G(\cos \theta) = \sum_{p=1}^{\infty} H_p(\cosh \eta) G_p(\cos \theta) \quad (26)$$

$$A_\psi = \sum_{p=1}^{\infty} \left[AP_p^1(\cosh \eta) + BQ_p^1(\cosh \eta) \right] \times \left[A'P_p^1(\cos \theta) + B'Q_p^1(\cos \theta) \right] \quad (27)$$

P_p^m and Q_p^m are the associated Legendre functions of the first and second kind, respectively.

For the prolate spheroidal system, the associated Legendre functions of the second kind are infinite at $\cos \theta = \pm 1$, and as such cannot be included in a general solution for a given region which includes $\theta = 0$ or $\theta = \pi$. Therefore, in our case, the constant B' is set equal to zero. Equation (27) reduces to

$$A_\psi = \sum_{p=1}^{\infty} \left[K_1 P_p^1(\cosh \eta) + K_2 Q_p^1(\cosh \eta) \right] P_p^1(\cos \theta) \quad (28)$$

where K_1 and K_2 are constants ($K_1 = AA'$, $K_2 = BA'$). When the substitutions $\xi = \cosh \eta$ and $\nu = \cos \theta$ are made in Equation (28), A_ψ can be expressed as

$$A_\psi = \sum_{p=1}^{\infty} \left[K_1 P_p^1(\xi) + K_2 Q_p^1(\xi) \right] P_p^1(\nu) \quad (29)$$

This is the general form of the psi component of the vector potential that will be used to determine the potentials A_ψ in each direction.

BOUNDARY CONDITIONS

The form of the component of the vector potential A_ψ in Regions I through V is determined from Equation (29). These magnetostatic vector potentials in Regions I through V are:

$$\begin{aligned} A_{\psi I} &= \sum_{p=1}^{\infty} \left[A_p P_p^1(\xi) \right] P_p^1(\nu) \\ A_{\psi II} &= \sum_{p=1}^{\infty} \left[B_p P_p^1(\xi) + C_p Q_p^1(\xi) \right] P_p^1(\nu) \\ A_{\psi III} &= \sum_{p=1}^{\infty} \left[D_p P_p^1(\xi) + E_p Q_p^1(\xi) \right] P_p^1(\nu) \\ A_{\psi IV} &= \sum_{p=1}^{\infty} \left[F_p P_p^1(\xi) + G_p Q_p^1(\xi) \right] P_p^1(\nu) \\ A_{\psi V} &= \sum_{p=1}^{\infty} \left[H_p Q_p^1(\xi) \right] P_p^1(\nu) \end{aligned} \quad (30)$$

Because the potential must be finite in each of the Regions I through IV, and approach zero as $\xi \rightarrow \infty$ in Region V, the following constants were set equal to zero:

a. For $A_{\psi I}$, the constant associated with $Q_p^1(\xi) P_p^1(\nu)$ was set equal to zero because

$$Q_p^1(\xi) \rightarrow \infty \text{ at } \xi = 1 \text{ (z axis between } \pm a)$$

b. For $A_{\psi V}$, the constant associated with $P_p^1(\xi) P_p^1(\nu)$ was set equal to zero because

$$P_p^1(\xi) \rightarrow \infty \text{ as } \xi \rightarrow \infty$$

(we note $Q_p^1(\xi) \rightarrow 0$ as $\xi \rightarrow \infty$).

$A_p, B_p, C_p, D_p, E_p, F_p, G_p,$ and H_p are constants to be determined from the boundary conditions. At each interface, the basic laws of magnetostatics (Equations (2a) and (2b)) reduce to boundary conditions on \bar{B} and \bar{H} that can be used to evaluate these eight constants. The normal component of \bar{B} across each boundary must be continuous; i.e., $(\bar{B}_2 - \bar{B}_1) \cdot \bar{n}_{12} = 0$ where the quantity \bar{n}_{12} is the unit outward normal to the surface. This provides the following boundary conditions which must be satisfied by the solutions given in Equation (30) for each region

$$B_{\eta I} = B_{\eta II} \quad \eta = \eta_1 \quad (31a)$$

$$B_{\eta II} = B_{\eta III} \quad \eta = \eta_2 \quad (31b)$$

$$B_{\eta III} = B_{\eta IV} \quad \eta = \eta_3 \quad (31c)$$

$$B_{\eta IV} = B_{\eta V} \quad \eta = \eta_4 \quad (31d)$$

The eta, or normal, component B_η of the magnetic field is expressed in terms of the vector potential as

$$B_\eta = (\bar{\nabla} \times A_\psi)_\eta = \frac{1}{e_2 e_3} \frac{\partial (e_3 A_\psi)}{\partial \theta} = - \frac{1}{a(\xi^2 - \nu^2)^{1/2}} \frac{\partial}{\partial \nu} \left[(1 - \nu^2)^{1/2} A_\psi \right] \quad (32)$$

where

$$\bar{B} = \bar{\nabla} \times \bar{A} = \frac{1}{a(\sinh^2 \eta + \sin^2 \theta)(\sinh \eta \sin \theta)} \times$$

$$\begin{vmatrix} \bar{e}_\eta (\sinh^2 \eta + \sin^2 \theta)^{\frac{1}{2}} & \bar{e}_\theta (\sinh^2 \eta + \sin^2 \theta)^{\frac{1}{2}} & \bar{e}_\psi (\sinh \eta \sin \theta) \\ \frac{\partial}{\partial \eta} & \frac{\partial}{\partial \theta} & \frac{\partial}{\partial \psi} \\ 0 & 0 & A_\psi \sinh \eta \sin \theta \end{vmatrix}$$

and

$$\xi = \cosh \eta, \quad e_1 = e_2 = a(\sinh^2 \eta + \sin^2 \theta)^{\frac{1}{2}} = a(\xi^2 - \nu^2)^{\frac{1}{2}}, \quad \nu = \cos \theta \\ e_3 = a(\sinh \eta \sin \theta)$$

However, since the vector potentials in each region are functions of $P_P^1(\nu)$, we can simplify Equation (32) to constraints on A_ψ at the interfaces:

$$A_{\psi I} = A_{\psi II} \quad \text{at} \quad \eta = \eta_1 \quad (33a)$$

$$A_{\psi II} = A_{\psi III} \quad \text{at} \quad \eta = \eta_2 \quad (33b)$$

$$A_{\psi III} = A_{\psi IV} \quad \text{at} \quad \eta = \eta_3 \quad (33c)$$

$$A_{\psi IV} = A_{\psi V} \quad \text{at} \quad \eta = \eta_4 \quad (33d)$$

The second set of boundary conditions states that the theta, or tangential, component of \bar{H} across each boundary must satisfy the relationship

$$\bar{n}_{12} \times (\bar{H}_2 - \bar{H}_1) = \bar{J}_s \quad (34)$$

where \bar{J}_s (which equals $J_\psi(\theta)$) is the real surface current density in the limit of vanishing width between the two regions. Using the relationship $\bar{B} = \mu \bar{H}$, Equation (34) can be expressed as

$$\frac{B_{\theta 2}}{\mu_2} - \frac{B_{\theta 1}}{\mu_1} = J_\psi(\theta) \quad (35)$$

The current must be expanded in a series of associated Legendre functions $P_p^1(v)$ as in Reference 2. The form of the current is

$$J_\psi(\theta) = \frac{J \sum_{p=1}^{\infty} v_p P_p^1(\cos \theta)}{a(\sinh^2 \eta + \sin^2 \theta)^{\frac{1}{2}}} \quad (36)$$

where using $\xi = \cosh \eta$, $v = \cos \theta$, v_p can be shown to be

$$v_p = \frac{-(2p+1)a}{2p(p+1)} \int_{v_1}^{v_2} (\xi^2 - v^2)^{\frac{1}{2}} P_p^1(v) dv \quad (37)$$

For the two current bands of interest, we have

$$J_{\psi 1}(\theta) = \frac{J_1 \sum_{p=1}^{\infty} v_p P_p^1(v)}{a(\xi_1^2 - v^2)^{\frac{1}{2}}} \quad (38a)$$

where

$$v_p = \frac{-(2p+1)a}{2p(p+1)} \int_{v_1}^{v_2} (\xi_1^2 - v^2)^{\frac{1}{2}} P_p^1(v) dv \quad (38b)$$

and

$$J_{\psi 2}(\theta) = \frac{J_2 \sum_{p=1}^{\infty} U_p P_p^1(v)}{a(\xi_4^2 - v^2)^{\frac{1}{2}}} \quad (39a)$$

where

$$U_p = \frac{-(2p+1)a}{2p(p+1)} \int_{v_1'}^{v_2'} (\xi_4^2 - v^2)^{\frac{1}{2}} P_p^1(v) dv \quad (39b)$$

and $v_1' = \cos \theta_1'$ and $v_2' = \cos \theta_2'$.

Referring to the curl in Equation (32), we can write B_θ in the form

$$B_\theta = (\bar{\nabla} \times \bar{A}_\psi)_\theta = -\frac{1}{e_1 e_3} \frac{\partial (e_3 A_\psi)}{\partial \eta} = -\frac{1}{a(\xi^2 - v^2)^{\frac{1}{2}}} \frac{\partial}{\partial \xi} [(\xi^2 - 1)^{\frac{1}{2}} A_\psi] \quad (40)$$

From Equations (35 and (40), the tangential components of \bar{B} in Region: I through V must satisfy the relationships

$$\begin{aligned} & + \left(\frac{1}{\mu_1} \right) \frac{1}{a(\xi_1^2 - v^2)^{\frac{1}{2}}} \frac{\partial}{\partial \xi} [(\xi^2 - 1)^{\frac{1}{2}} A_{\psi I}] \Bigg|_{\xi=\xi_1} \\ & - \left(\frac{1}{\mu_1} \right) \frac{1}{a(\xi_1^2 - v^2)^{\frac{1}{2}}} \frac{\partial}{\partial \xi} [(\xi^2 - 1)^{\frac{1}{2}} A_{\psi II}] \Bigg|_{\xi=\xi_1} \\ & = J_{p1}(\theta) = \frac{J_1 \sum_{p=1}^{\infty} v_p P_p^1(v)}{a(\xi_1^2 - v^2)^{\frac{1}{2}}} \quad (41a) \end{aligned}$$

$$\begin{aligned}
& \left(\frac{1}{\mu_2} \right) \frac{1}{a(\xi_2^2 - v^2)^{\frac{1}{2}}} \frac{\partial}{\partial \xi} \left[(\xi^2 - 1)^{\frac{1}{2}} A_{\psi \text{III}} \right] \Big|_{\xi = \xi_2} \\
& = \left(\frac{1}{\mu_1} \right) \frac{1}{a(\xi_2^2 - v^2)^{\frac{1}{2}}} \frac{\partial}{\partial \xi} \left[(\xi^2 - 1)^{\frac{1}{2}} A_{\psi \text{II}} \right] \Big|_{\xi = \xi_2} \quad (41b)
\end{aligned}$$

$$\begin{aligned}
& \left(\frac{1}{\mu_1} \right) \frac{1}{a(\xi_3^2 - v^2)^{\frac{1}{2}}} \frac{\partial}{\partial \xi} \left[(\xi^2 - 1)^{\frac{1}{2}} A_{\psi \text{IV}} \right] \Big|_{\xi = \xi_3} \\
& = \left(\frac{1}{\mu_2} \right) \frac{1}{a(\xi_3^2 - v^2)^{\frac{1}{2}}} \frac{\partial}{\partial \xi} \left[(\xi^2 - 1)^{\frac{1}{2}} A_{\psi \text{III}} \right] \Big|_{\xi = \xi_3} \quad (41c)
\end{aligned}$$

$$\begin{aligned}
& + \left(\frac{1}{\mu_1} \right) \frac{1}{a(\xi_4^2 - v^2)^{\frac{1}{2}}} \frac{\partial}{\partial \xi} \left[(\xi^2 - 1)^{\frac{1}{2}} A_{\psi \text{IV}} \right] \Big|_{\xi = \xi_4} \\
& - \left(\frac{1}{\mu_1} \right) \frac{1}{a(\xi_4^2 - v^2)^{\frac{1}{2}}} \frac{\partial}{\partial \xi} \left[(\xi^2 - 1)^{\frac{1}{2}} A_{\psi \text{V}} \right] \Big|_{\xi = \xi_4} \\
& = J_{p2}(\theta) = \frac{J_2 \sum_{p=1}^{\infty} U_p P_p^1(v)}{a(\xi_4^2 - v^2)^{\frac{1}{2}}} \quad (41d)
\end{aligned}$$

The general expressions for the potentials in each region (Equation (30)) are then substituted into the boundary conditions (Equations (33) and (41)) and solved for the eight constants ($A_p, B_p, C_p, D_p, E_p, F_p, G_p,$ and H_p). Since there are eight equations with eight unknowns, the potential in each region can be specified. The eight boundary value equations are presented below. The index, p , in the summation sign has both even and odd value and it takes on values from 1 to ∞ . The eight expressions for the boundary conditions are:

$$A_p P_p^1(\xi_1) P_p^1(\nu) = [B_p P_p^1(\xi_1) + C_p Q_p^1(\xi_1)] P_p^1(\nu) \quad (42a)$$

$$-\left(\frac{1}{\mu_1}\right) \frac{1}{a(\xi_1^2 - \nu^2)^{\frac{1}{2}}} \frac{\partial}{\partial \xi} \left[(\xi^2 - 1)^{\frac{1}{2}} (B_p P_p^1(\xi) + C_p Q_p^1(\xi)) P_p^1(\nu) \right] \Bigg|_{\xi=\xi_1}$$

$$+\left(\frac{1}{\mu_1}\right) \frac{1}{a(\xi_1^2 - \nu^2)^{\frac{1}{2}}} \frac{\partial}{\partial \xi} \left[(\xi^2 - 1)^{\frac{1}{2}} (A_p P_p^1(\xi)) P_p^1(\nu) \right] \Bigg|_{\xi=\xi_1} = J_{p1}(\theta) \quad (42b)$$

$$[B_p P_p^1(\xi_2) + C_p Q_p^1(\xi_2)] P_p^1(\nu) = [D_p P_p^1(\xi_2) + E_p Q_p^1(\xi_2)] P_p^1(\nu) \quad (42c)$$

$$\begin{aligned}
& \left(\frac{1}{\mu_2} \right) \frac{1}{a(\xi_2^2 - v^2)^{\frac{1}{2}}} \frac{\partial}{\partial \xi} \left[(\xi^2 - 1)^{\frac{1}{2}} \left(D_P P_P^1(\xi) + E_P Q_P^1(\xi) \right) P_P^1(v) \right] \Bigg|_{\xi=\xi_2} \\
& = \left(\frac{1}{\mu_1} \right) \frac{1}{a(\xi_2^2 - v^2)^{\frac{1}{2}}} \frac{\partial}{\partial \xi} \left[(\xi^2 - 1)^{\frac{1}{2}} \left(B_P P_P^1(\xi) + C_P Q_P^1(\xi) \right) P_P^1(v) \right] \Bigg|_{\xi=\xi_2} \quad (42d)
\end{aligned}$$

$$\left[D_P P_P^1(\xi_3) + E_P Q_P^1(\xi_3) \right] P_P^1(v) = \left[F_P P_P^1(\xi_3) + G_P Q_P^1(\xi_3) \right] P_P^1(v) \quad (42e)$$

$$\left(\frac{1}{\mu_1} \right) \frac{1}{a(\xi_3^2 - v^2)^{\frac{1}{2}}} \frac{\partial}{\partial \xi} \left[(\xi^2 - 1)^{\frac{1}{2}} \left(F_P P_P^1(\xi) + G_P Q_P^1(\xi) \right) P_P^1(v) \right] \Bigg|_{\xi=\xi_3} =$$

$$\left(\frac{1}{\mu_2} \right) \frac{1}{a(\xi_3^2 - v^2)^{\frac{1}{2}}} \frac{\partial}{\partial \xi} \left[(\xi^2 - 1)^{\frac{1}{2}} \left(D_P P_P^1(\xi) + E_P Q_P^1(\xi) \right) P_P^1(v) \right] \Bigg|_{\xi=\xi_3} \quad (42f)$$

$$\left[F_P P_P^1(\xi_4) + G_P Q_P^1(\xi_4) \right] P_P^1(v) = H_P Q_P^1(\xi_4) P_P^1(v) \quad (42g)$$

$$\begin{aligned}
& \left(-\frac{1}{\mu_1} \right) \frac{1}{a(\xi_4^2 - \nu^2)^{\frac{1}{2}}} \frac{\partial}{\partial \xi} \left[(\xi^2 - 1)^{\frac{1}{2}} \left(H_P Q_P^1(\xi) \right) P_P^1(\nu) \right] \Bigg|_{\xi=\xi_4} \\
& + \left(\frac{1}{\mu_1} \right) \frac{1}{a(\xi_4^2 - \nu^2)^{\frac{1}{2}}} \frac{\partial}{\partial \xi} \left[(\xi^2 - 1)^{\frac{1}{2}} \left(F_P P_P^1(\xi) + G_P Q_P^1(\xi) \right) P_P^1(\nu) \right] \Bigg|_{\xi=\xi_4} = J_{p2}(\theta)
\end{aligned} \tag{42h}$$

By making the following substitutions

$$P_P^\Delta(\xi) = \frac{\partial}{\partial \xi} \left[(\xi^2 - 1)^{\frac{1}{2}} P_P^1(\xi) \right]$$

$$Q_P^\Delta(\xi) = \frac{\partial}{\partial \xi} \left[(\xi^2 - 1)^{\frac{1}{2}} Q_P^1(\xi) \right]$$

and performing algebraic manipulation, the eight boundary conditions can be simplified to:

$$A_P P_P^1(\xi_1) = B_P P_P^1(\xi_1) + C_P Q_P^1(\xi_1) \tag{43a}$$

$$-\left(\frac{1}{\mu_1} \right) \left[B_P P_P^\Delta(\xi_1) + C_P Q_P^\Delta(\xi_1) \right] + \left(\frac{1}{\mu_1} \right) \left[A_P P_P^\Delta(\xi_1) \right]$$

$$= \frac{J_{p1}(\theta) a(\xi_1^2 - \nu^2)^{\frac{1}{2}}}{P_P^1(\nu)} \tag{43b}$$

$$B_p P_p^1(\xi_2) + C_p Q_p^1(\xi_2) = D_p P_p^1(\xi_2) + E_p Q_p^1(\xi_2) \quad (43c)$$

$$\left(\frac{1}{\mu_2}\right) [D_p P_p^\Delta(\xi_2) + E_p Q_p^\Delta(\xi_2)] = \left(\frac{1}{\mu_1}\right) [B_p P_p^\Delta(\xi_2) + C_p Q_p^\Delta(\xi_2)] \quad (43d)$$

$$D_p P_p^1(\xi_3) + E_p Q_p^1(\xi_3) = F_p P_p^1(\xi_3) + G_p Q_p^1(\xi_3) \quad (43e)$$

$$\left(\frac{1}{\mu_2}\right) [D_p P_p^\Delta(\xi_3) + E_p Q_p^\Delta(\xi_3)] = \left(\frac{1}{\mu_1}\right) [F_p P_p^\Delta(\xi_3) + G_p Q_p^\Delta(\xi_3)] \quad (43f)$$

$$[F_p P_p^1(\xi_4) + G_p Q_p^1(\xi_4)] = H_p Q_p^1(\xi_4) \quad (43g)$$

$$\left(-\frac{1}{\mu_1}\right) (H_p Q_p^\Delta(\xi_4)) + \left(\frac{1}{\mu_1}\right) (F_p P_p^\Delta(\xi_4) + G_p Q_p^\Delta(\xi_4))$$

$$= \frac{J_{p2}(\theta) a(\xi_4^2 - v^2)^{\frac{1}{2}}}{P_p^1(v)} \quad (43h)$$

The solution of these eight simultaneous equations to obtain the constants gives:

$$A_p = B_p + C_p \frac{Q_p^1(\xi_1)}{P_p^1(\xi_1)} \quad (44a)$$

$$C_p = \frac{\left[\frac{\mu_1 J_{p1}(\theta) a(\xi_1^2 - v^2)^{1/2}}{P_p^1(v) P_p^\Delta(\xi_1)} \right]}{\left[\frac{Q_p^1(\xi_1)}{P_p^1(\xi_1)} - \frac{Q_p^\Delta(\xi_1)}{P_p^\Delta(\xi_1)} \right]} = J_{p1}^I \quad (44b)$$

$$F_p = E_p \frac{Q_p^1(\xi_3)}{P_p^1(\xi_3)} - G_p \frac{Q_p^\Delta(\xi_3)}{P_p^\Delta(\xi_3)} + D_p \quad (44c)$$

$$E_p = D_p [Q] - G_p [R] \quad (44d)$$

where

$$[Q] = \left(\frac{\mu_1}{\mu_2} - 1 \right) \left/ \left[\frac{Q_p^1(\xi_3)}{P_p^1(\xi_3)} - \left(\frac{\mu_1}{\mu_2} \right) \frac{Q_p^\Delta(\xi_3)}{P_p^\Delta(\xi_3)} \right] \right.$$

$$[R] = \left[\frac{Q_p^\Delta(\xi_3)}{P_p^\Delta(\xi_3)} - \frac{Q_p^1(\xi_3)}{P_p^1(\xi_3)} \right] \left/ \left[\frac{Q_p^1(\xi_3)}{P_p^1(\xi_3)} - \left(\frac{\mu_1}{\mu_2} \right) \frac{Q_p^\Delta(\xi_3)}{P_p^\Delta(\xi_3)} \right] \right.$$

$$B_p = J_{p1}^{II} + D_p [S] - G_p [Z] \quad (44e)$$

where

$$J_{p1}^{II} = -J_{p1}^I \frac{Q_p^1(\xi_2)}{P_p^1(\xi_2)}, \quad J_{p1}^I = \left[\frac{\mu_1 J_{p1}(0) a(\xi_1^2 - v^2)^{\frac{1}{2}}}{P_p^1(v) P_p^\Delta(\xi_1)} \right] / \left[\frac{Q_p^1(\xi_1)}{P_p^1(\xi_1)} - \frac{Q_p^\Delta(\xi_3)}{P_p^\Delta(\xi_1)} \right]$$

$$[S] = \left(1 + [Q] \frac{Q_p^1(\xi_2)}{P_p^1(\xi_2)} \right)$$

$$[Z] = \left([R] \frac{Q_p^1(\xi_2)}{P_p^1(\xi_2)} \right).$$

$$D_p = J_{p1}^{III} + [U] G_p \quad (44f)$$

where

$$J_{p1}^{III} = \frac{\left(\frac{1}{\mu_1} \right) J_{p1}^I Q_p^\Delta(\xi_2) + \left(\frac{1}{\mu_1} \right) J_{p1}^{II} P_p^\Delta(\xi_2)}{\left[\left(-\frac{1}{\mu_1} \right) [S] P_p^\Delta(\xi_2) + \left(\frac{1}{\mu_2} \right) P_p^\Delta(\xi_2) + \left(\frac{1}{\mu_2} \right) [Q] Q_p^\Delta(\xi_2) \right]}$$

$$[U] = \frac{\left(-\frac{1}{\mu_1} \right) [Z] P_p^\Delta(\xi_2) + \left(\frac{1}{\mu_2} \right) [R] Q_p^\Delta(\xi_2)}{\left[\left(-\frac{1}{\mu_1} \right) [S] P_p^\Delta(\xi_2) + \left(\frac{1}{\mu_2} \right) P_p^\Delta(\xi_2) + \left(\frac{1}{\mu_2} \right) [Q] Q_p^\Delta(\xi_2) \right]}$$

$$H_p = G_p + J_{p2}^{II} \quad (44g)$$

where

$$J_{p2}^{II} = J_{p2}^I / [A] - [C]$$

$$[A] = Q_p^1(\xi_4) / P_p^1(\xi_4)$$

$$[C] = \frac{Q_p^\Delta(\xi_4)}{P_p^\Delta(\xi_4)} .$$

$$G_p = \frac{-J_{p1}^{III} [Q] [H] - J_{p1}^{III} + J_{p2}^{II} [A]}{[U] [Q] [H] - [R] [H] - [H] + [U]} \quad (44h)$$

where

$$J_{p1}^{III} = \frac{\left(\frac{1}{\mu_1}\right) J_p^I Q_p^\Delta(\xi_2) + \left(\frac{1}{\mu_1}\right) J_{p1}^{II} P_p^\Delta(\xi_2)}{\left[\left(-\frac{1}{\mu_1}\right) [S] P_p^\Delta(\xi_2) + \left(\frac{1}{\mu_2}\right) P_p^\Delta(\xi_2) + \left(\frac{1}{\mu_2}\right) [Q] Q_p^\Delta(\xi_2) \right]}$$

$$J_{p2}^I = \frac{\mu_1 J_{p2}(\theta) a(\xi_4^2 - v^2)^{\frac{1}{2}}}{P_p^\Delta(\xi_4) P_p^1(v)}$$

$$[H] = Q_p^1(\xi_3) / P_p^1(\xi_3) .$$

Since the eight coefficients can be determined for a specified problem from Equation (44), the potentials A_I , A_{II} , A_{III} , A_{IV} , and A_V in Regions I through V can be completely determined. The normal (B_η) and tangential (B_θ) components of the magnetic induction in each region, I through V, can be determined by using Equations (32) and (40).

APPENDIX A

DERIVATION OF COEFFICIENTS OF THE VECTOR POTENTIAL FOR A FERROMAGNETIC PROLATE SPHEROIDAL SHELL WITH INTERNAL AND EXTERNAL, INFINITESIMALLY THIN, PROLATE SPHEROIDAL CURRENT BANDS

In this appendix, the coefficients are derived for the vector potential in Regions I through V for a ferromagnetic spheroidal shell with internal and external, infinitely thin, spheroidal current bands. For a detailed discussion of the ferromagnetic problem, see the body of this report. The components of the magnetic vector potential in each region is given by

$$A_{\psi I} = \sum_{p=1}^{\infty} \left[A_p P_p^1(\xi) \right] P_p^1(\nu) \quad (\text{A.1a})$$

$$A_{\psi II} = \sum_{p=1}^{\infty} \left[B_p P_p^1(\xi) + C_p Q_p^1(\xi) \right] P_p^1(\nu) \quad (\text{A.1b})$$

$$A_{\psi III} = \sum_{p=1}^{\infty} \left[D_p P_p^1(\xi) + E_p Q_p^1(\xi) \right] P_p^1(\nu) \quad (\text{A.1c})$$

$$A_{\psi IV} = \sum_{p=1}^{\infty} \left[F_p P_p^1(\xi) + G_p Q_p^1(\xi) \right] P_p^1(\nu) \quad (\text{A.1d})$$

$$A_{\psi V} = \sum_{p=1}^{\infty} \left[H_p Q_p^1(\xi) \right] P_p^1(\nu) \quad (\text{A.1e})$$

The coefficients in Equations (A.1a) to (A.1e) are obtained by substituting these equations into Equations (33) and (41).

$$A_P P_P^1(\xi_1) P_P^1(\nu) = \left[B_P P_P^1(\xi_1) + C_P Q_P^1(\xi_1) \right] P_P^1(\nu) \quad (\text{A.2a})$$

$$- \left(\frac{1}{\mu_1} \right) \frac{1}{a(\xi_1^2 - \nu^2)^{\frac{1}{2}}} \frac{\partial}{\partial \xi} \left[(\xi^2 - 1)^{\frac{1}{2}} \left(B_P P_P^1(\xi) + C_P Q_P^1(\xi) \right) P_P^1(\nu) \right] \Big|_{\xi=\xi_1}$$

$$+ \left(\frac{1}{\mu_1} \right) \frac{1}{a(\xi_1^2 - \nu^2)^{\frac{1}{2}}} \frac{\partial}{\partial \xi} \left[(\xi^2 - 1)^{\frac{1}{2}} \left(A_P P_P^1(\xi) \right) P_P^1(\nu) \right] \Big|_{\xi=\xi_1} = J_{P1}(\theta) \quad (\text{A.2b})$$

$$\left[B_P P_P^1(\xi_2) + C_P Q_P^1(\xi_2) \right] P_P^1(\nu) = \left[D_P P_P^1(\xi_2) + E_P Q_P^1(\xi_2) \right] P_P^1(\nu) \quad (\text{A.2c})$$

$$\left(\frac{1}{\mu_2} \right) \frac{1}{a(\xi_2^2 - \nu^2)^{\frac{1}{2}}} \frac{\partial}{\partial \xi} \left[(\xi^2 - 1)^{\frac{1}{2}} \left(D_P P_P^1(\xi) + E_P Q_P^1(\xi) \right) P_P^1(\nu) \right] \Big|_{\xi=\xi_2}$$

$$= \left(\frac{1}{\mu_1} \right) \frac{1}{a(\xi_2^2 - \nu^2)^{\frac{1}{2}}} \frac{\partial}{\partial \xi} \left[(\xi^2 - 1)^{\frac{1}{2}} \left(B_P P_P^1(\xi) + C_P Q_P^1(\xi) \right) P_P^1(\nu) \right] \Big|_{\xi=\xi_2} \quad (\text{A.2d})$$

$$\left[D_p P_p^1(\xi_3) + E_p Q_p^1(\xi_3) \right] P_p^1(\nu) = \left[F_p P_p^1(\xi_3) + G_p Q_p^1(\xi_3) \right] P_p^1(\nu) \quad (\text{A.2e})$$

$$\begin{aligned} & \left(\frac{1}{\mu_1} \right) \frac{1}{a(\xi_3^2 - \nu^2)^{\frac{1}{2}}} \frac{\partial}{\partial \xi} \left[(\xi^2 - 1)^{\frac{1}{2}} \left(F_p P_p^1(\xi) + G_p Q_p^1(\xi) \right) P_p^1(\nu) \right] \Big|_{\xi=\xi_3} \\ &= \left(\frac{1}{\mu_2} \right) \frac{1}{a(\xi_3^2 - \nu^2)^{\frac{1}{2}}} \frac{\partial}{\partial \xi} \left[(\xi^2 - 1)^{\frac{1}{2}} \left(D_p P_p^1(\xi) + E_p Q_p^1(\xi) \right) P_p^1(\nu) \right] \Big|_{\xi=\xi_3} \end{aligned} \quad (\text{A.2f})$$

$$\left[F_p P_p^1(\xi_4) + G_p Q_p^1(\xi_4) \right] P_p^1(\nu) = H_p Q_p^1(\xi_4) P_p^1(\nu) \quad (\text{A.2g})$$

$$\begin{aligned} & \left(-\frac{1}{\mu_1} \right) \frac{1}{a(\xi_4^2 - \nu^2)^{\frac{1}{2}}} \frac{\partial}{\partial \xi} \left[(\xi^2 - 1)^{\frac{1}{2}} \left(H_p Q_p^1(\xi) \right) P_p^1(\nu) \right] \Big|_{\xi=\xi_4} \\ &+ \left(\frac{1}{\mu_1} \right) \frac{1}{a(\xi_4^2 - \nu^2)^{\frac{1}{2}}} \frac{\partial}{\partial \xi} \left[(\xi^2 - 1)^{\frac{1}{2}} \left(F_p P_p^1(\xi) + G_p Q_p^1(\xi) \right) P_p^1(\nu) \right] \Big|_{\xi=\xi_4} \\ &= J_{p2}(\theta) \end{aligned} \quad (\text{A.2h})$$

Define

$$P_p^\Delta(\xi) = \frac{\partial}{\partial \xi} [(\xi^2 - 1)^{\frac{1}{2}} P_p^1(\xi)] \quad (\text{A.3a})$$

$$Q_p^\Delta(\xi) = \frac{\partial}{\partial \xi} [(\xi^2 - 1)^{\frac{1}{2}} Q_p^1(\xi)] \quad (\text{A.3b})$$

After appropriate substitution of Equations (A.1a) to (A.1e) into Equations (33) and (41) and using Equations (A.3a) and (A.3b), the following boundary value equations are obtained.

$$A_p P_p^1(\xi_1) = B_p P_p^1(\xi_1) + C_p Q_p^1(\xi_1) \quad (\text{A.4a})$$

$$\left(-\frac{1}{\mu_1}\right) \left(B_p P_p^\Delta(\xi_1) + C_p Q_p^\Delta(\xi_1)\right) + \left(\frac{1}{\mu_1}\right) \left(A_p P_p^\Delta(\xi_1)\right) = \frac{J_{p1}(\theta) a(\xi_1^2 - v^2)^{\frac{1}{2}}}{P_p^1(v)} \quad (\text{A.4b})$$

$$B_p P_p^1(\xi_2) + C_p Q_p^1(\xi_2) = D_p P_p^1(\xi_2) + E_p Q_p^1(\xi_2) \quad (\text{A.4c})$$

$$\left(\frac{1}{\mu_2}\right) [D_p P_p^\Delta(\xi_2) + E_p Q_p^\Delta(\xi_2)] = \left(\frac{1}{\mu_1}\right) [B_p P_p^\Delta(\xi_2) + C_p Q_p^\Delta(\xi_2)] \quad (\text{A.4d})$$

$$D_p P_p^1(\xi_3) + E_p Q_p^1(\xi_3) = F_p P_p^1(\xi_3) + G_p Q_p^1(\xi_3) \quad (\text{A.4e})$$

$$\left(\frac{1}{\mu_2} \right) [D_p P_p^\Delta(\xi_3) + E_p Q_p^\Delta(\xi_3)] = \left(\frac{1}{\mu_1} \right) [F_p P_p^\Delta(\xi_3) + G_p Q_p^\Delta(\xi_3)] \quad (\text{A.4f})$$

$$F_p P_p^1(\xi_4) + G_p Q_p^1(\xi_4) = H_p Q_p^1(\xi_4) \quad (\text{A.4g})$$

$$\left(-\frac{1}{\mu_1} \right) [H_p Q_p^\Delta(\xi_4)] + \left(\frac{1}{\mu_1} \right) [F_p P_p^\Delta(\xi_4) + G_p Q_p^\Delta(\xi_4)] = \frac{J_{p2}(\theta) a(\xi_4^2 - v^2)^{\frac{1}{2}}}{P_p^1(v)} \quad (\text{A.4h})$$

These algebraic equations provide eight simultaneous equations with eight unknowns; and they can be solved for the coefficients A_p , B_p , C_p , D_p , E_p , F_p , G_p , and H_p . Solving Equation (A.4a) for A_p gives

$$A_p = B_p + C_p \frac{Q_p^1(\xi_1)}{P_p^1(\xi_1)} \quad (\text{A.5})$$

The solution of A_p from Equation (A.4b) is

$$A_p = B_p + C_p \frac{Q_p^\Delta(\xi_1)}{P_p^\Delta(\xi_1)} + \frac{\mu_1 J_{p1}(\theta) a(\xi_1^2 - v^2)^{\frac{1}{2}}}{P_p^1(v) P_p^\Delta(\xi_1)} \quad (\text{A.6})$$

Equating Equations (A.5) and (A.6) and solving for C_p gives

$$C_p = \left[\frac{\mu_1 J_{p1}(\theta) a(\xi_1^2 - v^2)^{1/2}}{P_p^1(v) P_p^\Delta(\xi_1)} \right] / \left[\frac{Q_p^1(\xi_1)}{P_p^1(\xi_1)} - \frac{Q_p^\Delta(\xi_1)}{P_p^\Delta(\xi_1)} \right] \quad (A.7)$$

$$C_p = J_{p1}^I \quad (A.8)$$

Solving Equation (A.4e) and (A.4f) for F_p gives

$$F_p = E_p \frac{Q_p^1(\xi_3)}{P_p^1(\xi_3)} - G_p \frac{Q_p^1(\xi_3)}{P_p^1(\xi_3)} + D_p \quad (A.9)$$

$$F_p = \left(\frac{\mu_1}{\mu_2} \right) \frac{[D_p P_p^\Delta(\xi_3) + E_p Q_p^\Delta(\xi_3)]}{P_p^\Delta(\xi_3)} - G_p \frac{Q_p^\Delta(\xi_3)}{P_p^\Delta(\xi_3)} \quad (A.10)$$

Equating Equations (A.9) and (A.10) and solving for E_p gives

$$E_p = D_p [Q] - G_p [R] \quad (A.11)$$

where

$$[Q] = \left(\frac{\mu_1}{\mu_2} - 1 \right) / \left[\frac{Q_p^1(\xi_3)}{P_p^1(\xi_3)} - \left(\frac{\mu_1}{\mu_2} \right) \frac{Q_p^\Delta(\xi_3)}{P_p^\Delta(\xi_3)} \right] \quad (A.12)$$

$$[R] = \left[\frac{Q_p^\Delta(\xi_3)}{P_p^\Delta(\xi_3)} - \frac{Q_p^1(\xi_3)}{P_p^1(\xi_3)} \right] / \left[\frac{Q_p^1(\xi_3)}{P_p^1(\xi_3)} - \left(\frac{\mu_1}{\mu_2} \right) \frac{Q_p^\Delta(\xi_3)}{P_p^\Delta(\xi_3)} \right] \quad (\text{A.13})$$

$$E_p = \frac{D_p \left[\frac{\mu_1}{\mu_2} - 1 \right] - G_p \frac{Q_p^\Delta(\xi_3)}{P_p^\Delta(\xi_3)} + G_p \frac{Q_p^1(\xi_3)}{P_p^1(\xi_3)}}{\left[\frac{Q_p^1(\xi_3)}{P_p^1(\xi_3)} - \left(\frac{\mu_1}{\mu_2} \right) \frac{Q_p^\Delta(\xi_3)}{P_p^\Delta(\xi_3)} \right]} \quad (\text{A.14})$$

Solving Equation (A.4c) for B_p and substituting Equations (A.8) and (A.11), gives

$$B_p = J_{p1}^{II} + D_p [S] - G_p [Z] \quad (\text{A.15})$$

where

$$J_{p1}^{II} = - J_{p1}^I \frac{Q_p^1(\xi_2)}{P_p^1(\xi_2)} \quad (\text{A.16})$$

$$[S] = \left[1 + [Q] \frac{Q_p^1(\xi_2)}{P_p^1(\xi_2)} \right] \quad (\text{A.17})$$

$$[Z] = [R] \frac{Q_p^1(\xi_2)}{P_p^1(\xi_2)} \quad (\text{A.18})$$

The solution of Equation (A.4d) for D_p and using Equations (A.8), (A.11), and (A.15) gives

$$D_p = \frac{\left(\frac{1}{\mu_1}\right) J_{p1}^I Q_p^\Delta(\xi_2) + \left(\frac{1}{\mu_1}\right) J_{p1}^{II} P_p^\Delta(\xi_2)}{\left[\left(-\frac{1}{\mu_1}\right) [S] P_p^\Delta(\xi_2) + \left(\frac{1}{\mu_2}\right) P_p^\Delta(\xi_2) + \left(\frac{1}{\mu_2}\right) [Q] Q_p^\Delta(\xi_2) \right]} + G_p \frac{-\left(\frac{1}{\mu_1}\right) [Z] P_p^\Delta(\xi_2) + \left(\frac{1}{\mu_2}\right) [R] Q_p^\Delta(\xi_2)}{\left[\left(-\frac{1}{\mu_1}\right) [S] P_p^\Delta(\xi_2) + \left(\frac{1}{\mu_2}\right) P_p^\Delta(\xi_2) + \left(\frac{1}{\mu_2}\right) [Q] Q_p^\Delta(\xi_2) \right]} \quad (A.19)$$

$$D_p = J_{p1}^{III} + [U] G_p \quad (A.20)$$

where

$$J_{p1}^{III} = \frac{\left(\frac{1}{\mu_1}\right) J_{p1}^I Q_p^\Delta(\xi_2) + \left(\frac{1}{\mu_1}\right) J_{p1}^{II} P_p^\Delta(\xi_2)}{\left[\left(-\frac{1}{\mu_1}\right) [S] P_p^\Delta(\xi_2) + \left(\frac{1}{\mu_2}\right) P_p^\Delta(\xi_2) + \left(\frac{1}{\mu_2}\right) [Q] Q_p^\Delta(\xi_2) \right]} \quad (A.21)$$

$$[U] = \frac{\left(-\frac{1}{\mu_1}\right) [Z] P_p^\Delta(\xi_2) + \left(\frac{1}{\mu_2}\right) [R] Q_p^\Delta(\xi_2)}{\left[\left(-\frac{1}{\mu_1}\right) [S] P_p^\Delta(\xi_2) + \left(\frac{1}{\mu_2}\right) P_p^\Delta(\xi_2) + \left(\frac{1}{\mu_2}\right) [Q] Q_p^\Delta(\xi_2) \right]} \quad (A.22)$$

Now, solving Equation (A.4g) for F_p gives

$$F_p = H_p [A] - G_p [A] \quad (\text{A.23})$$

where

$$[A] = \frac{Q_p^1(\xi_4)}{P_p^1(\xi_4)} \quad (\text{A.24})$$

The solution of Equation (A.4h) for F_p gives

$$F_p = -G_p [C] + H_p [C] + J_{p2}^I \quad (\text{A.25})$$

where

$$[C] = \frac{Q_p^\Delta(\xi_4)}{P_p^\Delta(\xi_4)} \quad (\text{A.26})$$

$$J_{p2}^I = \frac{\mu_1 J_{p2}(\theta) a(\xi_4^2 - v^2)^{\frac{1}{2}}}{P_p^\Delta(\xi_4) P_p^1(v)} \quad (\text{A.27})$$

Equating Equations (A.23) and (A.25) and solving for H_p , gives

$$H_p = G_p + J_{p2}^{II} \quad (\text{A.28})$$

where

$$J_{p2}^{II} = \frac{J_{p2}^I}{[A] - [C]} \quad (\text{A.29})$$

Now, solving Equation (A.4e) for F_p using

$$[H] = \frac{Q_p^1(\xi_3)}{P_p^1(\xi_3)} \quad (\text{A.30})$$

gives

$$F_p = E_p [H] - G_p [H] + D_p \quad (\text{A.31})$$

Now, solving Equations (A.23) and (A.31) for G_p using Equations (A.11), (A.20), and (A.28) gives

$$G_p = \frac{-J_{p1}^{III} [Q] [H] - J_{p1}^{III} + J_{p2}^{II} [A]}{[U] [Q] [H] - [R] [H] - [H] + [U]} \quad (\text{A.32})$$

where

$$[Q] = \left(\frac{\mu_1}{\mu_2} - 1 \right) / \left[\frac{Q_p^1(\xi_3)}{P_p^1(\xi_3)} - \left(\frac{\mu_1}{\mu_2} \right) \frac{Q_p^\Delta(\xi_3)}{P_p^\Delta(\xi_3)} \right] \quad (\text{A.33})$$

$$[R] = \left[\frac{Q_p^\Delta(\xi_3)}{P_p^\Delta(\xi_3)} - \frac{Q_p^1(\xi_3)}{P_p^1(\xi_3)} \right] / \left[\frac{Q_p^1(\xi_3)}{P_p^1(\xi_3)} - \left(\frac{\mu_1}{\mu_2} \right) \frac{Q_p^\Delta(\xi_3)}{P_p^\Delta(\xi_3)} \right] \quad (\text{A.34})$$

$$[S] = \left[1 + [Q] \left(\frac{Q_p^1(\xi_2)}{P_p^1(\xi_2)} \right) \right] \quad (\text{A.35})$$

$$[Z] = \left[[R] \frac{Q_p^1(\xi_2)}{P_p^1(\xi_2)} \right] \quad (\text{A.36})$$

$$J_{p1}^I = \left[\frac{\mu_1 J_{p1}(\theta) a(\xi_1^2 - v^2)^{\frac{1}{2}}}{P_p^1(v) P_p^\Delta(\xi_1)} \right] / \left[\frac{Q_p^1(\xi_1)}{P_p^1(\xi_1)} - \frac{Q_p^\Delta(\xi_3)}{P_p^\Delta(\xi_1)} \right] \quad (\text{A.37})$$

$$J_{p1}^{II} = -J_{p1}^I Q_p^1(\xi_2) / P_p^1(\xi_2) \quad (\text{A.38})$$

$$[A] = Q_p^1(\xi_4) / P_p^1(\xi_4) \quad (\text{A.39})$$

$$[C] = Q_p^\Delta(\xi_4) / P_p^\Delta(\xi_4) \quad (\text{A.40})$$

$$[H] = Q_p^1(\xi_3) / P_p^1(\xi_3) \quad (\text{A.41})$$

$$J_{p2}^I = \frac{\mu_1 J_{p2}(\theta) a(\xi_4^2 - v^2)^{\frac{1}{2}}}{P_p^\Delta(\xi_4) P_p^1(v)} \quad (\text{A.42})$$

$$J_{p2}^{II} = J_{p2}^I / [A] - [C] \quad (\text{A.43})$$

$$J_{p1}^{III} = \frac{\left(\frac{1}{\mu_1}\right) J_{p1}^I Q_p^\Delta(\xi_2) + \left(\frac{1}{\mu_1}\right) J_{p1}^{II} P_p^\Delta(\xi_2)}{\left[\left(-\frac{1}{\mu_1}\right) [S] P_p^\Delta(\xi_2) + \left(\frac{1}{\mu_2}\right) P_p^\Delta(\xi_2) + \left(\frac{1}{\mu_2}\right) [Q] Q_p^\Delta(\xi_2) \right]} \quad (\text{A.44})$$

$$[U] = \frac{\left(-\frac{1}{\mu_1}\right) [Z] P_p^\Delta(\xi_2) + \left(\frac{1}{\mu_2}\right) [R] Q_p^\Delta(\xi_2)}{\left[\left(-\frac{1}{\mu_1}\right) [S] P_p^\Delta(\xi_2) + \left(\frac{1}{\mu_2}\right) P_p^\Delta(\xi_2) + \left(\frac{1}{\mu_2}\right) [Q] Q_p^\Delta(\xi_2) \right]} \quad (\text{A.45})$$

APPENDIX B

DETERMINATION OF THE MAGNETIC VECTOR POTENTIAL FOR AN INFINITESIMALLY THIN PROLATE SPHEROIDAL CURRENT BAND

In this appendix, the potentials $A_{\psi I}$ in the inner region and $A_{\psi II}$ in the outer region are derived for the infinitesimally thin current band in a homogeneous medium of permeability μ_1 (Figure B.1).

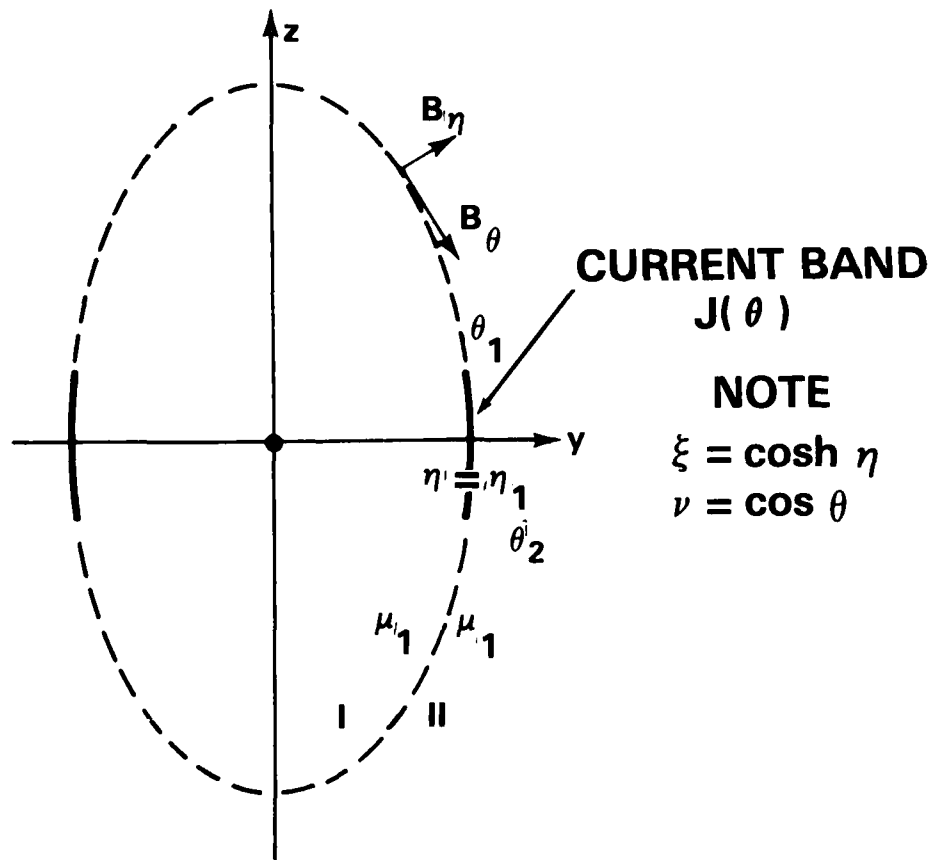

Figure B.1 - Infinitesimally Thin Spheroidal Current Band

The potential in the inner region $A_{\psi I}$ and the outer region $A_{\psi II}$ of the infinitesimally thin current band problem are solutions to the vector Laplace's equation $\nabla^2 \bar{A}_{\psi} = 0$. These solutions can be expressed as:

$$A_{\psi I} = \sum_{p=1}^{\infty} [A_p P_p^1(\xi)] P_p^1(\nu) \quad (\text{B.1a})$$

$$A_{\psi II} = \sum_{p=1}^{\infty} [F_p Q_p^1(\xi)] P_p^1(\nu) \quad (\text{B.1b})$$

The coefficients A_p and F_p are determined from the boundary conditions of the problem. After algebraic manipulation such as with Equations (32) and (40) in the text, the boundary conditions for the normal component of \bar{B} and the tangential component of \bar{H} become:

$$A_I = A_{II} \text{ at } \eta_1 = \eta_1 \quad (\text{B.2a})$$

$$\begin{aligned} & -\left(\frac{1}{\mu_1}\right) \left[\frac{1}{a(\xi_1^2 - \nu^2)^{1/2}} \frac{\partial}{\partial \xi} \left[(\xi^2 - 1)^{1/2} A_{II} \right] \right] \Bigg|_{\xi=\xi_1} \\ & + \left(\frac{1}{\mu_1}\right) \left[\frac{1}{a(\xi_1^2 - \nu^2)^{1/2}} \frac{\partial}{\partial \xi} \left[(\xi^2 - 1)^{1/2} A_I \right] \right] \Bigg|_{\xi=\xi_1} = J_{\psi}(\theta) \quad (\text{B.2b}) \end{aligned}$$

Using the relationship $\xi = \cosh \eta$ and $\nu = \cos \theta$ and substituting the expressions for $A_{\psi I}$ and $A_{\psi II}$ (Equations (B.1a) and (B.1b)) into the boundary

value equations (Equations (B.2a) and B.2b)) provides us with the following algebraic equations for the coefficients

$$A_p P_p^1(\xi_1) = F_p Q_p^1(\xi_1) \quad (\text{B.3a})$$

$$-\frac{1}{\mu_1} [F_p Q_p^\Delta(\xi_1)] + \frac{1}{\mu_1} [A_p P_p^\Delta(\xi_1)] = \frac{J_p(\theta) a(\xi_1^2 - v^2)^{\frac{1}{2}}}{P_p^1(v)} \quad (\text{B.3b})$$

where the following substitutions were used

$$P_p^\Delta(\xi) = \frac{\partial}{\partial \xi} [(\xi^2 - 1)^{\frac{1}{2}} P_p^1(\xi)] \quad (\text{B.4})$$

$$Q_p^\Delta(\xi) = \frac{\partial}{\partial \xi} [(\xi^2 - 1)^{\frac{1}{2}} Q_p^1(\xi)] \quad (\text{B.5})$$

These equations are solved for A_p and F_p by simple algebraic manipulations

$$A_p = F_p \frac{Q_p^1(\xi_1)}{P_p^1(\xi_1)} \quad (\text{B.6a})$$

$$F_p = \left[\frac{\mu_1 J_p(\theta) a(\xi_1^2 - v^2)^{\frac{1}{2}}}{P_p^\Delta(\xi_1) P_p^1(v)} \right] / \left[\frac{Q_p^1(\xi_1)}{P_p^1(\xi_1)} - \frac{Q_p^\Delta(\xi_1)}{P_p^\Delta(\xi_1)} \right] \quad (\text{B.6b})$$

The potential $A_{\psi I}$ and $A_{\psi II}$ are determined by substituting the expression for A_p and F_p into Equations (B.1a) and (B.1b).

$$A_{\psi I} = \sum_{p=1}^{\infty} \left\{ \left[\frac{\mu_1 J_p(\theta) a(\xi_1^2 - v^2)^{\frac{1}{2}}}{P_p^{\Delta}(\xi_1) P_p^1(v)} \left(\frac{Q_p^1(\xi_1)}{P_p^1(\xi_1)} \right) \right] / \left[\frac{Q_p^1(\xi_1)}{P_p^1(\xi_1)} - \frac{Q_p^{\Delta}(\xi_1)}{P_p^{\Delta}(\xi_1)} \right] \right\} \\ \times P_p^1(\xi) P_p^1(v) \quad (B.7a)$$

$$A_{\psi II} = \sum_{p=1}^{\infty} \left\{ \frac{\mu_1 J_p(\theta) a(\xi_1^2 - v^2)^{\frac{1}{2}}}{P_p^{\Delta}(\xi_1) P_p^1(v)} / \left[\frac{Q_p^1(\xi_1)}{P_p^1(\xi_1)} - \frac{Q_p^{\Delta}(\xi_1)}{P_p^{\Delta}(\xi_1)} \right] \right\} Q_p^1(\xi) P_p^1(v) \quad (B.7b)$$

where

$$J_p(\theta) = \frac{JG_p P_p^1(v)}{a(\xi_1^2 - v^2)^{\frac{1}{2}}} \quad (B.8)$$

APPENDIX C

REDUCTION OF THE MAGNETIC VECTOR POTENTIAL FOR A FERROMAGNETIC
 PROLATE SPHEROIDAL SHELL, SURROUNDING AND SURROUNDED BY
 INFINITESIMALLY THIN CURRENT BANDS, TO THAT OF A THIN
 COIL IN FREE SPACE WHEN THE INTERNAL CURRENT DENSITY
 $[J_1(\theta)]$ IS ZERO AND IN THE LIMIT μ_2 EQUALS μ_1

In this appendix, the coefficients $A_p, B_p, C_p, D_p, E_p, F_p, G_p,$ and $H_p,$ for the potentials are calculated for the system consisting of a ferromagnetic shell of permeability μ_2 with internal and external current bands in a homogeneous medium with permeability μ_1 when the internal current density $[J_1(\theta)]$ is set equal to zero and the limit is taken as $\mu_2 = \mu_1$. These coefficients are utilized in Equation (30) in the body of this report. The variables are defined in Figure 2 of the text. When $J_1(\theta)$ is set equal to zero and μ_2 is set equal to μ_1 , the problem reduces to that of finding the potential in the two regions of a simple current band (Figure B.1 in Appendix B), because the ferromagnetic shell will now have a permeability μ_1 equal to that of the homogeneous medium with permeability μ_1 .

In this limit, the coefficients should assume the following form

$$A_p = B_p = D_p = F_p \quad (C.1a)$$

$$C_p = E_p = G_p = 0 \quad (C.1b)$$

and H_p and F_p should reduce to the coefficients for the potentials in the two regions for the prolate spheroidal band problem (see Appendix B). If the coefficients assume this mathematical form, it will prove that the mathematical form of the coefficients for the prolate spheroidal shell with the external coil are mathematically correct.

The mathematical solution for G_p in terms of known quantities was derived in Appendix A and was reported in the text (Equation (44h)).

$$G_p = \frac{-J_{p1}^{III} [Q] [H] - J_{p1}^{III} + J_{p2}^{II} [A]}{[U] [Q] [H] - [R] [H] - [H] + [U]} \quad (C.2a)$$

where

$$J_{p1}^{III} = \frac{\left(\frac{1}{\mu_1}\right) J_{p1}^I Q_p^\Delta(\xi_2) + \left(\frac{1}{\mu_1}\right) J_{p1}^{II} P_p^\Delta(\xi_2)}{\left[\left(-\frac{1}{\mu_1}\right) [S] P_p^\Delta(\xi_2) + \left(\frac{1}{\mu_2}\right) P_p^\Delta(\xi_2) + \left(\frac{1}{\mu_2}\right) [Q] Q_p^\Delta(\xi_2)\right]} \quad (C.2b)$$

$$J_{p2}^{II} = J_{p2}^I / \{[A] - [C]\} \quad (C.2c)$$

$$[H] = Q_p^1(\xi_3) / P_p^1(\xi_3) \quad (C.2d)$$

$$[U] = \frac{\left(-\frac{1}{\mu_1}\right) [Z] P_p^\Delta(\xi_2) + \left(\frac{1}{\mu_2}\right) [R] Q_p^\Delta(\xi_2)}{\left[\left(-\frac{1}{\mu_1}\right) [S] P_p^\Delta(\xi_2) + \left(\frac{1}{\mu_2}\right) P_p^\Delta(\xi_2) + \left(\frac{1}{\mu_2}\right) [Q] Q_p^\Delta(\xi_2)\right]} \quad (C.2e)$$

$$[Q] = \left(\frac{\mu_1}{\mu_2} - 1\right) / \left[\frac{Q_p^1(\xi_3)}{P_p^1(\xi_3)} - \left(\frac{\mu_1}{\mu_2}\right) \frac{Q_p^\Delta(\xi_3)}{P_p^\Delta(\xi_3)}\right] \quad (C.2f)$$

$$[R] = \left[\frac{Q_p^\Delta(\xi_3)}{P_p^\Delta(\xi_3)} - \frac{Q_p^1(\xi_3)}{P_p^1(\xi_3)}\right] / \left[\frac{Q_p^1(\xi_3)}{P_p^1(\xi_3)} - \left(\frac{\mu_1}{\mu_2}\right) \frac{Q_p^\Delta(\xi_3)}{P_p^\Delta(\xi_3)}\right] \quad (C.2g)$$

$$[A] = Q_p^1(\xi_4) / P_p^1(\xi_4) \quad (C.2h)$$

$$[S] = \left[1 + [Q] \frac{Q_p^1(\xi_2)}{P_p^1(\xi_2)} \right] \quad (C.2i)$$

$$[Z] = \left[[R] \frac{Q_p^1(\xi_2)}{P_p^1(\xi_2)} \right] \quad (C.2j)$$

$$J_{p2}^I = \frac{\mu_1 J_{p2}(\theta) a(\xi_4^2 - v^2)^{1/2}}{P_p^\Delta(\xi_4) P_p^1(v)} \quad (C.2k)$$

The coefficient G_p will now be evaluated when $J_1(\theta) = 0$ and the limit is taken with $\mu_2 = \mu_1$. When $J_1(v) = 0$

$$J_{p1}^{III} = J_{p1}^{II} = J_{p1}^I = 0 \quad (C.3)$$

and G_p reduces to

$$G_p \Big|_{J_1(\theta)=0} = \frac{J_{p2}^{II} [A]}{[U] [Q] [H] - [R] [H] - [H] + [V]} \quad (C.4)$$

When $\mu_2 \rightarrow \mu_1$

$$\lim_{\mu_2 \rightarrow \mu_1} [Q] = 0 \quad (C.5)$$

$$\lim_{\mu_2 \rightarrow \mu_1} [S] = 1 \quad (C.6)$$

$$\lim_{\mu_2 \rightarrow \mu_1} [U] [Q] [H]$$

$$= \frac{\left\{ \left(\frac{Q_p^1(\xi_2)}{P_p^1(\xi_2)} - \frac{Q_p^\Delta(\xi_2)}{P_p^\Delta(\xi_2)} \right) \frac{Q_p^1(\xi_3)}{P_p^1(\xi_3)} \right\}}{\left\{ \frac{Q_p^1(\xi_3)}{P_p^1(\xi_3)} - \frac{Q_p^\Delta(\xi_3)}{P_p^\Delta(\xi_3)} - \frac{Q_p^1(\xi_2)}{P_p^1(\xi_2)} + \frac{Q_p^\Delta(\xi_2)}{P_p^\Delta(\xi_2)} \right\}} \quad (C.7)$$

$$\lim_{\mu_2 \rightarrow \mu_1} [R] [H] = \left\{ \left(\frac{Q_p^\Delta(\xi_3)}{P_p^\Delta(\xi_3)} - \frac{Q_p^1(\xi_3)}{P_p^1(\xi_3)} \right) / \left(\frac{Q_p^1(\xi_3)}{P_p^1(\xi_3)} - \frac{Q_p^\Delta(\xi_3)}{P_p^\Delta(\xi_3)} \right) \right\} \frac{Q_p^1(\xi_3)}{P_p^1(\xi_3)}$$

$$= - [H] = - \frac{Q_p^1(\xi_3)}{P_p^1(\xi_3)} \quad (C.8)$$

$$\lim_{\mu_2 \rightarrow \mu_1} [U] = \infty \quad (C.9)$$

therefore

$$\boxed{G_p \Big|_{\mu_2 \rightarrow \mu_1} = 0} \quad (C.10)$$

Now, because

$$F_p = H_p [A] - G_p [A] \quad (C.11)$$

$$F_p \Big|_{\mu_2=\mu_1} = H_p \Big|_{\mu_2=\mu_1} [A] \quad (C.12)$$

where

$$[A] = \frac{Q_p^1(\xi_4)}{P_p^1(\xi_4)} \quad (C.13)$$

Also

$$H_p = G_p + J_{p2}^{II} \quad (C.14)$$

$$H_p \Big|_{\mu_2=\mu_1} = J_{p2}^{II} = \frac{\left[\frac{\mu_1 J_{p2}(\theta) a(\xi_4^2 - v^2)^{\frac{1}{2}}}{P_p^\Delta(\xi_4) P_p^1(v)} \right]}{\left[\frac{Q_p^1(\xi_4)}{P_p^1(\xi_4)} - \frac{Q_p^\Delta(\xi_4)}{P_p^\Delta(\xi_4)} \right]} \quad (C.15)$$

Therefore

$$F_p \Big|_{\mu_2=\mu_1} = \left[\frac{\mu_1 J_{p2}(\theta) a(\xi_4^2 - v^2)^{\frac{1}{2}}}{P_p^\Delta(\xi_4) P_p^1(v)} \left(\frac{Q_p^1(\xi_4)}{P_p^1(\xi_4)} \right) \right] / \left[\frac{Q_p^1(\xi_4)}{P_p^1(\xi_4)} - \frac{Q_p^\Delta(\xi_4)}{P_p^\Delta(\xi_4)} \right] \quad (C.16)$$

We have

$$C_p \left| \begin{array}{c} \\ \mu_2 = \mu_1 \end{array} \right| = 0 \quad (C.17)$$

because

$$C_p = J_{p1}^I \text{ and } J_{p1}^I \left| \begin{array}{c} \\ J_1(\theta)=0 \end{array} \right| = 0 \quad (C.18)$$

Also

$$A_p = B_p + C_p \frac{Q_p^1(\xi_1)}{P_p^1(\xi_1)} \quad (C.19)$$

using Equation (C.17) we have

$$A_p \left| \begin{array}{c} \\ \mu_2 = \mu_1 \end{array} \right| = B_p \left| \begin{array}{c} \\ \mu_2 = \mu_1 \end{array} \right| \quad (C.20)$$

We also had

$$E_p = D_p [Q] - G_p [R] \quad (C.21)$$

using Equations (C.5) and (C.10)

$$E_p \left| \begin{array}{c} \\ \mu_2 = \mu_1 \end{array} \right| = 0 \quad (C.22)$$

Now, F_p could be expressed as

$$F_p = E_p [H] - G_p [H] + D_p \quad (C.23)$$

and, using Equations (C.10) and (C.22), we have

$$F_p \Big|_{\mu_2=\mu_1} = D_p \Big|_{\mu_2=\mu_1} = \left[\frac{\mu_1 J_{p2}(\theta) a(\xi_4^2 - v^2)^{\frac{1}{2}}}{P_p^\Delta(\xi_4) P_p^1(v)} \left(\frac{Q_p^1(\xi_4)}{P_p^1(\xi_4)} \right) \right] / \left[\frac{Q_p^1(\xi_4)}{P_p^1(\xi_4)} - \frac{Q_p^\Delta(\xi_4)}{P_p^\Delta(v_4)} \right] \quad (C.24)$$

A derived expression for B_p was

$$B_p = J_{p1}^{II} + D_p [S] - G_p [Z] \quad (C.25)$$

and, using Equations (C.3), (C.6), and (C.10), we have

$$B_p \Big|_{\mu_2=\mu_1} = D_p \Big|_{\mu_2=\mu_1} \quad (C.26)$$

Thus we have

$$A_p \Big|_{\mu_2=\mu_1} = B_p \Big|_{\mu_2=\mu_1} = D_p \Big|_{\mu_2=\mu_1} = F_p \Big|_{\mu_2=\mu_1} \quad (C.27)$$

with

$$F_p \Big|_{\mu_2=\mu_1} = \left[\frac{\mu_1 J_{p2}(\theta) a(\xi_4^2 - v^2)^{\frac{1}{2}}}{P_p^\Delta(\xi_4) P_p^1(v)} \left(\frac{Q_p^1(\xi_4)}{P_p^1(\xi_4)} \right) \right] / \left[\frac{Q_p^1(\xi_4)}{P_p^1(\xi_4)} - \frac{Q_p^\Delta(\xi_4)}{P_p^\Delta(v_4)} \right]$$

$$= H_p \Big|_{\mu_2=\mu_1} \left(\frac{Q_p^1(\xi_4)}{P_p^1(\xi_4)} \right) \quad (C.28)$$

and

$$C_p = E_p = G_p = 0 \quad (C.29)$$

and

$$H_p \Big|_{\mu_2=\mu_1} = \left[\frac{\mu_1 J_{p2}(\theta) a(\xi_4^2 - \nu^2)^{\frac{1}{2}}}{P_p^\Delta(\xi_4) P_p^1(\nu)} \right] \left[\begin{array}{cc} Q_p^1(\xi_4) & Q_p^\Delta(\xi_4) \\ P_p^1(\xi_4) & P_p^\Delta(\xi_4) \end{array} \right] \quad (C.30)$$

Now, Equation (30) reduces to

$$A_{\psi I} = A_{\psi II} = A_{\psi III} = A_{\psi IV} = \sum_{p=1}^{\infty} \left[A_p \Big|_{\mu_2=\mu_1} \right] P_p^1(\xi) P_p^1(\nu) \quad (C.31)$$

$$A_{\psi V} = \sum_{p=1}^{\infty} \left[H_p \Big|_{\mu_2=\mu_1} \right] Q_p^1(\xi) P_p^1(\nu) \quad (C.32)$$

comparing Equations (C.31) and (C.32) to Equations (B.1a) and (B.1b),

which are repeated for convenience as and using a primed notation

$$A'_{\psi I} = \sum_{p=1}^{\infty} A'_p P_p^1(\xi) P_p^1(\nu) \quad (C.33a)$$

$$A'_{\psi II} = \sum_{p=1}^{\infty} F'_p Q_p^1(\xi) P_p^1(\nu) \quad (C.33b)$$

where

$$A'_p = F'_p \frac{Q_p^1(\xi_1)}{P_p^1(\xi_1)} \quad (C.34)$$

$$F'_p = \left[\frac{\mu_1 J_p(\theta) a(\xi_1^2 - v^2)^{1/2}}{P_p^\Delta(\xi_1) P_p^1(v)} \right] / \left[\frac{Q_p^1(\xi_1)}{P_p^1(\xi_1)} - \frac{Q_p^\Delta(\xi_1)}{P_p^\Delta(\xi_1)} \right] \quad (C.35)$$

Thus

$$A'_p = F_p \Big|_{\mu_2=\mu_1} \quad \text{or} \quad A'_p = A_p \Big|_{\mu_2=\mu_1} \quad (\text{see Equation (C.27)})$$

$$\text{with } \xi_1 = \xi_4, J_p(\theta) = J_{p2}(\theta) \quad (C.36)$$

$$F'_p = H_p \Big|_{\mu_2=\mu_1} \quad \text{with } \xi_1 = \xi_4, J_p(\theta) = J_{p2}(\theta) \quad (C.37)$$

Therefore, in the limit $\mu_2 \rightarrow \mu_1$ and with $J_{p1}(\theta) = 0$

$$A_{\psi I} = A_{\psi II} = A_{\psi III} = A_{\psi IV} = A'_{\psi I} \quad (C.38)$$

$$A_{\psi V} = A'_{\psi II} \quad (C.39)$$

APPENDIX D

REDUCTION OF THE MAGNETIC VECTOR POTENTIAL FOR A FERROMAGNETIC
 PROLATE SPHEROIDAL SHELL, SURROUNDING AND SURROUNDED BY
 INFINITESIMALLY THIN CURRENT BANDS, TO THAT OF A THIN
 COIL IN FREE SPACE WHEN THE EXTERNAL CURRENT DENSITY
 $[J_2(\theta)]$ IS ZERO AND IN LIMIT μ_2 EQUALS μ_1

In this appendix, the coefficients A_p , B_p , C_p , D_p , E_p , F_p , G_p , and H_p for the potentials are calculated for the system consisting of a ferromagnetic shell of permeability μ_2 with internal and external current bands in a homogeneous medium with permeability μ_1 when the external current density $[J_2(\theta)]$ is set equal to zero and the limit is taken as $\mu_2 = \mu_1$. These coefficients are utilized in Equation (30) in the text. The variables are defined in Figure 2 of the text. When $J_2(\theta)$ is set equal to zero and μ_2 is set equal to μ_1 , the problem reduces to that of finding the potential in the two regions of a simple current band (Figure B.1 in Appendix B), since the ferromagnetic shell will now have a permeability μ_1 equal to that of the homogeneous medium with permeability μ_1 .

In this limit, the coefficients should assume the following form

$$B_p = D_p = F_p = 0 \quad (D.1a)$$

$$C_p = E_p = G_p = H_p \quad (D.1b)$$

and where A_p and C_p should reduce to the coefficients for the potentials in the two regions for the prolate spheroidal band problem (see Appendix B). If the coefficients assume this mathematical form, it will prove that the mathematical form of the coefficients for the prolate spheroidal shell with the internal coil are mathematically correct.

The mathematical solution for G_p in terms of known quantities was derived in Appendix A and was reported in the text (Equation (44h)).

$$G_p = \frac{-J_{p1}^{III} [Q] [H] - J_{p1}^{III} + J_{p2}^{II} [A]}{[U] [Q] [H] - [R] [H] - [H] + [U]} \quad (D.2a)$$

where

$$J_{p1}^{III} = \frac{\left(\frac{1}{\mu_1}\right) J_{p1}^I Q_p^\Delta(\xi_2) + \left(\frac{1}{\mu_1}\right) J_{p1}^{II} P_p^\Delta(\xi_2)}{\left[\left(-\frac{1}{\mu_1}\right) [S] P_p^\Delta(\xi_2) + \left(\frac{1}{\mu_2}\right) P_p^\Delta(\xi_2) + \left(\frac{1}{\mu_2}\right) [Q] Q_p^\Delta(\xi_2)\right]} \quad (D.2b)$$

$$J_{p2}^{II} = J_{p2}^I / \{[A] - [C]\} \quad (D.2c)$$

$$[H] = Q_p^1(\xi_3) / P_p^1(\xi_3) \quad (D.2d)$$

$$[U] = \frac{\left(-\frac{1}{\mu_1}\right) [Z] P_p^\Delta(\xi_2) + \left(\frac{1}{\mu_2}\right) [R] Q_p^\Delta(\xi_2)}{\left[\left(-\frac{1}{\mu_1}\right) [S] P_p^\Delta(\xi_2) + \left(\frac{1}{\mu_2}\right) P_p^\Delta(\xi_2) + \left(\frac{1}{\mu_2}\right) [Q] Q_p^\Delta(\xi_2)\right]} \quad (D.2e)$$

$$[Q] = \left(\frac{\mu_1}{\mu_2} - 1\right) / \left[\frac{Q_p^1(\xi_3)}{P_p^1(\xi_3)} - \left(\frac{\mu_1}{\mu_2}\right) \frac{Q_p^\Delta(\xi_3)}{P_p^\Delta(\xi_3)}\right] \quad (D.2f)$$

$$[R] = \left[\frac{Q_p^\Delta(\xi_3)}{P_p^\Delta(\xi_3)} - \frac{Q_p^1(\xi_3)}{P_p^1(\xi_3)}\right] / \left[\frac{Q_p^1(\xi_3)}{P_p^1(\xi_3)} - \left(\frac{\mu_1}{\mu_2}\right) \frac{Q_p^\Delta(\xi_3)}{P_p^\Delta(\xi_3)}\right] \quad (D.2g)$$

$$[A] = Q_p^1(\xi_4) / P_p^1(\xi_4) \quad (D.2h)$$

$$[S] = \left[1 + [Q] \frac{Q_p^1(\xi_2)}{P_p^1(\xi_2)}\right] \quad (D.2i)$$

$$[Z] = \left[[R] \frac{Q_p^1(\xi_2)}{P_p^1(\xi_2)} \right] \quad (D.2j)$$

$$J_{p2}^I = \frac{\mu_1 J_{p2}(\theta) a(\xi_4^2 - v^2)^{\frac{1}{2}}}{P_p^\Delta(\xi_4) P_p^I(v)} \quad (D.2k)$$

The coefficient G_p will now be evaluated when $J_2(\theta) = 0$ and the limit is taken with $\mu_2 = \mu_1$. When $J_{p2}(\theta) = 0$

$$J_{p2}^{II} = 0 \quad (D.3)$$

and G_p reduces to

$$G_p = \frac{-J_{p1}^{III} [Q] [H] - J_{p1}^{III}}{[U] [Q] [H] - [R] [H] - [H] + [U]} \quad (D.4)$$

Now, divide numerator and denominator by [U] and when $\mu_2 \rightarrow \mu_1$

$$\lim_{\mu_2 \rightarrow \mu_1} \frac{J_{p1}^{III}}{[U]} = \frac{J_{p1}^I \frac{Q_p^\Delta(\xi_2)}{P_p^1(\xi_2)} - J_{p1}^I \frac{Q_p^1(\xi_2) P_p^\Delta(\xi_2)}{P_p^1(\xi_2)}}{\left[P_p^\Delta(\xi_2) \frac{Q_p^1(\xi_2)}{P_p^1(\xi_2)} - Q_p^\Delta(\xi_2) \right]} = -J_{p1}^I \quad (D.5)$$

$$\lim_{\mu_2 \rightarrow \mu_1} [R] = -1 \quad (D.6)$$

$$\lim_{\mu_2 \rightarrow \mu_1} [Q] = 0 \quad (D.7)$$

$$\lim_{\mu_2 \rightarrow \mu_1} [U] = \infty \quad (D.8)$$

$$\lim_{\mu_2 \rightarrow \mu_1} \frac{J_{p1}^{III} [Q] [H]}{[U]} = 0 \quad (D.9)$$

Thus

$$G_p \Big|_{\mu_2 = \mu_1} = \left[\frac{\mu_1 J_{p1}(\theta) a(\xi_1^2 - v^2)^{1/2}}{P_p^I(v) P_p^\Delta(\xi_1)} \right] / \left[\frac{Q_p^1(\xi_1)}{P_p^I(\xi_1)} - \frac{Q_p^\Delta(\xi_1)}{P_p^\Delta(\xi_1)} \right] = J_{p1}^I \quad (D.10)$$

Now, because

$$E_p = D_p [Q] - G_p [R] \quad (D.11)$$

and using Equations (D.6) and (D.7), we have

$$E_p \Big|_{\mu_2 = \mu_1} = G_p \Big|_{\mu_2 = \mu_1} = J_{p1}^I \quad (D.12)$$

Because, by definition (see Equation A.8)

$$C_p = J_{p1}^I \quad (D.13)$$

then $E_p = G_p = C_p$ when $\mu_2 = \mu_1$. Also

$$H_p = G_p + J_{p2}^{II} \quad (D.14)$$

and because J_{p2}^{II} equals zero when $J_{p2}(\theta) = 0$, then

$$H_p \Big|_{\mu_2=\mu_1} = G_p \Big|_{\mu_2=\mu_1} = J_{p1}^I \quad (D.15)$$

Therefore

$$C_p \Big|_{\mu_2=\mu_1} = E_p \Big|_{\mu_2=\mu_1} = G_p \Big|_{\mu_2=\mu_1} = H_p \Big|_{\mu_2=\mu_1} = J_{p1}^I \quad (D.16)$$

We have

$$F_p = H_p [A] - G_p [A] \quad (D.17)$$

and, using Equation (D.16)

$$F_p \Big|_{\mu_2=\mu_1} = 0 \quad (D.18)$$

D_p can be found using the following equation

$$F_p = E_p \frac{Q_p^1(\xi_3)}{P_p^1(\xi_3)} - G_p \frac{Q_p^1(\xi_3)}{P_p^1(\xi_3)} + D_p \quad (D.19)$$

and by using Equations (D.16) and (D.17)

$$D_p \Big|_{\mu_2=\mu_1} = 0 \quad (D.20)$$

In addition

$$B_p = J_{p1}^{II} + D_p [S] - G_p [Z] \quad (D.21)$$

Using

$$\lim_{\mu_2 \rightarrow \mu_1} [Z] = - \frac{Q_p^1(\xi_2)}{P_p^1(\xi_2)} \quad (D.22)$$

$$\lim_{\mu_2 \rightarrow \mu_1} [S] = 1 \quad (D.23)$$

$$J_{p1}^{II} = - J_{p1}^I \frac{Q_p^1(\xi_2)}{P_p^1(\xi_2)} \quad (D.24)$$

and Equations (D.16) and (D.20), it is easily shown that

$$B_p \Big|_{\mu_2 \rightarrow \mu_1} = 0 \quad (D.25)$$

Thus, we have

$$D_p = B_p = F_p = 0 \text{ when } \mu_2 = \mu_1 \quad (D.26)$$

The coefficient A_p was expressed as

$$A_p = B_p + C_p \frac{Q_p^1(\xi_1)}{P_p^1(\xi_1)} \quad (D.27)$$

$$A_p \left| \begin{array}{c} \\ \mu_2 = \mu_1 \end{array} \right| = C_p \left| \begin{array}{c} \\ \mu_2 = \mu_1 \end{array} \right| \frac{Q_p^1(\xi_1)}{P_p^1(\xi_1)} = J_{p1}^I \frac{Q_p^1(\xi_1)}{P_p^1(\xi_1)} \quad (D.28)$$

Now, Equations (30) reduce to

$$A_{\psi I} = \sum_{p=1}^{\infty} \left[A_p \left| \begin{array}{c} \\ \mu_2 = \mu_1 \end{array} \right| \right] P_p^1(\xi) P_p^1(\nu) \quad (D.29)$$

$$A_{\psi II} = A_{\psi III} = A_{\psi IV} = A_{\psi V} = \sum_{p=1}^{\infty} \left[H_p \left| \begin{array}{c} \\ \mu_2 = \mu_1 \end{array} \right| \right] Q_p^1(\xi) P_p^1(\nu) \quad (D.30)$$

Comparing Equations (D.29) and (D.30) to Equations (B.1a) and (B.1b), which are repeated for convenience, and using a primed notation

$$A'_{\psi I} = \sum_{p=1}^{\infty} A'_p P_p^1(\xi) P_p^1(\nu) \quad (D.31)$$

$$A'_{\psi II} = \sum_{p=1}^{\infty} F'_p Q_p^1(\xi) P_p^1(\nu) \quad (D.32)$$

where

$$A'_p = F'_p \frac{Q_p^1(\xi_1)}{P_p^1(\xi_1)} \quad (D.33)$$

$$F'_p = \left[\frac{\mu_1 J_p(\theta) a(\xi_1^2 - \nu^2)^{\frac{1}{2}}}{P_p^\Lambda(\xi_1) P_p^I(\nu)} \right] / \left[\frac{Q_p^1(\xi_1)}{P_p^1(\xi_1)} - \frac{Q_p^\Lambda(\xi_1)}{P_p^\Lambda(\xi_1)} \right] \quad (D.34)$$

Thus

$$A'_p = A_p \Big|_{\mu_2 = \mu_1} \quad \text{with } J_p(\theta) = J_{p1}(\theta) \quad (\text{D.35})$$

$$F'_p = C_p \Big|_{\mu_2 = \mu_1} \quad \text{with } J_p(\theta) = J_{p1}(\theta) \quad (\text{D.36})$$

Therefore, in the limit $\mu_2 = \mu_1$ and with $J_{p2}(\theta) = 0$,

$$A_{\psi I} = A'_{\psi I} \quad (\text{D.37})$$

$$A_{\psi II} = A_{\psi III} = A_{\psi IV} = A_{\psi V} = A'_{\psi II} \quad (\text{D.38})$$

REFERENCES

1. Brown, S.H., and F. E. Baker, Jr., "The Magnetic Induction of the System Consisting of a Coil and a Ferromagnetic Spherical Body," DTNSRDC Rept PAS-78-35 (Mar 1979).
2. Brown, S.H., and F.E. Baker, Jr. "The Magnetic Induction of the System Consisting of a Coil and Ferromagnetic Prolate Spheroidal Shell," DTNSRDC Rept 79/096 (Dec 1979).
3. Moon, P., and D.E. Spencer, Field Theory for Engineers, Springer-Verlag, Berlin (1961).
4. Flammer, C., Spheroidal Wave Functions, Stanford University Press, Stanford, CA (1957).

INITIAL DISTRIBUTION

Copies		CENTER DISTRIBUTION		
		Copies	Code	Name
1	NRL Code 5294 (Mr. R. Clement)	1	2704	W.J. Andahazy
2	NAVMAT	15	2704	F.E. Baker
	1 PM2-21 (Mr. W. Welsh)			
	1 PM2-2001 (Mr. J. Crone)	10	2704	P.T. Fields
2	NUSC/NL	2	273	
	1 Code 401 (Mr. J. Frye)			
	1 Code 401 (Dr. R. Kasper)	10	2731	S.H. Brown
1	NCSC Code 792 (Dr. W. Michael Wynn)	1	2734	B.R. Hood
3	NSWC/WO	1	2734	D.A. Nixon
	1 Code E22 (Mr. K. Bishop)			
	1 Code R43 (Mr. M. Kraichman)	1	2734	F.B. Walker
	1 Code E22 (Dr. J. Holmes)	10	5211.1	
2	NAVPGSCPL Code 023 (Dr. R. R. Fossum)	1	522.1	
12	DTIC	1	522.2	
2	University of Pennsylvania (Dr. R. Showers)	2	5231	
1	Stanford Electronics Laboratory Stanford University (Dr. A. C. Fraser-Smith)			
2	Vanderbilt University (Dr. J. Wikswow, Jr.)			
1	Science Applications, Inc. (Dr. J. Czika)			

