

AD-A082 764

MITRE CORP MCLEAN VA METREK DIV F/G 17/7  
NAFEC AIR TRAFFIC CONTROL (ATC) FACILITIES PLANNING: CURRENT CA--ETC(U)  
FEB 80 D J SWEENEY, R A AMATO, H S GABRIELI DOT-FA79NA-6013  
MTR-80N00001 FAA-NA-80-160 NL

UNCLASSIFIED

1 of 2

40  
AD-80-764

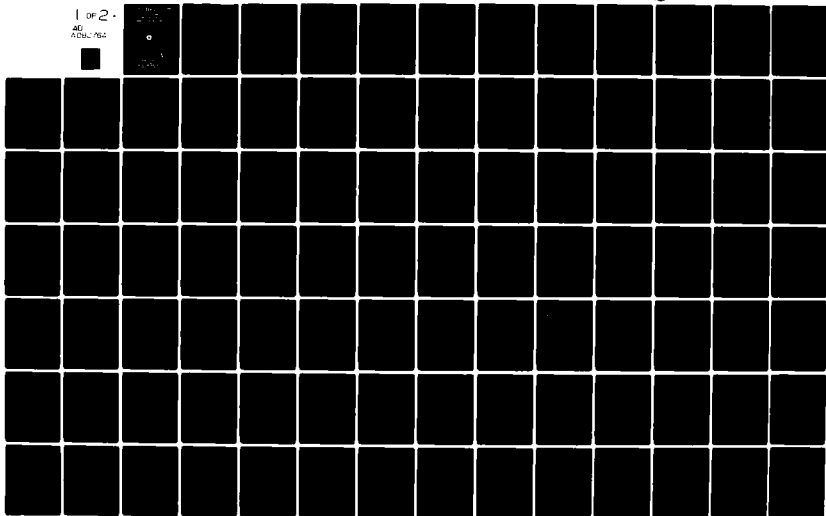

Report No. FAA-NA-89-160

**LEVEL II**

MTR-89N00001

5  
15

**NAFEC ATC FACILITIES PLANNING:  
CURRENT CAPABILITIES AND  
REQUIREMENTS FOR LONG-TERM DEVELOPMENT**

ADA 082764

The MITRE Corporation  
Metrek Division  
McLean, Virginia 22102



FEBRUARY 1980

Document is available to the U.S. public through  
the National Technical Information Service,  
Springfield, Virginia 22161.

DTIC  
ELECTE  
APR 8 1980  
S D  
E

**U. S. DEPARTMENT OF TRANSPORTATION  
FEDERAL AVIATION ADMINISTRATION  
National Aviation Facilities Experimental Center  
Atlantic City, New Jersey 08405**

DDG FILE COPY

80 4 7 177

NOTICE

This document is disseminated under the sponsorship of the Department of Transportation in the interest of information exchange. The United States Government assumes no liability for its contents or use thereof.

1. Report No. FAA-NA-80-160		2. Government Accession No.		3. Recipient's Catalog No. 12 131	
4. Title and Subtitle NAFEC ATC FACILITIES PLANNING: CURRENT CAPABILITIES AND REQUIREMENTS FOR LONG-TERM DEVELOPMENT.				5. Report Date FEBRUARY 1980	
				6. Performing Organization Code	
7. Author(s) D. J. Sweeney, R. A. Amato, H. S. Gabrieli				8. Performing Organization Report No. MTR-80N00001	
				10. Work Unit No. (TRAIS)	
9. Performing Organization Name and Address The MITRE Corporation Metrek Division 1820 Dolley Madison Blvd. McLean, VA 22102				11. Contract or Grant No. DOT-FA79N-6013	
				13. Type of Report and Period Covered 9 FINAL RPT. JAN 1979-JAN 1980	
12. Sponsoring Agency Name and Address U.S. Department of Transportation Federal Aviation Administration National Aviation Facilities Experimental Center Atlantic City, NJ 08405				14. Sponsoring Agency Code ANA-4	
				15. Supplementary Notes	
16. Abstract  This report presents the results of a review of existing <u>Air Traffic Control (ATC)</u> test and support facilities at the <u>National Aviation Facilities Experimental Center (NAFEC)</u> in Atlantic City, NJ, and an analysis assessing the impact of future programs on these facilities and their operations.  The report identifies basic facility enhancements to apply when the facilities are relocated to the new NAFEC Technical and Administrative Complex. The impact of long-term development and operational support programs is described, and requirements for facility development and planning to support these programs are discussed.					
17. Key Words National Aviation Facilities Experimental Center, NAFEC, Air Traffic Control, Test bed facility development, Air Traffic Control test facilities			18. Distribution Statement Document is available to the U.S. public through the National Technical Information Service, Springfield, Virginia 22161		
19. Security Classif. (of this report) Unclassified		20. Security Classif. (of this page) Unclassified		21. No. of Pages	22. Price

## EXECUTIVE SUMMARY

### Project Overview

In January 1979, a review of the existing ATC support facilities at NAFEC was undertaken and an analysis was performed to assess the impact of future programs on NAFEC facilities and operations. The review of existing facilities was conducted to define changes which could improve facility operations upon relocation to the new Technical and Administrative (T&A) Complex during 1980. The assessment of future ATC programs was intended to identify longer term requirements for the development or planning of facility enhancements or new facilities in the T&A complex.

The project was restricted to a review of facilities which support ATC system Research and Development (R&D) and the field system maintenance activities of the operating services (i.e., AAT, AAF).

The review of the existing facilities included observations of the facilities and discussions with FAA NAFEC and user organizations. Information on future programs was derived through reviews of engineering and development program plans and discussions with program managers and system planners.

The NAFEC ATC test and support facilities reviewed were:

- En Route System Support Facility (ESSF)
- Terminal Automation Test Facility (TATF)
- Air Traffic Control Simulation Facility (ATCSF)
- Flight Service Station (FSS) Automation Facilities
- OS Jobshop

In addition, an assessment was made of new support facilities to be installed at NAFEC, including the NAFEC Laboratory Signal Switching System (NLSSS) and the NAFEC Communications Switching System (NCSS).

### Summary of Results

Each ATC facility was evaluated in terms of its capability to support its current mission as well as future R&D programs and operating service requirements. Several areas were identified where basic improvements can be made. The need for advanced planning in several areas to ensure the future development of required capabilities was also identified. Following is a summary of observations, conclusions and recommendations related to current facilities operations and the potential impact of long-term requirements.

## ESSF

The ESSF is a major facility used for NAS En Route test and evaluation and field system support. The ESSF is under configuration management to support its use by the operating services for field hardware and software maintenance. The facility contains an extensive switching capability to allow the various combinations of the 9020A and 9020D computers with display channel equipments which represent the field system equipment configurations (i.e., 9020A/CDC, 9020D/CDC, 9020D/DCC). In addition, special switches were installed to provide interfaces between the Direct Access Radar Channel (DARC) and the 9020A, 9020D, CDC and DCC. Each new development subsystem to be integrated in the ESSF will require special interface provisions to satisfy configuration control requirements. For example, the Electronic Tabular Display Subsystem (ETABS) will be installed with a special "transparent" interface switch. In general, the interface switching requirements have resulted in a high degree of complexity which affects the management and control of the facility and causes errors and loss of productive test time. It is recommended that a centralized switching and control facility be established in the T&A complex to simplify the process of equipment configuration, monitoring and control, and to reduce errors and delays in test support.

Sharing of the ESSF for R&D and field support has not been an effective arrangement in that the operating services require configuration control and can, and often do, exercise priority privileges in the scheduling of the facility. As development activity increases over the next several years, the effect on development projects is likely to become more significant. It is recommended that the problems stemming from sharing a facility for field support and development be major issues in the planning of future facilities at NAFEC (e.g., ATC computer replacement system support facility). The development of independent facilities should be considered whenever possible.

Many of the test activities in the ESSF involve interfaces with other support facilities (e.g., ATCSF, TATF, DABS); each facility collects data for subsequent test analysis. Currently, systems are manually synchronized in time to facilitate data analysis. It is recommended that a master time-synchronization system be developed which can provide automatic synchronization of interfaced systems in order to avoid timing errors inherent in the manual process.

Scheduling of the ESSF is handled by the NAFEC Facility Control Office (FACO) through a manual process of matching user requirements to available hardware configurations. The integration of new systems and a significant increase in development projects in the ESSF will make scheduling a complicated task. It is recommended that automation aids be developed to support facility scheduling.

Users of the ESSF are required to be familiar with many details concerning the operation of the facility. Familiarity with the requirements and procedures is usually acquired through trial-and-error and on-the-job experience. The tasks of user orientation and education will become increasingly important with the growing complexity of the ESSF and the addition of new FAA and contractor users. It is recommended that a formal program for user orientation be developed. In addition, changes in operating procedures in the ESSF should be made to minimize user involvement in basic operations to set up and run the facility.

Terminal Support Facilities

The major terminal ATC support facilities at NAFEC are the TATF and TSSF. The TATF is principally an R&D facility while the TSSF is strictly used by the operating services for field support. The arrangement of separate facilities has precluded, for the most part, the types of problems which exist in sharing the ESSF between the FAA services.

The TATF is not under strict configuration management as is the ESSF and tends to be operated in a more informal manner. The facility experiences some of the same problems as the ESSF. Procedures for equipment set-up and reconfiguration are complex and subject to errors, often resulting in loss of test time. Also, no master time system is available when the TATF is interfaced with external support systems. Voice communications capabilities currently in the TATF are not suitable for good test coordination. Flexibility is limited in the TATF in that the equipment (e.g., PVDs, 9300) from different IOP systems is not easily interchangeable. It is recommended that a capability be developed to facilitate fast interchanging of equipment between the different IOP systems.

Accession For	
NTIS GRA&I	<input checked="" type="checkbox"/>
DDC TAB	<input type="checkbox"/>
Unannounced	<input type="checkbox"/>
Justification	
By _____	
Distribution/	
Availability Codes	
Dist.	Avail and/or special
A	

### ATCSF

The ATCSF will be a primary support facility for many ATC development projects over the next several years. The NAFEC-planned ATCSF enhancement program will provide for considerably improved capabilities. Observations and experience with the ATCSF indicate the need for some basic, near-term enhancements to the facility's capability. It is recommended that improvements be made to the method of preparing surveillance data scenarios. Also, an automated technique should be developed for adapting the ATCSF to any operational site, and a capability should be added to interface the ATCSF with an external master time-synchronization system.

### FSS Automation Facilities

The FSS Automation Facilities will be established on the second floor of the new T&A complex. The facilities will operate independently of other ATC support facilities in the near-term, and will not require significant external support resources. Over the long-term, however, the FSS will need to communicate with the en route system, and appropriate interfaces will need to be developed.

### OS Jobshop

The OS Jobshop supports NAS en route operational software development and maintenance and the software development and data reduction activities of several R&D programs. The kinds of services provided in the Jobshop have remained largely unchanged over the last 4 to 5 years. The facility lacks modern capabilities and job turnaround time is relatively long as compared with advanced computer installations.

The demand for Jobshop services routinely exceeds its capacity. Thus, the Jobshop must be supplemented by the 9020A and E computers in the ESSF. The operating services have priority in using the Jobshop, which occasionally results in delays to development projects.

Activity in the Jobshop is projected to increase significantly over the next several years, and the need to upgrade the facility has been recognized by NAFEC. A plan is in process to procure an IBM 370/168 computer (or equivalent) as a replacement for the current 9020-based Jobshop. The plan also provides for a multi-year development program.

The acquisition process for the new computer system is progressing toward a possible delivery during CY1980; however, unpredictable delays in approval may delay the Jobshop replacement to beyond 1980. It is recommended that contingency plans be developed for supplementing or expanding the current Jobshop capabilities to meet the expected demand.

#### NLSSS

The NLSSS is to be installed in the T&A complex in late 1980. The system will provide an integrated data switching and distribution capability with remote control features. The system will handle the interchange of digital data and analog radar data in the ESSF and TATF. Installation of the NLSSS will offer significant improvements in interface control and switching. It is recommended that the NLSSS control functions be integrated with the centralized switching and control system described earlier.

#### NCSS

The NCSS will replace the Bell 300 Communications System and will provide communications throughout the ATC test and support facilities. The NCSS is scheduled to be operational in the T&A complex in early 1981. An interim capability will be installed initially in the T&A complex. The NCSS will offer modern, computer-controlled communications capabilities. The NCSS is also expected to serve as a basic test bed for development of a new Voice Switching and Control System (VSCS) for field implementation. As such, the NCSS program will generate considerable activity in the ATC laboratories over the period 1981-85.

It is recommended that the control units of the NCSS be located in the centralized switching and control facility recommended for the T&A complex.

#### Impact of Future Programs

Future programs are expected to have a significant impact on NAFEC facility requirements. Many of the programs already in progress, or those scheduled to arrive early in the 1980's, include new hardware systems which are to be interfaced with existing systems. These new systems generally represent engineering models to be tested and used to define field-implementable models. The most significant systems include DABS, ETABS, TIPS, VSCS, AERA and the ATC Computer Replacement. These projects will place heavy demands on NAFEC

support facilities for T&E and software development. In addition, requirements will arise necessitating the development of small-scale laboratories to support man-machine interface development and new device evaluations. A new display laboratory is likely to be required to support the ATC Computer Replacement program.

It is recommended that NAFEC develop detailed long-term technical program plans which include projections of support requirements and activities at NAFEC at least 5 years into the future. These plans should provide the impetus for facility development activities, establish close coordination interfaces with FAA Washington program managers, and define long-term budget and resource requirements.

TABLE OF CONTENTS

	<u>Page</u>
EXECUTIVE SUMMARY	v
1. INTRODUCTION	1-1
1.1 Background	1-1
1.2 Scope	1-2
1.3 Objectives	1-2
1.4 Approach	1-2
2. ATC TEST AND SUPPORT FACILITIES AT NAFEC	2-1
2.1 En Route System Support Facility (ESSF)	2-1
2.1.1 General Description	2-1
2.1.2 ESSF Interfaces	2-4
2.1.2.1 9020/Display Channel Interfaces	2-4
2.1.2.2 9020/DARC Interface	2-4
2.1.2.3 Coded Time Source	2-8
2.1.2.4 Surveillance Interfaces	2-8
2.1.2.5 DABS Front End Processor	2-8
2.1.3 Planned Systems and Interfaces in the ESSF	2-9
2.1.3.1 NAFEC Laboratory Signal Switching System	2-9
2.1.3.2 ETABS Interface	2-9
2.1.3.3 ATC Computer Replacement	2-9
2.1.3.4 Interface Processor	2-12
2.1.3.5 Automated En Route ATC (AERA)	2-12
2.1.4 ESSF Activities	2-14
2.1.5 Test Conduct in the ESSF	2-14
2.1.5.1 Levels of Test Activities	2-14
2.1.5.2 Data for ATC Testing in the ESSF	2-15
2.1.5.3 Observations of ESSF Operations	2-17
2.1.6 ATC Facility Simulations: Adaptation	2-19
2.1.7 Facility Scheduling at NAFEC	2-21
2.1.7.1 Current Scheduling Practices	2-21
2.1.7.2 Scheduling Observations	2-23
2.1.8 ESSF Enhancement Considerations	2-24
2.1.8.1 System Interface Requirements	2-24
2.1.8.2 Centralized Facility Switching Control	2-24
2.1.8.3 Multi-System Synchronization Requirements	2-25
2.1.8.4 Facility User Orientation	2-26
2.1.8.5 Scheduling Requirements	2-27
2.1.8.6 Facility Considerations for ETABS Control Sectors Installation	2-29

TABLE OF CONTENTS (Continued)

	<u>Page</u>
2.2 Terminal Automation Test Facility (TATF)	2-30
2.2.1 Current TATF Operations	2-30
2.2.2 Future System Installations in the TATF	2-31
2.2.2.1 Terminal Information Processing System (TIPS)	2-31
2.2.2.2 ATC Computer Replacement Program	2-31
2.2.2.3 Tower Cab Systems	2-31
2.2.3 A Suggested Enhancement to the TATF Test Bed Capability	2-33
2.2.3.1 Long-Term Need for Flexibility	2-33
2.2.3.2 A Suggested TATF Switching Capability	2-34
2.2.4 Multi-Facility Testing Considerations	2-34
2.2.4.1 Establishment of Multi-System Configurations	2-34
2.2.4.2 Use of Voice Communications in the TATF	2-36
2.2.4.3 Time Synchronization	2-36
2.2.5 TATF Support to Field Operations	2-36
2.3 Flight Service Station Facilities Automation Program	2-37
2.3.1 NAFEC FSS Installations	2-37
2.3.2 The Impact of the FSS Laboratory on the ATC Test Bed	2-37
2.4 Air Traffic Control Simulation Facility	2-40
2.4.1 Long-Term Considerations for the ATCSF	2-42
2.5 NAS Jobshop Facility	2-44
2.5.1 General	2-44
2.5.2 Operations	2-44
2.5.2.1 Process Control	2-44
2.5.2.2 Work Shifts	2-46
2.5.2.3 Accounting	2-46
2.5.2.4 Users	2-47
2.5.2.5 Turnaround Time	2-47
2.5.2.6 9020 Jobshop Upgrading Efforts	2-47
2.5.3 Future Jobshop Planning	2-48
2.5.3.1 NAFEC Plan for Jobshop Replacement	2-48
2.5.3.2 Contingency Planning	2-49
2.5.3.2.1 Contingency Planning for Moderate Delay in Upgrading	2-49
2.5.3.2.2 Contingency Planning for Long Delay in Upgrading	2-52

TABLE OF CONTENTS (Continued)

	<u>Page</u>
2.5.4 Additional Considerations for Future Jobshop Planning	2-52
2.5.4.1 Upgrading of Current Jobshop	2-53
2.5.4.2 The Honeywell 66/60 System	2-53
2.5.4.3 Impact of the 9020 Replacement Program	2-54
2.5.4.4 Software Test Tools	2-54
2.6 NAFEC Communication Switching System	2-55
2.6.1 The Impact of NCSS on the ATC Test Bed	2-55
2.6.2 NCSS/NLSSS Coordination	2-57
2.7 NAFEC Laboratory Signal Switching System	2-57
2.7.1 The Impact of the NLSSS on the ATC Test Bed	2-59
3. CURRENT USERS OF NAFEC ATC FACILITIES	3-1
4. FUTURE ATC PROGRAMS AT NAFEC (1980-1989)	4-1
4.1 Description of Major Future Programs	4-3
4.1.1 Discrete Address Beacon System (DABS)	4-3
4.1.2 Electronic Tabular Display Subsystem (ETABS)	4-4
4.1.3 Terminal Information Processing System (TIPS)	4-5
4.1.4 Automated Flight Service Station (AFSS)	4-5
4.1.5 Voice Switching and Control System (VSCS)	4-5
4.1.6 Control Sector Redesign	4-6
4.1.7 Automated En Route Air Traffic Control (AERA)	4-7
4.1.8 ATC Computer Replacement	4-10
4.2 Impact of Future Programs on NAFEC	4-10
4.3 Need for Long-Term Technical Planning	4-12
4.4 Need for Advanced Technology Programs	4-12
5. CONCLUSIONS AND RECOMMENDATIONS	5-1
5.1 Laboratory Control and Management	5-1
5.1.1 Interface Switching and Control	5-1
5.1.2 Interfacility Time-Synchronization	5-1
5.1.3 Facility Scheduling	5-2
5.1.4 Facility User Orientation	5-2
5.2 Software Support Capabilities	5-3
5.2.1 NAS Jobshop Capacity and Capability	5-3
5.2.2 NAS Jobshop Development Plans	5-3
5.2.3 Coordination of Software Test Tool Development	5-4

TABLE OF CONTENTS (Continued)

	<u>Page</u>
5.3 ATC Simulation Support Capabilities	5-4
5.3.1 ATCSF Support	5-4
5.3.2 Site Simulation in the ESSF	5-5
5.4 Long-Term Facility Development	5-5
5.4.1 General Planning	5-5
5.4.2 Shared Usage of Facilities for E&D and Operational Support	5-6
5.4.3 Small-Scale Support Facilities	5-6
APPENDIX A: ESSF SYSTEMS AND EQUIPMENT	A-1
APPENDIX B: TATF SYSTEMS AND EQUIPMENT	B-1
APPENDIX C: SYSTEMS TO BE INTEGRATED WITH THE ESSF AND TATF	C-1
APPENDIX D: A SUGGESTED CONCEPT FOR TIME SIGNAL DISTRIBUTION TO NAFEC ATC LABORATORIES	D-1
APPENDIX E: A PROPOSAL FOR A NAFEC ATC LABORATORIES AUTOMATED USER BRIEFING CENTER	E-1
APPENDIX F: FLIGHT SERVICE STATION FACILITIES AUTOMATION PROGRAM	F-1
APPENDIX G: REFERENCES	G-1
APPENDIX H: LIST OF ABBREVIATIONS	H-1

## LIST OF ILLUSTRATIONS

	<u>Page</u>	
FIGURE 2-1	BASIC ESSF INTERFACE SWITCHING	2-3
FIGURE 2-2	EN ROUTE SYSTEM INTERFACES WITH EXTERNAL DEVICES	2-5
FIGURE 2-3	OVERVIEW OF ESSF INTERFACES	2-6
FIGURE 2-4	INPUT/OUTPUTS TO DARC SWITCH IN ESSF	2-7
FIGURE 2-5	ESSF WITH NLSSS INCLUDED	2-10
FIGURE 2-6	ESSF WITH ETABS INCLUDED	2-11
FIGURE 2-7	ESSF WITH ATC COMPUTER REPLACEMENT SYSTEM AND WITH INTERFACE PROCESSOR	2-13
FIGURE 2-8	OVERVIEW OF ESSF SYSTEM TEST PROCESS	2-16
FIGURE 2-9	UDS LOW ALTITUDE SECTOR BOUNDARIES	2-20
FIGURE 2-10	SAMPLE ESSF COMPUTER SCHEDULE	2-22
FIGURE 2-11	NAFEC TIPS PATCH PANEL CAPABILITY	2-32
FIGURE 2-12	PROPOSED TATF SYSTEM CONFIGURATIONS	2-35
FIGURE 2-13	MODEL 1 AFSS SYSTEM CONFIGURATION	2-38
FIGURE 2-14	MODEL 2 AFSS SYSTEM CONFIGURATION	2-39
FIGURE 2-15	FORMS FOR OS AND NOSS PROCESSING REQUESTS	2-45
FIGURE 2-16	NLSSS OPERATIONAL ENVIRONMENT	2-58
FIGURE 4-1	MAJOR PROGRAMS IMPACTING NAFEC TESTING & EVALUATION FACILITIES	4-2
FIGURE 4-2	AERA TEST BED	4-8
FIGURE 4-3	DISPLAY AND DATA ENTRY EQUIPMENT FOR AERA DEVELOPMENT AND HUMAN FACTORS EXPERIMENTATION	4-9
FIGURE A-1	NAFEC BUILDING #149: FIRST FLOOR EQUIPMENT LOCATIONS	A-2
FIGURE A-2	NAFEC BUILDING #149: SECOND FLOOR EQUIPMENT LOCATIONS	A-3
FIGURE A-3	NAS EN ROUTE LABORATORY	A-4
FIGURE A-4	ESSF DIGITAL SURVEILLANCE DATA PATCHING	A-5
FIGURE A-5	CTS SUBSYSTEM INTERCONNECTIONS	A-6
FIGURE A-6	CTS UNIT BLOCK DIAGRAM	A-7
FIGURE A-7	JOBSHOP ROOM LAYOUT	A-9

LIST OF ILLUSTRATIONS (Continued)

		<u>Page</u>
FIGURE B-1	TATF SYSTEMS OVERVIEW	B-2
FIGURE B-2	BASIC ARTS III SYSTEM	B-5
FIGURE C-1	ETABS SYSTEM CONFIGURATION	C-2
FIGURE C-2	DARC SYSTEM CONFIGURATION	C-3
FIGURE C-3	TIPS INFORMATION FLOW	C-4
FIGURE C-4	TOWER DISPLAY SUBSYSTEM (A SUBSET OF TIPS)	C-5
FIGURE D-1	A SUGGESTED TECHNIQUE FOR A NAFEC PROBLEM TIME SIGNAL GENERATOR	D-2
FIGURE F-1	SIMPLIFIED OVERVIEW OF AFSS ENVIRONMENT	F-2
TABLE 2-1	ATCSF PLANNED CAPABILITY	2-41
TABLE 2-2	NCSS EQUIPMENT	2-56
TABLE A-1	NAS JOBSHOP COMPUTER SUBSYSTEM	A-10
TABLE B-1	TATF SYSTEMS I/O CHANNEL ASSIGNMENTS	B-3
TABLE E-1	USER BRIEFING CENTER: TOPICS	E-2

## 1. INTRODUCTION

### 1.1 Background

A new Technical and Administrative (T&A) Complex is currently under construction at the National Aviation Facilities Experimental Center (NAFEC). The complex will house most of the personnel working at NAFEC and many of the Air Traffic Control (ATC) laboratory and support facilities currently located in several buildings on the center. In addition, new systems to support ATC R&D projects and to enhance testing and software development capabilities are being planned for installation in the new building.

The basic NAFEC facilities were initially established as test beds for engineering development and operational testing of ATC automation functions. The en route and terminal ATC laboratory and support facilities at NAFEC have evolved over the years as the ATC systems have progressed through the phases of development and testing to field implementation. Major new development programs associated with the future ATC systems will have significant new requirements for development and testing and more flexibility and efficiency in the operation and control of the facilities will be necessary.

The NAFEC building program offers an opportunity to review the ATC test and support facilities and plan for an upgrading of the existing facilities and the installation and integration of the new facilities.

In January 1979, MITRE was tasked by the Engineering Management Staff at NAFEC to conduct a review of the existing facilities and consider the enhancement needs in view of future R&D and field support programs.

This document describes the MITRE review and identifies areas in which the NAFEC facilities and capabilities should be enhanced and where planning is needed to anticipate the work that must be accomplished to support future programs.

Many of the recommendations in this report hinge on assumptions concerning the requirements of future ATC automation development programs, the ongoing role of NAFEC as an R&D test center and field support facility, and schedules for the longer term programs which are not yet solidified. Generally, the time frame for which the recommendations in this report apply is 1980-1989.

## 1.2 Scope

The scope of this study was restricted to a consideration of capabilities and facilities required to support ATC automation research and development (R&D), and the field hardware and software maintenance activities of the FAA operating services (AAT, AAF). Specifically, En Route, Terminal and Flight Service Station (FSS) automation programs were reviewed. The principal reference for future development programs was FAA-EM-78-16, "Definition, Description and Interfaces of the FAA's Development Programs". Though the study was generally directed at technical considerations, procedures and organizational factors involved in the operations of the NAFEC facilities were assessed to some degree.

## 1.3 Objectives

The specific objectives of this study were to:

- a. Identify methods and capabilities to generally provide enhanced ATC Test and Evaluation (T&E) services and facilities in the new NAFEC Technical and Administrative Complex.
- b. Identify long-term T&E, software production and maintenance facility requirements to support on-going R&D activities and those of the operating services.
- c. Identify requirements for planning to develop new facilities and capabilities needed to support long-term programs.

## 1.4 Approach

The NAFEC facility study involved several activities to collect basic information, identify areas for improvement and define requirements and viable alternatives for facility development.

The initial phase of work included a collection of pertinent information concerning the basic details and status of the FAA building program, details of current laboratory facilities and their operation, FAA planned enhancements to the NAFEC facilities, and the general roles and responsibilities of the facility user organizations.

Early in the study several meetings were held with NAFEC building planning people and briefings were received from various FAA project personnel involved in active ATC projects at NAFEC.

The initial data collection work served as a foundation for the study. The work identified basic areas for potential improvement in existing facilities and operations, and explored areas already in the process of development.

Associated with the data collection effort was a review of advanced technology areas for potential application in the NAFEC laboratories. A visit was made to the NASA Johnson Space Flight Center to investigate the operations of the large-scale computer and simulation facilities at the Center. Discussions were held with NASA personnel and tours were taken of the facilities. Facility control and configuration problems analogous to NAFEC's were identified and the NASA approaches to solving these problems were reviewed.

A trip was taken to The MITRE Corporation, Bedford, Massachusetts office to discuss fiber optics technology and projects involving applications of the technology. Several potential applications of fiber optics at NAFEC were discussed. A trip was also taken to the Sanders Corporation in Nashua, New Hampshire where development work and support requirements for the ETABS equipment were observed and discussed.

A major phase of work during the study involved a review to determine the specific test and support requirements of the NAFEC facility user organizations including anticipation of their future requirements. A comprehensive list of R&D programs in various stages of progress and planning was developed. In the case of many of the nearer term programs it was possible to compile details concerning each program's schedules, ATC system interfaces and configuration details, test objectives, and test and analysis requirements by reviewing program plans and interviewing program managers. For longer term programs it was necessary to make basic assumptions as to schedules and test requirements. The best available information on longer term programs was accumulated through discussions with FAA program planners and groups involved in future ATC system development. Much of the information was derived from FAA report FAA-EM-78-16.

The information on the R&D programs was reviewed to identify program schedule overlaps, common requirements for test and support facility usage, and requirements for special interfaces, software development and simulation support.

The near and long-term requirements of the operating services to maintain system software and hardware were investigated through discussions with Air Traffic Service and Airway Facilities Service personnel. Information was collected on the operating services utilization of NAFEC facilities, their problems with the facilities, their in-house projects to enhance their capabilities and their views on long-term requirements and necessary capabilities to support their work.

The final phase of the study involved an analysis to assess the near and long-term requirements of the user organizations in light of the current capabilities at NAFEC. The analysis resulted in the list of conclusions and recommendations in this report concerning the state of NAFEC facilities and necessary plans to improve or enhance the facilities.

## 2. ATC TEST AND SUPPORT FACILITIES AT NAFEC

The following sections describe the primary ATC test and support facilities which are to be installed in the new T&A Complex at NAFEC. The facilities are described in terms of their configuration characteristics and functional role in supporting ATC system development and field operations. Information concerning new systems to be added in the near-term is also presented. Each facility is reviewed in terms of its capability to support its current basic mission and capability to support future R&D and operating service requirements. Areas are discussed where basic improvements and long-term planning are needed to ensure that future requirements are adequately met.

### 2.1 En Route System Support Facility (ESSF)

The ESSF systems and capabilities are described herein. Current configurations and the expected configurations resulting from the integration of new development systems are discussed and observations concerning configuration complexity, facility control and user interaction are presented. Several areas are addressed where improvements and enhancements are needed.

Appendix A contains diagrams of the ESSF systems, floor plans and equipment. Appendix C contains simplified block diagrams of ESSF systems to be installed in addition to the current systems.

#### 2.1.1 General Description

The NAS 9020 systems, Display Channels, communications equipment, instrumentation and interface facilities which exist in building #149 at NAFEC are collectively called the En Route System Support Facility. Figures A-1 and A-2 contain diagrams of the equipment layout.

The ESSF includes computer systems and displays to simulate an En Route Air Traffic Control Center (ARTCC). In any ARTCC, either a 9020A or a 9020D system serves as the Central Computer Complex. The 9020A operates with the Computer Display Channel (CDC) to provide ATC displays; the 9020D operates with either the CDC or the Display Channel Complex (DCC). The DCC, referred to as the 9020E, can control a larger number of ATC display positions than the CDC.

The ESSF includes a 9020A, 9020D, CDC and 9020E. To satisfy all test configuration requirements without the expense of three complete ARTCC systems, NAFEC has installed special switching hardware which allows the system interfaces to be established as required. Figure 2-1 illustrates the basic switching capabilities to interface the 9020s and the display channels.

Facilities external to the ESSF supply surveillance data inputs for testing. For example, the Air Traffic Control Simulation Facility (ATCSF), currently in Building #19 at NAFEC, may be scheduled to supply simulated surveillance data. The air traffic, which the surveillance data represent, may be dynamically controlled by operators in the ATCSF to provide for realistic operational testing.

Surveillance inputs are also available from several remote radar sites. Digital tape recorders are available for recording and playback of surveillance data from remote sites.

In addition to simulating NAS en route processing, the 9020's are used on a part-time basis for NAS off-line support operations (see Section 2.5.1).

As indicated in Figures A-1, A-2 and A-3, other systems are installed in the ESSF in addition to the NAS en route computers, including:

- . Discrete Address Beacon System Front End Processor (DABS FEP) - A Texas Instruments 900 series computer which processes data on the DABS data link communications channel.
- . TESDATA MS68 - A hardware monitor, with probe connections to selected points in the 9020A and D systems.
- . "E" Position Consoles - A number of consoles which interface to National Weather Service facilities, including the Geodetic Orbiting Earth Satellite (GOES), for development of weather processing and weather data distribution systems. A NAS Plan View Display (PVD) is currently included in the console equipment complement.
- . DARC system - Direct Access Radar Channel, with a 9020 system interface switch.
- . Jobshop - Used for processing a variety of off-line jobs, e.g., system builds and data reductions. The jobshop is discussed in Section 2.5.

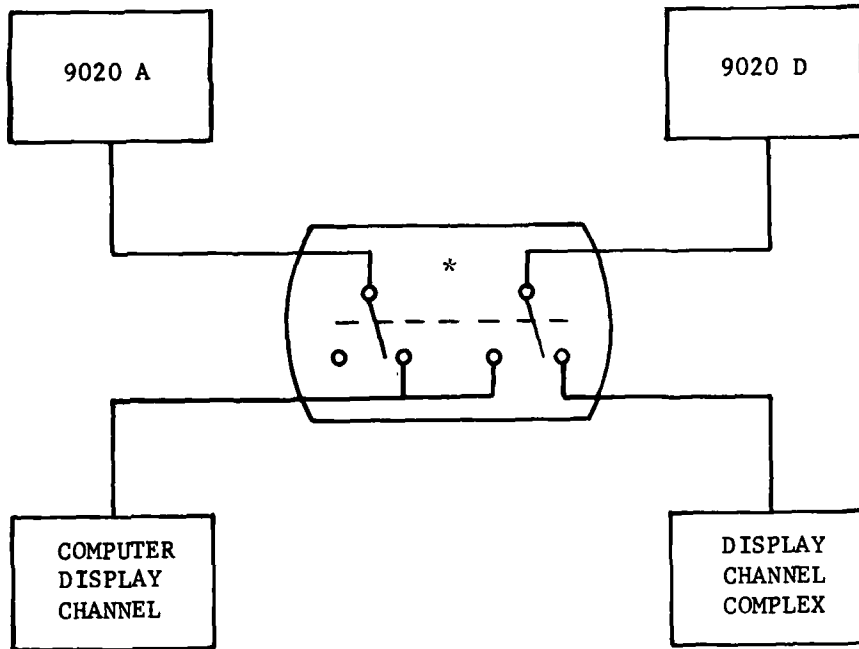

\* SWITCHING FUNCTION IS ACCOMPLISHED WITH MULTIPLE HARDWARE UNITS.

FIGURE 2-1 BASIC ESSF INTERFACE SWITCHING

## 2.1.2 ESSF Interfaces

### 2.1.2.1 9020/Display Channel Interfaces

Figure 2-2 illustrates the interface of the 9020 with external devices. The Peripheral Adapter Module (PAM) serves as a junction for the devices which are external to the Central Computer Complex (CCC). Each of the three available PAM's is capable of providing up to 159 adapter channels. There are eight adapter types, each designed to fulfill a system need. These are:

- . INTO/INTI - Interfacility input/output. At NAFEC, the ESSF to TATF interface normally uses these adapters.
- . GPO/GPI - General purpose input/output. Interface to the Non-Radar Keyboard Multiplexor to the D and A controller positions.
- . TTY, FDEP, 1052 - Interface to teletype, flight data entry positions, and supervisory typewriters.
- . Common Digitizer - Accepts surveillance data from external surveillance facilities via the Data Receiver Equipment (DRE).

The display channel, which processes data for the R-Controller displays, interfaces with the 9020 via Selector Channels in the IOCEs.

Figure 2-3 contains a simplified diagram of the current switching of system interfaces in the ESSF. Switches manufactured by IBM were installed to provide the alternative configurations of the 9020s and Display Channels.

### 2.1.2.2 9020/DARC Interface

Figure C-2 contains a DARC system block diagram. A special hardware switch (Figure 2-4) manufactured by T-BAR Incorporated was installed to switch the DARC to either the 9020A or D system, the Display Channel or the DRE. The DARC switch handles the following three types of signals:

- . Surveillance data inputs from the DRE;
- . Flight data updates from the 9020A or D via the GPO adapter;
- . DARC output data to the Display Generator units in either the CDC or DCC systems.

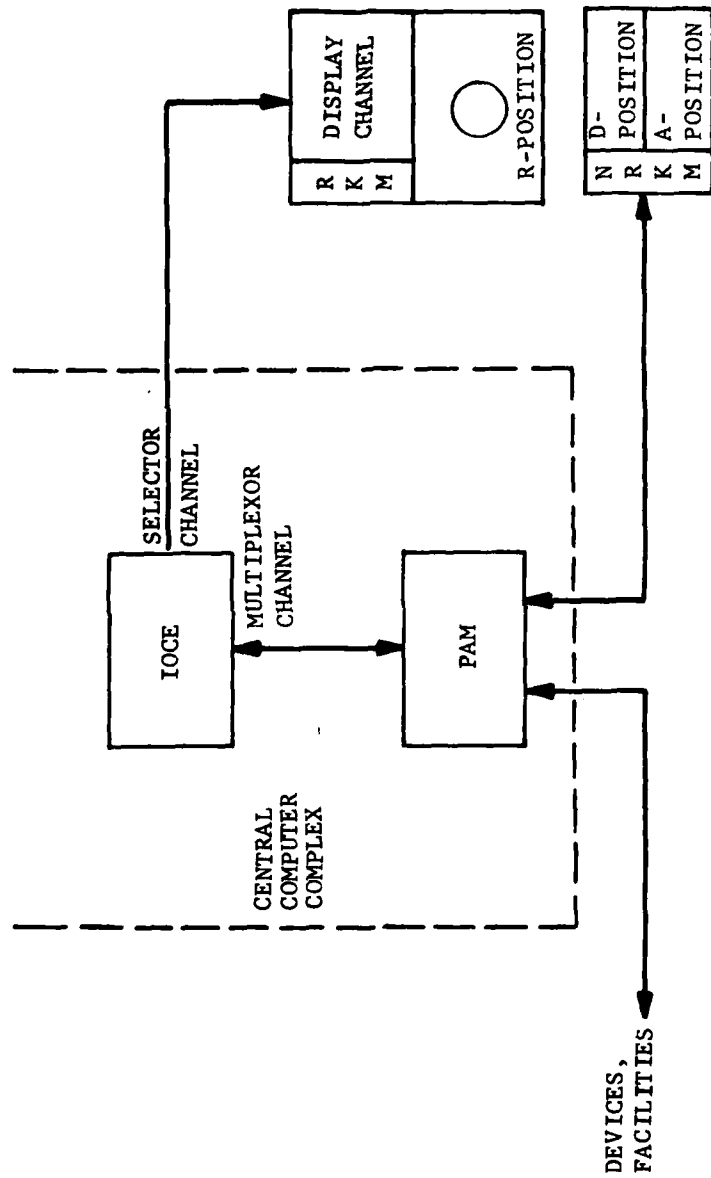

FIGURE 2-2 EN ROUTE SYSTEM INTERFACES WITH EXTERNAL DEVICES

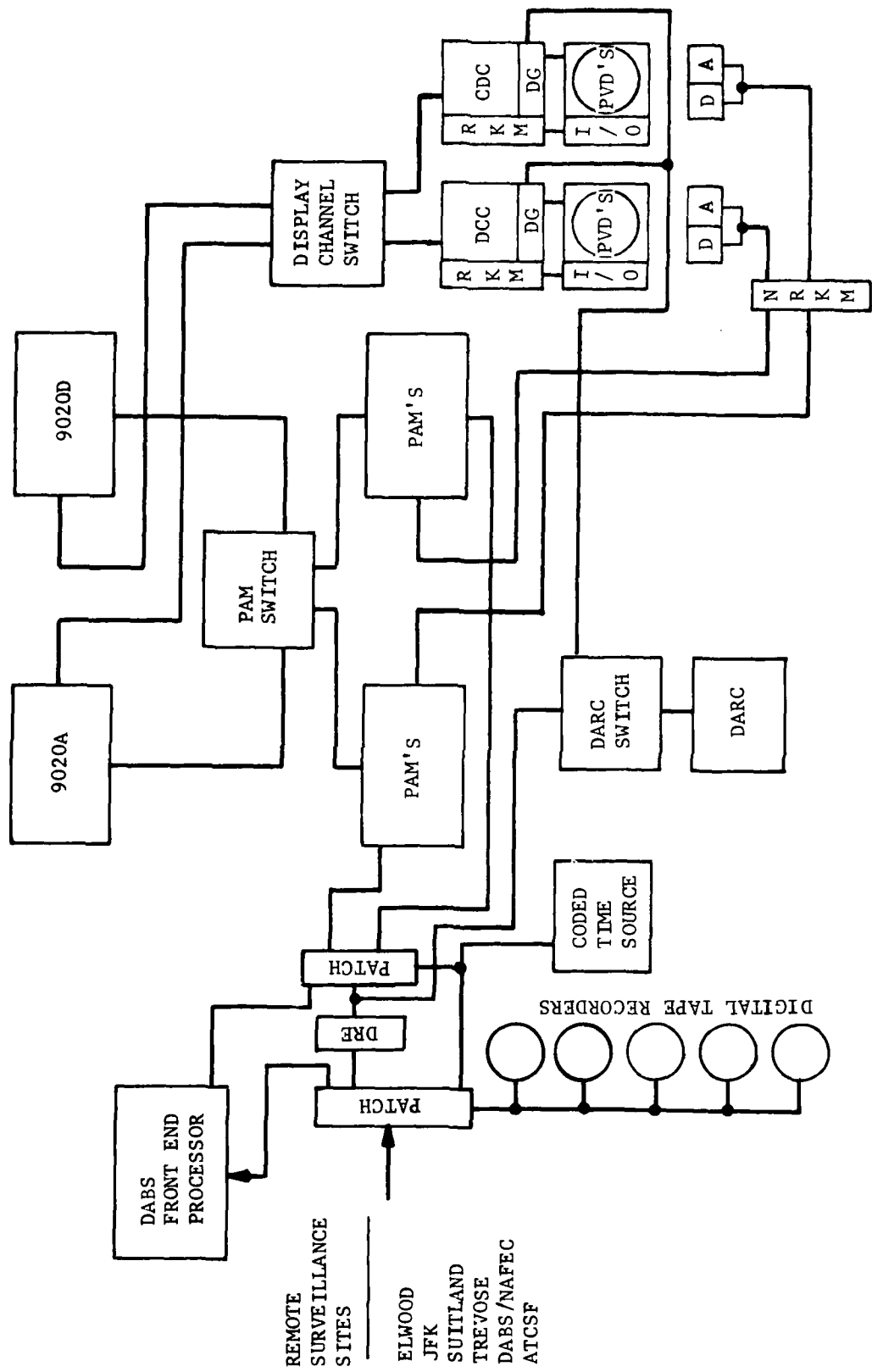
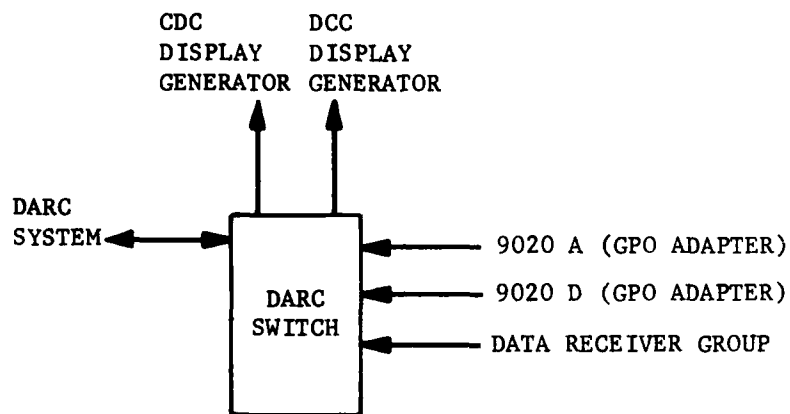

FIGURE 2-3 OVERVIEW OF ESSF INTERFACES



- 1) MANUFACTURED FOR USE AT NAFEC BY "T-BAR"
- 2) 19" RACK WHICH INCLUDES ONLY RELAY SWITCHING
- 3) HANDLES SIGNALS IN THE RADIO FREQUENCY RANGE (GREATER THAN 1 MHz)

FIGURE 2-4 INPUT/OUTPUTS TO DARC SWITCH IN ESSF

### 2.1.2.3 Coded Time Source

The Coded Time Source (CTS) provides bit parallel, byte serial time-of-day messages for the Central Computer Complex upon request. The CTS is initially synchronized to WWV via a receiver in the CTS cabinet. Supplemental outputs from the CTS are:

- . Wickes Synch Pulse - pulse for synchronization of Wickes Clocks;
- . Time-of-Day in serial code for data collection tape recordings;
- . Time-of-Day in serial code modulated for teletype line transmission;
- . Time-of-Day in binary coded decimal format which can be used for data printouts and the monitor in the Data Receiver Equipment.

Figures A-5 and A-6 contain block diagrams indicating the CTS functional units and equipment interconnections. There are two CTS systems in the ESSF; each system contains two complete CTS units.

### 2.1.2.4 Surveillance Interfaces

The surveillance patch panel (Figure A-4) handles the interface between the PAM Common Digitizer (CD) adapters and surveillance sensors, digital tape recorders and the CTS. The tape recorders (two Amplex DR1800's, two Sangamo Sabre IV's, one Bell and Howell VF3700) record digital data which is received from external sites (i.e., DABS sensors, ASRs, ARSRs, or the ATCSF) and can playback the data into the PAM's. The CTS provides time-of-day data on the recordings.

### 2.1.2.5 DABS Front End Processor

The DABS Front End Processor (FEP) interfaces the DABS Communications Channel (handling data-link functions) to the 9020 system via the GPO/GPI adapters. The FEP, a Texas Instruments minicomputer-based device, performs format translations as well as communications system verification.

### 2.1.3 Planned Systems and Interfaces in the ESSF

Information gathered from FAA planning documents and from personal interviews of project personnel indicates that a number of new systems will be installed in the ESSF in addition to the currently existing systems. The paragraphs below discuss each planned system and evaluate the interface requirements.

#### 2.1.3.1 NAFEC Laboratory Signal Switching System

The NLSSS (Reference 2), a software-controlled switching and distribution system, will interface data communications between the ESSF, TATF, TSSF and remote radar sites. The NLSSS will handle demodulated digital data (as well as analog data) at bit rates up to 9600 baud. At this time, the intended use of the NLSSS does not appear to include data channels which consist of parallel data lines (e.g., GPO/GPI adapters). However, the expansion capability in the NLSSS design may provide for such capabilities in the future.

The digital tape recorders and the serial CTS signal will also be interfaced with the NLSSS. All surveillance data will be input to the ESSF via the NLSSS. The DABS FEP will interface with the NLSSS for communications with the external sites.

#### 2.1.3.2 ETABS Interface

The ETABS engineering model is expected to be installed in the NAFEC ESSF in mid-1980. ETABS will interface with the en route system at the IOCE Selector Channels. As illustrated in Figure 2-6, ETABS will involve the installation of new control sector devices (currently six sector configurations are planned) in the ATC laboratory, two interface processors with peripherals, and a hardware switch to switch ETABS into and out of the 9020 interface. Figure C-1 contains a system block diagram of ETABS.

#### 2.1.3.3 ATC Computer Replacement

An FAA program to procure a replacement for the present ATC computer system is currently in an early stage of development. It is likely that an engineering model of the replacement will be installed at NAFEC in the 1985-1990 timeframe. Several design concepts for the replacement system are currently being evaluated by the FAA. The installation in the ESSF could result in one of the following situations:

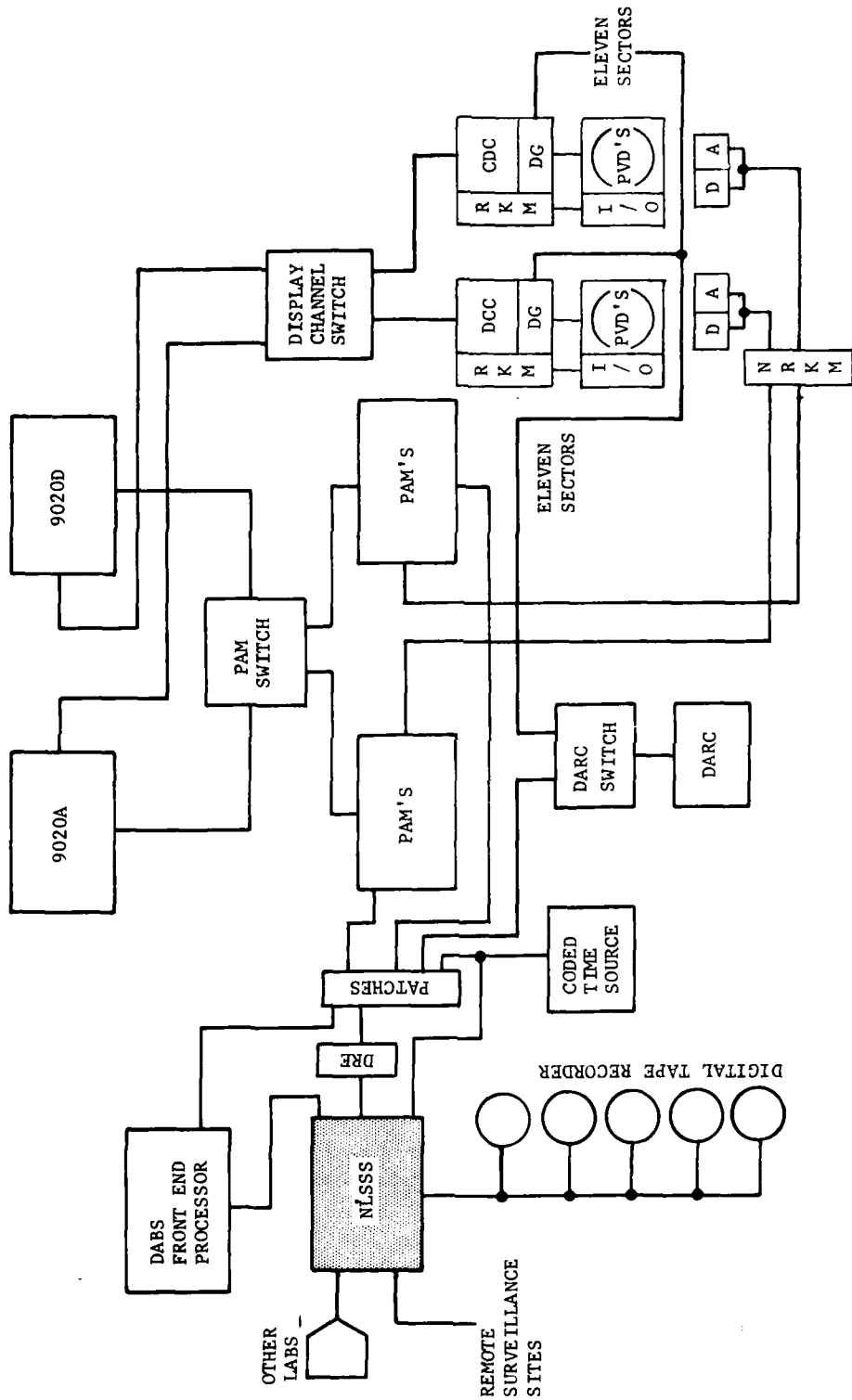

FIGURE 2-5 ESSF WITH NLSS INCLUDED

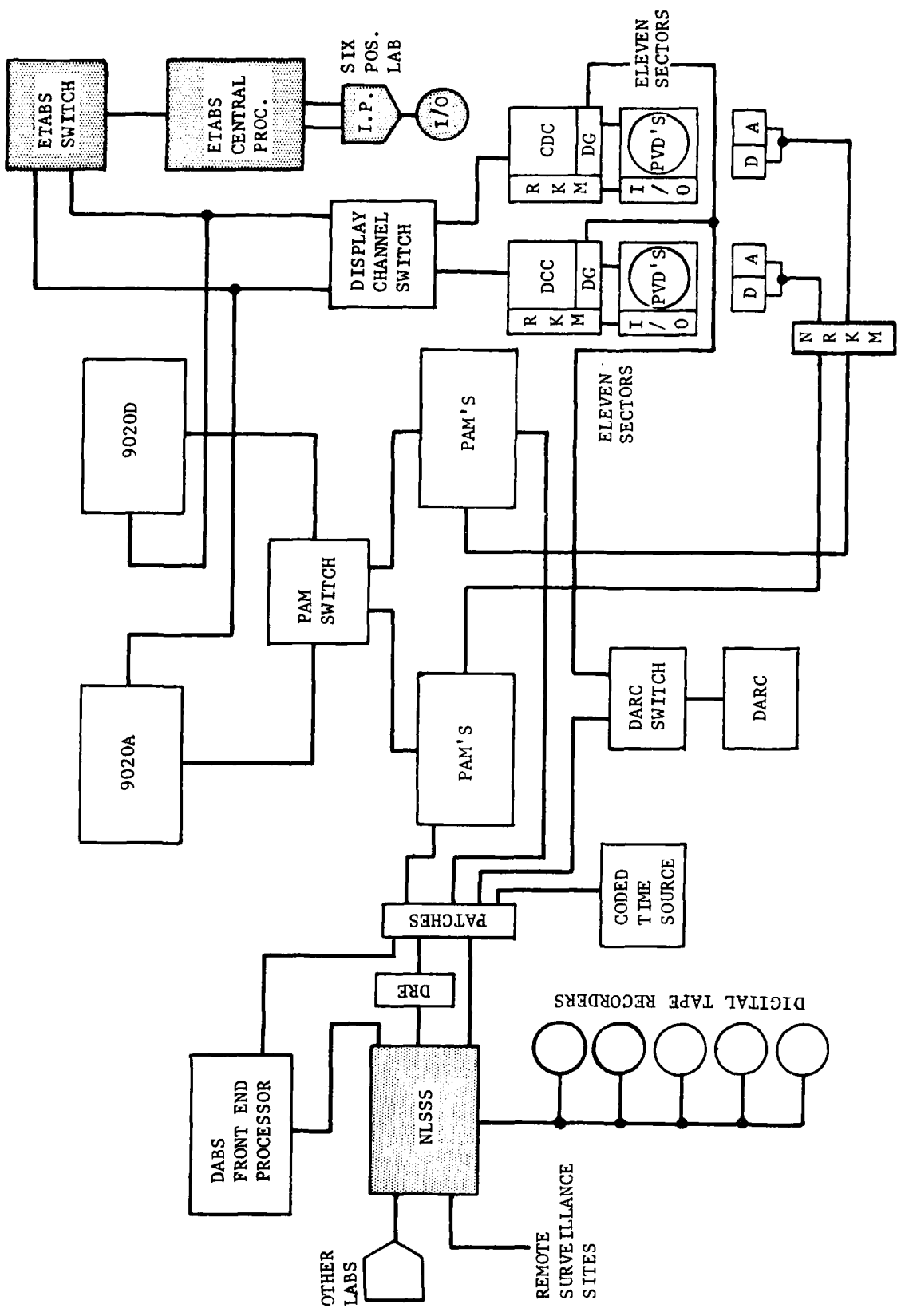

FIGURE 2-6 ESSF WITH ETABS INCLUDED

- . ATC Computer Replacement includes a CPU with Display Channel. Field support with the 9020 systems would continue. ATC Computer Replacement development would require interfaces with DABS, ETABS, and DARC systems, since these would already be field installed. Interfaces between the smaller systems would need to be switchable while maintaining strict configuration control with the 9020 interface.
- . ATC Computer Replacement System is a distributed processor architecture and utilizes ETABS, DARC and additional processor(s). ETABS and DARC would continue to be required for 9020 interfacing for field support while being switchable to the ATC Computer Replacement configuration for E&D.
- . Only an ATC Replacement Computer central processor is installed. In this case a switchable interface with the current display channel (DDC or CDC) would be required to support initial E&D.
- . ATC Replacement Computer procurement includes a replacement for the display channel, and the display channel is delivered before the central computer. In this case, either a 9020 interface or emulator would be required for E&D testing.

Figure 2-7 indicates with dashed lines the interfaces which may be required as the ATC Computer Replacement is installed.

#### 2.1.3.4 Interface Processor

At this time, an effort is under way to evaluate the feasibility of a device to replace or to supplement the Peripheral Adapter Module (PAM). The device is called the Interface Processor (IP). The IP is indicated in Figure 2-7. Dashed lines indicate the interfaces for the IP which may be required.

#### 2.1.3.5 Automated En Route ATC (AERA)

Since 1974, the FAA's Office of System Engineering Management (OSEM) has sponsored an R&D project to increase the use of automation in the ATC system. The AERA system will utilize the DABS air-ground data-link, a Voice Recognition System and an advanced control sector design. An AERA interface with the 9020 will be required during the test and evaluation phase.

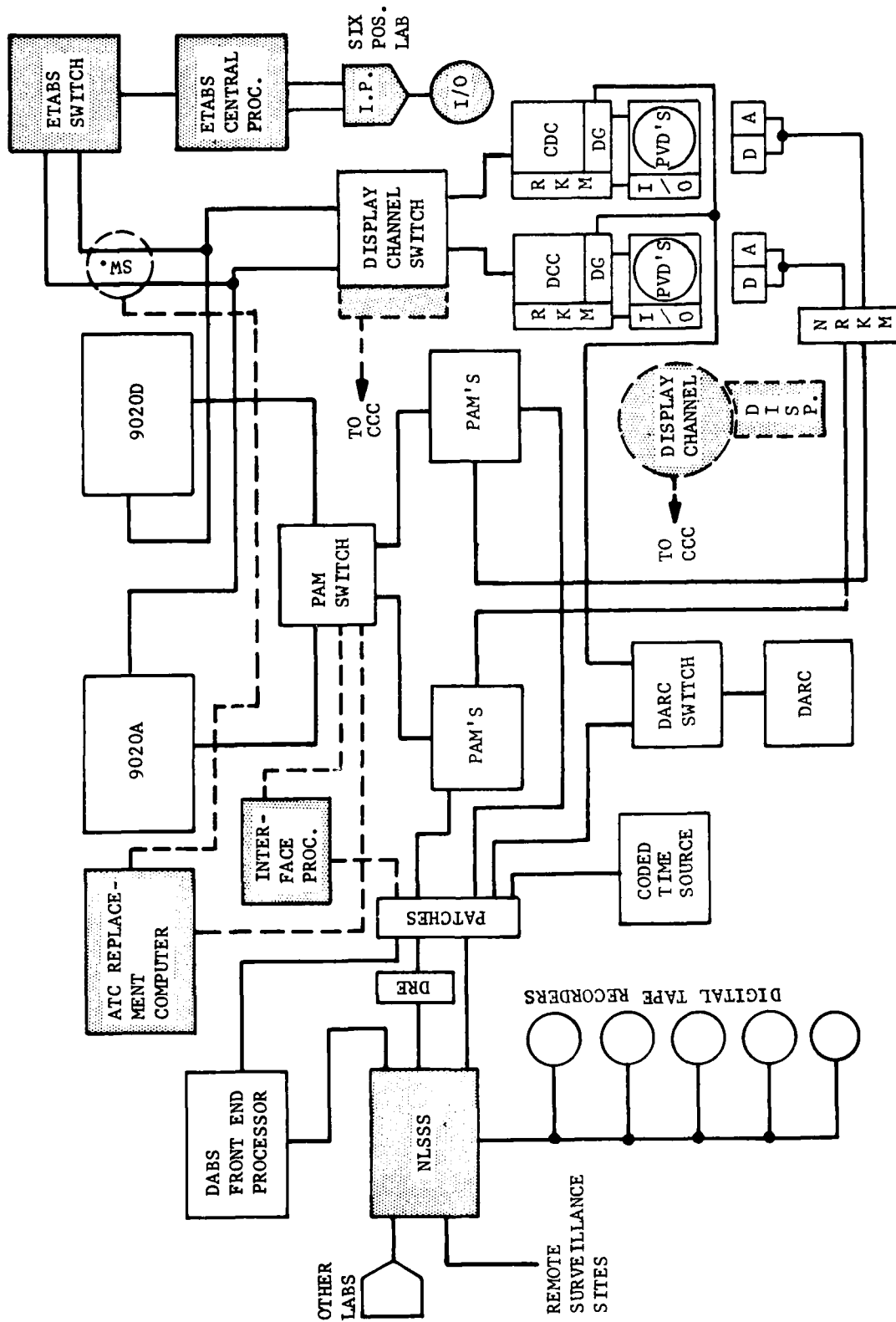

FIGURE 2-7 ESSF WITH ATC COMPUTER REPLACEMENT SYSTEM AND WITH INTERFACE PROCESSOR

#### 2.1.4 ESSF Activities

The three major activities supported by the ESSF may be categorized as follows:

- . Operational ATC simulations - Test configuration usually includes a 9020 system operating with a display channel, a source of surveillance data, operators and system support personnel, to simulate En Route ATC operations.

The operational system can be exercised in this mode to analyze system functions for operational impact, for verification that a functional design is operationally viable, and for system-level testing of program code prior to implementation in the field.

- . Hands-on off-line support - Usually involves the execution of off-line jobs on the 9020 operating as a single central processor (i.e., simplex).
- . Remote off-line support - Involves jobs submitted by the facility users to be executed in batch mode under the IBM Operating System and the NAS Operational Support System (NOSS).

The above activities are necessary to support two major ESSF services:

- . Research and Development - the current system is changed to experiment with new concepts or capabilities;
- . Field Support - problem/trouble reports from the field are investigated and fixed; NAS Change Proposals are evaluated, and new versions of system builds are generated and tested prior to shipment to the field facilities.

#### 2.1.5 Test Conduct in the ESSF

##### 2.1.5.1 Levels of Test Activities

A general classification of test activities in the ESSF is as follows:

- . Full System Testing - The complete system with controllers and simulated aircraft is operated to investigate ATC operational requirements for an automation system or technique. In the recent past (1975-1979) this kind of testing has occurred infrequently. In the future, the need to integrate ETABS, DABS with Data Link, ATARS, Conflict Alert and DARC will probably require an increase in full system operational testing at NAFEC.

- . Intermediate System Testing - An ATC simulation is operated with only a subset of functions under test. An example is the En Route Minimum Safe Altitude Warning (E-MSAW) system testing which required flight data, simulated radar data and two console operators. The limited simulation was necessary to examine ATC situations for which E-MSAW was designed.
- . Software Development - Facility time is scheduled to build and test software. Unit and string testing is performed. Subsequently, display laboratory is scheduled to execute a demonstration of a full operational system.
- . Special Hardware for Man/Machine Interface - Operator-used equipment can be modified for special evaluations of the displayed information, keyboard entry formats, or other changes to input or output devices. These changes remain for required time intervals and must be tolerated by other scheduled system users.
- . Maintenance Testing - Special software and periodic tests are scheduled to maintain the system operability.

#### 2.1.5.2 Data for ATC Testing in the ESSF

To successfully conduct a system test in the ESSF, a number of activities are required of the facility user before, during and after the scheduled system test time. Figure 2-8 illustrates the various input and output data used in operational system testing. Some of the data are processed by the OS Jobshop during scheduled batch processing time.

The input data must be designed in accordance with the requirements of the function(s) to be tested. Often, the design is incorporated in a traffic sample which contains flight plans and contiguous operational action directives. The flight plans in the traffic sample, by their operational structure, establish the ATC situation in the system. Simulated surveillance data may be generated which simulate beacon aircraft flying scripted flight plans. If the ATCSF is employed, the traffic sample flight data are input to the Sigma computer to generate dynamically-controllable target reports to be transmitted to the ESSF 9020 systems. If live or recorded surveillance data is input, external tape equipment may operate with the system and console operators initiate aircraft tracks.

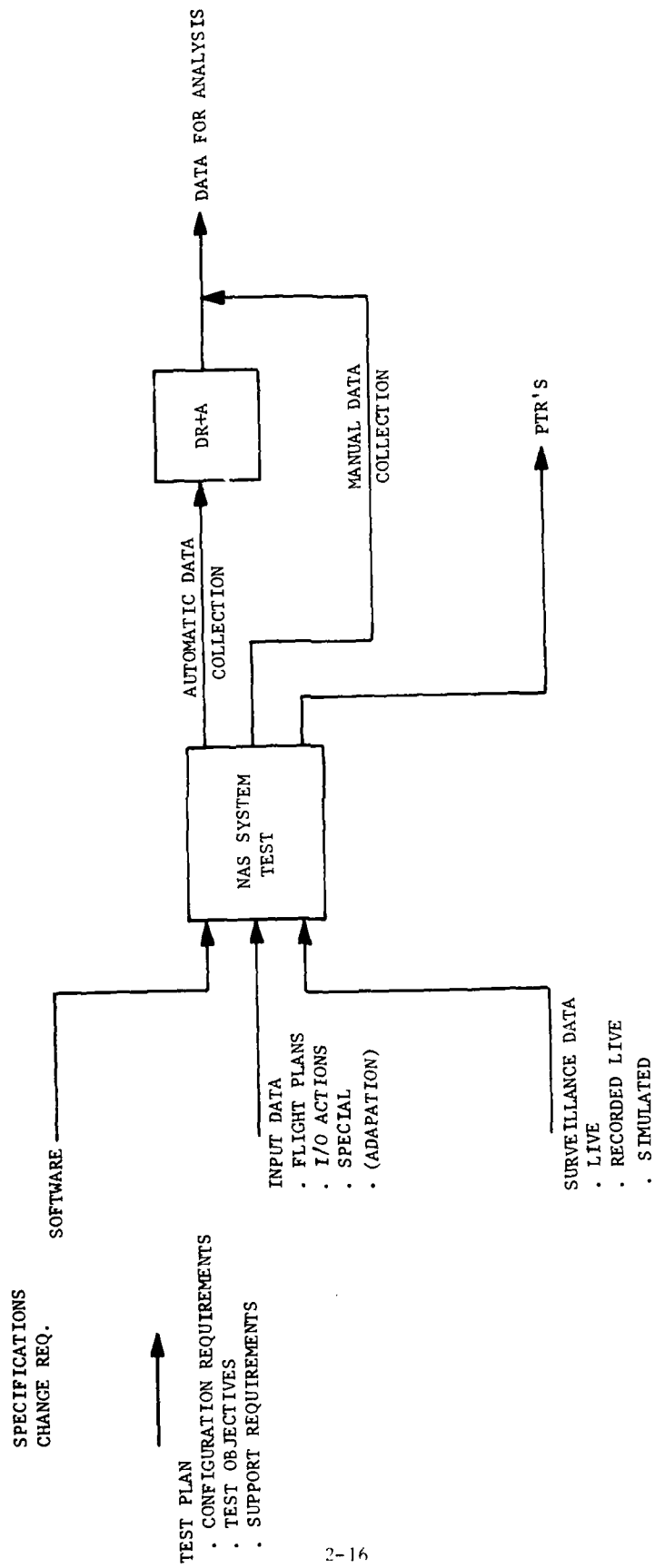

FIGURE 2-8 OVERVIEW OF ESSF SYSTEM TEST PROCESS

Prior to the test, the user must prepare suitable input data and the appropriate system software. During the test, data for analysis is collected. Recorded data and manually recorded logs are obtained. Recorded data are processed with Data Analysis and Reduction Tool (DART) software or other data reduction programs.

### 2.1.5.3 Observations of ESSF Operations

Some observations related to the current use of the ESSF for system testing are as follows:

- . Input data to the system is prepared on punch cards to be submitted for off-line processing. The generated tape or tapes, is (are) used as input to the system test. The EAM facility which punches the cards (small jobs are frequently performed by the user) is often oversubscribed resulting in turn-around time of greater than 24 hours.
- . For system tests which use live or recorded live surveillance data and operators at the R-positions, all input actions may be processed off-line to produce a tape which reconstructs the system inputs referenced to time and position console. A test with live or recorded live surveillance data could therefore be repeated using the tape for successive tests, if there were automated time synchronization between the surveillance tape and the CCC. In the current environment tests cannot be completely duplicated because no automatic, continuous time synchronization is available.
- . Post-test activities often include problem solution and off-line job submission for Data Analysis and Reduction Tool (DART) processing. DART is normally run on the OS Jobshop. DART jobs often require greater than 24 hours turn-around time. When there is an increase in system test activity, there is usually an increased DART activity.

The user must ordinarily become familiar with the NAS monitor, NOSS and OS usage, DART, ESSF interfaces, and the NAFEC scheduling procedures in order to run a successful system test in the ESSF. Furthermore, there are numerous software packages under NOSS and OS which are used to satisfy test objectives.

When system testing is conducted, the following actions must be taken:

1. The user provides the computer room operator with card deck(s) and tape slot numbers (or the physical tape if some time is to be saved) and an operating request slip. It is necessary to insure that PAM switching requirements are met.

2. The user calls the display channel computer facility, identifies the display program to be loaded, and calls for a transfer request to bring the display channel on-line with the CCC.
3. The user may load the cards in the reader but the user is not permitted to operate the control console or associated IOT devices. The user may advance the printer and tear off his paper.
4. If a digital tape (FR1800 or Saginaw) is to be used, the user must coordinate with the technician downstairs to bring up the tape and CCC in synchronized time. There is no automated means for doing this.
5. If another facility is to be interfaced with the 9020, the user must call the other computer room and synchronize the 9020 problem time with the external system time. There is no automated means for doing this.
6. If a data communications interface is to be established, the user must verify the MODEM interface during scheduled test time.
7. If the user is using the TESDATA MS68, he must be knowledgeable regarding the TESDATA probe connections, and he must load and operate the MS68.
8. If the DABS FEP is used, the user must go downstairs to enter a "dummy address" whenever the central computer system is restarted.

Currently, user personnel generally learn the requirements for operating in the ESSF by talking to enough knowledgeable ESSF personnel and becoming expert in the NAFEC system interfaces and operations. Because the users are usually NAS-oriented and knowledgeable, learning the ESSF interfaces, although time consuming, is not especially difficult.

To function properly, the system requires input data which simulates operational ATC, and which satisfies the requirements of the NAFEC environment. Submitting off-line jobs to generate input data requires ATC knowledge and NAFEC experience on the part of the facility user. The learning process has in the past involved trial-and-error job submissions until usable data is successfully generated.

The same trial-and-error learning principle, applies both to off-line DR&A jobs and to executions of system programs. A facility user must be aware of COMPOOL IDs, channel assignments and program load tape IDs, all subject to change.

#### 2.1.6 ATC Facility Simulations: Adaptation

The en route computer system requires a data base adaptation to define the physical and environmental characteristics of the facility in which the system operates. Besides the map and airways structures, the adaptation defines the addresses for the system interfaces, and the characteristics of surveillance sites.

In the ESSF, the operating system uses a specially designed set of adaptation data known as the Universal Data Set (UDS). The UDS represents a fictitious center. The UDS is intended to include all the characteristics which may exist in the field.

The UDS defines a geographic model which is unrealistic in the operational sense. The multitude of variations in geo-data, the unusual shapes of sector boundaries (Figure 2-9), and variations in airway assignments do not coexist in one operational site.

The following are observations which are generally agreed upon by personnel involved with UDS:

- . The UDS provides a usable tool for software development when the major considerations are related to data processing, not to ATC operations.
- . With UDS, system builds cannot be tested at NAFEC for a specific site application.
- . Development of system features which involve man-machine interfaces, or other operational aspects, are better carried out using a site adaptation set instead of UDS.
- . The ESSF is oriented to data preparation and system testing with UDS. Aids to users, e.g., maps, laboratory equipment, PAM addresses, and sector assignments are UDS-based.

To satisfy the need for simulation of field sites, the operating services have obtained a software subsystem which converts site adaptation to assembled data usable at NAFEC. The system, called ACE-SIM, is fully documented, and will be soon released to users outside of AAT.

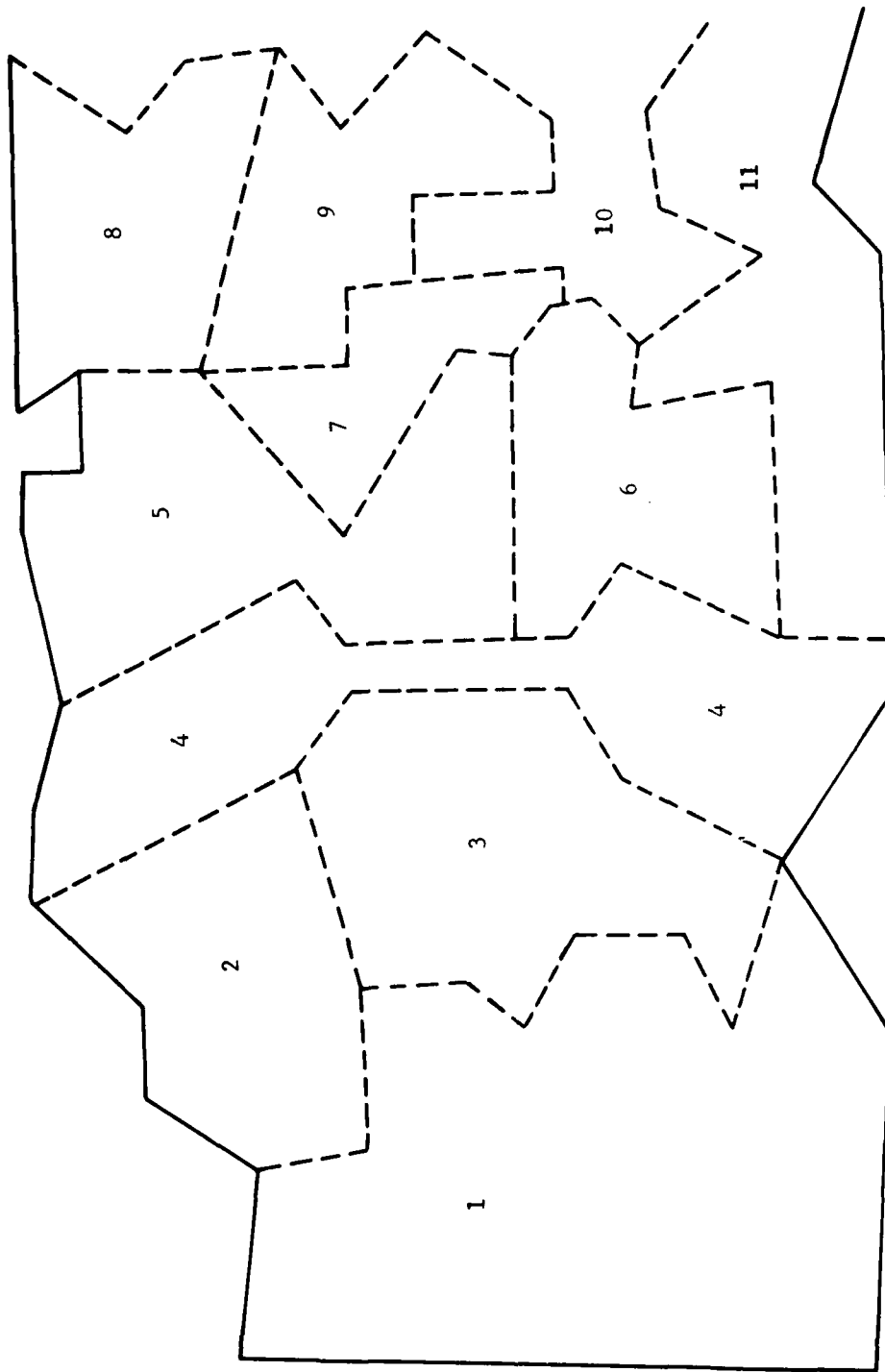

FIGURE 2-9 UDS LOW ALTITUDE SECTOR BOUNDARIES

The practice of "key-site testing"\* has been adopted by the field support services. With UDS and various hardware limitations there is no way to simulate at NAFEC the complete sectorization, geography, and interfacility operations which exist at a real field site. The capability to run selected adaptation sets in the NAFEC 9020 systems, with software substitutes for external devices, could reduce the length of time spent in key-site testing. In addition, the capability to run selected adaptations would provide a more realistic test bed for R&D projects which must simulate an operational environment. The expanded capability to be provided by ACE-SIM suggests increases in the demand for the following services:

- . 9020 off-line time to convert site adaptations to ESSF adaptation;
- . 9020 on-line testing more oriented to specific site applications for E&D as well as for field support;
- . Storage and handling facilities for tapes/discs from field facilities;
- . Laboratory map displays for varied field sites;
- . Adaptation automation in support systems, e.g., the ATCSF.

#### 2.1.7 Facility Scheduling at NAFEC

##### 2.1.7.1 Current Scheduling Practices

The Facility Control Office (FACO) schedules the 9020 systems in the ESSF. Figure 2-10 illustrates a segment of the weekly schedule. Although only two days are shown in Figure 2-10, the published schedule accounts for each twenty-four hour period for the 9020 systems at NAFEC. The schedules are produced as a result of requests for time which users submit using a request form.

The minimum time block which can be scheduled is 30 minutes. The shaded corners in the time blocks indicate that a display channel is required. If the 9020A blocks are shaded, the CDC is required. If the 9020E blocks are shaded, the E elements are to interface to the DCC Display Generators and will be driven by the 9020D as a display channel.

---

\* Key-Site Testing refers to the practice of testing and debugging a system on-site at a few chosen centers prior to nationwide release.

	MONDAY						TUESDAY							
	11/5			11/5			11/6			11/6				
	A	D	E	A	D	E	A	D	E	A	D	E		
	1	2	3	1	2	3	1	2	3	1	2	3	1	2
1														D
2														D
3														G
4														M
5														
6														
7														
8														
9														
10														
11														
12														
13														
14														
15														
16														
17														
18														
19														
20														
21														
22														
23														
24														

FIGURE 2-10 SAMPLE ESSF COMPUTER SCHEDULE

Other facilities which may interface with the 9020's, e.g., the ATCSF, ARSR and ASRs, are coordinated by the FACO scheduler personnel. Adjustments to the 9020 assignments are made as required. Continuous adjustments to the schedule are propagated to the various laboratories and facilities via an in-house teletype system. Updates which occur as a result of equipment outages, priority needs of the field support groups, or cancellations by users, are indicated to the laboratory managers and schedules are updated accordingly.

#### 2.1.7.2 Scheduling Observations

The user must submit his requirements to FACO two weeks in advance of the time desired. A weekly meeting of users or their representatives is usually convened at which details of the schedules are decided. This scheduling technique has been in effect at NAFEC for many years and has evolved into a routine which satisfies the majority of users and accounts for project priorities and the various complexities of interfaces and configurations in the ESSF.

The following observations were made:

- . The personnel who actually do the scheduling are extremely good at it. If a personnel change were necessary, there is a possibility that the scheduling efforts would suffer significantly. There are no software support tools used to facilitate the scheduling process.
- . The future installation of new ATC systems will require more complex scheduling adjustments to insure efficient facility usage.
- . The long scheduling lead-time (2 weeks in advance) makes planning difficult for the facility user and results in schedule requests which can be inefficient. Ideally, test time should be scheduled less than one week in advance.
- . A user's assigned time includes facility and/or system reconfiguration time. If the previous user ran a complex multi-facility test, the reconfiguration time for the next user may be high.

### 2.1.8 ESSF Enhancement Considerations

The current ESSF activities, as presented in Section 2.1.5, were considered in connection with the activities planned for the future development of ATC systems. This section considers various aspects of ESSF facilities and capabilities, and suggests ways in which the facilities might be enhanced to more adequately meet future needs.

#### 2.1.8.1 System Interface Requirements

During the mid to late 1980's, support to the field, as well as development of operational system enhancements, will require that the present 9020 operations continue concurrent with the introduction of new systems. For example, the ESSF will support system operations which interface 9020A, 9020D, ETABS, DARC, DABS and a display channel. ETABS may be operated with the new ATC Computer Replacement or with the 9020s via the interfaces to the IOCE selector channels, thus, requiring an expanded or modified switching capability.

With the addition of the new systems, the test configurations in the ESSF will become highly complex. The application of the NLSSS, combined with the new systems and interfaces, will provide a large number of configuration alternatives. The result will be that users will depend completely on NAFEC ATC laboratory personnel to verify system interfaces, advise on best operating techniques, and help in the isolation of problems which occur in a facility or system.

NAFEC facility technicians will be required to operate the interface switches associated with the 9020 PAM's, Display Channels, DARC, TIPS, ETABS and other new systems or hardware. Often, the interfaces will be required to operate in a coordinated manner to insure that configuration changes for one user do not impact on-going testing of another user.

#### 2.1.8.2 Centralized Facility Switching Control

The implementation of the NLSSS will establish a central unit for controlling the data communications interfaces between a number of laboratories and systems. The principle of centralization, if extended to all switchable interfaces, would result in a unified operations center. For example, centralized remote control of all the interface switches would enable the NLSSS operator to set the following switching equipment which will be located throughout the ATC laboratory:

- . NCSS
- . PAM interfaces to DRE
- . DABS FEP interfaces to PAM
- . 9020A/9020D PAM switch
- . DARC switch
- . ETABS switch

An indicator panel, part of a remote switching system, would enable the operator to continuously monitor the configuration of all systems in the ATC laboratory. The unified control of facility interface switching coupled with the configuration monitor would provide the following benefits:

- . Time required to reconfigure system interfaces would be significantly reduced;
- . Errors in switching interfaces would be less likely to occur;
- . Operation of a central configuration monitoring facility could be enhanced by implementation of software aids. A micro-computer could establish and verify configurations as directed by operator inputs.

The long-term result would be significant improvement in efficiency and reduction in the effort required to interconnect large numbers of signals and systems. (Limitations on cable lengths and cable run locations would impede the installation of all switch hardware in a central location. For this reason, a remote control of the interface switches would be required.)

#### 2.1.8.3 Multi-System Synchronization Requirements

A common time reference is required for tests in which computer systems are interfaced. Data from each system must be correlated for analysis. Currently, there is only limited time synchronization between systems which operate together through a manual synchronization procedure at start-up accomplished by telephone between the facilities which are interfaced. When more than two systems are frequently interfaced for testing, manual synchronization of the data processing systems contributes significantly to human error during tests, lost time for setup and for restart, and difficulties with data analysis.

The capabilities for time synchronization of interfaced computer systems in the NAFEC ATC environment should include the following:

- . Computer systems which operate while interfaced must be able to synchronize to a specific time-of-day value. The absolute value of the time of day might be realtime (WWV standard) or might be a test mission time corresponding to prescribed flight data requirements. A common time signal must be capable of being set to a value as specified by the scheduled user of the multi-system configuration.
- . During tests, when events occur which result in complete restart, it must be possible to reset and freeze the mission start time to allow the interfaced facilities to reload and initialize software.
- . When human intervention is not required and ATC operations are not to be simulated, it should be possible to check recorded flight data, surveillance data and keyboard input/output data in fast-time. The fast-time capability provide for a more efficient testing in that the time required for a particular test is reduced considerably.

In late 1980, the NAFEC Laboratories Signal Switching System (NLSSS) will interface the data communications between virtually all ATC laboratories and facilities at NAFEC. With the NLSSS in place, a time-of-day signal may be easily distributed to facilities which are interfaced for system test. Appendix D illustrates a concept which uses the NLSSS to distribute a clock signal to computer systems/facilities which are interfaced for testing.

#### 2.1.8.4 Facility User Orientation

Over the period of development of the next generation of ATC systems, new personnel will use the NAFEC facilities. Adequate orientation of personnel to the en route and terminal ATC data processing system, operational terminology and practices, and the special capabilities and requirements in the NAFEC ATC laboratories, will become more significant.

The facility user, in order to become familiar with the requirements for successful testing, will need a source of information other than that gained from "hands-on" experience in the laboratory. The facility users--system analysts, programmers, or ATC specialists--will look to NAFEC for the following kinds of information:

- . Basic ATC concepts, operations, and practices;
- . ATC computer processing capabilities available at NAFEC for support to systems testing;
- . NAFEC practices and procedures for facility utilization;
- . NAFEC facilities descriptions, including radar sites, range control facilities, current test programs, and related data-bases;
- . Current equipment status, system availability, and identification of up-to-date software system versions.

With an increase in activities and in personnel, the need for effective information dispersal will become extremely significant.

To satisfy the projected need for fast indoctrination of NAFEC facility users, an automated audio/visual briefing center could be constructed as an integral part of the Technical and Administrative Complex. The center, available to all personnel, would provide selectable levels of briefings, orientations, and data on system parameter values. Status of laboratory equipments and schedules could be included.

Information which seldom changes (e.g., basic ATC, NAFEC procedures and capabilities) could be presented on small projection screens with stored presentations selectable by the viewer. More technical data or information could be addressable via a computer terminal which could supply the responses to inputs in an interactive mode.

Appendix E suggests an outline of three information topic groups, each designed to satisfy the needs of personnel at various stages of expertise in the NAFEC ATC environment.

#### 2.1.8.5 Scheduling Requirements

As indicated in Section 2.1.3, the system configurations in the ESSF will be integrated with a number of new systems during the next 5 to 10 years. With the new systems, an expanded capability will evolve at NAFEC. To efficiently use the capabilities, accurate response to the scheduling needs of users will be required.

To make the scheduling of facilities more responsive to the needs of the users, the facility scheduling process should be enhanced to produce the following benefits:

- . Reduction in the time required for determining configuration requirements for the various systems which will be under scheduling control (i.e., 9020A, 9020D, ETABS, DABS, DARC, ARTS III, TIPS, ATCSF, and special instrumentation systems).
- . Reduction in the time requirement for the prepared schedule to be duplicated (currently, a completed schedule is mailed to the print-shop, reproduced and distributed from there).
- . Reduction in the time requirement for the prepared schedule to be distributed to the NAFEC organizations.
- . Reduction in the manual paper handling workload for scheduler personnel.
- . Reduction in the probability of scheduling inefficiency or error.

Each of the above would contribute to a reduction in the lead-time required for NAFEC facility scheduling.

The use of automation aids to accomplish the above benefits should be explored. To be effective, a system to aid scheduling would require access to a terminal interfaced to an interactive system. Functional characteristics of an automated scheduling program should be developed for use with an interactive system at NAFEC. Basic functions of a scheduling program would include, but not be limited to, the following:

- . Classifying and sorting requests from users;
- . Error checking and flagging inconsistent requests for computer systems;
- . Determining the impact of schedule changes on facility usage;
- . Outputting printed schedules for reproduction and distribution.

If, as discussed in Section 2.1.8.4, an automated capability for dissemination of information to the facility users is instituted, the requests for computer/facility time and the formation of a schedule could take place without request forms, yard mail or manual manipulation of paper. The scheduling software could evolve to handle schedule requests, configuration determinations, and schedule time assignments with only little intervention from the scheduling personnel. The result would be an increase in scheduling efficiency for the NAFEC ATC facilities.

#### 2.1.8.6 Facility Considerations for ETABS Control Sectors Installation

In mid-1980, the ETABS System is to be delivered to NAFEC. The ETABS engineering model will include six ETABS ATC controller position consoles. The six consoles will replace six D and A controller positions in the 9020D ATC laboratory. (Figure A-3 describes the current floor plans for the NAS en route laboratories.) The implication in the arrangement is that the ETABS must always operate with scheduled 9020D computer time. The 9020D will drive the display channel and interface with the ETABS system. With this arrangement, two restrictions are implicit:

- . When the DCC laboratory supports testing for projects other than ETABS, the six positions will continue to incorporate the ETABS equipment. The location of the engineering model consoles would present a problem if the laboratory user needs to operate a large scale simulation complete with D and A controllers at the six sectors occupied by ETABS.
- . The location of the ETABS positions in the DCC laboratory imposes restrictions on the flexibility of the ETABS development effort:
  - . ETABS will require a 9020D, if contiguous PVDs are to operate,
  - . ETABS will not be operated with an interface to the 9020A.

## 2.2 Terminal Automation Test Facility (TATF)

### 2.2.1 Current TATF Operations

The TATF houses computers and peripherals which comprise a number of Automated Radar Terminal System (ARTS) configurations. Development of the ARTS IIIA system and of the ARTS All Digital System (ADS) currently requires a large percentage of TATF resources. As indicated in Appendix B, which discusses in more detail the systems in the TATF, the TATF resources are built upon three ARTS III systems. Each system includes two Input/Output Processors (IOP's) with assigned memory. Through the IOP Input/Output Channel assignments interfaces with the peripherals are established. TATF peripherals are shown in the TATF system overview in Figure B-1.

Certain peripherals, e.g., the Communications Modem Controller (CMC), are necessary for test and development of DABS. The CMC is interfaced with ARTS III system #3 in the TATF and the DABS test activities require scheduled time on system #3 for testing and data collection. System #1 is used for ARTS IIIA development and system #2 is used for off-line support work and for operation of a Radar Beacon Simulator (RBS), which generates simulated surveillance data for system input.

Development software is coded for system tests by the UNIVAC Corp., under direction of test designers. Off-line support software is available and is used normally for jobs to be run during non-working hours. Job submission forms are required for operator's instructions. A library stores computer tapes and discs assigned to facility users.

Currently, the TATF computer facilities and the terminal display equipment are adequate to support the level of test and development activities which are under way. As discussed in Appendix B the patching hardware and facility support from software systems have evolved with the development of the ARTS III systems. The evolution to be expected over the next period of development of ATC systems (1980-1990) will result in the installation in the TATF of new systems, increase in support requirements and requirements for system integration and testing. The sections which follow discuss these new systems, their impact on the TATF resources, and suggest a method for enhancing the future configuration capability.

## 2.2.2 Future System Installations in the TATF

### 2.2.2.1 Terminal Information Processing System (TIPS)

In the new T&A complex at NAFEC the TATF is planned to be located directly under the Experimental Tower Cab, which will occupy space on the roof of the ATC laboratories. The TATF and the Tower Cab will support the installation of the Terminal Information Processing System (TIPS). The TIPS system (described in Appendix C) will be installed in mid to late 1980, with variations in equipment complements occurring as development of the system continues. The first installation phase includes a Terminal Flight Data Processor (TFDP) with a TRACON Display Processor (TRDP), a Tower Display Processor (TDP) and three Display and Entry Devices. The installation at NAFEC will include a special patch panel, which will facilitate the patching as illustrated in Figure 2-11. The ARTS III system(s) may operate without TIPS (Mode 1), or, the terminal, en route and TIPS systems may operate together (Mode 2), or, TIPS may operate with the en route system without the ARTS III (Mode 3). Each of the modes is expected to be used during various stages of development of the TIPS functional capability.

### 2.2.2.2 ATC Computer Replacement Program

The ATC computer replacement may include TIPS as part of the overall replacement system, or, may replace terminal processors with large central computer systems to process both en route and terminal data. At this time the scope of the replacement system is not firmly defined. The TATF could be required to support the on-going E&D activities of the various terminal programs as well as the installation and development of the replacement computer system. The system interfaces, facility support and software capabilities should be planned prior to the installation of an ATC replacement system test bed. To facilitate the associated planning, the progress of the ATC computer replacement program must be continuously monitored and inputs to NAFEC facility planning prepared in accordance with forecasted test bed requirements.

### 2.2.2.3 Tower Cab Systems

Other systems being developed for use at terminal sites include the following:

- . Visual Confirmation of Voice Takeoff Clearance (VICON)
- . Low Level Wind Shear Alert System (LLWSAS)
- . Vortex Advisory System (VAS)
- . Airport Surface Detection Equipment-3 (ASDE-3)
- . Tower Automated Ground Surveillance System (TAGS)

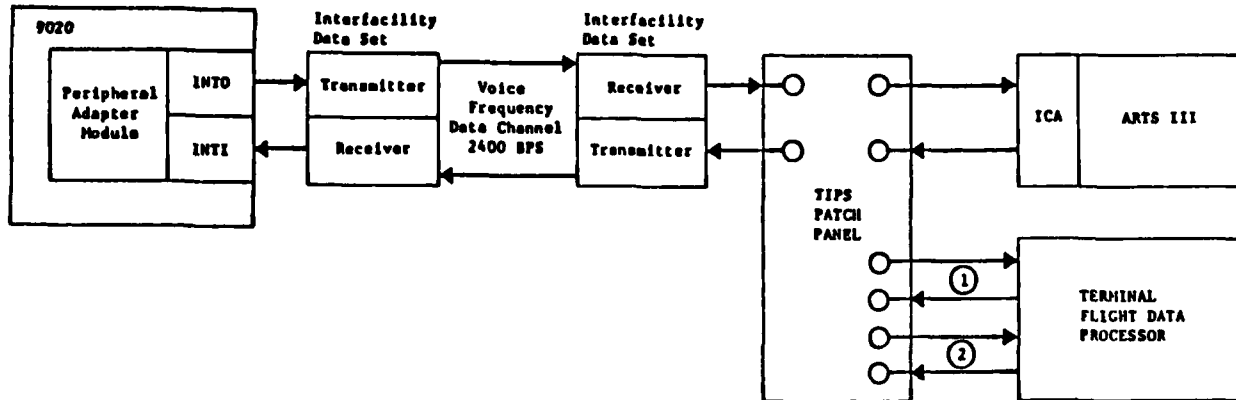

MANUAL MODE PATCHING

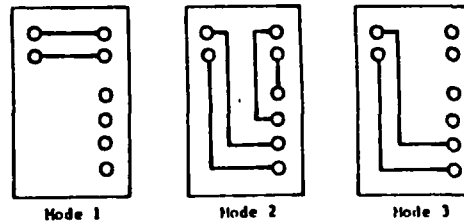

FIGURE 2-11 NA FEC TIPS PATCH PANEL CAPABILITY

These systems are in various stages of development and field implementation. At NAFEC, a tower cab console model was built to demonstrate the installation of the control panels for the tower cab systems, including the TIPS consoles. Over the long-term the control consoles for the tower cab systems and for the TIPS system could be collocated in the experimental cab at NAFEC for development of combined functional capability.

### 2.2.3 A Suggested Enhancement to the TATF Test Bed Capability

#### 2.2.3.1 Long-Term Need for Flexibility

In addition to the system development activities now under way in the TATF, the TIPS system development must be supported. TIPS will require the ARTS III and en route systems for test support during various phases of the development activities. The ATC computer replacement, if it includes the terminal capabilities, will become a major load factor in the TATF in the 1985-1990 time-frame. In the future a system configuration which includes ARTS III ADS, DABS and TIPS must be established to validate software compatibility and to evaluate the operational capabilities provided by a completely integrated terminal system. To develop software for the various systems, testing with the TATF systems will frequently require configuration changes and the establishment of interfaces with systems external to the TATF.

Currently, the flexibility of equipment reconfiguration in the TATF is limited. The TATF would become more responsive to varied resource requirements if interfaces between different IOP systems were variable. Because the IOP's serve as a central data processing point for all peripherals, flexibility in IOP configuration would provide flexibility in the use of any of the TATF systems and peripheral equipments. The benefits to facility usefulness would be as follows:

- . Scheduling of separate tests for various projects would not depend on the availability of a specific hardware component;
- . Equipment failures would not impact one development activity to the exclusion of the others;
- . Off-line processing could be accomplished with support from any IOP and from any 9300 system, which would increase the job throughput. (If a number of terminal/tower projects take place at the TATF, the off-line support load will increase and will impact schedulable test time.)

#### 2.2.3.2 A Suggested TATF Switching Capability

Figure 2-12 illustrates the systems and interfaces which are expected to be installed in the 1980-1985 time-frame. Three ARTS III systems are assumed to continue to exist. Three systems are added to the current systems as illustrated in Figure B-1. These are the NLSSS, TIPS with tower cab instrumentation, and a proposed IOP Configuration Channel Control system (ICCC).

The ICCC is suggested as an automated switching system to enhance the flexibility of the TATF. The ICCC would allow IOP channels to be assigned for any use. The ICCC control position consists of a keyboard and CRT terminal. An operator would control the IOP configurations as required. Standard configurations for the majority of tests would be stored on punched cards, paper tape, or similar devices. The operator would modify configurations as required due to:

- . equipment failures
- . new test requirements as indicated on the facility schedule
- . system configuration changes for priority scheduled users.

#### 2.2.4 Multi-Facility Testing Considerations

The ARTS III equipment in the TATF must frequently be interfaced with systems external to the TATF. These include surveillance sites, the ATCSF, and DABS sensor sites. Future activities will include the TIPS interface and more frequent interface with the en route computer systems. The sections below discuss some of the problems encountered when the TATF systems are used with external facilities.

##### 2.2.4.1 Establishment of Multi-System Configurations

There is no standard, fast interface set-up and verification procedure to facilitate test reconfigurations. The result is that scheduled users must initialize the computer systems under test to verify interfaces with external facilities or computer systems. The time required for interface verification results in non-productive test time. Often, problems in system software may appear as a data communications interface problem, resulting in lost time for troubleshooting.

The installation of new systems at NAFEC (see Section 2.1.3.1), such as the NLSSS, will reduce the problem. It will, however, be necessary to insure that all TATF interfaces with external facilities are established through the NLSSS, and that no circumvention of the switching system control occurs.

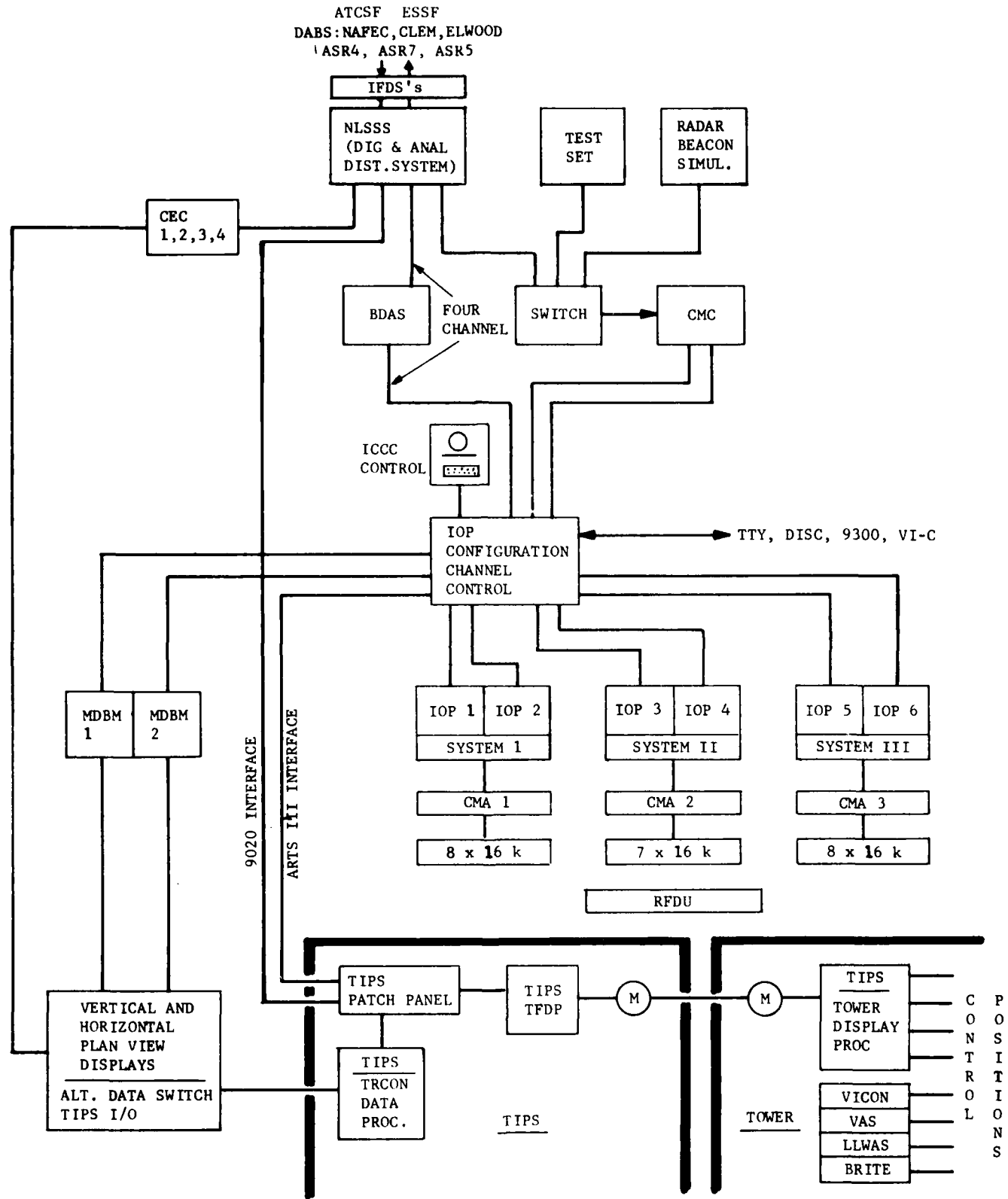

FIGURE 2-12 PROPOSED TATF SYSTEM CONFIGURATIONS

#### 2.2.4.2 Use of Voice Communications in the TATF

Voice communications between the display room (simulated TRACON) and the computer room are not adequate. The test analyst must leave the radar displays and walk to the computer room for restarts, tape mounts, or other actions. Voice communication to other facilities, e.g., the ATCSF, is accomplished over the administrative telephone.

The installation of the NAFEC Communications Switching System (NCSS) in the laboratories will reduce the problem of voice communications within the TATF (see Section 2.6). Until the NCSS is installed, an interim voice system should be made available to provide effective communication between the terminal display room, TATF computer room, TIPS processor and the Tower Cab.

#### 2.2.4.3 Time Synchronization

No common time source (time-of-day set for the test environment) is used in the TATF. The resulting problems similar to those in the ESSF are inaccuracies in data analysis, delays in system initializations and limited ability to fast-time simulations. As discussed in Section 2.1.8.3, a central time-of-day system should be established at NAFEC with the capability of providing a signal to each of the interfaced systems via the NLSSS.

#### 2.2.5 TATF Support to Field Operations

In the mid-1980's TIPS, ARTS IIIA, ARTS III ADS, DABS, and various tower cab systems will be deployed in the field. As the various field installations occur, support from NAFEC with configuration controlled systems is expected to continue. At this time, the Terminal System Support Facility (TSSF) contains ARTS III systems dedicated to field support and represents a separate facility established for that purpose. The complexity and cost of integrated surveillance terminal/tower cab systems could begin to prohibit separate facilities for R&D and for field support. The TATF, which is currently used for field support when the TSSF is unavailable, could be required to provide more support to the field while continuing operational development of a number of terminal systems. A long-term plan is required which considers the interfacing requirements for the TATF systems along with the requirement for configuration control and configuration flexibility.

### 2.3 Flight Service Station Facilities Automation Program

A Flight Service Station (FSS) experimental laboratory is to be installed on the second floor of the new T&A complex. The laboratory will house computer systems and console equipment to be used in the development of an Automated FSS (AFSS) system. Appendix F describes the overall capability of AFSS, and presents a simplified overview of the Flight Service Data Processing System (FSDPS) interfaces with the Aviation Weather Processor (AWP) as well as with other ATC facilities in the field.

To develop the AFSS, Model 1 and Model 2 systems have been specified. The Model 1 system will be delivered to NAFEC in two phases, referred to as Packages 1 and 2. Figure 2-13 illustrates the Model 1 system; the Model 2 capability, which will be installed in the NAFEC laboratory, is illustrated in Figure 2-14.

#### 2.3.1 NAFEC FSS Installations

The Model 1 system, which is scheduled for delivery in February, 1981, consists of only a Flight Service Data Processing Center with interfaces. Data to the FSDPS is to be provided from Service 'A' teletype (TTY) to the Weather Message Switching Center (WMSC) and the Service 'B' TTY network. The flight service data files in the FSDPS Model 1, Package 1 at NAFEC will be limited to pre-canned routes of flight. The data from the WMSC will update the weather information for the pre-canned routes.

In Model 2, a second FSDPS will support experimentation and enhancements. Current planning calls for the Model 2 instrumentation and equipment to be available at NAFEC in October, 1982. Interfaces to the external facilities (AFOS, WMSC) and to the en route computer system will be required to support the engineering and development activities.

#### 2.3.2 The Impact of the FSS Laboratory on the ATC Test Bed

The initial installation of the FSS laboratories does not require interfaces with other computer systems within the ATC laboratories. The initial installations should therefore be completed with no impact on the other development activities.

Over the long-term (post 1982), interfaces will be required between the FSS laboratory and other facilities. The following considerations should be taken into account for long-term planning:

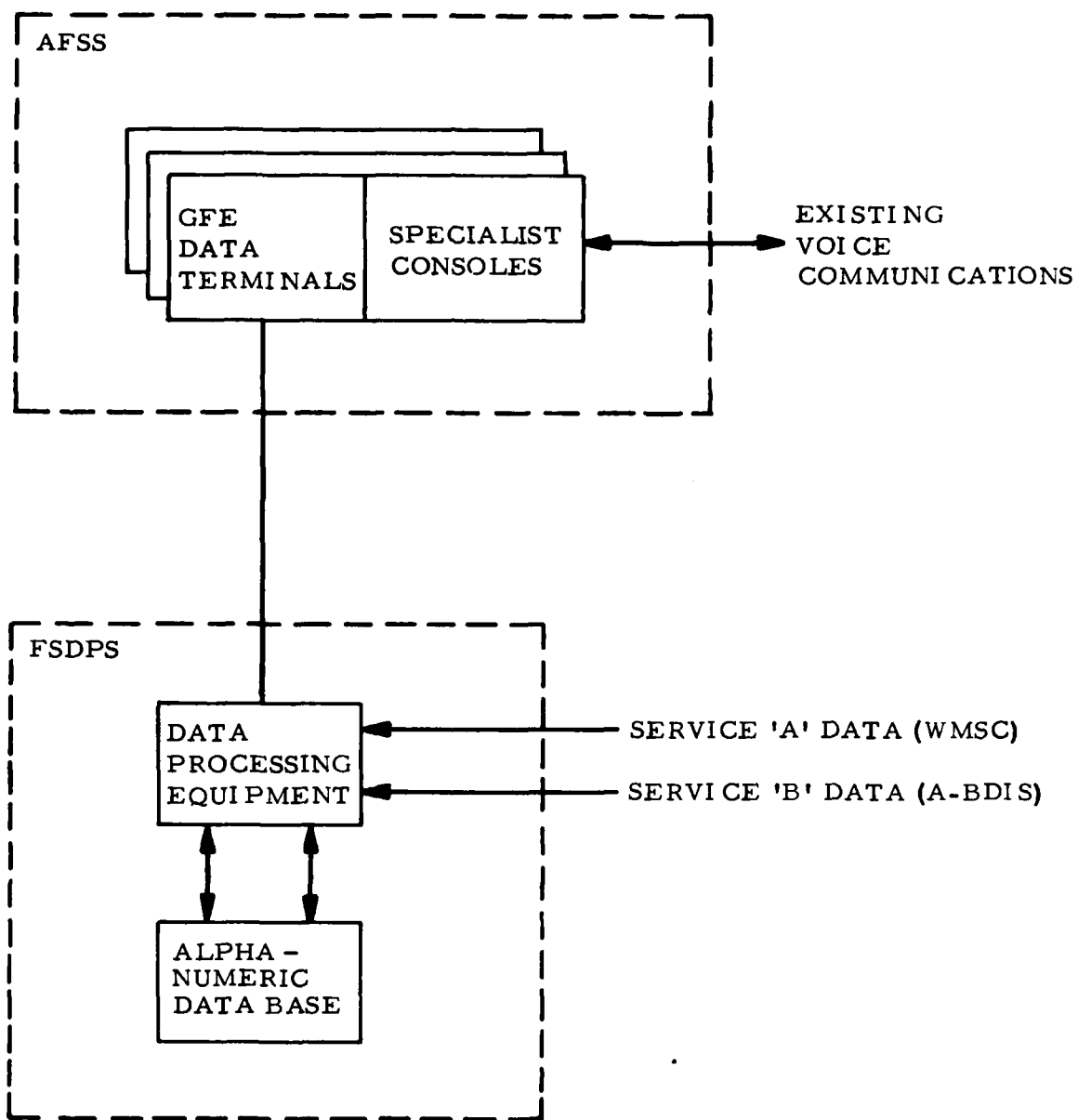

FIGURE 2-13 MODEL 1 AFSS SYSTEM CONFIGURATION

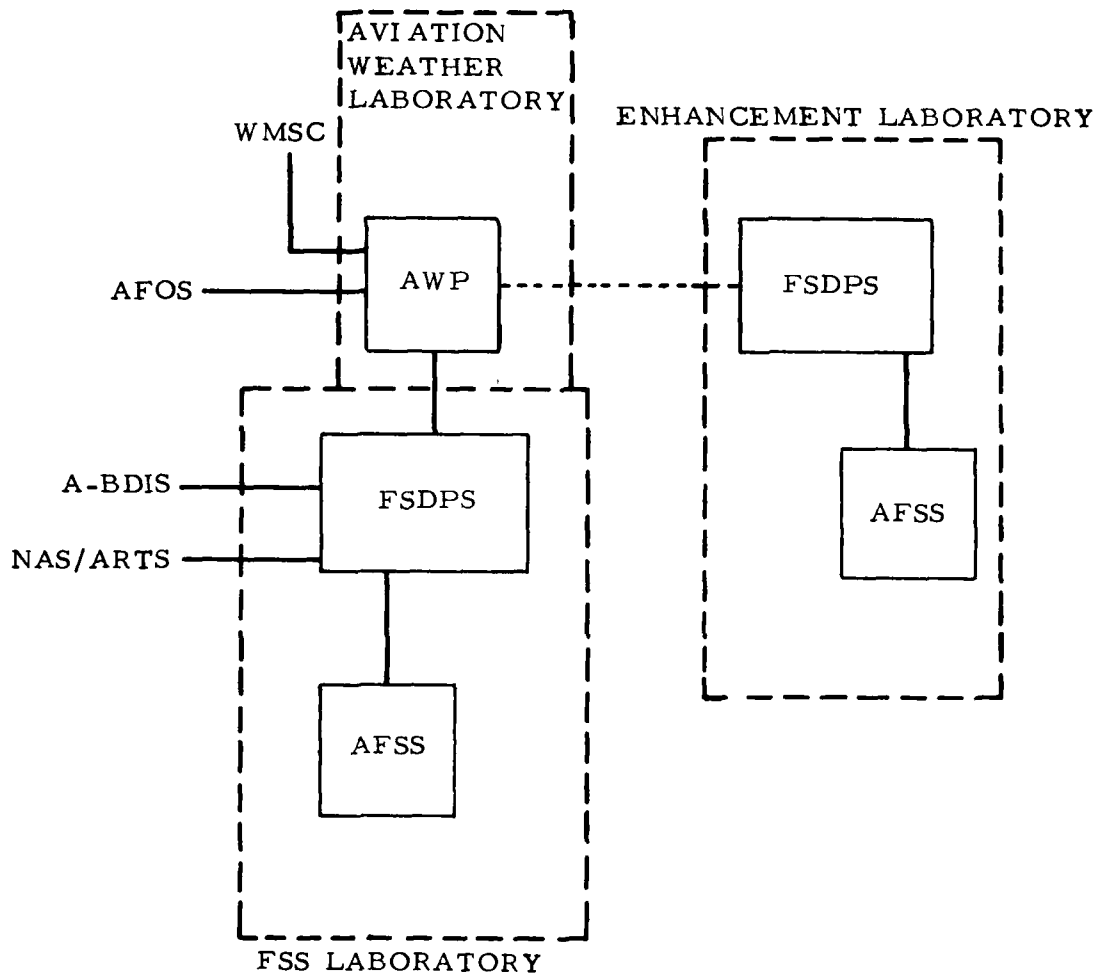

FIGURE 2-14 MODEL 2 AFSS SYSTEM CONFIGURATION

- . The FSS interface with other computers or facilities will remain fixed over long periods of time. Interfaces to communications networks via NADIN or leased telephone lines, and interfaces to the 9020 will not need to be frequently varied.
- . The FSS laboratory environment will not require the voice communications capability of the NCSS until the Model 2 system is being developed. According to FSS project managers, the interim voice system will be adequate for E&D activities with the Model 1 FSS laboratory.
- . The FSS system eventually will need to interface with the en route computer system. The en route software must be coded to operate with the FSDPS software. Some development time with the en route system will be required. The interface consists mainly of transfer of flight data; only a short development cycle should be required for the en route software development.

#### 2.4 Air Traffic Control Simulation Facility

The ATCSF, currently housed in building #19 at NAFEC, includes a number of computers, interface equipment and operator consoles which are described in the ATCSF User's Guide. The major system elements to be relocated to the new T&A complex include the following:

- . XEROX SIGMA 5;
- . XEROX SIGMA 8;
- . 48 simulated pilot consoles
- . Surveillance distribution system which couples data from the computers to the MODEMs;
- . ATC control room which houses Plan View Displays

A study is being conducted by the FAA to determine ATCSF requirements for future FAA projects. The study results will be used to refine the long-term plans for the ATCSF.

The long-term ATCSF development plan identifies three levels of capability to be achieved during the 1980-1986 time-frame. Table 2-1 lists the major capabilities for each of the levels. Three major objectives for the ATCSF were stated as follows:

TABLE 2-1

ATCSF PLANNED CAPABILITY

. Initial New Building Capability

Sigma 5; Sigma 8 upgraded to Sigma 9 (with old peripherals and old memory)  
New Displays (ARTS Digital; Time-Shared not to be available)  
48 Pilot Positions  
Special Interfaces  
Existing Software

. Level 1 Capability (1982)

Two New Central Processors  
One Megabyte of New Memory  
New Computer Peripherals  
Voice of Recognition System (to be phased in)

. Level 2 Capability (1984)

Two New CPU's  
.5 Megabyte Additional Memory  
New Software system  
Mobile Laboratory (to visit field sites and establish interface to NAFEC for tests)  
Additional Peripherals  
Additional ATC Capability/Capacity

. Level 3 (1986)

One More CPU  
.5 Megabyte New Memory  
More Peripherals  
More Voice Recognition Capability  
Fewer Pilot Positions (16, supplemented by expanded voice recognition)  
Additional ATC Capability/Capacity

- . To provide a realistic environment for the evaluation of new ATC concepts;
- . To reduce the costs of facility operations software and staffing;
- . To provide access to test subjects by use of a mobile laboratory.

Because planning for the ATCSF has already been performed to a great depth by the FAA, the remainder of this section limits discussion of the ATCSF to the capability as it relates to en route and terminal system projects in the other test facilities at NAFEC.

#### 2.4.1 Long-Term Considerations for the ATCSF

A significant increase in demand for the ATCSF simulation capability can be expected in the future. The ATCSF is expected to provide the following functions for future T&E activities:

- . Simulate DABS, ATCRBS or search-only aircraft, and DABS data-link capability;
- . Provide the vehicle for evaluating controller-pilot interactions;
- . Generate large quantities of data to provide heavy processing loads to the en route or terminal systems;
- . Support simulations of multi-DABS sensor operations.

The ATCSF provides a unique capability to support system development, such as the DABS data link. This capability must be augmented by enhancements which parallel enhancements to the en route and terminal systems. Specific ATCSF enhancements are as follows:

- . Simpler method to define flight trajectories and characteristics for surveillance data simulation. Currently, flight characteristics for surveillance data are defined by fix to fix segments, must be pre-stored and are not definable in terms of a surveillance system grid. Specific flight paths rely on the current adaptation list of location identifiers which are assembled for use as an on-line data base. This data base, called "Link 1" data, must be used when any surveillance data is generated, thus limiting the flexibility of the surveillance data simulations. The capability to simulate surveillance data which is not related to fixes or airways, (e.g., data which flies radials from sites) would enhance the useability of the ATCSF as a target generator for surveillance development activities.

. Automated Adaptation Assembly. A software system, called "ACE-SIM", has been developed by AAT-550 to convert adaptation data from an en route center to a form usable in the ESSF. User options allow assignment of any of the field site control sectors to any of the eleven positions in the NAFEC laboratory. This capability, when it is available for use by E&D activities, can be used for a number of system development activities such as operational DABS testing. The ATCSF must operate with adaptation from the same field site as the interfacing system if the ATCSF is to satisfy the need for test support. Changes to adaptation stored at NAFEC which reflect changes indicated by the field must also be reflected in the ATCSF data. Currently, the adaptation is manually coded into the ATCSF system. An automated capability for adaptation assembly into the ATCSF systems should be developed, to reduce time required for adaptation builds.

. Time Synchronization. If as recommended in Section 5.1.2, a capability for distribution of master time synchronization signals is adopted, the ATCSF will need to be modified to incorporate an option to accept an external time-of-day signal. Time synchronization is especially important in the ATCSF in the following support areas:

- 1) Scenario generation - surveillance data flight paths must match flight data stored in interfaced en route and/or terminal systems. Start times and maneuver timing require a common reference;
- 2) Data reduction and analysis - often, the data from several systems must be time correlated for data reduction and analysis.

## 2.5 NAS Jobshop Facility

### 2.5.1 General

The primary function of NAFEC's computer jobshop facility is to process computer runs that are submitted for execution in batch mode. These are commonly referred to as "remote jobs" since they are normally processed without the user being present during the run. NAFEC's jobshop facilities provide the off-line capabilities needed to support the development and maintenance of the NAS en route system. Essentially, the jobshop handles two types of jobs, as classified by the software operating system:

#### (i) OS/360 jobs

These jobs are processed under the control of the OS/360 operating system, which was modified to operate on the 9020 computer. The user specifies whether the job should be run under either the OS/MVT or OS/PCP operating systems.

#### (ii) NOSS jobs

NOSS is the original operating system for NAS support and is the predecessor of OS/360 at NAFEC.

A dedicated 9020A computer system--the "C system"--was established to process OS/MVT jobs exclusively. This system is usually referred to as the "OS/MVT jobshop". It processes OS/MVT jobs submitted in one of two ways: (1) remotely through SUPERWYLBUR (see Section A.7), and (2) using card decks delivered to the process control desk in Building #149. Figure 2-15 shows a copy of the job request forms for OS and NOSS jobs. NOSS jobs, as well as OS/PCP, can be processed on the other 9020 systems in the ESSF.

When work on the OS/MVT jobshop exceeds its capacity, OS/MVT jobs are diverted to the other 9020 computers on an as-available basis. Another schedule variant occurs when some users schedule hands-on sessions to run OS or NOSS jobs.

### 2.5.2 Operations

#### 2.5.2.1 Process Control

Remote jobs submitted by the users (other than through SUPERWYLBUR) are handled by the Process Control team which allocates the jobs, to the respective computer systems. The Process Control Team decides whether a particular OS/9020 job will run on the 9020 jobshop system



or be off-loaded to any of the other systems capable of processing OS jobs. The Process Control Team also handles special requests for dedicated computer time, and attends to problems encountered by the users.

#### 2.5.2.2 Work Shifts

The 9020C system operates 24 hours per day, 5 days per week. (Note that a 40% increase in availability could result with weekend operations.) SUPERWYLBUR operates between 0700 and 2300, 5 days per week.

#### 2.5.2.3 Accounting

Three types of accounting information are provided:

##### (1) Utilization Reports

Every month, summary computer utilization reports are produced accumulating for each computer system and for each user the amount of total computer time use, remote and hands-on usage, and total productive and non-productive time for each system. These reports are generated from information logged by the computer operators providing the elapsed time for each job or activity. Note, that these reports reflect only the elapsed time for each job and not the amount of actual processing time.

##### (2) Cost Accounting Reports

These reports are produced monthly by the NAFEC Accounting Division. The basic data is the computer operator's log as described above. The elapsed time used for each project is converted to dollars to provide total cost information for each project.

##### (3) OS/SMF (System Management Facilities) Reports

SMF, an optional feature of OS/360, collects system, job-management, and data-management information during OS operations. This data can be subsequently reduced to provide various accounting information on computer resource utilization and system performance. At NAFEC, a Value Computing Inc. software package is used to reduce SMF data, and produce the accounting reports. These reports apply only to operations under OS/MVT. The reports are used by the NAFEC system support staff for system monitoring and tuning.

#### 2.5.2.4 Users

The major users of the jobshop facilities are the NAFEC tenant organizations, AAT-550, AAF-360, and ARD-140, including their contractors, primarily CSC and OAO. AAT-550 is considered to have top priority for jobshop usage, at times superseding all other users for processing special high-urgency jobs. Frequently, AAT-550 schedules blocks of several hours each of jobshop time on a dedicated basis (i.e., preempting all other users).

#### 2.5.2.5 Turnaround Time

An unwritten but generally accepted goal for NAFEC's jobshop operation is to achieve a 24-hour turnaround time, i.e., the elapsed time from job submission to delivery of output. Usually, this goal is met. However, based on discussions with several users, roughly 10 to 20% of the jobs submitted took more than 24 hours. It should be noted here that a 24-hour turnaround time, in today's standards, is quite excessive, especially for typical compilations or assemblies, and quick executions.

#### 2.5.2.6 9020 Jobshop Upgrading Efforts

From the inception of the jobshop, several steps have been taken to upgrade its capabilities and efficiency. The replacement of CRJE by SUPERWYLBUR is one such improvement. Additional disk units and main memory space were installed. Another area that was improved is the communications between the jobshop and the user terminals, enabling more terminal users to interface with the system at the same time (32 telephone lines were available as of July 1979). Some attempts to upgrade the jobshop were unsuccessful. Several years ago, IBM, under contract to the FAA, developed MP9020, a modification of OS/MVT designed to utilize an additional 9020 CE and an IOCE, so that the jobshop can operate as a dual-processor system. This effort, however, was unfruitful and did not materialize. Another attempt to upgrade the jobshop by increasing the amount of disk space is still being pursued, but is encountering technical difficulties. Sixteen ITEL 7330 disk drives and two ITEL 7830 disk controllers were hooked up to the 9020 jobshop computers. Significant problems in achieving compatibility with the IBM equipment have been experienced. At this time, the disks are being utilized though problems remain.

### 2.5.3 Future Jobshop Planning

The problems and limitations of the current NAFEC Jobshop require immediate attention so that adequate support to near and long-term users can be provided. The need to upgrade the facility has been recognized by FAA NAFEC and a comprehensive plan for modernization has been developed. The following sections describe the basic NAFEC plan and present a discussion of additional contingency plans which may be needed to hedge against possible uncertainties in the enhancement schedule and to ensure a smooth transition to the new facility.

#### 2.5.3.1 NAFEC Plan for Jobshop Replacement

The NAFEC plan to enhance the jobshop operation provides for replacement of the 9020C computer with another main-frame computer which is to be an IBM 370/168 or equivalent. The objective is to procure a computer which is compatible with the 9020 so that relatively little will be necessary to convert current jobshop software to run on the new system. The enhancement plan provides for a multi-year development. The initial system will include capabilities to process basic OS/MVT, OS/PCP and NOSS jobs. The system will offer improved capabilities such as interactive computing through remote terminals and popular languages such as PL/I and GPSS. Approximately two years after installation, the system will be converted to operate under MVS. A mass storage capability will be procured and the facility will be developed to support such capabilities as the Maintenance Automated Reporting System (MARS) and direct interfaces with operational ATC facilities. A new Print Station will be installed to improve the generation of listings and documents. The probable life span of the new jobshop computer is to be about 5 years at which time it is expected that a new system will be procured.

An Agency Procurement Request (APR) has been prepared, and--at the time of this writing--is being processed through FAA channels. The APR calls for authorization of an intra-government transfer of a 370/168 computer or equivalent with a 4 million byte memory. The APR is supported by a comprehensive feasibility study which presents the analysis of need and cost benefits to be derived from the new system.

#### 2.5.3.2 Contingency Planning

The NAFEC Jobshop enhancement plan appears to be progressing toward approval and it is possible that authorization to proceed will be granted in early 1980. If so, delivery of the new computer system could occur during 1980 and the new jobshop could be operational by the end of the year. However, at this time, there is no official indication of when the approval might be granted. There is a likelihood that the government review and approval process will be extended, thereby delaying the schedule for upgrading the facility. It is important to consider the impact of any delay in the upgrading of the jobshop beyond CY1980. The following describes two scenarios in which it is assumed that the jobshop computer replacement will be delayed for a moderate (1 year) period or a longer period respectively. The impact on operations in each case and possible contingency plans that might be formulated to soften the impact are discussed below.

##### 2.5.3.2.1 Contingency Planning for Moderate Delay in Upgrading

Under this scenario, it is assumed that the replacement of the current jobshop computer will be approved, but availability will be delayed until CY1981. Some contingency planning will be necessary to provide interim measures in the jobshop so that an acceptable level of support to users can be provided. This scenario assumes that from now until the new system is available, the demand for jobshop resources will exceed capacity. A large backlog of jobs will become a common occurrence, some users will have to wait several days for their outputs and some ATC development activities will be affected causing schedule slippages.

The scenario, of course, would present a problem and must be avoided. Planning is necessary to consider viable alternatives to provide supplemental capabilities during the period before the new system is available. Two considerations are:

1. Extend the jobshop hours to 24 hours per day, 7 days per week.
2. Subscribe to time-share service on a 370/168 computer (or equivalent).

Extension of the jobshop operation to seven days per week would increase the capacity by 40%; however, the personnel costs will be high and staffing problems will occur. Also, since no new capabilities would be offered, considerable use of "hands-on" time in the 9020 laboratories and use of the 9020E for batch work would continue. The effect would be a greater impact on development projects requiring the laboratories for T&E.

The use of a 370/168 (or equivalent) time-share service may offer significant benefits. In this mode, jobshop users would have the capability to access a remote computer through computer terminals (possibly located in the programmer's office). The service could be arranged with another government agency having an acceptable computer or bought from one of many commercial service bureaus providing time-share services. To make this option available in a timely and economically-feasible manner, the system should be limited to support basic types of jobs run in the jobshop. With minimal work, the following kinds of jobs could be processed in the time-share mode:

- . OS/360 jobs, for example: JOVIAL compilations  
BAL assemblies  
DART jobs
- . NOSS jobs
- . Analytical support jobs, for example: mathematical and statistical calculations, simulations (e.g., GPSS).

The costs involved in such a remote computer time-share arrangement are:

(1) Computer Charges

Typically, the charge for time-share computer services is primarily a function of the amount of computer time used, main memory requirements, and the utilization of peripheral devices (e.g., tapes, disks, EAM). As a rule of thumb, an average charge of \$50-100 per terminal connect hour can be assumed. If NAFEC usage initially is estimated at five connect hours per day, the approximate cost per month would be: \$5,000-10,000.

(2) Terminals

No extra cost, since the same terminals will be needed to access a NAFEC owned 370/168.

(3) Telephone

Telephone charges would be relatively small. The computer could either be accessed through FTS, or a foreign exchange service could be arranged through the telephone company.

(4) Software Development

No extra cost, since the same software development will be required for a NAFEC-owned 370/168.

(5) User Training

No extra cost, since such training will be required for a NAFEC-owned 370/168.

The remote time-share computer capability will offer several important benefits to NAFEC and tenant organization users. These benefits are:

(1) Availability of Extra Computer Power if and When Needed

The remote computer will supplement the existing jobshop capability should the workload exceed the jobshop capacity. Situations where long turnaround times may develop can be anticipated and quickly corrected by off-loading to the remote computer.

(2) Interactive Computing

The programmer can quickly and effectively compile, assemble, and execute programs interactively at a single terminal session. At present, a single JOVIAL compilation may require several hours at best, and frequently the job is not returned to the programmer until the next day. With the remote computer, it usually takes only a few minutes to obtain--right on the terminal--a list of the compiler diagnostics. Errors, if any, can be corrected immediately on the terminal, and resubmitted for compilation. Thus, the proposed time-share arrangement has the potential to markedly increase the programmer's productivity.

(3) Smooth Transition to a NAFEC-Owned 370/168

The remote computer will provide a facility whereby potential software problems related to transition from the 9020 to the 370 can be detected and ironed out as early as possible. In addition, user training and orientation to the new interactive mode of operation will be more effective by providing the users more time to get familiar with the new capability.

The single potential problem associated with the use of a remote computer as described above, would be the logistics of the operation. Tapes, disks, and computer printouts will have to be shipped between NAFEC and the remote site. Consequently, a fast courier service would be required on a regular basis. An alternate approach, although more costly, would be to provide a high-speed data communications channel between NAFEC and the remote computer. Note, however, that this problem does not apply to jobs not requiring high volumes of data (e.g., JOVIAL compilations, BAL assemblies, and executions of programs involving small amounts of input and output data). It is expected that the primary application of a remote computer, during the initial phase of its use, would be for JOVIAL compilation and BAL assemblies, and would normally not require frequent shipments of tapes or disks.

#### 2.5.3.2.2 Contingency Planning for Long Delay in Upgrading

The possibility that the replacement of the jobshop may not take place before 1982 cannot be discounted. Should this be the case, it is highly likely that the jobshop will not be able to meet the demand, thereby, resulting in a significantly negative impact on NAS maintenance and development activities. While the availability of a remote computer, as proposed in the previous section, will certainly provide some relief, additional measures may be required at that time, such as: (1) conversion to a 24 hour, 7 days per week operation, (2) installation of high speed data lines and devices to support communications between NAFEC and the remote computer and/or (3) use of the NAFEC Honeywell 66/60 computer (see Section 2.5.4.2).

#### 2.5.4 Additional Considerations for Future Jobshop Planning

This section discusses several issues with regard to future enhancements of the NAFEC jobshop facilities. The following questions are addressed:

1. Should, or could, the existing jobshop be upgraded by installing some add-on hardware devices (e.g., peripherals, main memory)?
2. Should, or could, NAFEC's Honeywell 66/60 computer be used to handle a portion of the jobshop workload? -
3. What will be the impact of FAA's 9020 replacement program on future jobshop planning?

In addition, the following discussion includes some findings and recommended improvements in the area of software test bed development for NAS support.

#### 2.5.4.1 Upgrading of Current Jobshop

An earlier section (2.5.2.6) discussed several activities over the last several years to upgrade the capabilities of the jobshop. These efforts have enhanced the general capabilities; however, there are varied opinions regarding whether or not additional resources should be allocated to improve the current jobshop. The prevailing opinion is that the 9020C has reached its capacity and that no further enhancements are technically or economically practical. In view of NAFEC's commitment to acquire a 370/168 computer, it does not appear that further expenditures in hardware or software enhancements for the 9020C will be cost-effective. However, since the time of such installation is still uncertain, efforts should continue to increase the efficiency and availability of the OS jobshop, in general, within the existing NAFEC resources.

#### 2.5.4.2 The Honeywell 66/60 System

The Honeywell 66/60 system at NAFEC is a large-scale computer with advanced time-share capabilities, data management facilities, and extensive applications software. The 66/60 is, in many respects, highly superior to the 9020C jobshop computer. The 66/60 is used at NAFEC as a general purpose data processing computer facility. Because its instruction repertoire and software are incompatible with those of the 9020, jobs directly related to the NAS en route system remain confined to the 9020 computer complex, while other jobs generally are more efficiently executed on the 66/60. Another reason why the 66/60 is not used for NAS software work is the reluctance of users who are familiar with 9020 language, operating system, and procedures, to convert to the totally new and unfamiliar environment of the 66/60.

Although the incompatibilities between the 9020 and the 66/60 are certainly a problem, it is possible that some of the jobshop workload could be diverted to the 66/60. Therefore, if a situation should develop which will significantly delay the jobshop computer replacement, an investigation should be performed to determine if the 66/60 can be made available and which jobs could be considered for processing on the 66/60. Some candidate jobs for the 66/60 are:

- . Data reduction of SAR tapes. Thus, some of the most popular and time-consuming DART processes could be off-loaded onto the 66/60.
- . Updating NAS master files.

- . A cross-compiler for the 9020/JOVIAL could be developed on the 66/60. This will provide interactive compilations of JOVIAL. The users will be able to compile JOVIAL programs in a single terminal session, rather than through several job submissions as done frequently today.
- . The extensive data communications capabilities of the 66/60 could be used to support communications with the field sites.

#### 2.5.4.3 Impact of the 9020 Replacement Program

The 9020 replacement program will probably have a significant effect on NAFEC's data processing requirements. Future planning for expansion of the NAFEC jobshop should be coordinated with the 9020 replacement program to insure that the needs of the replacement program can be accommodated within the jobshop capabilities. At this time, many uncertainties existing with regard to the technical characteristics of the 9020 replacement, and its time-frame, preclude its inclusion as a significant factor in any long-term plans for jobshop expansion.

As the status of the jobshop expansion effort changes, periodic reviews should be made of the 9020 replacement program to insure that as much as possible of the 9020 replacement needs for off-line functions can be supported by the future jobshop capabilities.

#### 2.5.4.4 Software Test Tools

AAT-550 at NAFEC is currently in the process of developing enhanced software tools for the en route and terminal systems. These tools will augment the conventional test facilities which were developed several years ago to support ATC development and testing efforts. A survey conducted recently indicated that the new test tools are estimated to increase the load of the 9020 jobshop by 10%. At the same time, it is expected that NAS en route system testing in the SSF will be decreased by 20%.

Development of adequate test tools can be beneficial in reducing the time and resources needed for testing. Today, many tests at NAFEC are run on dedicated time and require a complete 9020 system, even if only a small portion of the system (e.g., a single software module) is actually tested. There is also a high overhead cost in set-up time and job configuration and reconfiguration time. Due to limitations of the testing capabilities at NAFEC, many system problems encountered at the sites cannot be resolved at the SSF, requiring that a technician travel to the site.

Presently, each user at NAFEC either uses the existing test tools, or develops his own special purpose tools for his particular application. NAFEC's Data Engineering and Development Division (ANA-700), responsible for managing the 9020 computer complex, has been primarily concerned with operating the facilities and providing the routine services required by the user. NAFEC should take a more active role in the development of general purpose test tools, especially for the NAS en route system. Efforts to enhance the test tools, such as currently undertaken by AAT-550, need to be coordinated by NAFEC to insure that all NAFEC users will benefit from the new capabilities.

## 2.6 NAFEC Communication Switching System

On April 18, 1979, a contract was awarded to the AMECOM Division of Litton Industries to install and test an electronic communication switching system in the ATC laboratories at NAFEC. The NAFEC Communications Switching System (NCSS) is scheduled to be deployed in early 1981. The system will connect all controller positions at NAFEC, interface with remote facilities (e.g., the DABS sites at Elwood and Clementon), link controllers with aircraft via radio, and provide access to the Federal Telephone System (FTS) or other telephone network. Table 2-2 delineates the equipment components of the NCSS.

Future expansion is expected to take place in connection with the development of the Voice Switching and Control System (VSCS) which will be implemented nationwide (see Section 4.1.5). NCSS makes extensive use of microprocessor-controlled switching and distribution for all of the communications channels. Various predefined configurations of controller position assignments will be stored on computer tapes, and reconfigurations will be quickly accomplished at a system monitoring position equipped with a CRT and a keyboard entry device. The system will also provide a data recording function to support analyses of human factors and other communications-related measures.

### 2.6.1 The Impact of NCSS on the ATC Test Bed

The NCSS, to be installed in the new T&A complex, will replace the current BELL 300 system, and will handle the communications in the ESSF, ATCSF, TATF, TSSF and remote facilities.

The NCSS is expected to greatly improve the reliability of inter and intra-facility voice communications and the flexibility of reconfiguring the system according to test requirements. Prior to

TABLE 2-2

NCSS EQUIPMENT

(From "AMECOM Switching System", July 10, 1979, Litton Systems Incorporated).

BASELINE SYSTEM

- . 100 Positions
- . 45 TELCO Lines
- . 15 Radio Channels

EXPANDED SYSTEM

- . 250 Positions
- . 70 TELCO Lines
- . 25 Radio Channels

Planned Laboratory Installations:

BASELINE SYSTEM

ATCSF	13 Positions
ESSF	49 Positions
TATF	17 Positions
TSSF	15 Positions
AEROSAT	6 Positions

EXPANDED SYSTEM

40 Positions
110 Positions
40 Positions
50 Positions
10 Positions

acceptance of the NCSS, an interim voice communications system will be installed to fulfill the need for voice communications between the ATCSF, ESSF, TATF, and remote sites.

#### 2.6.2 NCSS/NLSSS Coordination

The NAFEC Laboratory Signal Switching System, described in Section 2.7, will serve as the central switching and distribution point for surveillance data communications between the ESSF, TATF, TSSF, ATCSF, and remote surveillance sites, including the DABS sensors. The NLSSS will be used to establish configurations for data communications between the various facilities. The data communications function provided by the NLSSS will serve the same test configuration simultaneously with the voice communications function provided by the NCSS. The configuration control and the coordination between these systems will be an important task. As part of future planning for the NCSS and NLSSS facilities, there will be a need to insure that the control consoles for these and other system interface switches, as discussed in paragraph 2.1.2, are controlled by a qualified staff of trained technicians organized in a single central switching control facility.

#### 2.7 NAFEC Laboratory Signal Switching System

The NLSSS is to be installed in the new T&A complex in late 1980. The equipment will provide integrated data switching and distribution with remote control capability. The system will contain signal monitoring features, fault alarms, and a microprocessor control of the switch configurations. The system is designed to be capable of modular expansion to accommodate increases in the number of interfaces which the ATC test bed might include.

Figure 2-16 contains an overall block diagram of the NLSSS. As indicated, the system includes primary and secondary distribution systems. The primary system receives analog and digitized radar, beacon, and interfacility ATC data from remote and local live and simulated sources. The primary system provides input/output switching and distribution for the local signal processors and for the recording and reproducing equipment. The primary system interfaces directly with the ESSF equipment, thus providing the ESSF with its input signals. The primary system also provides signals directly to equipment located in the FSS laboratory, general laboratories, CRT test facility, and indirectly to equipment within the TSSF and TATF through the NLSSS secondary distribution systems. Each distribution system will be equipped with its own remote switch module which is used to establish the signal switching patterns applicable to the laboratories which it serves.

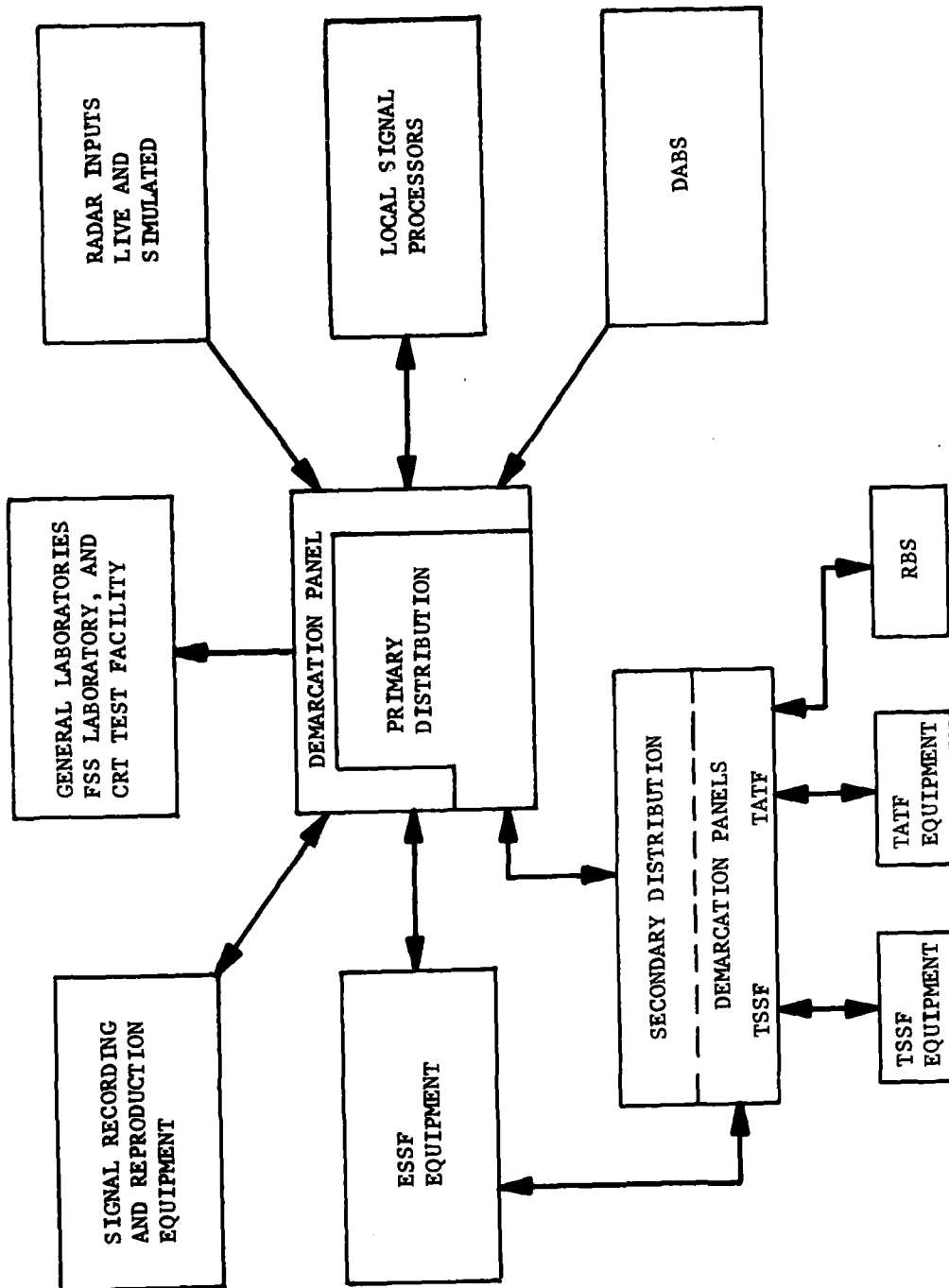

FIGURE 2-16 NLSS OPERATIONAL ENVIRONMENT

The NLSSS will be capable of switching and distributing demodulated, digital data, that is either input to or received from MODEM's. The maximum bit rate is specified to be 9600 b/s.

The analog data which is handled by the NLSSS will include radar/beacon surveillance data, normal video, MTI video, map video, beacon triggers, beacon video, azimuth change pulses and azimuth reference pulses.

The primary switching system will be located on the second floor of the new T&A complex; the secondary system will be located on the third floor. The NLSSS will replace much of the patch and plug hardware which currently exists in the en route and terminal laboratories, as discussed in Sections 2.1 and 2.2. Remote control of the primary and secondary systems at one location will be feasible.

#### 2.7.1 The Impact of the NLSSS on the ATC Test Bed

The NLSSS will provide an upgraded capability for switching and distributing signals among the various laboratories and facilities within the NAFEC ATC test bed. The availability of a centralized and specialized capability will enable the laboratory facility personnel to develop enhanced capabilities to establish interfaces, verify interfaces and quickly determine the source of problems in a multi-system test environment.

The unique nature of the NLSSS requires that special procedures be put into practice for the test bed to realize the maximum benefit which the NLSSS might provide. These procedures should be developed in consideration of the following:

- . All signals which are passed between the various laboratories must be controlled by the NLSSS to gain maximum benefits.
- . The NLSSS will have no Fail-Soft capability, as currently planned. An NLSSS failure could interfere with a multi-system test, rendering the test worthless. Care must be taken that a failure of one interface, or subset of interface channels, does not cause trial and error troubleshooting which could interfere with remaining interfaces. The operation of the NLSSS must be strictly controlled, and established procedures strictly adhered to.

- . The NLSSS will control interfaces in various test bed configurations which also involve communications switching via the NCSS (see Section 2.6) and other interface switching through other capabilities. The controls for all of these switching systems should be located in one central facility, under the control of a designated staff.
  
- . The NLSSS will provide the capability to distribute signals to all laboratories and systems in the NAFEC ATC test bed, via the NLSSS configuration control hardware. The versatility thus provided should be developed further through a study to identify other data channels which could be controlled through the system. An example is the time-of-day signal (see Section 2.1.8.3) which has been recommended to enhance the NAFEC test environment. Other signals, e.g., triggers, start/stop indicators, or alarm signals, might be generated and controlled via the NLSSS in the central switching facility.

### 3. CURRENT USERS OF NAFEC ATC FACILITIES

A great variety of ATC projects are under way at NAFEC, ranging from the testing and maintenance of the current NAS en route and ARTS III systems to the development and analysis of long-term enhancements and future concepts of ATC functions. As stated in FAA directive 1100.5A, "FAA Organization - Field", NAFEC's mission is as follows:

- a. Operate and administer a national test center providing laboratories, facilities, skills and services responsive to the research, development, and implementation programs of FAA.
- b. Systematically apply scientific knowledge to develop, test, and evaluate new or substantially improved equipment, systems, materials, processes, techniques, and procedures.
- c. Perform or participate in research, engineering, and development to provide new or improved techniques or methodologies for airport designs, layouts, construction, and operations, and for improved or new aircraft safety systems and devices, improved crashworthiness designs and techniques, improved or new aircraft control systems, and support of the agency's environmental development programs.
- d. Perform other program and support functions as assigned by the Administrator.

Consistent with its mission, NAFEC supports many FAA as well as other government organizations who use NAFEC's capabilities and facilities to accomplish their project requirements. In addition to facility utilization by NAFEC personnel, other tenant organizations located at NAFEC and their subcontractors are heavy users of the facilities.

As part of the NAFEC Facilities Planning study, several discussions were held with these users in an effort to gather data on current and forecasted activities and needs for NAFEC resources. In addition, through the use of informal questionnaire forms, the users were requested to provide information on the adequacy and the responsiveness of NAFEC ATC support facilities, and to identify areas where potential improvements can be made. Several recommendations for improvements, as well as problem areas discussed in this report, are based on information provided by NAFEC users. The major tenant organizations at NAFEC are: AAT-550, AAF-360, and ARD-140. These are described below.

AAT-550, the National Automation Support Branch, located at NAFEC, is an arm of the Air Traffic Control Automation Division (AAT-500). AAT-500 "is responsible for air traffic control operational software production and maintenance and maintains the operational air traffic control software computer programs" (excerpt from FAA Order 1100.2, "FAA Organization FAA Headquarters", para. 3324). AAT-550 maintains the operational version of terminal and en route systems used in the field, i.e., ARTS II, ARTS III, NY TRACON, EARTS, NAS En Route Stage A, E-MSAW, and others. In addition, AAT-550 is involved in the development of enhanced ATC systems, i.e., ARTS IIIA, ETABS, DARC, and others. AAT-550 is a heavy user of the ESSF, TSSF and the OS Jobshop. Discussions with AAT-550 personnel indicate that the combination of the on-going activities plus the new ATC enhancements are expected to continue to place a heavy demand on NAFEC's facilities usage.

AAF-360, the Automation Engineering Support Branch, located at NAFEC, is an arm of the Radar/Automation Engineering Division (AAF-300). AAF-300 "is the principal element of the Service (Airway Facilities) for the radar/automation engineering aspects of the airway facilities program, including en route and terminal radar and automation facilities, weather radar, flight service station automation program, airport surface detection systems, secondary radar systems, and en route and terminal remote radar monitoring systems" (excerpt from FAA directive 1100.2, "FAA organization - FAA Headquarters", para. 3912). AAF-360, together with its contractors, are major users of the ESSF, TSSF and Jobshop facilities.

ARD-140, the Development Programming Branch, located at NAFEC is an arm of ARD-100, the ATC Automation Division. ARD-100 "is the principal element of the service (System Research and Development Service) with respect to requests for research and development effort, systems requirements, and monitoring and exploiting advances in the state-of-the-art in the areas of en route and terminal system automation, central flow control automation, oceanic traffic control, data display, procedures, airport surface traffic control, and controller training activities, and the implementation of assigned automation programs" (FAA directive 1100.2, "FAA Organization - FAA Headquarters", Para. 4410). ARD-140, a branch of the division, "develops and monitors the development of software (computer programs) for automation of en route, terminal, oceanic and central flow control, and conducts system analyses and studies of new computer program capabilities for the ATC automation systems. It also provides technical direction to software contractors and monitors testing to ensure conformance to computer program functional specifications" (FAA directive 1100.2). ARD-140, and its contractors, are heavy users of the ESSF, TATF, and Jobshop facilities.

In addition to the above NAFEC-located users, NAFEC ATC facilities are used to support many ATC-related projects assigned by FAA and other government organizations. In particular, many R&D projects, under development by SRDS, normally are heavily dependent on the use of NAFEC facilities for development, testing and evaluation.

#### 4. FUTURE ATC PROGRAMS AT NAFEC (1980-1989)

During the years 1980-1989, the ATC system will undergo a major evolution with the development and implementation of several advanced ATC automation capabilities. NAFEC will play an important role in the development of these advanced capabilities and in the subsequent activities to implement and maintain them in the field. The many projects with their heavy demands for support will require significant advanced planning to ensure that NAFEC will be capable of providing the services required.

Throughout the 1980-1989 period, there will be a combination of ATC programs at NAFEC in various stages of development and implementation. Many of the new development programs will include new hardware elements which will need to be integrated with the current NAFEC facilities. Some of the new hardware systems will arrive at NAFEC as engineering models and be replaced by production systems after field implementation. Many programs will involve the development of new software functions basically within the framework of the existing hardware systems and will require facilities for software production and testing, and operational evaluation.

Following is a list of the programs expected to have the most impact on NAFEC facilities and support resources:

- Discrete Address Beacon System (DABS)
- Electronic Tabular Display System (ETABS)
- Terminal Information Processing System (TIPS)
- Automated Flight Service Station (AFSS)
- Voice Switching and Control System (VSCS)
- Control Sector Redesign
- Automated En Route Air Traffic Control (AERA)
- ATC Computer Replacement

Figure 4-1 indicates the basic schedules for these programs and some other programs expected to have less impact on NAFEC facilities, but which will add to overall support service requirements. The schedules show that the years 1980 to 1985 will involve heavy R&D activity to define the implementation design requirements for many of the new systems to be installed in the field in the latter part of the decade. This activity will overlap the continuing work of the operating services to maintain the current ATC systems.

FIGURE 4-1 MAJOR PROGRAMS IMPACTING NAFEC TESTING & EVALUATION FACILITIES

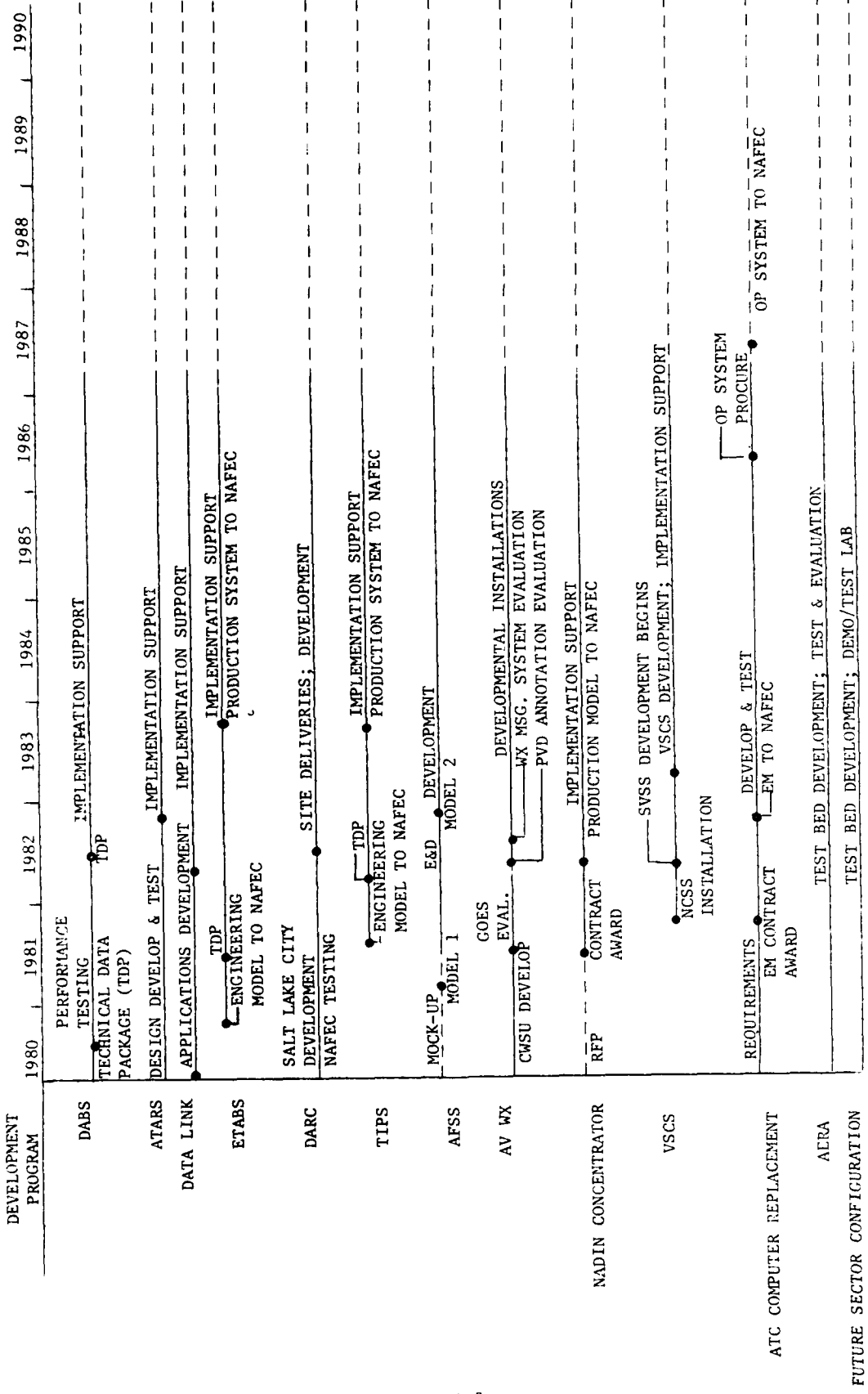

#### 4.1 Description of Major Future Programs

The following sections describe the major future programs at NAFEC with attention to the characteristics of the new systems which will impact facilities and the requirements which will necessitate advanced planning for support services or system integration at NAFEC.

##### 4.1.1 Discrete Address Beacon System (DABS)

The DABS program has been under way at NAFEC since 1977. A DABS computer facility is currently established which communicates with three engineering model sensors located at Elwood, NJ; Clementon, NJ; and locally at NAFEC. The DABS facility includes communications and interface provisions to allow the sensors to interface with the ESSF, TATF and ATCSF for system testing. The ATCSF includes capabilities to simulate DABS surveillance and communications functions and is being utilized to support both the technical and operational tests of DABS system design concepts. The DABS program activities at this time involve development, test and evaluation work on the DABS sensors and system testing using both the en route and terminal ATC system configurations.

ATARS and data link applications development work is going on in parallel with the DABS surveillance activities. Over the period 1980-1982, comprehensive testing of DABS surveillance, ATARS and data link functions will be conducted at NAFEC and the DABS program will be a major user of ESSF, TATF and ATCSF time for software development and testing.

Over the longer term (i.e., post 1985), DABS activity will shift toward implementation support. It is expected that production systems will be procured beginning in the 1983-85 period. The NAFEC engineering models may be replaced by one or more production versions for integration with the NAFEC ATC system configurations.

During the interim period (1982-1985), the DABS work at NAFEC will most likely continue at a high level. Functional enhancements may be developed and tested and procedural aspects related to the DABS transition into field operations will be investigated. Therefore, there will be a continuing demand by the DABS program for NAFEC support facilities through much of the next decade.

#### 4.1.2 Electronic Tabular Display Subsystem (ETABS)

The ETABS development program is intended to introduce advanced concepts for data display and controller-computer interaction to the ATC system. As described earlier (Section 2.1.3.2), an ETABS engineering model will be installed at NAFEC in 1980. The system will be integrated into the ESSF with interfaces with the 9020s and equipment at several D-controller consoles located in the display laboratory. The program will involve significant software development in both the 9020s and internal to ETABS and will be a major user of the ESSF and the NAS Jobshop. Also, a major part of the ETABS development will be a comprehensive operational evaluation of the ETABS capabilities and concepts. Here again the program will require large amounts of time in the ESSF using the full system configuration and probably some support from the ATCSF.

The requirements of the ETABS project will impact NAFEC in several ways. Since six of the eleven available sector positions in the "D-Lab" will be modified with the ETABS display and data entry equipment, other programs requiring standard NAS sector configurations may be restricted in the display laboratory. Also, ETABS will require the 9020D in all system testing because of the need to operate with contiguous PVD's (see Section 2.1.8.6). This requirement will impose scheduling restrictions and limit the flexibility in satisfying other facility users.

Since ETABS will require large amounts of time in the ESSF and be a major user of the jobshop, there will be limitations on the time available to the many programs and possible delays in test schedules and turn-around time in the jobshop.

The longer term impact of ETABS on NAFEC is uncertain. Following the R&D activities, a field configuration will be procured and implemented. Most likely, a field version of ETABS will be delivered to NAFEC for integration into the ESSF and use in field support. The uncertainties affecting NAFEC lie in the characteristics of the field system configuration versus the engineering model and the number of sector positions that would be installed at NAFEC. It is possible that ETABS will become associated with the ATC computer replacement program and its functions integrated in the data processing architecture of the replacement system. However, it appears more likely that an interim version of ETABS will go to the field before the ATC replacement system is available. The result is that NAFEC must devise the flexibility to configure ETABS into a configuration controlled system in the ESSF and also possibly provide a connection to the ATC computer replacement system when it arrives for development.

#### 4.1.3 Terminal Information Processing System (TIPS)

A TIPS engineering model is scheduled for delivery to NAFEC in the fall of 1980. The system includes both TRACON and tower displays and processors. The system will interface with the 9020s in the ESSF and the ARTS III IOP's in the TATF. The program will involve several months of test and evaluation of the hardware and software functions and a period of operational evaluation in support of field site testing of a second TIPS model.

TIPS should not pose a significant space problem as the equipment is not large. Therefore, the most significant impact of the program at NAFEC will be its requirements for test and software support. The program will be a major user of the TATF and ESSF for testing during the late 1980 and early 1981 period. Software development work and testing of the TIPS interfaces with the en route and terminal computers will be significant. Therefore, relatively heavy requirements for NAFEC Jobshop support and scheduling of the ESSF and TATF can be expected.

#### 4.1.4 Automated Flight Service Station (AFSS)

The AFSS program involves a number of data communications systems, display systems and interfaces with remote facilities (Appendix F contains overall system block diagrams). Section 2.3 discusses the FSS laboratory planned for the new T&A complex. The AFSS development is expected to become a major NAFEC program with the most significant support requirement being in the area of hardware maintenance and operational support. The display and microprocessor hardware will consist of state-of-the-art devices and assemblies. Laboratory accommodations to support maintenance and storage needs for read only memories, various disc drives, display devices, and spare parts must be considered when developing long-term plans for the facility.

#### 4.1.5 Voice Switching and Control System (VSCS)

The VSCS program is in an early stage of planning. The basic objective of the program is to develop new interphone and radio communications systems for En Route Centers, TRACONs, Towers and Flight Service Stations. The plan under consideration calls for NAFEC to play a prominent role in the T&E of several prototypes leading to Technical Data Packages (TDP) for a production version. The VSCS program plan consists of a number of elements. The new

NAFEC Communications Switching System (NCSS) would be used as a basic test bed to develop the En Route Center communications system. The Small Voice Switching System (SVSS) subprogram, will provide a prototype system at NAFEC to be used in developing the TDP for procurement of small tower systems. A modified version of the Dallas/Fort Worth Terminal Communications Switching System (TCSS) would be procured for test and evaluation at NAFEC leading to specifications for a large TRACON and small TRACON communications system. A Flight Service Station prototype will be procured based on the Leesburg FSS system and evaluated at NAFEC.

The VSCS program at NAFEC will extend from 1980 to well into the decade. The program has the potential to be very significant in terms of equipment to be installed at NAFEC and test and evaluation activities. Much of the equipment would be integrated with the NAFEC system support facilities. Test work would include both engineering and operational testing.

The potential magnitude of this program and the possible impact on NAFEC facilities justify a close coordination interface between NAFEC planners and the SRDS program managers.

#### 4.1.6 Control Sector Redesign

Control Sector Redesign is a generic program encompassing the concepts embodied in a number of future ATC system programs. Changes in the controller-computer interface and changes in sector layouts to accommodate new sector manning considerations and controller responsibilities are included. Control Sector Redesign will support the ETABS, DABS data link and AERA programs through specific experimentation and development work related to the aspects of those programs bearing on human factors, console design, and device characteristics.

It is expected that NAFEC will have responsibilities to conduct projects designed to develop and evaluate alternative sector configurations within the context of the specific R&D programs. These responsibilities will generate requirements for facilities and support resources.

In order to support the type of work entailed in control sector redesign, NAFEC will require a relatively small scale but well provisioned laboratory for static and dynamic experimentation. The existing Controller-Computer Interface Laboratory (CCIL) at NAFEC might serve as the basis for developing such a facility, or the enhancement of the ATCSF might include provisions for such a capability. To be effective, the NAFEC facility must be responsive and representative of the real world operational environment.

As the future ATC systems evolve, more and more attention will be placed on human factors issues. There will be an increasing justification for an effective facility at NAFEC to support work in these areas. The facility should be independent of the primary system support facilities and capable of supporting both terminal and en route testing and evaluation efforts.

#### 4.1.7 Automated En Route Air Traffic Control (AERA)

The AERA program involves activities to develop advanced air traffic control automation capabilities. The basic concept of AERA is to automate the routine aspects of IFR en route clearance planning and issuance. The program is currently in the stages of algorithm development and feasibility demonstration using small-scale simulation facilities located at The MITRE Corporation in McLean, Virginia. The program has high visibility and is planned to move into the next stage which will include the development of an "AERA Test Bed" to support operational type testing. Figure 4-2 indicates the basic configuration of the AERA test bed. The system will include an interface with the NAS CCC and several separate processors to perform the AERA functions. The initial test bed will include at least two control team positions, a supervisory console and a test conductor's console. Embodied in the AERA concepts are major revisions in the manner and type of displays and controller-computer interaction capabilities at the sector positions. Figure 4-3 illustrates the anticipated sector layout to support AERA development and human factors experimentation.

The AERA development schedule provides for development of the test bed in a portable configuration by mid-1981. The plan is then to take the test bed either to an operational center or to NAFEC, and conduct operational tests over approximately the mid-1981 to early 1982 time period.

If the decision is made to bring the AERA test bed to NAFEC, problems will include space planning and establishment of a 9020 interface with the AERA test bed which will satisfy configuration control restrictions in the ESSF. Integration of the test bed will further complicate the ESSF and its scheduling to support all users. Also, the program will involve a comprehensive operational evaluation which will require the scheduling of large amounts of time in the ESSF and the ATCSF. Therefore, the program will be a major competitor to other R&D and operating service projects.

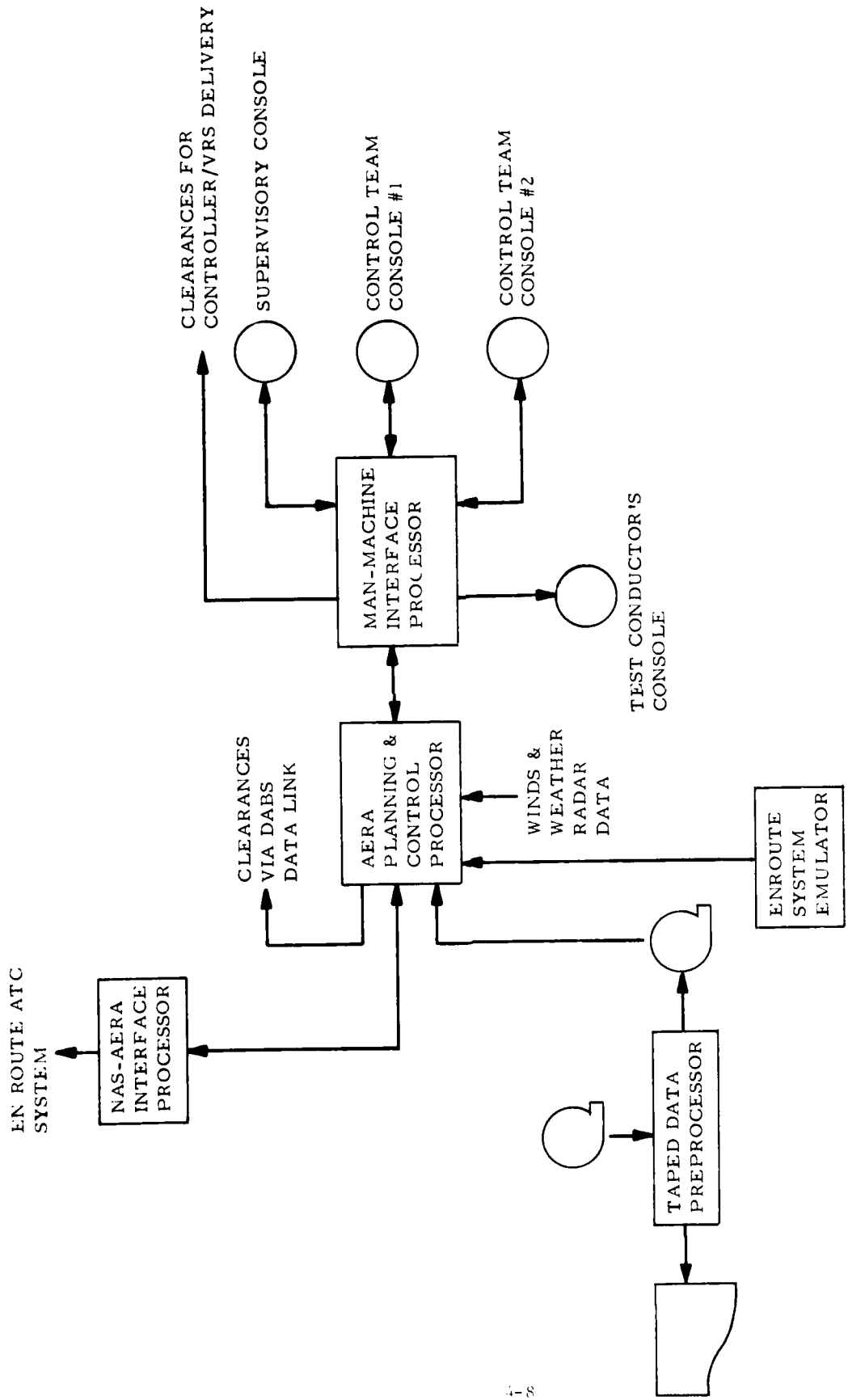

FIGURE 4-2 AERA TEST BED

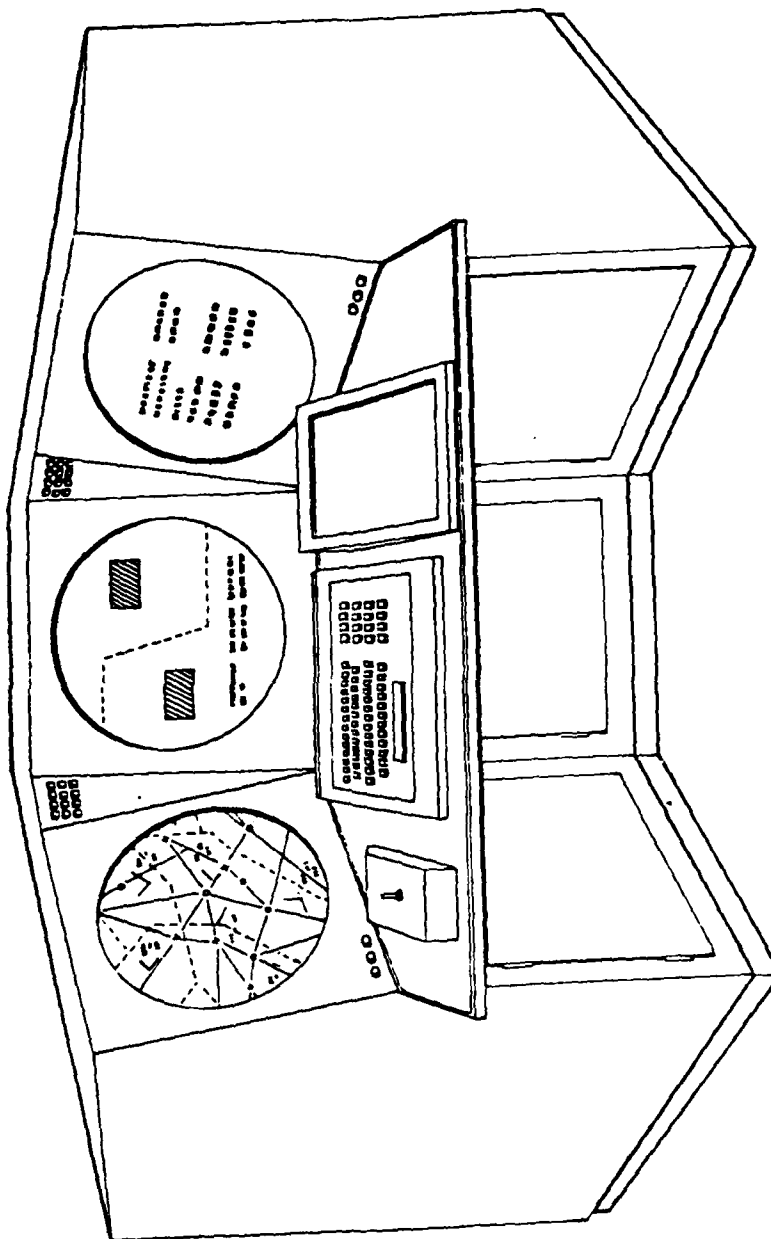

FIGURE 4-3  
 DISPLAY AND DATA ENTRY EQUIPMENT FOR AERA DEVELOPMENT  
 AND HUMAN FACTORS EXPERIMENTATION

#### 4.1.8 ATC Computer Replacement

The ATC Computer Replacement Program has the potential to have the most significant impact on NAFEC during the 1980's. The uncertainties regarding the replacement characteristics at this time prohibit a firm analysis of what the impact will be in terms of space requirements, laboratory configurations or software support requirements. The scope of the program is to include the en route Central Computer Complex, the display channel equipments and the radar controller displays. The program is also to consider replacement of the ARTS III terminal system equipment. The program has many alternatives ranging from piece-meal replacement of system elements to a wholesale replacement of all affected subsystems.

The magnitudes of the hardware and software development tasks seem to weight against any plan which does not use NAFEC facilities in a significant way. Also, the requirements to test and evaluate the operational characteristics of the new system would seem to support the need to use NAFEC during the development stage or at least during the pre-deployment stage. Therefore, it appears that NAFEC must have a significant role in the replacement program.

The alternative replacement strategies will pose significant problems for NAFEC. Piece-meal implementation will require the maintenance of several different software versions and will place a tremendous load on NAFEC software support facilities during the period. A wholesale replacement will require significant space and support resources.

Clearly the replacement program deserves close attention by NAFEC planners. As the development plan evolves, the impact on NAFEC must be identified. The requirements of the program may generate the need for significant changes or additions to the NAFEC facilities which may have long lead times.

#### 4.2 Impact of Future Programs on NAFEC

As indicated above, many new ATC development systems representing the elements of the future ATC system will begin to arrive at NAFEC for test and evaluation in 1980. It is clear that there will be a significant rise in R&D activity and in the demand for NAFEC support facilities which will be sustained for several years into the 1980's. The T&E and software development requirements of these programs will tax the NAFEC resources and it will be increasingly important to improve the efficiency, productivity and capabilities of these facilities.

Within the context of the current NAFEC facilities, the following basic problems can be expected over the next several years unless steps are taken to preclude them:

- (1) The ESSF will become increasingly complex as new sub-systems and interfaces are added and problems in configuration control and facility scheduling will arise. Operating service priorities in scheduling the test and support facilities will affect R&D activities to a greater degree.
- (2) The demand for software production and test support from both the operating services and the R&D organizations will outstrip the capacity and capability of the NAS Jobshop.
- (3) New user organizations will find it increasingly difficult to become oriented to facility operations because of configuration control and scheduling restrictions, and complex coordination requirements and operating procedures.
- (4) The large ATC display laboratories will continue to be used to supplement the OS Jobshop resources and to support various projects involving development of functional areas such as related to man-machine interface evaluations which could be better supported by relatively small-scale facilities tailored to this type of T&E.
- (5) Over the longer term, there will be problems with laboratory space crowding and equipment integration as new systems are implemented, such as the ATC computer replacement, display replacement and AERA. Either independent laboratories or a complex arrangement for sharing subsystems will be required.

The types of problems above must be dealt with through decisive action and advanced planning. Near-term steps are required to solve the basic problems of inefficiency and complexity in facility operations and management. A longer term coordination and planning program is required to anticipate and preclude problems with the NAFEC support facilities and services.

#### 4.3 Need for Long-Term Technical Planning

A basic problem at NAFEC in dealing with long-term technical programs is an apparent lack of suitable procedures for planning beyond an annual budget period. Without long-term plans, the NAFEC annual budgets for DT&E facility development are routinely cut in Washington. Long-term planning can serve to provide a stronger position in justifying budget requirements, establish program continuity and direction, cause adequate attention to be given to future program requirements, and provide sufficient lead times in developing support capabilities. A strong need exists for the development of a Master Technical Program Plan which will address all NAFEC ATC programs and projects and reflect work and associated budget and resource requirements for at least five year periods. The Master Plan should contain detailed five year plans for all major E&D programs and general planning for NAFEC facility upgrading and enhancement. The plan should be updated regularly and maintained through an effective coordination interface with FAA headquarters program managers.

#### 4.4 Need for Advanced Technology Programs

The trend toward greater automation in the ATC system is generating interest in applications of advanced technologies which can offer long-term performance and economic benefits. In that the FAA is responsible for specifying the future ATC systems, it is in their best interest to develop a strong technical base of understanding in the new technology areas with potential applications in ATC. In general, it seems that NAFEC should play a primary role in developing the necessary expertise.

An example of the type of work that is appropriate at NAFEC is the Voice Recognition System that has been under experimentation for the last few years. Potentially, voice recognition can offer significant benefits in certain ATC applications. Such experimentation is expediting the time when suitable systems are available for introduction into the ATC systems.

Other promising technology areas are emerging which deserve FAA attention. One such area is fiber optics. A program of experimentation and study of the technology at this time would be useful. A NAFEC program could involve the installation and testing of a fiber optics link for remoting radar data from either the ASR-4 or 5 radars at NAFEC. The program should also include an applications study to consider various other areas in the ATC system where fiber optics might offer benefits.

## 5. CONCLUSIONS AND RECOMMENDATIONS

Conclusions and recommendations are summarized below in the following areas:

- . Laboratory Control and Management
- . Software Support Capabilities
- . ATC Simulation Support Capabilities
- . Long-Term Facility Development

### 5.1 Laboratory Control and Management

#### 5.1.1 Interface Switching and Control

##### Conclusion

The extensive use of manual switching and patching in the inter-system interfaces used in the ESSF and the TATF has resulted in complex, time-consuming and error-prone procedures needed to establish alternative equipment configuration as required to support both development projects and operating service activities (see Sections 2.1.2, 2.1.3 and 2.2.1).

##### Recommendation

A centralized switching and control facility should be established in the T&A Complex. This facility should include capabilities to establish and monitor the major hardware interfaces in the ATC laboratories. Included should be interface switching and configuration controls for the DARC, 9020s, Display Channels, ETABS, DABS, ARTS III IOP, NLSSS, and NCSS (see Sections 2.1.8.2, 2.2.4.1 and 2.6.2). Means for controlling and distributing master time synchronization signals to the test beds should also be included (see Section 2.1.8.3 and Appendix D).

#### 5.1.2 Interfacility Time-Synchronization

##### Conclusion

The current manual method for time-synchronization of interconnected systems is cumbersome, impedes startovers, and results in timing errors which cause data analysis problems (see Section 2.1.5.3).

### Recommendation

A master time-synchronization system should be developed for use by all ATC test facilities. The system would provide automated time-synchronization between several test facilities when jointly used for testing (see Appendix D).

### 5.1.3 Facility Scheduling

#### Conclusion

Scheduling of the ATC test facilities will become increasingly complex with the addition of new development systems, new interfaces, and a multitude of alternate test configurations. Lead time for scheduling will increase, and the efficient scheduling of resources is likely to suffer if manual procedures are continued (see Section 2.1.7).

#### Recommendation

Automated scheduling aids should be developed to support an efficient scheduling of facility resources, permit quick response to changes in system configuration and user priority assignments, and reduce the lead time required for facility scheduling (see Section 2.1.8.5).

### 5.1.4 Facility User Orientation

#### Conclusion

Requirements for user orientation and education will become essential considering the growing complexity of the facilities and the expected addition of new FAA and contractor users over the next several years. Current informal user orientation and on-the-job-training are inappropriate for a modern facility (see Sections 2.1.5 and 2.1.8.4).

#### Recommendation

NAFEC should develop a formal program of orientation and education for users in the capabilities, operations and procedures of the ATC test facilities. The program should include a "User Briefing Center" which would provide users with the basic information needed for efficiently using NAFEC ATC test resources (see Appendix E).

AD-A082 764

MITRE CORP MCLEAN VA METREK DIV F/G 17/7  
NAFEC AIR TRAFFIC CONTROL (ATC) FACILITIES PLANNING: CURRENT CA--ETC(U)  
FEB 80 D J SWEENEY, R A AMATO, H S GABRIELI DOT-FA79NA-6013  
MTR-80N00001 FAA-NA-80-160 NL

UNCLASSIFIED

2 of 2.

AD-A082 764

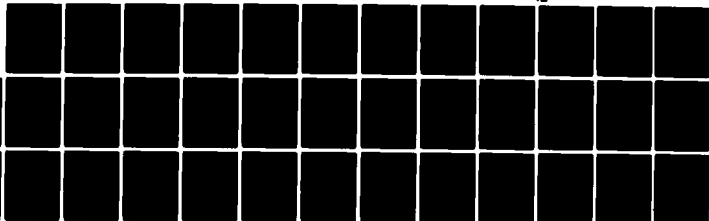

END  
DATE  
FILMED  
5-80  
DTIC

## 5.2 Software Support Capabilities

### 5.2.1 NAS Jobshop Capacity and Capability

#### Conclusion

The existing computing power and software capabilities of the NAS Jobshop are inadequate to meet the requirements of the development and testing activities projected to take place at NAFEC in the early 1980's (see Section 2.5).

#### Recommendation

The enhancement of the NAS Jobshop facilities should be given high priority in NAFEC plans for ATC test facilities. The plans should: (1) insure a reasonable turnaround time for job submissions (optimally, an over-night output should be guaranteed), and (2) provide software facilities, such as: interactive computing, high level languages (e.g., PL/I, APL, GPSS), data base management, mathematical and statistical packages, text editing and other modern software tools.

### 5.2.2 NAS Jobshop Development Plans

#### Conclusion

At the present time, NAFEC is pursuing efforts to obtain government approval and funding for a 370/168 computer (or equivalent) as a replacement of the existing 9020-based jobshop. It is likely that the review and approval process will be subject to delays which could postpone the jobshop replacement to beyond CY1980.

#### Recommendation

A contingency strategy should be formulated to provide sufficient software support if the new computer is not installed within the required timeframe. Several options are available for supplementing the jobshop facility in the event that the acquisition of the new computer is excessively delayed. An analysis should be undertaken to determine the feasibility and cost-benefits of the options available (see Section 2.5).

### 5.2.3 Coordination of Software Test Tool Development

#### Conclusion

At NAFEC, several organizations are proceeding independently with plans for developing special software production tools for their particular applications (see Sections 2.1.6 and 2.5).

#### Recommendation

NAFEC should actively coordinate the development of commonly-used NAFEC test tools, especially those needed for NAS en route and terminal support, to insure that all NAFEC users will benefit from the new capabilities.

### 5.3 ATC Simulation Support Capabilities

#### 5.3.1 ATCSF Support

#### Conclusion

Efforts are currently under way to upgrade and modernize the ATCSF, as a general-purpose vehicle for efficiently simulating the ATC environment. Current ATCSF hardware and software and the methods for specifying the test environment and preparing the test scenarios in the ATCSF are cumbersome and time consuming. Also, the procedures for initializing and verifying the interfaces between the ESSF and TATF are error-prone and time-consuming (see Section 2.4).

#### Recommendation

The efforts to modernize the ATCSF should continue. Capabilities should be developed to automatically convert site adaptation data for input to the ATCSF data bases. Also, a capability should be developed to simplify the preparation of simulated flight scenarios. The ATCSF software should be modified to allow use of an external master time-synchronization signal to provide effective interfacility synchronization.

### 5.3.2 Site Simulation in the ESSF

#### Conclusion

Equipment limitations and cumbersome adaptation data preparation procedures restrict the ability to simulate field-site operations in the ESSF. The restrictions require the Air Traffic Service to certify new software system releases largely through the use of "key site testing". AAT has recently developed an improved capability to automate the conversion of field-site adaptation data to ESSF adaptation data. The capability, designated ACE-SIM, will be available to other programs requiring simulations of real site operations (see Section 2.1.6).

#### Recommendation

The possibility of using the ACE-SIM system, or a modification thereof, should be investigated for use as a general purpose capability which can support development projects as well as operational testing.

### 5.4 Long-Term Facility Development

#### 5.4.1 General Planning

#### Conclusion

A greater degree of long-term technical program planning is required at NAFEC to provide a better awareness of future development and support programs which may impact NAFEC support resources. Better planning will improve NAFEC's ability to identify projects and justify budgeting for DT&E facility development (see Section 4.3).

#### Recommendation

A Master Technical Program Plan should be developed which addresses all NAFEC ATC programs/projects and reflects work and associated budget and resource requirements for five-year periods. The Master Plan should become an integral part of the overall FAA E&D Plan. The planning process should allow NAFEC to participate at an early stage and to play a more responsible role in overall E&D planning.

#### 5.4.2 Shared Usage of Facilities for E&D and Operational Support

##### Conclusion

Sharing of the ESSF for E&D and field system support has not been an effective arrangement. Configuration management restrictions have complicated the integration of development systems into the facility, and operating service priorities in scheduling the facilities can affect development project schedules (see Sections 2.5.2.4 and 4.2).

##### Recommendation

Long-term planning for future system support facilities (e.g., ATC Computer Replacement) should consider the differences in requirements for system development and field system support. Serious consideration should be given to independent support facilities whenever possible.

#### 5.4.3 Small-Scale Support Facilities

##### Conclusion

There will be a continuing requirement for small-scale laboratory facilities to support the development and testing of advanced automation concepts involving man-machine interfaces and control sector design (see Section 4.1.6). Current facilities (e.g., CCIL) generally lack the capabilities which will be required to support the advanced automation development projects scheduled for the next several years (e.g., ETABS, Data Link, AERA).

##### Recommendation

Planning should begin now to enhance existing small scale laboratories (e.g., CCIL) or develop new facilities (e.g., ATCSF) to support experimentation and testing of advanced ATC automation concepts involving controller interfaces and sector position design. The facility must be responsive and flexible to meet requirements for dynamic demonstrations and concept test and evaluation.

APPENDIX A

ESSF SYSTEMS AND EQUIPMENT

This Appendix includes the following subsections:

- A.1 First Floor Plan, Building #149
- A.2 Second Floor Plan, Building #149
- A.3 NAS En Route Laboratory
- A.4 ESSF Digital Surveillance Data Patching
- A.5 Coded Time Source Subsystem Interconnections
- A.6 Coded Time Source Unit Block Diagram
- A.7 OS Jobshop

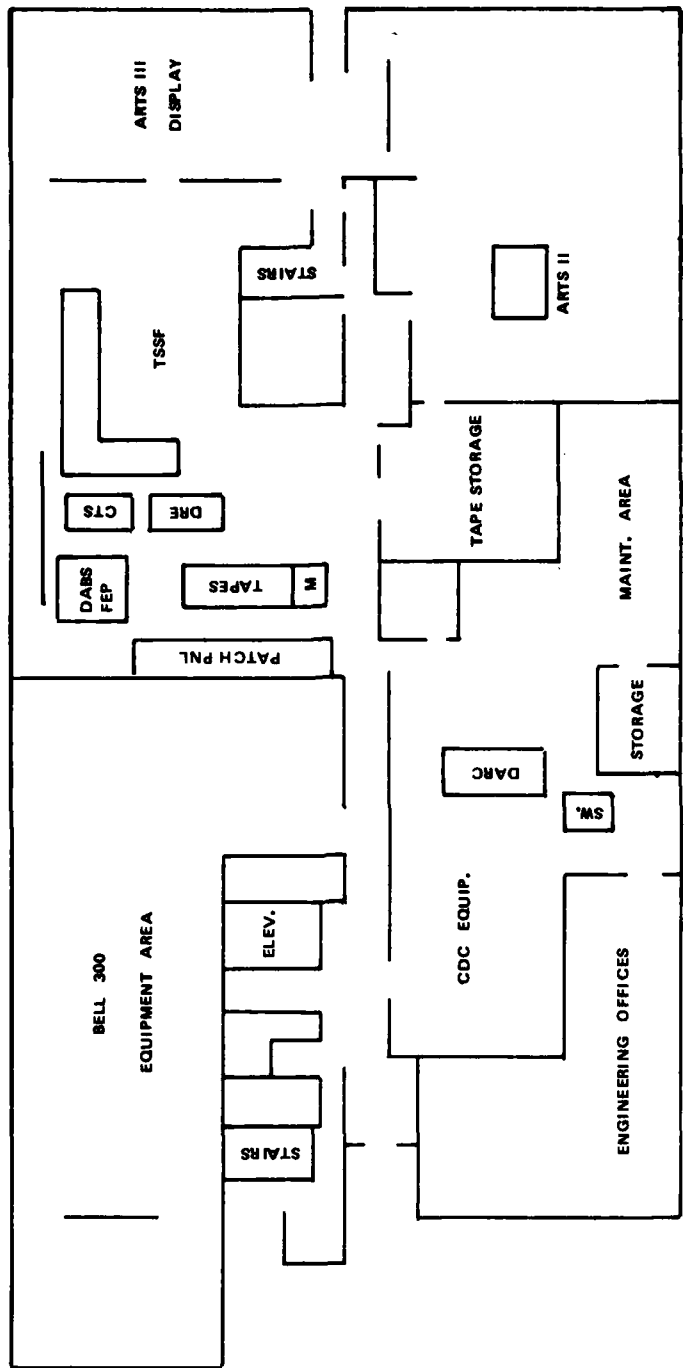

FIGURE A-1 NAFEC BUILDING #149: FIRST FLOOR EQUIPMENT LOCATIONS

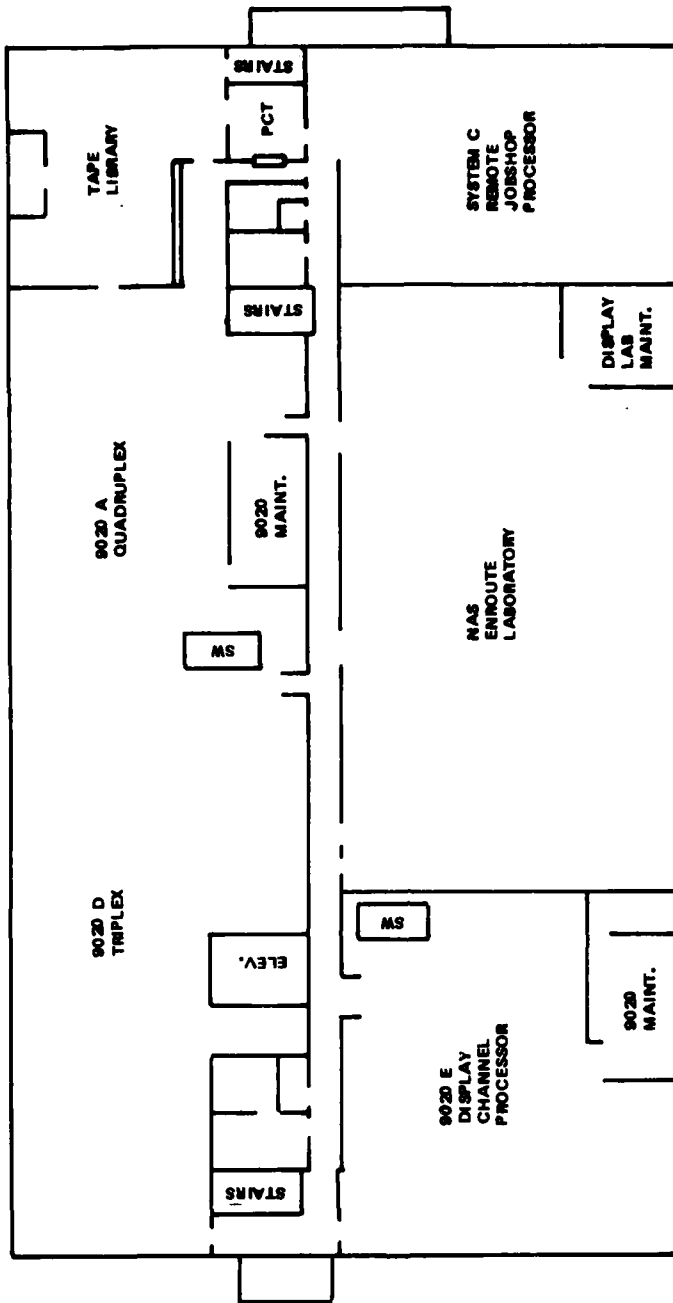

FIGURE A-2 NAFEC BUILDING #149: SECOND FLOOR EQUIPMENT LOCATIONS



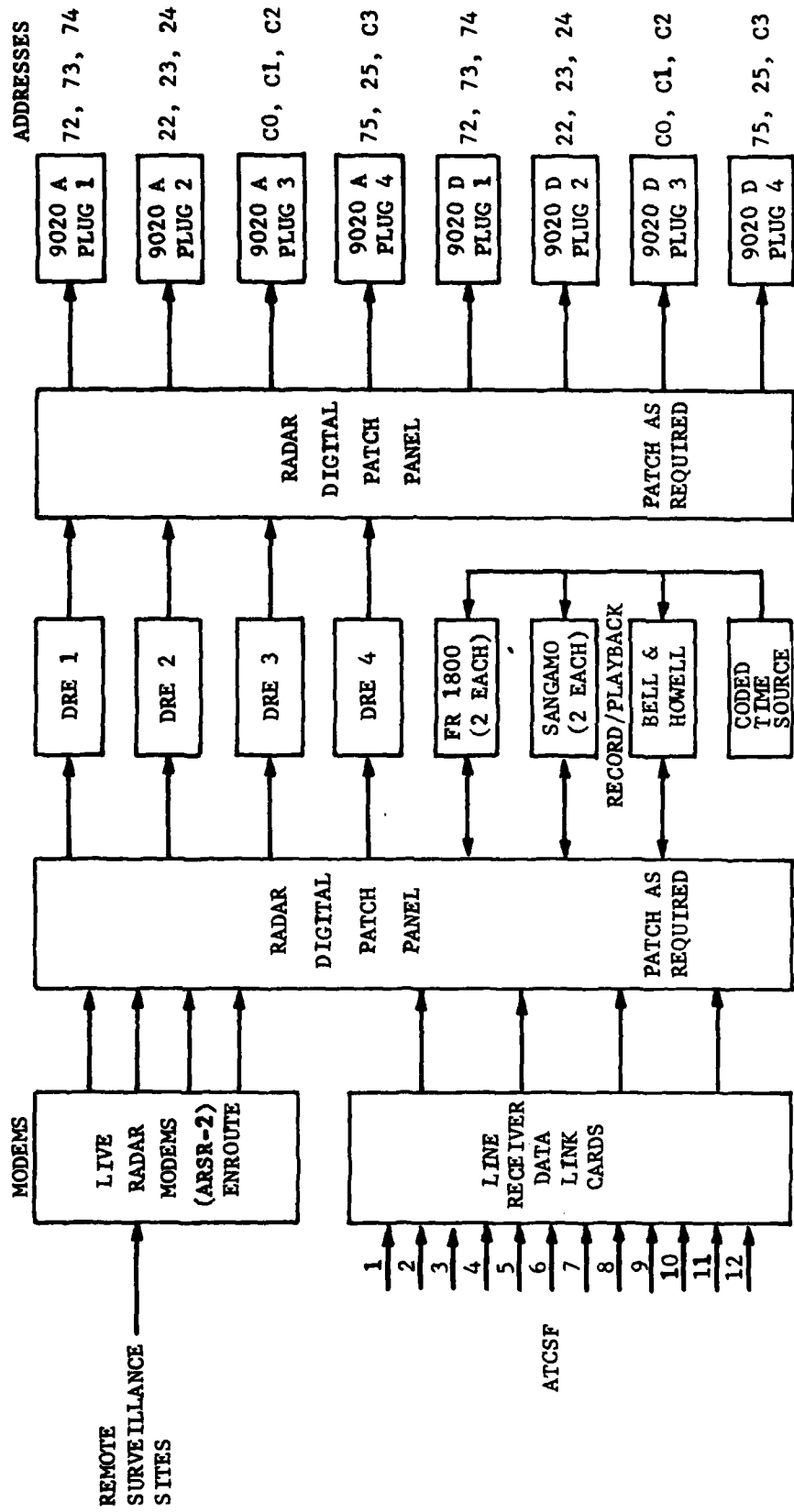

FIGURE A-4 ESSF DIGITAL SURVEILLANCE DATA PATCHING

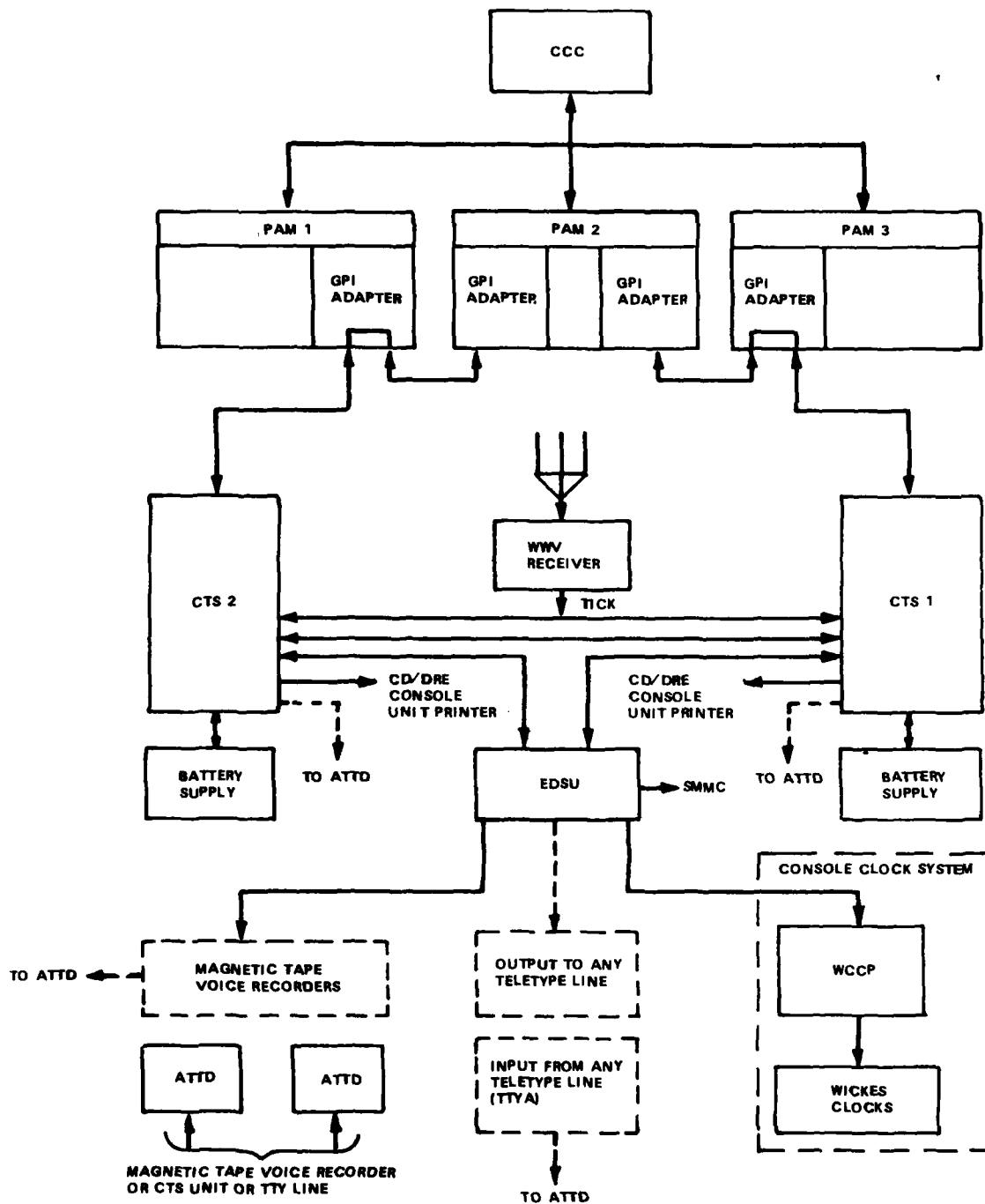

FIGURE A-5 CTS SUBSYSTEM INTERCONNECTIONS



## A.7 OS Jobshop

### A.7.1 General

The OS Jobshop uses a modified IBM 360/50 (i.e., 9020A). Storage capacity is 1.5 million bytes. The major peripherals of the Jobshop system consist of: 1 IOCE, 9 disk drives plus 4 disk drives shared with the 9020E, 8 tape drives, 1 high-speed line printer, 1 CR/CP, and a communications controller to handle input/output with remote terminals through SUPERWYLBUR (see item (3) on page A-11).

A print station consisting of an IOCE computer, 5 tape drives, 3 high-speed printers, and a CR/CP, is used primarily to handle high-volume printing jobs from the Jobshop, as well as the other 9020s.

A diagram of the Jobshop is provided in Figure A-7. A list of hardware components is included in Table A-1.

### A.7.2 Description

The major operating system used in the Jobshop is OS/360. This is a standard system for the IBM/360 computer, which was modified for execution on the 9020 hardware. The modified operating system is sometimes referred to as "OS/9020". OS/360 has three subsets: (1) OS/MVT - Multiprogramming with a Variable number of Tasks, (2) OS/MFT - Multiprogramming with a Fixed number of Tasks, and (3) OS/PCP - Primary Control Program. Only OS/MVT and OS/PCP were modified for the 9020 computers.

OS/MVT is a multi-job system capable of processing several jobs concurrently. At NAFEC, the system is normally configured to operate with 4 initiators, meaning that up to 4 jobs can be processed simultaneously (in addition to SUPERWYLBUR and HASP), provided that sufficient memory and peripheral devices are available.

Due to the lack of sufficient disk drives, the Air Route Traffic Control Centers (ARTCCs) use OS/PCP (Primary Control Program). This operating system processes only one job at a time, and is generally less efficient than OS/MVT with regard to computer utilization. At NAFEC, OS/PCP is used to verify programs prior to shipment to the field sites. In addition, some NAFEC users prefer to operate under OS/PCP.

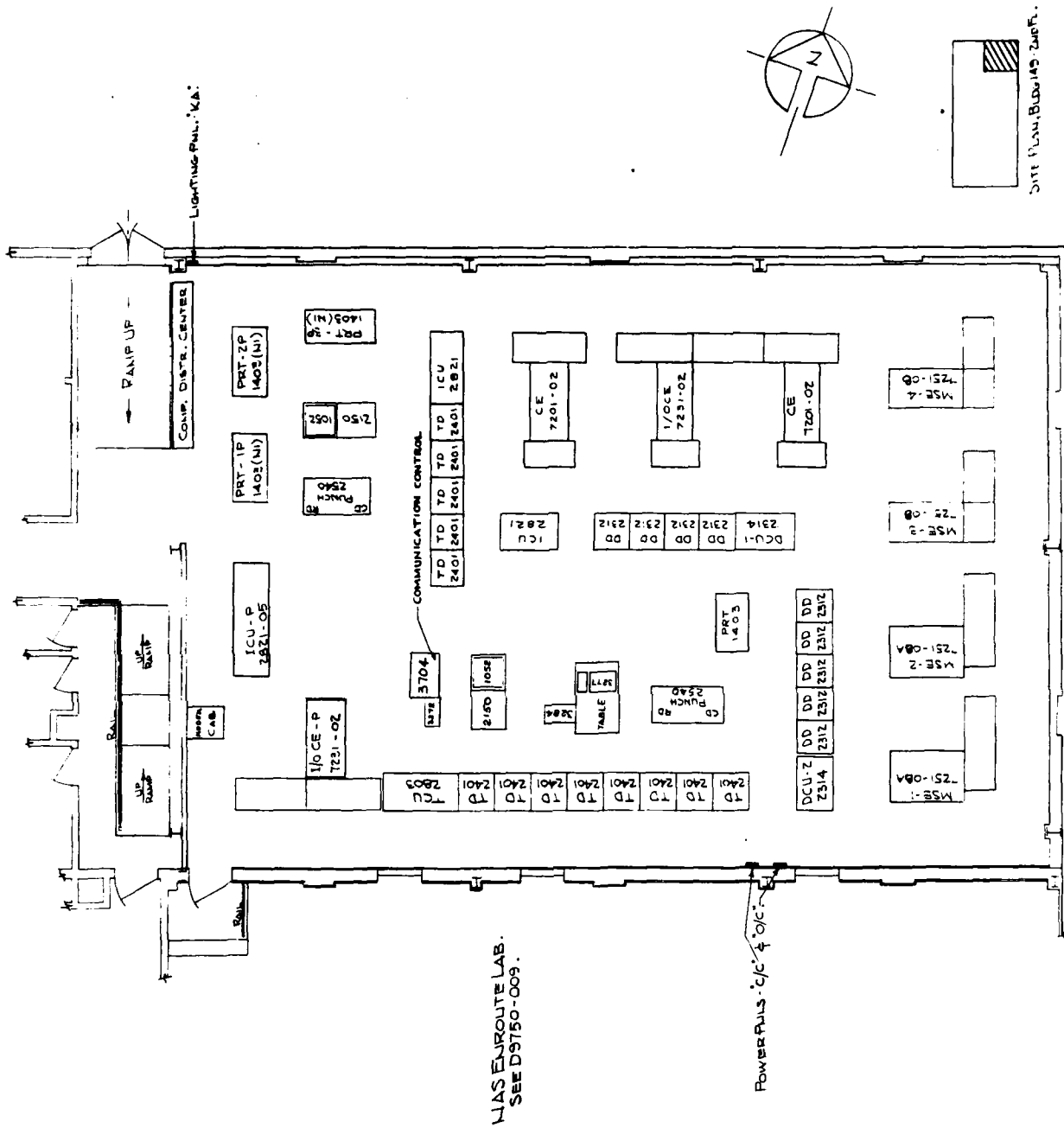

FIGURE A-7 JOBSHOP ROOM LAYOUT

TABLE A-1

NAS JOBSHOP COMPUTER SUBSYSTEM

IBM 9020A Computer Complex (System C, IOCE-P)	
IBM 7201-01 Computing Element	2 EA
IBM 7251-08 Storage Element	2 EA
IBM 7251-08A Storage Element	2 EA
IBM 7231-02 Input/Output Control Element	1 EA
IBM 3704-A01 Communication Controller	1 EA
IBM 1052-07 Input/Output Typewriter	1 EA
IBM 3284-02 Line Printer	1 EA
IBM 3277-02 Display Station	2 EA
IBM 3272-02 Control Unit	1 EA
IBM 2821-01 Integrated Control Unit	2 EA
IBM 2821-05 Integrated Control Unit	1 EA
IBM 2803-01 Tape Control Unit	1 EA
IBM 2540 Card Read Punch	1 EA
IBM 2401-02 Magnetic Tape Drive	5 EA
IBM 2401-03 Magnetic Tape Drive	3 EA
IBM 2314-A1 Disk Control Unit	3 EA
IBM 2312-A1 Disk Drive	13 EA
IBM 2150-01 Input/Output Console	2 EA
IBM 1403-N1 High Speed Printer	4 EA

OS/360 was first installed on NAFEC's 9020s in 1973. It has become the major operating system for the NAS Operational Support System (i.e., the off-line system, providing many non-realtime data processing functions). OS/360 was intended to replace many of the functions of NOSS, the original NAS-support operating system. NOSS, a tape-oriented system, is still being used today, but the bulk of off-line support jobs at NAFEC are now run under OS/360.

At NAFEC, the jobshop usage consists of OS/MVT and OS/PCP, as well as NOSS jobs. But the OS Jobshop facility is dedicated for execution under OS/MVT.

Following is a brief review of the major software systems used under OS/360 at NAFEC:

(1) Compilers

JOVIAL is the major high-order-language used in support of the NAS en route system. JOVIAL compilations and executions account for a major part of the NAFEC jobshop workload.

Other compilers available, but not used as heavily as JOVIAL, are: FORTRAN and COBOL.

(2) Assembler

OS/BAL (Basic Assembler Language) is the assembler language used in the NAS en route system.

(3) Conversational Remote Job Entry

Users can submit OS/9020 jobs either on card decks, or remotely through a terminal. The software system supporting the remote entry capability is SUPERWYLBUR, which replaced an earlier system called CRJE. SUPERWYLBUR permits the user to prepare and edit a program, or a data set, in a conversational mode. When desired, the program, or data, can be submitted to the 9020 to be queued in the normal batch stream. In addition, the user may--through his terminal--send queries regarding the job status (e.g., queued, running, or completed) and retrieve the job output, or portions thereof, on his terminal. It should be emphasized that SUPERWYLBUR does not support interactive compilation, assemblies, or job execution. These jobs must run in the normal batch mode.

(4) Utilities

In addition to the standard utilities provided under OS/360 (e.g., sort/merge), many special purpose utilities were developed for NAS operational support. These include programs for data handling of NOSS, OS, or NAS tape files.

(5) DART - Data Analysis and Reduction Tool

DART is the major data reduction program used for extracting and analyzing data recorded on SAR tapes (System Analysis Recording) at the ARTCCs. DART collects the pertinent data as specified by the user, and performs data editing, sorting, and statistical analyses. DART executions are typically lengthy, and usually involve processing of several SAR tapes as part of a single job.

(6) Program Management (PM)

PM was designed to support NAS En Route software development by providing system build inputs and updating master datasets. The program supervises compilations and assemblies of NAS software modules; produces a system build input consisting of a so-called TRIO which is a set of four (sic) members (i.e., source listing, compilation/assembly listing, object deck, and cross reference deck); and updates the master data set by replacing an entire member or using only source changes. PM jobs constitute a sizable portion of the Jobshop workload.

## APPENDIX B

### TATF SYSTEMS AND EQUIPMENT

#### B.1 General

Three ARTS computer systems are currently located in the TATF (see Figure B-1). Each system includes two IOP's with interfaces to other system elements and to peripheral equipment. The interfaces are established via input/output channel connections. Table B-1 identifies the current channel assignments for the three systems. System #1 is currently used primarily for development of ARTS IIIA. System #2 is dedicated to operating the Radar Beacon Simulator (RBS), and is normally not scheduled for individual users. A VI-C tape drive is used with System #2 instead of an Integrated Magnetic Tape Unit (IMTU) used with Systems #1 and #3. System #3 is used primarily for testing the All Digital System (ADS) which is used for DABS development. Accordingly, the Communications Multiplexor Channel (CMC) used with DABS is interfaced to System #3. ADS requires All-Digital displays in the control room. Vertical consoles #7 through #10 are All-Digital consoles and are dedicated to the ADS system tests. Vertical consoles #1 through #4 are Time-Shared ARTS III consoles.

At this time, Systems #1 and #2 are composed of Type "A" IOP's. System #3 uses type "B" IOP's. These type designations indicate the modifications which were made to the IOP's for the ARTS IIIA system. The type "A" IOP's are experimental and incorporate an interim design. The type "B" systems are currently being implemented in field sites. The IOP's in the TATF are scheduled to be modified to type "B".

Two patch panels in the facility are used to establish data interfaces. One patching arrangement is collocated with the CMC in an equipment rack. A switch to select external radar sites (NAFEC, Clementon, and Elwood DABS sensors) in connection with printed circuit amplifier boards controls the data interfaces to the Communications Transmitter Adapters and Communications Receiver Adapters. These adapters, part of the Communications Multiplexor Channel, process data in accordance with Common ICAO Data Interchange Network (CIDIN) requirements.

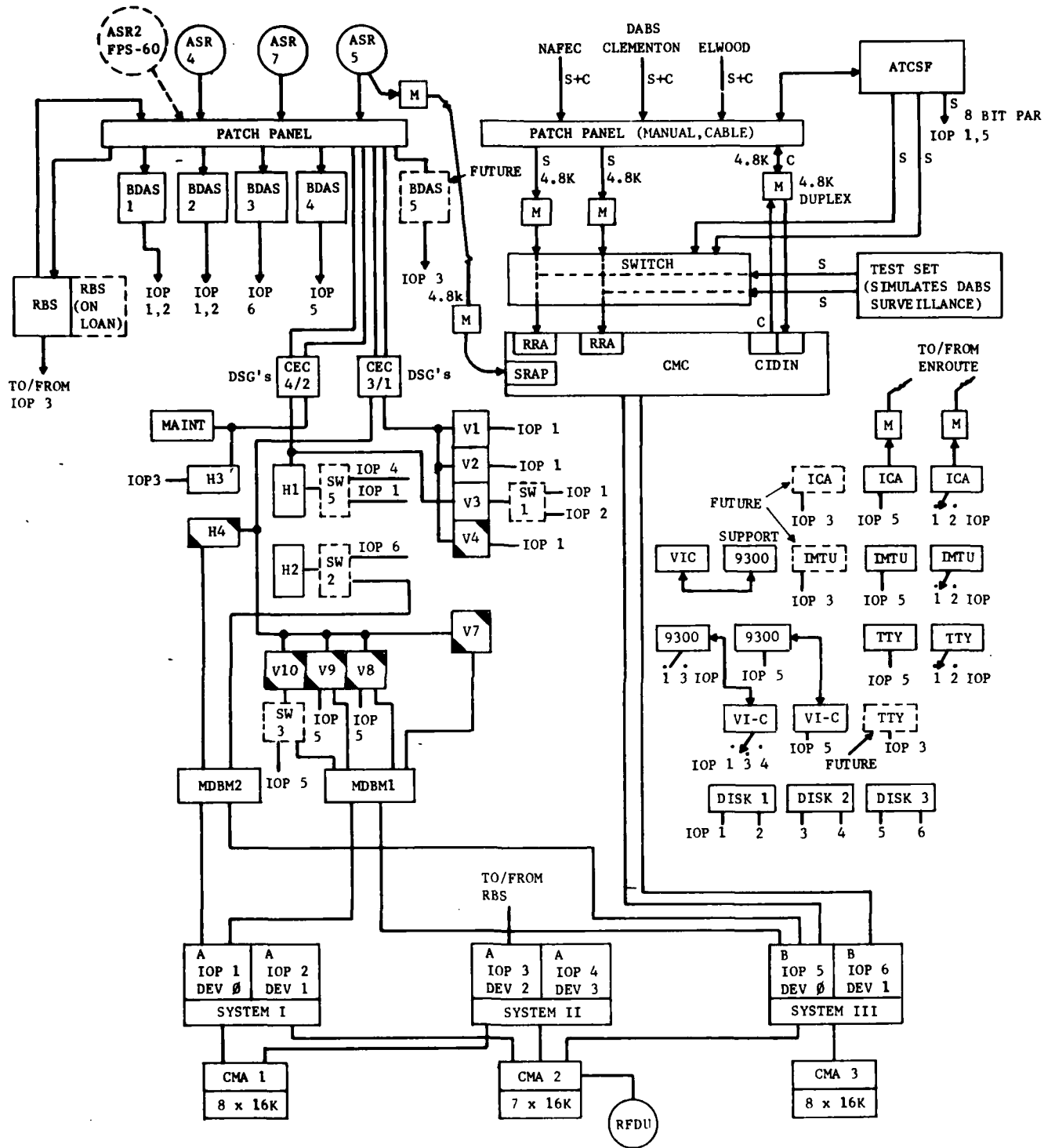

FIGURE B-1 TATF SYSTEMS OVERVIEW

TABLE B-1  
TATF SYSTEMS I/O CHANNEL ASSIGNMENTS

	SYSTEM 1		SYSTEM 2		SYSTEM 3		
	IOP 1	IOP 2	IOP 3	IOP 4	IOP 5	IOP 6	
IOP CHANNEL NUMBER (OCTAL)	0	BDAS 1* ← BDAS 1* BDAS 2* ← BDAS 2*	BDAS 5**	-	BDAS 4	BDAS 3	
	1	ICA* ← ICA*	ICA**	-	ICA	-	
	2	IMTU* ← IMTU*	IMTU**	-	IMTU	-	
	3	TTY* ← TTY*	TTY**	-	TTY	-	
	4	VI C***	-	VI C***	VI C***	VI C	-
	5	Disk 1	Disk 1	Disk 2	Disk 2	Disk 3	Disk 3
	6	V1 Display	V3 Display Switch	RBS 1	H1 Display Switch	-	-
	7	MDBM 1	-	RBS 1 Clutter	-	MDBM 1	-
	10	V3 Display Switch	↑	(RBS 3)	-	V8 Display	H2 Display Switch
	11	V2 Display Switch		H3 Display	-	V9 Display	-
	12	H1 Display Switch	No Channel	(RBS 3 Clutter)	-	CMC	CMC
	13	9300**** Switch	Expansion	9300**** Switch	-	9300	-
	14	MDBM 2		↑	↑	MDBM 2	↑
	15	V4 Display		No Channel Expansion	No Channel Expansion	V10 Display Switch	No Channel Expansion
	16	ATCSF Switch		↓	↓	ATCSF Switch	↓
	17	--	↓	↓	↓	--	↓

- \* Switchable Unit
- \*\* Future
- \*\*\* One Unit Switchable to IOP 1, 3 or 4
- \*\*\*\* One 9300 Switchable to IOP 1 or 3

The other patch panel is a plugboard which contains a large number of cable connectors to interconnect various inputs to various Beacon Data Acquisition Subsystems (BDAS). The board connectors provide a panel for many separate coaxial cables which carry the signals from the ASR sites.

### B.2 Basic ARTS III

The basic ARTS III system is a beacon tracking level system. Figure B-2 illustrates a system overview. Beacon position data are displayed to TRACON controllers in association with alphanumeric symbology. Primary and secondary radar video presentations are displayed concurrently with the symbolic and alphanumeric data. The system also provides interface capability to exchange data with adjacent computer systems, e.g., the ARTCC 9020's. Basic ARTS III systems include an Integrated Magnetic Tape Unit (IMTU) used principally for loading the software and a teletypewriter system which is used primarily for on-line printing of system status messages. ARTS III operates in single or dual beacon mode. In the dual beacon configuration, two ASR surveillance data channels are input to two ARTS III systems which share common memory modules.

### B.3 ARTS IIIA

The ARTS IIIA system employs enhanced software and hardware to increase the capability of the basic ARTS III system. The following capabilities are provided by the ARTS IIIA enhancements:

- (a) Processing, tracking and display of all primary and secondary radar data from one or more ASRs.
- (b) Improved quality and performance of the existing ARTS III tracking capability by the acquisition and display of all radar-derived (primary and beacon) aircraft targets.
- (c) Improved fault detection and isolation.
- (d) Capability for continued operation at levels consistent with system availability when one or more system elements have failed.
- (e) Capability for continuous recording of input, output and system status data.
- (f) Capability for further functional growth and increased capacity.

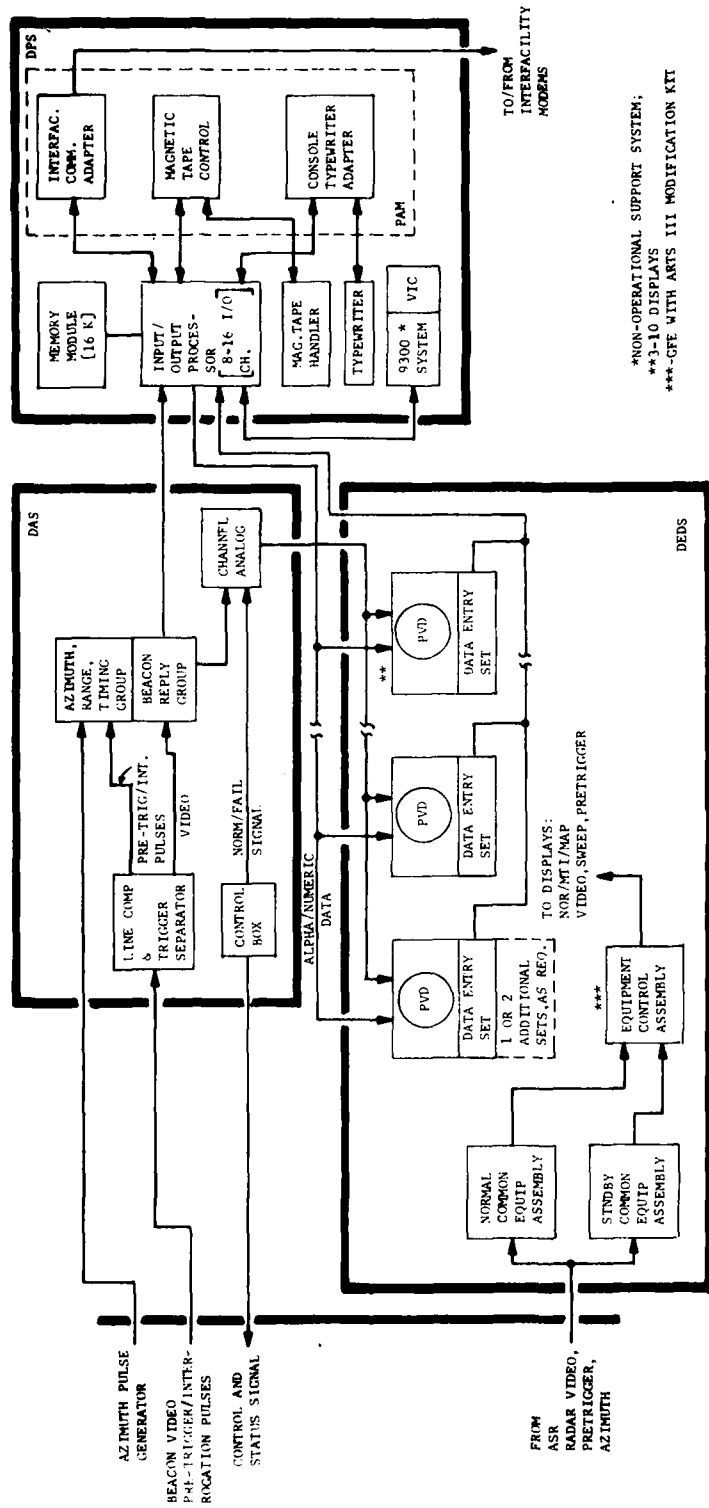

\*NON-OPERATIONAL SUPPORT SYSTEM;  
 \*\*3-10 DISPLAYS  
 \*\*\*-CPE WITH ARTS III MODIFICATION KIT

FIGURE B-2 BASIC ARTS III SYSTEM

- (g) Capability for non-interrupted 24 hours operation in support of operational requirements.
- (h) Capability for further modular expansion of hardware and software.

Continuous Data Recording is provided by means of added peripheral devices as well as utilization of existing peripherals. A Fail-Soft capability is provided through redundant equipment and software. A Data Acquisition Subsystem (DAS) for each sensor is available to provide improved beacon and radar detection and data processing. A Reconfiguration and Fault Detection Unit (RFDU) allows any IOP assignment to any Memory Module. The ability to display broadband video together with computer derived symbology is retained.

#### B.4 ARTS All Digital System

Enhancements to ARTS which are employed in the Tampa-Sarasota system have been adapted for use in the TATF in support of the DABS program. The following modifications were made to the baseline multisensor system to perform the functions of an All Digital System:

1. Incorporate the fail-safe/fail-soft Multiprocessor Executive (MPE).
2. Revise Keyboard Input logic to interface with Multiplexor Display Buffer Memories (MDBMs).
3. Expand Keyboard Function processing to include several ARTS field modifications, and also special functions designed to facilitate system testing.
4. Revise the presentation of terminal map data, range marks, weather data, display of unused reports and display of history trails.
5. Provide several display alternatives in each of the following areas:
  - a. Placement of Controller Discrete Symbol in FDB.
  - b. Indication of Identing aircraft.
  - c. Display of range marks, history trails, and weather.
  - d. Indication of aircraft in handoff status.

- e. Display of emergency status.
- f. Flexible selection of track symbology, vector line textures, data category brightness, and certain blink data options.

In addition, a DABS/ARTS terminal interface verification program is used to verify the software/hardware interface between the DABS Engineering Model and the ARTS facility. This is an off-line function.

#### B.5 ARTS All Digital System Configuration in the TATF

The All Digital System employs controller displays which are modified to provide input/output functions as required. While the basic ARTS system displays analog data from the analog channel in the Data Acquisition System, the All Digital System displays data from the Multiplex Display Buffer Memory (MDBM). The buffering of data for display reduces the processing workload of the IOP. (Current IOP channel assignments are listed in Table B-1.)

DABS digital input data from the Sensor Receiver and Processor (SRAP) Model #2, from a DABS sensor, or from the ATCSF are transmitted to the ARTS IOP's via the Communications Multiplexor Channel (CMC). The CMC is rack-mounted equipment which includes the Radar Receiver Adapters, Communications Receiver Adapters, and Communications Transmitter Adapters. These adapters interface the ARTS IOP's with the external DABS facility. Data on the DABS communications channel is formatted according to the Common ICAO Data Interchange Network (CIDIN) standard.

#### B.6 TATF Support Equipment

##### (1) Radar Beacon Simulator (RBS)

The RBS generates simulated analog primary and beacon surveillance data to be input to the ARTS DAS in the same channel as live ASR input data.

To use the RBS a scenario tape is prepared off-line. This tape becomes the input to drive the RBS system. The output from the RBS driver is analog data which are input to the Radar and Beacon Data Acquisition Subsystems (RDAS and BDAS).

(2) Time Code Generator (TCG)

A high precision clock manufactured by Datum Precision is rack-mounted in the computer room in the TATF. The Model 9110 TCG provides the following outputs:

- . Display - a front panel display presents time in seconds, minutes, hours and days from 0 to 365 days, 23 hours, 59 minutes, and 59 seconds;
- . Serial code - standard IRIG format B, BCD coding for seconds, minutes, hours and days;
- . Carrier modulation - carrier frequency of 1000 Hz., AM; 0-5 volts peak, 75 ohms, or 0 to 10 volts peak into 600 ohms;
- . DC level shift;
- . Parallels - 30 lines representing seconds, minutes, hours and days in binary coded decimal, standard TTL levels.

The TCG can be synchronized to external pulses. Currently, the NAFEC range time is input to the TCG via the patch panel in the building #149 radar distribution area. Although the TCG is available in the TATF, the ARTS III systems are not designed to operate with an external time of day signal. A software modification is necessary to allow the ARTS III system to use the TCG signal.

(3) Remote Computer Facility

Several CRT terminals in the TATF can connect via telephone to the UNIVAC 1108 computer in the Bureau of Standards, Gaithersburg, MD. UNIVAC programmers at NAFEC use the system for software development.

(4) TESDATA 1286 Hardware Monitor

The TESDATA 1286 is a programmable hardware monitoring system. Probes can be attached to selected points in the hardware to record various electronic signals in the computer. Subsequently, the recorded data can be reduced and analyzed to provide information on CPU and memory utilization.

(5) ARTS III 9300 System

The 9300 provides off-line support at a number of terminal facilities which provide software support to other ARTS III facilities that don't have this equipment. The TATF has two 9300 systems, generally used for peripheral work such as printing, and card reading and punching.

APPENDIX C

SYSTEMS TO BE INTEGRATED WITH THE ESSF AND TAPP

This Appendix includes the following figures:

- C-1 ETABS System Configuration
- C-2 DARC System Configuration
- C-3 TIPS Information Flow
- C-4 Tower Display Subsystem (a subset of TIPS)

9020 D

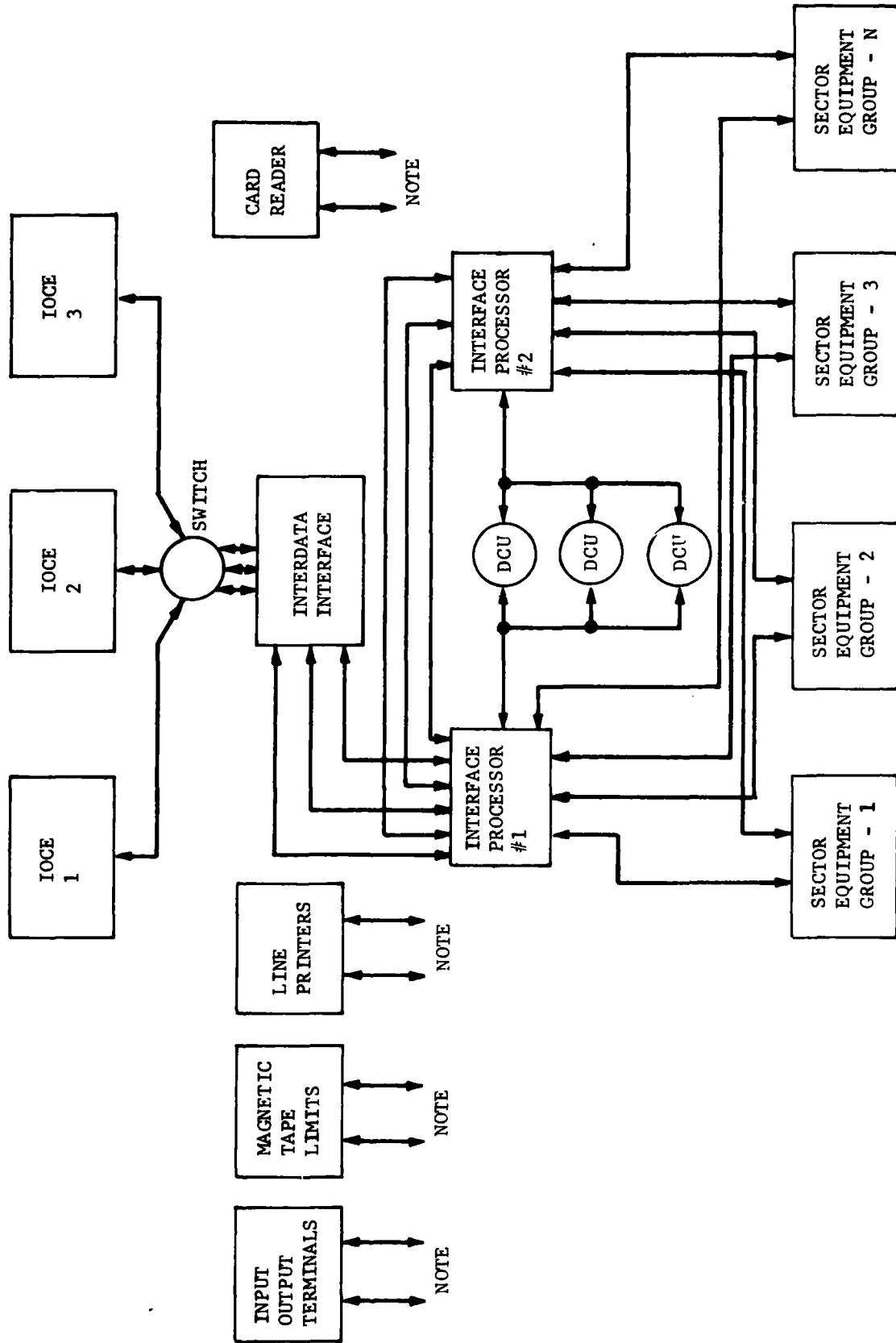

NOTE: SWITCHABLE TO INTERFACE PROCESSORS 1 AND 2

FIGURE C-1 ETABS SYSTEM CONFIGURATION

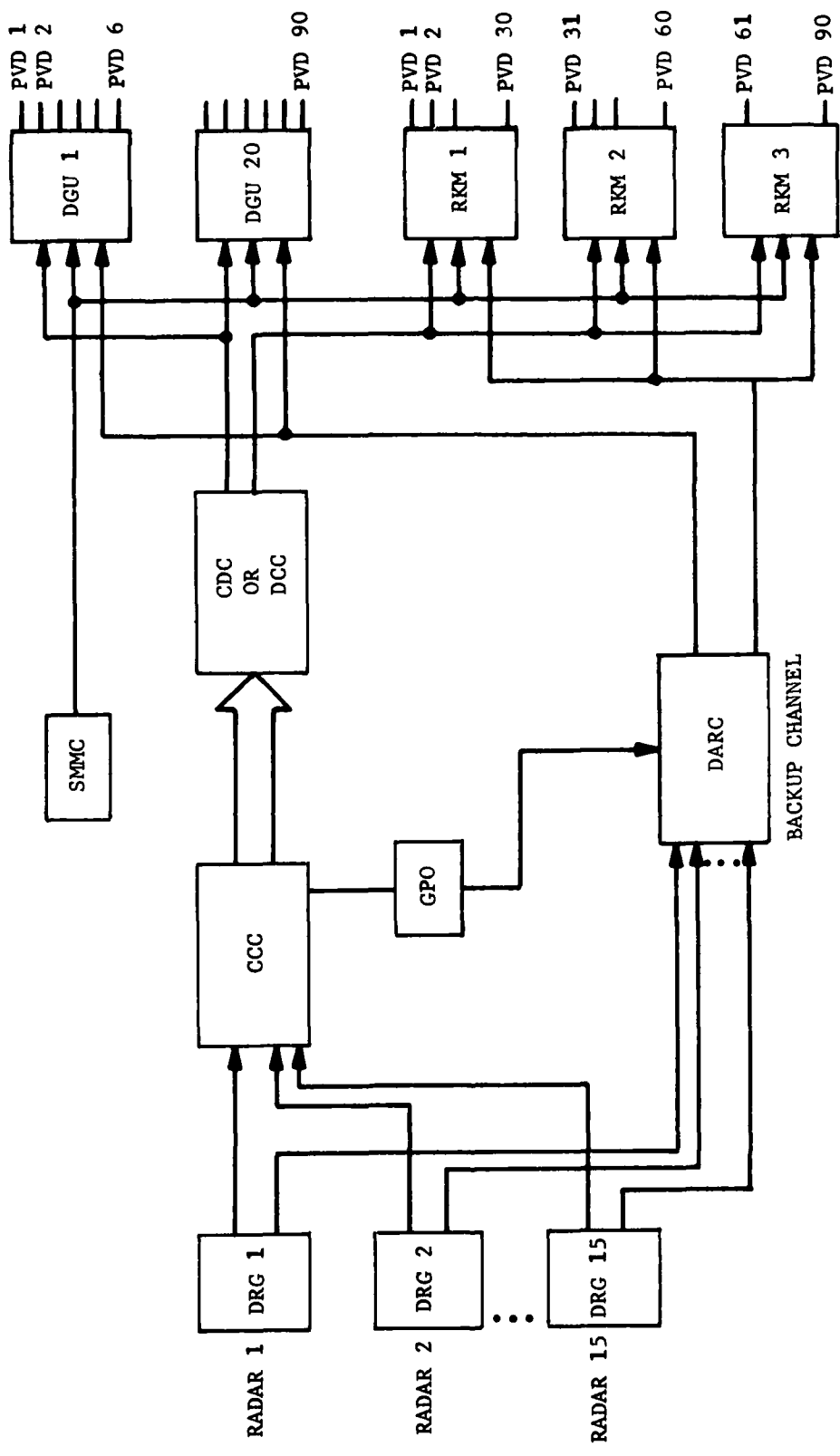

FIGURE C-2 DARC SYSTEM CONFIGURATION

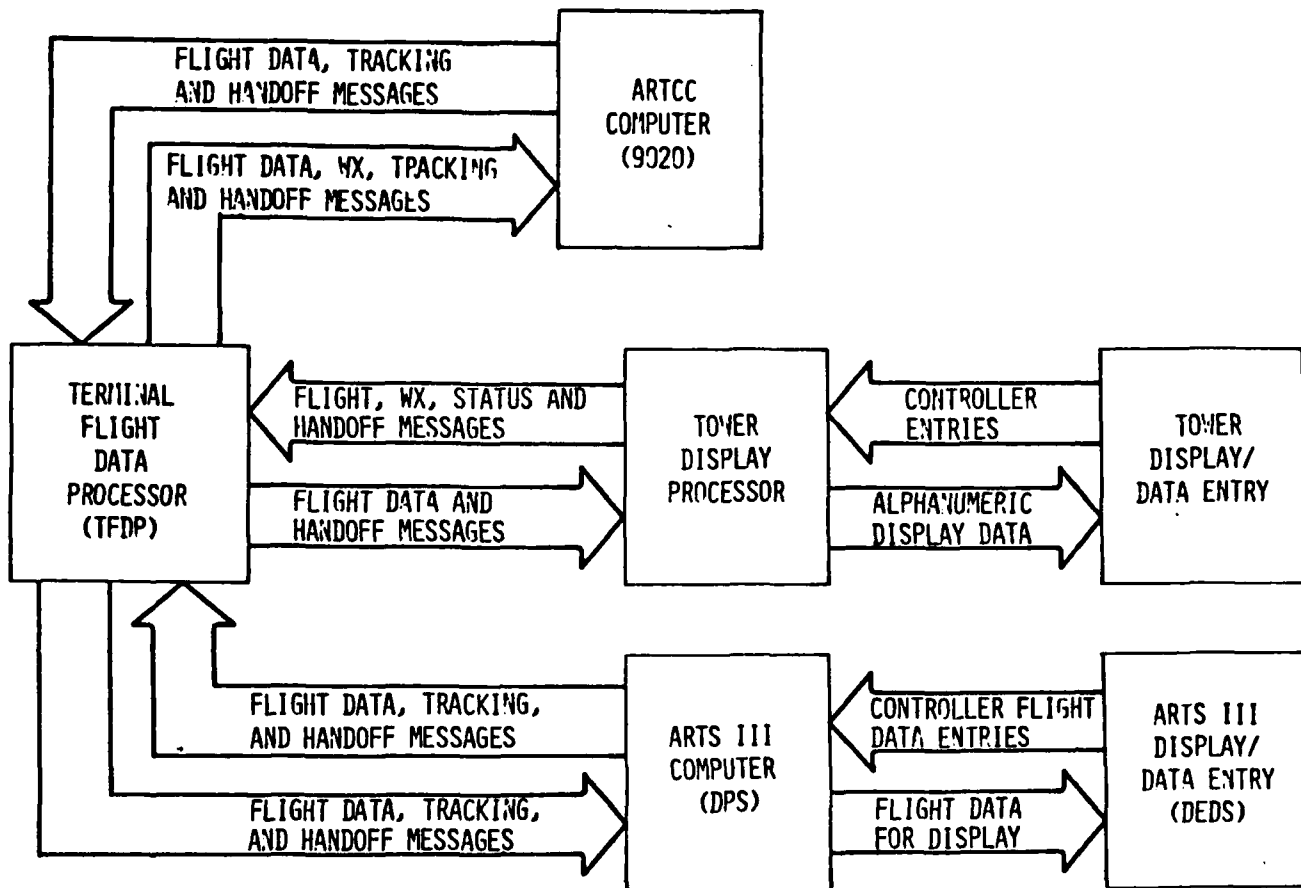

FIGURE C-3 TIPS INFORMATION FLOW

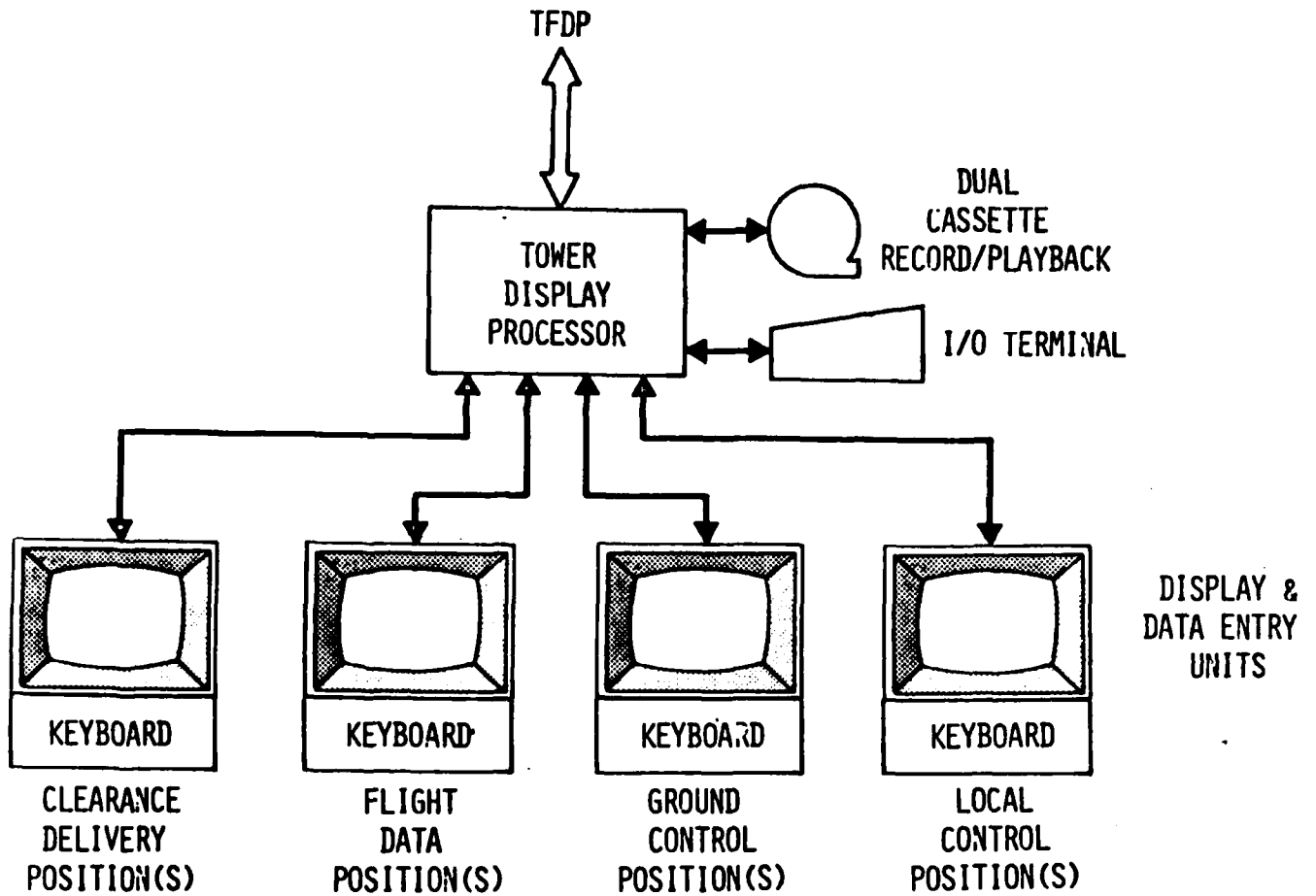

FIGURE C-4 TOWER DISPLAY SUBSYSTEM (A SUBSET OF TIPS)

## APPENDIX D

### A SUGGESTED CONCEPT FOR TIME SIGNAL DISTRIBUTION TO NAFEC ATC LABORATORIES

#### D.1 General

The concept described herein will provide a general purpose time reference signal for the computer systems in the NAFEC ATC test environment. Any of the computer systems or facilities, in any combination thereof, will synchronize on a common time signal which may be set to the value specified by the user. Figure D-1 illustrates a configuration which could be implemented in the new T&A complex at NAFEC in conjunction with the NAFEC Laboratory Signal Switching System.

#### D.2 Functional Characteristics of the Proposed Concept

Four clocks are shown in Figure D-1. Each operates independently, but is synchronized with a one pulse per second signal from an external source. The time signal from each clock is distributed to selected computers. The figure indicates, for example, that the 9020D, ETABS and DARC systems are interfaced for testing and share the same problem time signal. Freezing, resetting and fast-timing of a clock affects only those systems which are using the individual clock signal. As directed by the FACO schedule, the systems are reconfigurable and the clock signal is distributed as required.

#### D.3 Implementation

To implement this concept, some modifications to system hardware, software or both at each of the test facilities are required. (At this time the ARTS III system software is being modified to operate with the DATUM 9110 Time Code Generator output signal. The signal is time-of-day in standard IRIG format B, Binary Coded Decimal for seconds, minutes, hours and days. The ARTS system will be able to use this signal whether the signal is applied from an external facility or from a rack-mounted clock.)

Implementation of a common time of day (problem time) signal for NAFEC test facilities requires the following:

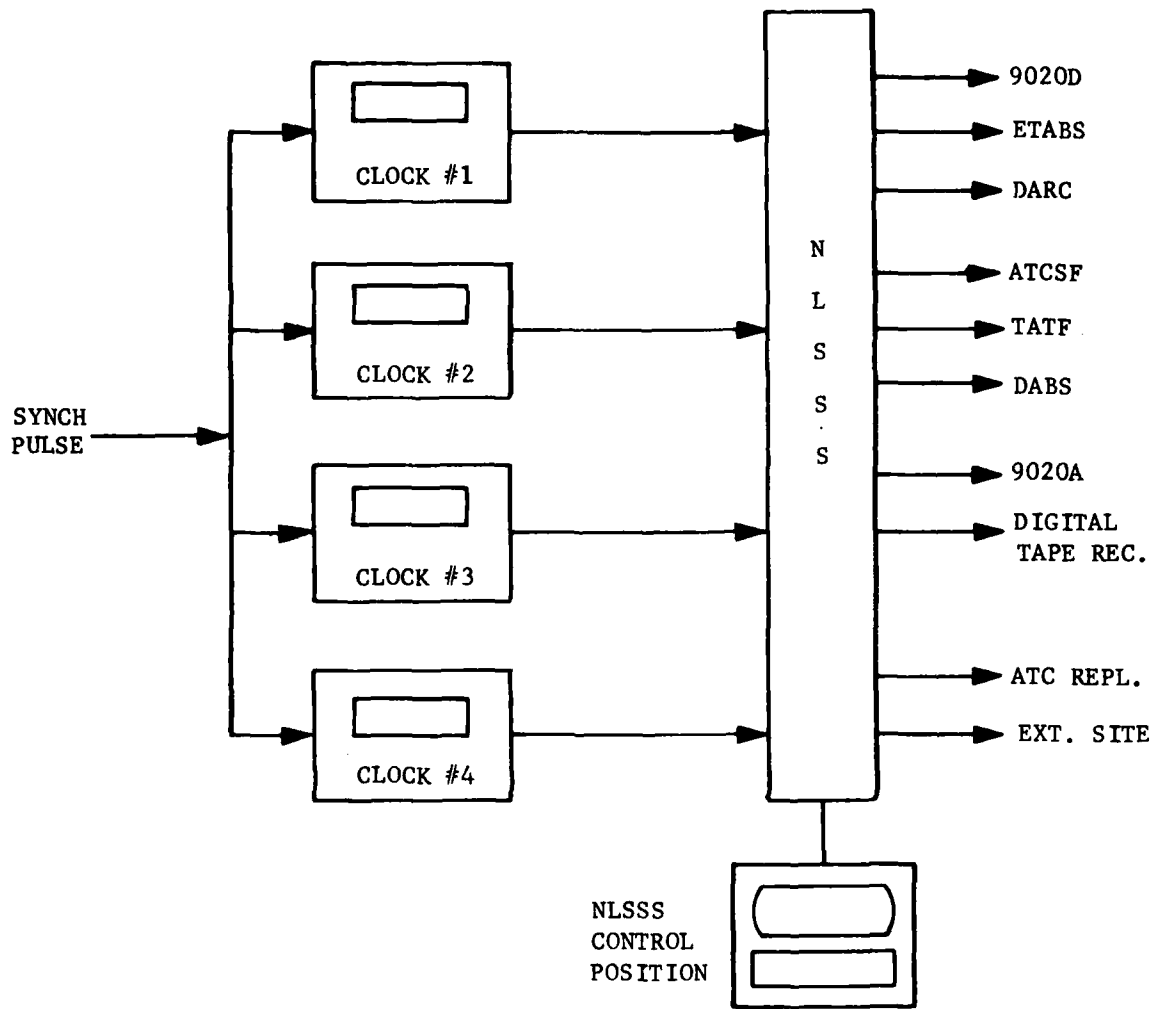

FIGURE D-1 A SUGGESTED TECHNIQUE FOR A NAFEC PROBLEM TIME SIGNAL GENERATOR

- . A standard message format be agreed upon for clock data transmission;
- . The NLSSS be installed and operable;
- . A number of clock signal generators to produce problem time signals which can be individually set and can be distributed by the NLSSS;
- . Computer systems be capable of switching to the NLSSS distributed time signal and using the signal in the agreed upon format.

APPENDIX E

A PROPOSAL FOR A NAFEC ATC LABORATORIES AUTOMATED  
USER BRIEFING CENTER

DESCRIPTION OF THE PROPOSED USER BRIEFING CENTER

A user briefing center, located close to the ATC laboratories would provide users with information required for conducting tests in the ESSF. The information would cover all aspects of ATC from general system description to the current equipment status in the ESSF. To present the information, three kinds of devices could be employed:

- . Film rear projection screen - This information would be unchanging and therefore conveyed on a fixed medium.
- . Video tape cassettes - Information related to the en route, terminal and various ATC systems would be described in training film formats.
- . Interactive computer terminal - A time-share display terminal could be used to provide up-to-date status of NAFEC systems. Facility scheduling information could also be provided using this facility.

Table E-1 contains a list of topics which could be presented to the facility users.

TABLE E-1

USER BRIEFING CENTER: TOPICS

TOPIC GROUP #1: REAR PROJECTED FILM

- . ATC System Fundamentals
- . R, D and A Controller duties
- . Integration of automation
- . NAS Model 3 Functional Description

TOPIC GROUP #2: VIDEO CASSETTES

- . En Route System Operations and Use
- . Terminal System Operations and Use
- . NAFEC laboratories, support services and organization
- . System Configurations
- . User requirement to be supplied to the laboratory staff
- . Laboratory facilities and aids to the user

TOPIC GROUP #3: INTERACTIVE INPUT/OUTPUT COMPUTER INTERFACE

- . Description of specialized aids for system testing, including NOSS and DART subprograms
- . Procedures for input data preparation, software development, and resource acquisition
- . Equipment status and long-term availability
- . Current system/facilities schedule assignments

## APPENDIX F

### FLIGHT SERVICE STATION FACILITIES AUTOMATION PROGRAM

#### F.1 AFSS Program Description

Among the new capabilities expected to evolve for the FSS is the Flight Service Data Processing System (FSDPS) which will be collocated with the ARTCCs, and which would provide centralized computer support to some flight service facilities. Other facilities would continue their manual mode of operation. Those facilities that would have automation support are referred to as Automated Flight Service Stations (AFSS). Figure F-1 illustrates the interfaces of AFSS's, FSDPS's and other facilities in the National Airspace System.

Both manual and automated flight service facilities are assumed to continue to exist during the post-1983 time period. One of the far term improvements to be developed is the use of an expanded weather data base from an Aviation Weather Processor (AWP). The AWP would provide data base maintenance for weather and aeronautical information including editing and reformatting capabilities for the data distributed to the FSDPS's to be utilized in support of both specialists and pilots. Other improvements include the availability of Direct User Access Terminals (DUAT) to be used by pilots in interactively accessing the data base and in filing flight plans. Some DUAT terminals would display graphics to pilots as part of a self briefing. The pilot might also request weather information by push button telephone entry and receive it by computer generated voice utilizing the Voice Response System (VRS). Flight plans entered via push button telephones would be echoed back to the pilot by the VRS system for confirmation or correction. (Although the VRS system is expected to be implemented in the far term, certain elements of it might be implemented in the near term, depending on the outcome of ongoing studies.)

Automation support would be provided for the input, maintenance and retrieval of Pilot Reports (PIREPs) which provide the basis for weather plots manually maintained by the AFSS specialists that handle the En Route Flight Advisory Service (EFAS). PIREPs would be entered by the specialist at the AFSS and would be forwarded to the FSDPS which would in turn forward them to the Weather Message Switching Center (WMSC). PIREPs from other sources would also be sent to the WMSC where a national PIREP data base would be maintained and distributed to the FSDPSs, for use by the automated flight service facilities. Automated support would also be provided to the flight service specialists in the retrieval of weather and aeronautical conditions information.

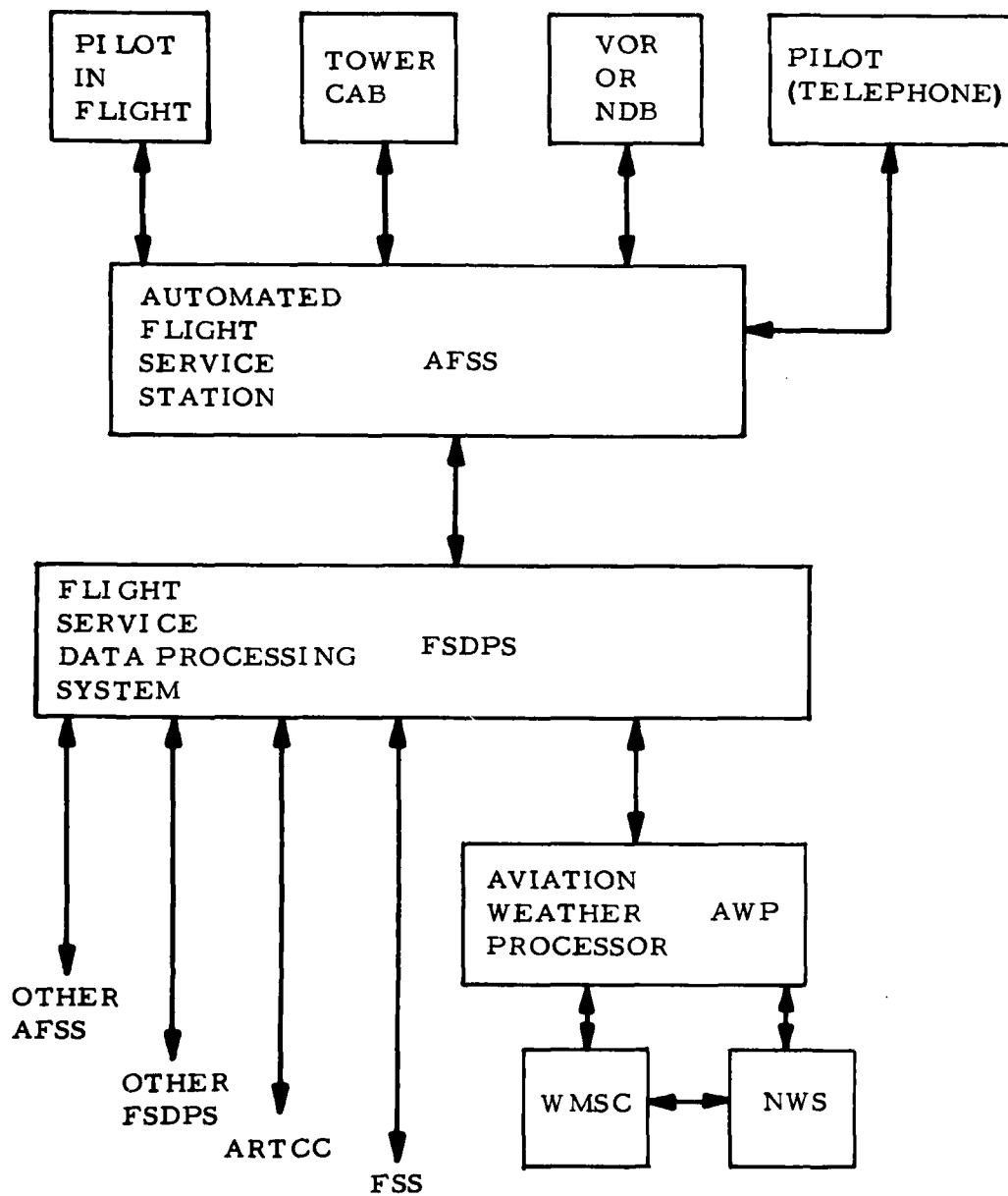

FIGURE F-1 SIMPLIFIED OVERVIEW OF AFSS ENVIRONMENT

APPENDIX G

REFERENCES

1. Dodge, P. O., et al., "Definition, Description, and Interfaces of the FAA's Developmental Programs", MTR-7904, Volumes 1, 2 and 3, The MITRE Corporation, September 1978.
2. FAA-ER-CMF100a, "Engineering Requirement - NAFEC Laboratories Signal Switching System", January 1979.
3. "Digital Simulation Facility User's Guide", Simulation and Analysis Division, Systems Development Branch, June 1975.

APPENDIX H  
LIST OF ABBREVIATIONS

ADS	All Digital System
AERA	Automated En Route Air Traffic Control
AFOS	Automation of Field Operations and Services
AFSS	Automated Flight Service Stations
APR	Agency Procurement Request
ARSR	Air Route Surveillance Radar
ARTCC	Air Route Traffic Control Center
ARTS III	Automated Radar Terminal System Model III
ASDE-3	Airport Surface Detection Equipment-3
ASR	Airport Surveillance Radar
ATARS	Automated Traffic Advisory and Resolution Service
ATC	Air Traffic Control
ATCSF	Air Traffic Control Simulation Facility
AWP	Aviation Weather Processor
BAL	Basic Assembly Language
BCD	Binary Coded Decimal
BDAS	Beacon Data Acquisition Systems
CCC	Central Computer Complex
CCIL	Controller-Computer Interface Laboratory
CD	Common Digitizer
CDC	Computer Display Channel
CIDIN	Common ICAO Data Interchange Network
CMC	Communications Multiplexor Channel
CPU	Central Processing Unit
CR/CP	Card Reader/Card Punch
CRJE	Conversational Remote Job Entry
CRT	Cathode Ray Tube
CTS	Coded Time Source
DABS	Discrete Address Beacon System
DARC	Direct Access Radar Channel
DART	Data Analysis and Reduction Tool
DCC	Display Channel Complex
DRE	Data Receiver Equipment
DUAT	Direct User Access Terminals
E&D	Engineering & Development
E-MSAW	En Route Minimum Safe Altitude Warning
EAM	Electronic Accounting Machines
EFAS	En Route Flight Advisory Service
ESSF	En Route System Support Facility
ETABS	Electronic Tabular Display Subsystem
ETG	Enhanced Target Generator
FAA	Federal Aviation Administration
FACO	Facility Control Office
FDB	Full Data Block
FDEP	Flight Data Entry Positions

FEP	Front End Processor
FSDPS	Flight Service Data Processing System
FSS	Flight Service Station
FTS	Federal Telephone System
GPI/GPO	General Purpose Input/Output
ICAO	International Civil Aviation Organization
ICCC	IOP Channel Configuration Controller
IFR	Instrument Flight Rules
IMTU	Integrated Magnetic Tape Unit
INTI/INTO	Interfacility Input/Output
IOCE	Input/Output Control Element
IOP	Input/Output Processor
IOT	Input/Output Typewriter
IP	Interface Processor
LLWSAS	Low Level Wind Shear Alert System
MARS	Maintenance Automotive Reporting System
MDBM	Multiplexor Display Buffer Memories
MPE	Multiprocessor Executive
MVT	Multiprogramming with Variable number of Tasks
NADIN	National Airspace Data Interchange Network
NAFEC	National Aviation Facilities Experimental Center
NAS	National Airspace System
NCSS	NAFEC Communications Switching System
NLSSS	NAFEC Laboratory Signal Switching System
NOSS	NAS Operational Support System
OS	Operating System
OSEM	Office of System Engineering Management
PAM	Peripheral Adapter Module
PCP	Primary Control Program
PIREP	Pilot Reports
PM	Program Management
PVD	Plan View Display
R&D	Research & Development
RBS	Radar Beacon Simulator
RDAS	Radar Data Acquisition System
RFDU	Reconfiguration and Fault Detection Unit
SAR	System Analysis Recording
SLC	Salt Lake City
SMF	System Management Facilities
SRAP	Sensor Receiver and Processor
SRDS	System Research and Development Service
SVSS	Small Voice Switching System
T&A	Technical & Administrative
T&E	Test & Evaluation
TAGS	Tower Automated Ground Surveillance System
TATF	Terminal Automation Test Facility
TCG	Time Code Generator
TDP	Technical Data Package

TFDP	Terminal Flight Data Processor
TIPS	Terminal Information Processing System
TRACON	Terminal Radar Approach Control
TSSF	Terminal System Support Facility
TTL	Transistor/Transistor Logic
UDS	Universal Data Set
VAS	Vortex Advisory System
VICON	Visual Confirmation of Voice Takeoff Clearance
VRS	Voice Response System
VSCS	Voice Switching and Control System
WMSC	Weather Message Switching Center
WWV	Call Letters for Bureau of Standards Radio Station
WX	Communications Symbol for Weather