

AD-A082 798

NAVAL RESEARCH LAB WASHINGTON DC
A PATTERN-SYNTHESIS PROCEDURE FOR REGULAR PLANAR ARRAYS. (U)
FEB 80 J P SHELTON

F/G 20/14

UNCLASSIFIED

NRL-8368

SBIE -AD-E000 386

NL

AD-A082 798

END
DATE
FILMED
5 80
DTIC

12

LEVEL III

ADA 082798

**A Pattern-Synthesis Procedure
for Regular Planar Arrays**

J. PAUL SHELTON

*Target Characteristics Branch
Radar Division*

February 14, 1980

DTIC
ELECTE
APR 8 1980
S B D



NAVAL RESEARCH LABORATORY
Washington, D.C.

Approved for public release; distribution unlimited.

DOC FILE COPY

80 2 22 010

SECURITY CLASSIFICATION OF THIS PAGE (When Data Entered)

REPORT DOCUMENTATION PAGE		READ INSTRUCTIONS BEFORE COMPLETING FORM
1. REPORT NUMBER NRL Report 8368	2. GOVT ACCESSION NO.	3. RECIPIENT'S CATALOG NUMBER
4. TITLE (and Subtitle) A PATTERN-SYNTHESIS PROCEDURE FOR REGULAR PLANAR ARRAYS		5. TYPE OF REPORT & PERIOD COVERED Interim report on a continuing NRL problem number
		6. PERFORMING ORG. REPORT NUMBER
7. AUTHOR(s) J. Paul Shelton		8. CONTRACT OR GRANT NUMBER(s)
9. PERFORMING ORGANIZATION NAME AND ADDRESS Naval Research Laboratory Washington, DC 20375		10. PROGRAM ELEMENT, PROJECT, TASK AREA & WORK UNIT NUMBERS NRL Problem 0604-0 Program Element 62712N Project SF 12141491
11. CONTROLLING OFFICE NAME AND ADDRESS Naval Sea Systems Command Washington, DC 20362		12. REPORT DATE February 14, 1980
		13. NUMBER OF PAGES 17
14. MONITORING AGENCY NAME & ADDRESS (if different from Controlling Office)		15. SECURITY CLASS. (of this report) UNCLASSIFIED
		15a. DECLASSIFICATION/DOWNGRADING SCHEDULE
16. DISTRIBUTION STATEMENT (of this Report) Approved for public release; distribution unlimited.		
17. DISTRIBUTION STATEMENT (of the abstract entered in Block 20, if different from Report)		
18. SUPPLEMENTARY NOTES		
19. KEY WORDS (Continue on reverse side if necessary and identify by block number) Antennas Planar arrays Pattern synthesis Sidelobe control		
20. ABSTRACT (Continue on reverse side if necessary and identify by block number) The synthesis of radiation pattern functions for symmetric hexagonal arrays is considered. The concept of number of degrees of freedom in the array illumination is introduced, and the pattern characteristics of the seven-element array are developed. The relationship between multiplication of pattern functions and convolution of array illuminations is established. Synthesis techniques with zero and one degree of freedom are presented and demonstrated with examples. The technique with zero degrees of freedom generates hexagonal arrays which are analogous to linear arrays with binomial-coefficient illumination.		

DTIC
ELECTE
S APR 8 1980 **D**
B

DD FORM 1473 1 JAN 73 EDITION OF 1 NOV 65 IS OBSOLETE
S/N 0102-014-6601

SECURITY CLASSIFICATION OF THIS PAGE (When Data Entered)

CONTENTS

INTRODUCTION	1
ARRAY AND PATTERN-FUNCTION GEOMETRY	2
PATTERN CHARACTERISTICS OF SEVEN-ELEMENT ARRAYS	5
SYNTHESIS OF PATTERN FUNCTIONS BY CONVOLUTION	9
SYNTHESIS OF PATTERN FUNCTIONS WITH ONE DEGREE OF FREEDOM	12
DISCUSSION	13
ACKNOWLEDGMENT	14
REFERENCES	14

ACCESSION for		
NTIS	White Section	<input checked="" type="checkbox"/>
BDC	Buff Section	<input type="checkbox"/>
UNANNOUNCED		<input type="checkbox"/>
JUSTIFICATION _____		
BY _____		
DISTRIBUTION/AVAILABILITY CODES		
Dist.	AVAIL. and/or	SPECIAL
A		

A PATTERN-SYNTHESIS PROCEDURE FOR REGULAR PLANAR ARRAYS

INTRODUCTION

Of the voluminous literature on antenna-pattern synthesis, essentially all of it is devoted to one-dimensional pattern functions. That is, the pattern function is defined in only one dimension, as is the case for a line-source aperture, or it varies in only the radial dimension, as is the case for an aperture excitation with circular symmetry [1-3]. In the case of a planar array the two-dimensional illumination has generally been assumed to be separable. In a synthesis procedure for hexagonal arrays, Goto has applied the excitation values for a linear array to the hexagonal array [4]. The techniques used for the synthesis of linear-array patterns differ markedly from those used for planar arrays. For the linear array, synthesis usually depends on the control of the zeros of the pattern function. No similar treatment of the zeros of planar-array radiation patterns has been reported.

Iterative computational techniques have been applied increasingly to both linear and planar arrays, and one is tempted to follow the computational rather than the analytical path [5,6]. Nevertheless the paucity of analysis of planar arrays leads us to hope that some analysis will, if nothing more, provide an advantage in the application of the computational iterative procedures.

The general objective in this report is to establish a starting point for the synthesis of radiation patterns from symmetric hexagonal arrays. Before addressing specific objectives, we will introduce a concept which relates the synthesis technique to the number of degrees of freedom available in the array configuration. In general an array of N radiators has $N - 1$ independent complex parameters available in its aperture illumination. This is readily grasped by assigning unit voltage excitation to any one of the elements and allowing the remaining elements to assume independent voltages. In many cases symmetry constraints reduce the number of independent complex parameters available to the designer. For example a symmetric linear array with an even number of elements has $N/2 - 1$ independent complex parameters.

A very general synthesis procedure will use many or even all of the available independent parameters available in a given array. For example, if we wished to specify the far-field complex voltage at N evenly spaced locations, we would make use of all $N - 1$ parameters, and the synthesis procedure would be a Fourier transform. At the other extreme, if we wished to obtain maximum gain from a linear array, there would be no variable parameter in the synthesis procedure: All element voltages are always unity. Another example is the linear array with voltage excitation proportional to the binomial coefficients. This synthesis produces antenna patterns with no sidelobes. Again, once N is specified and the voltage on any element is picked, the voltages on all other elements are automatically determined.

Manuscript submitted October 2, 1979.

SHELTON

We will refer to a general procedure that uses all $N - 1$ parameters as having $N - 1$ degrees of freedom. Procedures with no variable parameters are procedures with zero degrees of freedom. In this report we will derive synthesis procedures for hexagonal arrays which have zero and one degree of freedom. These are intended as starting points for more general procedures with a higher number of degrees of freedom.

ARRAY AND PATTERN-FUNCTION GEOMETRY

Figure 1 illustrates the simplest of the hexagonal arrays treated in this report. The array elements are on a regular triangular lattice. The array excitation coefficients are constrained to be real, positive, and symmetric such that rotation of the array through any multiple of 60° and also mirror imaging through any of the six planes of symmetry leaves the excitation coefficients unchanged. A larger array is formed by adding hexagonal rings of elements to a smaller array. Thus the next larger array after the seven-element array of Fig. 1 contains 19 elements. In general, if the number of elements on one side of the hexagon is $n + 1$, or in other words in the number of hexagonal rings is n , the number of elements in the array is

$$N = 3n^2 + 3n + 1.$$

The elements of the array of Fig. 1 are on an infinite lattice which can be defined by the set of vectors

$$p_{mn} = ma_1 + na_2,$$

$$a_1 = \frac{2s}{\sqrt{3}} x_0,$$

and

$$a_2 = \frac{s}{\sqrt{3}} x_0 + sy_0,$$

where a_1 and a_2 are base lattice vectors, x_0 and y_0 are unit x and y vectors, and m and n are integers.

Because of the symmetry constraints the number of independent parameters is a small fraction of the number of elements in the rings of the array, varying from $1/6$ in the case of the smallest arrays to $1/12$ for a large array. Table 1 lists the number of rings, the number of independent parameters, and the total number of elements for $n = 1$ through 9.

Figure 2 illustrates the grating-lobe pattern for the hexagonal array. The coordinates are proportional to the cosines of the angles to a vector in the direction of plane wavefront propagation, the angles being measured from the x and y axes of Fig. 1. The major lobes (grating lobes for an infinite lattice) are on a regular triangular (hexagonal) lattice, with the main lobe located at O , since the array excitation is in phase, and with grating lobes at O' , O'' , O''' , etc. The coordinates of Fig. 2 are given by

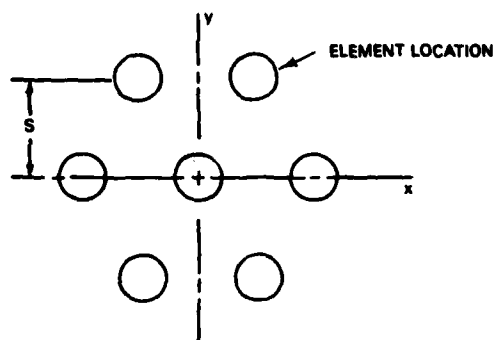

Fig. 1 - Smallest symmetric hexagonal array

Table 1 - Characteristics of Symmetric Hexagonal Arrays

Number of Rings n	Number of Independent Parameters p	Number of Elements N
1	1	7
2	3	19
3	5	37
4	8	61
5	11	91
6	15	127
7	19	169
8	24	217
9	29	271
$2\ell + 1 = n$ odd	$\ell^2 + 3\ell + 1$	$12\ell^2 + 18\ell + 7$
$2(\ell + 1) = n$ even	$\ell^2 + 4\ell + 3$	$12\ell^2 + 30\ell + 19$

$$u_x = \frac{2\pi s}{\lambda} \cos \theta_x$$

and

$$u_y = \frac{2\pi s}{\lambda} \cos \theta_y,$$

where s is the minimum spacing between rows of elements and θ_x and θ_y are the angles from the x and y axes respectively.

SHELTON

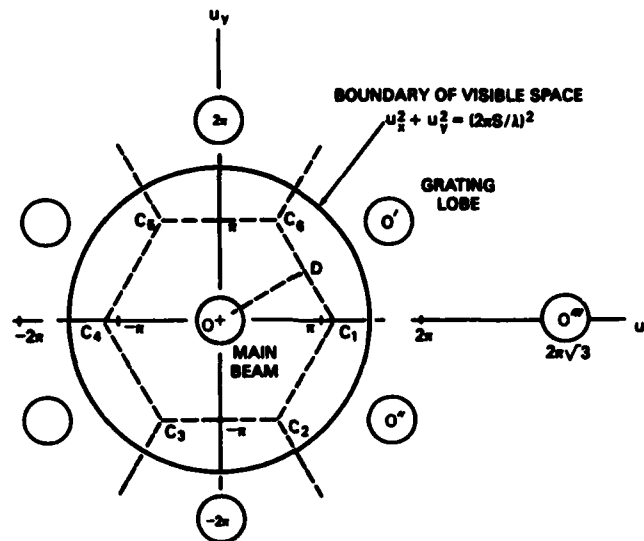

Fig. 2 — Pattern-function representation in the $u_x u_y$ plane

The case treated here is a special case of the classical problem of diffraction from an infinite regular lattice [7]. The results of this analysis can be applied to any regular array lattice through an appropriate affine transformation, as shown by Lo and Lee [8]. However, any other lattice would sacrifice the symmetry of the hexagonal arrays and equilateral triangular lattice analyzed in this report.

The grating-lobe pattern of Fig. 2 has the spatial periodicity of the reciprocal lattice of the antenna-array lattice [9]. The coordinates of the grating lobes are

$$u_x(m) = m\pi\sqrt{3}$$

and

$$u_y(m, n) = 2\pi(n - \frac{m}{2}).$$

The general pattern function for arbitrary excitation has the periodicity of the grating lobes in the $u_x u_y$ plane, and the cell defined by the hexagon $C_1 C_2 C_3 C_4 C_5 C_6$ completely describes the function. Furthermore, with the symmetry constraints which we have placed on the array, 1/12 of the cell, defined by the triangle $OC_1 D$, is sufficient to completely describe the pattern functions with which we are concerned. Also shown in Fig. 2 is a circle defined by $u_x^2 + u_y^2 = (2\pi s/\lambda)^2$, which represents the boundary of visible space. The radius of this circle is directly proportional to s . The synthesis procedures considered here address the hexagonal cell without regard to any limitations imposed by s . That is, pattern functions are synthesized over the entire cell even though part of the cell could be excluded from visible space by appropriate selection of s .

PATTERN CHARACTERISTICS OF SEVEN-ELEMENT ARRAYS

In this section we consider some of the general pattern characteristics of hexagonal arrays before attempting to synthesize pattern functions. We note at the outset that our symmetric arrays generate real pattern functions. This is because the projected-line-source excitation for any plane cut through the center of the array is real and symmetric. Therefore the corresponding voltage pattern function is also real, as well as symmetric. The complete pattern function $E(u_x, u_y)$ is therefore a real function of two variables. It can be visualized as a surface in three-space: (u_x, u_y, E) . The loci of the zeros of $E(u_x, u_y)$ are sets of curves on the $u_x u_y$ plane. This pattern function is not an analytic function of the complex variable $u_x + ju_y$, and this limits the range of mathematical techniques which can be applied to the synthesis problem.

The pattern functions attainable with the seven-element hexagonal array are now considered. For uniform excitation of all elements of the array the pattern function is

$$E(u_x, u_y) = 1 + 4 \cos \frac{u_x}{\sqrt{3}} \cos u_y + 2 \cos \frac{2u_x}{\sqrt{3}}. \quad (1)$$

Figure 3 shows computationally convenient pattern-function cuts through the main lobe: along the x axis, along the y axis, and in the plane containing the line $x = 3\sqrt{3}y$. This last cut is the one for which the projected line source is a uniformly spaced array. The pattern function for this case is obtained by rotating the $u_x u_y$ coordinate system through the angle $\tan^{-1}(\sqrt{3}/9)$. This rotation is accomplished by a rotational transformation from $u_x u_y$ to $u'_x u'_y$, as follows:

$$u_x = u'_x \sin \theta + u'_y \cos \theta \quad (2a)$$

and

$$u_y = u'_x \cos \theta - u'_y \sin \theta, \quad (2b)$$

where $\tan \theta = \sqrt{3}/9$. Setting $u'_y = 0$ and substituting Eqs. (2) into Eq. (1) yields

$$E(u'_x, 0) = 1 + 2 \cos \frac{u'_x}{\sqrt{7}} + 2 \cos \frac{2u'_x}{\sqrt{7}} + 2 \cos \frac{3u'_x}{\sqrt{7}} = \frac{\sin \sqrt{7} u'_x}{\sin \frac{u'_x}{\sqrt{7}}}. \quad (3)$$

Because the u'_x axis intersects cells in different ways, the symmetry of the pattern function allows five subcell cuts to be folded onto a single subcell as shown in Fig. 4. The first three zeros of Eq. (3) fall at point P, with the result that the lengths of line segments OP, PQRP, and PSTP are all equal to $2\pi/\sqrt{7}$ radians and segment PD is $\pi/\sqrt{7}$ radians. The x -axis cut passes through the center of some cells and along the edge of others; therefore it provides

SHELTON

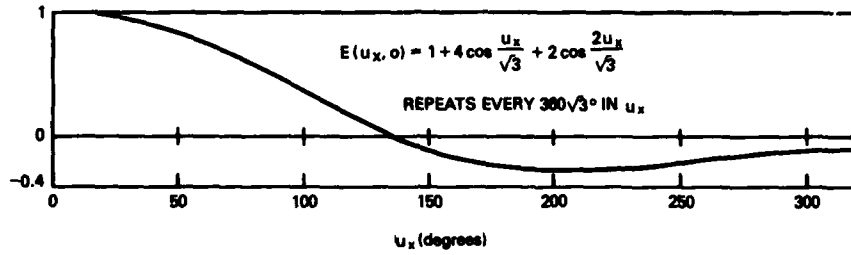

(a) Cut along the x axis

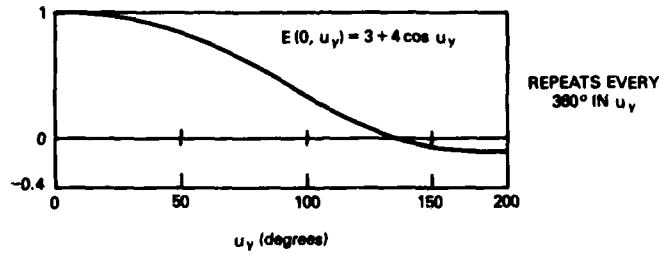

(b) Cut along the y axis

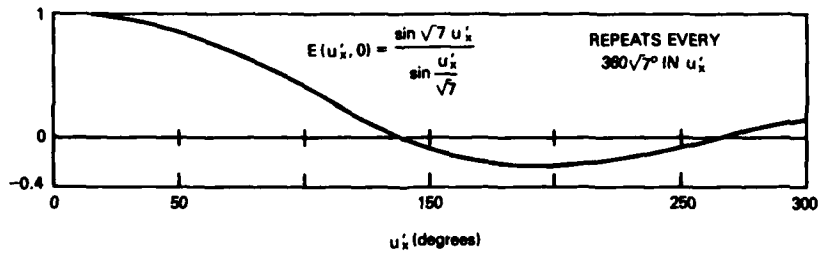

(c) Cut along the line $x = 3\sqrt{3}y$

Fig. 3 — Pattern cuts through the main lobe for a uniformly excited seven-element hexagonal array

SHELTON

Equations (5) and (6) can be examined to establish some limits on the ranges of a which we will investigate. Zeros for real values of u_y are found on the y -axis cuts for $a \geq 1/2$ and $a \leq -1/6$. Zeros are found on the x -axis for $a \geq 1/3$ and $a \leq -1/6$. For $-1/6 < a < 1/3$ the pattern function has no zeros for real u_x or u_y . These restrictions on u_x and u_y are simply due to the pattern function and are unrelated to restrictions on u_x and u_y which result from the boundary of the visible region.

Figure 5 illustrates how the locus of zeros moves with variation in the parameter a . The locus approaches O as $a \rightarrow -1/6$ from below, and it approaches C_1 as $a \rightarrow 1/3$ from above. It can be shown that for a near $-1/6$ ($a = -(1/6) - \epsilon$)

$$u_x \approx u_y \approx 3\sqrt{2\epsilon} \text{ (in radians)} \quad (7)$$

and that for a near $1/3$ ($a = 1/3 + \delta$)

$$\Delta u \approx \pm 3\sqrt{\delta}, \quad (8)$$

where $u_x = 2\pi\sqrt{3} + \Delta u$. Equations (7) and (8) indicate that the locus of zeros becomes circular in the neighborhoods of O and C_1 .

Other characteristics of the pattern function which are of interest and easily determined are the pattern values at C_1 and D . The pattern values at O , C_1 , and D are

$$E_O = 1 + 6a, \quad (9a)$$

$$E_{C_1} = 1 - 3a, \quad (9b)$$

and

$$E_D = 1 - 2a. \quad (9c)$$

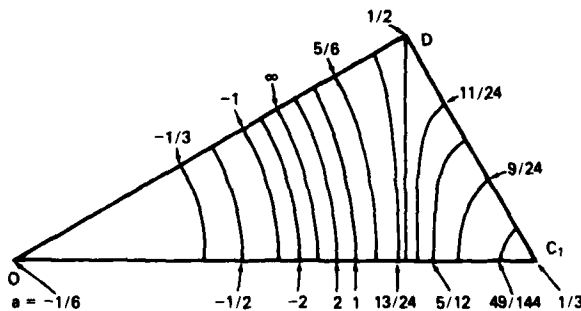

Fig. 5 — Locus of zeros for various values of a

NRL REPORT 8368

The absolute pattern values at C_1 and D are the same and equal to -24.61 dB for $\alpha = 0.4$. It was previously stated that the pattern function is a surface in the three-space (u_x, u_y, E) . For $\alpha = 1/3$ this surface becomes tangent to the $E = 0$ plane at C_1 and all similar points. For this case the pattern value at D is -19.08 dB.

SYNTHESIS OF PATTERN FUNCTIONS BY CONVOLUTION

We now consider hexagonal arrays larger than the seven-element array analyzed in the previous section. Since the relationship between pattern function and array excitation is a Fourier transform, the array excitation for a product of pattern functions is the convolution of the array excitations of the individual pattern functions. The generation of the binomial distribution is an example of this procedure.

For the linear array the simplest pattern function which places a zero midway between adjacent grating lobes is

$$E(u) = \cos \frac{u}{2}, \quad (10)$$

which is obtained from a two-element array with equal excitation. The array illumination is given mathematically by

$$A(x) = \delta(-\frac{d}{2}) + \delta(\frac{d}{2}), \quad (11)$$

where d is the element spacing and $\delta(a)$ is the Dirac delta function at $x = a$. Consider Eq. (10) to be the first pattern function in a set given by

$$E_n(u) = (\cos \frac{u}{2})^n. \quad (12)$$

The array illumination for $E_n(u)$ is obtained recursively by convolving the array illumination for $E_{n-1}(u)$ with Eq. (11). For example the array illumination for $n = 2$ is

$$A_2(x) = \delta(-d) + 2\delta(0) + \delta(d).$$

Thus the array illuminations for Eq. (12) are $n + 1$ element arrays with amplitudes corresponding to the binomial coefficients.

Another way of looking at this process, from an antenna point of view, is to consider that each element of an array is being replaced by an array. For example, if the array is $\delta(-d/2) + \delta(d/2)$, then each of these elements is replaced by an array, one being $\delta(-d) + \delta(0)$ and the other $\delta(0) + \delta(d)$, and the resulting array is $\delta(-d) + 2\delta(0) + \delta(d)$.

SHELTON

This convolution procedure can be analogously extended to planar arrays for the synthesis of pattern functions. For example the pattern function for a symmetric seven-element array can be expressed as $E(u_x, u_y, a)$, from Eq. (4). For a larger hexagonal array the pattern can be defined as

$$E_n(u_x, u_y, a) = [E(u_x, u_y, a)]^n. \quad (13)$$

The convolution procedure for obtaining the array illumination for the pattern function given by Eq. (13) for $n = 2$ and $a = 1/3$ is illustrated in Fig. 6. The initial array illumination has been multiplied by 3 to make all amplitudes integer-valued.

The hexagonal array for $a = 1/3$ is directly analogous to the linear array with binomial-coefficient illumination in that both have pattern function with zeros as far from the grating lobes as possible. The array illuminations resulting from the first four convolutions are shown in Fig. 7. To conserve space, Fig. 7b, 7c, and 7d contain only 1/12 of the array, which by symmetry defines the entire illumination. This is the synthesis procedure for hexagonal arrays which have zero degrees of freedom. Once we have selected n , or in effect the number of elements in the array, we have determined the array illumination. In addition

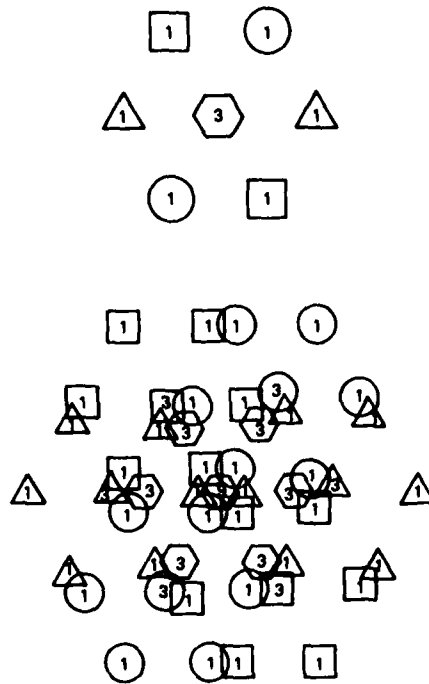

Fig. 6 - Generation of a 19-element array by replacing each element of a seven-element array with a seven-element array ($a = 1/3$)

NRL REPORT 8368

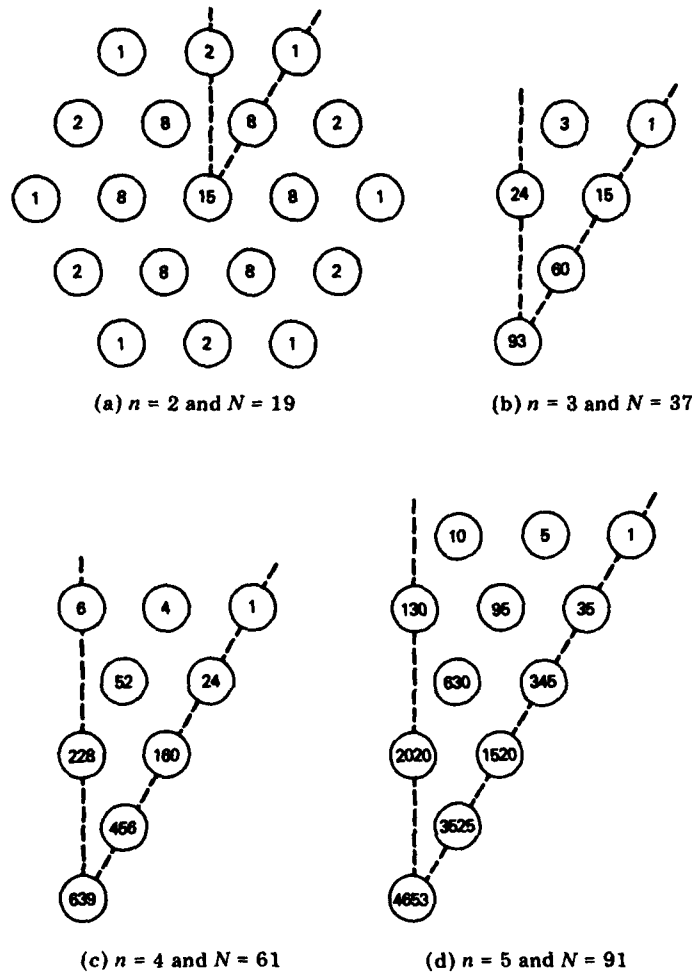

Fig. 7 — Array excitations for $n = 2$ through 5 for $a = 1/3$

to locating all zeros at the corners of the pattern-function cells as defined in Fig. 2 (point C_1 and all similar points), these arrays produce pattern levels at the midpoints of the sides of the cells (such as point D) which are given by

$$|E_n(D, a = 1/3)/E_n(O, a = 1/3)|^2 = -16.90n \text{ dB},$$

where n is the number of hexagonal rings in the array.

SHELTON

The generation of linear arrays with illuminations equal to the binomial coefficients is directly related to Pascal's triangle, in which each number in any given row is obtained by adding the two numbers in the row above to the right and left of the given number. Analogously we can generate a pyramid of numbers, each layer of which is the appropriate illumination for a hexagonal array with $a = 1/3$. The generating algorithm for these Pascal-like pyramids is as follows: The value of an element is the sum of three times the value of the element directly above in the layer above and the values of the six next-nearest elements in the layer above. The pyramid has six sides, each of which is a Pascal triangle.

SYNTHESIS OF PATTERN FUNCTIONS WITH ONE DEGREE OF FREEDOM

In the synthesis procedure described in the preceding section, the pattern function was defined by Eq. (13) with $a = 1/3$. It is apparent that the number of degrees of freedom in the synthesis procedure can be increased from zero to one by allowing a to assume other values.

From Eqs. (9) the power levels at points C_1 and D relative to the level at point O are given for the seven-element array by

$$P_{C_1}(a) = \left| \frac{1-3a}{1+6a} \right|^2$$

and

$$P_D(a) = \left| \frac{1-2a}{1+6a} \right|^2.$$

For larger hexagonal arrays, in which the array illumination is obtained by multiply convolving the illumination of the seven-element array, the power levels are given by

$$P_{C_1}(a, n) = \left| \frac{1-3a}{1+6a} \right|^{2n} \quad (14a)$$

and

$$P_D(a, n) = \left| \frac{1-2a}{1+6a} \right|^{2n}, \quad (14b)$$

where n is again the number of hexagonal rings in the array.

A straightforward one-parameter synthesis procedure for specified sidelobe level can be carried out using Eqs. (14). Once the size of the array is specified, the maximum allowable power level at point C_1 or D is selected, and the value of a is determined from which-

ever of Eqs. (14) gives the larger power level. As an example, for $n = 3$ and a maximum power level of -28.63 dB ($-20 \log 3^3$), it is found from the equation for P_{C_1} that $a = 4/15$ and $4/3$; and it is found from the equation for P_D that $a = 1/6$ and ∞ . Figure 5 shows that for $a = 1/6$ and $4/15$ the pattern function has no zeros. Therefore these solutions are set aside for the moment. For $a = \infty$, $P_{C_1} = -18.06$ dB; so this solution is rejected. For $a = 4/3$, $P_D = -43.94$ dB; and this is the desired solution. The array illumination for this case is obtained by convolution, and the amplitudes of the elements in $1/12$ of the 37-element array are shown in Fig. 8a.

This synthesis procedure produces the designed power level or less at the edges of the hexagonal pattern function cell ($C_1 C_2 C_3 C_4 C_5 C_6$ in Fig. 2). The synthesis is applicable provided that the designed power level is no less than $-24.61n$ dB.

Array illuminations are also shown in Fig. 8 for 19-element and 61-element arrays for the design requirement of -28.63 dB maximum power level at the edge of the pattern cell. In each case a different value of a is found, and, as was indicated, a seven-element array with this power level cannot be synthesized.

DISCUSSION

As was stated in the introduction, the objective in this report has been to establish a starting point for pattern synthesis of hexagonal arrays. The synthesis procedures described here have relied on pattern multiplication and corresponding convolution of array illuminations. Pattern-function control has been achieved only at the edge of the hexagonal pattern-function cell.

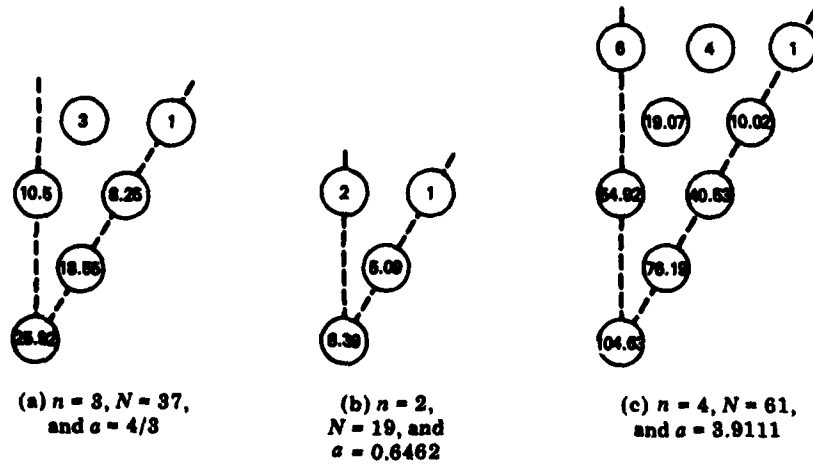

Fig. 8 — Array illuminations for a power level <-28.63 dB ($-20 \log 3^3$) at the edge of a pattern cell

SHELTON

The procedure with zero degrees of freedom generates a set of pattern functions which have zero values only at the corners of the pattern cells. Figure 7 shows that the array illuminations for this case are strongly tapered (56.1 dB from center to corner for the 61-element array), and the practical utility of such arrays is minimal.

The procedure with one degree of freedom allows us to specify a maximum power level at the edge of the pattern function. In addition to the added degree of pattern control, the array illuminations for this case are less strongly tapered than in the procedure with zero degrees of freedom. However, the illumination taper is still sufficiently large (40.4 dB from center to corner for the 61-element array in the example) and the degree of pattern control is sufficiently small that this procedure will not find significant practical application either.

However, the synthesis techniques described here do represent a starting point for the development of more powerful procedures, and it is expected that more general procedures with a larger number of degrees of freedom will evolve from these concepts.

ACKNOWLEDGMENT

I thank Dr. Walter K. Kahn for his painstaking and thorough review of the initial draft of this paper and for his constructive and helpful suggestions. He supplied the expressions for p and N in terms of l given in Table 1.

REFERENCES

1. C.L. Dolph, "A current distribution for broadside arrays which optimizes the relationship between beam width and side-lobe level," Proc. IRE, 34, 335-348 (June 1946).
2. T.T. Taylor, "Design of line-source antennas for narrow beamwidth and low side-lobes," IRE Trans. Antennas Propagat. AP-3, 16-28 (Jan. 1955).
3. T.T. Taylor, "Design of circular apertures for narrow beamwidth and low side lobes," IRE Trans. Antennas Propagat. AP-8, 17-22 (Jan. 1960).
4. N. Goto, "Pattern synthesis of hexagonal planar arrays," IEEE Trans. Antennas Propagat. AP-20, 479-481 (July 1972).
5. O. Einarsson, "Optimization of planar arrays," IEEE Trans. Antennas Propagat. AP-27, 86-92 (Jan. 1979).
6. R.R. Kurth, "Optimization of array performance subject to multiple power pattern constraints," IEEE Trans. Antennas Propagat. AP-22, 103-105 (Jan. 1974).

NRL REPORT 8368

7. L. Brillouin, *Wave Propagation in Periodic Structures*, 2nd edition, New York, Dover, 1953, pp 94-96.
8. Y.T. Lo and S.W. Lee, "Affine transformation and its application to antenna arrays," *IEEE Trans. Antennas Propagat.* AP-13, 890-896 (Nov. 1965).
9. W.K. Kahn, "Ideal efficiency of a radiating element in an infinite array," *IEEE Trans. Antennas Propagat.* AP-15, 534-538 (July 1967).