

AD-A082 833

NATIONAL RESEARCH COUNCIL OF CANADA OTTAWA (ONTARIO) --ETC F/6 17/6
QUARTERLY BULLETIN OF THE DIVISION OF MECHANICAL ENGINEERING AN--ETC(U)
1979

UNCLASSIFIED

DME/NAE-1979(4)

NL

101
208.882

JUL
JUL
JUL
JUL

END
SER
FILMED
5 80
DTIC

ADA 082833

111 REPORT NO. DME/NAE -1979(4)

LEVEL

122



National Research Council Canada

Conseil national de recherches Canada

12

111-2011

6

QUARTERLY BULLETIN

OF THE

DIVISION OF MECHANICAL ENGINEERING

AND THE

NATIONAL AERONAUTICAL ESTABLISHMENT

...EMENT A
... release;
... Limited

DTIC
APR 9 1980

OTTAWA

1 OCTOBER TO 31 DECEMBER 1979

80 4 7 125

ISSN 0047-9055

The Quarterly Bulletin of the Division of Mechanical Engineering and the National Aeronautical Establishment will cease publication effective with this issue 1979(4).

The National Aeronautical Establishment will be publishing an annual 'Activities Report' which you will receive automatically. This publication will consist of reports from each Laboratory within the Establishment with a list of publications suitable for distribution. This 'Activities Report' will be printed in separate issues of English and French.

A Questionnaire will be included in the Activities Report should you wish to update your mailing list.

The Division of Mechanical Engineering will continue to publish its annual 'Research and Development Report' and the 'Engineering Newsletters' describing separate facilities and programs. The Research and Development Report for 1979 is now being prepared. If you have not been a recipient of this report in the past, it is available without charge on request. The Division of Mechanical Engineering annual Research and Development Report and the Engineering Newsletters are available in English and French.

FOREWORD

The Quarterly Bulletin is designed primarily for the information of Canadian industry, universities, and government departments and agencies. It provides a regular review of the interests and current activities of two Divisions of the National Research Council Canada:

→ Division of Mechanical Engineering
National Aeronautical Establishment

Some of the work of the two Divisions comprises classified projects that may not be freely reported and contractual projects of limited general interest. Other work, not generally reported herein, includes calibrations, routine analyses and the testing of proprietary products.

Comments or enquiries relating to any matter published in this Bulletin should be addressed to: *DME/NAE Bulletin, National Research Council Canada, Ottawa, Ontario, K1A 0R6*, mentioning the number of the Bulletin.

Unannounced Justification		<input checked="" type="checkbox"/>
By		
Distribution/		
Availability Codes		
Dist	Availability	
A		

AVANT-PROPOS

Le Bulletin trimestriel est conçu en premier lieu pour l'information de l'industrie Canadienne, des universités, des agences et des départements gouvernementaux. Il fournit une revue régulière des intérêts et des activités actuelles auxquels se consacrent deux Divisions du Conseil national de recherches Canada:

Division de génie mécanique
Établissement aéronautique national

Quelques uns des travaux des deux Divisions comprennent des projets classifiés qu'on ne peut pas rapporter librement et des projets contractuels d'un intérêt général limité. D'autres travaux, non rapportés ci-après dans l'ensemble, incluent des étalonnages, des analyses de routine, et l'essai de produits de spécialité.

Veillez adresser tout commentaire et toute question ayant rapport à un sujet quelconque publié dans ce Bulletin à: *DME/NAE Bulletin, Conseil national de recherches Canada, Ottawa, Ontario, K1A 0R6*, en faisant mention du numéro du Bulletin.

APPROVED FOR PUBLICATION By _____ Date _____ Distribution Unlimited
--

CONTENTS :

	Page
Foreword	(i)
Illustrations	(iv)
NAE Convair 580 Aeromagnetism Program ; C.D. Hardwick	1
Urban Traffic Signal Control for Fuel Economy ; G.S. Messenger, D.B. Richardson, P.W.U. Graefe, I.H. Mufti	17
Current Projects of the Division of Mechanical Engineering and the National Aeronautical Establishment:	
Analysis Laboratory	45
Control Systems and Human Engineering Laboratory	47
Engine Laboratory	49
Flight Research Laboratory	51
Fuels and Lubricants Laboratory	53
Gas Dynamics Laboratory	54
High Speed Aerodynamics Laboratory	56
Hydraulics Laboratory	58
Low Speed Aerodynamics Laboratory	60
Low Temperature Laboratory	62
Marine Dynamics and Ship Laboratory	63
Railway Laboratory	65
Structures and Materials Laboratory	67
Unsteady Aerodynamics Laboratory	69
Western Laboratory (Vancouver)	70
Publications	71
Proprietary Projects during 1979	75

CONTENTS (Cont'd)

ILLUSTRATIONS

Figure No.		Page
NAE CONVAIR 580 AEROMAGNETICS PROGRAM		
1	Amplitude Responses, Low Frequency Component	2
2	Time Alignment of Data to Complementary Filter	4
3	Complementary Filter Mechanization	4
4	Calculation of Gradient Components	6
5	Gradient Compensation for a Wingtip Magnetometer	8
6	Real Vs Reconstructed DLD	9
7	Post-Flight Compensation (Stb'd Mag)	12
8	In-Flight Compensation	13
9	In-Flight Compensation (High Gradient Area)	13
URBAN TRAFFIC SIGNAL CONTROL FOR FUEL ECONOMY		
1	Test Route — Laurence Ave. East	35
2	Fifth Wheel Attached to "Floating Car"	36
3	Data Flow Schematic	37
4	Velocity Profile of Lawrence Ave. W/B	38
5	Velocity Profile of Lawrence Ave. E/B	39
6	Velocity Profile of Lawrence Ave. E/B	40
7	Velocity Profile of Lawrence Ave. W/B	41
8	Mean Values of Time, Fuel, Stops and Delay	42
CURRENT PROJECTS		
	Test Vehicle for Aerodynamic and Performance Studies of Automotive Cooling System Components	48
	An Advanced Cockpit Control Configuration which is Being Evaluated in Flight Using the NAE Airborne V/STOL Simulator	52

CONTENTS (Cont'd)

ILLUSTRATIONS (Cont'd)

	Page
CURRENT PROJECTS (Cont'd)	
Preparing to Fasten Strain Gauges to a Bridge in the Roger's Pass Area	66
Recordings of Strain were Taken While Bridge was Loaded with a Moving Freight Train	66

NAE CONVAIR 580 AEROMAGNETICS PROGRAM

C.D. Hardwick

High Speed Aerodynamics Laboratory

National Aeronautical Establishment

OBJECTIVES

A current major objective of the NAE aeromagnetism program is the development of equipment aboard the Convair 580 aircraft to provide what is believed to be the first three-axis, total field, airborne gradiometer. This gradiometer configuration offers a number of advantages:

- Enhancing anti-submarine warfare (ASW) capabilities.
- It allows an "array sensing" approach that would give, among other things, information as to a target's position with respect to aircraft track.
- Continuous computation of the earth's field gradient allows the ultimate in manoeuvre noise compensation in that the interference caused by aircraft manoeuvring in a non-zero gradient can be modeled and cancelled on-line.
- For geophysical surveying, the vertical gradient component is of considerable interest to geologists in that it increases the resolution of close sub-surface features while rejecting deep, distant features which are of less interest.
- Also for geophysical surveying, measurement of total field gradient in the across-track direction should allow wider separation between flight lines because this information can be used in the final map contouring programs. It should also reduce the number of tie lines at right angles to the main survey lines needed to complete a magnetic map.
- In achieving the three axis gradiometer objective, there are several complementary sub-objectives to be realized, with respect to geophysical work. There are:
 - Demonstration that a rather simple strap-down cesium magnetometer, in conjunction with good interference compensation, is a satisfactory element in a gradiometer system, in place of the more complex and expensive oriented type of cesium magnetometer.
 - Increasing the accuracy of a strap-down vector magnetometer (a necessary element in the compensation system) to the point where, in conjunction with the aircraft's navigation systems, it will produce useful data on magnetic variation and dip angle. (This type of information is usually obtained using an aircraft with very specialized equipment*.)

The longer term objective for the NAE aeromagnetic R&D project is the evaluation and further development of certain advanced anomaly recognition algorithms, which would be run in real-time in the central processor of the Convair 580.

The results of the aeromagnetic program are made available to Canadian industry on a fairly continuous basis and may be used, for example, for future improvements in long range patrol aircraft. The developments relating to geophysical survey are being monitored by several airborne equipment manufacturers.

* The development of the accurate strap-down magnetometer is also being carried out for DREO, as an element for an advanced strap-down inertial navigation system.

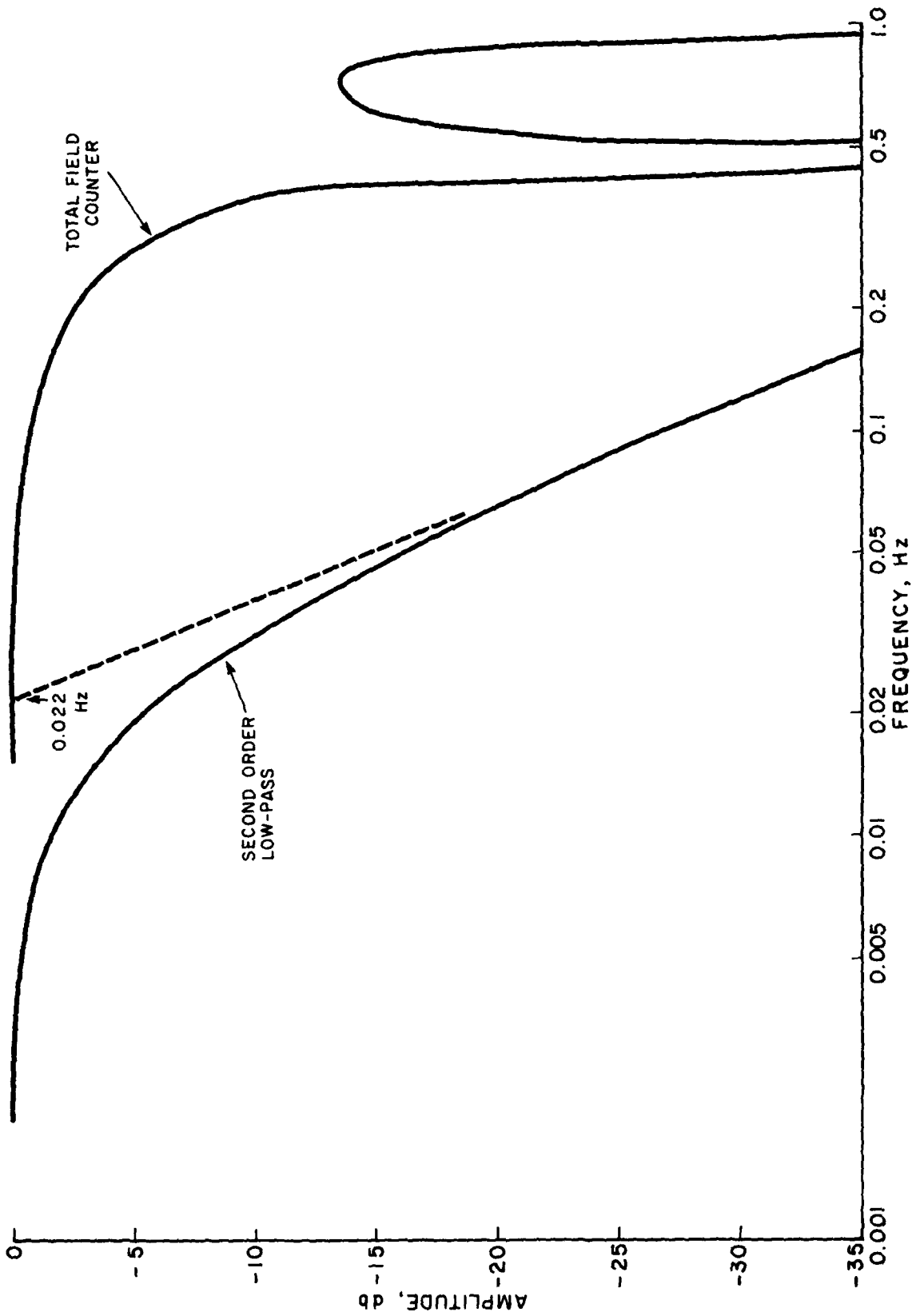

FIG. 1: AMPLITUDE RESPONSES, LOW FREQUENCY COMPONENT

MECHANIZATION OF THE THREE-AXIS GRADIOMETER SYSTEM

MAD* Complementary Filter

In order to measure gradient, it is essential to know the steady-state or "DC" value of the total magnetic field as seen by each of the three magnetometers. Since optically pumped cesium magnetometers produce a frequency proportional to total field (approx. 3.5 Hz/ γ), measurement to the baseline resolution of 0.01 γ can be achieved by a small amount of frequency multiplication and then counting. Frequency counting is not, however, without its difficulties; since it is essentially a digital sampling process, it is subject to aliasing errors from any noise occurring at frequencies anywhere above half the sampling frequency. There are always significant periodic noise contributions from aircraft power (400 Hz) and, as is the case for the Convair, from the propellers which can give as much as 5 γ at a frequency of 17 Hz. Increasing the counting period is an effective way of causing the aliasing effects to be "averaged out", but with a long counting period, the required bandwidth of 0 to 1.2 Hz is not available.

In the Convair system, these counting problems have been overcome by means of a complementary filter approach. One input to the filter is "total field" as measured by a two-second counter, a long enough counting period to ensure immunity from high frequency noise components. The other input is the analog signal from a delay line discriminator (DLD), high-passed at a nominal break frequency of 0.022 Hz and suitably lowpass filtered to remove aliasing noise before being digitized. This second input provides the required high frequency components, while the first input provides a low frequency baseline.

In a complementary filter, an appropriate filter transfer function is applied to each signal so that the summed (or "blended") output has uniform amplitude and phase response over the required frequency band, which in this case is 0 to 1.2 Hz. These filter transfer functions normally take into account the inherent frequency response of the respective input signals. However, in the case total field counter, the response is

$$G(f) = \frac{\sin \frac{2\pi fT}{2}}{2\pi fT/2}$$

where T is the sampling period of 2 seconds. As can be seen from Figure 1, this would be a rather difficult function to handle by simple time domain methods. For this reason, the approach has been to construct the complementary filter using a second order low pass and a second order high pass respectively, with the natural frequency of each set at 0.022 Hz. Thus, the higher frequency components of the counter, although not accounted for analytically, are effectively attenuated. The inherent response of the DLD signal, normally a high pass at 0.022 Hz, is easily taken into account in the design of the high pass section of the complementary filter.

The complementary filter has been mechanized digitally and to get the necessary parameter flexibility, a data stream of 8 Hz, corresponding to the DLD sampling rate, was used. To achieve this data rate for the low frequency side, linear interpolation between the 2 second data points was employed, which leads to a 2 second delay at the blended output. A further delay of one second is required because the output of the total field counter is actually valid for a time corresponding to half way through its sampling period as shown in Figure 2.

* "MAD", for "Magnetic Anomaly Detection" is often used synonymously for "Aeromagnetic Detection".

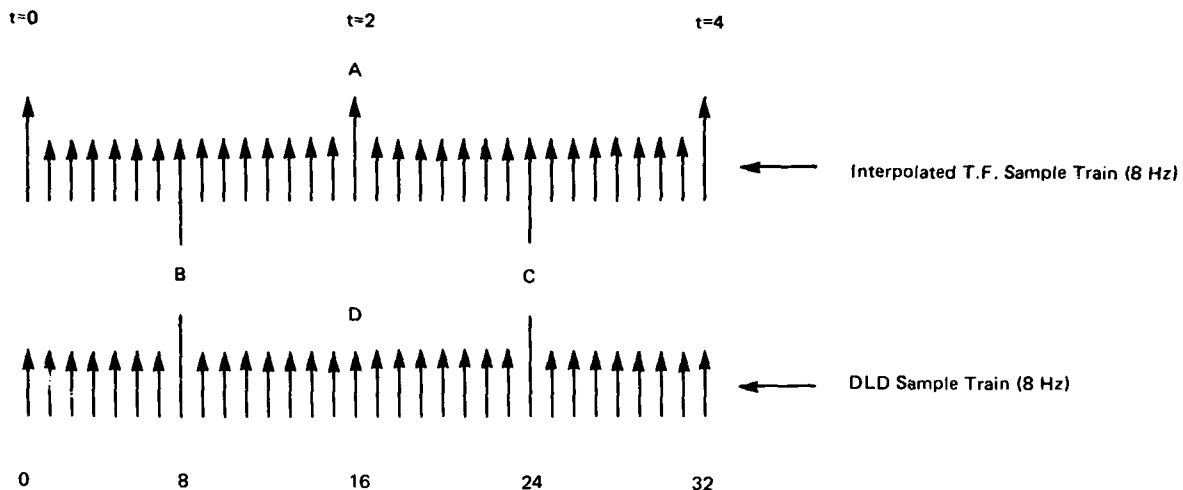

FIG. 2: TIME ALIGNMENT OF DATA TO COMPLEMENTARY FILTER

Note that first interpolated data are available at time A (2 sec) and the interpolated sample at time A will be valid for time B (1 sec) or the 8th sample in the DLD train. Thus, the filter will be started with the interpolated Total Field value and with the DLD sample from B. The start of filtering must be held off until time C (3 sec) to ensure that when the process has advanced to time D in the DLD train, there will be a corresponding interpolated sample available in the other train. The figure shows that although the effective delay of the DLD samples is 3 seconds, only 2 seconds worth of back samples need to be retained.

A schematic representation of the complementary filter with transfer functions in continuous form analog notation is shown in Figure 3.

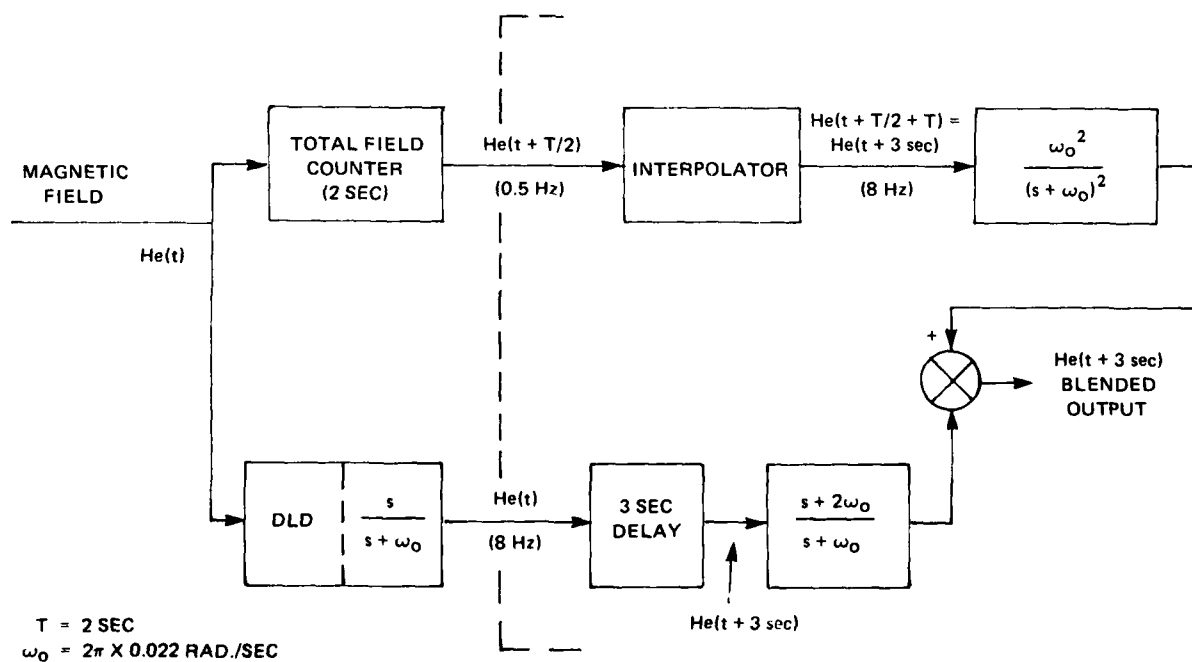

FIG. 3: COMPLEMENTARY FILTER MECHANIZATION

The high frequency (DLD) component is

$$\text{He}(s) \cdot \frac{s}{s + \omega_0} \cdot \frac{s + 2\omega_0}{s + \omega_0} = \text{He}(s) \cdot \frac{s^2 + 2\omega_0 s}{(s + \omega_0)^2}$$

To this is added the low frequency component to give

$$\text{He}(s) \cdot \frac{\omega_0^2}{(s + \omega_0)^2} + \text{He}(s) \cdot \frac{s^2 + 2\omega_0 s}{(s + \omega_0)^2} = \text{He}(s) \cdot \frac{s^2 + 2\omega_0 s + \omega_0^2}{(s + \omega_0)^2} = \text{He}(s)$$

which is the required complementary filter result.

Magnetic Compensation

To make full use of the resolution available from a cesium magnetometer, compensation for the magnetic effects of the aircraft is of prime importance. Basically, an 18-term interference model is used for each magnetometer, the coefficients for which have been pre-computed using an advanced regression technique (Ref. 1). Compensation signals are generated and applied to the digitized magnetometer DLD signals as shown in Figure 4. The compensation and complementary filtering is shown in some detail for one channel (port) within the large dash-marked frame, while that for the other two channels is shown within dash-marked frame, while that for the other two channels is shown within dash-marked boxes. In the digital area to the right of the A/D interface, all elements outside the dash marks are common to all three channels. On the sensor side of the interface, all sensors common to all three channels are shown with a solid triangle mark.

The blended magnetometer signals from the complementary filters are further compensated for possible high frequency residuals from the first compensation and for low frequency interference components in the signals from the total field counters, the latter including a "DC" term that eliminates common-mode signals between the magnetometer pairs. (Several methods for determining the DC terms are currently being investigated and are beyond the scope of this description.) Except for the DC term, these residuals are not expected to be significant and may possibly be combined with the terms from the first set of compensation terms to anticipate the residuals before they occur.

Another approach to the mechanization of compensation signals is the use of orthogonal coils that apply the compensation directly to the magnetometers in the form of fields, in a manner similar to the original CAE FACS system (Ref. 2). We have tended to stay away from this method because of experience with earlier systems in which there was always uncertainty about the orthogonality and scale factors of the coils that required iterative solutions (i.e. more than one set of manoeuvres) to arrive at optimum coefficients. However, if the uncertainties could be resolved, the coil method would allow higher signal resolution before digitization, since dynamic range requirements would be reduced because interference components would no longer be present in the MAD signal. The "DC" terms could also be applied directly, thus eliminating a certain amount of 3-second delay software. One magnetometer (port) is equipped with a set of compensation coils and experiments will be carried out with the coil method once the gradiometer system becomes more mature. As a necessary prelude to such experiments, a method of computing orthogonality errors in the coils, presently being formulated, would have to be validated.

The compensation system for the gradiometer array assumes that the spatial change of total field gradient (i.e. its first derivative) is constant with respect to the spatial amplitude of aircraft manoeuvres. Examination of magnetic maps tends to confirm this assumption. However, if the gradiometers do display significant second order manoeuvre-related effects in high geology areas, another level of compensation will be developed.

Computation of Gradient

When all compensations to the magnetometers have been applied, the lateral and vertical gradient quantities in the airframe axes, Γ_y and Γ_z , can be calculated by differencing, as shown in Figure 4. The vertical gradient is taken to be the difference between the tail magnetometer and the average of the two wingtip magnetometers. (The averaging is not shown explicitly.)

For submarine detection, the gradient quantities would be required in the local level axis frame and in addition, for geological survey work, they would be required in local level rotated into some geographic reference frame, possibly magnetic north. Thus, the last stage of the computation is the resolution of the gradient components into Γ_{NORTH} , Γ_{EAST} and $\Gamma_{VERTICAL}$. It should be noted that the longitudinal component of gradient, Γ_x , is available from any one of the DLD signals if the latter is divided by a linear function of groundspeed (V_x), but for the final axis transformation, it must be delayed by three seconds to match it to the output of the complementary filters. Furthermore, Γ_z is always the most delayed member of the gradients because the tail magnetometer is always following 42 feet behind the windtip magnetometers.[†] Thus, in the final resolver, Γ_x and Γ_y have to be subjected to another slight groundspeed-dependent delay, shown as τ , to match Γ_z .

It is conceivable that in some geological survey applications, the final resolution of gradient into a geographical reference frame would be done post-flight after refinement and smoothing of navigation and track recovery data.

Compensation for Single Magnetometer Sensing

For submarine detection in reasonably geologically quiet areas (i.e. deep water), a single magnetometer will provide greater initial detection range than a gradiometer, since generally speaking, a magnetometer signal from a dipole source falls off inversely as the third power of distance, while a gradiometer signal is proportional to the inverse fourth power.

For single magnetometer detection, the DLD signal is compensated for aircraft magnetic interference in much the same way that has been shown for the gradiometers; in fact, much of the circuitry and computation would be common. However, motion of the aircraft resulting in translation of a single magnetometer in the earth's field gradient should be compensated (Ref. 3). (For magnetometer pairs used as gradiometers, this type of interference is cancelled out.)

The elements necessary for gradient compensation are a) knowledge of the gradient (measured in aircraft axes) and b), a measurement (in aircraft axes) of the displacement of the magnetometer being compensated. From the previous section, it can be seen that Γ_x , Γ_y and Γ_z are the required gradient quantities and there are a number of possible combinations of sensor signals from which can be computed very accurate displacement signals. General sensor arrangements for gradient compensation are shown in Reference 3 and a scheme for the Convair is given below.

Figure 5 shows body-axis doppler velocities (V_y & V_z) used in conjunction with body-axis accelerations (a_y & a_z)* to derive the translational velocities of a wingtip magnetometer. To these translational velocities are added rotational components of velocity (V_{Ry} & V_{Rz}) which are simply linear functions of attitude angles and the respective lever arms from aircraft centre of gravity to the magnetometer. The combined velocity signals are integrated to give magnetometer displacements. The highpass filters match the inherent highpass of the DLD signal and have the advantage of removing any biases that may get integrated over time. The high-passed displacement signals are multiplied with the appropriate body-axis gradient quantities to form the required gradient compensation signals.

Gradient compensation has not been shown for longitudinal in-band displacements because the longitudinal inertia of large aircraft is usually sufficiently high that displacement perturbations in this axis are negligible.

[†] e.g. for 200 Kn groundspeed, the delay would be 0.124 sec or almost exactly one 8 Hz sampling period.
* Measured at the nominal aircraft centre of gravity (CG).

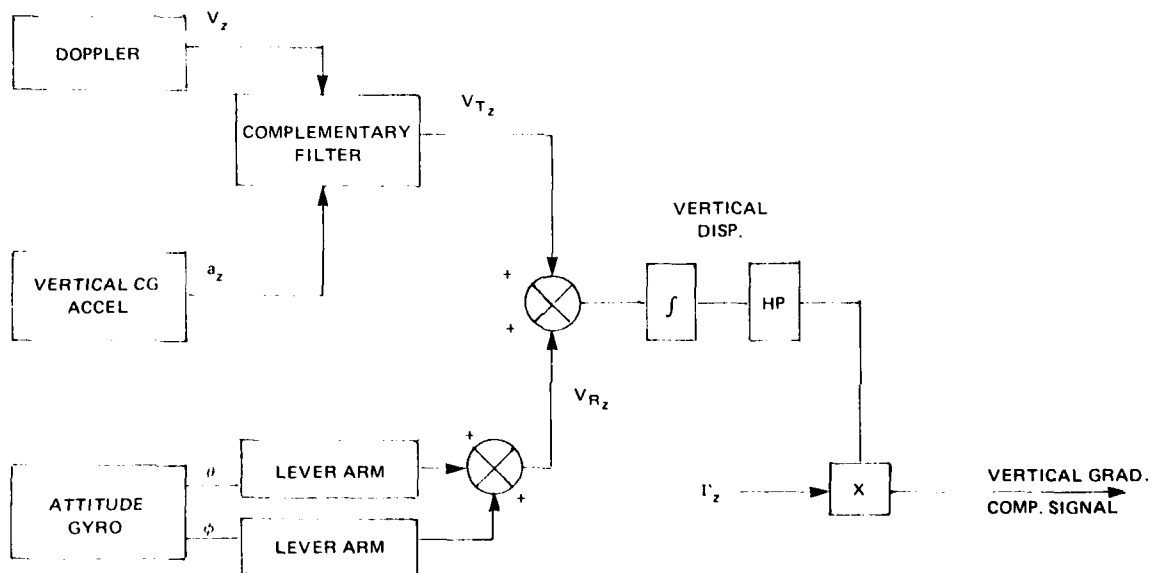
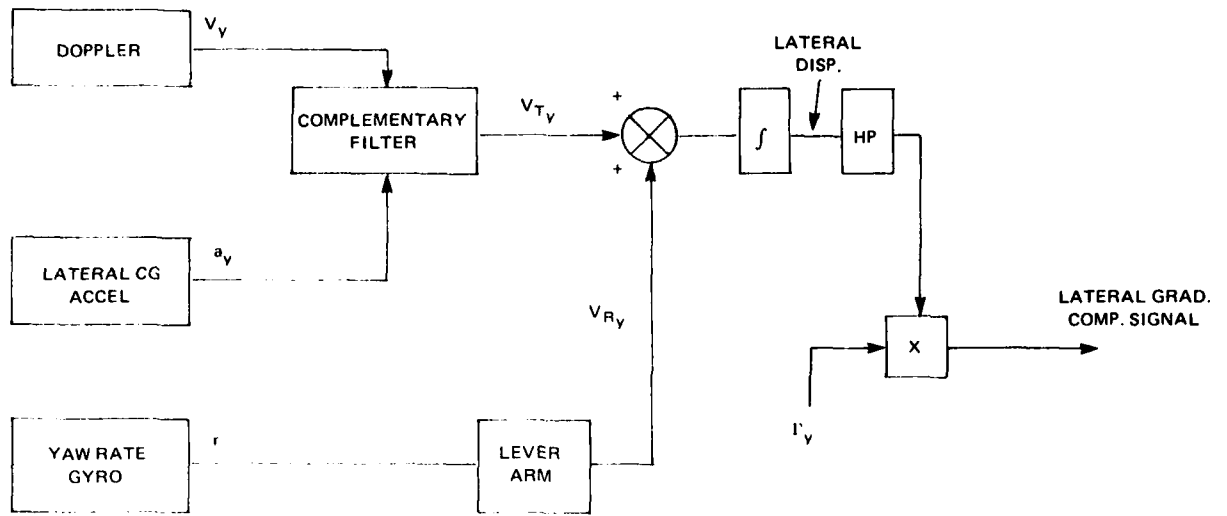

FIG. 5: GRADIENT COMPENSATION FOR A WINGTIP MAGNETOMETER

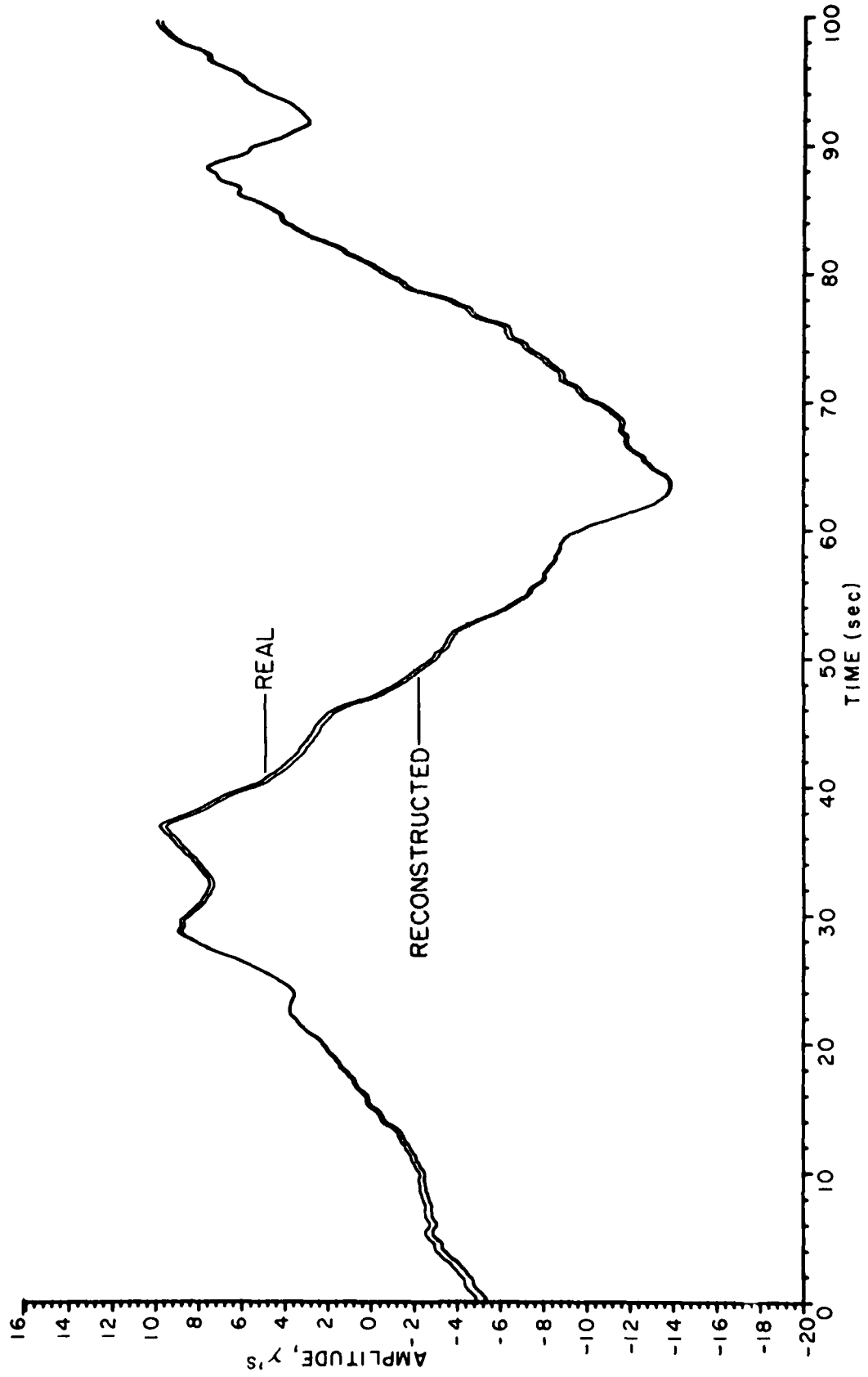

FIG. 6: REAL VS RECONSTRUCTED DLD

As stated above, there are numerous sensor arrangements that could be used for generating the displacement signals, depending on what is readily available. For example, altitude rate can be used if doppler vertical velocity is not available (as is usually the case), or barometric altitude can be complementary filtered with vertical acceleration to form vertical displacement, although such a scheme is usually less responsive than is desirable.

The fact that the gradient signals are delayed by just over three seconds could result in slight miscompensation in very noisy areas where gradient changes rapidly. One solution would be to delay the DLD signal to match the gradient signals, but this might not be acceptable in a high performance detection algorithm. An alternative would be to "quicken" the gradient signals using differences between compensated DLD signals; the feasibility of such an algorithm has not yet been studied, but it will be should gradient signal delay prove to be a significant problem.

High Resolution MAD Data Channels

For future advanced MAD signal processing/detection experiments, the DLD signals can be fed in parallel to prewhitening filters having first-order highpass breakpoints of 0.176 Hz and gains variable in a 1-2-10-20-100 sequence. (These prewhitening filters are not shown in Figure 4). After digitization, the prewhitened signals are compensated in the same manner as is the conventional DLD except that the compensation signals are operated on by the same transfer functions as given by the prewhitening filters.

RESULTS TO DATE

MAD Complementary Filter

The filter has been designed, programmed and validated. It was tested by producing a sinusoidally varying magnetic field at one of the wingtip magnetometers and comparing the filter output (a blend of total field and DLD) with an exact electrical analog of the sinusoidal field. Frequency response was measured over 0.01 to 1.0 Hz. Amplitude error was less than 1.6%, and this occurred only around the very lowest frequency. Error in phase response was not measurable. Step response was somewhat sluggish and inclined to overshoot, but the filter is able to track accurately at the anticipated slewing rates for high speed flying in highest geology areas.

As a further check on the filter, the blended output, which is really a "high fidelity" total field signal, was high passed by a digital filter that matches the DLD highpass and this output was compared to the original DLD signal using typical flight data. Most plots showed tracking within a fraction of a gamma and we suspect some of the error to be due to slight differences between the digital and analog highpass mechanizations. The plot shown in Figure 6, although not one of the best examples, was selected because it can be seen that there really are two traces.

As shown in Figure 3, the crossover frequency selected for the complementary filter is 0.022 Hz, which seems about optimal for the two-second total field sampling period. Most of the testing was done using a DLD highpass that was also 0.022 Hz, but the filter was validated as well for a DLD highpass of 0.06 Hz and it appears that an even higher highpass frequency could be accommodated, if required, without loss of accuracy.

Magnetic Compensation

- a) **Wingtip Magnetometers** — Acceptable MAD passband compensation has been achieved for both magnetometers. For some reason yet to be analyzed, good solutions for each 18-term set of interference coefficients seem achievable without using the advanced regression methods that were often necessary with the North Star MAD system (Ref. 1). Table 1 shows compensation results for the two magnetometers along with some from the North star taken in the same low gradient area with approximately the same manoeuvres.

TABLE 1
COMPENSATION RESULTS (WINGTIP DLD'S)

	Port Mag	Stb. Mag	North Star
Uncomp FOM*	14.36 γ	10.47 γ	6.60 γ
Comp FOM	1.14 γ	0.97 γ	0.43 γ
Ratio	12.6 γ	10.47 γ	15.35 γ
σ_{UNCOMP} **	0.535 γ	0.375 γ	0.190 γ
σ_{COMP}	0.037 γ	0.030 γ	0.011 γ
Ratio	14.5	12.5	17.27

It can be seen from the uncompensated values that the Convair wingtip installations are approximately three times noisier than the North Star's magnetometer, which was at the end of a 16-foot tail boom.

Figure 7 shows a typical post-flight compensation on a set of FOM data. Figure 8 shows in-flight, on-line compensation (called "Software Compensation" in Fig. 4) for a portion of the same dataset. Figure 9 is also an on-line result for a moderately high gradient area; the higher manoeuvre-related residuals show the need for gradient compensation for single magnetometer operation, which has not yet been implemented in the Convair system.

- b) **Tail Magnetometer Compensation** — Compensation of this magnetometer presents a considerable challenge because it is not on a boom, but rather is embedded in the tail structure. There may be some near-field non-linear effects that are beyond the scope of the linear interference model. Furthermore, the tail magnetometer is strongly affected by stainless steel counterweights in the rudder, only the top third of which have been replaced by specially machined non-magnetic ones. Finally, rudder motions during manoeuvres are causing interference signals that do not correlate in any way with the interference model. All this adds up to a very noisy magnetometer, as shown by the uncompensated values in Table 2.

TABLE 2
COMPENSATION RESULTS (TAIL MAG. DLD)

Uncompensated FOM	144.6 γ	σ_{UNCOMP}	6.08 γ
Compensated FOM	20.85 γ	σ_{COMP}	1.40 γ
Ratio	6.94 γ	Ratio	4.33 γ

It can be seen that compensation is tending to be effective, but the improvement ratios typical of the wingtip magnetometers (approx. 13) have not yet been achieved.

* FOM = "Figure of Merit". Evaluated by doing standard amplitude pitches, rolls and yaws on the four cardinal headings with steep turns between headings.

** σ is the standard deviation of the DLD signal over the entire manoeuvre sequence. "Figure of Merit" applies only to the amplitudes of the standard manoeuvres.

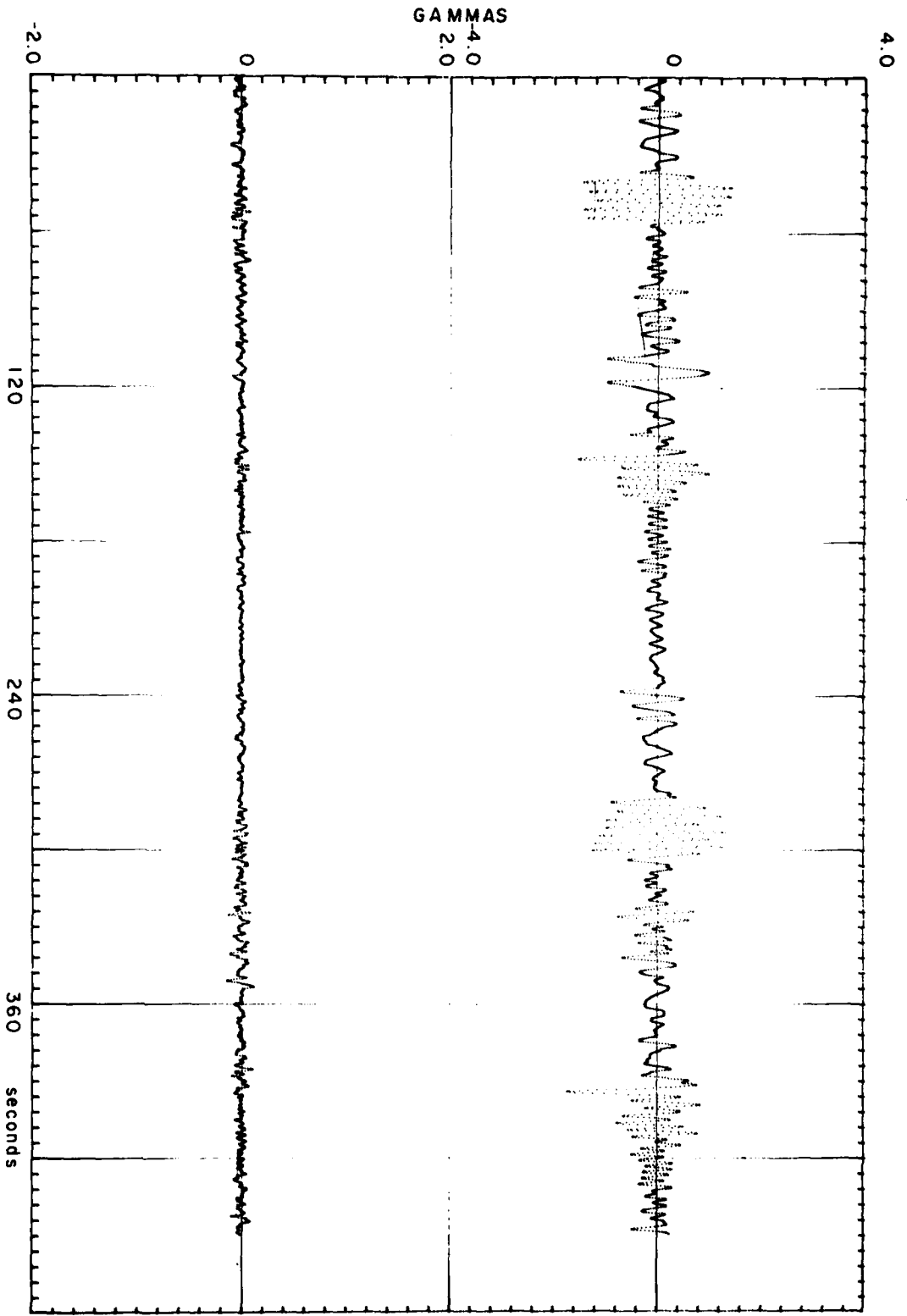

FIG. 7: POST-FLIGHT COMPENSATION (STB'D MAG)

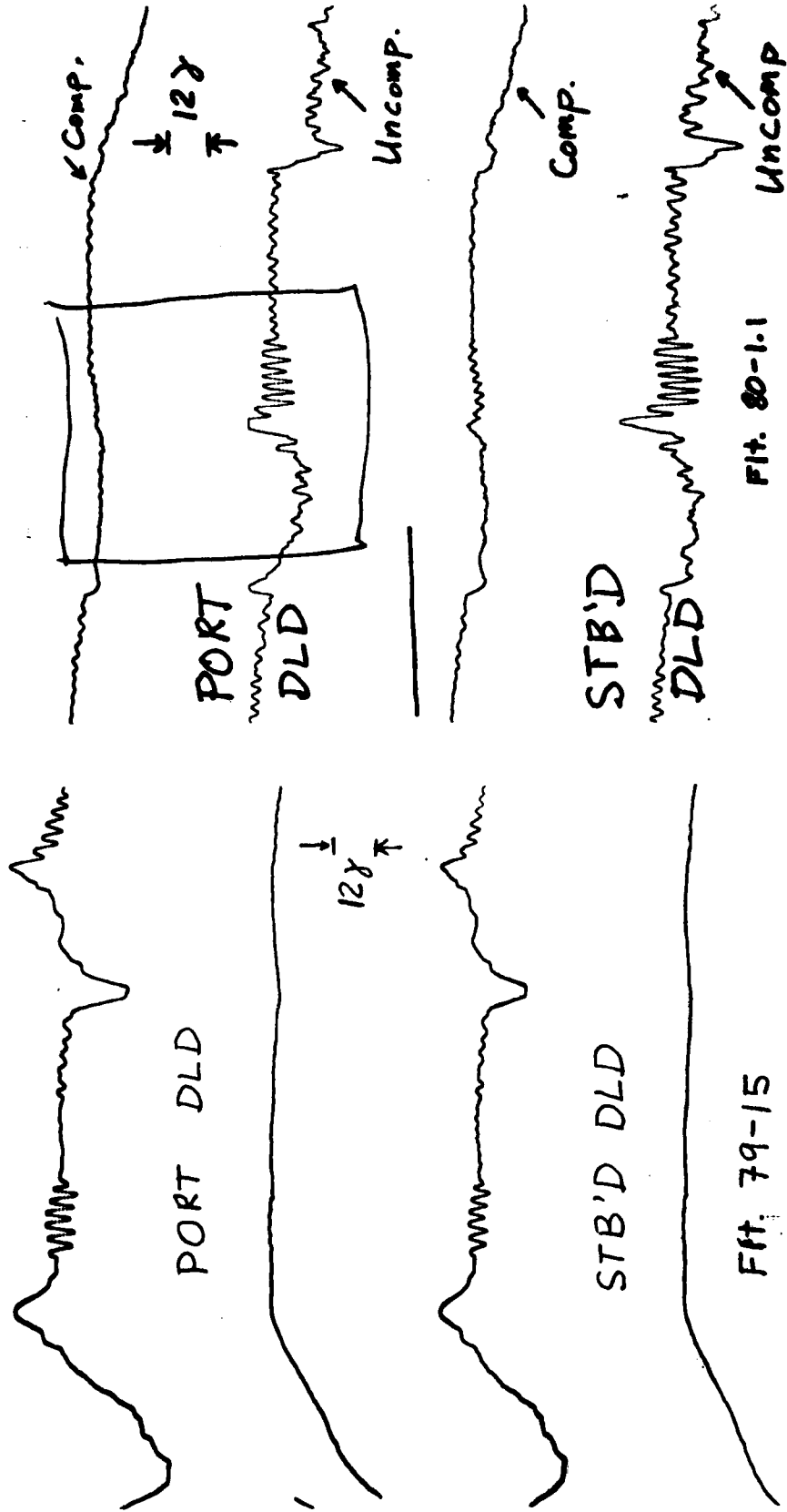

FIG. 9: IN-FLIGHT COMPENSATION
(HIGH GRADIENT AREA)

FIG. 8: IN-FLIGHT COMPENSATION

We expect to improve the compensation appreciably by eliminating the effects of rudder movement and then to achieve continued gradual improvement by a methodical magnetic cleanup of the rudder area. As stated at the beginning of this article, it is a research objective to see how close we can come to the compensation levels of the wingtip magnetometers using this simple tail magnetometer in a simple installation. It is just unfortunate that the place that gives maximum vertical separation for gradient work is far less than ideal in terms of magnetic environment.

- c) **Compensation of Vector Magnetometers** — The three-axis vector magnetometer is subject to the same type of magnetic interference as are the total field magnetometers. In addition, there can be alignment errors and non-orthogonality errors. (Scale factor and bias errors are treated as magnetic errors since they act in the same manner.)

Since errors in the vector magnetometers enter strongly into the "DC" compensation of the total field magnetometers, they must be minimized. A measure of how well the error model is working is given by comparing the fit between the root-sum-square (RSS) of the three components, with the measured total field from one of the other magnetometers during a FOM manoeuvre sequence; ideally, the two quantities should be equal. Another measure of performance is the fit of aircraft heading as derived from the vector magnetometers, to the heading as given by one of the aircraft's heading reference systems.

An RMS fit error of 33.4γ was obtained, which is close to the resolution of the digitization of the vector magnetometer signals, which in the worst case (for the transverse magnetometer) was 24.3γ , the data having been collected using the 12-bit converter.

TABLE 3
VECTOR MAGNETOMETER COMPENSATION

	Fit to Total Field		Fit to Heading Reference	
	Uncomp.	Comp.	Uncomp.	Comp.
Mean	233.6 γ	1.43 γ	0.96°	-0.22°
Std. Deviation	576.6 γ	33.4 γ	2.84°	1.50°

We expect an improved fit with the use of the 14-bit converter as shown in Figure 4. Further improvement is expected once some manoeuvre-related dynamic errors in the heading reference systems (which supply data to the error model) have been reduced.

- d) **"DC" Compensation** — Determination of the steady state offsets and the heading-dependent quasi-steady state errors in the magnetometers is of prime importance for measuring gradient. Experiments to date have delineated the problem but more flight data are needed before the required coefficients are available.

Passes over a carefully calibrated and monitored reference point (Bourget, Ontario) on cardinal headings gave the errors shown in Table 4. The reference total field is probably known to $\pm 1\gamma$ and small height variations, diurnal variations etc. were taken into account. It should be noted that these errors were for total field readings with no compensation applied.

TABLE 4

TOTAL FIELD ERRORS, 4 CARDINAL HEADINGS, NO COMPENSATION

	Port	Starb'd
Average Error	- 9.78 γ	8.23 γ
Max. Error (Heading)	-15.9 γ (South)	-12.1 γ (North)
RMS Error	4.33 γ	2.65 γ

The above errors do not fit the classical compass correction model for permanent and induced fields; such a model was constructed, but it would not hold up on intercardinal headings, illustrating its invalidity.

Applying the best DLD compensation coefficients to the Bourget data did not help; in fact, they made the errors larger. This led to the realization that *different sets of DLD compensation coefficients*, each of which gives good compensation within the MAD bandpass with almost unmeasurable differences between RMS residuals (σ_{COMP}), can cause significant and different shifts in the total field (DC and quasi-DC) values when applied.

Investigation of the effects of DLD compensation on total field readings was continued using *differences* between port and starboard magnetometers in a very low gradient area rather than using absolute total field references. The reason for this approach was that the gradients immediately surrounding Bourget are irregular and not particularly low, which causes manoeuvre data to be contaminated with gradient interference.

For a FOM manoeuvre dataset taken in a very low gradient area, blended, uncompensated total field traces for port and starboard magnetometers were plotted. It could be seen that they did not track each other and at one point, the two traces actually crossed. With application of compensation coefficients calculated using the standard FACS computation (Ref. 1), the two traces could be seen to track each other reasonably well, with an average difference of 40.78 γ and a standard deviation (σ) in this value of 1.27 γ . With application of compensation coefficients calculated using Ridge Regression (Ref. 1), the average difference between traces was 7.08 γ with a σ of 1.25, showing tracking to be about as good as for FACS coefficients. The results are summarized in Table 5. The average difference for the uncompensated case is shown in brackets because, with the traces not tracking each other and crossing, the average is not particularly meaningful; however, the high σ tells the story. Uncompensated difference figures for the two magnetometers are also shown for Bourget; although this is based on only four samples (vs over 3000 for the FOM), the same sort of difference is evident.

TABLE 5

PORT AND STARBOARD TOTAL FIELD DIFFERENCES

	Average Difference	Standard Deviation (σ)
Bourget, Uncompensated	1.55 γ	6.05 γ
FOM 79-15, Uncompensated	(0.23 γ)	4.29 γ
FOM 79-15, FACS Compensated	40.78 γ	1.27 γ
FOM 79-15, Ridge Compensated	7.08 γ	1.25 γ

In order to make meaningful gradient measurements between the wingtip magnetometers, which are separated by 100 feet, the difference between them due to aircraft interference must be reduced to about 0.1γ . The previous table shows that there is still a considerable reduction required. For vertical gradient, where magnetometer separation is only 17 feet, the challenge is even more severe.

The significant interim result is that total field readings can be greatly affected by different combinations of compensation coefficients. Another way of putting it is that coefficients that give satisfactory compensation in the MAD bandpass are unlikely to give correct compensation for total field measurements. The most widely used type of compensation is the very successful CAE nine-term analog system and airborne surveyors who are using it in combination with total field counters should be aware of potential inaccuracies.*

Considerable flight data are currently being analyzed in order to solve the problem of "DC" compensation and various computation techniques are being evaluated. The solution will be published as soon as it is available.

CONCLUSION

Much of the necessary groundwork has been carried out in order to achieve a flyable three-axis gradiometer and there is reasonable confidence that solution of the remaining problems is within the state-of-the-art. It is hoped that the foregoing discussions of techniques and problems will be of use to operators considering the use of gradiometry or to instrumentation developers who may already be conducting experiments in the field.

ACKNOWLEDGEMENTS

The author wishes to acknowledge the efforts of the NAE Convair Project Group in the areas of hardware and software design and data analysis. These efforts have contributed materially to the results obtained to date.

REFERENCES

- (1) Leach, B.W. *Automatic Aeromagnetic Compensation.*
NRC, NAE Laboratory Technical Report LTR-FR-69, National Research Council, March 1979.
- (2) Adkar, C.K.
Gibson, J.R. *First Report on Fully Automatic Compensation System.*
CAE TPD 6123, November 1968.
- (3) Hardwick, C.D. *Gradient Compensation.*
NRC, DME/NAE Quarterly Bulletin No. 1972(2), National Research Council, July 1972.

* This problem was noted on the North Star where a 16-term analog compensator was used. With the compensator turned on, it was not possible to correlate total field measurements with expected values.

URBAN TRAFFIC SIGNAL CONTROL FOR FUEL ECONOMY†

G.S. Messenger*, D.B. Richardson**,
P.W.U. Graefe*** and I.H. Mufti***

Engine and Analysis Laboratories

Division of Mechanical Engineering

SUMMARY

The Metropolitan Toronto Roads and Traffic Department and the Engine Laboratory of the Division of Mechanical Engineering at the National Research Council Canada have completed a study to determine the influence of two computer-controlled traffic signal timing plans over a given route. The two plans are the existing plan based on SIGRID (Signal GRID Design program) and TRANSYT (TRAffic Network StudY Tool).

The results show that under the TRANSYT timing plan, vehicles encountered fewer stops, saved time and used a slightly smaller amount of fuel than under the existing timing plan.

Vehicle fuel consumption was computed using a computer model of a vehicle which used velocity profiles obtained from an instrumented "floating" car. Single and multiple linear regression analyses were used to determine the relationship between the fuel consumption and the relatively easy-to-measure and statistically stable quantities such as trip time, number of stops and delay time.

It was found that fuel consumption could be expressed adequately as a linear combination of trip time, number of stops and delay time. Using only two independent variables showed a combination of delay time and stops to be equally as good as a combination of travel time and stops. When restricted to a single independent variable, any one of them could be used for predicting fuel consumption.

1.0 INTRODUCTION

1.1 General

The Roads and Traffic Department of the Municipality of Metropolitan Toronto has been a world leader through the introduction and development of computerized control of traffic signals. There is an increasing public awareness of the environmental impact of the automobile in relation to noise and emission levels, and there exists a strong desire to achieve greater economy in fuel consumption in light of rising energy costs. In consequence, the provision of an efficient traffic signal control system has become extremely important in urban areas. Through the development of more sophisticated control techniques, significant progress has been made in improving the operation of urban traffic signal systems. Computer control of these signals has given the traffic engineer the opportunity to effectively co-ordinate traffic movements over a large area with a resulting decrease in unnecessary stops and delays. This results in corresponding improvements in vehicular travel times and overall safety of operation.

† Based on paper by same title, MF-247, in printing.

* Engine Laboratory.

** Metropolitan Toronto Traffic Control Centre.

*** Analysis Laboratory.

A joint research venture was undertaken with the Engine Laboratory of the National Research Council whereby the actual effect of urban traffic signal timings on vehicular fuel consumption could be investigated.

Over 50% of the petroleum products consumed in North America every year are used for the purpose of transportation. Since over 80% of this fuel is consumed by road users, it is apparent that any improvements in the efficiency of its use can result in substantial economic and environmental benefits. It has not been conclusively proven however, that a traffic signal control strategy based on minimizing vehicular travel times is the most economic in terms of fuel usage. In fact, some recent studies in Europe have indicated that significant fuel savings may be possible by employing a different signal control philosophy. Research done in Glasgow (Ref. 1) found that minimizing the number of stops resulted in a decrease in fuel consumption of 5.8% while average journey time increased 0.3%. Conversely, studies by General Motors Corporation in the U.S. (Refs. 2 to 9) showed that the fuel consumption per unit distance could be reduced by decreasing the average trip time. It was found that fuel consumption per unit distance could best be accounted for in terms of average trip time per unit distance. If K_1 and K_2 are calibration constants, where K_1 is the fuel used to overcome rolling resistance, and K_2 is the idle fuel flowrate, it was demonstrated that the following linear equation is a simple but effective method of predicting fuel consumption:

$$\phi = K_1 + K_2 t \quad (1)$$

where

ϕ = fuel consumption per unit distance

t = trip time per unit distance

For urban trips slower than 60 km/h it was found that the single parameter of average trip time per unit distance explained more of the variance in fuel consumed per unit distance than any other parameter considered. Equation (1) shows that for a certain fixed trip length, fuel consumption could be reduced by decreasing the average trip time. This equation was developed from actual fuel flow measurements, and the average values given for K_1 and K_2 were 0.0852 L/km and 2.824 L/h, respectively, for one series of tests (Ref. 9).

The Toronto study described below presents data showing the influence of two computer controlled signal timing schemes on fuel consumption. Figure 1 is a map of the 2.79 km (1.73 mile) test route on Lawrence Avenue East in a light industrial/commercial area of Metropolitan Toronto. This route was selected since it had recently been widened to a 7-lane cross-section with a continuous two-way left-turn median lane. All intersections are suburban high-type with exclusive turn lanes, good visibility, pavement structure, markings and turning radii. Therefore, the test section is essentially free-flow during both the offpeak and rush hour periods of the day. Traffic congestion is minimal along the entire stretch and there is a low frequency of stops other than those caused by the traffic signals. Thus, any delays which occur along this section of roadway are almost entirely signal-related, and show any differences between the two timing schemes. Vehicular volumes are very directional during the two peak periods and almost equally balanced during the offpeak hours of the day. This offers a wide range of prevailing traffic conditions, from heavy well-platooned flows during the high volume peak periods, to light unstructured flows during the mid-day hours. Cycle lengths are identical throughout the network to permit co-ordination among all signals, but the actual timings vary from intersection to intersection depending on the side-street volume/capacity ratios.

It is anticipated that the results derived from this test network will be applicable to any traffic signal controlled situation in an urban environment. Since the emphasis was placed on delay, stops and travel time with respect to the signals alone, the results do not reflect the impact of uncontrollable parameters such as midblock parking and stopping activities, excessive queueing, pedestrian crosswalks, and heavy turning movements.

1.2 Traffic Signal Timing Plans

The underlying assumption used in the application of the two plans was that the prevailing signal splits and cycle lengths were at or near the optimum for the seven signalized intersections.

The splits at the critical signals were designed with reference to the volume/capacity ratios on all the approaches. The cycle lengths were determined by considering the volume/capacity relationship in conjunction with constraints set by pedestrian requirements, clearance interval design, and queue storage problems. In the case of minor intersections in the remainder of the network, the cycle is governed by the critical signals, and the splits are governed by cross street pedestrian walk times.

Since the cycles and splits were fixed for both control strategies, the only remaining variable to be optimized was the "offset" or start of the main street green interval at each signal, relative to a master clock.

1.2.1 The Existing Plan

The existing signal timings for the Metropolitan Toronto signal system are basically the result of applying the "SIGRID" off-line optimization program. The SIGRID (Signal GRId Design) program (Ref. 10) was originally developed by the Traffic Research Corporation for the Metropolitan Toronto Roads and Traffic Department as a computational tool for signal network offset design. Given the system cycle length, signal splits, and "ideal" or "desirable" offset differences for the various individual links in a signal network, the program systematically searches for the set of offset values which are closest to their corresponding ideal values and yet satisfy the network constraints.

The existing plan for the test network was derived initially from the SIGRID program together with continuous "manual tuning" and upgrading efforts over the years. Since Lawrence Avenue East is a carrier of significantly higher volumes of traffic than most of the roads which it intersects, a "preferential street treatment" can be applied. This technique essentially involves favouring the directions of travel with heavier traffic volumes during the peak periods. A "balanced" arrangement is provided during the mid-day offpeak hours when no particular directionality is evident in the east-west movements.

1.2.2 The TRANSYT Program

TRANSYT (TRAffic Network StudY Tool) was developed by D.I. Robertson (Ref. 11) as a co-operative effort between the British Road Research Laboratory and Plessey Automation.

To find the optimum signal settings for the network, a system performance index expressed in terms of system delay and stops is used in the program as an engineering evaluation tool. To calculate this performance index, a traffic flow model is used to compute the required pattern information on each link. In the flow computation routine, the cycle is divided into a number of equal units of time, and the flow rate entering a link during each interval is assumed to be a given fraction of the flow leaving the upstream links. To obtain the arrival rates at the downstream signal, the flow entering the link is exponentially smoothed by the use of Robertson's platoon dispersion model (Ref. 12). The departure rate leaving the link is assumed to be equal to the saturation flow when a queue exists at the signal approach, or equal to the arrival rate if no queue is present.

In the optimization logic of TRANSYT, a hill-climbing iteration process is used to obtain a set of optimum signal settings which will minimize the performance index.

For this study TRANSYT/5 was used since it had been previously tested in Metropolitan Toronto during the IOUTS study (Ref. 13) and was fully operational on the Univac 1107/418 system at the Traffic Control Centre.

2.0 INSTRUMENTATION

Data were obtained by an instrumented vehicle defined as a "floating" car, which recorded on magnetic tape the vehicular velocity as measured by a Nucleus Corporation fifth wheel using both analog and digital signals. The digital signal consisted of 70 pulses per wheel revolution. One channel of the Bruel and Kjaer, Type 7003, recorder was used for voice identification of the runs and another was used for a "blip" signal which was used as a high speed read signal for the computer.

3.0 TEST PROCEDURE

The fifth wheel was attached to its bracket as shown in Figure 2 and its output checked at the beginning of a test series. The tape recorder was turned on at the start of a test series and allowed to run continuously. Each speed and delay "run" was identified by voice with time of day, date, run number and direction. The "blip" switch was turned on at the beginning of the run and shut off at the end of the run. Approximately 3-5 minutes of tape were left blank between runs to act as a separator. Each signalized intersection was identified by voice to aid in analysis. Several times during each run the recorded signals were monitored to ensure that all systems were functioning properly.

During the test runs the car driver operated the blip switch and the microphone at the same time. It was found on analysis that the blip signal was forgotten or late at the beginning and end of some runs. Approximately 20% of the runs were rejected because of this problem. Some difficulty was experienced with loosening of the bracket attaching the fifth wheel to the car. Other than a bulb failure in the fifth wheel pulse sending unit, the test equipment performed as expected. Calibration of the fifth wheel was done on a Nucleus Corporation calibrator before the test series.

3.1 Manual Collection of Speed and Delay Data

Simultaneous to the instrumented car tests, speed and delay data were collected by the observer during each pass through the network. As in a normal floating car survey, the drivers were instructed to "float" among the vehicular platoons, in essence behaving like an average motorist. As a link boundary was crossed, the observer noted the cumulative link journey time and the link stopped time from the appropriate stopwatches. In this study, the far-side curb lines were considered the link boundaries or reference points.

In addition, he/she also noted the reason for the stopped time and any general comments regarding anomaly events. A "signal stop" was only recorded if the traffic was freely flowing to the signal and the delay was caused entirely by the signal itself. A delay was noted if the vehicle speed was less than 8 km/h (5 mph) while approaching a signal, subject to the judgement of the survey crew. Where signal stops were greater than one signal cycle in duration, an additional stop was recorded for each signal cycle delayed.

Table 1 indicates the signal control periods or "optimization time periods" during which the peak and offpeak runs were completed. The number of data samples gathered during the tests are presented in Table 2. It should be noted that all offpeak runs were carried out during the morning mid-day period. Only one of the two offpeak periods had to be investigated since an adequate sample size was obtained, and because of past volume trends the morning period was considered representative of "balanced" conditions.

4.0 REDUCTION OF FIELD DATA

To decode the recorded signals, the digital velocity signal and the analog "blip" signal were coupled to the Compact System Controller (CSC) which is part of the PDP 11/34 computer data acquisition sub-system. The computer's frequency counter tallied the number of pulses per second and the computer converted these to km/h at one second intervals by dividing by the wheel's calibration factor of 9.20945. Any speed less than 2 km/h was set to 0 km/h to avoid the problem of trying to count 0 pulses at a stopped condition. These data were stored, linearized, and then plotted. Figure 3 is a schematic of the data flow.

Each "speed and delay" run was processed individually. Typical linearized velocity profiles with points at one second intervals are shown on Figures 4 to 7. The velocity profile data were then entered into the NRC Computation Centre IBM 370 computer system for use in the Vehicle Simulator Program. These velocity profiles will be useful in future studies of acceleration and deceleration rates and in actual traffic simulation studies. They will also give the traffic engineers involved an accurate pictorial representation of actual conditions on the street.

5.0 FUEL CONSUMPTION CALCULATIONS

The "floating" car determined the typical driving pattern or velocity profile which is virtually independent of the vehicle type. The Vehicle Simulator (VS) program (Ref. 14) calculates fuel consumption using this velocity profile and the characteristics of a specific vehicle. All calculations were done using the original VS vehicle, a 2177 kg (4800 lb) car with automatic transmission and a 6554 cc (400 in³) spark ignition engine. It was assumed for the spark ignition case that trends shown in fuel consumption will be reasonably similar regardless of the engine size used in the simulation.

A vehicle model was used to calculate fuel consumption from actual velocity profiles rather than measuring fuel flow in a real vehicle. This was done to reduce the number of on-street runs required by eliminating the effects of individual drivers, state of tune and type of vehicle, tire inflation and environmental factors. Also, different engine-drive train characteristics could be used in the program without having to re-measure the actual flow of fuel. The above factors must be accounted for in order to make accurate fuel consumption measurements, but they are unrelated to the effect of various traffic signal timings on the actual vehicular velocity profiles.

Simpler models for fuel consumption were obtained using the fuel consumptions calculated above and relating them to observed trip times, stops and delay times. These quantities are easier to measure than the velocity profiles. Single and multiple regression analyses provided the necessary coefficients to express fuel consumption as linear functions of trip time, stops and delay or any subset of these three.

6.0 ANALYSIS

Mean values of time, fuel consumption, stops and delay (all per unit distance) for the three different periods of day and traffic direction were computed for each of the two signal light timing plans. For the fuel consumption, student "t" tests showed that in almost all cases there was a statistically significant difference between corresponding results obtained under the existing and TRANSYT timing plans.

Regression results were derived from the International Mathematical and Statistical Libraries, Inc. (IMSL) subroutines "RLONE" for single regressions and "BECOVN" in combination with "RLMUL" for multiple regressions. These subroutines are an accepted standard for statistical analysis and each of them is available on the NRC TSS 370 computer.

In conjunction with this analysis, the Traffic Control Centre staff carried out a detailed summarization of the manually-collected speed and delay information. This was done by means of the "SPEEDA" program which calculates link averages for speeds, travel times, stops, and delays, and then summarizes the data over the whole route by direction of travel and time of day. The program also calculates a performance index, which gives a relative measure of effectiveness, and enables comparisons to be drawn between the two signal timing plans. In addition, single linear regression analysis was done using the "REGR" program which is available on the Traffic Control Centre's Univac 1107/418 computer system. The results compared favourably with those obtained from the IMSL programs which lends credence to both the manual and automatic data collection techniques as well as the resulting computer analysis.

7.0 RESULTS

The mean values of travel time, calculated fuel consumption, stops and delay, expressed in units of sec/km, ml/km, stops/km and sec/km respectively, are shown in Table 3 in order to compare the existing and TRANSYT plans. The significance levels determined from the student "t" distribution are also included in Table 3 for travel time and fuel consumption. Figure 8 is a histogram of the data from Table 3. Interpretation of significance levels gives an indication of whether the means are from the same parent population or from different ones. For example, a significance level

of .01 indicates that there is only a 1% chance that the two means considered are from the same population, or alternatively, there is a significant difference between the sample means. On the other extreme, a significance level of .8 indicates that there is an 80% chance that the means are from the same population, or there is an 80% chance that the means are from the same population, or in fact there is no significant difference between the two means.

The favoured flow or high volume directions are westbound in the morning rush hour and eastbound in the evening. It can be seen that TRANSYT generally has a larger beneficial effect in a direction opposite to that of the majority of roadway users. For example, during the evening rush hour, the "floating" car travelling westbound was 31.6% faster under the control of the TRANSYT plan. By comparison, the eastbound flow during the evening rush hour performed better under the existing timings by a margin of 7.6% in terms of overall travel time. These results should not be interpreted as an indication that TRANSYT favours only the lighter direction of travel. The reasons for the greater benefits being realized by the non-favoured flow direction were due to the preferential street treatment under the existing plan. When the signal offsets favour only the heavy direction, then the opposing movements frequently experience a significantly higher number of stops and delays. The TRANSYT plan attempts to achieve more of an equitable arrangement, whereby the heavy direction is still favoured on the strength of its high volume, but not at the total expense of the lighter flow. In fact, during the A.M. and offpeak periods, TRANSYT was able to improve on the existing timings even for the heavy direction of travel.

In general, the beneficial effects of TRANSYT in the non-favoured flow direction were so pronounced, that despite the lower traffic density in this direction, the overall, weighted effect of TRANSYT on travel times, fuel consumption, number of stops, and delay always resulted in an improvement compared to the existing schedule. The cumulative beneficial effects of TRANSYT over the existing plan are reductions of 12.4% in time, 2.2% in fuel, 40.4% in delay and 34.5% fewer stops. Table 4 summarizes traffic volumes and weighted means.

From Table 5 we see that between 73% to 95% of the variation in fuel consumption is explained when all three independent variables delay, stops and time are used together. When this case is compared with either of the best two-variable cases — delay and stops or time and stops, it can be seen that little is added to the total variation explained by the inclusion of a third variable. Both of the above two-variable cases are equally good in their percentages of variation explained. There is an advantage from a practical point of view in selecting the time and stops results since travel time is easier to measure than delay time.

In the single variable case, a good percentage of variations (55% to 90%) in fuel consumption can be accounted for by any one of the three variables — time, stops and delay. Delay alone explained the highest variation in three cases, stops in two cases and time in one case. This is somewhat different from the findings of General Motors (Refs. 2-9) where time alone explained more than 70% of the variation in the fuel consumption.

Tables 6 and 7 are multiple regression listings of intercept, coefficients and percent of variation explained for delay and stops combined and stops and time combined. The prediction equation of the fitted plane is of the form:

$$y = b_0 + b_1 x_1 + b_2 x_2 \quad (2)$$

where

y = fuel consumption, ml/km

b₁ = regression co-efficient of x₁, ml/stop

x₁ = stops/km

b₂ = regression co-efficient of x₂, ml/sec

x₂ = delay time or travel time, sec/km

Tables 8 to 11 are regression listings of slope, Y intercept and percent of variation explained for fuel versus delay, fuel versus stops, fuel versus time and time versus stops respectively. The slope figures can be used to give:

- 1) the cost of a stop in terms of time or fuel, and
- 2) the rate of fuel usage.

The prediction equation of the regression line for the data in Tables 8 to 11 is of the form:

$$y = mx + b \quad (3)$$

where A) for Tables 8 and 10, combined directions

y = fuel consumption, ml/km

m = slope, ml/sec

b = y axis intercept, ml/km

x = delay time or travel time, sec/km

B) for Table 9, combined directions

y = fuel consumption, ml/km

m = slope, ml/stop

b = y axis intercept, ml/km

x = stops/km

C) for Table 11 separate directions

y = time, sec/km

m = slope, sec/stop

b = y axis intercept, sec/km

x = stops/km

8.0 CONCLUSIONS

(1) Improvements with TRANSYT in travel time, fuel and stops were found in both directions for the three time periods with the exceptions of the eastbound evening rush hour and fuel consumption in the westbound morning and offpeak periods. TRANSYT decreased delay in all but the westbound morning rush hour.

(2) Overall, the TRANSYT plan reduced travel time by 12.4%, delay by 40.4%, had 34.5% fewer stops and saved 2.2% in fuel when compared to the existing schedule.

(3) Between 73% and 93% of the variance in fuel consumption could be explained by multiple linear regression analysis using time, stops and delay as independent variables.

(4) Use of only two independent variables in such an analysis causes very little information to be lost. Between 71% and 93% of the variance in fuel consumption could be explained by considering either a combination of delay time and stops or travel time and stops.

(5) When using a single independent variable in the regression analysis to estimate fuel consumption, any one of delay, stops or time may be used. However, only between 55% and 90% of the variance in fuel consumption can be explained in this way.

9.0 ACKNOWLEDGEMENTS

The authors wish to thank Mr. Joseph K. Lam, Senior Traffic Engineer, and the staff of the Metropolitan Toronto Traffic Control Centre for the collection and partial analysis of the floating car data. In addition, they would like to acknowledge the assistance of Mr. Don M. Rudnitski of the Engine Laboratory at N.R.C. This work was partially supported by grants from the Transportation Research and Development Centre of Transport Canada.

10.0 REFERENCES

1. Easingwood-Wilson, D. *An Instrumented Car to Analyse Energy Consumption on the Road.*
Nowotny, P.M. TRRL Laboratory Report 787, 1977.
Pearce, T.C.
2. Evans, L. *Multivariate Analysis of Traffic Factors Related to Fuel Consumption in Urban Driving.*
Herman, R. Transportation Science, Vol. 10, No. 2, May 1976, pp. 205-215.
Lam, T.
3. Chang, M.F. *Gasoline Consumption in Urban Traffic.*
Evans, L. Transportation Research Record 599 (1976), pp. 25-30.
Herman, R.
Wasielewski, P.
4. Evans, L. *A Simplified Approach to Calculations of Fuel Consumption in Urban Traffic Systems.*
Herman, R. Traffic Engineering & Control, Aug./Sept. 1976, pp. 352-354.
5. Evans, L. *Gasoline Consumption in Urban Traffic.*
Herman, R. SAE 760048, 1976.
Lam, T.
6. Evans, L. *Automobile Fuel Economy on Fixed Urban Driving Schedules.*
Herman, R. Transportation Science, Vol. 12, No. 2, May 1978, pp. 137-152.
7. Evans, L. *Urban Traffic, Fuel Economy and Emissions - Consistency of Various Measurements.*
SAE 780934, 1978.
8. Evans, L. *Urban Fuel Economy: An Alternative Interpretation of Recent Computer Simulation Calculations.*
Herman, R. Transportation Research, Vol. 12, pp. 163-165.
9. Chang, M.F. *Estimates of Fuel Savings Through Improved Traffic Flow in Seven U.S. Cities.*
Horowitz, A.J. General Motors Research Publication #2801, August 1978.

10. Traffic Research Corporation
SIGRID Program: Notes and User's Manual.
Toronto Traffic Control Centre, 1965-73 (unpublished).
- 11a). Robertson, D.I.
TRANSYT: A Traffic Network Study Tool.
Road Research Laboratory, Report No. LR253, 1969.
- b). Robertson, D.I.
User Guide to TRANSYT, Version 5.
Road Research Laboratory, Technical Note TN813, March 1973 (unpublished).
12. Robertson, D.I.
Dispersion of Platoons Leaving a Traffic Signal.
Research Leaflet LF112, Road Research Laboratory, 1967.
13. Rach et al.
Improved Operation of Urban Transportation Systems — Volume 2: The Evaluation of Off-Line Area Traffic Control Strategies.
Metropolitan Toronto Roads and Traffic Department, November 1975.
- 14a). Beachley, N.H. et al.
Increased Fuel Economy in Transportation Systems by Use of Energy Management Vol. 1 — General Results and Discussion.
PB-240 220, Wisconsin University.
- b). Beachley, N.H.
Frank, A.A.
Increased Fuel Economy in Transportation Systems by Use of Energy Management — Vol. II — Digital Automotive Propulsion Simulator Programs and Description.
DOT-TST-75-2.
- c). Beachley, N.H.
Frank, A.A.
Increased Fuel Economy in Transportation Systems by Use of Energy Management, Second Year Program.
Final Report, DOT-TST-76-57, December 1975.
- d). Beachley, N.H.
Frank, A.A.
Increased Fuel Economy in Transportation Systems by Use of Energy Management, Third Year Program.
Final Report, DOT-TST-77-21, 1976.

TABLE 1

SIGNAL CONTROL PERIODS (OPTIMIZATION TIME PERIODS - O.T.P.)

O.T.P.	Time of Day	Reference Name
1	7:00 a.m. - 9:00 a.m.	Morning
2	10:00 a.m. - 12:00 noon	Offpeak
3	1:00 p.m. - 3:00 p.m.	Offpeak
4	4:00 p.m. - 6:00 p.m.	Evening

TABLE 2

FLOATING CAR SURVEY SAMPLES

Control Plan	O.T.P.	Eastbound	Westbound
Existing	1	19	17
	2	20	20
	3	0	0
	4	19	19
	Total		<u>58</u>
TRANSYT	1	18	18
	2	24	22
	3	0	0
	4	18	20
	Total		<u>60</u>

TABLE 3
MEAN VALUES OF TIME, FUEL, STOPS AND DELAY

	Direction	Control Plan	Number of Data Points	Time sec/km	"t" Test Significance Level	Fuel ml/km	"t" Test Significance Level	Stops stops/km	Delay sec/km
Morning	E	E	18	120.3	<0.01	245.0	<0.01	1.58	36.9
		T	16	90.3		216.6		0.81	12.2
	W	E	13	90.3	0.8	204.0	0.56	0.55	14.4
		T	17	88.5		209.6		0.53	15.2
Offpeak	E	E	17	94.6	<0.01	210.6	<0.01	0.80	17.9
		T	17	74.0		196.2		0.34	4.9
	W	E	17	81.8	0.02	197.3	0.90	0.49	10.5
		T	16	73.9		198.3		0.36	8.0
Evening	E	E	13	94.2	0.4	196.4	0.04	0.50	21.8
		T	11	101.4		217.2		0.62	20.4
	W	E	18	118.8	<0.01	244.1	<0.01	1.54	38.4
		T	11	81.3		210.2		0.59	12.3

TABLE 4
TRAFFIC VOLUME AND WEIGHTED MEANS

Time and Vehicles/Hr	Control Plan	Weighted Over Day				Control Plan	Weighted Over Day			
		Time sec/km	Fuel ml/km	Stops stops/km	Delay sec/km		Time sec/km	Fuel ml/km	Stops stops/km	Delay sec/km
Morning East 669 West 1503	E	99.5	216.6	0.87	21.3	E	98.7	213.6	0.84	22.5
	T	89.1	211.8	0.62	14.3					
Offpeak East 728 West 950	E	87.4	203.1	0.62	13.7	T	86.5	209.0	0.55	13.4
	T	73.9	197.4	0.35	6.7					
Evening East 1452 West 1175	E	105.2	217.7	0.96	29.2	T	86.5	209.0	0.55	13.4
	T	92.4	214.1	0.61	16.8					

TABLE 5

REGRESSION RESULTS

		MORNING		OFFPEAK		EVENING	
Number of Data Points	%	EXISTING	TRANSYT	EXISTING	TRANSYT	EXISTING	TRANSYT
				31	33	34	33
	Explained by						
	Time, Stops and Delay All 3 Together	85.7	72.5	75.2	76.5	92.7	91.5
	Time and Stops Both Together	84.2	72.5	71.2	71.0	92.7	89.0
	Time and Delay Both Together	85.5	63.5	69.7	72.3	87.0	89.9
	Stops and Delay Both Together	84.5	68.2	75.1	76.2	90.8	91.5
	Time — sec/km Only	83.9	62.6	62.9	55.5	86.9	76.6
	Stops — stops/km Only	77.5	64.4	68.0	68.9	88.2	77.6
	Delay — sec/km Only	82.1	54.8	69.2	72.1	74.1	89.8

TABLE 6
 INTERCEPT, COEFFICIENTS AND % OF VARIATION EXPLAINED FOR DELAY AND STOPS (BOTH TOGETHER)
 VERSUS FUEL REGRESSION BOTH DIRECTIONS TOGETHER

	EXISTING					TRANSYT				
	Y Intercept ml/km	X ₁ Coeff. ml/stop	X ₂ Coeff. ml/sec	% Variation Explained	Y Intercept ml/km	X ₁ Coeff. ml/stop	X ₂ Coeff. ml/sec	% Variation Explained		
MORNING	182.6	15.7	1.0	84.5	188.3	26.8	0.5	68.2		
OFFPEAK	173.4	22.3	1.1	75.1	182.0	19.9	1.3	76.2		
EVENING	168.8	34.8	0.5	90.8	189.0	13.2	1.0	91.5		

TABLE 7
INTERCEPT, COEFFICIENTS AND % OF VARIATION EXPLAINED FOR STOPS AND TIME (BOTH TOGETHER)
VERSUS FUEL REGRESSION: BOTH DIRECTIONS TOGETHER

	EXISTING				TRANSYT			
	Y Intercept ml/km	X ₁ Coeff. ml/stop	X ₂ Coeff. ml/sec	% Variation Explained	Y Intercept ml/km	X ₁ Coeff. ml/stop	X ₂ Coeff. ml/sec	% Variation Explained
MORNING	101.9	7.2	1.1	84.2	136.9	22.5	0.7	72.5
OFFPEAK	137.4	28.0	0.6	71.2	152.3	33.1	0.5	71.0
EVENING	118.4	25.9	0.7	92.7	151.3	26.9	0.5	89.0

TABLE 8

SLOPE, INTERCEPT AND % OF VARIATION EXPLAINED FOR FUEL
VERSUS DELAY REGRESSION BOTH DIRECTIONS TOGETHER

	EXISTING			TRANSYT		
	Slope ml/sec	Y Intercept ml/km	% Variation Explained	Slope ml/sec	Y Intercept ml/km	% Variation Explained
MORNING	1.5	186.1	82.1	1.2	196.1	54.8
OFFPEAK	2.0	175.6	69.2	2.1	183.6	72.1
EVENING	1.6	172.3	74.1	1.3	191.9	89.8

TABLE 9

SLOPE, INTERCEPT AND % OF VARIATION EXPLAINED FOR FUEL
VERSUS STOPS REGRESSION BOTH DIRECTIONS TOGETHER

	EXISTING			TRANSYT		
	Slope ml/sec	Y Intercept ml/km	% Variation Explained	Slope ml/sec	Y Intercept ml/km	% Variation Explained
MORNING	39.4	182.6	77.5	37.8	187.9	64.4
OFFPEAK	42.6	176.6	68.0	42.7	182.4	68.9
EVENING	46.1	173.4	88.2	45.8	186.0	77.6

TABLE 10

SLOPE, INTERCEPT AND % OF VARIATION EXPLAINED FOR FUEL
VERSUS TIME REGRESSION BOTH DIRECTIONS TOGETHER

	EXISTING			TRANSYT		
	Slope ml/sec	Y Intercept ml/km	% Variation Explained	Slope ml/sec	Y Intercept ml/km	% Variation Explained
MORNING	1.3	86.8	83.9	1.3	100.9	62.6
OFFPEAK	1.3	88.4	62.9	1.4	92.7	55.5
EVENING	1.4	68.9	86.9	0.9	132.2	76.6

TABLE 11

SLOPE, INTERCEPT AND % OF VARIATION EXPLAINED FOR TIME
VERSUS STOPS REGRESSION EAST AND WEST DIRECTIONS

	Direction	EXISTING			TRANSYT		
		Slope sec/stop	Y Intercept sec/km	% Variation Explained	Slope sec/stop	Y Intercept sec/km	% Variation Explained
MORNING	East	38.2	60.1	62.4	14.8	78.3	34.8
	West	27.6	75.1	92.3	31.7	71.7	79.5
OFFPEAK	East	24.9	74.7	76.2	21.4	66.8	55.8
	West	18.3	73.0	51.2	21.4	66.2	67.2
EVENING	East	45.4	71.7	93.1	46.9	72.3	82.6
	West	32.8	68.4	44.8	16.4	71.7	55.1

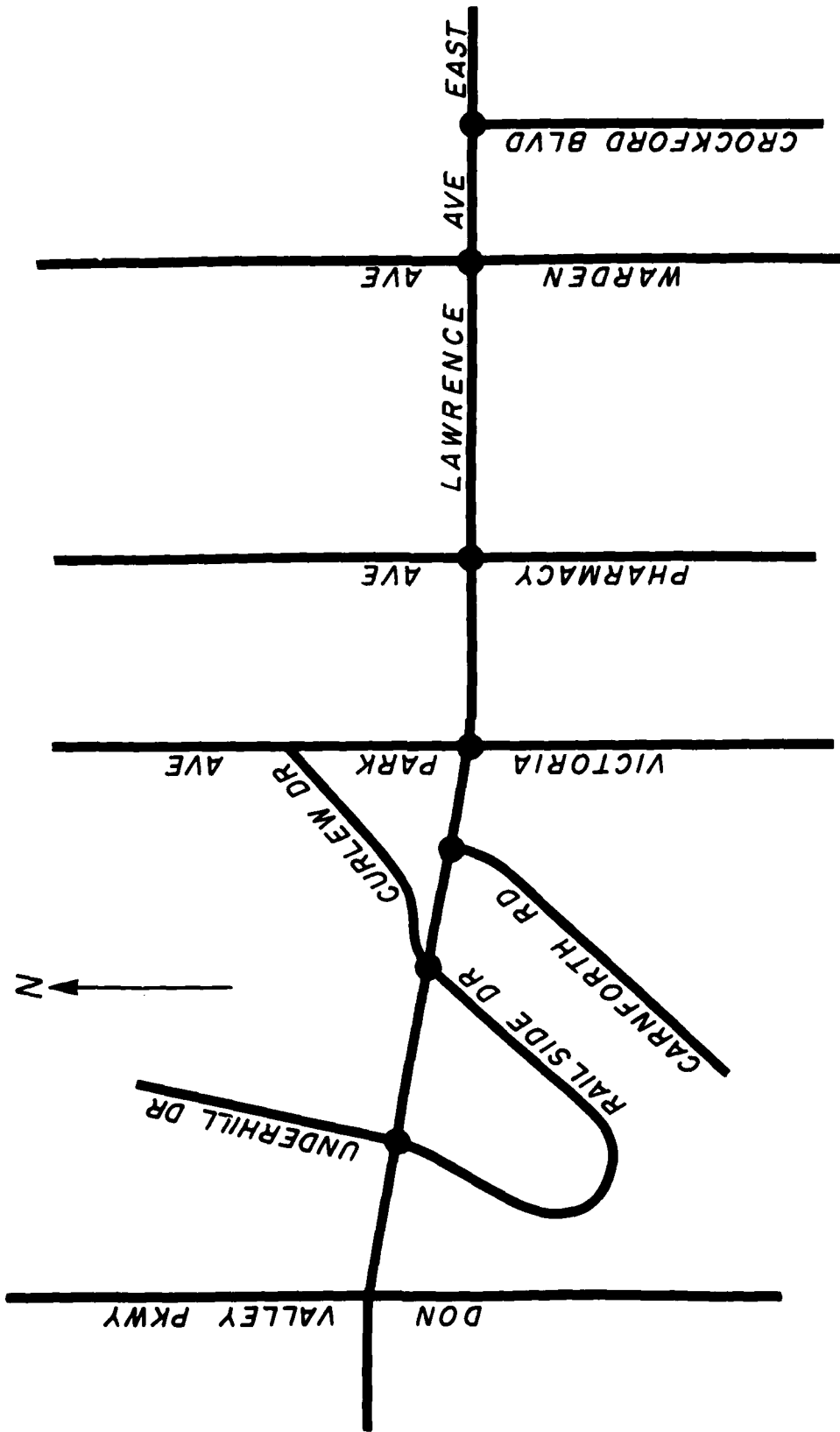

FIG. 1: TEST ROUTE - LAWRENCE AVE. EAST



FIG. 2: FIFTH WHEEL ATTACHED TO "FLOATING CAR"

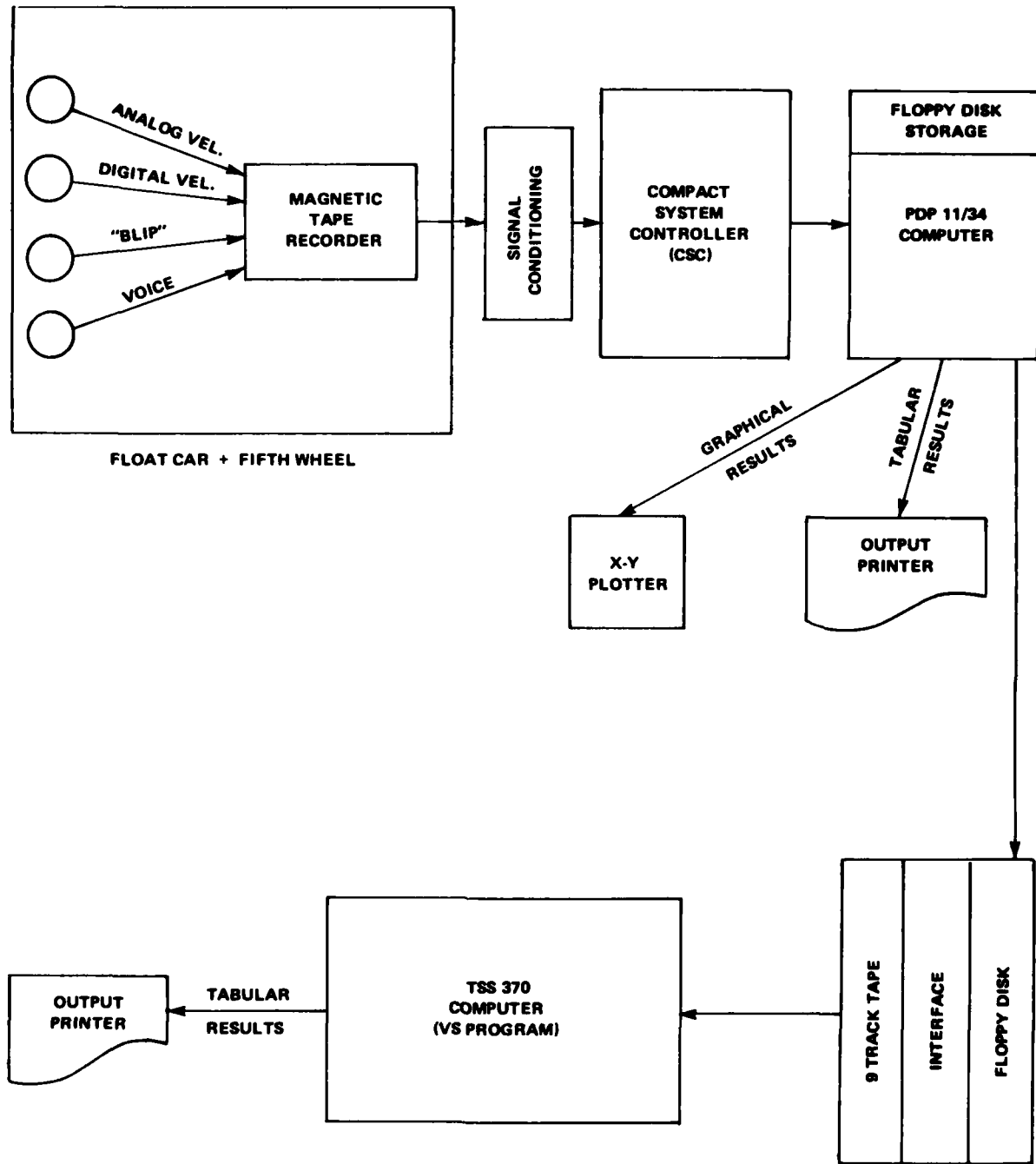

FIG. 3: DATA FLOW SCHEMATIC

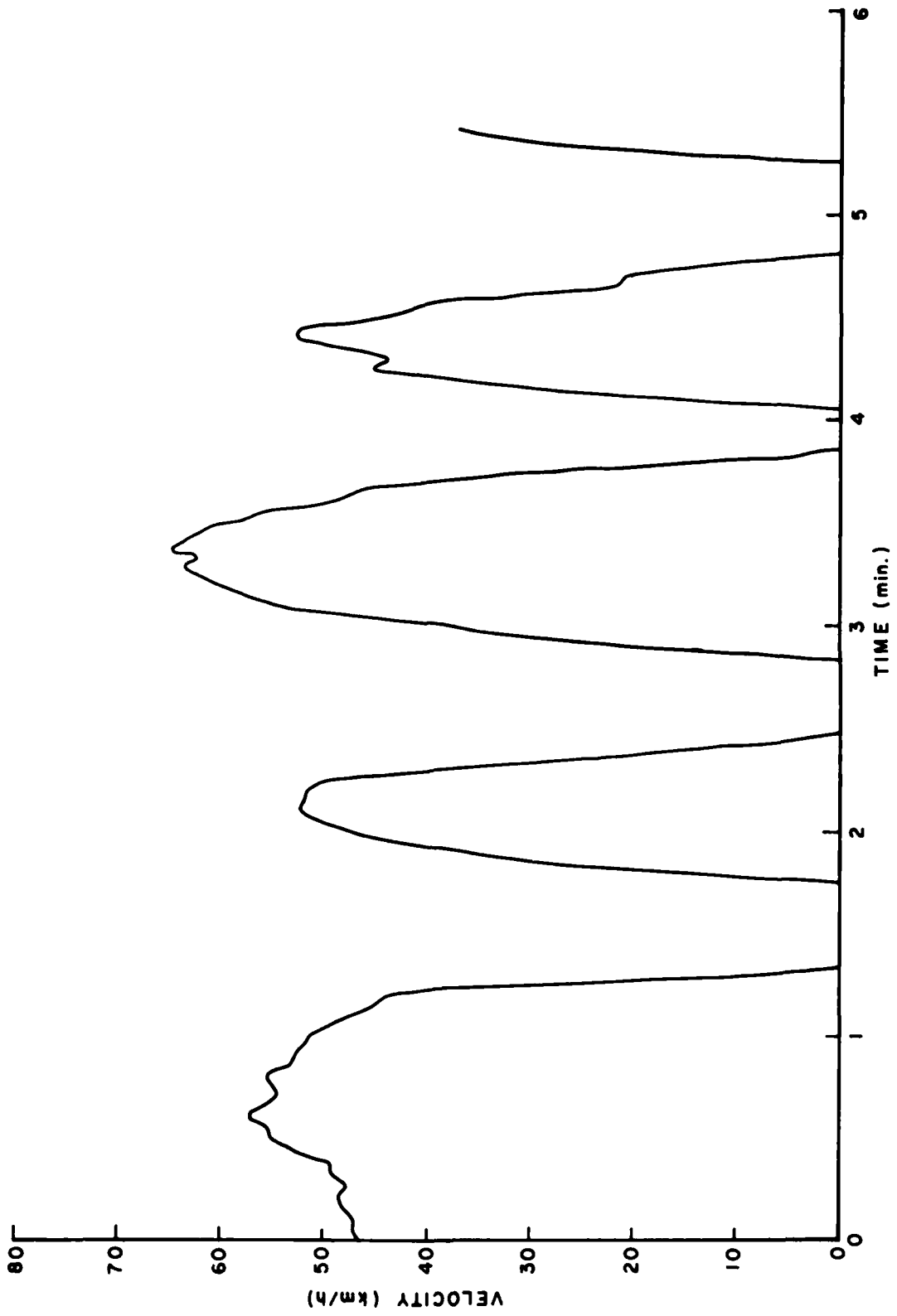

FIG. 4: VELOCITY PROFILE OF LAWRENCE AVE. W/B
RUN 20, 16:17, MAR.02.79

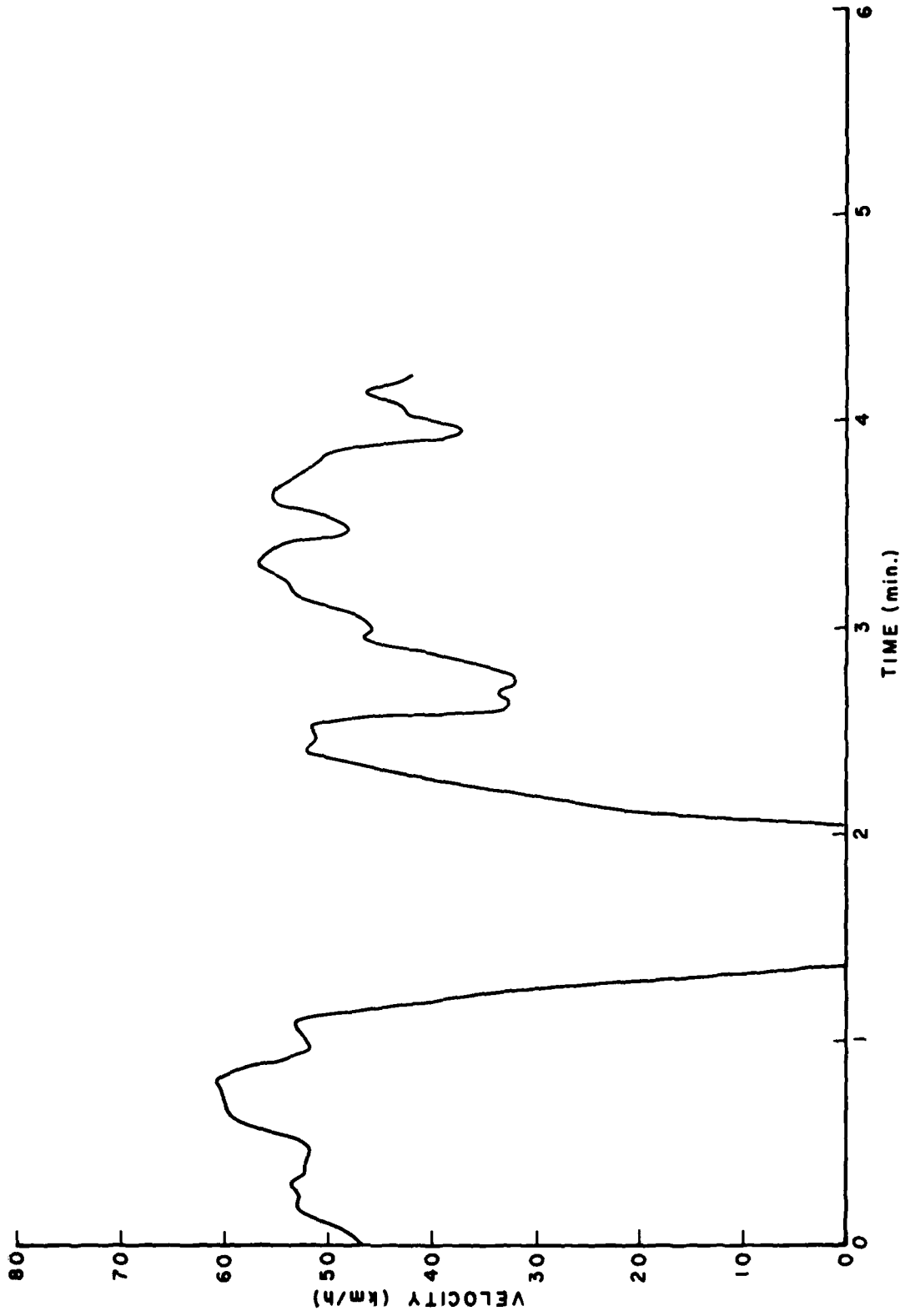

FIG. 5: VELOCITY PROFILE OF LAWRENCE AVE. E/B
RUN 21, 16:26, MAR.02.79

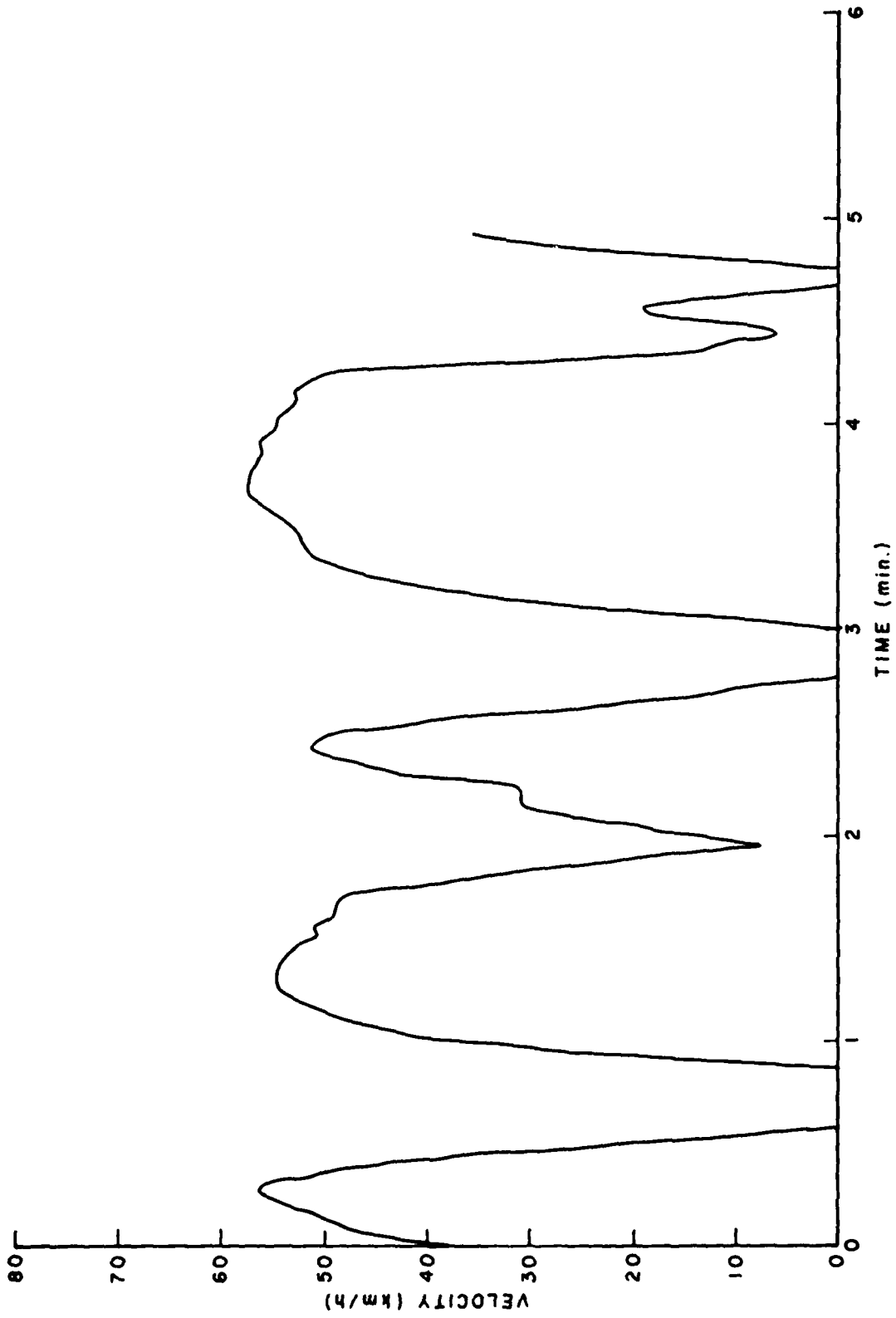

FIG. 6: VELOCITY PROFILE OF LAWRENCE AVE. E/B
RUN 1, 7:15, MAR. 05.79

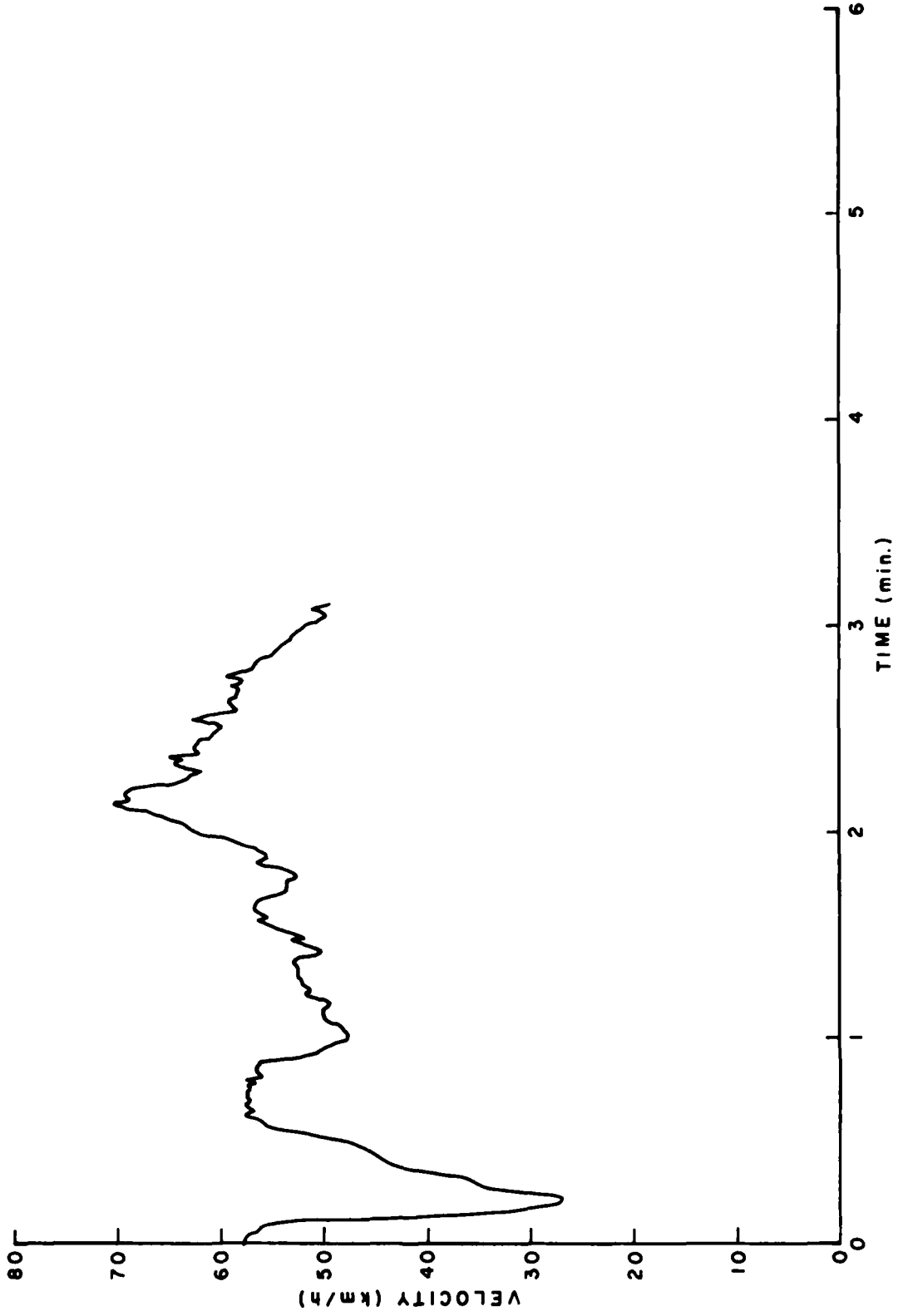

FIG. 7: VELOCITY PROFILE OF LAWRENCE AVE. W/B
RUN 2, 7:28, MAR.05.79

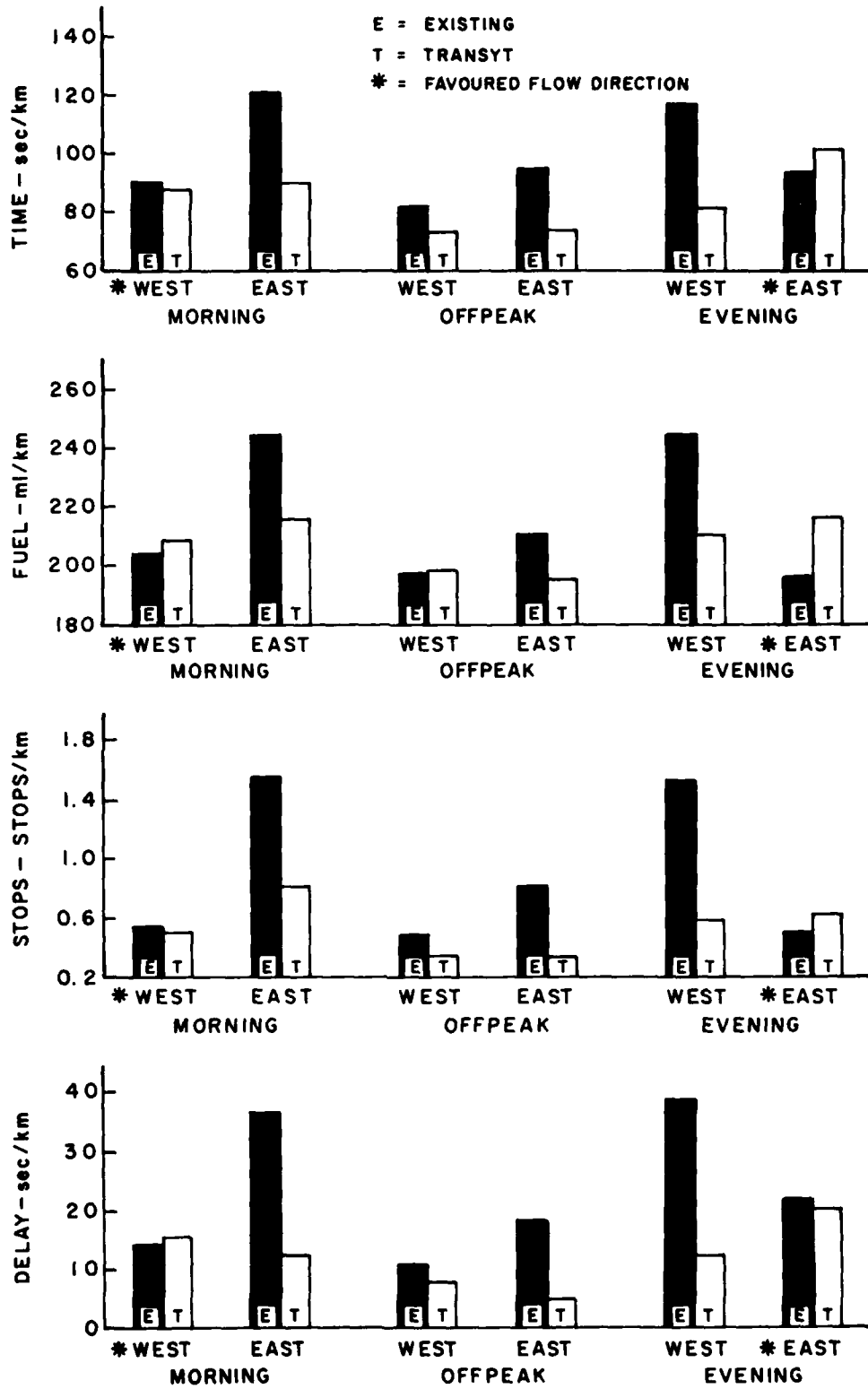

FIG. 8: MEAN VALUES OF TIME, FUEL, STOPS AND DELAY

CURRENT PROJECTS

Much of the work in progress in the laboratories of the National Aeronautical Establishment and the Division of Mechanical Engineering includes calibrations, routine analyses and the testing of proprietary products; in addition, a substantial volume of the work is devoted to applied research or investigations carried out under contract and on behalf of private industrial companies.

None of this work is reported in the following pages.

ANALYSIS LABORATORY

AVAILABLE FACILITIES

This laboratory has analysis and simulation facilities available on an open-shop basis. Enquiries are especially encouraged from industry for projects that may utilize the facilities in a novel and/or particularly effective manner. Such projects are given priority and are fully supported with assistance from laboratory personnel. The facilities are especially suited to system design studies and scientific data processing. Information is available upon request.

EQUIPMENT

An Electronic Associates 690 HYBRID COMPUTER consisting of the following:

- (a) PACER 100 digital computer
 - 32K memory
 - card reader
 - high speed printer
 - disc
 - digital plotter
 - Lektromedia interactive terminal
- (b) Two EAI 680 analogue computer consoles
 - 200 amplifiers including 60 integrators
 - 100 digitally set attenuators
 - non-linear elements
 - x-y pen recorders
 - strip chart recorders
 - large screen oscilloscope
- (c) EAI 693 interface
 - 24 digital-to-analogue converters
 - 48 analogue-to-digital converters
 - interrupts, sense lines, control lines

Dual channel real time portable spectrum analyser, Hewlett Packard Model 3582A. Bandwidth 0.02 to 25.5 Hz. Built-in periodic and random sources for transfer function and transient signal analysis.

GENERAL STUDIES

A microprocessor-based function generator for the hybrid computer is being designed. A TI 9900 development system has been obtained to be used for the project.

A study is being made on the use of topological methods to describe and analyze complex systems.

APPLICATION STUDIES

Aviation Electric Ltd. hybrid computer modeling work is continuing in support of their advanced control concepts for both the small business jet engine and the helicopter engine. GasTOPS Ltd. are collaborating with AEL.

Canadian Westinghouse Ltd. are continuing a study of fuel controller requirements for a new family of industrial gas turbines. A hybrid computer model is being used to evaluate control system hardware.

In collaboration with Kendall Consultants Ltd., and SPAR Aerospace Products Ltd., a hybrid computer model of the remote manipulator arm for the space shuttle is being assembled. The model includes all allowable motions in three dimensions as well as arm flexibility effects. The three dimensional model is complete. Arm control algorithms and joint control parameter sensitivity have been evaluated.

In collaboration with the Railway Laboratory, a pilot hybrid computer model of the NRC roller rig for railway vehicle testing is being used as an aid in the design of the roller rig and its controls.

In collaboration with the Control Systems and Human Engineering Laboratory and the International Nickel Co., Ontario Division, an interactive computer model of a copper-nickel smelter is being developed to study material handling and scheduling in the plant.

In collaboration with DME Engine Laboratory a hybrid computer model of an air cushion vehicle is being assembled.

In collaboration with DME Engine Laboratory analysis of fuel consumption and travel time of test cars with two computer controlled traffic light sequencing plans.

In collaboration with Glenayre Electronics Ltd. and Lornex Mines a computer model of open pit mining operations is being developed for use in the design and evaluation of a truck dispatching system.

Carleton University and Engine Laboratory are collaborating on a study of a heavy equipment propulsion system using a co-rotating compressor.

In collaboration with Stephens-Adamson of Belleville a hybrid computer model of long conveyor belts is being assembled.

In collaboration with Davis Eryou and Associates a hybrid computer model of an automobile is being assembled.

Nican Corp. and GasTOPS Ltd. are using a hybrid computer model to study the use of a variable flow pump to improve solar hot water heating systems.

Davis Eryou and Associates are assembling a computer aided design package for Solar Heating Systems under contract to the NRC Energy Project.

Two PILP contracts are under way to conduct a market survey and feasibility study for a commercial hybrid computer simulation facility.

Kendall Consultants Ltd. have completed preliminary study for Guildline Instruments Ltd. on their Batfish cable-towed oceanographic survey system.

Arctec Canada Ltd. are using the hybrid computer for Icebreaker Data Analysis.

SYSTEM SOFTWARE STUDIES

A preprocessor for hybrid computer model digital programs.

Character string manipulation routines to be used in a Fortran environment.

CONTROL SYSTEMS AND HUMAN ENGINEERING LABORATORY

INDUSTRIAL CONTROL PROBLEMS

In collaboration with the Analysis Laboratory interactive computer models are being developed and applied to a variety of scheduling and materials handling projects in the mining and metal processing industries.

Application of microprocessors to improve quality, performance and efficiency in the metal forming industry is currently being undertaken in collaboration with a Canadian company.

To study distributed process control a network software system (DECNET) is being installed to connect together the PDP-11/45 and PDP-11/60 computers in the Laboratory. Also, a serial communication system based on the HDLC line protocol is being implemented with microprocessors. This activity is proceeding in parallel with the development of an international standard for industrial intersubsystem communication.

A flowmeter, viscometer, consistency sensor and control valve utilizing radial laminar flow have been developed and patented. The devices, currently under test for industrial application, are mechanically simple and have a minimum of machining tolerances. They offer significant advantages over those currently available in that the maintenance of laminar flow provides quiet operation while allowing accurate performance production.

Fluidic and electromagnetic overspeed control systems for a two-stroke internal combustion engine are being developed in collaboration with a Canadian manufacturer.

ADVANCED TRANSPORTATION CONCEPTS

The conceptual design for a high speed intercity magnetically levitated and linear synchronous motor propelled vehicle plus elevated guideway system as based on the results of a basic Maglev research program jointly conducted by Queen's University, University of Toronto and McGill University has been carried out in collaboration with Transport Canada. Ongoing study includes computer modeling for ride quality assessment, vehicle dynamic behaviour prediction and engineering design consideration of the magnets.

HUMAN ENGINEERING - BEHAVIOURAL STUDIES

The investigation of the effect of internal and external environments on human psychomotor performance continues and includes the study being conducted in collaboration with the Indian Air Force on the psychomotor performance of aircrew on long range flights.

Tracking experiments have been designed and initiated in the series dealing with precision of movement to a target. These are further tests of the hypothesis that subjects move in a frame of reference based on proprioceptive rather than visual information.

HUMAN ENGINEERING - MEDICAL AND SURGICAL

The surgical team involved in the application of spinal cord cooling has moved from the Montreal Neurological Institute to McMaster University, Hamilton.

The R&D program on controlled cooling is continuing as before in association with the Control Systems and Human Engineering Laboratory and with the Department of Anatomy, Queen's University.

A prototype model miniature instrument for measuring the viscoelastic properties of skin is being developed.



**TEST VEHICLE FOR AERODYNAMIC AND PERFORMANCE STUDIES OF
AUTOMOTIVE COOLING SYSTEM COMPONENTS**

**THIS VEHICLE HAS BEEN INSTRUMENTED WITH SURFACE PRESSURE TAPS FOR
AERODYNAMIC STUDIES IN THE NAE 30 X 30 FT. WIND TUNNEL**

**ENGINE LABORATORY
DIVISION OF MECHANICAL ENGINEERING**

ENGINE LABORATORY

HOSPITAL AIR BED

Field trials with the NRC Mark I Cairbed in the Burns Unit of the Hotel Dieu Hospital in Kingston, Ontario, have been completed after one year of continuous service.

Many advantages over standard support methods have been demonstrated, most notably a better rate of epithelial repair. The chief drawback of the experimental unit placed in Kingston has been its noise.

Because it has not been possible to quantify rate of epithelial repair, further field trials will be necessary in order to build up additional case histories. To meet this objective, the Mark I Cairbed will be replaced with two new experimental NRC Cairbeds in participating hospitals. These patient support systems are now being designed.

AUTOMOTIVE ENGINE COOLING SYSTEM PERFORMANCE

In collaboration with Canadian automotive industry and with financial support by Transport Canada the Division of Mechanical Engineering is doing research to try to improve fuel economy through better use of cooling fans. The specific objective will be to reduce the total power draw by controlling the interaction between the cooling fan and the external vehicle aerodynamics.

A suitable test vehicle has been provided by industry and this car is being instrumented for road and wind tunnel test work.

The test vehicle carries an on-board data acquisition system to record vehicle surface pressures and cooling air path performance variables. Testing in the 30 x 30 NAE wind tunnel will commence in January 1980.

HYDROSTATIC BEARINGS

Assistance and design services have been given to potential gas and fluid film bearing users both within NRC and in other government laboratories.

ROTOR DYNAMICS

Concrete and floor steel work have been finished for the large rotor dynamics and balancing facility. Equipment acquisition is continuing. Rotors up to 6 m. in length and 2 m. in diameter will be accommodated. Installed drive motors have a capacity of 1200 hp. Eventually, the test chamber will be capable of operating at reduced pressures allowing bladed rotors to be tested without serious power dissipation.

In-house computer programs for the calculation of critical speeds and unbalance response continue to be used on request from internal and external sources.

VIBRATION MONITORING

An experimental rig has been assembled to allow the testing of rolling element bearings to failure. This rig is now being used to compare current methods of vibration detection and their ability to discover incipient faults in rolling element bearings. Because of the nature of fault generation in rolling element bearings the result gathering process is of a rather long-term nature.

A co-operative program with the Defence Research Establishment (Pacific) in Victoria is underway to investigate the combined merits of oil analysis and vibration monitoring as tools for helicopter transmission gear box monitoring.

ACOSTICS

Experiments were completed to check the computational methods being developed for propagating modes in ducts based on sound pressure level around the circumference of the duct using cross spectral density and phase-locked methods.

Analysis is continuing of experimental data of an improved technique for noise source identification in small reciprocating engines.

AUTOMOTIVE FUEL ECONOMY

The report on the effect of traffic signal control strategy on automotive fuel consumption is at the publications department. Further regression analysis of delay time showed very little to be gained by its inclusion in the multivariate regression. The best correlation in calculated fuel consumption was found by combining stops/km and travel time in sec./km. Each of the variables - delay, stops or travel time could be used singly but would explain less of the variance in calculated fuel consumption than the above two.

AIR CUSHION VEHICLES

A study on the drag and stability of low speed AC rafts has been completed, except for outdoor experiments next spring. A report is in preparation. A program of studies on the vertical instability (heave) of ACVs is commencing with particular reference to the design and operation of high cushion pressure transporters and very large AC rafts.

GAS TURBINE OPERATIONS

J85-CAN-15 gas turbine studies were continued. Test results on a limited series of T5 amplifiers of the fuel control system were evaluated and reported on. An assessment was made of the proper functioning of the Check Delay and Ramp Valve.

FUEL CONTROL SYSTEMS

After completion of the basic Twin Pac installation, preliminary testing commenced for the purpose of checking out the engine's controls and steady-state operation. In addition, the dynamometer's performance map was explored, with special interest in its control range and sensitivity.

GAS TURBINE ICING TESTS

For the upcoming icing season, preparations began for icing tests on two Pratt & Whitney Aircraft of Canada PT6 installations. Under test will be a PT6A-65/Beech "King Air" anti-icing system and a full-scale model of a PT6A-27 in an Embraer 312 nacelle inlet.

NRC-PRATT & WHITNEY HIGHLY LOADED TURBINE

Preliminary tests have been conducted at rotor speeds up to 2000 rpm to examine the controllability of the dynamometer loading system. Higher speeds will be attempted with the new flexible shaft which will couple the turbine to the dynamometer. Installation of instrumentation is continuing.

FLIGHT RESEARCH LABORATORY

AIRBORNE MAGNETICS PROGRAM

Experimental and theoretical studies relating to the further development of airborne magnetometer and gradiometer equipment and their application to submarine detection and geological survey, are currently in progress. The final report on methods of magnetic aircraft compensation, based on data collected with the North Star aircraft, has been published. The Convair 580 aircraft has been equipped as a multi-purpose flying laboratory for research in aeromagnetic detection and for development of radio and inertial navigation methods. In particular, airborne testing is well under way towards the mechanization of a three-axis magnetic gradiometer. Further modifications may be done to provide a capability for evaluating advanced synthetic aperture radar techniques.

INVESTIGATION OF PROBLEMS ASSOCIATED WITH STOL AND V/STOL AIRCRAFT OPERATIONS

The Laboratory's Airborne V/STOL Simulator is being employed in programs to investigate STOL and V/STOL aircraft flying qualities and terminal area operational problems. Areas of research include an assessment of advanced, integrated cockpit control configurations for helicopters, the identification of minimum acceptable flying qualities for civil helicopters operating under instrument flight rules, and an investigation of flight path control and stability characteristics required to compensate for single engine failure in powered-lift aircraft.

INVESTIGATION OF ATMOSPHERIC TURBULENCE

A T-33 aircraft, equipped to measure wind gust velocities, air temperature, wind speed, and other parameters of interest in turbulence research, is used for measurements at very low altitude, in clear air above the tropopause, in the neighbourhood of mountain wave activity, and near storms. Records are obtained on magnetic tape to facilitate data analysis. The aircraft also participates in co-operative experiments with other research agencies, in particular, the Summer Cumulus Investigation (see below). A second T-33 aircraft is used in a supporting role for these and other projects.

AIRCRAFT OPERATIONS

The Flight Recorder Playback Centre is engaged in the recovery and analysis of information from the various flight data recorders and cockpit voice recorders used on Canadian military and civil transport aircraft. The military systems are being monitored on a routine basis. Civil aircraft recorders are being replayed to investigate incidents or accidents at the request of the Ministry of Transport. Technical assistance is being provided during incident and accident investigations and relevant aircraft operational problems studied.

INDUSTRIAL ASSISTANCE

Assistance is given to aircraft manufacturers and other companies requiring the use of specialized flight test equipment or techniques.

INVESTIGATION OF SPRAY DROPLET RELEASE FROM AIRCRAFT

Theoretical and experimental studies on spray droplet formation and distribution are carried out. Flight experiments utilize a Harvard aircraft modified to carry external spray tanks. Automatic flying spot droplet and particle analysis equipment is in operation for processing samples obtained in the laboratory and in the field by various agencies. The equipment has potentialities for the analysis of many unusual configurations provided that these may be photographed with sufficient contrast.

AUTOMOBILE CRASH DETECTOR

There is a need for a sensing device to activate automobile passenger restraint systems in incipient crash situations. Investigations are in progress to determine the applicability of C.P.I. technology to this problem.

SUMMER CUMULUS INVESTIGATION

At the request of the Department of the Environment flight studies of Cumulus cloud formations over Quebec and Ontario were instituted during the Summer of 1974. Instrumented T-33 and Twin Otter aircraft with a Beech 18 are being used to determine the properties of Cumulus clouds which extend appreciably above the freezing level. The measurements are being made to assess the feasibility of inducing precipitation over forest fire areas by seeding large cumulus formations. During 1975 a variety of cloud physics instruments were added to the Twin Otter, and special pods for burning silver iodide flares were attached beneath the wing of the T-33 turbulence research aircraft. The effects of seeding on the microstructure of individual cumulus clouds were studied in the Yellowknife area during the summers of 1975 and 1976 and in Thunder Bay in 1977 and 1978. During the summer of 1979 the Twin Otter participated in similar flight experiments in Montana, jointly arranged by U.S. and Canadian government agencies.



**AN ADVANCED COCKPIT CONTROL CONFIGURATION WHICH IS BEING
EVALUATED IN FLIGHT USING THE NAE AIRBORNE V/STOL SIMULATOR**

**FLIGHT RESEARCH LABORATORY
NATIONAL AERONAUTICAL ESTABLISHMENT**

FUELS AND LUBRICANTS LABORATORY

COMBUSTION RESEARCH

Investigation of handling and combustion problems involved in using hydrogen as a fuel for mobile prime movers.

Biogas as an alternate fuel in engine operation.

EXTENSION AND DEVELOPMENT OF LABORATORY EVALUATION

Development of new laboratory procedures for the determination of the load carrying capacity of hypoid gear oils under high speed conditions and under low speed high torque conditions.

Water separation characteristics of aviation turbine fuels.

PERFORMANCE ASPECTS OF FUELS, OILS, GREASES, AND BRAKE FLUID

Investigation of laboratory methods for predicting flow properties of engine and gear oils under low temperature operating conditions.

Evaluation of static dissipator additives for distillate fuels.

Evaluation of Properties of re-refined base oils and recycled industrial oils.

Properties of summer and winter unleaded motor gasolines.

Properties of Canadian, USA and USSR car founal box oils.

Road test of re-refined automotive oils (co-operation with Environment Canada).

Investigation of the use of anti-icing additive in aviation gasoline.

Investigation of hydrogen content as a means of estimating the combustion characteristics of aviation turbine fuels.

Co-operative studies with Working Group 13 of AGARD Propulsion and Energetics Panel on performance aspects of future aviation fuels.

MISCELLANEOUS STUDIES

Investigation of the stability of highly compressed fuel gases.

Analytical techniques for analysis of engine exhaust emissions.

Participation in the Canadian (CGSB), American (ASTM) and International (ISO) bodies to develop standards for petroleum products and lubricants.

The design and development of an internal combustion engine/hydraulic transmission hybrid power plant for the energy conserving car.

Further developments of specialized pressure transducers for engine health diagnosis and the development of diagnostic techniques and consultation with licensee in developing production methods for patented transducers.

Evaluation of various products, fuels, lubricants and hardware in respect of their effects upon overall vehicle fuel economy and energy conservation properties.

GAS DYNAMICS LABORATORY

V/STOL PROPULSION SYSTEMS

A general study of V/STOL propulsion system methods with particular reference to requirements of economy and safety.

INTERNAL AERODYNAMICS OF DUCTS, DIFFUSERS AND NOZZLES

An experimental study of the internal aerodynamics of ducts, bends, diffusers and nozzles with particular reference to the effect of entry flow distortion in geometries involving changes of cross-sectional area, shape, and axial direction.

SHOCK PRODUCED PLASMA STUDIES

A general theoretical and experimental investigation of the production of high temperature plasma by means of shock waves generated by electromagnetic and gas dynamic means, and the development of diagnostic techniques suitable for a variety of shock geometries and the study of physical properties of such plasmas.

NON-DESTRUCTIVE SURFACE FLAW DETECTION IN HOT STEEL BILLETS

A flaw detection system for metal bars is being tested. Eight inductive bridge circuits, spaced around the bar and sequentially sampled, detect the flaw through a change in coil inductance. The system lends itself to easy elimination of stand-off and eccentricity errors and is currently being adapted to industrial use. Interpretation of test results via microprocessors is in hand. A rugged, heat-resistant circuit is being designed for in-plant application.

HARD SURFACE PLATING

The high temperature, high speed plasma flow generated by a high voltage, capacitive discharge in a pulsed plasma gun is used to melt and propel various powders in thermal spraying applications. Coatings obtained to date are similar to those applied with conventional means. The powder acceleration in the gun and impact on the substrate is presently being studied using a laser, with the aim of improving the process.

HIGH PRESSURE LIQUID JETS

High speed water jets generated by pressures in the range of 1000 to 60,000 psi can be used for cutting a wide variety of materials, e.g. paper, lumber, plastics, meat, leather, rock, etc., and for cleaning surfaces such as masonry, tubular heat exchangers, etc. Nozzle sizes, depending on the application, are in the range from 0.002 to 0.15 in. diameter. A technique for manufacturing small nozzles in the range 0.002 to 0.015 has been developed using standard sapphire jewels available from industry. Larger orifices are manufactured and polished using standard shop procedures.

At present, the following investigations are active in the laboratory:

1. Drilling of rocks of various types, including granite, using a high pressure rotating seal and single and dual orifice nozzles specially developed for this purpose.
2. Study of the effects produced by cavitating jets, how best to produce them and where they may be usefully applied.
3. Collaborative experimental work, in collaboration with the Low Temperature Laboratory, on the breaking and cutting of ice.

HEAT TRANSFER STUDIES

An investigation of methods of increasing boiling and condensing heat transfer coefficients by treatment of the heat transfer surface is in progress.

A co-operative project with the Division of Building Research will determine the usefulness of the thermosiphon as a ground heat source for a heat pump.

An inexpensive, leakproof heat exchanger has been developed for use in solar energy and heat pump systems. Fabrication is simple and it is suitable for production in small batches.

Work has started on a new type of temperature control thermosiphon. Previous types have been designed to control the temperature of a heat source; this design controls the temperature of a heat sink.

COMPUTATIONAL FLUID DYNAMICS

Numerical simulations are carried out in connection with projects initiated internally or as collaborations with outside organizations. Present studies involve problems of the absorption of laser energy by plasmas and the dynamics of plasmas under three dimensional magnetic compression. The main topics pursued currently are:

1. Absorption of laser energy by hydrogen plasma confined by a magnetic field (laser heated solenoid).
2. A study of the fluid mechanics accompanying continuous discharge of laser energy into a spot fixed in space.
3. Laser-initiation of a high-density Z-pinch.
4. Static and dynamic equilibria of plasma in a spherical θ -pinch device.

GAS TURBINE BLADING STUDIES

A theoretical and experimental study of the performance of highly loaded gas turbine blading has been undertaken as a collaborative program with industry and universities.

INDUSTRIAL PROCESS, APPARATUS, AND INSTRUMENTATION

There is an appreciable effort, on a continuing basis, directed towards industrial assistance. This work is of an extremely varied nature and, in general, requires the special facilities and capabilities available in the laboratory.

Current and recent co-operative projects with manufacturers and users include:

- (a) Flow problems associated with industrial gas turbine exhaust systems (Foster Wheeler).
- (b) Combustion studies for industrial gas turbine applications (Westinghouse and Rolls-Royce).
- (c) Application of thermosiphon as an energy conserving device in industrial applications (Dept. of Agriculture, Ministry of Transport, Farion Electric, Chromalox Canada Ltd.).
- (d) Scaled model studies on steel and copper converters to establish relative performance and ceramic liner deterioration rates (Canadian Liquid Air and Noranda).
- (e) High pressure water jet applications in industry (High Pressure Systems Ltd.).
- (f) Scaled model studies to establish the performance of complex industrial flue systems with a view to establishing specific design and performance criteria. (Noranda and Inco Canada Ltd.).
- (g) Model studies of internal flows in reactor hood and waste heat boiler (Noranda and Kennecott Copper Corp.).
- (h) Altitude test chamber for small gas turbines (Pratt & Whitney Aircraft of Canada Ltd.).
- (i) Experimental study of a novel fan design (Rolls-Royce).

HIGH SPEED AERODYNAMICS LABORATORY

DATA SYSTEM IMPROVEMENTS ON 5-FT. X 5-FT. WIND TUNNEL

The new PDP 11/t55 based data acquisition has now been installed, replacing a 9-year-old DDP-516 system. Initial tests went extremely smoothly, and customers from industry are now utilizing the system in a manner similar to the old one, with enhanced performance. Extra flexibility in programming tests through use of real-time tunnel control, event sequencing, model attitude and data acquisition is proving easy to use and attractive to customers. The main problem has been one of staff training in a complex new environment with vastly enhanced capabilities.

Improved 'quick-look' programs plot data in uncorrected coefficient form within a few minutes of a run.

A total of up to 96 analog channels (48 high quality and 48 lower quality) are available, with switch selected gains of 1 to 5000 and front end filters of 3 Hz to 10 kHz. "Status" channels are now digitized at source and packed to minimize data volumes.

Data conversion throughputs have been demonstrated at 40 kHz average with bursts of 100 kHz rates through two 15-bit A/D converters simultaneously.

Real-time tunnel control, model attitude and data acquisition tasks are performed in the same processor through software, utilizing tables prepared in advance to define the various operations required.

Progress toward on-line data reduction is proceeding.

CALIBRATION OF TRANSONIC SECTION IN HALF-MODEL GEOMETRY

Calibration of the empty transonic 5-ft. X 5-ft. section in half-model geometry is completed. Static pressure measurements along the ceiling, floor and reflection plate were made at three stagnation pressures in the Mach number range $0.3 < M < 0.99$. Preliminary results indicate that in the region extending 10 inches forward and aft of the balance centre there is little or no Mach number gradient and little or no difference between the static pressures measured in the plenum chamber and in the working section. The test results are documented in LTR-HA-5 X 5/0125 to be published shortly. Further tests are being planned to measure the extent of the boundary layer on the reflection plate. The effect of thermal shock on the outputs of the half-model balance will be conducted in January, 1980.

TRANSONIC EQUIVALENCE RULE INVOLVING LIFT

The classical area rule is well known and its application to wing-body design and drag reduction is demonstrated on many existing aircraft. Recent advances in transonic aerodynamic theory show that the classical area rule requires a modification to account for lift. A series of experiments is being prepared in order to investigate these new concepts. The results of these experimental studies will provide criteria for wing-body design with emphasis on drag reduction for aircraft cruising at transonic speeds. In conjunction with the experimental studies, computational methods have been developed to calculate the flow field around slender aircraft with lift at transonic speeds.

TWO-DIMENSIONAL TRANSONIC FLOW STUDIES

The small disturbance transonic computer program, developed for analysis of isolated airfoils, have been extended to an inverse design method.

STUDIES OF WING BUFFETING

A theoretical study of the transient response of a wing to non-stationary buffet loads is in progress. Various forms of the power spectral density of the aerodynamic loading on the wing have been considered for a number of load versus time history during buffet manoeuvres. A wind tunnel investigation of the surface pressure and normal force fluctuations associated with buffeting has been carried out on the BGK No. 1 airfoil.

REYNOLDS NUMBER EFFECTS ON TWO-DIMENSIONAL AEROFOILS WITH MECHANICAL HIGH LIFT DEVICES

Under a joint NRC/de Havilland enterprise administered under the PILP program an extensive set of low speed aerodynamic measurements were made in the 2-D insert in the period September 26 - November 30, 1978, on a multi-component aerofoil model.

During the first phase of the work several trailing-edge flap geometries (with and without a leading-edge slat) were optimized at a chord Reynolds number of 6×10^6 ; subsequently their performance at lower and high Reynolds numbers were checked.

REYNOLDS NUMBER EFFECTS ON TWO-DIMENSIONAL AEROFOILS WITH MECHANICAL HIGH LIFT DEVICES (Cont'd)

In a second phase of tests with this aerofoil some boundary layer measurements were made near the trailing-edge of the main element, utilizing a new boundary-layer traversing rig. These latter measurements were primarily directed at checkout of the traversing rig in its simplest form, with the objective of developing reliable gear for more extensive boundary layer measurements on high lift multi-component aerofoils in the near future.

The traversing rig has now been modified to enable boundary-layer total-pressure profiles to be measured at more than one chordwise station on the main element and also on the foreflap. In addition it will be possible to check on the flow symmetry through measurements at two or more spanwise positions.

Further measurements which had been scheduled for late 1979 are now expected to be made in March, 1980. It is proposed to examine the effect of Reynolds number (primarily) in the range 2×10^6 to 9×10^6 for various geometries involving a slat, and double-slotted trailing edge flaps. It will also be possible to examine the effect of changes in Mach number.

In a further stage of development new support arms are being constructed, which will enable measurements to be made up to (effectively) the trailing-edge of the tab-flap. Tentatively the test programme for this phase is scheduled for late 1980.

HOLE ERROR INVESTIGATION

An experimental study has been completed, in collaboration with Professor J.C. Menneron, of the University of Sherbrooke, of the effect of orifice size on the measurement of pressure on the surface of an aerofoil at subsonic free-stream velocities. Speeds up to $M = 0.7$ and chord Reynolds number from 6×10^6 to 33×10^6 were used. Orifice diameters range from 0.006 in. to 0.016 in. Analysis of the data clearly indicates that the value of the chordwise force coefficient, obtained by integration of the surface pressure, consistently increases with the size of the orifice. The effect is rather more pronounced at $M = 0.5$ and 0.7 than at $M = 0.3$.

HALF-MODEL TESTING

The effects of various leading edge droop geometries on the aerodynamic forces and moments were investigated in the range $0.3 < M < 0.975$ at $Re_c = 16$ million. The results of the test will be published in LTR-HA-5 x 5/0124.

The drag and static stability characteristics of the Saab-Scania T:m12 model were investigated in the range $0.5 < M < 0.99$ at $Re_c = 12$ million with a few isolated runs conducted at $Re_c = 18$ million. Aileron effectiveness was investigated at $0.95 < M < 0.99$. Buffet onset and intensity measurement was attempted using an accelerometer mounted close to the wing tip. The results will be published in LTR-HA-5 x 5/0125.

The drag and static stability characteristics of the FFA PT10:m5 model were investigated in the range $0.5 < M < 0.90$ at $Re_c = 12$ million with a few isolated runs conducted at $Re_c = 18$ million. Aileron effectiveness was investigated at $0.9 < M < 0.975$. The results will be published in LTR-HA-5 x 5/0126.

A joint paper with Saab-Scania and FFA on the results of the two above tests is being prepared for submission to AGARD Symposium to be held in Germany in May, 1980.

TESTS FOR OUTSIDE ORGANIZATIONS

Saab-Scania

A series of tests have been made in the 15-in. x 60-in. 2D insert to determine the two-dimensional aerodynamic characteristics of a 10% thickness/chord ratio aerofoil at subsonic speeds.

HYDRAULICS LABORATORY

ST. LAWRENCE SHIP CHANNEL

Under the sponsorship of the Ministry of Transport, a study to improve navigation along the St. Lawrence River, using hydraulic and numerical modeling techniques.

NUMERICAL SIMULATION OF RIVER AND ESTUARY SYSTEMS

Mathematical models have been developed to simulate tidal propagation in estuaries, wave refraction in shallow water and littoral drift processes. The feasibility of using array processors to solve the hydrodynamic equations is presently under study.

WAVE FORCES ON OFF-SHORE STRUCTURES

Wave flume study to determine design criteria for off-shore structures, such as cooling water intakes or outfalls, mooring dolphins, drilling rigs, etc.

RANDOM WAVE GENERATION

A study of random waves generated in a laboratory wave flume by signals from a computer. Special attention is paid to the simulation of wave groups.

STABILITY OF RUBBLE MOUND BREAKWATERS

A study to determine stability coefficients of armour units and the effect of a number of wave parameters on the stability of rubble mound breakwaters, including the effect of wave grouping.

WAVE LOADS ON CAISSON TYPE BREAKWATERS

A study to determine the overall loading, as well as the pressure distribution on various Caisson type breakwaters.

WAVE POWER AS AN ENERGY SOURCE

A general study to assess the wave power available around Canada's coast and to evaluate various proposed schemes to extract this energy. International co-operation is taking place through the International Energy Agency of OECD.

MOTIONS OF LARGE FLOATING STRUCTURES, MOORED IN SHALLOW WATER

A mathematical and hydraulic modeling program will be carried out to develop techniques and methods to forecast motions of, and mooring forces on large structures moored in shallow water.

CALIBRATION OF FLOW MEASURING DEVICES

Facilities to calibrate various types of flow meters up to a maximum capacity of 5,000 gpm are regularly used for/or by private industry and other government departments.

FIFTY MILE POINT MODEL STUDY

A hydraulic model study for Public Works, Canada of the Fifty Mile Point Marina on Lake Ontario, to investigate various layouts of breakwaters to minimize the level of wave agitation inside the basin.

TRANSPORT OF SAND ON BEACHES

A method has been developed for calculating rates of sand transport in the presence of waves, a modification of the Ackers and White method for river flows. A new flume was recently constructed in which the method can be tested.

LOW HEAD WATER TURBINES

A research program has been started to investigate the feasibility of extracting power from water currents, by using low head turbines.

HYBRID MODELING TECHNIQUES USING ARRAY PROCESSORS

Estuaries where tidal power can be developed require the use of large physical models of the area. The laboratory has demonstrated that a "hybrid model" can dynamically couple together a mathematical model to the physical model at the boundaries, therefore the physical model need not be very large in extent. An array processor will be used to realize the mathematical portion of the hybrid model.

STONEHAVEN HARBOUR STUDY

A hydraulic model study by Public Works Canada of Stonehaven Harbour, N.B. to investigate various changes to the existing breakwaters to reduce the level of wave agitation inside the harbour basin.

LOW SPEED AERODYNAMICS LABORATORY

WIND TUNNEL OPERATIONS

The three major wind tunnels of the laboratory are the 15-ft. diameter open jet vertical tunnel, the 6-ft. X 9-ft. closed jet horizontal tunnel and the 30-ft. X 30-ft. V/STOL tunnel. During the quarter, a number of test programs were carried out for groups both within and outside the government. Within the government, test programs included studies on building aerodynamics and transport trucks. Studies for non-government groups included the aerodynamics of road vehicles, two aircraft models, a horizontal axis and a vertical axis windmill and an aircraft insecticide spray-boom system.

Software development is continuing for the new data acquisition, reduction and control system for the 6-ft. X 9-ft. wind tunnel.

WIND ENGINEERING

A joint NRC/Transport Canada - DOT/SAE (USA) wind tunnel test program continued on truck energy conservation through drag reduction. As part of a comparative series in five different wind tunnel facilities tests were completed at General Motors Research wind tunnels on four 1:10 scale truck models. Tests at NAE, the University of Maryland and California Institute of Technology were completed earlier and the next phase is at Purdue University.

A site visit was made to Lions' Gate Bridge, Vancouver, to change the alignment and make repairs to anemometers mounted on the bridge. In addition, a temperature sensor was installed. Outputs from five anemometers, two accelerometers and the temperature sensor are recorded by an automated system, site assistance being provided by Buckland and Taylor Ltd., Vancouver and the NRC Vancouver Lab.

The wind patterns over a 1:500 scale topographical model of the Atlantic Wind Test Site, Prince Edward Island, were investigated in the NAE 2 m X 3 m wind tunnel. The work was for the Institute of Man and Resources, Prince Edward Island.

Measurements of pressure fluctuations in grain elevator weigh scales at the Port of Montreal were made for the National Harbours Board. Analysis of the results enabled the contribution of the pressure fluctuations to weighing errors to be calculated.

Development of a surface mounted pressure device for measuring street level winds on a city model continued in the NAE 1 m X 1 m wind tunnel. The device connects to a pressure transducer and scanivalve and allows street level winds to be measured rapidly at a large number of locations.

A study of street level winds in the downtown core of the City of Ottawa is continuing. The first phase is to establish a probability distribution of the existing wind climate and the second phase is the simulation of the wind conditions using a 1:400 scale model in the NAE 9 m X 9 m wind tunnel. The study is jointly sponsored by the City of Ottawa, the Department of Public Works, the National Capital Commission and the National Aeronautical Establishment. A preliminary wind tunnel test has been completed on the 1:400 scale model and remote wind sensing units have been received and are being installed.

Measurements of the hydrodynamic loads to be expected on the active roll control fin stabilizers for a proposed new coastal patrol frigate were made for Defence Research Establishment Atlantic in the NAE 2 m X 3 m wind tunnel. A 1:35 scale model of the below water-line hull shape was mounted in the inverted position on a ground board. The fin was attached to a 3-component strain gauge balance from which measurements of fin lift, drag and pitching moment were made. Measurements in the wake of a 1:4 scale model of a stabilizer fin are being made to investigate the effect of fin position on the relative interferences of fin, bilge keel and propeller wakes. The wake flow field measurements are being made with a rake of 18 five-hole yaw probes.

An investigation was carried out, in co-operation with Dilworth, Secord, Meagher and Associates, Toronto, on the effectiveness of slotted walls in reducing blockage effects on vehicles models. Tests were completed in the NAE 2 m X 3 m and 1 m X 1 m wind tunnels.

Analysis was completed of the results of a snow drifting study on a 1:300 scale model of the Montreal Olympic Stadium. The model was constructed at NAE and tested during the previous quarter in a snow simulation wind tunnel at Carleton University.

FLUIDICS

Co-operative studies with D.G. Instruments of a 3-axis velocity sensor are continuing using both NRC and industry developed concepts. Studies of vortex excitation of velocity sensor probes have been carried out in co-operation with Fluidynamics Devices Ltd. A program of applications of laminar flow in thin passages is being carried out in co-operation with the Control Systems and Human Engineering Laboratory of DME.

VERTICAL AXIS WIND TURBINE

In July 78, the rotor of the 230-kW demonstrations wind turbine on the Magdalen Islands collapsed while the drive train was undergoing maintenance. An investigation of the causes of the accident uncovered no basic flaw in its design or construction.

VERTICAL AXIS WIND TURBINE (Cont'd)

Therefore, it was decided to rebuild it. A new rotor has been installed and the turbine is expected to be in operation by end of January. Two 50 kW wind turbines were installed (in 1978) and connected to local power networks in Newfoundland and Saskatchewan. The Newfoundland turbine has been in operation for over a year. The turbine in Saskatchewan suffered a bearing failure last summer and is being repaired.

Two more 50 kW turbines are on order for delivery early 1980. One of these will be operated in Churchill, Manitoba and the other near Victoria, British Columbia.

Twenty wind speed measurement and recording systems have been ordered. These systems will be installed at possible future sites for wind turbines identified by utility companies - to better assess the wind power potential of these sites.

LOW TEMPERATURE LABORATORY

THERMAL PROTECTION OF TRACK SWITCHES

The use of heat to eliminate switch failures from snow and ice is a standard approach to this problem. Work has been carried out on improving the efficiency of forced convection combustion heaters and the means of distributing heat to the critical areas of a switch.

HORIZONTAL AIR CURTAIN SWITCH PROTECTOR

A non-thermal method of protecting a switch from failure due to snow has been undergoing development and evaluation. This method consists of high velocity horizontal air curtains designed to prevent the deposit of snow in critical areas of a switch. The tests conducted to date are especially encouraging with respect to yards and terminals. Additional evaluation is required for the line service application.

NEW RAILWAY SWITCH DEVELOPMENT

The ultimate solution to the existing problem of snow and ice failure of the point switch would appear to be replacement by a new design that is not subject to failure in this way. A switch has been designed, fabricated, laboratory tested and has now completed one winter season of field trials. The design involves only shear loading from snow and ice.

MISCELLANEOUS ICING INVESTIGATIONS

Analytical and experimental investigations of a non-routine nature, and the investigation of certain aspects of icing simulation and measurement.

TRAWLER ICING

In collaboration with Department of Transport, an investigation of the icing of fishing trawlers and other vessels under conditions of freezing sea spray, and of methods of combatting the problem.

AIRBORNE SNOW CONCENTRATION

To provide statistical data on the airborne mass concentration of falling snow in order to define suitable design and qualification criteria for flight through snow, measurements of concentration and related meteorological parameters are being made.

SEA ICE DYNAMICS

Analytical and experimental work on the techniques of forming low-strength ice from saline solutions is being carried out in connection with proposed modeling studies of icebreaking ships and arctic port facilities.

An investigation is being made into the modeling of sea ice based on the freezing of aqueous solutions. The objective of the investigation is to improve the dynamic similarity in model testing in simulated sea ice.

LOCOMOTIVE TRACTION MOTORS

An investigation into the failure of locomotive traction motor support bearings due to winter service has been undertaken. The presence of moisture either as water or ice in the oil reservoirs is suspected to be a contributing cause of the failures.

HIGH PRESSURE CUTTING OF ICE

Experimental work is being carried out in collaboration with Gas Dynamics personnel on the cutting of ice with high pressure water jets. One phase of this work has been concerned with the removal of ice from a substrate such as concrete. The other work on ice cutting has been for possible application to ice breaking ships.

MARINE DYNAMICS AND SHIP LABORATORY

HULL FORM SERIES FOR FAST SURFACE SHIPS

A series of 24 designs has been developed to enable the effects of changing beam, draught, and block and waterplane area coefficients to be determined for hull forms of frigates and for fast patrol vessels. Models have been made of 10 of these designs and are split amidships which enables the effect of changing the bow to be investigated on each of the sterns and vice versa.

Resistance, propulsion and seakeeping tests have been carried out with 10 models from the series, and the results analysed to determine trends of performance with variation in hull form parameters.

An additional model, made by combining the bow of one, with good seakeeping characteristics, with the stern of one with good calm water performance was tested. This proved to have good overall performance and the combined hull was selected as the basis of a practical frigate design.

The project is continuing with the manufacture and testing of 6 more models: two with high beam/draught ratio, two with intermediate length/displacement ratio and two extremely slender designs.

65 FT. EAST COAST FISHING VESSEL

The laboratory is currently investigating whether increase in the beam of small fishing vessels, which has advantages for deck working, leads to any deterioration in seakeeping qualities.

Beam wave rolling experiments have indicated that the use of passive anti-rolling tank stabilization is not altogether suitable for this class of vessel. Conventional bilge keels suffer from ice damage so the possible use and effectiveness of bottom keels is being investigated.

SWATH MANOEUVRING INVESTIGATION

A model of a Small-Waterplane-Area Twin Hull (SWATH) vessel has been constructed in the laboratory. An investigation into the effect of rudder position on its manoeuvrability is to be carried out using this radio-controlled free-running model in the laboratory's large manoeuvring basin.

AIRCRAFT DITCHING CHARACTERISTICS

Federal Airworthiness Regulations require that aircraft intended for operation over large bodies of water, should, in an emergency, be capable of ditching safely on the water's surface. This often entails an extensive model test investigation, as has recently been carried out for Canadair Limited of Montreal on their CL 600 'Challenger' executive jet.

The work involved launching a dynamically scaled model of the aircraft into free flight over water and recording its behaviour, including structural factors, as it landed on the water surface. Ditching tests were carried out for a range of glide approach path angles, flap settings and aircraft altitudes, the object being to determine the optimum approach conditions for safe ditching. The necessary preliminary aerodynamic studies had been previously carried out in the National Aeronautical Establishment's low speed wind tunnel.

RUDDER-FORCED ROLLING

Model studies are being carried out to determine the frequency response in roll and yaw motion to sinusoidal oscillation of the rudder of a self-propelled radio-controlled model of an existing frigate form. The object of this work is twofold:

- (i) Data on the roll and yaw motions induced by rudder movement in calm water may be used to determine the effectiveness of the rudder as a roll stabilizing device in rough water, in addition to its normal role as the primary steering device.
- (ii) By carrying out experiments both with and without the controlled U-tube type roll stabilizer in operation, the effectiveness of this installation, which was previously investigated at zero ship speed, may be determined over a range of ship speeds.

The results of these studies are to be compared with some equivalent full scale data.

LNG CARRIER

The overall economic performance of a proposal to carry LNG from the Arctic to the Eastern Seaboard depends, among many other factors, on having ships which are as low-cost as possible to operate. The hull form must offer a minimum of resistance, and the flow to the propeller be as uniform as possible.

LNG CARRIER (Cont'd)

To achieve these goals, experiments with a model of a proposed LNG ship are being made in the laboratory. The program includes resistance, self-propulsion, wake survey and overload experiments.

ARCTIC CLASS 3 ICEBREAKERS

Scale models have been constructed of an existing Arctic Class 3 Icebreaker which, with the permission of the Canadian Coast Guard, are to be used by the Ice Committee of the International Towing Tank Conference for comparative model tests by the major ice tanks of the world. The Marine Dynamics and Ship Laboratory is conducting an extensive test programme and has also contracted further ice studies to a private Canadian company.

As a follow up to this project, it is planned that further full scale trials will be carried out, which should yield valuable information for correlation purposes. These trials will involve the placing of a number of strain gauges in strategic positions at the ship's bow. The intention is to then establish, among other things, the ice impact loads in conjunction with the ship's power and speed of advance.

RAILWAY LABORATORY

YARD EXPERIMENTS

At the request of the Department of National Defence, impact tests to simulate classification yard conditions were continued for the evaluation of methods of securing heavy military vehicles to a flat car. Results are being analysed and reports are being prepared.

At the request of Bombardier Inc., the torque on the couplers between two LRC (Light-Rapid-Comfortable) coaches was measured while the coach tilting mechanisms were actuated in various failure modes by means of a calibrated strain gauge bridge applied to a coupler shank.

The squeeze frame is being extended to accept cars of 95-foot length.

FIELD EXPERIMENTS

Two bridges have been strain gauged in the Roger's Pass for CP Limited and a report is being prepared.

Assistance was given to Hawker Siddeley Canada Ltd. in acquiring suitable instrumentation to pinpoint the source of damage to shipments of subway cars to U.S. customers.

Records were taken from specially constructed and calibrated load cells to provide a local engineering firm with information concerning the tractive effort of an aircraft towing vehicle.

LABORATORY FACILITIES FOR RAILWAY RESEARCH

Work on the NRC curved track simulator continues in the Manufacturing Technology Centre with the testing of the differential drive gear units and the design of the curve control position levers. The Railway Laboratory has completed most of the control circuit hardware.

In collaboration with the Analysis Laboratory, work continues on a mathematical model of the curved track simulator. In particular, the wheel-roller interaction single point contact phenomenon is being analysed.

The hydraulic actuator system for transverse shaking of railway cars has been completed and will be used early in 1980, in a lateral ride improvement study for VIA's RDC fleet.

GENERAL INSTRUMENTATION

The Laboratory, in co-operation with the Marine Dynamics and Ship Laboratory, has built a micro-processor based ship's motion analyser. An assessment of the analyser on board an ocean ship will be made in the Spring of 1981.

A non-contacting transducer is being developed to measure speed and displacement of ferro-magnetic surfaces by correlating two magnetic noise signals.

An instrumented locomotive wheelset for measuring vertical and lateral rail/wheel forces in service is being developed for Transport Canada Research and Development Centre. Strain gauging, wiring and calibration of the vertical and lateral force bridges on each wheel have been completed. Spin tests and check out of the telemetry has been completed.

Mechanical gauging tools have been built to measure wheel and centre plate wear for CP Rail.

An odometer has been studied for evidence in a fraud investigation for the RCMP.

A very sensitive prototype electrostatic gradient detector has been developed which senses motion of moving objects.

A new approach to communicate at VHF frequencies is under development.

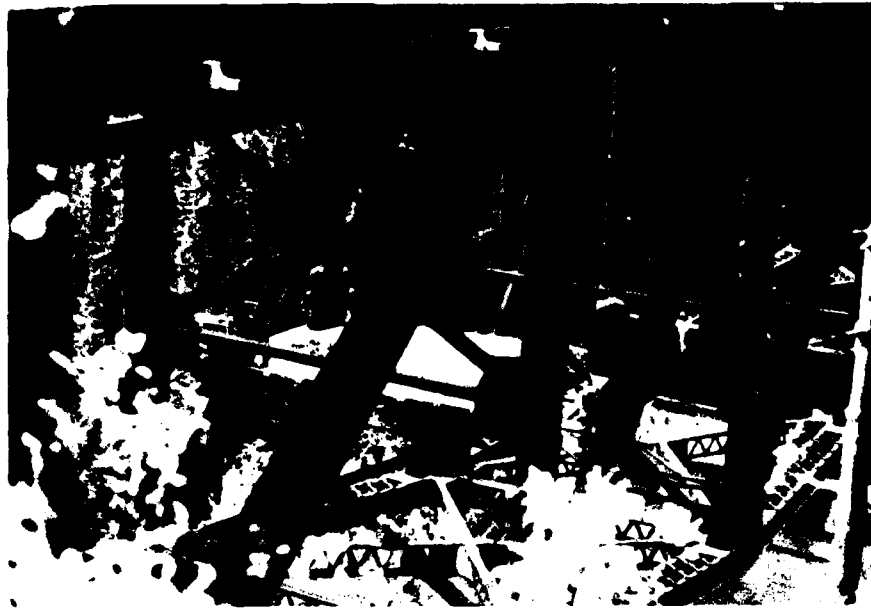

**PREPARING TO FASTEN STRAIN GAUGES TO A
BRIDGE IN THE ROGER'S PASS AREA**



**RECORDINGS OF STRAIN WERE TAKEN WHILE BRIDGE
WAS LOADED WITH A MOVING FREIGHT TRAIN**

**RAILWAY LABORATORY
DIVISION OF MECHANICAL ENGINEERING**

STRUCTURES AND MATERIALS LABORATORY

MOTOR VEHICLE SAFETY

In collaboration with the Road and Motor Vehicle Traffic Safety Branch of Transport Canada the second phase of the studies evaluating headlamp performance is underway. Attention is focussed on the determination of population characteristics of headlamps presently in use. Mean illuminance and glare quadrant values together with data describing the influence of dirt, aim and voltage for a large sample of vehicles are being analyzed within the previously defined system's concept.

VIDEO PHOTOGRAMMETRY SYSTEM FOR REAL TIME THREE-DIMENSIONAL CONTROL

Potential applications for an NRC/NAE 30 Hz Video Photogrammetry System developed for three-dimensional machine control tasks are being examined. The system is based on the principle that knowledge of the centroid data for four targets on a rigid body permits the single camera photogrammetric solution to be solved for each video frame to determine the position and orientation of the body, in real time, for three-dimensional machine control. Initial applications will focus on remote manipulator systems.

METALLIC MATERIALS

Structure-property relationships in aerospace alloys, including cast or wrought nickel and cobalt-base superalloys, high strength titanium and aluminum alloys. Studies on the consolidation and TMT processing of titanium and superalloy compacts by hot isostatic pressing, isothermal and superplastic forging, and extrusion. Studies on the mechanical properties of these materials. The mechanics of cold isostatic compaction of metal powders, and properties of hydrostatically extruded materials. Studies of the oxidation/hot corrosion behaviour of coated and uncoated refractory metals and superalloys.

FRACTOGRAPHY AND FAILURE ANALYSIS

Utilization of transmission and scanning electron microscopes in the study of fracture surfaces, leading to the identification of the micromechanisms of fracture involved in the failure of structural components. From such information it is frequently possible to determine the causes of failures and to suggest remedial action.

FATIGUE OF METALS

Studies of the basic fatigue characteristics of materials under constant and variable amplitude loading; fatigue tests on components to obtain basic design data; fatigue tests on components for validation of design; studies of the statistics of fatigue failures; development of techniques to simulate service fatigue loading.

OPERATIONAL LOADS AND LIFE OF AIRCRAFT STRUCTURES

Instrumentation of aircraft for the measurement of flight loads and accelerations; fatigue life monitoring and analysis of load and acceleration spectra; full-scale fatigue testing of airframes and components. Non-destructive testing and damage tolerance evaluation.

THEORY OF STRUCTURES

Studies of the application of finite element methods to structural problems. Assessment of commercially available computer programs for structural analysis. Calculation of stress-intensity factors for cracked three-dimensional bodies. Damage tolerance analysis.

AEROACOUSTICS

Studies of aerospace-related acoustical problems with special reference to intense noise and its effect on structures. Evaluation of aerospace hardware in intense noise. Studies of jet exhaust noise, wind-tunnel noise, techniques for digital signal processing, enhancement of signals obscured by noise.

FLIGHT IMPACT SIMULATOR

Simulator developed and calibrated to capability of accelerating a 4-lb. mass to a velocity of 1000 ft./sec., and an 8-lb. mass to a velocity of 760 ft./sec. Available to Canadian and Foreign manufacturers for certification of aircraft components and structures. Also used for fundamental studies of the impact process and evaluation of transparencies.

CALIBRATION OF FORCE AND VIBRATION MEASURING DEVICES

Facilities available for the calibration of government, university, and industrial equipment include deadweight force standards up to 100,000 lb., dynamic calibration of vibration pick-ups in the frequency range 10 Hz to 2000 Hz.

NON-METALLIC COMPOSITE MATERIALS

Studies of non-metallic composites including resins, cross-linking compounds, polymerization initiators, selection of matrices and reinforcements, application and fabrication procedures, material properties, and structural design.

POLICE EQUIPMENT STANDARDS

The NRC/CACP Technical Liaison Committee on Police Equipment is a bilateral arrangement for bringing together police and government personnel to review police equipment requirements, equipment performance specifications, and conformance testing procedures. Work of the Committee is expedited by a permanent Secretariat which has a primary responsibility for continuity in the activities of a number of Sections, each dealing with a particular area of expertise, and for co-ordinating work and specialist contributions from various participating Departments and organizations.

UNSTEADY AERODYNAMICS LABORATORY

DYNAMIC STABILITY OF AIRCRAFT

- Measurement of direct, cross and cross-coupling stability derivatives due to roll oscillation.
- Development of an advanced pitch/yaw apparatus.
- Lateral and vertical oscillation experiments.
- Measurements of cross-coupling derivatives at high angles of attack.*
- Development of hydraulic drive systems for high-load oscillatory apparatuses.
- Development and construction of new, fully-digital instrumentation system for dynamic experiments.

ATMOSPHERIC DISTRIBUTION OF POLLUTANTS

- Instrumentation of a small mobile laboratory to measure airborne particulates and of an aircraft to detect atmospheric tracers.
- Commissioning of an instrumented 32-m mobile tower for study of forest meteorology in connection with aerial forest spraying.
- Analysis of N.B. field data on regional-scale airborne drift from a simulated aerial spray and interpretation of results in context of air pollution in N.B. from annual forest spray programme.

TRACE VAPOUR DETECTION

- Development of highly sensitive gas chromatographic techniques for detection of trace quantities of vapours of pesticides, explosives and fluorocarbons.
- Sensitivity evaluation of commercially available explosive detectors.
- Development of stopped-flow and continuous-flow vapour concentrators.
- Determination of vapour pressure of various explosives, pesticides and atmospheric tracers.
- Development and construction of a portable explosives vapour detector.

WORK FOR OUTSIDE ORGANIZATIONS

- Damping and cross-coupling experiments for NASA.
- Feasibility and design studies for NASA.
- Aircraft-security feasibility studies and development projects for Transport Canada.
- Feasibility studies for DSMA, Toronto.
- Experimental assistance to RCMP.
- Field experiments in New Brunswick for Forest Protection Ltd., Fredericton.
- Dynamic experiments for Martin-Marietta.

WESTERN LABORATORY (VANCOUVER)

PRACTICAL FRICTION AND WEAR STUDIES

Laboratory simulations of practical tribological systems to study friction, wear and lubrication behaviour of lubricants and bearing materials in response to specific external requests. For example, experiments using standard and modified domestic furnace fuel pumps to pump both raw and doped methanol are being made to assess the efficacy of previously identified lubricity - improving additives in mitigating wear in pump components.

FUNDAMENTAL STUDIES IN TRIBOLOGY

The preliminary test runs on the rail wheel wear simulator have revealed that some of the apparatus' components contain manufacturing inadequacies and have to be remanufactured. Meanwhile, the collection of rail/wheel wear data and theoretical studies of the subject continues.

LUBRICANTS

Mechanical (load capacity) testing of new, and ferrographic analysis of used lubricating oils has been carried out on behalf of utility and governmental organizations.

BEARINGS

Continuing work on the wick lubricated traction motor support bearings has led to the development of a modified wick system which should prevent water from entering the oil reservoir. This new arrangement is to be tested shortly in the laboratory.

INSTRUMENTATION

Work on the data logging system for the rail-wear simulator has continued with successful testing of the analogue side of the data logging/control system, and the development of methods for storing wear data and wheel profile shapes. Also a floppy disc system has been added to the laboratory mini computer system to facilitate the analysis of rail/wheel wear-rig data.

NUMERICALLY CONTROLLED MACHINING

Technical assistance on this subject is being provided to firms and other institutions in Western Canada which are considering the purchase of numerically controlled machines to improve their production efficiency. Seminars are held to explain the fundamentals of numerical control and programming and information is provided on computer numerical control (CNC) and NC tape preparation/editing systems. Use of computer-assisted programming and punched-tape preparation as a means of reducing manual programming time for items requiring a large number of geometrical statements is demonstrated. Also machine start-up and programming assistance is provided to new users of NC equipment so that they can get quickly into production.

APPROPRIATE TECHNOLOGY

The laboratory has recently been monitoring the progress of this new technological movement towards smaller scale, environmentally and socially appropriate decentralized industrial development. The laboratory has been examining the technical aspects of a number of possible small scale processes, e.g. the development of smaller scale logging equipment for thinning and selective logging.

PUBLICATIONS

National Aeronautical Establishment

LR-599 **APPLICATION OF THE METHOD OF LINES TO THE SOLUTION OF ELLIPTIC PARTIAL DIFFERENTIAL EQUATIONS.**

Jones, D.J., South, J.C., Jr., National Aeronautical Establishment, November 1979.

The method of lines is used in this report for solving one linear, two nonlinear elliptic boundary value problems and a linear eigenvalue problem. An analysis of the stability and convergence is made in the linear cases.

Division of Mechanical Engineering

MK-29 **DYNAMICS OF MULTI-BODY SYSTEMS.**

Mufti, I.H., Division of Mechanical Engineering, November 1979.

The dynamic equations of multi-body systems in the form of open chains are derived by applying the principles of linear and angular momentum to each individual member in the chain. This results in the appearance of constraint forces and torques in the dynamic equations. Using more or less classical approach these unknown forces and torques can be eliminated. Another approach is to approximate these forces by elastic and viscous forces by allowing small violations of the constraints. The well-known elimination procedure leads to a small densely coupled system of equations while the lesser-known procedure of approximating the constraint forces and torques yields a large but less densely coupled system. Both these procedures are first explained in the context of a single rigid body and then applied to a system of rigid bodies in an open chain where each body is coupled directly to at most two neighbours.

LABORATORY TECHNICAL REPORTS

National Aeronautical Establishment

LTR-HA-42 Chan, Y.Y., Seager, S. (summer student)

Computation of Transonic Flow Past Slender Bodies of Revolution. Part I: Equivalent Body, Thickness Case; Part II: Lift Effect.
August 1979.

LTR-ST-1103 Harrison, A.

Use of the NAE Computer Program Libraries to Accomplish an Illuminance Measurement and Analysis Task.
11 October 1979.

LTR-UA-50 Hanff, E.S., Orlik-Rückemann, K.J., Kapoor, K.B., Moulton, B.E., LaBerge, J.G.

New Oscillatory Roll Apparatus and Results on Direct, Cross and Cross-Coupling Subsonic Moment Derivatives for an Aircraft-Like Model.
September 1979.

Division of Mechanical Engineering

LTR-AN-39 Stock, F.T., Gagne, R.E.

A Preprocessor for FORTRAN Programs for the Design of the Variable Data Base.
November 1979.

LABORATORY TECHNICAL REPORTS (Cont'd)

Division of Mechanical Engineering (Cont'd)

- LTR-AN-40 Goodanetz, J.W., Gagne, R.E., Mufti, I.H.
SRMS Joint Control Parameter Sensitivity Study for 32K Payload Using the DME/JDK Hybrid Computer Model.
October 1979.
- LTR-ENG-94 Krishnappa, G.
Cross Spectral Method of Measuring Acoustical Intensity - Correcting Phase Mismatch Error by Calibrating Two
Microphone Systems.
October 1979.
- LTR-LT-105 Stallabrass, J.R., Hearty, P.F.
Further Icing Experiments on an Unheated Non-Rotating Cylinder.
November 1979.
- LTR-LT-106 Lane, J.F.
Traction Motor Suspension Bearing Leakage Tests. Phase III.
October 1979
- LTR-LT-107 Hearty, P.F.
Functional Test on Leigh Ice Detector Serial No. 109.
October 1979.

MISCELLANEOUS PAPERS

- Caiger, B. The Challenges of Digital Flight Data Recorder Readout and Analysis. Presented at ISASI Annual Seminar, Montreal,
September 1979. Published in Proceedings.
- Chan, A.W., Francis, R.L. Some Layout Problems on the Line with Interdistance Constraints and Costs. Operations Research,
Vol. 27, No. 5, Sept.-Oct. 1979, pp. 952-971.
- Fowler, H.S. The Potential of Air Cushion Relief; the Hybrid Vehicle. Paper for the Canadian Society for Terrain Vehicle Systems
Symposium on 'Transportation Problems in Resource Industries', Calgary, October 2 and 3, 1979. To be published in
Proceedings.
- Heggie, W.S., Sandri, R. An Energy-Saving Hydro-Pneumatic Power Plant for the Automobile. ASME Paper 79-WA/DSC-15
presented at the ASME Winter Annual Meeting, 2-7 December 1979.
- Irwin, H.P.A.H., Cooper, K.R., Girard, R. Correction of Distortion Effects Caused by Tubing Systems in Measurements of
Fluctuating Pressures. Journal of Industrial Aerodynamics, Vol. 5, 1979, pp. 93-107.
- Law, C.C.*, Wallace, W., Ashdown, C.P.**, Grey, D.W.*** Sigma-Phase Formation in Conventional and P/M Nickel-Base
Superalloys. Published Metal Science, Vol. 13 (11), 1979, p. 627.
- MacPherson, J.I., Isaac, G.A.****, Schemenauer, R.S.****, Crozier, C.L.****, Strapp, J.W.****, Chisholm, A.J.**** A Physical
Evaluation of Summer Cumulus Cloud Seeding Experiments near Yellowknife and Thunder Bay, Canada. Presented at Seventh
Conference on Inadvertent and Planned Weather Modification, Banff, Alberta, October 8-12, 1979. (Preprint published by
American Meteorological Society, Boston.)

* Pratt & Whitney Aircraft Group, Middletown, Conn.
** Summer Student, NRC/NAE
*** General Electric Co., Schenectady, N.Y.
**** Atmospheric Environment Service

MISCELLANEOUS PAPERS (Cont'd)

- Mufti, I.H. On the Stability of a Single-Species Population Model with Time Lag. *International Journal of Systems Science*, Vol. 10, No. 10, 1979, pp. 1149-1154.
- Osman, M.O.M.*, Sankar, S.*, Dukkupati, R.V. Design Synthesis of a Gyrogrinder Using Direct Search Optimization. *Transactions of the ASME, Journal of Engineering for Industry*, December 1979.
- Osman, M.O.M.*, Bahgat, B.M.*, Dukkupati, R.V. Kinematic Analysis of Spatial Mechanisms Using Train Components. *Transactions of the ASME, Journal of Mechanical Design*, December 1979.
- Rahman, M., Moes, J. Mathematical Modelling of Harbour Oscillation. Division of Mechanical Engineering, Lab Memo HY-203, October 1979.
- Strigner, P.L. Voluntary Test Method and Specification Standards (ASTM) for Petroleum Products from Waste (Used) Oil. NBS Special Publication 556, Measurement and Standards for Recycled Oil-II, September 1979.
- Thamburaj, R.**, Goldak, J.A.***, Wallace, W. Influence of Chemical Compositions on Post-Weld Heat Treatment Cracking in FENE 41. Published SAMPE Quarterly, Vol. 10, No. 4, July 1979.
- Whyte, R.B. Future Availability of Fuels. Proceedings of the Third Symposium on Gas Turbine Operations and Maintenance, NRCC 17869, September 1979.

UNPUBLISHED PAPERS

- Crabbe, R.S. Preliminary Results of 1979 NRC Regional-Scale Field Experiment in N.B. Presented to N.B. Task Force on Long-Distance Drift, UNB, Fredericton, N.B., 6 October 1979.
- Crabbe, R.S. NRC Observations on Plume Spread. Presented to Experts Meeting on Systemization of Plume Sigmas for Canada, AES, Toronto, 4-5 December 1979.
- Crabbe, R.S. 1979 N.B. Field Experiment Results. Presented to Working Group Meeting of CANUSA, Toronto, 31 October 1979.
- Dark, D. NC and the Small Shop. Manitoba Dept. of Industry Seminar "Enterprise Manitoba", November 5-6, 1979.
- Fowler, H.S. Transportation Applications of the Air Cushion Principle. Seminar to the Engineering Department, Carleton University, Ottawa, 8 November 1979.
- Gellie, R.W. Proway - A Standard for Distributed Process Control. Presented at AECL, Chalk River, Ontario, November 27, 1979.
- Immarigeon, J-P. A., Wallace, W. Hot Working Behaviour of Vinertia During Isothermal Forging. Presented at TMS-AIME Fall Meeting, Milwaukee, Wisc., September 1979.
- Irwin, H.P.A.H. The Retractable Fabric Roof for the Montreal Olympic Stadium - Wind Tunnel Investigations. Presented at Construction Colloquium, Civil Engineering Dept., McGill University, October 11, 1979.
- Krishnappa, G. Cross Spectral Method of Measuring Acoustical Intensity. Presented at the 98th Meeting of the Acoustical Society of America in Salt Lake City, Utah, November 1979.
- Laurie-Lean, D.W. Canadian Interest in LTA Activity. Presented at AIAA Lighter than Air Systems Technology Conference, Palo Alto, California, July 1979.
- Liburdi, J.****, Wallace, W. Microstructural and Mechanical Effects of Hip Processing on Superalloys. Presented at TMS-AIME Fall Meeting, Milwaukee, Wisc., September 1979.

* Concordia University, Montreal, Quebec
** Formerly with Dept. of Mechanical Engineering, Carleton University, Ottawa
*** Dept. of Mechanical Engineering, Carleton University, Ottawa
**** Westinghouse Canada Ltd., Hamilton, Ont.

UNPUBLISHED PAPERS (Cont'd)

- Ploeg, J. **New Developments in the Modelling of Waves and Tides.** Lecture presented at Dalhousie University, Halifax, N.S., 22 November 1979.
- Ploeg, J. **The Oceans – A Renewable Energy Resource.** Lecture presented at NRC, Ottawa, 28 November 1979.
- Scott, R.F. **Human Error and Aerospace Structures.** Presented to a Seminar "Human Error and Civil Engineering Structures", held at Chaffey's Locks, The Opinicon, Ontario, October 15-16, 1979.
- Strigner, P.L. **Properties of Canadian Re-refined Base Oils.** Presented at NBS Conference on Measurements and Standards for Recycled Oil/Systems Performance and Durability, Gaithersburg, Md., October 1979.
- Timco, G.W. **The Development of a New Model Ice for Refrigerated Modelling Basins.** Invited lecture given at U.S. Army Cold Regions Research and Engineering Laboratory, Hanover, New Hampshire, U.S.A., November 15, 1979.
- Wardlaw, R.L. **Approaches to the Control of Vibrations of Structures.** Presented to the Montreal Structural Engineers, Canadian Society for Civil Engineers, November 29, 1979.
- Whyte, R.B. **Future Diesel Fuels.** Presented at the Annual Meeting of the Alberta Trucking Association, Calgary, November 1979.

PROPRIETARY PROJECTS DURING 1979

Part of the work of the two Divisions covers proprietary projects, and, for this reason, has not been reported in these Bulletins.

Following is a list of Industrial Organizations, Government Departments and Universities for whom work was done during 1979.

INDUSTRIAL ORGANIZATIONS

Abacus Industrial Equipment Company Ltd., Oakville, Ontario
ACIM Industries, Hull, P.Q.
Aerophoto (1961) Inc., Ste. Foy, P.Q.
A.F. Lehman Associates Inc., Centerport, New York
Albion Machine Works, Kitimat, B.C.
Alcan Canada Products Ltd., Kingston, Ontario
Algoma Steel, Sault Ste. Marie, Ontario
Aluminum Company of Canada, Montreal, P.Q.
Andrew Antenna Company Ltd., Whitby, Ontario
Arctec Canada Ltd., Kanata, Ontario
Argyle Machine Works, Duncan, B.C.
A-TEC Engineered Products Ltd., Peterborough, Ontario
Atlantic Bridge Co. Ltd., Plastics Division, Mahone Bay, Nova Scotia
Aviation Electric Ltd., Montreal, P.Q.

Beaver Asphalt Ltd., Gloucester, Ontario
Beavers Dental Products, Morrisburg, Ontario
Bell Canada, Kitchener, Ontario
Bennett Pollution Controls Ltd., North Vancouver, B.C.
Blue Line Taxi, Ottawa, Ontario
Bombardier Inc., Montreal, P.Q.
BP Canada Ltd., Montreal, P.Q.
BP Refinery (Canada) Ltd., Oakville, Ontario
Brabazon Associates of Canada Ltd., Ottawa, Ontario
British Columbia Hydro & Power Authority, Vancouver, B.C.
British Columbia Institute of Technology, Burnaby, B.C.
Brock McLelland & Assoc. Ltd., Winnipeg, Manitoba
Buckland, Taylor and Associates, West Vancouver, B.C.
Burnett Resource Surveys Ltd., Burnaby, B.C.

CAE Electronics Ltd., Montreal, P.Q.
CAE Machinery Ltd., Vancouver, B.C.
Canada Blower/Canada Pumps Ltd., Kitchener, Ontario
Canadair Ltd., Montreal, P.Q.
Canadian Aircraft Products, Richmond, B.C.
Canadian Airline Pilots Association, Toronto, Ontario
Canadian Car (Pacific), Vancouver, B.C.
Canadian Chromalox Ltd., Toronto, Ontario
Canadian Fram Ltd., Fan Division/Special Products Division, Chatham, Ontario
Canadian General Electric Co., Peterborough, Ontario

Canadian Institute of Guided Ground Transportation, Kingston, Ontario
Canadian International Paper Co. Ltd., Hawkesbury, Ontario
Canadian Thin Films Ltd., Burnaby, B.C.
Canron Ltd., Ville d'Anjou, P.Q.
Centre de recherche industrielle du Québec, Pointe-Claire, P.Q.
Children's Hospital of Eastern Ontario, Ottawa, Ontario
Chrysler Corporation, Windsor, Ontario
Civic Hospital, Ottawa, Ontario
CN Rail, Montreal, P.Q.
Cominco Ltd., Mississauga, Ontario
Cominco Ltd., Trail, B.C.
Composites Development International, Vancouver, B.C.
Comstock International Ltd., Ottawa, Ontario
Conair Aviation Ltd., Abbotsford, B.C.
Corporation of the City of Ottawa, Police Department, Ottawa, Ontario
CP Rail, Montreal, P.Q.
Crorak Products, Beauce, P.Q.
CTF Systems Inc., Port Coquitlam, B.C.

Davis, Eryou and Associates Ltd., Ottawa, Ontario
Deflectaire Corporation, Laval, P.Q.
DeHavilland Aircraft of Canada Ltd., Downsview, Ontario
DEW Engineering & Development Ltd., Ottawa, Ontario
D.G. Instruments Ltd., Kanata, Ontario
Dilworth, Secord, Meagher and Associates Ltd., Toronto, Ontario
Dome Petroleum Co. Ltd., Calgary, Alberta
Dominion Bridge Co. Ltd., Ottawa, Ontario
Dominion Engineering Works Ltd., Montreal, P.Q.
Dow Chemical of Canada Ltd., Sarnia, Ontario

Ebco Industries, Richmond, B.C.
E.F. Barnes Ltd., St. John's, Newfoundland
Ellett Copper & Brass, Port Coquitlam, B.C.

Farinon Electric Co., Montreal, P.Q.
Fathom Oceanology Ltd., Port Credit, Ontario
Ferritronics Ltd., Richmond Hill, Ontario
Firestone Canada Ltd., Joliette, P.Q.
Fluidynamic Devices Ltd., Mississauga, Ontario
Foltz Racing Incorporated, Roseville, Michigan
Ford Motor Company, Oakville, Ontario
Ford Motor Company, Design Centre, Dearborn, Michigan
Forest Protection Ltd., Fredericton, N.B.

GasTOPS Ltd., Ottawa, Ontario
General Behaviour Systems Inc., Toronto, Ontario
General Motors Corporation, Oshawa, Ontario
General Motors Research Laboratories, Warren, Michigan
Guildline Instruments Ltd., Smiths Falls, Ontario
Gulf Canada Products Company, Toronto, Ontario

Haley Industries Ltd., Haley Station, Ontario
Hotel Dieu Hospital, Burns Unit, Kingston, Ontario
Hoverlift Systems Ltd., Calgary, Alberta
Hovey & Associates (1979) Ltd., Ottawa, Ontario
Hydrotechnology Ltd., Ottawa, Ontario

Imperial Oil Enterprises Ltd., Montreal, P.Q.
Imperial Oil Ltd., Edmonton, Alberta
Imperial Oil Ltd., Toronto, Ontario
Industrial High Pressure Systems Inc., Markham, Ontario
Industrial Mill Installations Ltd., Burnaby, B.C.
Innotech Aviation Ltd., Dorval, P.Q.
Institute of Aviation Medicine, Bangalore, India
International Harvester, Fort Wayne, Indiana
International Nickel Company, Sudbury, Ontario
International Nickel Co. Ltd., Copper Cliff, Ontario
International Submarine Engineering Ltd., Port Moody, B.C.
Ironsides Machine Works, Chilliwack, B.C.

J.D. Kendall Consultants Ltd., Mississauga, Ontario
J.T. Donald Consultants Ltd., Scarborough, Ontario

Klein Engineering Ltd., Ottawa, Ontario
Kockums Industries, Surrey, B.C.
Kristiansen Cycle Engines Ltd., Winnipeg, Manitoba

La Société Hotellière du Canadien Pacifique, Toronto, Ontario
Leigh Instruments Ltd., Carleton Place, Ontario
Lockheed Petroleum Services Ltd., New Westminster, B.C.
Lornex Mines Ltd., Logan Lake, B.C.
Lumec Inc., Boisbriand, P.Q.

MacLaren Marex Inc., Dartmouth, Nova Scotia
Magline of Canada Ltd., Renfrew, Ontario
Manitoba Rolling Mills Ltd., Selkirk, Manitoba
Martin-Marietta Corporation, New Orleans, Louisiana
McDonnell-Douglas of Canada, Malton, Ontario
Melville Shipping Ltd./La Compagnie de Navigation Melville Ltée., Montreal, P.Q.
Mental Health Institute, Montreal, P.Q.
Metal Shapes Ltd., Woodstock, Ontario
Microlon (Canada) Ltd., Vancouver, B.C.
Mirolin Industries Ltd., Toronto, Ontario
MLW Bombardier Transportation Products Ltd., La Pocatière, P.Q.
MLW Industries Ltd., Montreal, P.Q.
Montreal Engineering Corp. Ltd., Montreal, P.Q.
Montreal Neurological Institute, Montreal, P.Q.
Morgan Trailers Manufacturing Company, Morgantown, Pennsylvania

New Brunswick Task Force on Long-Distance Drift of Forest Insecticides, Fredericton, N.B.

Nican Corp., Ottawa, Ontario

Nordair Ltd., Dorval, P.Q.

Nortec Air Conditioning Industries Ltd., Ottawa, Ontario

Northern Telecom Canada Ltd., Aylmer, P.Q.

Northern Telecom Ltd., Kingston, Ontario

Northway Survey Corporation Ltd., Toronto, Ontario

Northwest Survey Corporation (Yukon) Ltd., Edmonton, Alberta

Nova Energy Ltd., Halifax, Nova Scotia

Ontario Research Foundation, Mississauga, Ontario

Orhan's Reproduction & Photomapping Ltd., Calgary, Alberta

Ottawa Hydro, Ottawa, Ontario

Pacific Survey Corporation, Vancouver, B.C.

Pasquan Ray, Toronto, Ontario

Petrofina Canada Ltd., Montreal, P.Q.

Philip A. Lapp Ltd., Toronto, Ontario

Philips Electronics Ltd., Scarborough, Ontario

Photosur Inc., Montreal, P.Q.

Pioneer Chain Saw Corporation, Peterborough, Ontario

PPG Industries Inc., Pittsburg, Pa.

Pratt & Whitney Aircraft of Canada Ltd., Longueuil, P.Q.

Production Supply Co. Ltd., Vancouver, B.C.

Quality Products International, Vancouver, B.C.

Quebec Iron and Titanium Corp., Sorel, P.Q.

Rama Stone Quarriers Ltd., Willowdale, Ontario

Relevés Aériens Gar-X Air Survey Limitée/Limited, Laval, P.Q.

Renfrew Electric Co. Ltd., Toronto, Ontario

R.L. Crain Ltd., Ottawa, Ontario

Robert, L., Ottawa, Ontario

Rolls-Royce (Canada) Ltd., Montreal, P.Q.

Royal Aircraft Establishment, Farnborough, England

Royal Alexandra Hospital, Edmonton, Alberta

Royal Insurance Canada, Ottawa, Ontario

Sander Geophysics Ltd., Kanata, Ontario

Saskatchewan Wheat Pool Ltd., Thunder Bay, Ontario

Satellite Truss Ltd., Merrickville, Ontario

SED Systems Ltd., Saskatoon, Sask.

Shawinigan Engineering Co. Ltd., Montreal, P.Q.

Shell Canada Ltd., (Oakville Research Centre), Oakville, Ontario

Shell Canada Ltd., Pointe-aux-Trembles, P.Q.

Sikorsky Aircraft Division, United Technologies, Stratford, Conn.

Société d'Ingénierie Cartier Limitée, Montreal, P.Q.

Society of Automotive Engineers

Space Hovercraft Ltd., Ottawa, Ontario

SPAR Aerospace Ltd., Toronto, Ontario
Spar Technology, Ste. Anne de Bellevue, P.Q.
Standard Aero Ltd., Winnipeg, Manitoba
Steel Co. of Canada, Hamilton, Ontario
Stephens Adamson Ltd., Belleville, Ontario
Superintendence Company (Canada) Ltd., Montreal, P.Q.
Sydney Steel Corp., Sydney, Nova Scotia
Systegral Engineering Ltd., Toronto, Ontario
Systems Technology Incorporated, Hawthorne, California

Teleflex (Canada) Ltd., Vancouver, B.C.
TES Limited, Ottawa, Ontario
Thermax Corporation, Hawkesbury, Ontario
Toronto Harbour Commissioners, Toronto, Ontario
Travelways Inc., Ottawa, Ontario
Trow Engineering Group Ltd., Rexdale, Ontario
TUL Safety Equipment Ltd., Hawkesbury, Ontario

Union Carbide Canada Ltd., Toronto, Ontario

Vancouver Gear Works, Richmond, B.C.
Van Dusen Commercial Development Corp., Ottawa, Ontario
Van Dyk, R., Dunrobin, Ontario
Varian Associates of Canada Ltd., Georgetown, Ontario
VIA Rail Canada Inc., Montreal, P.Q.
Viking Helicopters Ltd., Carleton Place, Ontario

Wagner Engineering Ltd., North Vancouver, B.C.
Walden North Enterprises, Lillooet, B.C.
Westeel-Roscoe Ltd., Mississauga, Ontario
Western Packaging Systems, Richmond, B.C.
Western Research and Development, Calgary, Alberta
Westinghouse Canada Ltd., Hamilton, Ontario
Worthington (Canada) Ltd., Brantford, Ontario

GOVERNMENT DEPARTMENTS AND AGENCIES

Agriculture Canada, Ottawa, Ontario
Air Canada, Montreal, P.Q.
Alberta Department of Consumer and Corporate Affairs, Edmonton, Alberta
Alberta Transportation, Alberta Provincial Government, Edmonton, Alberta
Atomic Energy of Canada Ltd., Chalk River, Ontario

British Columbia Hydro and Power Authority

Canada Safety Council, Ottawa
Canadian Government Specifications Board, Hull, P.Q.
Canadian National Ski Team

Churchill Research Centre, Government of Manitoba, Churchill, Manitoba
City of Ottawa, Ottawa, Ontario
City of Vanier Police Dept., Vanier, Ontario
Commission Scolaire Haute-Gatineau, Maniwaki, P.Q.
Communications Research Canada, Ottawa, Ontario
Consumer & Corporate Affairs Canada (Consumer Fraud Protection), Hull, P.Q.
Consumer & Corporate Affairs Canada (Consumer Fraud Protection), Toronto, Ontario
Consumer & Corporate Affairs Canada (Consumer Fraud Protection), Vancouver, B.C.
Consumer & Corporate Affairs Canada (Marketing Practices), Hull, P.Q.

Defence Research Establishment Atlantic, Dartmouth, Nova Scotia
Defence Research Establishment Ottawa, Ottawa, Ontario
Defence Research Establishment Pacific, Victoria, B.C.
Department of Lands and Forests, Quebec City, P.Q.
Department of National Defence, Directorate of Aeronautical Engineering and Simulators, Ottawa, Ontario
Department of National Defence, Land Engineering Test Establishment, Orleans, Ontario
Department of National Defence, Maritime Equipment Engineering, Ottawa, Ontario
Department of National Defence, National Defence Headquarters, Ottawa, Ontario
Department of National Defence, Quality Engineering Test Establishment, Hull, P.Q.
Department of Public Works, Ottawa, Ontario
Department of Roads and Traffic, The Municipality of Metropolitan Toronto, Traffic Control Centre, Toronto, Ontario

Energy, Mines and Resources Canada, Ottawa, Ontario
Environment Canada, Downsview, Ontario
Environment Canada, Ottawa, Ontario
Environment Canada, Atmospheric Environment Service, Downsview, Ontario
Environment Canada, Emission Testing Laboratory, Ottawa, Ontario
Environment Canada, Environmental Protection Service, Hull, P.Q.
Environment Canada, Forest Management Institute, Ottawa, Ontario
Environment Canada, Forest Pest Management Institute, Sault Ste. Marie, Ontario
Environment Canada, Geological Survey of Canada, Ottawa, Ontario
Environment Canada, Glaciology Division, Ottawa, Ontario

Federal Aviation Administration, Washington, D.C.
Fisheries & Environment Canada, Fisheries & Marine Service, Ottawa, Ontario

Industry, Trade & Commerce, Ottawa, Ontario
Institut de recherches de l'Hydro-Québec, Varennes, P.Q.
Institute of Man and Resources, Prince Edward Island

Laurentian Forest Research Center, Ste. Foy, P.Q.

Manitoba Dept. of Industry, Manitoba
Ministère de la Justice, Maniwaki, P.Q.
Ministry of Natural Resources, Ontario, Sault Ste. Marie, Ontario
Ministry of Natural Resources, Toronto, Ontario
Ministry of Transport, Coast Guard Waterways Development, Ottawa, Ontario
Ministry of Transportation & Communications Ontario, Engineering Materials Office, Downsview, Ontario

NASA Ames Research Center, Moffett Field, California
National Capital Commission, Ottawa, Ontario
National Harbours Board, Port of Montreal, P.Q.
National Research Council Canada, Committee on Aviation Security, Ottawa, Ontario
Newfoundland and Labrador Hydro

Olympic Installation Boards, Montreal, P.Q.
Ontario Department of Environment, Toronto, Ontario
Ontario Hydro, Toronto, Ontario

Petro Canada, Calgary, Alberta
Public Works Canada, Ottawa, Ontario
Public Works Canada, St. John, New Brunswick
Public Works Canada, Toronto, Ontario

Quebec Government, Hydro-Quebec, Montreal, P.Q.

Research Council of Saskatchewan, Saskatoon, Sask.
Royal Canadian Mounted Police, Ottawa, Ontario
Royal Canadian Mounted Police, Sault Ste. Marie, Ontario

Sandia Corporation, Albuquerque, New Mexico, U.S.A.
Saskatchewan Power Corporation
St. Lawrence Seaway Authority, St. Lambert, P.Q.

Transport Canada, Ottawa, Ontario
Transport Canada, Air Traffic Control Simulation Centre, Ottawa, Ontario
Transport Canada, ASF, Ottawa, Ontario
Transport Canada, Canadian Coast Guard, ACV Division, Ottawa, Ontario
Transport Canada, Research & Development Centre, Montreal, P.Q.
Transport Canada, Road & Motor Vehicle Traffic Safety, Ottawa, Ontario
Transport Canada, Telecommunications and Electronics, Air, Resolute Bay, N.W.T.

U.S. Department of Transport, Cambridge, Mass.

UNIVERSITIES

California Institute of Technology, Pasadena, California
Carleton University, Mechanical Engineering Dept., Ottawa, Ontario

Imperial College of Science and Technology, London, England

McGill University, Montreal, P.Q.
McGill University, Department of Mechanical Engineering, Montreal, P.Q.

Queen's University, Kingston, Ontario
Queen's University, Biomedical Engineering Unit, Kingston, Ontario

University of British Columbia, Mechanical Engineering Dept., Vancouver, B.C.

University of Calgary, Dept. of Mechanical Engineering, Calgary, Alberta

University of Guelph, Department of Family Studies, Guelph, Ontario

University of Maryland, College Park, Maryland

University of Sherbrooke, Department of Mechanical Engineering, Sherbrooke, P.Q.

University of Toronto, Department of Biology, Toronto, Ontario

University of Washington, Seattle, Washington, D.C.

FILM
5-