

MICROCOPY RESOLUTION TEST CHART
NATIONAL BUREAU OF STANDARDS-1963-A

12 LEVEL II

APPLICATION OF THE FOSTER CHANNEL BLOCK MONITOR (FCBM)
TO AIR/GROUND COMMUNICATIONS

by

David G. Herold

Avionics Engineering Center
Department of Electrical Engineering
Ohio University
Athens, Ohio 45701

ADA 082880



DECEMBER 1979

FINAL REPORT

Document is available to the public through the
National Technical Information Service
Springfield, Virginia 22161

Prepared for

FEDERAL AVIATION ADMINISTRATION
Airway Facilities Sector
Washington, D.C. 20591

DTIC ELECTE
S APR 9 1980 D
B

DDC FILE COPY

80 4 . 7 181

1. Report No. FAA-R-6600.1		2. Government Accession No.		3. Recipient's Catalog No.	
4. Title and Subtitle APPLICATION OF THE FOSTER CHANNEL BLOCK MONITOR (FCBM) TO AIR/GROUND COMMUNICATIONS				5. Report Date December 1979	
7. Author(s) David G. Herold				6. Performing Organization Code 12-11	
9. Performing Organization Name and Address Avionics Engineering Center Department of Electrical Engineering Ohio University Athens, Ohio 45701				8. Performing Organization Report No. EER-42-1	
12. Sponsoring Agency Name and Address Federal Aviation Administration Airway Facilities Service Washington, D.C. 20591				10. Work Unit No.	
				11. Contract or Grant No. DOT-FA79WA-4318	
				13. Type of Report and Period Covered Final Report - June 1979 - December 1979	
15. Supplementary Notes				14. Sponsoring Agency Code	
16. Abstract <p>The Foster Channel Block Monitor (FCBM) is a device which monitors the interference level of a communications channel while the operator is transmitting. The result of this capability is to reduce co-channel transmissions which block each other. This paper describes an implementation of the FCBM concept in retro-fitting standard FAA ground-to-air communications equipment. No function of the communications equipment is lost due to the addition of the FCBM capability. The sensitivity of the receiver remains unchanged. This paper also describes the in-band and out-of-band interference of the unit and shows that these are below that required by the FCC Rules and Regulations. The unit performed accurately in bench tests. The operator is alerted to the presence of an interfering signal and given an indication of the level of the signal by lights on the control panel.</p>					
17. Key Words Communications Channel Block Interference Air-to-Ground VHF ATC Tower Modulation			18. Distribution Statement This document is available to the U.S. public through the National Technical Information Service, Springfield, Virginia 22161.		
19. Security Classif. (of this report) Unclassified		20. Security Classif. (of this page) Unclassified		21. No. of Pages 42	22. Price

261450

METRIC CONVERSION FACTORS

Approximate Conversions to Metric Measures

Symbol	When You Know	Multiply by	To Find	Symbol
LENGTH				
in	inches	2.5	centimeters	cm
ft	feet	30	centimeters	cm
yd	yards	0.9	meters	m
mi	miles	1.6	kilometers	km
AREA				
sq ft	square inches	6.5	square centimeters	cm ²
sq ft	square feet	0.09	square meters	m ²
sq yd	square yards	0.8	square meters	m ²
sq mi	square miles	2.6	square kilometers	km ²
acres	acres	0.4	hectares	ha
MASS (weight)				
oz	ounces	28	grams	g
lb	pounds	0.45	kilograms	kg
short tons	short tons	0.9	tonnes	t
VOLUME				
cup	cup	0.24	liters	l
fl oz	fluid ounces	0.03	liters	l
qt	quarts	0.95	liters	l
gal	gallons	3.8	liters	l
cu ft	cubic feet	0.03	cubic meters	m ³
cu yd	cubic yards	0.76	cubic meters	m ³

TEMPERATURE (exact)

°F	Fahrenheit temperature	5/9 (after subtracting 32)	Celsius temperature	°C
----	------------------------	----------------------------	---------------------	----

Approximate Conversions from Metric Measures

Symbol	When You Know	Multiply by	To Find	Symbol
LENGTH				
mm	millimeters	0.04	inches	in
cm	centimeters	0.4	inches	in
m	meters	3.3	feet	ft
km	kilometers	0.6	miles	mi
AREA				
cm ²	square centimeters	0.16	square inches	sq in
m ²	square meters	1.2	square yards	sq yd
km ²	square kilometers	0.4	square miles	sq mi
ha	hectares (10,000 m ²)	2.5	acres	acres
MASS (weight)				
g	grams	0.035	ounces	oz
kg	kilograms	2.2	pounds	lb
t	tonnes (1000 kg)	1.1	short tons	short tons
VOLUME				
ml	milliliters	0.03	fluid ounces	fl oz
l	liters	1.06	quarts	qt
l	liters	0.26	gallons	gal
m ³	cubic meters	35	cubic feet	cu ft
m ³	cubic meters	1.3	cubic yards	cu yd
TEMPERATURE (exact)				
°C	Celsius temperature	9/5 (then add 32)	Fahrenheit temperature	°F



* 1 in = 2.54 (exact). For other exact conversions and more data on labels, see NBS 113c, Publ. 236, Units of Weight and Measure, Price \$2.25, SO Catalog No. C1310-236.

TABLE OF CONTENTS

	<u>PAGE</u>
List of Figures	iv
List of Tables	v
I. SUMMARY, CONCLUSIONS, AND RECOMMENDATIONS	1
II. INTRODUCTION	2
III. FCBM - SYSTEM DESCRIPTION	2
A. Statement of the Problem	2
B. Desired Solution	3
C. The Foster Channel Block Monitor	3
IV. EQUIPMENT MODIFICATION	11
A. General	11
B. Modification of Transmitter and Receiver	11
V. INVESTIGATORS AND ACKNOWLEDGEMENTS	24
VI. REFERENCES	29
VII. APPENDICES	30
A. Out-of-Band Frequency Response Program	30
B. In-Band Frequency Response Program	32
C. Graph of Signal Strength Vs. Distance	37
D. Circuit Board Photographs	39

ACCESSION for	
NTM	White Section <input checked="" type="checkbox"/>
BDC	Buff Section <input type="checkbox"/>
UNANNOUNCED	<input type="checkbox"/>
JUSTIFICATION _____	
BY _____	
DISTRIBUTION/AVAILABILITY CODES	
Dist. AVAIL. and/or SPECIAL	
A	

LIST OF FIGURES

	<u>PAGE</u>
Figure 1. FCBM System Block Diagram.	5
Figure 2. Square Wave Switching Signal.	7
Figure 3. Frequency Domain Plot of the Switched Signal Spectrum.	7
Figure 4. Trapezoidal Wave Switching Waveform	9
Figure 5. Transmitter Switching Waveforms.	9
Figure 6. Audio Switching Waveform in the Frequency Domain.	10
Figure 7. Receiver and Transmitter.	12
Figure 8. Cab Control Unit.	13
Figure 9. Receiving and Transmitting Antennas.	14
Figure 10. Monitor Receiver.	15
Figure 11. FCBM Transmitter Control Board.	16
Figure 12a. Transmitter Modifications (Board A6).	17
Figure 12b. Transmitter Modifications (Board A2).	18
Figure 13. Receiver Modifications (Board A3).	19
Figure 14. Receiver Board.	20
Figure 15. FCBM Phoneme Interval Detector.	22
Figure 16. FCBM Transmitter Switching Delay Generator.	23
Figure 17. Sequencer and Control Board.	25
Figure 18. FCBM Display Board.	26
Figure 19a. Cabling Diagram.	27
Figure 19b. Cabling Diagram.	28
Figure C-1. Graph of Signal Strength Vs. Distance.	38

LIST OF FIGURES (Cont.)

	<u>PAGE</u>
Figure D-1. Transmitter Board Mounted in the Transmitter.	40
Figure D-2. Receiver Board.	41
Figure D-3. Control and Sequencer, PID and Delay Generator Circuitry.	42

LIST OF TABLES

Table 1. Adjacent Channel Interference for the Square Wave Switching Waveform.	6
Table 2. Adjacent Channel Interference for Trapezoidal Wave Switching Waveform.	8
Table 3. In-Band Distortion.	10
Table 4. GFE Equipment Received by Ohio University.	21

I. SUMMARY, CONCLUSIONS, AND RECOMMENDATIONS

The Foster Channel Block Monitor (FCBM) consists of an electronic switching unit and an AGC monitor/display unit. These two main system elements, when used to switch the carrier of a transmitter on and off using a specific switching waveform and to monitor the behavior of the receiver AGC voltage during the transmitter off-time, allow detection of interfering on-channel signals. Further, the interfering signal can be characterized by its signal strength in three discrete ranges. Presence of the interference can be displayed to the system operator who can then take appropriate action to minimize the effect of the potential channel blockage on information transfer.

Through careful selection of the transmitter switching waveform, effects of the switched-carrier operation on message intelligibility and on interchannel interference due to switching harmonics can be minimized and kept within FCC requirements for air/ground communications systems. The quality of reception in the receiver was not affected by the modifications.

Specific conclusions based on this work are:

1. It is possible to retrofit standard FAA ground equipment to implement the FCBM function.
2. FCBM detects interference of as little as $10 \mu\text{v/M}$, and displays the output on front panel indicator lights. A series of lights can be used to indicate different signal levels, if desired.
3. The THD of the transmitted spectrum is 0.66%.
4. The retrofit of typical (AN/GRR 23 and T-1108) ground transmitter/receiver equipment is estimated to cost \$250 (1979) in parts and \$500 (1979) in labor.
5. No receiver, transmitter or tower cab control functions are lost by the retrofit.
6. Retrofit of cab control equipment is estimated to cost \$100 (1979) in parts and \$200 (1979) in labor.
7. The most effective indication of blockage must be determined through use.

The following recommendations are made:

1. Equip a typical airborne Tx/Rx unit for two-ended demonstration capability and for evaluation of displays appropriate for cockpit use.
2. Carry out system demonstrations at various air traffic facilities for comments and suggestions.

3. Carry out a hard retrofit of a TR set for installation in parallel with commissioned equipment at an FAA site; perhaps an FSS, for on-line evaluation by operational personnel.
4. Invite tests by pilots using the airborne unit.

II. INTRODUCTION

This Final Report describes the work accomplished by the Avionics Engineering Center, Ohio University, in support of Contract FA79WA-4318, "Application of the Foster Channel Block Monitor (FCBM) to Air/Ground Communications". The purpose of this program is to demonstrate the operation of the FCBM retrofit on contemporary ground transmitter/receiver equipment.

Theory of operation is presented, together with documentation of the required modifications to existing voice communication equipment. Results of tests on the modified transmitter and receiver are included, illustrating the minimal effect of FCBM operation on intelligibility and interchannel interference. Photo documentation of the transportable FCBM demonstration pallets is presented; these pallets and their antenna masts are designed for simulation of the ATC tower cab communications installation at various demonstration sites.

III. FCBM - SYSTEM DESCRIPTION

A. Statement of the Problem. The potential for interruption of information transfer in radio communications exists whenever two or more persons have transmitting capability on a single frequency. The potential is definitely present, therefore, on VHF air/ground communications channels used in the air traffic system and the various aviation advisory channels. Interruption or blockage of information may occur for several reasons.

1. Insufficient signal strength at the receiver to allow successful detection of the information. This problem occurs generally because of excessive distance between transmitter and receiver, lack of line-of-sight at VHF, or because of receiver insensitivity. In general, air/ground communications outlets on the ground are sited appropriately for their intended purpose, and pilots are assigned frequencies and altitudes which are serviced by ground stations known to provide adequate signal strength. Modern airborne and ground receiving equipment is generally very sensitive.

Insufficient signal strength, then, should rarely be the cause for unsuccessful communications in the air/ground system.

2. Presence of interference at or near the frequency being used. As has been noted, both ground and airborne receivers used in the air/ground system are sensitive to signal strengths of 3 microvolts or less. The presence of relatively small amounts of

on-frequency interference may garble the desired message by causing heterodyne noise or audio distortion. At worst, the co-channel interference may capture the receiver, blocking the desired message altogether.

This on-frequency or 'in-band' interference can result from the presence of harmonics or intermodulation products of transmitters operating at other frequencies. This harmonic interference is generally quite low-level in nature, and is regulated by FCC regulations on transmitter performance. Some problems are noted in locations where aircraft operate near very high-power commercial FM stations, but the difficulty is not general in nature.

The primary cause of information loss in the air/ground communications system is co-channel interference; defined as two or more transmitters operating simultaneously at the same (within 1-2 KHz) frequency. This interference causes blockage or garble of desired messages, even with relatively low levels of interfering signal, since the receiver cannot differentiate among the transmitted signals on the basis of frequency.

Channel blockage occurs under several scenarios:

1. A pilot listens on a channel for a few seconds, and then keys his microphone to call an FSS, unaware that his receiver squelch is 'hiding' an ongoing transmission from another aircraft. As a result, the FSS may not hear the original message nor the interfering pilot's message.

2. At an airport, the pilot of a taxiing aircraft and the ground controller chance to key their microphones simultaneously to send messages. As a result, a second aircraft fails to hear the ground controller's message and hears instead a heterodyne squeal. This scenario is borne out in investigations of the Tenerife accident in 1977 [1] and the San Diego accident in 1978 [2].

3. An approach controller gives a vector to an aircraft in a terminal area, but due to a simultaneous transmission by a second aircraft, the vector clearance is not received. The controller has to repeat the clearance. In a busy terminal environment, the controller may not expect a 'roger' to every transmission, and may have to repeat the clearance after determining from radar that the turn was not made.

B. Desired Solution. In all these scenarios, at the very least, the offending transmitter should be given an indication that interference is present on the channel and the option should be present to prevent a transmitter from operating until the channel is clear. Additionally, information about the strength of the existing signal should be displayed for the information of the transmitter operator.

C. The Foster Channel Block Monitor. The Foster Channel Block Monitor (FCBM) is a device which monitors the interference level of a communications channel during transmissions. The method used to implement this function is to reduce periodically the transmitted carrier to zero for a short time and during this time sample the receiver AGC signal to determine the level of co-channel signal.

A block diagram of the system is shown in Figure 1. The system controller and sequencer receives a pulse from the sample timing circuit. The controller then ramps the transmitter power toward zero. When the power reaches zero output, the receiver AGC is unclamped and allowed to float toward its natural value, the value corresponding to the level of the received signal. After a sufficient settling time, the receiver AGC is compared to three preset levels. The status of these three comparisons is stored and displayed as the level of the interfering signal. The three levels are controlled individually and would be set to indicate the following situations. The first light would indicate an aircraft within a range of 50 miles. The second would indicate 5 to 10 miles and the third would indicate an airplane 0 to 2 miles away. The exact distance at which an aircraft radio would trigger a particular light would vary according to atmospheric conditions, terrain and transmitter power.

The "phoneme interval" is a period of silence which occurs in all human speech. The phoneme interval detector produces a pulse whenever the modulation voltage has been below a preset threshold voltage for 7 msec. According to research done on phoneme intervals [3], if a 7 msec silence occurs in the human speech pattern, the silence will continue for at least 8 msec more. Consequently, the phoneme interval detector allows the sampling to occur at a time when no information is being transferred.

The sample pulse timing circuit takes the input from the phoneme interval detector and generates the timing pulses which are not closer than 0.5 sec in time nor further than 1.5 sec.

The FCBM requires that the transmitted carrier be reduced periodically to zero output so that the received signal may be sampled. By switching the carrier off, undesired sidebands are produced, the magnitudes of which depend upon the waveform used to switch the carrier. The analysis which follows presents the reasons for choosing the final switching waveform and gives the bounds on the levels of undesired sidebands.

The spectral analysis was approached using both analytical methods and computer models. The analysis was separated into in-band and out-of-band components, and both are presented below.

The response of the transmitter with a switched output can be obtained by representing the transmitter output by the unswitched output multiplied by a switching function.

$$f_s(t) = f(t)S(t) \quad (1)$$

where $f_s(t)$ is the switched transmitter output
 $f(t)$ is the unswitched transmitter output
 $S(t)$ is the switching function.

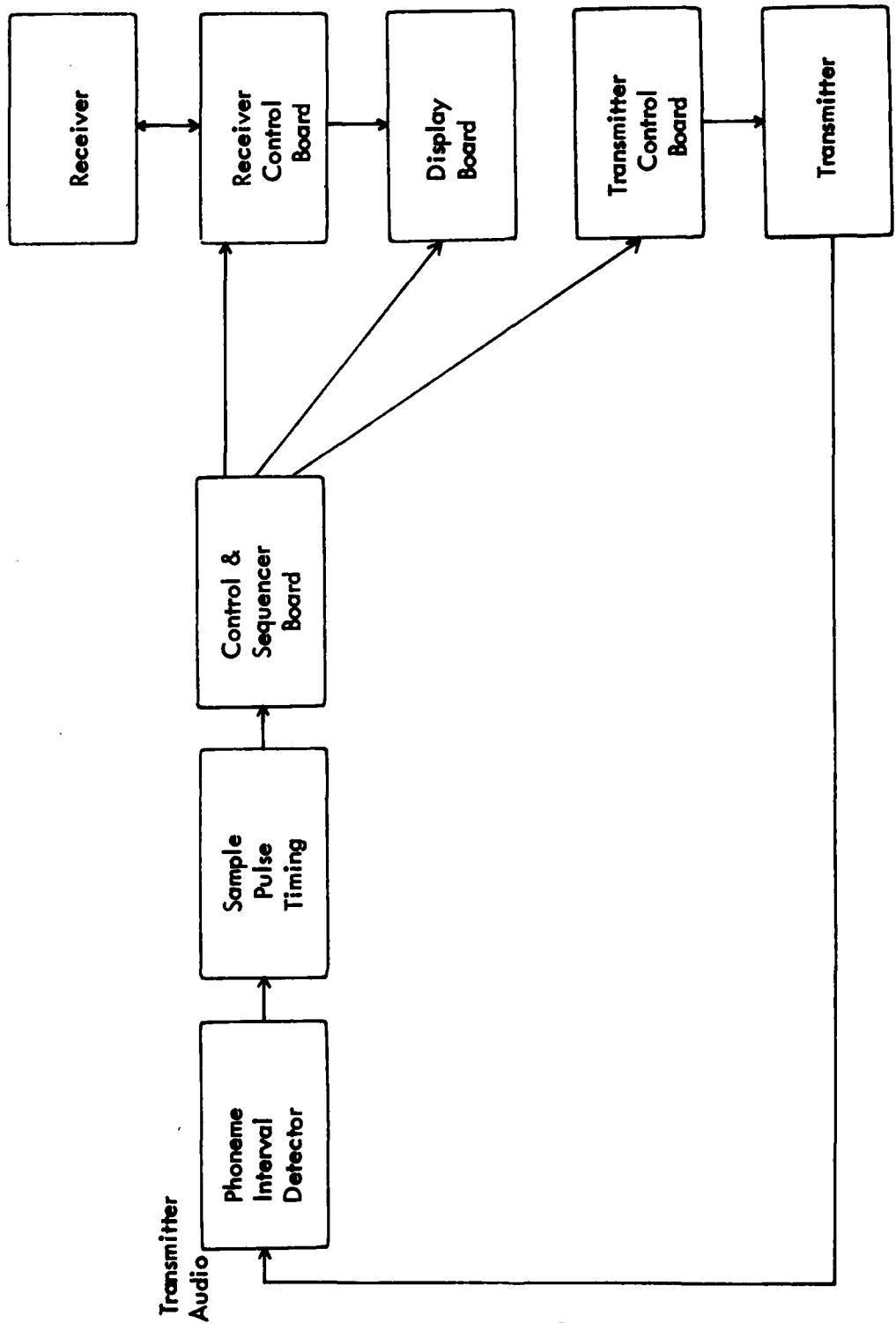

Figure 1. FCBM System Block Diagram.

The square wave switching waveform $S(t)$ is shown in Figure 2 with period T and off-time a . By expanding the switching function in its Fourier series, the sampled signal can be written in the form:

$$f_s(t) = -\frac{a}{T} f(t) \left(1 + 2 \sum_{n=1}^{\infty} \frac{\sin \frac{n\pi a}{T}}{\frac{n\pi a}{T}} \cos \frac{2\pi n t}{T} \right) \quad (2)$$

Taking the Fourier transform of the sampled signal yields [4]:

$$F_s(\omega) = \frac{a}{T} F(\omega) + \frac{a}{T} \sum_{\substack{n=-\infty \\ n \neq 0}}^{\infty} \frac{\sin \frac{n\pi a}{T}}{\frac{n\pi a}{T}} F(\omega - n\omega_s) \quad (3)$$

where $\omega_s = \frac{2\pi}{T}$.

The resulting spectrum is the sum of the spectra of a series of signals each having the same shape in the frequency domain as the unswitched signal, but shifted in frequency by a multiple of the switching frequency as shown in Figure 3.

In order to calculate the out-of-band signals generated by switching the transmitter carrier, a computer program was written to sum the contributions of each of the signals from Equation (3). The program listing is included in Appendix A. The program sums the square of the voltage responses calculated from Equation (3) over a range of frequencies. Table 1 summarizes the results of this program giving adjacent-channel responses compared to the in-band carrier level.

Frequency Range	Normalized Power	
	watts	dB
12.5 KHz to 37.5 KHz (1st adjacent channel)	0.28×10^{-5}	-56
37.5 KHz to 62.5 KHz (2nd adjacent channel)	0.55×10^{-6}	-63
62.5 KHz to 87.5 KHz (3rd adjacent channel)	0.24×10^{-6}	-66

Table 1. Adjacent Channel Interference for the Square Wave Switching Waveform.

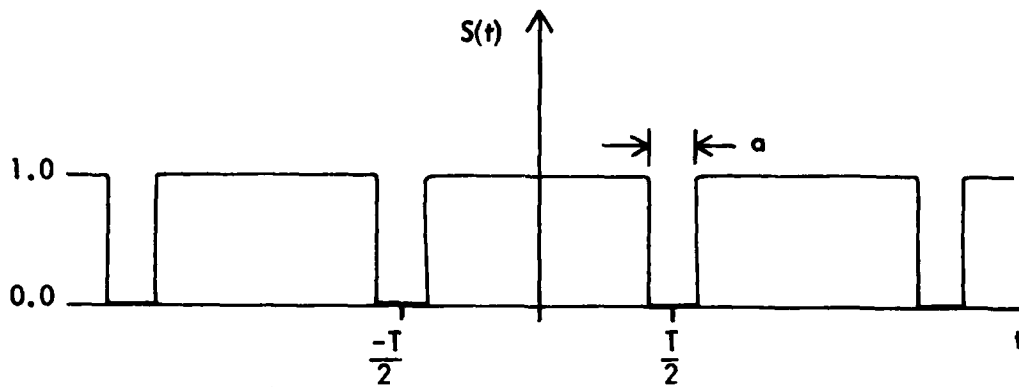

Figure 2. Square Wave Switching Signal.

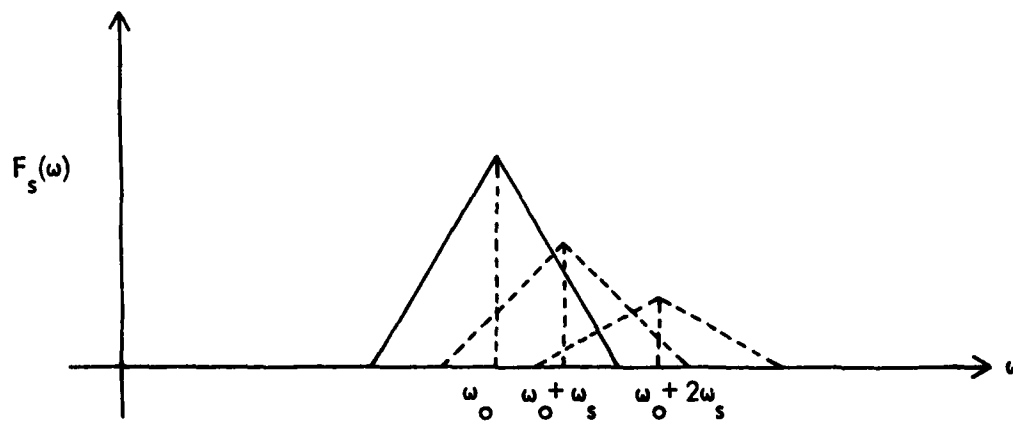

Figure 3. Frequency Domain Plot of the Switched Signal Spectrum.

The Fourier series for the case of the trapezoidal switching waveform (Figure 4) can be determined by a development parallel to that presented for the square wave switching waveform. The Fourier series for the trapezoidal waveform is:

$$F_s(\omega) = \frac{T_1 + T_2}{T} F(\omega) + \frac{1}{T} \left(\frac{2}{T_2 - T_1} \sum_{\substack{n=-\infty \\ n \neq 0}}^{\infty} \frac{\cos n \omega_s T_1 - \cos n \omega_s T_2}{(n \omega_s)^2} \right) F(\omega - n \omega_s) \quad (4)$$

Table 2 presents the power level of interfering harmonics in the 3 adjacent channels. A comparison of Tables 1 and 2 shows that the interference generated by the trapezoidal switching waveform is at least 46 dB down from that produced by the square wave switching waveform in any 25 KHz bandwidth. The adjacent-channel interference levels conform to FCC requirements as set forth in Volume 5, Part 87.71.

Frequency Range	Normalized Power	
	watts	dB
12.5 to 37.5 KHz (1st adjacent channel)	$.68 \times 10^{-10}$	-102
37.5 KHz to 62.5 KHz (2nd adjacent channel)	$.20 \times 10^{-11}$	-117
62.5 KHz to 87.5 KHz (3rd adjacent channel)	$.36 \times 10^{-12}$	-124

Table 2. Adjacent Channel Interference for Trapezoidal Wave Switching Waveform.

To obtain the in-band distortion, a program was written which calculates the Fourier transform of the transmitted signal (Appendix B). Three different switching waveforms were modeled with this program. The waveforms are shown in Figure 5. Table 3 summarizes the total harmonic distortion caused by these waveforms. The amplitude of the harmonics drops off with a $\sin x/x$ factor so higher-frequency components contribute less distortion than the lower frequency components. Ninety percent of the THD is contained within 100 Hz of the unswitched spectrum. This indicates that significant improvement can be obtained by filtering the audio signal at the receiver to remove the low-frequency components without interfering with the information content of the signal.

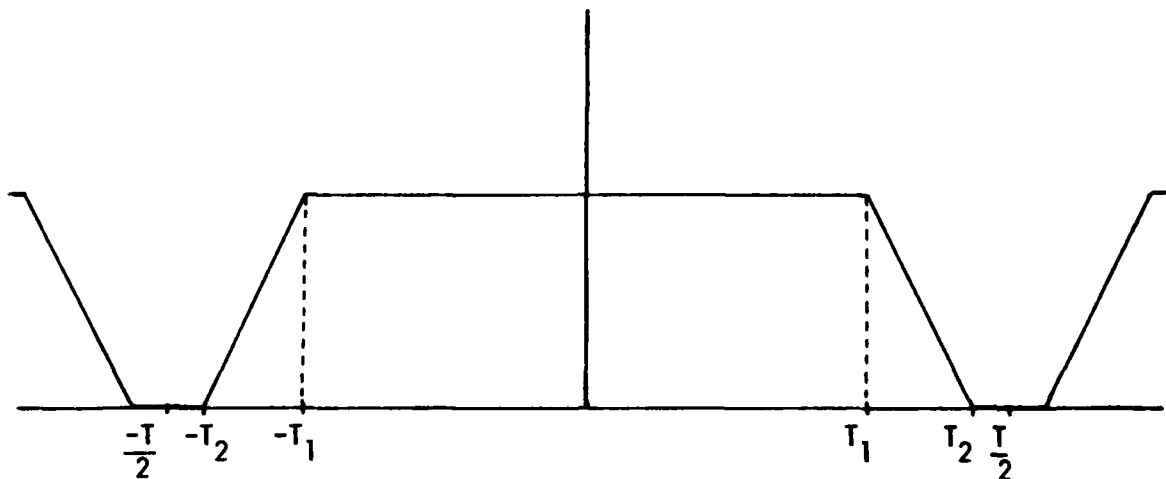

Figure 4. Trapezoidal Wave Switching Waveform.

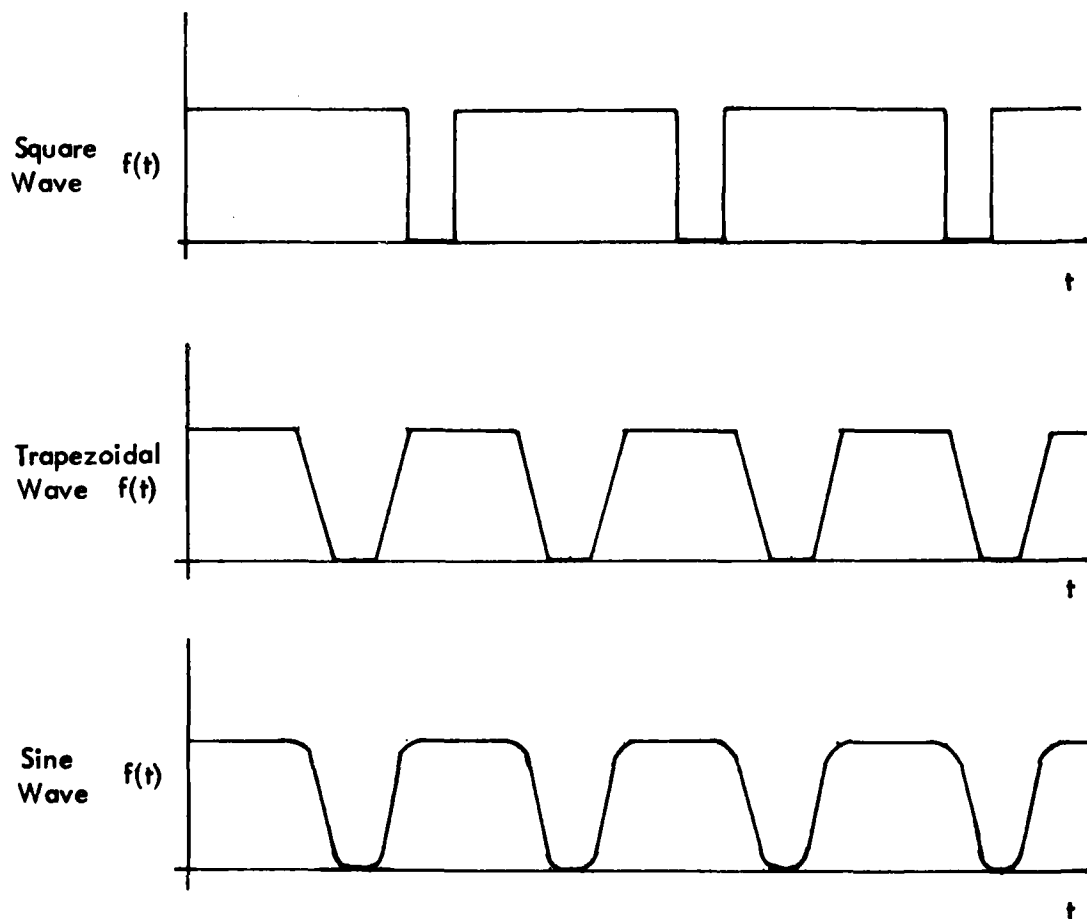

Figure 5. Transmitter Switching Waveforms.

Switching Waveform	Total Harmonic Distortion (%)
Square wave	0.99
Trapezoidal wave	0.66
Sine wave	0.60

Table 3. In-Band Distortion.

Although the sine wave switching waveform produced lower THD than the trapezoidal waveform, the trapezoidal waveform had smaller components at the higher frequencies and thus reduced the adjacent channel interference. Because the in-band distortion of both waveforms was found to be acceptable, the trapezoidal waveform was chosen for use in the final implementation.

Periodic switching of the transmitted carrier causes a spreading of the audio spectrum that is equivalent to mixing the audio signal with the signal in Figure 6. The result is an audible click that can be heard in the received signal when receiving a high-level RF signal. Flight tests indicate that the click is only noticeable within several hundred yards of the transmitting antenna. After take-off the signal was faintly detectable to a distance of about 1 mile where it was lost in the noise. The click can be reduced considerably by switching the transmitted signal during periods of no modulation in the transmission. At these times the frequency spectrum of the click consists only of frequencies below 100 Hz. The click is then attenuated by the aircraft receiver and speaker. Although reception of the transmitted click was very noticeable in the immediate vicinity of the transmitter, at no time did the click impair the reception of the transmitted information.

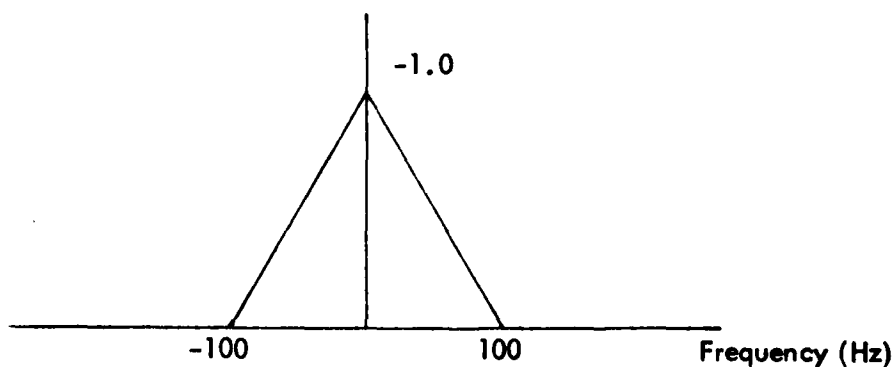

Figure 6. Audio Switching Waveform in the Frequency Domain.

Modifications to the receiver caused no degradation in the receiver performance and did not affect the received signal quality in any detectable manner. The modifications required to implement FCBM capabilities on standard FAA cab transmitters and receivers has no effect on the normal operating characteristics of the modified transmitters and receivers.

IV. EQUIPMENT MODIFICATION

A. General. FAA delivered the equipment detailed in Table 4 to Ohio University on July 17, 1979 for modification to FCBM operation and production of transportable demonstration pallets. The equipment was bench-checked in the unmodified state and found to operate within specifications. Both transmitter and receiver units were retuned to 123.2 MHz for system testing using this frequency and crystals were obtained.

The transmitter/receiver pair was mounted in one rack cabinet and the tower cab control units in another, for portability. Appropriate cable harnesses were fabricated. Figures 7 and 8 show the completed cabinets and equipment. Two antenna masts were obtained and modified to accept the antennas supplied by FAA, as shown in Figure 9.

For evaluation of FCBM operation, two VHF transceivers equipped for field operation were made available, one modified for variable-signal-level output and the other used for receive-only monitoring of the channel (see Figure 10).

B. Modification of Transmitter and Receiver. The transmitter and receiver were each modified by the addition of a printed circuit board. The circuit boards are mounted in the respective units and are controlled by a third circuit board mounted in a separate box.

The schematic for the transmitter board is shown in Figure 11. The switching waveform is received from the control and sequencer board and used to control the transmitter power output. Control of the transmitter power is achieved by multiplying the transmitter power control signal by the switching waveform in an analog multiplier. This additional circuitry is added within the automatic power control loop in the transmitter. Figure 12 shows the modifications to the transmitter circuitry.

The receiver board operates by sampling the AGC line of the receiver. The value of the AGC filter capacitor at RE5 in Figure 13 was changed from $10\ \mu\text{f}$ to $0.68\ \mu\text{f}$. The time constant of the AGC circuit is such that it reaches steady state conditions within 3 msec of a change in the RF signal level. When the transmitter carrier is ramped down to zero output, the AGC circuit is given 3 msec to settle. After the settling time, the AGC signal is compared to three preset levels to detect the level of the interfering signals. The comparator outputs are connected to the display board to be latched for display. Figure 14 shows the schematic of the receiver board.

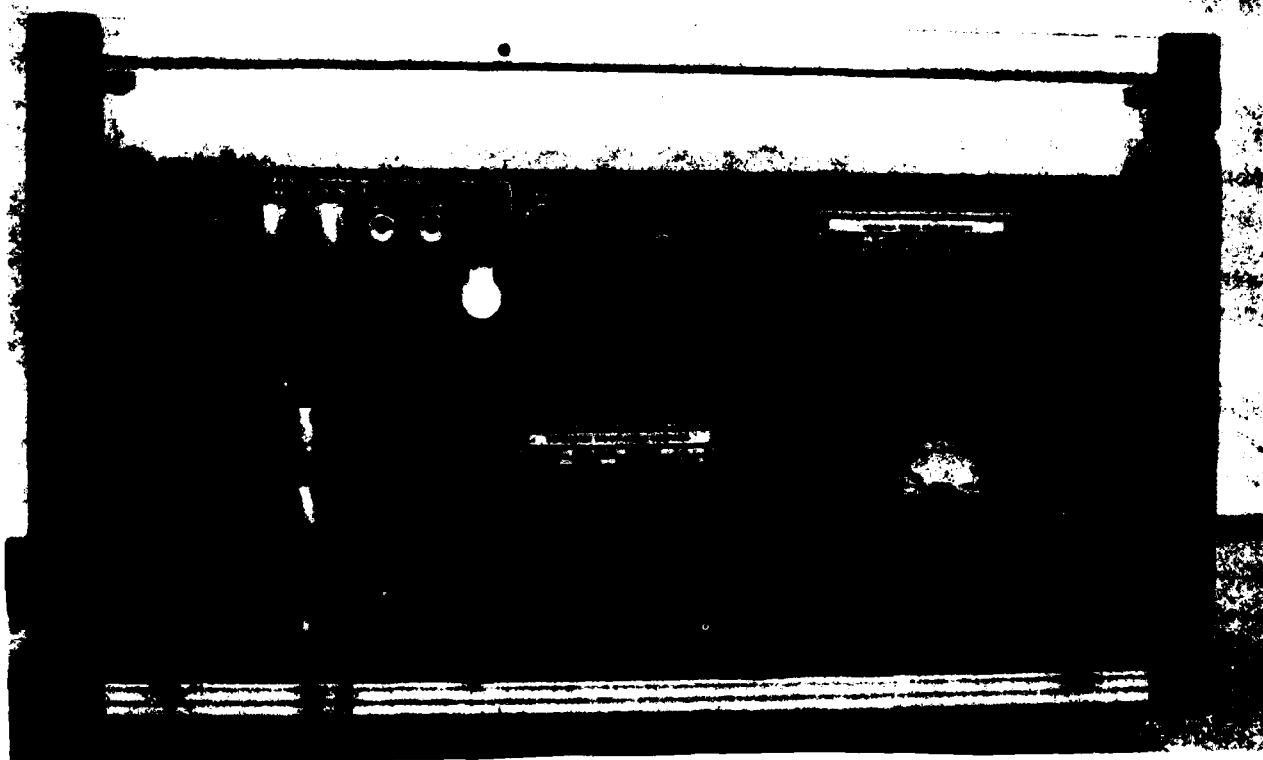

Figure 7. Receiver and Transmitter.

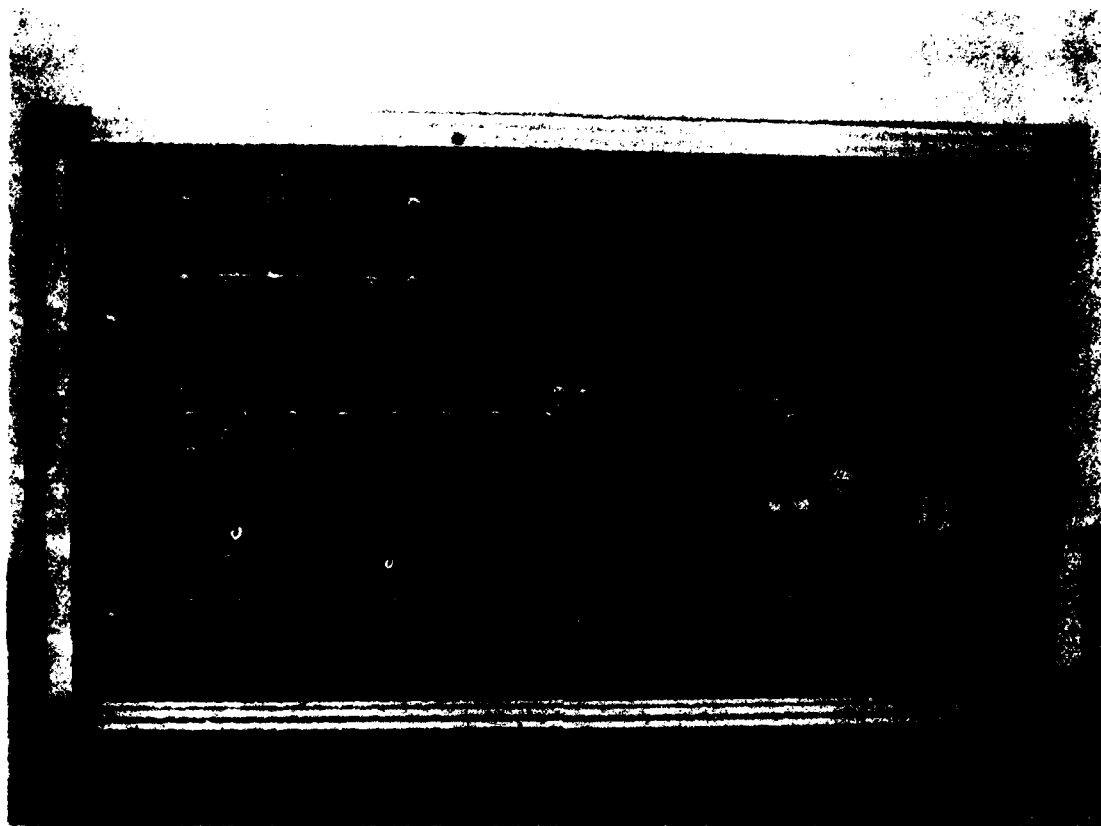

Figure 8. Cab Control Unit.

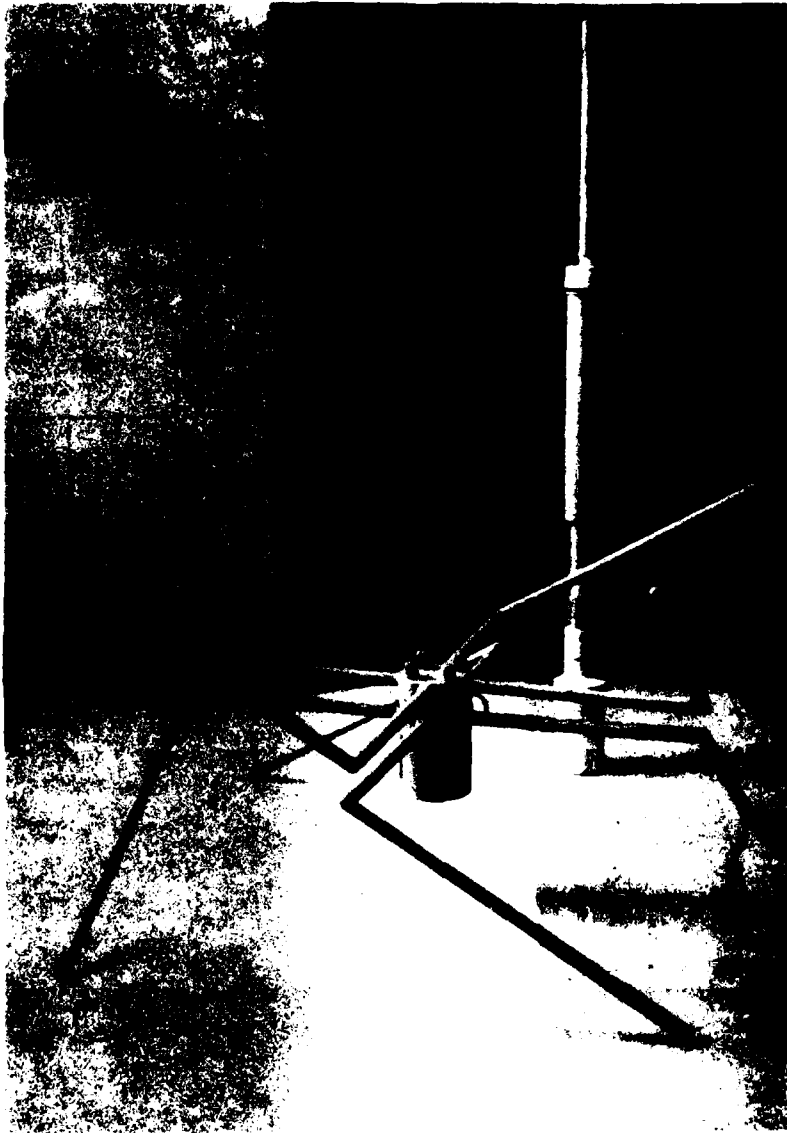

Figure 9. Receiving and Transmitting Antennas.



Figure 10. Monitor Receiver.

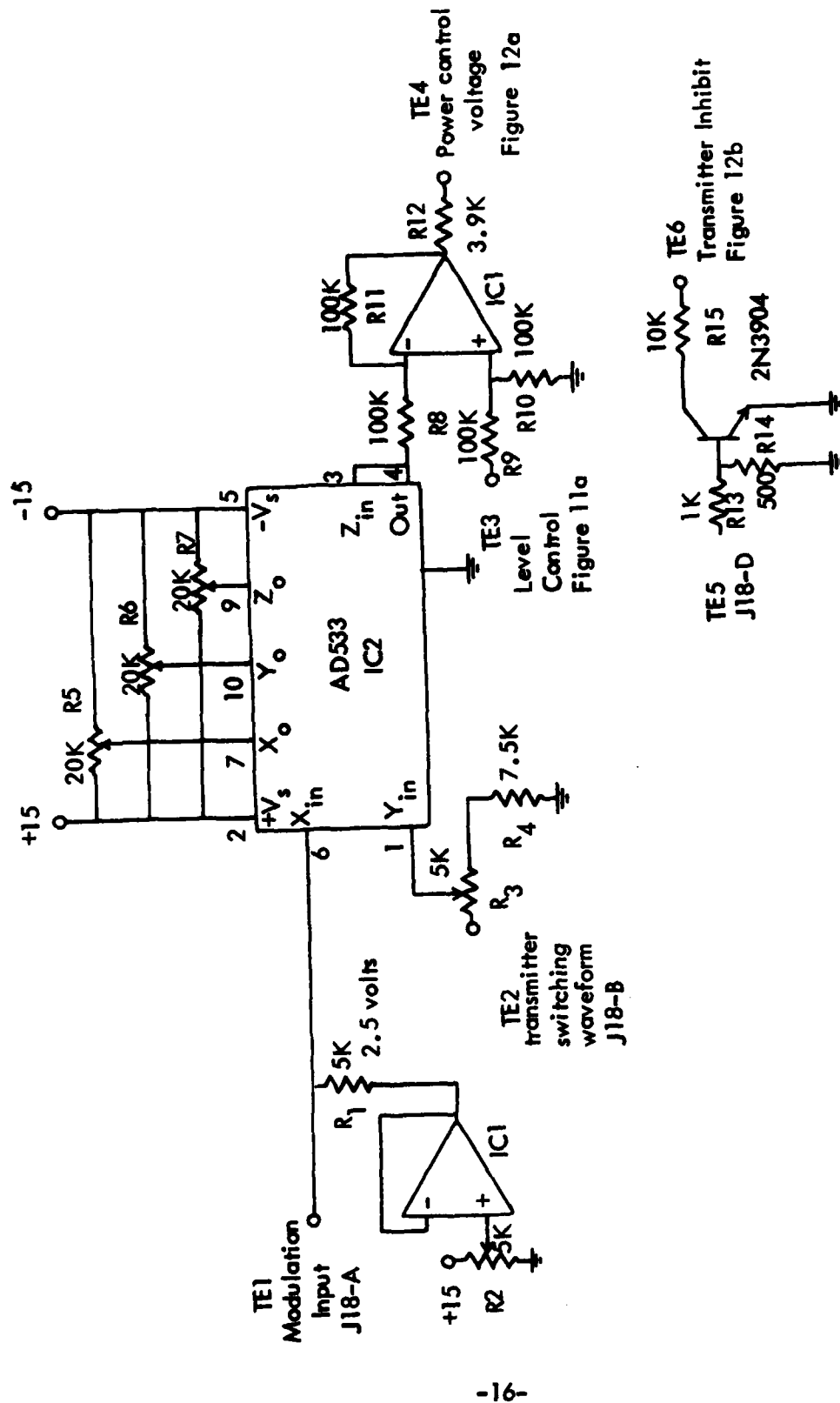
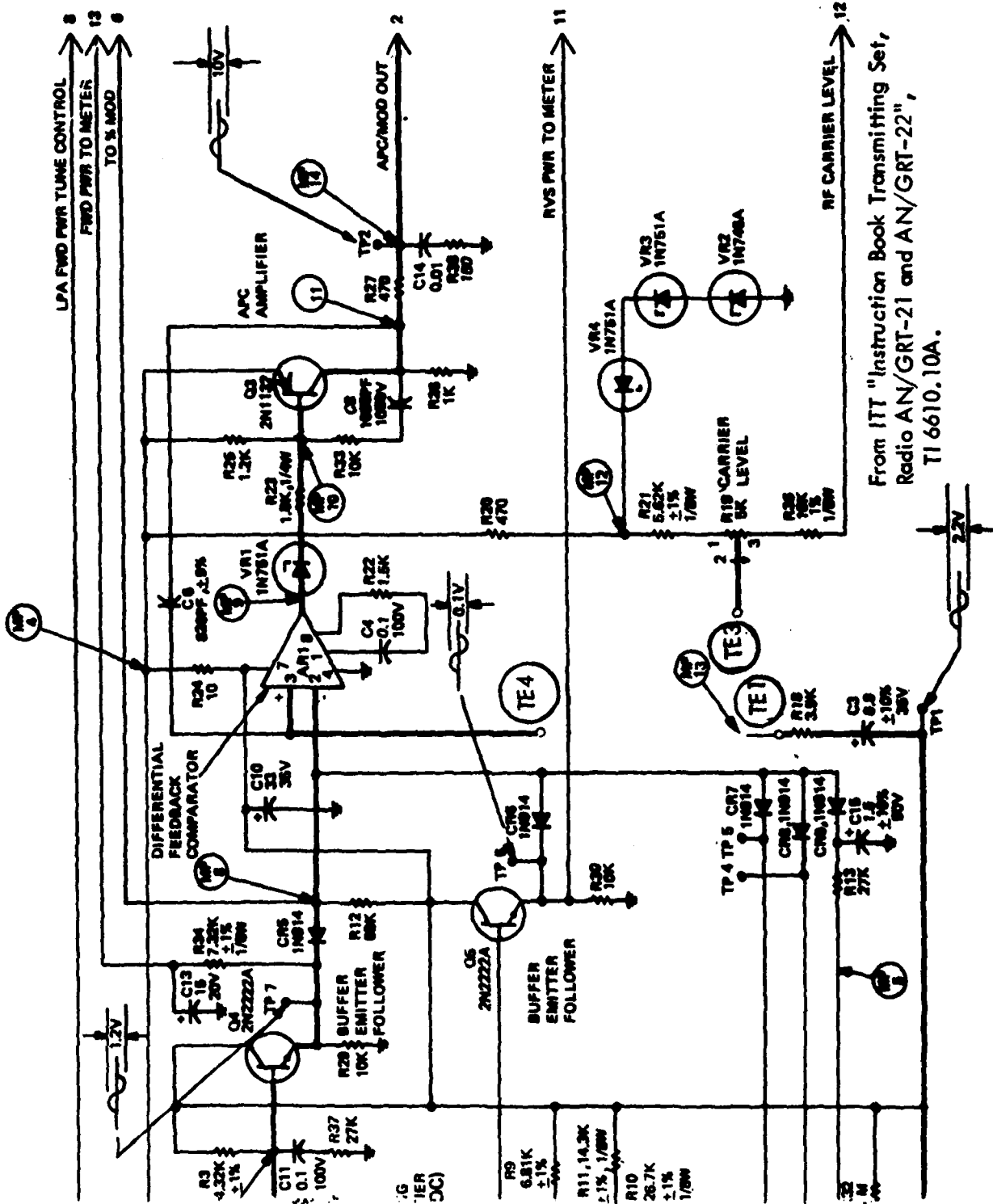

Figure 11. FCBM Transmitter Control Board.



From IIT "Instruction Book Transmitting Set,
Radio AN/GRT-21 and AN/GRT-22",
TI 6610.10A.

Figure 12a. Transmitter Modifications (Board A6).

From ITT "Instruction Book
Transmitting Set, Radio AN/GRT-
21 and AN/GRT-22", TI 6610.
10A.

EQUIPMENT MODIFICATIONS
CHAP 210 CHANGES
C3 ADDED, 22UF ± 10% 15V
C3 ADDED, 22UF ± 10% 15V
R23 ADDED, 1K
R24 ADDED, 50K
R25 ADDED, 15K
G10 ADDED, 2N2807A

NOTES:

- UNLESS OTHERWISE SPECIFIED:
1. RESISTANCE VALUES ARE IN OHMS ± 1% 1/8W
2. ALL CAPACITANCE VALUES ARE IN MICROFARADS 10% 50V
3. ALL VOLTAGE MEASUREMENTS TAKEN WITH A HIGH INPUT IMPEDANCE METER (MP 427 OR EQUIVALENT).

TEST POINT/MEASURING POINT VOLTAGES

UNKEYED	KEYED
TP1	0VDC
TP2	0VDC
TP3	0VDC
TP4	20VDC
TP5	16.5VDC
TP6	20VDC
TP7	20VDC
TP8	1.0VDC
MP1	20.0 ± 0.5VDC
MP2	20 TO 24 VDC
MP3	20.0 ± 0.5VDC
MP4	20 TO 24 VDC
MP5	20.0 ± 1.0 VDC
MP6	20.0 ± 1.0 VDC
MP7	0 VDC
MP8	20.0 ± 1.0VDC
MP9	0VDC
MP10	20.0 ± 1.0VDC

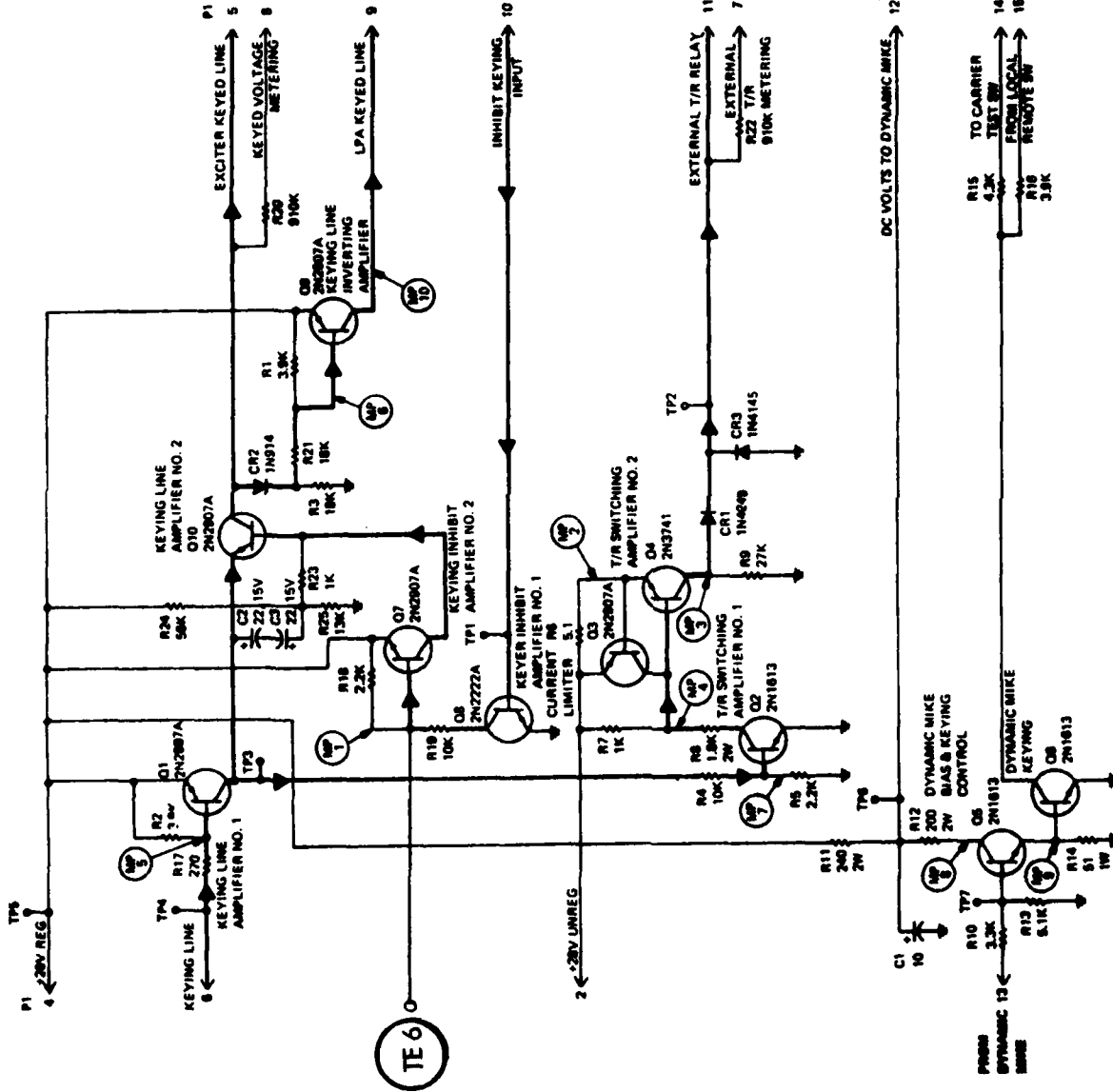
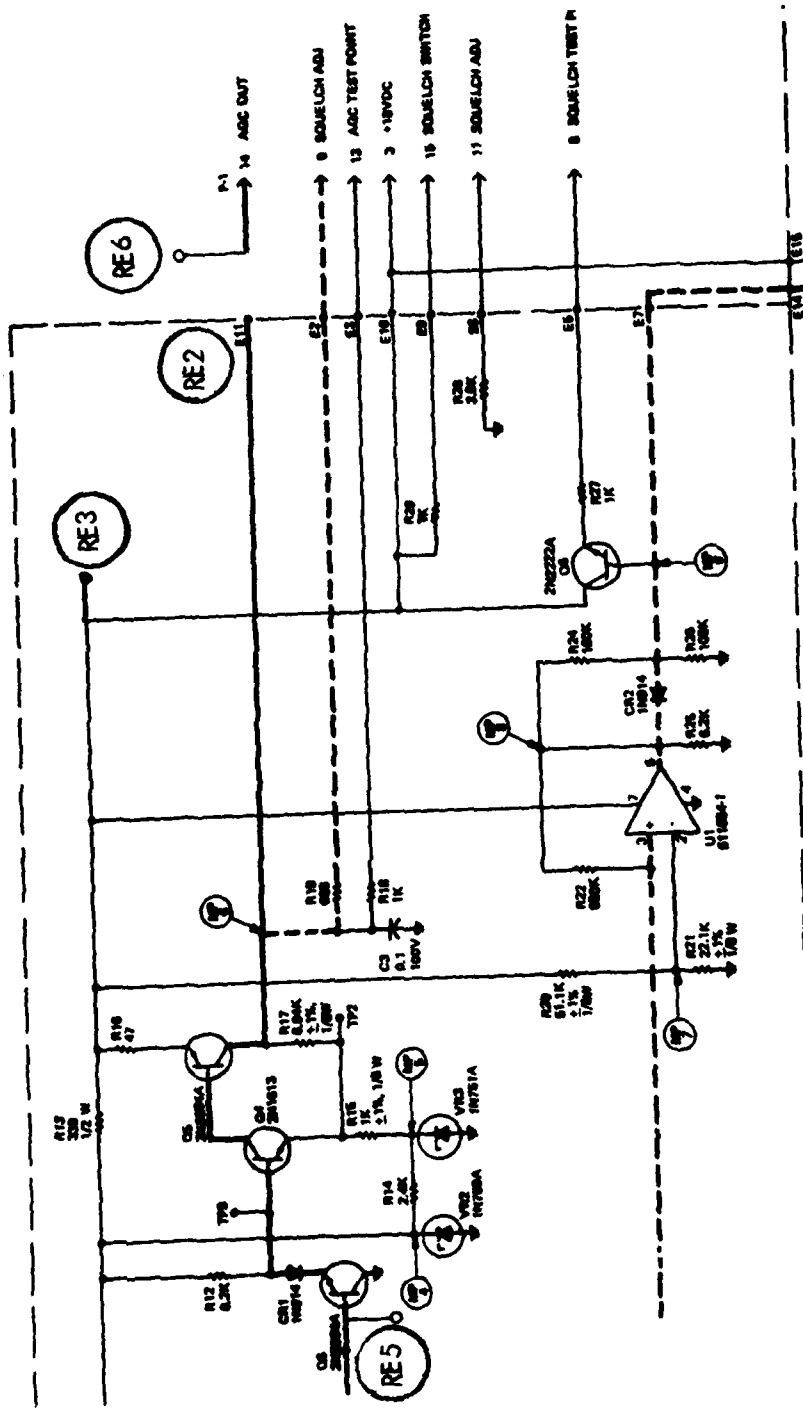
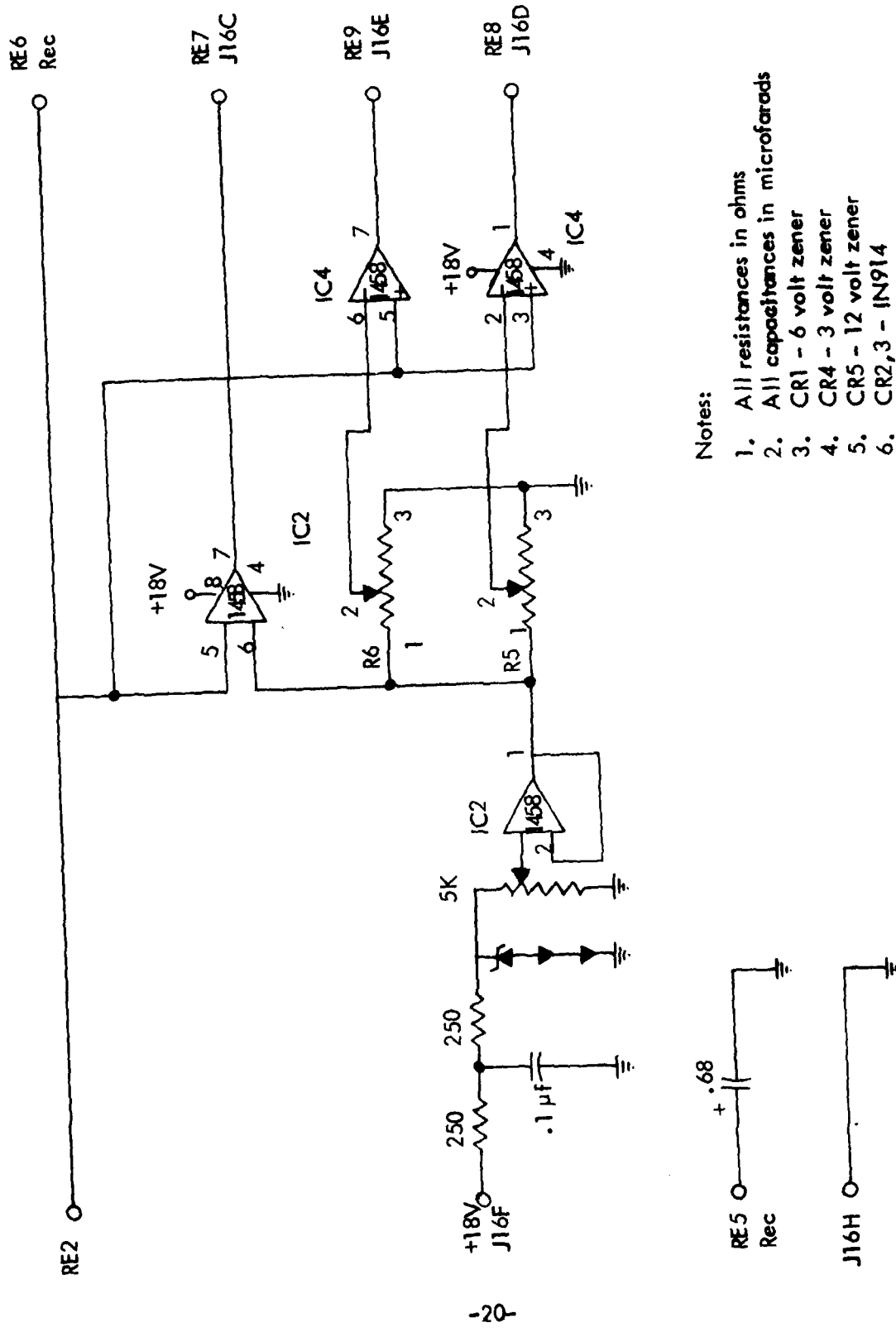

Figure 12b. Transmitter Modifications (Board A2).



From ITT Instruction Book
Receiver, Radio AN/GRF
24 and AN/GRR-24, TI
6620.2A.

Figure 13. Receiver Modifications (Board A3).



- Notes:
1. All resistances in ohms
 2. All capacitances in microfarads
 3. CR1 - 6 volt zener
 4. CR4 - 3 volt zener
 5. CR5 - 12 volt zener
 6. CR2,3 - IN914

Figure 14. Receiver Board.

Description of Equipment	Equipment Type
VHF-Transmitter	T-1108
VHF-Receiver	AN/GRR23
Transmitter Antenna	FA-8132C
Receiver Antenna	FA-9429
Audio Chassis	FA-9334-1
Audio Module	FA-9334-2
Lamp Module	FA-9334-3
Selector Chassis	FA-9334-5
Selector Module	FA-9334-6
Blank Panel	FA-9334-7
Jack Unit	FA-9334-8
Power Supply Assembly	FA-9334-4
Power Supply Module	FA-9334-12

Table 4. GFE Equipment Received by Ohio University.

The schematic for the phoneme interval detector (PID) is shown in Figure 15. IC 16 with the associated resistors and diodes forms a full-wave rectifier. The modulation voltage from the transmitter is fed through C1 and rectified. The rectified signal is compared to a reference voltage in IC15. When level of the rectified modulation voltage is below the reference value, transistor Q1 is shut-off and capacitor C2 is allowed to charge through resistor R11. When transistor Q1 remains off for more than 7 msec, capacitor C2 charges to half the power supply voltage triggering the comparator in IC 14. The output of IC 14 goes low indicating to the switching delay generator that a 7 msec silence has occurred in the modulation waveform and a sample should be taken.

The switching delay generator is shown in Figure 16. Dual timer in IC 13 generates the minimum and maximum time duration between samples. Each cycle of the sampling interval starts when the timers are reset. Timer A generates a 0.5 sec pulse during which sampling is inhibited. After timer A times out, the switching delay generator waits for a low indication from the PID to enable another sample. If signal from the PID is not received

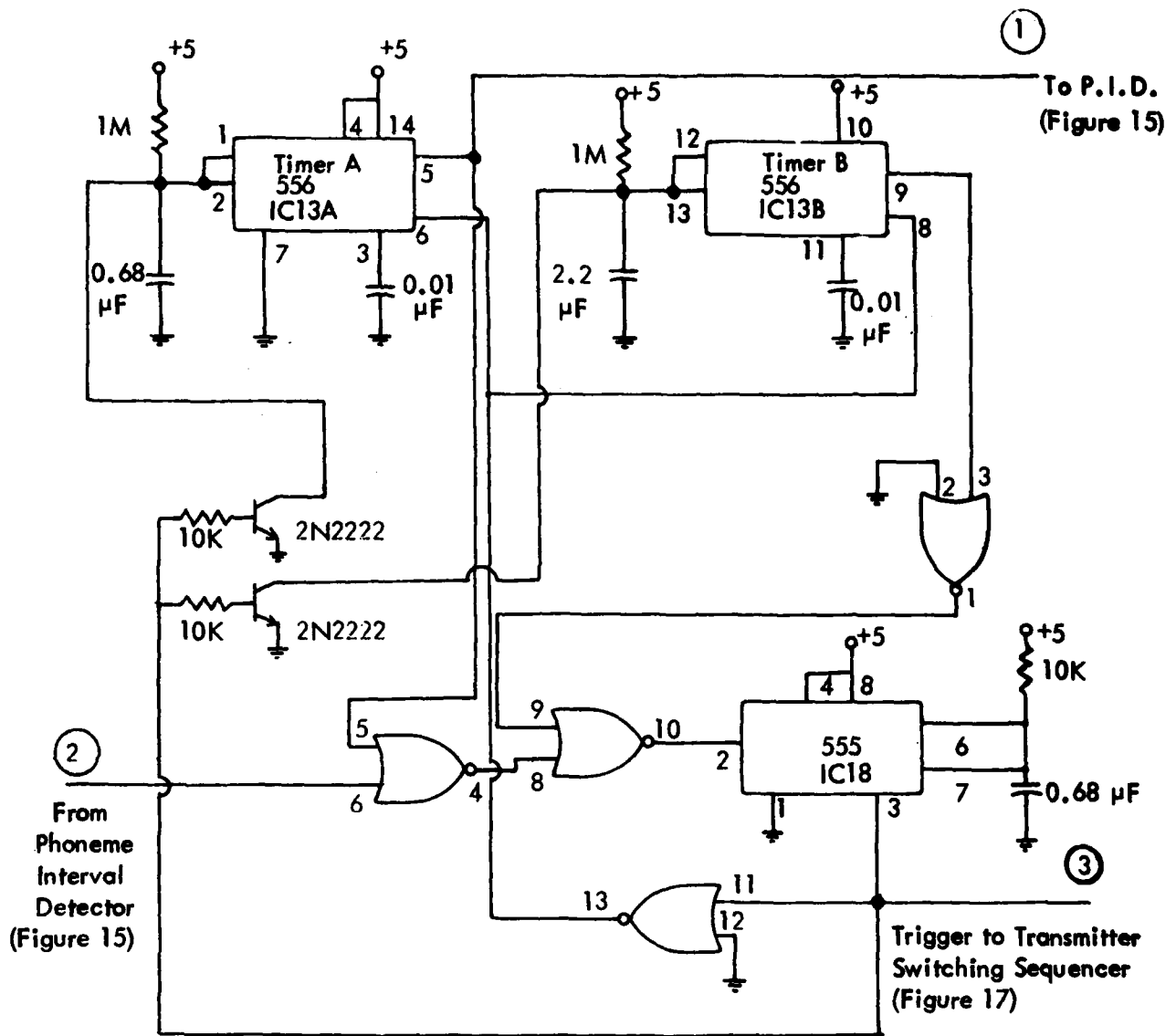

Figure 16. FCBM Transmitter Switching Delay Generator.

before timer B times out (1.5 sec), then the signal from timer B triggers the timer in IC 18 to generate a sample pulse. The signal from IC 18 triggers a sample pulse in the switching sequencer circuit and resets the timers in IC 13 to start another cycle. The PID eliminates the possibility of a synchronous blindspot caused by two FCBM-equipped transmitters that were sampling at the same time and also reduces the interruption of information by sampling generally during intervals when no modulation is being transmitted.

The schematic for the switching sequencer circuit is shown in Figure 17. This circuit generates the transmitter carrier switching waveform along with the signals which enable the receiver sampling. The input pulse from the switching delay generator toggles the flip-flop in IC 3-A. The Q output from this flip-flop disables the preset function on the shift registers in IC's 4, 5 and 6. The parallel outputs from these shift registers are initially all high. The outputs are summed through a bank of weighting resistors to achieve any desired rising and falling waveform. The output of this network is initially at its highest value. The serial input to the shift registers is initially low since the flip-flop in IC 3-B was cleared at the beginning of the cycle. Each clock pulse, the frequency of which is controlled by IC 7, propagates another zero into the shift register and the corresponding resistor no longer contributes any current to the summing junction of IC 8-A. After 15 clock cycles all the shift register outputs are low and the counter in IC 2 is enabled. The output of the shift register remains at its lowest level through 12 counts of the clock signal. On the twelfth count, nand gate IC 11-A sets the flip-flop in IC 3-B which causes the serial input to the shift register to be a high level. The high level propagates through the shift register and, after 15 counts, the high level is restored to the output. IC 11-B detects the end of the cycle and resets IC 3-A. IC 11 C-D and IC 1 A-B decode the states of the timing circuit to produce the signals required to synchronize the receiver and transmitter boards. IC 8 A-B and IC 9 amplify and filter the transmitter switching waveform to obtain the level required by the transmitter board.

The display board shown in Figure 18 accepts the comparator outputs from the receiver board and timing signals from the control and sequencer board and latches the level of the interfering signal for display on the front panel. The display board which mounts in a spare control panel in the cab control unit also provides a switch from which the operator can disable the FCBM function.

Figure 19 is the cabling diagram which shows the interconnection between the circuit boards.

V. INVESTIGATORS AND ACKNOWLEDGEMENTS

The following personnel contributed to the work performed under this contract:

Dr. Robert W. Lilley served as consultant and provided much support and critique during the course of this contract and Dr. Joe Essman acted as consultant in the area of mathematical waveform analysis. Mr. George Foster, inventor of the FCBM concept, acted as project consultant and made many valuable suggestions for improvement of the operational characteristics of the monitor.

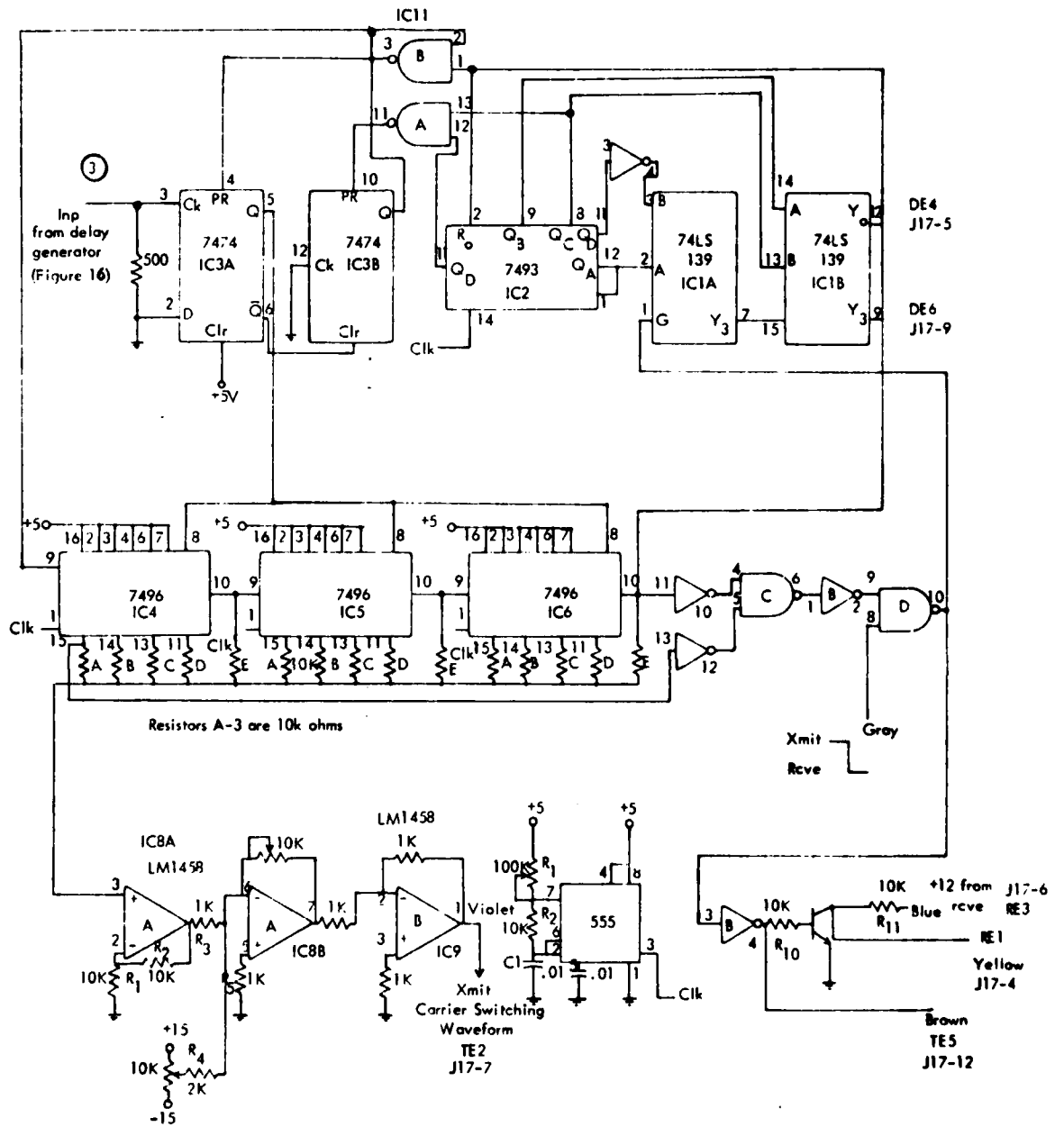

Figure 17. Sequencer and Control Board.

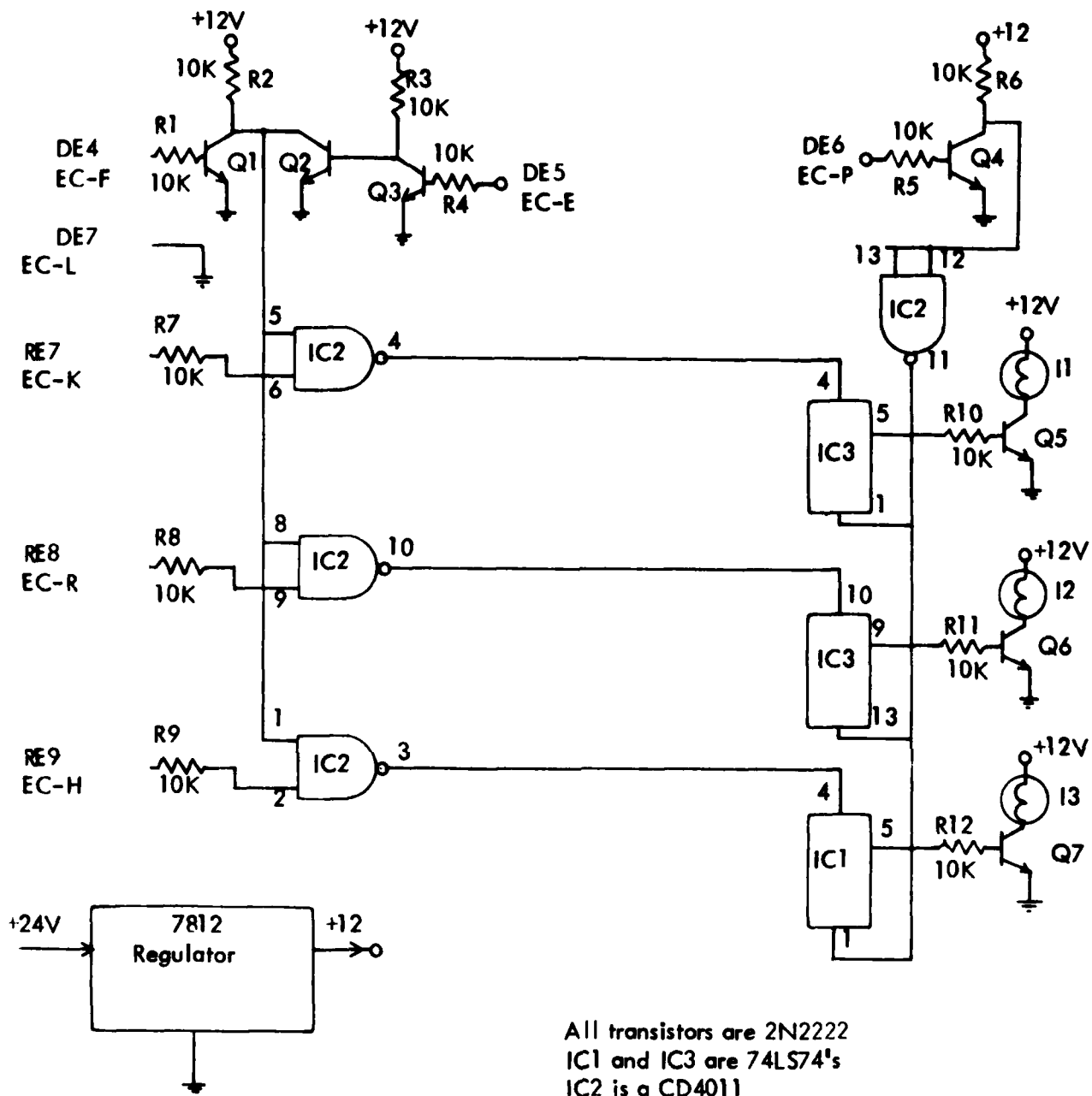

Figure 18. FCBM Display Board.

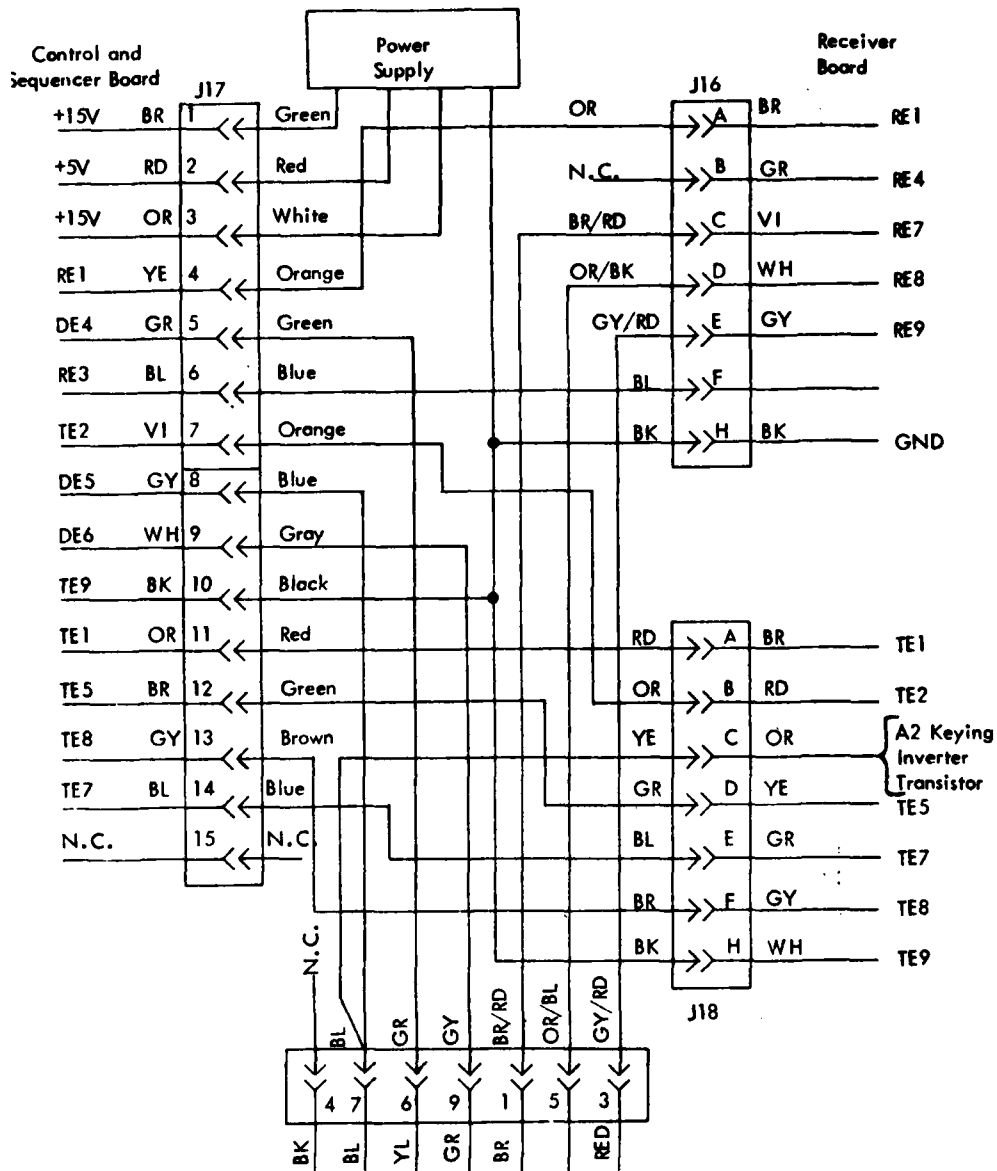

Figure 19a. Cabling Diagram.

Mr. Wendell Hensley and Mr. Ed Jones built, installed and troubleshot circuit boards. Mr. Tom Smith wrote the computer program to calculate the in-band harmonic distortion.

Dr. Richard H. McFarland served as Project Director.

VI. REFERENCES

- [1] "Dutch Differ with Spanish on Tenerife", Aviation Week and Space Technology, October 15, 1979.
- [2] "Update on San Diego", The AOPA Pilot, December 1978.
- [3] Tosi, Oscar, "A Method for Acoustic Segmentation of Continuous Sound into Pauses and Signals", Dissertation, The Ohio State University, 1965.
- [4] Schwartz, Mischa, "Information Transmission, Modulation and Noise", Second Edition, McGraw-Hill Book Company, 1970.

APPENDICES

Appendix A. Out-of-Band Frequency Response Program

```
REAL*8 AN,PI,A,SUMSQ,X
PI=3.14159
SUMSQ=0.0
C THE LIMITS OF I REPRESENT THE BAND OF FREQUENCIES FOR
C WHICH THE POWER IS TO BE CALCULATED. THE FREQUENCY IS
C I HZ ADDED TO THE CENTER FREQUENCY OF THE CARRIER.
C ON 100 I=62500,87500
C CALCULATE THE RADIAN FREQUENCY
X=2.*(I)*PI
C CALCULATE THE MAGNITUDE OF THE FOURIER SERIES AT I HZ.
AN=2./(0.497500-0.495000)*(DCOS(X*0.495000)-DCOS(X*0.497500))/(X*X)
C CALCULATE THE SUM OF THE POWER FROM EACH FREQUENCY COMPONENT.
SUMSQ=SUMSQ+AN**2
100 CONTINUE
WRITE(6,200) SUMSQ
200 FORMAT(' ',SUMSQ=' ',015.6)
STOP
END
```

THIS PAGE IS BEST QUALITY PRACTICABLE
FROM COPY FURNISHED TO DDC

Appendix B. In-Band Frequency Response Program

```

C
C
C (K1):.....SPECIFIES ONE HALF THE TOTAL NUMBER OF REAL INPUT
C          SAMPLES TO BE ZEROED (SIMULATING FCBM MONITORING
C          TIME) IF OPTION (IS1) = 1
C
C (XK2):.....SPECIFIES THAT FRACTION OF THE MAGNITUDE OF THE OUT-
C          PUT AT THE CARRIER FREQUENCY HARMONIC BELOW WHICH
C          AN FFTA MAGNITUDE WILL NOT BE DISPLAYED.  VALID
C          WHEN THE VALUE OF (IS3) = 2
C
C (IS1):.....(1) = PERMITS FIRST (K1) SAMPLES AND LAST (K1) SAMPLES OF
C          INPUT DATA TO FFTA TO BE ZEROED FOR FCBM OFF TIME
C          (2) = NO FCBM ZEROING
C
C (IS2):.....(1) = THE MAGNITUDE OF THE OUTPUT OF FFTA WILL BE SCALED
C          TO YIELD FOURIER COEFFICIENTS
C          (2) = THE MAGNITUDE OF THE OUTPUT OF FFTA WILL BE SCALED
C          TO YIELD THE VALUES OF THE DISCRETE FOURIER TRANS-
C          FORM
C
C (IS3):.....(1) = PRINT ALL OUTPUT OF FFTA (MAGNITUDES, DETERMINED BY
C          VALUE OF (IS2)) UP TO AND INCLUDING FOLDING FREQUENCY
C          (2) = PRINT ONLY THOSE VALUES (MAGNITUDES) OUTPUT FROM FFTA
C          THAT MEET THE CONDITION OF (XK2)
C

```

```

      DIMENSION FR(16384),FI(16384)
      DATA PCMD,FI,K,FC,FM,FS,K1,XK2,IS1,IS2,IS3/0.00,16384*0.,14,10240.
      *,1280.,31920.,00,0.005,1,1,1/

```

```

C
C.....DEFINING PROGRAM VARIABLES
C
C

```

```

      T=1./FS
      XK1=K1
      XIS1=2-IS1
      TADN=XK1*T*2.*XIS1
      N=2.**K
      XN=N
      FB=FS/XN
      KFC=FC/FB
      FML=FC-FM
      KFML=FML/FB
      FPU=FC+FM
      KFPU=FPU/FB
      J1=XN/12.+1.
      I101=XN*1
      WC=2.*3.141592654*FJ
      WC=2.*3.141592654*FL
      WM=2.*3.141592654*FM
      JIF=1./2.+1
      DO 10 I=1,N
      XI=I-1
      IXI=XI*I

```

THIS PAGE IS BEST QUALITY PRACTICABLE
FROM COPY FURNISHED TO DDC

```

C
C
C.....CALCULATING THE SAMPLES OF THE TIME FUNCTION
C
C
10  FR(I)=(1.+PCMD*COS(WM*TXI))*COS(WC*TXI)
    GO TO (11,12),IS1
C
C
C.....FCBM ZEROING; (K1) ZEROES AT EACH END OF REAL INPUT ARRAY
C
C
11  DO 13 I=1,K1
     J=N-K1+1
13  FR(J)=0.0
     DO 14 I=1,K1
14  FR(I)=0.0
12  CALL FFTA(FR,FI,K)
     WRITE(6,19) FC,KFC,N,IS1,K1,FML,KFML,FS,IS2,FMU,KFMU,T,
     *IS3,XK2,FM,TTOT,FD,TDUN,PCMD
19  FORMAT(1X,'SQUARE',14X,'HARMONIC',/,22X,'NUMBER',/,22X,'-----',/,
     *4X,'FC =',F8.1,' HZ' (',14,')',9X,'NO. OF SAMPLES =',9X,
     *15,16X,'IS1 =',16,5X,'K1 =',16,77,1X,'FC-FM =',F8.1,
     *' HZ' (',14,')',9X,'SAMPLING FREQUENCY =',F12.1,' HZ',11X,
     *'IS2 =',16,77,1X,'FC+FM =',F8.1,' HZ' (',14,')',9X,
     *'SAMPLING INTERVAL =',F13.4,' SEC.',9X,'IS3 =',16,5X,
     *'XK2 =',16.3,77,4X,'FM =',F8.1,' HZ',18X,'SAMPLING PER',
     *'K1UD =',F15.4,' SEC.',77,1X,'FUNDAMENTAL FREQ. =',F5.1,
     *' HZ',9X,'FCBM OFF TIME =',F17.5,' SEC.',9X,'MODULATION',
     *' =',F5.2,777)
C
C
C.....CALCULATING MAGNITUDES OF FFTA OUTPUT; MODE DETERMINED
C BY VALUE OF (IS2)
C
C
FTHD=0.0
DO 300 M=1,2048
FTHD=FTHD+(FR(M)*FR(M)+FI(M)*FI(M))/(XN*XN)
300 CONTINUE
DO 355 M=2050,NFF
FTHD=FTHD+(FR(M)*FR(M)+FI(M)*FI(M))/(XN*XN)
355 CONTINUE
FDES=(FR(2049)*FR(2049)+FI(2049)*FI(2049))/(XN*XN)
THD=FTHD*100./FDES
WRITE(5,350) THD
350 FORMAT(' THE TOTAL HARMONIC DISTORTION = ',F14.5,' PERCENT')
DO 30 M=1,NFF
GO TO (20,25),IS2
20  FR(M)=SQRT(FR(M)*FR(M)+FI(M)*FI(M))/XN
GO TO 30
25  FR(M)=SQRT(FR(M)*FR(M)+FI(M)*FI(M))/FS
30  CONTINUE
GO TO (31,46), IS3

```

```

C
C.....FORMAT ALGORITHM TO OUTPUT ALL MAGNITUDES;
C      SIX COLUMNS ON 132 CHARACTER/LINE PAGE
C
C
31  DO 40 I=1,J1
      IH=I-1
      J2=1+J1
      J3=I+2*J1
      J4=I+3*J1
      J5=I+4*J1
      J6=I+5*J1
      J2H=J2-1
      J3H=J3-1
      J4H=J4-1
      J5H=J5-1
      J6H=J6-1
40  WRITE(6,41) IH,FR(I),J2H,FR(J2),J3H,FR(J3),J4H,
      *FR(J4),J5H,FR(J5),J6H,FR(J6)
41  FORMAT(1X,6(17,F14.4))
      GO TO 60
C
C
C.....CALCULATING THE FRACTION (XK2) OF THE OUTPUT DATA AT THE
C      CARRIER FREQUENCY USED AS THE CUT-OFF FOR SELECTIVE OUT-
C      PUT PRINTING
C
C
46  IPH=FC/FD+1.
      CMPR=FR(IPH)*XK2
      ICNT=1
C
C
C.....SELECTING OUTPUT DATA TO BE PRINTED AS PER (XK2)
C
C
      DO 50 I=1,NFF
      IF (CMPR-FR(I)) 45,50,50
45  FR(ICNT)=FR(I)
      FI(ICNT)=I-1
      ICNT=ICNT+1
50  CONTINUE
      ICNT=ICNT-1
      WRITE(6,50) XK2,ICNT
50  FORMAT(1X,'*****THE FOLLOWING LIST CONTAIN',
      *'S THOSE HARMONICS WHICH ARE GREATER THAN',/,19X,'OR EQUAL TO',
      *F6.3,' OF THE AMPLITUDE AT THE CARRIER FREQUENCY.'
      *,/,19X,'THE NUMBER OF VALID ENTRIES IN THE LIST =',15,///)
C
C
C.....FORMAT ALGORITHM TO OUTPUT DATA SELECTED AS PER (XK2)
C
C
      IF (ICNT/6*6-ICNT) 52,51,52
51  JKUW=ICNT/6

```

```
GO TO 53
52 JKOW=ICNT/6+1
53 DO 54 I=1,JKOW
  NUM=I*6
  L2=I+JKOW
  L3=L2+JKOW
  L4=L3+JKOW
  L5=L4+JKOW
  L6=L5+JKOW
  LH1=F1(I)
  LH2=F1(L2)
  LH3=F1(L3)
  LH4=F1(L4)
  LH5=F1(L5)
  LH6=F1(L6)
54 WRITE(6,55) NUM,LH1,FR(I),LH2,FR(L2),LH3,FR(L3),LH4,
  *FR(L4),LH5,FR(L5),LH6,FR(L6)
55 FORMAT(15,4X,6(17,L13.4))
60 STOP
END
```

THIS PAGE IS BEST QUALITY PRACTICABLE
FROM COPY FURNISHED TO DDC

Appendix C. Graph of Signal Strength Vs. Distance

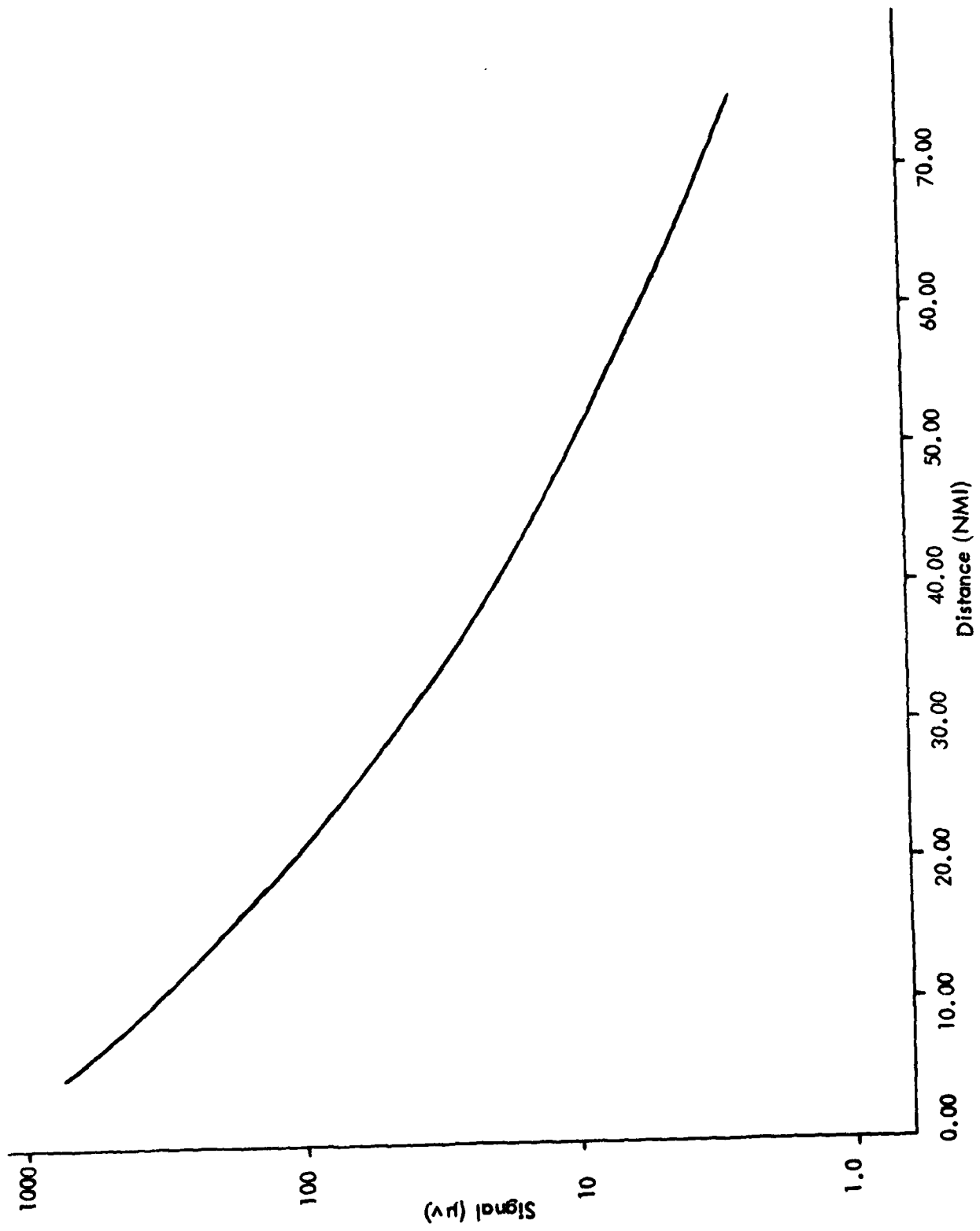

Figure C-1. Graph of Signal Strength Vs. Distance.

Appendix D. Circuit Board Photographs

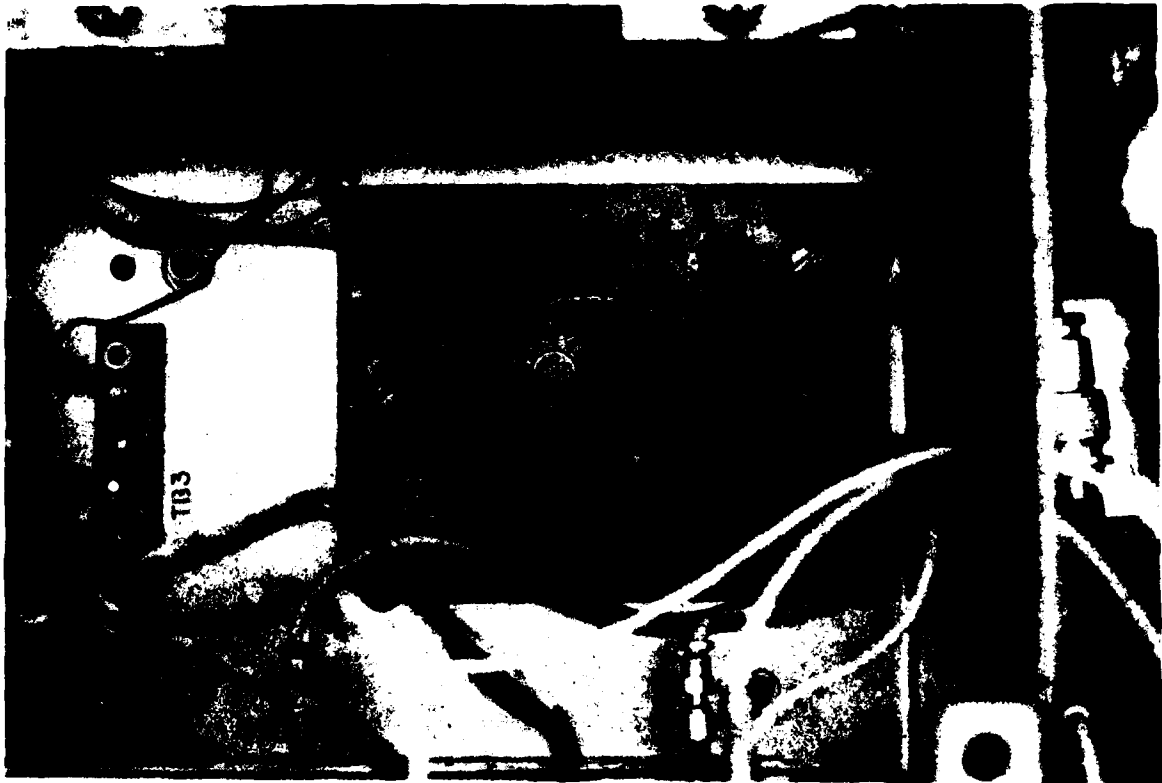

Figure D-1. Transmitter Board Mounted in the Transmitter.

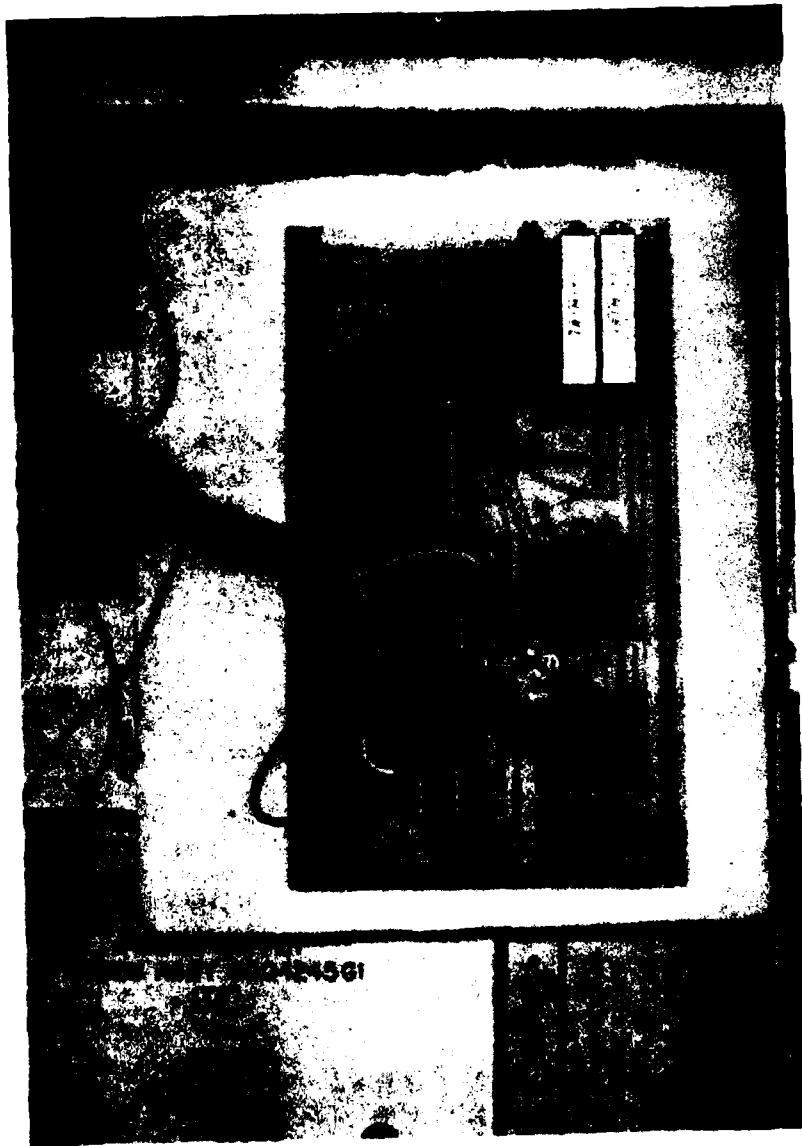

Figure D-2. Receiver Board.

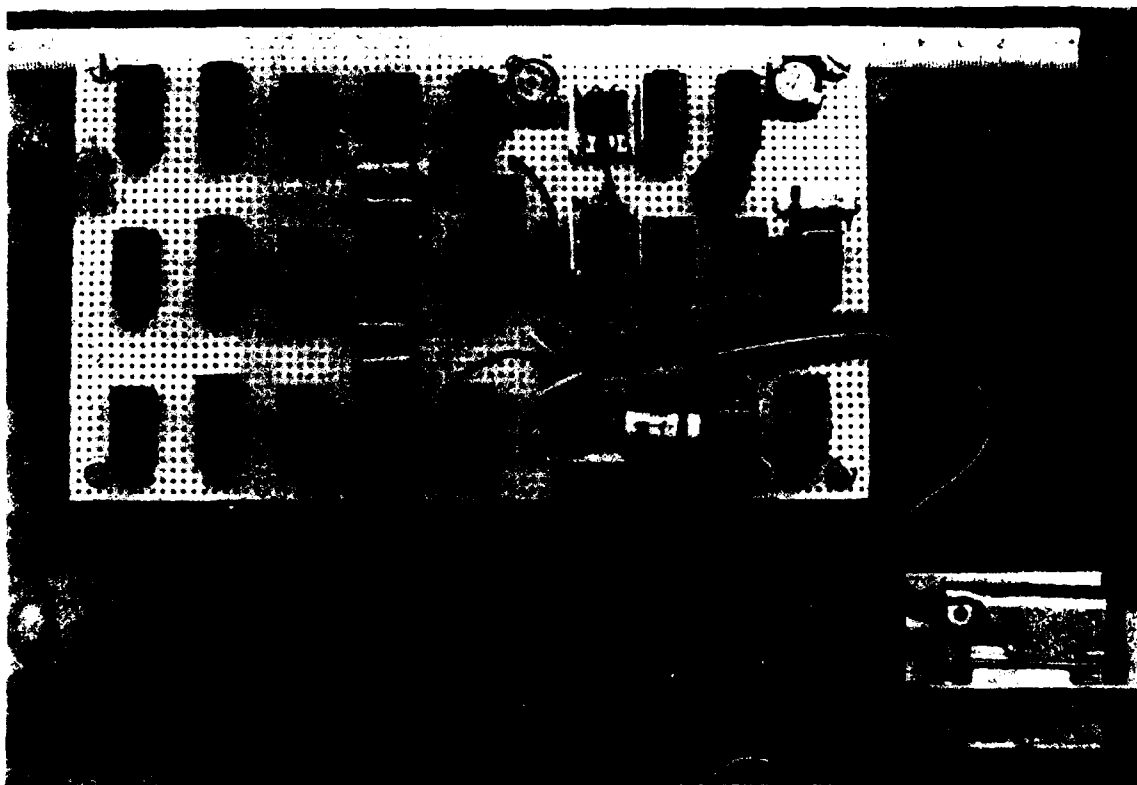

Figure D-3. Control and Sequencer, PID and Delay Generator Circuitry.