

12

GRADUATE AERONAUTICAL LABORATORIES
CALIFORNIA INSTITUTE OF TECHNOLOGY

~~LEVEL~~

NSRDC FAIRED TOWLINE TESTS
IN THE HIGH SPEED
WATER TUNNEL

DTIC
SELECTE
APR 10 1980
C D

ACA 082989

This document has been approved
for public release and sale; its
distribution is unlimited.

Firestone Flight Sciences Laboratory

Guggenheim Aeronautical Laboratory

Karman Laboratory of Fluid Mechanics and Jet Propulsion

SDC FILE COPY

Pasadena

80 4 9 005

REPORT DOCUMENTATION PAGE		READ INSTRUCTIONS BEFORE COMPLETING FORM
1. REPORT NUMBER GALCIT Report HSWT 1137	2. GOVT ACCESSION NO.	3. RECIPIENT'S CATALOG NUMBER
4. TITLE (and Subtitle) NSRDC FAIRED TOWLINE TESTS IN THE HIGH SPEED WATER TUNNEL		5. TYPE OF REPORT & PERIOD COVERED Tech Report 5/17/79 - 6/8/79
7. AUTHOR Paul Baloga		6. PERFORMING ORG. REPORT NUMBER
9. PERFORMING ORGANIZATION NAME AND ADDRESS California Institute of Technology Hydrodynamics Laboratory Pasadena, CA 91125		8. CONTRACT OR GRANT NUMBER(s) N00014-78-C-0790 ^{CL}
11. CONTROLLING OFFICE NAME AND ADDRESS Office of Naval Research Arlington, VA 22217		10. PROGRAM ELEMENT, PROJECT, TASK AREA & WORK UNIT NUMBERS NR 062-626
14. MONITORING AGENCY NAME & ADDRESS (if different from Controlling Office) See 11 above		12. REPORT DATE October 1979
		13. NUMBER OF PAGES 23
		15. SECURITY CLASS. (of this report) Unclassified
		15a. DECLASSIFICATION/DOWNGRADING SCHEDULE
16. DISTRIBUTION STATEMENT (of this Report) Approved for public release; distribution unlimited = 14 GALCIT-H-WT-1137		
17. DISTRIBUTION STATEMENT (of the abstract entered in Block 20, if different from Report) 9) Technical rept		
18. SUPPLEMENTARY NOTES		
19. KEY WORDS (Continue on reverse side if necessary and identify by block number) Faired Towline, three component coefficients, flexible rubber and aluminum models.		
20. ABSTRACT (Continue on reverse side if necessary and identify by block number) Lift, drag, and pitching moment data for aluminum and rubber models of a segment of the NSRDC towline are presented. Deflections on the rubber model were measured through a pitch angle range of +1° through -4° with water velocities ranging up to 68 feet per second. ←		

GRADUATE AERONAUTICAL LABORATORIES
CALIFORNIA INSTITUTE OF TECHNOLOGY

High Speed Water Tunnel

GALCIT Report No. HSWT-1137

NSRDC FAIRED TOWLINE TESTS
in the
HIGH SPEED WATER TUNNEL

Paul E. Baloga



Director, Low-speed
Experimental Facilities



Professor of Aeronautics

Pasadena, California
October 1979

TABLE OF CONTENTS

	<u>Page</u>
Abstract	3
Index of Runs	4
Index of Figures	5
Index of Tables	5
Tables	6
Discussion	17
Figures	20

Accession For	
NTIS GRA&I	<input checked="" type="checkbox"/>
DDC TAB	<input type="checkbox"/>
Unannounced	<input type="checkbox"/>
Justification	<input type="checkbox"/>
By _____	
Distribution/	
Availability Codes	
Dist	Available/or Special
A	

ABSTRACT

Lift, drag and pitching moment data for aluminum and rubber models of a segment of the NSRDC towline are presented. Deflections on the rubber model were also measured through a pitch angle range of $+1^{\circ}$ through -4° with water velocities ranging up to 68 feet per second.

INDEX OF RUNS

Run No.	Model	Vel., ft/sec	Pitch, deg.	σ	Remarks
1	Aluminum	40	Vary	Vary	
2	"	—	—	—	N.G.
3	"	68	Vary	1.25	
4	"	Vary	-0.18	Vary	
5	Rubber	"	Vary	"	
6	"	40	"	3.18	Fabric covering loosened from body
7	"	"	"	"	Fabric repaired
8	"	50	"	2.34	
9	"	"	—	"	Repeat of 1 data point from Run 8
10	—	—	—	—	Balance Tare Run
11	Rubber	Vary	+1.00	Vary	
12	"	"	0.00	"	
13	"	"	-1.00	"	
14	"	"	-2.00	"	
15	"	"	-3.00	"	
16	"	"	-4.00	"	
17	"	50	-0.60	2.33	
18	"	Vary	-4.00	Vary	
19	"	"	+1.00	"	Model 10% truncated

INDEX OF FIGURES

<u>Fig.</u>		<u>Page</u>
1	High Speed Water Tunnel Circuit Schematic	20
2	Two-Dimensional Working Section Schematic	21
3	Cross-Section of Flexible Model	22
4	Models of Segment of NSRDC Faired Towline	23

INDEX OF TABLES

<u>Table</u>		<u>Page</u>
I	Nomenclature	6
II	Run Data and Three Component Coefficients Corrected for Balance Interactions	8
III	Measured Deflections on Rubber Model	15

TABLE I

Nomenclature

Designation

A	=	Planform area of foil, $B \times C$
B	=	Span of foil
C_c (LC)	=	Chord of foil
C_D (CD)	=	Drag coefficient, $D/q_0 A$
C_L (CL)	=	Lift coefficient, $L/q_0 A$
C_M (CM)	=	Pitching moment coefficient, $M/q_0 C A$
D, (DRAG)	=	Drag force, positive when acting in the direction of flow parallel to the longitudinal centerline of the working section.
L, (LIFT)	=	Lift force, positive when acting upward and normal to the direction of flow which is parallel to the longitudinal centerline of the working section.
M, (MOMENT)	=	Pitching moment, positive when tending to rotate the foil leading edge upward about an axis taken normal to the longitudinal centerline of the working section through the 25% chord point.
Nose	=	Leading edge
P_0 (PO)	=	Static pressure of water in working section, absolute
P_v (PV)	=	Vapor pressure of water at test temperature
q_0 (QO)	=	Dynamic pressure of water in working section, $\frac{1}{2} \rho V_0^2$
R_n (RN)	=	Reynolds number, $V_0 C / \nu$
T. E.	=	Trailing edge
V_0 (VO)	=	Water velocity in working section
W_m (WM)	=	Weight of mercury
W_w (WW)	=	Weight of water

TABLE I (Cont'd.)

α , (PITCH)	=	Pitch angle; angle of attack of foil measured between working section longitudinal centerline and foil chordline, positive when leading edge is rotated upward
ρ , (RHO)	=	Density of water
ν , (NU)	=	Kinematic viscosity of water
σ , (SIGMA)	=	Index of cavitation based on vapor pressure of water, $(P_0 - P_v)/q_0$
CCN	=	Card code number used to identify the nature of the data point as follows: CCN 110 = Pretest reference readings 120 = Model test data 130 = Post test reference readings
PSF	=	Pounds per square foot
PSFA	=	Pounds per square foot absolute
Aluminum	=	Rigid aluminum model
Rubber	=	Flexible silicone rubber model

Note: Equivalent nomenclature designation, used in computer printout Table II, appears in parenthesis.

TABLE II
RUN DATA AND THREE COMPONENT
COEFFICIENTS CORRECTED FOR BALANCE INTERACTIONS

PAGE

GALCIT REPORT
HSWT-1137

THREE COMPONENT

RUN DATA CORRECTED FOR BALANCE INTERACTIONS

CONSTANTS: TEMP= 73.70000 DEG F RHO= 1.93529 SLUG/CUFT
 PV= 59.25453 PSF NU= 0.10022E-04 SQFT/SEC
 MW= 62.20323 LBS/CUFT WM= 845.25391 LBS/CUFT
 LC= 0.20000 FT A= 0.10000 SQFT

RUN	CCN	CARD	VELOCITY VO,FT/SEC	PRESSURE PO,PSFA	PITCH DEG	QO PSF	RN 10 E-6	SIGMA	LIFT L,LBS	DRAG D,LBS	MOMENT M,FT-LB	CL	CD	CM	L/D
1	110	0	0.0	0.0	0.0	1539.6	0.796	1.30	0.0	0.0	-0.01	0.0113	0.0173	0.0014	0.65
1	120	1	39.89	2059.9	0.0	1539.6	0.796	1.30	1.7	2.7	0.04	0.0113	0.0173	0.0014	0.65
1	120	2	39.94	2059.9	-1.00	1539.6	0.796	1.30	-10.9	2.8	-0.03	-0.0708	0.0184	-0.0311	-3.85
1	120	3	39.36	2059.9	1.00	1537.3	0.795	1.30	15.1	2.7	0.09	0.0980	0.0177	0.0028	5.55
1	120	4	39.77	2059.9	-2.00	1530.3	0.794	1.31	-23.8	2.9	-0.13	-0.1557	0.0190	-0.0043	-8.18
1	120	5	39.30	2059.9	-3.00	1540.4	0.796	1.30	-43.1	3.0	-0.27	-0.2602	0.0198	-0.0088	-13.15
1	120	6	39.83	2059.9	-4.00	1538.9	0.795	1.33	-52.4	3.2	-0.37	-0.3412	0.0210	-0.0122	-16.28
1	110	93	0.0	3614.3	-3.00	1539.6	0.796	2.31	2.4	-0.2	0.02	-0.3502	0.0215	-0.0126	-16.27
1	120	7	39.89	3614.3	-4.00	1539.6	0.795	2.31	-53.9	3.3	-0.34	-0.2745	0.0213	-0.0099	-12.89
1	120	8	39.90	3614.3	-3.00	1540.4	0.797	2.31	-22.3	3.3	-0.31	-0.1973	0.0204	-0.0057	-9.65
1	120	9	39.92	3614.3	-2.00	1541.9	0.797	2.31	-30.4	3.1	-0.18	-0.1050	0.0197	-0.0028	-5.32
1	120	10	39.87	3614.3	-1.00	1538.0	0.796	2.31	-16.2	3.0	-0.08	-0.0144	0.0194	0.0006	-0.74
1	120	11	39.89	3614.3	0.0	1539.6	0.796	2.31	-2.2	3.0	0.02	-0.0144	0.0194	0.0006	-0.74
1	120	12	39.93	3614.3	1.00	1542.7	0.797	2.33	11.5	3.0	0.12	0.0745	0.0192	0.0038	3.87

CONSTANTS: TEMP= 73.39999 DEG F RHO= 1.93538 SLUG/CUFT
 PV= 58.66269 PSF NU= 0.10051E-04 SQFT/SEC
 MW= 62.20308 LBS/CUFT WM= 845.27783 LBS/CUFT
 LC= 0.20000 FT A= 0.10000 SQFT

RUN	CCN	CARD	VELOCITY VO,FT/SEC	PRESSURE PO,PSFA	PITCH DEG	QO PSF	RN 10 E-6	SIGMA	LIFT L,LBS	DRAG D,LBS	MOMENT M,FT-LB	CL	CD	CM	L/D
3	110	95	0.0	5670.1	-3.00	4417.8	1.343	1.27	3.1	-0.5	0.06	0.0102	0.0155	0.0001	0.66
3	120	18	67.57	5670.1	0.0	4495.5	1.355	1.25	4.5	6.9	0.01	0.0102	0.0155	0.0001	0.66
3	120	19	68.16	5670.1	1.00	4487.7	1.354	1.25	42.6	7.1	0.33	0.0948	0.0158	0.0037	6.00
3	120	20	68.10	5670.1	-1.00	4487.7	1.354	1.25	-34.7	7.1	-0.31	-0.0773	0.0159	-0.0034	-6.87
3	120	21	68.10	5670.1	-2.00	4487.7	1.354	1.25	-74.9	7.3	-0.61	-0.1668	0.0163	-0.0068	-10.24
3	120	22	67.98	5670.1	-3.00	4472.2	1.351	1.25	-113.7	7.7	-0.92	-0.2543	0.0172	-0.0103	-14.79
3	120	23	67.92	5670.1	-4.00	4464.4	1.350	1.26	-151.9	8.1	-1.20	-0.3401	0.0182	-0.0135	-18.65
3	120	24	67.98	5670.1	-3.00	4472.2	1.351	1.25	-114.5	7.8	-0.87	-0.2561	0.0174	-0.0097	-14.75
3	120	25	68.10	5670.1	-2.00	4487.7	1.354	1.25	-75.9	7.3	-0.55	-0.1692	0.0163	-0.0062	-10.35
3	120	26	67.98	5670.1	-1.00	4472.2	1.351	1.25	-36.5	7.2	-0.25	-0.0817	0.0161	-0.0028	-5.07
3	120	27	67.98	5670.1	1.00	4472.2	1.351	1.25	42.3	7.0	0.29	0.0947	0.0156	0.0032	6.08
3	120	28	67.99	5670.1	-0.18	4472.2	1.351	1.25	-2.8	6.8	-0.04	-0.0062	0.0152	-0.0005	-0.41
4	110	95	0.0	5670.1	-3.00	4417.8	1.343	1.25	3.1	-0.5	0.06	0.0102	0.0155	0.0001	0.66

THREE COMPONENT

GALCIT Report
HSWT-1137

RUN DATA CORRECTED FOR BALANCE INTERACTIONS

CONSTANTS: TEMP= 73.37999 DEG F
PV= 58.66269 PSF
WM= 62.20303 LBS/CUFT
LC= 0.20000 FT

RHO= 1.93538 SLUG/CUFT
NU= 0.10061E-34 SOFT/SEC
WM= 845.27733 LBS/CUFT
A= 0.10000 SUFT

RUN	CCN	CARD	VELOCITY VO, FT/SEC	PRESSURE PO, PSFA	PITCH DEG	QO PSF	RN 10 E-6	SIGMA	LIFT L, LBS	DRAG D, LBS	MOMENT M, FT-LB	CL	CD	CM	L/O
4	120	29	65.09	5670.1	-0.18	4099.5	1.294	1.37	-2.5	6.4	-0.07	-0.0061	0.0155	-0.0009	-0.39
4	120	30	60.35	5670.1	-0.18	3524.9	1.203	1.59	-2.5	5.6	-0.07	-0.0072	0.0160	-0.0010	-0.45
4	120	31	55.00	5670.1	-0.18	2927.1	1.093	1.92	-3.6	4.8	-0.06	-0.0124	0.0163	-0.0010	-0.76
4	120	32	50.11	5670.1	-0.18	2430.2	0.996	2.31	-3.2	4.1	-0.06	-0.0130	0.0167	-0.0012	-0.78
4	120	33	44.97	5670.1	-0.18	1936.6	0.894	2.87	-3.2	3.4	-0.05	-0.0161	0.0172	-0.0013	-0.94
4	120	34	39.96	5670.1	-0.18	1545.1	0.794	3.63	-3.5	2.8	-0.05	-0.0229	0.0179	-0.0016	-1.27
4	120	35	34.92	5670.1	-0.18	1180.2	0.694	4.75	-3.0	2.1	-0.05	-0.0255	0.0178	-0.0023	-1.43
4	120	36	29.98	5670.1	-0.18	809.6	0.596	6.45	-2.9	1.6	-0.06	-0.0336	0.0187	-0.0034	-1.79
4	120	37	25.02	5670.1	-0.18	605.6	0.497	9.27	-3.0	1.2	-0.07	-0.0498	0.0193	-0.0059	-2.58
4	120	38	19.91	5670.1	-0.18	383.6	0.356	14.63	-2.8	0.9	-0.06	-0.0737	0.0230	-0.0084	-3.20
4	120	39	67.93	5670.1	-0.18	4472.2	1.351	1.25	-2.8	7.0	-0.06	-0.0063	0.0158	-0.0007	-0.40
4	120	40	65.03	5670.1	-0.18	4091.7	1.293	1.37	-2.9	6.5	-0.07	-0.0070	0.0158	-0.0008	-0.45

CONSTANTS: TEMP= 73.89999 DEG F
PV= 59.64909 PSF
WM= 62.19826 LBS/CUFT
LC= 0.20000 FT

RHC= 1.93523 SLUG/CUFT
NU= 0.99967E-05 SOFT/SEC
WM= 845.23779 LBS/CUFT
A= 0.10000 SUFT

RUN	CCN	CARD	VELOCITY VO, FT/SEC	PRESSURE PO, PSFA	PITCH DEG	QO PSF	RN 10 E-6	SIGMA	LIFT L, LBS	DRAG D, LBS	MOMENT M, FT-LB	CL	CD	CM	L/O
5	110	42	0.0	2066.6	0.0	385.9	0.400	5.20	0.0	0.0	0.01	0.0171	0.0252	0.0007	0.68
5	120	43	19.97	2066.6	0.0	864.9	0.598	2.32	1.9	2.4	0.04	0.0223	0.0276	0.0022	0.81
5	120	44	29.90	2066.6	0.0	1177.0	0.698	1.71	2.3	3.1	0.01	0.0196	0.0266	0.0034	0.74
5	120	45	34.88	2066.6	0.0	385.1	0.399	5.21	1.8	1.1	0.03	0.0465	0.0282	0.0034	1.65
5	120	46	19.95	2066.6	1.00	383.5	0.398	5.23	3.0	1.1	0.03	0.0774	0.0278	0.0044	2.78
5	120	47	19.91	2066.6	1.00	383.5	0.398	5.23	0.1	1.1	0.01	0.0025	0.0284	0.0015	0.09
5	120	48	19.91	2066.6	-0.50	382.8	0.358	5.24	-1.1	1.1	0.00	-0.0295	0.0285	0.0005	-1.04
5	120	49	19.99	2066.6	-1.00	385.1	0.399	5.21	-2.2	1.1	-0.00	-0.0563	0.0293	-0.0005	-1.92
5	120	50	19.95	2066.6	-1.50	384.3	0.399	5.22	-3.3	1.1	-0.01	-0.0858	0.0289	-0.0015	-2.97
5	120	51	19.93	2066.6	-2.00	382.8	0.398	5.24	-5.7	1.1	-0.04	-0.1501	0.0291	-0.0052	-5.16
5	120	52	19.89	2066.6	-3.00	385.1	0.399	5.21	-8.3	1.2	-0.04	-0.2165	0.0305	-0.0054	-7.10
5	120	53	19.95	2066.6	-4.00	393.5	0.398	5.23	0.9	1.1	0.01	0.0209	0.0278	0.0007	0.75
5	120	54	19.91	2066.6	0.0	801.0	0.597	2.33	1.9	2.3	0.02	0.0224	0.0272	0.0010	0.82
5	120	55	29.83	2066.6	0.0	802.6	0.597	2.33	0.4	2.4	0.02	0.0049	0.0279	0.0011	0.18
5	120	56	29.86	2066.6	-0.50	864.9	0.598	2.32	-1.6	2.4	0.00	-0.0180	0.0274	-0.0001	-0.66
5	120	57	29.90	2066.6	-1.00	864.9	0.598	2.32	-1.6	2.4	0.00	-0.0180	0.0274	-0.0001	-0.66

THREE COMPONENT

RUN DATA CORRECTED FOR BALANCE INTERACTIONS

CONSTANTS: TEMP= 73.89999 DEG F RHO= 1.93523 SLUG/CUFT
 PV= 59.64909 PSF NU= 0.99967E-05 SQFT/SEC
 MW= 62.19826 LBS/CUFT WM= 845.23779 LBS/CUFT
 LC= 0.20000 FT A= 0.10000 SQFT

RUN	CCN	CARD	VELOCITY V3, FT/SEC	PRESSURE P0, PSFA	PITCH DEG	QO PSF	RN 10 E-6	SIGMA	LIFT L, LBS	DRAG D, LBS	MOMENT M, FT-LB	CL	CD	CM	L/D
5	120	58	29.87	2066.6	-3.00	863.3	0.598	2.32	-5.0	2.4	-0.03	-0.0584	0.0277	-0.0016	-2.11
5	120	59	29.92	2066.6	-3.00	866.4	0.599	2.32	-8.7	2.4	-0.06	-0.1000	0.0277	-0.0033	-3.62
5	120	60	29.92	2066.6	-4.00	866.4	0.599	2.32	-12.0	2.4	-0.07	-0.1386	0.0281	-0.0339	-4.92
5	120	61	29.91	2066.6	0.50	865.7	0.599	2.32	3.9	2.3	0.03	0.0452	0.0266	0.0019	1.70
5	120	62	29.94	2066.6	1.00	867.2	0.599	2.31	5.7	2.4	0.05	0.0657	0.0274	0.0027	2.39
5	120	63	29.96	2066.6	0.00	868.8	0.599	2.31	2.0	2.4	0.02	0.0233	0.0272	0.0014	0.86
5	130	64	0.00	2066.6	0.00				0.0	0.1	0.01				

CONSTANTS: TEMP= 73.70000 DEG F RHO= 1.93529 SLUG/CUFT
 PV= 59.25453 PSF NU= 0.10022E-04 SQFT/SEC
 MW= 62.20000 LBS/CUFT WM= 845.25391 LBS/CUFT
 LC= 0.20000 FT A= 0.10000 SQFT

RUN	CCN	CARD	VELOCITY V3, FT/SEC	PRESSURE P0, PSFA	PITCH DEG	QO PSF	RN 10 E-6	SIGMA	LIFT L, LBS	DRAG D, LBS	MOMENT M, FT-LB	CL	CD	CM	L/D
6	110	94	0.00	4945.6	-3.00	1530.0	0.796	3.18	2.9	-0.4	0.06	0.0006	0.0222	-0.0037	0.03
6	120	67	39.87	4945.6	0.00	1541.1	0.796	3.17	0.1	3.4	-0.11	0.0147	0.0222	-0.0028	0.66
6	120	68	39.91	4945.6	0.50	1542.7	0.797	3.17	2.3	3.4	-0.09	0.0305	0.0217	-0.0016	1.40
6	120	69	39.93	4945.6	1.00	1537.3	0.795	3.18	-1.8	3.5	-0.12	-0.0119	0.0226	-0.0040	-0.53
6	120	70	39.36	4945.6	-0.50	1539.6	0.796	3.17	-4.7	3.5	-0.17	-0.0303	0.0229	-0.0056	-1.32
7	110	94	0.00	4945.6	-3.00	1535.7	0.795	3.18	2.9	-0.4	0.06	-0.0301	0.0221	-0.0043	-1.36
7	120	74	39.84	4945.6	-1.00	1538.0	0.796	3.18	-4.6	3.4	-0.13	-0.0576	0.0217	-0.0057	-2.65
7	120	75	39.87	4945.6	-2.00	1535.7	0.795	3.18	-8.9	3.3	-0.17	-0.0856	0.0221	-0.0071	-3.87
7	120	76	39.84	4945.6	-3.00	1538.8	0.796	3.18	-13.1	3.4	-0.22	-0.1102	0.0226	-0.0380	-4.87
7	120	77	39.88	4945.6	-4.00	1538.8	0.796	3.18	-17.0	3.5	-0.25	-0.1102	0.0226	-0.0380	-4.87
7	120	78	39.88	4945.6	1.00	1538.8	0.796	3.18	4.2	3.3	-0.05	0.0272	0.0216	-0.0016	1.26
7	120	79	39.89	4945.6	0.00	1539.6	0.796	3.17	0.0	3.3	-0.10	-0.0021	0.0212	-0.0033	-0.10
8	110	95	0.00	5664.9	-3.00	2397.5	0.993	2.34	3.1	-0.5	0.06	-0.0055	0.0201	-0.0034	-0.27
8	120	82	49.78	5664.9	0.00	2395.2	0.993	2.34	-1.3	4.8	-0.12	0.0063	0.0207	-0.0024	0.30
8	120	83	49.75	5664.9	0.50	2394.4	0.993	2.34	1.5	5.0	-0.16	0.0173	0.0206	-0.0015	0.84
8	120	84	49.74	5664.9	1.00	2394.4	0.993	2.34	4.1	4.9	-0.07	0.0157	0.0206	-0.0038	-0.76
8	120	85	49.74	5664.9	-0.50	2396.7	0.993	2.34	-3.8	4.9	-0.18	-0.0206	0.0206	-0.0045	-1.30
8	120	86	49.77	5664.9	-1.00	2396.0	0.993	2.34	-6.4	4.9	-0.22	-0.0267	0.0207	-0.0063	-2.31
8	120	87	49.76	5664.9	-2.00	2396.0	0.993	2.34	-11.4	5.0	-0.30	-0.0478	0.0207	-0.0083	-3.20
8	120	88	49.76	5664.9	-3.00	2396.0	0.993	2.34	-16.0	5.0	-0.36	-0.0666	0.0208	-0.0075	-4.10

THREE COMPONENT
RUN DATA CORRECTED FOR BALANCE INTERACTIONS

CONSTANTS: TEMP= 75.00000 DEG F RHO= 1.93520 SLUG/CUFT
 PV= 59.84639 PSF MU= 0.99839E-05 SQFT/SEC
 WM= 62.19731 LBS/CUFT NM= 845.22998 LBS/CUFT
 LC= 0.20000 FT A= 0.10000 SQFT

RUN	CCN	CARD	VELOCITY V,F/SEC	PRESSURE P,PSFA	PITCH DEG	QO PSF	RN 10 E-6	SIGMA	LIFT L,LBS	DZAG D,LBS	MOMENT M,FT-LB	CL	CD	CM	L/D
9	110	95	0.0	5669.8	-3.00	2394.3	0.996	2.34	3.1	-0.5	0.06	-0.0502	0.0220	-0.0036	-2.28
9	120	91	49.74	5664.7	-3.00				-12.0	5.3	-0.17				
11	110	95	0.0	5659.8	-3.00				3.1	-0.5	0.06				
11	120	99	10.25	5664.7	1.00	102.5	0.206	54.69	1.3	0.3	-0.01	0.1241	0.0297	-0.0064	4.18
11	120	100	19.91	5664.7	1.00	383.5	0.399	14.61	2.9	0.9	-0.02	0.0761	0.0233	-0.0026	3.27
11	120	101	29.87	5654.7	1.00	863.3	0.598	6.49	4.1	1.9	-0.01	0.0480	0.0221	-0.0004	2.18
11	120	102	39.84	5664.7	1.00	1535.7	0.798	3.65	5.5	3.3	0.03	0.0359	0.0215	0.0010	1.67
11	120	103	49.74	5664.7	1.00	2393.6	0.996	2.34	8.7	5.2	0.12	0.0382	0.0216	0.0026	1.68
11	120	104	59.81	5664.7	1.00	3461.1	1.198	1.62	11.3	7.6	0.18	0.0328	0.0219	0.0025	1.50
11	120	105	49.75	5664.7	1.00	2395.1	0.597	2.34	8.7	5.2	0.12	0.0364	0.0217	0.0025	1.67
11	120	106	39.80	5664.7	1.00	1532.6	0.797	3.65	5.7	3.4	0.06	0.0375	0.0225	0.0019	1.67
11	120	107	29.80	5664.7	1.00	859.4	0.597	6.52	3.9	2.1	0.01	0.0455	0.0239	0.0003	1.90
11	120	108	19.95	5664.7	1.00	385.1	0.400	14.56	2.6	1.1	-0.01	0.0673	0.0277	-0.0018	2.43
11	120	109	10.29	5664.7	1.00	102.5	0.206	54.69	1.3	0.4	-0.01	0.0965	0.0427	-0.0033	2.26
11	130	110	0.0	5664.7	1.00				3.1	-0.5	0.06				
12	110	112	0.0	5664.7	0.0				3.1	-0.5	0.06				
12	120	113	9.93	5654.7	0.0	95.5	0.199	58.69	0.4	0.2	-0.01	0.0444	0.0259	-0.0036	1.71
12	120	114	19.99	5664.7	0.0	386.6	0.400	14.50	0.5	0.9	-0.02	0.0134	0.0232	-0.0028	0.58
12	120	115	29.94	5664.7	0.0	867.2	0.600	6.45	0.5	1.9	-0.02	0.0054	0.0220	-0.0010	0.25
12	120	116	39.85	5654.7	0.0	1536.4	0.798	3.65	1.3	3.3	0.01	0.0086	0.0212	0.0005	0.40
12	120	117	49.78	5664.7	0.0	2397.4	0.997	2.34	3.6	5.0	0.07	0.0149	0.0209	0.0015	0.71
12	120	118	59.79	5664.7	0.0	3459.5	1.198	1.62	5.1	7.4	0.06	0.0147	0.0214	0.0009	0.69
12	120	119	49.80	5664.7	0.0	2399.8	0.598	2.34	3.6	5.2	0.07	0.0149	0.0218	0.0014	0.68
12	120	120	39.82	5664.7	0.0	1534.1	0.798	3.65	1.3	3.4	0.01	0.0086	0.0221	0.0003	0.39
12	120	121	29.84	5664.7	0.0	861.8	0.598	6.50	0.5	2.0	-0.02	0.0055	0.0232	-0.0010	0.24
12	120	122	19.71	5664.7	0.0	375.8	0.395	14.92	0.4	1.0	-0.02	0.0103	0.0274	-0.0029	0.37
12	120	123	10.01	5664.7	0.0	97.0	0.201	57.75	0.3	0.4	-0.01	0.0340	0.0432	-0.0037	0.79
12	130	124	0.0	5664.7	0.0				3.0	-0.3	0.06				
13	110	125	0.0	5664.7	-1.00				3.1	-0.5	0.06				
13	120	126	10.13	5664.7	-1.00	99.4	0.203	56.40	-0.3	0.3	-0.02	-0.0332	0.0270	-0.0105	-1.23
13	120	127	19.95	5664.7	-1.00	385.1	0.400	14.56	-1.7	0.9	-0.05	-0.0440	0.0234	-0.0065	-1.86
13	120	128	29.83	5664.7	-1.00	861.0	0.598	6.51	-3.0	1.9	-0.05	-0.0350	0.0218	-0.0031	-1.61
13	120	129	39.84	5654.7	-1.00	1535.7	0.798	3.65	-3.2	3.3	-0.04	-0.0205	0.0215	-0.0014	-0.95
13	120	130	49.74	5664.7	-1.00	2394.3	0.996	2.34	-1.6	5.1	-0.02	-0.0059	0.0214	-0.0004	-0.32
13	120	131	59.80	5664.7	-1.00	3460.3	1.198	1.62	-1.1	7.7	-0.06	-0.0033	0.0222	-0.0009	-0.15
13	120	132	49.80	5664.7	-1.00	2399.8	0.598	2.34	-1.7	5.3	-0.03	-0.0073	0.0220	-0.0007	-0.33
13	120	133	39.84	5664.7	-1.00	1535.7	0.798	3.65	-3.0	3.5	-0.04	-0.0166	0.0226	-0.0014	-0.87
13	120	134	29.84	5664.7	-1.00	861.6	0.598	6.50	-2.9	2.1	-0.05	-0.0333	0.0244	-0.0031	-1.37

THREE COMPONENT
RUN DATA CORRECTED FOR BALANCE INTERACTIONS

CONSTANTS: TEMP= 74.0000J DEG F RHO= 1.93520 SLUG/CUFT
 PV= 59.84639 PSF NU= 0.99839E-05 SOFT/SEC
 WM= 62.19731 LBS/CUFT MM= 845.22998 LBS/CUFT
 LC= 0.20000 FT A= 0.10000 SOFT

RUN	CCV	CARD	VELOCITY VO, FT/SEC	PRESSURE PO, PSFA	PITCH DEG	QO PSF	RN 10 E-6	SIGMA	LIFT L, LBS	DRAG D, LBS	MOMENT M, FT-LB	CL	CD	CM	L/D
13	120	135	19.95	5664.7	-1.00	385.1	0.400	14.56	-1.7	1.1	-0.05	-0.0452	0.0288	-0.0065	-1.57
13	120	136	9.93	5664.7	-1.00	95.5	0.199	58.69	-0.3	0.4	-0.02	-0.0345	0.0441	-0.0111	-0.78
13	120	137	0.0	5664.7	-1.00				3.1	-0.4	0.06				
14	120	138	0.0	5664.7	-2.00				3.1	-0.5	0.06				
14	120	139	10.01	5654.7	-2.00	97.0	0.201	57.75	-1.0	0.3	-0.03	-0.1019	0.0277	-0.0145	-3.68
14	120	140	19.93	5654.7	-2.00	384.3	0.399	14.59	-3.9	0.9	-0.07	-0.1017	0.0235	-0.0085	-4.33
14	120	141	29.87	5664.7	-2.00	863.0	0.598	6.59	-6.4	1.9	-0.08	-0.0742	0.0222	-0.0044	-3.34
14	120	142	39.80	5664.7	-2.00	1532.6	0.797	3.66	-7.3	3.3	-0.09	-0.0473	0.0214	-0.0028	-2.22
14	120	143	49.80	5664.7	-2.00	2399.8	0.998	2.34	-6.7	5.1	-0.10	-0.0281	0.0211	-0.0020	-1.33
14	120	144	59.83	5664.7	-2.00	3464.2	1.199	1.62	-7.2	7.4	-0.16	-0.0207	0.0214	-0.0026	-0.97
14	120	145	49.81	5664.7	-2.00	2400.6	0.998	2.33	-6.9	5.1	-0.11	-0.0286	0.0214	-0.0023	-1.34
14	120	146	39.85	5654.7	-2.00	1536.4	0.798	3.65	-7.1	3.4	-0.10	-0.0463	0.0224	-0.0032	-2.09
14	120	147	29.78	5664.7	-2.00	857.9	0.598	6.53	-6.1	2.0	-0.08	-0.0708	0.0237	-0.0048	-2.99
14	120	148	19.87	5654.7	-2.00	382.0	0.398	14.67	-3.7	1.0	-0.07	-0.0974	0.0271	-0.0085	-3.59
14	120	149	10.05	5664.7	-2.00	97.8	0.201	57.30	-0.9	0.4	-0.03	-0.0963	0.0373	-0.0144	-2.58
14	120	150	0.0	5664.7	-2.00				3.1	-0.4	0.06				
15	120	151	0.0	5664.7	-3.00				3.1	-0.5	0.06				
15	120	152	10.09	5664.7	-3.00	98.6	0.202	56.84	-1.8	0.3	-0.03	-0.1815	0.0274	-0.0146	-6.63
15	120	153	19.89	5664.7	-3.00	382.8	0.398	14.64	-6.0	0.9	-0.07	-0.1575	0.0242	-0.0087	-6.52
15	120	154	29.83	5654.7	-3.00	861.0	0.598	6.51	-9.7	1.9	-0.09	-0.1127	0.0225	-0.0353	-5.00
15	120	155	39.91	5664.7	-3.00	1541.1	0.799	3.64	-11.5	3.4	-0.12	-0.0749	0.0220	-0.0338	-3.40
15	120	156	49.81	5604.7	-3.00	2400.6	0.999	2.33	-12.0	5.2	-0.17	-0.0498	0.0215	-0.0035	-2.32
15	120	157	59.81	5664.7	-3.00	3461.9	1.198	1.62	-13.7	7.8	-0.31	-0.0396	0.0225	-0.0044	-1.76
15	120	158	49.78	5664.7	-3.00	2397.4	0.997	2.34	-12.2	5.3	-0.19	-0.0509	0.0222	-0.0040	-2.29
15	120	159	39.81	5664.7	-3.00	1533.3	0.797	3.65	-11.3	3.4	-0.14	-0.0737	0.0224	-0.0044	-3.29
15	120	160	29.87	5654.7	-3.00	863.3	0.598	6.59	-9.5	2.1	-0.10	-0.1096	0.0238	-0.0361	-4.61
15	120	161	20.01	5664.7	-3.00	387.4	0.401	14.67	-6.1	1.1	-0.07	-0.1568	0.0278	-0.0395	-5.64
15	120	162	10.13	5654.7	-3.00	99.4	0.203	56.83	-1.9	0.4	-0.03	-0.1896	0.0445	-0.0146	-4.26
15	120	163	0.0	5664.7	-3.00				3.1	-0.3	0.06				
16	120	164	0.0	5664.7	-4.00				3.1	-0.5	0.07				
16	120	165	10.13	5664.7	-4.00	99.4	0.203	56.83	-2.5	0.3	-0.04	-0.2512	0.0292	-0.0181	-8.61
16	120	166	19.87	5664.7	-4.00	382.0	0.398	14.67	-8.1	0.9	-0.09	-0.2121	0.0248	-0.0116	-8.56
16	120	167	29.83	5604.7	-4.00	861.0	0.598	6.51	-13.0	2.0	-0.12	-0.1510	0.0228	-0.0070	-6.62
16	120	168	39.90	5664.7	-4.00	1540.3	0.799	3.64	-15.6	3.5	-0.17	-0.1012	0.0227	-0.0354	-4.46
16	120	169	49.79	5664.7	-4.00	2399.0	0.997	2.34	-16.9	5.3	-0.25	-0.0703	0.0223	-0.0052	-3.15
16	120	170	59.80	5664.7	-4.00	3460.3	1.198	1.62	-19.3	7.8	-0.42	-0.0557	0.0224	-0.0360	-2.48
16	120	171	49.80	5664.7	-4.00	2399.8	0.998	2.34	-17.0	5.5	-0.27	-0.0708	0.0228	-0.0357	-3.11
16	120	172	39.85	5664.7	-4.00	1536.4	0.799	3.65	-15.4	3.6	-0.19	-0.1002	0.0231	-0.0061	-4.33
16	120	173	29.84	5664.7	-4.00	861.8	0.598	6.53	-12.5	2.1	-0.13	-0.1448	0.0241	-0.0078	-6.00

PAGE

GALCIT REPORT
HSWT-1137

THREE COMPONENT

RUN DATA CORRECTED FOR BALANCE INTERACTIONS

CONSTANTS: TEMP= 74.00000 DEG F RHO= 1.93520 SLUG/CUFT
 PV= 59.85639 PSF MU= 0.99839E-05 SOFT/SEC
 WM= 62.19731 LBS/CUFT A= 845.22998 LBS/CUFT
 LC= 0.20000 FT A= 0.10000 SOFT

RUN	CCN	CARD	VELOCITY VO, FT/SEC	PRESSURE PO, PSFA	PITCH DEG	QO PSF	RN 10 E-6	SIGMA	LIFT L, LBS	DRAG D, LBS	MOMENT M, FT-LB	CL	CD	CM	L/D
15	120	174	19.99	5664.7	-4.00	386.6	0.400	14.50	-7.9	1.1	-0.10	-0.2046	0.0284	-0.0123	-7.20
16	120	175	10.01	5664.7	-4.00	97.0	0.201	57.75	-2.5	0.4	-0.04	-0.2572	0.0437	-0.0221	-5.89
16	130	176	0.0	5664.7	-4.00				3.1	-0.3	0.06				
17	110	177	0.0	5654.7	-4.00				3.0	-0.4	0.07				
17	120	178	49.81	5664.7	-4.00	2400.6	0.998	2.33	-17.0	5.3	-0.26	-0.0706	0.0219	-0.0054	-3.23
17	120	179	49.84	5654.7	-0.60	2403.7	0.998	2.33	0.2	4.9	-0.03	0.0008	0.0206	-0.0006	0.04
17	130	180	0.0	5664.7	-0.60				3.0	-0.4	0.06				

CONSTANTS: TEMP= 74.99999 DEG F RHO= 1.93508 SLUG/CUFT
 PV= 61.07324 PSF MU= 0.99073E-05 SOFT/SEC
 WM= 62.19345 LBS/CUFT A= 845.18188 LBS/CUFT
 LC= 0.20000 FT A= 0.10000 SOFT

RUN	CCN	CARD	VELOCITY VO, FT/SEC	PRESSURE PO, PSFA	PITCH DEG	QO PSF	RN 10 E-6	SIGMA	LIFT L, LBS	DRAG D, LBS	MOMENT M, FT-LB	CL	CD	CM	L/D
18	110	181	0.0	5636.5	-4.00				0.5	-0.6	-0.05				
18	120	182	10.09	5636.5	-4.00	98.6	0.204	56.55	-2.4	0.3	-0.04	-0.2484	0.0275	-0.0182	-9.04
18	120	183	19.91	5636.5	-4.00	383.5	0.402	14.54	-8.1	0.9	-0.09	-0.2112	0.0247	-0.0115	-8.56
18	120	184	29.83	5636.5	-4.00	861.0	0.602	6.68	-13.0	2.0	-0.13	-0.1504	0.0228	-0.0078	-6.59
18	120	185	39.75	5636.5	-4.00	1535.6	0.804	3.63	-15.6	3.4	-0.18	-0.1018	0.0220	-0.0058	-4.62
18	120	186	49.78	5636.5	-4.00	2397.3	1.005	2.33	-17.1	5.2	-0.26	-0.0713	0.0218	-0.0054	-3.28
18	120	187	59.81	5636.5	-4.00	3400.9	1.207	1.61	-19.4	7.7	-0.42	-0.0561	0.0224	-0.0060	-2.51
18	120	188	49.77	5636.5	-4.00	2396.5	1.005	2.33	-17.2	5.4	-0.27	-0.0717	0.0226	-0.0057	-3.18
18	120	189	19.93	5636.5	-4.00	384.3	0.402	14.51	-7.8	1.1	-0.10	-0.2034	0.0276	-0.0124	-7.37
18	130	190	0.0	5636.5	-4.00				0.3	-0.5	-0.06				
19	110	191	0.0	5636.5	1.00				0.4	-0.6	-0.06				
19	120	192	10.09	5636.5	1.00	98.6	0.204	56.55	1.2	0.3	0.00	0.1194	0.0328	0.0001	3.64
19	120	193	19.95	5636.5	1.00	395.1	0.403	14.48	3.1	1.3	-0.01	0.0807	0.0326	-0.0009	2.47
19	120	194	29.82	5636.5	1.00	860.2	0.602	6.48	4.3	3.1	-0.00	0.0498	0.0359	-0.0002	1.39
19	120	195	39.83	5636.5	1.00	1534.8	0.804	3.63	5.7	5.8	0.03	0.0374	0.0378	0.0011	0.99
19	130	196	0.0	5636.5	1.00				0.4	-0.4	-0.06				

TABLE III

Measured Deflections on Rubber Model

Data Pt.	α, Deg.	Vel.* ft/sec.	Y Elevation, in.		Data Pt.	α, Deg.	Vel.* ft/sec.	Y Elevation, in.	
								Nose	T. E.
98	+1	0	1.577	Nose	125	-1	0	1.595	--
99	"	10	1.573	"	126	"	10	1.600	1.588
100	"	20	1.557	"	127	"	20	1.609	1.587
101	"	30	1.549	"	128	"	30	1.616	1.595
102	"	40	1.545	"	129	"	40	1.619	1.600
103	"	50	1.533	"	130	"	50	1.622	1.591
104	"	60	1.522	"	131	"	60	1.623	1.591
"	"	"	1.522	T. E.	132	"	50	1.625	1.591
105	"	50	1.530	"	133	"	40	1.621	1.592
106	"	40	1.561	"	134	"	30	1.619	1.594
107	"	30	1.580	"	135	"	20	1.609	1.589
108	"	20	1.600	"	136	"	10	1.605	1.575
109	"	10	1.622	"	137	"	0	1.603	1.584
110	"	0	1.641	"	138	-2	0	1.610	1.548
112	0	0	1.611	"	139	"	10	1.615	1.549
113	"	10	1.603	"	140	"	20	1.634	1.580
114	"	20	1.595	"	141	"	30	1.646	1.599
115	"	30	1.598	"	142	"	40	1.654	1.614
116	"	40	1.587	"	143	"	50	1.666	1.615
117	"	50	1.561	"	144	"	60	1.670	1.631
118	"	60	1.559	"	145	"	50	1.666	1.610
"	"	"	1.569	Nose	146	"	40	1.655	1.616
119	"	50	1.577	"	147	"	30	1.651	1.605
120	"	40	1.581	"	148	"	20	1.636	1.582
121	"	30	1.586	"	149	"	10	1.618	1.554
122	"	20	1.586	"	150	"	0	1.608	1.550
123	"	10	1.586	"					
124	"	0	1.589	"					

*Nominal Velocity

TABLE III (Cont'd.)

Measured Deflections on Rubber Model

Data Pt.	α , Deg.	Vel.,* ft/sec.	Y Elevation, in.	
			Nose	T. E.
151	-3	0	1.620	1.518
152	"	10	1.632	1.530
153	"	20	1.658	1.573
154	"	30	1.679	1.613
155	"	40	1.694	1.625
156	"	50	1.710	1.644
157	"	60	1.721	1.656
158	"	50	1.710	1.646
159	"	40	1.698	1.633
160	"	30	1.682	1.615
161	"	20	1.662	1.580
162	"	10	1.637	1.535
163	"	0	1.623	1.520

*Nominal Velocity

NSRDC FAIRED TOWLINE TESTS
IN THE HIGH SPEED WATER TUNNEL

Discussion

This report presents the results of water tunnel tests conducted on two full-scale models of a segment of the NSRDC towline (NACA 0020 airfoil profile). The primary function was to measure lift, drag and pitching moment and trailing edge deflections as a function of pitch angle on a partially elastic model. Tests were also conducted on an aluminum version model of the towline segment to serve as a data base for comparison.

These tests were conducted in the two-dimensional working section of the High Speed Water Tunnel (HSWT) in the GALCIT Hydrodynamics Laboratory*. This tunnel, which uses a closed circuit, has a choice of either a two-dimensional (6" x 30") or axi-symmetric (14" D.) working section (see Fig. 1).

Of the two models (NACA 0020 airfoil profile) used for these tests, one was fabricated from silicone rubber bonded to an epoxy bound glass fiber strength member and covered with a silicone rubber impregnated fabric (see Fig. 3, also lower model in Fig. 4). The other model of the towline segment was fabricated from aluminum. (See Fig. 4, mounted model.) The models had a span of 6 inches with a chord length of 2.4 inches.

Models were supported on the three component strain gage balance which is mounted on the side wall of the working section (see Fig. 2).

*For a more complete description of this laboratory see: Ward, T. M. "The Hydrodynamics Laboratory at the California Institute of Technology 1976", J. Fluids Engineering, ASME, December 1976.

The opposite sidewall consists of a 1.75 inch thick aluminum plate with a 7.5 inch diameter circular plexiglas viewing window. Tip clearance between the model and the viewing window was set at 0.009 inches.

Data recorded during these tests include three component force and moment data which are recorded simultaneously for each data point on IBM punched cards using an automatic data acquisition system. These data are reduced to the final coefficient forms defined in Table I. Deflections of the elastic model were also measured by means of a two directional cathetometer mounted at the viewing port. Leading and trailing edge deflection data, measured at the free end of the model, are presented in Table III commencing with data point number 98.

Data Reduction and Accuracy

Signals from the force balance, manometer readings, model settings, physical constants, and other data were recorded on punched cards and reduced using digital computer processing techniques. These data are presented in Table II. Data for run numbers 1 through 4 correspond to the aluminum model and those from runs 5 through 19 correspond to the silicone rubber model.

Manometer indications of velocity in the working section exhibit a natural oscillation which has a maximum amplitude change varying from approximately $\pm 5\%$ at 10 ft/sec to $\pm 1\%$ at 60 ft/sec. The oscillation is slow and exhibits periods when no fluctuation is detectable. Data are recorded during these periods of zero fluctuations and it is believed that the velocity data presented here are accurate to within $\pm 0.5\%$.

Working section pressure indicators exhibit similar oscillations, however, the maximum excursions are not as large and the data presented here are also believed to be accurate to within $\pm 0.5\%$.

Angle of attack settings are accurate to within ± 0.1 degree. No allowances or corrections have been made to adjust for model deflections due to applied loads, mounting plate tare or tunnel boundary effects.

The output of all balance gages, including hysteresis, nonlinearity and repeatability are linear to within $\pm 0.25\%$ of full range. The data system used to process and record the output is accurate to within $\pm 0.1\%$ of the indicated value. As a result of the above, the force and moment data presented are believed to be accurate to within the following limits:

Lift force;	± 0.5 lbs.
Drag force,	± 0.2 lbs.
Pitching moment;	± 0.75 lb. -in.

This work was performed for the U. S. Navy under Contract No. N00014-78-C-0790.

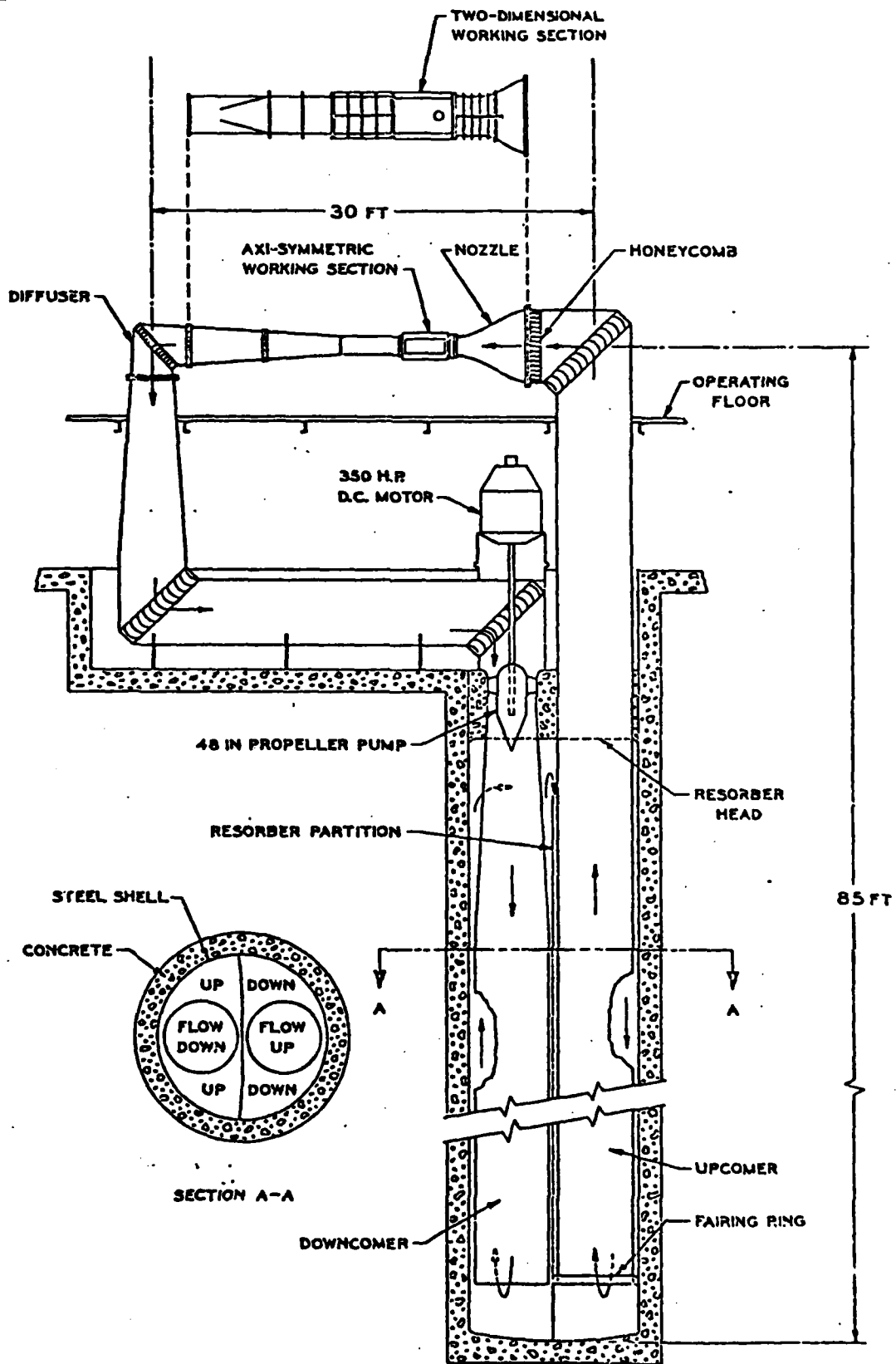

High Speed Water Tunnel Circuit Schematic

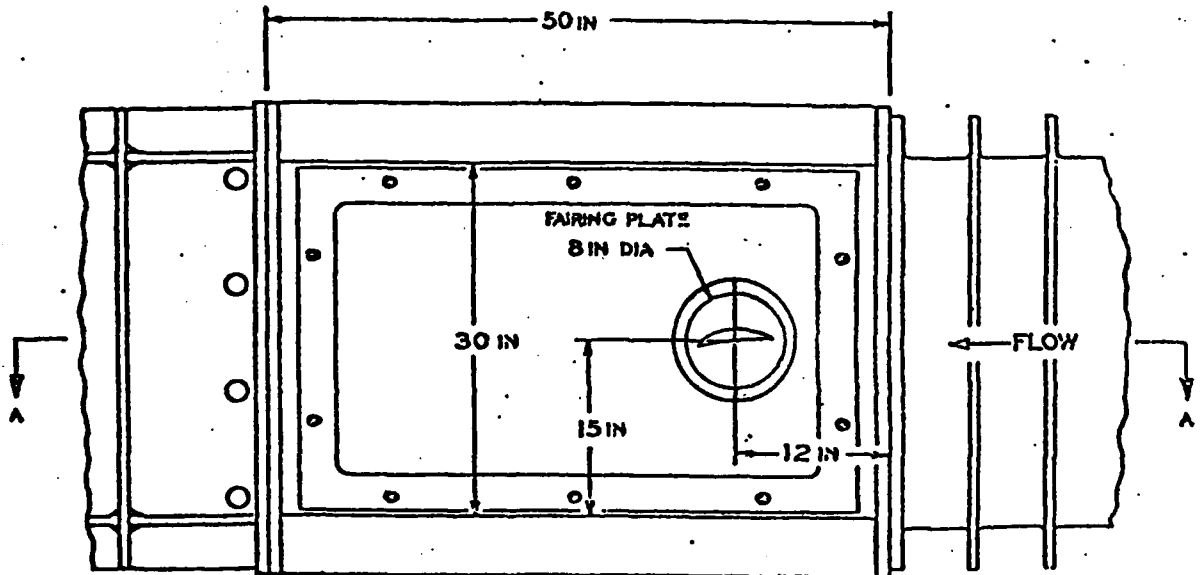
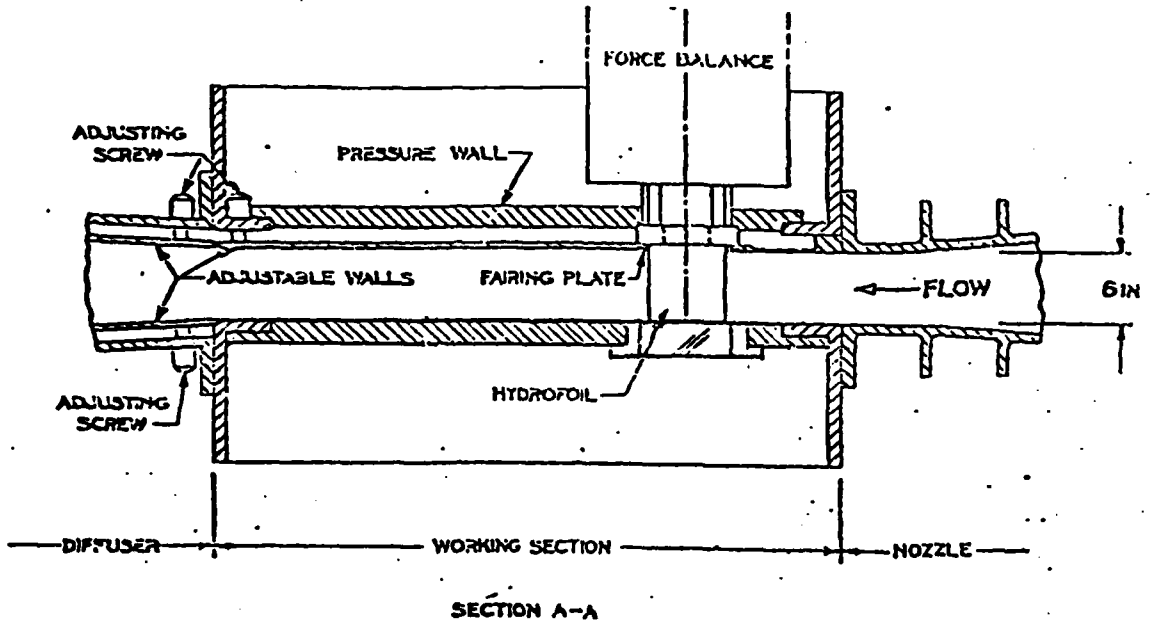

FLEXGLAS WINDOWS TOP AND BOTTOM
Two-Dimensional Working Section Schematic

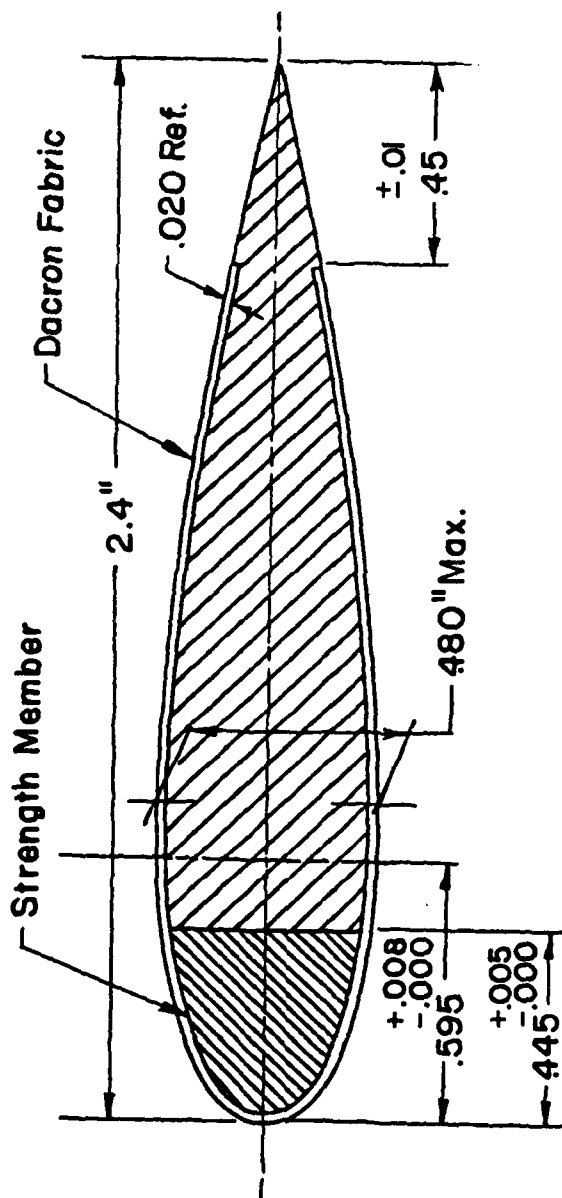

Cross-Section of Flexible Model

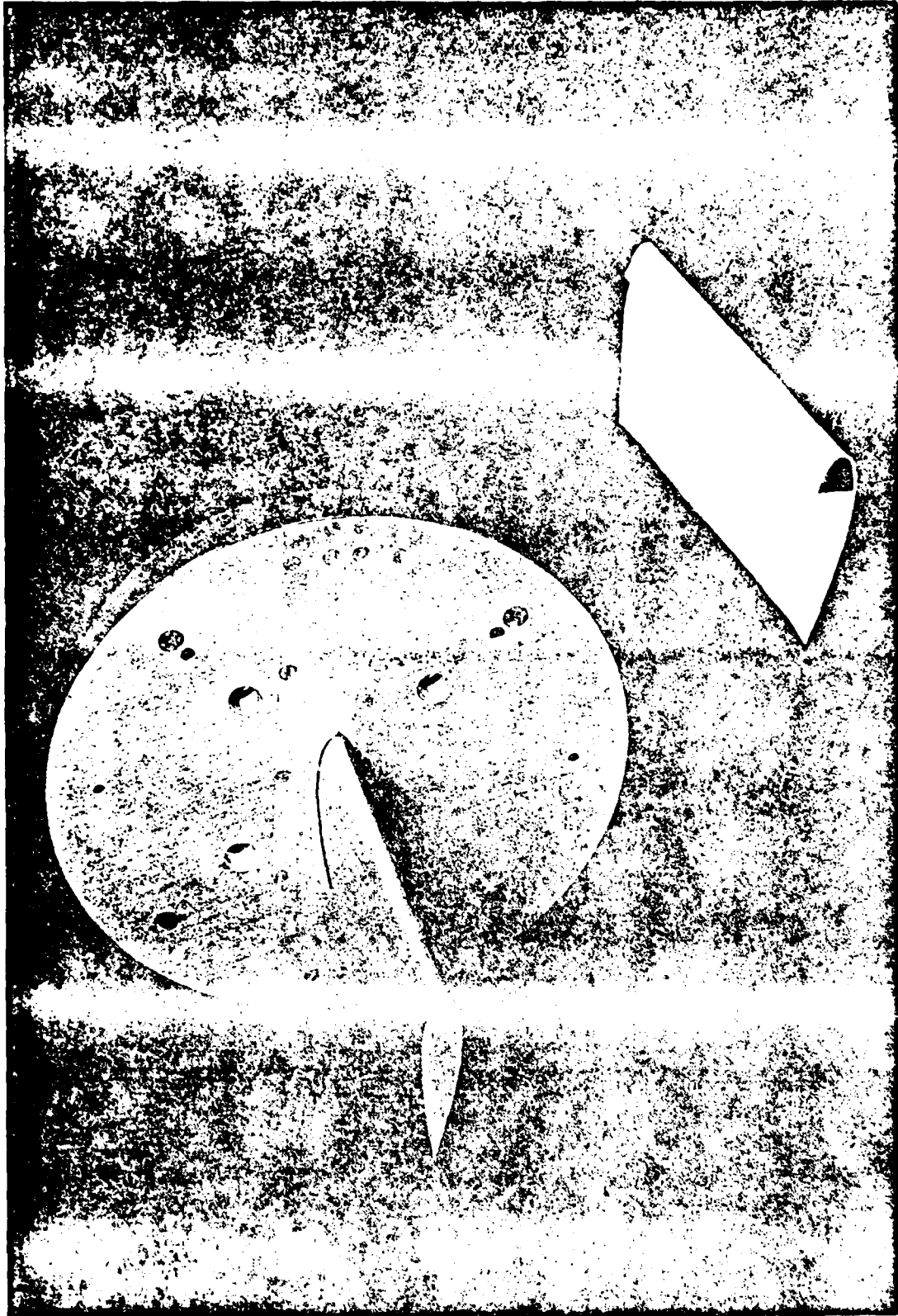

THIS PAGE IS FROM THE GALCIT REPORT
FROM GALCIT REPORT NUMBER 1137

Models of Segment of
NSRDC Faired Towline