

LEVEL #

2 CB

A082957 VOL II-D

AGARD-AR-147-VOL. IIA

AGARD-AR-147-VOL. IIA

# AGARD

ADVISORY GROUP FOR AEROSPACE RESEARCH & DEVELOPMENT

7 RUE ANCELLE 92200 NEUILLY SUR SEINE FRANCE

ADA 083314

**AGARD ADVISORY REPORT No. 147**

## The Impact of Global Positioning System on Guidance and Controls Systems Design of Military Aircraft

**Volume IIA**

**Specific Application Study No.1: Close Air Support**

**DISTRIBUTION STATEMENT A**  
Approved for public release  
Distribution Unlimited

**DTIC**  
**ELECT**  
**S** APR 22 1980 **D**

NORTH ATLANTIC TREATY ORGANIZATION



**DISTRIBUTION AND AVAILABILITY  
ON BACK COVER**

**80 4 22 009**

FILE COPY.

**Best  
Available  
Copy**

NORTH ATLANTIC TREATY ORGANIZATION  
ADVISORY GROUP FOR AEROSPACE RESEARCH AND DEVELOPMENT  
(ORGANISATION DU TRAITE DE L'ATLANTIQUE NORD)

AGARD Advisory Report No. 147

Report from the Guidance and Control Panel Working Group 04

on

THE IMPACT OF GLOBAL POSITIONING SYSTEM ON  
GUIDANCE AND CONTROLS SYSTEMS DESIGN OF MILITARY AIRCRAFT

VOLUME IIA

SPECIFIC STUDY No. 1 - APPLICATION OF THE NAVSTAR/GLOBAL POSITIONING  
SYSTEM TO THE CLOSE AIR SUPPORT MISSION - A CASE STUDY

Edited by

L.J. Urban

Technical Director  
Deputy for Avionics Control (AX)  
Aeronautical Systems Division  
Wright-Patterson Air Force Base  
Dayton, Ohio 45433  
USA

The report consists of one main document (Vol.I) and four appendices published separately  
(Volumes IIA, B, C and D).

400001

## THE MISSION OF AGARD

The mission of AGARD is to bring together the leading personalities of the NATO nations in the fields of science and technology relating to aerospace for the following purposes:

- Exchanging of scientific and technical information;
- Continuously stimulating advances in the aerospace sciences relevant to strengthening the common defence posture;
- Improving the co-operation among member nations in aerospace research and development;
- Providing scientific and technical advice and assistance to the North Atlantic Military Committee in the field of aerospace research and development;
- Rendering scientific and technical assistance, as requested, to other NATO bodies and to member nations in connection with research and development problems in the aerospace field;
- Providing assistance to member nations for the purpose of increasing their scientific and technical potential;
- Recommending effective ways for the member nations to use their research and development capabilities for the common benefit of the NATO community.

The highest authority within AGARD is the National Delegates Board consisting of officially appointed senior representatives from each member nation. The mission of AGARD is carried out through the Panels which are composed of experts appointed by the National Delegates, the Consultant and Exchange Programme and the Aerospace Applications Studies Programme. The results of AGARD work are reported to the member nations and the NATO Authorities through the AGARD series of publications of which this is one.

Participation in AGARD activities is by invitation only and is normally limited to citizens of the NATO nations.

The content of this publication has been reproduced directly from material supplied by AGARD or the author.

Published February 1980

Copyright © AGARD 1980  
All Rights Reserved

ISBN 92-835-1349-5



*Printed by Technical Editing and Reproduction Ltd  
Harford House, 7-9 Charlotte St, London W1P 1HD*



TABLE OF CONTENTS

<u>Section</u>	<u>Page</u>
Chapter I - Description of a Close Air Support Mission	1
Introduction	1
Chapter II - ARN-101 System Description	2
F-4E Avionics System Description	2
Navigation	2
Steering	3
Automatic Flight Control System Coupling	4
Approach-To-Landing	4
Interactive Control-Display	4
Data Freeze	4
Sensor Cueing/Offset Targeting	4
Weapon Delivery	4
Chapter III - Integrated NAVSTAR/GPS Digital Avionics System	5
NAVSTAR/GPS Receiver	5
Standard (F <sup>3</sup> ) Inertial Navigation Set	6
NAVSTAR/GPS - INS Kalman Filter	6
Controls and Displays	7
Weapon Delivery	7
Chapter IV - Navigation/Weapon Delivery Performance Simulation	8
Simulation Description	8
Simulation Conditions	11
Simulation Results	13
Chapter V - Conclusions and Recommendations	28
Appendix A - Draft Specification for an Integrated NAVSTAR/GPS Digital Avionics System	A-1
Appendix B - Kalman Filter Implemented	B-1
List of References	C-1

LIST OF FIGURES

<u>Figure</u>		<u>Page</u>
1	AN/ARN-101 Digital Modular Avionics System	2
2	F-4E ARN-101 System Diagram	3
3	Integrated NAVSTAR/GPS Digital Avionics System Architecture	5
4	Integrated GPS/Inertial Simulation	8
5	Kalman Filter Equations/Solution Sequence	11
6	Aircraft Flight Profile and Ground Track GPS/Inertial Kalman Filter Simulation	12
7-39	GPS/Inertial Kalman Filter Simulations	13-24

LIST OF TABLES

<u>Table</u>		<u>Page</u>
1	INS Error Sources	9
2	GPS System and Receiver Error Budget	10
3	Blind Weapon Delivery Performance Straight and Level at 5000 Feet Altitude	25
4	Blind Weapon Delivery Performance with a 30° Dive at 5000 Feet Altitude	25
5	Blind Weapon Delivery Performance Straight and Level at 10,000 Feet Altitude	26
6	Blind Weapon Delivery Performance with a 45° Dive at 10,000 Feet Altitude	26
7	Visual Weapon Delivery Performance with INS Velocity	27

APPLICATION OF THE NAVSTAR/GLOBAL POSITIONING SYSTEM (GPS) TO THE  
CLOSE AIR SUPPORT MISSION - A Case Study

CHAPTER I - Description of a Close Air Support Mission

INTRODUCTION

The Close Air Support mission involves air action against targets in proximity to friendly forces and requires integration of each air mission with the movement of those forces. Tactical air forces are applied against targets of immediate concern to surface forces when surface forces cannot produce the desired effect or when disposition of targets prevents successful attack by surface weapons. The Close Air Support aircraft may be used to provide escort and suppressive fires for airmobile and airborne forces, and to conduct surveillance and provide security for landing forces, patrols, and probing operations. The task of Close Air Support is to provide firepower, when and where needed in support of ground forces. Thus, Close Air Support must be available, responsive, integrated, and controlled.

In terms of integration, Close Air Support missions must be integrated with the fire of land forces to achieve mutual support. Close Air Support missions must also be closely integrated with the movement of land forces to insure air support is provided when and where required and to preclude inadvertent strikes against friendly forces. A means must be provided which will allow tactical air and land firepower to be integrated and thus satisfy support requirements as they occur.

Target identification and control is often assisted by a Forward Air Controller (FAC), who insures coordination with the surface units being supported. Under conditions of reduced visibility, an air surveillance radar may sometimes be employed to assist in final mission control.

Ideally, tactical strike aircraft should possess the operational capability and versatile weapon systems needed to fulfill all Close Air Support requirements, with the ability to strike either hard, transiting or mobile targets. Typically, these targets include: enemy troop concentrations or formations; fixed fortified positions; and mechanized or airmobile elements in the immediate battle area. The most favorable opportunities for Close Air Support normally occur during battle situations where enemy forces are on the move and thus are exposed to air attack. In all cases, effective Close Air Support requires close coordination between the air and land commanders in planning and conducting operations.

This annex to the Working Party Report addresses the application of a NAVSTAR/GPS to a postulated future fighter aircraft accomplishing a Close Air Support mission. Since NAVSTAR/GPS will not be operational until the mid 1980's, we selected a currently available "model" for our application study. The "model" was the F-4E aircraft equipped with the ARN-101 Weapon Delivery System. This was selected since it represents the current state-of-the-art externally aided (LORAN) digital avionics system integrated into a reasonably modern fighter aircraft which is currently in the operational inventory of several NATO countries. The aircraft has an attack radar, and the ability to carry a pod mounted electro-optical system and defensive avionics. It is also capable of delivering a broad selection of armaments useful in Close Air Support which includes: conventional MARK 80 series bombs; high drag weapons; smart bombs; missiles; and various cluster munitions.

## CHAPTER II - ARN-101 System Description

The integrated avionics for a future Close Air Support aircraft employing NAVSTAR/GPS will undoubtedly have many of the features currently found in the ARN-101(V) Digital Modular Avionics System (DMAS). Further, the experience gained in integrating such a system should be helpful in future NAVSTAR/GPS integration. The ARN-101 is an integrated navigation and weapon delivery system capable of accepting LORAN position updating. This system substantially improved the reliability and maintainability of the F-4E avionics, in addition to providing significant improvements in operational performance.

Figure 1 shows the most significant parts of the ARN-101 system. It consists of an inertial measurement unit, an inertial measurement unit buffer, a LORAN receiver, an antenna coupler, a central navigation/weapon delivery reconnaissance computer, a power supply, a signal data converter, LORAN X, Y and Z axis antennas (not shown), a keyer controller, and two digital display indicators.

The system uses the central navigation computer for integrating multi-sensor data to provide precise navigation information, and uses this information to perform the computations required for mission-related functions. These functions include long range and tactical navigation, precise "uncanned" (flexible) visual weapon delivery and all-weather blind bombing.

### F-4E AVIONICS SYSTEM DESCRIPTION

A block diagram for the F-4E is shown in Figure 2. The system provides long-range and tactical navigation outputs in three coordinate systems - latitude/longitude, Universal Transverse Mercator (UTM) and LORAN Time Differences (TD's). The central computer integrates inertial platform incremental velocity data with averaged samples of the LORAN signal in a Kalman filter to provide precise aircraft position and velocity information and torquing signals to the inertial platform. The system interfaces with the Multi-Mode Radar, Central Air Data Computer (CADC), Attitude Heading Reference System (AHRS), Flight Director System (FDS), Automatic Flight Control System (AFCS), Lead Computing Optical Sight System (LCOSS), and various mission related systems. Aircraft sensor inputs (e.g., radar and barometric data) are utilized by the central computer after analog-to-digital conversion in the signal data converter. An interactive control-display concept is utilized for data input and output in the back seat controller. The major ARN-101 subfunctions are described in the following paragraphs.

## AN/ARN-101

### • Digital Modular Avionics System

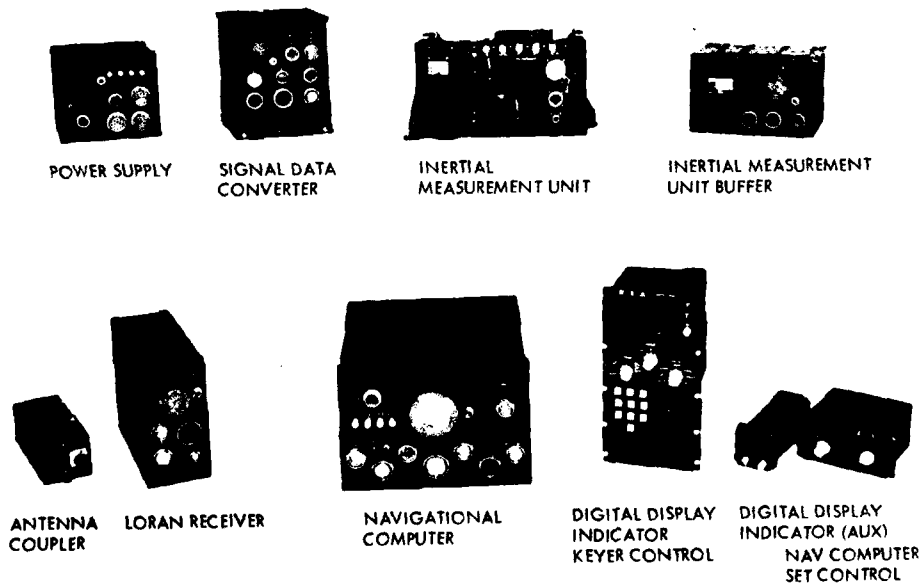

FIGURE 1

### NAVIGATION

The navigation functions consists of one primary mode and six back-up modes. Back-up modes are selected either manually, or automatically in the case of loss of valid LORAN or inertial data. The modes, in order of priority, are as follows:

- o Integrated LORAN-inertial (primary mode using Kalman filter)

- o LORAN with inertial velocity aiding
- o LORAN with true airspeed and heading aiding
- o Inertial only
- o LORAN only
- o Dead reckoning (true airspeed and heading)
- o Attitude (back-up INS attitude for displays)

The system is configured to allow in-flight position update using any of the available sensors (radar, LCOSS, TISEO, or Pave Tack) or manually through an over-fly technique.

The free-inertial navigation mode has demonstrated less than 1.0 nmi/h CEP and velocity errors less than  $\pm 4$  ft/s with either ground or Kalman filter airborne alignment.

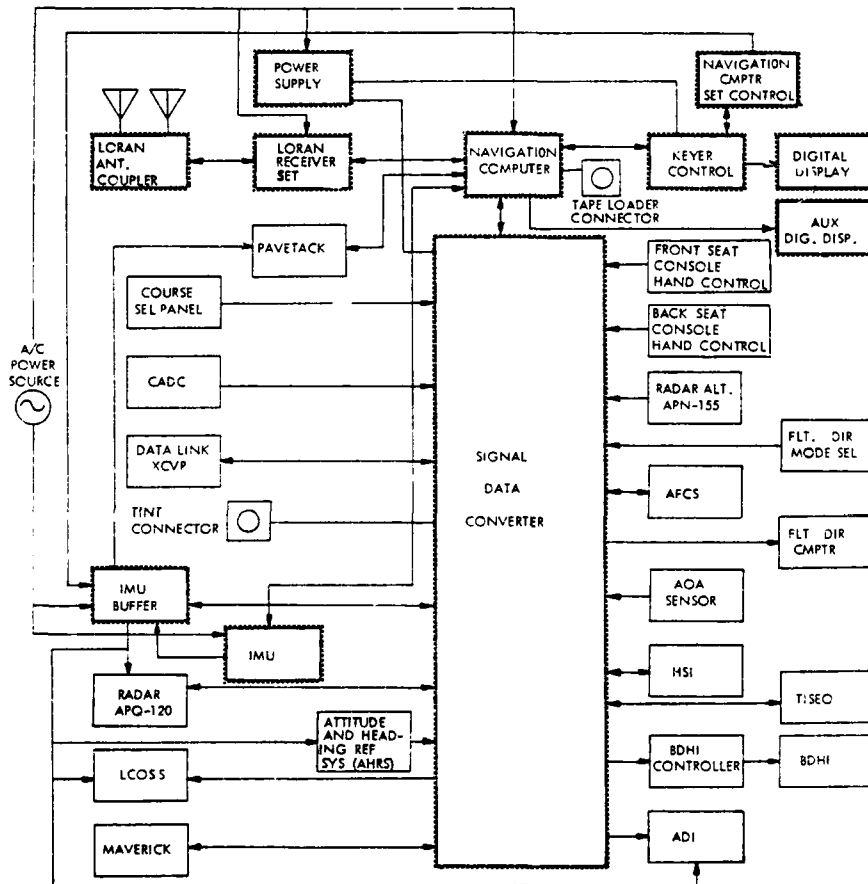

9727

FIGURE 2

### STEERING

The system computes steering to the operator-inserted destinations based on inserted or computed course data. Steering information is presented on the ARN-101 display, aircraft instruments, attitude director (ADI), LCOSS, and to the AFCS. The ARN-101 features the capability of automatic sequencing steering commands to up to 60 inserted waypoints or destinations with the option of fixed course or direct-track steering modes. Navigation parameters presented to the Aircraft Commander on the horizontal situation indicator (HSI) include aircraft magnetic heading, required magnetic heading to destination, keyboard selected course, deviation from selected course, selected course to-from destination, and distance to destination.

#### AUTOMATIC FLIGHT CONTROL SYSTEM COUPLING

The system provides lateral command signals to the AFCS for both the navigation modes, and the weapon delivery modes.

#### APPROACH-TO-LANDING

The approach-to-landing information is computed for display on the aircraft instruments and for automatic control via the AFCS based on deviations from a mathematical glide path generated in the central computer. Lateral position and velocity deviations from this path are obtained from the integrated LORAN/inertial information while vertical deviations are obtained from a blend of vertical axis inertial and barometric altimeter data. Accuracy of this mode should be sufficient to provide approach guidance for minimum landing approach conditions usually considered as 300 feet ceiling and one mile visibility in the USAF.

#### INTERACTIVE CONTROL-DISPLAY

A unique feature in the ARN-101 is the use of the keyer controller and digital display indicator in an interactive mode. Several data lists and checklists are provided under software control to cue and guide the backseat Weapon System Officer (WSO) through data input, data checking, and normal system operation. The interactive control-display is easily manipulated and followed and, more importantly, can be easily changed through software to reflect revised requirements.

#### DATA FREEZE

The system sorts certain flight data at the operator's command and places them in memory for later readout. The ARN-101 can hold 15 parameters relating to the present position. Position and velocity data describing each weapon release point is also automatically stored in the memory. It can also hold 15 parameters relating to present position and weapon release.

#### SENSOR CUEING/OFFSET TARGETING

Knowledge of present position, heading, and aircraft altitude can be used to cue aircraft or weapon sensors to targets of interest which have coordinates stored in the system's memory. The sensors include Pave Tack infrared/laser target designator, ASX-1 TISEO (Target Identification System, Electro-Optical), APQ-120 radar, ASG-26 optical sight, and the sensors for the AGM-65 Laser or IR Maverick missiles. Offset targeting is also provided to compute the geographical coordinates of any target being designated.

#### WEAPON DELIVERY

The ARN-101 provides the F-4E with the following weapon delivery modes: Blind (LORAN or Radar), Dive Toss, Continuously-Computed Impact Point (CCIP), Air-to-Ground Missile (AGM), Integrated (Timed LADD, Timed Offset, Loft) Delivery, and Air-to-Ground Guns and Rockets. The pilot is allowed complete freedom in his vertical maneuvering for weapon delivery after the "in-range" situation is computed. A dive angle cue is provided for use in the Blind mode to show the current allowable fixed dive angle to release.

Complete ballistic range estimation computations are performed by numerical integration every 200 milliseconds (ms) and adjusted through sensitivity coefficients every 50 ms. Release time is quantized to 1 ms. A fixed number (10) of integration steps provide an essentially constant execution time for all weapons and all release conditions, including drag weapons. There are only two basic drags (low and high drag) vs Mach functions stored; and each weapon is characterized by at least drag scale factor, Mach bias shift, and drag bias shift coefficients. A standard Runge/Kutta numerical integration technique of second order is used to solve the ballistic differential equations in a three-dimensional, ground-referenced coordinate system. The size of the time integration intervals is individually controlled for best overall accuracy, and dual dispenser (e.g., cannister) weapons are accounted for by changing coefficients at the trajectory transition point. The weapon total drag at each step is a function of the total weapon speed relative to the local air mass, thus permitting wind variations with altitude.

## CHAPTER III - Integrated NAVSTAR/GPS Digital Avionics System

The development of an Integrated NAVSTAR/GPS Digital Avionics System involves the design, fabrication and test of both hardware and software. The material presented here is an extension of a study which was done by Lear Siegler for the U.S. Air Force. That study addressed the integration of a NAVSTAR/GPS receiver with the previously discussed ARN-101 Weapon Delivery System. This report will be broken into three sections which discuss: the various hardware items and their interrelationships, the basic software implementation, and the results of performance simulation.

A draft specification is included in Appendix A. This specification is a skeleton which could be used by a systems engineer as a starting point in developing an integrated system using a NAVSTAR/GPS Receiver and a digital avionics architecture. Those modes and functions which are directly applicable to the NAVSTAR/GPS integration are discussed in detail. Requirements, such as interfaces with other on board equipment, (i.e., radar, electro-optical systems, "smart" weapons, etc.), are identified in Figure 3. Specific limits for many of the referenced performance parameters were left "to be determined" since they should be influenced by operational requirements, the current technology and acceptable system cost. Thus, this document can function as a point of departure in preparing a specification for a particular avionics system which could be integrated into a specific fighter/attack airframe.

The Integrated NAVSTAR/GPS Digital Avionics System will require considerable use of digital processing techniques. This capability may reside in a single or dual redundant central computer complex or it could be divided such that a portion of the digital processing is performed in each of several dedicated computers imbedded in the various sensors or a mixture of the above. For this study, the dedicated computers located in the four channel NAVSTAR/GPS User Equipment and the Standard (F<sup>3</sup>) Inertial Navigation Set (INS) will be utilized. A Central Processor will also be used to control the MIL-STD-1553 data bus interface with other sensors such as the Attack/Terrain Following/Terrain Avoidance Radar, the Electro-optical System and the intelligent weapons in order to facilitate target acquisition and weapon release. Redundancy will be provided as necessary to fulfill the mission success rate requirements.

The following capabilities will be provided:

- a. NAVSTAR/GPS Receiver - This unit, using its embedded processor, will compute the current position of each of four different satellites using the parameters provided in the GPS navigation message transmitted by each of the satellites. Also, the propagation delay due to the refraction of satellite's signal as they penetrate the earth's atmosphere will be estimated. Using these data, the

FIGURE 3

## INTEGRATED NAVSTAR/GPS DIGITAL AVIONICS SYSTEM ARCHITECTURE

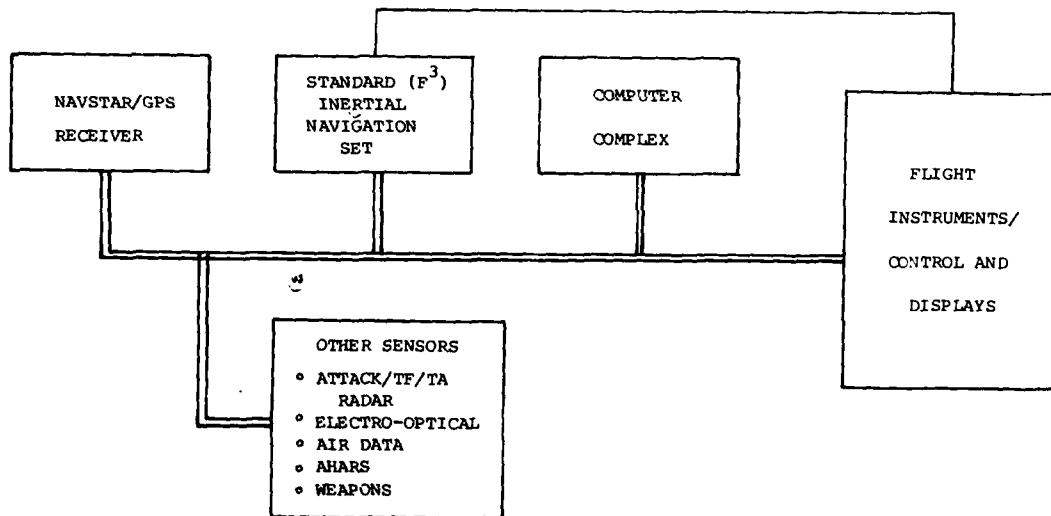

== MIL-STD-1553 DIGITAL DATA BUS

— HARDWARE FOR FLIGHT SAFETY DATA

unit will optimally estimate the range and range rate from each of four satellites plus the bias error and drift rate of the receiver's internal clock. Further, the velocity and attitude outputs from the INS will be used to rate aide the receiver when available.

The NAVSTAR/GPS processor will also perform the covariance matrix computations necessary to determine an estimate of position, velocity and system time from the receiver's estimate of range, range rate and clock error. These covariance matrix computations will result in an estimated geodetic position and velocity based on the WGS-72 coordinate system. This information can then be used to compute position and velocity in other coordinate systems such as:

Lat/Long

International UTM Spheriod

Airy UTM Spheriod

Hough UTM Spheriod

Clark 1866 UTM Spheriod

Clark 1880 UTM Spheriod

Everest UTM Spheriod

Bessel UTM Spheriod

Australian National UTM Spheriod

South American UTM Spheriod

The NAVSTAR/GPS processor will select four (4) satellites from the available ensemble which may include as many as eleven satellites at any one time. The satellite selection algorithm will select a set of four (4) satellites which will provide the best navigation accuracy based upon satellite health (transmitted in satellite navigation messages) and the geometric dilution of position.

The NAVSTAR/GPS processor will also perform the executive functions within the NAVSTAR/GPS receiver such as automatically initiating search, synchronization, track reacquisition and calibration modes.

The NAVSTAR/GPS receiver will provide a stand alone navigation capability which can be used whenever inputs from the INS or other auxillary heading reference systems are not available.

b. Standard (F<sup>3</sup>) Inertial Navigation Set - The data processor contained within this unit includes the capability to achieve alignment while stationary or airborne using inputs from the NAVSTAR/GPS receiver or other available sensors. The Standard (F<sup>3</sup>) Inertial Navigation Set will also contain an autonomus navigation capability, once aligned, which can operate independently in the event the NAVSTAR/GPS receiver would be jammed. These computations will again be based upon the WGS-72 coordinate system.

c. NAVSTAR/GPS-INS Kalman Filter - An eleven state Kalman Filter will reside in the central computer processor. This filter will optimally integrate the data provided by both the NAVSTAR/GPS Receiver and the Standard (F<sup>3</sup>) Inertial Navigation Set or other sensors depending upon the mode selected by the operator. Both open and closed loop operation will be provided. In the open loop mode of operation, the integrated GPS/inertial navigation outputs will be computed by adding the Kalman Filter error estimates to the INS outputs. This will allow completely independent operation of the two systems and thus prevent the possibility of invalid NAVSTAR/GPS data degrading the inertial's performance. During closed loop operation, the inertial variables and platform verticality will be updated using the Kalman Filter estimates. This will provide an in-flight alignment capability for the INS. The Kalman Filter will continuously process valid NAVSTAR/GPS information regardless of the selected navigation mode, thus eliminating the waiting necessary for the Kalman Filter outputs to converge when the integrated mode is selected by the operator.

The central processor will also monitor the health of each of the other sensors, annunciate failures and accomplish an automatic reversion to a backup mode. For example, in event of a failure within the NAVSTAR/GPS receiver, the system would automatically select a pure inertial mode with an attendant loss of system accuracy. However, if the INS was the sensor to fail, the system would then revert to the GPS only mode with an attendant loss of anti-jam margin.

d. Controls and Displays - Appropriate controls and displays will be required to interface with the various components of the Integrated NAVSTAR/GPS Digital Avionics System. Data input, retrieval and mode selection will be accomplished via keyboard and rotary function switches. Outputs will be displayed on alpha/numeric displays and flight displays. The flight displays may be of either a cathode ray or servo-mechanical type depending upon the candidate air vehicle and the other sensors/weapons which must be accommodated. Digital data transfer will be accomplished via the MIL-STD-1553 data bus.

Weapon Delivery

The Integrated NAVSTAR/GPS Digital Avionics System will provide the capabilities to place or direct weapons on a target in either visual or blind modes. During visual bombing against targets with unknown position coordinates, the performance will be similar to those achieved by current sophisticated weapon systems. However, when operating against targets with known coordinates, the integrated system will significantly improve the probability of success by assisting the operator in acquiring the target earlier and thus increasing the time for maneuvering prior to weapon release. For blind delivery against targets with known coordinates, the probability of success will be greatly enhanced.

## CHAPTER IV - Navigation/Weapon Delivery Performance Simulation

A digital simulation was performed using; a mathematical model of a NAVSTAR/GPS receiver, the performance characteristics of an INS comparable to the STD-INS, Mark 80 series bomb dynamics, and a Kalman Filter mechanized as described in Appendix B.

Simulation Description

Basically, the simulation program solves a set of equations for the navigation errors, consideration is given to the effects of the aircraft profile and GPS/INS error sources. The major steps in the simulation are:

- a. Solving the set of difference equations which describe the dynamics of the INS and GPS sensors.
- b. Integrating GPS and INS information by iterating a GPS/Inertial Kalman Filter algorithm to estimate the significant INS and GPS errors.

A block diagram for the simulation is given in Figure 4. One major block is the INS and GPS error dynamics model where the error difference equations are solved. The outputs of this block are the errors in the integrated GPS/Inertial's position, velocity, wander angle, platform verticality, time and clock drift bias estimates. The difference equations represent a linear error model for the inertial and GPS errors; however, second order wander angle error terms are included for their effect during the in-flight INS alignment simulation runs.

FIGURE 4

## INTEGRATED GPS/INERTIAL SIMULATION

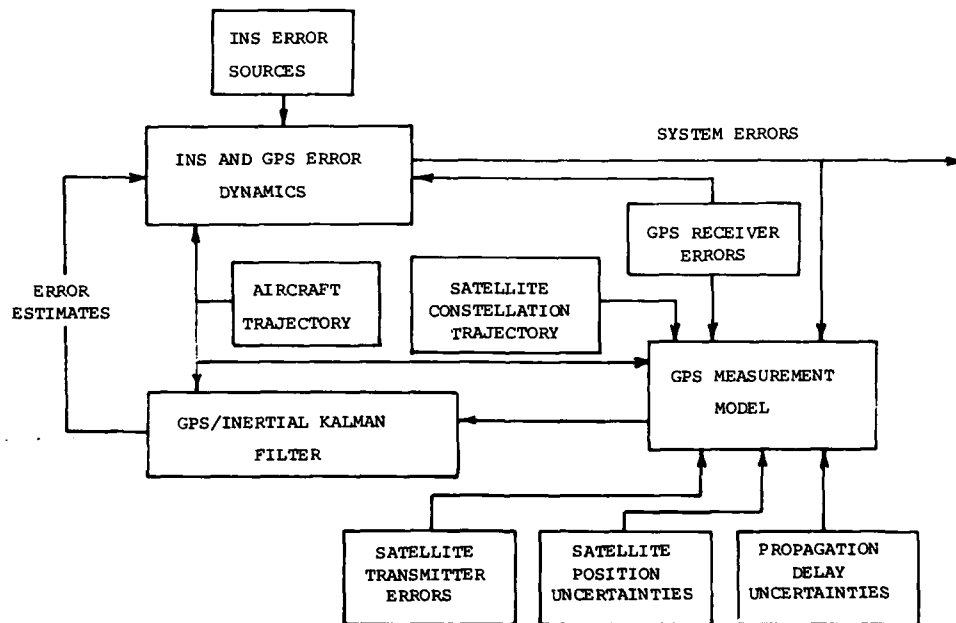

The terms in the error difference equations are functions of the aircraft trajectory, INS errors sources, and GPS receiver errors. Represented are the INS errors as defined in Table 1 and the GPS receiver errors defined in Table 2. A realistic aircraft profile was generated with a six (6) degrees of freedom fighter aircraft simulator. The profile, which consists of the aircraft position, velocity, attitude and heading variables stored on tape, was created by an engineer/pilot "flying" the aircraft simulator. He "flew" a preplanned profile specifically developed to exercise the GPS/Inertial Kalman Filter and include the maneuvers normally expected from a fighter aircraft.

SYMBOL	DESCRIPTION	STANDARD DEVIATION	COMMENTS
$\zeta_{xy}, \zeta_{xz}, \zeta_{yx},$ $\zeta_{yz}, \zeta_{zx}, \zeta_{zy}$	MISALIGNMENTS	33 sec.	Bias
$\epsilon K_x, \epsilon K_y, \epsilon K_z$	SCALE FACTOR ERRORS	.05%	Bias
$K_{xL}, K_{yL}, K_{zL}$	LONG TERM BIASES	316 $\mu$ g	Bias
$K_{xs}, K_{ys}, K_{zx}$	SHORT TERM BIASES	20 $\mu$ g	Correlation time = 7200 sec.
$n_x, n_y, n_x$	RANDOM NOISES	30 $\mu$ g	Correlation time = 5 sec.
$K_{cx}, K_{cy}, K_{cz}$	ACCELERATION SENSITIVE SCALE FACTOR ERRORS	$10^{-4}$ /g	Bias
$k_{2x}, k_{2y}, k_{2z}$	2ND ORDER NON-LINEARITIES	30 $\mu$ g/g <sup>2</sup>	Bias
$g_x, g_y$	GRAVITY DEFLECTIONS	25 $\mu$ g	Correlation distance = 20 nm
$\eta_{xy}, \eta_{xz}, \eta_{yx},$ $\eta_{yz}, \eta_{zx}, \eta_{zy}$	MISALIGNMENT ANGLES	40 sec.	Bias
$K_{1L}, K_{2x}, K_{2y},$ $K_{1A}, K_{2z}$	MASS-UNBALANCES	0.17deg/hr/g	Bias
$K_{3x}, K_{3y}, K_{3z}$	ANISOELASTICITIES	.0067deg/hr/g <sup>2</sup>	Bias
$b_{xs}, b_{yx}$	DRIFT REPEATABILITIES	.012 deg/hr	Correlation time = 3600 sec.
$b_{zs}$	DRIFT REPEATABILITY	.03 deg/hr	Correlation time = 3600 sec.
$N_x, N_y, N_z$	RANDOM ERRORS	.005deg/hr	Correlation time = 100 sec.
$\epsilon S_x, \epsilon S_y, \epsilon S_z$	SCALE FACTOR ERRORS	.05%	Bias
$\epsilon\phi, \epsilon\theta, \epsilon\psi$	ROLL, PITCH, AZIMUTH MEASUREMENT ERRORS *	$\pm 3.5$ min.	Noise with uniform distribution

\*LEVER ARM COMPENSATION USED IN ERROR MODEL FOR ANTENNA - 4.7 m

TABLE 1 - INS ERROR SOURCES

Another major block in the simulation is the GPS measurement model. This block contains a mathematical representation of the receiver's four pseudo-range and range-rate measurements. The outputs of this block, which are supplied to the Kalman Filter, are the differences between the receiver measurement and the Kalman Filter estimates of these measurements. These differences are a function of the following: a) the integrated GPS/Inertial errors and b) the uncertainties in satellite; positions, transmitter times, signal propagation delays, and GPS receiver measurements. Geometric dilution of precision has a significant effect in that it is a function of both aircraft position and the position of the four satellites.

The GPS/Inertial Kalman Filter processes "state measurements" - in this case the four pseudo ranges and range-rates minus their estimates - and estimates INS and GPS errors. To reduce the integrated GPS/Inertial errors, these error estimates are subtracted from the solutions in the error dynamics simulation block.

## GPS SYSTEM AND RECEIVER ERROR BUDGET

	ERROR	ACCURACY (1 $\sigma$ )
RANGE ERROR COMPONENTS	SPACE VEHICLE TIME ERROR	2.7M
	RANGE ERROR (P SIGNAL)	1.5M
	EPHEMERIS MODEL FIT	.1M
	EPHEMERIS PREDICTION ERROR	3.5M
	TROPOSPHERIC DELAY ERROR	2.0M
	MULTIPATH ERROR	2.0M
	RECEIVER CHANNEL DELAY VARIATION	1.5M
	IONOSPHERIC CORRECTION UNCERTAINTY	2.3M
RANGE RATE ERROR COMPONENTS	RANGE RATE ERROR (P SIGNAL)	.012M <sup>(3)</sup> .02M/.006M
	RECEIVER OSCILLATOR (SHORT TERM STABILITY)	.03M/SEC/SEC
	RECEIVER OSCILLATOR (G SENSITIVITY)	.9M/SEC/G

TABLE 2

An eleven state Kalman Filter was simulated and a simplified block diagram of it is shown in Figure 5. The 11 states represent errors in the following variables:

- x velocity
- y velocity
- z velocity
- latitude
- longitude
- wander angle (x accelerometer relative to north)
- x platform verticality
- y platform verticality
- altitude
- time
- receiver clock drift bias (oscillator frequency bias)

THIS PAGE IS UNCLASSIFIED  
FROM GPO. DATE 11-19-2000

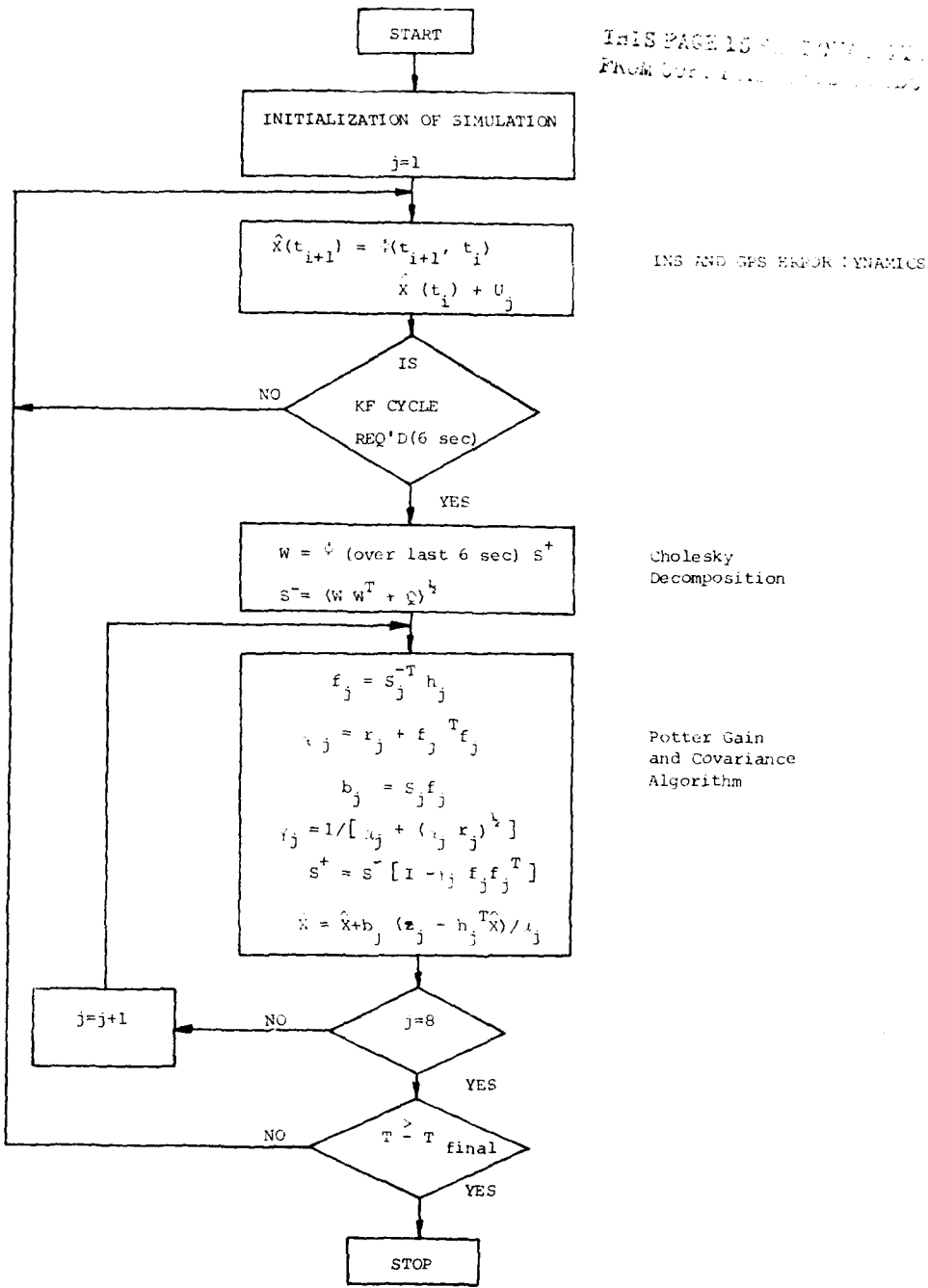
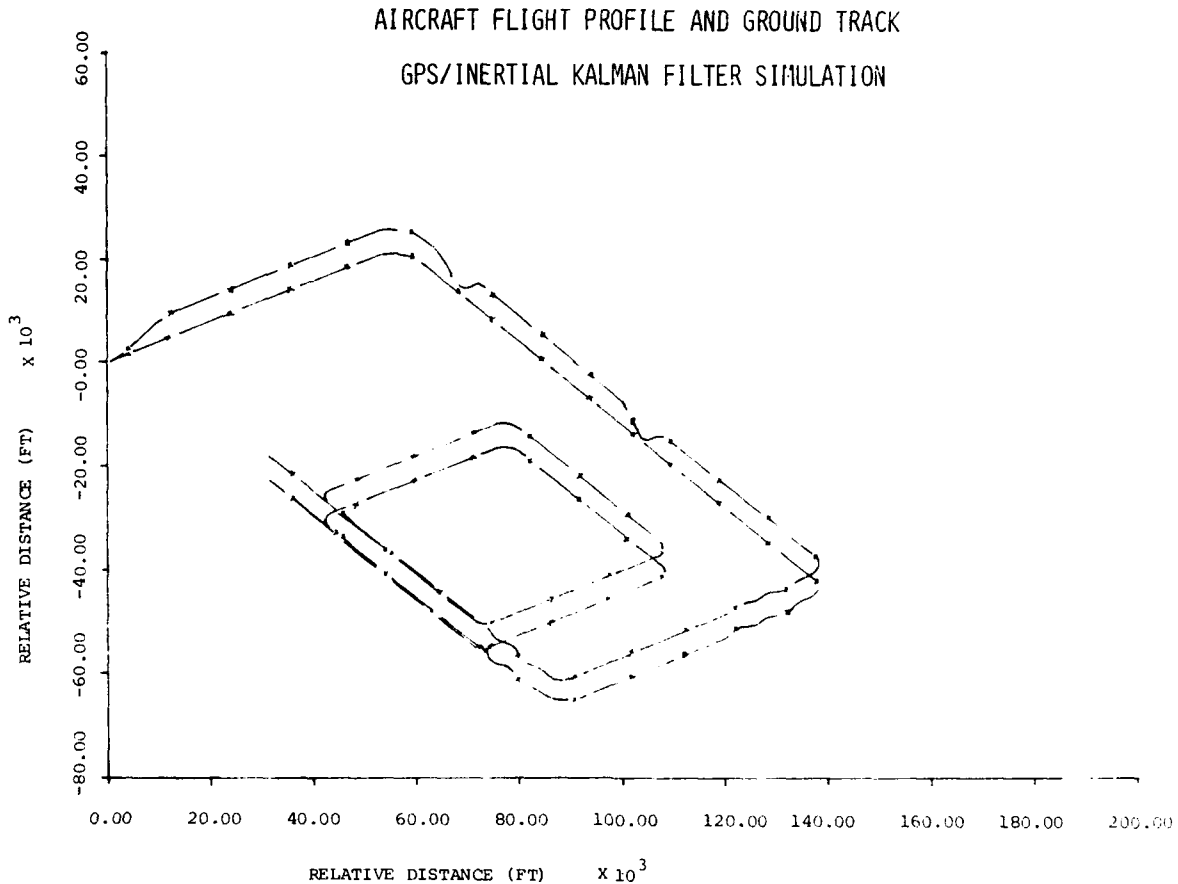

FIGURE 5 - KALMAN FILTER EQUATIONS/SOLUTION SEQUENCE

SIMULATION CONDITIONS

The various horizontal and vertical maneuvers on the simulated aircraft trajectory are illustrated in the 3-dimensional perspective plot given in Figure 6. The top line on the plot is the aircraft trajectory and the bottom line is the ground track. Every 42 seconds during the simulation, the aircraft location is marked with a "+" symbol. This allows a correlation to be made between the profile plot and the following brief description of the profile:

- a. Takeoff to 4600 m at 450 knots followed by a straight and level flight.
- b. Turn to 90 degree heading



c. Two segments of climbs and dives (dive to 1525 m with 4g pull-up, back up to 4600 m altitude) with 2 minutes of wings level following each segment.

d. Two jinking segments followed with 2 minutes of straight and level after each segment - turn to 180 degree heading between jinking maneuvers.

e. A square racetrack pattern with four 2 minute legs and 2 g turns. The profile's initial point is at 32 degrees 43 minutes latitude, 114 degrees 36 minutes west longitude.

The values used in the simulation for the INS error sources are listed in Table 1. The GPS error sources and values are given in Table 2. As indicated above, these are the contributions of the individual inertial sensor measurement errors and the four GPS range and range-rate errors to the integrated GPS/Inertial navigation errors.

In the simulation, the GPS/Inertial Kalman Filter processed the four pseudo-range and range-rates every 6 seconds. The noises added to the range and range-rate receiver measurements are gaussian with zero means. The range-rate model assumed a 0.1 second integration interval. The noise samples every 6 seconds were uncorrelated; i.e., a discrete white noise model was used for the receiver noise.

As indicated, the Kalman Filter processed GPS measurements every 6 seconds. To establish the sensitivity of the GPS/Inertial Kalman Filter performance to the rate that GPS data is processed, a simulation run was made where the pseudo-ranges were processed every 12 seconds. The performance results are given below in the SIMULATION RESULTS section.

Although the Kalman Filter algorithm was computed every 6 seconds, other computations in the simulation were performed more often. The set of difference equations that define the time variations of the errors were computed once every second. And within each one second interval, individual terms were processed every 0.1 second to accurately represent the INS error transients during aircraft maneuvers. The parameters defining the aircraft profile were recorded at a 10 hertz rate when the profile was created with the aircraft simulator.

## SIMULATION RESULTS

Results for distinct simulation runs are presented in this study. Each run shows the performance for both the in-flight INS alignment mode and the integrated GPS/Inertial navigation mode. The three simulation runs represent the following tests:

Run #1: In-flight INS alignment starting from the ground.

Run #2: In-flight INS alignment starting at the top of the second dive in the profile.

Run #3: Same conditions as Run #2 only with the Kalman Filter processing GPS pseudo ranges every 12 seconds instead of every 6 seconds.

The data plots generated during these runs are presented on Figures 7 through 39. There are a number of lines on each plot. The solid line is the actual error that occurred for the simulation run. The two dashed lines are the one sigma envelope for the error. These error standard deviations (1 sigma) were calculated as part of the Kalman Filter algorithm and are a good approximation to the error statistics that would be obtained from an ensemble of Monte Carlo runs.

The results of the simulation runs can be summarized as follows:

a. The position error is dominated by the uncertainties of the slowly varying GPS range errors due to satellite position uncertainties, transmitter time, and propagation delays. The same values were used for these error sources to maintain the same position error means for all three runs.

FIGURE 7

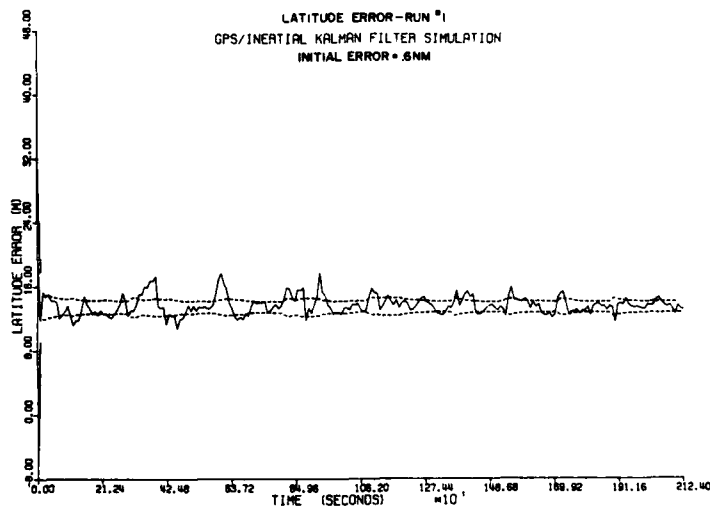

FIGURE 8

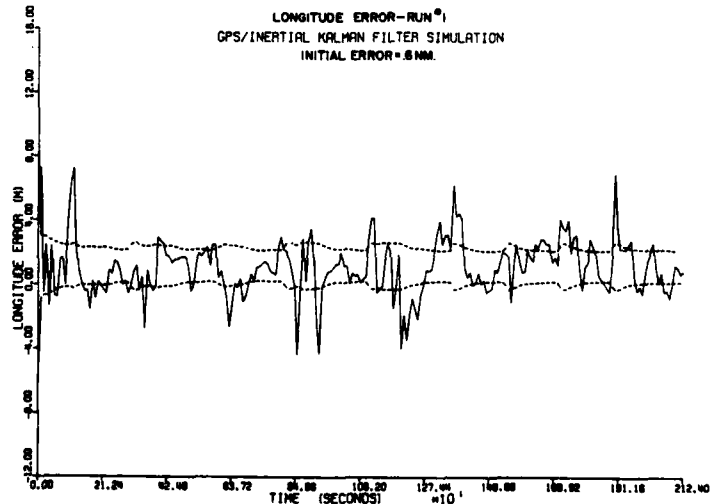

FIGURE 9

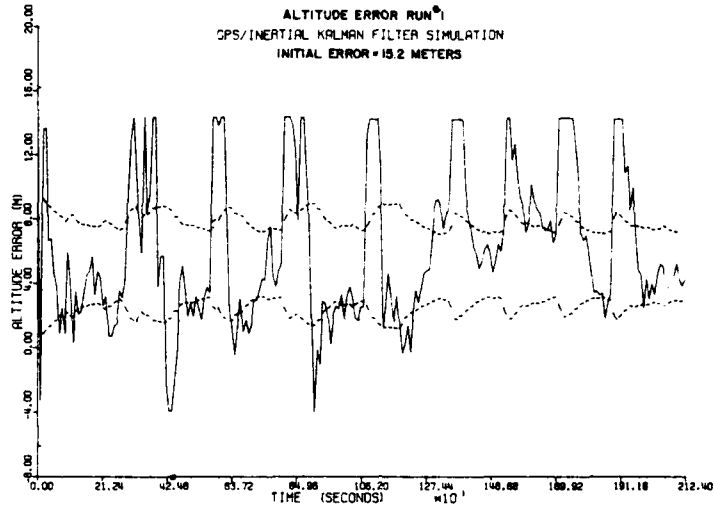

FIGURE 10

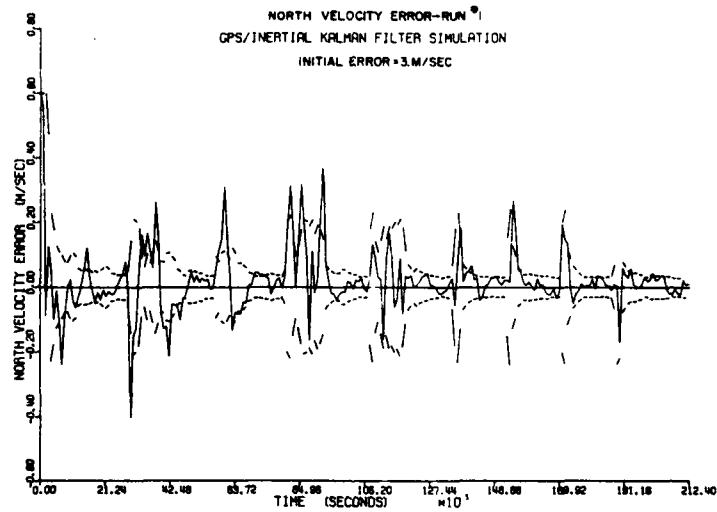

FIGURE 11

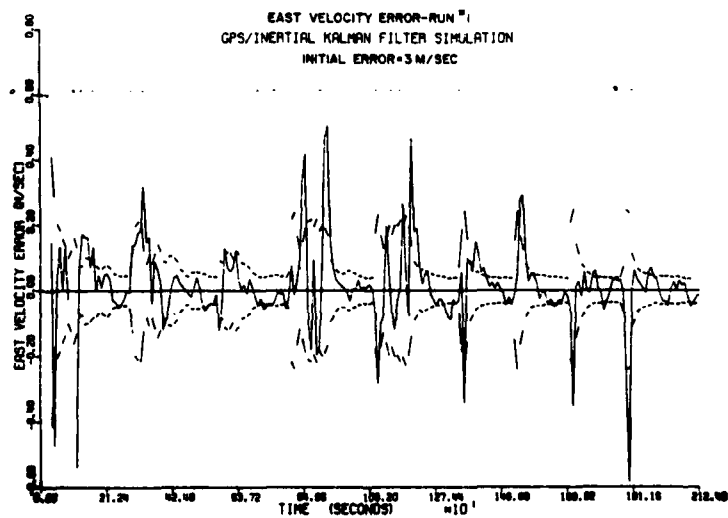

FIGURE 12  
 VERTICAL VELOCITY ERROR-RUN #1  
 GPS/INERTIAL KALMAN FILTER SIMULATION  
 INITIAL ERROR=3.0 M/SEC

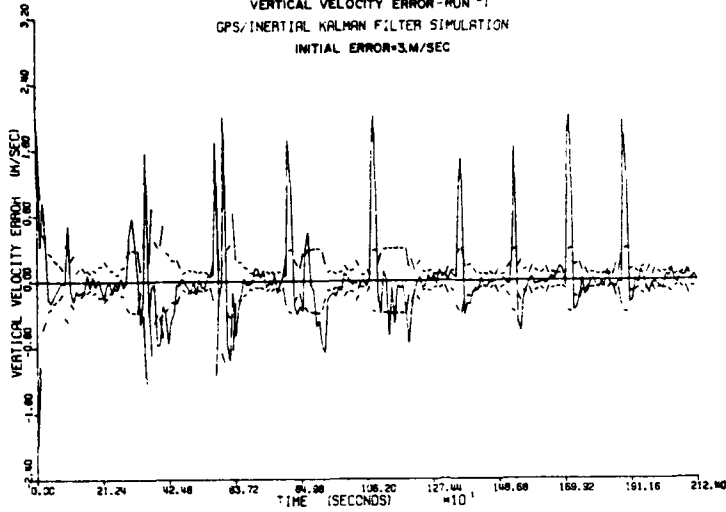

FIGURE 13  
 WANDER ANGLE ERROR-RUN #1  
 GPS/INERTIAL KALMAN FILTER SIMULATION  
 INITIAL ERROR=-5 DEGREES

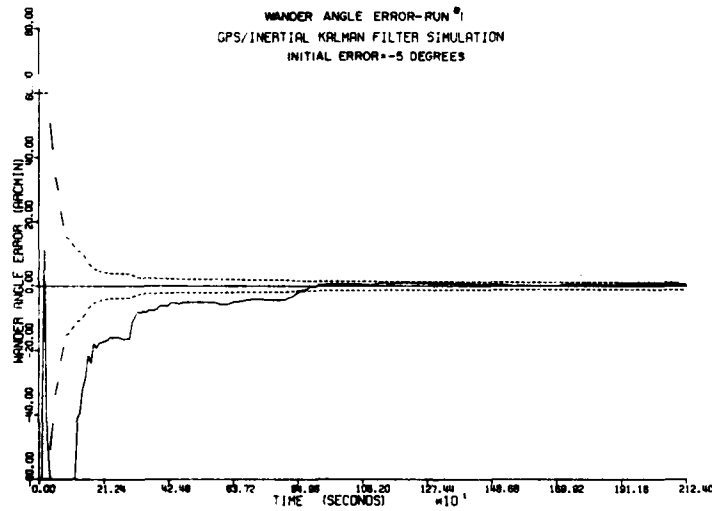

FIGURE 14  
 X AXIS MISLEVEL-RUN #1  
 GPS/INERTIAL KALMAN FILTER SIMULATION  
 INITIAL ERROR=2 DEGREES

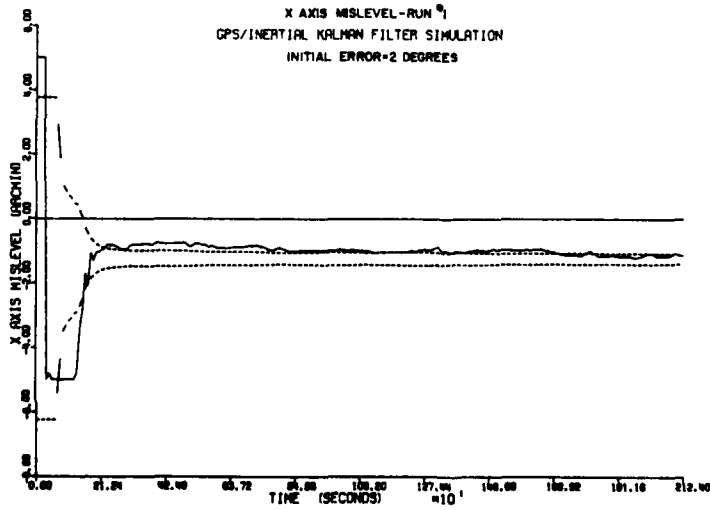

FIGURE 15  
Y AXIS MISLEVEL-RUN #1  
GPS/INERTIAL KALMAN FILTER SIMULATION  
INITIAL ERROR=2 DEGREES

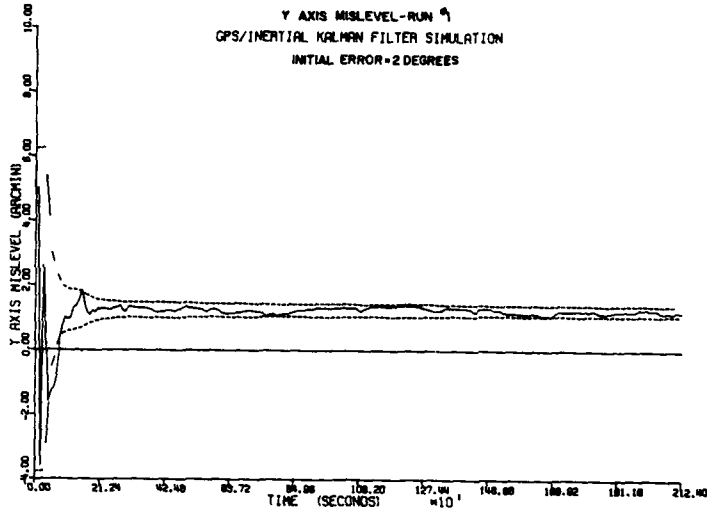

FIGURE 16  
RECEIVER CLOCK OFFSET ERROR-RUN #1  
GPS/INERTIAL KALMAN FILTER SIMULATION  
INITIAL ERROR=1 SEC

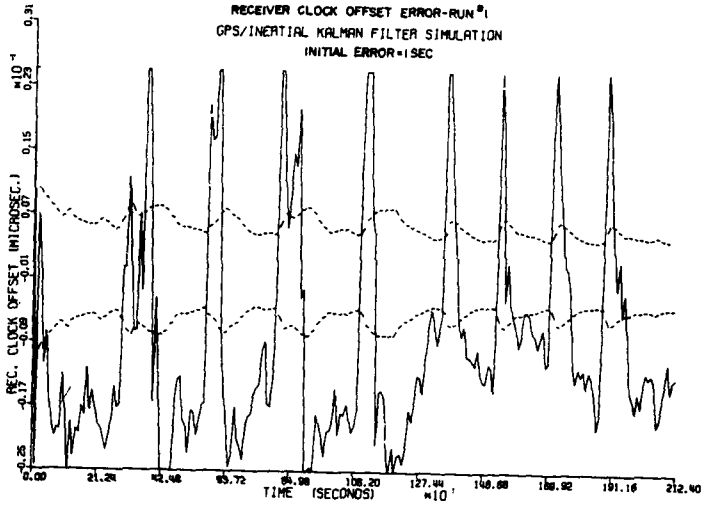

FIGURE 17  
RECEIVER CLOCK DRIFT-RUN #1  
GPS/INERTIAL KALMAN FILTER SIMULATION  
INITIAL ERROR=10^-8 SEC/SEC

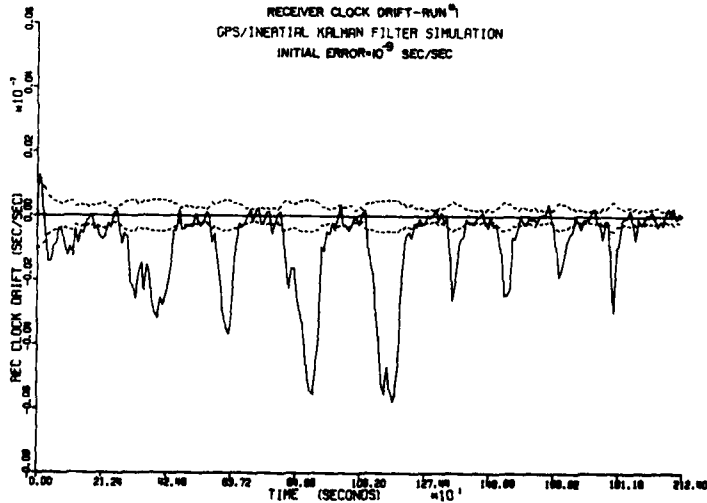

FIGURE 18  
 LATITUDE ERROR-RUN #2  
 GPS/INERTIAL KALMAN FILTER SIMULATION  
 INITIAL ERROR=5NM

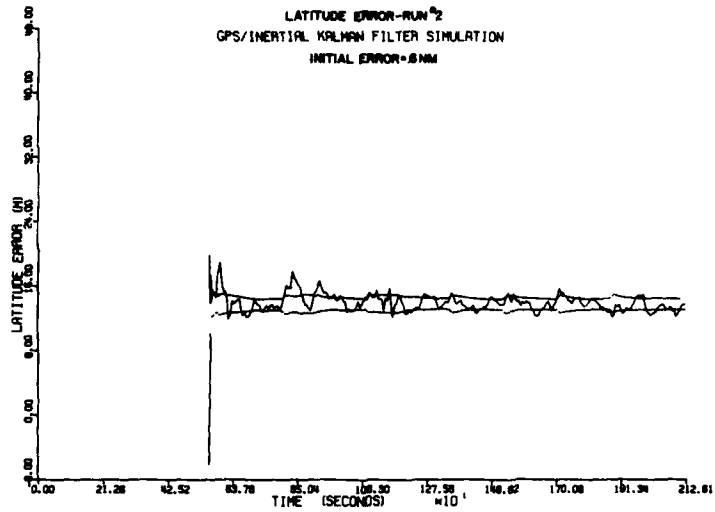

FIGURE 19  
 LONGITUDE ERROR-RUN #2  
 GPS/INERTIAL KALMAN FILTER SIMULATION  
 INITIAL ERROR=5NM

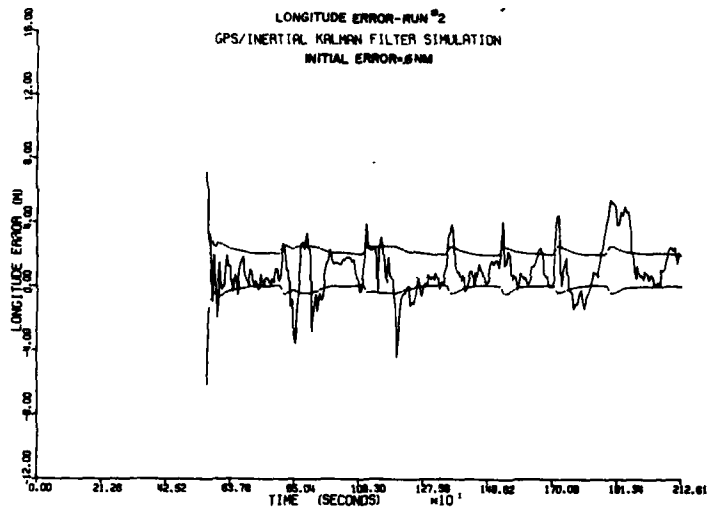
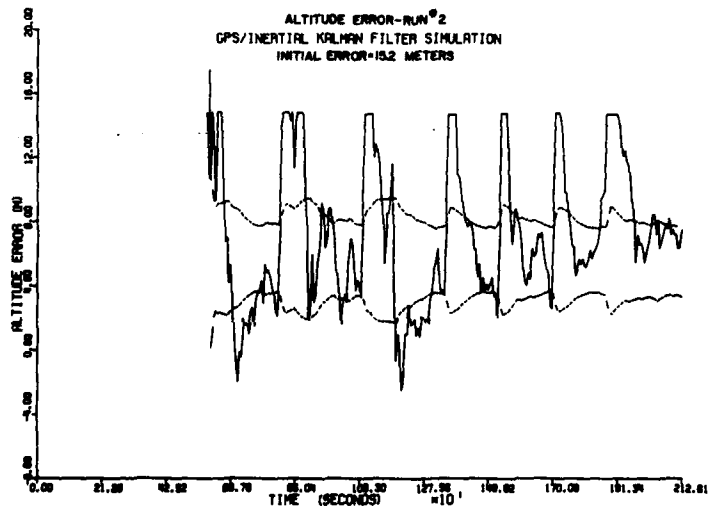

FIGURE 20  
 ALTITUDE ERROR-RUN #2  
 GPS/INERTIAL KALMAN FILTER SIMULATION  
 INITIAL ERROR=15.2 METERS



THIS PAGE IS BEST QUALITY PRACTICABLE  
 FROM COPY FURNISHED TO DDC

FIGURE 21  
NORTH VELOCITY ERROR-RUN#2  
GPS/INERTIAL KALMAN FILTER SIMULATION  
INITIAL ERROR=3M/SEC

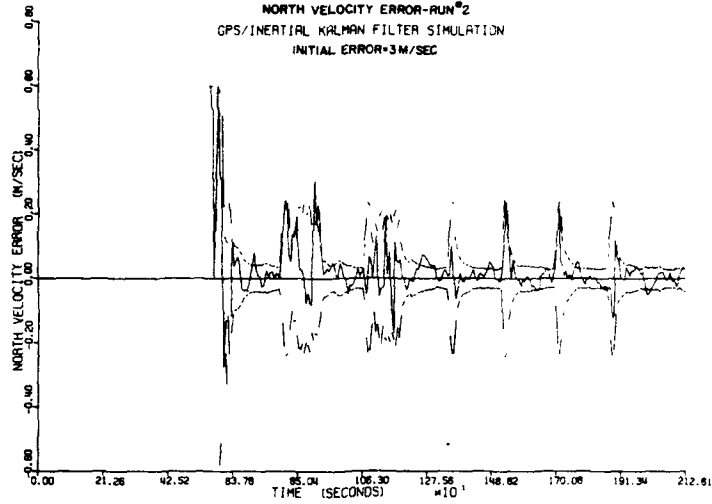

FIGURE 22  
EAST VELOCITY ERROR-RUN#2  
GPS/INERTIAL KALMAN FILTER SIMULATION  
INITIAL ERROR=3M/SEC

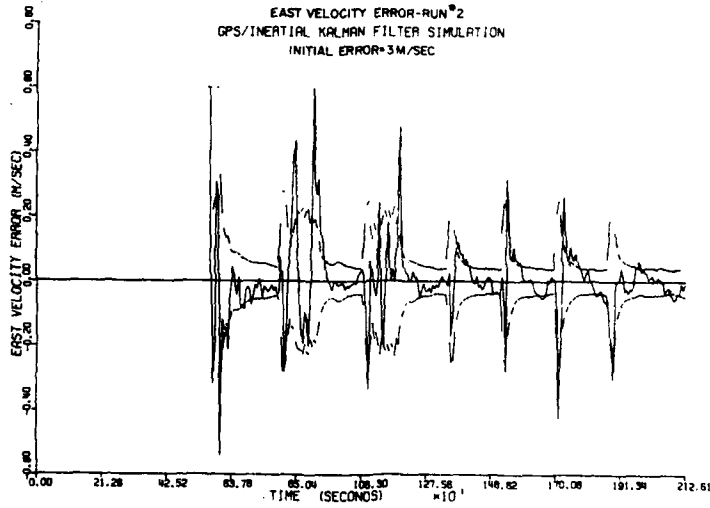

FIGURE 23  
VERTICAL VELOCITY ERROR-RUN#2  
GPS/INERTIAL KALMAN FILTER SIMULATION  
INITIAL ERROR=3M/SEC

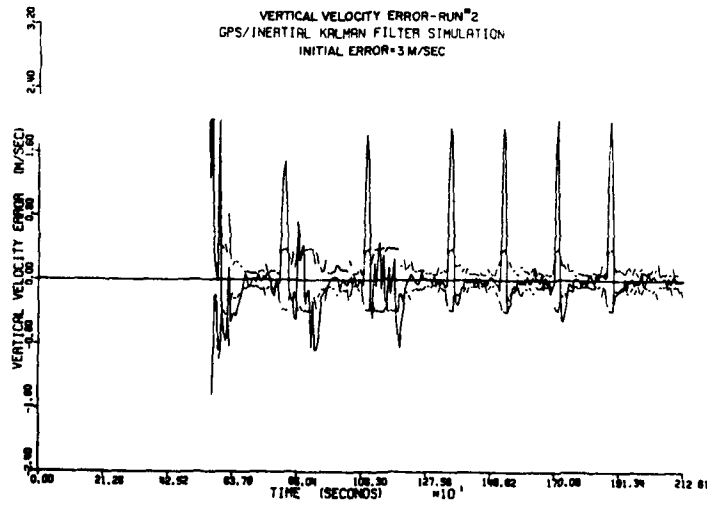

FIGURE 24

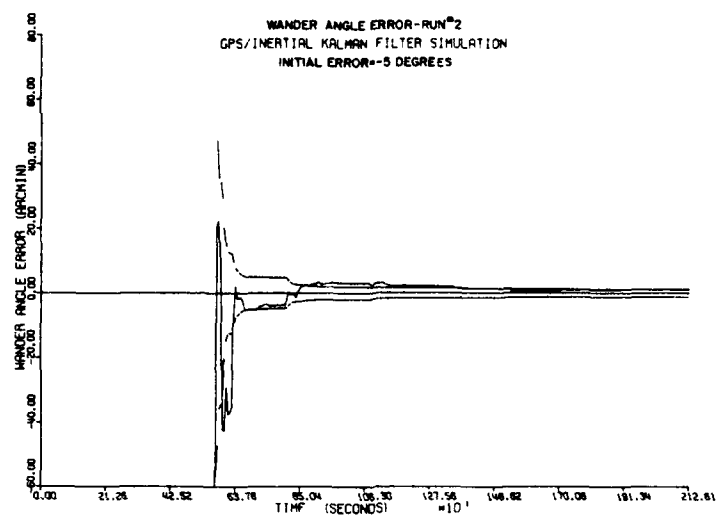

FIGURE 25

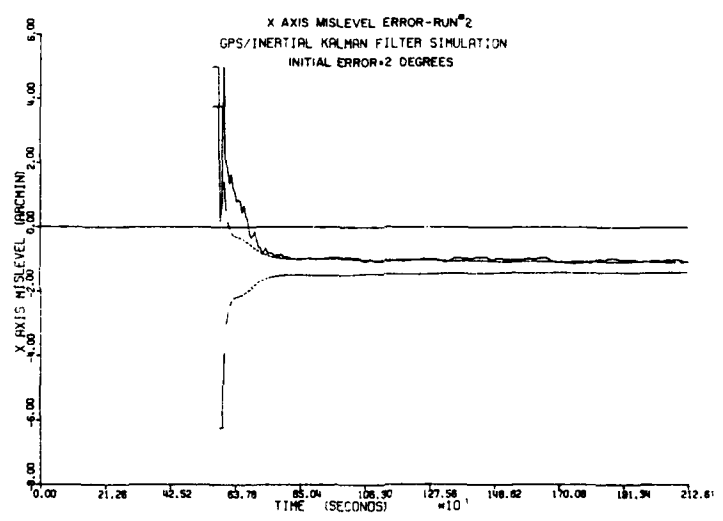
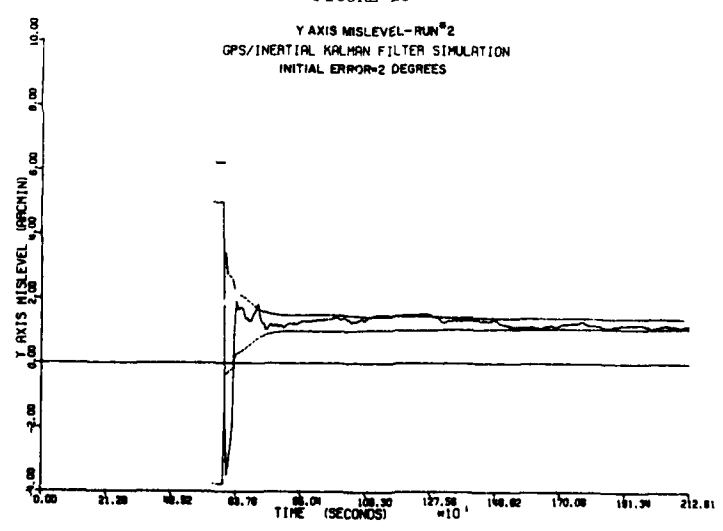

FIGURE 26



THIS PAGE IS BEST QUALITY REPRODUCTION  
FROM COPY FURNISHED TO NSC

FIGURE 27

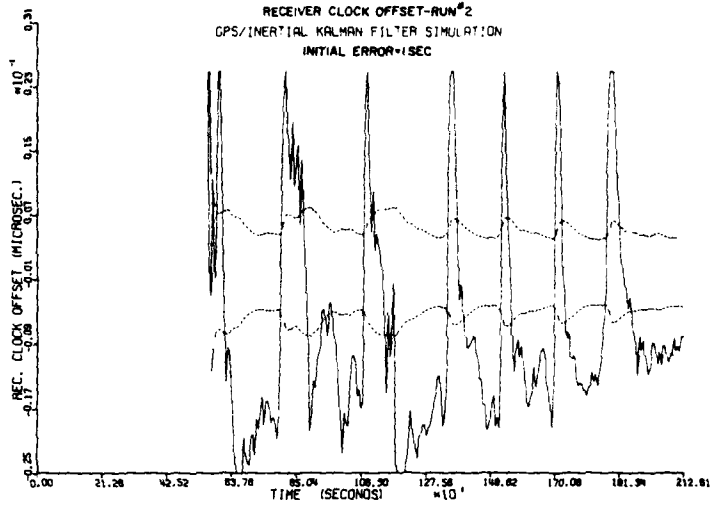

FIGURE 28

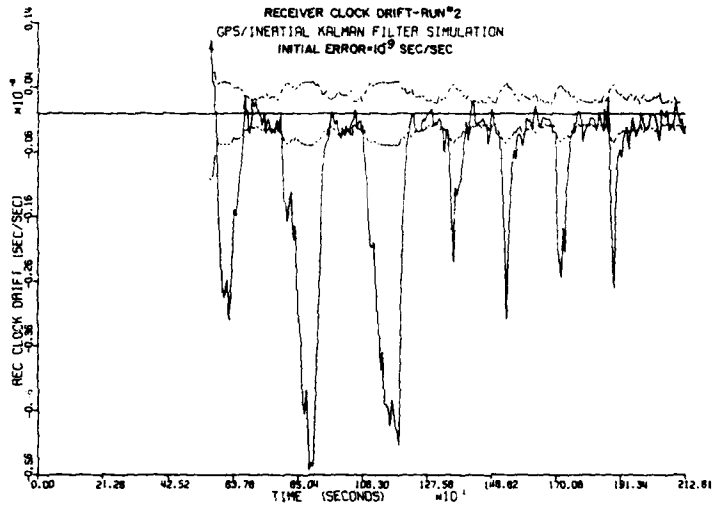
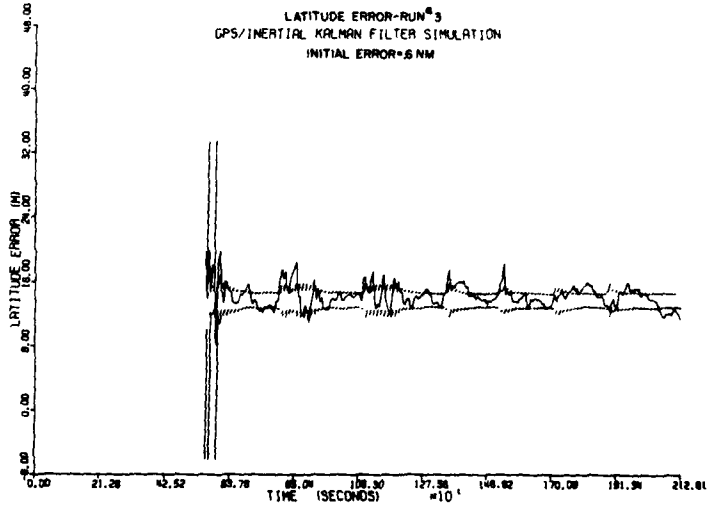

FIGURE 29



THIS PAGE IS BEST QUALITY PRACTICABLE  
FROM COPY FURNISHED TO DDC

FIGURE 30

LONGITUDE ERROR-RUN<sup>3</sup>  
GPS/INERTIAL KALMAN FILTER SIMULATION  
INITIAL ERROR=6 NM

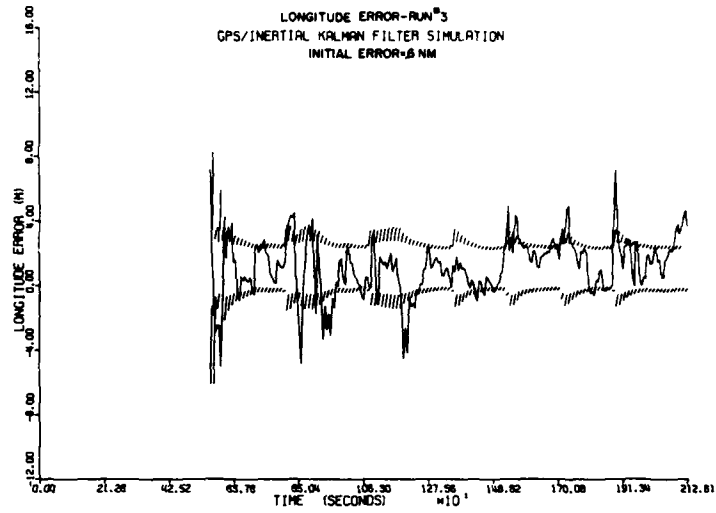

FIGURE 31

ALTITUDE ERROR-RUN<sup>3</sup>  
GPS/INERTIAL KALMAN FILTER SIMULATION  
INITIAL ERROR=15.2 METERS

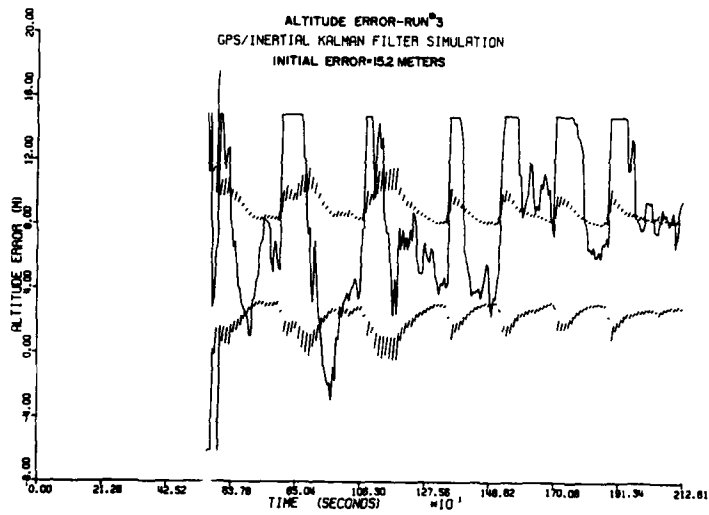
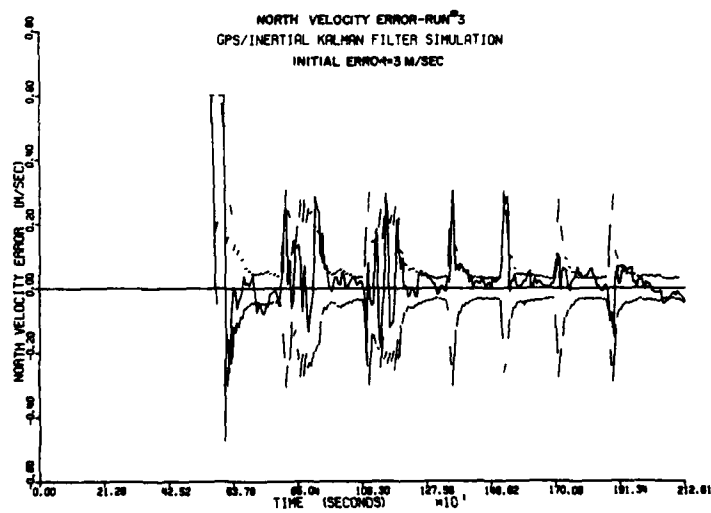

FIGURE 32

NORTH VELOCITY ERROR-RUN<sup>3</sup>  
GPS/INERTIAL KALMAN FILTER SIMULATION  
INITIAL ERROR=3 M/SEC



THIS PAGE IS BEST QUALITY AVAILABLE  
FROM COPY FURNISHED TO DDC

FIGURE 33

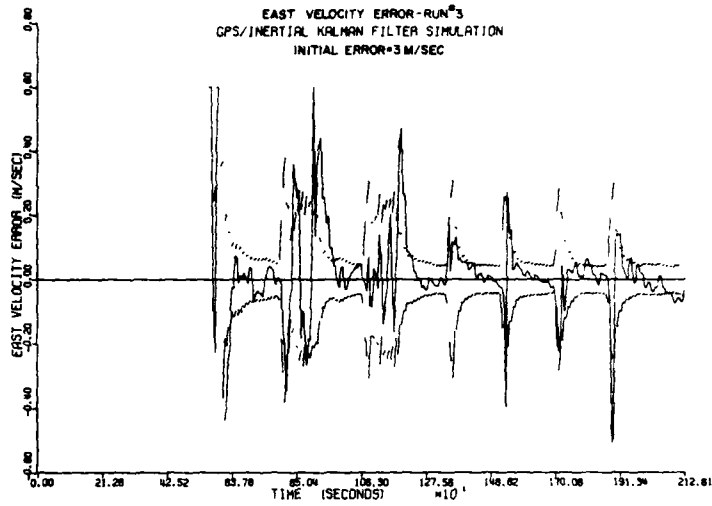

FIGURE 34

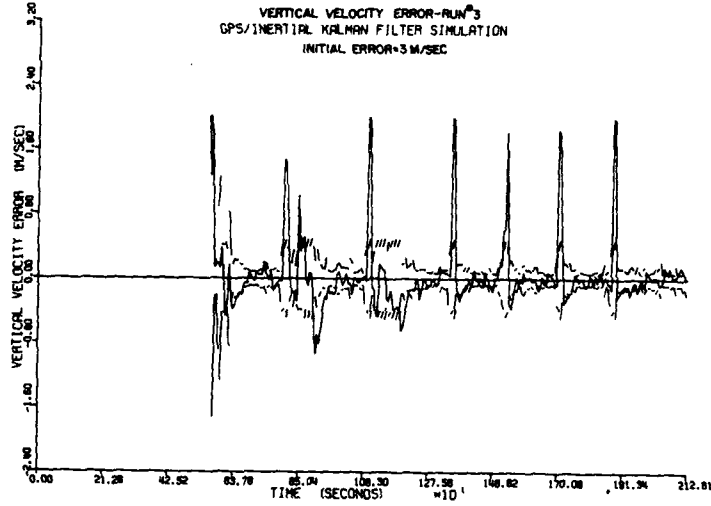

FIGURE 35

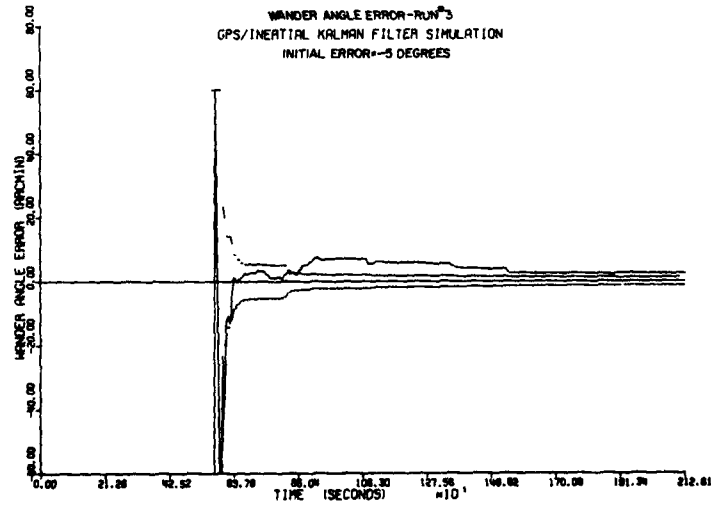

FIGURE 36

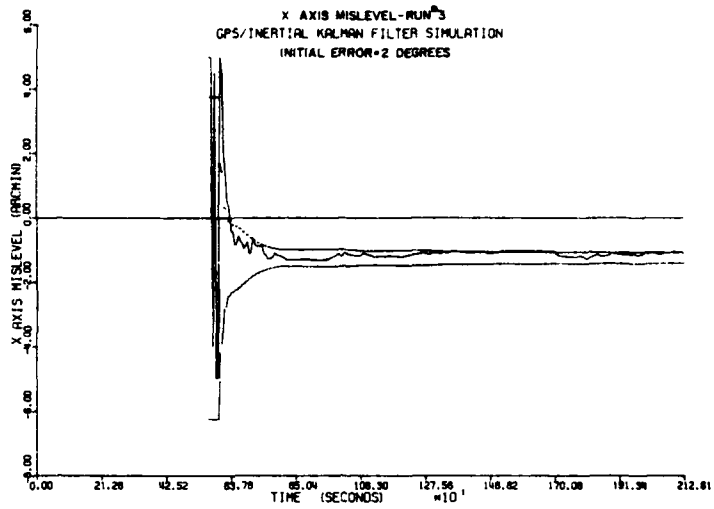

FIGURE 37

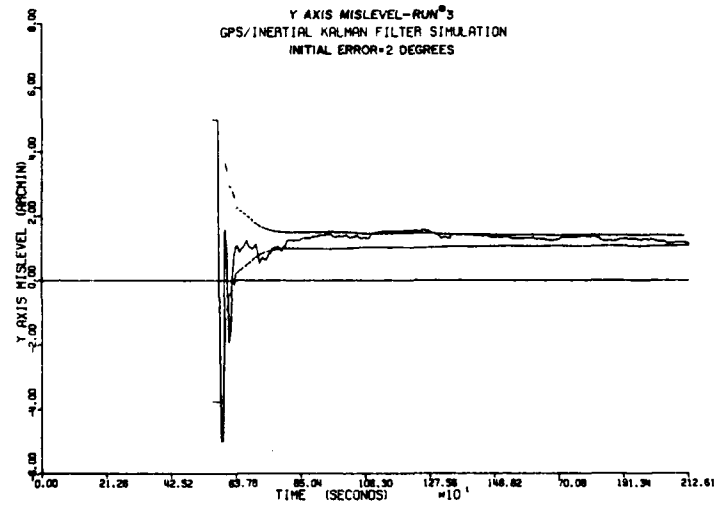
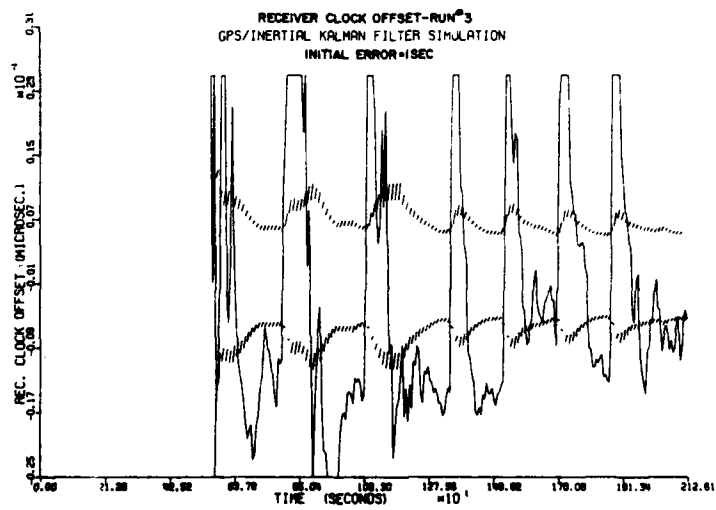
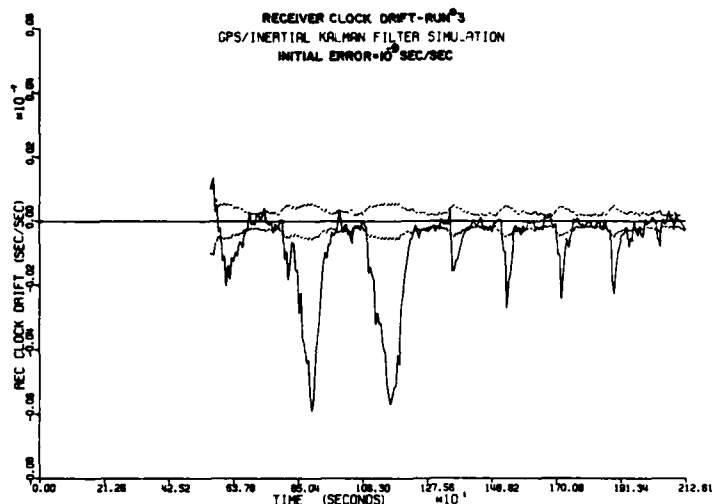

FIGURE 38



THIS PAGE IS BEST QUALITY PRACTICABLE

FIGURE 39



b. The velocity error transients are caused by inertial sensor measurement uncertainties, such as scale factor errors and non-orthogonality of sensor axes, and by the receiver oscillator frequency sensitivity to aircraft accelerations. The "g" sensitivity of the receiver oscillator is the largest contributor to the transients. Horizontal and vertical velocity standard deviations of .2 m/sec and .3 m/sec, respectively, characterize the velocity performance over all three simulation runs.

c. In-flight INS alignment was accomplished with an initial heading error of 5 degrees and verticality errors of two (2) degrees. These initial conditions correspond to the errors expected during aircraft maneuvers that may follow an air alignment of the INS.

d. The convergence time for an airborne alignment is approximately six (6) minutes. This is the time it takes the wander angle and verticality errors to converge to four (4) arc minutes and 15 arc seconds (1 sigma), respectively. The verticality mean errors are due to accelerometer biases. The verticality variations about their means contribute to the inertial position and velocity errors. The total verticality error is one part of the INS attitude error. This simulation determined a nominal alignment time for the GPS/Inertial Kalman Filter; however, this alignment time is a function of the aircraft maneuvers so each profile will result in a different convergence time. The steady state wander angle and verticality accuracies are equivalent to the size of these same errors in an INS whose position error drifts with a 1 nm/hr CEP.

e. The transients in the clock drift bias and time errors are caused by the oscillator frequency shifts during aircraft maneuvers. The ten (10) nano-second time error is acceptable.

The simulation results detailed in Tables 3 through 7 summarize the predicted weapon delivery performance for blind delivery of Mark 80 Series ordnance at various dive angles and altitudes. The predicted delivery accuracy varies from roughly 65 feet to 125 feet Circular Error Probable (CEP). These errors approach those achievable with visual target acquisition and release using INS velocity aiding shown in Table 7.

## WEAPON DELIVERY ERROR ANALYSIS

MK 82 BOMB

DIVE ANGLE = 0 DEG

VELOCITY = 500 KNOTS

BLIND

ALTITUDE = 5000 FEET

<u>SOURCE OF ERRORS</u>	<u>ERROR MAGNITUDE</u>	<u>MISS DISTANCE</u>	
		<u>ALONG TRACK (FT)</u>	<u>CROSS TRACK (FT)</u>
<b>BALLISTIC ERRORS</b>			
BOMB DISPERSION (MIL)	3.00	80.64	45.23
EJECTION VELOCITY (FT/SEC)	2.00	45.70	0.0
RELEASE DELAY (SEC)	0.01	8.44	0.0
<b>SENSOR ERRORS</b>			
GROUND TRACK VELOCITY (FT/SEC)	0.66	11.70	11.70
ALTITUDE RATE (FT/SEC)	0.98	23.02	0.0
TRUE AIRSPEED (FT/SEC)	5.00	6.99	0.0
AIRCRAFT POSITION (FT)	29.53	29.53	29.53
ALTITUDE (FT)	45.93	64.60	0.0
<b>ALIGNMENT ERRORS</b>			
<b>PILOT ERRORS</b>			
LATERAL STEERING (DEG)	0.12	0.0	29.62
<b>MISSION PLANNING</b>			
TARGET ALTITUDE (FT)	0.0	0.0	0.0
TARGET POSITION (FT)	0.0	0.0	0.0
BALLISTIC PREDICTION (FT)	5.00	5.00	0.0
ONE-SIGMA DEVIATION (FT)		120.20	62.71

CIRCULAR ERROR PROBABLE (CEP) = 106.27 FEET

CIRCULAR ERROR PROBABLE (CEP) = 3.96 MILS

TABLE 3 - BLIND WEAPON DELIVERY PERFORMANCE STRAIGHT AND LEVEL AT 5000 FEET ALTITUDE

## WEAPON DELIVERY ERROR ANALYSIS

MK 82 BOMB

DIVE ANGLE = -30 DEG

BLIND

VELOCITY = 500 KNOTS

ALTITUDE = 5000 FEET

<u>SOURCE OF ERRORS</u>	<u>ERROR MAGNITUDE</u>	<u>MISS DISTANCE</u>	
		<u>ALONG TRACK (FT)</u>	<u>CROSS TRACK (FT)</u>
<b>BALLISTIC ERRORS</b>			
BOMB DISPERSION (MIL)	3.00	34.58	24.23
EJECTION VELOCITY (FT/SEC)	2.00	23.58	0.0
RELEASE DELAY (SEC)	0.01	3.06	0.0
<b>SENSOR ERRORS</b>			
GROUND TRACK VELOCITY (FT/SEC)	0.66	5.91	5.91
ALTITUDE RATE (FT/SEC)	0.98	8.61	0.0
TRUE AIRSPEED (FT/SEC)	5.00	1.65	0.0
AIRCRAFT POSITION (FT)	29.53	29.53	29.53
ALTITUDE (FT)	45.93	46.23	0.0
<b>ALIGNMENT ERRORS</b>			
<b>PILOT ERRORS</b>			
LATERAL STEERING (DEG)	0.12	0.0	13.18
<b>MISSION PLANNING</b>			
TARGET ALTITUDE (FT)	0.0	0.0	0.0
TARGET POSITION (FT)	0.0	0.0	0.0
BALLISTIC PREDICTION (FT)	5.00	5.00	0.0
ONE-SIGMA DEVIATION (FT)		70.05	40.84

CIRCULAR ERROR PROBABLE (CEP) = 64.65

CIRCULAR ERROR PROBABLE (CEP) = 6.13 MILS

TABLE 4 - BLIND WEAPON DELIVERY PERFORMANCE WITH A 30° DIVE AT 5000 FEET ALTITUDE

## WEAPON DELIVERY ERROR ANALYSIS

MK 82 BOMB

DIVE ANGLE = 0 DEG  
 VELOCITY = 500 KNOTS  
 ALTITUDE = 10000 FEET

BLIND

SOURCE OF ERRORS	ERROR MAGNETUDE	MISS DISTANCE	
		ALONG TRACK (FT)	CROSS TRACK (FT)
<b>BALLISTIC ERRORS</b>			
BOMB DISPERSION (MIL)	3.00	98.68	67.10
EJECTION VELOCITY (FT/SEC)	2.00	44.45	0.0
RELEASE DELAY (SEC)	0.01	8.44	0.0
<b>SENSOR ERRORS</b>			
GROUND TRACK VELOCITY (FT/SEC)	0.66	16.73	16.73
ALTITUDE RATE (FT/SEC)	0.98	22.70	0.0
TRUE AIRSPEED (FT/SEC)	5.00	13.25	0.0
AIRCRAFT POSITION (FT)	29.53	29.53	29.53
ALTITUDE (FT)	45.93	45.18	0.0
<b>ALIGNMENT ERRORS</b>			
<b>PILOT ERRORS</b>			
LATERAL STEERING (DEG)	0.12	0.0	41.66
<b>MISSION PLANNING</b>			
TARGET ALTITUDE (FT)	0.0	0.0	0.0
TARGET POSITION (FT)	0.0	0.0	0.0
BALLISTIC PREDICTION (FT)	5.00	5.00	0.0
ONE-SIGMA DEVIATION (FT)		125.28	85.96
CIRCULAR ERROR PROBABLE (CEP) = 123.72 FEET			
CIRCULAR ERROR PROBABLE (CEP) = 3.70 MILS			

TABLE 5 - BLIND WEAPON DELIVERY PERFORMANCE STRAIGHT AND LEVEL AT 10,000 FEET ALTITUDE

## WEAPON DELIVERY ERROR ANALYSIS

MK 82 BOMB

DIVE ANGLE = -45 DEG  
 VELOCITY = 500 KNOTS  
 ALTITUDE = 10000 FEET

BLIND

SOURCE OF ERRORS	ERROR MAGNETUDE	MISS DISTANCE	
		ALONG TRACK (FT)	CROSS TRACK (FT)
<b>BALLISTIC ERRORS</b>			
BOMB DISPERSION (MIL)	3.00	43.08	37.15
EJECTION VELOCITY (FT/SEC)	2.00	27.16	0.0
RELEASE DELAY (SEC)	0.01	2.54	0.0
<b>SENSOR ERRORS</b>			
GROUND TRACK VELOCITY (FT/SEC)	0.66	8.49	8.49
ALTITUDE RATE (FT/SEC)	0.98	7.07	0.0
TRUE AIRSPEED (FT/SEC)	5.00	4.46	0.0
AIRCRAFT POSITION (FT)	29.53	29.53	29.53
ALTITUDE (FT)	45.93	26.39	0.0
<b>ALIGNMENT ERRORS</b>			
<b>PILOT ERRORS</b>			
LATERAL STEERING (DEG)	0.12	0.0	15.12
<b>MISSION PLANNING</b>			
TARGET ALTITUDE (FT)	0.0	0.0	0.0
TARGET POSITION (FT)	0.0	0.0	0.0
BALLISTIC PREDICTION (FT)	5.00	5.00	0.0
ONE-SIGMA DEVIATION (FT)		65.84	50.52
CIRCULAR ERROR PROBABLE (CEP) = 68.32 FEET			
CIRCULAR ERROR PROBABLE (CEP) = 4.92 MILS			

TABLE 6 - BLIND WEAPON DELIVERY PERFORMANCE WITH A 45° DIVE AT 10,000 FEET ALTITUDE

WEAPON DELIVERY ERROR ANALYSIS

MK 82 BOMB  
BLIND

DIVE ANGLE = -45 DEG  
VELOCITY = 500 KNOTS  
ALTITUDE = 10000 FEET

SOURCE OF ERRORS	ERROR MAGNITUDE	MISS DISTANCE	
		ALONG TRACK (FT)	CROSS TRACK (FT)
<b>BALLISTIC ERRORS</b>			
BOMB DISPERSION (MIL)	3.00	43.08	37.15
EJECTION VELOCITY (FT/SEC)	2.00	27.16	0.0
RELEASE DELAY (SEC)	0.01	2.54	0.0
<b>SENSOR ERRORS</b>			
GROUND TRACK VELOCITY (FT/SEC)	2.50	32.14	32.14
ALTITUDE RATE (FT/SEC)	1.70	12.26	0.0
TRUE AIRSPEED (FT/SEC)	5.00	4.46	0.0
PITCH ATTITUDE (DEG)	0.16	39.72	0.0
HEADING (DEG)	0.16	0.0	21.40
RADAR RANGE (FT)	100.00	12.53	0.0
<b>ALIGNMENT ERRORS</b>			
SIGHT ALIGNMENT (DEG)	0.12	32.07	25.94
RADAR ALIGNMENT (DEG)	0.25	4.98	0.0
<b>PILOT ERRORS</b>			
PILOT AIMING (MIL)	2.00 * 2.00	30.62	24.77
BALLISTIC PREDICTION (FT)	5.00	5.00	0.0
ONE-SIGMA DEVIATION (FT)		86.91	64.48
CIRCULAR ERROR PROBABLE (CEP) = 88.82 FEET			
CIRCULAR ERROR PROBABLE (CEP) = 6.39 MILS			

TABLE 7 - VISUAL WEAPON DELIVERY PERFORMANCE WITH INS VELOCITY

## CHAPTER V - Conclusions and Recommendations

There are numerous benefits that can be obtained by integrating the NAVSTAR/Global positioning User equipment with a current technology digital avionics system. These include:

- a. Standardization in Positioning Systems
- b. Improved positioning and navigation accuracy
- c. Interoperability by utilizing all friendly forces
- d. Improved reliability/supportability
- e. Improved survivability and anti-jamming capability

Unfortunately these capabilities alone will not directly improve the effectiveness of an air vehicle in accomplishing the close air support mission. This results from the inability of the ground forces to identify their location with sufficient accuracy and thus the targets location to take advantage of the improved blind bombing capability achievable by an integrated system.

However, if the aircraft equipped with an integrated NAVSTAR/GPS Digital Avionics System is fielded along with the NAVSTAR/GPS Manpack receiver, a significant operational improvement will result. For example, a ground based forward air controller could use the manpack to determine precisely his and other friendly forces positions. This plus a range finder and compass could be used to accurately determine the location of a specific target which could then be radioed to the attack aircraft. This data would then aide the aircrew in acquiring the target visually, thus increasing the probability of kill on the first pass. Further, the synergistic effects of the ground based and airborne segments of the NAVSTAR/GPS system will allow the blind delivery of Mark 80 Series bombs, or similar ordnance against relatively soft targets. This could be accomplished during marginal weather, at night, or in a high threat area. For targets such as tanks or armored personnel carriers, cluster munitions could be applied with a high degree of effectiveness, again without visual identification. All of the above can be accomplished with a single pass thus minimizing the aircraft's exposure to hostile fire, with an attendant reduction in aircraft attrition.

It is recommended that any interested country consider the implementation of the airborne and ground segments of the NAVSTAR/GPS simultaneously.

**APPENDIX A - Draft Specification for an Integrated NAVSTAR/GPS Digital Avionics System****PREFACE**

This draft specification defines the basic system architecture and interfaces for an Integrated NAVSTAR/GPS Digital Avionics System. Other areas, such as non-GPS aided weapon capability, reliability, etc., are identified but not discussed. Thus, this draft specification can serve as a point of departure in preparing a definitive specification for a particular mission. Specific numerical requirements are left blank, thus allowing the user to tailor the system to meet specific operational needs.

TABLE OF CONTENTS

<u>Section</u>		<u>Page</u>
1.0	SCOPE	
1.1	Definition	A-1
2.0	APPLICABLE DOCUMENTS	A-1
2.1	Government Documents	A-1
3.0	REQUIREMENTS	A-3
3.1	System Description	A-3
3.1.1	General System Description	A-3
3.1.2	System Missions	A-5
3.1.3	System Diagram	A-5
3.1.4	Interface Definition	A-5
3.2	Characteristics	A-6
3.2.1	Performance Characteristics	A-6
3.2.2	Physical Characteristics	A-7
3.2.3	Reliability	A-7
3.2.4	Maintainability	A-7
3.2.5	Environmental Requirements	A-7
3.2.6	Nuclear Control Requirements	A-9
3.2.7	Transportability	A-9
3.3	Design and Construction	A-9
3.3.1	Materials, Processes and Parts	A-9
3.3.2	Electromagnetic Interference	A-9
3.3.3	Nameplates and Product Marking	A-9
3.3.4	Workmanship	A-9
3.3.5	Interchangeability	A-9
3.3.6	Safety	A-9
3.3.7	Human Engineering	A-9
3.3.8	Thermal	A-10
3.3.9	Interconnecting Cabling	A-10
3.3.10	Maintenance Provisions	A-10
3.4	Documentation	A-11
3.5	Logistics	A-11
3.5.1	Maintenance	A-11
3.5.2	Facilities and Equipment	A-11
3.6	Functional Area Characteristics	A-11
3.6.1	Navigation Functional Area	A-11
3.6.2	Weapon Delivery	A-20
3.6.3	Steering	A-24

## TABLE OF CONTENTS (Cont'd)

<u>Section</u>		<u>Page</u>
3.6.4	Sensor Cueing	A-24
3.6.5	Control and Display	A-25
3.6.6	Built-In-Test (BIT)	A-28
4.0	QUALITY ASSURANCE PROVISIONS	A-29
4.1	Responsibility for Inspection	A-29
4.2	Quality Assurance	A-29
4.3	Classification of Tests	A-29
4.4	Test Conditions	A-29
4.5	Performance Tests	A-29
4.6	Simulator Tests	A-29
4.7	Flight Tests	A-29
5.0	PREPARATION FOR DELIVERY	A-29
6.0	NOTES	A-29

## LIST OF FIGURES

<u>Figure</u>		<u>Page</u>
1	Integrated NAVSTAR/GPS Avionics System Functional Diagram	A-3
2	Interfaces with Systems External to the Integrated NAVSTAR/GPS Digital Avionics System	A-6
3	Integrated NAVSTAR/GPS Digital Avionics System Functional Areas Interface	A-7
4	Integrated GPS/Inertial Block Diagram	A-13
5	GPS with Inertial Aiding Block Diagram	A-14
6	Pictorial Representation of GPS Blind Bombing Mode	A-21
7	Pictorial Representation of the Dive Toss Mode	A-23

## LIST OF TABLES

<u>Table</u>		<u>Page</u>
1	Free Inertial Accuracy and Times	A-15
2	ESP and J/S Conditions	A-17
3	TTF and Simultaneous Conditions	A-18
4	Reacquisition	A-19
5	J/S Margins	A-19
6	User Vehicle Dynamics	A-20
7	Pseudo Range and Pseudo Rate Measurement Accuracy	A-20
8	Digital Display Indicator	A-26
9	System Flight Instrument Outputs, Resolutions, and Characteristics	A-26

## 1.0 SCOPE

1.1 Definition. This specification establishes the performance, configuration, and test requirements for the Integrated NAVSTAR/GPS Digital Avionics System, integrated with a NAVSTAR/Global Positioning System (GPS) receiver.

## 2.0 APPLICABLE DOCUMENTS.

2.1 Government Documents. The following documents form a part of this specification to the extent specified herein. Unless otherwise indicated the issue in effect on the date of contract award shall apply. In the event of a conflict between this specification and the documents referenced herein, this specification shall govern.

Precedence

The order of precedence of applicable documents including this specification shall be as specified in the contract.

SPECIFICATIONSMilitary

MIL-E-5400	Electronics Equipment, Airborne, General Specification for
MIL-C-6781	Control Panel: Aircraft Equipment, Rack of Console Mounted
MIL-P-7788	Panels, Information, Integrally Illuminated

Other Government Specifications

SS-GPS-300A	System Specification for the NAVSTAR Global
SS-US-200	System Segment Specification for the User System Segment NAVSTAR Global Positioning System Phase II

STANDARDS:Military

MIL-STD-130	Identification Marking of US Military Property
MIL-STD-411	Aircrew Station Signals
MIL-STD-461	Electromagnetic Interference Characteristics Requirements for Equipment
MIL-STD-462	Electromagnetic Interference Characteristics, Measurement of
MIL-STD-471	Maintainability Demonstration
MIL-STD-781	Reliability Design Qualification and Production Acceptance Tests: Exponential Distribution
MIL-STD-785	Reliability Program for Systems and Equipment Development and Production
MIL-STD-794	Parts and Equipment, Procedures for Packaging and Packing of

MIL-STD-810 Environmental Test Methods

MIL-STD-1553 Aircraft Internal Time Division Command/Response Multiplex Data Bus

HANDBOOKS:

MIL-HDBK-217 Reliability Stress and Failure Rate Data for Electronic Equipment

RADC TR-67-108 RADC Reliability Notebook AD-845304, AD-821640

## 3.0 REQUIREMENTS

3.1 System Description. The Integrated NAVSTAR/GPS Digital Avionics System (herein referred to as the System) shall provide an integrated Navigation and Weapon Delivery capability. The System as a minimum shall be comprised of the following:

1. Central Processor (CP)
2. Keyboard and Rotary Function Switches
3. Digital Display Indicator
4. Auxiliary Digital Display (For back seat of "Two Seat" fighter application)
5. NAVSTAR/GPS Receiver Set
6. Inertial Navigation System (INS)
7. Power Supply

3.1.1 General System Description. The system shall provide weapon delivery, navigation, steering, and sensor management capabilities. The Central Processor shall combine signals from the Inertial Navigation System, the GPS Receiver Set, and other navigation aids utilizing Kalman Filter techniques to provide best estimates of three-dimensional position, velocity, and time. Mission related information such as destination latitude, longitude and elevation, weapon identifiers, release advance, spacing, etc., shall be inserted through the keyboard. System navigation data, steering data, and other related information shall be displayed on the Digital Display Indicator (and the Auxiliary Digital Indicator for "Two Seat" fighter application) by using the keyboard in an interactive mode of operation. Weapon delivery signals and sensor cueing commands shall be controlled by the Central Processor. The system shall provide these capabilities by executing the six major functions shown in Figure 1 and described below.

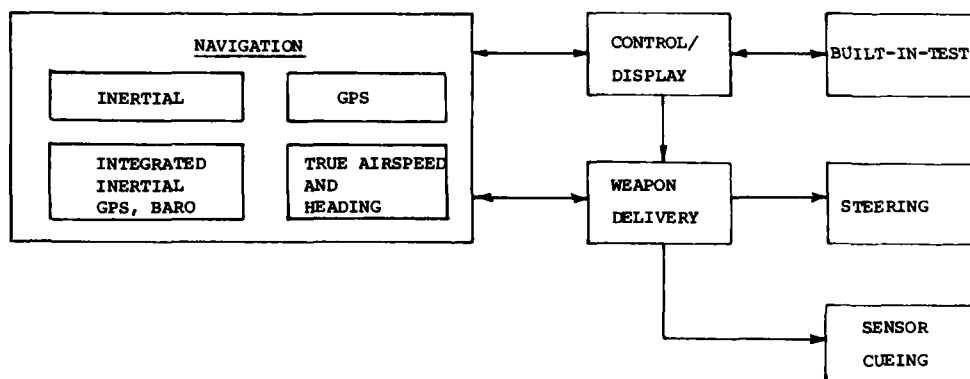

FIGURE 1 - INTEGRATED NAVSTAR/GPS DIGITAL AVIONICS SYSTEM FUNCTIONAL DIAGRAM

3.1.1.1 Navigation. The Navigation Function shall consist of one primary and four back-up mode of navigation. The prime navigation mode shall be the Integrated GPS-Inertial wherein GPS and inertial measurements are combined in an optimal manner. The back-up modes shall be operator selectable. In the event the primary mode fails the highest priority back-up mode shall be automatically selected. The mode priorities shall be as follows:

- a. Integrated GPS-Inertial (primary)
- b. GPS with Inertial Velocity Aiding
- c. Inertial Only
- d. GPS Only
- f. True Airspeed and Heading

When valid GPS information is available, the Navigation Function shall convert it into system time and three-dimensional position and velocity in WGS-72 coordinates. Worldwide navigation capability (including polar regions) shall be provided as well as Ground Calibration, Gyrocompass Alignment, Best Available True Heading (BATH) Alignment, and In-Flight Inertial alignment capability.

3.1.1.2 Weapon Delivery. The Weapon Delivery Function shall provide computed release signals for visual and blind air-to-ground weapon delivery modes. The weapon delivery solution shall compensate for ejection velocity and rack delay. The ballistic equations shall cover all air-to-ground weapon release envelopes. Multiple releases shall be generated to give weapon spacing on the ground in feet, accounting for speed and flight profile.

3.1.1.3 Steering. The Steering Function shall provide steering commands based on aircraft position and velocity relative to an operator selected flight path. These commands shall be provided to both the Automatic Flight Control System (AFCS) and to the pilot via aircraft instruments. Automatic sequencing of steering shall be provided only when the landing approach mode has been selected.

3.1.1.4 Sensor Cueing. The System shall as a minimum provide cueing and pointing commands for the following sensors:

- a) Radar
- b) Electro-optical system(s).

The above sensors shall be individually selectable or cued in a coordinated manner to operator selected position coordinates.

Pointing angles for cueing shall be computed from the aircraft position and altitude and preselected target coordinates. Offset targetting shall be provided using aircraft position, sensor pointing angles and the best available range information.

3.1.1.5 Control/Display. The Control/Display Function shall provide the human interface for the System and shall consist of a keyboard and rotary function switches, the Digital Display Indicator, the Auxiliary Digital Display Indicator (for "Two Seat" fighter application) and the Control/Display software within the Central Processor. The functions provided by the Control/Display Function shall include the following:

- a. System mode selection
- b. Operator data insertion
- c. System data display
- d. System status annunciators

3.1.1.6 Built-In-Test (BIT). The System shall contain built-in-test provisions to allow fault isolation to every system LRU. An in-line BIT function shall provide continuous monitoring of system operational status during flight. A more extensive ground BIT shall also be provided.

3.1.2 System Missions. The System shall provide the following mission capabilities:

This mission capability shall include point-to-point navigation to destinations or targets inserted or computed.

For weapon delivery missions the following modes of air-to-ground release shall be allowed:

- a. Blind (using the navigation system)
- b. Sensor Blind
- c. Dive Toss
- d. Continuously Computed Impact Point

The aircraft commander shall not be restricted to fly a predetermined altitude or airspeed nor shall he be required to maintain vertical velocity at zero (uncanned flight conditions at release). The aircraft commander or weapon system officer shall be allowed to designate targets using available sensors.

The System shall provide the steering information relative to destinations based upon fixed course or direct track, as determined by the operator. Steering to a touchdown point along a preselected course shall also be provided in the landing approach mode. Sensor cueing to selected target coordinates shall be provided, as well as offset targeting to update target coordinates, based on sensor pointing angles and ranging data.

Typical mission duration shall be \_\_ hours (\_\_hours with in-flight refueling). Performance shall be maintained throughout the high dynamic conditions specified in paragraph 3.6.1.5.2.3.9.

3.1.3 System Diagram. TBD

3.1.4 Interface Definition.

3.1.4.1 Interface With Other Systems. This section defines the interface between the System and the other aircraft hardware.

3.1.4.1.1 Detailed Interface Definition. The detailed interfaces between the CP and the equipment with which it interfaces in accomplishing its primary tasks, are described in the following paragraphs. All digital interfaces shall be in accordance with MIL-STD-1553.

3.1.4.1.2 Functional Interfaces With External Subsystems. Figure 2 shows the functional interfaces between the System and other identified subsystems.

a. Radar. The radar shall be used to determine slant range in the air-to-ground modes. The System shall provide cursor control for target location and shall point the radar antenna as required by the Sensor Cueing Function.

b. Heads Up Displays. The Heads Up Display (HUD) shall use azimuth and elevation commands from the System to drive the sight and point as required by the Sensor Cueing Function. In addition, the roll index reticle of the HUD shall provide lateral steering to destination or weapon release points.

c. Central Air Data Computer. The Central Air Data Computer (CADC) shall provide angle of attack, barometric altitude, and true airspeed to the System.

d. Flight Instruments. The flight instruments shall include the HSI and the ADI. Navigation and steering information shall be supplied to these instruments by the System.

e. Flight Director Computer. The flight director computer shall receive drift angle and relative bearing from the System.

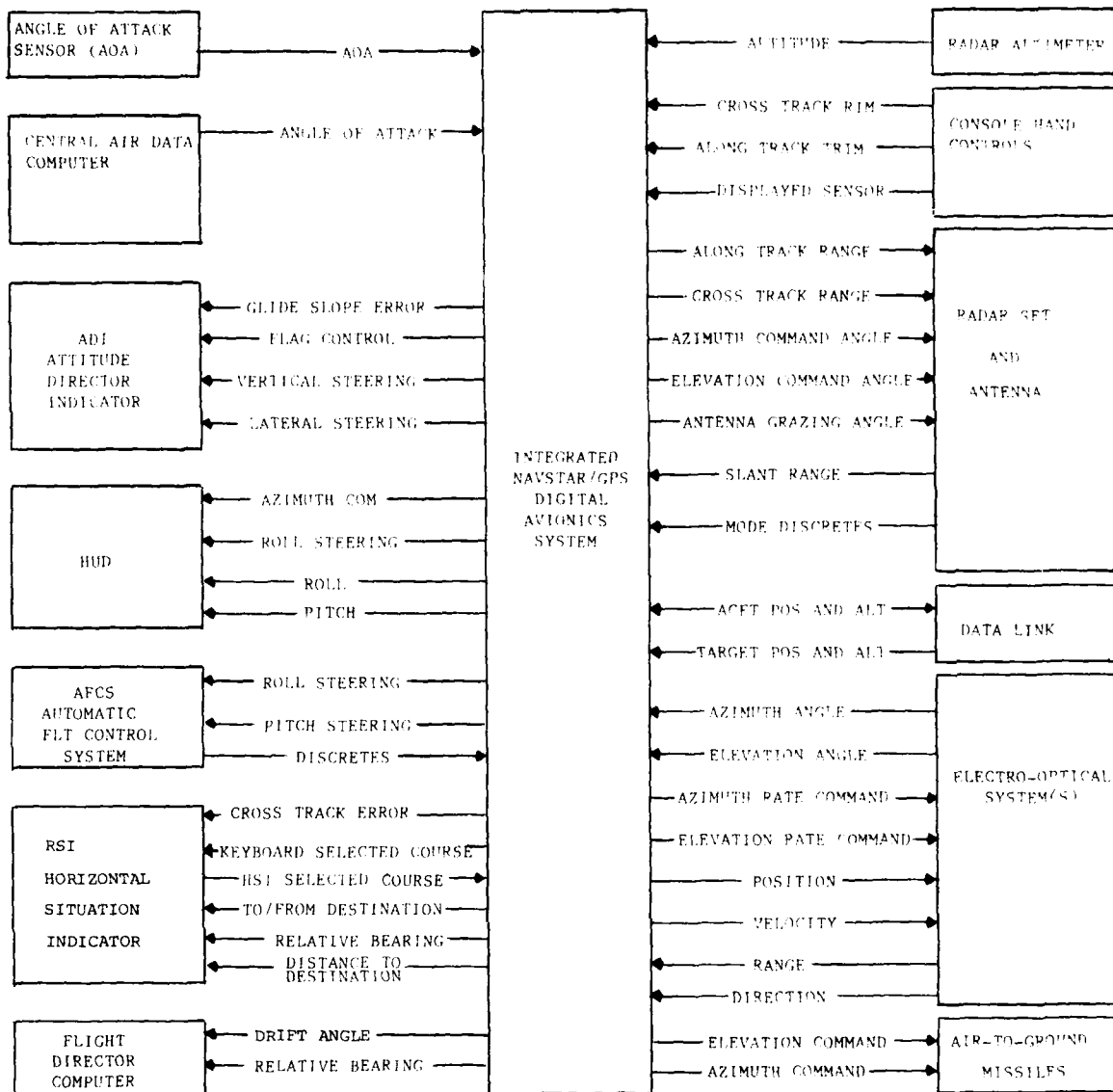

FIGURE 2 INTERFACES WITH SYSTEMS EXTERNAL TO THE INTEGRATED NAVSTAR/GPS DIGITAL AVIONICS SYSTEM

f. **Weapon Release Circuitry.** The System shall provide air-to-ground weapon release signals. Signals to the annunciators, the intervalometer, and the indexer lights shall be included.

g. **Console Hand Controls.** The trim controls shall supply along-track and cross-track trim rates to the System and other devices. The System shall associate trim rates with displayed sensors in order to generate the required cue commands.

3.1.4.2 **Functional Areas Interface.** The interfaces for the various functional areas shall be as shown in Figure 3. A detailed description of the characteristics of each system function is given in paragraph 3.6.

### 3.2 Characteristics.

3.2.1 **Performance Characteristics.** The System performance in the areas of navigation, blind weapon delivery and approach to landing shall be as specified herein.

3.2.1.1 **Navigation Performance.** The navigation function shall provide position, velocity, heading, and altitude information outputs at a \_\_\_ millisecond rate. The System shall normally operate in the integrated GPS/INS prime navigation mode.

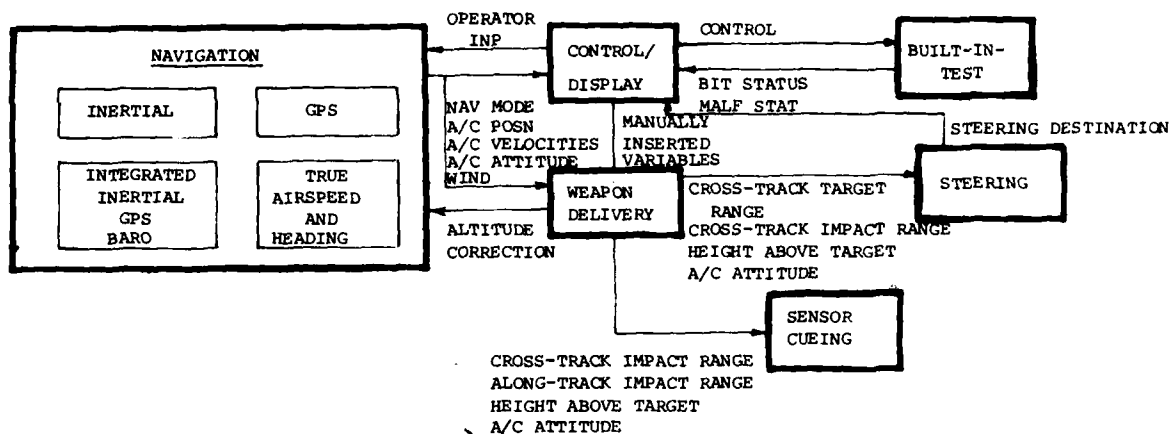

FIGURE 3 - INTEGRATED NAVSTAR/GPS DIGITAL AVIONICS SYSTEM FUNCTIONAL AREAS INTERFACE

Horizontal Position Accuracy: TBD

Vertical Position Accuracy: TBD

Velocity Accuracy: TBD

The System shall achieve the above performance under the dynamic and jammer-to-signal conditions specified in 3.6.1.5.2.3.9 and 3.6.1.5.2.3.7, respectively.

3.2.1.2 Weapon Delivery Performance. TBD

3.2.1.2.1 GPS Blind Mode. The performance in the GPS blind mode shall be consistent with the accuracy of the aircraft position and velocity as described in paragraph 3.6.1.

3.2.2 Physical Characteristics. TBD

3.2.3 Reliability. TBD

3.2.4 Maintainability. TBD

3.2.5 Environmental Requirements.

3.2.5.1 GPS Receiver Set and GPS Pre-Amp Assembly. The GPS Receiver Set and the GPS Pre-Amp Assembly of the System shall meet the environmental requirements of their respective specifications.

3.2.5.2 The System Less GPS Pre-Amp Assembly and Receiver Set. All System equipment less the GPS Receiver shall meet the following environmental requirements. These are summarized below:

- a. Altitude. TBD
- b. Temperature. TBD
- c. Temperature Shock. TBD
- d. Temperature - Altitude. TBD

- e. Humidity. TBD
- f. Explosive Conditions. TBD
- g. Acceleration. TBD
- h. Vibration. TBD
- i. Acoustical Noise. TBD
- j. Shock. TBD

3.2.6 Nuclear Control Requirements. TBD

3.2.7 Transportability. The System shall not require any special equipment for transportability due to component (LRU) size and operational characteristics.

3.3 Design and Construction. System flexibility (adaptability) shall be optimized through modularity to the maximum extent possible system.

3.3.1 Materials Processes and Parts.

3.3.1.1 Approval of Non-standard Materials. TBD

3.3.1.2 Reliability Design. TBD

3.3.1.3 Wiring. Wiring installed in elastomeric environment wire seal connectors shall be within the range of insulation diameters specified as acceptable in the connector specification.

3.3.1.4 Polarization. TBD

3.3.1.5 Cases and Front Panels. Finish of equipment installed in other than the cockpit area shall be a lusterless black color.

3.3.2 Electromagnetic Interference. The individual units of the System shall be designed to meet and comply with the applicable test methods of MIL-STD-462 when tested as individual units and a complete system in accordance with the test limits of MIL-STD-461 for Class A equipment.

3.3.3 Nameplates and Product Marking. The individual units shall be identified by nameplates. All requirements pertaining to nameplates shall be marked in accordance with applicable specifications (e.g., MIL-STD-130), drawings, or standards.

3.3.4 Workmanship. Workmanship shall be in accordance with MIL-E-5400.

3.3.5 Interchangeability. The System shall incorporate a modular design to the greatest extent possible.

3.3.6 Safety. TBD

3.3.7 Human Engineering. The System shall be equipped with a digital display, software programs, and an appropriate control/display and keyboard to permit the System to transmit abbreviated alphanumeric cues to the operator so as to indicate what data is being displayed and a cue as to what data is required to be loaded via the keyboard. The keyboard shall be a full alphanumeric keyboard with provision for entering English alpha characters and 10 decimal characters (0 through 9) as well as (+) and (-). A skip or advance key shall be provided to sequence through a major category or list of desired displays or required parameters. The various major categories shall be switched via a conventional rotary switch(s). The quantity and number of positions of rotary switches shall be minimized. The selectable categories shall include:

a. Coordinates

- (1) UTM
- (2) LAT/LON

b. Data

- (1) Flight
- (2) Cue
- (3) Mission
- (4) Destination
- (5) GPS
- (6) Cal/Test

c. Steer

- (1) Automatic Nav
- (2) Manual Nav
- (3) Offset or Freeze

d. A set of priority keys shall be provided which override any sequence in the "FLIGHT" category. These keys shall consist of the following as a minimum.

- (1) Present Position (coordinates)
- (2) Ground Track, Ground Speed, Bearing, Range, Cross-Track Error, Along-Track Distance, Course, Estimated time in Route, Heading, True Airspeed, Altitude, Vertical Velocity, Wind Direction, Wind Velocity, Magnetic Variation, Variation Synchronization, Glide Path Error, Glide Path, Time of Day, Mission Mode, Fly/Cue.

e. Keys may be dual purpose with no more than two functions assigned to one key except for the (-) negative key which may serve no more than three functions.

3.3.7.1 Controls and Indicators. TBD

3.3.7.1.1 Panel Lighting. TBD

3.3.7.2 Dynamic Display. The controls and indicators shall provide alphanumeric displays suitable for display of the data specified in section 3.7. The alphanumeric display shall provide the performance specified herein.

3.3.7.2.1 Display Update Rate. The dynamic information required for display shall be updated at least one per second unless the display is in the FRZ mode.

3.3.7.3 Readability. To ensure readability of the dynamic information depicted by the alphanumerics, the following minimum requirements shall be satisfied.

3.3.7.3.1 Brightness, Contrast, and Control. In direct sunlight the readability of the alphanumerics shall not be less than a quotient of \_\_\_ for the case where the numerator consists of the element brightness less the background brightness and the denominator is the background brightness when the ambient brightness is \_\_\_ foot-lamberts (ft-L). To accommodate the decreasing ambient levels of daytime conditions into and including those of night time, a dimming control shall be included. This control shall also be capable of dimming the display down continuously to \_\_\_ foot-lamberts. All alphanumeric displays shall have a non-reflective coating on the surface to minimize reflections from outside light.

3.3.7.3.2 Uniformity. The brightness uniformity of the alphanumeric display shall be such that nonuniformity between adjacent lighted numerals, between adjacent lighted elements and within any element do not exceed a ratio of \_\_\_ to 1 at rated lamp voltage. (Rated voltage defined as maximum design lamp voltage.)

3.3.7.3.3 Display Color. TBD

3.3.7.3.4 Resolution. The resolution of the display shall be such that it gives the appearance of clarity without ambiguity at viewing distances up to \_\_\_ inches. Parallax shall not be evident at these same viewing distances at angles up to \_\_\_ degrees.

3.3.7.4 Dimming Requirements. The brightness of the light signal shall meet the requirements of 3.3.7.3.1. Control and indicator mounted advisory lights shall be dimmed continuously from the maximum brightness to \_\_\_ foot-lamberts and below via the same control panel mounted dimmer control used for the alphanumeric displays. The advisory lights, when not energized, shall not appear to be energized in sunlight. The brightness ratio between the advisory lights and the alphanumeric displays shall not exceed \_\_\_ to 1.

3.3.7.5 Environmental Considerations. There shall be no discernible jitter of the display under the environmental conditions specified in MIL-STD-810.

3.3.7.6 Advisory Displays. The controls and indicators shall visually display the status of the following parameters. The requirements of MIL-STD-411 apply except for the dimming requirements therein. Bulbs, if utilized, shall be front replaceable.

- a. System malfunction
- b. Number of GPS transmitters being used in the NAV solution and the one sigma uncertainty of the NAV performance.
- c. A "NO GPS" indication to extinguish upon completion of search and settle and transition to track.
- d. An announcement of transition from Integrated GPS-Inertial guidance to backup mode.
- e. NO DATA. The NO DATA indicator shall illuminate whenever data required for proper functioning of the System is not present.
- f. All operator selected actions (such as data insert of selected displays) shall be visually announced.
- g. Inertial/GPS status.
- h. GPS receiver malfunction.
- i. INS malfunction.
- j. Weapon release function.
- k. Align status:
  - (1) Continuous for in process, or to indicate switch to ATTD
  - (2) Not illuminated, if gyrocompass complete

3.3.8 Thermal. The System shall incorporate thermal protection which will shut down the equipment should critical temperature limits be exceeded.

3.3.9 Interconnecting Cabling. All individual units of the System, exclusive of the Antenna Coupler, shall be capable of accommodating from one to 35 feet of interconnecting cabling between units. Signal circuit wires shall not be smaller than size \_\_\_ or larger than size \_\_\_ per MIL-E-5400.

3.3.10 Maintenance Provisions. The maintainability concept and support aspects of the System, less the GPS Receiver, shall include the following:

- a. The System shall include an indication to the operator when the System is not functioning satisfactorily.
- b. The System shall have a built-in go/no-go test capability to allow fault isolation to each Line Replaceable Unit (LRU).
- c. Each LRU of the System, when removed from the aircraft, shall be responsive to either a built-in or external test capability for the purpose of isolating a fault to a particular module within the unit.
- d. Each LRU of the System with a predicted MTBF of less than 10,000 hours shall include an elapsed time indicator to record operating time.
- e. A fixed interface shall exist when LRU's are installed in the aircraft system (i.e., no adjustments necessary).

3.4 Documentation. TBD

3.5 Logistics.

3.5.1 Maintenance. TBD

3.5.2 Facilities and Equipment. TBD

3.6 Functional Area Characteristics. The System shall have six functional areas: navigation, weapon delivery, steering, sensor cueing, control display and built-in-test. The characteristics of the six functional areas shall be as specified in the following sections.

3.6.1 Navigation Functional Area. The navigation functional area shall provide the aircraft 3-dimensional position, velocity and heading for use by all other system functional areas. These outputs shall be referenced to the geodetic latitude, longitude and altitude of WGS-72 ellipsoid or to the UTM coordinates of the following selectable spheroid models.

- a. International
- b. Airy
- c. Hough
- d. Clark 1866
- e. Clark 1880
- f. Everest
- g. Bessel
- h. Australian National
- i. South American

The data used to obtain the navigation outputs shall be:

1. Pseudo range and pseudo range rate for satellites provided by the GPS receiver.
2. 3-dimensional acceleration components, roll, pitch, and azimuth signals provided by the Inertial Navigation System (INS).
3. Barometric Altitude and True Airspeed from the Central Air Data Computer (CADC)

#### 4. Aircraft heading and pitch from the Attitude and Heading Reference System.

The above sensor data is processed in the navigation functional area to provide aircraft position, velocity and heading outputs by the following five navigation modes:

##### 1. Integrated GPS/Inertial Mode

The GPS receiver pseudo range and pseudo range rate measurement shall be combined in an optimum manner with the position and velocity measurements provided by the Inertial Navigation System (INS) using a Kalman Filtering technique (an optimal data processing technique). Besides 3-dimensional position, velocity and heading, this mode shall provide roll, pitch, and GPS time. The Kalman Filter shall also provide an in-flight INS alignment capability. Velocity aiding for the GPS receiver shall be provided by the INS.

##### 2. GPS with Inertial Aiding Mode

The 3-dimensional position and velocity shall be determined by coordinate conversion of the GPS pseudo range and range rate measurements. The INS shall provide heading, roll and pitch outputs, and velocity aiding signals to the GPS receiver.

##### 3. Inertial Only Mode

The position, velocity, heading, and attitude shall be provided by the INS. The barometric altimeter measurements shall be used for vertical channel (altitude and vertical velocity) damping.

##### 4. GPS Only Mode

The position and velocity outputs shall be determined by coordinate conversion of the GPS pseudo range and range rate measurements.

##### 5. True Airspeed and Heading Mode

The north and east velocities shall be determined by resolving the True Airspeed (TAS) into north and east components using the aircraft pitch and magnetic compass heading corrected with magnetic variation tables. The latitude and longitude outputs shall be computed by integrating the velocity solutions. Altitude shall be provided by the barometric altimeter.

The operational navigation mode shall be selected by the operator. However, if the sensor information required for the selected mode is not valid, then the navigation functional area shall automatically select the next highest priority available mode and provide navigation outputs from that mode to the other functional areas. The navigation modes are prioritized in the order listed above.

**3.6.1.1 Integrated GPS/Inertial (Prime) Mode.** For the Integrated GPS/Inertial Mode, data from the system's GPS receiver and Inertial Navigation System shall be combined, in an optimal manner, to provide integrated solutions of aircraft 3-dimensional position, 3-dimensional velocity, heading and time. An optimal Kalman Filter shall process the GPS and inertial measurements using the short term accuracy of the inertial measurements and the long term accuracy of the GPS measurements to provide, at a minimum, Position, velocity and heading performance that is an improvement over the navigation performance obtainable from either sensor alone.

The GPS/Inertial Kalman Filter shall estimate errors in the INS's position, velocity, heading and verticality. The Kalman Filter shall add the error estimates to the INS navigation outputs to provide the prime mode outputs.

By processing GPS data the Kalman filter shall be capable of aligning the INS, from a cold start, in-flight.

Figure 4 is a block diagram of the integrated GPS/inertial mode.

The GPS receiver shall supply to the GPS/Inertial Kalman Filter pseudo ranges, pseudo range rates, the time of their measurement, signal-to-noise ratios for each satellite signal and measurement status indicators. The INS shall supply to the Kalman Filter position, velocity, heading and attitude information.



The satellite clock correction algorithm and satellite ephemeris algorithm shall be used in the receiver measurement correction and range and range rate prediction processes, respectively. The ionospheric delay correction shall be made using direct measurements of pseudo range at the  $L_1$  and  $L_2$  frequencies. The range prediction calculations shall include a correction for the antenna center - inertial sensor cluster displacement.

3.6.1.1.1 Integrated GPS/Inertial performance. The GPS receiver performance is specified in detail in 3.6.5.2.3. With an assumed Horizontal Dilution of Precision (HDOP) of 1.5 and assumed Vertical Dilution of Precision (VDOP) of 2.5, the integrated GPS/Inertial performance shall be:

- Horizontal Position Error = TBD
- Vertical Position Error = TBD
- Velocity Error = TBD

The altitude and heading accuracies shall be equal to or better than autonomous INS. For in-flight INS alignment the GPS/Inertial Kalman Filter shall align the system with sufficient accuracy for an autonomous navigation accuracy of better than     nautical miles per hour CEP. This performance shall be achievable when the INS starts with heading errors no greater than     degrees. Alignment shall be completed in     minutes.

3.6.1.2 GPS with Inertial Aiding Mode. A selectable navigation mode shall be provided where the GPS pseudo ranges and pseudo range rates are system converted into solutions for three-dimensional position, velocity, GPS time and clock drift. The long-term velocity solutions shall be used as corrections for the INS velocities. In this mode, velocity aiding signals shall be supplied to the GPS receiver a minimum of 50 times/sec using INS measurements.

The interfaces between the GPS receiver and INS are shown in Figure 5. The GPS receiver shall supply four pseudo ranges, four pseudo range rates, the measurement time, and status indicators for each measurement. The pseudo range measurements shall be provided a minimum of     times/sec and the range rate measurements during the interval between the range measurements. The INS and GPS measurements shall be valid at the same time to within     milliseconds.

The coordinate conversion technique shall use the GPS measurement correction techniques and satellite ephemeris specified for the integrated GPS/Inertial navigation mode (3.6.1.1). The coordinate converter shall provide position and velocity outputs every     milliseconds. The INS velocities shall be used for the update of the position every     milliseconds.

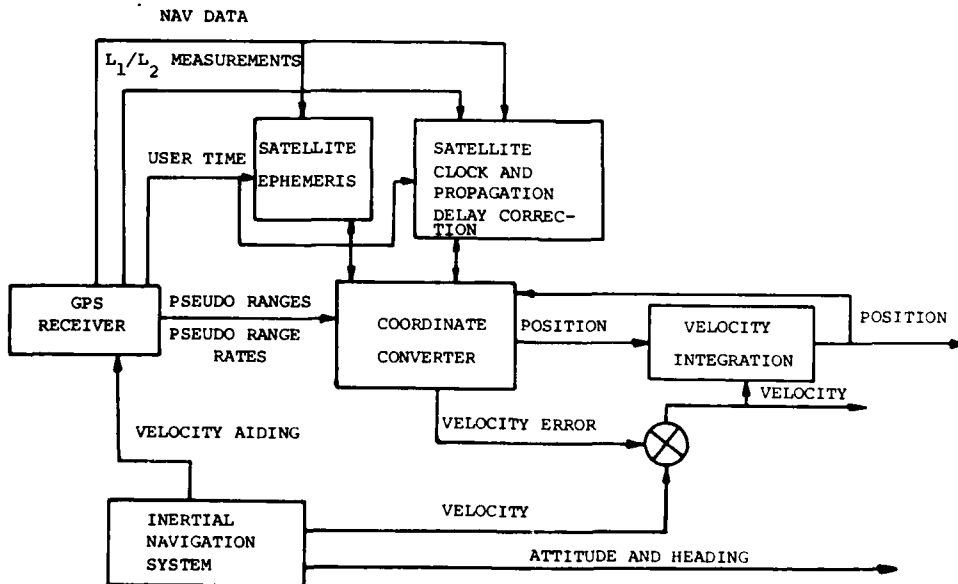

FIGURE 5 GPS WITH INERTIAL AIDING BLOCK DIAGRAM

3.6.1.2.1 GPS with Inertial Aiding Performance. Under the aircraft dynamics in Table 6 and J/S: \_\_\_ dB, the GPS with Inertial Aiding Mode performance shall be:

Horizontal Position Error = TBD

Vertical Position Error = TBD

Velocity Error = TBD

3.6.1.3 Inertial Only Mode. The System shall be capable of operating as an autonomous Inertial Navigation System. In this mode, the three accelerometer outputs of the Inertial Navigation Set (INS) and the barometric altitude measurements shall be processed in the Central Processor to obtain the geodetic position, the north, east and vertical velocity components, and altitude. A baro-inertial mechanization shall be used for vertical velocity and altitude computations, while a world wide inertial navigation mechanization shall be employed for determining latitude, longitude, platform wander angle, and the level components of velocity. The inertial azimuth gimbal resolver output shall be combined with the platform wander angle to provide the true heading angle.

3.6.1.3.1 Alignment. The INS shall provide navigation outputs for the Inertial Only Mode after one of three initialization (alignment) techniques: gyrocompass alignment, rapid reaction alignment, and inflight alignment with GPS.

3.6.1.3.1.1 Gyrocompass Alignment. Gyrocompass alignment shall provide azimuth and level alignment with sufficient accuracy so as to provide the navigational accuracy specified in Table 1 with warm-up time and temperatures as specified therein for latitudes of less than 70 degrees. A wide-angle gyrocompass technique shall be used to establish an adequate initial heading for gyrocompass alignment, if the initial heading error is too large to allow gyrocompass alignment convergence.

3.6.1.3.1.2 Rapid Alignment. Rapid alignment shall be divided into BATH Alignment and Stored Heading Alignment submodes. Conditions which dictate which type of rapid reaction alignment is activated are as follows:

TABLE 1 Free Inertial Accuracy and Times

PARAMETER	ALIGNMENT MODE		
	GYROCOMPASS	STORED HEADING	BATH
(3 Sigma except as noted)			
1. Warm-up and Align Time 70° F	8 min	1.5 min	1.5 min
2. Warm-up and Align Time 0° F	9 min	2 min	2.0 min
3. Warm-up and Align Time -40° F	12 min	2 min	2.0 min
4. Present Position	.8 nm/hr	3 nm/hr CEP	___*
5. N/S velocity	2.5 RMS	5.0 RMS	___*
6. E/W velocity	2.5 RMS	5.0 RMS	___*
7. Vertical velocity	2.0 RMS	3.0 RMS	___*

\*Dependent on quality of heading input

(a) Stored heading alignment

- (1) Stored heading alignment shall be activated when, at initial start-up, the measured difference between the stored value of true heading (from the previous turn on) and presently measured heading (magnetic heading input plus manually entered magnetic variation) is less than \_\_\_ degrees delta angle.
- (2) Navigation accuracy after start-up, under stored heading conditions, shall be as specified in Table 1. Within three minutes of start-up at 0° for latitudes of less than 70°, and with the provision that a full gyrocompass alignment has been performed immediately prior to the previous system shutdown and the aircraft has not been moved since that shutdown, the stored heading accuracies of Table 1 shall apply.

(b) BATH alignment

- (1) BATH (Best Available True Heading) alignment shall be activated when the measured difference between the stored value of true heading (from the previous turn-on) and presently measured true heading (magnetic heading input plus manually entered magnetic variation) is more than \_\_\_ degrees. This shall permit the system to be aligned rapidly without limiting aircraft movement prior to alignment.
- (2) Assuming true heading (magnetic heading input plus keyboard variation) to be accurate to \_\_\_ degrees, the system shall meet the navigation accuracy specified in Table 1 for latitudes less than 70°.

3.6.1.3.1.3 In-flight INS Alignment. While airborne, the system shall have the capability to (1) start the INS, (2) process the INS's X and Y accelerometers outputs and the true airspeed and magnetic heading to establish a level platform, and (3) using the GPS/inertial Kalman Filter, align the INS to provide better than a \_\_\_ nautical mile per hour CEP performance (see 3.6.1.1.1).

3.6.1.3.2 Inertial Navigation. After alignment is completed, the system shall solve the navigation problems by sensing acceleration, applying appropriate torques, and determining aircraft velocity and position using the WGS-72 earth model. The system shall provide the navigation accuracy specified in Table 1.

The system shall have provision for accepting a manually commanded position update initiated while directly over a checkpoint when in the Inertial Only Mode.

3.6.1.3.3 Calibration. The system shall have provision for measuring the residual (uncompensated) INS gyro biases. This shall be a test mode used only with the aircraft stationary (i.e., brakes locked).

3.6.1.3.4 Attitude Backup. The system shall provide backup attitude reference mode in which platform verticality can be maintained at a reduced accuracy with no torquing compensation. The X and Y accelerometers in the INS shall provide level references for the X and Y gyro axes. In the attitude mode, the operation of the INS shall be autonomous with no inputs required from other sensors.

3.6.1.4 GPS Only Mode. A selectable navigation mode shall be provided in the system where position and velocity outputs shall be obtained solely from the GPS receiver measurements. No inertial velocity aiding signals shall be supplied to the GPS receiver.

3.6.1.4.1 GPS Only Performance. The navigation performance is specified based on the conditions assumed in 3.6.1.1.1. Under these conditions, the velocities of Table 6 and  $J/S \leq \text{---}$ , the GPS only steady state performance shall be:

Horizontal Position Error = TBD

Vertical Position Error = TBD

Velocity Error = TBD

3.6.1.4.2 GPS Receiver Characteristics.

3.6.1.4.2.1 Receiver Functional Characteristics. The GPS receiver set shall receive and process radio frequency (rf) signals at the L<sub>1</sub> and L<sub>2</sub> GPS frequencies with characteristics as specified in SS-GPS-300A. The receiver shall output measurements of pseudo range, pseudo range rate, differential L<sub>1</sub>/L<sub>2</sub> delay, and navigation data extracted from the navigation signals. The receiver shall also output the time at which the pseudo range and pseudo range rate measurements are valid. At least four independent tracking channels shall be provided such that four pseudo range and four pseudo range rate measurements can be made simultaneously. The receiver shall also accept data to aid in the acquisition and tracking of the navigation signals.

3.6.1.4.2.2 GPS Receiver Modes of Operation.

3.6.1.4.2.2.1 Acquisition Modes. The GPS receiver set shall be able to acquire signals in both the normal and direct modes of acquisition. The normal acquisition mode is defined as the acquisition of any C/A signal as an aid in the acquisition of its associated P-signal. The direct acquisition mode is defined as the acquisition of the P-signal without the aid of its associated C/A signal.

3.6.1.4.2.2.2 Track Mode. Following the acquisition of signals from four satellites, the GPS receiver shall track the P-code (or C/A code) and the carrier frequency of the four satellite signals in order to provide pseudo range rate measurements. For each pseudo range measurement the relation

$$\text{Pseudo range} = \text{user time} - \text{channel time}$$

shall be true where,

$$\text{User time} = \text{the receiver clock time}$$

$$\text{Channel time} = \text{the time from which the channel P-code is derived at the time of measurement}$$

3.6.1.4.2.2.3 Signal Hold-on Mode. The GPS receiver shall provide a hold-on mode in which code lock is maintained but at a degraded accuracy in order to provide rapid recovery to the precision tracking condition without having to enter an acquisition/reacquisition mode.

3.6.1.4.2.3 GPS Receiver Performance.

3.6.1.4.2.3.1 Signal Levels. The GPS receiver shall be able to acquire and track GPS navigation signals with the following signal levels:

<u>Frequency</u>	<u>P</u>	<u>C/A</u>
L <sub>1</sub>	-163 to -150 dBw	-163 to -150 dBw
L <sub>2</sub>	-166 to -150 dBw	-166 dBw

3.6.1.4.2.3.2 Equipment Stabilization Period (ESP). ESP is the time from equipment turn-on until the 1 sigma pseudo range and pseudo range rate measurement accuracies specified in Table 2 are achieved using the normal acquisition mode. The GPS receiver shall not exceed the ESP times specified below for the J/S condition given and over the temperature range of -20°C to +55°C.

TABLE 2 ESP and J/S Conditions

J/S (dB)	ESP (minutes)
+19	TED
+25	TED
—	—
—	—
—	—

3.6.1.4.2.3.3 Time-to-first-fix (TTFF). TTFF is defined as the amount of time required to produce a single point navigation solution from the start of the acquisition mode. The GPS receiver shall achieve the TTFF's under simultaneous conditions listed in Table 3. The 3 sigma range measurement errors, including ionospheric and tropospheric modeling/measurement errors, as well as multipath errors, used to compute the first single point navigation solution shall not exceed \_\_\_ meters.

3.6.1.4.2.3.4 Signal Loss Performance. After the signal tracking process has begun, the GPS receiver shall continue tracking the navigation signals with a probability of unintentional signal loss of less than \_\_\_ under the signal conditions of 3.6.1.4.2.3.1, the dynamic conditions of 3.6.1.4.2.3.9, and the J/S conditions of 3.6.1.4.2.3.7. Signal loss performance does not apply to routine terminations of signal tracking, which are inherent to the receiver functional process (e.g., selecting new signals, sequential tracking routines, etc.) or loss due to masking.

TABLE 3 TTFF and Simultaneous Conditions

Acquisition Mode	Normal		Direct (Internal Clock)	
	Poor	Good	Poor	Good
J/S Conditions				
TTFF (sec)	TBD	TBD	TBD	TBD
Probability of Success (%)	TBD	TBD	TBD	TBD
**Position Uncertainty (Km) (1 sigma)	TBD	TBD	TBD	TBD
***Velocity Uncertainty (m/sec) (1 sigma)	TBD	TBD	TBD	TBD
Max. Vehicle Acceleration (m/sec <sup>2</sup> )	TBD	TBD	TBD	TBD
Max. Vehicle Jerk (m/sec <sup>3</sup> )	TBD	TBD	TBD	TBD

\*Receiver Input Signal Level  $\leq$  \_\_\_ dBw but not to exceed \_\_\_ dBw. For a uniform distribution of position and velocity uncertainty, the specified J/S increases by \_\_\_ dB.

\*\*For a Gaussian distribution.

\*\*\*User clock uncertainty of \_\_\_ sec, 1 sigma.

3.6.1.4.2.3.5 Signal Hold On Performance. In the hold-on mode, the GPS receiver shall be capable of continuing to track the PN code for J/S conditions of at least \_\_\_ and \_\_\_ dB for the C/A and P signals, respectively.

3.6.1.4.2.3.6 Signal Reacquisition. The GPS receiver shall reacquire the navigation signals subsequent to loss within the time limits and under the conditions specified in Table 4.

TABLE 4 Reacquisition

SIGNAL	P	C/A
Loss Period (sec)	TBD	TBD
Reacquisition time (sec)	TBD	TBD
Probability of reacquisition	TBD	TBD
Position uncertainty* (M) (1 sigma)	TBD	TBD
Velocity uncertainty* (M/sec) (1 sigma)	TBD	TBD
Acceleration uncertainty* (M/sec <sup>2</sup> ) (1 sigma)	TBD	TBD
Jerk uncertainties* (M/sec <sup>3</sup> ) (1 sigma)	TBD	TBD
J/S condition (dB)**	TBD	TBD

\*For a Gaussian distribution.

\*\*Receiver Input Signal Level  $\geq$  \_\_dBw but not to exceed \_\_ dBw.

3.6.1.4.2.3.7 Jamming Immunity. The GPS receiver shall perform the functions listed in Table 5 under the jamming signal-to-navigation signal received power ratio (J/S) conditions specified in Table 5, the conditions specified in paragraphs 3.6.1.4.2.3.1. and the velocity conditions in paragraph 3.6.1.4.2.3.9.

TABLE 5 J/S Margins\*\*

Signal	*** Initial Signal Acquisi- tion	Carrier			Data Recovery Bits		Ionosphere
		Lock	Track	*Code Track	By the Reception (P = .99)	Error Rate (10 <sup>-5</sup> )	
P (J/S-dB)	TBD	TBD	TBD	TBD	TBD	TBD	TBD
C/A (J/S-dB)	TBD	TBD	TBD	TBD	TBD	TBD	TBD

\*When the INS is used, code tracking and sync recovery shall be maintained for J/S conditions of at least \_\_ dB for the P-signal and \_\_ dB for the C/A signal.

\*\*Receiver Input Signal Level  $\geq$  \_\_dBw but not to exceed \_\_ dBw.

\*\*\*For a uniform distribution of position and velocity uncertainty, the specified J/S increases by \_\_dB for the P-signal and \_\_ dBw for the C/A signal.

3.6.1.4.2.3.8 Data Recovery Performance. The GPS receiver set shall recover the data from the navigation signals with a Bit Error Rate (BER) of not greater than \_\_, and a probability of correct reception of a data byte of \_\_ under the conditions given in paragraphs 3.6.1.4.2.3.1, 3.6.1.4.2.3.7, and 3.6.1.4.2.3.9.

3.6.1.4.2.3.9 User Vehicle Dynamics. The GPS receiver set shall meet the performance requirements given in paragraphs 3.6.1.4.2.3.1, 3.6.1.4.2.3.7, 3.6.1.4.2.3.8 and 3.6.1.4.2.3.10 under the vehicle dynamics specified in Table 6.

TABLE 6 User Vehicle Dynamics

Dynamic Condition	Range of Dynamics
Velocity (M/sec)	TBD
Acceleration (M/sec <sup>2</sup> )	TBD
Jerk (M/sec <sup>3</sup> )	TBD

3.6.1.4.2.3.10 Measurement Errors.

Ranging error - The GPS receiver shall not exhibit any steady state ranging error due to constant acceleration. Total 3 sigma range measurement errors including dual frequency ionosphere, troposphere correction and multipath errors shall not exceed \_\_\_ meters under the conditions specified in paragraphs 3.6.1.4.2.3.1, 3.6.1.4.2.3.7 and 3.6.1.4.2.3.9. The error in range measurement due to biases between receiver channels, receiver channel delay variation shall not exceed \_\_\_ meters.

Range rate error - Range rate is a measure of the change in range over a defined interval, T, in which the interval T immediately precedes the demand for the measurement. The total 1 sigma range measurement errors shall not exceed \_\_\_ meters of  $T \geq$  \_\_\_ seconds under the conditions specified in paragraphs 3.6.1.4.2.3.1, 3.6.1.4.2.3.7 and 3.6.1.4.2.3.9.

Signal propagation delay error - Using direct rf measurements, the GPS receiver system shall measure ionospheric signal delay to 1 sigma accuracy not exceeding \_\_\_ meters under the conditions of paragraphs 3.6.1.4.2.3.1 and 3.6.1.4.2.3.9. The GPS receiver system shall be able to compensate for ionospheric propagation signal delay by use of modeling techniques.

Pseudo range and pseudo range rate measurement accuracy - The GPS receiver set shall measure pseudo range rate to an accuracy that meets or exceeds that specified in Table 7 under the conditions specified in paragraphs 3.6.1.4.2.3.1 and 3.6.1.4.2.3.7 and over the range of velocities specified in Table 6.

TABLE 7 Pseudo Range and Pseudo Range rate Measurement Accuracy

Error (1 Level)	P Signal	C/A Signal
Range (meters)	TBD	TBD
*Range Rate (meters)	TBD	TBD

\*Integration Time  $\geq$  \_\_\_ sec.

3.6.1.5 Dead Reckoning Mode Using True Airspeed and Heading. The System shall compute North and east velocity from sensor inputs of magnetic heading and true airspeed. Stored or computed variation shall be utilized along with earth's radius computations to supply geodetic position.

3.6.2 Weapon Delivery. The Weapon Delivery Function of the System shall interface with all other functions to provide the capability and performance described herein. The following modes of air-to-ground weapon delivery shall be provided: Blind, Dive Toss and Continuously Computed Impact Point. The aircraft shall not be restricted to fly a predetermined altitude or airspeed, nor shall he be required to maintain vertical velocity at zero, except for the low altitude bombing (LABS) mode. For all modes, the weapon delivery solution shall compensate for ejection velocity and rack delay. Multiple releases shall be generated to give weapon spacing on the ground, accounting for speed and flight profile. The system ballistic equations shall cover all air-to-ground weapon release envelopes. The system shall be capable of blind weapons delivery in GPS weapon delivery modes. Blind weapon delivery in the Inertial (only) mode will be degraded and that degradation is dependent on the length of time since a GPS update has occurred. The navigation function shall provide navigation mode, three-dimensional aircraft position, velocity, and attitude, and wind information to the Weapon Delivery Function.

Through the Steering Function, steering signals shall be presented on the attitude director indicator (ADI), horizontal situation indicator (HSI), and the HUD. The steering signals shall also be available to the Automatic Flight Control System, (AFCS).

The following input parameters shall be provided by the Control/Display Function to the Weapon Delivery Function:

Weapon Identifier  
 Ejection Velocity  
 Release Advance  
 Multiple Drop Spacing  
 Quantity  
 Target Elevation  
 Blind Identification Point to target distance  
 LABS Timer-Start Range  
 Break Altitude  
 Cross-Track Error Limit

Through the Sensor Cueing Function, the system shall provide a coordinated cue and slew control to the HUD, the radar antenna, the radar cursors. This capability of the system shall be used to identify and update targets in the blind weapon delivery modes, and provide ranging in the visual modes. In the case of air-to-ground missiles, the system will aid in acquiring a target prior to missile lock-on.

### 3.6.2.1 Weapon Delivery Modes.

3.6.2.1.1 Blind Bombing. There shall be several submodes within the Blind Bombing mode. The major divisions are GPS and Sensor.

(a) GPS. In the GPS Blind submode, the system shall provide steering information to a target selected as a destination on the System displays in the normal manner. The HUD reticle, the radar antenna (if in the air-to-ground mode) shall be cued to the destination coordinates. A pictorial representation typical of this mode is shown in Figure 6.

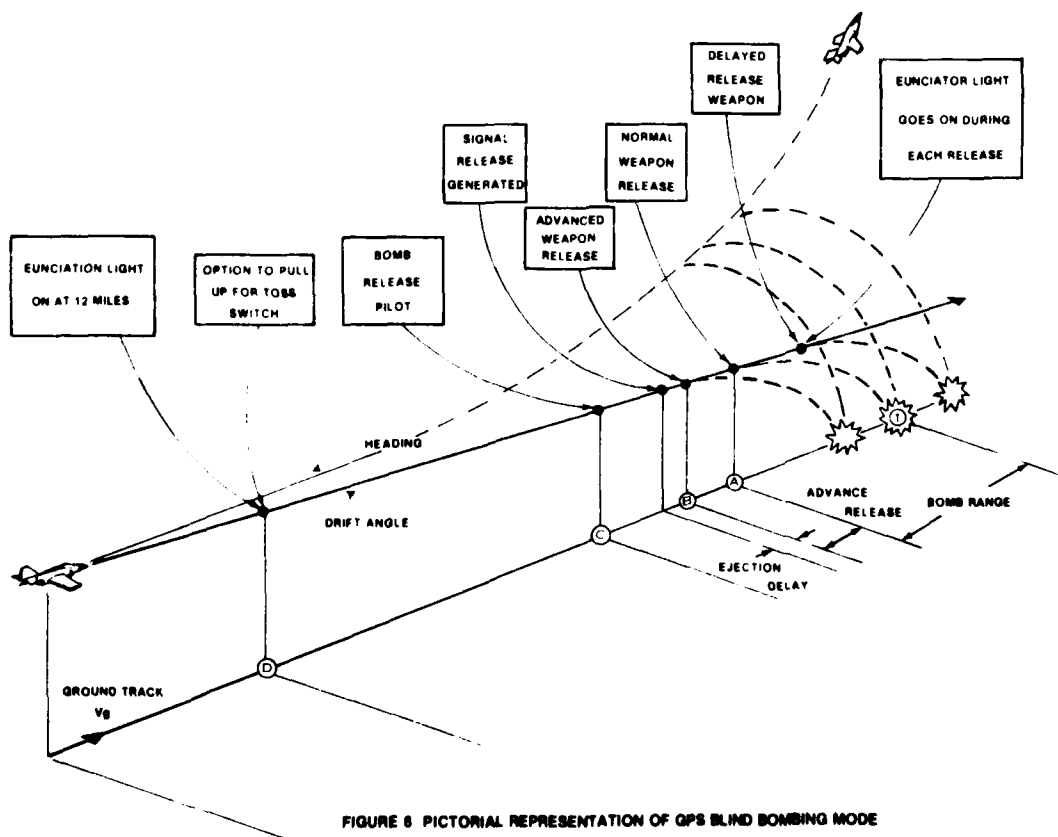

FIGURE 6 PICTORIAL REPRESENTATION OF GPS BLIND BOMBING MODE

Roll steering (or AFCS steering) will continually provide indications to the release point. Cross-wind correction for the anticipated release point is continuously updated except during the period immediately prior to illuminating the In-Range Indicator. During this period, the cross-wind correction for the predicted release point assumes that a pull-up will occur immediately following the In-Range Indication. This is the maximum cross-wind correction and, if pull-up is initiated, the lateral corrections required are minimized.

After the In-Range Indicator is illuminated, the predicted release point cross-wind correction is based on the existing aircraft dynamics. Thus, until a pull-up is initiated, the cross-wind correction constantly diminishes and most roll corrections are accomplished during one "g" flight. The corrections are continuous and maintained for all vertical maneuvers.

Also, the Horizontal Pointer of the ADI will indicate (after In-Range Indication) a dive angle which will result in weapon release in the dive at approximately the break altitude. This indication is a cue to the pilot; control of the vertical path shall be maintained as an operator's option.

(b) Sensor. In the Sensor Blind Bombing submode, the system shall provide steering commands via the ADI, HSI, and HUD to a stored destination. The HUD aiming reticle and the radar cursors will all be cued to point at this destination if they are in the system mode and have not been trimmed by the hand control. The operator(s) may select any one of the available operating sensors to identify and update the target position.

3.6.2.1.2 Dive Toss. The System Dive Toss mode shall provide all the capabilities and functions for the Dive Toss described herein. Elevation and azimuth signals to point the HUD reticle along the earth-referenced elevation angles of the aircraft velocity vector and, in azimuth, to the predicted cross-track impact distance shall be provided. The System shall compute the HUD commands based on weapon delivery equations and aircraft attitude to provide a stabilized aiming reticle. When the aircraft is maneuvered such that the HUD aiming reticle is on the target and the bomb release switch is depressed, the System computer shall determine the relative position between aircraft and target. This computation will normally use radar slant range. However, if either the radar range or laser range tracking loops are not locked on or if the grazing angle is less than a value that gives acceptable range signals, the direction cosines of the aiming vector shall be scaled with altitude above target. This shall be computed by the System from the difference between baro-inertial altitude and the inserted target elevation.

a. Having established (designated) the relative position between the target and aircraft, the System shall then use GPS-inertial velocity and baro-inertial altitude rate to compute relative position and to provide roll steering until release occurs. A lateral steering command shall be presented on the HUD's roll reticle (and the vertical pointer of the ADI) between target designation and weapon release. This steering command shall be roll error which compensates for variation in wind (cross trail) based on predicted time-of-fall and measured wind. The predicted impact point shall pass through the target. Automatic release shall occur when the predicted along-track range (including wind compensation) plus release advance equals the along-track range to target. In order for auto release to occur, the bomb release switch must be maintained in the depressed position.

b. The System shall not require preprogrammed vertical path maneuvering. An "In Range" cue will indicate when a pull-up may be started for a maximum standoff range release following this indication. The aircraft is not required to fly any fixed altitude, airspeed, or dive angle. Figure 7 shows a typical pictorial representation of this mode.

3.6.2.1.3 CCIP. The System Continuously Computed Impact Point (CCIP) mode shall provide the capability to accurately deliver weapons on visual targets from level flight to steep dive angles. When the predicted impact point for an immediate release is within the field of view (FOV), the timing reticle of the HUD shall be driven by signals from the system to point at the impact point as if the weapon were released immediately. The system shall also provide command signals to the radar antenna and to electro-optic system so that both systems point to the weapon impact point.

a. When the predicted immediate release impact point is out of the FOV, the aiming reticle shall be driven near the HUD field of view limit in the vertical axis. In the lateral axis, the aiming reticle shall be driven such that wings level flight is predicted to pass the impact point through the point under the aiming reticle.

b. Weapon release will be delayed until the predicted impact point coincides with the designated target. Steering signals for weapon delivery shall be terminated at time of last weapon release.

c. The CCIP mode, whether immediate or delayed release, shall permit the aircraft commander to designate the target as near the release point as possible. In the primary mode, target coordinates shall be determined by the System from aircraft attitude, radar slant range or laser range. In the secondary mode (automatically selected by the System) the difference between aircraft altitude and target elevation shall be used instead of measured slant range.

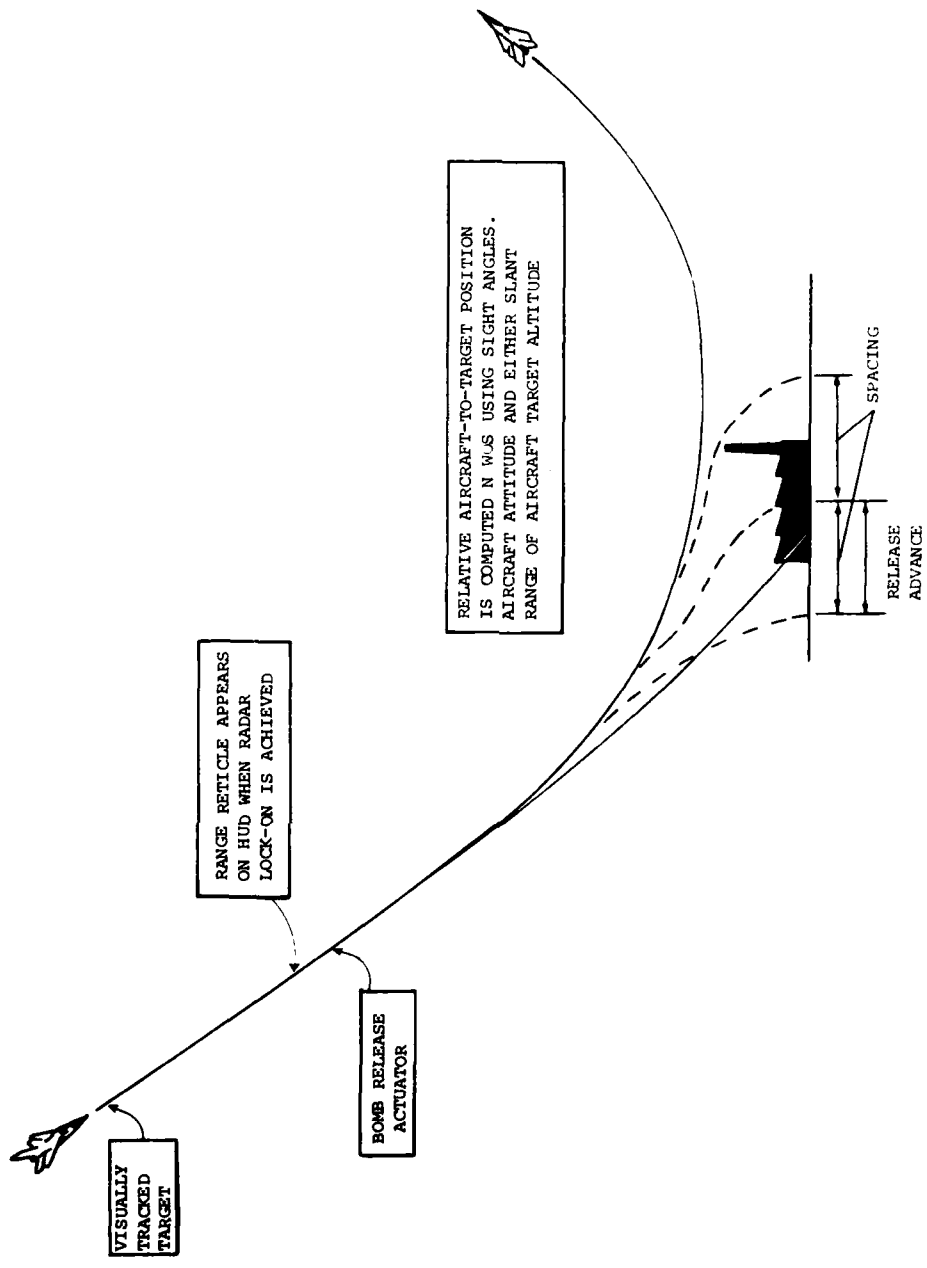

FIGURE 7 - PICTORIAL REPRESENTATION OF THE DIVE TOSS MODE

3.6.2.1.4 Guns. TBD

3.6.3 Steering. The System shall compute steering information relative to operator-inserted destinations based upon fixed course or direct track, as determined by the operator. Steering information shall be displayed on the aircraft flight instruments.

3.6.3.1.1 Steering Destination. Both Fixed Course and Homing (direct track) modes of steering shall be available. In the Fixed Course mode, steering information shall be supplied via the HSI and ADI for an optimum intercept (tangential) to a given radial course from the selected destination. In the Homing mode, the steering information shall establish an optimum track for the most direct course to the selected destination.

3.6.3.1.2 Automatic Destination Sequencing. Automatic sequencing of steering commands to a programmed set of destinations shall be provided. A smooth transition shall be made between each leg of the course. Steering commands shall provide the over flight of all destinations.

3.6.3.1.3 Approach To Land. When the Approach mode is selected, the System shall provide steering to the touch down point along a course which has been previously entered as runway heading. Altitude error, cross track error, and lateral steering will be displayed on the horizontal pointer of ADI only when the aircraft is within \_\_\_ nautical miles downwind of the touch down point, the cross track error is less than \_\_\_ feet plus a percentage of the Along-Track Distance (ATD), and the ground track angle is within \_\_\_ degrees (plus a function of the ATD) of the runway heading.

3.6.3.1.4 AFCS Steering. The System shall supply lateral command signals to the Automatic Flight Control System (AFCS) both for navigation modes and the Weapon Delivery modes. These command signals shall be generated by implementing the identical control equations and logic which are used for the steering commands presented on the ADI and the HUD to steering mode, the AFCS shall be overridden by the application of lateral stick-force. However, with the release of this force, the automatic steering shall again take over. The automatic mode may be disengaging the AFCS.

Automatic steering of the pitch axis shall be provided in the Approach mode only. The error in glide path from the System shall replace the altitude error coming from the CADC in the Altitude Hold mode. Automatic steering of pitch axis shall be smoothed and dampened so as not to intensify atmospheric conditions.

3.6.3.2 Steering Mechanization. The lateral steering signals to the vertical pointer of the ADI, and the roll axis of the AFCS shall be proportional to roll attitude error; i.e., the difference between desired and actual roll attitude. The signals shall be proportional to (and the sign dependent on) the difference between existing roll attitude and the roll attitude required (as computed in the System). The director signal shall be zero whenever the aircraft roll angle is the same as that required to perform the maneuver. The System shall use cross track error, selected course angle or bearing to destination, ground track angle, roll attitude and ground velocity to compute the bank angle desired. Steering signals shall be provided during all modes if the operator desires. Steering shall also be provided during weapon release modes; however, for Dive/Toss and CCIP modes, the steering shall not be activated until the target has been designated. The operator shall have the option to steer laterally from the ADI, the HUD or automatically via the AFCS.

3.6.4 Sensor Cueing. The System Sensor Cueing Function shall provide the capability to perform individual and coordinated sensor cueing using the best available sensor and navigation information in order to provide to the operator and to the Weapon Delivery Function the best available information of target position relative to aircraft position.

The Sensor Cueing Function shall provide the capability to perform individual and coordinated sensor cueing using the best available sensor and navigation information in order to provide to the operator and to the Weapon Delivery Function the best available information of target position relative to aircraft position.

The Sensor Cueing Function shall accept pointing angle and slant range data as a minimum from the following aircraft sensors:

- a) Radar
- b) Electro-Optical System(s)

The above sensors shall be individually selectable or cued in a coordinated manner to operator-selected ground position coordinates or to a target of opportunity to either identify and/or to update the target position. The initial target coordinates may have been inserted by the operator or identified using the outputs from one of the sensors. The target point may be a destination target, a

weapon delivery target or a destination that is offset from a weapon delivery target. When a weapon delivery target is defined by an offset from a sensor target, the steering function shall automatically provide steering to the offset weapon delivery target coordinates. The operator shall have the freedom of cueing the sensors to either target while the steering function provides continuous steering to the weapon delivery target.

The manner in which information from each sensor is utilized in the various weapon delivery modes is described in section 3.6.2. The functional characteristics required for cueing of each sensor are described herein.

3.6.4.1 HUD. The System Sensor Cueing Function shall provide azimuth and elevation signals to point the HUD reticle in order to provide either (a) cueing to a target location defined by ground coordinates, or (b) aiming for estimated weapon ground impact-point display for pilot-identified targets of opportunity. The System shall utilize the best available estimate of slant range to the target (obtained from electro-optical systems, radar, or derived from difference between baro-inertial altitude and inserted target altitude) in order to determine the pointing angles for the HUD. When visual target sighting can be made, the HUD aiming reticle shall be capable of trimming to the target. The capability to compute target coordinates for ground points designated via the HUD shall be provided. Weapon impact point line-of-sight computations shall also be used to provide coordinated pointing of other sensors for viewing and evaluation of targets of opportunity.

3.6.4.2 Radar. The Sensor Cueing Function shall interface with the Radar in both the radar ground mapping and ranging modes. The mapping mode shall be used for target line-of-sight (LOS) identification based radar return. The ranging mode shall be used for radar slant range determination of the ground point along the same LOS. A coordinated cue capability shall be provided such that the radar antenna can be pointed to a LOS direction common to the other sensors. The system shall provide radar cursor control for target location.

3.6.4.3 Electro-optical System(s). The Cueing Function shall interface with the electro-optic system(s) to obtain slant range and direction cosines for an operator selected target. The target may be a destination point selected at the start of mission or a target of opportunity. The System shall provide necessary initial cueing information to the electro-optic system.

### 3.6.5 Control and Display.

3.6.5.1 Display Requirements. The System shall supply flight parameters on the system Digital Display Indicator as shown in Table 8 and parameters on aircraft instruments as shown in Table 9.

3.6.5.2 Control Requirements. The System as a minimum shall provide the following controls:

- (1) Steer controls to select the mode of navigation steering.
  - (a) NAV-M, the manual navigation mode, provides steering to a single destination as selected via keyboard.
  - (b) DISENG to disengage all system steering outputs.
  - (c) NAV-A, the automatic navigation mode which provides steering to sequential destinations.
  - (d) FRX OFS LINK WPN which allows selection of a priority steer destination.

TABLE 8 Digital Display Indicator

INFORMATION SELECTED FOR DISPLAY	FRAME OF REFERENCE
Present Position	Latitude-Longitude
Present Position	UTM
Destination Location	Latitude-Longitude
Range to Destination	Rhumb Line Distance
Magnetic Bearing to Destination	Rhumb Line Bearing
Track/Cross-Track	Selected Course
Estimated Time Enroute	Hours, Minutes
Magnetic Variation	Degree
Ground Speed	Knots
Ground Track	Degrees

TABLE 9 System Flight Instrument Outputs, Resolutions, and Characteristics

FUNCTION	TYPE LOAD	ELECTRICAL CHARACTERISTICS
Bearing	Synchro	TBD
Distance	Synchro	TBD
Course Deviation	Microammeter	TBD
Displacement Deviation	Microammeter	TBD
Course & Displacement Flag Alarm	Microammeter	TBD
Distance Flag	Solenoid	TBD
To-From Indicator	Microammeter	TBD

(2) Data controls to select, monitor, insert, and change navigational parameters in the following major classes:

- (a) DEST - for destinations and their associated parameters which define these locations.
- (b) MISSION - for data unique to the particular mission of the aircraft.

- (c) GPS - for data associated with the GPS stations used for navigation.
  - (d) UPDATE - for parameters used in initialization of the system and in updating them such as present position, altitude, magnetic variation, and time.
  - (e) CUE - for position data used for target designator cueing of narrow field of view sensor.
  - (f) FLT - to allow selection of desired flight parameters for immediate display on the Digital Display Indicator.
  - (g) CAL/TEST - to allow automatic calibration of radar, etc., and automatic test of the controls and displays.
- (3) parameter controls to select the desired navigational coordinate system for position readout and entry:
- (a) LL - Latitude/longitude
  - (b) UTM - Universal Transverse Mercator
- (4) Pushbutton controls for program control and miscellaneous functions such as the following:
- (a) INSERT - to insert the displayed data into the system memory. This is the only guarded key.
  - (b) SKIP - to advance the interactive program one step.
  - (c) BULK ERASE - to erase all data within a designated class when used in conjunction with INSERT.
  - (d) CLEAR - to clear the appropriate display row and direct the keyboard alphanumeric entry to the cleared row.
  - (e) DATA EXIT - to allow immediate exit from within a data list and to place the program back at the initial step.
  - (f) DECREMENT - to allow for backing up the interactive program one step for each time the decrement key (alphanumeric "D" key) is pushed; or until the first parameter of a data list is reached.
  - (g) FRZ - to freeze a data set and display it on the Digital Display.
  - (h) OFS - to indicate by illuminating that an offset targetting solution is available for display and/or storage. When the key is latched, the data shall be displayed on the Digital Display.
- (5) Miscellaneous controls:
- (a) Lamp Test - Selecting the LAMP mode shall initiate a lamp test illuminating all annunciator lamps, decimal points, colon, and numeric readout segments.
  - (b) System power control.
  - (c) Navigation mode selection (GPSINT, GPSINS, GPS, INS, or DR).
  - (d) INS Selector - INS selector shall provide a system ON/OFF and four INS modes.
- (1) Align

(2) Navigation

(3) Calibrate

(4) Attitude

3.6.6 Built-in-test (BIT). The System shall contain built-in-test provisions within each box to isolate failures to the LRU. The resultant fault signals shall be sent to the computer for the determination of system readiness. An in-line BIT function shall provide continuous monitoring of system operational status during flight. A more detailed software routine shall be employed for ground BIT.

3.6.6.1 Airborne BIT. An airborne test software program shall compute periodically at an iteration rate sufficient to assist in the determination of system readiness. Tests shall be performed by the software on the basic computer functional capabilities--ability to add, subtract, multiply, divide, perform branch operations, transfer data, shift and perform other elementary operations on a fixed data set. These functions shall be continuously verified within the arithmetic unit. Results -- "pass or fail" -- of individual tests shall be stored in a BIT status word for use in the debugging of the machine.

a. In addition to the tests of the arithmetic unit, the memory unit shall be tested to verify the capability to read and write data into the computer memory under computer control. System interface channels shall be continually checked to confirm the ability of the computer to communicate with peripheral devices.

b. The data conversion functions shall be checked for failure on a regular or iterative rate basis with in-line tests being performed on at least one input data channel to verify the operability of the converter unit. The presence of input reference voltages will be monitored under software control.

c. BIT status words shall be maintained within the computer memory to record the type of test failed. A detected failure in any unit shall cause a system Malfunction Warning Lamp (MALF) to illuminate. If the computer has failed, a COMP-MALF annunciator shall be illuminated.

3.6.6.2 Ground BIT. The System shall contain a special GO/NO-GO mode of operation separate from normal operational modes. Features of the airborne BIT tests shall be retained in this mode in addition to other canned conditions designated to test the interface and navigational capabilities of the System. A special test signal shall be generated and injected at the Antenna Coupler for testing data conversion and GPS Receiver operation. A canned position shall be assumed in addition to a course, destination, magnetic variation, altitude, glide slope, ground speed, and track angle. All normal flight navigation functions shall be computed by the program, and output values shall be selected to provide easy and correct verification of system readiness.

a. A sequential display routine shall also be provided for checking analog inputs and switch settings on the System keyboard and rotary function switch. A technique shall also be provided for testing of all warning lamps and display elements.

b. The ground BIT shall be initiated by depressing a BIT button and keyboard "INSERT" key. The display unit shall identify the failed LRU. This test shall be locked when the aircraft is airborne.

#### 4.0 QUALITY ASSURANCE PROVISIONS

4.1 Responsibility for Inspection. Unless otherwise specified in the contract, the supplier is responsible for the performance of all inspection requirements as specified herein. Except as otherwise specified, the supplier may utilize his own facilities or any commercial laboratory acceptable to the Government. The Government reserves the right to perform any of the inspections set forth in specifications where such inspections are deemed necessary to assure supplies and services conform to prescribed requirements.

4.2 Quality Assurance. The provisions of MIL-E-5400 and the requirements specified herein shall be applicable to this specification. When the two documents conflict, this specification shall govern.

4.3 Classification of Tests. The inspection and testing of the System shall consist of the following groups of tests:

- (a) Performance tests
- (b) Simulator tests
- (c) Flight tests

4.4 Test Conditions. Unless otherwise specified, the System shall be subjected to all tests under the following conditions:

- (a) Temperature - Room ambient
- (b) Altitude - Normal ground
- (c) Vibration - None
- (d) Humidity - Room ambient

4.5 Performance Tests. A pre-production System shall be subjected to tests to demonstrate system performance. Performance tests shall be preceded by an Acceptance Test Procedure.

4.6 Simulator Tests. TBD

4.7 Flight Tests. TBD

#### 5.0 PREPARATION FOR DELIVERY

The System shall be prepared for delivery in accordance with MIL-STD-794.

#### 6.0 NOTES

APPENDIX B

The attached material includes a description of a Kalman filter implementation which could serve as a point of departure in formulating an Integrated NAVSTAR/GPS Digital Avionics System processing algorithm. This implementation is based upon the Upper Triangle - Diagonal (U-D) formulation. This algorithm can be modified to add the additional sophistication which is necessary to satisfy the proposed systems operational requirements.

An implementation of the Upper Triangle - Diagonal formulation is summarized in the following equations:

Assume an N state filter and M scalar observations each modeled by:

$$z_i = H_i^T \cdot X + v_i \quad i = 1, \dots, M$$

where

- $z_i$  =  $i^{\text{th}}$  scalar observation
- $v_i$  = observation error for  $i^{\text{th}}$  observation having variance  $r_i$
- $X$  = N element a priori state vector estimate having a priori error covariances  $P$
- $H_i$  = N element transformation vector for  $i^{\text{th}}$  observation

The Kalman filter a priori covariance matrix  $P$  (N rows by N columns) can be factored into a diagonal matrix  $D$  and an upper triangular, unit diagonal matrix  $U$  such that

$$P = U D U^T$$

a. The minimum variance a posteriori state vector estimate ( $\bar{X}$ ) and its error covariance factors ( $U, D$ ) are computed from the a priori variables  $X, U$  and  $D$  after the  $i^{\text{th}}$  observation. First, a vector  $V_i$  is computed:

$$V_i = D U^T H_i$$

Then an algorithm is used to simultaneously compute  $U, D$ , the Kalman filter gains ( $K_i$ ) and the observation covariance  $a_i$  that satisfy the following equations:

$$a_i = H_i^T U D U^T H_i + r_i$$

$$K_i = U V_i / a_i$$

$$W = D - (1/a_i) V_i V_i^T$$

$$U D U^T = W \quad (\text{i.e., factor } W)$$

$$U = U U$$

Finally, the a posterior state vector estimate is computed.

$$z_i = z_i = H_i^T X$$

$$X = X + K_i z_i$$

b. Time updating of the covariance factors is accomplished by the following method:

$$W = \Phi W$$

$$W = W D$$

$$P = W W^T + Q$$

where

- $\Phi$  = state transition matrix
- $Q$  = process noise covariance matrix

This result is then factored via the method of Gauss\* into  $U$  and  $D$  components.

c. Sample editing to eliminate incorporation of contaminated information is performed when

$$z_i/a_i^2 \quad \text{test value}$$

When a sufficient occurrence rate of bad samples is detected, jamming is assumed to be present. During extended periods of jamming, the value of  $a_i$  used is limited to prevent eventual acceptance of jammers.

\*Gantmacher, F.R. The Theory of Matrices.

LIST OF REFERENCES

1. Noe, P.S. and Myers, K.A., "A Position-Fixing Algorithm for the Low-Cost GPS Receiver," IEEE Trans. on Aerospace and Electronics Systems, AES-12, No. 2, March 1976.
2. Bierman, G.J., "A Square Root Free Triangular Factorization of the Kalman Updating Formula," 1975 Conference of Decision and Control, Houston, Texas, December 1975.
3. Carlson, N.A., "Fast Triangular Formulation of the Square Root Filter," AIAAJ., Vol. 11, No. 9, 1973, pp. 1259-1264.
4. Gantmacher, F.R., "The Theory of Matrices," Chelsea Publishing Company, New York, New York, 1959, Vol. I, pp. 33-41.
5. Perfitt, T.E. and Pickel, F.E., "Tactical and Long-Range Navigation In the AN/ARN-101(V)," IEEE Plans, 1976.

**REPORT DOCUMENTATION PAGE**

1. Recipient's Reference	2. Originator's Reference AGARD-AR-147 Volume IIA	3. Further Reference ISBN 92-835-1349-5	4. Security Classification of Document UNCLASSIFIED
5. Originator	Advisory Group for Aerospace Research and Development North Atlantic Treaty Organization 7 rue Ancelle, 92200 Neuilly sur Seine, France		
6. Title	Report from the Guidance and Control Panel Working Group 04 on THE IMPACT OF GLOBAL POSITIONING SYSTEM ON GUIDANCE AND CONTROLS SYSTEMS DESIGN OF MILITARY AIRCRAFT SPECIFIC STUDY No.1: Application of the NAVSTAR/GLOBAL POSITIONING SYSTEM TO THE CLOSE AIR SUPPORT MISSION		
7. Presented at			
8. Author(s)/Editor(s) Editor: Mr Louis J. Urban	9. Date February 1980		
10. Author's/Editor's Address ASD/AX Wright-Patterson AFB Ohio 45433, USA	11. Pages 72		
12. Distribution Statement	This document is distributed in accordance with AGARD policies and regulations, which are outlined on the Outside Back Covers of all AGARD publications.		
13. Keywords/Descriptors  F.4 E avionics description Integrated NAVSTAR/GPS digital avionics system Performance simulation Navigation Weapon delivery			
14. Abstract  The objectives of the Guidance and Control Panel Working Group 04 were to consider the integration of GPS in aircraft systems and make recommendations for implementation.  The Working Party report consists of two volumes:  <i>Volume I</i> includes NAVSTAR/GPS description, examination of technical aspects of the system, applications to Counter Air Operations, Air Interdiction, Close Air Support Operations, Sea Patrol and Strike RPV, and recommendations.  In <i>Volume II</i> are presented the results of four specific studies of the application of NAVSTAR to Close Air Support, Sea Patrol, Interdiction Strike and Strike RPV.  Volume IIA addresses the first of those specific studies. A currently available "model" was selected, namely the F.4E aircraft equipped with the ARN-101 weapon delivery system. This was selected since it represents the current state-of-the-art for externally aided (LORAN) digital avionics system integrated into a reasonably modern fighter aircraft which is currently in the operational inventory of several NATO countries. The study is unclassified and not NATO-CONFIDENTIAL as originally planned.  The report consists of one main document (Vol.I) and four appendices published separately (Volumes IIA, B, C and D).			

<p>AGARD Advisory Report No.147 Volume IIA Advisory Group for Aerospace Research and Development, NATO</p> <p>Report from the Guidance and Control Panel Working Group 04 on THE IMPACT OF GLOBAL POSITIONING SYSTEM TO GUIDANCE AND CONTROLS SYSTEMS DESIGN OF MILITARY AIRCRAFT SPECIFIC APPLICATION STUDY No.1: CLOSE AIR SUPPORT Edited by L.J.Urban Published February 1980 72 pages</p> <p>The objectives of the Guidance and Control Panel Working Group 04 were to consider the integration of GPS in aircraft systems and make recommendations for implementation.</p> <p>P.T.O.</p>	<p>AGARD-AR-147 Vol.IIA</p> <p>F.4E avionics description Integrated NAVSTAR/GPS digital avionics system Performance simulation Navigation Weapon delivery</p>	<p>AGARD-AR-147 Vol.IIA</p> <p>F.4E avionics description Integrated NAVSTAR/GPS digital avionics system Performance simulation Navigation Weapon delivery</p>	<p>AGARD Advisory Report No.147 Volume IIA Advisory Group for Aerospace Research and Development, NATO</p> <p>Report from the Guidance and Control Panel Working Group 04 on THE IMPACT OF GLOBAL POSITIONING SYSTEM TO GUIDANCE AND CONTROLS SYSTEMS DESIGN OF MILITARY AIRCRAFT SPECIFIC APPLICATION STUDY No.1: CLOSE AIR SUPPORT Edited by L.J.Urban Published February 1980 72 pages</p> <p>The objectives of the Guidance and Control Panel Working Group 04 were to consider the integration of GPS in aircraft systems and make recommendations for implementation.</p> <p>P.T.O.</p>
<p>AGARD Advisory Report No.147 Volume IIA Advisory Group for Aerospace Research and Development, NATO</p> <p>Report from the Guidance and Control Panel Working Group 04 on THE IMPACT OF GLOBAL POSITIONING SYSTEM TO GUIDANCE AND CONTROLS SYSTEMS DESIGN OF MILITARY AIRCRAFT SPECIFIC APPLICATION STUDY No.1: CLOSE AIR SUPPORT Edited by L.J.Urban Published February 1980 72 pages</p> <p>The objectives of the Guidance and Control Panel Working Group 04 were to consider the integration of GPS in aircraft systems and make recommendations for implementation.</p> <p>P.T.O.</p>	<p>AGARD-AR-147 Vol.IIA</p> <p>F.4E avionics description Integrated NAVSTAR/GPS digital avionics system Performance simulation Navigation Weapon delivery</p>	<p>AGARD-AR-147 Vol.IIA</p> <p>F.4E avionics description Integrated NAVSTAR/GPS digital avionics system Performance simulation Navigation Weapon delivery</p>	<p>AGARD Advisory Report No.147 Volume IIA Advisory Group for Aerospace Research and Development, NATO</p> <p>Report from the Guidance and Control Panel Working Group 04 on THE IMPACT OF GLOBAL POSITIONING SYSTEM TO GUIDANCE AND CONTROLS SYSTEMS DESIGN OF MILITARY AIRCRAFT SPECIFIC APPLICATION STUDY No.1: CLOSE AIR SUPPORT Edited by L.J.Urban Published February 1980 72 pages</p> <p>The objectives of the Guidance and Control Panel Working Group 04 were to consider the integration of GPS in aircraft systems and make recommendations for implementation.</p> <p>P.T.O.</p>

<p>The Working Party report consists of two volumes:</p> <p><i>Volume I</i> includes NAVSTAR/GPS description, examination of technical aspects of the system, applications to Counter Air Operations, Air Interdiction, Close Air Support Operations, Sea Patrol and Strike RPV, and recommendations.</p> <p>In <i>Volume II</i> are presented the results of four specific studies of the application of NAVSTAR to Close Air Support, Sea Patrol, Interdiction Strike and Strike RPV.</p> <p>Volume IIA addresses the first of those specific studies. A currently available "model" was selected, namely the F.4E aircraft equipped with the ARN-101 weapon delivery system. This was selected since it represents the current state-of-the-art for externally aided (LORAN) digital avionics system integrated into a reasonably modern fighter aircraft which is currently in the operational inventory of several NATO countries. The study is unclassified and not NATO-CONFIDENTIAL as originally planned.</p> <p>The report consists of one main document (Vol.I) and four appendices published separately (Volumes IIA, B, C and D).</p> <p>ISBN 92-835-1349-5</p>	<p>The Working Party report consists of two volumes:</p> <p><i>Volume I</i> includes NAVSTAR/GPS description, examination of technical aspects of the system, applications to Counter Air Operations, Air Interdiction, Close Air Support Operations, Sea Patrol and Strike RPV, and recommendations.</p> <p>In <i>Volume II</i> are presented the results of four specific studies of the application of NAVSTAR to Close Air Support, Sea Patrol, Interdiction Strike and Strike RPV.</p> <p>Volume IIA addresses the first of those specific studies. A currently available "model" was selected, namely the F.4E aircraft equipped with the ARN-101 weapon delivery system. This was selected since it represents the current state-of-the-art for externally aided (LORAN) digital avionics system integrated into a reasonably modern fighter aircraft which is currently in the operational inventory of several NATO countries. The study is unclassified and not NATO-CONFIDENTIAL as originally planned.</p> <p>The report consists of one main document (Vol.I) and four appendices published separately (Volumes IIA, B, C and D).</p> <p>ISBN 92-835-1349-5</p>
<p>The Working Party report consists of two volumes:</p> <p><i>Volume I</i> includes NAVSTAR/GPS description, examination of technical aspects of the system, applications to Counter Air Operations, Air Interdiction, Close Air Support Operations, Sea Patrol and Strike RPV, and recommendations.</p> <p>In <i>Volume II</i> are presented the results of four specific studies of the application of NAVSTAR to Close Air Support, Sea Patrol, Interdiction Strike and Strike RPV.</p> <p>Volume IIA addresses the first of those specific studies. A currently available "model" was selected, namely the F.4E aircraft equipped with the ARN-101 weapon delivery system. This was selected since it represents the current state-of-the-art for externally aided (LORAN) digital avionics system integrated into a reasonably modern fighter aircraft which is currently in the operational inventory of several NATO countries. The study is unclassified and not NATO-CONFIDENTIAL as originally planned.</p> <p>The report consists of one main document (Vol.I) and four appendices published separately (Volumes IIA, B, C and D).</p> <p>ISBN 92-835-1349-5</p>	<p>The Working Party report consists of two volumes:</p> <p><i>Volume I</i> includes NAVSTAR/GPS description, examination of technical aspects of the system, applications to Counter Air Operations, Air Interdiction, Close Air Support Operations, Sea Patrol and Strike RPV, and recommendations.</p> <p>In <i>Volume II</i> are presented the results of four specific studies of the application of NAVSTAR to Close Air Support, Sea Patrol, Interdiction Strike and Strike RPV.</p> <p>Volume IIA addresses the first of those specific studies. A currently available "model" was selected, namely the F.4E aircraft equipped with the ARN-101 weapon delivery system. This was selected since it represents the current state-of-the-art for externally aided (LORAN) digital avionics system integrated into a reasonably modern fighter aircraft which is currently in the operational inventory of several NATO countries. The study is unclassified and not NATO-CONFIDENTIAL as originally planned.</p> <p>The report consists of one main document (Vol.I) and four appendices published separately (Volumes IIA, B, C and D).</p> <p>ISBN 92-835-1349-5</p>

**AGARD**

NATO  OTAN

7 RUE ANCELLE · 92200 NEUILLY-SUR-SEINE  
FRANCE

Telephone 745.08.10 · Telex 610176

DISTRIBUTION OF UNCLASSIFIED  
AGARD PUBLICATIONS

AGARD does NOT hold stocks of AGARD publications at the above address for general distribution. Initial distribution of AGARD publications is made to AGARD Member Nations through the following National Distribution Centres. Further copies are sometimes available from these Centres, but if not may be purchased in Microfiche or Photocopy form from the Purchase Agencies listed below.

NATIONAL DISTRIBUTION CENTRES

**BELGIUM**

Coordonnateur AGARD - VSL  
Etat-Major de la Force Aérienne  
Quartier Reine Elisabeth  
Rue d'Evere, 1140 Bruxelles

**CANADA**

Defence Science Information Services  
Department of National Defence  
Ottawa, Ontario K1A 0K2

**DENMARK**

Danish Defence Research Board  
Østerbrogades Kaserne  
Copenhagen Ø

**FRANCE**

O.N.E.R.A. (Direction)  
29 Avenue de la Division Leclerc  
92320 Châtillon sous Bagneux

**GERMANY**

Zentralstelle für Luft- und Raumfahrt-  
dokumentation und -information  
c/o Fachinformationszentrum Energie,  
Physik, Mathematik GmbH  
Kernforschungszentrum  
7514 Eggenstein-Leopoldshafen 2

**GREECE**

Hellenic Air Force General Staff  
Research and Development Directorate  
Holargos, Athens

**ICELAND**

Director of Aviation  
c/o Flugrad  
Reykjavik

**ITALY**

Aeronautica Militare  
Ufficio del Delegato Nazionale all'AGARD  
3, Piazzale Adenauer  
Roma/EUR

**LUXEMBOURG**

See Belgium

**NETHERLANDS**

Netherlands Delegation to AGARD  
National Aerospace Laboratory, NLR  
P.O. Box 126  
2600 A.C. Delft

**NORWAY**

Norwegian Defence Research Establishment  
Main Library  
P.O. Box 25  
N-2007 Kjeller

**PORTUGAL**

Direcção do Serviço de Material  
da Força Aérea  
Rua da Escola Politécnica 42  
Lisboa  
Attn: AGARD National Delegate

**TURKEY**

Department of Research and Development (ARGE)  
Ministry of National Defence, Ankara

**UNITED KINGDOM**

Defence Research Information Centre  
Station Square House  
St. Mary Cray  
Orpington, Kent BR5 3RE

**UNITED STATES**

National Aeronautics and Space Administration (NASA)  
Langley Field, Virginia 23365  
Attn: Report Distribution and Storage Unit

THE UNITED STATES NATIONAL DISTRIBUTION CENTRE (NASA) DOES NOT HOLD STOCKS OF AGARD PUBLICATIONS, AND APPLICATIONS FOR COPIES SHOULD BE MADE DIRECT TO THE NATIONAL TECHNICAL INFORMATION SERVICE (NTIS) AT THE ADDRESS BELOW.

PURCHASE AGENCIES

*Microfiche or Photocopy*

National Technical  
Information Service (NTIS)  
5285 Port Royal Road  
Springfield  
Virginia 22161, USA

*Microfiche*

Space Documentation Service  
European Space Agency  
10, rue Mario Nikis  
75015 Paris, France

*Microfiche*

Technology Reports  
Centre (DTI)  
Station Square House  
St. Mary Cray  
Orpington, Kent BR5 3RF  
England

Requests for microfiche or photocopies of AGARD documents should include the AGARD serial number, title, author or editor, and publication date. Requests to NTIS should include the NASA accession report number. Full bibliographical references and abstracts of AGARD publications are given in the following journals:

**Scientific and Technical Aerospace Reports (STAR)**

published by NASA Scientific and Technical  
Information Facility  
Pentagon Bldg 5757  
Washington, Washington International Airport  
Maryland 20340, USA

**Government Reports Announcements (GRA)**

published by the National Technical  
Information Service, Springfield  
Virginia 22161, USA

Printed by Technical Information and Documentation Ltd  
Langley House, 7-9, Chancery St, London W1P 1ED

AGARD PUBLICATIONS 1989-5