

AD-A084 016

MAGNAVOX-GENERAL ATRONICS PHILADELPHIA PA
HIGH POWER HF AND NOISE CANCELLATION SYSTEM.(U)
MAR 80 S J HARRIS, S J ROSASCO
6AC-3392-3403-13

F/G 20/14

F30602-78-C-0338

UNCLASSIFIED

RADC-TR-80-56

NL

1 of 1

40

00000006

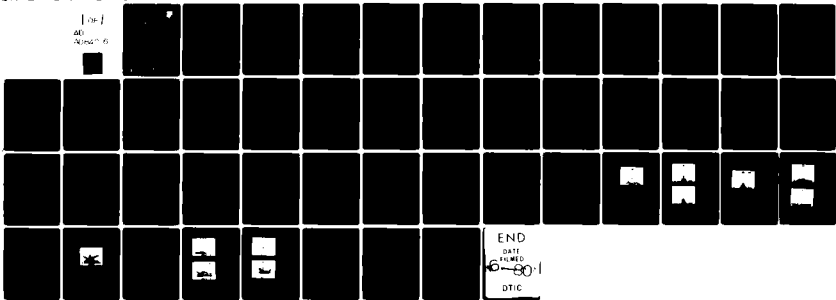

END
DATE
FILMED
6-80-1
DTIC

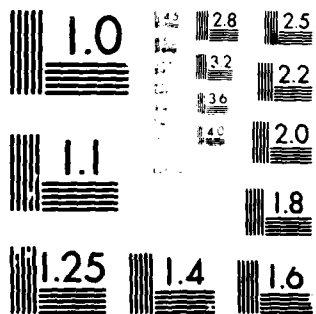

MICROCOPY RESOLUTION TEST CHART
NATIONAL BUREAU OF STANDARDS-1963-A

ADA084016

LEVEL VII



RADC-TR-80-56
Final Technical Report
March 1980



HIGH POWER HF AND NOISE CANCELLATION SYSTEM

General Atronic Corporation (Magnavox)

Samuel J. Harris
Dr. Stephen J. Rosasco

APPROVED FOR PUBLIC RELEASE; DISTRIBUTION UNLIMITED

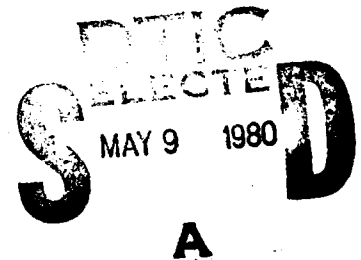

ROME AIR DEVELOPMENT CENTER
Air Force Systems Command
Griffiss Air Force Base, New York 13441

DDC FILE COPY

80 5 8 024

This report has been reviewed by the RADC Public Affairs Office (PA) and is releasable to the National Technical Information Service (NTIS). At NTIS it will be releasable to the general public, including foreign nations.

RADC-TR-80-56 has been reviewed and is approved for publication.

APPROVED:

Wayne E. Woodward

WAYNE E. WOODWARD
Project Engineer

APPROVED:

David C. Luke

DAVID C. LUKE, Lt Colonel, USAF
Chief, Reliability & Compatibility Division

FOR THE COMMANDER:

John P. Huss

JOHN P. RUSS
Acting Chief, Plans Office

If your address has changed or if you wish to be removed from the RADC mailing list, or if the addressee is no longer employed by your organization, please notify RADC (RBCT), Griffiss AFB NY 13441. This will assist us in maintaining a current mailing list.

Do not return this copy. Retain or destroy.

UNCLASSIFIED

SECURITY CLASSIFICATION OF THIS PAGE (When Data Entered)

19 REPORT DOCUMENTATION PAGE		READ INSTRUCTIONS BEFORE COMPLETING FORM
1. REPORT NUMBER 18) RADC-TR-80-56	2. GOVT ACCESSION NO. AD-A084 016 9	3. RECIPIENT'S CATALOG NUMBER
4. TITLE (and Subtitle) 6) HIGH POWER HF AND NOISE CANCELLATION SYSTEM		5. TYPE OF REPORT & PERIOD COVERED Final Technical Report Oct 78 - Jan 80
7. AUTHOR(s) 10) Samuel J. Harris Stephen J. Rosasco		6. PERFORMING ORG. REPORT NUMBER 3392-3403-13
9. PERFORMING ORGANIZATION NAME AND ADDRESS General Atronic Corporation (Magnavox) 1200 East Mermaid Lane Philadelphia PA 19118		8. CONTRACT OR GRANT NUMBER(s) 13) F30602-78-C-0338 new
11. CONTROLLING OFFICE NAME AND ADDRESS Rome Air Development Center (RBCT) Griffiss AFB NY 13441		10. PROGRAM ELEMENT PROJECT, TASK AREA & WORK UNIT NUMBERS 62702F 23380407 17) 04
14. MONITORING AGENCY NAME & ADDRESS (if different from Controlling Office) Same 12) 48		12. REPORT DATE 11) Mar 80
16. DISTRIBUTION STATEMENT (of this Report) Approved for public release; distribution unlimited		13. NUMBER OF PAGES 49
17. DISTRIBUTION STATEMENT (of the abstract entered in Block 20, if different from Report) Same 14) SAC-3392-3403-13		15. SECURITY CLASS. (of this report) UNCLASSIFIED
18. SUPPLEMENTARY NOTES RADC Project Engineer: W.E. Woodward (RBCT)		15a. DECLASSIFICATION/DOWNGRADING SCHEDULE N/A
19. KEY WORDS (Continue on reverse side if necessary and identify by block number) Electromagnetic Compatibility Communications HF/VHF/UHF Intermodulation		
20. ABSTRACT (Continue on reverse side if necessary and identify by block number) The objectives of this effort were achieved and should permit high power HF (2-30 MHz) transmitters and conventional HF receivers to be collocated on an aircraft and operated simultaneously (full duplex) with appreciably less than 10% frequency separation between the transmit and receive channels. The option of frequency assignment between the Maximum Usable Frequency (MUF) and the Lowest Usable Frequency (LUF) for the transmit and receive frequencies can result in a 40 dB improvement		

UNCLASSIFIED

SECURITY CLASSIFICATION OF THIS PAGE(When Data Entered)

in a duplex circuit, or stated another way, it may be the only way to establish a circuit between two points. One or more full duplex HF circuits can be operated simultaneously on an aircraft. The technique employed is a high power HF Interference Cancellation System which is adaptive and completely automatic.

The significance of this effort is that it has direct application to C_L³ aircraft and collocated ground HF sites, including those sites with transmitters of ultra high power output (>>1 kW). In addition, the ultra linear high power weight/controller technology employing goniometers can be applied in any frequency range from VLF to UHF.

UNCLASSIFIED

SECURITY CLASSIFICATION OF THIS PAGE(When Data Entered)

LIST OF ILLUSTRATIONS

1. Simplified System Block Diagram.....	6
2. Simplified Block Diagram of High Power Canceller.....	8
3. Goniometer Principle.....	9
A-1. Response of Feedback Control Loop.....	14
A-2. Servo Loop Block Diagram.....	17
4. Medium Power Canceller Block Diagram.....	24
5. Noise Canceller Simplified Block Diagram.....	27
6. Goniometer Tap.....	30
7. High Power Canceller.....	32
8. Cancelled Residue, High Power and Medium Power Canceller.....	33,34
9. Two-Tone Test - High Power and Medium Power Cancellers.....	35
10. Cancellation Notch Antenna VSWR 3:1 Prior to Matching at 2.2 MHz - High and Medium Power Cancellers.....	37
11. Cancellation Notch - High and Medium Power Cancellers.....	39
12. Pilot-Directed Noise Canceller Performance - Pilot Above Transmit Frequency.....	40

EVALUATION

The objective of this effort is to permit high power HF (2-30 MHz) transmitters and receivers to be collocated on an aircraft and operated simultaneously with appreciably less than 10% frequency separation between transmit and receive channels.

With transmitters and receivers operated as close as 100 kHz it is possible to choose frequencies between the Maximum Usable Frequency (MUF) and the Lowest Usable Frequency (LUF) for any two locations on earth. The option of frequency assignment between the MUF and the LUF can result in a 40 dB improvement in the duplex circuit, or stated another way, it may be the only way to establish a circuit between two points.

The significance of this HF effort is that it has direct application to C³ aircraft, reference R4C.1.b (U) EMC Interference Control of the TPO. In addition, the ultra-linear high power weights/controllers technology can be applied in any frequency region from VLF to UHF.

Wayne E. Woodward
WAYNE E. WOODWARD
Project Engineer

SECTION I

INTRODUCTION

1.1 BACKGROUND

Simultaneous transmission and reception at HF aboard aircraft is currently limited to frequency separations in excess of 10% by the selectivity achievable with preselectors. Without additional preselection simultaneous operation is impossible because the antenna isolation is insufficient to protect the receiver from excessive input power levels. (The transmit level at the receive antenna may be as high as 32 watts from a one kilowatt transmitter).

Preselectors are of little help when a number of receivers are to be used with an active multicoupler. Present practice is to short the receive antenna when a transmit antenna is energized. Means to minimize the transmitted signal together with the transmitted noise and spuri at the received frequency is required if normal reception is to be achieved. The permissible transmitter signal residue is dependent on the selectivity of the receiver as well as the level of the received signal. Data on the R-761/ARC-58 [1] receiver indicates that a signal removed at least 100 kHz from the received signal at a level below -18 dBm will not affect reception provided it does not fall on a spurious response. There are relatively few such responses below -18 dBm. The level, while arbitrary, is sufficient to permit operation under the majority of conditions. It is also low enough to permit operation with an active multicoupler.

A preselector permits reception when the frequency separation is greater than 10% and the transmitter noise and spuri are not excessive at the received frequency. Unfortunately, frequency offsets of 10% are often too great to permit long haul transmission within the bounds set by the minimum and maximum usable frequency.

An interference canceller is a logical choice for the suppression of the transmitted signal since its operation is independent of frequency offsets. The HF interference cancellation problem was investigated under Contract F30602-75-C-0107 [2]. A cancellation system is limited by the distortion products generated in the weights. The worst case is the cancellation of a two-tone SSB signal. In that system, the weights (controllers) were required to handle a two-tone signal of +39 dBm per tone. The third-order intercept of the weights is a function of frequency. The average value was +54 dBm which limited the (SSB) cancellation ratio to about 30 dB. In that system, the insertion loss was 8 dB, the minimum

[1] "Spectrum Signature of Radio Set AN/ARC-58," Technical Report ASD-TR-68-38, July 1968.

[2] "High Power Controller and ICS," Report RADC-TR-77-272, A044 757.

space loss between transmit and receive antennas was assumed to be 15 dB. The SSB transmit signal isolation at the receive port was 53 dB, which left an average residue of +7 dBm under the assumed conditions. The residue was 25 dB above the design goal. It also developed that the cancellation bandwidth is narrow because the match achievable, by the HF antenna coupler on an aircraft is narrowband. The single-loop canceller may cancel the transmitted signal adequately. It will afford little protection against transmitted noise and spurs.

RADC developed an electromechanically positioned goniometer canceller [3]. The cancellation ratio was greater than 50 dB over the 5 to 18 MHz bands. The acquisition time was 400 milliseconds.

The HF band is 2 to 30 MHz. Translating acquisition time to performance under aircraft dynamics is complicated. Since the servo-controlled system has position memory, initial acquisition can take place while the transmitter is tuning up, so that acquisition time is not critical. What is critical is how well the system can follow phase changes in the received interference due to in-flight changes in antenna coupling. It is not likely that the RADC model is sufficiently fast to follow such changes. Again, the problem is complex and the flight data skimpy. The problem increases with frequency since the relative phase change is a function of relative antenna motion. The maximum phase change at 30 MHz is believed to be less than $\pm 8^\circ$ (an 8° phase error limits achievable cancellation to 17 dB). If the cancellation were perfect steady-state, it would degrade to 17 dB at the maximum relative antenna excursions. The maximum frequency of the coupling variation measured 5 Hz in normal flight. Considering the size of the antenna structures, it is not likely that the frequency would be exceeded. The problem is to maintain 55 dB cancellation under dynamic conditions. If the system were to be entirely dependent on goniometer control, the tracking accuracy would have to be better than $\pm 0.1^\circ$ at rates of up to 250°/sec. On the other hand, if the cancellation task is split 20 dB electromechanically followed by 35 dB all-electronic, both systems are greatly simplified. The goniometer system only has to track within $\pm 6^\circ$ and the third-order intercept of the all-electronic weight can be as low as +36 dBm and still meet the design objectives. The combination of a high power goniometer canceller followed by a medium power electronic canceller should prove a logical solution to this complex problem.

[3] "A High Power Interference Cancellation System," NTC '77, 04-4-1.

1.2 PERFORMANCE OBJECTIVES

High Power HFICS and Adaptive Transmitter Noise Canceller

Frequency Range	2-30 MHz
Maximum interfering signal (F_0) level arriving at the receive antenna from the colocated transmitter	+45 dBm
Maximum Rate of Phase Change of received interference relative to transmitted signal after acquisition	250°/sec
Insertion Loss to the desired signal	8 dB max
Cancellation Residue interfering signal fundamental	-18 dBm max
Harmonics contributed by ICS to residue	-10 dBm max
Cancellation of transmitter noise in a 3 kHz band from $f_0 \pm 100$ kHz to $f_0 \pm 0.1f_0$	40 dB
AC power	115V @ 60 Hz

SECTION II

SYSTEM DESIGN CONSIDERATIONS

2.1 SYSTEM CONFIGURATION

The system consists of a servo-controlled goniometer ICS capable of reducing the interfering signal at the receiver port from +37 dBm to below +17 dBm under flight dynamics followed by a dual electronic canceller capable of maintaining the interference residue and the transmit noise at the receive frequency below the levels specified in Section 1.2.

The system block diagram is shown in Figure 1. Assume a transmitted signal level of +60 dBm and 15 dB space loss. The interference level at the receive antenna port is +45 dBm. The combined insertion loss and cancellation reduces that signal to less than +16 dBm while tracking a signal under (worst-case) flight conditions. The residue decreases under static conditions to a level determined by the loop gain of the canceller.

The servo-driven canceller is followed by a two-loop ICS. One loop is dedicated to cancelling the interfering signal and the other to cancelling the interfering noise at the receive frequency.

The references for the two cancellers are taken from the forward and reflected ports of a 20 dB bidirectional coupler in the transmission line. A pilot signal is injected into the transmission line at a 0 dBm level. There is a 10 dB loss between the weighted reference output of the medium power canceller and the output of the 7 dB coupler. so that the medium power canceller weighted reference power may be as high as +26 dBm PEP or +20 dBm per tone. In-band distortion products from the existing HFICS weights will be down 68 dB at this level. Distortion products will not limit performance.

The reference for the noise canceller loop is taken from the reflected port of the 20 dB bidirectional coupler. The design goal for the antenna coupler is an SWR of <1.25:1 at tune-up. Even if it degrades to 1.5:1 the reflected transmit signal will be 14 dB below the level at the forward port.

The SWR increases rapidly with frequency offset so that the ratio of the reflected pilot to transmit signal will always be greater than the incident ratio. The reference signal will always contain a transmit component <+26 dBm and a pilot component greater than -34 dBm. The ratio of the two signals will always be <60 dB.

The weighted reference from the pilot-directed noise canceller minimizes the pilot, and hence the noise in the vicinity of the pilot. The efficacy of this loop is dependent on the cancellation bandwidth of the other two loops, on the antenna coupler match and space loss. The

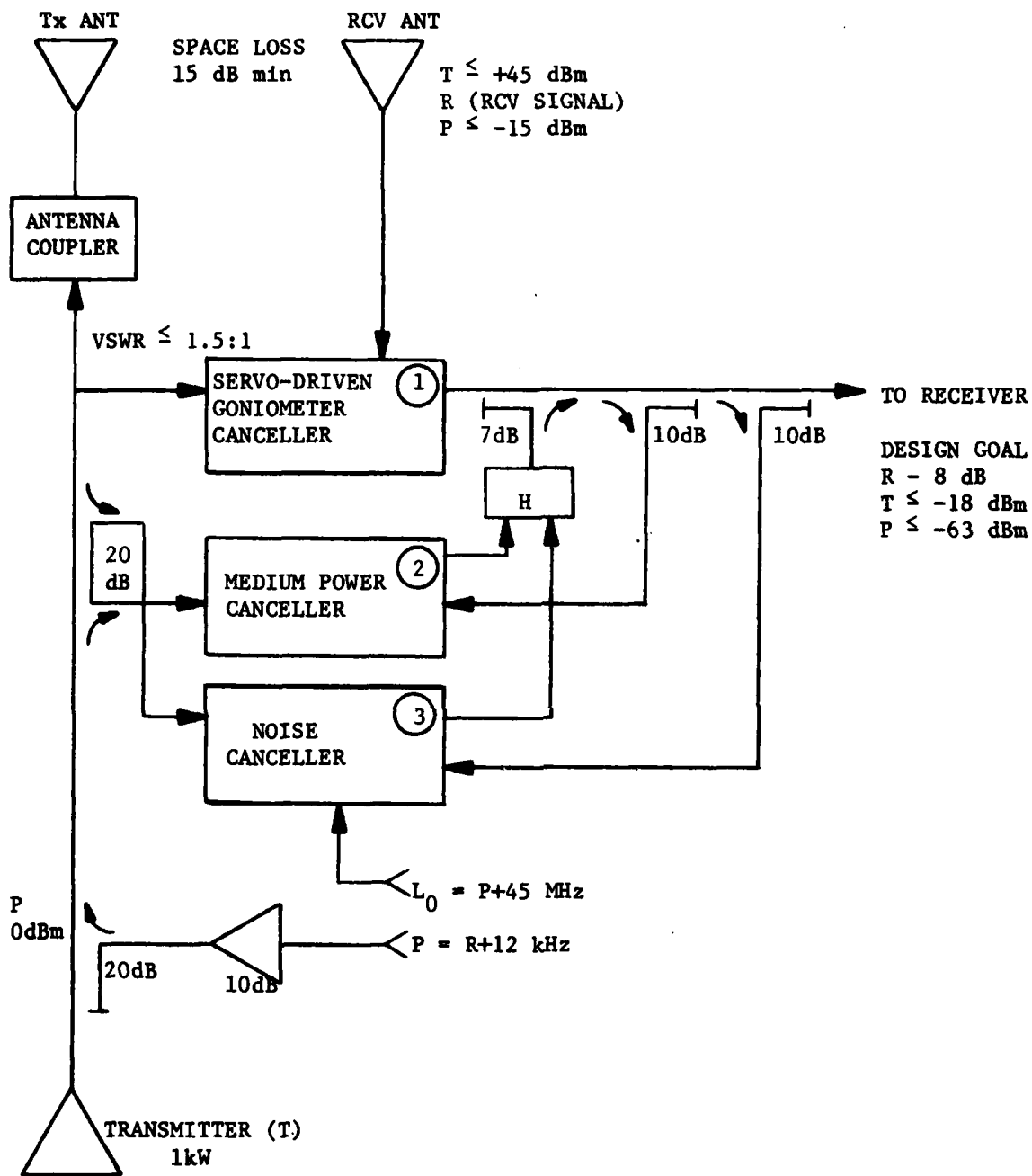

FIGURE 1
SIMPLIFIED SYSTEM BLOCK DIAGRAM

limitations are discussed in more detail in Section 2.4.3.

2.2 HIGH POWER CANCELLER (Figure 2)

The high power canceller differs from the techniques explored in the HFICS [2] in that the PIN diode bipolar attenuators are replaced by servo-driven goniometers. To cancel a +45 dBm interference at the receive antenna port, a +44 dBm signal is required at the output of each goniometer, allowing for 4 dB splitting loss and 2 dB insertion loss. The goniometer's coupling factor should be a minimum of 16 dB or should have the capability of delivering at least 25 watts to the quadrature hybrid at any frequency in the HF band.

2.2.1 The Goniometer Principle

The high power canceller is based on the goniometer -- a transformer in which the mutual inductance can be controlled in both magnitude and sign by mechanical rotation. The goniometer resembles a balun transformer with the core fabricated as two coaxial cylinders. Figure 3 shows cross-sections with the rotor in three positions.

Maximum coupling is shown at A. As the rotor rotates the coupling decreases B. At position C coupling is minimum. As the rotor continues to rotate, coupling increases but the phase reverses.

2.2.1.1 The High Power Controller

As shown in Figure 2, the high power controller consists of two servo-driven goniometers. The level at the output of each goniometer may be as high as +44 dBm/PEP or +38 dBm per tone with a two-tone interference. For 55 dB of cancellation the third-order intercept must be greater than +60.5 dBm. Sample goniometer tests have indicated that a +70 dBm I_3 is practical.

In this embodiment the goniometers are used as variable line taps. Only the power used is taken from the line. Since the maximum power required by the controller is 3.6% of the RF power (36 watts), the effect on a matched system is the same as if the load resistance were reduced 3.6%, i.e., the VSWR would be increased to 1.04:1. The canceller dissipates 36 watts worst-case.

If the line taps were to be replaced by a 13 dB coupler and in-phase splitter, the dissipation would be 5% of the RF power (50 watts), independent of the goniometer settings. For some applications, the directional coupler approach may prove preferable even though it absorbs more power.

The high power canceller acquires while the antenna coupler is tuning. Acquisition may be relatively slow. The system is required to follow changes in coupling between antennas which occur during flight. To permit tracking relatively fast changes, the goniometers are designed to be

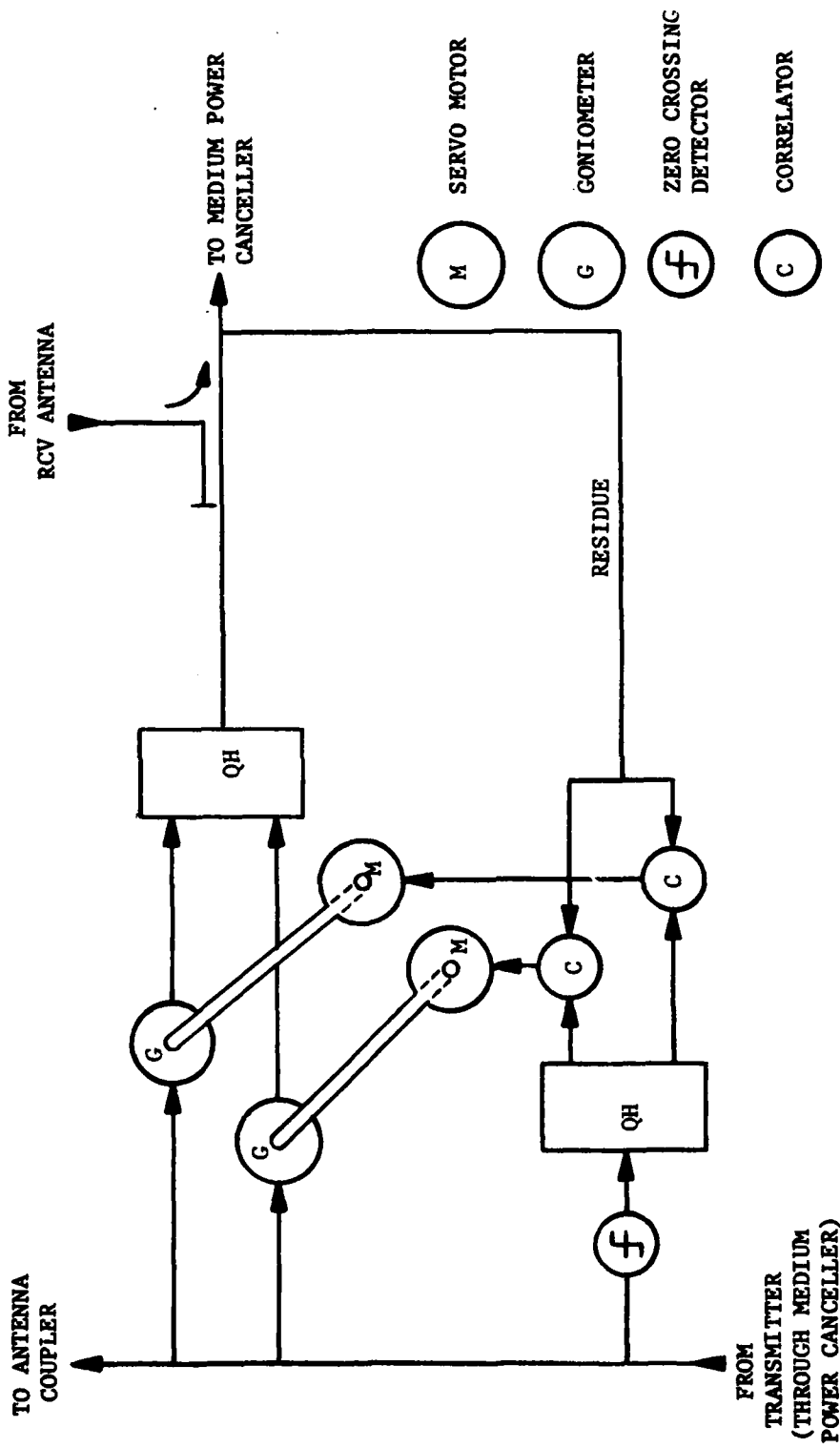
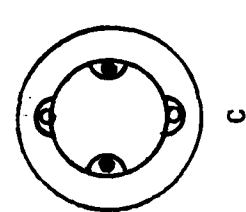
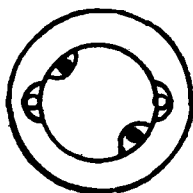

FIGURE 2
SIMPLIFIED BLOCK DIAGRAM OF HIGH POWER CANCELLER



C

WINDINGS
 ● ROTOR
 ○ STATOR



B

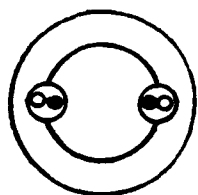

A

FIGURE 3
 GONIOMETER PRINCIPLE

low inertia-low friction devices. The mass and radius of gyration of the rotor are minimized. A rotary transformer is incorporated to eliminate contact friction.

The servo-driver forms an integral part of the system dynamics. The following is excerpted from the servo-system study made during the design phase. The requirements at that time were somewhat more severe than the overall system now indicates to be necessary. In particular, requirement I.B.a)* can be relaxed to permit a final settling position of 1.8° in lieu of 0.1° without degrading the overall system performance.

*Appendix to Section 2.2.

Appendix to Section 2.2

SUMMARY REPORT FOR GONIOMETER SERVO SYSTEM

I. INTRODUCTION

A. Object: To design a position servo system for minimum cost, short delivery and simplicity.

B. Requirements:

a) In response to step input presenting 90° angular displacement error, to settle and remain within 0.1° from desired null position in approximately 50 milliseconds.

b) To follow a sinusoidally varying error signal representing $\pm 12^\circ$ excursion from null at a rate of 5 Hz, and exhibit a following error of less than 1.8° from the desired instantaneous position as a desired goal.

c) The error signal to be a bipolar dc signal whose magnitude and direction are related to deviation from the desired null. Said signal is stipulated to have no dead zone and to have a slope of one (1) volt per degree for the first ten (10) degrees of error, and a bandwidth of several kilohertz.

II. STUDY

Study and tradeoffs were performed on ac/dc systems, Inertial Damped Motors, DC Torquers, regular dc motors and Moving Coil dc Motor-Tachometers.

A. AC System (400 Hz)

The use of the 400 Hz system was discarded due to:

1. High speed, low torque sensitivity, therefore gear train is required which introduces backlash. Gearheads, reasonably priced (\$150-\$200) have 0.3 to 0.5 degrees of backlash.

2. Low velocity constant obtainable, 120 to 150 per second without demodulation/modulation and compensation circuitry.

3. Possible saturation of the amplifier with tachometer's quadrature voltage.

4. High electrical time constant of the motor.

5. Gearheads with 0.1 degree of backlash cost \$600-\$1000.

B. Inertial Damped Servo Motors

This system approach was eliminated due to:

1. Low acceleration constant
2. Gear train requirements
3. Precise matching requirements of the load inertia to the motor inertia. For good matching, the flywheel inertia should represent 80% to 90% inertia to be controlled.

C. Regular DC Motor-Tachometer

The disadvantages of this system are:

1. Gear train required.
2. Low speed cogging.
3. Moderate (high) electrical time constant.

D. DC Torquer-Tachometer

DC torquer is ideal for this application due to its high torque sensitivity, low electrical time constant and a very high speed resolution.

The problem arises because it is a long-lead item and user must provide housing for it, which is quite expensive and tolerances must be tight.

E. Moving Coil Motor-Tachometer

This motor-tachometer was selected primarily due to its availability, low armature inertia, low electrical time constant, high acceleration torque, smooth, cogging-free output torque at any speed, moderate torque constant, and high mechanical resonance frequency of the motor-tachometer combination.

F. Type of Servo System

The Goniometer Servo System will be a type one system, consisting of its error detector (goniometer) amplifier and motor-generator. It will provide an accurate position to within 0.3525 degrees at maximum velocity of 377 degrees per second and maximum acceleration of 11832 degrees per second. The system will have velocity constant (K_V) of 1100 per second, acceleration constant (K_A) of 1210000 (minimum) per second squared and a phase margin of 45 degrees.

Internal loop compensation will be provided by velocity feedback obtained from a tachometer which is an integral part of the Servo Motor. The open loop gain vs frequency characteristic is shown in Figure A-1.

The static error will be 0.069° at 25°C and 0.101° when motor's winding temperature is 155°C . Static error is calculated for 33 VM 62-020-3 motor-tachometer and assumed total friction of 2 oz-in.

III. RECOMMENDATIONS

It is recommended that:

a) 33 VM 62-020-3 Motor-Tachometer be used (supplied by Microswitch, a division of Honeywell).

b) Servo Amplifier Model PA223 with nS200 and PC220 manufactured by Torque Systems.

c) Goniometer shaft to be direct-coupled to the Servo Motor shaft.

d) No flexible coupling to be used.

e) Coupling length (Goniometer/Motor Shafts) should be as short as possible.

f) Solid-tapered pin to be used after holes have been drilled in coupling and shafts.

g) Brake should not be considered at this time, because motor's (brushes) friction torque of one (1) oz-in might be sufficient to prevent the armature and goniometer rotor from rotation when there is no power applied to the motor.

h) Goniometer rotor should be carefully balanced.

i) Input to the Servo amplifier should be grounded when not in use (immobilizing signal).

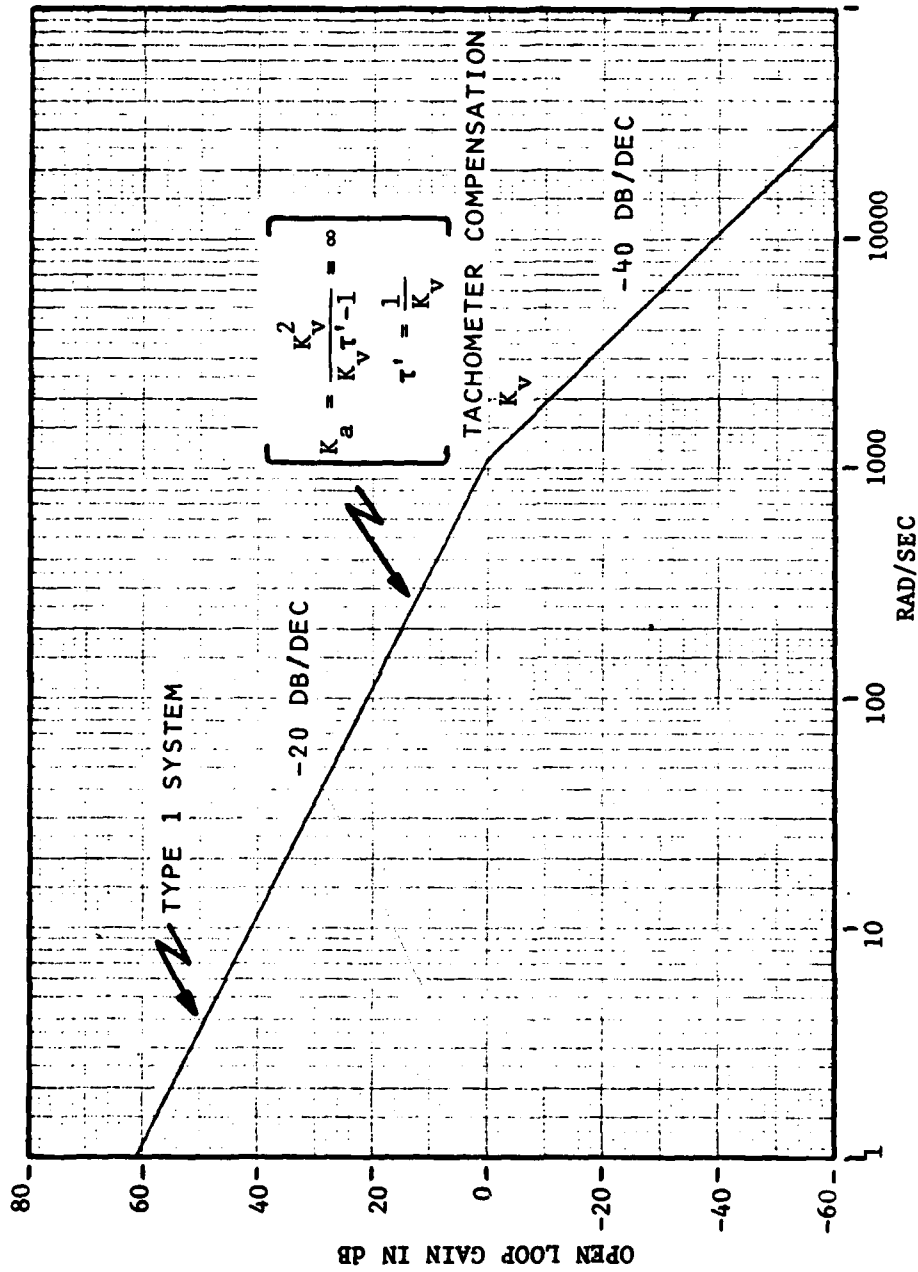

FIGURE A-1
 RESPONSE OF FEEDBACK CONTROL LOOP

Servo System Transfer Function and Time Constant

1. The electrical time constant of the motor will be neglected at this time. It has an effect on tachometer loop; therefore, after determination of amplifier gain and tachometer feedback constant K_G , the minor loop will be checked for stability.

2. The time constant of the servo amplifier will be neglected at this time, since it is a function of amplifier gain which will be determined later.

Relationship between K_V (Velocity Constant) and K_2 (Acceleration Constant) for this system.

Since this system must follow sinusoidal inputs, one must consider velocity and acceleration constants to meet dynamic requirements; therefore,

$$\text{Total Dynamic Error } \varepsilon = \frac{|\dot{\theta}|}{K_V} + \frac{|\ddot{\theta}|}{K_2}$$

where $|\dot{\theta}|$ = maximum velocity; $|\ddot{\theta}|$ = maximum acceleration.

Theoretically, for this type of system (because we will force it to be)

$$K_2 = \frac{K_V^2}{K_V \tau' - 1}$$

We will make $\tau' = 1/K_V$. Therefore,

$$K_2 = \frac{K_V^2}{K_V \frac{1}{K_V} - 1} = \frac{K_V^2}{0} = \infty$$

In practice, K_2 will be somewhere between K_V^2 and ∞ .

Assume (given)

$$\theta = 12^\circ \sin 2\pi f t \quad f = 5 \text{ Hz}$$

$$= 12 \sin 31.4 t$$

$$|\dot{\theta}|_{\max} = 12 \times 31.4 = 377^\circ/\text{sec} = 6.6 \text{ rad/sec} \approx 63 \text{ rpm}$$

$$|\ddot{\theta}|_{\max} = 12(31.4)^2 = 11832^\circ/\text{sec}^2 = 206.5 \text{ rad/sec}^2$$

Therefore:

for 0.1° error

for 1.8° error

$$(1) K_V = \frac{\dot{\theta}}{0.1^\circ} = \frac{377}{0.1} = 3770 \text{ sec}^{-1}$$

$$(2) K_V' = \frac{377}{1.8} = 209.4 \text{ sec}^{-1}$$

$$(3) K_2 = \frac{\ddot{\theta}}{0.1^\circ} = \frac{11832}{0.1^\circ} = 118320 \text{ sec}^{-2}$$

$$(4) K_2 = \frac{118320}{0.1^\circ} = 6573 \text{ sec}^{-2}$$

Let us see if we can obtain velocity constant $K_V = 3770 \text{ sec}^{-1}$.
The open loop transfer function of Figure A-2 is

$$\frac{\theta_0(s)}{E_1(s)} = \frac{\frac{K_S K_a}{K_B}}{s(S\tau_M + 1 + \frac{K_a K_G}{K_B})} \quad (5)$$

We will make the following initial assumptions:

$$K_M = 25 \text{ rad/sec/V}$$

$$\tau_M = 4.5 \times 10^{-3} \text{ sec}$$

$$1/K_B = K_M = 25$$

Therefore,

$$\begin{aligned} \frac{\theta_0(s)}{E_1(s)} &= \frac{K_S K_a K_M}{s(S\tau_M + 1 + K_M K_a K_G)} \\ &= \frac{25 K_S K_a}{s(S\tau_M + 1 + 25 K_a K_G)} \\ &= \frac{25 K_S K_a}{1 + 25 K_a K_G} \\ &= \frac{\tau_M}{s(\frac{\tau_M}{25 K_a K_G + 1} + 1)} \end{aligned} \quad (6)$$

From Equation (6)

$$K_V = \frac{25 K_S K_a}{1 + 25 K_a K_G} \quad (7)$$

$$\tau' = \frac{\tau_M}{25 K_a K_G + 1} \quad (8)$$

$$= \frac{4.3 \times 10^{-3}}{25 K_a K_G + 1} \quad (9)$$

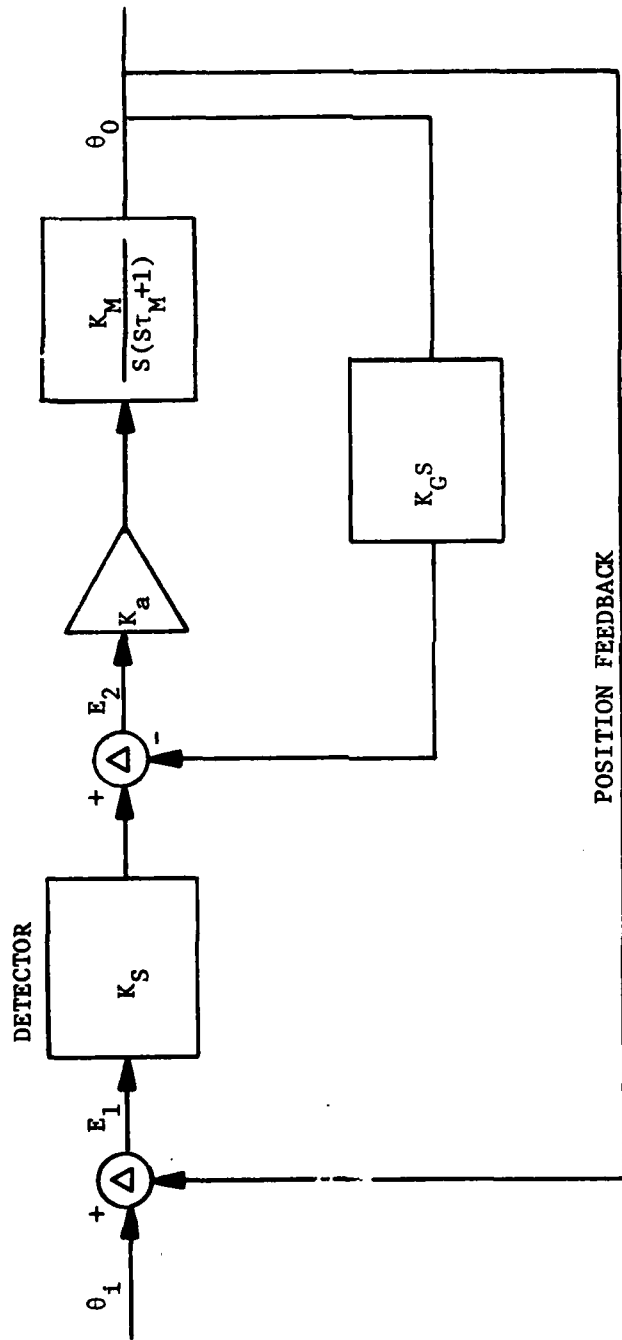

FIGURE A-2
SERVO LOOP BLOCK DIAGRAM

For 45° phase margin. (damping ratio $\rho = 0.5$)

$$K_V \tau' = 1 \quad (\text{we are forcing it to be})$$

$$\tau' = \frac{1}{K_V} = \frac{1}{3770} = 2.65 \times 10^{-4} \text{ sec}$$

but

$$\tau' = \frac{\tau_M}{25K_a K_G + 1}$$

Therefore,

$$25K_a K_G \tau' + \tau' = \tau_M$$

Substituting τ' and τ_M

$$K_a K_G = 63.9 \times 10^{-2} \quad (10)$$

From Equation (7)

$$3770 = \frac{25K_a K_S}{25K_a K_G + 1} = \frac{25K_a K_S}{25 \times 63.9 \times 10^{-2} + 1} = \frac{25K_a K_S}{16.975}$$

Therefore,

$$63995 = 25K_a K_S = 238.75K_a$$

but

$$K_S = 9.55 \text{ V/rad}$$

Therefore,

$$K_a = 268 \text{ V/V} \quad (11)$$

From Equation (10)

$$268K_G = 63.9 \times 10^{-2}$$

$$K_G = 2.384 \times 10^{-3} \text{ V/rad/sec} \quad (12)$$

Since we have ignored electrical time constant of the motor, let us consider it now and see if minor loop (tachometer loop) is stable. The tachometer loop will be stable if

$$\begin{aligned} K_G &\leq \frac{K_B \tau_M}{2\tau_E K_a} & K_G &= 2.384 \times 10^{-3} & (13) \\ &\leq \frac{0.04 \times 4.5 \times 10^{-3}}{2 \times 1.29 \times 10^{-4} \times 26.8} \\ &\leq \frac{1.8 \times 10^{-4}}{6.9 \times 10^{-3}} = 2.6 \times 10^{-2} \end{aligned}$$

Theoretically, the tachometer loop is stable.

Modifications to Calculations for 33VM62-020-3
Motor Tachometer

$$I \text{ (Motor-Tach)} = 58 \times 10^{-5} \text{ oz-in-sec}^2$$

$$I_L \text{ (Dynamometer)} = 57 \times 10^{-5} \text{ oz-in-sec}^2$$

$$I_{\text{TOTAL}} = 115 \times 10^{-5} \text{ oz-in-sec}^2$$

Therefore,

$$\tau_M = \frac{R_T I_T}{K_B K_T} = \frac{3.5 \times 115 \times 10^{-5}}{0.082 \times 11.6} = 4.23 \times 10^{-3} \text{ sec}$$

$$K_M = \frac{1}{K_B} = \frac{1}{0.082} = 12.2 \text{ rad/sec/volt}$$

Modifying Equations (7) and (8)

$$\tau' = \frac{\tau_M}{12.2 K_G K_a + 1} = \frac{4.23 \times 10^{-3}}{12.2 K_G K_a + 1}$$

$$K_G K_a = 0.30438$$

$$K_V = \frac{12.2 K_a K_S}{12.2 K_a K_G + 1}$$

Therefore,

$$K_a = 44.5$$

$$K_G = 6.84 \times 10^{-3} \text{ V/rad/sec}$$

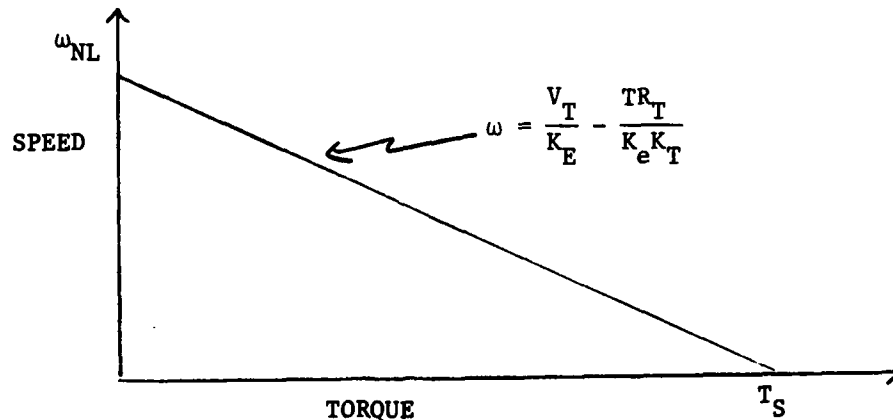

where

ω_{NL} = no load speed

T_S = stall torque for a given voltage

Since, at this time, we do not have torque/speed curve for this motor, let us calculate stall torque so that we can see what the static error (due to friction) will be.

The slope of the above line is

$$\omega = \frac{V_T}{K_e} - \frac{TR_T}{K_e K_T}$$

where ω = speed of the motor

K_e = back EMF (V/1000 rpm)

T = torque developed by motor at given speed

R_T = terminal resistance (motor + amp)

K_T = torque sensitivity

Let $\omega = 0$; then T becomes T_S (stall torque) and the above equation becomes

$$T_S = \frac{K_T V_T}{R_T}$$

$$R_T = 3 \text{ @ } 25^\circ\text{C}$$

$$= 4.33 \text{ @ } 155^\circ\text{C}$$

and maximum V_T from amplifier is 20 VDC. Therefore,

$$T_S = \frac{11.6 \times 20}{3} = 77 \text{ oz-in}$$

25°C

$$T_S = \frac{11.6 \times 20}{4.33} = 53.6 \text{ oz-in}$$

155°C

$$T_{KN} = T_S / V_T$$

$$T_{KV} = \frac{77.3}{20} = 3.865 \text{ oz-in/V}$$

25°C

$$T_{KV} = \frac{53.6}{20} = 2.68 \text{ oz/in/V}$$

155°C

System torque sensitivity:

$$K_{TS} = K_S K_a K_{TV}$$

where K_{TS} = system torque sensitivity in oz-in/deg

K_S = detector (goniometer) sensitivity in V/deg

K_a = amplifier voltage gain

K_{TV} = torque sensitivity in oz-in/volt

Therefore, static error due to friction is

$$\epsilon_{ST}^{25^{\circ}C} = \frac{F_L}{K_S K_a K_{TV}} = \frac{2}{0.166 \times 44.5 \times 3.865} = 0.069 \text{ deg.}$$

$$\epsilon_{ST}^{155^{\circ}C} = \frac{2}{0.166 \times 44.5 \times 2.68} = 0.101 \text{ deg.}$$

Calculations for step input of 90° to the Servo System:

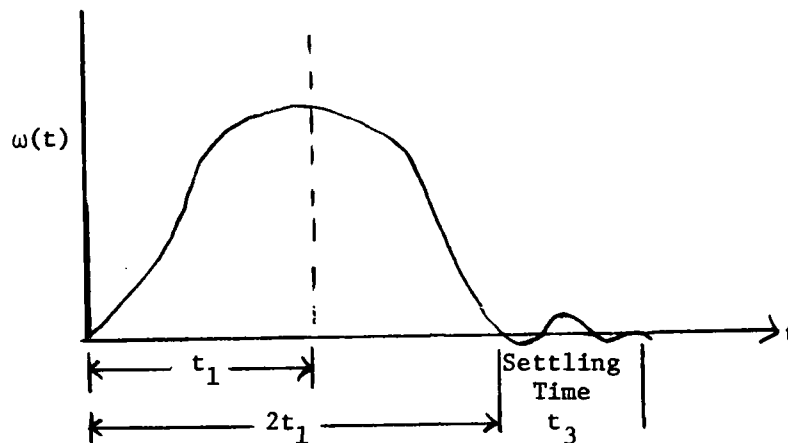

where $t_1 = 10 \text{ ms}$

$t_3 = 10 \text{ ms}$

The equation of motion for the servo system is:

$$T_S - T_F - D = I \frac{d\omega}{dt}$$

where T_S = stall torque of the motor

D = damping oz-in/rad/sec

T_F = system friction oz-in

$\theta = \pi/2$ radians

Solving the above equation and assuming $\omega=0$ at $t=0$,

$$\omega(t) = \frac{T}{D} \left[1 - e^{-\frac{D}{I}t} \right]$$

but $\omega = \frac{d\theta}{dt}$

Therefore,

$$\frac{d\theta}{dt} = \frac{T}{D} \left[1 - e^{-\frac{D}{I}t} \right]$$

$$\theta(t_1) = \int_0^{t_1} \frac{T}{D} \left[1 - e^{-\frac{D}{I}t} \right] dt$$

$$\theta(t_1) = \frac{T}{D}t_1 - \frac{TI}{D^2}\left[1 - e^{-\frac{D}{I}t_1}\right]$$

For this system $D = \frac{77}{244} = 0.32$ oz-in/rad/sec

$$T = 76 \text{ oz/in}$$

$$t_1 = 10 \text{ ms}$$

Then $\theta(t_1) = 1.525$ rad in 10 ms

$$\theta(2t_1) = 3.5 \text{ rad}$$

Therefore,

$$3.5 \text{ rad} \gg \pi/2 \text{ rad}$$

and the system is well within specifications.

2.3 MEDIUM POWER CANCELLER

The medium power canceller is designed to cancel the residue left by the high power canceller to a level of -18 dBm maximum at the receive port. Since the residue may be as high as +16 dBm at the output of the high power canceller, the residue must be reduced another 34 dB.

The insertion loss budget for the high power canceller is 7 dB, leaving 1 dB for the combined medium power and noise canceller. As shown in Figure 4, the medium power and noise canceller weighted references are first combined in a 3 dB hybrid and then summed with the output of the high power canceller by means of a 7 dB directional coupler. The weighted reference out of the medium power canceller may be as high as +26 dBm or 34 dB below the transmitted signal level (1 kW transmitters are assumed for all power level calculations).

The 34 dB difference is made up by the 20 dB coupler and the padded weight within the medium power canceller. Experience with HFICS [2] indicated that the correlation procedure used in that model was not well adapted to the wide dynamic modulation range inherent when the interfering signal modulation is SSB. The unit described in the report used high level mixers as correlators. Such a correlator has a dynamic range limited on the high end by diode burn-out and on the low end by the mode switching voltage. The range over which correlation is linear with error signal is about 12 dB below the maximum usable reference signal. The output of the correlator is dependent on both the transmitter signal level and the modulation format. In the HFICS, there was provision for optimizing the correlator reference level at installation.

In this implementation, the correlator reference is obtained from a zero crossing detector. The output of the detector is independent of the input level over a range exceeding 40 dB. The linear range of correlator operation is essentially independent of modulation format. The ICS performance with the new design is less dependent on modulation format.

Long pauses in voice modulation can pose particularly severe problems. The transmitter output drops to zero during such pauses and the ICS control loops stop tracking. On a dynamic platform, the phase of the interfering signal changes with time so that even if the weights were to be frozen during periods of zero modulation, reacquisition would be necessary when modulation is resumed. There are two approaches to the problem. The most desirable would be to modulate the transmitter with a low level signal outside the audio passband. The signal should be just sufficient in amplitude to maintain cancellation while the transmitter is energized but not modulated. Unfortunately, such an approach is beyond the scope of this effort. The approach chosen is to adjust the loop time constant as a compromise between the short time constant required to minimize interference during acquisition and the longer time constant desirable to optimize loop stability. It is anticipated that the final optimization of the time constant will be done during flight testing.

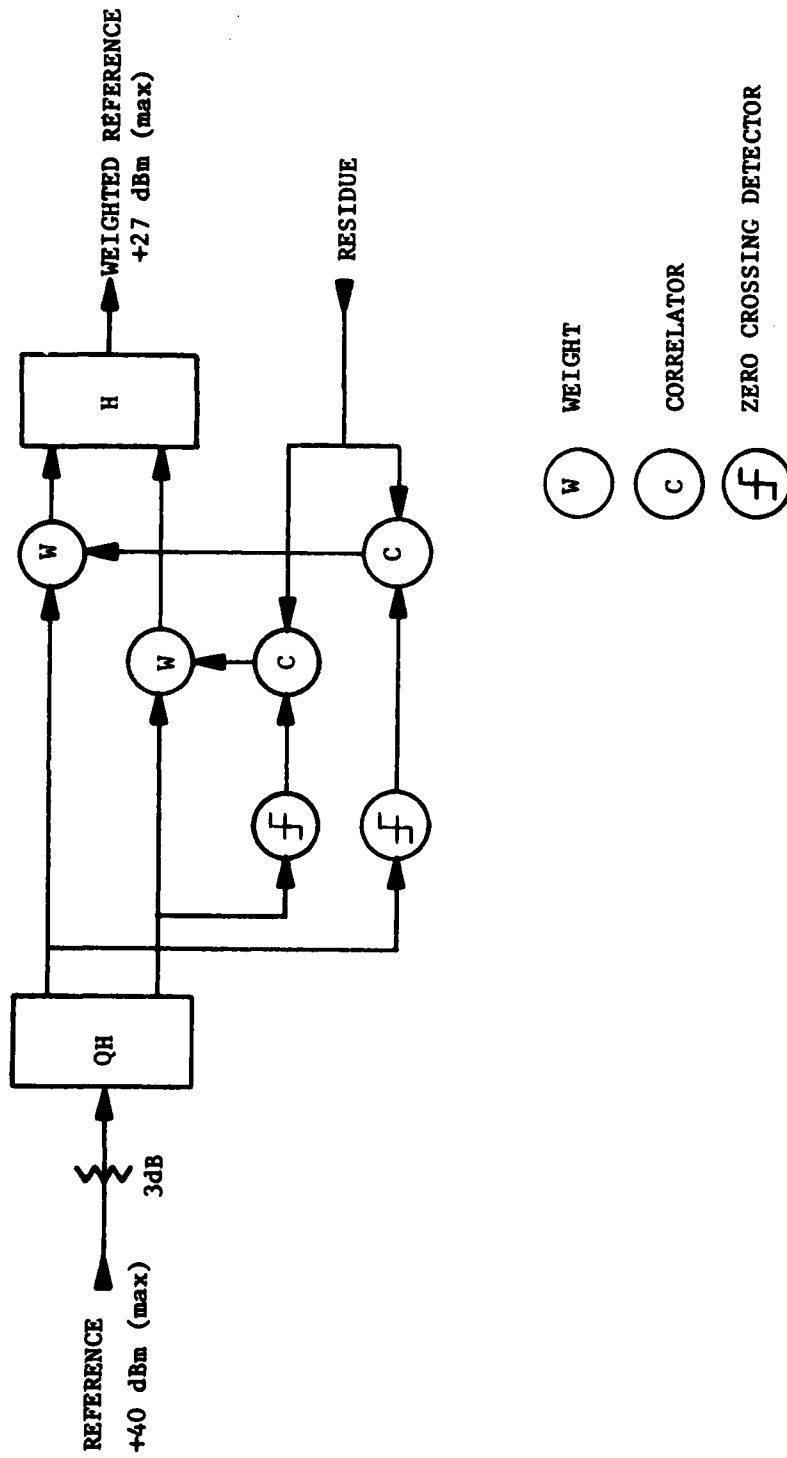

FIGURE 4
MEDIUM POWER CANCELLER BLOCK DIAGRAM

Figure 4 is a simplified block diagram of the medium power canceller. The reference comes from the forward port of a 20 dB bidirectional coupler on the RF transmission line. The 3 dB pad serves to improve the coupler match (the weights only approximate an impedance of 50 ohms).

The reference is split into quadrature components. Taps on the quadrature components feed zero crossing detectors. The zero crossing detectors furnish reference signals for the correlators which are relatively independent of the transmitted signal level. The quadrature reference components are weighted by PIN diode bipolar attenuators, combined in a 3 dB hybrid to form the medium power weighted reference. The cancelled residue at the receive port is sampled to furnish the error signal for the correlators. The correlators drive the weights. The weights and their drivers are described in detail in [2].

2.4 NOISE CANCELLER

The noise canceller loop is pilot-directed to null a section of the transmitted interference in the vicinity of the desired signal. The pilot signal is injected close to but outside the receiver IF passband so that the pilot residue will not limit reception (Figure 1).

The antenna coupler together with the antenna form a filter with minimum insertion loss at the transmitted frequency. To a first approximation the energy that is not transmitted through such a filter is reflected back toward the transmitter. The antenna coupler insures that the SWR is less than 1.5:1 so that the reflected transmit signal at the reference input to the noise canceller is always at least 14 dB less than the transmit signal to the medium power canceller.

The pilot-to-maximum transmit signal ratio is -60 dB at the references for both the medium and high power weights. At the noise canceller weight the ratio is the same when the pilot is close to the transmitted signal. As the pilot moves away from the transmit frequency, the SWR at the pilot frequency increases and the reflected pilot level increases. The ratio of pilot-to-maximum transmit signal increases towards a limit of -44 dB. It is this increase in pilot-to-transmit signal in the noise loop over that ratio in the medium power loop which permits simultaneous cancellation notches at the transmit and receive frequencies.

The noise canceller weighted reference is amplified so that the minimum loss through the noise canceller is 0 dB. When the pilot lies within the transmit cancellation notch, part of the noise cancellation is effected by the transmit canceller. The remainder is furnished by the noise canceller loop. The successful operation of the noise cancellation loop depends on sufficient pilot reference power to cancel the pilot residue remaining after the medium power canceller has cancelled the transmit signal. The pilot residue is dependent on the cancellation notch shape which, in turn, is dependent on the frequency dependence of the impedance match at the antenna coupler.

In the initial design, the weighted noise reference signal is amplified 10 dB to obtain reference margin for predicted operating conditions. If the margin proves inadequate in test, it can be increased. It should be noted that the additional amplification must be sufficiently linear so that it does not increase the overall system distortion.

The system approach to the noise canceller loop is to control the pilot-directed weights by correlating at IF. The IF filters are narrowband crystal filters with sufficient selectivity to reject the transmit residue even though the transmit signal may be initially 60 dB greater than the pilot signal. (Note that only the correlator reference and error signals are translated to a fixed IF frequency; the RF signal is not altered.)

Figure 5 is a simplified block diagram of the noise cancellation loop. The reference signal is taken from the reflected port of the 20 dB bidirectional coupler on the transmission line (Figure 2). The reference is split into quadrature components. The reference for correlation is tapped after the quadrature hybrid because the insertion phase of the hybrid is frequency dependent. The quadrature components of the reference signal are weighted, summed, and amplified to form the weighted reference.

Correlation takes place at 45 MHz. An LO signal 45 MHz above the pilot upconverts both the reference tap pilot and the error tap pilot to 45 MHz. Narrowband crystal filters isolate the pilot signal from the transmit signal. The filtered signals are amplified. A zero crossing detector reduces the dependence of the correlator reference on the reflected pilot level (the level may vary 14 dB). The output of the zero crossing detector is split into quadrature components to form reference signals for the two correlators. The correlator outputs drive the weights to complete the loop.

SECTION III
PERFORMANCE MEASUREMENTS

3.1 GONIOMETER CHARACTERISTICS

3.1.1 Frequency Response

The maximum power required from the goniometer tap is 16 dB below the transmitted signal. Figure 6 shows the tap power at minimum insertion loss with and without compensation. Without compensation, the curve approximates a single-pole lowpass filter with a cutoff at about 12 MHz. The implication is that the frequency response is due to leakage reactance inherent in the goniometer construction (a ferrite balun transformer does not exhibit the droop). With compensation, the tap variation with frequency is 3.5 dB; without compensation the variation is 7 dB.

The compensated goniometer is sufficiently flat to be usable as a control element over the four octave HF band.

3.1.2 Power Handling

The goniometer was operated as a line tap over the HF band at power transfers up to 80 watts without significant heating. Maximum power transfer will not normally exceed 25 watts PEP. The average power will normally be far less.

3.1.3 Distortion

The design goal for the third-order intercept for the goniometer is +60.5 dBm. To determine the third-order intercept the signals from two transmitters set at 3703 kHz and at 4395 kHz were filtered and then combined with a 3 dB hybrid. The signal levels were set so that the power out of the goniometer was 10 watts per tone (+46 dBm PEP). The inband distortion products from the test system were over 70 dB below the tones. With the goniometer, the worst-case intermod was -59 dB ($I_3 = +69.5$ dBm). The larger RADC design measured +65 dBm in the same test.

For comparison, the highest I_3 measured with the PIN diode weights (worst-case attenuation) was +54 dBm. The goniometer can handle about 30 times the power for the same distortion as the PIN diode weights developed for the HFICS [2].

3.1.4 Goniometer Loop Response

The acquisition time of the high power canceller is measured by setting the goniometers so that the interference is uncancelled and then recording the time to cancel 8.7 dB (one neper). The time averaged 12 milliseconds. In this system, the high power canceller must achieve 22 dB

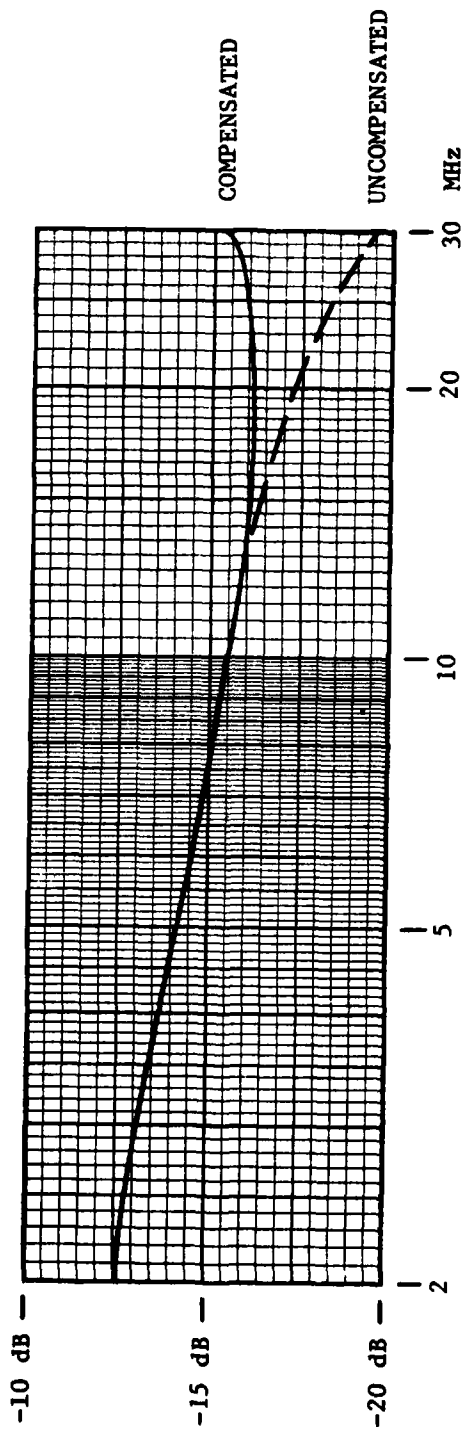

4:1 STEP DOWN
20 pF COMPENSATION

FIGURE 6
GONIOMETER TAP FREQUENCY RESPONSE

of cancellation prior to initiation of the medium power canceller. Starting from a completely uncanceled position, 30 milliseconds would be required before the medium power loop starts to function. In actual practice the high power loop acquires during transmitter tune-up. After initial tune-up, reacquisition time will be far less than 30 ms unless the coupling between the antennas changes drastically before the transmitter is reenergized.

3.1.5 Cancellation Depth

The high power canceller is designed to cancel down to a residue of +16 dBm at the receive port rapidly and then to continue to cancel down to about 0 dBm. (With the transmitter at full power the medium power canceller cuts in at +16 dBm and cancels the residue below -18 dBm.) Figure 7 shows that the performance of the high power canceller meets the design goal. It should be noted that the high power canceller is designed to operate in series with a medium power high speed canceller. If it were to be configured for a ground installation, the canceller could be reconfigured to reduce the residue sufficiently to permit the high power canceller to function alone.

3.2 HIGH POWER AND MEDIUM POWER CANCELLER

3.2.1 CW Interference

The design goal for the two loops cascaded is to maintain the cancelled residue level below -18 dBm at the receive port with 15 dB isolation between the transmit and receive antennas.

Spot checks were made across the HF band with the high power canceller alone and with the high and medium power canceller cascaded. A 1 kW CW interference with 15 dB isolation between transmit and receive ports is used in these tests.

<u>Frequency</u>	<u>Residue (dBm)</u>	
	<u>High Power Cancellor</u>	<u>Complete System*</u>
3.3 MHz	+6	-26
15	+6	-28
26	0	-34

Figure 8 shows the residue after cancellation for the three conditions. The uncanceled signal for the upper two photographs is +35 dBm. At 26 MHz, the test transmitter power was down 1.5 dB so that the uncanceled signal would be +33.5 dBm.

*Similar tests with a single loop all-electronic canceller resulted in suppressing the CW interference below -7 dBm [2].

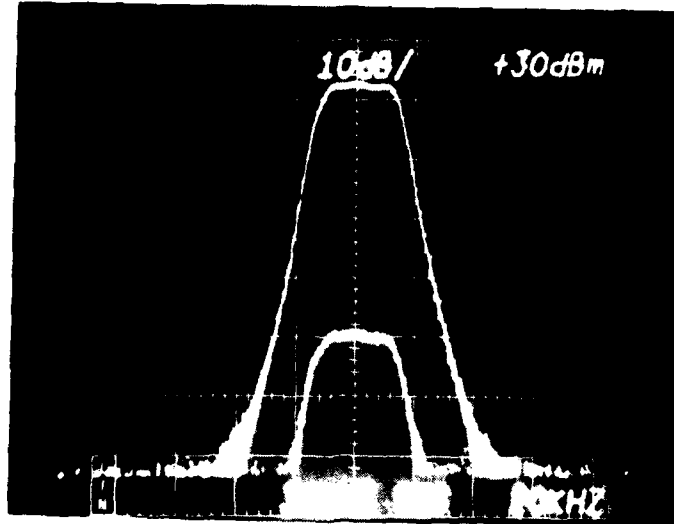

Uncancelled Residue +38 dBm
Cancelled Residue -4 dBm

FIGURE 7

HIGH POWER CANCELLER

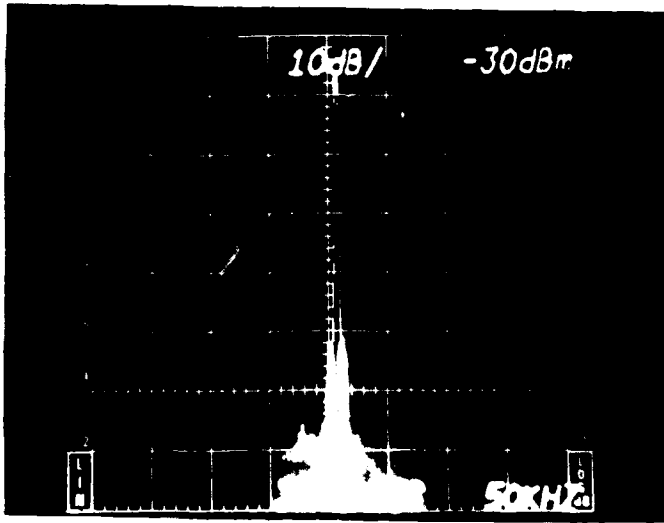

A

$P_{IN} = 1 \text{ kW}$
 at 4.5 MHz.
 Top Reticule
 is -20 dBm

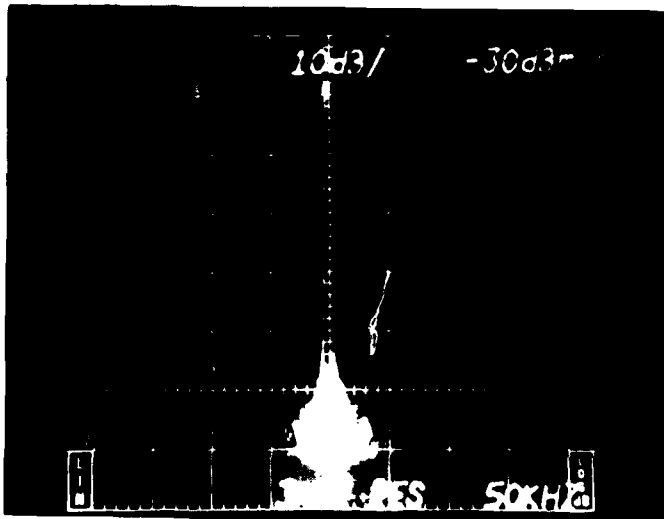

B

$P_{IN} = 1 \text{ kW}$
 at 15 MHz.
 Top Reticule
 is -20 dBm

FIGURE 8
 CANCELLED RESIDUE, HIGH POWER AND MEDIUM POWER CANCELLER
 CW INTERFERENCE

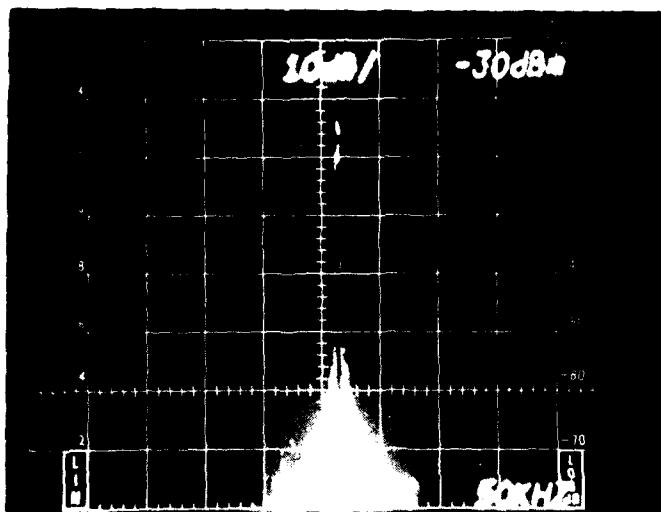

C

$P_{IN} = 800W$
at 27 MHz.
Top Reticule
is -20 dBm

FIGURE 8 (continued)

CANCELLED RESIDUE, HIGH POWER AND MEDIUM POWER CANCELLER
CW INTERFERENCE

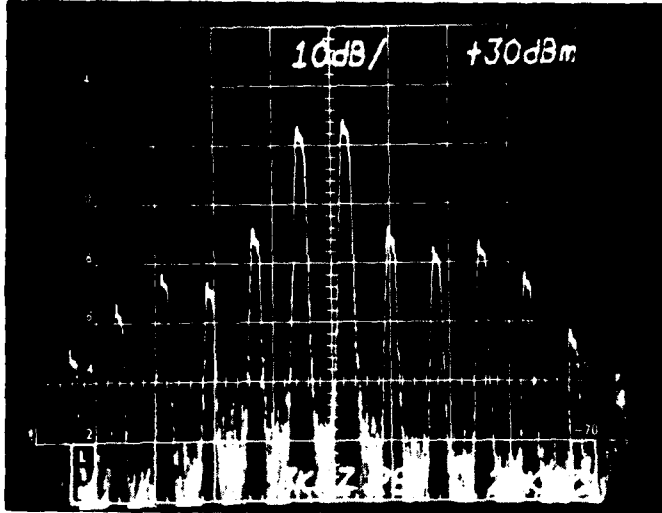

Top Reticule
is +46 dBm

(A) UNCANCELLED

+60 dBm PEP

Tones: 17 MHz, 250W
17.017 MHz, 250W

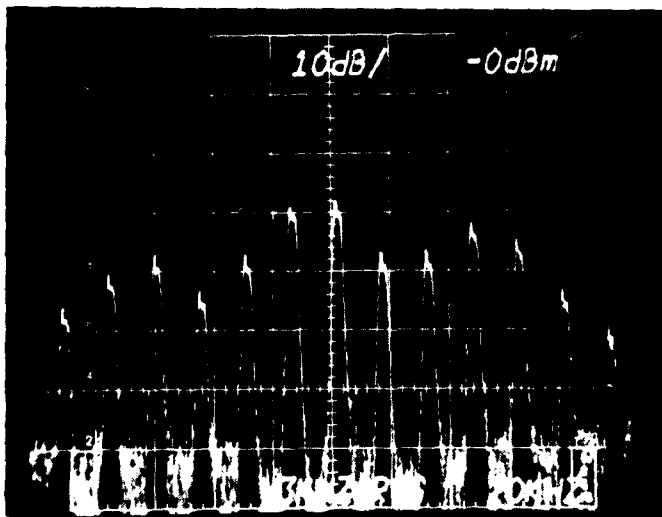

Top Reticule
is 0 dBm

(B) CANCELLED

FIGURE 9

TWO-TONE TEST - HIGH POWER AND MEDIUM POWER CANCELLERS

3.2.2 SSB Two-Tone Interference

For this test the interference is +60 dBm PEP. The signal consists of two +54 dBm tones spaced 17 kHz apart. The test driver for the transmitter is nonlinear as shown in photo A. The distortion products are only 18 dB down. In photo A, the two tones are +30 dBm each prior to cancellation. After cancellation, they are -28 dBm each. The total cancellation residue is -25 dBm* which compares favorably with the CW residue.

In photo B the third-order distortion products are -36 dBm* or 66 dB below the uncancelled +30 dBm tone. The third-order intercept (I_3) referred to the receiver port of the system is +66 dBm. While the actual source or sources of distortion have not been identified, it should be noted that the loss from each goniometer to the receiver port is 6 dB. The measured I_3 of the goniometer is +69.5 dBm which translates to +63.5 dBm at the receive port. The results are within experimental error.

3.3 NOISE CANCELLER

The noise loop requires further refinement. Operation is currently limited to frequency offsets with small return loss for the pilot and space losses sufficient to negate the need for the high power canceller. Data is shown to illustrate the soundness of the noise canceller principle as well as some of its limitations.

The noise canceller operation is based on the premise that cancellation is bandlimited by virtue of the transfer function imposed by the antenna coupler and antenna. If this is the primary reason, then weighting both the forward and reflected portion of the transmitted signal will result in relatively broadband cancellation. To test this premise a mismatched antenna was simulated by paralleling three 50-ohm terminations for an SWR of 3:1. (The actual antenna SWR varies with antenna type and frequency. In general, the SWR will exceed 3:1 and cancellation without the pilot-directed loop will be narrower than shown in these tests.) A Collins-type 180S-1 manual canceller is tuned to reduce the SWR at the transmit frequency to below 1.5:1. The antenna couplers aboard aircraft are designed to tune to 1.25:1 or better. Figure 10 shows the cancellation notch achieved at 7.2 MHz under these conditions. The cancellation notch depth at $f_0 \pm 10\%$ has deteriorated to 10 dB. The noise canceller loop is designed to increase the depth of the cancellation notch at the receive frequency. The noise cancellation notch is pilot-directed. (A low level swept probe signal is used to measure the cancellation notch characteristic.)

As implemented, the noise canceller loop will not function with the high power loop. For the following tests, the high power loop was disabled and the isolation between antennas increased from 15 to 41 dB.

*A similar test with a single-loop all-electronic canceller resulted in a cancellation residue about 0 dBm [2].

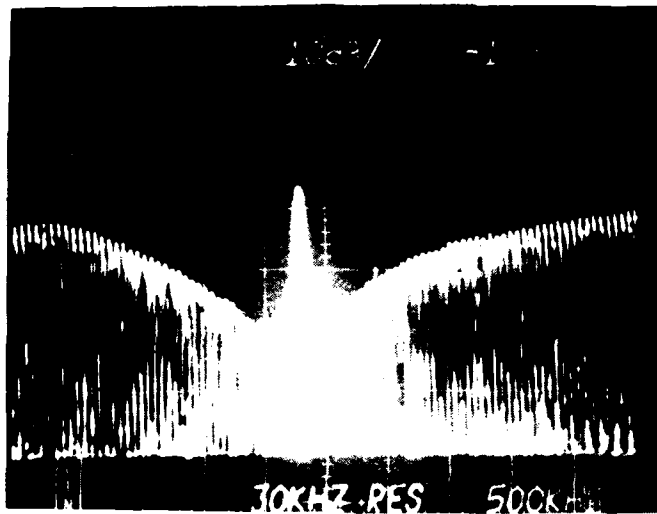

FIGURE 10
CANCELLATION NOTCH ANTENNA VSWR 3:1 PRIOR TO MATCHING AT 2.2 MHz
HIGH AND MEDIUM POWER CANCELLERS

The 26 dB additional padding makes up for the cancellation normally furnished by the high power canceller.

Figure 11A shows the uncanceled transmitter (+6 dBm) at 17 MHz and the uncanceled pilot -42 dBm at 12.2 MHz together with a swept probe (-50 dBm). Figure 11B shows the cancelled residue with both loops functioning. The transmit residue has fallen to -20 dBm and the pilot at -70 dBm. The probe signal in the vicinity of the pilot has dropped to -82 dBm. Transmitter noise in the vicinity of the pilot would decrease 32 dB.

Figures 12A and 12B are similar to Figures 13A and 13B except that the pilot signal is above the transmitted frequency and the spectrum analyzer scales differ. The probe signal dropped from -56 dB to -88 dB in the vicinity of the pilot. Figures 12B and 13B show that noise cancellation between the transmit signal and the pilot is relatively good even though the pilot was removed from the transmit frequency by -29% and 17% for these tests. It appears that the pilot-directed technique should have merit for use with a multicoupler and several receivers tuned between the transmitter and pilot.

3.3.1 Noise Canceller - Problem Areas

Cancellation systems have, of necessity, to be designed to meet a specific interference threat. The noise canceller is no exception. The intent in this design was to cancel the pilot residue remaining after the high power canceller to below -63 dBm. The uncanceled pilot at the receive port would be as high as -23 dBm when the pilot is relatively close to the transmitted signal. It is evident that there is sufficient loop gain to achieve over 40 dB of pilot cancellation since the cancelled pilot residue is well below -63 dBm.

The required reference level for the noise canceller is difficult to analyzer. It is essential that there be sufficient pilot reference signal to cancel the pilot signal remaining after both the high and medium power loops cancel the transmit signal. It is equally important that the pilot-directed loop does not add sufficient transmit signal so as to unlock the medium power weight nor to distort the transmit signal sufficiently to limit cancellation.

Several factors led to a misappraisal of the weighted reference level required from the pilot-direct loop. In the original design plan, the high, medium, and pilot-directed loop were all to operate in parallel. It proved necessary to operate the high power loop in series with the medium and noise power loop. If this change had not been made, the error signal for the high power loop would be nulled by the fast medium power loop and the slower high power control circuit would stop driving the goniometers short of their optimum null. This change increased the reference power required from the pilot-direct loop by 7 dB above that required in the original configuration.

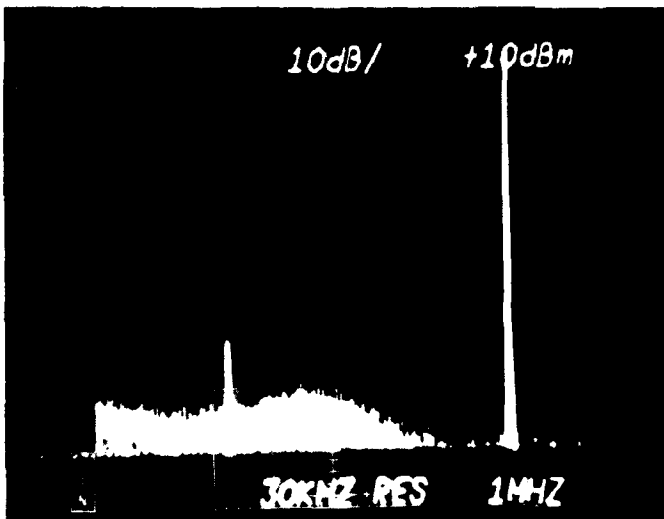

Transmit +55 dBm at 17 MHz
 Pilot 0 dBm at 12.2 MHz
 Antenna Isolation 41 dB
 High Power Loop Open
 Uncanceled Residue

FIGURE 11A

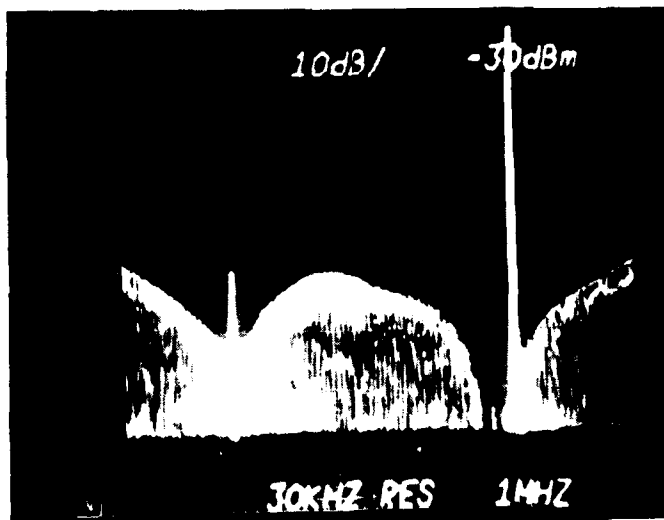

Transmit +55 dBm at 17 MHz
 Pilot 0 dBm at 12.2 MHz
 Antenna Isolation 41 dB
 High Power Loop Open
 (Transmit Residue -20 dBm)
 Cancelled Residue

FIGURE 11B

FIGURE 11
 CANCELLATION NOTCH - HIGH AND MEDIUM POWER CANCELLERS

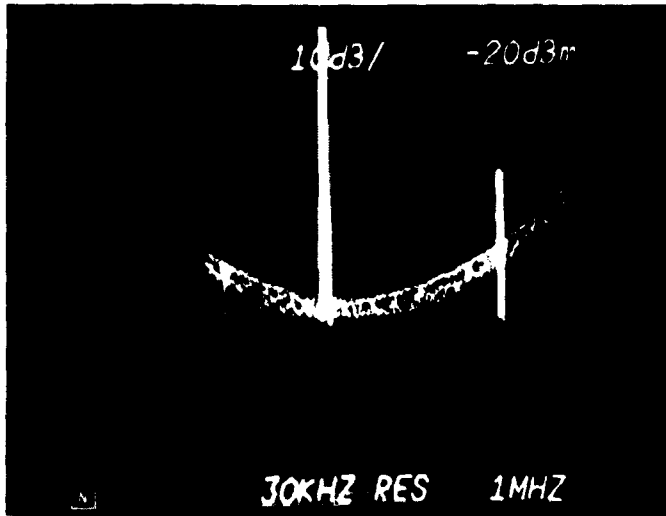

Transmit +55 dBm at 17 MHz
 Pilot 0 dBm at 19.9 MHz
 Antenna Isolation 41 dB
 High Power Loop Open
 Uncancelled Residue

FIGURE 12A

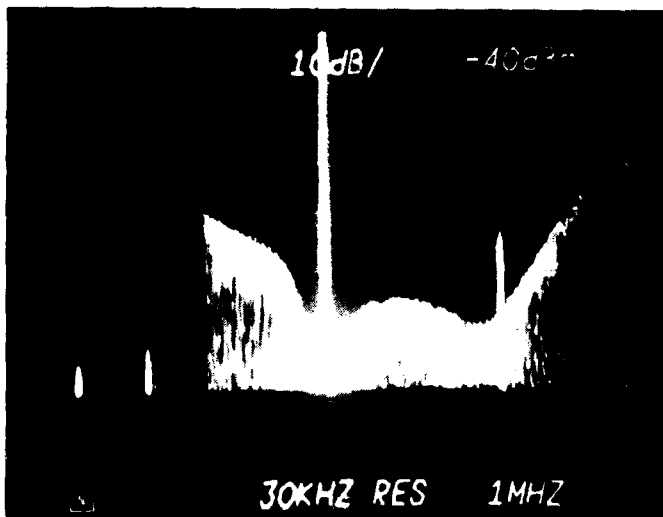

Transmit +55 dBm at 12 MHz
 Pilot 0 dBm at 19.9 MHz
 Antenna Isolation 41 dB
 High Power Loop Open
 Cancelled Residue

FIGURE 12B

FIGURE 12
 PILOT-DIRECTED NOISE CANCELLER PERFORMANCE - PILOT ABOVE TRANSMIT
 FREQUENCY

Had time permitted, additional gain might have been added to the pilot-directed loop. As it was, tests proceeded by substituting attenuation for the high power canceller. Previously, the medium power canceller and pilot-directed loop operated satisfactorily together. A problem developed which limited the operating range. Time did not permit a resolution of that problem.

SECTION IV

CONCLUSIONS AND RECOMMENDATIONS

The high and medium power loops meet all the static requirements for the system. Simulation of antenna coupling variation at high power requires the construction of special test equipment. The test equipment has not been built. Performance under dynamic conditions has not been verified, although tests on the servo loop using a potentiometer in place of the goniometer indicate that the response should be adequate.

Dynamic tests should be run to determine the maximum rate at which the RF phase can change without degrading cancellation.

The medium power weights are over-designed. A significant saving in size, weight, and power by utilizing weights with a lower third-order intercept can be achieved. The design goal can be achieved with a third-order intercept for the weights of +38.5 dBm. The weights used have an I_3 of +54 dBm. Thirty-two diodes and 120 watts of dc power are required to achieve this intercept. The particular weights were used for expediency. They were available from the HFICS program. The medium power weights can be redesigned to be far less costly. An I_3 of +44 dBm should be adequate. The change would permit cutting the diode content in half and the power supply requirement to about a quarter.

The pilot-directed noise canceller loop deserves further effort. If the problem areas can be resolved, it should prove very useful for long haul circuits.



MISSION
of
Rome Air Development Center

RADC plans and executes research, development, test and selected acquisition programs in support of Command, Control Communications and Intelligence (C³I) activities. Technical and engineering support within areas of technical competence is provided to ESD Program Offices (POs) and other ESD elements. The principal technical mission areas are communications, electromagnetic guidance and control, surveillance of ground and aerospace objects, intelligence data collection and handling, information system technology, ionospheric propagation, solid state sciences, microwave physics and electronic reliability, maintainability and compatibility.

