

AD-A084 079

FOREIGN TECHNOLOGY DIV WRIGHT-PATTERSON AFB OH
SYSTEM OF REMOTE-CONTROL DEVICES FOR AUTOMATED CONTROL SYSTEMS --ETC(U)
APR 80 G V ANTONOV, L K BIGLOV, E S LIQUM
FTD-ID(RS)T-0561-80

F/G 5/1

UNCLASSIFIED

NL

1-1
1-1



END
DATE
FILMED
6-80
DTIC

2

FTD-ID(RS)T-0561-80

ADA084079

FOREIGN TECHNOLOGY DIVISION



SYSTEM OF REMOTE-CONTROL DEVICES FOR AUTOMATED
CONTROL SYSTEMS OF INDUSTRIAL ENTERPRISES

By

G. V. Antonov, L. K. Biglov, E. S. Ligung



S DTIC
ELECTE **D**
MAY 13 1980
D

FILE COPY



Approved for public release;
distribution unlimited.

80 5 12 190

Accession For	
NTIS GRA&I	<input checked="" type="checkbox"/>
DDC TAB	<input type="checkbox"/>
Unannounced	<input type="checkbox"/>
Justification	<input type="checkbox"/>
By _____	
Distribution/	
Availability Codes	
Dist.	Avail and/or special
A	

FTD -ID(RS)T-0561-80

EDITED TRANSLATION

(14) FTD-ID(RS)T-0561-80 (17) 21 Apr 1980 (12) 11

MICROFICHE NR: FTD-80-C-000478

(6) SYSTEM OF REMOTE-CONTROL DEVICES FOR AUTOMATED CONTROL SYSTEMS OF INDUSTRIAL ENTERPRISES.

By: (10) G. V. Antonov, L. K. Biglov, E. S. Ligum

English pages: 8

(21) Edited trans. of Source: Pribory i Sistemy Upravleniya

Country: (USSR) 111 p7-9 Nov 72, by Translated: Martin J. Folan.

Requester: FTD/SDSY

Approved for public release; distribution unlimited.

<p>THIS TRANSLATION IS A RENDITION OF THE ORIGINAL FOREIGN TEXT WITHOUT ANY ANALYTICAL OR EDITORIAL COMMENT. STATEMENTS OR THEORIES ADVOCATED OR IMPLIED ARE THOSE OF THE SOURCE AND DO NOT NECESSARILY REFLECT THE POSITION OR OPINION OF THE FOREIGN TECHNOLOGY DIVISION.</p>	<p>PREPARED BY: TRANSLATION DIVISION FOREIGN TECHNOLOGY DIVISION WP-AFB, OHIO.</p>
---	--

FTD -ID(RS)T-0561-80

Date 21 Apr 19 80

142600

JOG

U. S. BOARD ON GEOGRAPHIC NAMES TRANSLITERATION SYSTEM

Block	Italic	Transliteration	Block	Italic	Transliteration
А а	<i>А а</i>	A, a	Р р	<i>Р р</i>	R, r
Б б	<i>Б б</i>	B, b	С с	<i>С с</i>	S, s
В в	<i>В в</i>	V, v	Т т	<i>Т т</i>	T, t
Г г	<i>Г г</i>	G, g	У у	<i>У у</i>	U, u
Д д	<i>Д д</i>	D, d	Ф ф	<i>Ф ф</i>	F, f
Е е	<i>Е е</i>	Ye, ye; E, e*	Х х	<i>Х х</i>	Kh, kh
Ж ж	<i>Ж ж</i>	Zh, zh	Ц ц	<i>Ц ц</i>	Ts, ts
Э э	<i>Э э</i>	Z, z	Ч ч	<i>Ч ч</i>	Ch, ch
И и	<i>И и</i>	I, i	Ш ш	<i>Ш ш</i>	Sh, sh
Й й	<i>Й й</i>	Y, y	Щ щ	<i>Щ щ</i>	Shch, s ^h ch
К к	<i>К к</i>	K, k	Ъ ъ	<i>Ъ ъ</i>	"
Л л	<i>Л л</i>	L, l	Ы ы	<i>Ы ы</i>	Y, y
М м	<i>М м</i>	M, m	Ь ь	<i>Ь ь</i>	'
Н н	<i>Н н</i>	N, n	Э э	<i>Э э</i>	E, e
О о	<i>О о</i>	O, o	Ю ю	<i>Ю ю</i>	Yu, yu
П п	<i>П п</i>	P, p	Я я	<i>Я я</i>	Ya, ya

*ye initially, after vowels, and after ь, ь; e elsewhere.
When written as ë in Russian, transliterate as yë or ë.

RUSSIAN AND ENGLISH TRIGONOMETRIC FUNCTIONS

Russian	English	Russian	English	Russian	English
sin	sin	sh	sinh	arc sh	sin ⁻¹
cos	cos	ch	cosh	arc ch	cos ⁻¹
tg	tan	th	tanh	arc th	tan ⁻¹
ctg	cot	cth	coth	arc cth	cot ⁻¹
sec	sec	sch	sech	arc sch	sec ⁻¹
cosec	csc	csch	csch	arc csch	csc ⁻¹

Russian English

rot curl
lg log

SYSTEM OF REMOTE-CONTROL DEVICES FOR AUTOMATED CONTROL SYSTEMS OF
INDUSTRIAL ENTERPRISES

Engineers G. V. Antonov, L. K. Biglov, E. S. Ligum

In automated systems of production control (ASUP) and of technological processes control (ASUTP), the most important part is made up by devices for communications with computers (VM) with objects of automated production.

Since in a number of cases the introduction of ASUP or ASUTP is accomplished on the basis of existing system dispatching of production, remote-control means can be used for communications of the VM with objects.

Below, we present the basic technical characteristics and briefly examine the principles of action of the developed SKB plant of remote-control equipment of the system of remote-control devices TM-301 for the ASU's of industrial enterprises. This development was accomplished on the basis of the TM-300 device which is put out in series by the plant.

The TM-301 system is designed for operation along separate two-lead communications lines between the equipment of the control point (PU) and any of the controlled points (KP) of a number up to 25.

Each KP TM-301 can accept: up to 50 commands of remote-control (TU) with two-position objects; codes for setting assignments to the teleregulator (TR) [up to 30]; up to 30 four-digit decimal numbers of the designated digital boards (TsS), led to the display board of operators' panels; up to 40 service commands (SK), also led to the board of panels.

From each KP, we can transmit to the PU: up to 60 telesignals (TS) of the state of the two-position objects; up to 60 telemeasurements of current (TIT) and up to 60 telemeasurements of integral (TII) values of parameters; statistical information (SI) in the form of decimal numbers, selected in any amount (from 1 to 15) of panels of manual input PRV with a total number of digits for one PRV not greater than 120.

The PU equipment accomplished control of the receiving-transmitting of all types of information, processing and distribution of accepted information in a form which is convenient for the dispatcher, and also exchange with all types of information from the VM.

For the best satisfaction of the requirements of each requester, the TM-301 system was developed in the form of an assembly of independent, mutually-connected functional devices.

Functional devices of equipment PU and KP are presented in Figs. 1 and 2, respectively. This figures show, with the thin lines, the buses for exchange with service signals, and with the thick lines - buses for transmission of information, and with dotted lines - the address buses.

The transceivers of the APP-PU and the APP-KP ensure exchange between the PU and the KP of ally types of information at a distance of up to 15 km with the use of separated pairs in telephone cable as the communications lines. Service, address and informational signals are transmitted along the communications lines in the form of pulses of DC with a specific duration, in which regard the noise stability of their reception is ensured by amplitude-time selection. Separation in time with reception of linear signals is achieved by the device in the APP-PU and APP-KP of pulse distributors, from which the distributor of the APP-PU is the leader.

Synchronization of the work of the distributors according to cycles is ensured by simultaneous transmission from the PU to all KP's of a pulse of increased duration, and synchronization of work of the distributors by tacts (within the cycle) - by the use of highly-stable automonous tact-pulse generators.

Found in the basis of construction of the equipment is a principle of division in time of transmission of individual types of information with sporadic transmission of the TS [1]. For achieving high noise-resistance of transmission of coded series, a repetition method is used along communications lines. We envision continuous automatic monitoring of accuracy of communications lines and linear-address units [2], and also of the basic units of PU and KP equipment.

Transmission of TS is done automatically from all KP's or from a selected KP with a change in the state of any sensor of TS ATC and by request from the PU, which also permits monitoring the accuracy of the reception-transmission tract of TS.

Information from TS can be recorded on a blank of the electro-controlled reading machine ЭУМ or on punched tape.

When it is necessary to transmit the TS on the down time of an aggregate, we use a device for signalization of down time of the USP, which permits regulating the setting of down time in a range from 0.5 to 10 min, with stages of 30 sec. Assignment of TU commands by the dispatcher is accomplished according to the method proposed in work [3].

The device ensures cyclical inquiry of sensors of the TIT ATIT of all KP's with a speed of 20 sensors per second. With the appearance of an inquiry for transmission from a selected KP of another type of information, the receiver of current telemeasurements ПРТТ accomplishes automatic transition to inquiry ATIT of other KP's.

The transmitter of current telemeasurements ПАТТ is calculated for transmission of TIT from the sensors with a current output signal of 0-5 mA and a frequency output signal of 4-8 kHz. For transmission of TIT, we use coding of signals in the communications channels with two pulses - marks, the distance in time between the fronts of which is proportional to the output signals of the sensors [4].

The reliability of reception of TIT is achieved by calculation of the number of marks per fixed time interval, and also by comparing the address of the group of TIT parameters requested from the PU with the accepted address. The device ensures automatic indication of a breakdown in normal operation of the TIT tract and the possibility of excluding the damaged KP from the inquiry cycle.

The receiver of current telemeasurements converts signals of telemeasurement to nine-digit binary code, designed for input to the VM or the information processing and reproducing device. For reproduction of TIT on analog instruments, we use a 30-channel digital-analog transformer (TsAP), in each of the channels of which the code of the TIT parameter is converted to DC 0-5 mA on a load of 0-2.5 k Ω . Reproduction of TIT on three-digit digital indicators in absolute or relative values of measured values is accomplished by the device for digital indication УЦМ. Here, the number of digital indicators is not limited.

Switching of an analog or digital indicator to the device is done with a button or key. With a large number of TIT parameters, we use a device for selection of current telemeasurements YBT. The selection of the needed measurement is done with a ten-key switch which is positioned on the ПБТ current telemeasurements-selection panel and is monitored visually by four-digit digital indicators. The address of selected parameters of TIT is stored in the UVT memory before cancellation of indication by the dispatcher (capacity of the memory YBT is six addresses).

The basic error of the TIT transmission tract with digital reproduction or input to the VM is 1%, and with analog reproduction 1.5%.

For relief of the dispatcher, we envision an individual light or overall sound signalization of output of telemeasured parameters after the limits of upper and lower settings assigned for them (with an accuracy of 1%) and a single recording on a ЭУМ blank or punched tape of time, address and value of setting of TIT, the value of which went beyond the limits. Simultaneously, the device for signaling deviations of YCO parameters affords the possibility to automatically monitor the accuracy of the TIT tract by transmitting the test telemeasurement from each KP.

For a telemeasurement of integrated values, we use sensors with pulse-count output with a current of no less than 5 mA at resistance 2 k Ω or contact sensors with a frequency of the output pulses of no more than 5 Hz. For considering idle time of the equipment, the YCP forms on the KP half-minute pulses with an accuracy no worse than 0.5%;

these pulses, through the downtime relay contacts, proceed to the inputs of the integrators of integrated-measurements transmitters ПДИТ. The capacity of each integrator is 64,000 pulses. The TII's are transmitted in nine-digit binary code, in which regard with inquiry of the integrators, the information stored in them disappears.

A TII call is done automatically - by the time formation device УФВ - sequentially from all KP's or manually by the dispatcher from all or from the selected KP.

The accepted TII information is recorded on a ЭУМ blank and punched tape or is indicated on overall or individual digital indicators in absolute or relative units. The ПРПИ periodic information receiver ensures, also, retranslation of the TII according to the assigned program to the integrators of the equipment of the higher PU.

Call and reproduction of the SI is done similar to TII. We additionally envision an inquiry for call of SI on the initiative of the KP with the aid of inquiry buttons placed on the ПРВ.

Address and value of setting are assigned to the teleregulators by the dispatcher with an accuracy of 0.25% by means of a switching key and are monitored by digital indicators. We can connect to the KP regulators with a code (eight binary digits) input, controlled by the receiver of coded commands ПРКК, with the input in the form of a frequency signal (4-8 or 2-4 kHz), signal of AC (0-2 or 1-0-1 V) or pneumatic signal (0.2-1 atm), controlled by the receiver of tele-regulation ПРТР through individual remote-control automatic setters of a corresponding modification, and also regulators with an input on DC 0-5 mA, controlled by the TsAP.

Transmission of TsS and SK is accomplished by the dispatcher similarly to transmission of TR. The accepted TsS and SK are stored until their clearing by the operator or by a special command from the PU. Transmission of counsels is possible on the initiative of the KP (up to 10 inquiries of counsels).

The reading device УП is designed for switching up to four ЭУМ's, on which, according to the assigned program-synchronizing device УПС, according to the rigid program we accomplish digital-letter recording of TII, SI, TS, address and values of settings of parameters TIT, which have gone beyond the limits of the assigned settings. Also done

is perforation on tape of the same parameters by a PL-80 type perforator in a code according to GOST 10859-64. We envision the possibility of perforation of tape from a keyboard of one of the ЭУМ's.

Included in the make-up of the TM-301 system is a conjugation device with a 2V-rank computer, which ensures transmission from the VM of information TU, TR, TsS and SK, and also input into the VM according to commands acquired from it of information TS, TII, SI and TIT. With consideration of the character of the accepted PU information and for excluding losses of information, we envision input into the computer of TS, TII and SI on the initiative of the TM-301. The development of the conjugation device was accomplished by the TsNIIKA and SKB NZTA jointly [State All-Union Central Scientific Research Institute of Complex Automation and the Special Design Office of the Nal'chik Telemechanical Equipment Plant].

Much attention in the development of a scheme and construction of the equipment was devoted to questions of convenience of its use, effective monitoring of accuracy of individual units and functional devices. The use of the most complex part of the system - the PU equipment - is considerably facilitated thanks to the use of the PU service panel.

The units for interlocking introduced into the PU devices and for signalization will permit the use of one system of equipment for operation with three dispatcher points and the VM simultaneously.

The equipment is made on the element-construction base of the "Spektr" system; the devices are placed in cases of normal or dust-resistant purpose.

The test sample of the TM-301 device passes industrial tests in the composition of the ASUTP of the nodulizing plant of the Sokolov-Sarbayskiy Mining-Enriching Combine.

BIBLIOGRAPHY

1. Портнов М. Л., Пшеничников А. М. Телемеханическая система обмена информацией между вычислительной машиной и технологическими объектами промышленных предприятий. «Автоматика и телемеханика», 1968, № 4.
2. Пшеничников А. М., Портнов М. Л., Афанасьев Л. К. Авторское свидетельство № 208797. «Бюллетень изобретений», 1968, № 4.
3. Портнов М. Л., Варкентин С. Н. Авторское свидетельство № 278473. «Бюллетень изобретений», 1970, № 25.
4. Хволес В. А., Пшеничников А. М. и др. Авторское свидетельство № 277587. «Бюллетень изобретений», 1972, № 2.

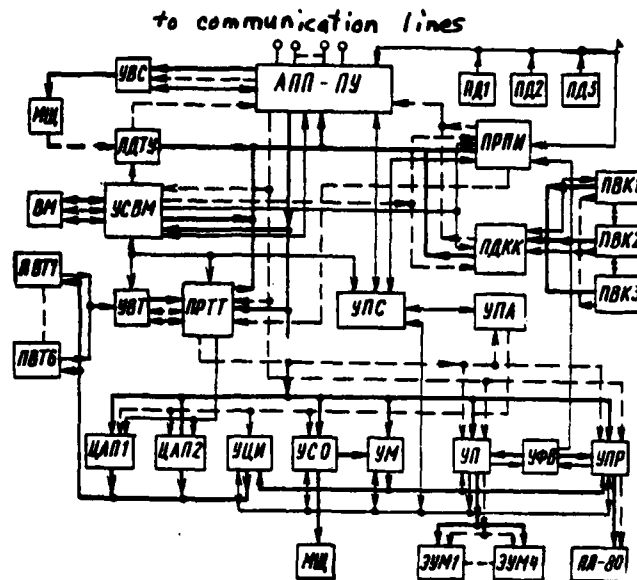

Figure 1. Structural diagram of the PU equipment:
 ПМЦ - mimic panel; ПД1 - ПД3 - dispatcher panels; ВМ - computer;
 АПП-ПУ - equipment of receiving-transmitting point of control; УВС - device for reproduction of signalization; ПДТУ - telecontrol command transmitter; ПРПИ - receiver of periodic informatio of telemeasurements of integrated values of parameters and statistical information (TII and SI); ПВК1-ПВК3 - panels for input of coded commands; ПДКК - transmitter of coded commands (TR, TsS, SK); ПРТТ - receiver of current telemeasurements; ПВТ1-ПВТ6 - panels for selection of current telemeasurements; УВТ - device for selection of current telemeasurements; ЦАП1, ЦАП2 - digital-analog converters; УСО - device for signalization of deviations of TIT parameters from assigned settings; УПА - program-address device; УФВ - time formation device; УП - reading device; ЗУИ1-ЗУИ4 - electrocontrol reading devices; УПР - perforation device; ПЛ-80 - tape puncher; УЦИ - digital indication device; УПС - program-synchronizing device; УСВМ - device for conjugation with the computer; УМ - scaling device.

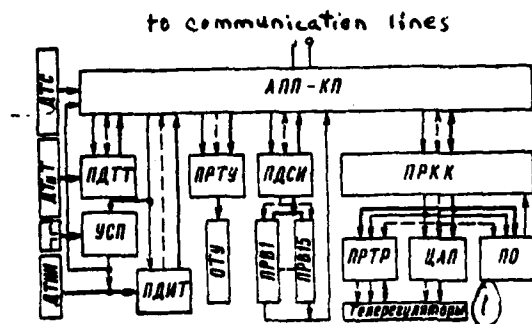

Figure 2. Structural schematic of KP equipment:
 АПП-КП - equipment of the receiving-transmitting KP with a telesignal (TS) transmitter; ПДТТ - transmitter of current telemasurements; ПДИТ - transmitter of integrated telemasurements; ПРТУ - receiver of remote control commands; ПДСИ - transmitter of statistical information; ПРКК - receiver of coded commands; ПРТР - remote control receiver; УСП - idle-time signalization device; ПО - operator panel; ПРВ1-ПРВ15 - manual input panels; ОТУ - object of remote control; ДТИИ - TII sensor; ДТИТ - TIT sensor; ДТС - TS sensor.

Key: 1 - teleregulators.