

AD-A084 095

ARMY ENGINEER WATERWAYS EXPERIMENT STATION VICKSBURG--ETC F/G 13/13
ULTRASONIC VELOCITY MEASUREMENTS IN CONCRETE, LOCK AND DAM NUMB--ETC(U)
APR 80 H T THORNTON, D GLASS
WES/MP/SL-80-2

NL

UNCLASSIFIED

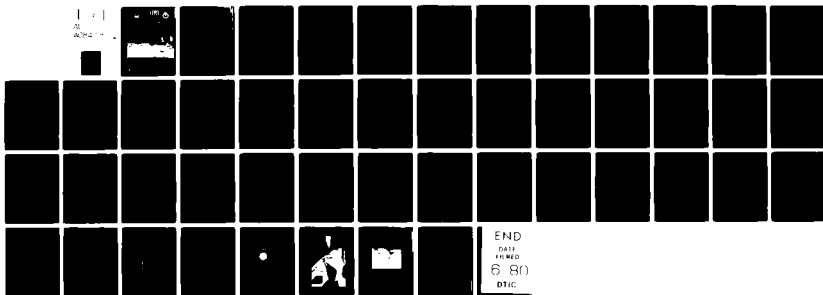

ADA 084095

ULTRASONIC VELOCITY MEASUREMENTS IN
CONCRETE, LOCK AND DAM NO. 24
MISSISSIPPI RIVER

by

Henry T. Thornton, Jr., Dale Glass

Structures Laboratory

U. S. Army Engineer Waterways Experiment Station
P. O. Box 631, Vicksburg, Miss. 39180

April 1980
Final Report

Approved For Public Release; Distribution Unlimited

DTIC
ELECTE
MAY 1 2 1980
S D

FILE COPY

Report for U. S. Army Engineer District, St. Louis
St. Louis, Missouri 63101

80 5 8 019

**Destroy this report when no longer needed. Do not return
it to the originator.**

**The findings in this report are not to be construed as an official
Department of the Army position unless so designated
by other authorized documents.**

Unclassified

SECURITY CLASSIFICATION OF THIS PAGE (When Data Entered)

REPORT DOCUMENTATION PAGE		READ INSTRUCTIONS BEFORE COMPLETING FORM
1. REPORT NUMBER Miscellaneous Paper SL-89-2	2. GOVT ACCESSION NO. AD-A084 025	3. RECIPIENT'S CATALOG NUMBER
4. TITLE (and Subtitle) ULTRASONIC VELOCITY MEASUREMENTS IN CONCRETE, LOCK AND DAM NO. 24, MISSISSIPPI RIVER.	5. TYPE OF REPORT & PERIOD COVERED Final report	
6. AUTHOR(s) Henry T. Thornton, Jr. Dale Glass	7. PERFORMING ORG. REPORT NUMBER	
8. PERFORMING ORGANIZATION NAME AND ADDRESS U.S. Army Engineer Waterways Experiment Station Structures Laboratory P. O. Box 631, Vicksburg, MS 39180	9. CONTRACT OR GRANT NUMBER(s)	
11. CONTROLLING OFFICE NAME AND ADDRESS U.S. Army Engineer District, St. Louis St. Louis, Missouri 63101	10. PROGRAM ELEMENT, PROJECT, TASK AREA & WORK UNIT NUMBERS	12. REPORT DATE Apr. 1980
14. MONITORING AGENCY NAME & ADDRESS (if different from Controlling Office) 1248	13. NUMBER OF PAGES 43	15. SECURITY CLASS. (of this report) Unclassified
16. DISTRIBUTION STATEMENT (of this Report) Approved for public release; distribution unlimited.		
17. DISTRIBUTION STATEMENT (of the abstract entered in Block 20, if different from Report)		
18. SUPPLEMENTARY NOTES		
19. KEY WORDS (Continue on reverse side if necessary and identify by block number) Alkali aggregate reactions Lock and Dam No. 24, Mississippi River Concrete cracking Nondestructive tests Deterioration Performance Freeze-thaw Structural behavior Ultrasonic velocity		
20. ABSTRACT (Continue on reverse side if necessary and identify by block number) - Ultrasonic velocity measurements were made through concrete piers No. 2 through 15, which constitute part of the dam structure. Velocity measurements were also made through selected concrete columns that support the service bridge. Areas characterized by low velocities are delineated. The velocity data indicate that a condition of cracking and deterioration exists in the concrete around and near the trunnion, head plates, and connections of the embedded anchorage beams in piers No. 2 through 15. In some piers the (Continued)		

6
Number

10

11

1248

DD FORM 1 JAN 73 1473

EDITION OF 1 NOV 65 IS OBSOLETE

Unclassified

SECURITY CLASSIFICATION OF THIS PAGE (When Data Entered)

422 425

JP

Unclassified

SECURITY CLASSIFICATION OF THIS PAGE(When Data Entered)

20. ABSTRACT (Continued)

condition may extend down the top anchorage beam as far as 15 ft from the trunnion and down the lower beam as far as 6 ft from the trunnion. The columns that were tested have also been damaged by cracking. The cracking on the piers and columns has probably progressed over the years and was probably caused by dynamic and static stress concentrations due to gate vibration and structural movement, aided by freezing-and-thawing action, and possibly, alkali-aggregate reaction. It is recommended that steps be taken to eliminate inordinate vibration of the gates due to hydraulic action, that pooling of water on the structure be prevented, and that appropriate methods be employed for exploratory work to determine the type and extent of repairs needed to assure the desired long-range performance of the structure.

Unclassified

SECURITY CLASSIFICATION OF THIS PAGE(When Data Entered)

PREFACE

This investigation was requested by Mr. Lee Lenzner of the St. Louis District in a telephone conversation with Mr. Henry T. Thornton, Jr., of the Structures Laboratory (SL), U. S. Army Engineer Waterways Experiment Station (WES), on 11 May 1979. The investigation was accomplished as a continuation of work requested and funded by DA Form 2544, work order No. ED 77-78, dated 9 August 1977, from the U. S. Army Engineer District, St. Louis. The work was performed by members of the staff of the SL under the direction of Mr. Bryant Mather, Chief, SL; Mrs. Katharine Mather, Chief, Engineering Sciences Division (ESD); and Mr. B. R. Sullivan, Chief, Engineering Physics Branch (EPB). The tests were performed during the period of 10 through 14 September 1979 by Messrs. Dale Glass, Dan Wilson, and M. K. Lloyd of SL, WES. Mr. Henry T. Thornton, Jr., of SL provided technical assistance on 12 September. Mr. Glass was project leader and coauthored this report with Mr. Thornton.

The Commander and Director of the WES during the conduct of this investigation and publication of this report was COL Nelson P. Conover, CE. Technical Director was Mr. Fred R. Brown.

Accession For	
NTIS GMMI	<input checked="" type="checkbox"/>
DOC TAB	
Unannounced Justification	
By _____	
Distribution/	
Availability Codes	
Dist	Avail and/or special
A	

CONTENTS

	<u>Page</u>
PREFACE	1
CONVERSION FACTORS, INCH-POUND TO METRIC (SI)	
UNITS OF MEASUREMENT	3
PART I: BACKGROUND	4
PART II: CURRENT INVESTIGATION AND RESULTS	6
Objectives	6
Tests and Results	6
PART III: DISCUSSION OF RESULTS	9
PART IV: CONCLUSIONS AND RECOMMENDATIONS	12
TABLES 1-3	
FIGURES 1-23	
PHOTOS 1 and 2	

CONVERSION FACTORS, INCH-POUND TO METRIC (SI)
UNITS OF MEASUREMENT

Inch-pound units of measurement used in this report can be converted to metric (SI) units as follows:

<u>Multiply</u>	<u>By</u>	<u>To Obtain</u>
inches	2.54	centimetres
feet	0.3048	metres
feet per second	0.3048	metres per second
pounds (force)	4.448222	newtons

ULTRASONIC VELOCITY MEASUREMENTS IN CONCRETE,
LOCK AND DAM NO. 24, MISSISSIPPI RIVER

PART I: BACKGROUND

1. During 1973, velocity measurements were made through portions of selected piers at Lock and Dam No. 24 and 25. The results of these tests were reported to the St. Louis District by letter dated 29 October 1973, subject, "Results of Soniscope Survey of Lock and Dam No. 24 and 25, Mississippi River." In 1976,* the presence of alkali-silica reaction in concrete from an intermediate wall of this structure was established by the examination of 6-in.-** and 4-in.-diameter cores. The concrete cores were from an area of undeteriorated concrete. In October 1978, five NX concrete cores were received from the U. S. Army Engineer District, St. Louis, for examination. These cores were taken from the downstream portions of three piers in the dam of Lock and Dam No. 24. The cores were in fragments with the longest intact piece of core being about 2-1/2 in. Some of the reported† results of the examination of these cores were:

- a. Examination of the concrete fragments showed that the paste was usually coated with white to translucent alkali-silica gel, showing typical drying shrinkage cracks. The gel was most obvious on old fracture surfaces and around coarse aggregate particles.
- b. White exudations found on the few formed surfaces available for study consisted largely of calcite. Some alkali-silica gel was probably present but was effectively masked by the calcite. The composition of the surface exudation indicates that it was produced by leaching calcium hydroxide from the concrete along cracks and its subsequent

* U.S. Army Engineer Waterways Experiment Station Petrographic Report, dated 23 January 1976, subject, "Tests and Examination of Concrete Cores from Lock and Dam 24 and Lock and Dam 25," Vicksburg, Miss.

** A table for converting inch-pound units of measurement to metric (SI) units of measurement is found on page 3.

† U.S. Army Engineer Waterways Experiment Station Petrographic Report, dated 4 December 1978, subject, "Project Examination of Fragmented Concrete Cores from Lock and Dam 24, U. S. Army Engineer District, St. Louis," Vicksburg, Miss.

conversion to calcium carbonate (calcite) by reaction with carbon dioxide in the atmosphere.

- c. Examination of sawed and ground concrete surfaces verified that the concrete was not air-entrained. Fractures generally went around rather than through aggregate particles.

In addition, the following statements were contained in the petrographic report:*

"Alkali-silica reaction has occurred in this concrete. The smaller core diameter tended to make the concrete appear more deteriorated than if larger diameter core had been taken. In addition, it is believed that freezing-and-thawing damage and probably some structural cracking were also present in this approximately 40-year-old concrete. As a result of these possibilities, it is uncertain how much effect the alkali-silica reaction has had on the condition of the concrete in the piers of this structure."

* Op. cit., U. S. Army Engineer Waterways Experiment Station Petrographic Report, dated 4 December 1978.

PART II: CURRENT INVESTIGATION AND RESULTS

Objectives

2. The primary purpose of this investigation was to determine the extent and severity of cracking near the trunnions on the downstream portions of 14 concrete piers (No. 2 through 15) where deterioration has been in progress for a number of years. The deterioration is manifest as random cracking filled with exudation product. Since this condition also exists on the concrete columns that support the service bridge as well as on the piers (Photo 1), a secondary objective was to test selected columns in an attempt to determine the effect of the cracking on the structural integrity of the columns.

Tests and Results

Piers

3. The test equipment used in this investigation is described in test Method CRD-C 51-72* (ASTM Designation C 597-71). Velocity measurements were made through piers No. 2 through 15 which constitute part of the dam structure. Access to both sides of a pier was gained by having the transducer holders move along the tainter gate arms located on each side of the pier. Also, a platform built by Lock and Dam No. 24 Government employees was lowered in place using the gantry crane in order to obtain access and make velocity measurements under the trunnion and near the waterline on each pier (Photo 2). The station numbers, elevations, path lengths, and velocities are given in Table 1. Figures 1 through 14 show the side elevations of each pier with the velocities obtained at each data point inscribed on the drawing. This was done in an attempt to delineate and compare areas characterized by low velocities (below 15,000 fps). Figure 15 outlines the area where anomalous velocities

* U. S. Army Engineer Waterways Experiment Station, CE. August 1949 (with quarterly supplements). Handbook for Concrete and Cement, Vicksburg, Miss.

were obtained. This area is bounded by the line of extreme cases, i.e., piers No. 4, 6, 9, and 13. The extremity of low or no velocity readings varies slightly with station number and elevation from pier to pier, but Figure 15 is generally representative of piers No. 2 through 15.

Columns

4. The cracking and exudation are also evident in the upper elevations of the concrete columns that support the service bridge (Photo 1). Most of the cracking has occurred just below the construction joint at elevation 471.0 and extends down the columns for 4 or 5 ft. More cracking was observed on the two downstream columns than on the two upstream columns on each pier. Velocity measurements were made through columns on selected piers in order to assess the effect of these cracks on velocity and, in turn, give some indication with regard to the condition of the columns. For identification purposes the columns on each pier were numbered 1 through 4 (plan view) beginning with the southwest (assuming downstream to be south) column and numbering in a clockwise direction; i.e., in each group of four, Column 1 is the downstream, right-side column, Column 2 is the upstream, right-side column. Table 2 gives the results of velocity measurements made through the upper elevations in Columns 1 and 4 on piers No. 2, 9, and 16. Figures 16, 17, and 18 show sketches of these columns with velocities inscribed near the data stations. Table 3 gives results of measurements made through lower elevations of all four columns on pier No. 16. Figures 19 and 20 are sketches of these columns with velocities inscribed at the data stations. Velocities obtained through the apparently undamaged concrete in the columns indicate the datum velocity to be about 15,000 fps. All velocities in Table 2 except one fall below 15,000 fps. This might be expected since these velocities were obtained in areas where cracking and exudation are most prevalent. One may expect, however, to see an increase in velocity as measurements are made at lower elevations, assuming that concrete of better quality would be encountered. Figures 17 and 18 show a general trend in this direction, but the concrete is still indicated to be of generally poor quality down to elevation 464.0. As indicated in Table 3 and Figures 19 and 20, velocity measurements were

made through the lower elevations of the columns on pier No. 16. These measurements produced velocities in the 14,000- to 15,000-fps range, but there were also numerous velocities obtained in the range of 9,000 to 12,000 fps. These low velocities indicate the presence of cracks, some of which were visible, in the lower elevations of these columns.

PART III: DISCUSSION OF RESULTS

5. Figure 21 is a typical side elevation of piers No. 2 through 15, and shows the location of the embedded tainter gate tension anchorage. Figure 22 shows in more detail the upper portion of the anchorage and locates the velocity data points with respect to the anchorage beams. Data points 1 through 17 are of the current investigation. Data points A through D are of the 1973 investigation (mentioned in paragraph 3) that are thought to be pertinent here. Physical access to the downstream portions of the piers in the areas from which data were desired was restricted by the gate arms and the water level (Photos 1 and 2). The gates in each bay were manipulated to the allowable extent in order to maximize coverage of the extreme downstream area. In 1973 the gates were manipulated to expose maximum area between stations 79B and 90B at elevations 447 to 452. Although most of the data points used in the 1973 investigations were upstream from the data points used in the current study, four of them are pertinent to this study. Point A (1973) corresponds to point 4 (current); and points B, C, D (1973), although they do not correspond to current data points, have signal transmission paths that would pass through or near the steel anchorage beams. These four points, A, B, C, and D, are the only points of the 19 points used in 1973 that show decreased velocity; point B on pier No. 5 showed a decreased velocity; point C on piers No. 5 and 7 showed decreased velocities, and on pier No. 12 no signal passed through; at point D on pier No. 12 no signal would pass through. These data points located at or near elevations where the signal transmission path passed through or near the steel anchorage beam indicated the presence of some form of distress in 1973. The velocity data obtained in this current investigation tell the same story. There is some form of distress at or near the anchorage beams in the areas that were tested. A 12-in. steel beam normal to the transmission path in the center of a 10-ft section of concrete, if it were bonded, would not appreciably affect the ultrasonic velocity. Even an unbonded condition should not cause a drastic reduction in velocity. The data indicate that a general condition of cracking

and deterioration existed around and near the trunnion, head plates, and anchorage beam connections in each of the piers tested, and that some cracking has probably occurred around the top anchorage beam as far down as 15 ft from the trunnion and around the lower beam as far as 6 ft from the trunnion in some piers.

6. Figure 23 is a typical detail drawing of the trunnion, head plates, and anchorage beam connections. This drawing shows a 1/2-in.-thick plastic cork covering most of the head plates and extending down the anchorage beams for some distance. Also shown is a bituminous cement in the construction joint. The deterioration over the years of this cement or cork, or both, could provide a path for water to enter between the concrete and steel anchorage beams. The V-shaped depression at the junction of the concrete and trunnion head plate provides a reservoir where water could be stored for short durations. Stress concentrations at and near the trunnion and anchorage beam connections caused by vibrations of the gates could have provided the mechanism by which small cracks were formed and also could have added to the water intake. Periodic gate vibrations of a severe nature have been described by lock personnel and confirmed by members of the District office. Progressive cracking due to stresses from vibration, and the possible contribution of freezing and thawing of the water, and alkali-aggregate reaction could have resulted in the present condition of the piers. A similar combination of mechanisms probably caused the similar condition of the upper portion of the columns, i.e., cracks caused by stresses from vibration or structural movement and water entrance, with the floor slab at elevation 471.0 serving as a pooling area. Some of the larger cracks in the columns appear to have been caused by static stresses. Although it is beyond the intended scope of this investigation and report to address this issue, one or two observations will be offered here. The movement of a pier, of sufficient magnitude, could place any or all columns on that pier in a condition of inordinate static loading. It has been shown in the laboratory that the resistance to lateral movement (sliding) of a massive structure is greatly reduced while in a state of dynamic excitation, i.e., vibrating motion. The lateral force required to move a 3-

by 6- by 10-ft (high) block weighing over 28,000 lb was reduced from 10,000 lb to 250 lb when the concrete block was put in a state of vibrating motion. The implication here is that the vibration of the dam structure in the past could have caused, or contributed to, some movement of a pier or piers causing inordinate stresses in some of the columns, which resulted in the formation of the larger cracks in the columns.

PART IV: CONCLUSIONS AND RECOMMENDATIONS

7. Data input and information pertinent to this investigation were provided by the following sources:

1973 Velocity measurements
1976 Petrography tests
1978 Petrography tests
1979 Velocity measurements
Information from members of operating staff, Lock and Dam No. 24
Information from members of staff, St. Louis District Drawings and photographs, Lock and Dam No. 24

The evaluation of all data and information leads to the following conclusions:

- a. A condition of cracking and deterioration exists around and near the trunnion, head plates, and anchorage beam connections in piers No. 2 through 15. In some piers the condition may extend down the top beam as far as 15 ft from the trunnion and down the lower beam as far as 6 ft from the trunnion.
- b. The columns tested on piers No. 2, 9, and 16 have also been damaged by cracking and deterioration.
- c. The cracked and deteriorated condition of the piers probably started with the formation of small fractures in the concrete around the trunnions caused by dynamic or static stress concentrations, or both, resulting from gate vibration or structural movement, or both. The condition has apparently progressed over the years, possibly aided by alkali-aggregate reaction and freezing-and-thawing action.
- d. The cracking and deterioration in the upper portion of the columns (near elevation 471.0) has the same appearance as that of the piers. This is probably due to the entrance of water into the cracks from a pooling area, i.e., the floor slab at elevation 471.0. The cracking in the upper and lower portions of the columns could have been caused by either dynamic or static stresses, or both, although the cracks in the lower portions appear to have been caused by static stresses.

It is recommended that the following steps be taken as a minimum course of action in dealing with the problems:

- a. Eliminate or minimize inordinate vibration of the gates due to hydraulic action.
- b. Prevent the pooling of water on the piers near the trunnions and on the floor slabs at elevation 471.0.
- c. Select one pier, considering location and indicated condition, and employ appropriate methods for extensive exploratory work to determine the extent and severity of the cracking and deterioration so that appropriate methods, materials, and procedures for adequate repair may be selected in order to assure the desired long-range performance of the structure.

It is further recommended that the technology developed in the field by CE districts, and through research efforts by WES, pertinent to repair and rehabilitation of old or damaged concrete structures be considered in the planning of any extensive repair program.

8. In conclusion, if appreciable movement of any of the piers can be or has been confirmed by survey data, then evaluations of the stability and stress of the monoliths may be needed, taking into account the effect of the vibration of the gates.

Table 1
Velocity Measurements of Piers No. 2 Through 15*

Station	Elevation ft	Path Length ft	Velocity, ft/sec				
			Pier No. 2	Pier No. 3	Pier No. 4	Pier No. 5	Pier No. 6
88	452	10.0	16,000	15,875	15,625	16,000	15,875
88	450	10.0	16,000	15,875	15,385	16,000	15,875
90	452	10.0	16,000	15,625	8,265	16,000	15,875
90	450	10.0	15,875	14,085	12,195	15,875	16,000
90	446	10.0	15,875	B	B	B	B
92	452	10.0	16,000	15,750	NR	15,505	12,500
92	451	10.0	15,385	6,850	NR	10,990	NR
92	448	10.0	15,750	B	B	B	B
93	452	10.0	4,445	5,915	NR	11,430	NR
93	446	10.0	NR	15,625	NR	NR	NR
94	450	10.0	NR	NR	NR	NR	NR
94	444	10.0	16,000	14,925	NR	15,875	15,875
96	450	10.0	NR	NR	15,150	NR	NR
96	448	10.0	NR	NR	NR	NR	NR
96	446	10.0	NR	13,890	NR	14,925	NR
96	444	10.0	14,815	14,390	14,705	15,875	13,890
97	448	10.0	NR	NR	NR	NR	NR
97	444	10.0	NR	NR	NR	15,875	NR
98	444	10.0	NR	NR	NR	NR	NR

Station	Elevation ft	Path Length ft	Velocity, ft/sec				
			Pier No. 7	Pier No. 8	Pier No. 9	Pier No. 10	Pier No. 11
88	452	10.0	15,385	16,000	15,750	15,750	15,265
88	450	10.0	16,395	16,000	15,875	16,000	15,875
90	452	10.0	15,875	16,000	NR	15,625	15,625
90	450	10.0	16,000	16,130	15,625	15,385	16,000
90	446	10.0	B	B	B	B	B
92	452	10.0	15,875	15,748	NR	NR	NR

(Continued)

* NR indicates that no signal passed through the concrete at this data point; B indicates that access to this data point was blocked.

Table 1 (Continued)

Station	Elevation ft	Path Length ft	Velocity, ft/sec				
			Pier No.	Pier No.	Pier No.	Pier No.	Pier No.
			7	8	9	10	11
92	451	10.0	11,765	15,505	NR	8,695	14,490
92	448	10.0	B	B	B	B	B
93	452	10.0	13,985	15,505	NR	8,695	11,765
93	446	10.0	14,490	16,000	NR	15,750	15,875
94	450	10.0	14,490	7,780	NR	NR	6,625
94	444	10.0	16,530	16,000	15,750	15,750	15,875
96	450	10.0	NR	NR	NR	NR	NR
96	448	10.0	NR	NR	NR	7,845	NR
96	446	10.0	15,750	11,235	15,385	12,820	15,750
96	444	10.0	15,505	12,740	15,750	15,150	15,750
97	448	10.0	NR	NR	NR	NR	NR
97	444	10.0	12,500	NR	14,925	11,430	14,815
98	444	10.0	NR	NR	11,300	NR	NR

Station	Elevation ft	Path Length ft	Velocity, ft/sec			
			Pier No.	Pier No.	Pier No.	Pier No.
			12	13	14	15
88	452	10.0	15,625	15,750	15,625	15,505
88	450	10.0	15,875	16,000	14,600	16,000
90	452	10.0	15,750	NR	NR	15,385
90	450	10.0	NR	14,925	8,265	15,875
90	446	10.0	B	B	B	B
92	452	10.0	15,625	NR	NR	15,150
92	451	10.0	NR	NR	NR	15,385
92	448	10.0	B	B	B	B
93	452	10.0	8,335	NR	NR	NR
93	446	10.0	NR	6,450	15,505	NR
94	450	10.0	6,495	NR	NR	6,800
94	444	10.0	15,625	15,875	15,875	7,465
96	450	10.0	NR	NR	NR	NR

(Continued)

(Sheet 2 of 3)

Table 1 (Concluded)

Station	Elevation ft	Path Length ft	Velocity, ft/sec			
			Pier No. 12	Pier No. 13	Pier No. 14	Pier No. 15
96	448	10.0	14,490	8,000	8,695	7,405
96	446	10.0	14,815	15,505	14,815	14,925
96	444	10.0	15,385	15,035	15,385	NR
97	448	10.0	11,300	NR	NR	8,770
97	444	10.0	14,925	14,600	14,815	NR
98	444	10.0	14,285	NR	NR	12,345

Table 2
Velocity Measurements Through Columns

Station	Elevation ft	Path Length ft	Velocity, fps							
			Pier No. 2		Pier No. 9		Pier No. 16			
			Column 1	Column 4	Column 1	Column 4	Column 1	Column 4	Column 1	Column 4
71	470	3.5	7,955	8,535	5,735	5,470	6,480	**4,270		
71	469	3.5	7,445	8,535	6,365	7,690	5,735	**7,690		
71	468	3.5	7,215	9,460	7,000	11,290	5,785	12,070		
71	467	3.5	7,215	10,145	5,385	10,605	9,335	12,500		
71	466	3.5	5,555*	10,000	5,470	10,295	10,295	14,000		
71	465	3.5	4,485*	9,460	10,000	10,145	9,860	14,585		
71	464	3.5	6,420	9,460	10,295	9,460	6,140	15,555		

* Spalling or pressure lifting of concrete on upstream side of column (Station 67.5).

** Concrete was patched or repaired on downstream side of column (Station 71.0).

Table 3
Velocity Measurements Through Columns, Pier No. 16

Station No.	Elevation ft	Path Length ft	Velocity, fps		Shot Direction*
			Column 1	Column 4	
71	460.0	3.5	12,195	14,520	N & S
71	462.0	3.5	11,515	14,405	N & S
68.25	460.0	3.0	13,045	14,565	E & W
68.25	462.0	3.0	11,235	14,635	E & W
68.25	464.0	3.0	10,910	14,355	E & W

Station No.	Elevation ft	Path Length ft	Velocity, fps		
			A**	B	C
71	468.0	1.5	9,375	7,895	9,675

Station No.	Elevation ft	Path Length ft	Velocity, fps		Shot Direction*
			Column 2	Column 3	
57.3	460.0	3.5	8,950	14,585	N & S
57.3	462.0	3.5	9,090	15,020	N & S
57.3	464.0	3.5	10,070	14,895	N & S
59.05	460.0	3.0	9,525	14,780	E & W
59.05	462.0	3.0	9,435	15,000	E & W
59.05	464.0	3.0	10,135	15,230	E & W

* Assuming upstream to be north.

** Measurements A, B, and C were made above the opening between Columns 1 and 4.

PIER NO. 2

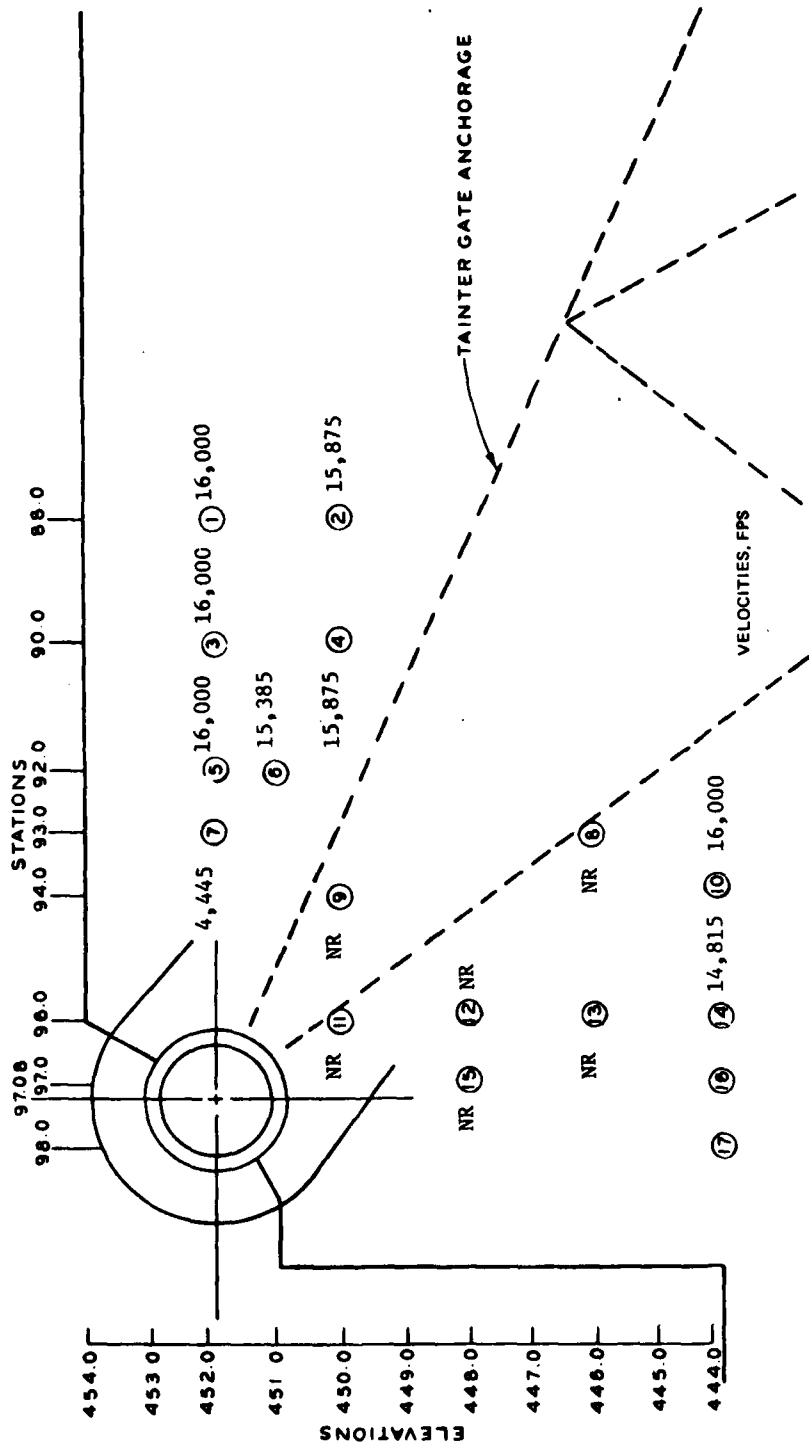

Figure 1. Velocities (fps), stations and elevations of data points, Pier No. 2

PIER NO. 3

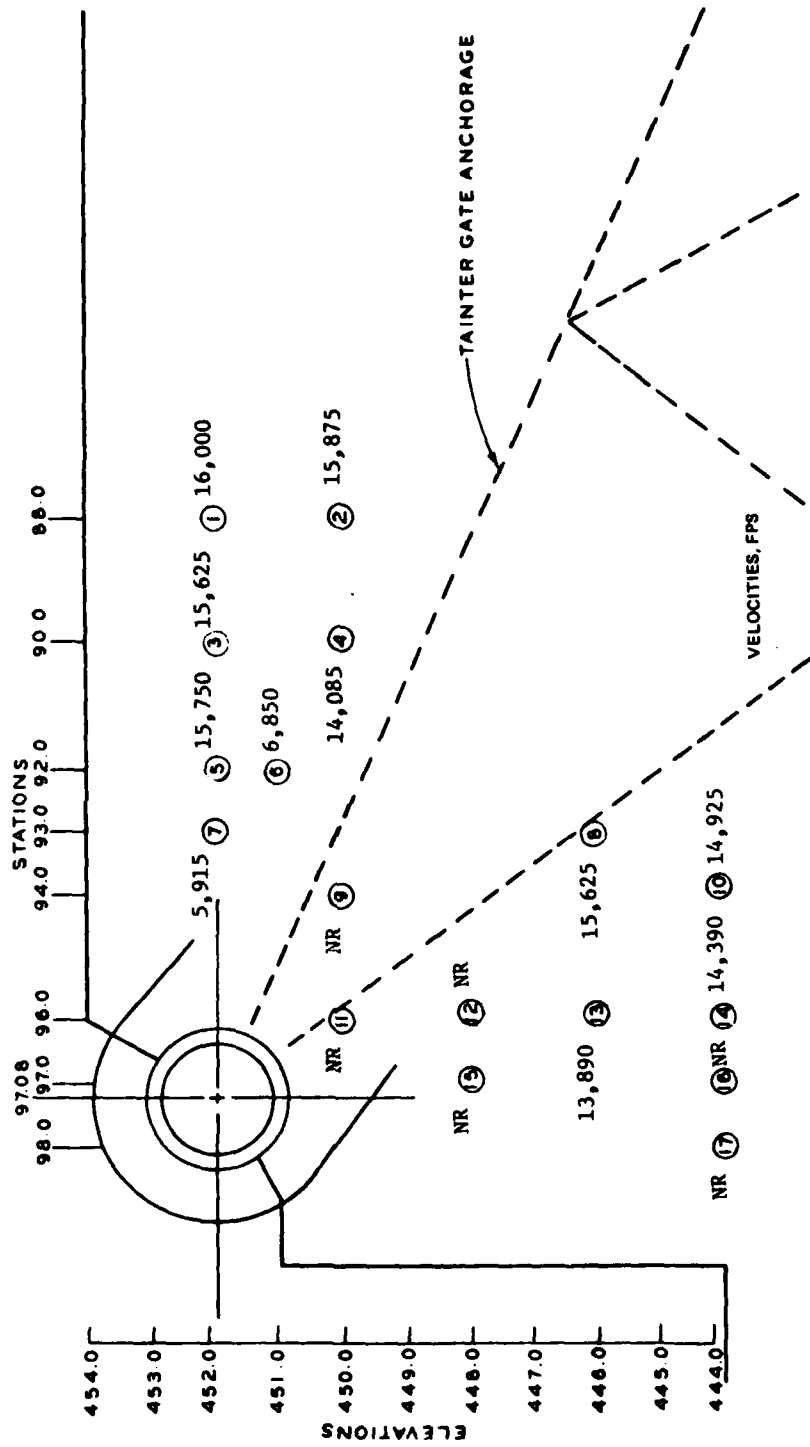

Figure 2. Velocities (fps), stations and elevations of data points, Pier No. 3

PIER NO. 4

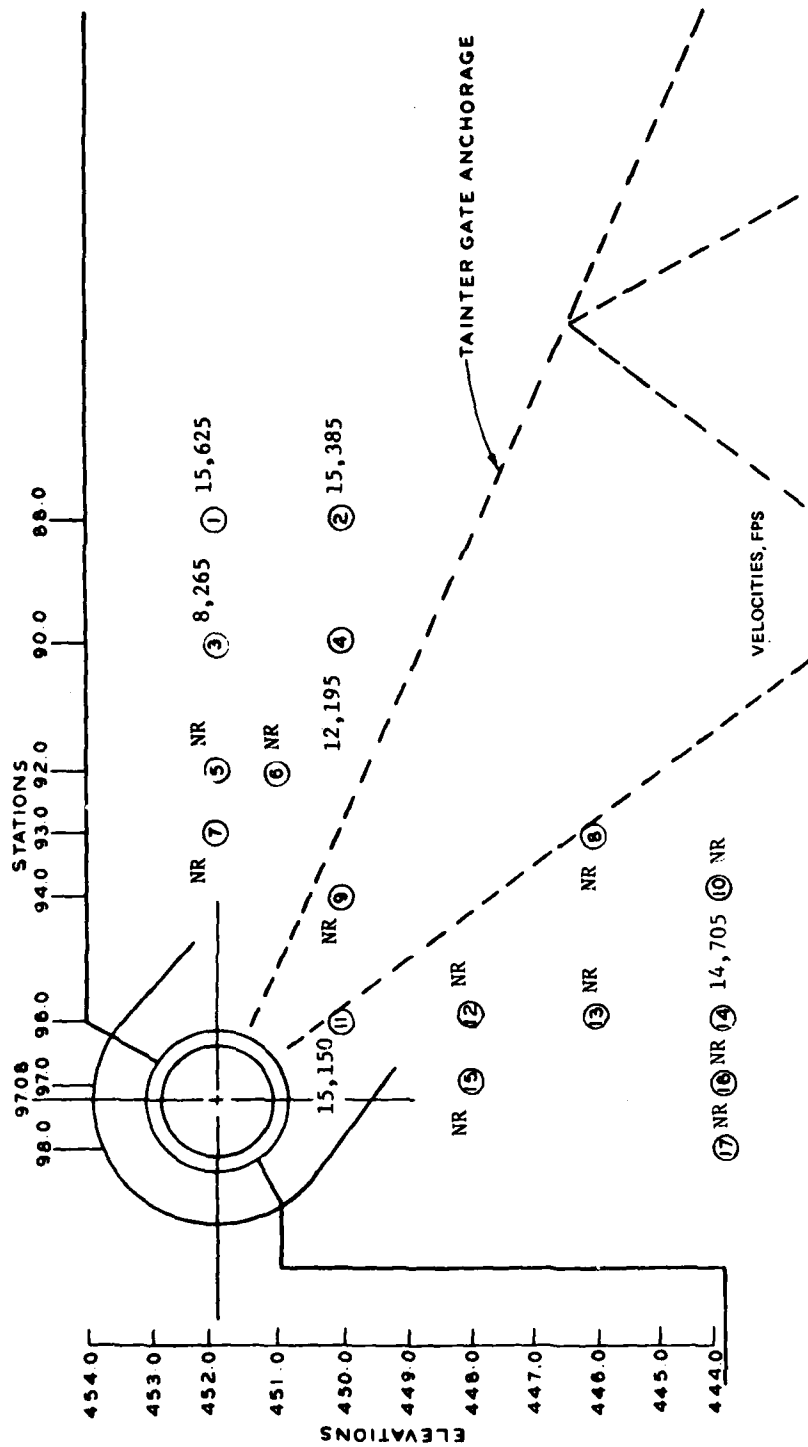

Figure 3. Velocities (fps), stations and elevations of data points, Pier No. 4

PIER NO. 5

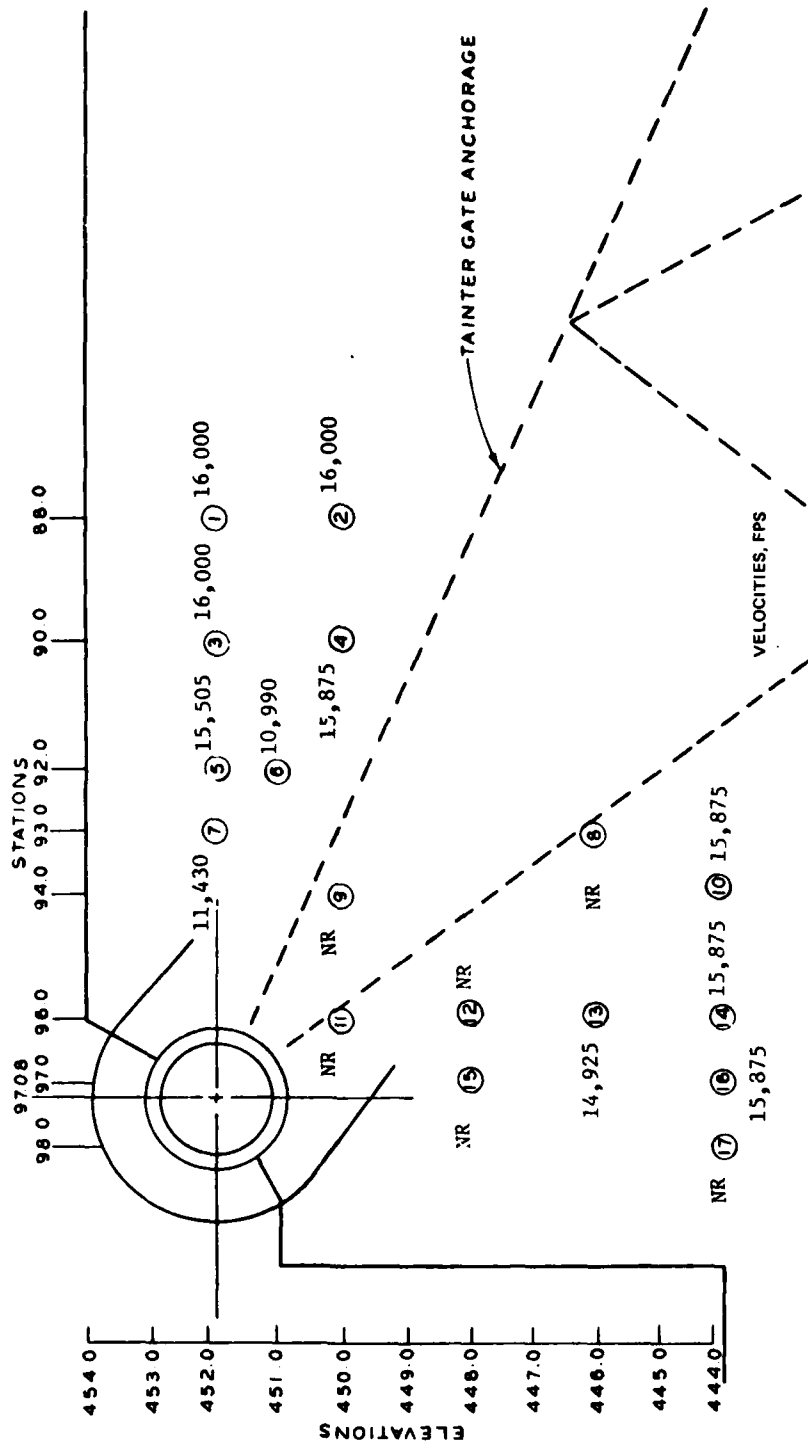

Figure 4. Velocities (fps), stations and elevations of data points, Pier No. 5

PIER NO. 6

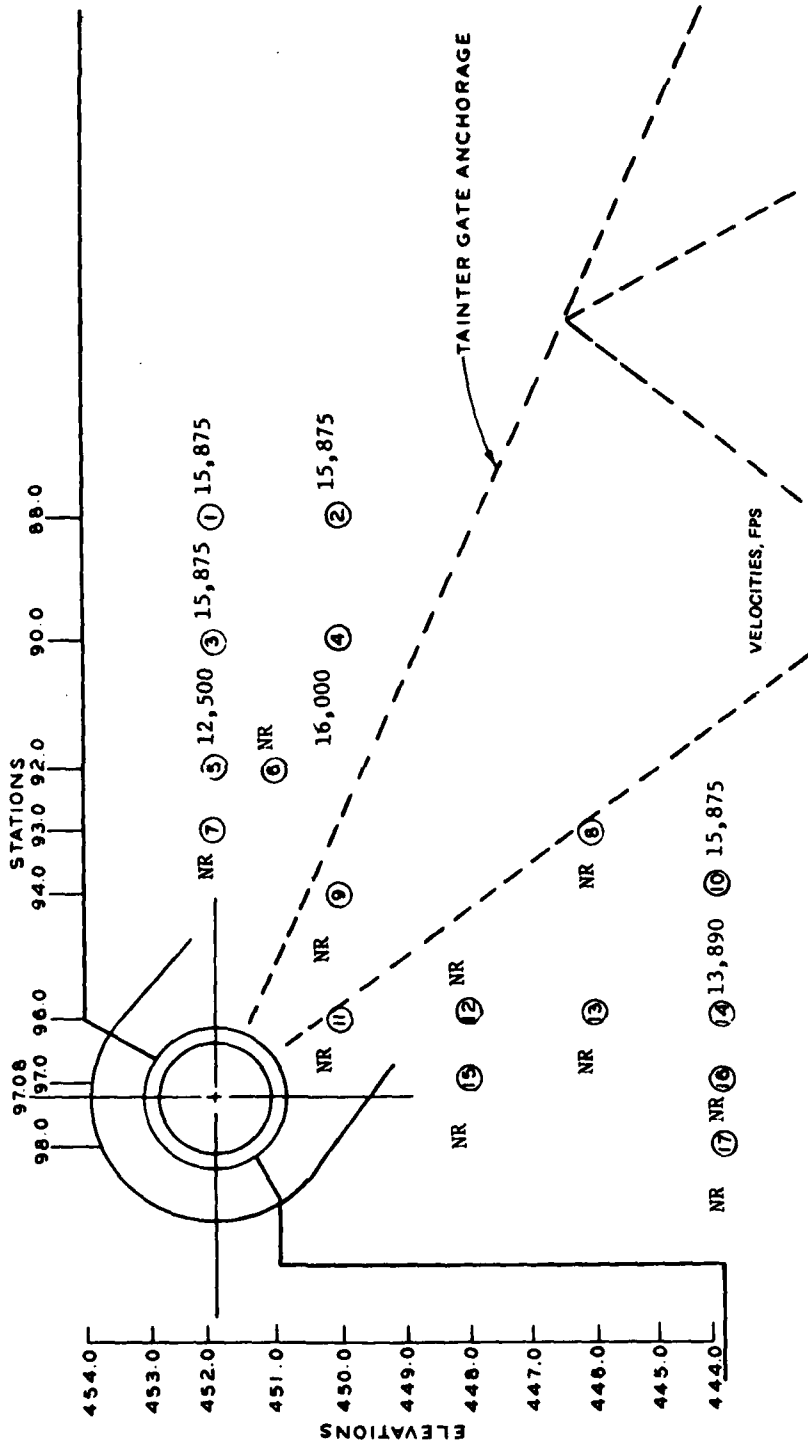

Figure 5. Velocities (fps), stations and elevations of data points, Pier No. 6

PIER NO. 7

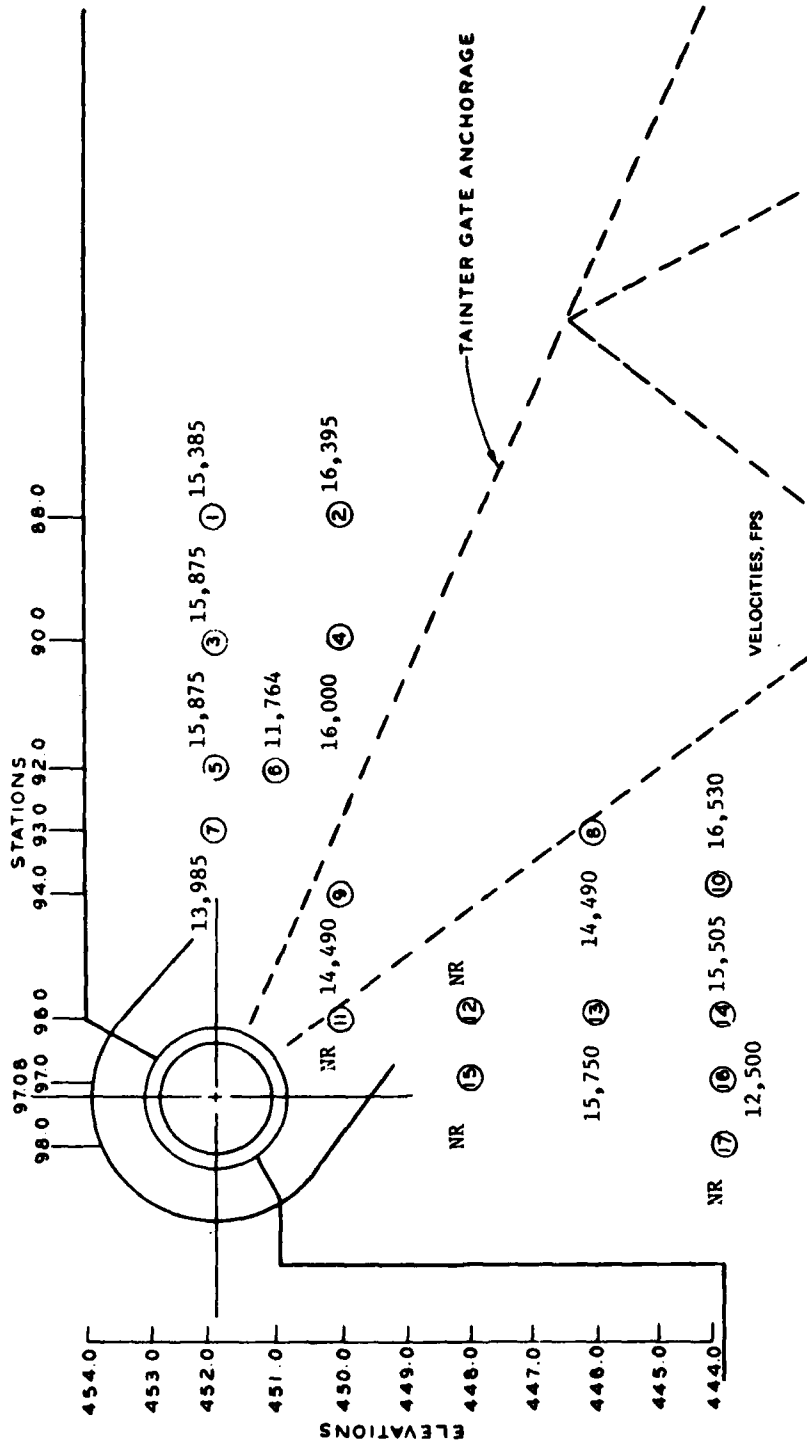

Figure 6. Velocities (fps), stations and elevations of data points, Pier No. 7

PIER NO. 8

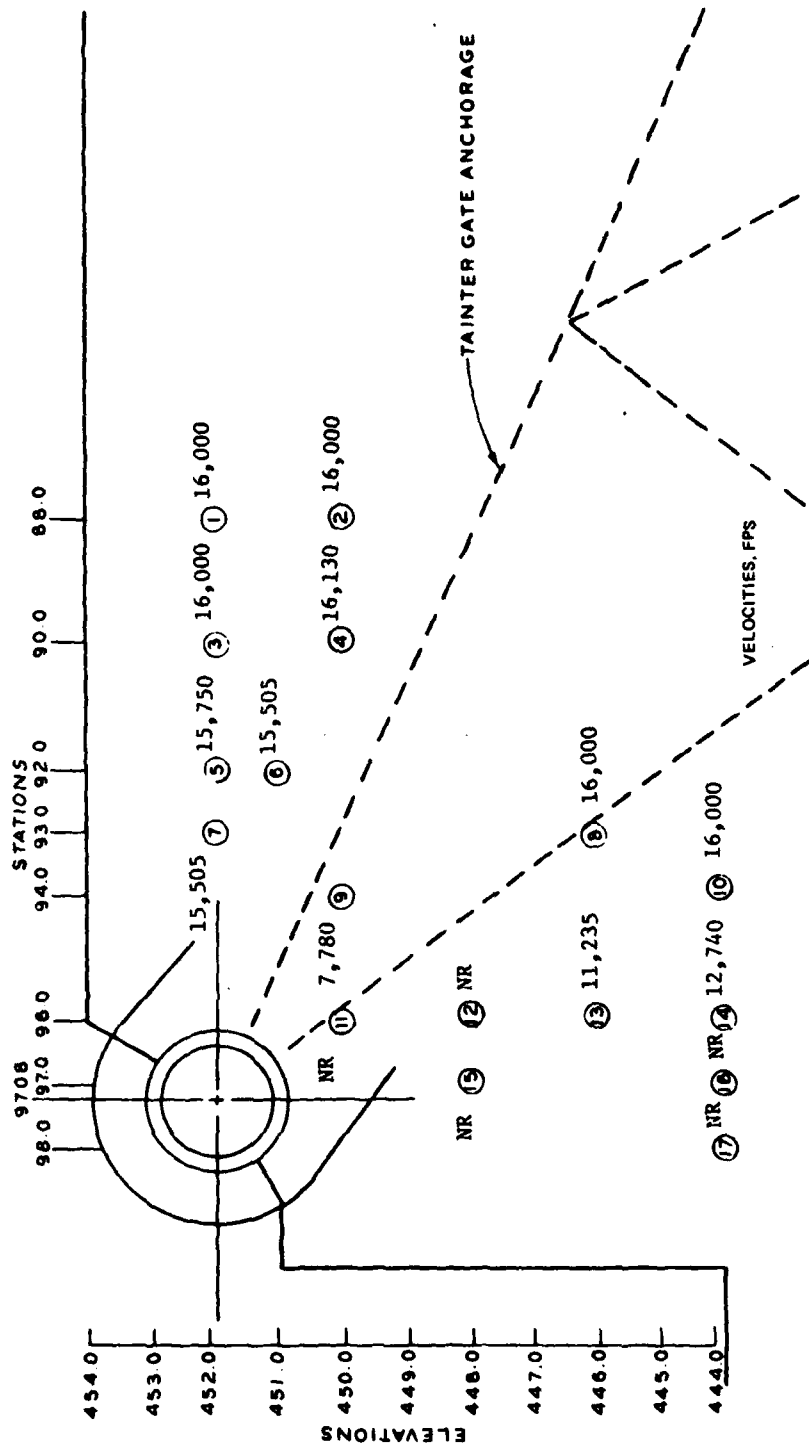

Figure 7. Velocities (fps), stations and elevations of data points, Pier No. 8

PIER NO. 9

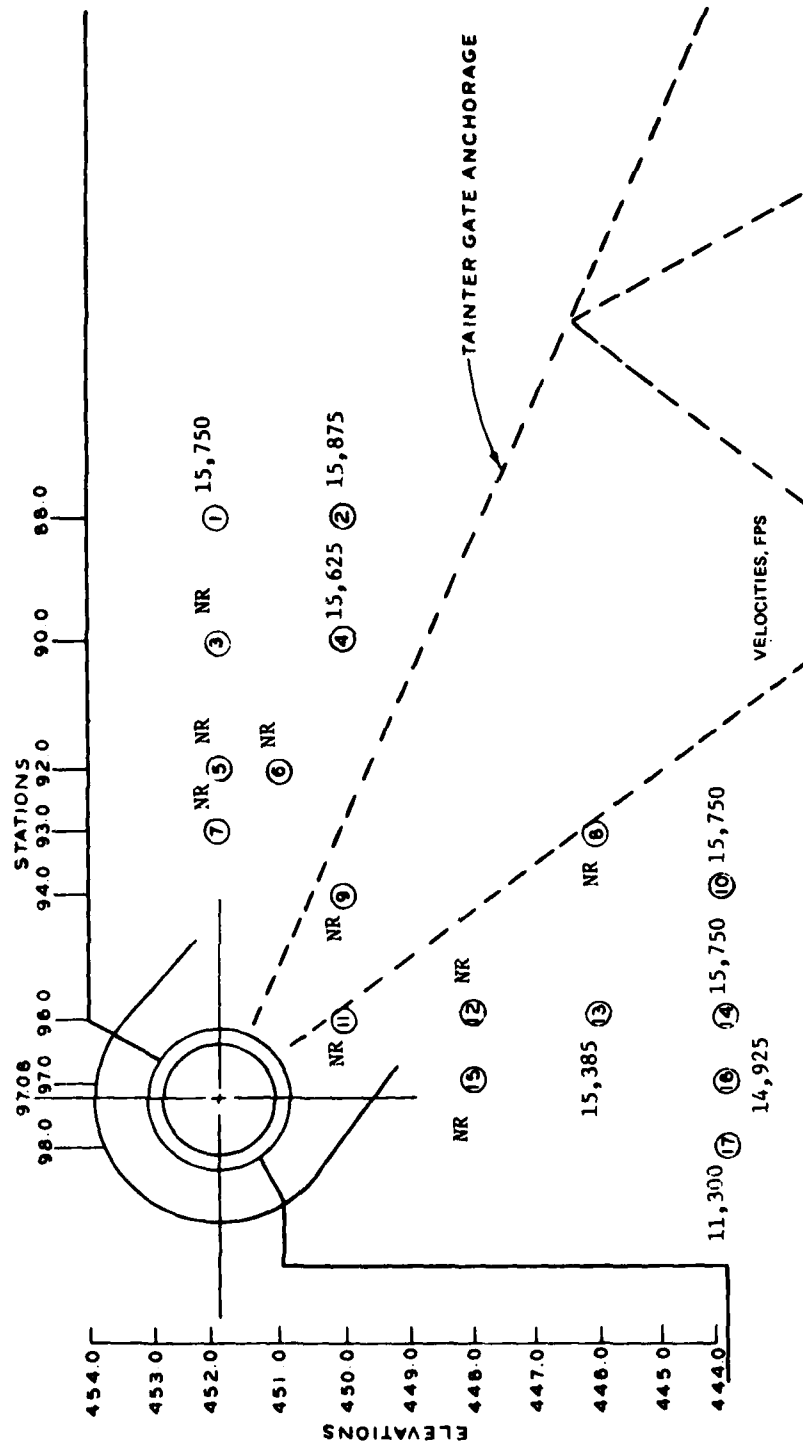
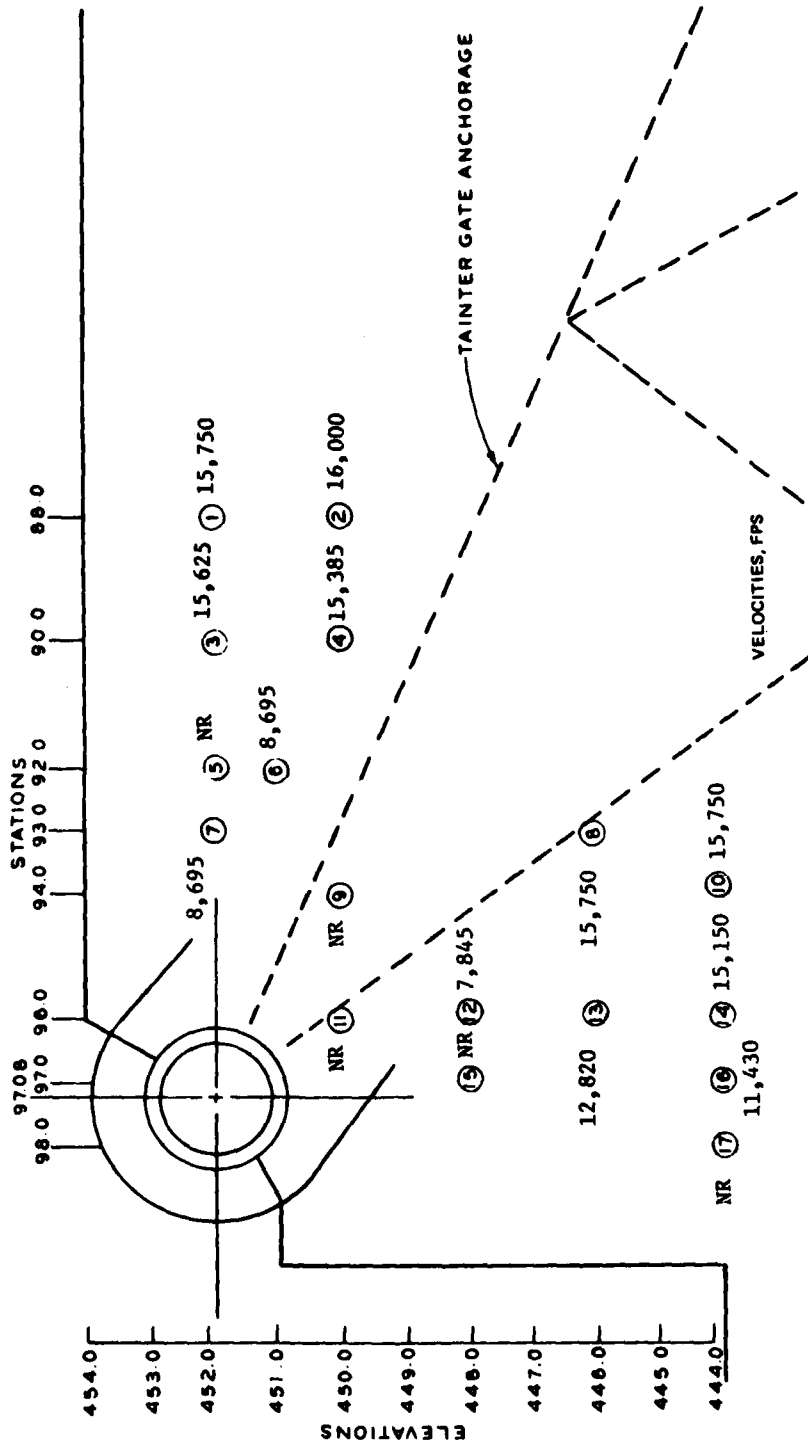

Figure 8. Velocities (fps), stations and elevations of data points, Pier No. 9

PIER NO. 10



PIER NO. 11

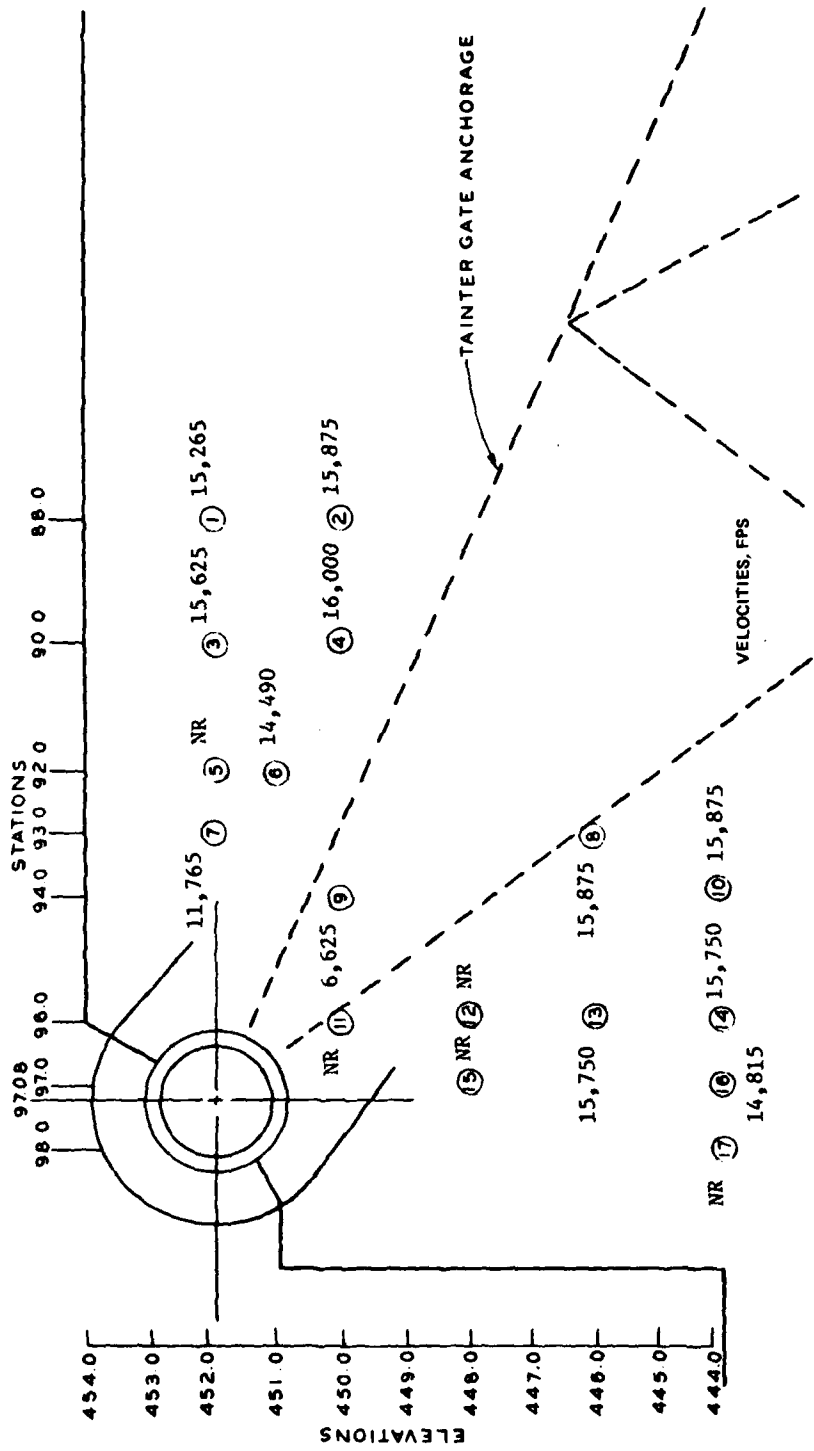

Figure 10. Velocities (fps), stations and elevations of data points, Pier No. 11

PIER NO. 12

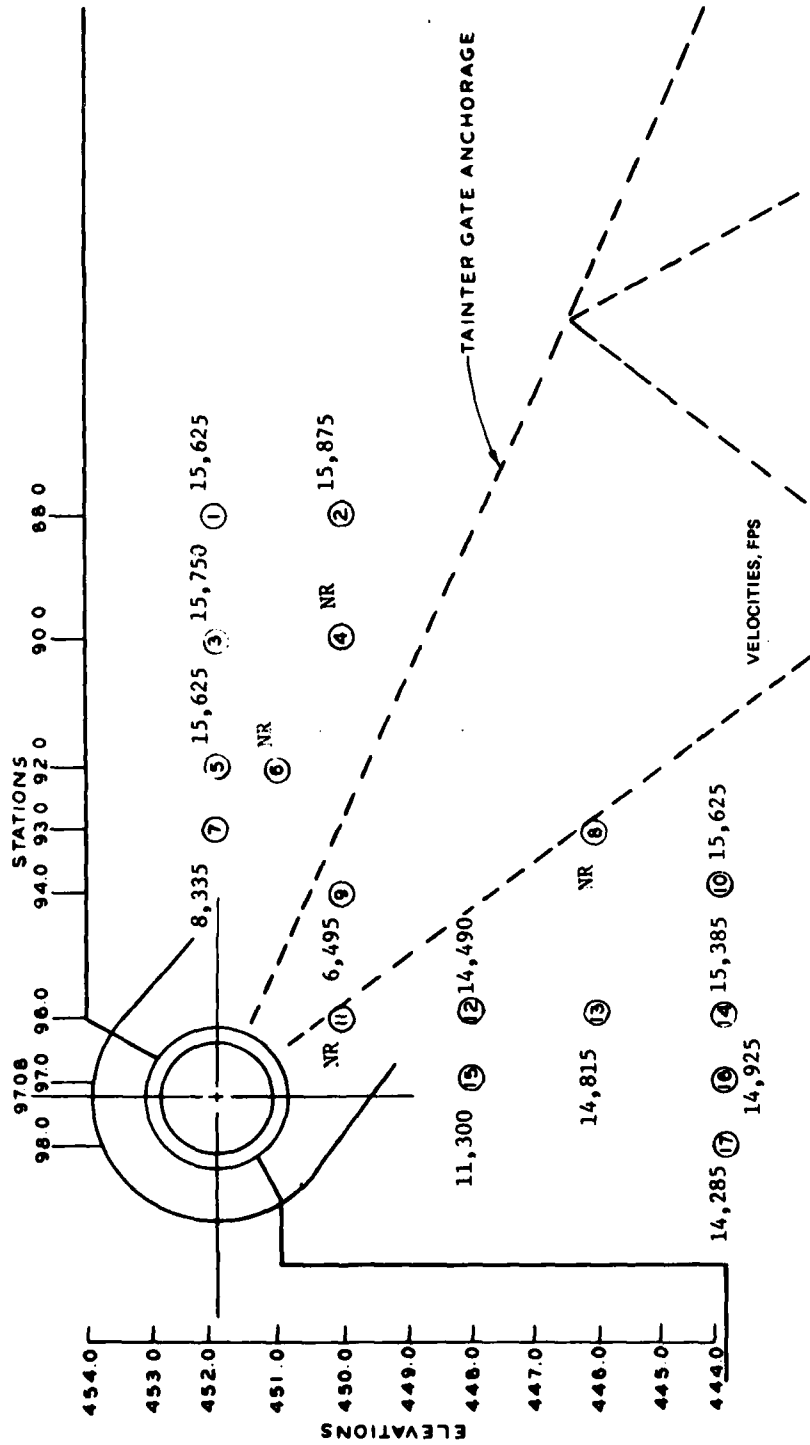

Figure 11. Velocities (fps), stations and elevations of data points, Pier No. 12

PIER NO. 13

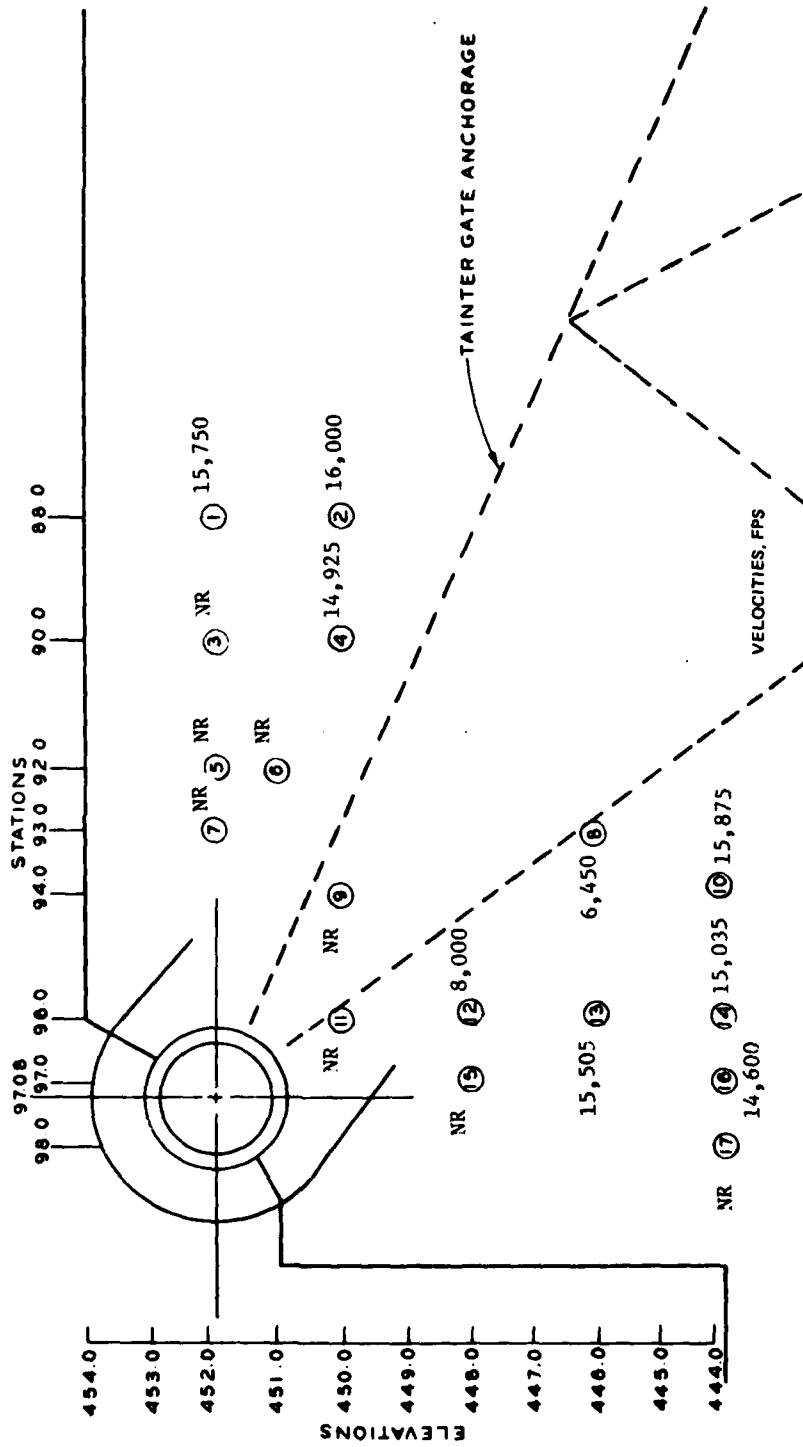

Figure 12. Velocities (fps), stations and elevations of data points, Pier No. 13

PIER NO. 14

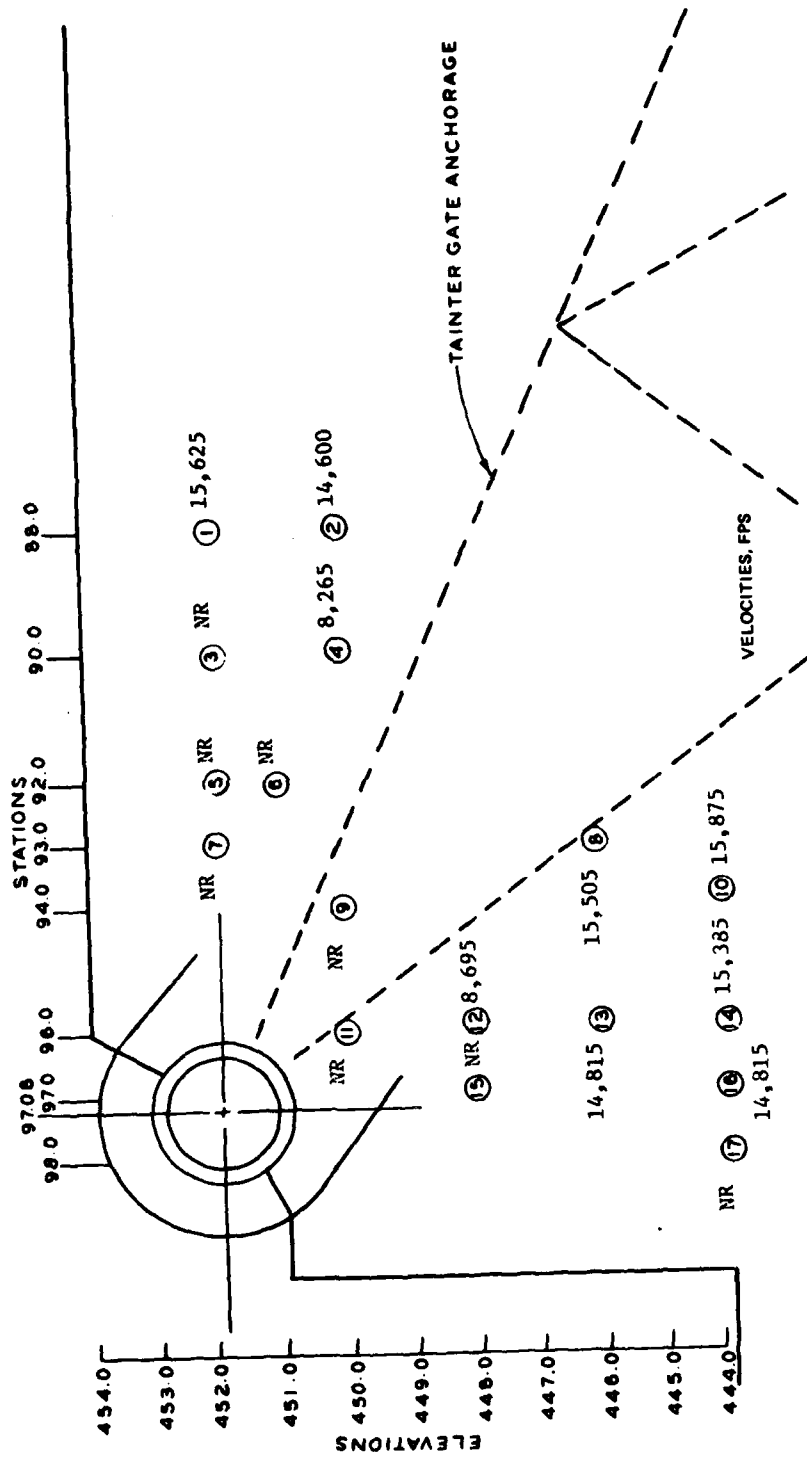

Figure 13. Velocities (fps), stations and elevations of data points, Pier No. 14

PIER NO. 15

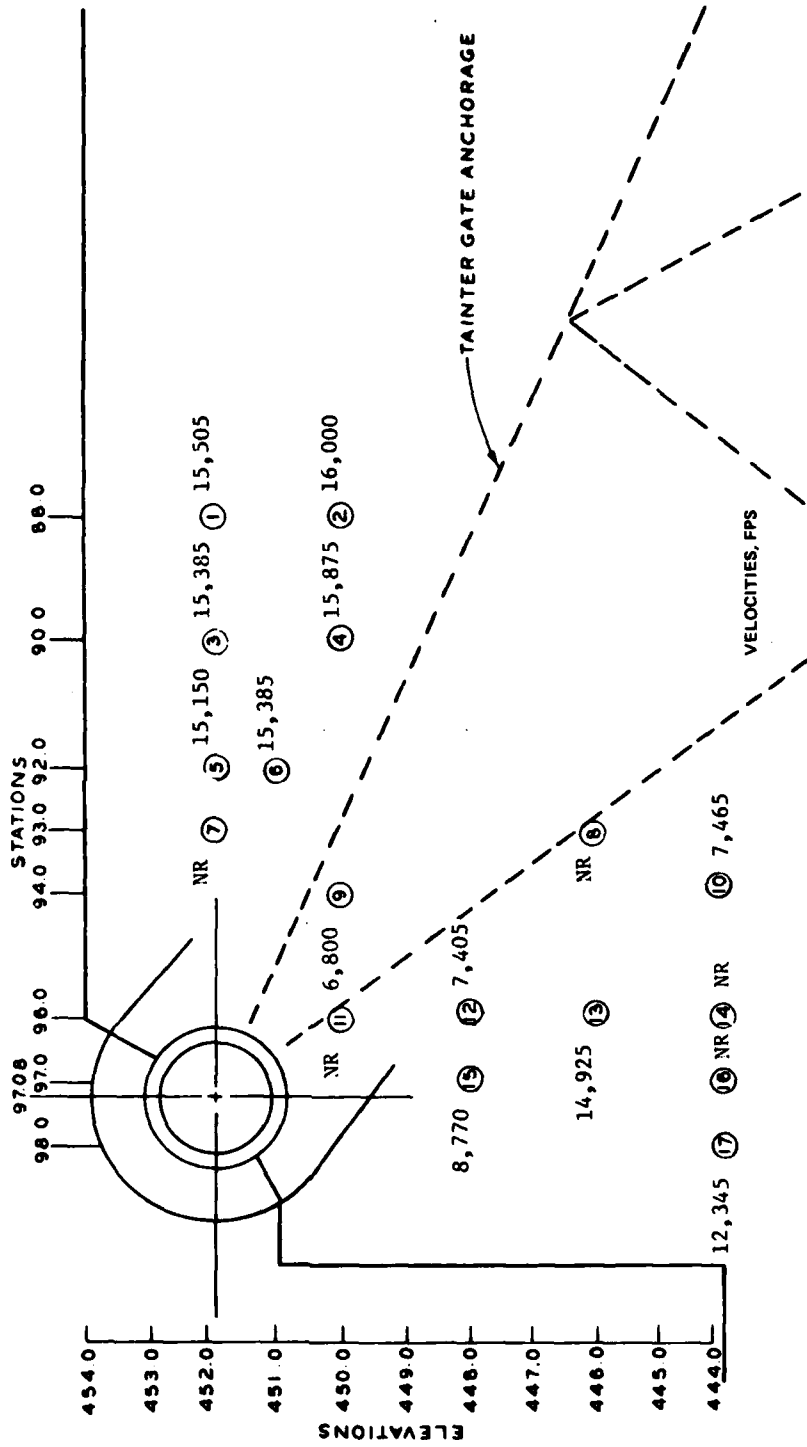

Figure 14. Velocities (fps), stations and elevations of data points, Pier No. 15

LOCK AND DAM NO. 24

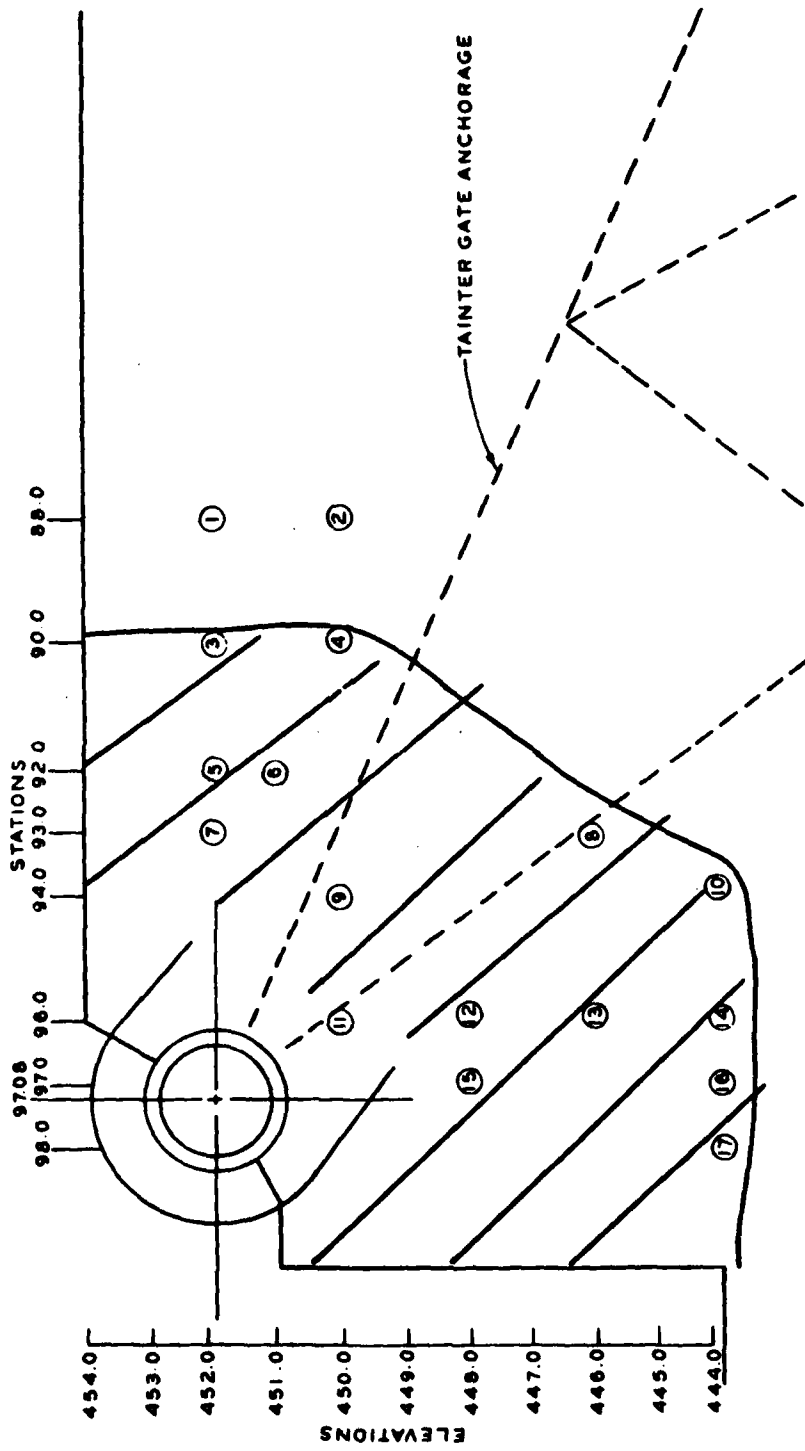

Figure 15. General area of indicated deterioration, Piers No. 2-15

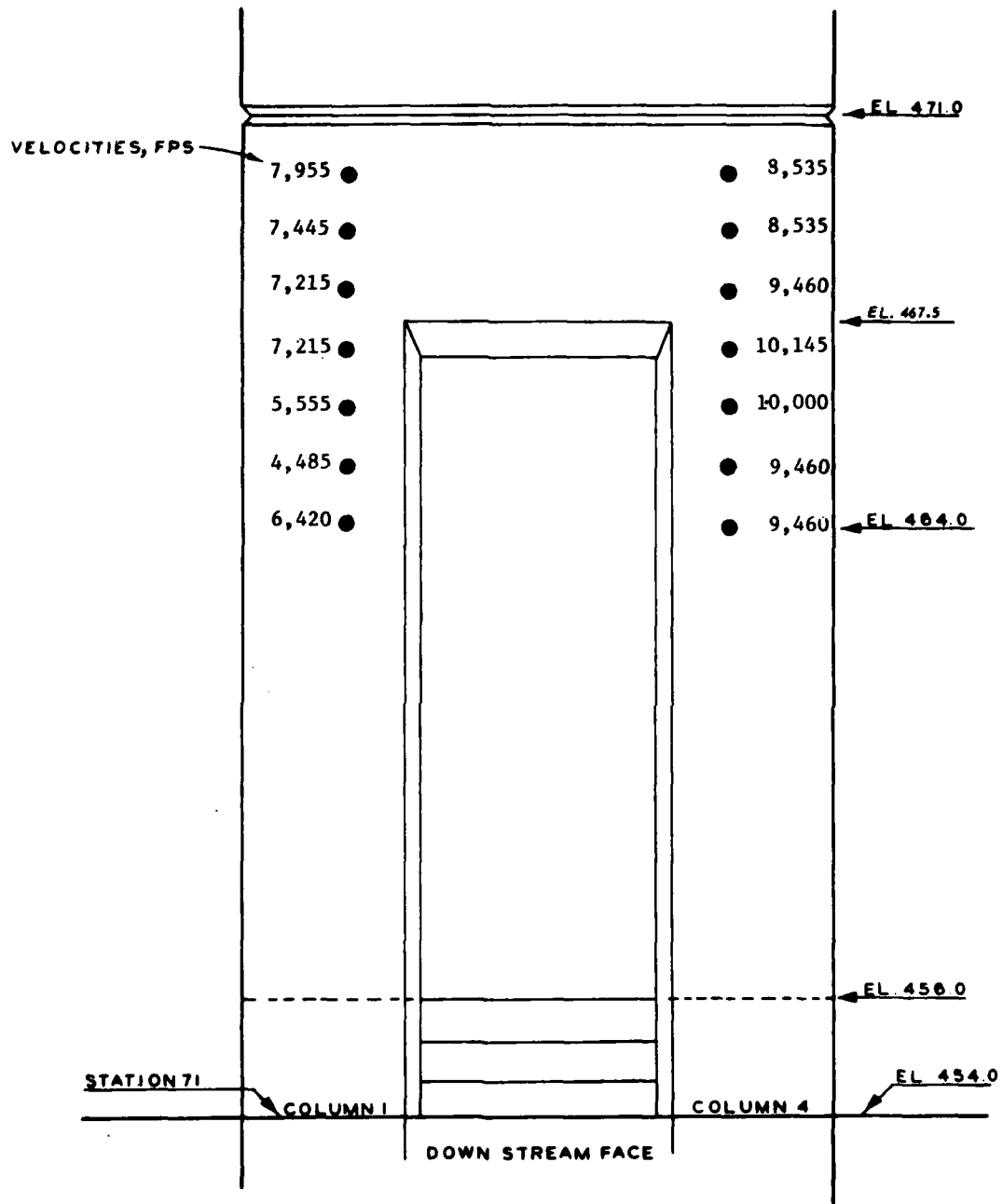

Figure 16. Pier No. 2, station and elevations of data points

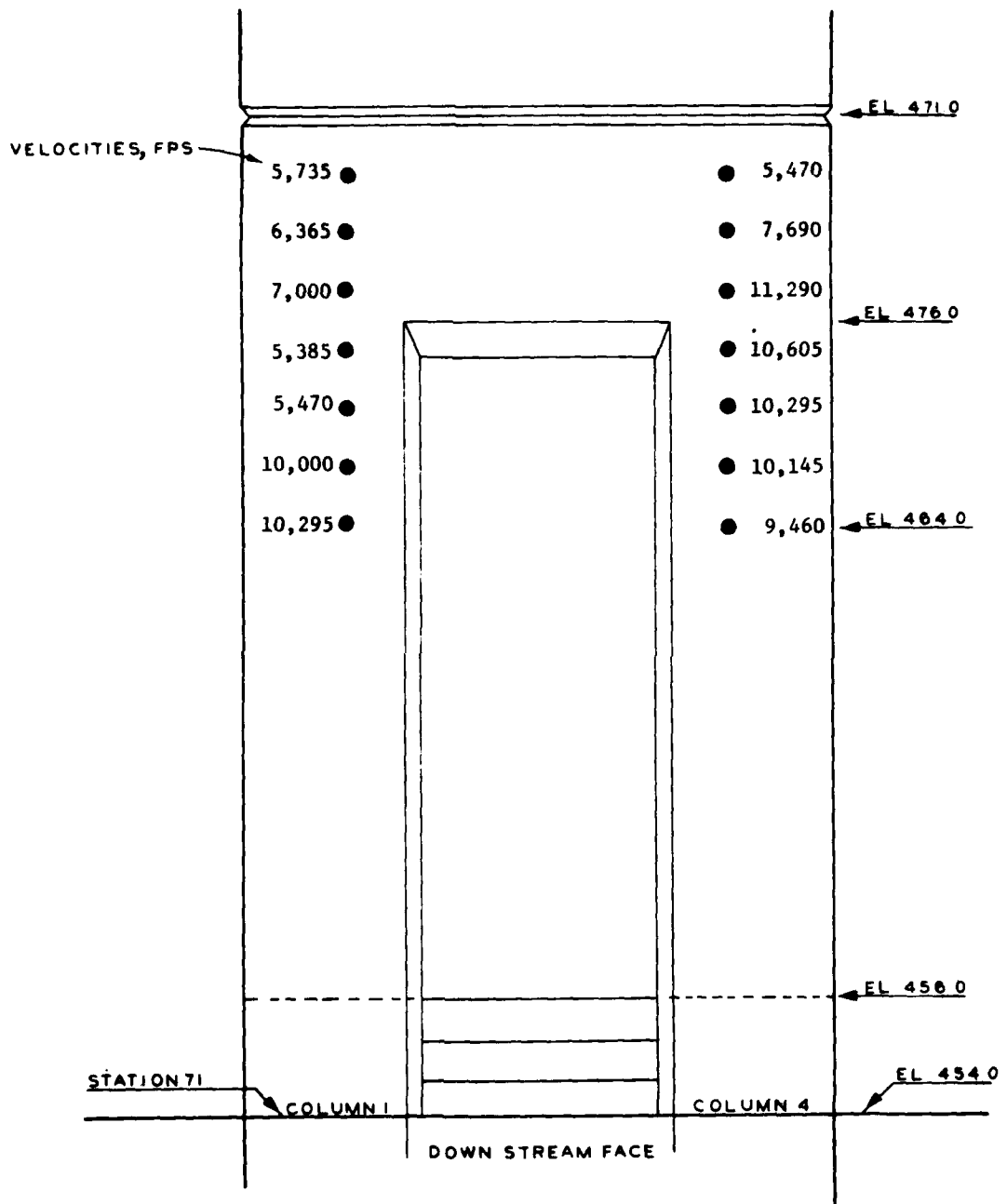

Figure 17. Pier No. 9, station and elevations of data points

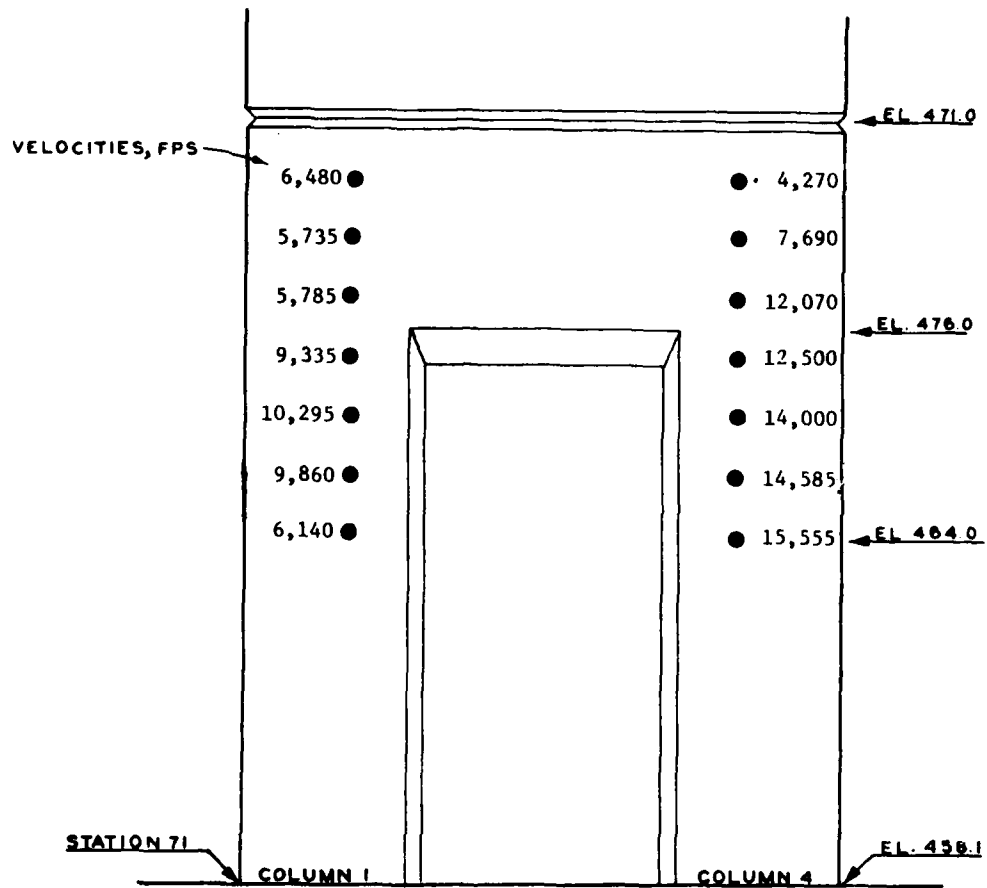

Figure 18. Pier No. 16, station and elevations of data points

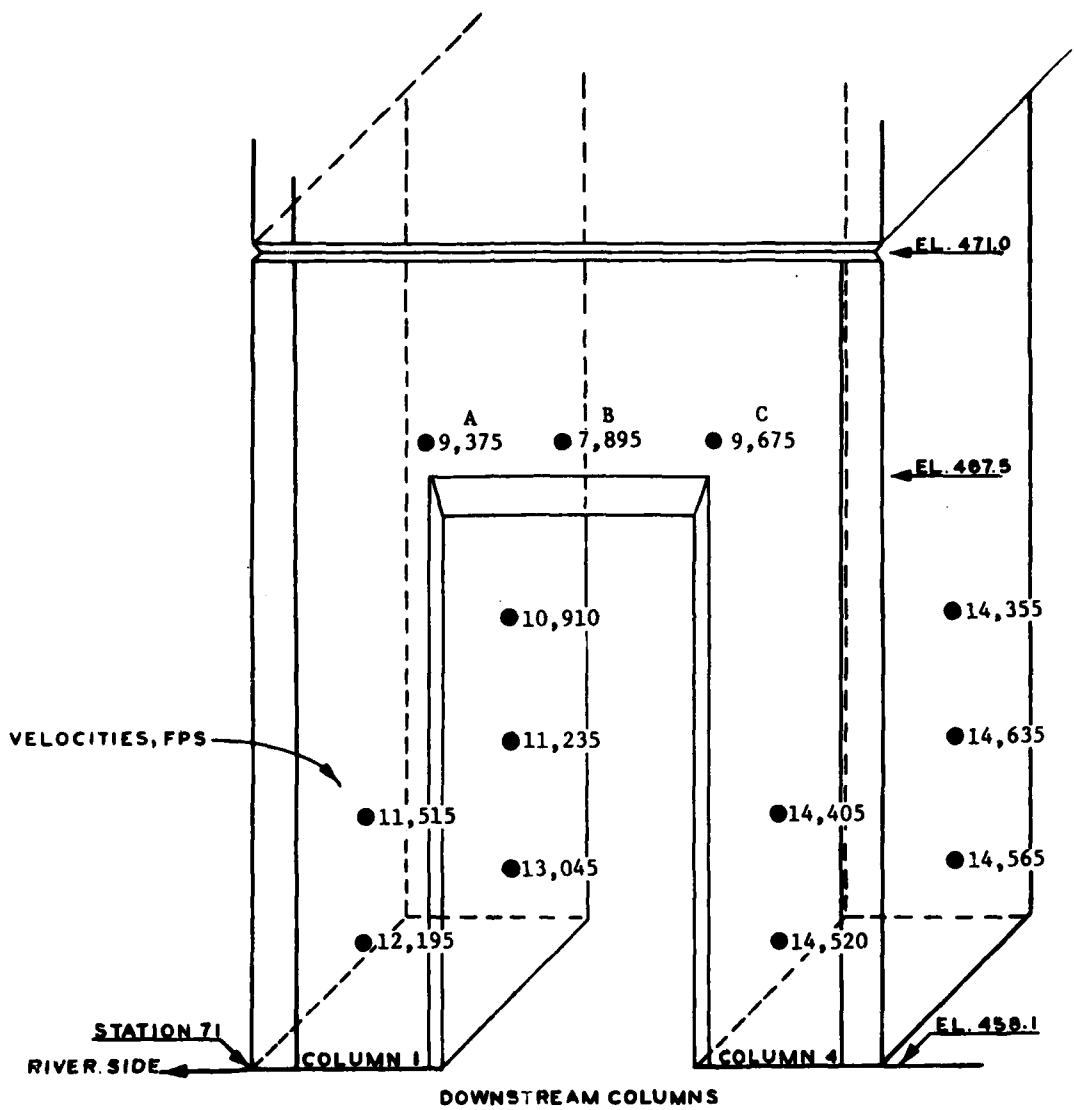

Figure 19. Pier No. 16, station and elevations of data points

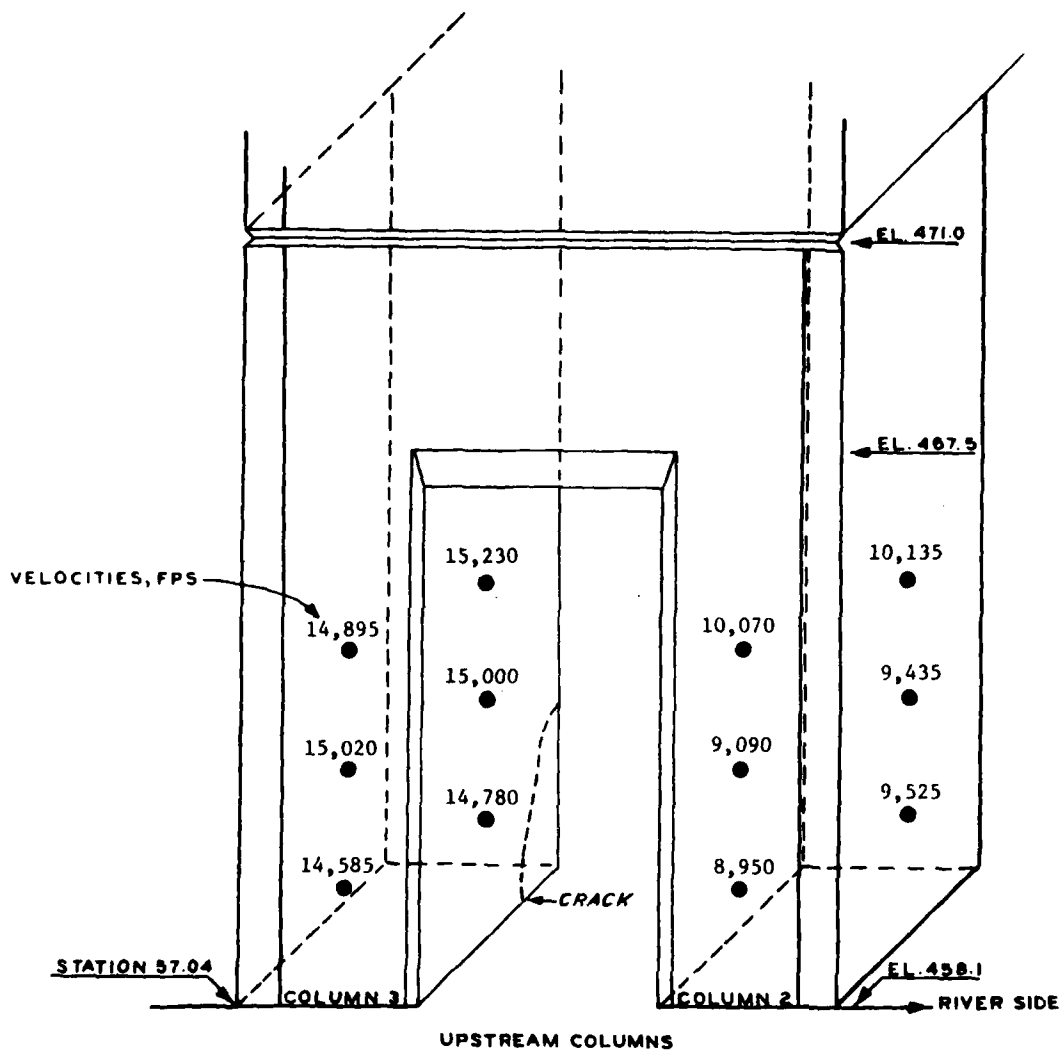

Figure 20. Pier No. 16, station and elevations of data points

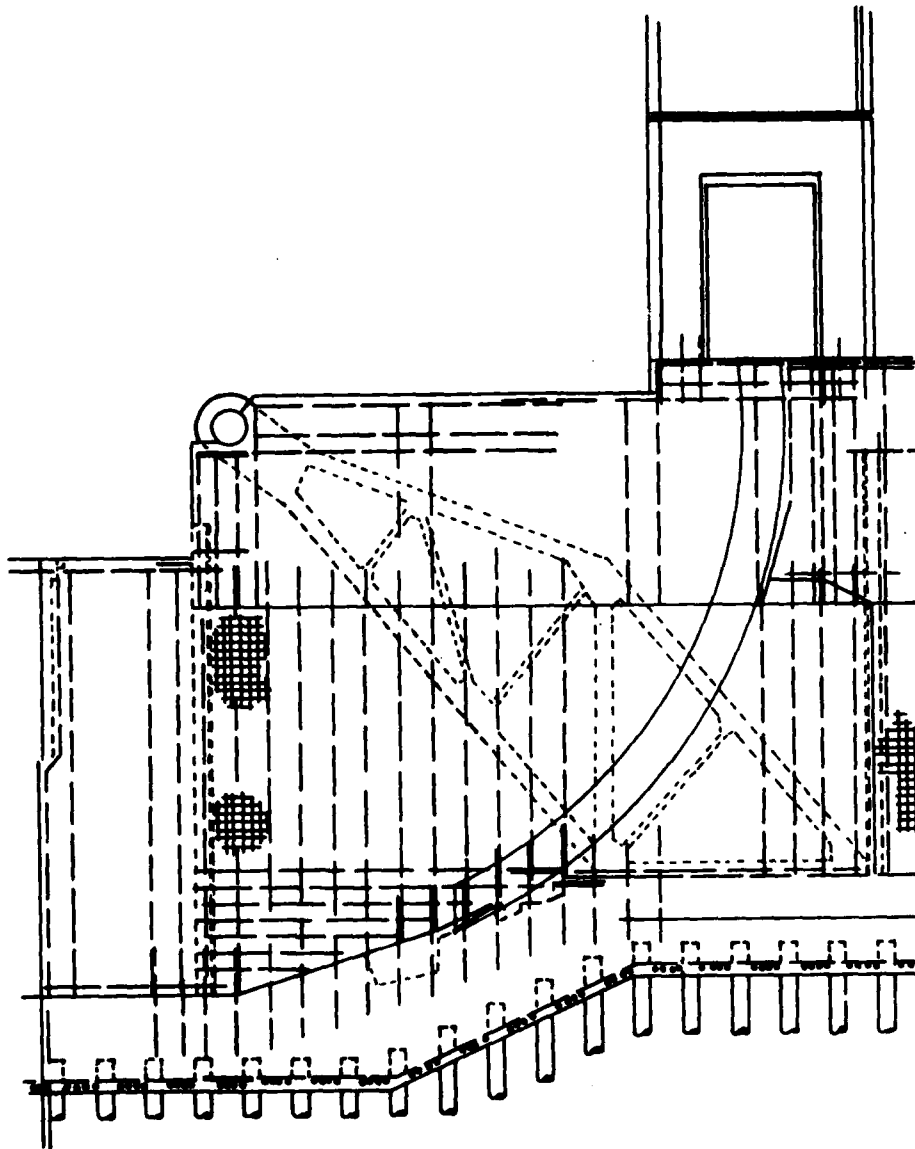

Figure 21. Typical pier elevation showing location of tainter gate tension anchorage

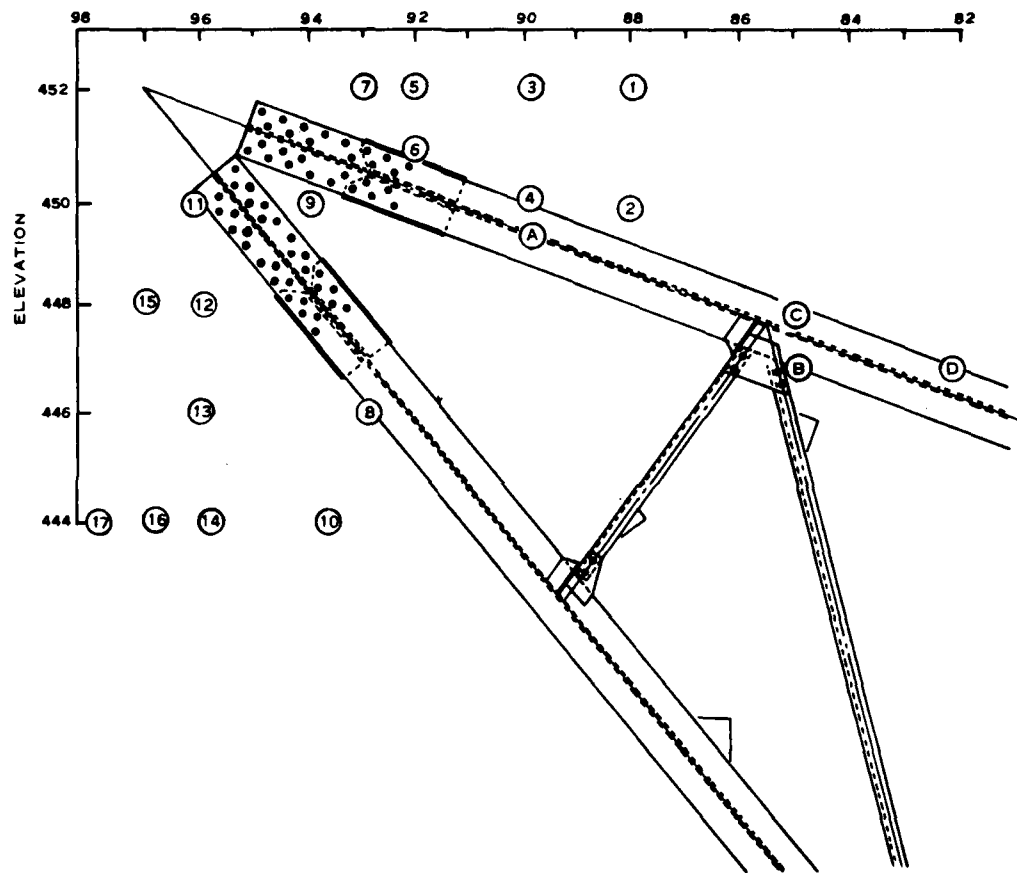

Figure 22. Location of velocity data points with respect to embedded tension anchorage beams

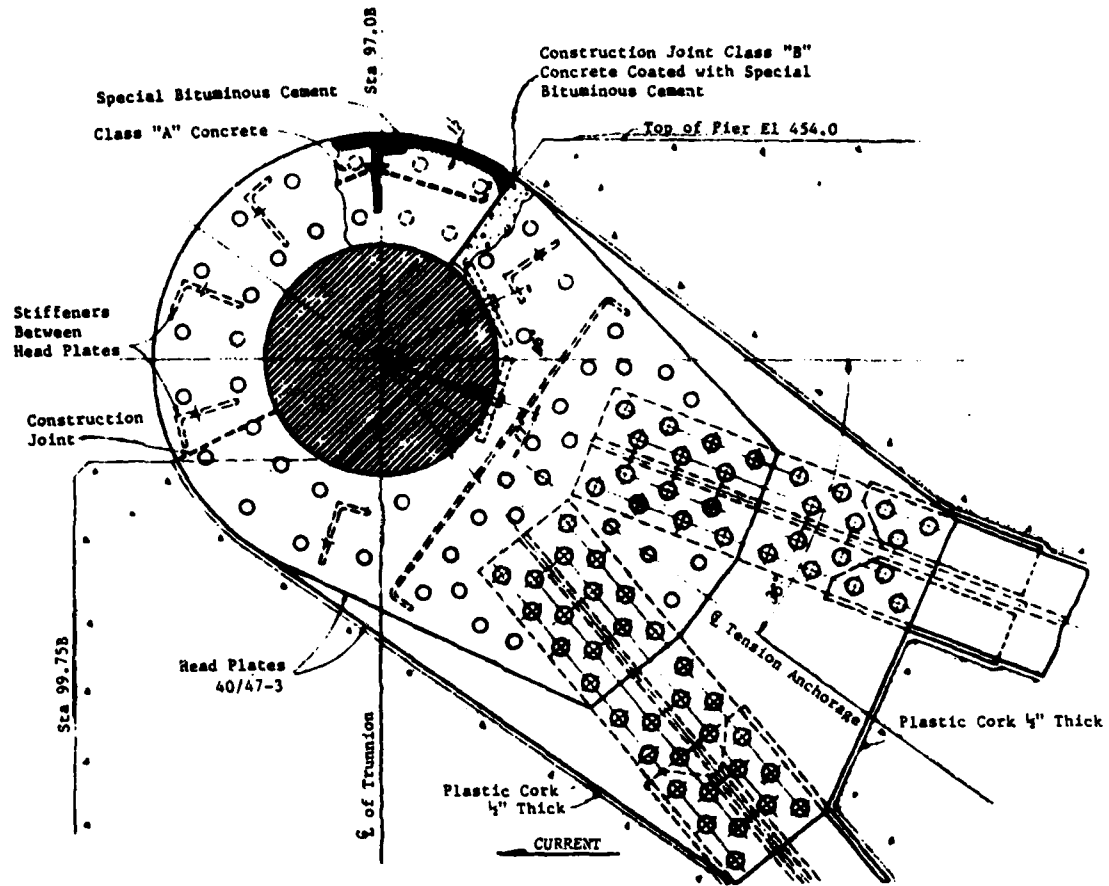

Figure 23. Detail of trunnion, head plates, and anchorage beam connections

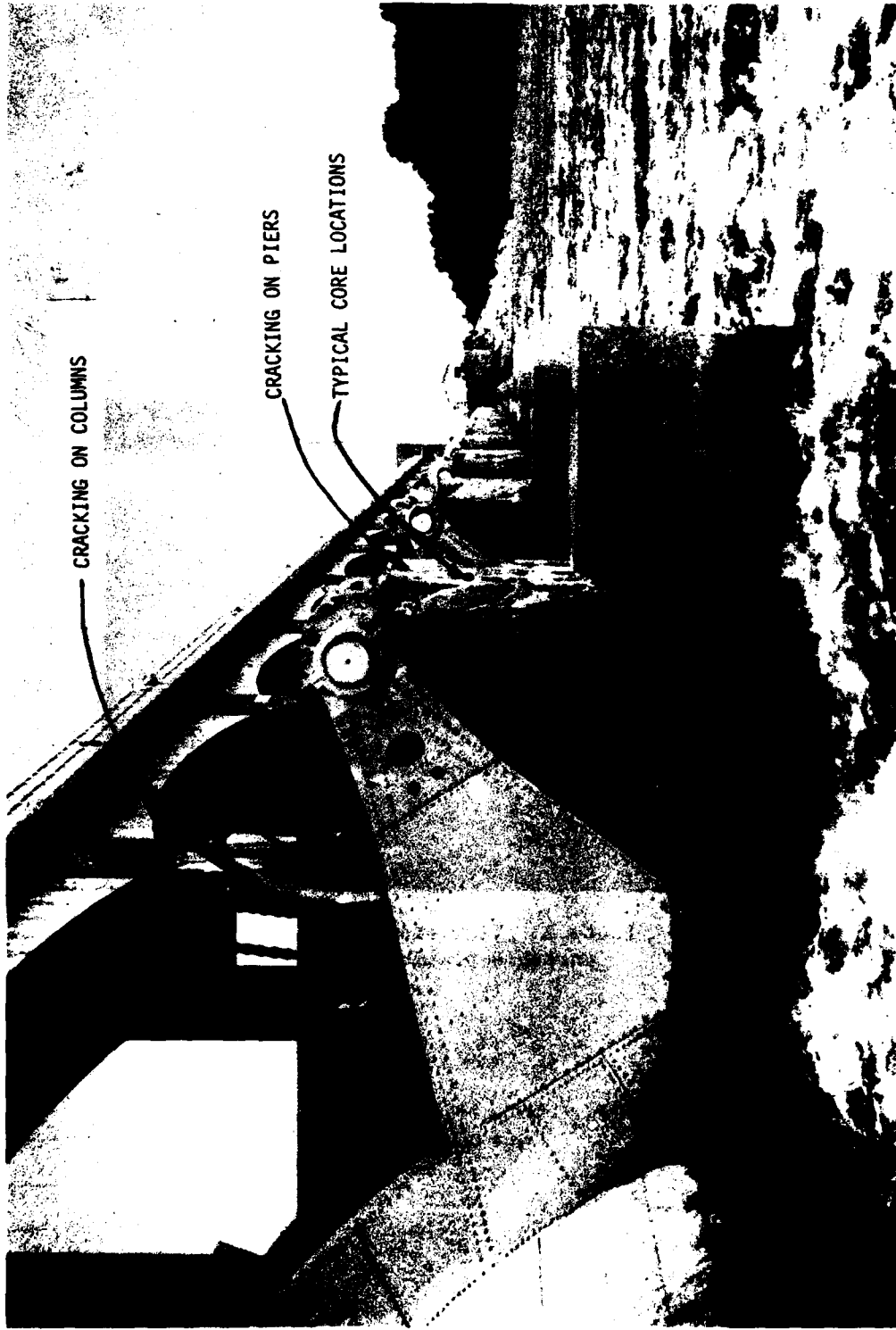

Photo 1. Pier No. 2



Photo 2. View showing
portable platform

In accordance with letter from DAEN-RDC, DAEN-ASI dated 22 July 1977, Subject: Facsimile Catalog Cards for Laboratory Technical Publications, a facsimile catalog card in Library of Congress MARC format is reproduced below.

Thornton, Henry T

Ultrasonic velocity measurements in concrete, Lock and Dam No. 24, Mississippi River / by Henry T. Thornton, Jr., Dale Glass. Vicksburg, Miss. : U. S. Waterways Experiment Station ; Springfield, Va. : available from National Technical Information Service, 1980.

13, [30] p. : ill. ; 27 cm. (Miscellaneous paper - U. S. Army Engineer Waterways Experiment Station ; SL-80-2)

Prepared for U. S. Army Engineer District, St. Louis, St. Louis, Missouri.

1. Alkali aggregate reactions. 2. Concrete cracking. 3. Deterioration. 4. Freeze-thaw. 5. Lock and Dam No. 24, Mississippi River. 6. Nondestructive tests. 7. Performance. 8. Structural behavior. 9. Ultrasonic velocity. I. Glass, Dale, joint author. II. United States. Army. Corps of Engineers, St. Louis. III. Series: United States. Waterways Experiment Station, Vicksburg, Miss. Miscellaneous paper ; SL-80-2.

TA7.W34M no.SL-80-2