

AD-A084 097

NORTHEASTERN UNIV BOSTON MASS ELECTRONICS RESEARCH LAB F/G 17/2
COMMAND CONTROL CONSOLES FOR SOUNDING ROCKET PAYLOADS.(U)
DEC 79 R L MORIN F19628-76-C-0152
SCIENTIFIC-3 AFGL -TR-80-0019 NL

UNCLASSIFIED

1-1
2-1
3-1



END
DATE
FILMED
6 80
DTIC

Unclassified

MIL-STD-847A
31 January 1973

SECURITY CLASSIFICATION OF THIS PAGE (When Data Entered)

| REPORT DOCUMENTATION PAGE | | READ INSTRUCTIONS BEFORE COMPLETING FORM |
|--|---|---|
| 1. REPORT NUMBER 18 AFGL TR-86-0019 | 2. GOVT ACCESSION NO. AD-A084097 | 3. RECIPIENT'S CATALOG NUMBER |
| 4. TITLE (and Subtitle) 6 COMMAND CONTROL CONSOLES FOR SOUNDING ROCKET PAYLOADS | 5. TYPE OF REPORT & PERIOD COVERED 9 Interim <i>rept.</i> | 6. AUTHORING OR PERFORMING ORGANIZATION REPORT NUMBER |
| 7. AUTHOR 10 Richard L. Morin | 8. PERFORMING ORGANIZATION REPORT NUMBER 14 Scientific Report 3 | 9. PROGRAM ELEMENT, PROJECT, TASK AREA & WORK UNIT NUMBER 15 F19628-76-C-0152 |
| 10. PERFORMING ORGANIZATION NAME AND ADDRESS Northeastern University Electronics Research Laboratory Boston, Massachusetts 02115 | 11. CONTROLLING OFFICE NAME AND ADDRESS Air Force Geophysics Laboratory Hanscom AFB, Massachusetts 01731 Monitor: Edward F. McKenna, LCR | 12. REPORT DATE 17 23 11 December 1979 |
| 13. MONITORING AGENCY NAME & ADDRESS (if different from Controlling Office) 12 25 | 14. SECURITY CLASS. (of this report) Unclassified | 15. DECLASSIFICATION/DOWNGRADING SCHEDULE |
| 16. DISTRIBUTION STATEMENT (of this Report) Approved for public release; Distribution unlimited | | |
| 17. DISTRIBUTION STATEMENT (of the abstract entered in Block 20, if different from Report) | | |
| 18. SUPPLEMENTARY NOTES | | |
| 19. KEY WORDS (Continue on reverse side if necessary and identify by block number) Attitude control system; autotracker; command control consoles; command receiver; sequencer; sounding rocket payload; telemetry | | |
| 20. ABSTRACT (Continue on reverse side if necessary and identify by block number) Presented is a summary of the design and development of a command control system, under Contract Number F19628-76-C-0512. The objective is a real-time command and monitor console for payload functions in sounding rockets. Payload requirements, console configurations, ground support interfaces, and test results for a specific experimental payload application are described in this report. | | |

DD FORM 1473 1 JAN 73 EDITION OF 1 NOV 68 IS OBSOLETE

Unclassified

SECURITY CLASSIFICATION OF THIS PAGE (When Data Entered)

127500

1/10

ILLUSTRATIONS

| | Page |
|---|------|
| Figure 3.1 ACS Console Configuration | 4 |
| Figure 3.2 Payload Console Configuration | 5 |
| Figure 4.1 Functional Block Diagram-ACS Console | 9 |
| Figure 4.2 Functional Block Diagram-Payload Console | 10 |
| Figure 4.3 Signal Conditioning Module-Type 1 | 12 |
| Table 4.1 ACS Position and Rate Monitor | 13 |
| Table 4.2 ACS Operation Mode Monitor | 14 |
| Table 5.1 A18.805 Flight Sequence | 17 |

1.0 INTRODUCTION

The consoles described were designed to provide real-time command and monitoring of sounding rocket payload functions. These consoles were used in conjunction with an experimental payload studying post burnout thrust characteristics of a Black Brant VC boost vehicle. In Addition to a PCM telemetry data link, a video signal was transmitted from an aft viewing television camera on the payload. Command capabilities included the manual control of the attitude control system, operation of a 35mm film camera and redundant actuation of all pre-programmed payload sequencer functions. The specific functions described are generally applicable to most operations which are normally pre-programmed using on-board sequencers.

2.0 DESIGN REQUIREMENTS

System constraints for the command control console included interfacing with the telemetry ground station and the master command coder, as well as maintaining compatability with the payload sequencer logic and the attitude control system. Human factors engineering relative to panel layout and to providing pertinent data to the operator was also an important consideration. Two identical sloping panel instrument cabinets were selected and designated as attitude control system (ACS) command control console and payload command control console.

2.1 TELEMETRY DATA

Payload data was transmitted on a 250 Kbps. PCM telemetry link. Initially the digital data was to be translated directly in the command control consoles; however, a 16-channel digital to analog converter (DAC) was available in the telemetry ground station, and the analog signals were eventually selected. Coaxial connectors were mounted on the rear of the consoles to interface the 0 to +5 VDC signals directly from the DAC.

A second r-f link was devoted to the video transmitter for the television signal.

2.2 MASTER COMMAND CODER

Oklahoma State University designed the command system used to transmit PCM words within the ranging signal from the auto-tracker. The master command coder is capable of accepting a total of 32 commands from four independent remote command coders. Each remote coder is clocked and powered from the master command coder, and 8-bit serial data is generated at the source. An 8-stage static shift register (4021) was packaged in each of the two command control consoles to convert the parallel commands to a serial output. The attitude control system console and the payload console were then designated as remote command coders A and B, respectively.

2.3 COMMAND RECEIVER

The command receiver is located in the telemetry/command module and requires electrical interfaces to the forward attitude control system and the aft instrument module which houses the flight sequencer. Relays in both systems were made compatible with the driver outputs of the command receiver, including the provision for sequencer control of the payload functions.

2.4 ATTITUDE CONTROL SYSTEM (ACS)

Outputs from the attitude control system are all 0 to +5 VDC analog signals digitized by the on-board PCM encoder. Signal conditioning circuits in the command control consoles were required to translate the received signals into meaningful real-time data displays for the console operators. Initially the attitude control system is pre-programmed to maintain the predicted attitude at payload separation; ie, roll returned to uncage position, yaw to be that angle held in yaw memory, and pitch to be the predicted

flight path angle. Manual control of the attitude control system from the command control console was at the discretion of the operator, and the system was designed to revert to the pre-programmed mode in the event of a failure in the manual control. The operator also had the option of returning to the pre-programmed attitude at any time during the flight.

In addition to position and rate data, several diagnostic and status monitors from the attitude control system were displayed on the consoles.

3.0 COMMAND CONTROL CONSOLE CONFIGURATION

Console functions were divided such that one operator would have only the information necessary to operate the attitude control system. The second operator was stationed at the adjacent console to assist the attitude control operator as well as perform the required payload related functions. A television monitor was positioned directly above the consoles. Figures 3.1 and 3.2 depict the configuration of the attitude control system console and the payload console respectively. Payload attitude is controlled by the eight position joystick and the two position rotary switch on the ACS panel. The film cameras and other payload functions are initiated by momentary switches on the payload console. Relevant monitors are included on each panel. Critical functions, such as T-time, yaw limit and gas pressure are displayed on both consoles.

3.1 ACS CONSOLE COMMANDS

Eight functions were controlled from the ACS command control console:

1. ACS to rate control.
2. Nose up (Pitch +).
3. Nose down (Pitch -).
4. Nose left (Yaw +).

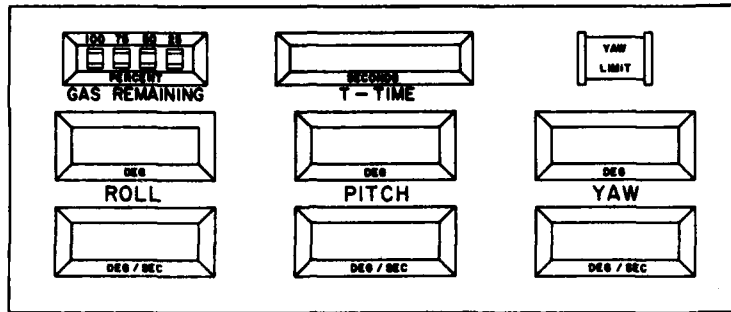

MONITOR PANEL DETAILS

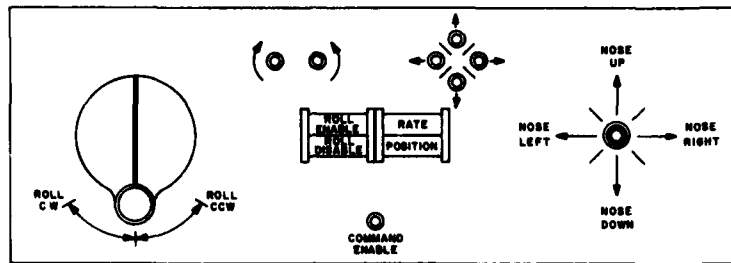

MAIN CONTROL PANEL DETAILS

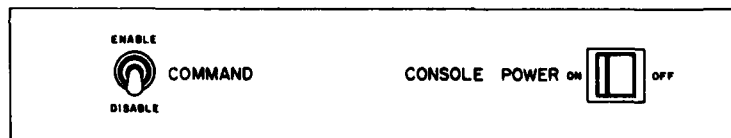

BOTTOM CONTROL PANEL DETAILS

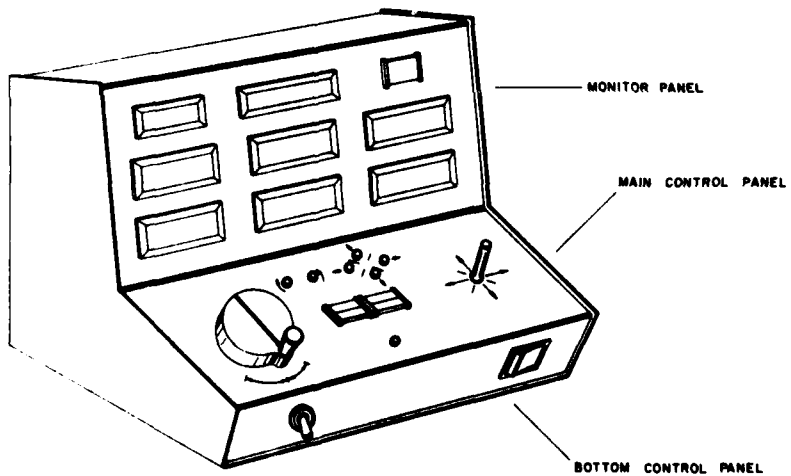

FIGURE 31 — ATTITUDE CONTROL SYSTEM (ACS) CONSOLE CONFIGURATION

5. Nose right (Yaw -).
6. Disable roll control.
7. Roll clockwise (Roll +).
8. Roll counterclockwise (Roll -).

As indicated, the ACS will remain in position and the roll will remain enabled until the operator initiates a command to assume manual control of either or both. Illuminated, latching, push button switches are used for the rate/position and the roll enable/roll disable commands.

The joystick is a center off control which actuates a single switch in the 90° directions, and will actuate two switches simultaneously in the 45° directions. A center off rotary switch was used for roll control.

3.2 ACS CONSOLE MONITORS

LED indicators (Figure 3.1, Main Control Panel) were used in conjunction with each of the six ACS command functions described in the previous section. Payload positions and ACS rates were displayed in degrees and degrees/second respectively on the monitor panel. Position limits are + or -180° for the pitch and roll axes and + or -90° for the yaw axis. Rate displays were set for a maximum of + or -5 degrees/second in pitch and yaw, and + or -90 degrees/second in roll.

The gas remaining monitor on the ACS panel was generated from the telemetry gas pressure signal. LED's were illuminated for 100%, 75%, and 50% gas remaining. When the gas reached the critical 25% level all four LED's were programmed to flash on and off at one second intervals. The 25% level was selected to alert the operator to minimize gas use in anticipation of the final maneuver to the re-entry attitude. Similarly the yaw limit indicator was set to flash if the payload yaw position monitor exceeded + or -60 degrees. Actually, the gyro is capable of + or -85 degrees in yaw, but the conservative 60° limit was selected to allow the operator sufficient reaction time.

3.3 PAYLOAD CONSOLE COMMANDS

The primary command function from the payload command control console was the operation of the manual film camera. A momentary switch on the control panel enabled the operator to actuate the control relay for the manual camera which had the same view angle as the television camera and the timer film camera. Four of the pre-programmed sequencer functions (ACS yaw hold, ACS position control, television camera on, and timer camera on) were redundantly controlled from the payload console in the event of a sequencer failure. This also provided the option of commanding the functions prior to the pre-programmed time if, for example, the trajectory was lower than predicted.

Start/stop commands for the countdown timer were also included on the payload console.

3.4 PAYLOAD CONSOLE MONITORS

All the commands discussed in Section 3.3 were controlled by illuminated, momentary, push button switches. Signals from the r-f data link illuminated the yaw hold, ACS position, and television on monitors when the function occurred in the payload independent of whether it was initiated by the sequencer or the command system. Similar monitors were used for the manual and timer controlled cameras. In addition digital displays were utilized to record the status of each camera. Counters were preset to 35 seconds (the anticipated total running time of each camera) and the remaining film time was displayed.

Five ACS telemetry functions were monitored on the payload console. The ACS operation mode indicator consisted of six LED's, which confirmed the current status of the ACS in the payload. The ACS gas monitor was calibrated directly in K psi and was generated from the same telemetry signal as the gas remaining monitor on the

ACS panel. Roll, pitch and yaw null monitors were direct reading digital panel meters.

Two critical monitors from the ACS console-yaw limit and rate/position status-were duplicated on the payload console. Displays of real-time azimuth and altitude data from the tracker were originally designed to be an integral part of the payload console; however, an existing display panel was available as part of the tracker ground station, and was used for convenience in thus application.

4.0 COMMAND CONSOLE ELECTRICAL INTERFACE

Modular, plug-in circuit boards were used in each command control console to condition the telemetry signals. Coax connectors on the rear of each console interfaced directly with the output of the DAC, and multiple pin connectors were used to interconnect the two consoles and the master command coder. Electrical block diagrams of the consoles are presented in Figures 4.1 and 4.2. All commands (8 on the ACS console and 5 on the payload console) are momentary switch closure inputs to a 4021 parallel-to-serial shift register in each console. Clocking of the shift registers and command power are provided from the master command coder. Command enable controls and monitors are included on each console as well as de-bounce circuits on the command switches.

4.1 ACS CONSOLE

As indicated on Figure 4.1, LED's were used to confirm actuation of the joystick and roll control switches. Status of the command system (rate/position and roll enable/roll disable) was monitored on the illuminated push button switches on the main control panel.

Telemetry signals were translated to display the gyro positions in degrees and the ACS rates in degrees/second on the digital meters. Figure 4.3 "Signal Conditioning Module-Type 1" defines

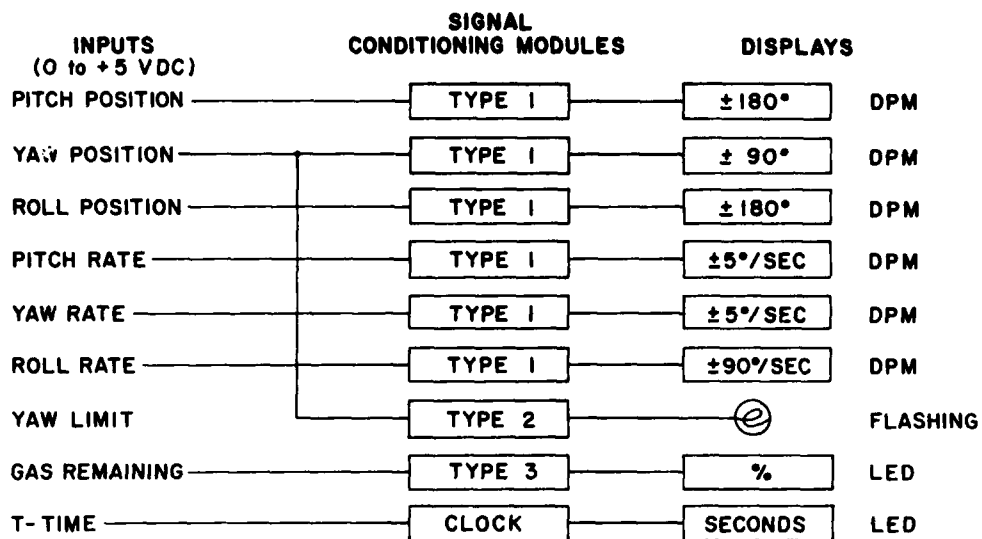

MONITORS

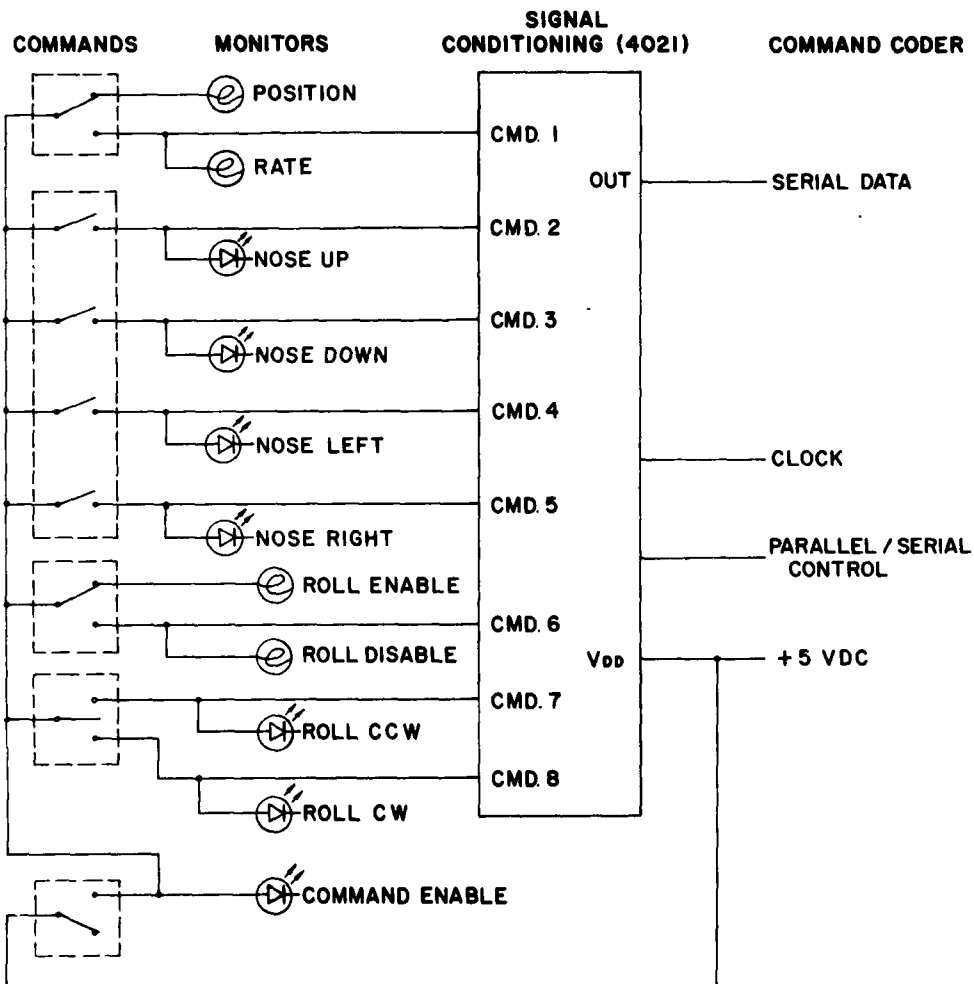

CONTROLS

FIGURE 4.1 — FUNCTIONAL BLOCK DIAGRAM
ACS CONSOLE

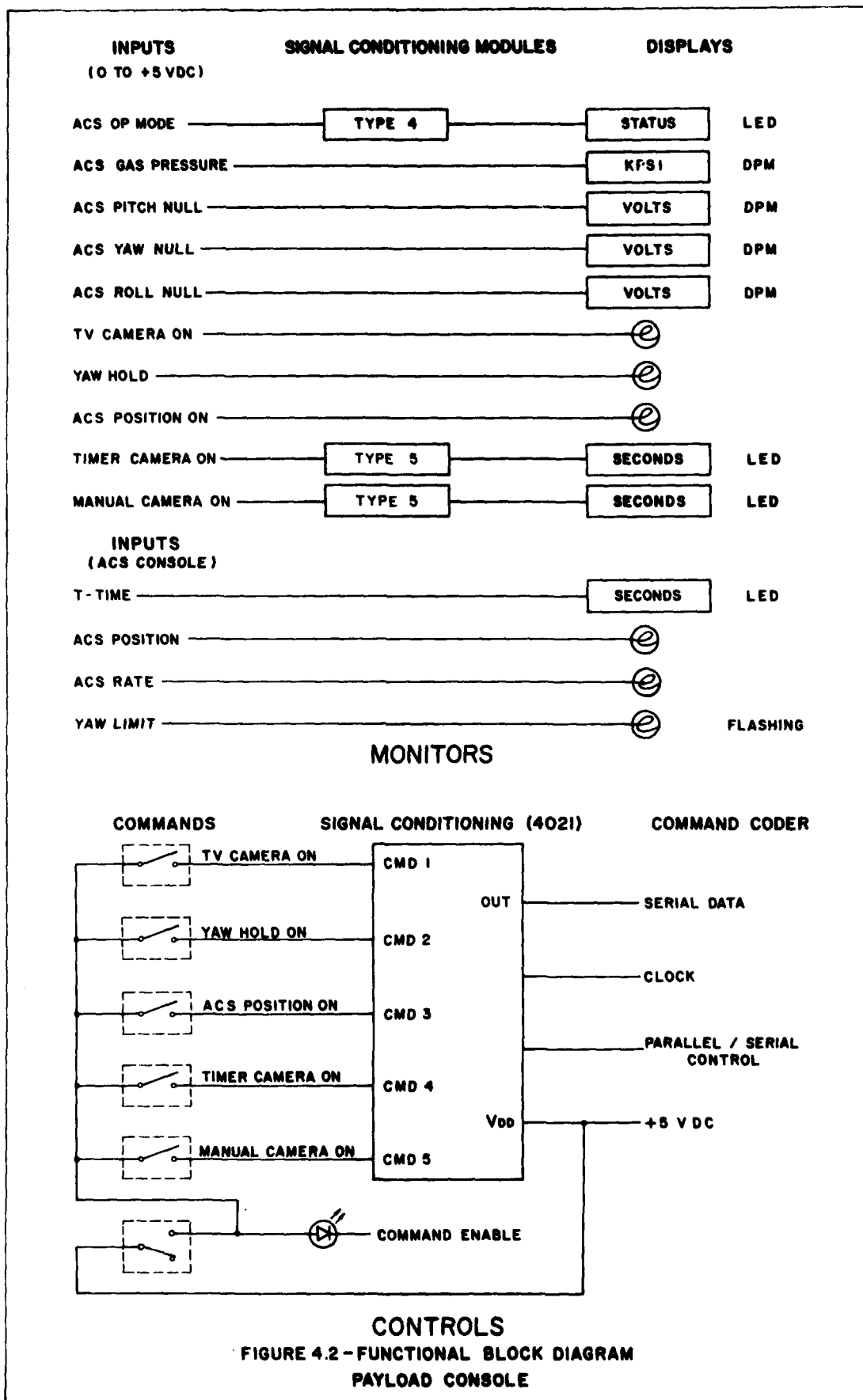

FIGURE 4.2 - FUNCTIONAL BLOCK DIAGRAM
PAYLOAD CONSOLE

the circuitry used for the position and rate signals. The first operational amplifier stage provides the proper offset for the 0 to +5 volt input signal, and the second stage introduces a scale factor. The adjustment potentiometers indicated are accessible on the rear panel of control console. Table 4.1 details the range and the voltage levels of the six type 1 and the single type 2 signal conditioning modules. The yaw limits were generated from the type 2 module, consisting of a type 1 circuit used in conjunction with voltage comparators to provide the flashing yaw limit flag at + or -60 degrees.

A type 3 signal conditioning module was used to generate the ACS gas remaining monitor from the ACS gas pressure telemetry signal. Voltage comparator circuits illuminated LED's at 100%, 75% and 50% gas remaining levels. When the gas remaining reached the critical 25% level, all 4 LED's were programmed to flash at one second intervals. Since 3K psi was considered 100% on the linear gas pressure monitor, the following switching levels were established:

| | MAXIMUM | | MINIMUM | |
|------|---------|------|---------|------|
| | PSI | VDC | PSI | VDC |
| 100% | 3,000 | 3.00 | 2,250 | 2.25 |
| 75% | 2,250 | 2.25 | 1,500 | 1.50 |
| 50% | 1,500 | 1.50 | 750 | 0.75 |
| 25% | 750 | 0.75 | 0 | 0.00 |

This monitor was intended as a quick-look indicator for the ACS console operator. Intermediate gas level readings were available on the direct reading meter on the payload command control console.

4.2 PAYLOAD CONSOLE

The type 4 signal conditioning module on Figure 4.2, consisted of voltage comparators programmed to illuminate three of the six LED's in the ACS operation display, on the payload command control console. Table 4.2 defines the telemetry signal input levels for the eight possible status combinations. Direct reading digital volmeters (0 to +5 VDC) were used for the ACS gas pressure

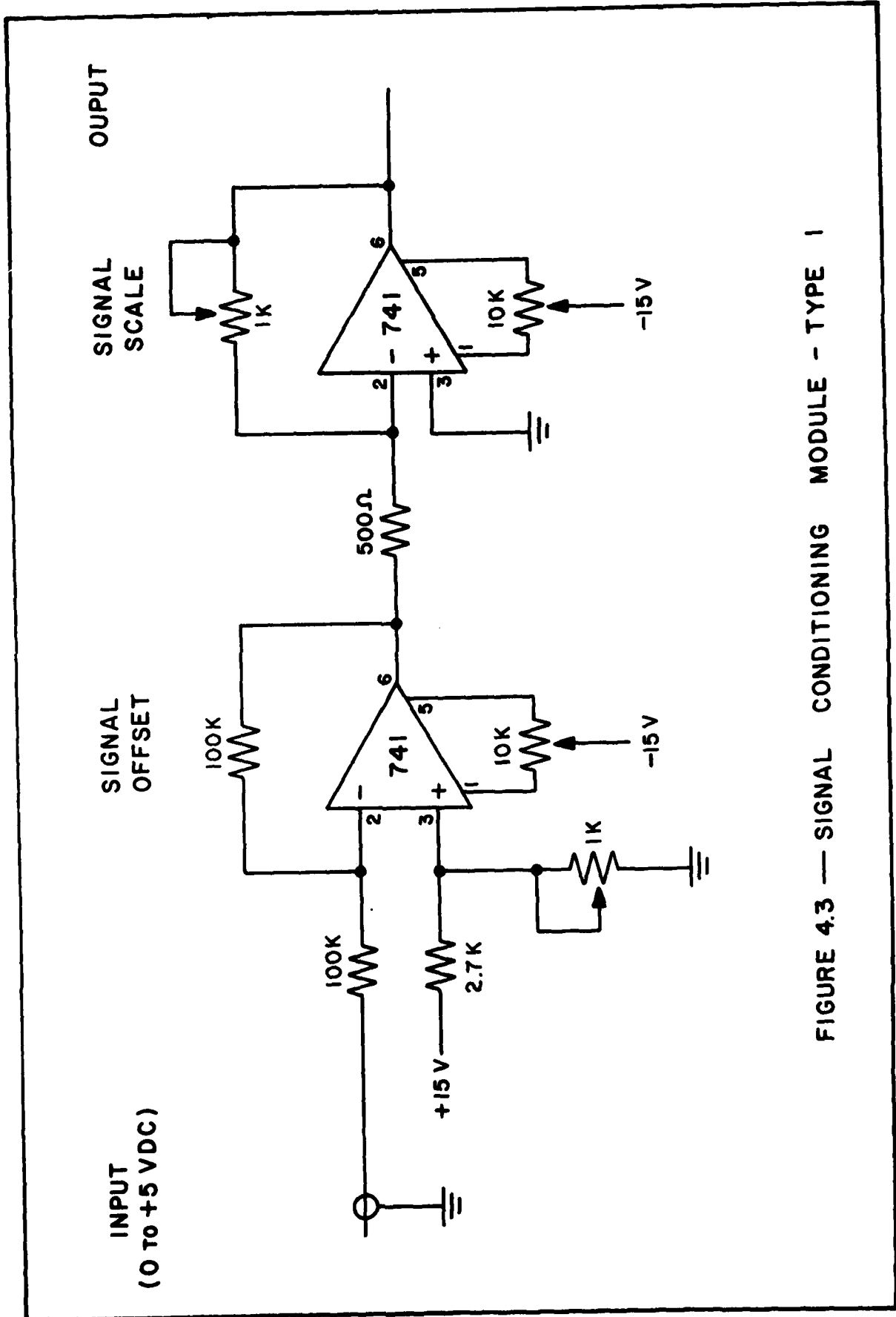

FIGURE 4.3 — SIGNAL CONDITIONING MODULE - TYPE 1

| | RANGE | SIGNAL (VDC) | OFFSET (VDC) | SCALE (VDC) | DISPLAY |
|--------------------------------|-------|-----------------|-----------------|----------------|---------|
| <u>Pitch Position (Type 1)</u> | | | | | |
| (13.9 mv/deg) | +180 | +5.0 | +2.5 | +1.8 | +180 |
| | 0 | +2.5 | 0 | 0 | 0 |
| | -180 | 0 | -2.5 | -1.8 | -180 |
| <u>Roll Position (Type 1)</u> | | | | | |
| (13.9 mv/deg) | +180 | +5.0 | +2.5 | +1.8 | +180 |
| | 0 | +2.5 | 0 | 0 | 0 |
| | -180 | 0 | -2.5 | -1.8 | -180 |
| <u>Yaw Position (Type 1)</u> | | | | | |
| (27.8 mv/deg) | +90 | +5.0 | +2.5 | +0.9 | +90 |
| | 0 | +2.5 | 0 | 0 | 0 |
| | -90 | 0 | -2.5 | -0.9 | -90 |
| <u>Yaw Limit (Type 2)</u> | | | | | |
| (Flag) | +60 | +4.17 | +1.66 | +0.6 | +60 |
| | 0 | +2.5 | 0 | 0 | 0 |
| | -60 | +0.83 | -1.66 | -0.6 | -60 |
| <u>Pitch Rate (Type 1)</u> | | | | | |
| (500 mv/deg/sec) | +5 | +5.0 | +2.5 | +0.5 | +5.0 |
| | 0 | +2.5 | 0 | 0 | 0 |
| | -5 | 0 | -2.5 | -0.5 | -5.0 |
| <u>Yaw Rate (Type 1)</u> | | | | | |
| (500 mv/deg/sec) | +5 | +5.0 | +2.5 | +0.5 | +5.0 |
| | 0 | +2.5 | 0 | 0 | 0 |
| | -5 | 0 | -2.5 | -0.5 | -5.0 |
| <u>Roll Rate (Type 1)</u> | | | | | |
| (27.8 mv/deg/sec) | +90 | +5.0 | +2.5 | +0.9 | +90 |
| | 0 | +2.5 | 0 | 0 | 0 |
| | -90 | 0 | -2.5 | -0.9 | -90 |

TABLE 4.1 - ACS POSITION AND RATE MONITORS

| <u>SIGNAL INPUT (VDC)</u> | <u>ROLL STATUS</u> | <u>P/Y STATUS</u> | <u>ACS STATUS</u> |
|-------------------------------|--------------------|-------------------|-------------------|
| 5.00 | Position | Position | OFF |
| 4.37 | Position | Position | ON |
| 4.08 | Position | Rate | OFF |
| 3.71 | Position | Rate | ON |
| 3.53 | Rate | Position | OFF |
| 3.28 | Rate | Position | ON |
| 3.15 | Rate | Rate | OFF |
| 2.97 | Rate | Rate | ON |

TABLE 4.2 - ACS OPERATION MODE MONITOR

(1 VDC = 1K psi) and the three gyro nulls.

Command confirmation of sequencer functions (yaw hold, ACS position, and television) to the illuminated switches were generated from the received telemetry signals. The timer camera and manual camera monitors were wired to type 5 signal conditioning modules, where they were gated with the clock signal to enable counters. Outputs from the counters controlled the preset remaining film displays. Inputs to the remaining monitors on Figure 4.2 (T-time, ACS position, ACS rate, and yaw limit) are generated from the ACS command control console and displayed redundantly on the payload console.

5.0 TESTING

The two consoles defined were specifically designed to support AFGL payload Number A18.805. Integration and air-bearing tests were conducted at Space Vector Corporation, Northridge, California, and the Black Brant VC vehicle was launched from White Sands Missile Range, New Mexico.

5.1 INTEGRATION TESTS

Functional checks of the command control consoles were completed, and simulated input signals were used to calibrate the displays and check the adjustment limits of the signal conditioning module potentiometers. Compatibility with the master command coder and the 16 channel DAC was confirmed during payload integration checks. Telemetry signals from the payload were processed through the ground station and verified on the command control consoles. The payload was then installed on the air-bearing fixture.

5.2 AIR-BEARING TESTS

Initially the 13 commands from the command control consoles were actuated sequentially and verified at the payload. A visual target was then set-up in the field-of-view of the television camera

and the ACS console operator controlled the payload on the air-bearing, aided by the television monitor and the displays on the console. The stationary array in the test area was then expanded to five targets at specified coordinates. Three air-bearing runs of approximately six minutes each were conducted tracing a predetermined path between the five targets. Telemetry data was recorded during each test to confirm the predicted positions, rates, and nozzle fire sequence. Later, a second target panel was added and seven more air-bearing runs were successfully completed, including slewing to predetermined pitch roll and yaw locations using only the command control console monitors.

Finally, a white target was moved randomly along a dark background and the console operators were able to track the target successfully. Target sizes were sequentially reduced to simulate booster distances of 25, 60, 75, and 100 feet from the aft end of the payload. Telemetry records during the air-bearing runs confirmed that the ACS and the payload functions responded appropriately to the command system.

5.3 LAUNCH RESULTS

Payload A18.805 was successfully launched on 7 August 1979. Separation of the payload from the boost vehicle occurred, as predicted, at T+66 seconds and was observed on the real-time television monitor in the blockhouse. All sequencer actuated payload functions occurred as programmed, requiring no action from the payload command console operator other than control of the manual film camera. The flight sequence is presented in Table 5.1

Post-flight data indicate that the booster separated approximately 19-feet from the payload at an average separation velocity of 1.1 feet/second. Post burnout thrust then caused the booster to accelerate and overtake the payload in approximately 30 seconds; during which time the ACS console operator took manual control of the payload. Since the acceleration of the spent booster

| TIME (SECONDS) | ALTITUDE (KILOMETERS) | EVENT |
|-------------------|--------------------------|----------------------------|
| T + 32 | 28 | Booster Burnout |
| T + 36 | 36 | Television Camera On |
| T + 40 | 44 | Yaw Hold On |
| T + 50 | 62 | Despin |
| T + 60 | 79 | Nosecone Eject |
| T + 65 | 87 | Timer Camera On |
| T + 66 | 89 | Payload/Vehicle Separation |
| | | ACS Position On |
| T + 235 | 219 | Payload Apogee |
| T + 560 | 6.1 | Recovery Sequence |
| T + 1001 | | Payload Impact |

TABLE 5.1 - A18.805 FLIGHT SEQUENCE

far exceeded pre-flight predictions the ACS was not capable of tracking the booster after it passed alongside the payload. Noise on the received telemetry signal in the blockhouse during the early portion of the flight compounded the problem; however, the console operator was able to exercise the control system and orient the payload for a successful recovery sequence. The television signal was solid throughout the flight.

6.0 SUMMARY

The design concepts proved feasible and the command control console performed well in this application. Interfacing with the existing ground support equipment and flight hardware presented no problems. Minimizing the monitor functions on the ACS console and duplicating the critical ACS functions on the payload console was advantageous, and allowed the ACS operator to concentrate primarily on the television screen.

Considerations for future systems should include the option of multiple rates for the control system and direct interfacing of the digital PCM data, eliminating the requirement for a multi-channel DAC and the potentiometer adjustments on the operational amplifier signal conditioning circuits.

Appendix A

Related Documents and Contracts

The following internal reports include specific component information and event sequences for payload A18.805:

| | |
|---------|--------------------------------|
| NU109-2 | Telemetry and Calibration Data |
| NU109-5 | Payload Data |
| NU109-6 | Post Flight Data |

Previous Publications:

Scientific Report No. 1: Raimundas Sukys,
"MSMP Timer Testing and Programming
Instrument," 1 May 1977.

Scientific Report No. 2: Richard L. Morin,
"Motor Drive Systems for Sounding Rocket
Payloads," October 1978

Previous Contracts:

| | |
|------------------|----------------------------------|
| F19628-67-C-0223 | 1 April 1967 to 28 February 1970 |
| F19628-70-C-0194 | 1 March 1970 to 28 February 1973 |
| F19628-73-C-0152 | 1 March 1973 to 31 May 1976 |
| F19628-76-C-0152 | 1 May 1976 to present |

Appendix B

Personnel

The following members of the Electronics Research Laboratory staff contributed to the work reporter.

| | |
|-----------------------|------------------------------|
| Lawrence J. O'Connor, | Principal Investigator |
| Richard L. Morin, | Research Associate, Engineer |
| Francis J. Bonanno, | Mechanical Designer |
| Roger C. Eng, | Mechanical Designer |
| Jonathan L. Harris, | Electronic Technician |
| Charles B. Sweeney, | Electronic Technician |
| Frederick J. Tracy | Electronic Technician |