

2

→ This study is **FOREWORD**

In August 1979, DARCOM performed a quantitative analysis of military and civilian manpower trends over time with the goal of identifying minimum (baseline) requirements to achieve peacetime efficiency and to establish authoritatively a level from which surge/mobilization demands can be accommodated. That analysis was entitled the DARCOM Baseline Study.

The Baseline Study was well received at Department of the Army and Department of Defense levels. It has been cited as a most comprehensive undertaking which has been used as a valuable management tool, and which should be updated to reflect the current DARCOM profile of requirements contrasted to resources. Accordingly, this issue of the Baseline Study is presented.

DTIC
ELECTE
MAY 8 1980
S D
C

This document has been approved for public release and sale; its distribution is unlimited.

TABLE OF CONTENTS

I. Force Structure Trends—Other Major Events During DARCOM Drawdown	1
II. Manpower Cuts—Workload Trends—Mission Impacts— Log Readiness	22
III. Manpower Cuts—Workload Trends—Mission Impacts— Development	48
IV. Baseline Manpower Requirement	76

Accession For	
NTIS Grant	
DDC TAB	
Unannounced	
Justification <i>[Signature]</i>	
By <i>[Signature]</i>	
Distribution/	
Availability Codes	
Dist	Avail and/or special
<i>A</i>	

DARCOM BASELINE STUDY

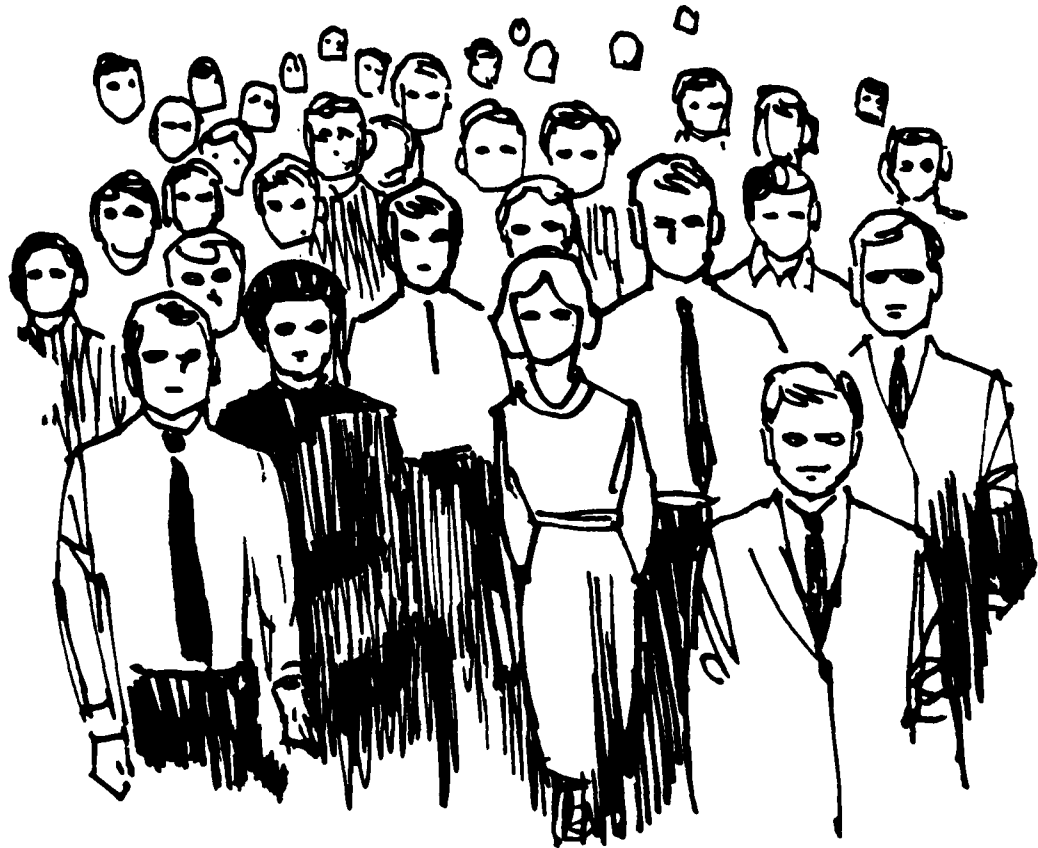

I-1

v

DARCOM BASELINE STUDY

The study findings are presented in four parts as shown on Chart I-2.

- Changes to the force structure and other events affecting DARCOM during the manpower draw-down.
- Impact on the logistics readiness mission.
- Impact on the development mission.
- Definition and rationale for DARCOM's baseline manpower requirement.

DARCOM BASELINE STUDY

- I. FORCE STRUCTURE TRENDS -- OTHER MAJOR EVENTS DURING DARCOM DRAWDOWN.**
- II. MANPOWER CUTS -- WORKLOAD TRENDS - MISSION IMPACTS --- LOG READINESS.**
- III. MANPOWER CUTS -- WORKLOAD TRENDS - MISSION IMPACTS --- DEVELOPMENT.**
- IV. BASELINE MANPOWER REQUIREMENT.**

I-2

First we will trace DARCOM's strength since the Technical Services were abolished in 1962.

DARCOM TOTAL STRENGTH AUTHORIZED

Chart I-3 depicts the steadily declining trend in the AMC/DARCOM total strength since 1962.

From the peak of the Vietnam War, the DARCOM total authorized strength has been reduced from 183,000 personnel to the current low of 117,391.* This strength is programmed to be further reduced to 112,805 by FY 80.

The bottom line shows the trend in DARCOM's military strength which had a high of 22,300 in FY 62 to a current strength of 10,571. FY 80 is projected at 10,267.

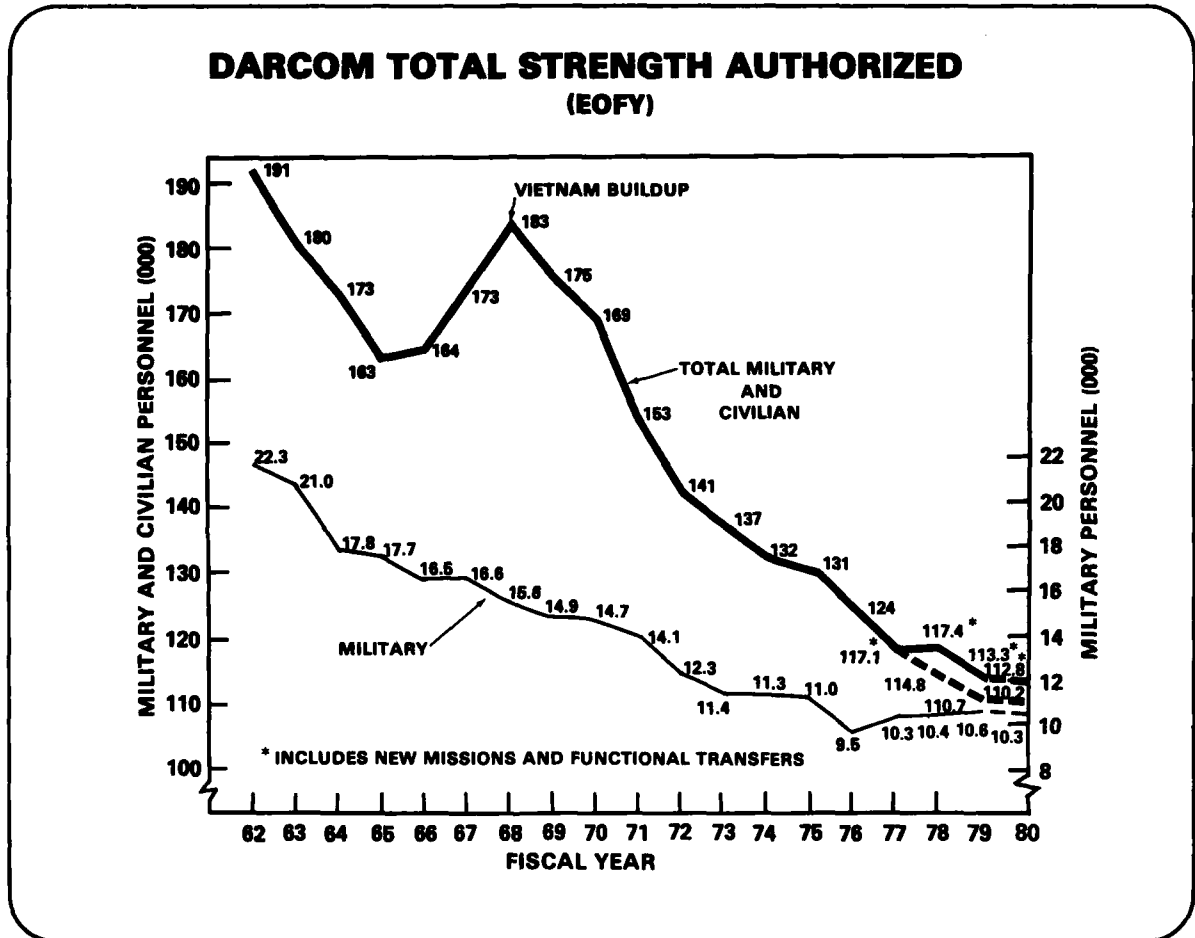

I-3

*The broken line from FY 77 to FY 78 indicates the real drawdown in strength. The solid line above it for the same period results from an input of spaces following the transfer to the Army of responsibility such as Single Manager for Conventional Ammunition.

Next we examine the relationship of total uniformed, active Army strength to total DARCOM strength—in doing so, we use regression analysis as our tool.

DARCOM STRENGTH vs. ARMY STRENGTH

Our analysis (Chart I-4) reveals a very high coefficient of correlation ($R^2 = .93$) between DARCOM civilian strength and the total active Army between FY 68 and FY 74 thus confirming the strength of the relationship. Note how the data points cluster closely around the regression line.

Beginning in FY 75 the Army stabilized its authorized strength at approximately 785,000 men while DARCOM's authorized strength continued to reduce. The reductions in those five years equate to 11.3% thereby terminating the relationship between the two variables.

This notion will be pursued in greater detail throughout this study.

DARCOM STRENGTH VS ARMY STRENGTH

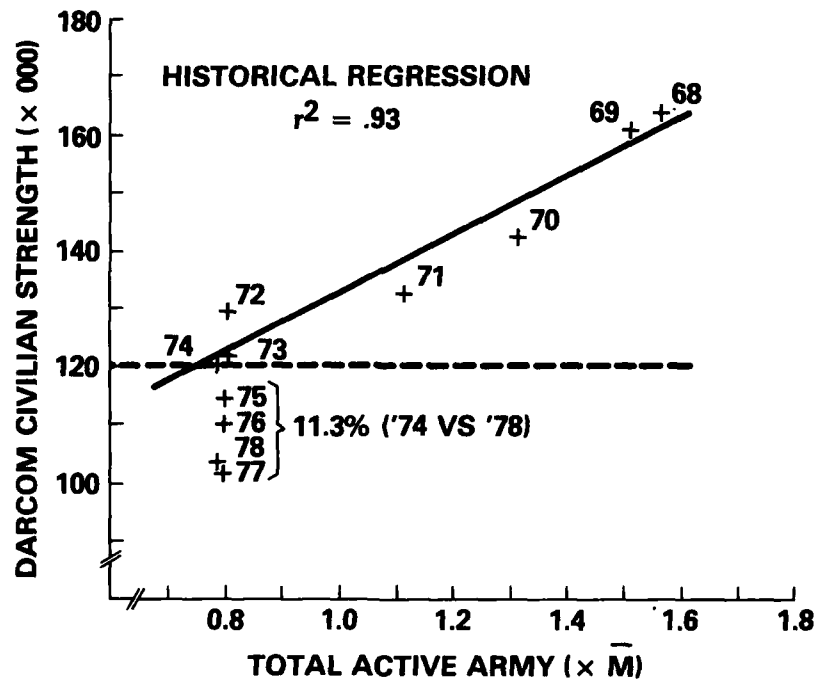

I-4

Other major events were occurring during the period of FY 74-78 which merit examination (Chart I-5).

OTHER MAJOR EVENTS DURING DARCOM DRAWDOWN

First, the Army shifted from 13 to 16 divisions. This action not only placed more equipment in the field, but changed the force mix by exchanging support soldiers for combat arms soldiers.

Next, the Army moved to heavier divisions as mech divisions were substituted for light divisions, thus increasing equipment density.

The Security Assistance Program has also increased which continues support requirements for older systems no longer in the U.S. Army inventory.

These and others listed have had a significant impact on DARCOM. Some are discussed in more detail on succeeding charts.

OTHER MAJOR EVENTS DURING DARCOM DRAWDOWN

- 1. 13-16 DIVISIONS**
- 2. MOVE TOWARD HEAVIER DIVISIONS**
- 3. INCREASE IN DENSITY OF EQUIPMENT**
- 4. INCREASE IN WEAPON SYSTEM SOPHISTICATION**
- 5. INCREASE IN SECURITY ASSISTANCE BUSINESS**
- 6. DIRECT SUPPORT SYSTEM**
- 7. OVERSEAS DEPOTS CLOSED**
- 8. AREA ORIENTED DEPOTS**
- 9. SINGLE MANAGER FOR CONVENTIONAL AMMUNITION**
- 10. NEW MISSIONS**
- 11. MANDATED PROGRAMS**
- 12. SYSTEMS SCHEDULED FOR FIELDING DURING THE NEXT FIVE YEARS**

TYPE DIVISION FORCE

The make up of the 13 active divisions in FY 74 is shown on Chart I-6. The FY 78 Army has two additional mechanized infantry divisions, and will have two more in FY 84.

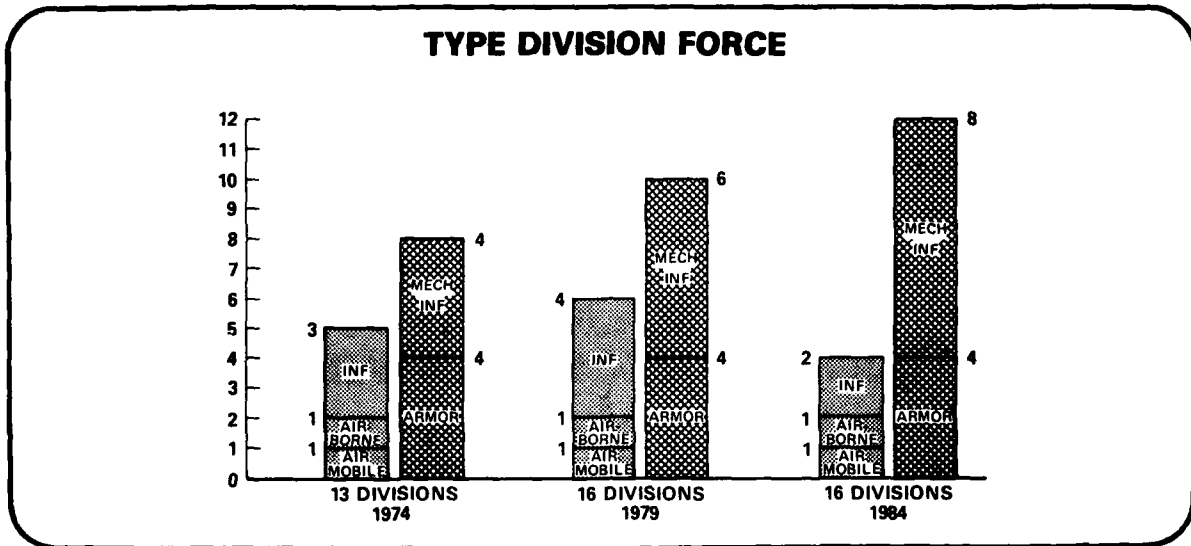

I-6

U.S. ARMY FORCE STRUCTURE TRENDS—GROUND COMBAT FORCES (BNS)

Chart I-7 shows the change in the ratio of non-mechanized infantry battalions to mech infantry battalions during the period 1966-84. While non-mech battalions decline from 40.5% to a low of 22.9%, mech battalions increase correspondingly to a high of 77.1% by 1984.

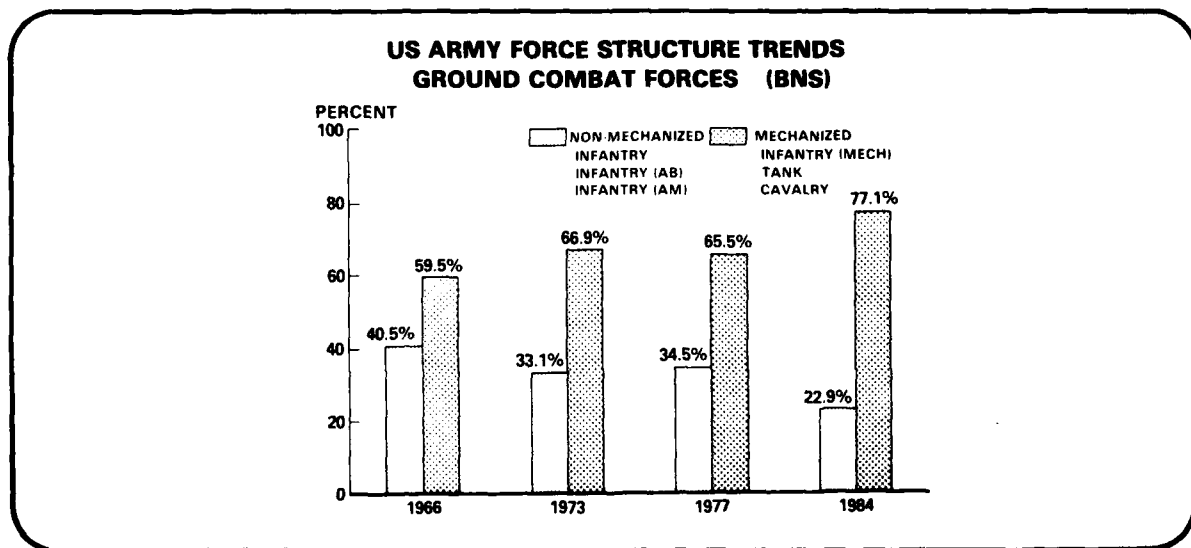

I-7

U.S. ARMY FORCE STRUCTURE TRENDS— FIELD ARTILLERY FORCES (BNS)

The same trends (Chart I-8) exist for our artillery forces. Towed artillery battalions are declining while SP battalions are increasing.

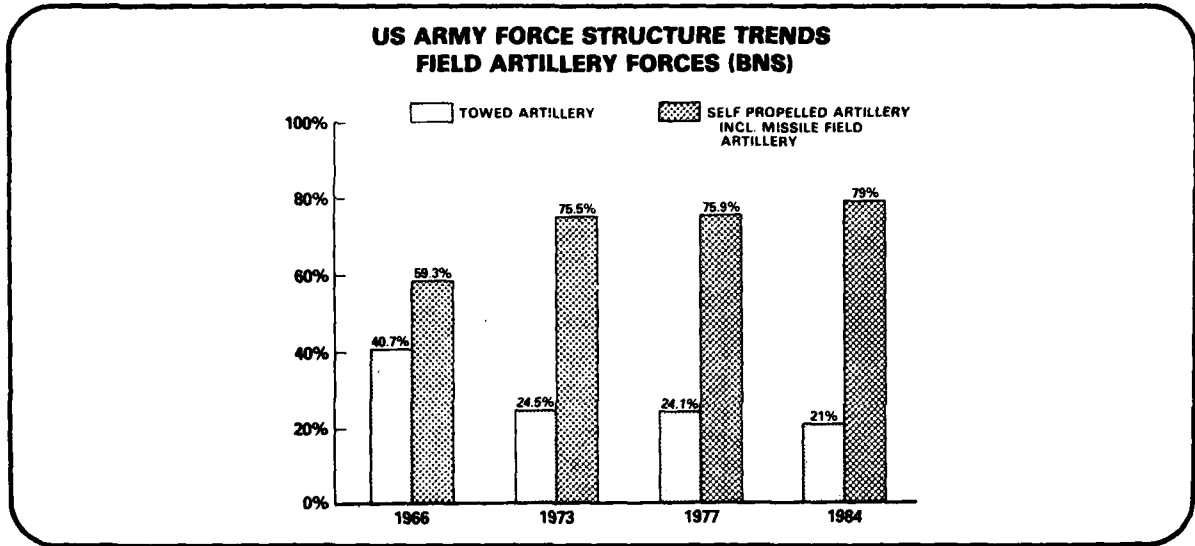

I-8

U.S. ARMY FORCE STRUCTURE TRENDS ACTIVE ARMY AVIATION (BNS)

A sharp increase in aviation battalions is also programmed (Chart I-9).

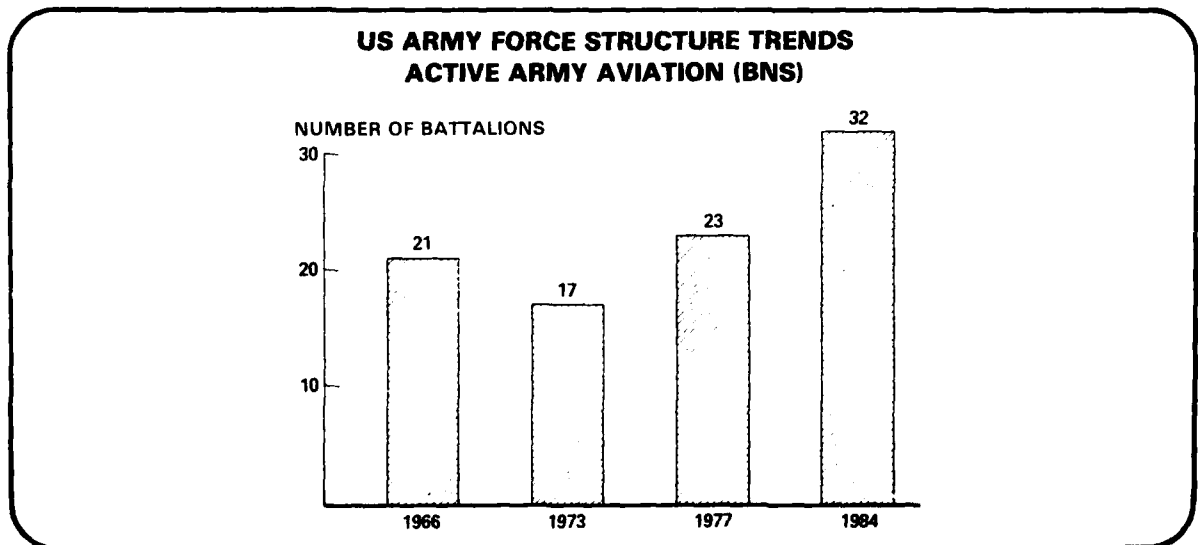

I-9

VEHICLE DENSITY BY TYPE BATTALION

Because of the force changes just described, there is an understandable exchange between wheeled and tracked vehicles in the divisions, and an overall increase in the density of aircraft equipment as aviation battalions expand (Chart I-10).

VEHICLE DENSITY BY TYPE BATTALION

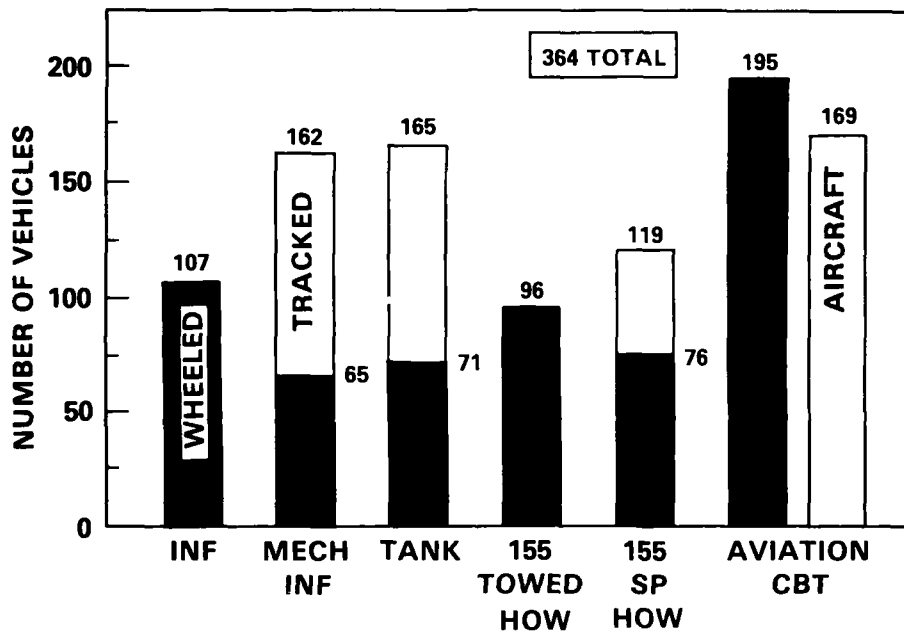

I-10

VEHICULAR ASL/REPAIR PARTS BY TYPE BATTALION

The equipment exchanges displayed on (Chart I-10) result in a significant upward adjustment to Authorized Stockage Lists [ASL] (Chart I-11).

As the Army Force moves from light infantry to mech infantry, the number of line items stocked by a battalion will increase from 365 to 622. Total items stocked (density) will increase from 1,131 to 2,953. Dollar values show a corresponding threefold increase.

A similar trend obtains when we move from 155 towed artillery to 155 SP.

Simply stated, this shift creates greater demands on the retail and wholesale logistics systems.

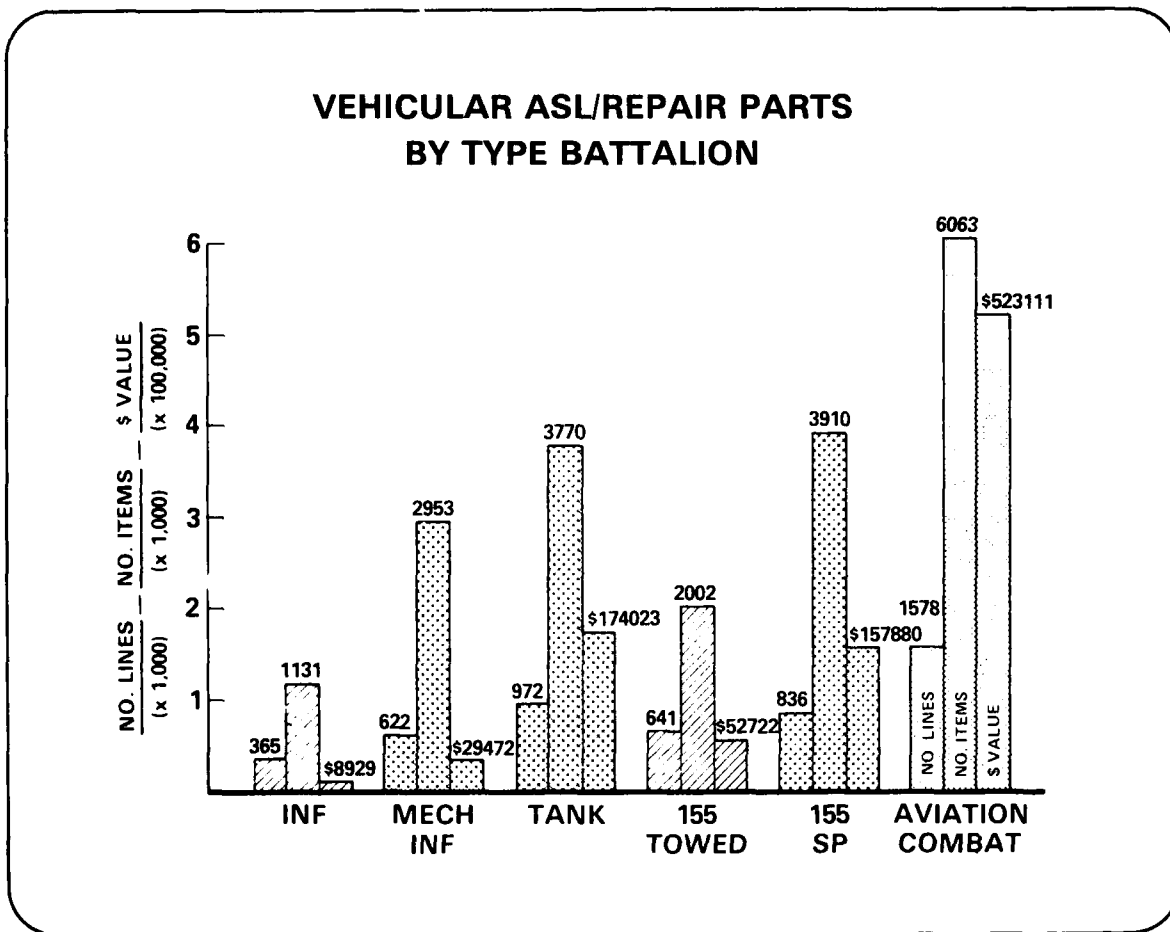

I-11

At the same time that we noted the force structure shifts, we identified an expansion of the product mix within our materiel commodities. As an example, we'll view the expansion of the number of tank models (diesel engines) from 1968-1981.

MEDIUM TANK SERIES

As we've upgraded our M48 series for our National Guard and foreign customers, the M60 series has continued to undergo modification and product improvement—it will remain a prime battle tank supplementing the XM1 in the 80's (Chart I-12).

Similar conditions are present for helicopters, APC's, ammunition, missiles, weapons, and communications equipment as the cost of new systems precludes 100% across the board replacement, thus necessitating a hi-low mix.

DARCOM must continue to provide logistics support to old as well as new systems across all commodity lines. As a consequence, line items managed and requisitions received will continue to expand as a function of time. This topic will be revisited later in this analysis.

MEDIUM TANK SERIES

NUMBER OF MODELS

<u>1968</u>	<u>1978</u>	<u>1981</u>
M48A3	M48A3	M48A3
M60	M48A5	M48A5
M60A1	M60	M60
	M60A1	M60A1
	M60A2	M60A2
	M60A3	M60A3
		XM-1/105 mm
		XM-1/120 mm

SECURITY ASSISTANCE BUSINESS

Chart I-13 displays the cumulative increase in security assistance business since FY 72. The materiel sold in FY 72 must continue to be supported by our logistics system—each succeeding year adds additional workload to DARCOM materiel readiness activities.

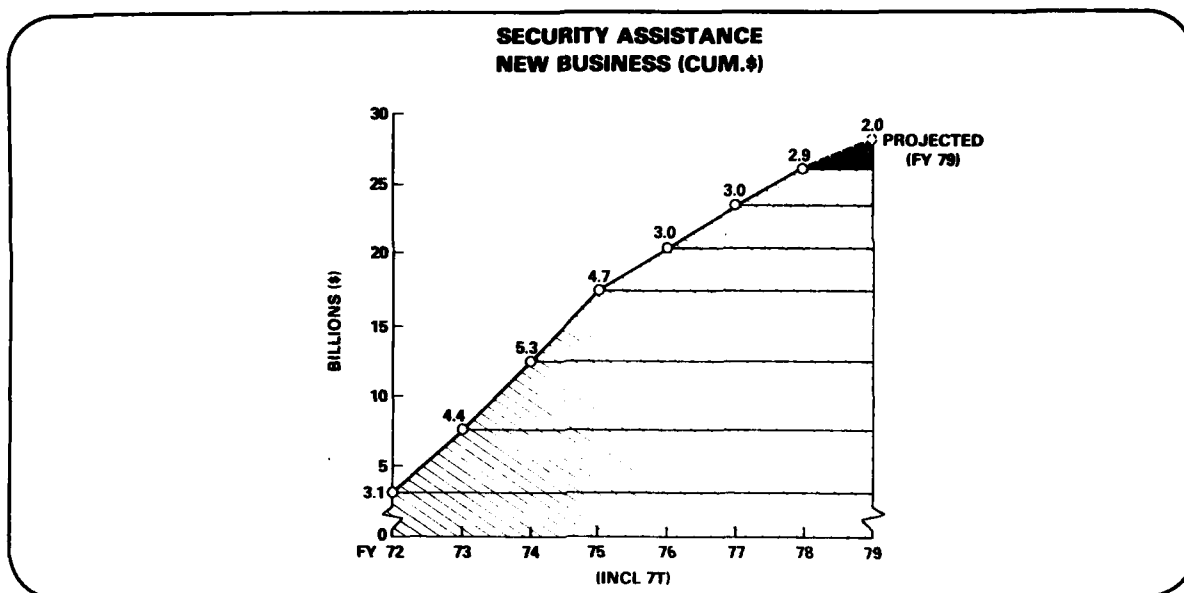

I-13

Security Assistance materiel deliveries including logistics support packages are made to friendly nations who rely upon the Army for replenishment of repair parts. Chart I-13A shows total Security Assistance requisitions processed by DARCOM since FY 74, and also, those requisitions as a percent of total DARCOM requisitions processed. Support to friendly nations who bought older Army materiel contributes to the fact that DARCOM must retain active repair parts for many systems which otherwise would have been phased out.

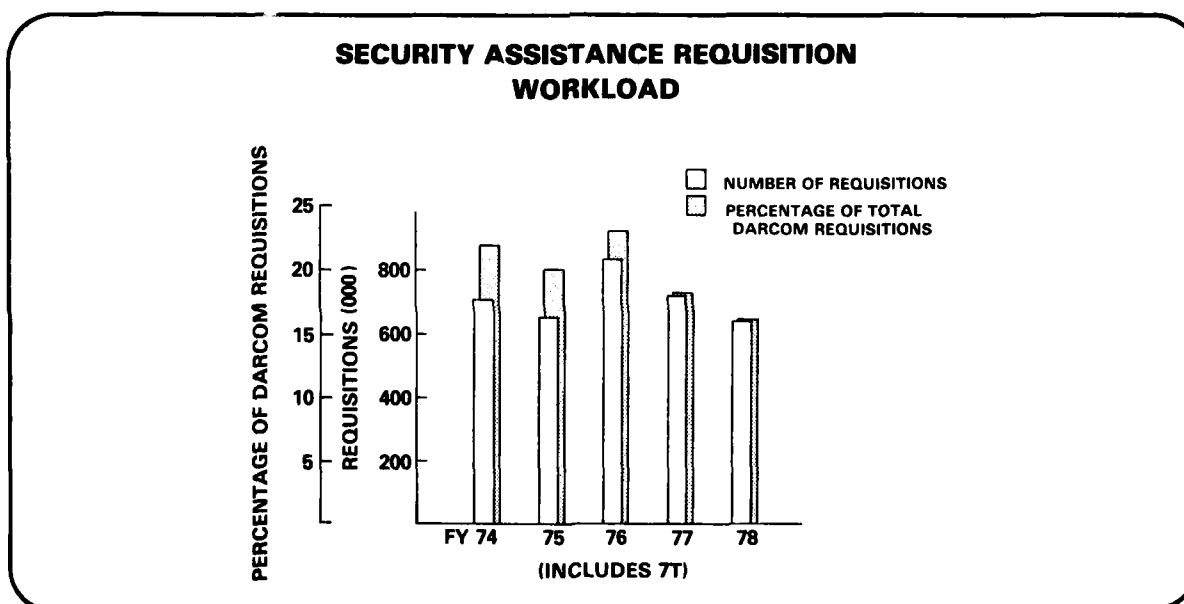

I-13A

DIRECT SUPPORT SYSTEM

Prior to the establishment of the Direct Support System (DSS), requisitions flowed from overseas GSU/DSU's to the theater Inventory Control Center (ICC) which directed the fill from overseas depots. Replenishment requisitions were directed to the CONUS depot where the requested materiel was shipped by bulk container to the overseas depot (Chart I-14).

Order ship time in pre-DSS days required 135 days.

With the DSS, as currently configured, (Chart I-14A), requisitions flow directly from the corps to the DARCOM NICP's which direct consolidated shipments from one of the Area Oriented Depots directly to the GSU/DSU. Order ship time has been reduced from 135 to 58 days for the surface mode and from 60 to 32 days for the air line of communication (ALOC).

A similar arrangement holds for CONUS organizations as shown on the charts.

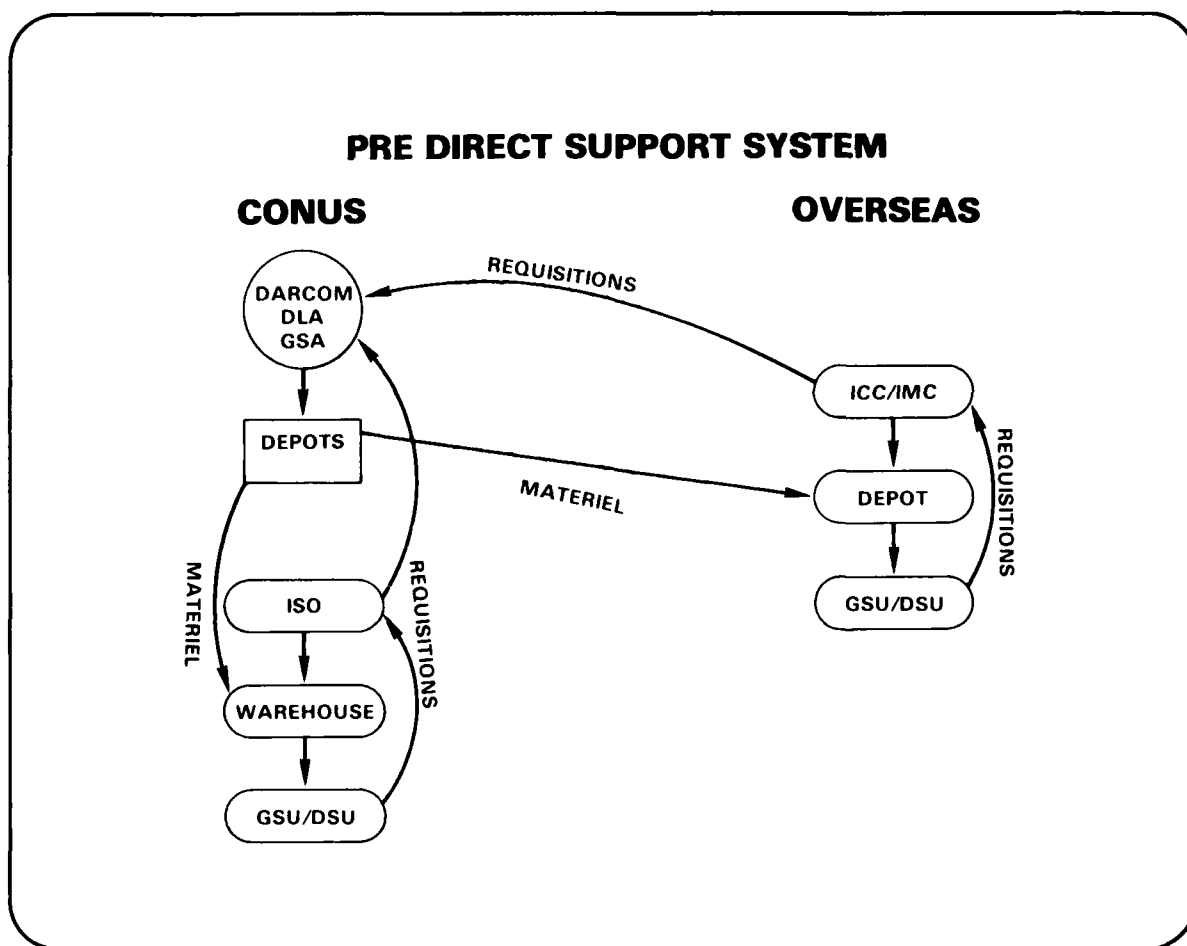

I-14

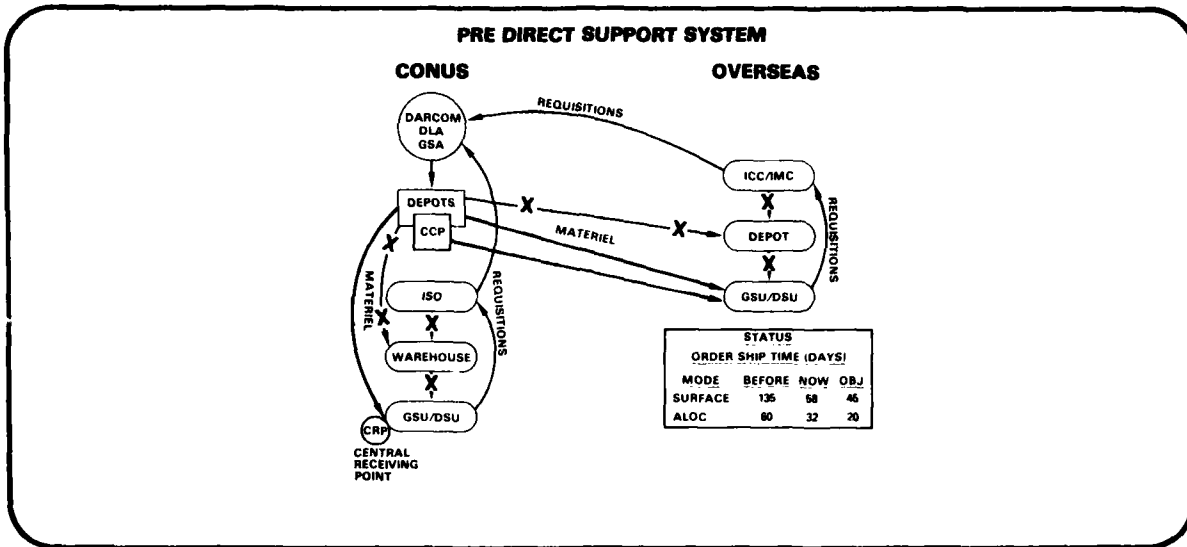

I-14A

OVERSEAS DEPOTS CLOSED IN 70'S

At the same time DSS was implemented, the overseas depots were closed (Chart I-15). The closure of these depots caused a very significant shift in supply workload to (and more reliance on) the CONUS base.

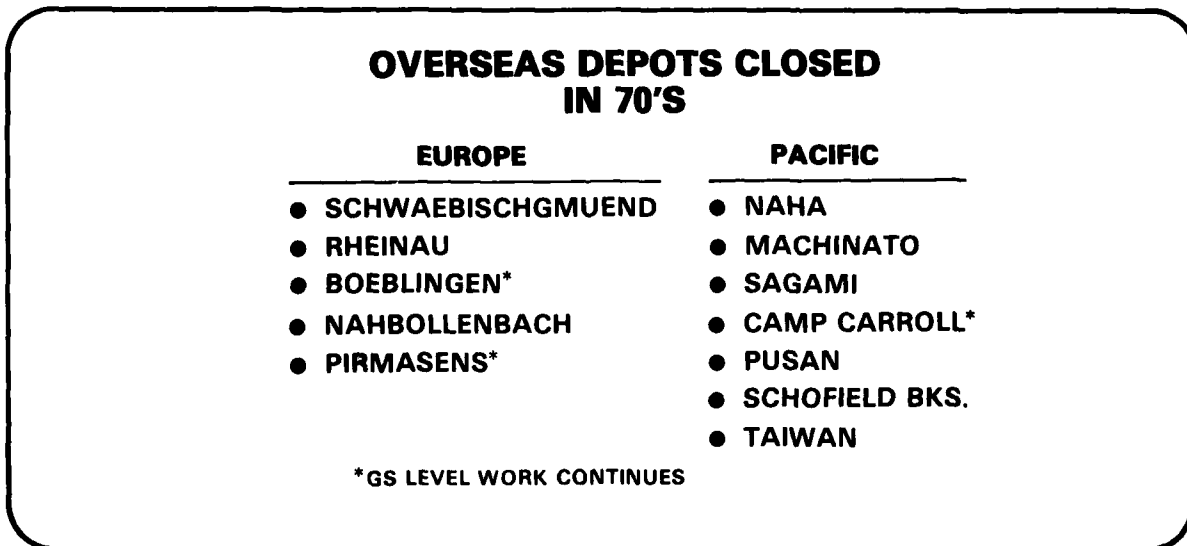

I-15

AREA ORIENTED DEPOTS

As an associated move to more efficiency, Area Oriented Depots (AOD) were established for Class IX and certain consummable DLA items. The AOD are Sharpe, Red River, and New Cumberland Army Depots (Chart I-16).

Thus, DARCOM realigned its distribution mission to assume responsibilities previously assigned to the overseas depots and to better implement DSS.

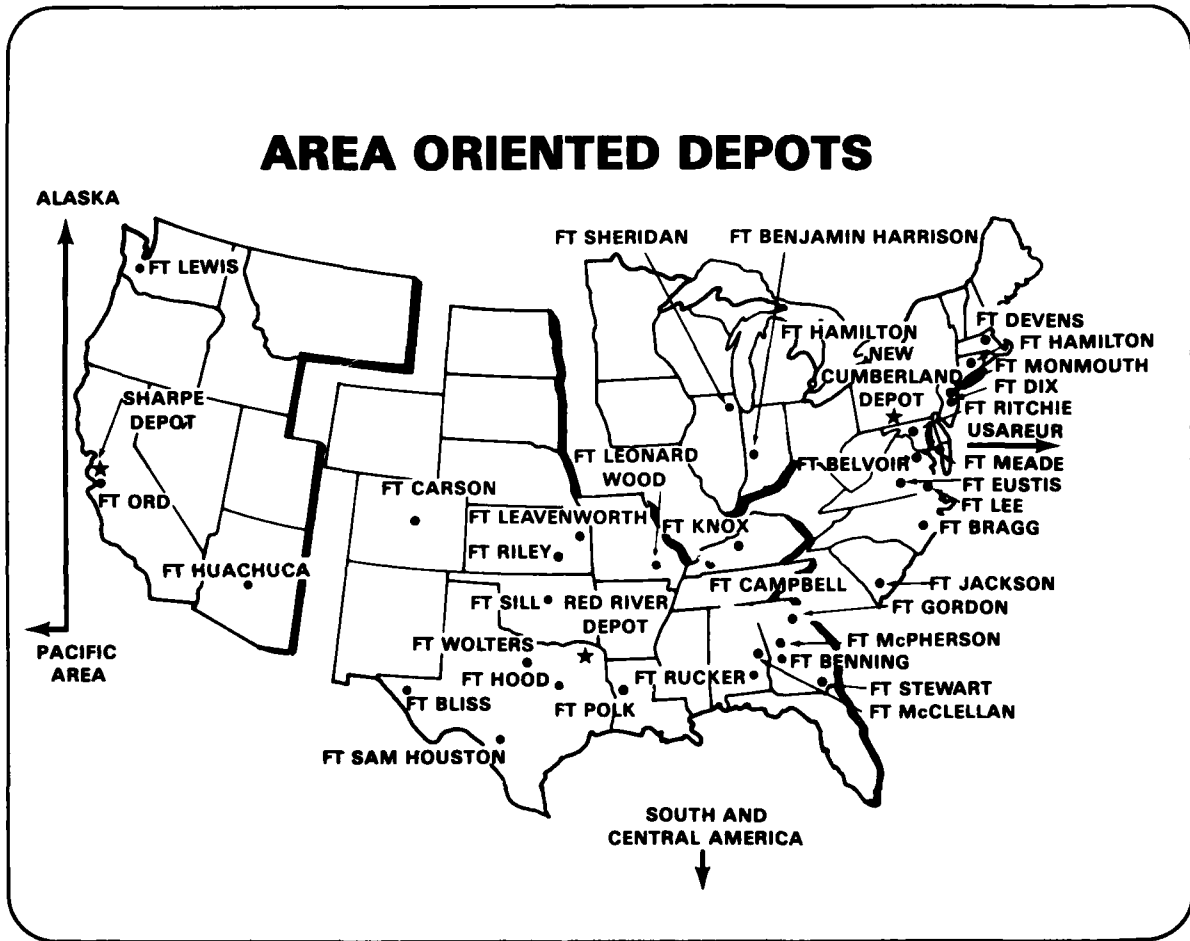

I-16

DECLINE IN WEIGHT PER REQUISITION/REQUISITIONS TREND

As might be expected, a dramatic drop occurred in the weight per requisition filled between the period FY 68 to the present time (Chart I-17). In FY 68, the average shipment weighed roughly 100 pounds. As DSS came on stream, DARCOM shipped more packages of smaller quantities. The weight per requisition filled now stands at roughly 61 pounds, and is projected to continue to decrease, then stabilize at around 55 pounds by FY 80. This is significant in that it requires more depot manhours to pick, pack and ship smaller quantities of items for increasing numbers of customers than was required in previous years when bulk packaging applied.

As evidence of this, requisitions received since DSS (1974) are increasing at a rate which DARCOM has not experienced since the Vietnam era. This results from DARCOM direct servicing 500 customers rather than 50 in the pre-DSS days.

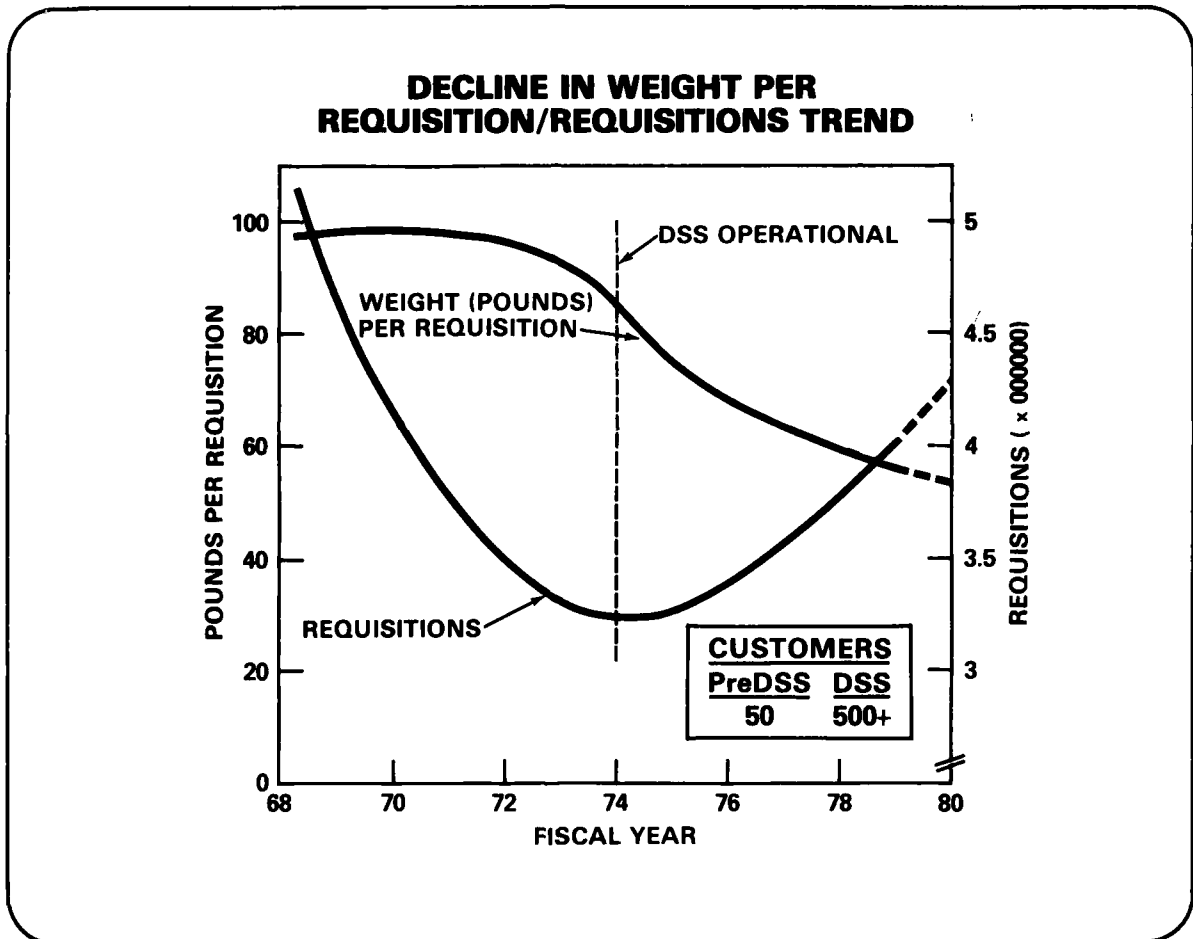

I-17

SUMMARY OF DSS-EUROPE BENEFITS

DSS has provided benefits to the Army as shown on Chart I-18. The non-recurring benefits in USAREUR alone amounted to more than 127 million dollars while the recurring benefits equate to more than 67 million dollars. The change also saved USAREUR 2756 manyears of effort.

However, while achieving these gains, DARCOM incurred increased recurring costs of 10.5 million dollars and 433 depot spaces. These resource requirements were recognized, but overall manpower cuts disallowed any upward adjustments as the reader will recall from Chart I-3.

SUMMARY DSS—EUROPE BENEFITS

<u>NON-RECURRING BENEFITS</u>	<u>FY 78 \$</u> <u>(MILLIONS)</u>	<u>MANYEARS</u>
INVENTORY REDUCTION	- 73.8	
PIPELINE REDUCTION	- 53.3	
	<u>\$-127.1</u>	
<u>RECURRING BENEFITS</u>		
EUROPE DEPOTS	-57.8	-2154
USAMMAE/UMMC	- 9.3	- 602
	<u>\$-67.1</u>	<u>-2756</u>

DARCOM RECURRING COSTS

<u>ACTIVITY</u>	<u>FY 78 \$</u> <u>(MILLIONS)</u>	<u>AIF</u> <u>SPACES</u>
CONUS DEPOTS	\$+10.5	+433

I-18

SINGLE MANAGER FOR CONVENTIONAL AMMUNITION (SMCA) FUNCTIONS

Additional missions have also been placed on DARCOM. SMCA is typical of one where we were given the responsibility but not all of the required resources (Chart I-19). OSD appointed the Army and, in turn, DARCOM became Single Manager for Conventional Ammunition for all the military departments. At present in Phase I, DARCOM performs the procurement, production, wholesale inventory, transportation, and traffic management functions.

Phase 2, when (and if) approved, will result in an expanded role to include establishing a defense NICP and NMP. This will, of course, cause an increase in such functions as items managed, maintained, and transported.

SINGLE MANAGER FOR CONVENTIONAL AMMUNITION – FUNCTIONS

PHASE I

**PROCUREMENT AND PRODUCTION OF
CONVENTIONAL AMMUNITION**

WHOLESALE INVENTORY MANAGEMENT

TRANSPORTATION AND TRAFFIC MANAGEMENT

PHASE II (IF APPROVED)

ESTABLISH DEFENSE NICP

ESTABLISH DEFENSE NMP

INCREASE IN ITEMS MANAGED

**INCREASE IN TRANSPORTATION MOVEMENT
RESPONSIBILITIES**

SINGLE MANAGER FOR CONVENTIONAL AMMUNITION

Chart I-20 shows the shortfall in personnel resources that DARCOM has experienced in Phase I. An additional shortfall will be experienced if Phase II is approved without a corresponding shift of manpower from the other Services.

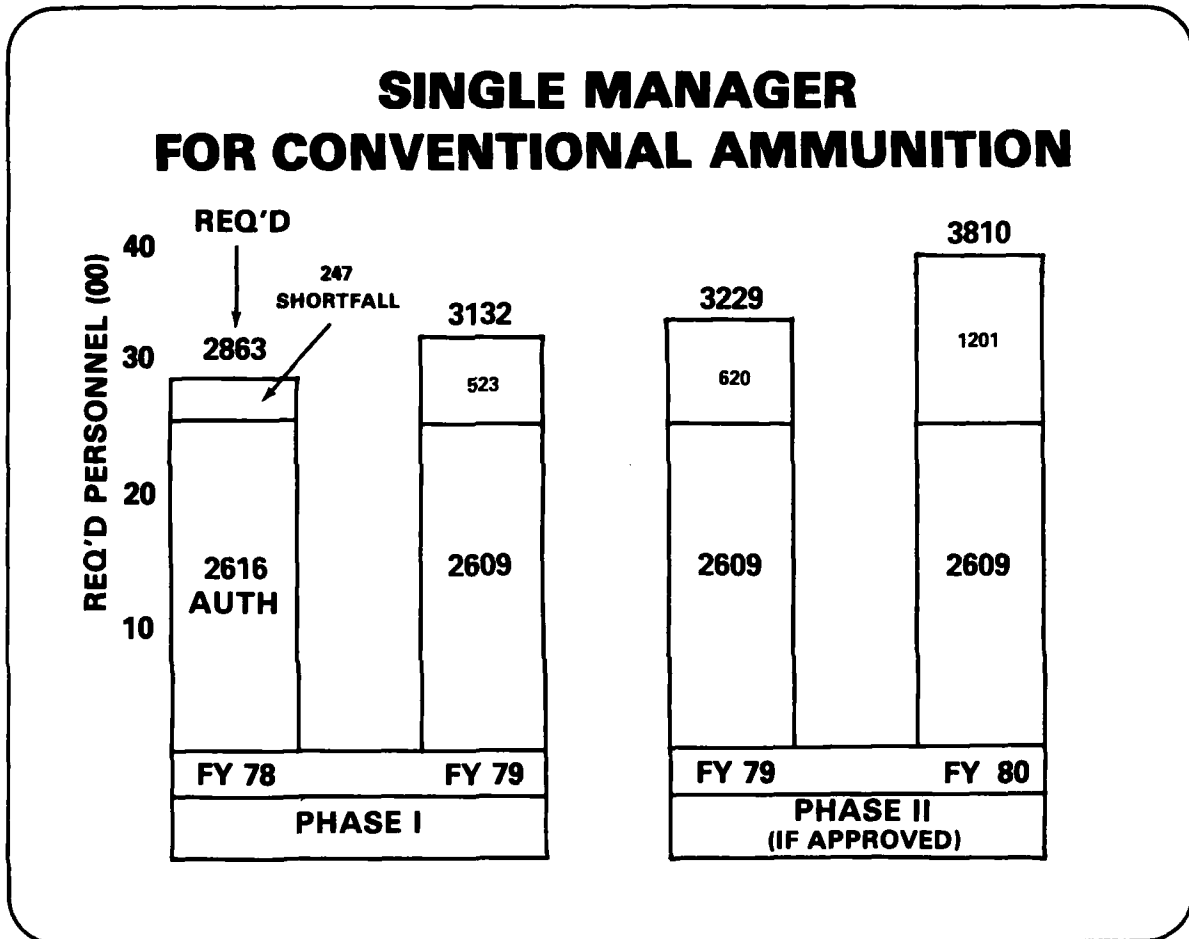

I-20

NEW MISSIONS

Chart I-21 displays other new missions gained by DARCOM since 1975. In most cases we received the resources associated with the new mission—but total manpower has steadily declined.

NEW MISSIONS

	<u>PERS REQ'D</u>	<u>PERS REC'D</u>	
APR 75 INTERNATIONAL R&D	30	23	- 7
JAN 76 PRODUCTION READINESS REVIEWS FOR DA	10	3	- 7
JUL 76 STOCKAGE OF DLA ITEMS IN AREA-ORIENTED DEPOTS (NEW CUMBERLAND)	254	254	0
JUL 76 OVERSEAS DEPOTS (MAINZ AND OBER-RAMSTADT)	2792	2792	0
SEP 76 TACTICAL DATA SYSTEMS SOFTWARE SERVICES TO PM ARTADS	123	123	0
DEC 76 TACTICAL AND STRATEGIC EW/SIGINT	732	657	-75
NOV 77 EXECUTIVE AGENT FOR SECURITY ASSISTANCE	22	22	0
JAN 78 MAINTAIN FORCE MODELS & DATA BASES FOR COMM-ELECTRONICS/ELECTRO-MAGNETIC COMPATIBILITY/ANALYSIS AND VULNERABILITY CONCEPT STUDIES	15	15	0
TOTALS	<u>3978</u>	<u>3889</u>	<u>- 89</u>

I-21

MANDATED PROGRAMS

In addition to new missions, the increased requirements of mandated programs continue to erode our available resources (Chart I-22). The manpower requirements to support drug and alcohol abuse, energy conservation, the EEO program, CITA, environmental protection, small business, and physical security have increased by at least 1,867 since 1970.

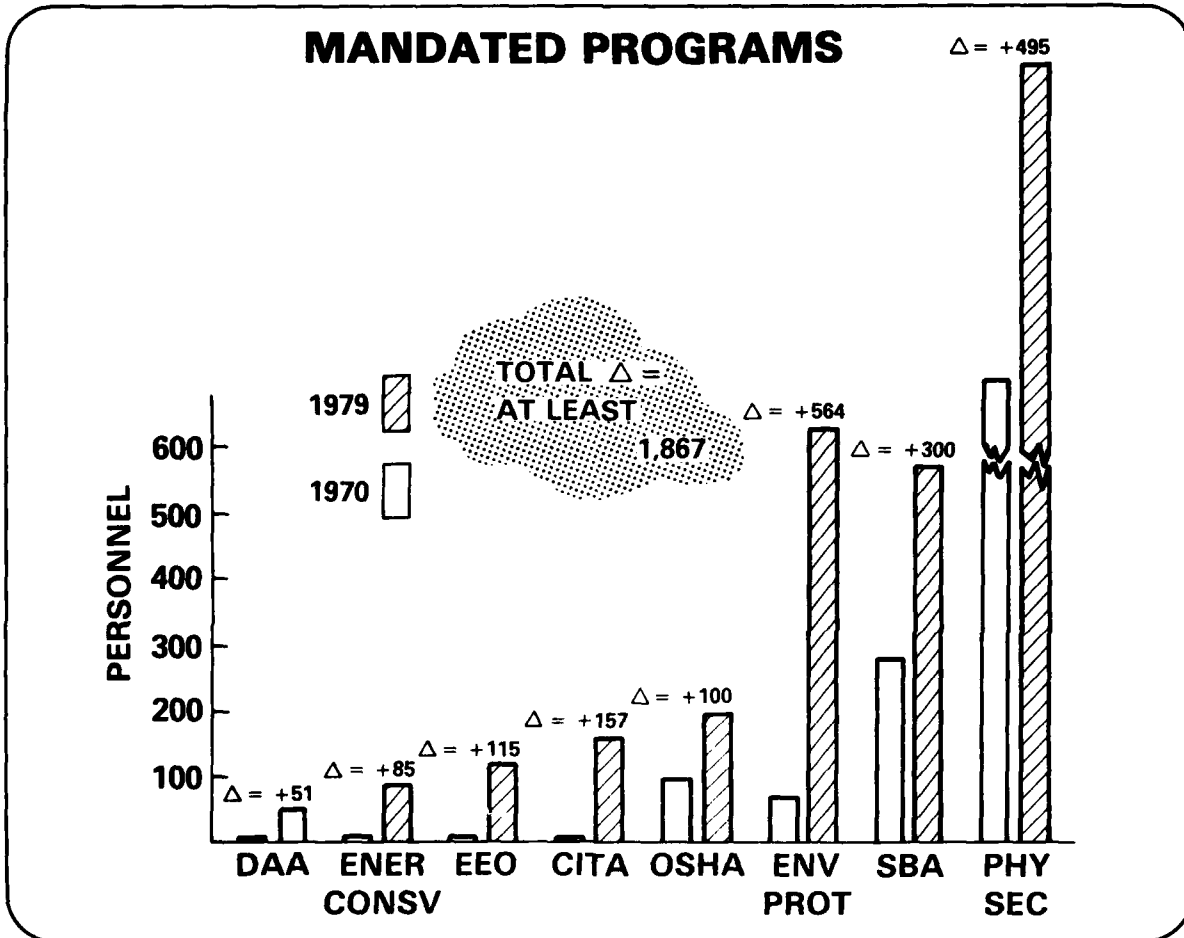

I-22

These "overhead" increases, during a period of retrenchment, cause considerable apprehension as we view the new weapon and materiel systems coming into the inventory over the next five years.

SYSTEMS SCHEDULED FOR FIELDING DURING THE NEXT FIVE YEARS

Chart I-23 shows the incoming major systems to be fielded over the five year period. These systems today are creating development and materiel readiness workloads on DARCOM.

NEW SYSTEMS

AIR DEFENSE

- * STINGER
- * ROLAND
- * PATRIOT
- * DIVAD GUN

ARMOR

- M60A3
- * XM-1
- 120MM GUN
- * FVS
- CVS
- IFV
- IFV FPW
- VRFWS-S
- * ITV

AVIATION

- * UH-60
- * CH-47D
- * ASH
- * RPV
- * HELLFIRE
- * AAH-64
- XM 788/789
- TADS/PNVS

COMMUNICATIONS, COMMAND & CONTROL

- * SOTAS
- * TOS
- TACSATCOM
- * MOBILE SUBS EQUIP
- * AUTO COMM CENT
- * AN/TTC-39
- AN/TYC-39
- * NAVSTAR-GPS
- * SINGARS V
- AUTOSEVOCOM II
- PLRS
- REMBASS
- JTIDS

ENGINEER

- SLUFAE
- FAMECE/UET
- GEMSS

INTELLIGENCE

- TRAILBLAZER
- QUICKLOOK
- TACELIS
- QUICK FIX
- TACJAM
- TECHNICAL ESM

FIELD ARTILLERY

- * COPPERHEAD
- BCS
- * GSRS
- FAMAS
- * PERSHING II
- XM736
- * AN/TPQ-37
- * LTD/GLLD
- * TACFIRE

INFANTRY

- FASCAM
- SAW
- VIPER
- LWCMS
- DNT

*MAJOR SYSTEMS

I-23

We now move to part II of our analysis—the impact of the cuts on logistics readiness.

**MANPOWER CUTS—WORKLOAD TRENDS—
MISSION IMPACTS—LOG READINESS**

Section II relates the manpower cuts and other factors described in Section I to workload trends, and describes the impact on DARCOM's logistics readiness mission (Chart II-1).

**MANPOWER CUTS -
WORKLOAD TRENDS -
MISSION IMPACTS -
LOG READINESS**

II-1

First, it is necessary to develop a methodology which considers the size of the Army's materiel inventory and relates that inventory to its use in the field. In doing so, a relationship between the inventory, its use, and DARCOM's workload can be established.

INTENSITY OF OPERATIONAL EMPLOYMENT

The technique is entitled INTENSITY OF OPERATIONAL EMPLOYMENT (IOE). The logic behind the technique is relatively simple.

As shown on Chart II-2, inventory and requisitions are the two quantifiable elements. The top portion depicts notionally the total fielded inventory with little activity. Consequently, very few requisitions result.

The center scene describes more use of the systems/equipment. Consequently, supply and maintenance activity pick up and increasing demands are being placed on DARCOM. Note also that the inventory quantity is increasing. (The IOE concept is applicable whether the inventory increases, decreases, or remains constant.)

The lower third shows a dramatic increase in density and use. Requisition activity increases considerably.

DARCOM has developed a method to quantify the inventory and field use of that inventory. With this intelligence DARCOM can accurately establish the required logistics response and resource requirements.

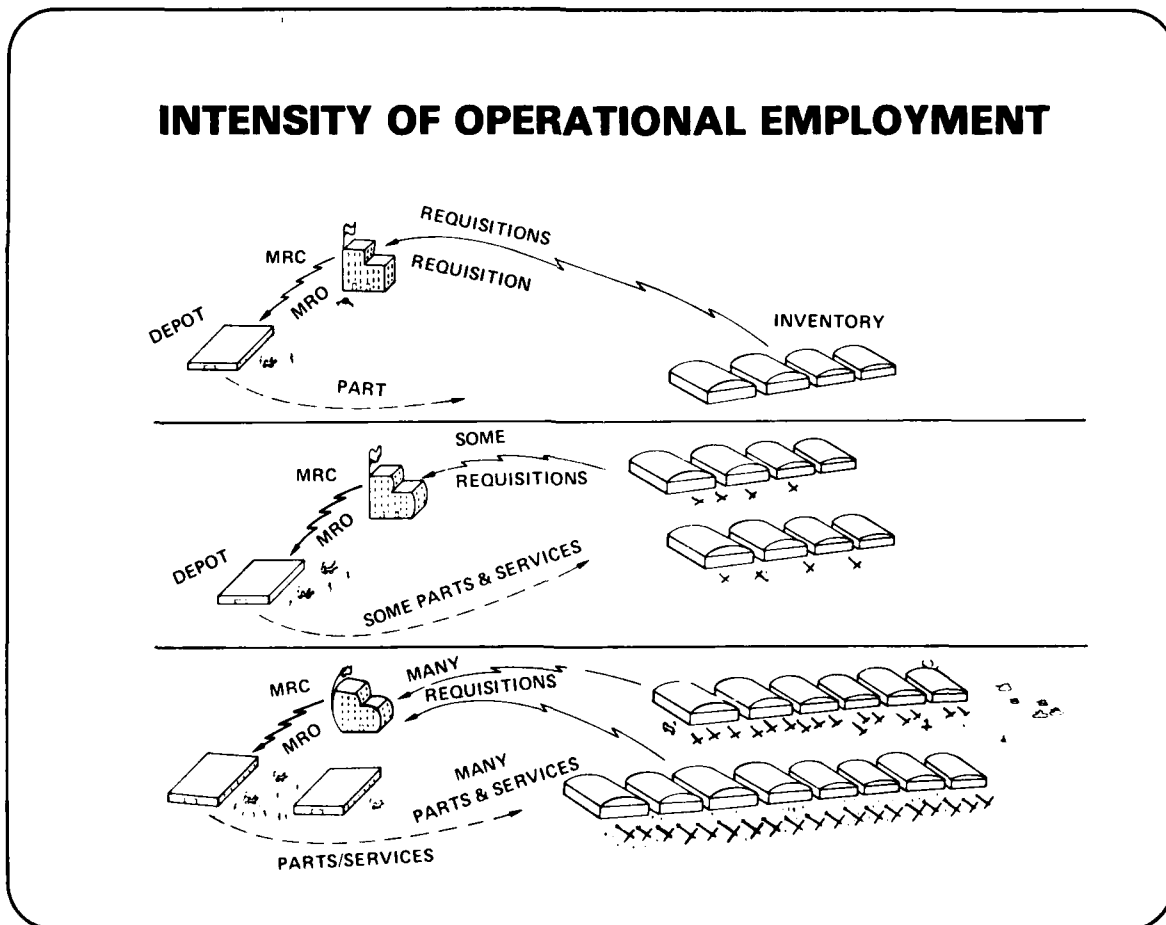

II-2

Our technique for relating equipment in the field and its use to internal DARCOM requirements follows.

CONCEPT OF INTENSITY OF OPERATIONAL EMPLOYMENT (IOE)

The aircraft commodity was used to develop the technique we employ.

We found fielded aircraft density, when factored by total flying hours, correlated very closely with DARCOM materiel readiness personnel required to support those aircraft and their field use.

As displayed in Chart II-3a, aircraft density relates to aircraft items managed by TSARCOM(AVSCOM), and in 3b, flying hours relate to aircraft requisitions processed by TSARCOM(AVSCOM). If one accepts the thesis that aircraft density and flying hours accurately describe the operational IOE, then, by inspection, the corresponding FSN's and requisitions establish a similar relationship for logistics IOE. Items managed and requisitions processed, therefore, are the variables in the IOE formula shown in the center of the chart.

As shown by the regression model depicted in Chart II-3c, using items managed factored by requisitions (IOE), we derive a good correlation when applied against TSARCOM(AVSCOM) Materiel Readiness personnel—until 1974.

As depicted in Chart II-3d, when IOE was related to total DARCOM materiel readiness personnel, we obtained an even higher coefficient of correlation. Between FY 74 when the Army stabilized its strength and FY 78, we show a 12% decline in personnel strength, while at the same time experiencing a sharp increase in workload (IOE). The increase in workload is shown as the distance between the FY 74 and FY 78 plot points measured on the horizontal axis.

The decrease in personnel and simultaneous increase in workload is the reason for deteriorating performance shown later in this section.

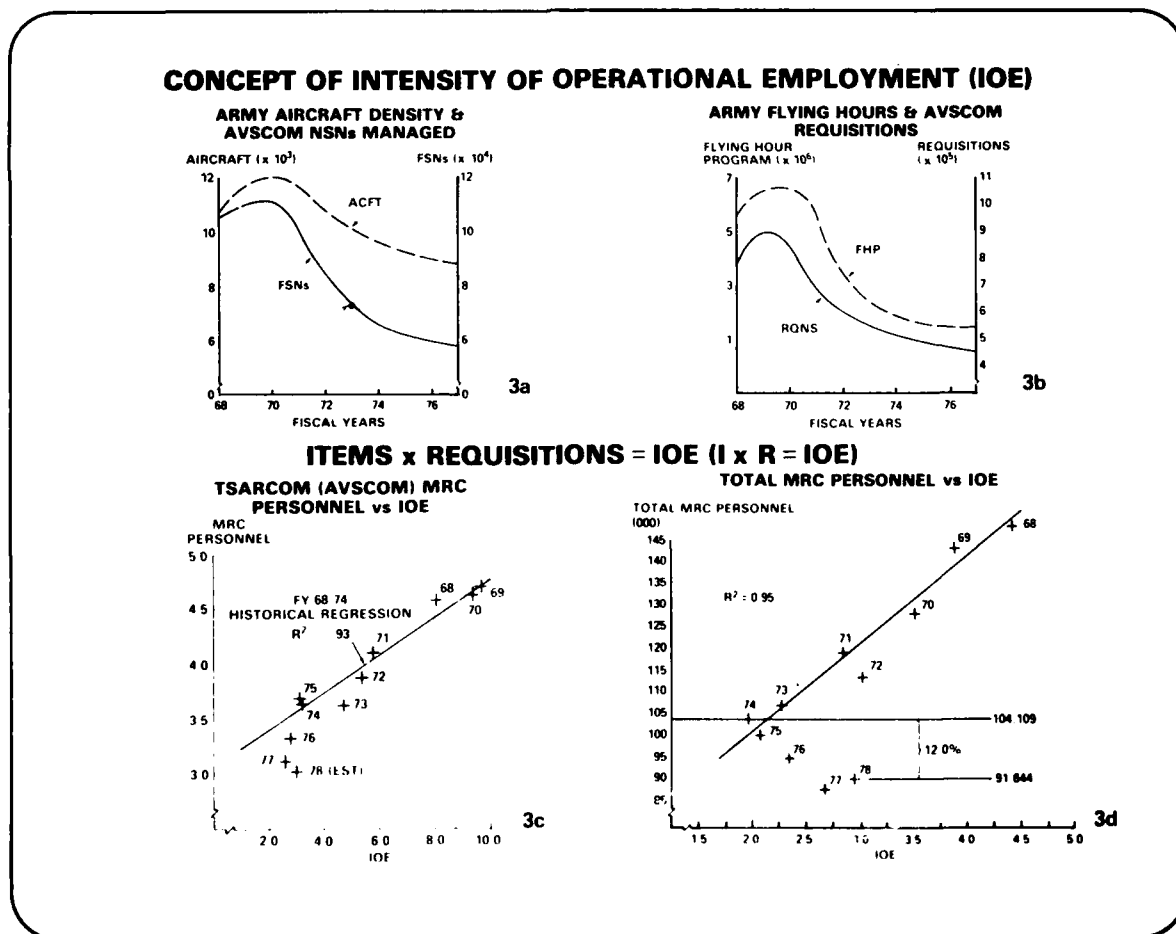

II-3

First, however, we will confirm the increase of line items managed and requisitions processed, the variables in our IOE formula.

LINE ITEMS MANAGED/AUTH CEP

First, line items managed (Chart II-4).

Note the dramatic increase in line items managed—and a slight decline in item management personnel.

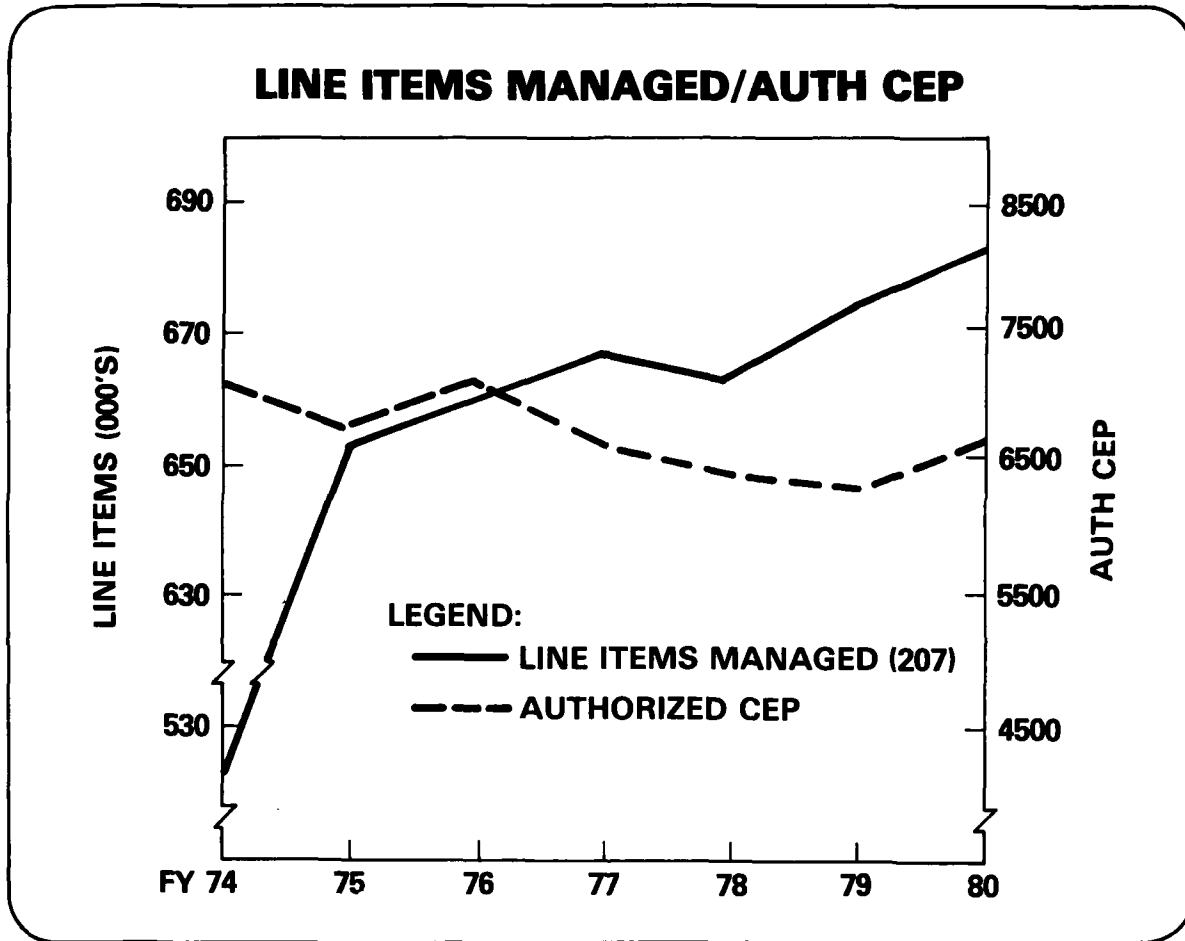

II-4

The above item data is based on the RCS 207 Report.

Based on estimates by DARCOM item managers, total net line items to be managed by FY 83 will approximate 777,000. This increase is being caused by new systems being introduced within the next five years, and the slow washout of older line items used in support of Security Assistance.

REQUISITIONS PROCESSED/AUTH CEP

Likewise, requisitions processed, also show a dramatic increase with a slight decrease in personnel (Chart II-5). Here we note the presence of DSS, new FMS requirements, and of course, the increase in line items managed.

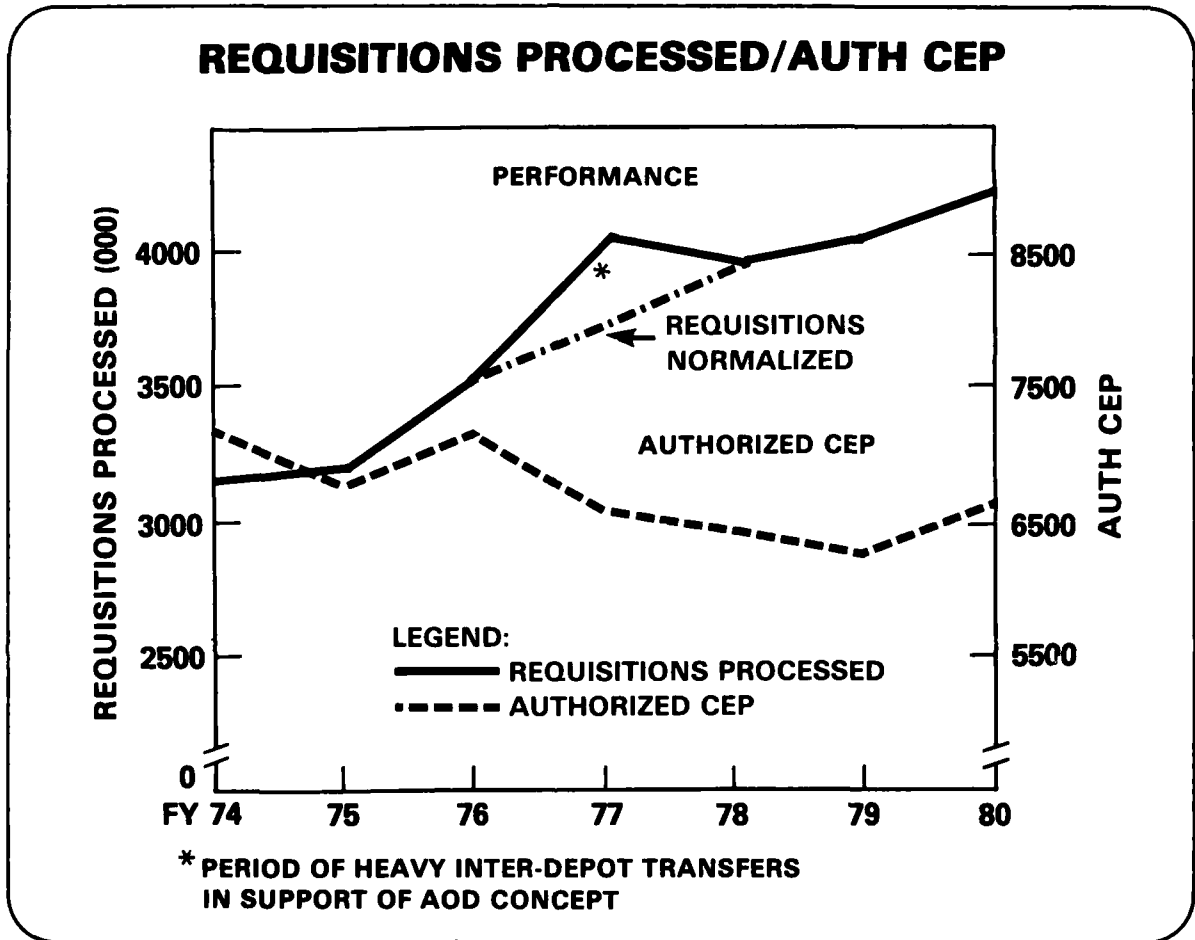

II-5

New line items, increased requisitioning activity, and new weapon systems also affect the procurement activity of our Readiness Commands. Procurement will be examined next.

DARCOM RESOURCE TRENDS— CONSTANT DOLLARS BY APPROPRIATION

Line items increase as new systems enter the inventory and field support increases as more equipment intensive divisions enter the force structure.

Accordingly, there is a sharp increase in PA,A funds. Note that the OMA trend (OMA pays procurement people) is relatively flat indicating an absence of people to properly plan, execute and administer the increased PA,A activity.

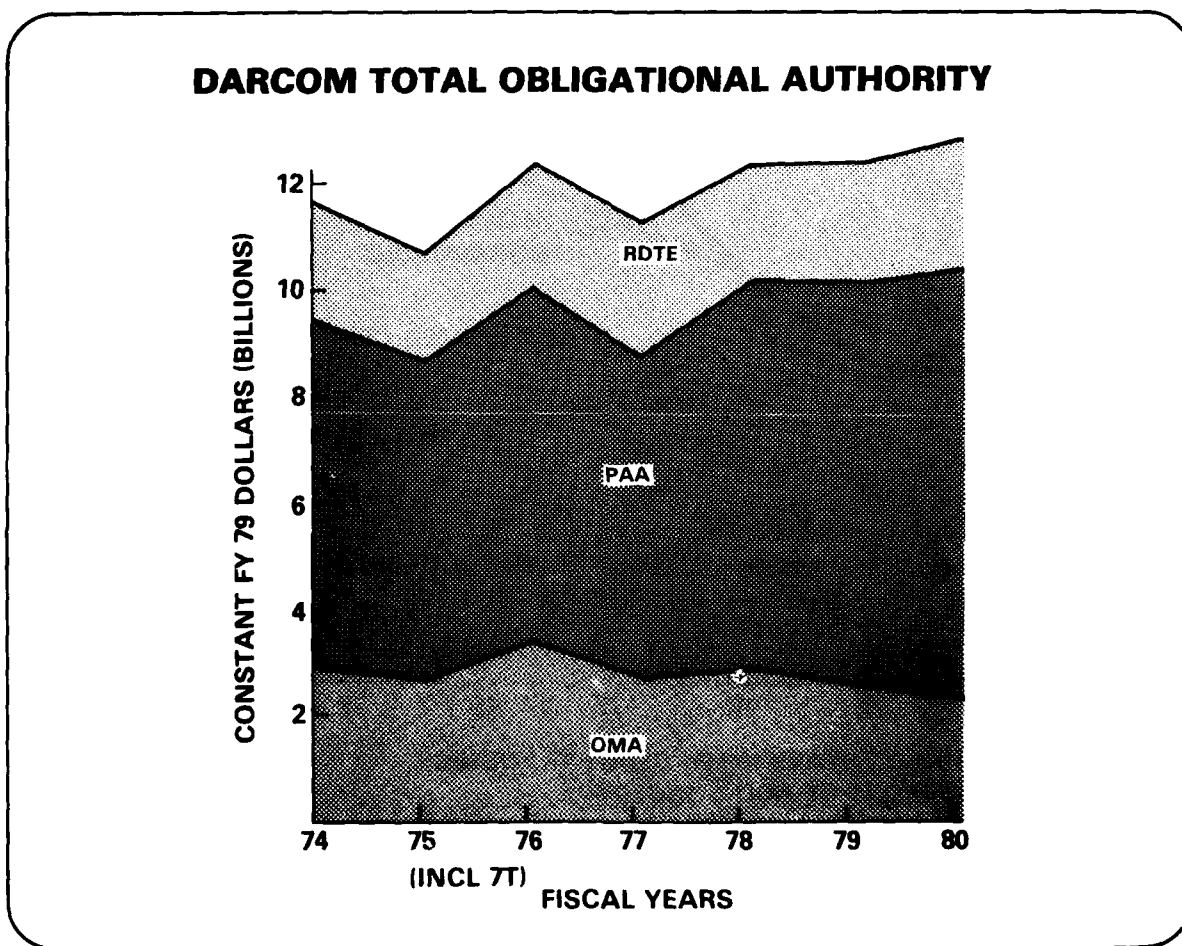

II-6

The absence of adequate procurement personnel is confirmed by the trends displayed on the next chart.

BACKLOG OF PROCUREMENT ACTIONS (PA)

End strength is declining while the workload, as predicted, is rapidly increasing.

Because of this imbalance, the backlog is at an unprecedented high. An acceptable backlog in PA's is in the 15,000 range and is shown on Chart II-7 as the band below the total backlog line. However, DARCOM's all time excess high of 30,000 PA's seriously hindered the effort to obligate the FY 78 procurement programs (and other appropriations) against the plan. Outlays, a consequence of obligations and a major factor in national economic planning, were likewise affected.

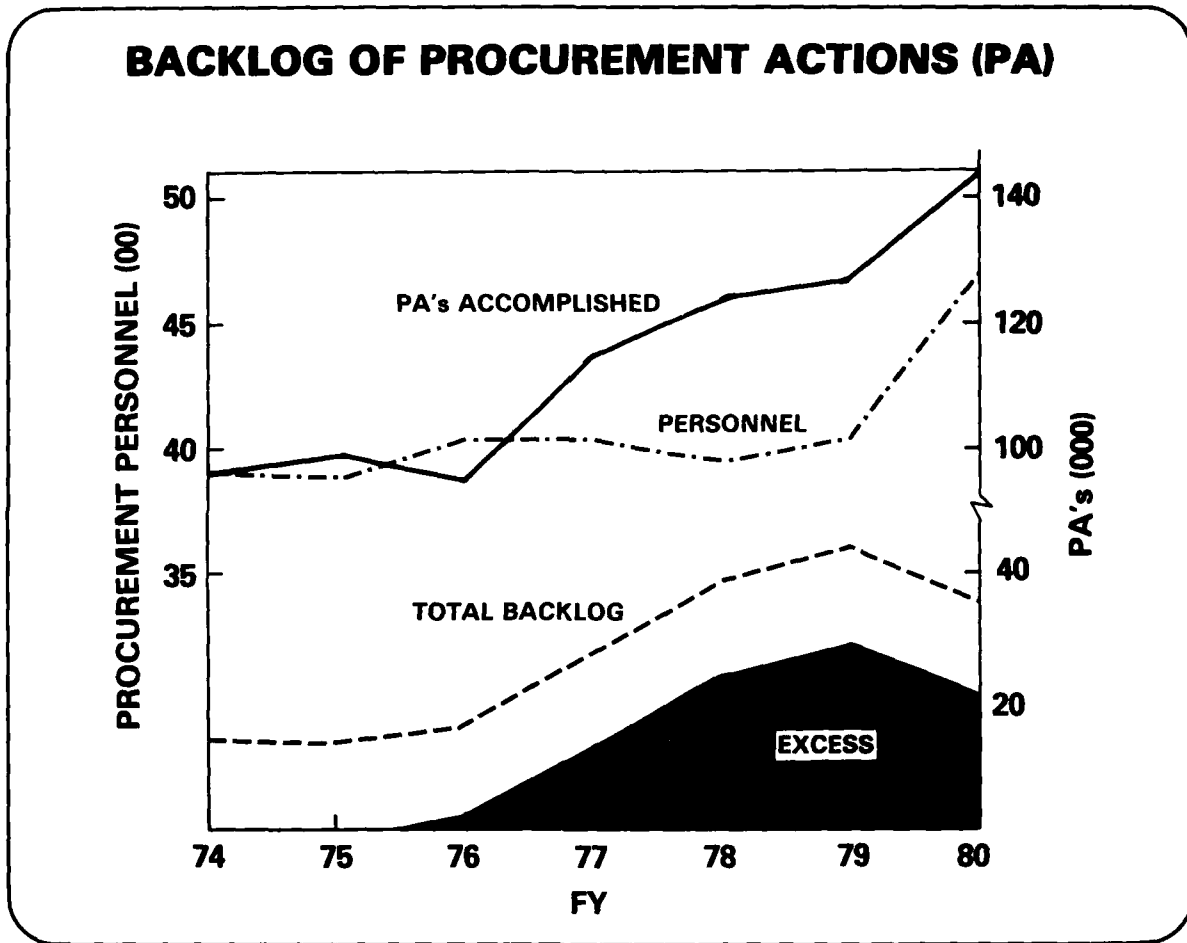

II-7

PA's ACCOMPLISHED/HIGH VALUE PA's AS % OF TOTAL

To compound the procurement problem, the ratio of contracts over \$10,000 to contracts under \$10,000 is rapidly increasing (Chart II-8). The high value PA's require 13.5 times the effort of low value contracts. In FY 75, high value contracts were 16% of the total awards. Today they stand at 18%, and by FY 80, they will be more than 22%.

As a management improvement, DARCOM requested that Department of the Army initiate the required legislation to raise the value of low value contracts from \$10,000 to \$25,000—and also accommodate out year inflation through the addition of an escalation factor. On 18 January 1979 this request was denied by DA.

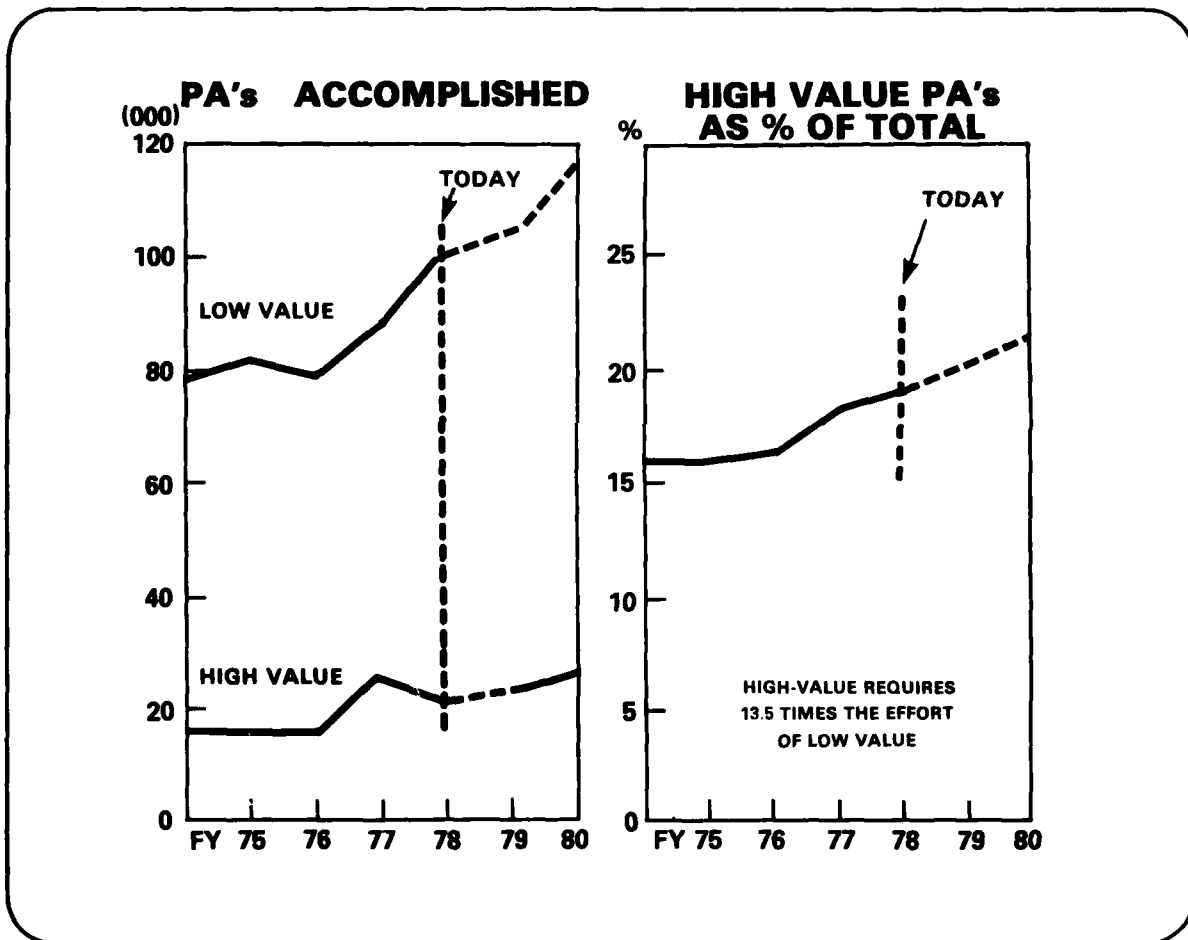

II-8

AGING OF PROCUREMENT ACTIONS

Aging of procurement actions, a key indicator of our declining procurement performance, is displayed on Chart II-9.

In FY 75, 62% of the documents were less than 60 days old. Currently, only 40% are under 60 days. The median age of all PWDs has jumped from the 31-60 day range to the 61-90 day range. In short, it takes longer now to process a PWD and award a contract than it did in FY 75.

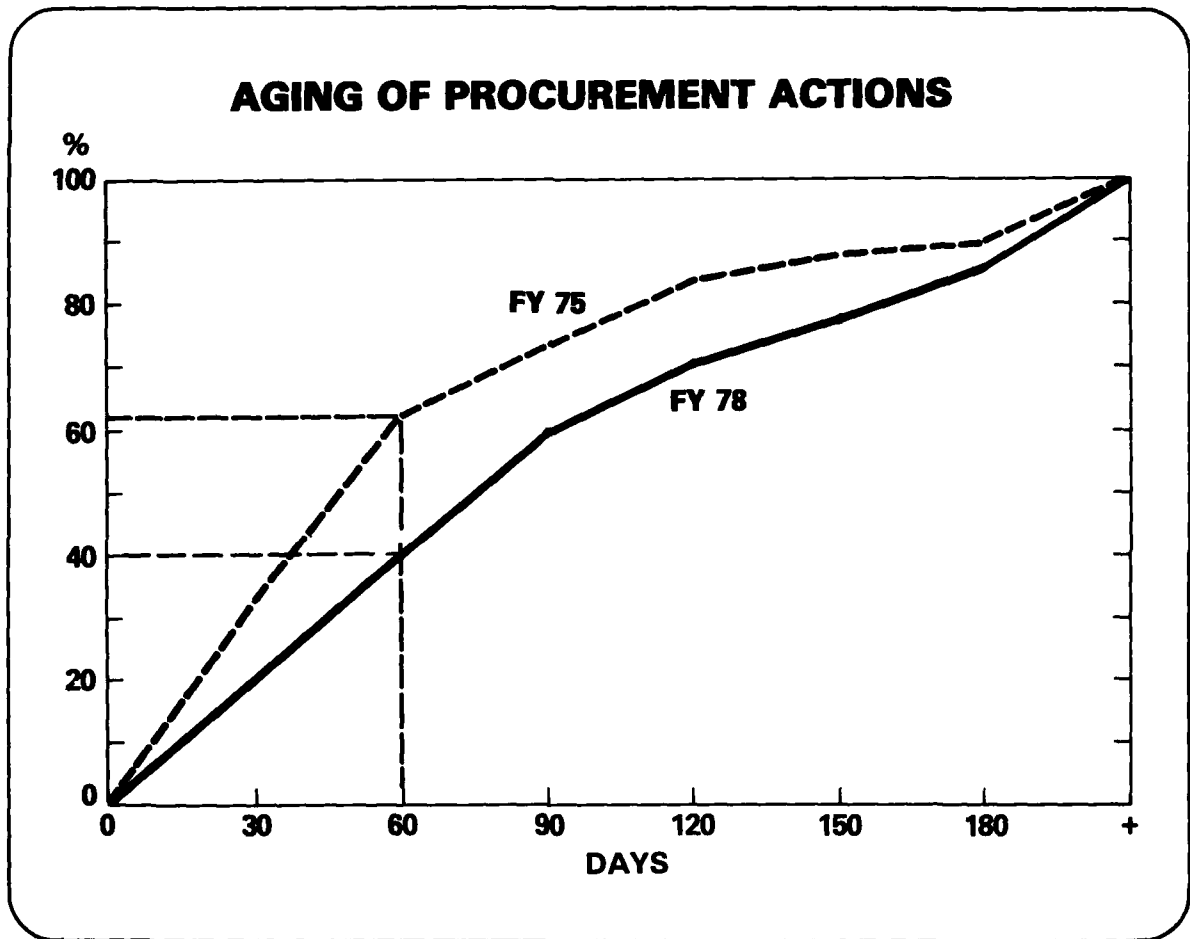

II-9

Productivity has been stressed to offset part of this shortfall, and is described next.

CENTRAL PROCUREMENT ACTIVITIES PRODUCTIVITY

An upward productivity trend has been achieved as shown on Chart II-10. We now accomplish roughly 31.5 PA's per person per year, however, this trend probably will level during the next several years. OMA costs per PA, also, should level.

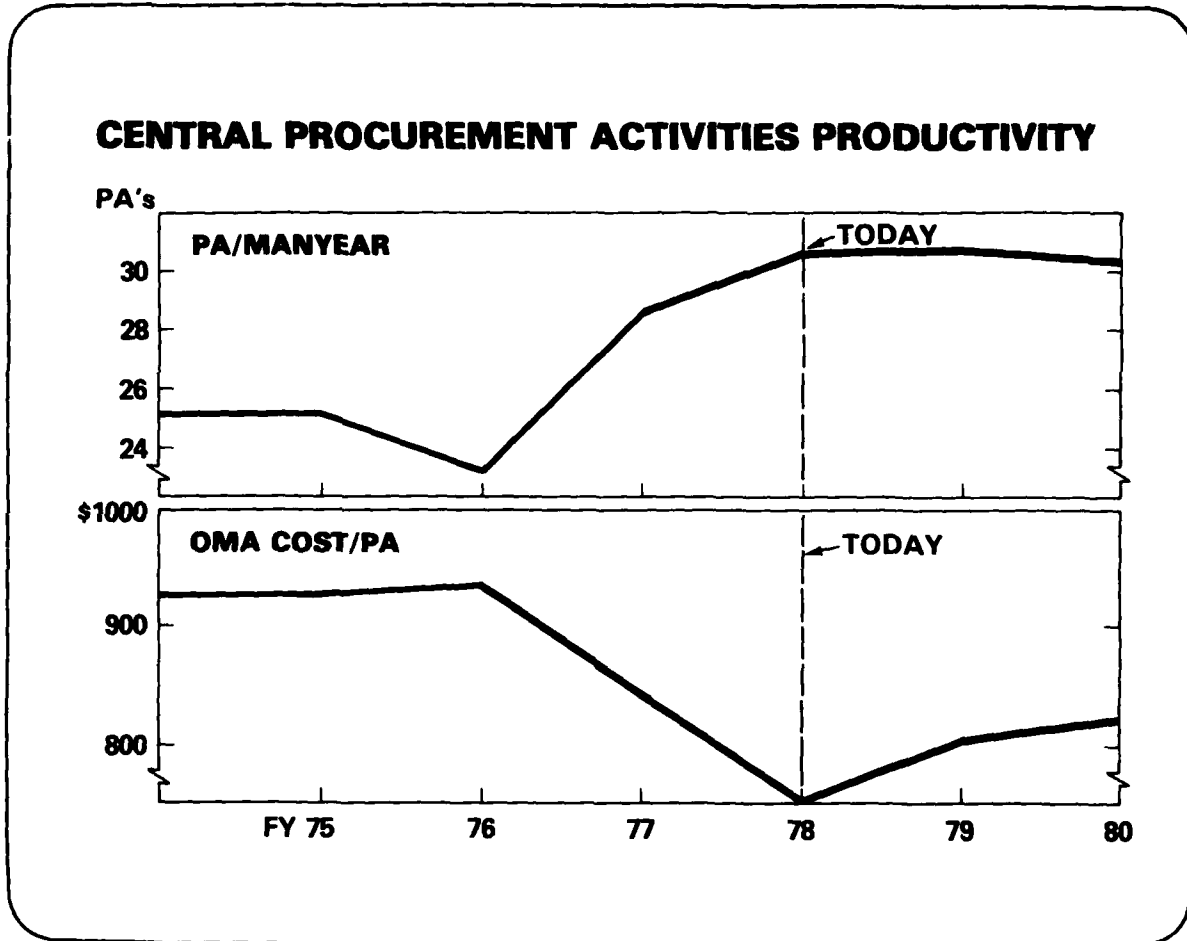

II-10

However, this productivity trend causes some concern. We have recognized an overall slump in the quality of our procurement actions and other procurement functions as shown on Chart II-11.

QUALITY OF OVERALL PROCUREMENT OPERATIONS

While a maximum effort is being directed to obligating the program according to plan, other functions on Chart II-11 are being adversely impacted. For instance, we are unable to perform adequate procurement planning for FY 79. In some cases, funds are tied up that could be deobligated and reprogrammed to satisfy other requirements. One area in the high dollar value procurements that is being neglected due to personnel shortages is the DARCOM Should Cost Studies Program. In some cases, Should Cost Studies on selected sole source procurements valued in excess of \$1 million dollars, are not being performed at all. In fact, DARCOM's goal under the Should Cost Study Program for FY 78 was 12 – only 6 were performed. The savings realized from these 6 Should Cost Studies is \$119 million from a proposed cost of \$600 million. The projected loss of savings due to lack of resources has been estimated to be between \$30 million and \$40 million.

Another area of neglect due to the manpower problem is that of contract close-outs. In many cases, funds are tied up that could be deobligated and reprogrammed to satisfy other requirements – at a time when the U.S. Government is paying roughly 7% to borrow money.

Other shortfalls are self-explanatory.

QUALITY OF OVERALL PROCUREMENT OPERATIONS FUNCTIONS SACRIFICED, DEFERRED, OR NOT PERFORMED AT ADEQUATE LEVEL

- **PROCUREMENT PLANNING**
- **SHOULD COST STUDIES**
- **CONTRACT CLOSE-OUTS**
- **PROCUREMENT CAREER TRAINING**
- **REDUCED CALIBRE/DEPTH OF PRE-CONTRACT BOARD REVIEWS**
- **PRODUCTION MANAGEMENT**
- **PRODUCTION LEADTIME FORECASTING**
- **TIMELY DEFINITIZATION OF LETTER CONTRACTS**
- **FINALIZATION OF CHANGE ORDERS/TASK ORDERS**
- **IMPROVEMENT OF ADP SYSTEMS**
- **MAINTENANCE OF BIDDERS' LIST SYSTEM**
- **TIMELINESS AND COMPLETENESS OF COST AND PRICE ANALYSIS**
- **TIMELY ISSUING AND UPDATING POLICY**
- **POST-CONTRACTS REVIEWS**

II-11

The increased workload (requisitions processed/procurement actions) and decreased manpower described in this section have resulted in an overall drop in NICP performance as shown next.

SUPPLY PERFORMANCE TRENDS— DARCOM NICPs—TOTAL

We now face a decrease in receipt of new inventory from contractors, increased demands from the field for more inventory, and fewer personnel in our NICP's and depots.

The obvious result is that: requisitions received generally are increasing; stock availability is declining; back orders are increasing; and on-time processing of requisitions has fallen below established DA goals (Chart II-12.)

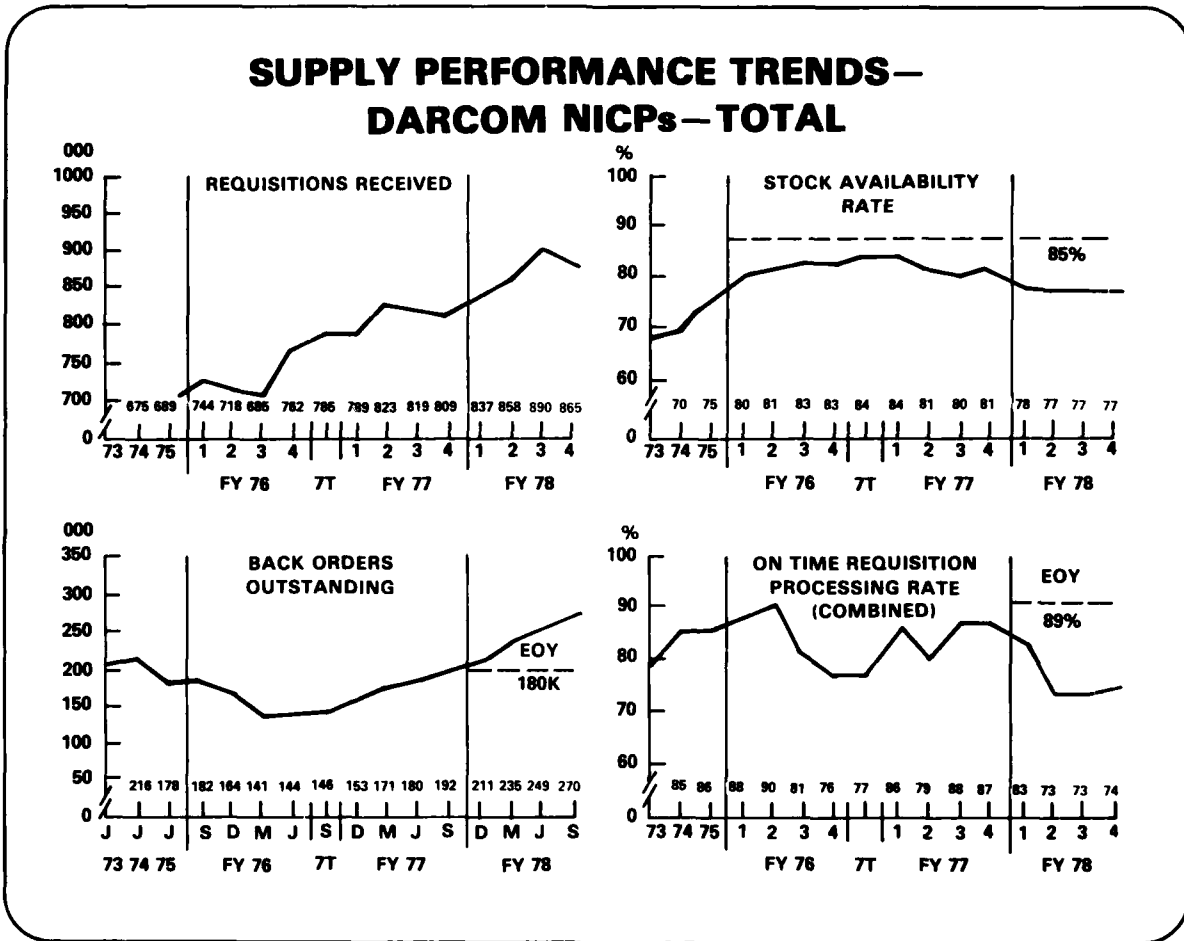

II-12

SUPPLY PERFORMANCE TRENDS— DARCOM NICP—NORS

A similar trend is noted in Not Operationally Ready—Supply (NORS) requisitions (Chart II-13).

NORS demands are up, both for stocked and non-stocked items. This is a direct indication that field equipment deadlines are increasing.

DARCOM's ability to reduce field NORS is also declining, as shown by the other three graphics.

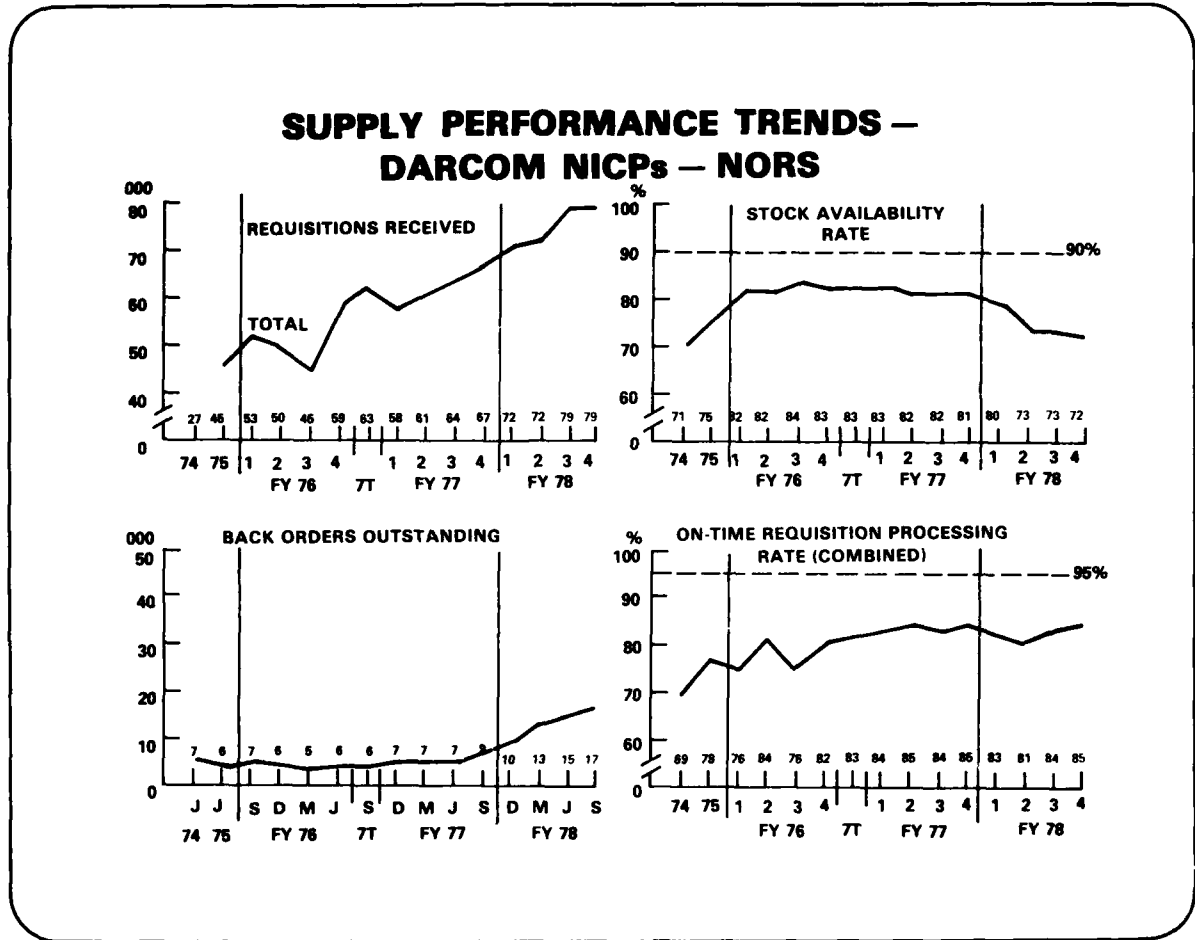

II-13

STOCK AVAILABILITY BY COMMODITY GROUP

A closer examination of materiel stock availability by commodity group is shown in Chart II-13A. Artillery, missile, tracked vehicle and wheeled vehicle systems/equipments show a steady decline since the first quarter FY 77. Of particular concern is the availability drop in critical combat/support systems, such as the M109 SP Howitzer, M163 Vulcan AD gun, HAWK AD missile, TOW anti-tank missile, M60 main battle tank, M113 armored personnel carrier, and the M35 2½ ton cargo truck.

WEAPON SYSTEM STOCK AVAILABILITY RATES

COMMODITY GROUP	SYSTEM	FY 1977 %				FY 1978 %			
		1st QTR	2d QTR	3d QTR	4th QTR	1st QTR	2d QTR	3d QTR	4th QTR
AIRCRAFT	AH-1G COBRA	84	83	83	82	83	81	88	91
	CH-47 CHINOOK	87	88	87	87	87	87	87	87
	UH-1 IROQUOIS	85	87	86	87	87	84	85	81
	TOTAL	86	87	86	86	86	85	86	83
ARTILLERY	M102 HOWITZER	84	84	80	84	86	83	77	74
	M109 HOWITZER	85	80	77	78	78	80	75	73
	M29 MORTAR	87	78	74	76	76	74	73	76
	M163 GUN (VULCANI)	73	67	64	63	73	64	76	61
	TOTAL	81	76	73	73	76	75	75	70
COMM-ELECTR	AN/PPS 4-5 RADAR	67	62	59	62	67	74	71	73
	AN/GRC 106 RADIO	63	68	68	73	70	73	70	65
	TOTAL	65	65	63	68	69	73	70	68
COMMODITY GROUP	SYSTEM	FY 1977 %				FY 1978 %			
		1st QTR	2d QTR	3d QTR	4th QTR	1st QTR	2d QTR	3d QTR	4th QTR
MISSILES	CHAPARRAL	86	85	79	79	83	78	81	87
	HAWK	83	76	82	75	67	71	61	58
	HERCULES	80	87	93	86	84	86	88	85
	LANCE	90	86	83	83	84	81	87	80
	PERSHING	74	72	69	74	71	74	73	77
	TOW	74	68	76	76	70	69	76	74
	TOTAL	83	79	84	78	74	75	71	70
TRACKED VEHICLES	M60 TANKS	81	80	77	76	73	70	67	67
	M551 ARAAV	82	79	75	74	76	74	78	84
	M88 REC. VEH.	83	80	80	80	85	78	77	75
	M578 REC. VEH.	82	85	69	69	62	67	65	69
	M-113 APC	87	83	81	77	67	77	72	70
TOTAL	83	81	77	76	73	73	70	70	
WHEELED VEHICLES	1/4 & 1/2 TON VEH.	89	84	87	88	84	83	84	83
	GAMA GOAT	79	82	77	71	65	67	63	65
	M35 TRUCKS	91	81	82	82	75	71	79	79
	M123 TRUCKS	78	77	78	85	85	84	86	85
	TOTAL	87	83	84	84	79	78	80	79

SOURCE: MILSTEP

ZERO BALANCE ITEMS

As one might expect, line items in a zero balance condition are also increasing (Chart II-14).

Note the decline in zero balance items during the FY 74-76 time frame. This was a direct result of DARCOM's more effective management during the FY 72-74 period when we had sufficient manpower and dollar resources, and experienced a drop in IOE as shown on Chart II-3d. Since FY 76—a period of simultaneous workload increase and personnel decrease—the out-of-stock trend is worsening.

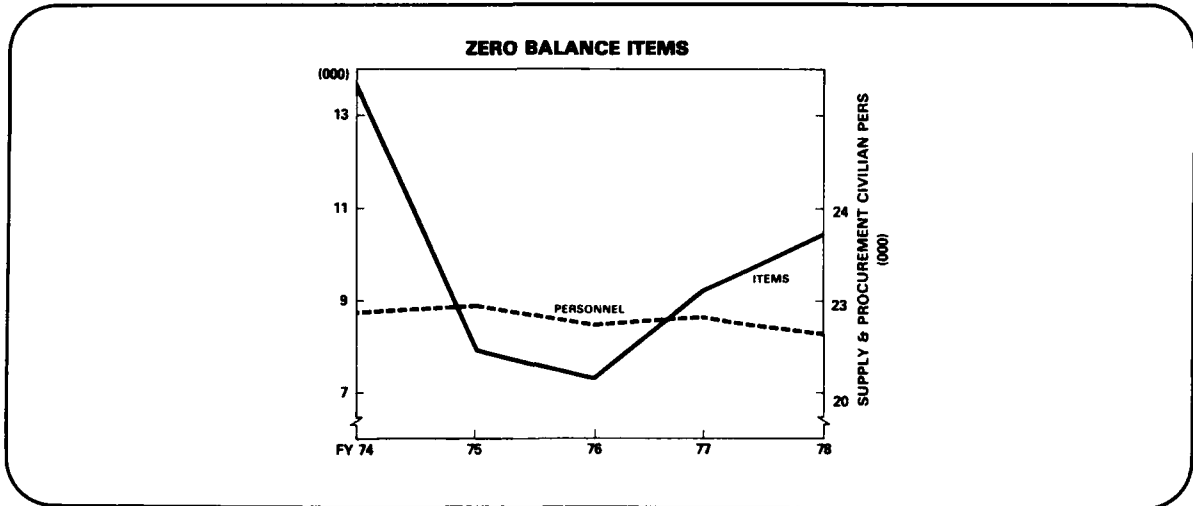

II-14

DEPOT ON-TIME RECEIVING RATE

As depot supply personnel were reduced between FY 73 through FY 76, performance related to receipt of the goods from contractors (and field returns) for storage and issue (Chart II-15) also declined. The slight increase in personnel in FY 77 resulted in better reporting and stowing performance in FY 78.

A second reason for improved reporting and stowage performance was the FY 78 emphasis on improving the on-time receiving rate. In instances such as this—which are driven by DA priorities—one performance indicator will temporarily improve, but to the detriment of other performance indicators. This seesaw action (where the commanders apply concentrated resources to the bad end of the seesaw) always results in some other critical function going bad.

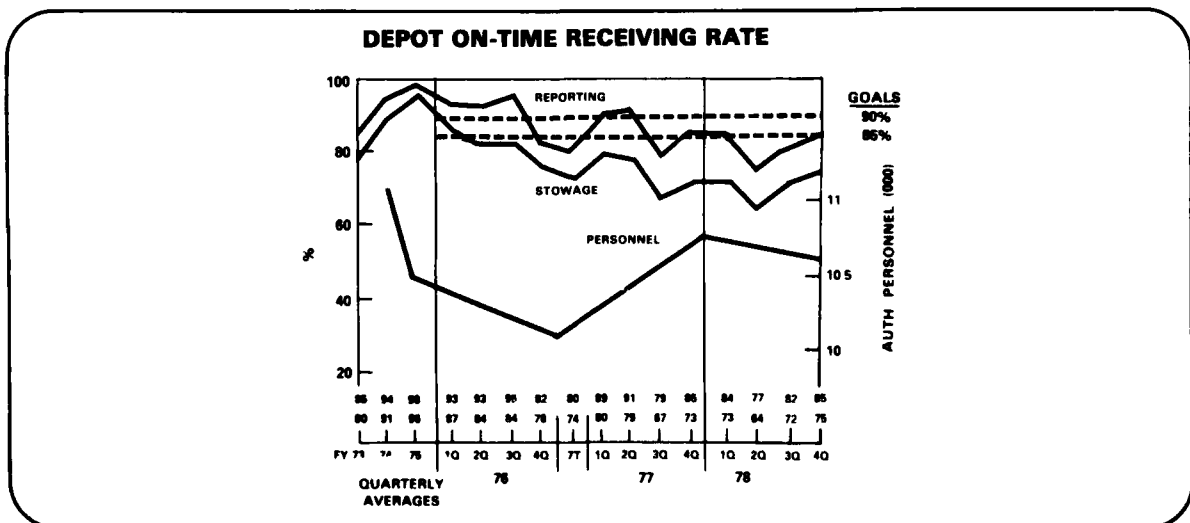

II-15

DEPOTS ON-TIME REQUISITION PROCESSING RATE

It takes the depots longer to process a requisition now (Chart II-16).

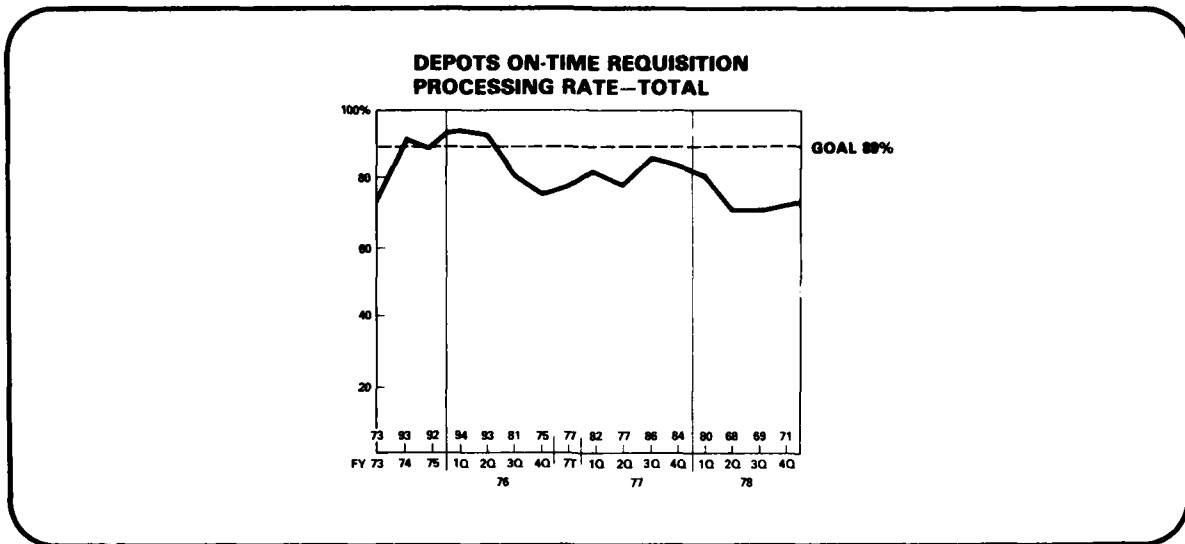

II-16

DEPOT ON-TIME REQUISITION PROCESSING RATE-NORS

The same condition exists for NORS requisitions (Chart II-17).

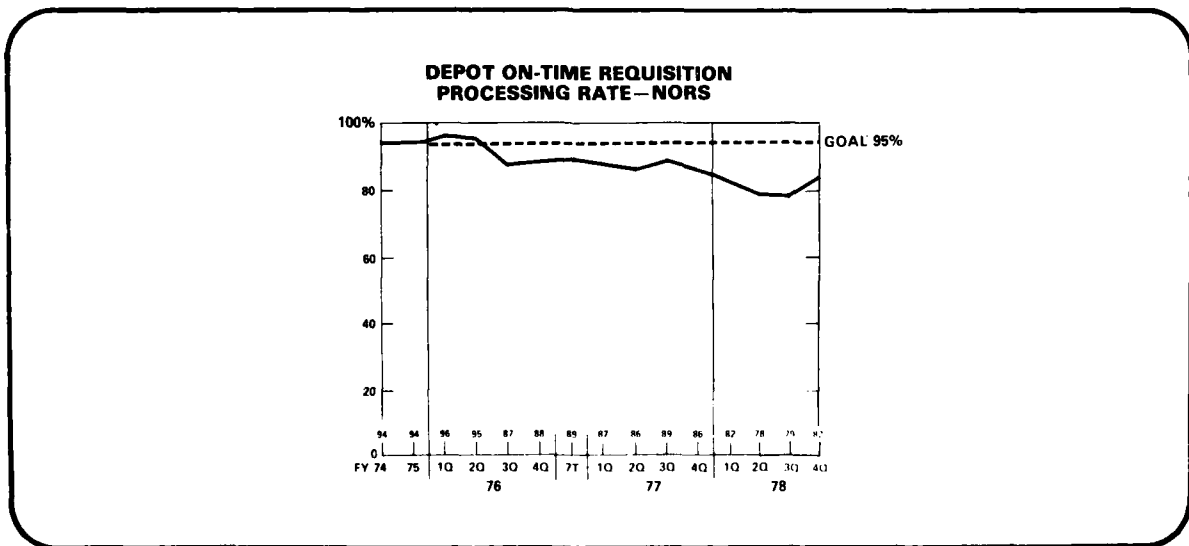

II-17

LOCATION SURVEY ACCURACY

As a result of sacrificing the effort required for inventory and rewarehousing in favor of shipping and receiving, one out of twenty depot inventory locations is inaccurate. This is a contributing factor to the fact that 23 out of every 100 requisitions becomes a backorder.

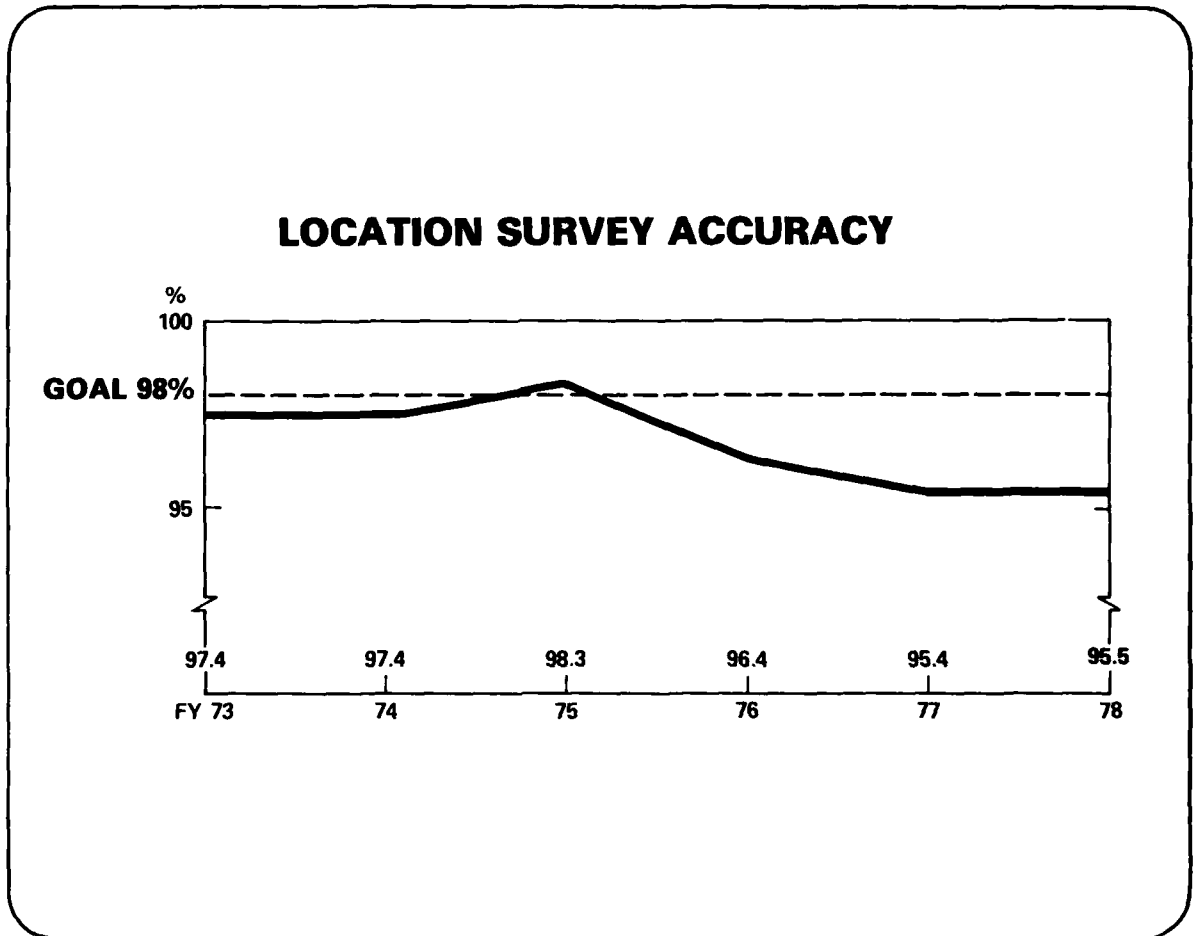

II-18

In summary, we have tracked the supply system from the time the manager becomes responsible for an item, until the time that item is shipped from a depot. DARCOM's performance is dropping in each instance—field performance will be likewise affected as the time lag catches up.

We next examine depot maintenance.

DEPOT MAINTENANCE PROGRAMS

With the rapidly increasing cost of new materiel acquisition, it is imperative that increased emphasis be placed on depot maintenance. Large cost savings are achieved in depot maintenance when contrasted with new buys. An example is the comparative cost of overhaul vs. new acquisition of the major components of the Improved Hawk weapons. The acquisition cost for nine major components of the I-Hawk system is approximately \$6 million. Overhaul costs are \$826,000—about 12%.

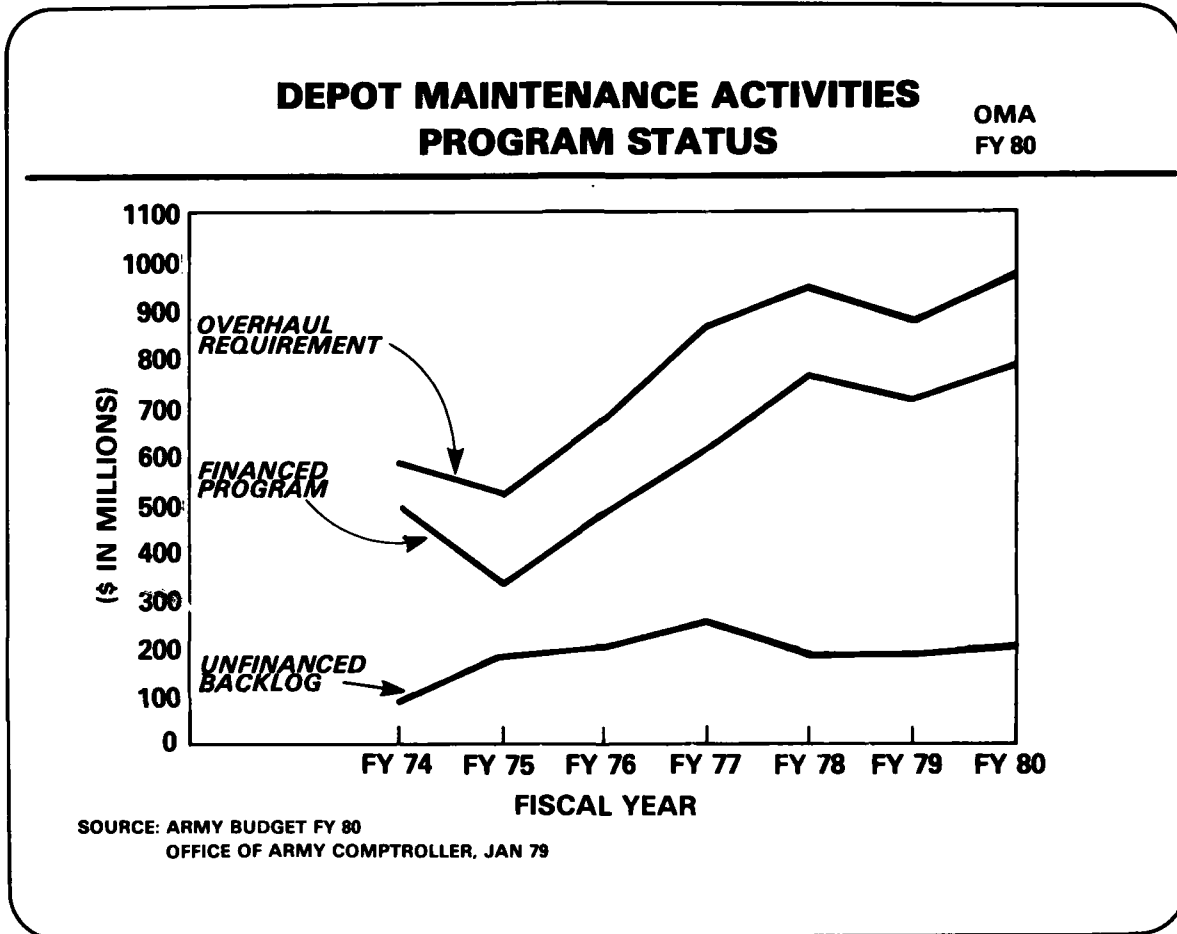

II-19

DEPOT MAINTENANCE CONTRACTS

DARCOM has responded in part to the manpower cuts by contracting out significant workloads. Chart II-20 shows that our FY 78 contracts have almost doubled since FY 75. We continue to seek ways to increase contracting out, but past experience teaches us that all commodities are not susceptible to this solution.

The decline between FY 78 contract awards and FY 79 planned contracts is directly attributable to DARCOM's budget reduction in the depot maintenance program.

Further, recall the manpower problem in central procurement—they also plan and execute depot level maintenance contracts. We find ourselves with inadequate personnel to perform in-house maintenance of prime equipment, while at the same time not having sufficient procurement people to make timely awards of commercial depot level maintenance contracts.

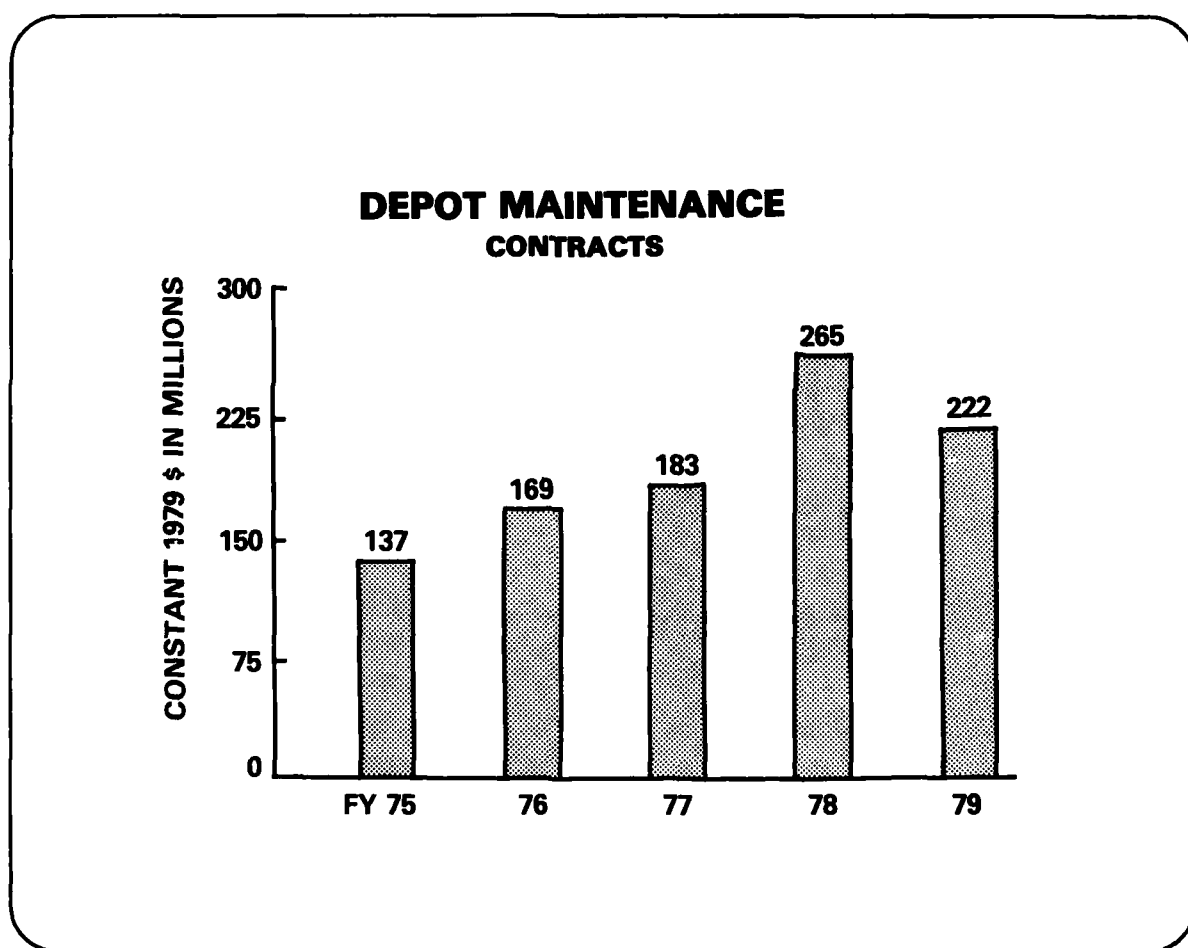

II-20

DEPOT MAINTENANCE—CARRYOVER vs. CEP

Due to overhire authority for FY 79 (grey area in Chart II-21), and increased FY 80 CEP, the situation in depot maintenance carryover appears to be improving. By end of FY 80, the carryover should be reduced to the management level. Recall, however, the unfinanced requirement (Chart II-19) remains and continuing personnel reductions jeopardize the current desirable status in depot maintenance.

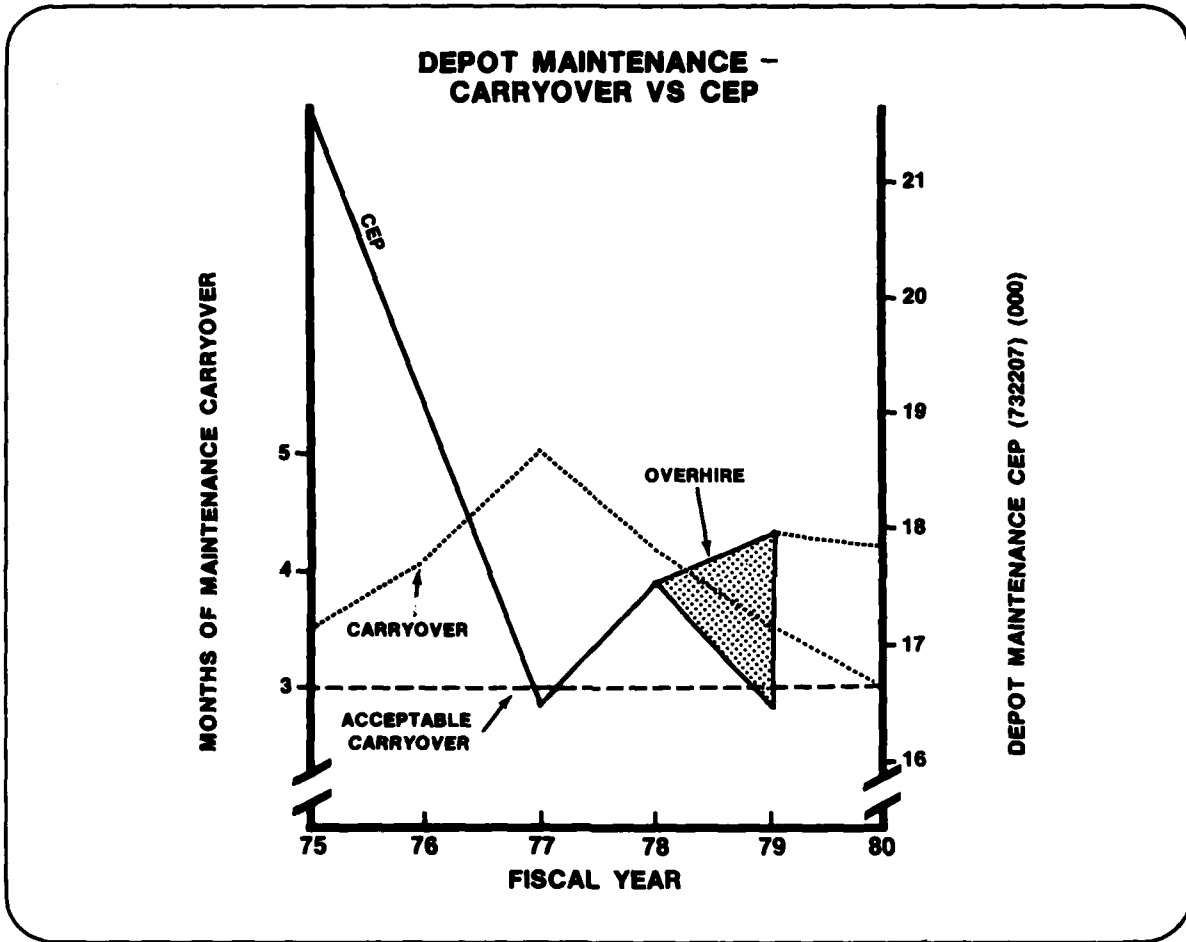

II-21

We'll look next at conventional ammo maintenance.

CONVENTIONAL AMMUNITION MAINTENANCE

Conventional ammunition maintenance involves the renovation and/or conversion/modification of ammunition that is not in an issuable condition.

The Army's present stockpile of issuable ammunition is inadequate to support requirements which would be generated by an active combat situation.

Because of the long lead time in the procurement process, and because of the high costs involved, a practical short term solution would be to insure that the current supply of ammunition is upgraded to a usable condition. This chart shows that an FY 79 expenditure of \$15 million (\$8 million currently financed) would be a wise investment.

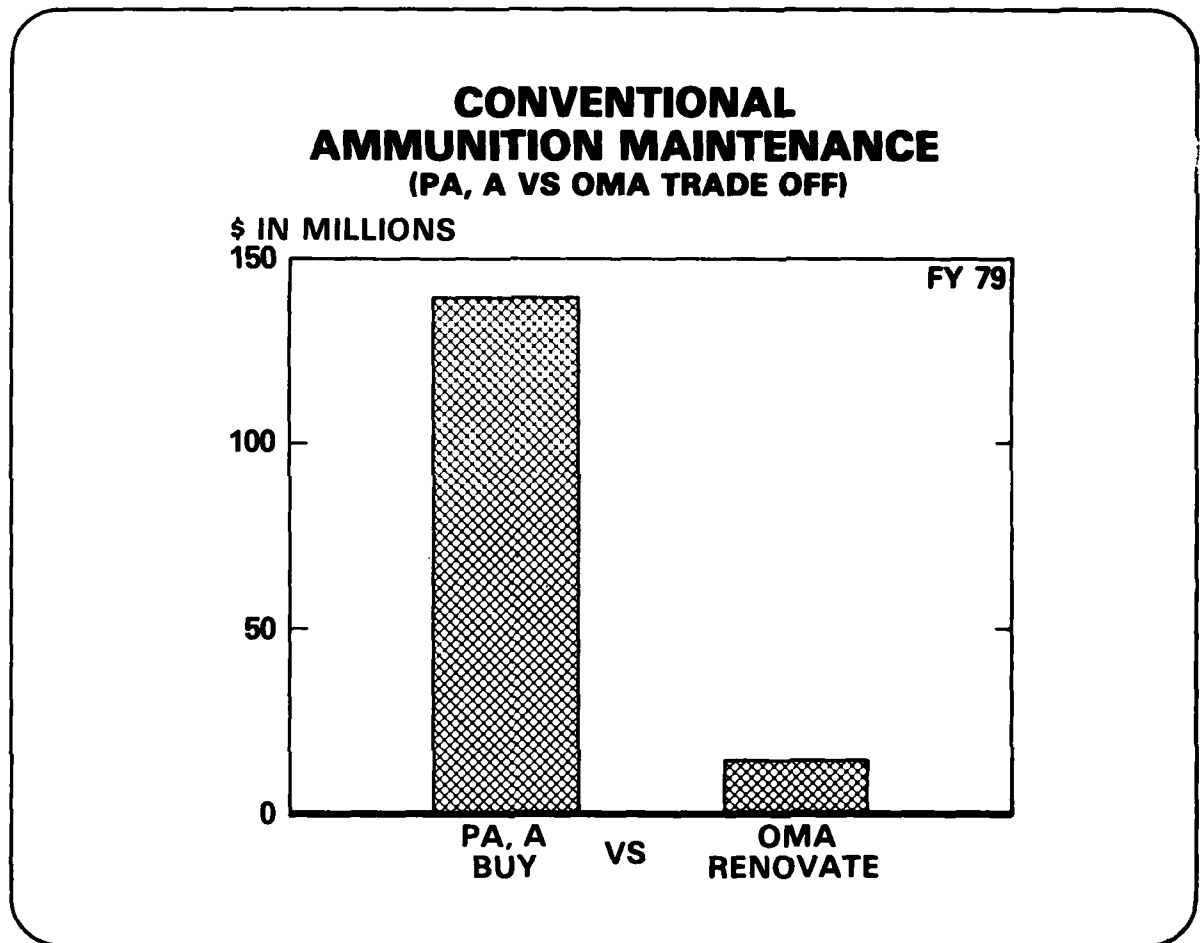

II-22

CONVENTIONAL AMMUNITION MAINTENANCE BACKLOG PROJECTION

The Army currently has 317,000 short tons of its inventory in an unserviceable condition. Of this amount, 142,000 is Code F (major renovation) for which there are current requirements. (Chart II-23).

Each year an additional 40,600 short tons reaches Code F condition. At the current level of funding and manpower, the backlog will continue to grow. By FY 1985, the backlog of Code F unserviceables for which there are requirements will have grown to 210,000 short tons (9% of the current Army inventory).

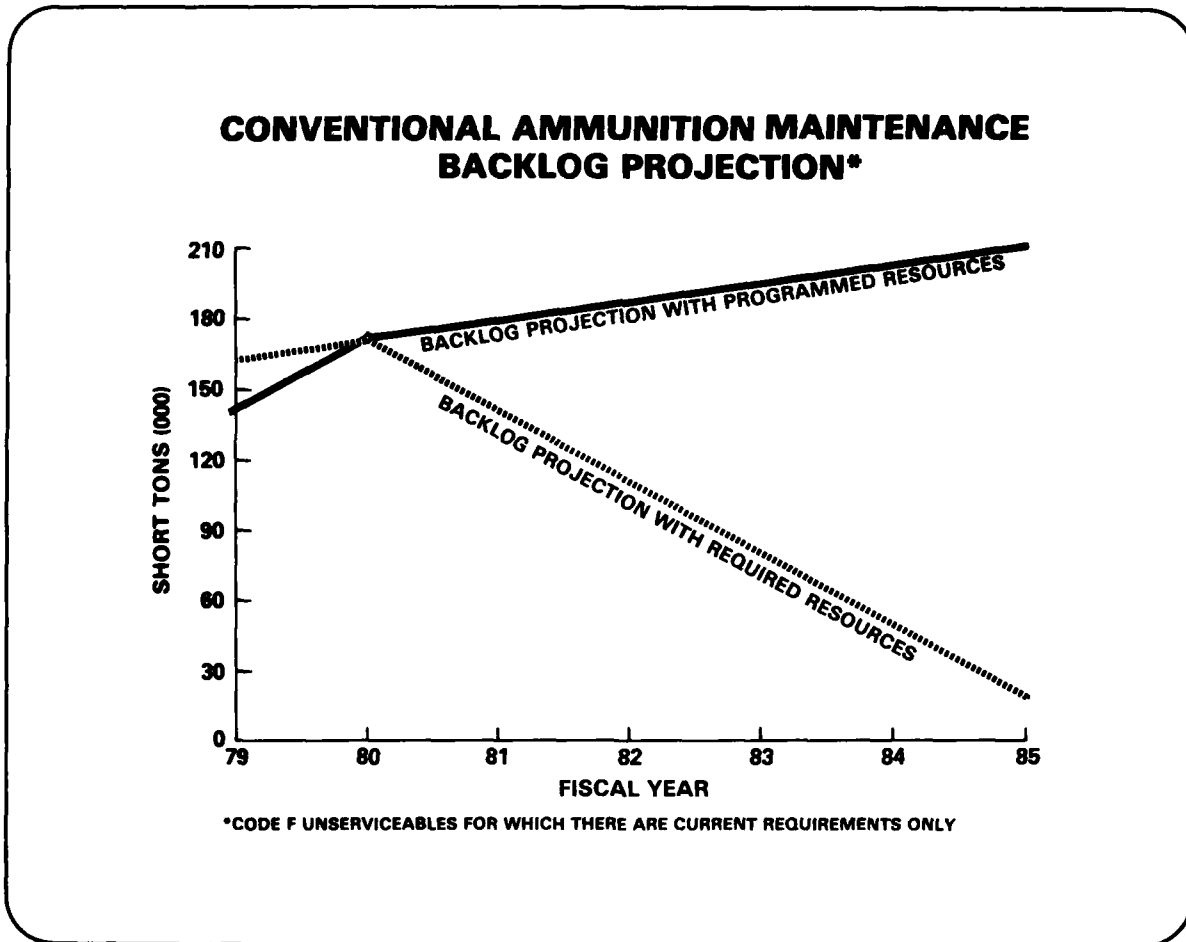

II-23

If required resources, Chart II-24, are provided, over \$1 billion in Army assets will be returned to serviceable condition by FY 1985 and the backlog will have been reduced to a management level.

CONVENTIONAL AMMUNITION MAINTENANCE

In order to reduce the backlog to a management level (Chart II-23) resources shown on Chart II-24 are required. DARCOM's current in-house capability to perform ammunition maintenance is approximately \$9 million per year. The remaining \$22 million must be performed at GOCO ammunition plants and by private contractors. A firm commitment to fund this ambitious program through FY 85 is required due to long lead time in the development, engineering, and production of ammunition peculiar equipment (APE).

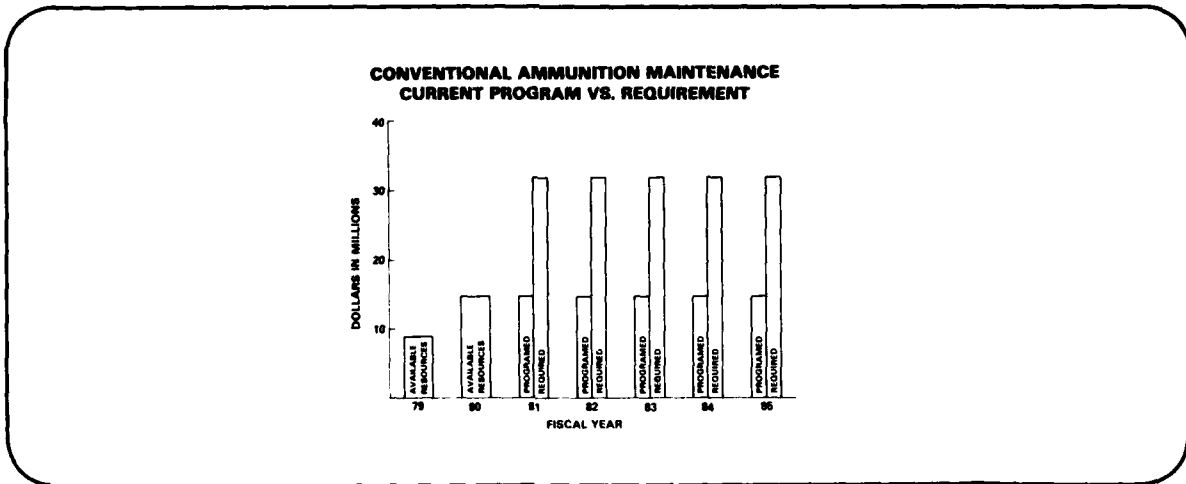

II-24

Army assets are only part of the ammunition problem.

UNISSUABLE STOCKS AT FORMER NAVY DEPOTS

The Army as Single Manager for Conventional Ammunition has responsibility for ammunition stocks at former Navy depots (Crane, McAlester, and Hawthorne). The estimate shown at Chart II-24A is a conservative best guess. \$10.9 million is currently pending in the FY 79 supplemental appropriation request to accomplish a comprehensive inventory and condition coding of this ammunition. Until that effort is funded and accomplished, it is impossible to predict the cost to renovate the backlog or estimate the annual generations of unserviceables. Once identified, the requirements are to be funded by Department of Navy.

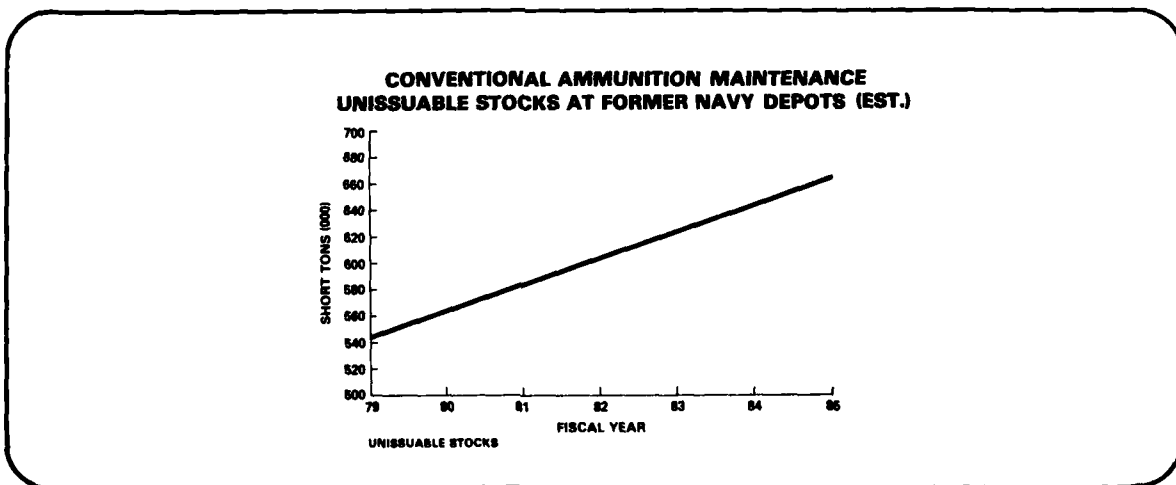

II-24A

We will next review the base operations resources necessary to support the mission elements of DARCOM.

MISSION vs. BASE OPERATIONS RESOURCES

As DARCOM's mission funding increases, so should the base operations resources increase—though not as a straight line function. The reverse was the case during the FY 75-77 period (Chart II-25). Since FY 77, both base operations funding and personnel have leveled out, yet mission dollars continue to increase.

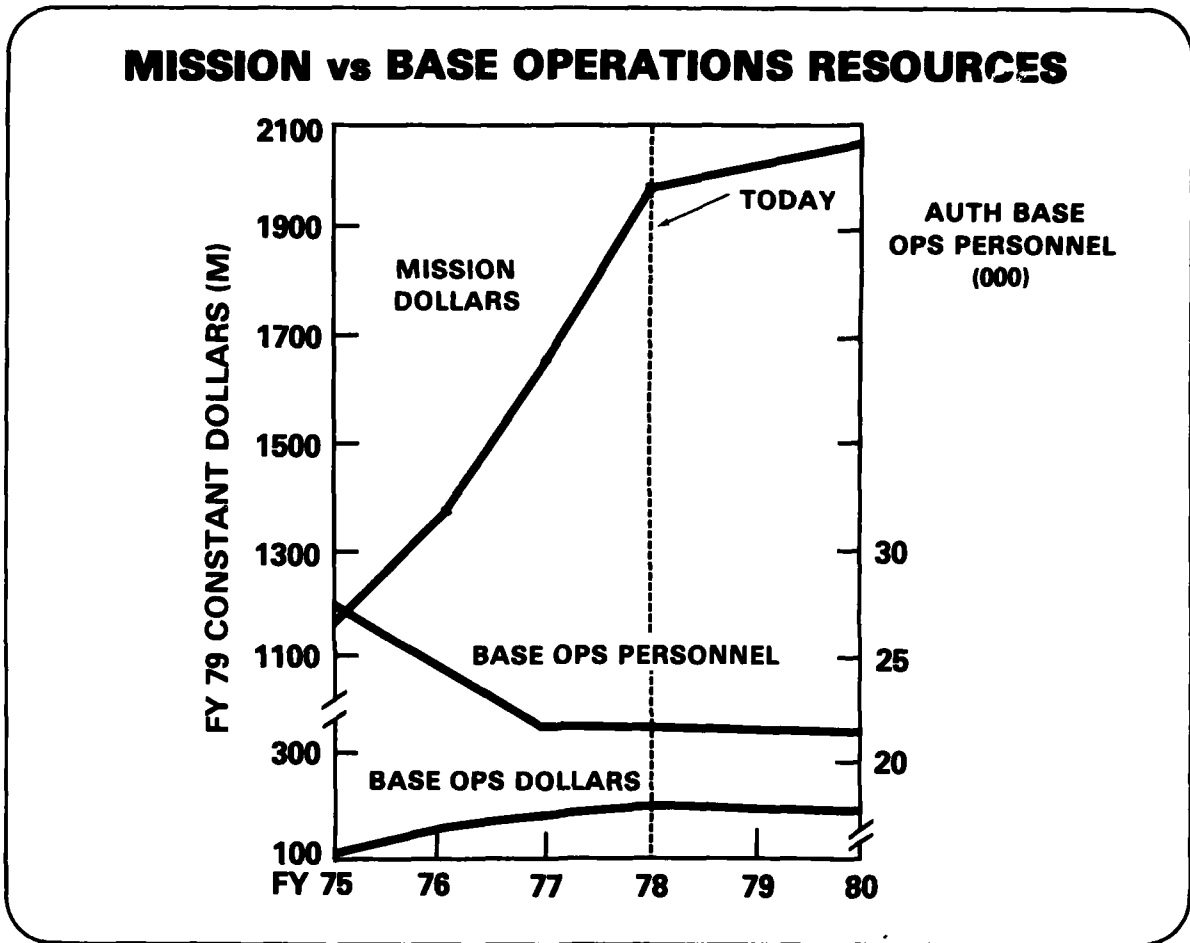

II-25

The fixed nature of certain base ops functions has been taken into account, but that portion which varies with mission has not been supported. Consequently, deferred maintenance, a measure of the shortfall, has significantly increased as shown next.

BASE OPERATIONS DEFERRED MAINTENANCE

Displayed in the shaded area on Chart II-26 is the deferred base operations maintenance—that work which we have been unable to accomplish because of the manpower/funding shortfall since FY 74.

This trend must be arrested if we are to adequately protect our \$125 billion real property investment cost.

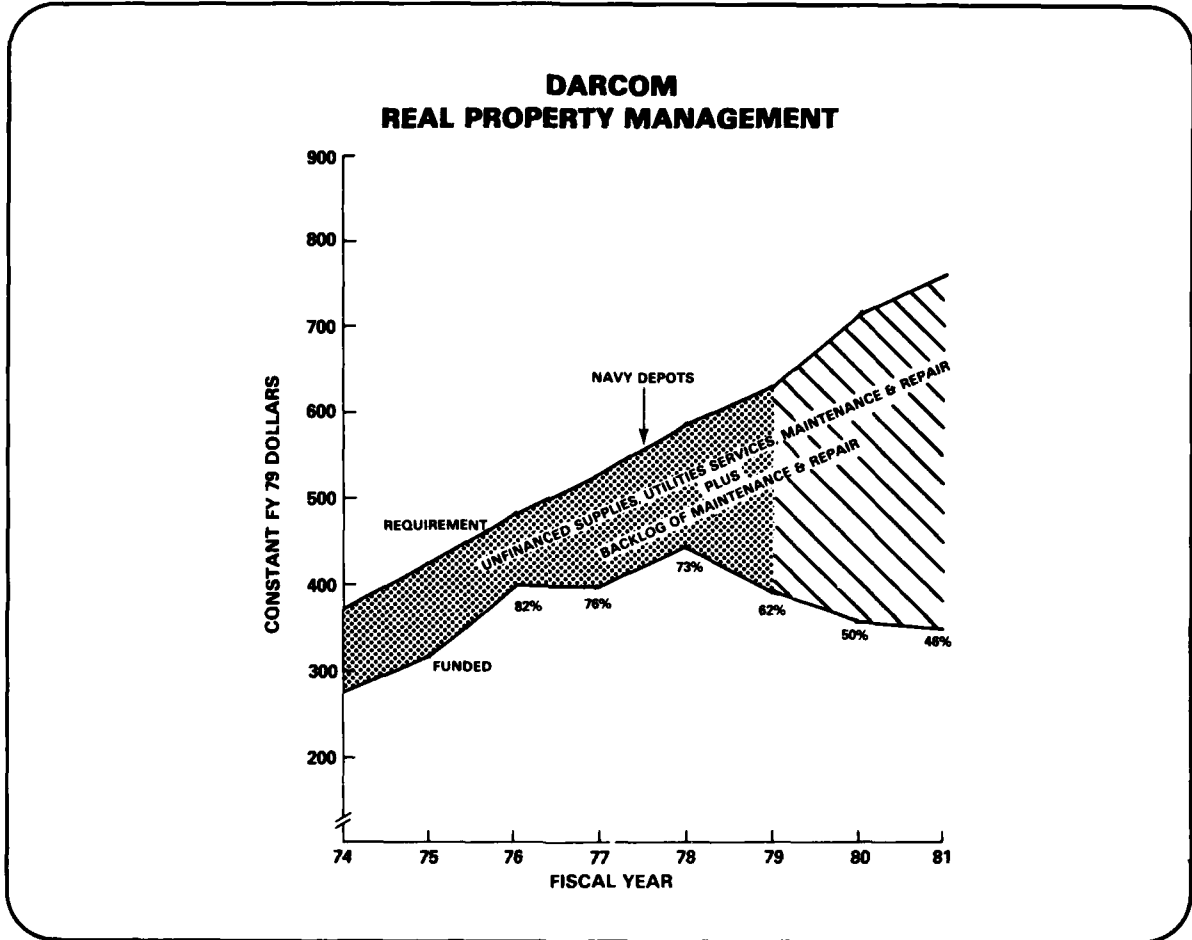

II-26

We move now to Section III—which examines the materiel development mission of DARCOM.

RESEARCH—DEVELOPMENT—TEST AND EVALUATION

Section III addresses Mid-Term Modernization and DARCOM's responsibilities in Materiel Development.

The functions that make up that portion of our Mission are displayed on Chart III-1: Research; Development; Test and Evaluation—all in support of the materiel acquisition process.

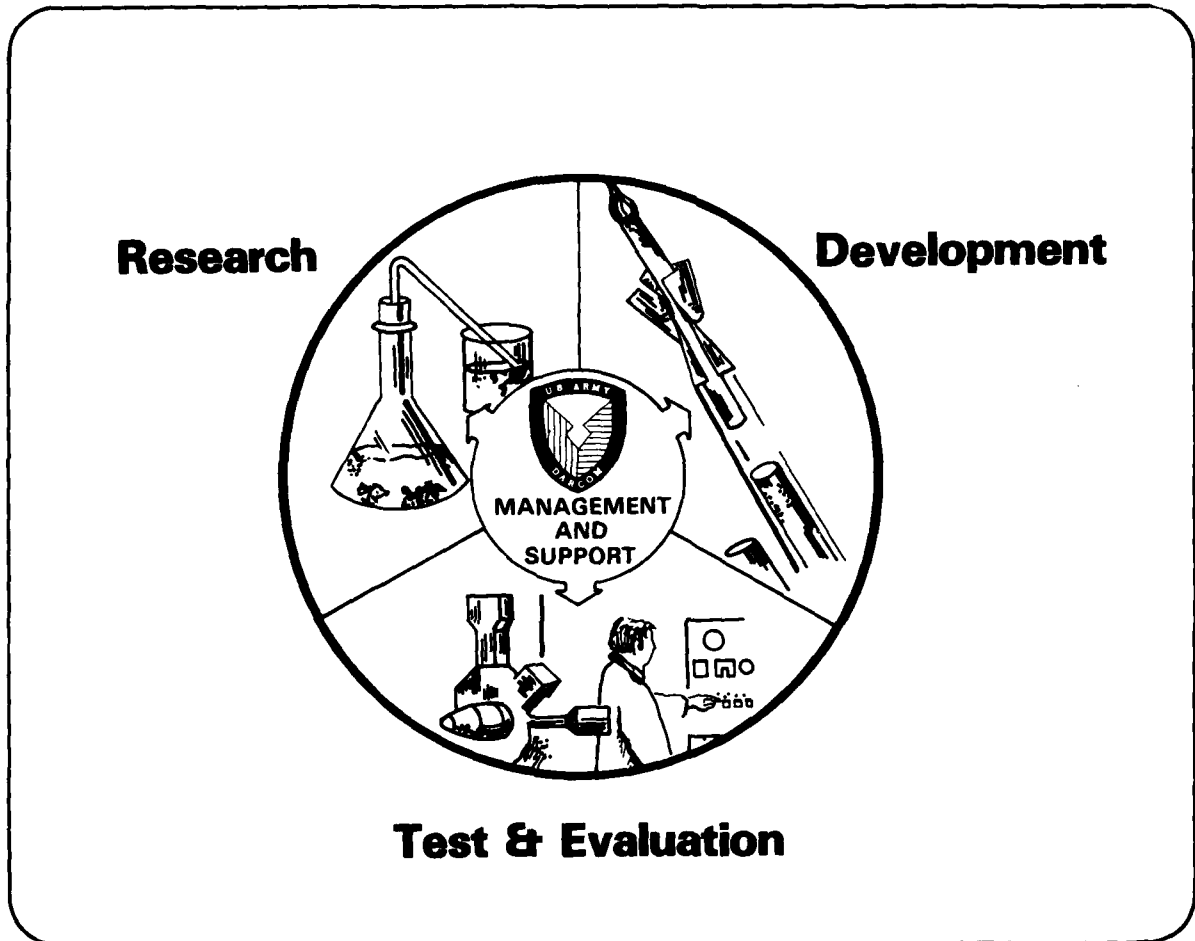

III-1

RDTE TRENDS

Similar to the manpower trend charts displayed earlier in this analysis, the DARCOM RDTE community has been in a steadily declining posture from the early years of the Vietnam War (Chart III-2).

Although the trend appears to have leveled out since 1975, the real decline has continued. The leveling occurred as a result of new missions and spaces being added.

At the same time that personnel resources are declining, the RDTE dollar line has been increasing at a rapid pace.

If programmed FY 80 authorizations do not change, some relief is in sight.

Our RDTE effort is driven in large part by the Threat. To keep this analysis unclassified, the Threat data has been excluded, but is available from DARCOM as a classified addendum.

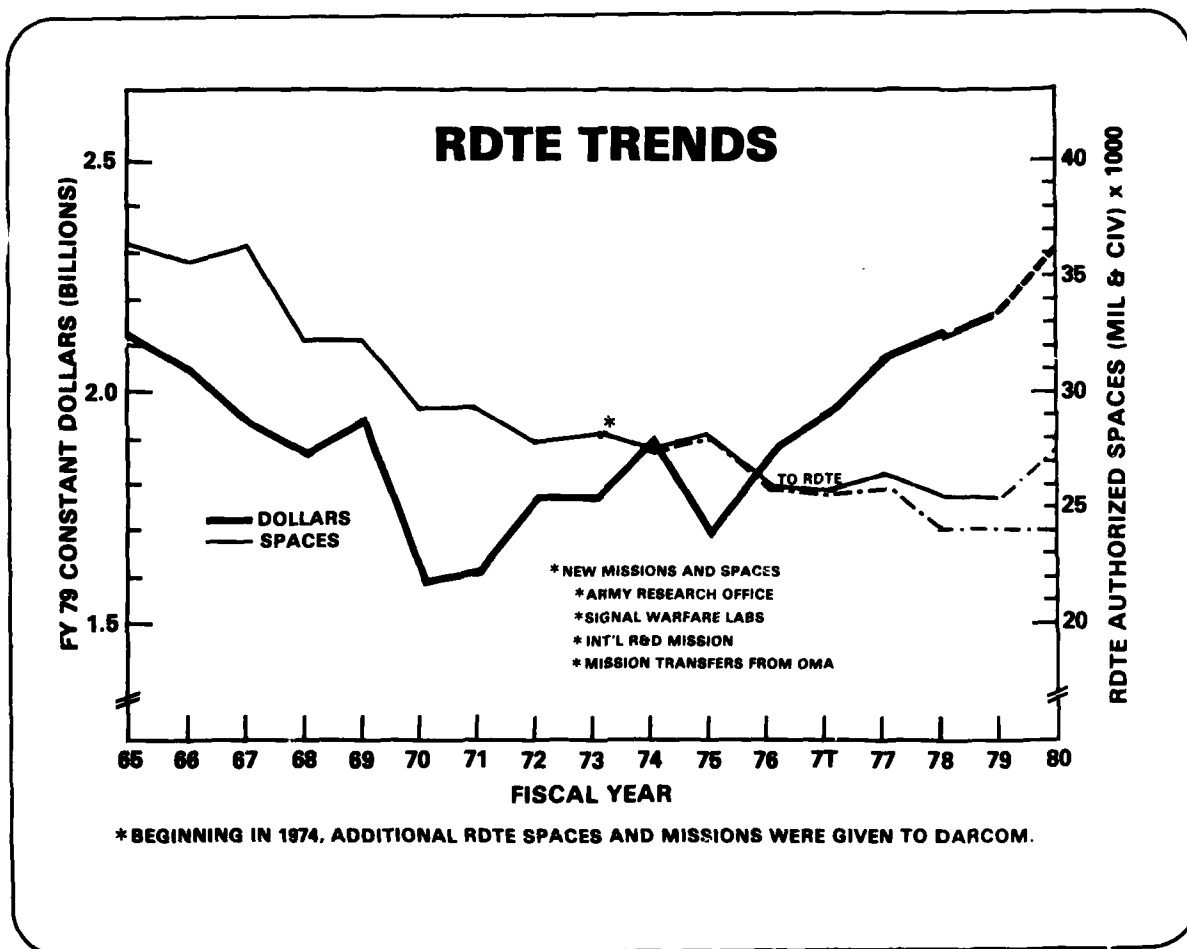

III-2

Our mid-term modernization takes place through product improvement (PI) and new development. We'll view first the PI program.

PRODUCT IMPROVEMENT PROGRAM GROWTH

The DARCOM Product Improvement Program (PIP) has increased dramatically since 1972 (Chart III-3).

The dollar value of the PIP has increased accordingly.

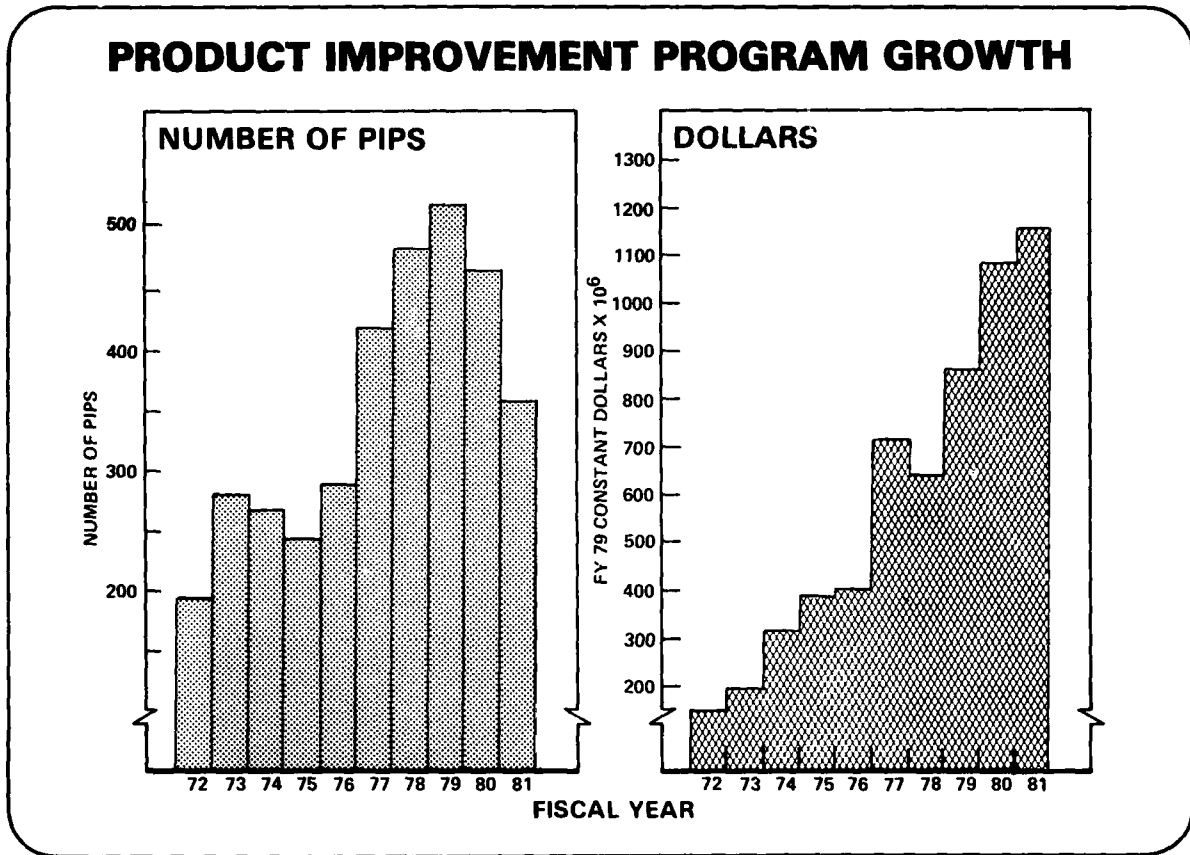

III-3

STRATIFICATION OF THE PI PROGRAM*

As Chart III-4 shows, the majority of the current PI's are concentrated in two areas:

- (1) Improvement of the equipment's operational capabilities, such as extended range, reduced vulnerability, increased firepower and improved fire control.
- (2) Improved RAM.

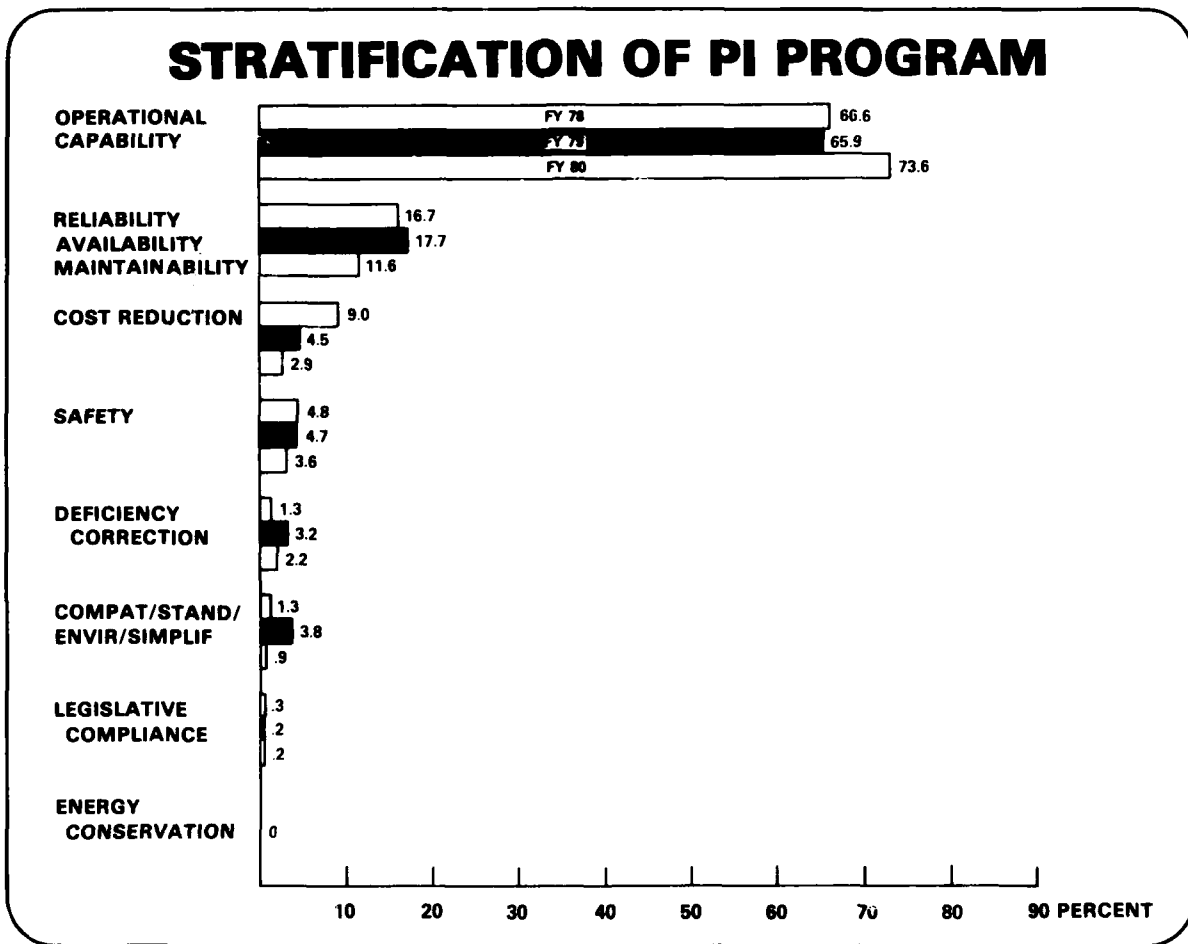

III-4

*To place the PI program in the proper perspective (in relation to the overall RDTE manpower decline), it should be understood that the PIP effort consumes only about 12% of the total RDTE funds and proportional numbers of direct labor Scientific and Engineering (S&E) manpower.

M60 SERIES MAJOR IMPROVEMENTS

Chart III-5 lists examples of PI's that have been applied to the M60 tank series.

M60 SERIES MAJOR IMPROVEMENTS

**TOP LOADING AIR CLEANER
ADD ON STABILIZATION
T-142 TRACK
RISE ENGINE
IMPROVED ELECTRICAL SYSTEM
M239 SMOKE GRENADE LAUNCHER
M240 MACHINE GUN
ENGINE SMOKE GENERATOR
LASER RANGE FINDER
SOLID STATE COMPUTER
TANK THERMAL SIGHT
M152MM GUN
DEEP WATER FORDING KIT**

III-5

TECHNOLOGY EXPLOSION

During the materiel development phase of the analysis, we focus our attention on the Threat and on opportunities emerging from the technical base. A real explosion occurred in the late 60's and early 70's as technology was pushed.

The technological growth in night vision equipment graphically illustrates an example of that explosion (Chart III-6).

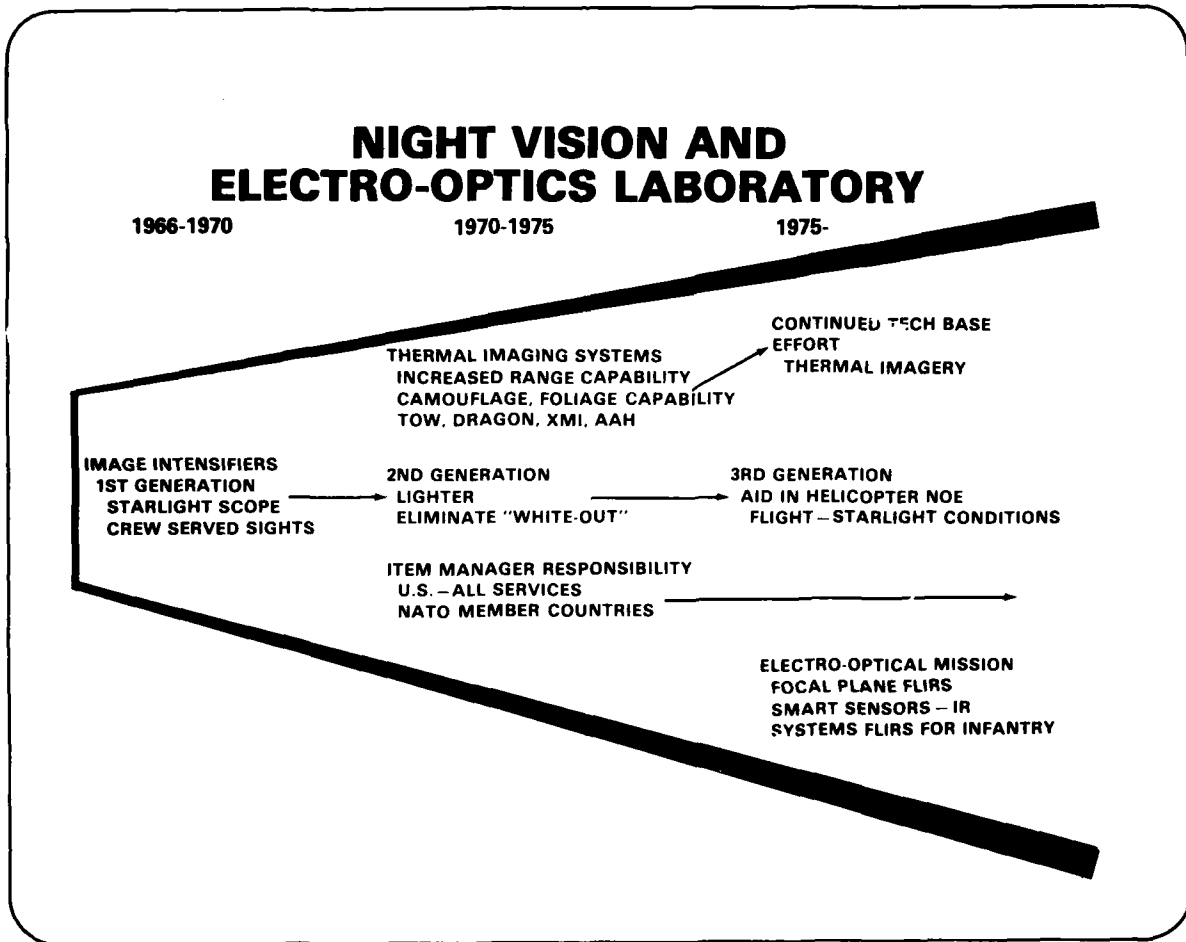

III-6

NIGHT VISION LABORATORY

Chart III-7 illustrates the consequent required growth of the Night Vision Laboratory (now Night Vision and Electro-Optics Laboratory) as technology expanded.

Today, with more emphasis being placed on the development and improvement of our night fighting and electro-optical capability we are faced with the paradox of steadily losing our dedicated manpower capability. The shrinkage in tech base personnel from 165 in 1971 to 120 today causes DARCOM great concern.

Even with the transfer of in-house technology to industry, without a reliable in-house capability we stand to lose ground in this key operational environment. We cannot depend on industry alone to make the effort necessary to push the state of the art.

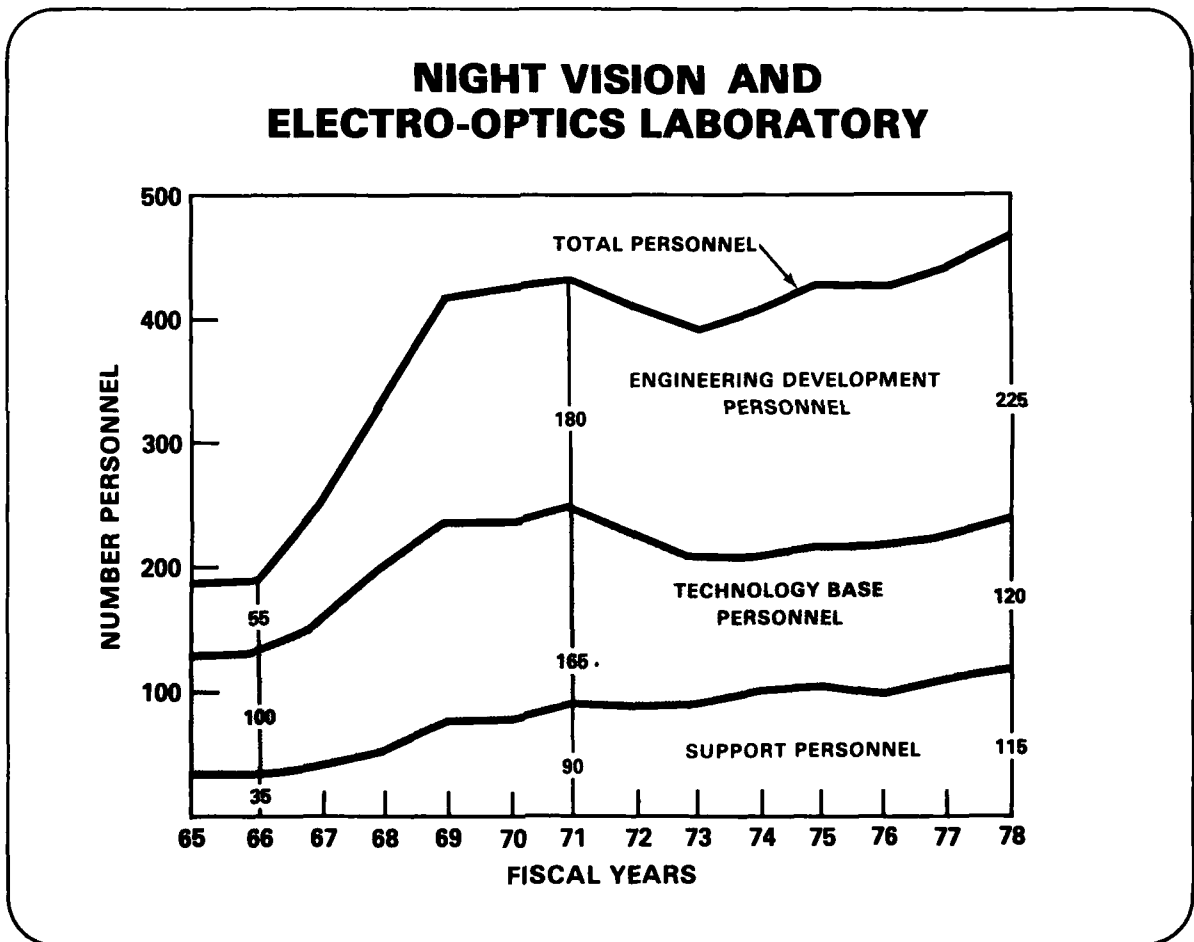

III-7

INCREASING MATERIEL SOPHISTICATION

Emerging from the Technology Explosion has been a sharp increase in weapon systems sophistication, which in turn, increases funding and manpower requirements.

Chart III-8 conceptualizes the difference in sophistication between the standard artillery 155mm HE round and the soon to be fielded Copperhead. While we are successfully meeting the objective of providing the Army with better firepower, we are doing so by consciously increasing the DARCOM RDTE workload, both quantitatively and qualitatively.

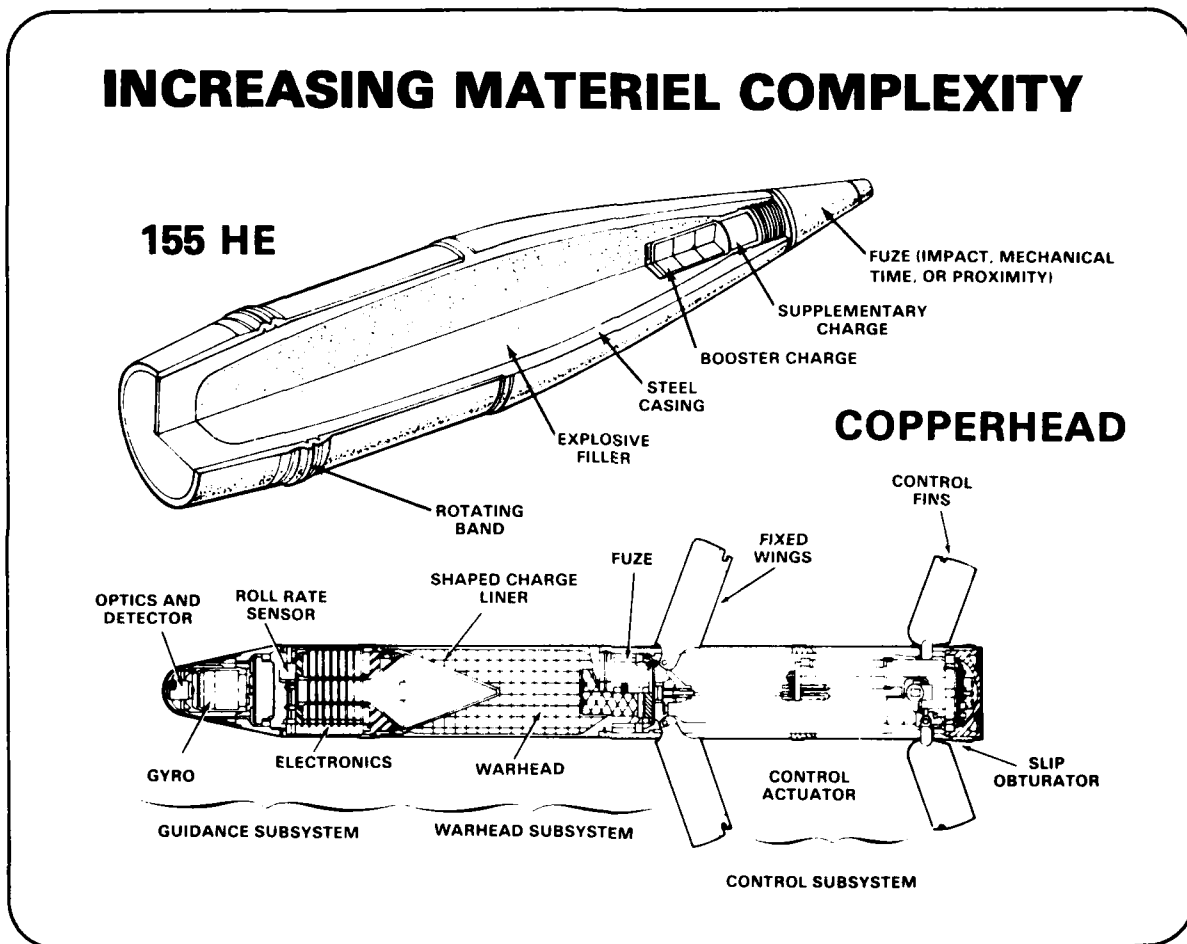

III-8

INCREASING MATERIEL SOPHISTICATION

The sophistication index shown on Chart III-9 was established by comparing the basic components of old and new systems. The numerical value was assigned through a Delphi (iterative) process using experienced scientists and engineers.

As illustrated on the previous chart, the Copperhead is a quantum jump ahead of the 1961 standard HE Round.

The XM-1 is significantly more advanced in survivability/vulnerability (armor improvement), fire power, fire control, range and mobility over the M60 series tank.

Likewise, the IFV has demonstrated increases over the M113 series in mobility, crew protection, and, most dramatically, in the huge firepower and fire control advances of the new weapon and weapon station.

A comparison of the AAH and the Cobra shows sharp increases in agility, survivability/vulnerability, firepower (HELLFIRE vs. TOW and 30mm dual purpose cannon vs. 20mm HE), and the Target Acquisition/Designator System and Pilot Night Vision system.

But all of these improvements, made possible through breakthroughs in our Technology Base, require a heavy investment in scientific and engineering manpower.

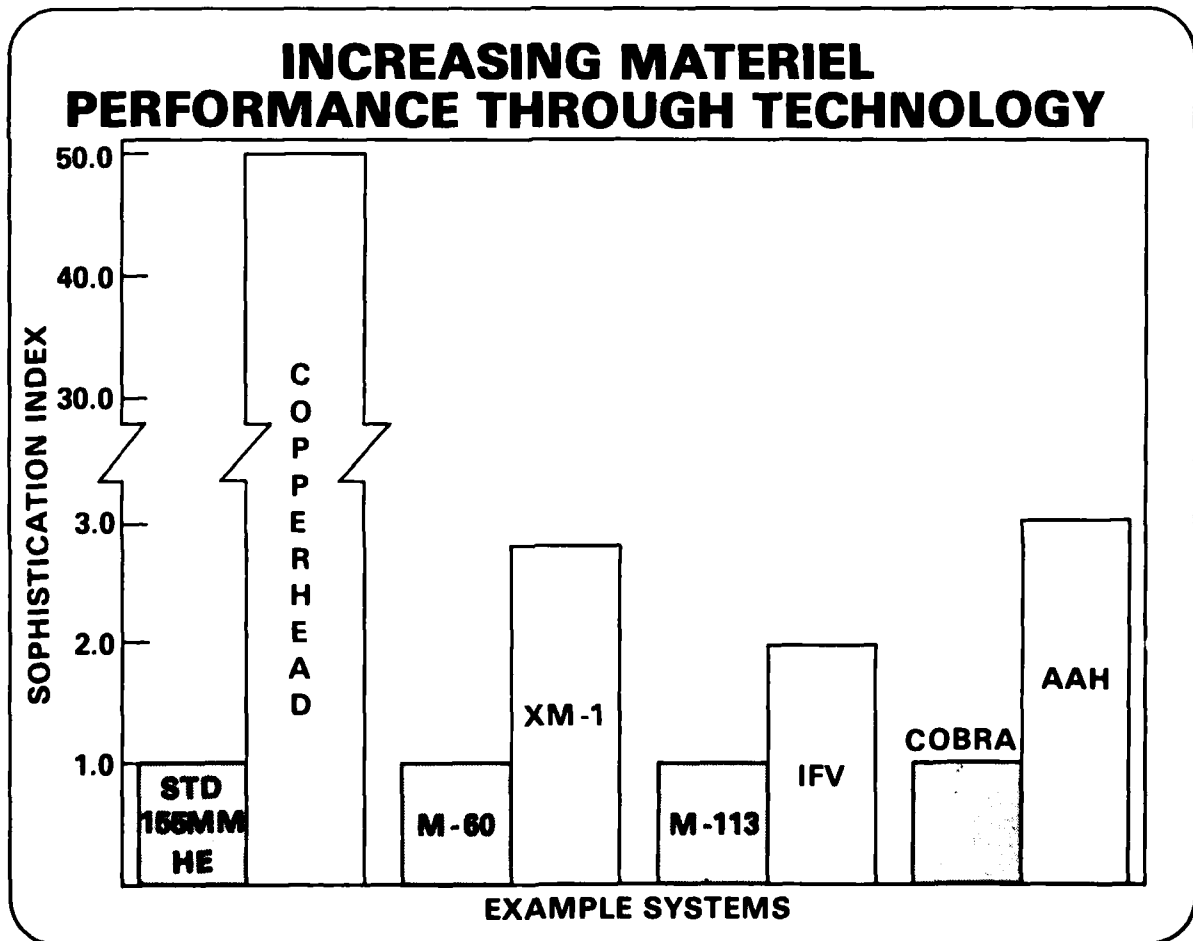

RDTE DOLLARS FOR TRAINING AIDS AND DEVICES

Because of the increased costs of prototypes, testing, and production hardware, we are investing more of our manpower and dollars in designing and developing training aids and devices (Chart III-10). Notice the percentage increases in the TRADE program in relation to the increase in total RDTE.

This trend will undoubtedly continue.

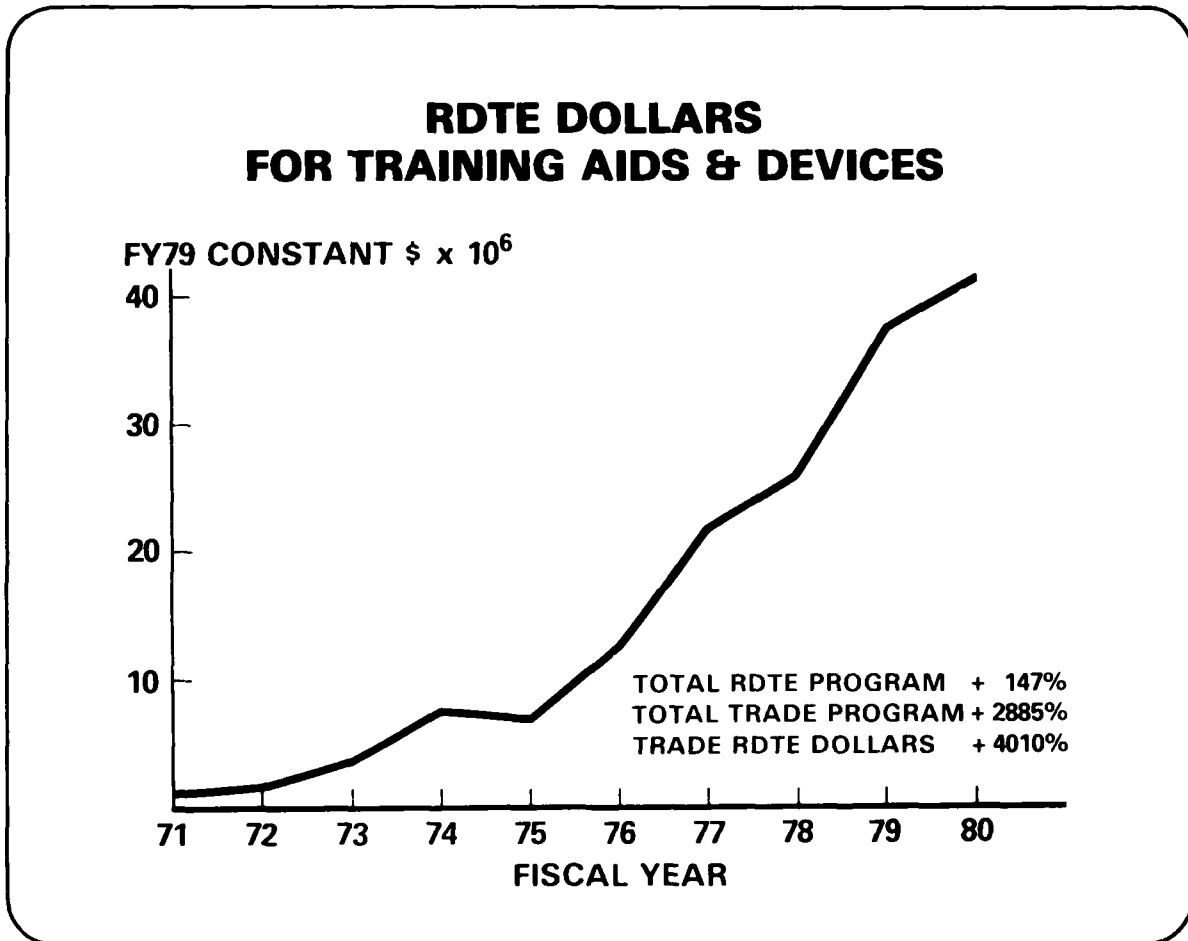

III-10

An example is shown next.

LASER DESIGNATOR WEAPON SYSTEM SIMULATION

Chart III-11 describes the laser designator simulation system developed by our Advanced Simulation Center at MIRADCOM, and its broad range of applicability.

LASER DESIGNATOR WEAPON SYSTEM SIMULATION

	<u>FY 77-FY 80</u>
SIMULATION COST	\$7M-\$9M PER YEAR
MIRADCOM CIV MY	45, 30 PER YEAR 79, 80
CONTRACTORS INVOLVED	15-20, 50 PER YEAR 79, 80
SYSTEM APPLICATIONS	COPPERHEAD, HELLFIRE, TAADS/AAH, GLLD, RPV's COEA's, INDEPENDENT EVALUATIONS, DESIGN AND TRADE-OFF ANALYSES TACTICS AND DOCTRINE STUDIES

III-11

Simulations, where appropriate, cut down test costs—and testing is our next topic.

TECOM MANPOWER TREND

As in other sectors of DARCOM, the manpower trends in testing are down and to the right (Chart III-12). The dramatic drop from FY 75 to FY 76 portrays the loss of the Test Boards.

Compounding this problem is the 6% increment of total FY 78 testing conducted at our major proving grounds in support of high priority non-Army programs such as the Cruise Missile.

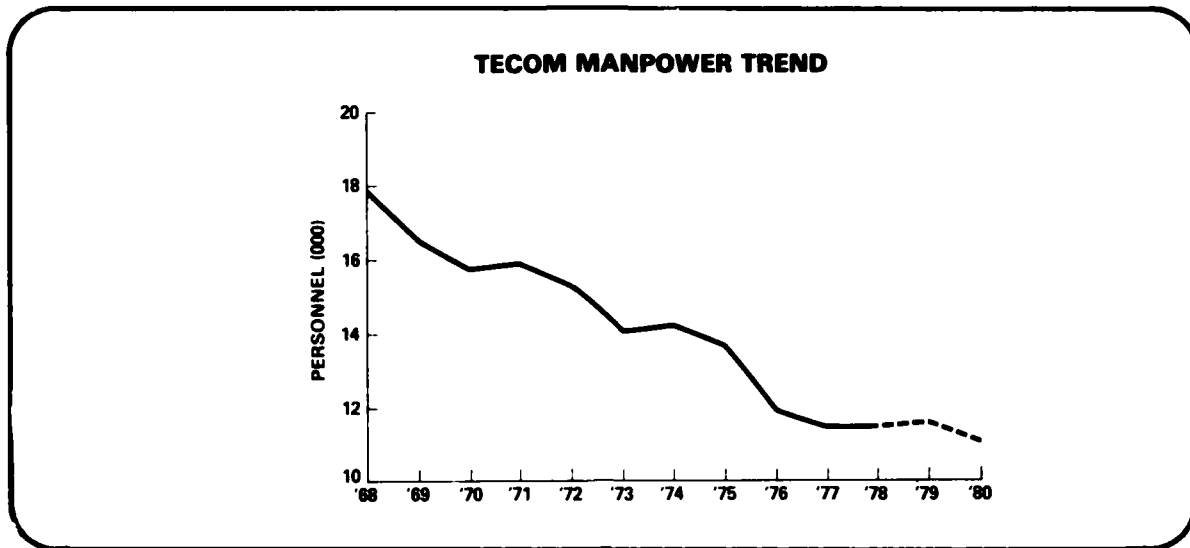

III-12

LOSS OF TECOM TEST BOARDS

The decision to transfer the Service Test Boards from DARCOM to TRADOC had secondary impacts that are highlighted on Chart III-13.

Of particular significance is the loss in flexibility—the ability to shift workload and resources as the dynamics of testing are encountered.

LOSS OF TECOM TEST BOARDS

- **PERSONNEL LOSS — 1060**
 - 23% REDUCTION IN DLMH AVAILABLE FOR TESTING
- **REDUCED TEST FLEXIBILITY**
 - ELIMINATED TRAINED AND RESPONSIVE CAPABILITY
 - LOSS OF SERVICE TEST CAPABILITY TO DEVELOPER
 - LOSS OF SERVICE AND ENGINEERING TEST INTEGRATION

III-13

INCREASED COMPLEXITY—TECOM TESTING

Recalling the increases in sophistication of our new systems, one will observe on Chart III-14 the attendant increase in direct labor manhours per test. Also plotted are the total available manhours. The reader should bear in mind that this is in addition to our greater reliance on simulation and training devices.

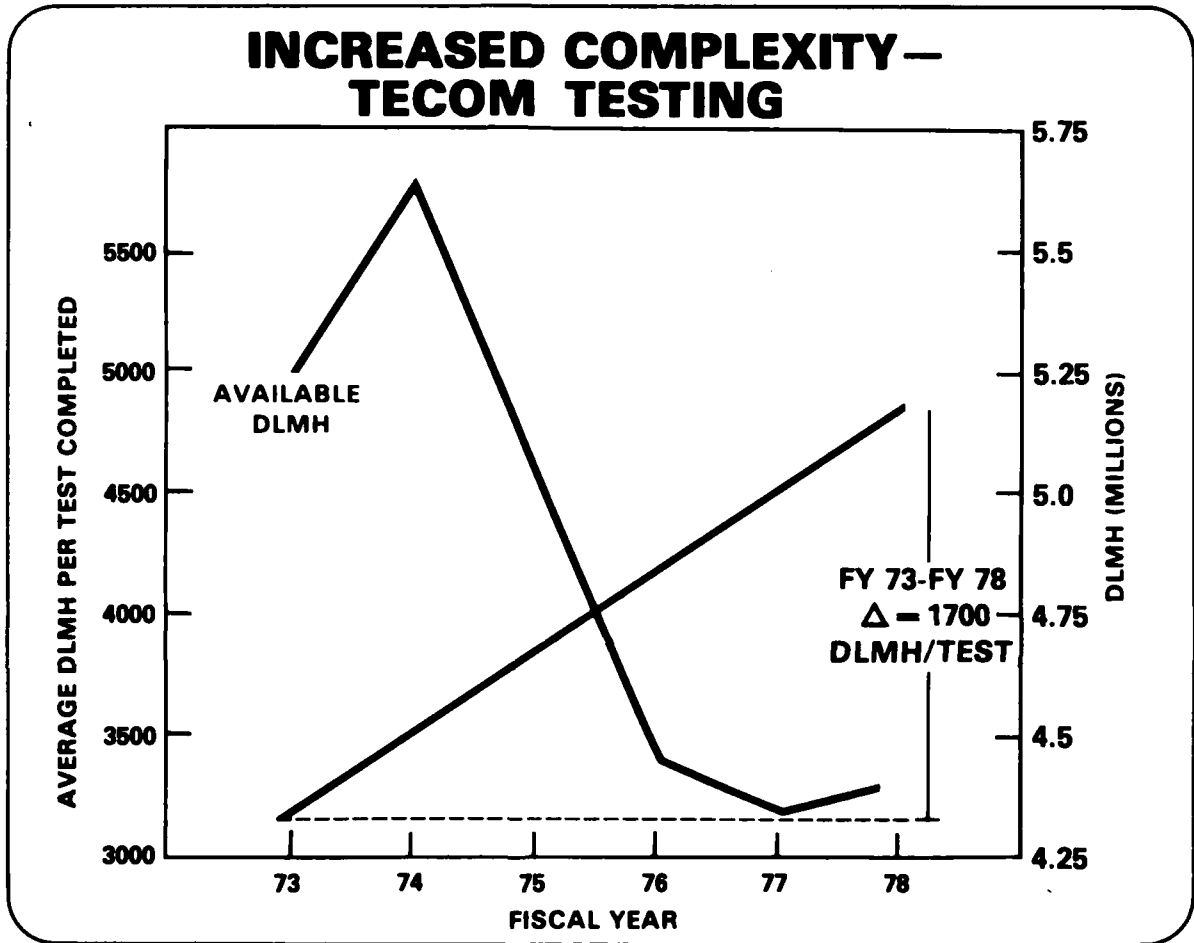

III-14

TECOM CONTRACT DOLLARS

To partially counter this trend, DARCOM has increased its contract test program (Chart III-15). It is well to remember, however, that not all testing is susceptible to contracting out—nor is contracting out desirable in many programs—We seek the proper balance.

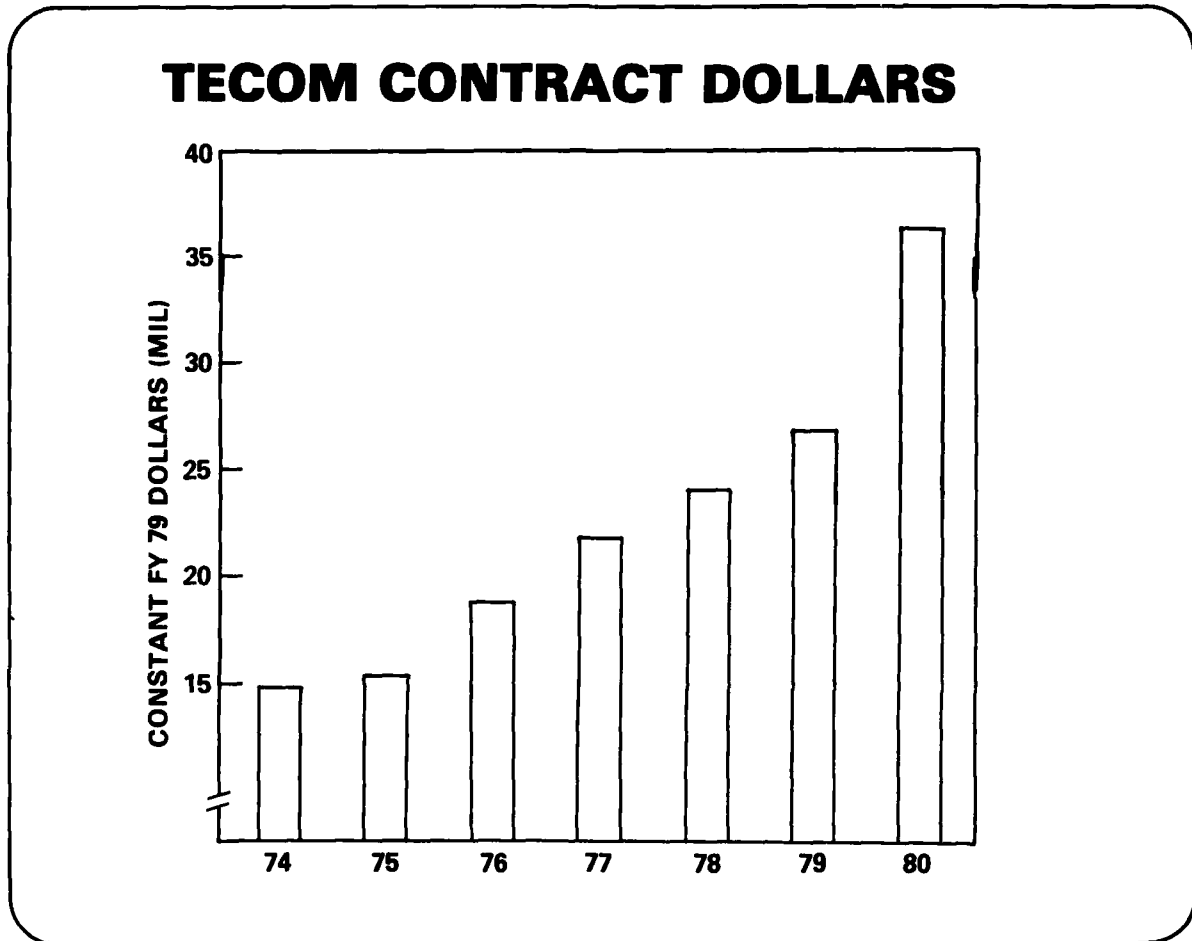

III-15

TECOM TEST WORKLOAD AND BACKLOG

The cumulative effect of these test trends, if uncorrected, will place TECOM in a position where only the most critical programs will be undertaken, presenting management with some very difficult decisions as to priorities.

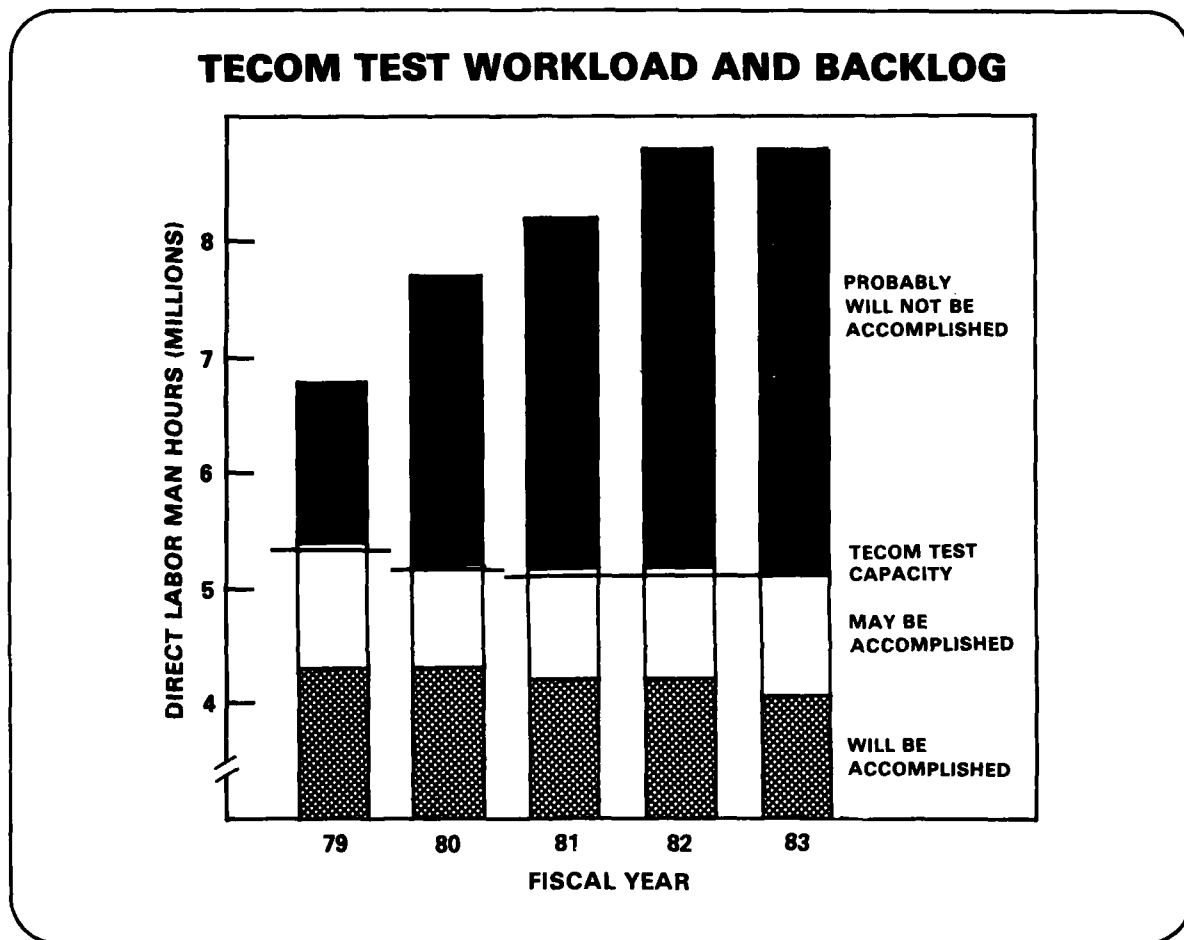

III-16

Management manpower for our major systems is our next topic.

DARCOM PROJECT MANAGER TRENDS

Since 1962, due to cost, technical complexity, and military importance of our major programs, the Army has adopted Project Management as a standard management form.

Chart III-17 shows the trend in number of development PM's and the relative size of PM offices.

Coincident with the pressures of the manpower squeeze, one observes that the number of PM's is growing, representing an additional, though necessary, drain on a shrinking development base. The average size of PM offices is, of necessity, shrinking.

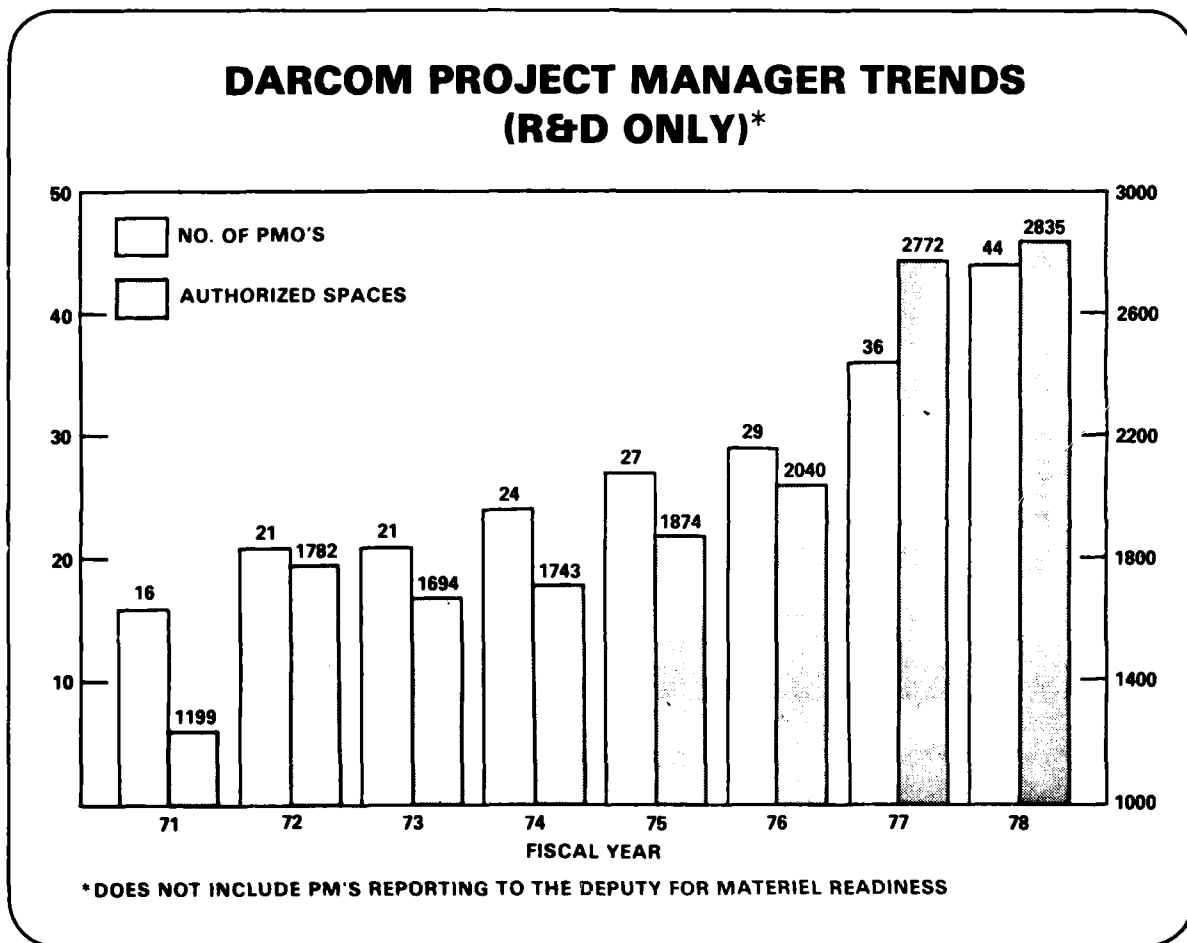

III-17

Chart III-18 depicts the growing number of PM's in the missile business.

MICOM/MIRADCOM PMO TRENDS

Note that in the early 60's there were very few PM's, but with large offices—also remember the size of AMC in the early 60's.

The ratio changed in the mid 70's as PM's, after a cutback in the early 70's, rose in number, but with smaller offices—the net effect being the purchase of more services from laboratories and other command in-house personnel.

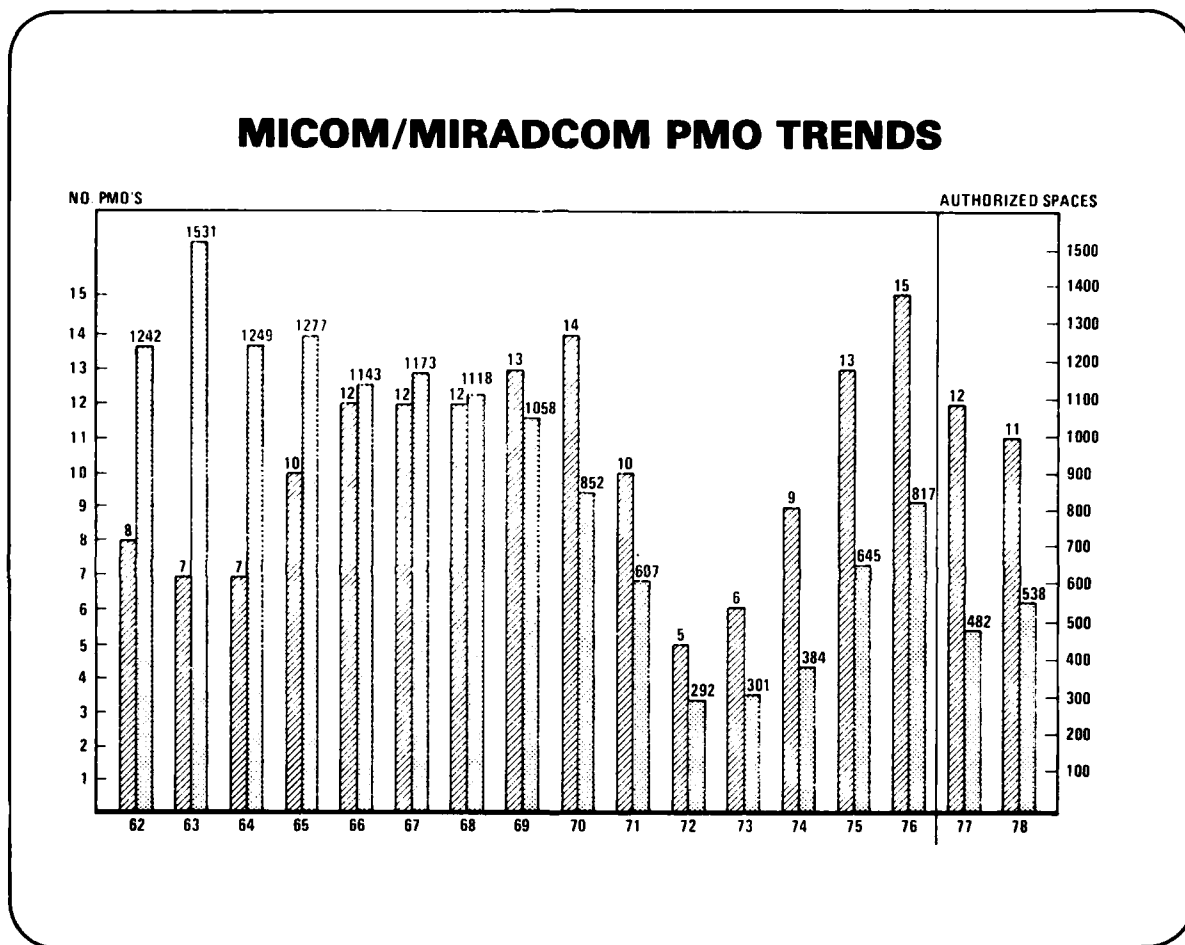

III-18

Having described manpower trends, increased sophistication, a pronounced shift to simulation and training devices, the critical shortage of test resources, the growth in PM activity and a corresponding increase in lab/functional personnel devoted to this activity, we will review next the overall manpower picture.

DISTRIBUTION OF RDTE PERSONNEL

Chart III-19 depicts the trend in RDTE technical and support personnel.

While the trend in technical personnel levels off in the FY 78-80 period, after a 17.1% drop, support personnel are increasing during this time-frame. This phenomenon is consistent with the shift to out-of-house contracting which drives up the number of technical and support people required to assist contracting personnel during negotiation and to administer and monitor the contracts—but also results in a corresponding reduction in technical personnel available for employment on in-house R&D.

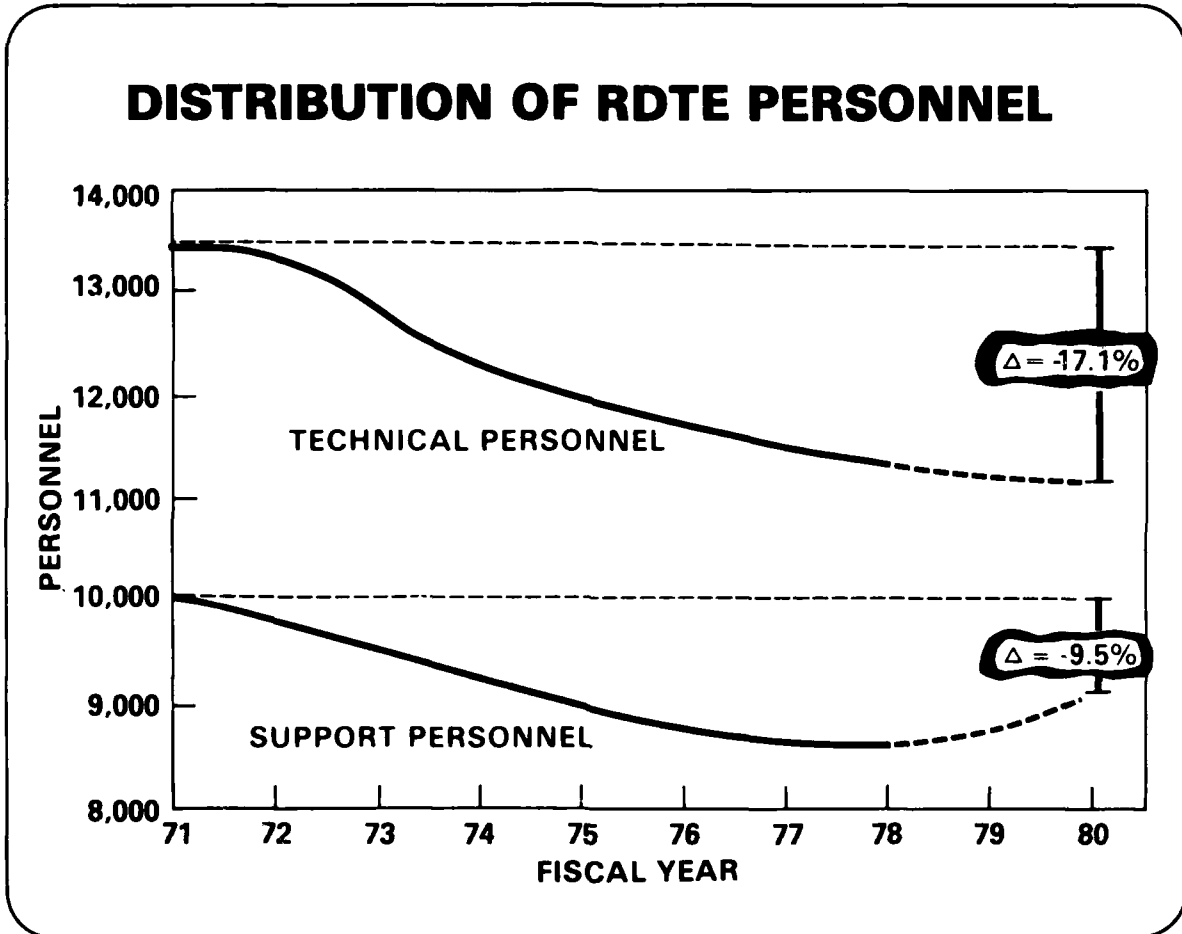

III-19

RDTE EXPENDITURES: CONTRACT & IN-HOUSE

Chart III-20 reinforces the trends displayed on the previous chart.

Though the total program has increased 147%, in-house work has decreased by 49%.

Of particular concern is the impact on our in-house Technical Base.

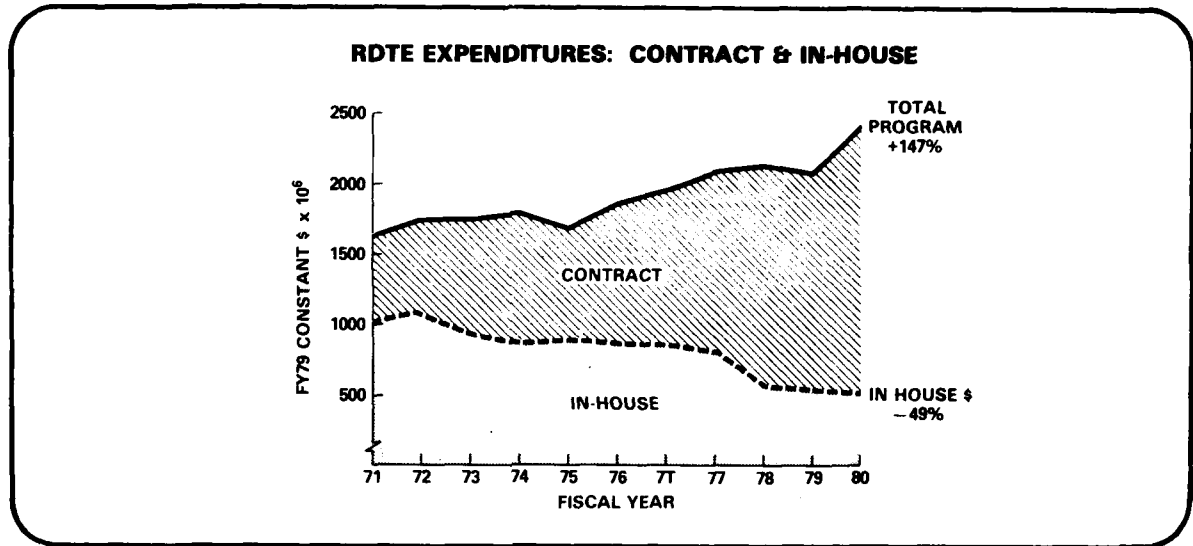

III-20

TECHNOLOGY BASE EXPENDITURES IN-HOUSE AND CONTRACT

Chart III-21 confirms the trend to more contracting out of our technology base program. Though there is no DA established optimum ratio, our current in-house/contract ratio is 50% to 50%.

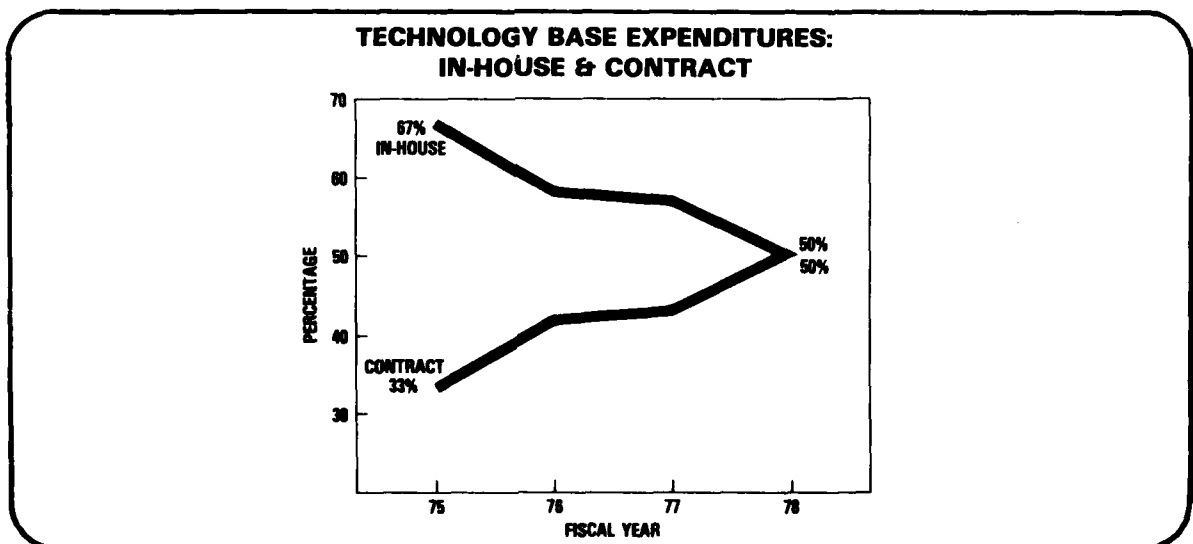

III-21

TOTAL TECHNICAL SPACES

Technical support to PM's, contracts/contractors, development/production engineering, and to other non-laboratory efforts, in combination with a decrease in scientific and engineering personnel, has reduced the population of technical personnel working in our laboratories and devoted to pushing technology. This undesirable squeeze will result in 19% fewer technical laboratory personnel dedicated to the tech base in 1980 (Chart III-22).

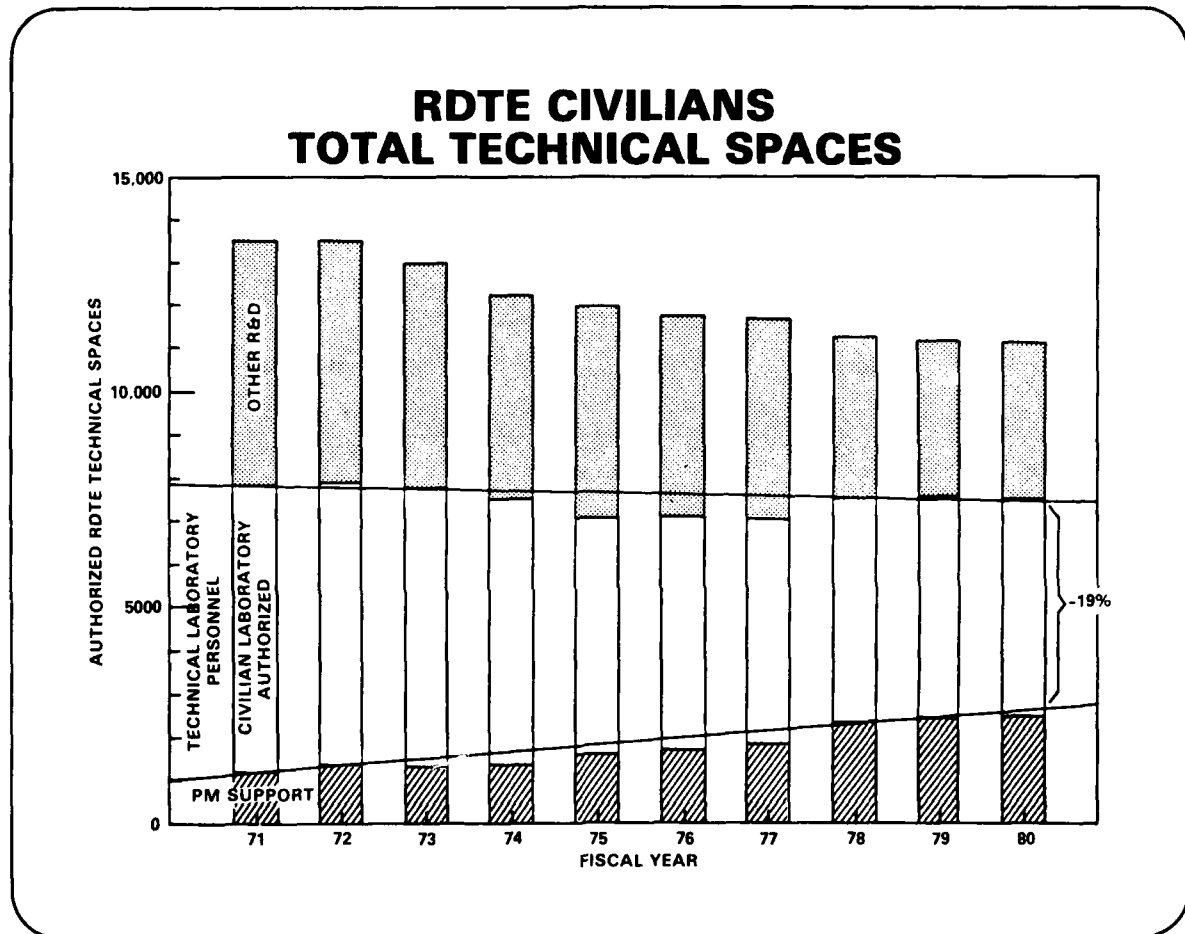

III-22

RDTE TECHNICAL EFFORT

Chart III 23 graphically summarizes the three preceding charts. The fact is that we are losing our in-house capability to advance technology. This is a very dangerous position, particularly when viewing the advances being made by the Soviets.

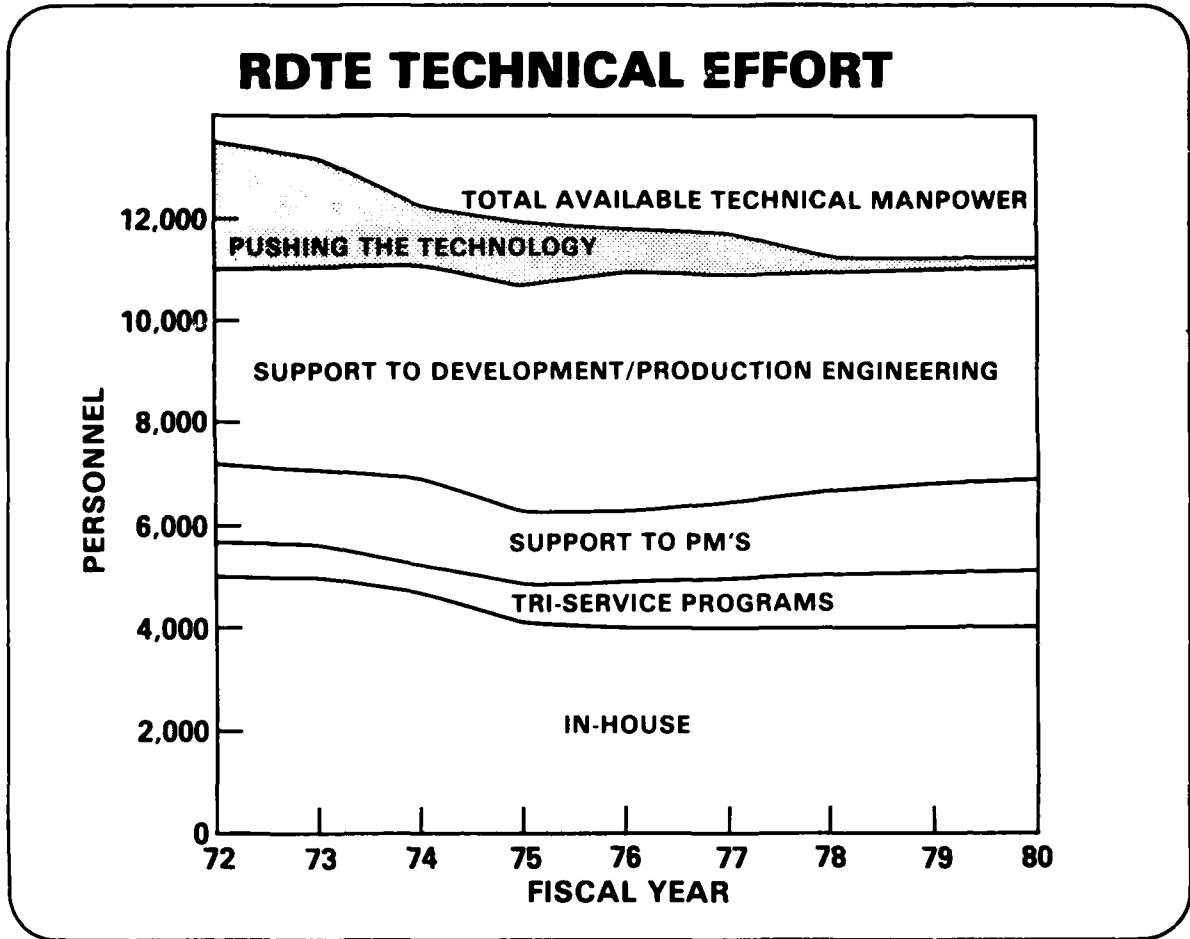

III-23

Section III concludes with an examination of other factors influencing our materiel development personnel posture.

THE SALARY GAP

A key factor in maintaining a productive and imaginative technical workforce is the ability to attract young, talented, and innovative personnel. Chart III-24 shows the divergence, starting in 1974, in beginning salaries for scientists and engineers in government and industry. Note that the industry figures are average starting salaries while the government figures are for the more talented graduates (top 25% of class or grade point better than 3.0 on a 4.0 scale).

This divergence will continue to increase as pay caps are placed on government salaries.

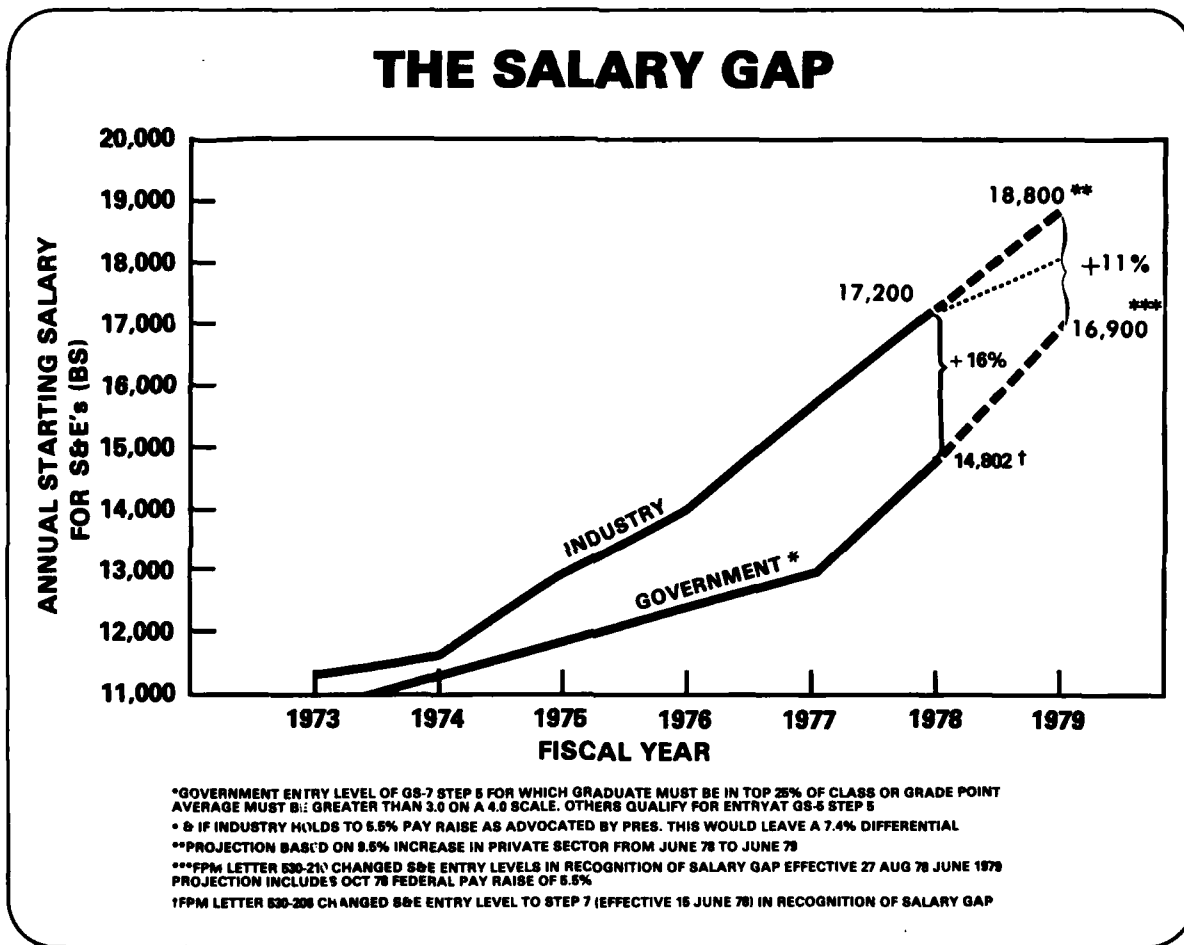

III-24

S&E'S LEAVING FOR NON-DARCOM JOBS

In 1977, over 450 scientists and engineers left the DARCOM technical staff for positions in universities, private industry, or other government agencies (Chart III-25).

More than half of those scientists and engineers who left DARCOM in 1977 were in the grades of GS-11 and 12, which are the senior training and journeyman levels.

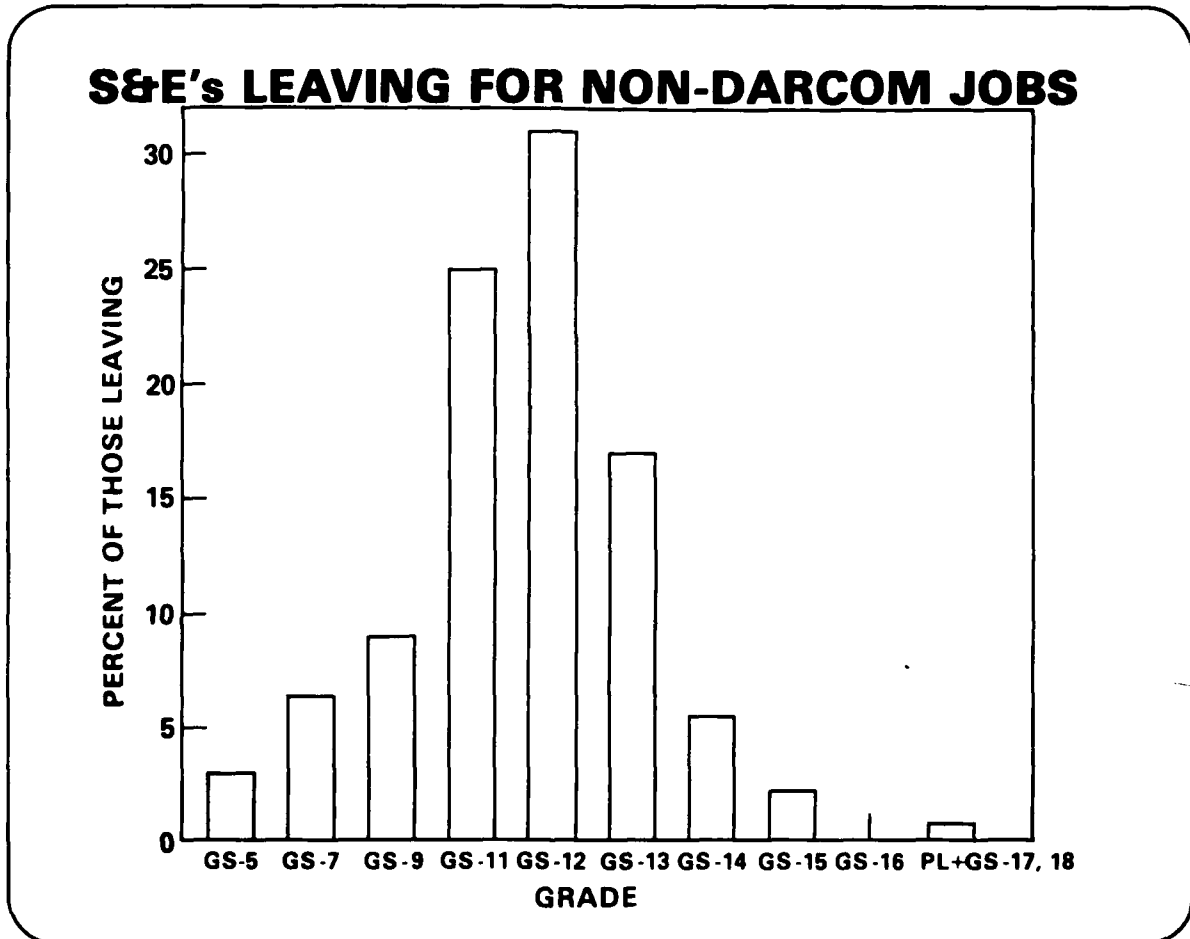

III-25

DISTRIBUTION OF S&E PERSONNEL BY GRADE

Our inability to compete with industry for young, talented scientists and engineers is confirmed on Chart III-26.

The actual DARCOM grade distribution differs markedly from the desired distribution (1973 was considered an acceptable distribution), particularly at the GS-5, 7, 9, and 11 grade levels.

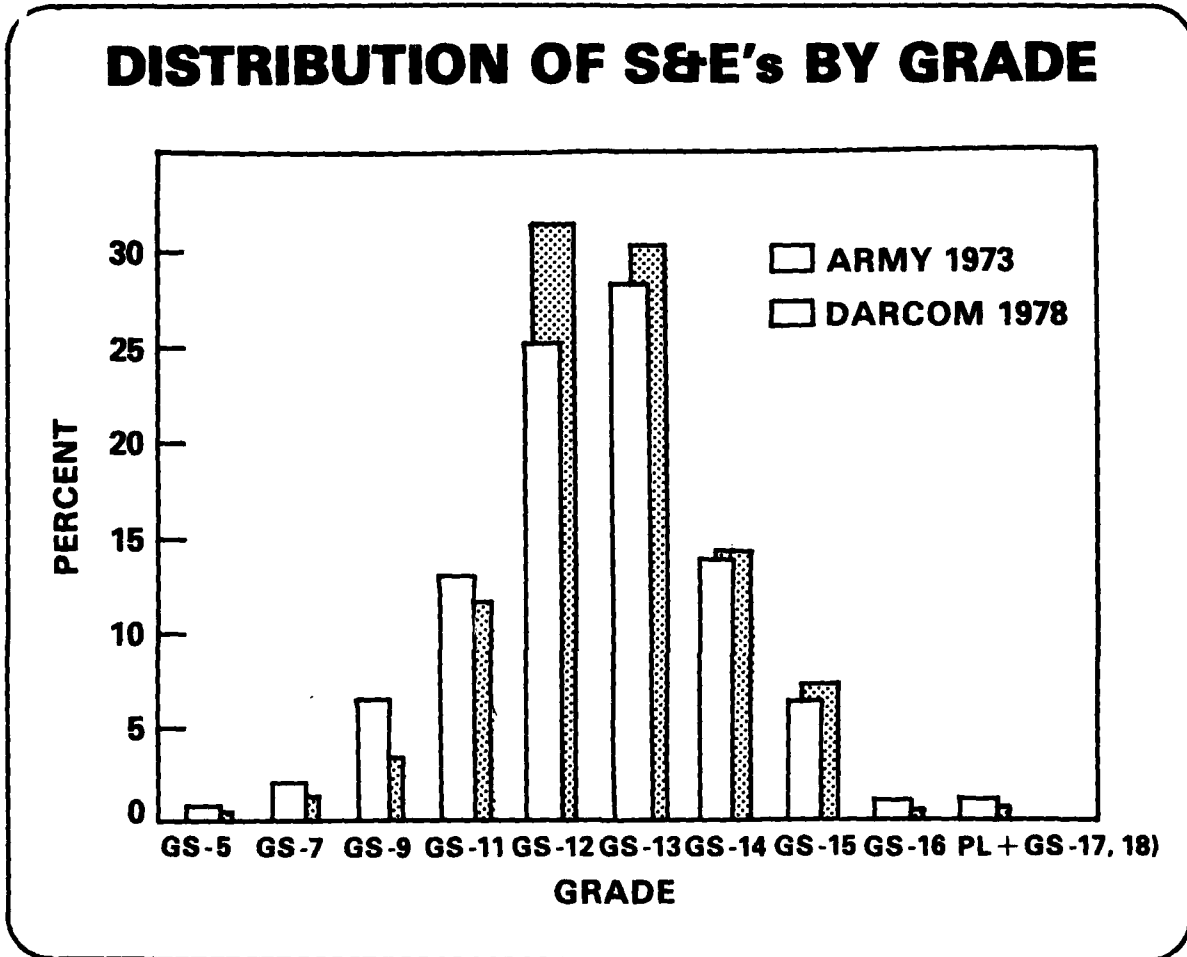

III-26

DISTRIBUTION OF S&E BY AGE

The concentration of the S&E population in the higher grades results in an aging of the S&E population. Chart III-27 compares the age distribution of the DARCOM 1977 S&E's to that regarded as an acceptable distribution—1973.

Note that more than 15% of the 1977 DARCOM S&E workforce were eligible for retirement.

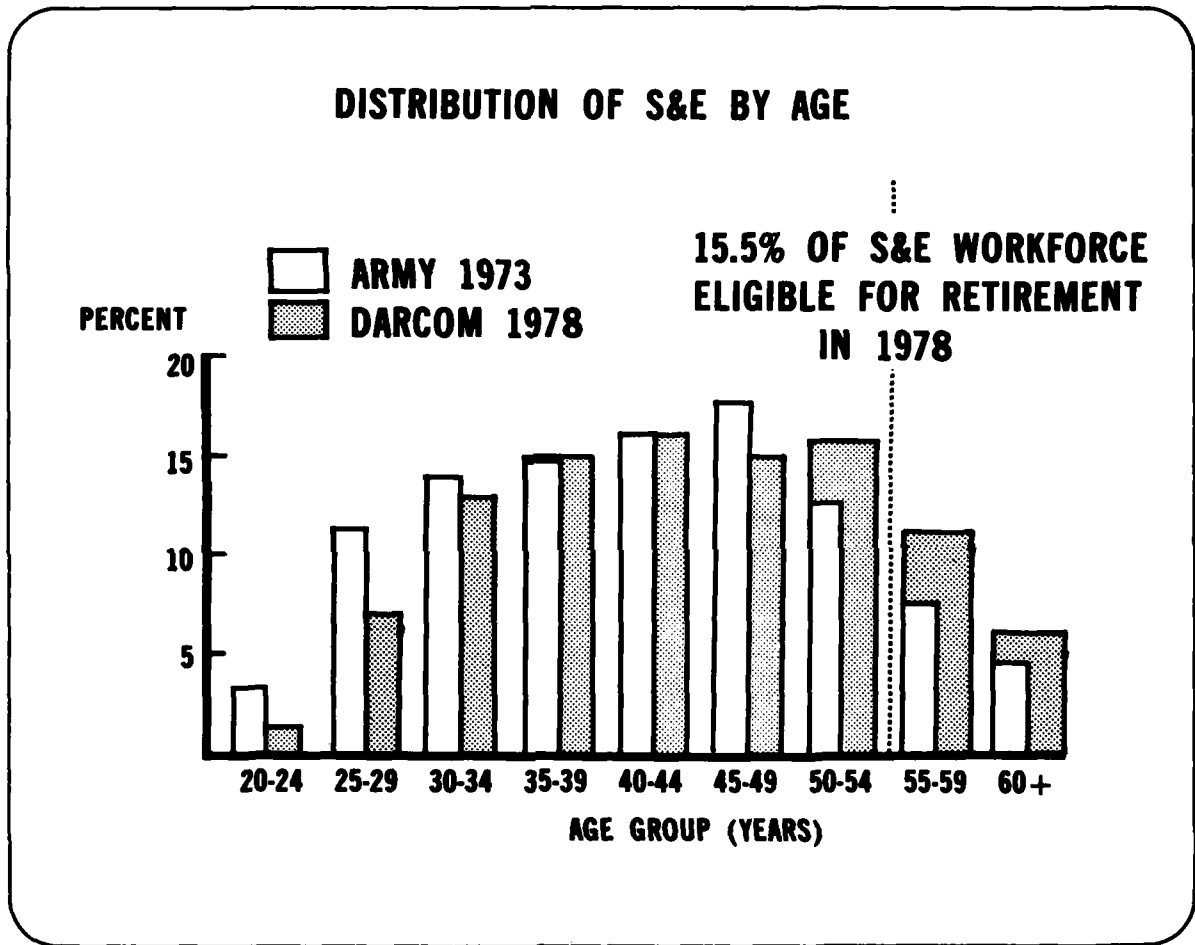

III-27

AVERAGE AGE OF DARCOM S&E PERSONNEL

Chart III-28 shows the increase in the average age of DARCOM's S&E's from 1972 to 1978.

The broken line traces the results of a Sloan School (MIT) study of the productivity and creativity of scientific and engineering populations which concluded that the optimum age of the S&E workforce (for productivity and creativity) was 36. Acceptable levels of productivity and creativity (near optimal) are still achieved if the workforce average age increases at the rate of 1 year every 2 calendar years (critical slope). In the past year, the workforce aged one year, which is twice the rate of aging on the critical slope. A drop in creativity and productivity results if the Sloan pattern is exceeded.

It is significant to note that the average age of the DARCOM S&E population (solid line) is well above the critical slope. DARCOM management is most concerned with this finding.

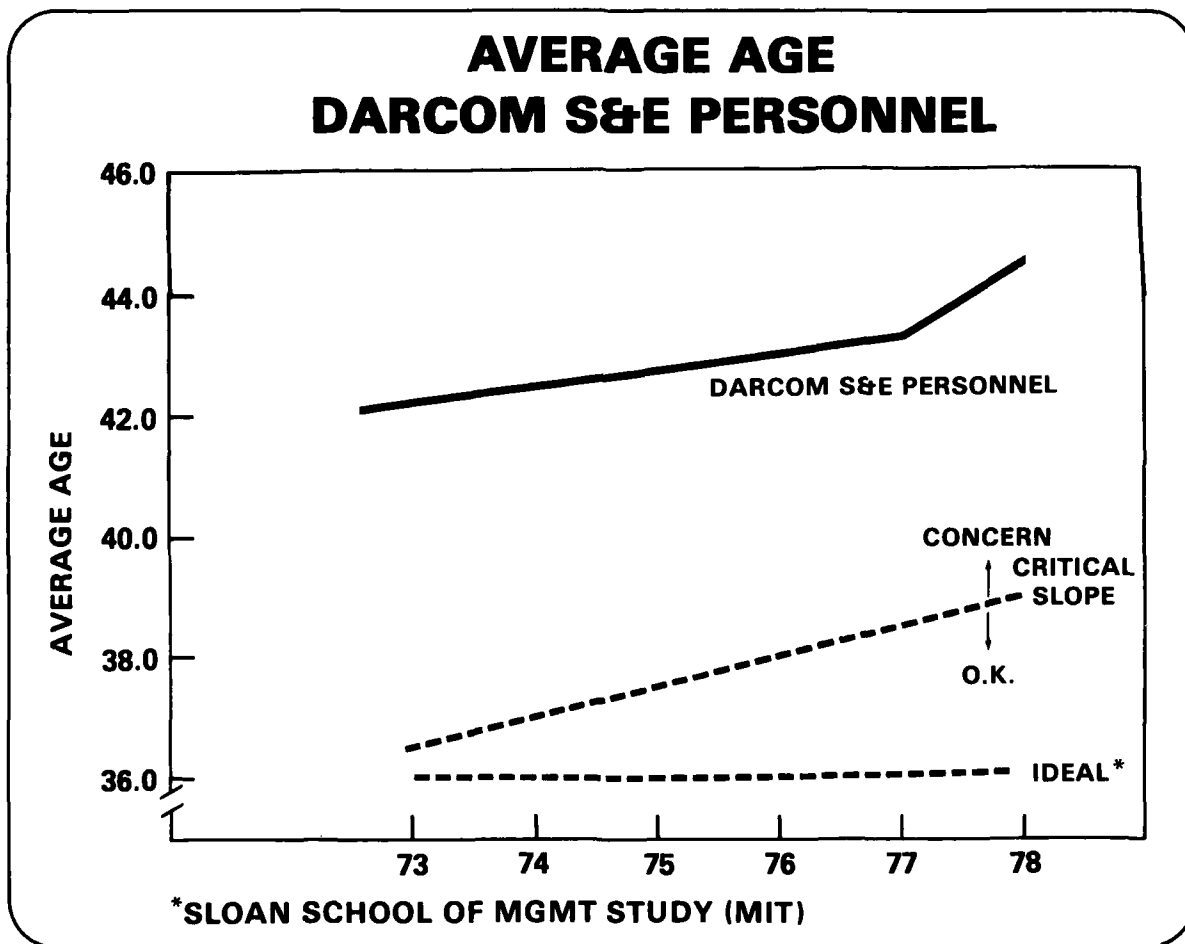

III-28

SUMMARY

Chart III-29 displays the conclusions of Section III.

SUMMARY

- **THREAT – INCREASING**
- **PIP'S – GROWING**
- **MAJOR SYSTEMS – GREATER SOPHISTICATION AND COST**
- **WORKLOAD – GROWING**
- **CAPABILITY – SHRINKING**
 - **TECH BASE**
 - **CONTRACT ADMIN**
 - **MEMORY**
 - **"SMART BUYER"**
- **SCIENTISTS AND ENGINEERS AGING**

III-29

We will close by establishing quantitatively the desirable DARCOM manpower baseline.

DARCOM RESOURCE BASELINE

The first part of this analysis covered force structure trends and other major events during the DARCOM drawdown. It was followed by a description of how manpower cuts and the upward trends in workload have impacted mission accomplishment in both logistics readiness and development.

This final portion of the briefing will describe the methodology and analysis used to arrive at the DARCOM BASELINE MANPOWER REQUIREMENT.

DARCOM RESOURCE BASELINE

IV-1

DEPOT SYSTEM MANPOWER TREND

In October 1976 the Depot Systems Command (DESCOM) faced a significant manpower cut. This proposed reduction was particularly distressing since it came after a 39% reduction in force from a level of 58,664 in FY 68 to less than 38,000 8 years later (Chart IV-2).

Because that command was already below the level of staffing required for effective mission accomplishment, DESCOM undertook a Baseline Study to determine and defend manpower levels for maximum peacetime efficiency and adequate mobilization/surge capability.

The DESCOM study was the forerunner for the total DARCOM Baseline Analysis. Because it has been accepted at all levels as a logical, defensible, persuasive approach, its methodology is once again employed.

The next 11 charts, in a shortened version, describe the DESCOM Study.

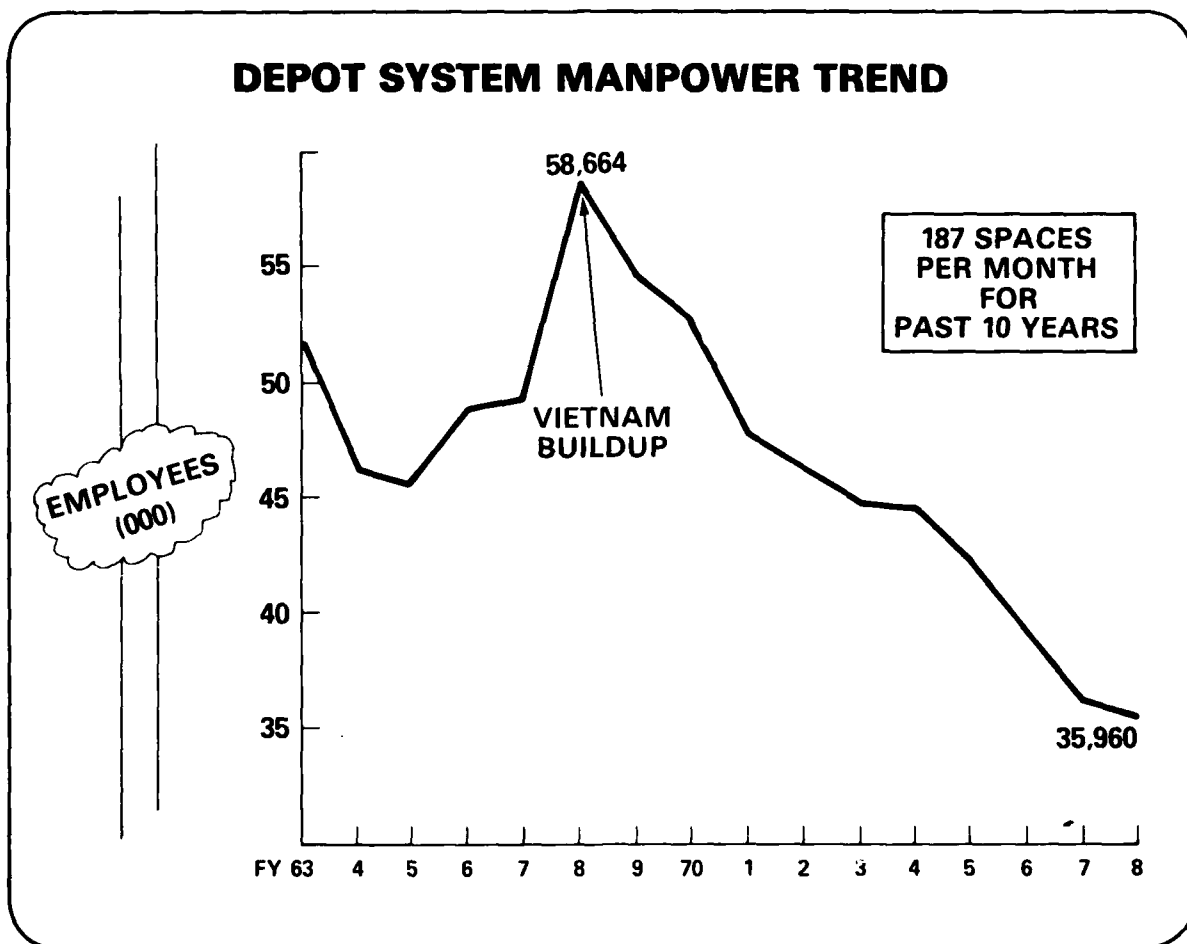

IV-2

BASELINE STUDY MILESTONES

The DESCOM Baseline Study commenced in late October 1976. By May 1977, the Anniston Pilot Study was completed. In early June the pilot study and its methodology were approved for extension to all depots. The depots conducted and completed their individual baseline studies by October. In February 1978 the validation and consolidation of the individual depot studies were completed.

BASELINE STUDY MILESTONES

ESTABLISH BASELINE
STUDY GROUP
(OCT 76)

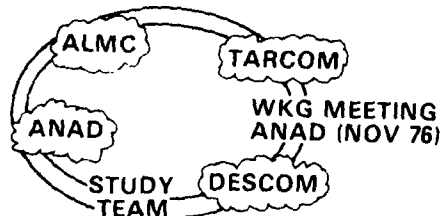

CONDUCT
PILOT STUDY
AT ANAD
(NOV 76 -
MAY 77)

DARCOM DCGMR (9 JUN 77)
APPROVED PILOT STUDY

CONDUCT STUDY
OF ALL DEPOTS
(Jun 77 - OCT 77)

COMPLETED
DESCOM BASELINE STUDY
(FEB 78)

BRIEFED
LTG D'AMBROSIO
(15 FEB 78)

BRIEFED
GEN GUTHRIE/
LTG JOHANSEN
(7 MARCH 78)

BRIEFED
LTG McGIFFER1/
MG PEIXOTTO
(11 APRIL 78)

IV-3

STRENGTH—DEPOT vs. TOTAL ARMY

Chart IV-4 shows depot strength as a function of active Army strength. The regression model was constructed using the 7 data points representing FY 68 through FY 74. Note that data points cluster closely around the regression line—indicating a strong relationship as confirmed by the .93 correlation coefficient.

However, as active Army strength stabilized at around 785,000 in 1974, depot strength continued to reduce as shown by the FY 75-78 data points.

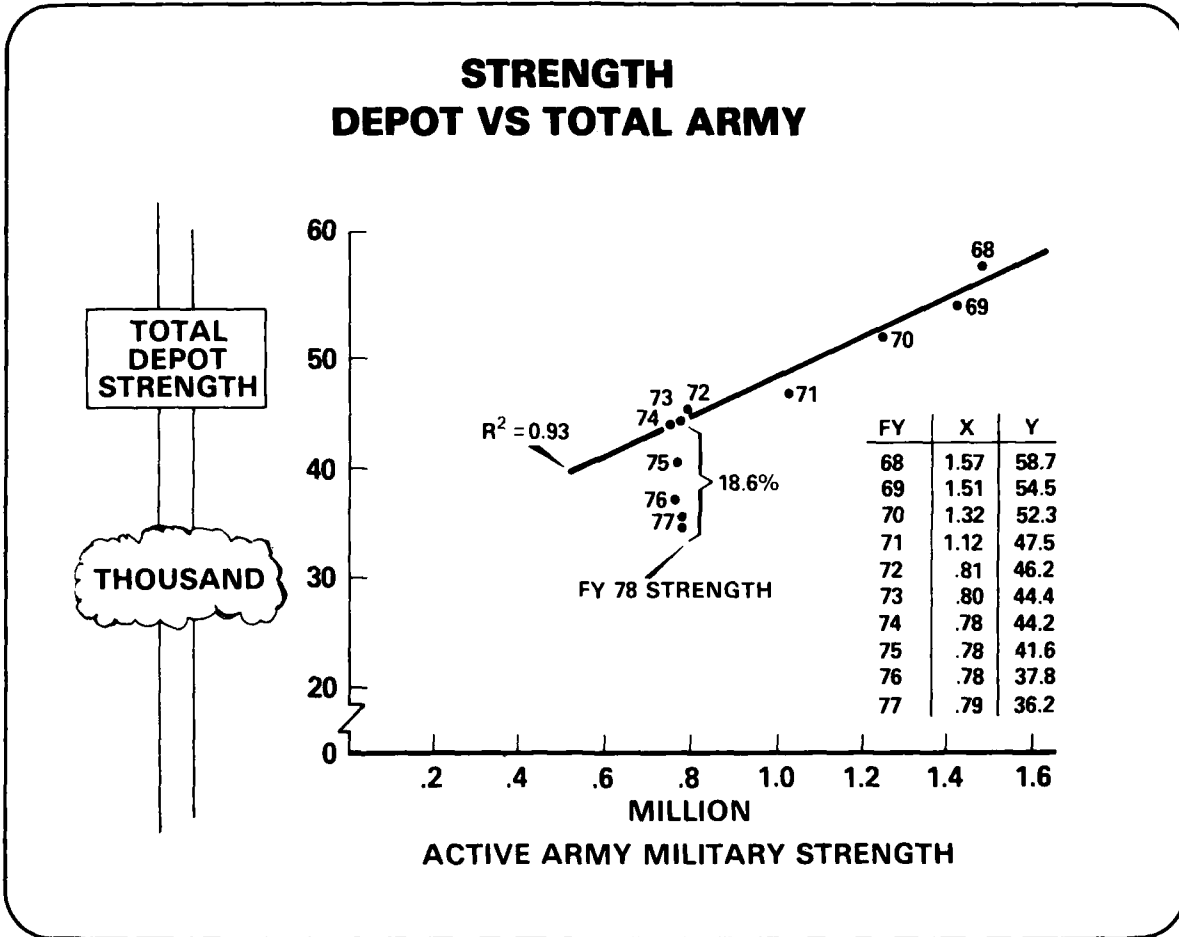

IV-4

FY 78 VALIDATED WORKLOAD

Regression models were constructed to relate manpower requirements to workload in the areas of Supply, Maintenance and Base Operations. Workload projections were developed by DARCOM's Materiel Readiness Commands. The results of these models indicated that to efficiently and economically accomplish the validated peacetime workload, 43,255 manyears of effort would be required (Chart IV-5).

FY78 VALIDATED PEACETIME WORKLOAD

<u>MISSION</u>	<u>VALIDATED MANYEARS</u>
GENERAL SUPPLIES (INCL AMMO)	11,384
MAINTENANCE	21,937
INSTALLATION SUPPORT	8,755
FIXED	(2,868)
VARIABLE	(5,887)
OTHER (MISC)	1,179
TOTAL =	<u>43,255</u>

IV-5

DESCOM SUPPLY AIF CURVE

Since the Army Industrial Fund rate is a measure of the operating efficiency of a depot, it was used to assess peacetime efficiency (Chart IV-6).

The supply AIF curve shown was constructed using historical data points for FY 74-77 and OSD planning criteria for shift efficiencies. The area of efficiency lies in the range of 80-125% utilization of one shift. DESCOM was operating at \$19.56 per DLH with 10,061 people authorized at the time of this study. This \$19.56 per hour rate includes direct material and other direct costs in addition to the basic AIF recovery rate. If the level of effort could be raised to support the validated workload—11,384 manyears—a 4.5% reduction in the rate could be achieved.

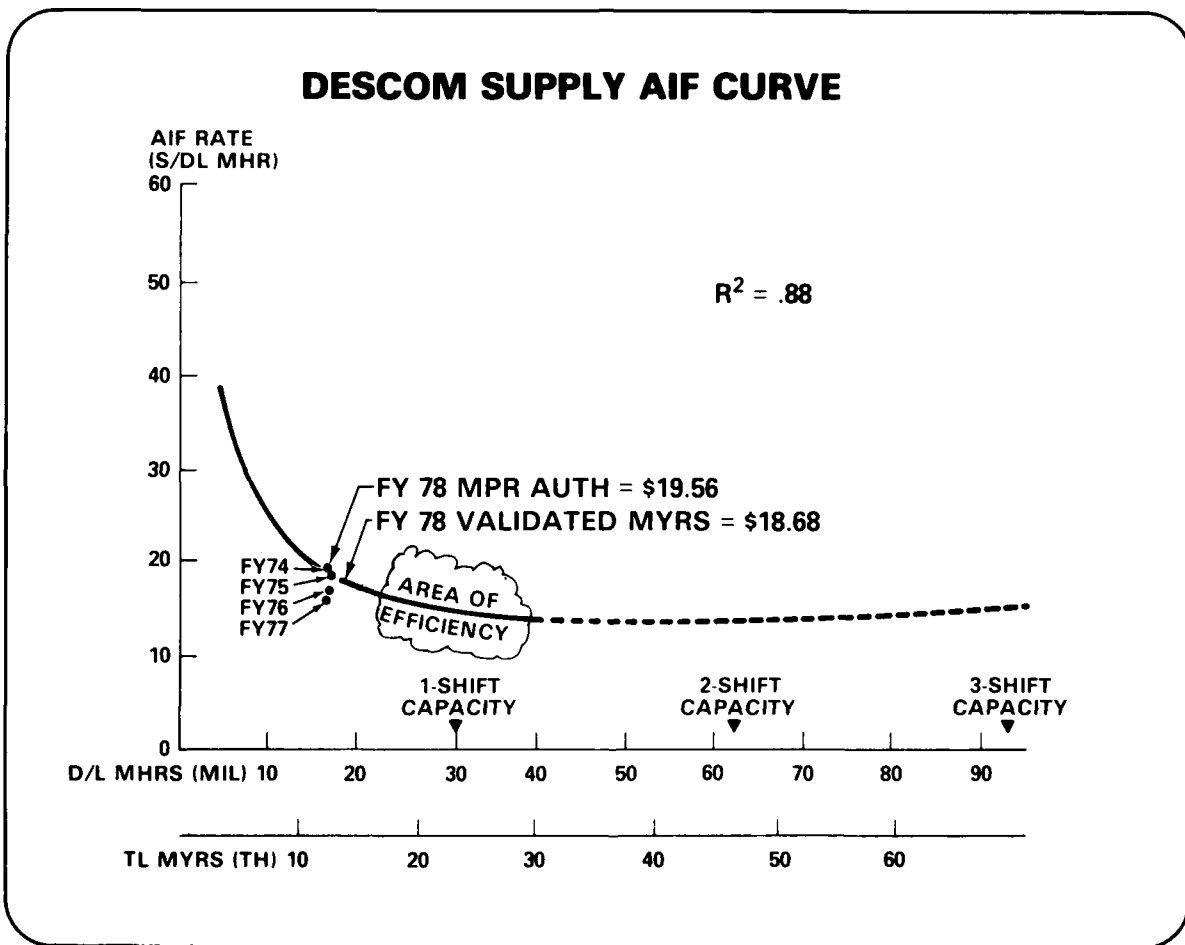

IV-6

DESCOM MAINTENANCE AIF CURVE

The AIF rate from the maintenance model is \$29.48 per DLH for the then authorized manpower level of 16,870. The area of efficient operation for maintenance is about the same as it was for supply. If adequate manpower—about 22,000—was authorized to execute the FY 78 planned direct labor program, the AIF rate would drop 9.5% to \$26.78 per direct labor hour. Note that this level of effort would place DESCOM in the designated area of efficiency. Considering the number of DL manhours to be worked, the savings are substantial.

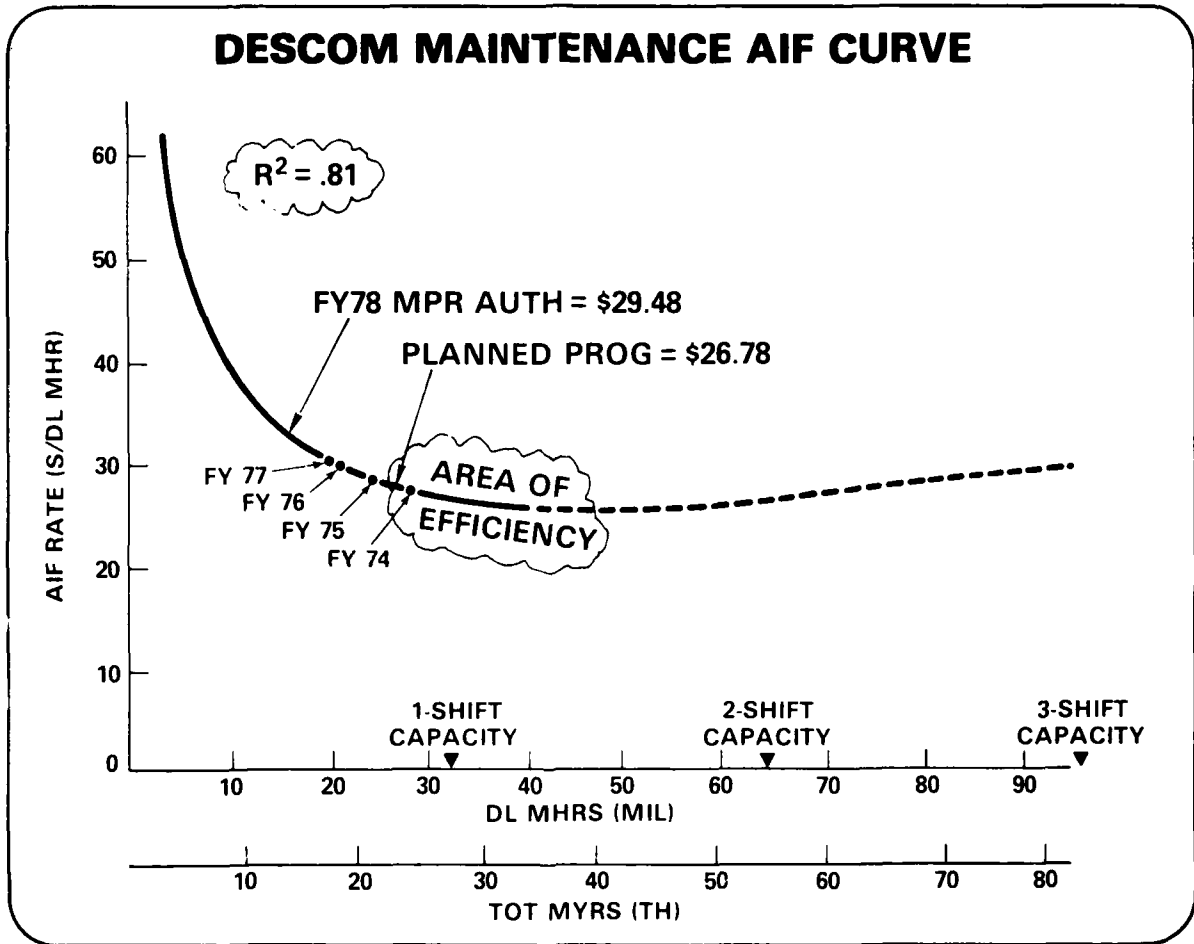

IV-7

After establishing an efficient peacetime manpower value we examined the surge/mobilization requirement.

READINESS CONDITION (REDCON) CRITERIA

In this analysis the depot readiness for mobilization was stated both in terms of REDCON levels and percentages (Chart IV-8).

The readiness percentage is computed using the equation on the chart. Then, the readiness percentage is translated to the appropriate REDCON level by using the table.

The REDCON criteria are those specified in AR 220-1.

READINESS CONDITION (REDCON) CRITERIA

<u>REDCON</u>	<u>CRITERIA</u>	<u>READINESS STATUS</u>
C-1	ABOVE 95.0%	FULLY READY
C-2	85.0% TO 94.9%	SUBSTANTIALLY READY
C-3	75.0% TO 84.9%	MARGINALLY READY
C-4	BELOW 75%	NOT READY

$$\text{READINESS} = \frac{\text{CAPABILITY}}{\text{REQUIREMENT}} \times 100\%$$

IV-8

DESCOM—COST OF READINESS (GENERAL SUPPLIES)

Mobilization work standards were developed based on mobilization planning criteria. Then total mobilization manpower requirements were developed by adding direct labor manpower, direct labor for deploying units, and indirect and industrial support manpower.

Chart IV-9 shows direct labor requirements for supply operations as a function of readiness. With the FY 78 authorized direct labor strength of 7,677, DESCOM was shown to be REDCON 3—78% ready on M-day. The numbers of additional direct labor people and costs to achieve REDCON 1 and 2 postures on M-day are shown (e.g. an additional 1,816 direct labor personnel at a cost of 61.3 million dollars would be required for REDCON 1).

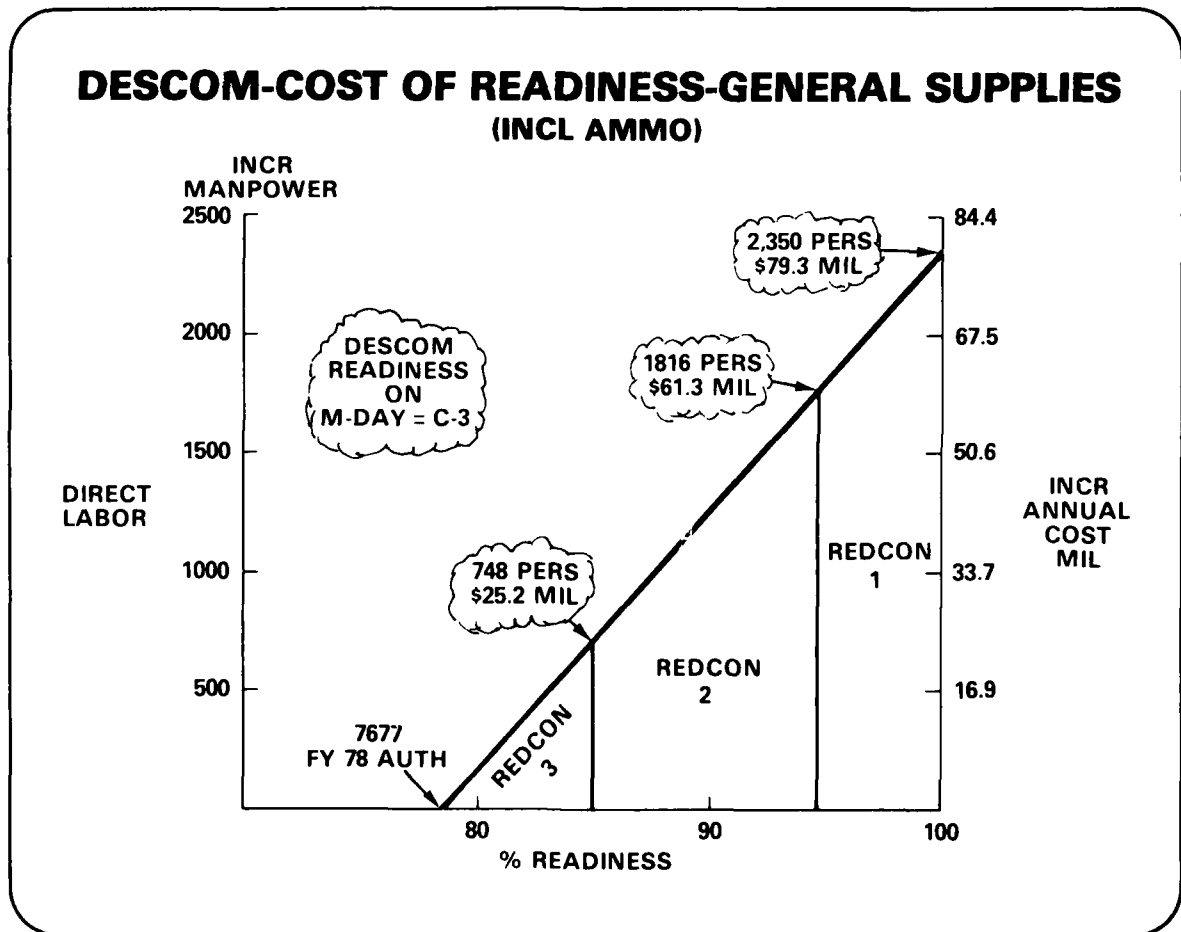

IV-9

On the following chart DESCOM's cost of readiness for maintenance operations is determined.

DESCOM COST OF READINESS (MAINTENANCE)

DESCOM's readiness condition in maintenance is shown as REDCON 4—53 percent ready—with the authorized baseline strength of 11,800 direct labor people (Chart IV-10).

Almost 8,000 direct labor personnel would be needed to achieve a REDCON 2. Over 3,500 of these direct labor personnel could be used now to execute the FY 78 program.

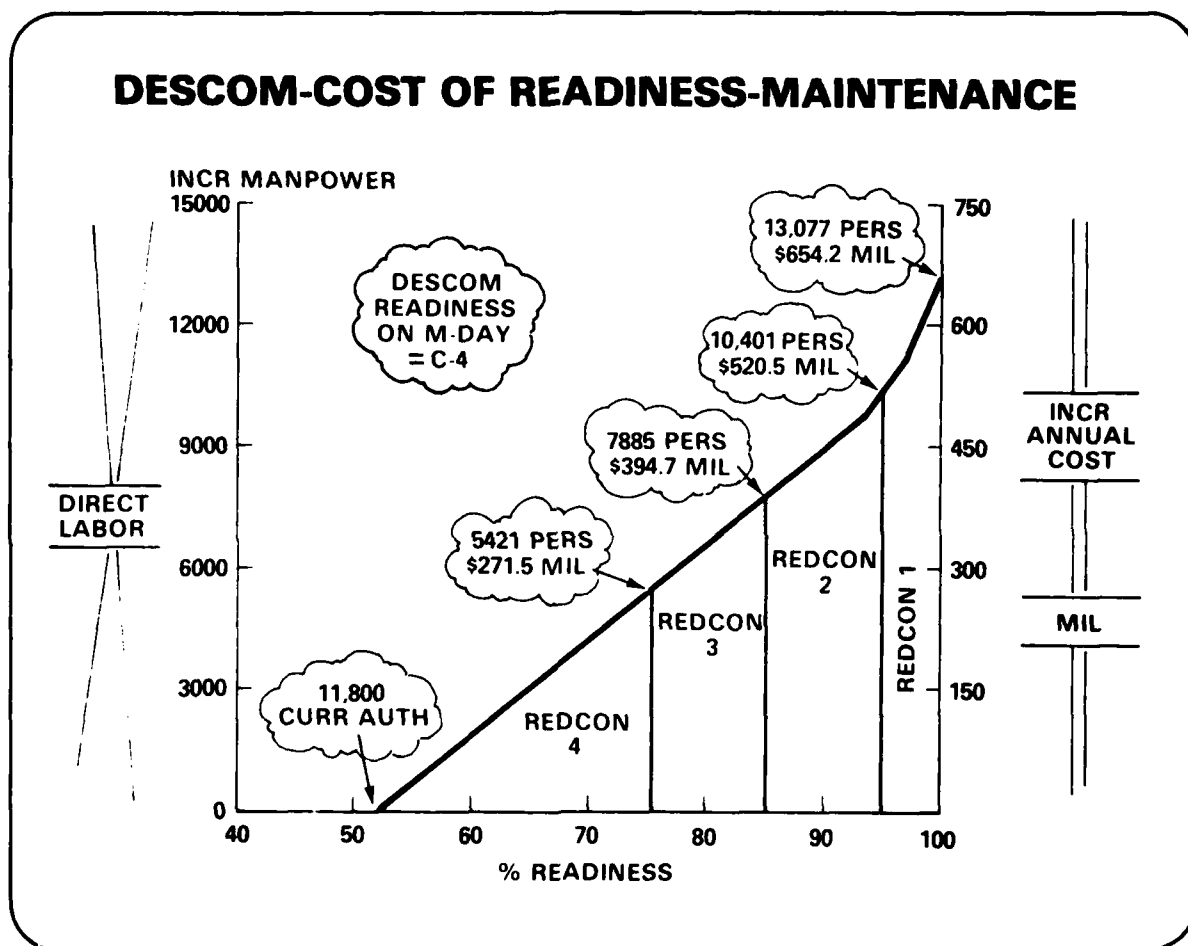

IV-10

The results of this phase of the analysis are summarized on the next chart.

TOTAL DESCOM BASELINE STRENGTH vs. FY 78 AUTH

Chart IV-11 compares the total authorized DESCOM strength to that strength required to achieve REDCON 1 and 2 postures. At the left, the FY 78 authorization includes direct, indirect and installation support personnel. The REDCON for the current strength is also shown. Under REDCON 2, the baseline strength required to meet the initial surge requirements—7 days a week, 12 hrs a day—is 49,697. The shortfall is the difference between the baseline strength and the FY 78 authorized CEP (civilian end strength projection). Similar figures are shown for REDCON 1. It is interesting to note that the REDCON 1 baseline strength is only slightly larger than the strength of the depot system at the peak of the Vietnam war.

This relationship is important in the analysis of the total DARCOM strength required to support mobilization which will be described later.

TOTAL DESCOM

BASELINE STRENGTH VS FY 78 AUTH

	FY 78 AUTH	CURRENT REDCON	REDCON 2 (85%)		REDCON 1 (100%)	
			BASELINE	SHORTFALL	BASELINE	SHORTFALL
SUPPLY	10,061	3	11,021	960	13,078	3,017
MAINT	16,870	4	27,901	11,031	35,154	18,284
INST SPT	7,754		9,633	1,879	11,092	3,338
OTHER	1,142		1,142	0	1,310	168
TOTAL	35,827		49,697	13,870	60,634	24,807

IV-11

STRENGTH—DEPOT vs. TOTAL ARMY

Earlier in this briefing we cited the fact that the depot system's work force had continued to decline, while that of the green suit army had stabilized at around 785,000 (Chart IV-12). Also, note that a total depot strength of 43,255 was required to accomplish the FY 78 validated peacetime workload.

Now, let's examine the same regression relationship of depot strength to total Army to show the relative position of depot strength required to accomplish the validated peacetime workload and the strength needed to achieve REDCON 1.

First, using the historical experience and the active army strength for FY 78 (contained in the President's budget) of 774,200, the depot strength should be 44,111. A DESCOM peacetime validated workload strength of 43,255 falls slightly below this level. Since the 43,255 can be efficiently and economically employed, and since it provides a major improvement in our mobilization readiness posture, it was recommended that the depot baseline strength be established at 43,255.

Notice that although the baseline strength required to support a mobilization REDCON 1 status would be consistent with an active Army force of 1.6 million (that at the height of Vietnam), it is inconsistent with the FY 78 active Army force of 774,200. Moreover, this mobilization baseline strength could not be efficiently and economically utilized in peacetime.

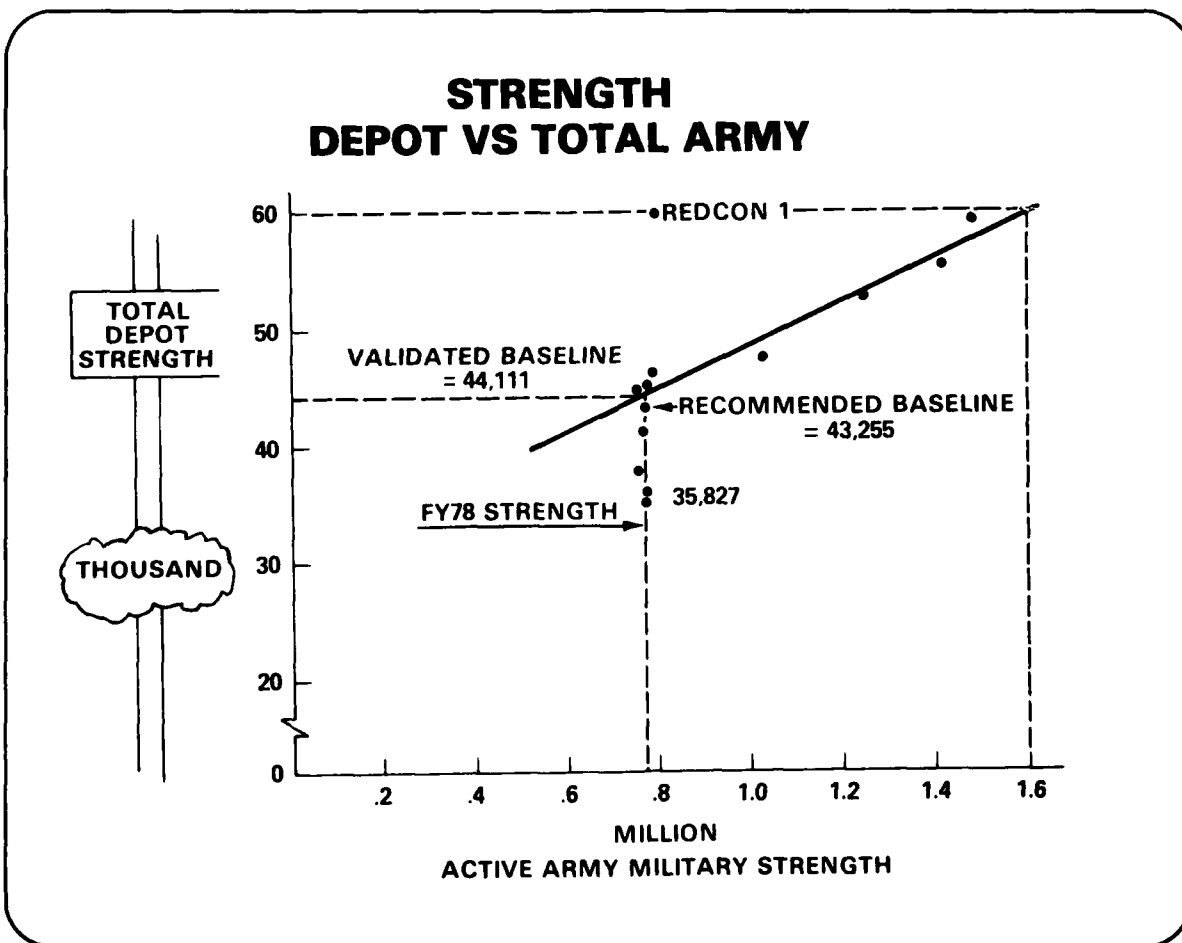

IV-12

STRENGTH—DEPOTS vs. TOTAL ARMY—DEPOTS vs. IOE

In section two of this analysis the concept of intensity of operational employment was described. Chart IV-13 compares the baseline for DESCOM determined by two alternative approaches, that of the DESCOM study and that based on a regression model employing the IOE concept. The DESCOM study results are shown by the inner dashed lines; the results of the regression model utilizing the IOE concept are shown by the outer dashed lines. The difference in the two validated baselines is less than 1% with the correlation coefficient used in the IOE concept being slightly higher—.95.

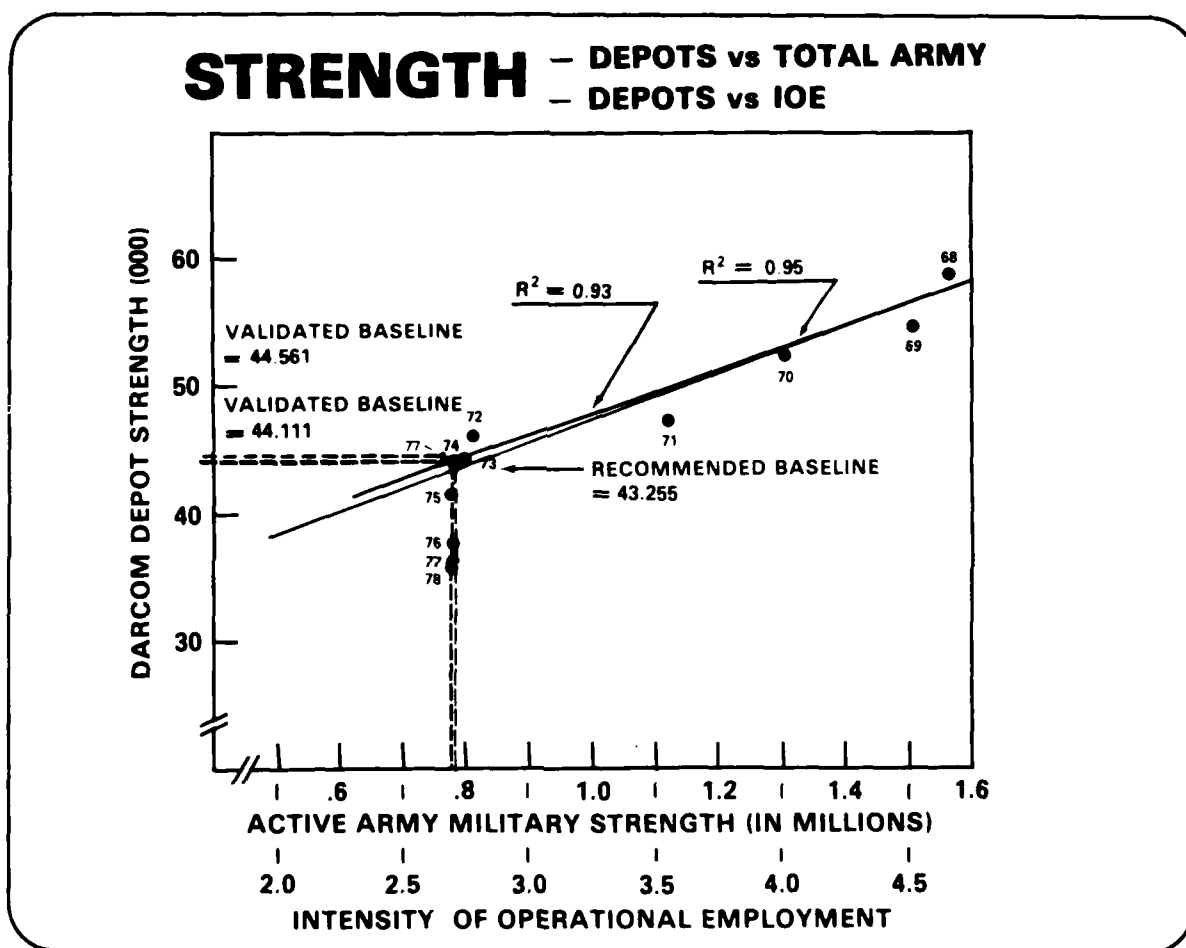

IV-13

Both methodologies were used to determine the overall DARCOM materiel readiness baseline. Specifically, regression models employing the IOE concept were used while following the basic approach developed in the DESCOM Baseline Study. The results of this analysis follow.

MATERIEL READINESS STRENGTH AUTHORIZED

Chart IV-14 reflects the trend of DARCOM materiel readiness end strength authorized over the past 16 years. Note that authorized levels have reduced by nearly 63,000—nearly a 41% decrease.

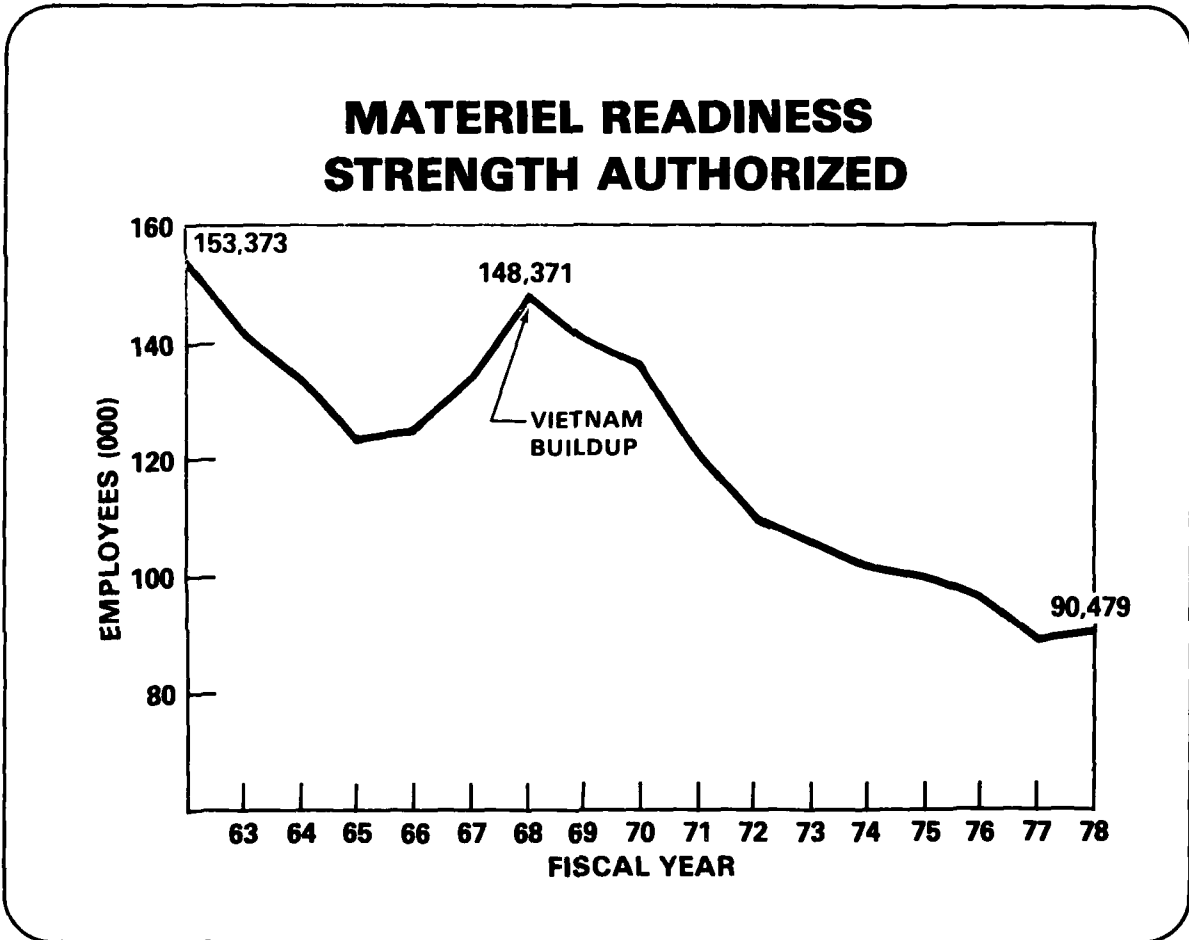

IV-14

MR PERSONNEL vs. TOTAL ARMY

Chart IV-15 portrays the relationship of materiel readiness personnel levels to those of the total Army. The regression line shown was based on the data from FY 68 through FY 74. Note the strong relationship during these years as evidenced by the .94 correlation coefficient.

However, as the active Army stabilized at around 785,000 in 1974, DARCOM MR strength continued to drop. In fact, an 11.3% decrease resulted during the years FY 75-FY 78.

MR PERSONNEL vs TOTAL ARMY

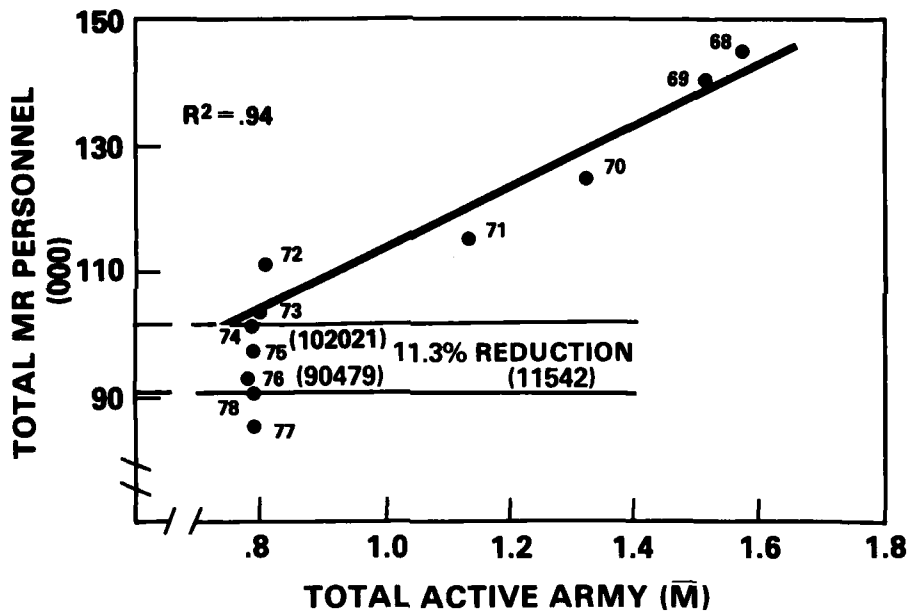

IV-15

MR PERSONNEL vs. IOE

Chart IV-16 displays the relationship of total materiel readiness to IOE. The strong relationship obtained through FY 74 ($R^2=.94$) establishes a firm foundation for deriving the DARCOM materiel readiness baseline.

While an FY 78 IOE level of 26.1 indicates a requirement for 110,173 MR personnel, an adjustment factor was introduced which considered productivity, contracting out, mandated programs and other influences, resulting in a recommended baseline requirement of 106,214.

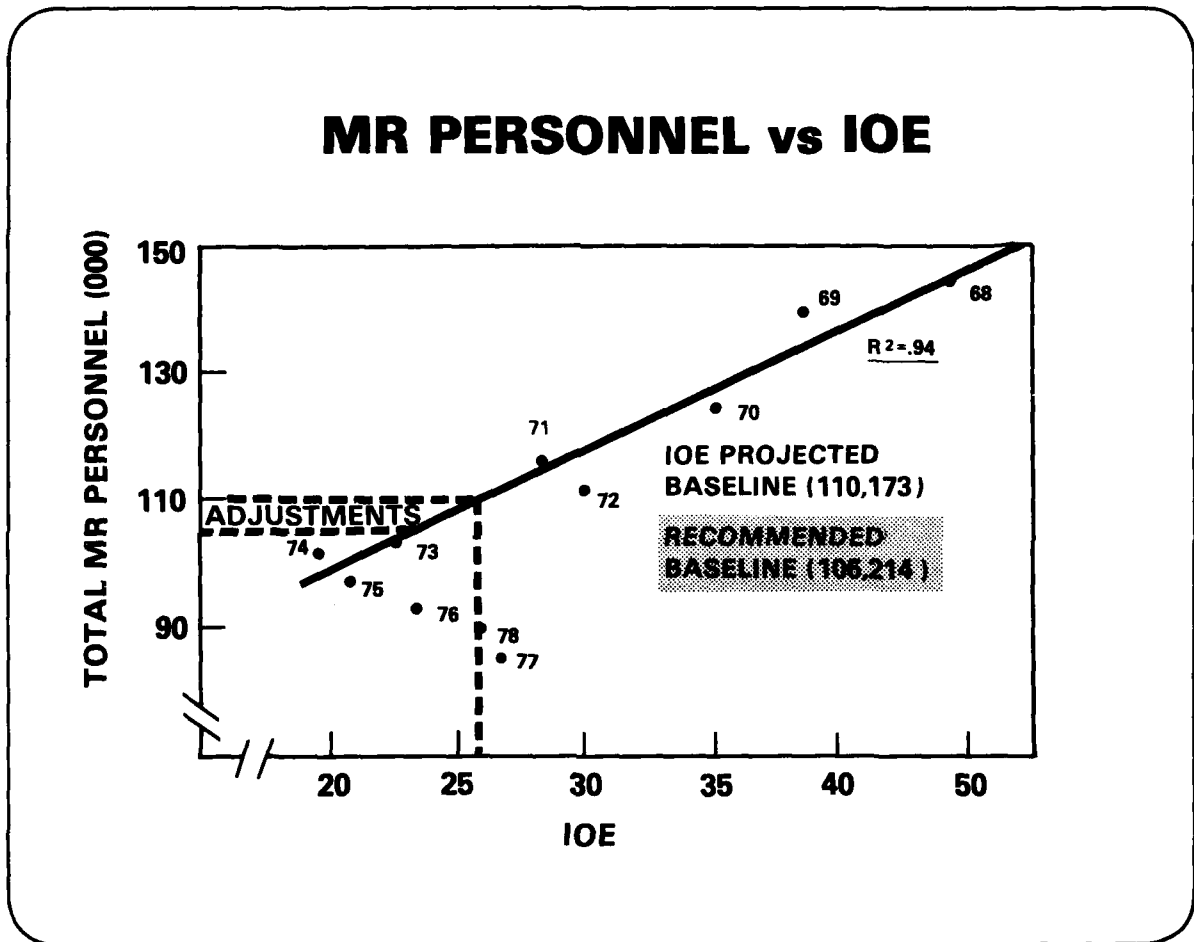

IV-16

SYSTEMS—NEXT 5 YEARS

Chart IV-17 recalls to the reader's attention the systems scheduled for fielding during the next 5 years. The RDTE effort associated with these systems spans a considerable period of time. This lag effect is reflected on Chart IV-18.

NEW SYSTEMS

AIR DEFENSE

- * STINGER
- * ROLAND
- * PATRIOT
- * DIVAD GUN

ARMOR

- M60A3
- * XM-1
120MM GUN
- * FVS
- CVS
- IFV
- IFV FPW
- VERFWS-S
- * ITV

AVIATION

- * UH-60
- * CH-47D
- * ASH
- * RPV
- * HELLFIRE
- * AAH-64
XM 788/789
TADS/PNVS

COMMUNICATIONS, COMMAND & CONTROL

- * SOTAS
- * TOS
- TACSATCOM
- * MOBILE SUBS EQUIP
- * AUTO COMM CENT
- * AN/TTC-39
- AN/TYC-39
- * NAVSTAR-GPS
- * SINGARS V
- AUTOSEVOCOM II
- PLRS
- REMBASS
- JTIDS

ENGINEER

- SLUFAE
- FAMECE/UET
- GEMSS

INTELLIGENCE

- TRAILBLAZER
- QUICKLOOK
- TACELIS
- QUICK FIX
- TACJAM
- TECHNICAL ESM

FIELD ARTILLERY

- * COPPERHEAD
- BCS
- * GSRS
- FAMAS
- * PERSHING II
- XM736
- * AN/TPQ-37
- * LTD/GLLD
- * TACFIRE

INFANTRY

- FASCAM
- SAW
- VIPER
- LWCMS
- DNT

*MAJOR SYSTEMS

IV-17

AGE OF NEW TECHNOLOGY

The distribution of the age of the technology built into the soon-to-be fielded systems is displayed on Chart IV-18. The average and median ages of the representative technology fall in the shaded region or, said another way, the technology of 1970-72 drove the systems to be fielded in 1978-83.

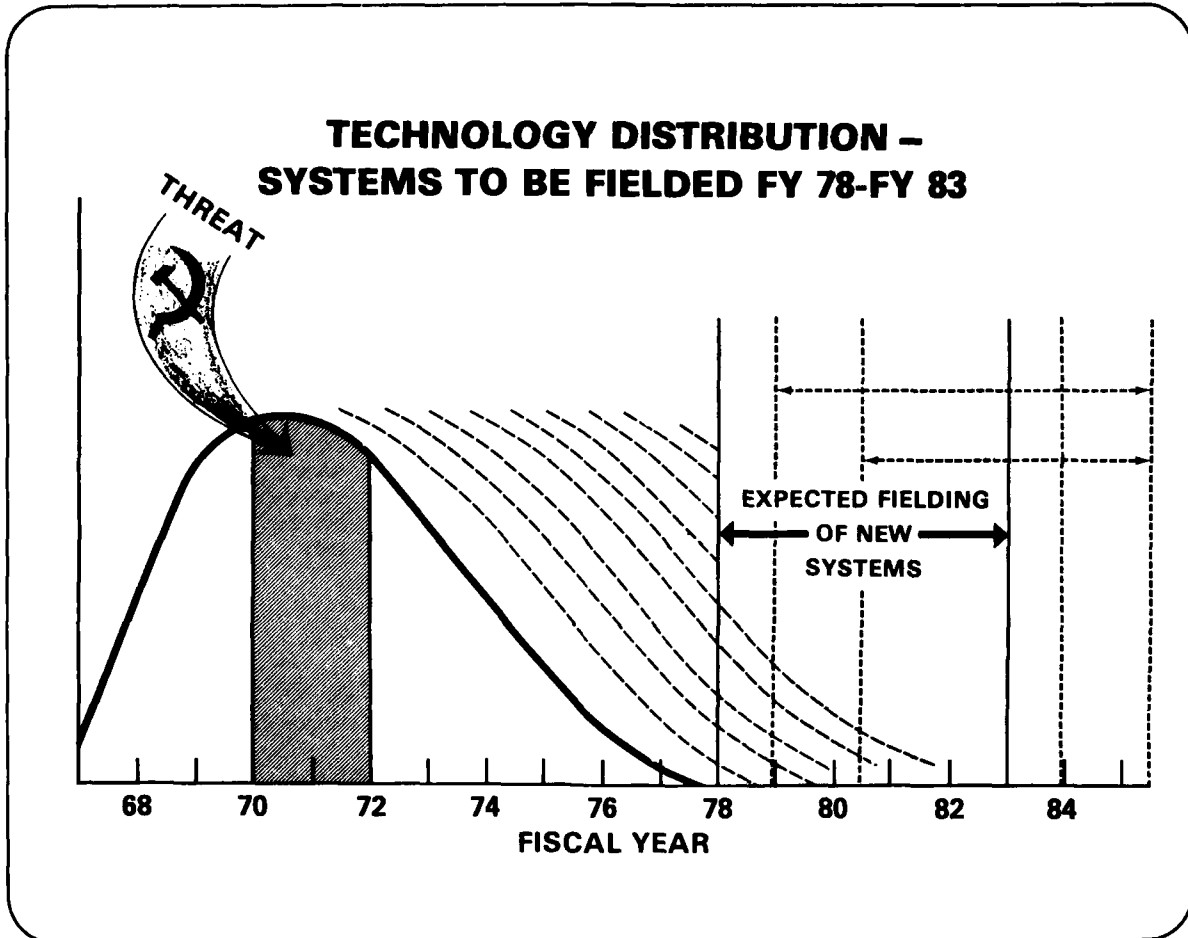

IV-18

As technology advances and systems become more sophisticated to meet or exceed the Threat, the duration and difficulty of the RDTE effort are extended at a time when in-house capability is reducing. Therefore, even if the RDTE in-house force were sustained at the 1970-72 level, it is unlikely that reduction to the development cycle of new systems in the post FY 82 period could be achieved.

Thus, we believe that the strength during that period represents the **minimum** staffing required to maintain a credible RDTE effort.

RDTE BASELINE

Chart IV-19 describes the RDTE strength during the 1970-72 time-frame. The average strength during this period is 28,840 and forms the basis for the recommended RDTE baseline strength displayed on Chart IV-20.

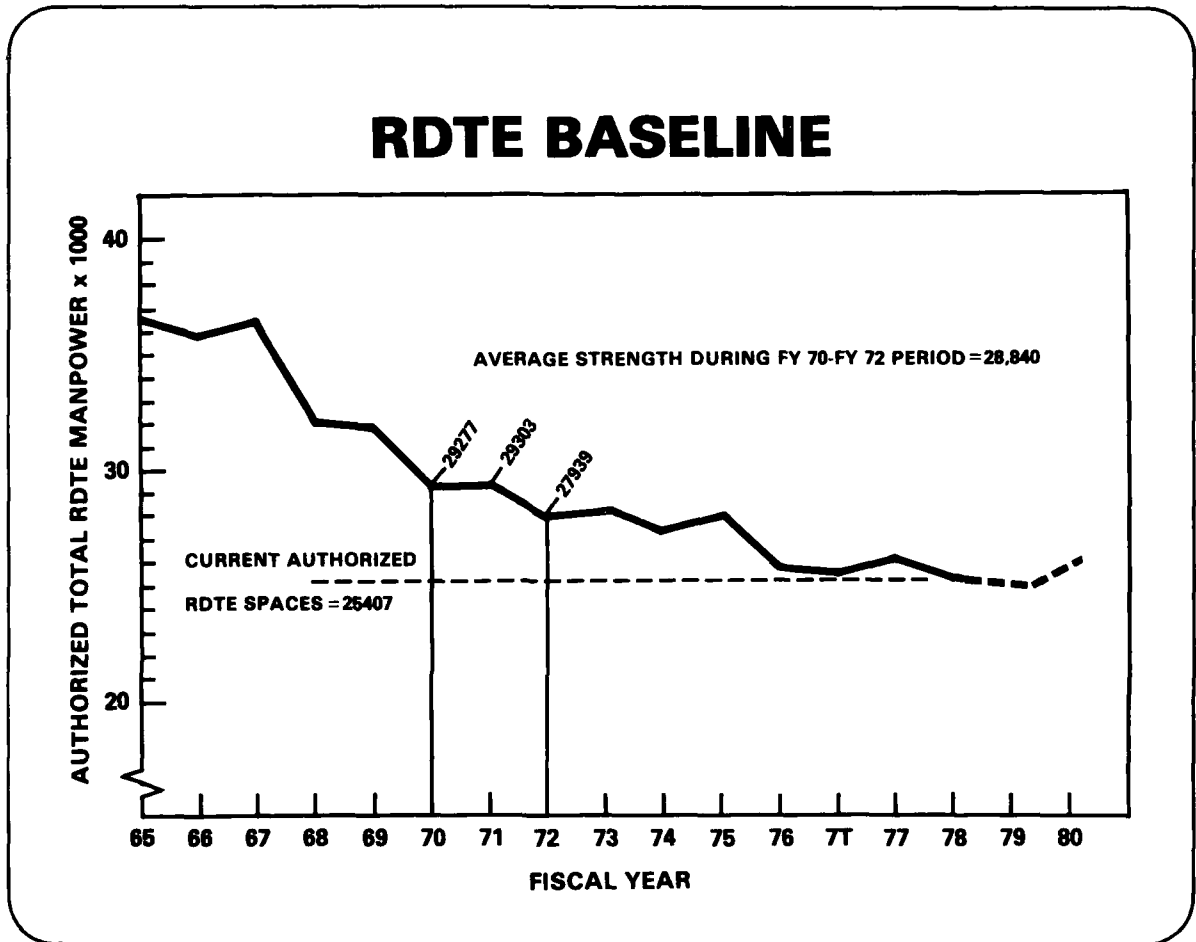

IV-19

DARCOM RDTE RECOMMENDED BASELINE

The RDTE baseline is the sum of the average authorized strength during 1970-72 and the additional RDTE unique spaces required by mandated programs.

We contend that it would not be appropriate to reduce the estimated RDTE baseline for productivity since other factors (e.g. complexity, sophistication, test time, etc.) have more than a compensating effect.

DARCOM RDTE RECOMMENDED BASELINE

**FY 70 TO FY 72: PERIOD OF RDTE EFFORT
YIELDING TECHNOLOGY
INCLUDED IN SYSTEMS TO BE
FIELDDED FY 78-83**

**AVERAGE RDTE AUTHORIZED SPACES DURING
THIS PERIOD:**

TOTAL MILITARY AND CIVILIAN:	28840
+ Δ MANDATED PROGRAMS:	<u>268</u>
TOTAL RDTE RECOMMENDED BASELINE:	29108

AD-A084 140

TITANIUM INST AND TITANIUM AND MAGNESIUM WORKS ZAPOR--ETC F/G 15/5
THE DARCOM MANPOWER BASELINE REQUIREMENT AS OF END, FISCAL YEAR--ETC(U)
1978

UNCLASSIFIED

NL

2 of 2
AD
PAGE 1 OF 2

END
DATE
FILMED
6-80
DTIC

STAFFING REQUIREMENTS—DARCOM HEADQUARTERS

Chart IV-21 displays recommended DARCOM headquarters staffing requirements which resulted from two recent independent studies. The DARCOM HQ staff established a requirement for 1844 spaces (as displayed in the third column of the chart) against a TDA authorization of 1505. The Army Management Engineering Training Activity (AMETA) conducted an independent manpower analysis and recommended 1746 spaces.

STAFFING REQUIREMENTS FOR DARCOM HEADQUARTERS

ORGANIZATION	AMC TDA END FY 75	CURRENT TDA	STAFF PROPOSAL		STUDY RECOMMEND*	
			CURRENT FUNCT.	VAR W/ TDA	CURRENT FUNCT.	VAR W/ TDA
CG/CHIEF OF STAFF AREA	357	265	334	69	311	46
DCGMD AREA	356	244	307	63	294	50
DCGMR AREA	783	445	569	124	508	63
DCGRM AREA	565	530	634	104	633	103
CG's RESERVE		21	0	-21	0	-21
TOTAL DARCOM HQ	2122	1505	1844	339	1746	241

* SOURCE: US ARMY MANAGEMENT ENGINEERING TRAINING ACTIVITY (AMETA)
HEADQUARTERS DARCOM STAFF REQUIREMENT STUDY - JUNE 1978

IV-21

The baseline manpower analysis employed a regression technique to validate the AMETA findings.

DARCOM HQ vs. TOTAL DARCOM

Chart IV-22 displays a very strong relationship over time until 1975 between DARCOM HQ personnel strength versus that of total DARCOM ($R^2=.958$).

The historical projection (1835), established through the regression technique, falls between the levels recommended by the DARCOM HQ staff and AMETA.

Because of the close fit between the studies and the regression analysis value we have selected 1835 as our baseline recommendation for DARCOM headquarters.

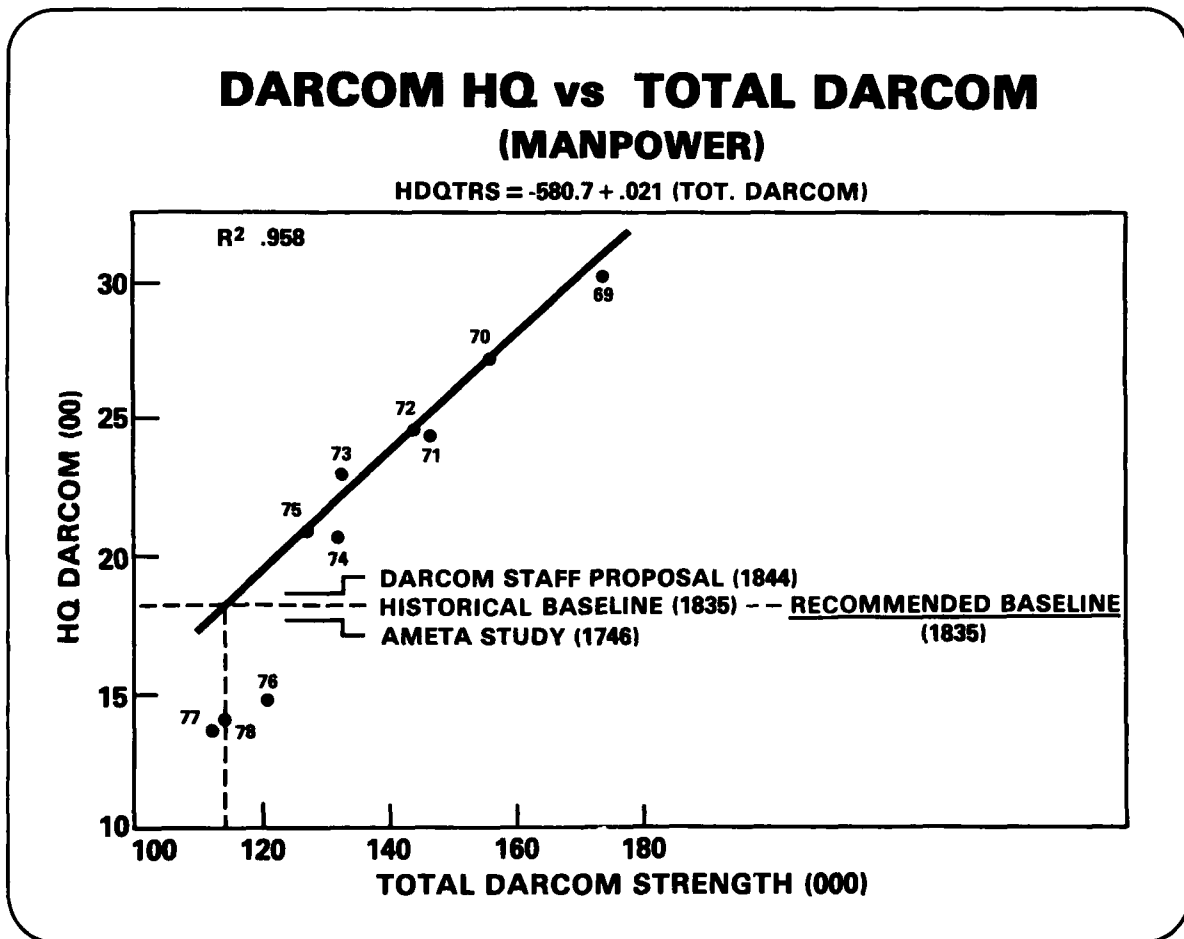

IV-22

FY 78 VALIDATED PEACETIME REQUIREMENT

In summary, to accomplish the FY 78 validated peacetime workload, an end strength of 137,157 is required. Values are provided on Chart IV-23 for each of the DARCOM components considered in this study; materiel readiness, RDTE, and HQ.

FY 78 VALIDATED PEACETIME REQUIREMENT

<u>MISSION</u>	<u>VALIDATED MANPOWER SPACES</u>
MATERIEL READINESS	106214
RESEARCH DEVELOPMENT TEST AND EVALUATION	29108
<u>DARCOM HQ</u>	<u>1835</u>
TOTAL	137157

IV-23

Having established the peacetime baseline strength required to accomplish the FY 78 workload, we will now concentrate on a determination of the baseline strength required to support surge/mobilization.

READINESS CONDITION—(REDCON CRITERIA)

As in the DESCOM portion of the briefing, DARCOM readiness for mobilization is stated in terms of REDCON levels.

READINESS CONDITION (REDCON) CRITERIA

<u>REDCON</u>	<u>CRITERIA</u>	<u>READINESS STATUS</u>
C-1	ABOVE 95.0%	FULLY READY
C-2	85.0% TO 94.9%	SUBSTANTIALLY READY
C-3	75.0% TO 84.9%	MARGINALLY READY
C-4	BELOW 75%	NOT READY

$$\text{READINESS} = \frac{\text{CAPABILITY}}{\text{REQUIREMENT}} \times 100\%$$

IV-24

MATERIEL READINESS—COST OF READINESS

Chart IV-25 reflects the materiel readiness personnel requirements as a function of REDCON level.

Note that the strength required to achieve 100% readiness (148,371) is based on the personnel authorized during the peak of the Vietnam era. The careful reader will remember that this notion was validated in the DESCOM study.

The FY 78 authorized level (90,479) places DARCOM materiel readiness in a REDCON 4 condition on M-day. The numbers of additional materiel readiness personnel and associated costs to achieve improved readiness conditions are shown. For example, 50,482 additional personnel and 1074.8 million dollars are required to achieve a REDCON 1 status.

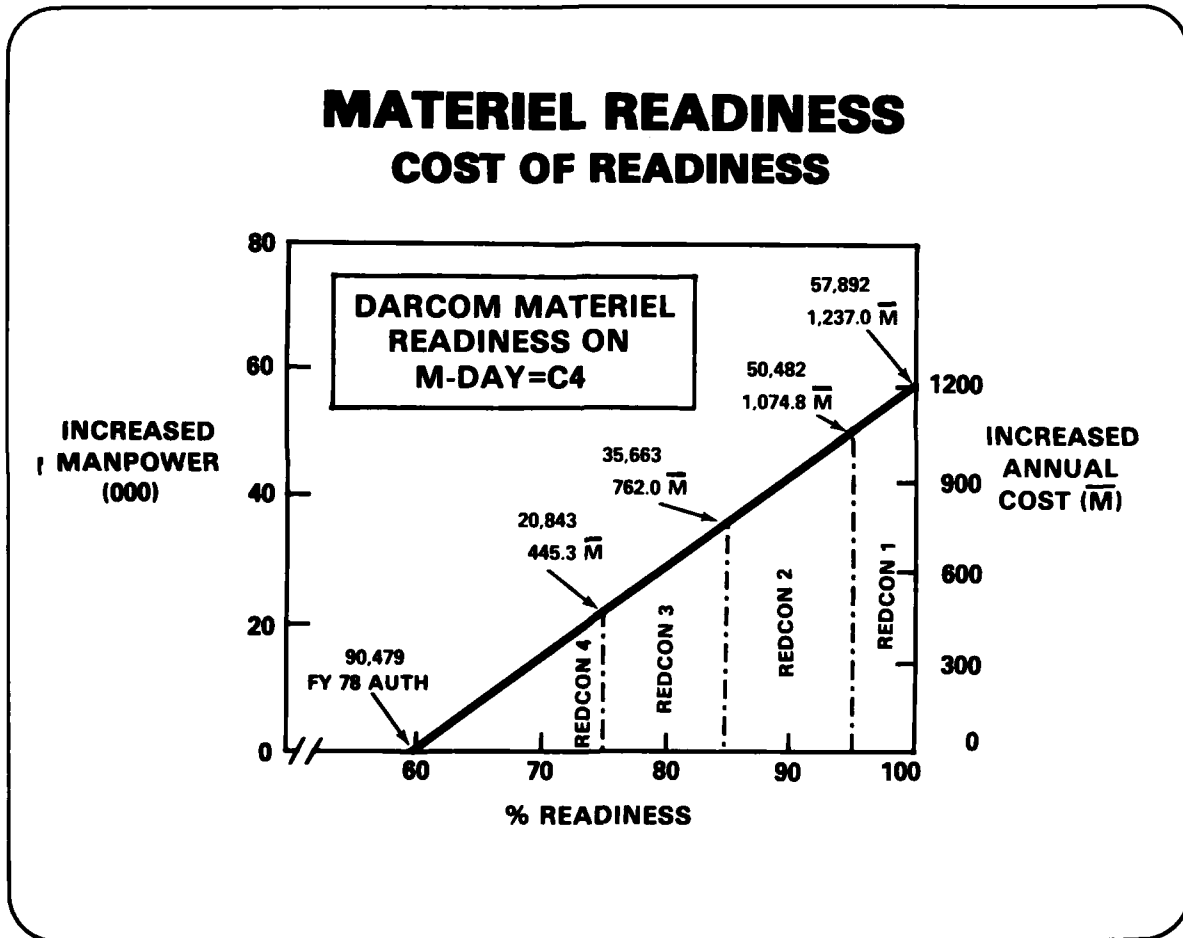

IV-25

RDTE—COST OF READINESS

Similarly, Chart IV-26 reflects research, development, test and evaluation requirements as a function of REDCON level.

The FY 78 authorized level (25,407) places DARCOM RDTE in a REDCON 4 condition on M-day.

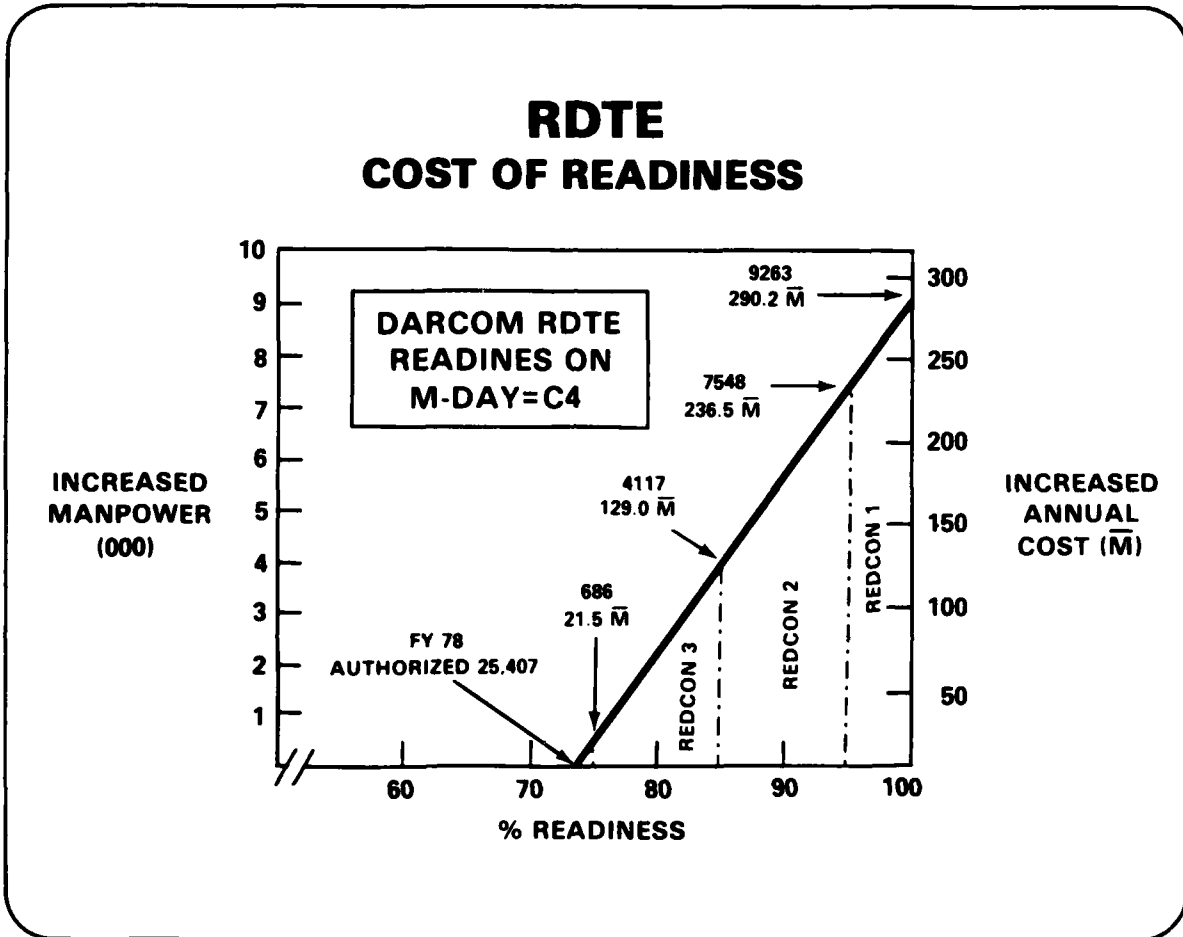

IV-26

DARCOM HQ—COST OF READINESS

Chart IV-27 displays DARCOM headquarters requirements as a function of REDCON level.

The FY 78 authorized level (1505) places DARCOM HQ in a REDCON 4 status on M-day.

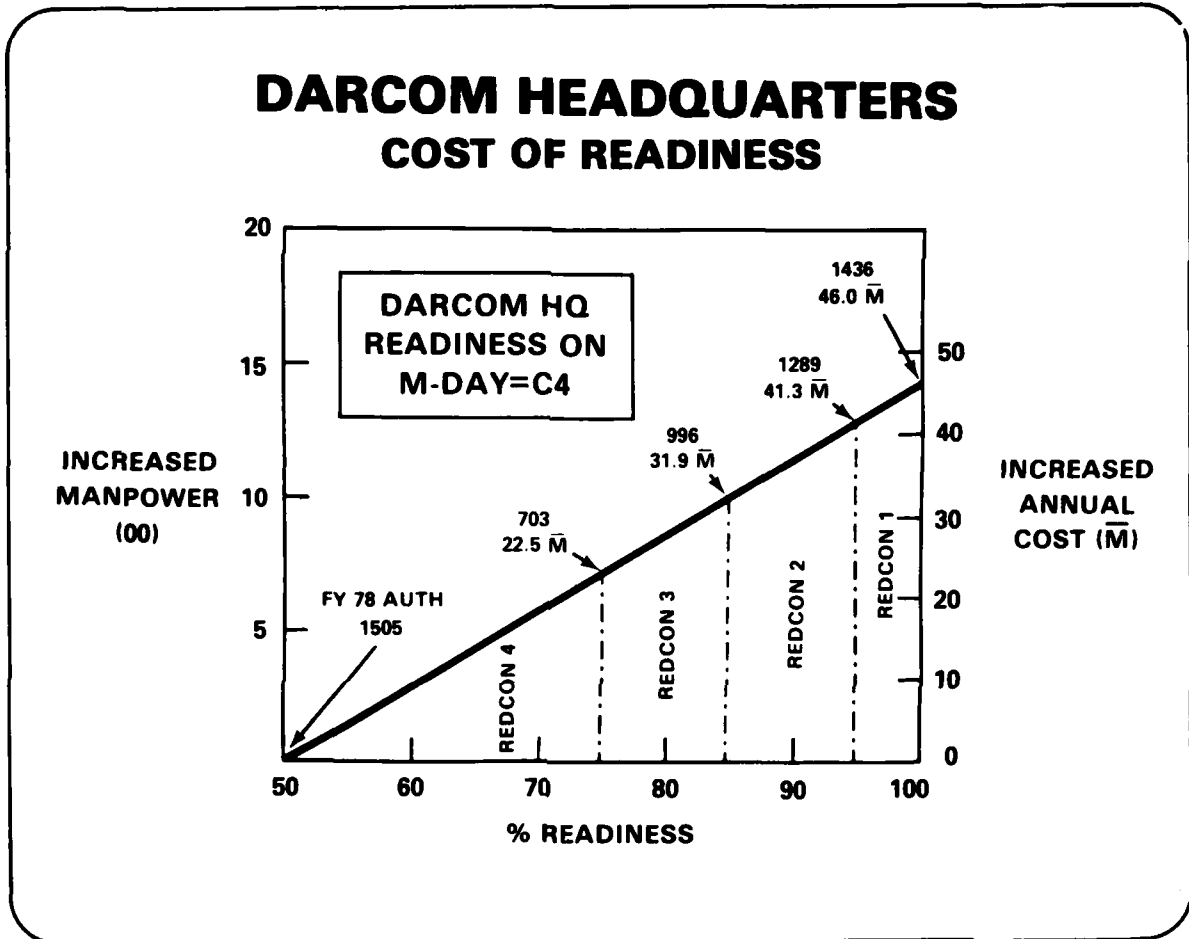

IV-27

TOTAL DARCOM FY 78 AUTHORIZED vs. READINESS

To summarize, Chart IV-28 compares the authorized total DARCOM personnel strength to that strength required to achieve higher level REDCON postures.

Next, we will describe the mobilization requirements assuming the peacetime baseline level of 137,157 is approved.

TOTAL DARCOM FY 78 AUTHORIZED vs READINESS

	FY 78 AUTH	CURRENT REDCON	REDCON 3 (75%) BASELINE SHORTFALL		REDCON 2 (85%) BASELINE SHORTFALL		REDCON 1 (95%) BASELINE SHORTFALL		100% BASELINE SHORTFALL	
MATERIEL READINESS	90479	4	111322	20843	126142	35683	140961	50482	148371	57892
RESEARCH DEVELOPMENT TEST AND EVALUATION	25407	4	26093	686	29524	4117	32955	7548	34670	8263
DARCOM HQ	1505	4	2208	703	2501	996	2794	1269	2941	1438
TOTAL	117,391	4	139623	22232	158167	40776	176710	59319	185982	68591

IV-28

MATERIEL READINESS—COST OF READINESS

Chart IV-29 addresses materiel readiness. Note that with the recommended baseline (106,214) DARCOM materiel readiness would remain at a REDCON 4 status. However, DARCOM materiel readiness would increase from 60% to 71% leaving only 5108 personnel to achieve REDCON 3.

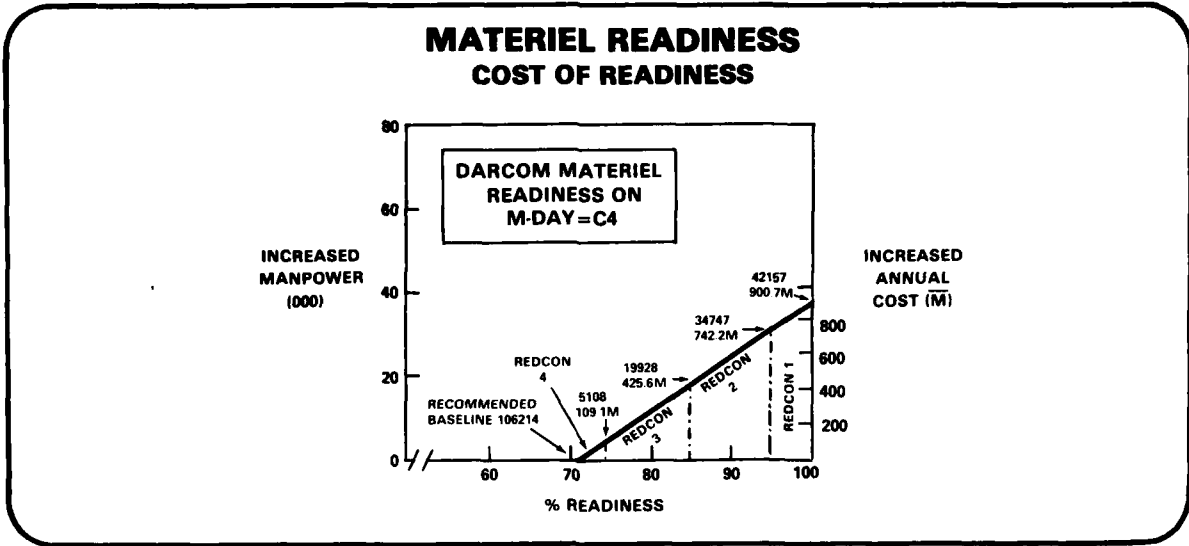

IV-29

RDTE—COST OF READINESS

Similarly for research, development, test and evaluation, the recommended baseline of 29,108 would increase the DARCOM RDTE posture to REDCON 3 (Chart IV-30).

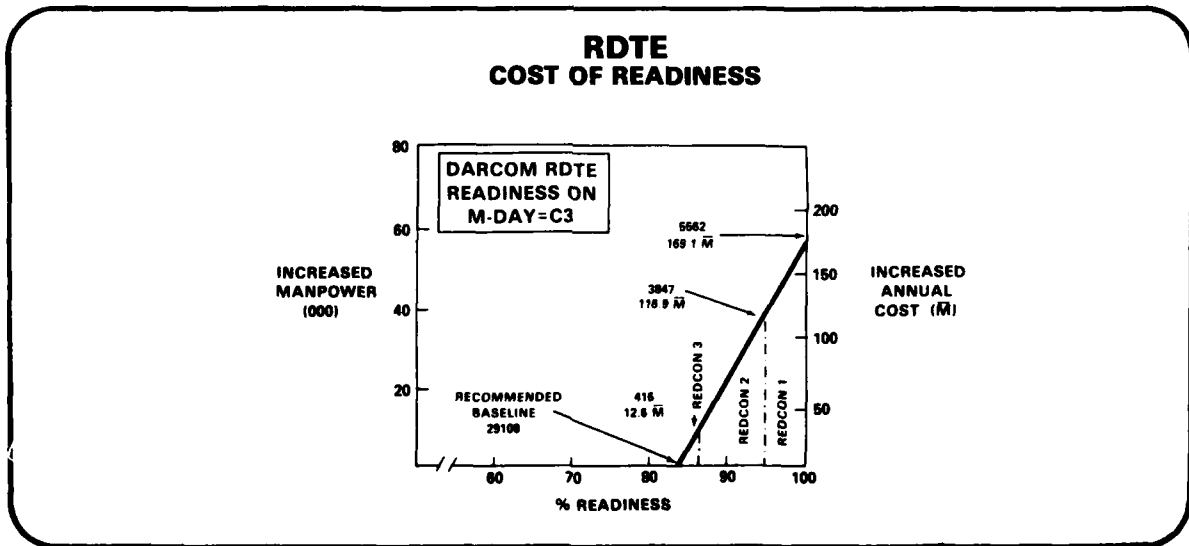

IV-30

DARCOM HQ—COST OF READINESS

Chart IV-31 displays DARCOM HQ requirements. Note that DARCOM HQ would remain in a REDCON 4 status even if staffed at the recommended baseline of 1835. However, the percent of readiness for this element would increase from 50% to 63% leaving a requirement of only 373 personnel and 11.9 million dollars to achieve REDCON 3 status. It is felt that this austere manning level would provide an adequate base for rapid expansion during mobilization.

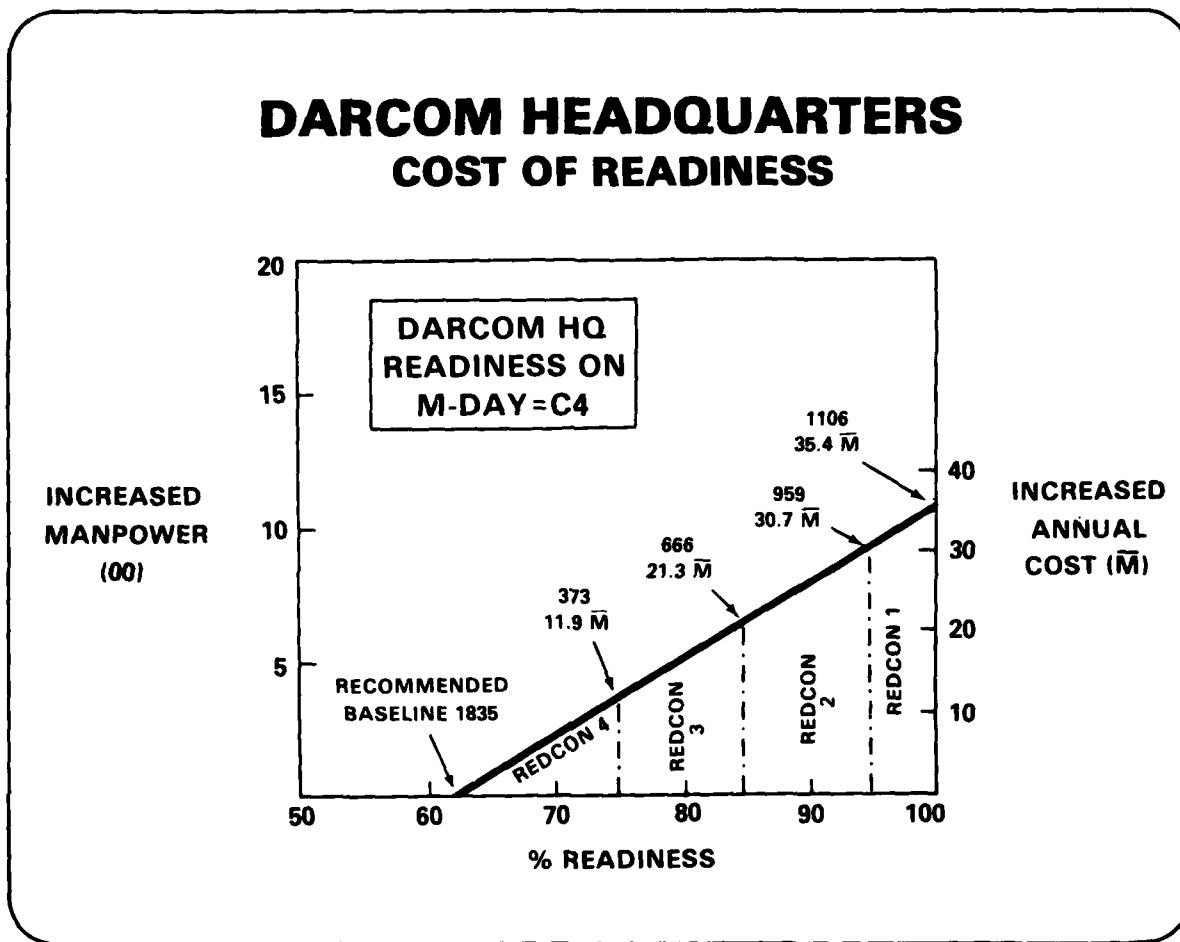

IV-31

TOTAL DARCOM RECOMMENDED BASELINE vs. READINESS

To summarize, Chart IV-32 compares the recommended total DARCOM personnel strength to that strength required to achieve higher level REDCON postures. Note that the total DARCOM recommended baseline of 137,157 would place one mission element and DARCOM as a whole, in a REDCON4 status.

In summary our analysis concludes that a manpower level of 137,157 is required for DARCOM to achieve maximum peacetime efficiency and to provide an adequate mobilization/surge capability. Until this baseline is achieved we will continue to strive for greater productivity and to search for other means to augment our capability to support mobilization requirements.

TOTAL DARCOM RECOMMENDED BASELINE vs READINESS

	RECOM- MEND BASELINE	CURRENT REDCON	REDCON 3 (75%) BASELINE SHORTFALL		REDCON 2 (85%) BASELINE SHORTFALL		REDCON 1 (95%) BASELINE SHORTFALL		100% BASELINE SHORTFALL	
MATERIEL READINESS	106214	4	111322	5108	126142	19928	140961	34747	148371	42157
RESEARCH DEVELOPMENT TEST AND EVALUATION	29108	3	26093	NONE	29524	416	32955	3847	34670	5562
DARCOM HQ	1835	4	2208	373	2501	666	2794	959	2941	1106
TOTAL	137157	4	139623	5481	158167	21010	176710	39553	185982	48825

IV-32

THINGS TO COME

With the assumptions that the Executive and Legislative bodies will continue to remain austere with regard to the Defense budget, and that this country will remain in a period of detente, projections of future requirements on DARCOM are shown on Chart IV-33.

THINGS TO COME

- THE FY 70-72 TECHNOLOGY WILL BE AT LEAST 10 YEARS OLD IN 1980
- THREAT HAS SHARPLY INCREASED SINCE FY 70-72—WILL CONTINUE TO INCREASE
- DARCOM MANAGED ITEMS WILL INCREASE TO APPROXIMATELY 777,000 BY FY 83
- DARCOM REQUISITIONS WILL INCREASE TO APPROXIMATELY 4,500,000 PER YEAR BY FY 83
- NO INCREASE FORECAST FOR MILITARY AND CIVILIAN WORKFORCE
- OMB CIRCULAR A-76 CONTRACTING OUT REVIEWS (FY 80-84)
- DARCOM SUPPORT TO THE FIELD WILL BE WELL BELOW REQUIREMENTS

IV-33

Chart IV-34 dramatically portrays not only the current materiel readiness personnel shortfall, but indicates that DARCOM will be greatly understaffed by FY 83 — based on the influx of new systems and no foreseeable increase in the workforce.

DARCOM MATERIEL READINESS WORKLOADS & PERSONNEL: HISTORICAL AND PROJECTED

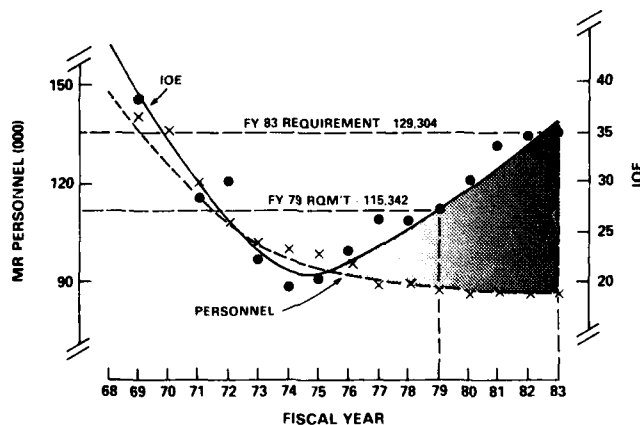

This completes the baseline analysis.

IV-34

SUMMARY

This analysis has traced the declining manpower strength of DARCOM in relation to active Army force structure and other events contributing to increased DARCOM workload.

Performance against established DA goals which reflect Near-Term Readiness is sagging. We have measured procurement execution, the effectiveness of the distribution and equipment maintenance programs and the maintenance of our real property. In all cases, the curves are going the wrong way.

Further, the erosion of our in-house technology base strength, development engineering strength, and in-house test capability impedes our progress toward mid-term modernization. Increasing weapon systems/equipment sophistication warrants an associated increase in our RDTE community. Of particular concern is the squeeze in the number of personnel devoted to pushing technology.

The salary gap between industry and the Federal Government, as it exists for scientists and engineers, makes the Army less competitive today in the market place in trying to hire and retain new people—and we will be less competitive in the future if pay caps are applied.

Despite our success in increasing the amount of work done on contract in support of readiness and development, the in-house workload continues to mount.

We have concluded that to achieve our validated peacetime workload, DARCOM should be authorized 137,157 manpower spaces. To do so would not only achieve peacetime efficiency and effectiveness, but would allow the command to attain a surge mobilization posture in less time.

We need the help of the Army staff in providing the support recommended for DARCOM to play its proper role as the wholesale logistics operator and materiel developer of the U.S. Army.