

AD-A084 180

AD-A084 180

RIA-80-U438

TECHNICAL  
LIBRARY

February 1980

Fluerics 41: Single-Sided Control Port Characteristics  
of Laminar Proportional Amplifiers for Arbitrary Input Loading

by R. Michael Phillippi  
Tadeusz M. Drzewiecki



U.S. Army Electronics Research  
and Development Command  
**Harry Diamond Laboratories**

Adelphi, MD 20783

The findings in this report are not to be construed as an official Department of the Army position unless so designated by other authorized documents.

Citation of manufacturers' or trade names does not constitute an official indorsement or approval of the use thereof.

Destroy this report when it is no longer needed. Do not return it to the originator.

UNCLASSIFIED

SECURITY CLASSIFICATION OF THIS PAGE (When Date Entered)

REPORT DOCUMENTATION PAGE		READ INSTRUCTIONS BEFORE COMPLETING FORM
1. REPORT NUMBER HDL-TR-1901	2. GOVT ACCESSION NO.	3. RECIPIENT'S CATALOG NUMBER
4. TITLE (and Subtitle) Fluerics 41: Single-Sided Control Port Characteristics of Laminar Proportional Amplifiers for Arbitrary Input Loading		5. TYPE OF REPORT & PERIOD COVERED Technical Report
		6. PERFORMING ORG. REPORT NUMBER
7. AUTHOR(s) R. Michael Phillippi Tadeusz M. Drzewiecki		8. CONTRACT OR GRANT NUMBER(s) DA: 1L161102AH44
9. PERFORMING ORGANIZATION NAME AND ADDRESS Harry Diamond Laboratories 2800 Powder Mill Road Adelphi, MD 20783		10. PROGRAM ELEMENT, PROJECT, TASK AREA & WORK UNIT NUMBERS Program Ele: 61.10.2A
11. CONTROLLING OFFICE NAME AND ADDRESS U.S. Army Materiel Development & Readiness Command Alexandria, VA 22333		12. REPORT DATE February 1980
14. MONITORING AGENCY NAME & ADDRESS (if different from Controlling Office)		13. NUMBER OF PAGES 29
		15. SECURITY CLASS. (of this report) Unclassified
		15a. DECLASSIFICATION/DOWNGRADING SCHEDULE
16. DISTRIBUTION STATEMENT (of this Report)  Approved for public release; distribution unlimited.		
17. DISTRIBUTION STATEMENT (of the abstract entered in Block 20, if different from Report)		
18. SUPPLEMENTARY NOTES HDL Project: A44934 DRCMS Code: 611102.H.440011		
19. KEY WORDS (Continue on reverse side if necessary and identify by block number) Fluidic Laminar proportional amplifier Control port characteristic		
20. ABSTRACT (Continue on reverse side if necessary and identify by block number) This report presents a technique for analytically predicting single-sided control port characteristics of a laminar proportional amplifier (LPA) with arbitrary input circuits at the opposite control using calculable differential characteristics. Specific cases dealt with include a constant pressure at the opposite control, a constant flow at the opposite control, and a series and shunt flow resistance at the opposite control.		

UNCLASSIFIED

SECURITY CLASSIFICATION OF THIS PAGE(When Data Entered)

Item 20 (cont'd)

Experiments using amplifiers at various aspect ratios (height-to-width ratio of supply nozzle) and supply pressures, which imply a large range of LPA resistance, show a maximum error of 11 percent between actual and computed single-sided control port flow resistance.

UNCLASSIFIED

SECURITY CLASSIFICATION OF THIS PAGE(When Data Entered)

## CONTENTS

	<i>Page</i>
1. INTRODUCTION .....	5
2. ANALYSIS .....	7
2.1. Constant Pressure on Opposite Control .....	7
2.2. Constant Flow at Control Port C2 .....	10
2.3. Series and Shunt Resistance at Control Port C2 .....	11
3. OBSERVED PERFORMANCE .....	14
4. SUMMARY AND CONCLUSION .....	16
NOMENCLATURE .....	21

## FIGURES

1. HDL Model 3.1.1.8 LPA .....	6
2. LPA differential input characteristics .....	7
3. LPA physical configuration for constant pressure on opposite control .....	8
4. Construction of single-sided characteristic .....	8
5. Construction of single-sided characteristic .....	10
6. LPA physical configuration for series and shunt resistance as control port C2 .....	11
7. Construction of single-sided characteristic .....	12
8. Method for obtaining centered-jet characteristic .....	14
9. Control port 1 (C1) pressure-flow characteristic for $P_{c2} = \text{constant}$ , with $P_s = 0.67$ kPa .....	15
10. Control port 1 (C1) pressure-flow characteristic for $P_{c2} = \text{constant}$ , with $P_s = 0.476$ kPa .....	16
11. Control port 1 (C1) pressure-flow characteristic for $P_{c2} = \text{constant}$ , with $P_s = 0.15$ kPa .....	17
12. Control port 1 (C1) pressure-flow characteristic for $Q_{c2} = \text{constant}$ , with $P_s = 0.67$ kPa .....	18

13.	Control port 1 (C1) pressure-flow characteristic for $Q_{c2} = \text{constant}$ , with $P_s = 0.476$ kPa .....	18
14.	Control port 1 (C1) pressure-flow characteristic for $Q_{c2} = \text{constant}$ , with $P_s = 0.15$ kPa .....	19
15.	Control port 1 (C1) pressure-flow characteristic for series and shunt resistance at control port 2, with $P_s = 0.67$ kPa .....	19
16.	Control port 1 (C1) pressure-flow characteristic for series and shunt resistance at control port 2, with $P_s = 0.46$ kPa .....	20
17.	Control port 1 (C1) pressure-flow characteristic for series and shunt resistance at control port 2, with $P_s = 0.15$ kPa .....	20

## 1. INTRODUCTION

Over the past five years, considerable effort has been expended to analytically determine the differential input or control (pressure-flow) characteristics of laminar proportional amplifiers (LPA's).<sup>1,2</sup> With increasing emphasis on sensing/control systems, however, it has become important to analytically predict single-sided input characteristics for various input circuits at the opposite control. Unfortunately, little or no work has been done along these lines and thus information is unavailable in technical literature. The ability to predict single-sided input characteristics would greatly facilitate the design of many fluidic systems such as fluidic temperature sensors, strain gages, speed sensors, and all devices that operate on the back-pressure principle.

Figure 1 depicts the current state-of-the-art LPA (Harry Diamond Laboratories—HDL—Model 3.1.1.8), which will be the only component considered. With reference to the interaction region (dotted line), it is apparent that if a pressure is applied at control port 1 with control port 2 open to ambient ( $P_{c2} = 0$ ), a deflection of the supply jet would result. Consider now the case where the same pressure is applied at control port 1 while control port 2 is held at constant pressure other than zero ( $P_{c2} = \text{constant}$ ). The amount of jet deflection is now reduced, yielding a new pressure-flow ( $P-Q$ ) relationship for control port 1. This effect is not limited only to constant pressures at the opposite control, but has been observed for constant flows and arbitrary input circuits at port 2 as well.

Analytical expressions are derived for the pressure-flow relationships at control port 1 for three cases: (1) constant pressure on control port 2, (2) constant flow on control port 2, and (3) a series/shunt resistance (as being a representation of some general load) at control port 2. These expressions are derived by use of calculable differential pressure-flow relationships. Experimental verification for various aspect ratios (height-to-width ratio of supply nozzle, denoted by  $\sigma$ ) and supply pressures is presented, followed by the summary and conclusions.

<sup>1</sup> F. M. Manion and T. M. Drzewiecki, Analytical Design of Laminar Proportional Amplifiers, Proceedings of The HDL Fluidic State-of-the-Art Symposium, Vol. 1, Harry Diamond Laboratories (October 1974), 149.

<sup>2</sup> T. M. Drzewiecki, Fluierics 38. A Computer-Aided Design Analysis for the Static and Dynamic Port Characteristics of Laminar Proportional Amplifiers, Harry Diamond Laboratories, HDL-TR-1758, (June 1976).

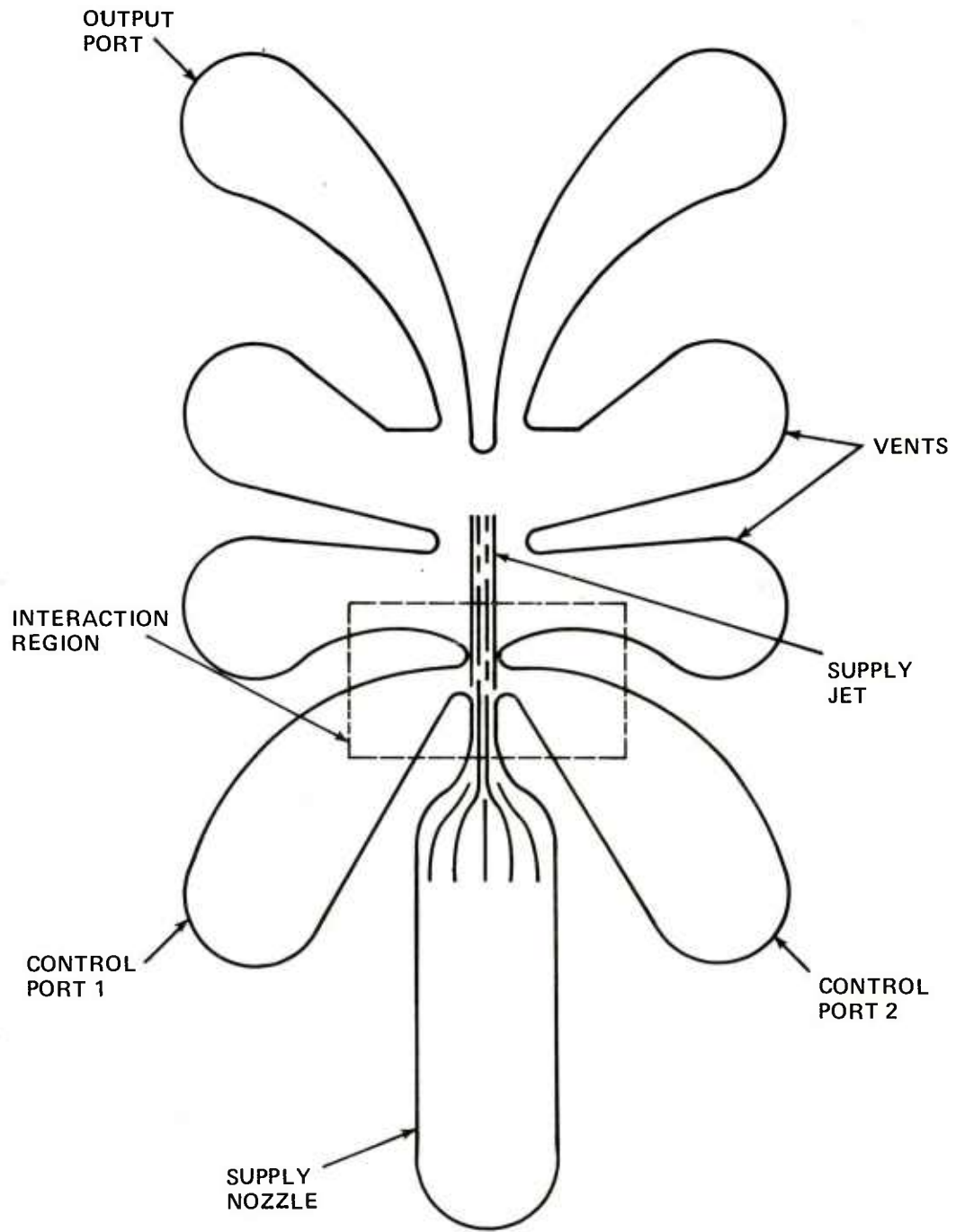

Figure 1. HDL Model 3.1.1.8 LPA.

## 2. ANALYSIS

Recently, a computer algorithm has been developed<sup>2</sup> that can predict differential control port characteristics of LPA's. The analysis presented here is an extension of this previous work in that computed differential characteristics are used as a basis for the derivation of single-sided characteristics. Only the deflected-jet and centered-jet characteristics need be known. These are shown in figure 2.

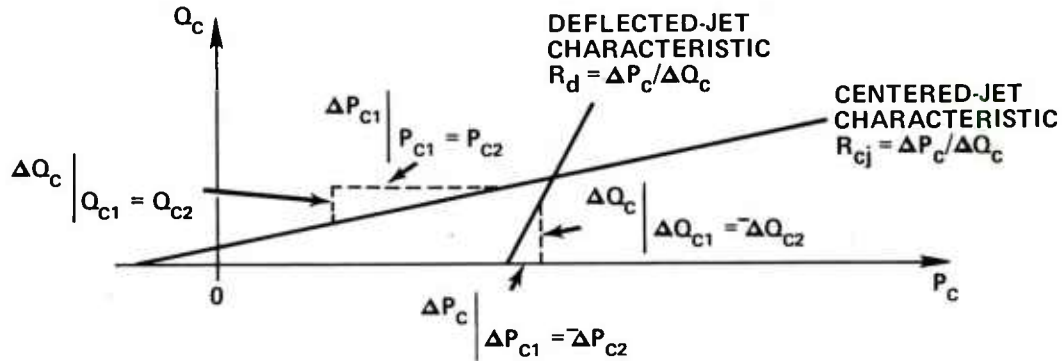

Figure 2. LPA differential input characteristics.

The centered-jet characteristic corresponds to the control port pressure-flow relationship while the supply jet is maintained at its center position. The deflected-jet characteristic, on the other hand, corresponds to the control port pressure-flow relationship as the jet is being deflected with a "push-pull" differential input signal. This, in turn, states that the bias or average control pressure,  $P_b$ , where

$$P_b = \frac{P_{c1} + P_{c2}}{2} , \quad (1)$$

is constant for a given deflected-jet characteristic. Thus, an infinite number of deflected-jet characteristics exist—one for every value of bias pressure,  $P_b$ . Fortunately, however, the inverse slope,  $R_d$ , of the deflected-jet characteristic is nearly constant with bias pressure,  $P_b$ , for  $P_b$  not close to zero. The following analysis assumes that

- (a) Centered-jet and deflected-jet characteristics are linear.
- (b) The inverse slope of the deflected-jet characteristics is constant with bias pressure.
- (c) The derived single-sided characteristic will also be linear.

### 2.1 Constant Pressure on Opposite Control

The physical configuration for this case is shown in figure 3. Here, the pressure-flow ( $P$ - $Q$ ) relationship at control port  $C1$  is desired while control port  $C2$  is held at constant pressure,  $P^*$ .

With the assumption of a linear pressure-flow relationship at  $C1$ , only the inverse slope and

<sup>2</sup> T. M. Drzewiecki, Fluerics 38. A Computer-Aided Design Analysis for the Static and Dynamic Port Characteristics of Laminar Proportional Amplifiers, Harry Diamond Laboratories, HDL-TR-1758, (June 1976).



Now, by increasing the bias pressure to  $2P^*$  while holding  $P_{c2}$  equal to  $P^*$ ,  $P_{c12}$  is found by use of the bias pressure equation

$$P_b = 2P^* = \frac{P_{c12} + P^*}{2} ,$$

or

$$P_{c12} = 3P^*$$

From above, then,  $\Delta P_{c1} = P_{c12} - P_{c11} = 2P^*$ . The quantity  $\Delta Q_{c1} = Q_{c12} - Q_{c11}$  can now be formulated after several intermediate steps. Since  $Q_{c11}$  is already known, only  $Q_{c12}$  need be found. Again, referring to figure 4, it is seen that

$$Q_{c12} = \Delta Q_c - Q_{c22}$$

where

$$\Delta Q_c = \frac{2P^*}{R_d} ,$$

and

$$Q_{c22} = Q_5 - Q_4 ,$$

where

$$Q_5 = \frac{P^*}{R_d}$$

and

$$Q_4 = \frac{2P^* - P_{\text{offset}}}{R_{c1}}$$

The final expression for  $\Delta Q_{c1}$  becomes

$$\Delta Q_{c1} = \frac{P^*(R_{c1} + R_d)}{R_{c1}R_d} ,$$

which yields

$$R_{c1} = \frac{\Delta P_{c1}}{\Delta Q_{c1}} = \frac{2R_{c1}R_d}{R_{c1} + R_d} . \quad (2)$$

The intersection of the  $C1$  curve with the pressure axis can now easily be found to be

$$P_{c1} \Big|_{Q_{c1}=0} = \frac{P^*(R_{c1} - R_{c1}) + R_{c1}P_{\text{offset}}}{R_{c1}} ,$$

thus completing the entire expression,

$$P_{c1} = R_{c1}Q_{c1} + \frac{P^*(R_{c1} - R_{c1}) + R_{c1}P_{\text{offset}}}{R_{c1}} . \quad (3)$$

## 2.2. Constant Flow at Control Port C2

Consider now the case where a constant amount of flow is maintained at C2. This occurs in reality when a very high resistance from a constant pressure is applied. Variations in the control resistance do not materially affect the total resistance; hence, flow is approximately constant. Again, by construction and assumption of linearity, the inverse slope,  $R_{c1}$ , of the  $P-Q$  characteristic can be determined.

The supply jet is initially assumed to be in its centered position, which corresponds to point 1 in figure 5. Pressure-flow coordinates are

$$P_{c11} = Q^* R_{cj} + P_{\text{offset}}$$

and

$$Q_{c11} = Q^* .$$

Now, the bias pressure is increased to  $P_3$  so that the corresponding flow rate is  $2Q^*$  while a constant flow rate of  $Q^*$  is still maintained at control port 2. This defines point 2 such that

$$P_{c12} = P_3 + Q^* R_d$$

where

$$P_3 = P_{c11} + Q^* R_{cj} \quad \text{and} \quad Q_{c12} = 3Q^* .$$

The inverse slope,  $R_{c1}$ , of the control port 1 characteristic can now be formed.

$$R_{c1} = \frac{\Delta P_{c1}}{\Delta Q_{c1}} = \frac{P_3 + Q^* R_d - Q^* R_{cj} - P_{\text{offset}}}{2Q^*}$$

or

$$R_{c1} = \frac{R_{cj} + R_d}{2} . \quad (3)$$

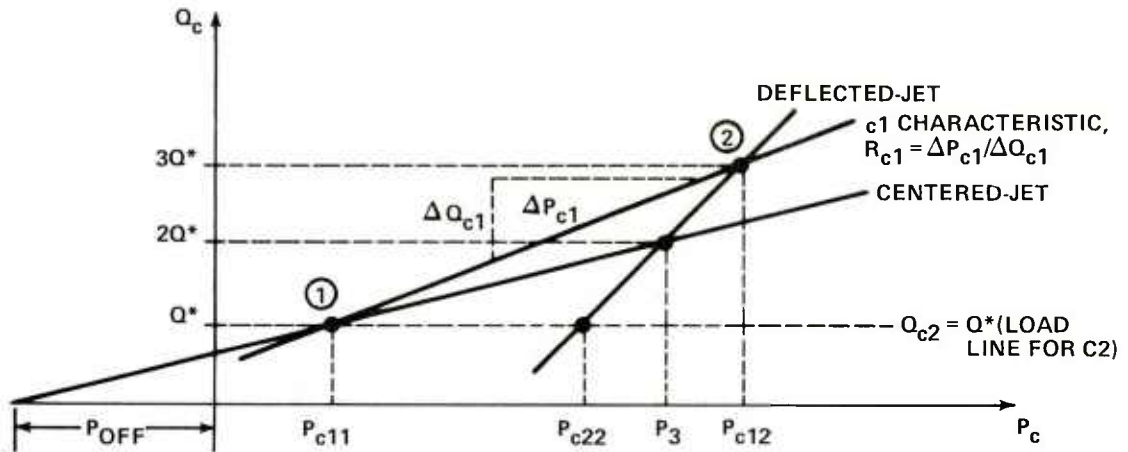

Figure 5. Construction of single-sided characteristic.

Pressure-flow coordinates  $P_{c11}$  and  $Q_{c11}$  are now used to determine the intersection with the pressure axis,

$$b = P_{c11} - Q_{c11}R_{c1}$$

or

$$b = Q^*R_{cj} + P_{\text{offset}} - Q^*R_{c1} \quad ,$$

thus completing the final expression,

$$P_{c1} = Q_{c1}R_{c1} + Q^*(R_{cj} - R_{c1}) + P_{\text{offset}} \quad . \quad (4)$$

### 2.3. Series and Shunt Resistance at Control Port C2

Consider the configuration shown in figure 6.

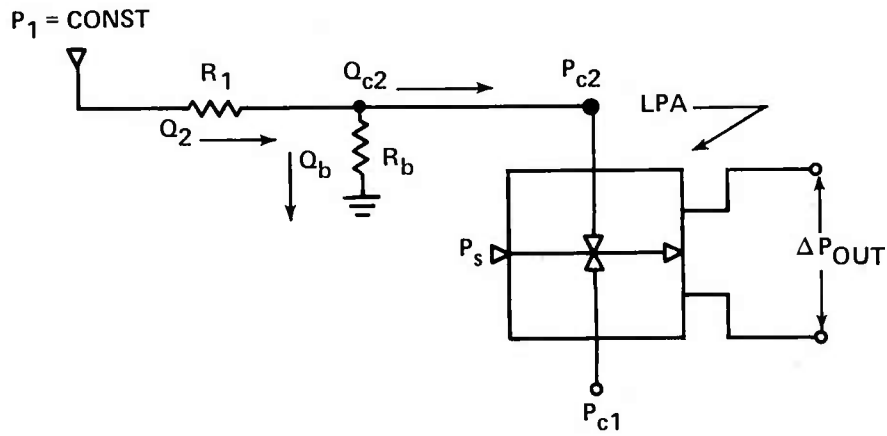

Figure 6. LPA physical configuration for series and shunt resistance at control port C2.

In order to derive an expression for the pressure-flow relationship of control port 1, a load line for control port 2 is first constructed (fig. 7). From continuity it is seen that

$$Q_2 = Q_b + Q_{c2} \quad ,$$

where

$$Q_2 = \frac{P_1 - P_{c2}}{R_1} \quad \text{and} \quad Q_b = \frac{P_{c2}}{R_b}$$

or

$$Q_{c2} = \frac{P_1 - P_{c2}}{R_1} - \frac{P_{c2}}{R_b} \quad , \quad (5)$$

thus defining the  $P$ - $Q$  relationship for control port 2. Since point 1 lies on the jet-centered curve,  $P_{c1} = P_{c2}$  and  $Q_{c1} = Q_{c2}$ , equating the flows yields

$$\frac{P_{c1} - P_{\text{offset}}}{R_{cj}} = \frac{P_1 - P_{c2}}{R_1} - \frac{P_{c2}}{R_b} \quad .$$

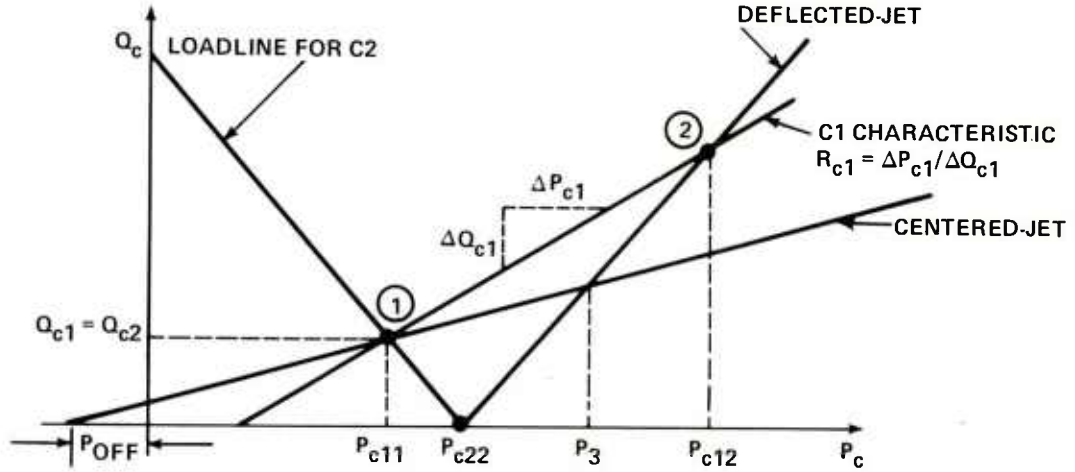

Figure 7. Construction of single-sided characteristic.

However,

$$P_{c1} = P_{c2} \quad ;$$

hence,

$$\frac{P_{c1} - P_{offset}}{R_{cj}} = \frac{P_1 - P_{c1}}{R_1} - \frac{P_{c1}}{R_b}$$

or

$$P_{c11} = \frac{P_1}{R_1 \left( \frac{1}{R_{cj}} + \frac{1}{R_1} + \frac{1}{R_b} \right)} + \frac{P_{offset}}{R_{cj} \left( \frac{1}{R_{cj}} + \frac{1}{R_1} + \frac{1}{R_b} \right)}$$

and

$$Q_{c11} = \frac{P_{c11} - P_{offset}}{R_{cj}} \quad ,$$

thus defining point 1. Once again the bias pressure is increased and the jet is deflected so that  $P_{c22}$  is the intersection of the deflected jet characteristic, the load line for C2, and the pressure axis (this can be done for convenience without any loss of generality).  $P_{c12}$  can now be solved for with the use of the constant bias conditions on the deflected-jet curve,

$$P_3 = \frac{P_{c22} + P_{c12}}{2}$$

or

$$P_{c12} = 2P_3 - P_{c22} \quad (6)$$

$P_{c22}$  is obtained from equation 5 with  $Q_{c2} = 0$ .

$$P_{c22} = \frac{P_1 R_b}{R_b + R_1} \quad (7)$$

$P_3$  is obtained by solving the centered-jet and deflected-jet characteristics simultaneously.

$$\frac{P_3 - P_{\text{offset}}}{R_{cj}} = \frac{P_3}{R_d} - \frac{P_1 R_b}{(R_b + R_1) R_d}$$

or

$$P_3 = \frac{P_{\text{offset}} R_d}{R_{cj} \left( \frac{R_d}{R_{cj}} - 1 \right)} - \frac{P_1 R_b}{(R_b + R_1) \left( \frac{R_d}{R_{cj}} - 1 \right)} \quad (8)$$

With equation 6,  $P_{c12}$  is found to be

$$P_{c12} = \frac{P_1 R_b \left( 1 + \frac{R_d}{R_{cj}} \right)}{(R_b + R_1) \left( 1 - \frac{R_d}{R_{cj}} \right)} - \frac{2 R_d P_{\text{offset}}}{R_{cj} \left( 1 - \frac{R_d}{R_{cj}} \right)} \quad (9)$$

$Q_{c12}$  can now be obtained by the use of the equation of the deflected-jet curve,

$$P_{c12} = R_d Q_{c12} + P_{c22}$$

From this,

$$Q_{c12} = \frac{P_{c12} - P_{c22}}{R_d} = \frac{(2P_3 - P_{c22}) - P_{c22}}{R_d} = \frac{2(P_3 - P_{c22})}{R_d}$$

or

$$Q_{c12} = \frac{2P_1 R_b}{R_{cj} (R_b + R_1) \left( 1 - \frac{R_d}{R_{cj}} \right)} - \frac{2P_{\text{offset}}}{R_{cj} \left( 1 - \frac{R_d}{R_{cj}} \right)} \quad (10)$$

With two  $P$ - $Q$  coordinates known,  $R_{c1}$ , the inverse slope of the  $C1$  characteristic, is formed.

$$R_{c1} = \frac{\Delta P_{c1}}{\Delta Q_{c1}} = \frac{P_{c12} - P_{c11}}{Q_{c12} - Q_{c11}} \quad (11)$$

where

$$P_{c12} = \frac{P_1 R_b \left( 1 + \frac{R_d}{R_{cj}} \right)}{(R_b + R_1) \left( 1 - \frac{R_d}{R_{cj}} \right)} - \frac{2 R_d P_{\text{offset}}}{R_{cj} \left( 1 - \frac{R_d}{R_{cj}} \right)} \quad (11a)$$

$$P_{c11} = \frac{P_1}{R_1 \left( \frac{1}{R_{cj}} + \frac{1}{R_b} + \frac{1}{R_1} \right)} + \frac{P_{\text{offset}}}{R_{cj} \left( \frac{1}{R_{cj}} + \frac{1}{R_1} + \frac{1}{R_b} \right)} \quad (11b)$$

$$Q_{c12} = \frac{2P_1 R_b}{R_{cj} (R_b + R_1) \left( 1 - \frac{R_d}{R_{cj}} \right)} - \frac{2P_{\text{offset}}}{R_{cj} \left( 1 - \frac{R_d}{R_{cj}} \right)} \quad (11c)$$

$$Q_{c11} = \frac{P_1}{R_{cj}R_1\left(\frac{1}{R_{cj}} + \frac{1}{R_1} + \frac{1}{R_b}\right)} + \frac{\left[1 - R_{cj}\left(\frac{1}{R_{cj}} + \frac{1}{R_1} + \frac{1}{R_b}\right)\right]}{R_{cj}^2\left(\frac{1}{R_{cj}} + \frac{1}{R_1} + \frac{1}{R_b}\right)} P_{\text{offset}} \quad (11d)$$

The pressure axis intercept is now determined by substitution of the expressions for  $P_{c11}$  and  $Q_{c11}$  into the equation

$$b = P_{c11} - R_c Q_{c11} \quad (12)$$

Thus, the complete equation becomes

$$P_{c1} = Q_{c1}R_{c1} + (P_{c11} - R_{c1}Q_{c11}) \quad (13)$$

with the corresponding quantities defined in equations 11a to d.

### 3. OBSERVED PERFORMANCE

In order to verify the foregoing analysis, the centered-jet and deflected-jet characteristics were first experimentally determined. Figure 8 shows the technique for obtaining the centered-jet curve.

By applying flow to controls 1 and 2 in a common-mode fashion, the supply jet remains nominally centered. Thus, the requirement that  $P_{c1} = P_{c2}$  and  $Q_{c1} = Q_{c2} = \frac{1}{2}Q_{c\text{tot}}$  is satisfied. The deflected-jet characteristic, on the other hand, must satisfy the requirement that

$$P_b = \frac{P_{c1} + P_{c2}}{2} = \text{constant} \quad ,$$

for all points on the curve. With the assumption of linear characteristics, only two points need be obtained to determine the deflection resistance (inverse slope),  $R_d$ . Since  $R_d$  is constant with bias pressure,  $P_b$ , values for  $P_b$  at which  $R_d$  is determined were arbitrarily selected over a range of 5 to 15 percent of supply pressure. Once a bias pressure is selected, the first point is found on the centered-jet curve where  $P_{c1} = P_{c2} - P_b$ . The  $P$ - $Q$  characteristic is now determined for control port 1 with control port 2 open to ambient ( $P_{c2} = 0$ ). Again, the intersection of the

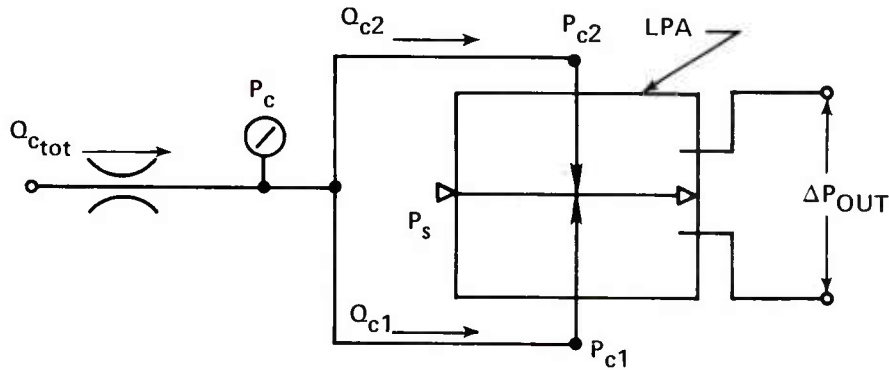

Figure 8. Method for obtaining centered-jet characteristic.

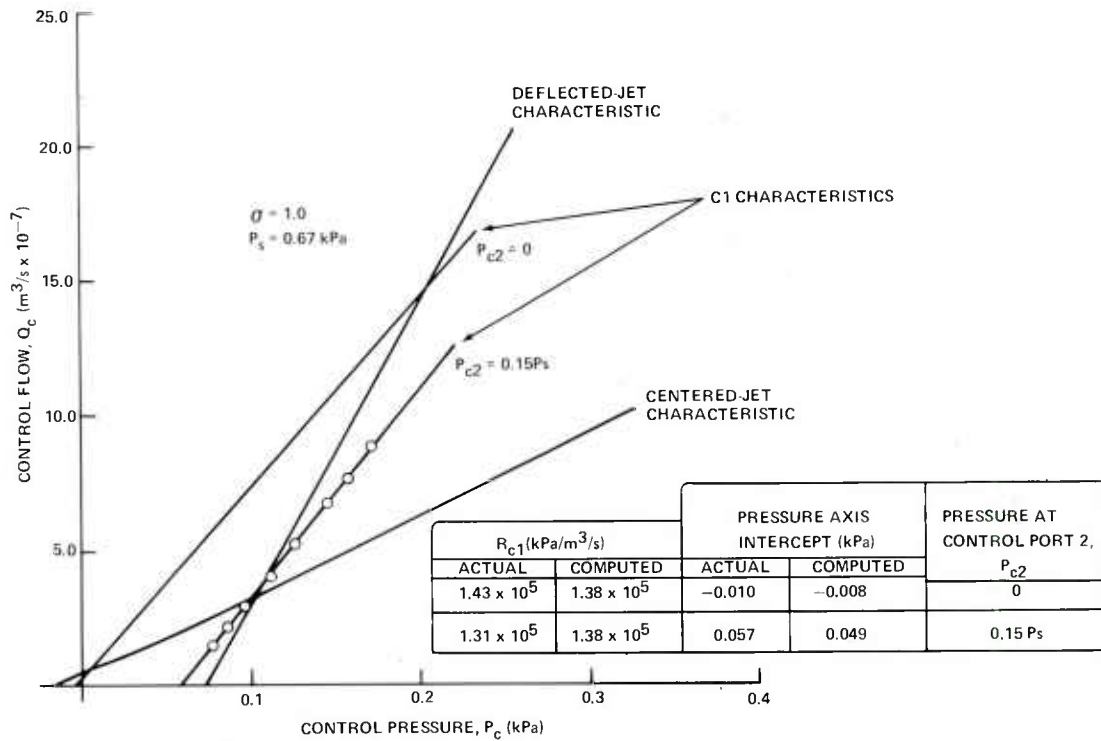

Figure 9. Control port 1 (C1) pressure flow characteristic for  $P_{c2} = \text{constant}$ , with  $P_s = 0.67$  kPa.

deflected-jet curve with the  $P_{c2} = 0$  curve must satisfy

$$P_b = \frac{P_{c1} + P_{c2}}{2} = \frac{P_{c1}}{2} \text{ for } P_{c2} = 0$$

Thus, the second point is quickly determined to be where  $P_{c1} = 2P_b$  on the  $P_{c2} = 0$  curve: All deflected-jet characteristics presented here were determined in the manner outlined above. It should be noted that both  $R_{c1}$  and  $R_d$  may be computed<sup>2</sup> for a general design.

Experimental data for the three cases shown in section 2 at various aspect ratios (height-to-width ratio of supply nozzle, denoted by  $\sigma$ ) and supply pressures appear in figures 9 through 17. For a constant pressure on control port 2 (fig. 9 to 11) the inverse slope,  $R_{c1}$ , of the C1 characteristics is seen to be in good agreement with predicted performance, exhibiting a maximum deviation from experiment of 11 percent. Good agreement between experimentally determined values of  $R_{c1}$  and predicted values can also be seen for a constant flow rate at control port 2 (fig. 12 to 14). Here the error did not exceed 8 percent. Lastly, predicted and experimental values of  $R_{c1}$  for a series and shunt resistance at control port 2 agree reasonably well (11-percent maximum error) as can be seen in figures 15 to 17. Actual and computed pressure axis intercepts differed significantly in many cases, however. The reason for this becomes apparent upon inspection of

<sup>2</sup> T. M. Drzewiecki, Fluorics 38. A Computer-Aided Design Analysis for the Static and Dynamic Port Characteristics of Laminar Proportional Amplifiers, Harry Diamond Laboratories, HDL-TR-1758, (June 1976).

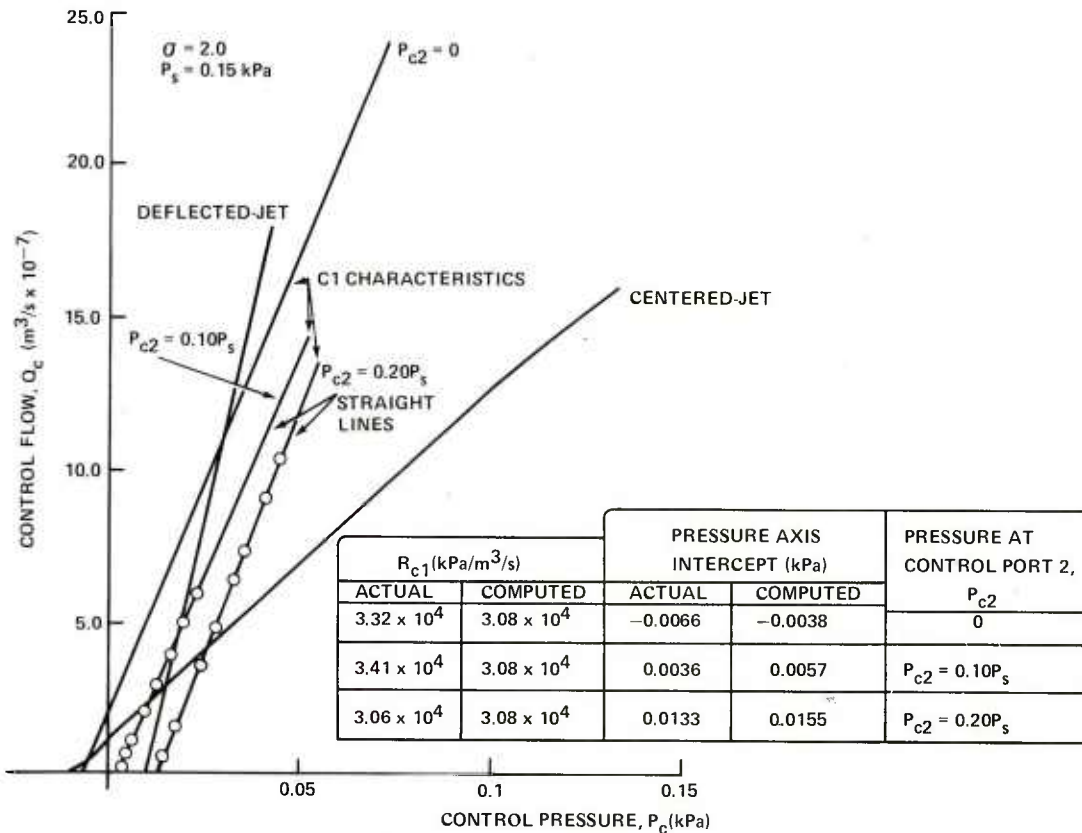

Figure 10. Control port 1 (C1) pressure flow characteristic for  $P_{c2} = \text{constant}$ , with  $P_s = 0.476$  kPa.

the centered-jet characteristics. As mentioned previously, all characteristics were assumed to be straight lines. This assumption is violated for points on the centered-jet curve near zero, due to nonlinearity. Nonetheless, actual values of  $P_{\text{offset}}$  (intersections of centered-jet curve and pressure axis) were used in the computation. If a straight-line tangent were drawn on the centered-jet curve, an "apparent" pressure axis intercept could be determined that would provide better agreement. For  $P_{c2} = 0$  in figures 9, 10, and 11, the nonlinear nature of the  $P_{c2} = 0$  characteristics near zero was responsible for additional error. This effect is particularly pronounced in figure 10, where actual and computed pressure axis intercepts differed by nearly 60 percent. Again, construction of an "apparent" intercept improves accuracy considerably.

#### 4. SUMMARY AND CONCLUSIONS

Coupled with an existing computer algorithm for predicting differential control port characteristics, a purely analytical approach was presented for modeling single-sided control port characteristics. Three specific cases were dealt with—constant pressure on control port 2, constant flow on control port 2, and a series/shunt resistance connected to control port 2. Predicted and experimental values of  $R_{c1}$  (inverse slope of C1 characteristic) agreed well (11-percent maximum error) for the range of aspect ratios and supply pressures tested. Significant error, however, was encountered between experimental and computed values of the C1 characteristic

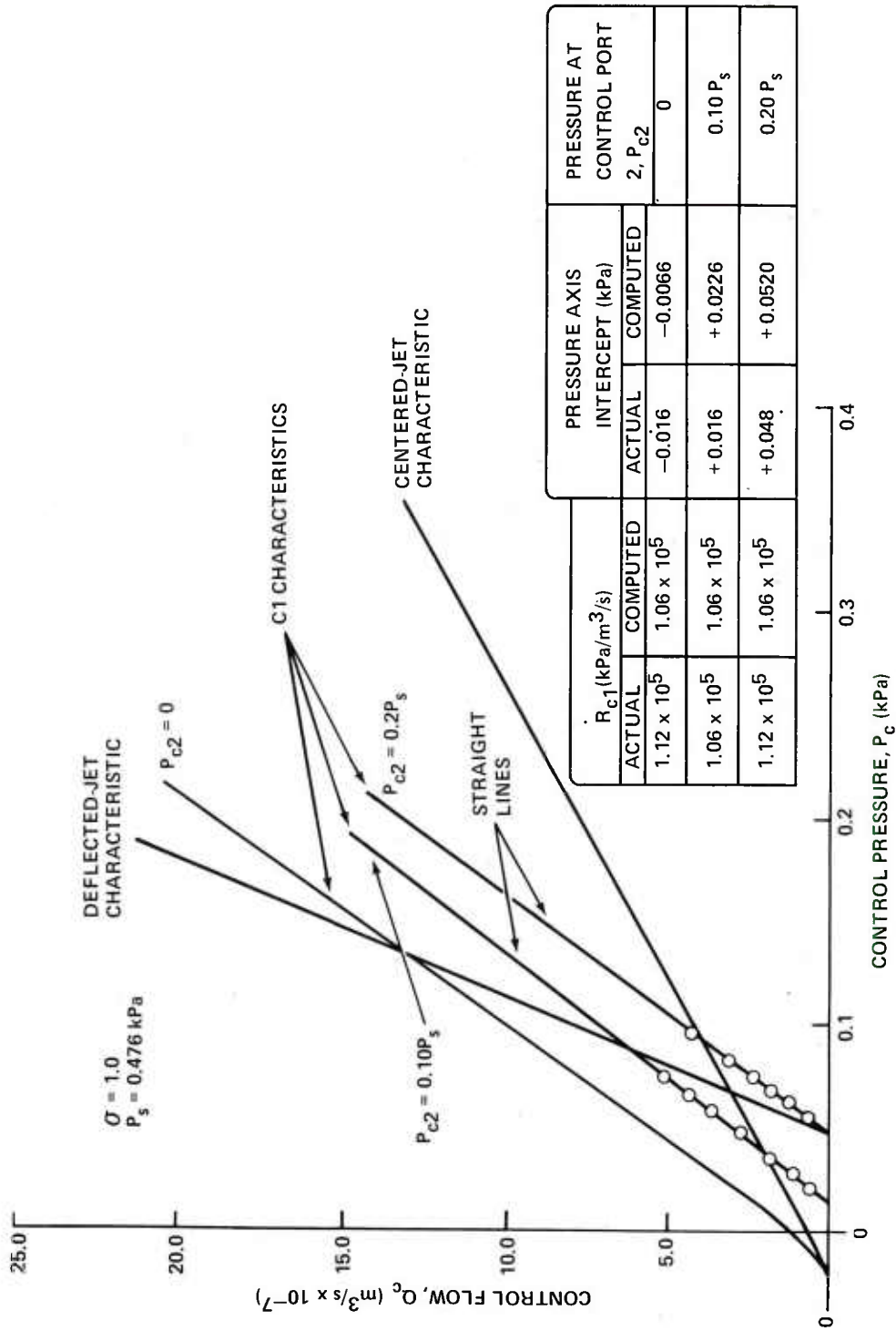

Figure 11. Control port I (C1) pressure-flow characteristic for  $P_{c2} = \text{constant}$ , with  $P_s = 0.15 \text{ kPa}$ .

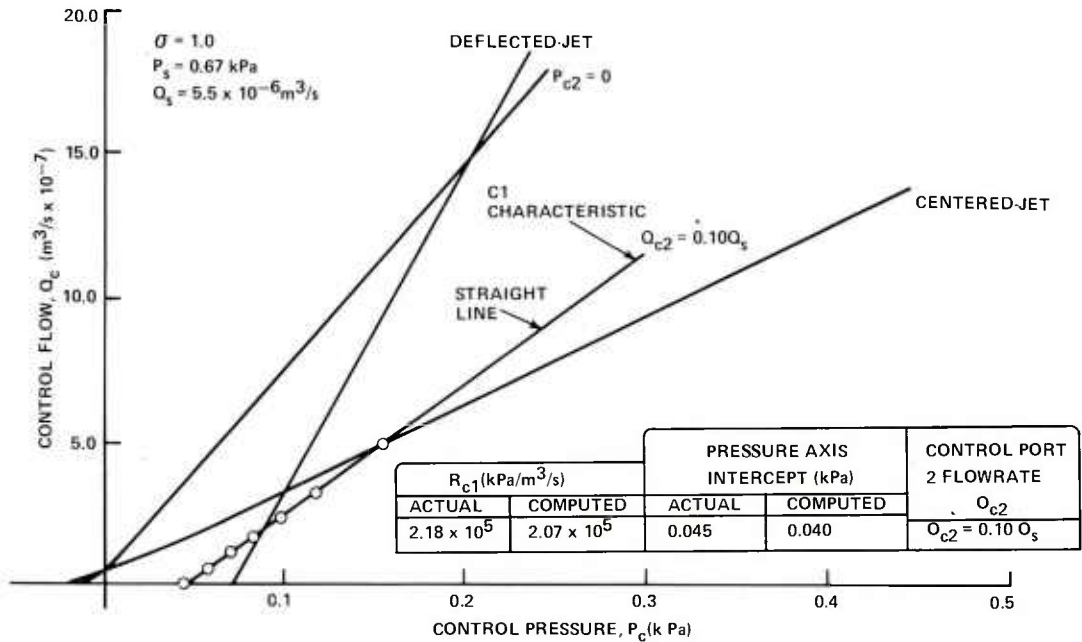

Figure 12. Control port 1 (C1) pressure-flow characteristic for  $Q_{c2} = \text{constant}$ , with  $P_s = 0.67$  kPa.

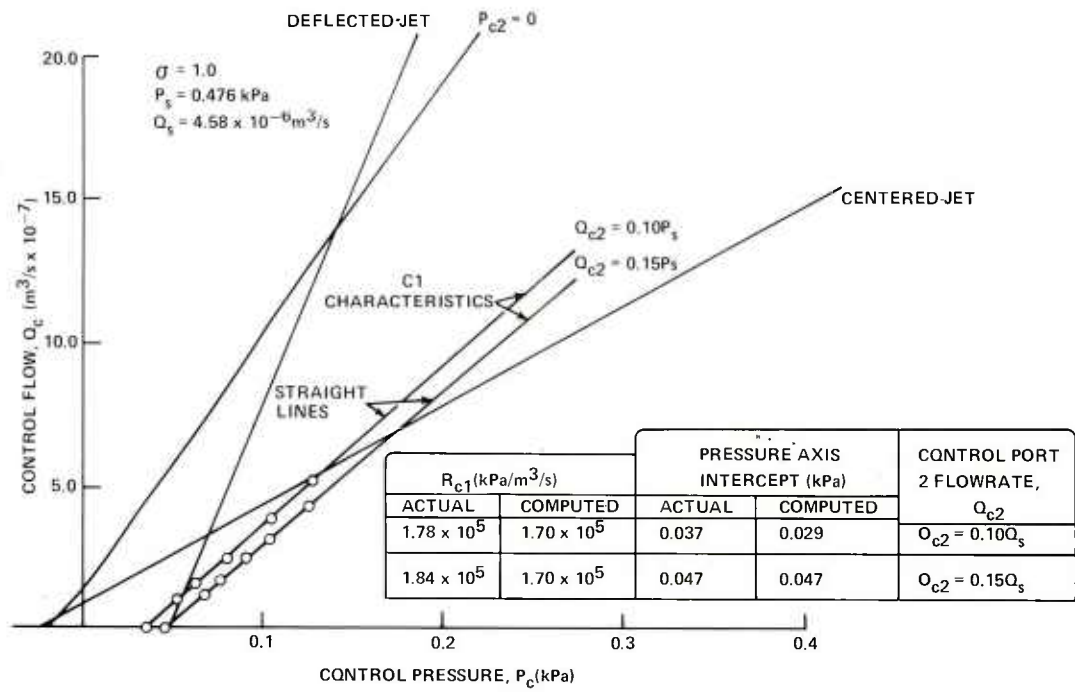

Figure 13. Control port 1 (C1) pressure-flow characteristic for  $Q_{c2} = \text{constant}$ , with  $P_s = 0.476$  kPa.

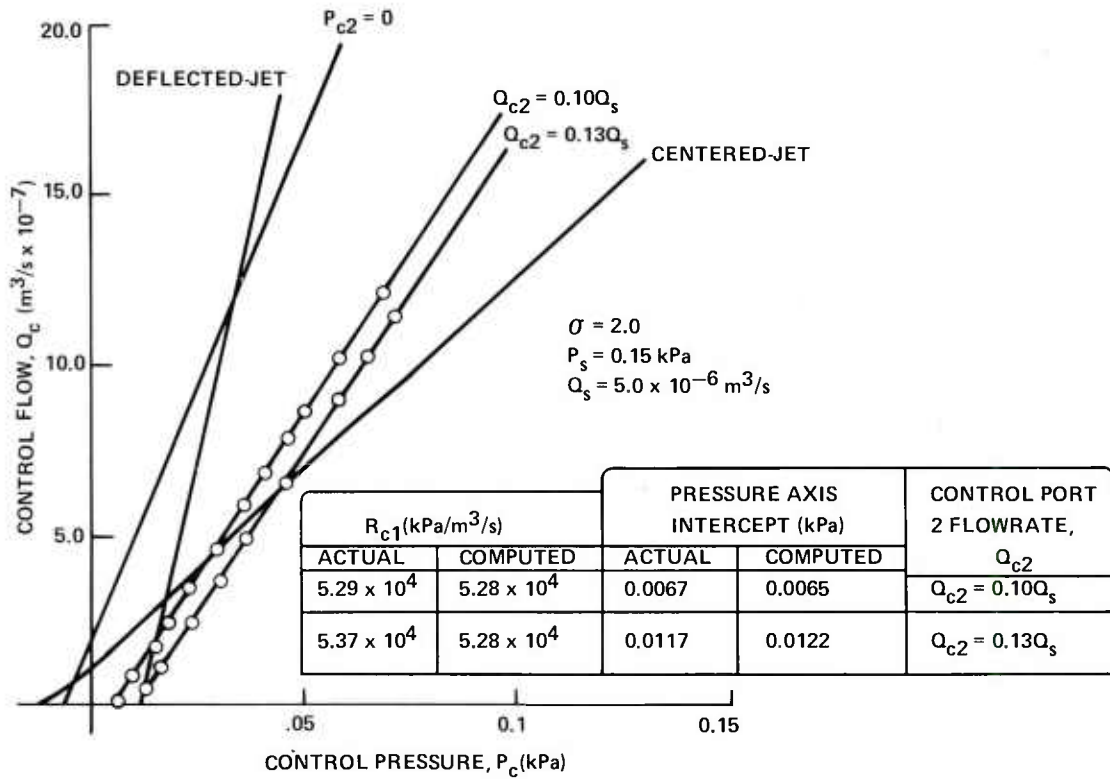

Figure 14. Control port 1 (C1) pressure-flow characteristic for  $Q_{c2} = \text{constant}$ , with  $P_s = 0.15$  kPa.

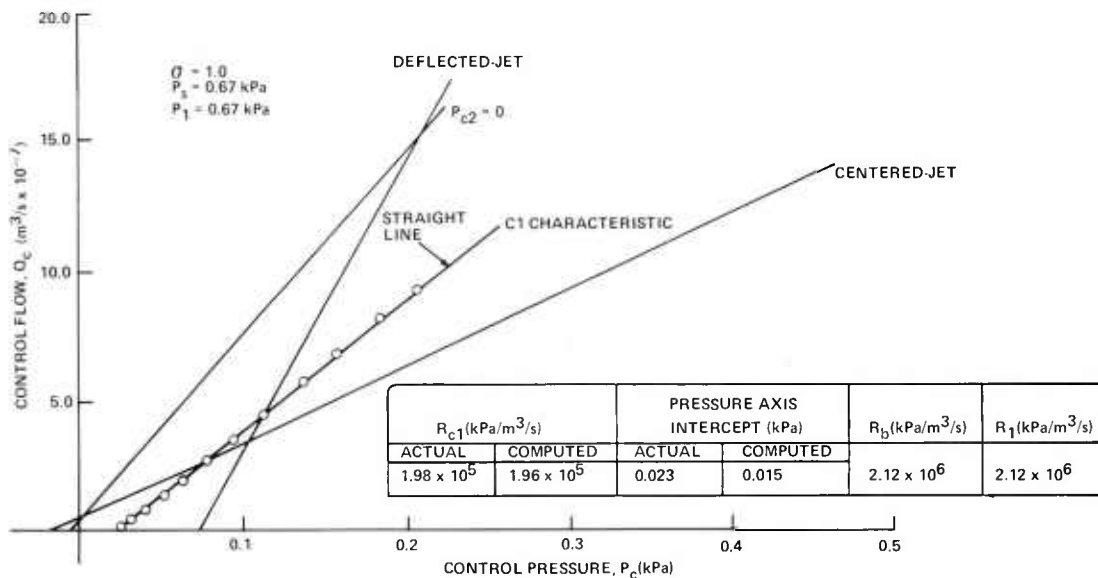

Figure 15. Control port 1 (C1) pressure-flow characteristic for series and shunt resistance at control port 2, with  $P_s = 0.67$  kPa.

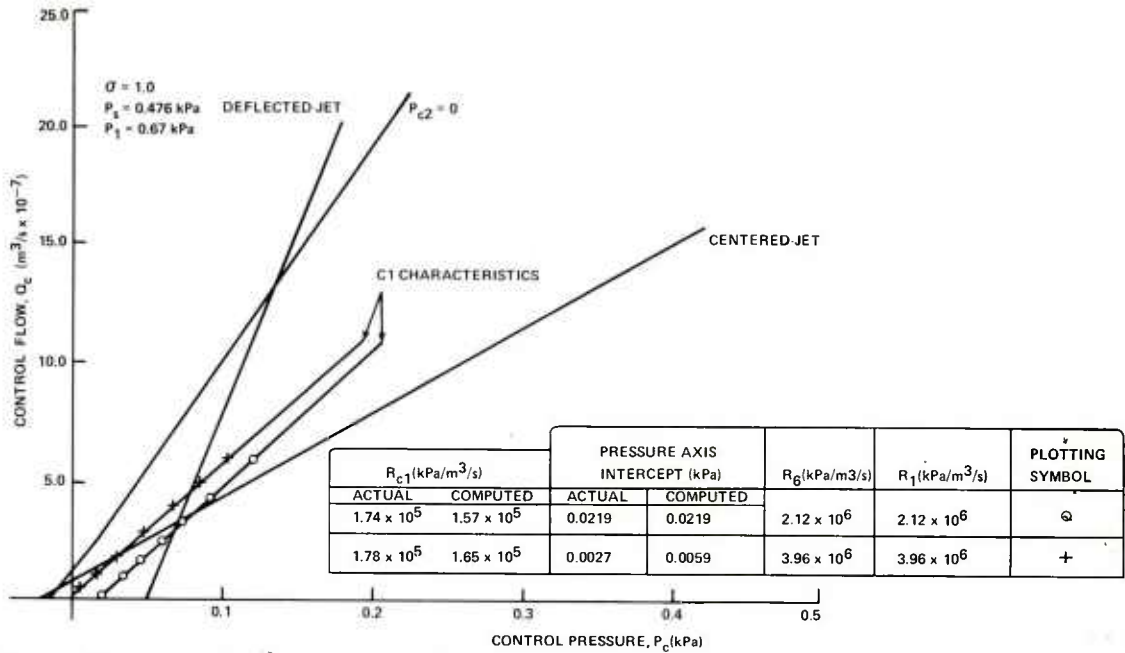

Figure 16. Control port 1 (C1) pressure-flow characteristic for series and shunt resistance at control port 2, with  $P_s = 0.476$  kPa.

pressure axis intercept. This is due, at least in part, to the nonlinear behavior of the centered-jet curve near zero. Better agreement could be obtained through the use of a straight-line or "apparent" pressure axis intercept ( $P_{offset}$ ) for the centered-jet characteristic. In practice, however, the inverse slope,  $R_{c1}$ , of the C1 characteristic is generally of more importance than the pressure axis intercept.

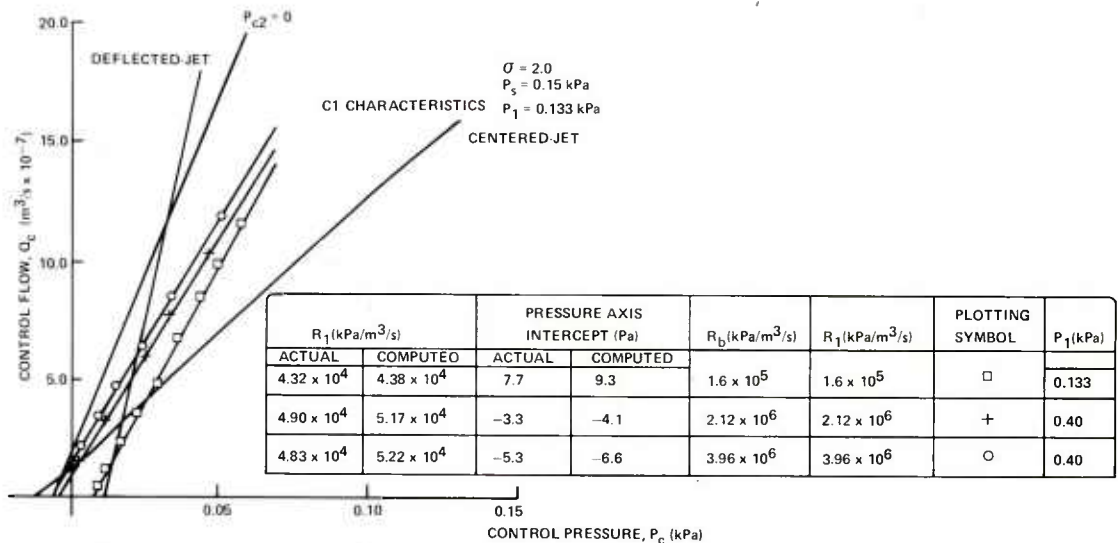

Figure 17. Control port 1 (C1) pressure-flow characteristic for series and shunt resistance at control port 2, with  $P_s = 0.15$  kPa.

From the results obtained, it would appear that the analytical approach is of a general nature. If a load line can be constructed for control port 2, then the C1 characteristic can be determined. This could be extended to the most general case, where orifices (nonlinear resistances) are present at control port 2, thus allowing purely analytical design for any configuration.

### NOMENCLATURE

<i>b</i>	pressure axis intercept of C1 characteristic
C1	control port 1
C2	control port 2
<i>P</i>	pressure ( <i>kPa</i> )
<i>Q</i>	volumetric flow ( $m^3/s$ )
<i>R</i>	fluid resistance $P/Q(kPa/m^3/s)$
$\sigma$	aspect ratio (height-to-width ratio of supply nozzle)

#### Subscripts

<i>b</i>	bias
<i>cj</i>	centered-jet
<i>c1</i>	control port 1
<i>c2</i>	control port 2
<i>d</i>	deflected-jet
offset	pressure axis intercept of the centered-jet curve
tot	total

#### Superscripts

*	constant quantity
---	-------------------

DISTRIBUTION

ADMINISTRATOR  
DEFENSE DOCUMENTATION CENTER  
ATTN DDC-TCA (12 COPIES)  
CAMERON STATION, BUILDING 5  
ALEXANDRIA, VA 22314

COMMANDER  
US ARMY RSCH & STD GP (EUR)  
ATTN LTC JAMES M. KENNEDY, JR.  
CHIEF, PHYSICS & MATH BRANCH  
FPO NEW YORK 09510

COMMANDER  
US ARMY MATERIEL DEVELOPMENT &  
READINESS COMMAND  
ATTN DRXAM-TL, HQ TECH LIBRARY  
ATTN DRCRD-TP, WILLIAM RALPH  
5001 EISENHOWER AVENUE  
ALEXANDRIA, VA 22333

COMMANDER  
US ARMY ARMAMENT MATERIEL  
READINESS COMMAND  
ATTN DRSAR-ASF, FUZE &  
MUNITIONS SUPPORT DIV  
ATTN DRSAR-RDF, SYS DEV DIV - FUZES  
ATTN DRSAR-RDG-T, MR. R. SPENCER  
ATTN DRSAR-ASF  
ATTN DRSAR-LEP-L, TECH LIBRARY  
ROCK ISLAND, IL 61299

COMMANDER  
US ARMY MISSILE & MUNITIONS  
CENTER & SCHOOL  
ATTN ATSK-CTD-F  
REDSTONE ARSENAL, AL 35809

DIRECTOR  
US ARMY MATERIEL SYSTEMS  
ANALYSIS ACTIVITY  
ATTN DRXSY-MP  
ABERDEEN PROVING GROUND, MD 21005

DIRECTOR  
US ARMY BALLISTIC RESEARCH LABORATORY  
ATTN DRDAR-TSB-S (STINFO)  
ABERDEEN PROVING GROUND, MD 21005

TELEDYNE BROWN ENGINEERING  
CUMMINGS RESEARCH PARK  
ATTN DR. MELVIN L. PRICE, MS-44  
HUNTSVILLE, AL 35807

COMMANDER IDDR&E  
PENTAGON, ROOM 3D 1089  
WASHINGTON, DC 20310  
ATTN LTC G. KOPESAK

OFFICE OF THE DEPUTY CHIEF OF STAFF FOR  
RESEARCH, DEVELOPMENT & ACQUISITION  
DEPARTMENT OF THE ARMY  
WASHINGTON, DC 20310  
ATTN DAMA-ARP-P  
ATTN MR. JOHN HILL, ROOM 3D424

US ARMY R&D GROUP (EUROPE)  
BOX 15  
FPO NEW YORK 09510  
ATTN CHIEF, AERONAUTICS BRANCH  
ATTN CHIEF, ENGINEERING SCIENCES

US ARMY RESEARCH OFFICE  
P. O. BOX 12211  
RESEARCH TRIANGLE PARK, NC 27709  
ATTN JAMES J. MURRAY, ENG SCI DIV  
ATTN R. SINGLETON

BMD ADVANCED TECHNOLOGY CENTER  
P.O. BOX 1500  
HUNTSVILLE, AL 35807  
ATTN J. PAPADOPOULOS

COMMANDER  
USA FOREIGN SCIENCE & TECHNOLOGY CENTER  
FEDERAL OFFICE BUILDING  
220 7th STREET, NE  
CHARLOTTESVILLE, VA 22901  
ATTN DRXST-SD1  
ATTN DRXST-IS3, C. R. MOORE

DIRECTOR  
APPLIED TECHNOLOGY LABORATORY  
FORT EUSTIS, VA 23604  
ATTN GEORGE W. FOSDICK, DAVDL-EU-SYA

COMMANDER  
USA MISSILE COMMAND  
REDSTONE ARSENAL, AL 35809  
ATTN REDSTONE SCIENTIFIC INFORMATION  
CENTER, DRSMI-RBD  
ATTN DRDMI-TGC, WILLIAM GRIFFITH  
ATTN DRDMI-TGC, J. C. DUNAWAY  
ATTN DRCPM-TOE, FRED J. CHEPLEN

COMMANDER  
USA MOBILITY EQUIPMENT R&D CENTER  
FORT BELVOIR, VA 22060  
ATTN TECHNICAL LIBRARY (VAULT)  
ATTN DRDME-EM, R. N. WARE

COMMANDER  
EDGEWOOD ARSENAL  
ABERDEEN PROVING GROUND, MD 21010  
ATTN SAREA-MT-T, MR. D. PATTON

DISTRIBUTION (Cont'd)

COMMANDER  
US ARMY ARRADCOM  
DOVER, NJ 07801  
ATTN SARPA-TS-S-#59  
ATTN DRDAR-LCN-F, A. E. SCHMIDLIN  
ATTN DRDAR-LCW-E, MR. J. CONNOR  
ATTN SARPA-ND-C-C, D. SAMPAR

COMMANDER  
WATERVLIET ARSENAL  
WATERVLIET ARSENAL, NY 12189  
ATTN SARWV-RDT-L  
ATTN GARY WOODS  
ATTN JOHN BARRETT

COMMANDER  
USA TANK AUTOMOTIVE RES & DEV COMMAND  
ARMOR & COMP DIV, DRDTA-RKT  
BLDG 215  
WARREN, MI 48090  
ATTN T. KOZOWYK  
ATTN M. STEELE

COMMANDER  
WHITE SANDS MISSILE RANGE, NM 88002  
ATTN STEWS-AD-L, TECHNICAL LIBRARY

COMMANDER/DIRECTOR  
ATMOSPHERIC SCIENCES LABORATORY  
USA ERADCOM  
WHITE SANDS MISSILE RANGE, NM 88002  
ATTN DELAS-AS (HOLT)

OFFICE OF NAVAL RESEARCH  
DEPARTMENT OF THE NAVY  
ARLINGTON, VA 22217  
ATTN STANLEY W. DOROFF, CODE 438  
ATTN D. S. SIEGEL, CODE 211

DEPARTMENT OF THE NAVY  
R&D PLANS DIVISION  
ROOM 5D760, PENTAGON  
WASHINGTON, DC 20350  
ATTN BENJ R. PETRIE, JR.  
OP-987P4

COMMANDER  
NAVAL AIR DEVELOPMENT CENTER  
WARMINSTER, PA 18974  
ATTN R. MCGIBONEY, 30424  
ATTN CODE 8134, LOIS GUISE

COMMANDING OFFICER  
NAVAL AIR ENGINEERING CENTER  
LAKEHURST, NY 08733  
ATTN ESSD, CODE 9314, HAROLD OTT

NAVAL AIR SYSTEMS COMMAND  
DEPARTMENT OF THE NAVY  
WASHINGTON, DC 20360  
ATTN CODE AIR-52022A, J. BURNS  
ATTN CODE AIR-52022E, D. HOUCK

COMMANDER  
PACIFIC MISSILE RANGE  
NAVAL MISSILE CENTER  
POINT MUGU, CA 93042  
ATTN CODE 3123, ABE J. GARRETT  
ATTN CODE 1243, A. ANDERSON

COMMANDER  
NAVAL SHIP ENGINEERING CENTER  
PHILADELPHIA DIVISION  
PHILADELPHIA, PA 19112  
ATTN CODE 6772, D. KEYSER

COMMANDER  
NAVAL SURFACE WEAPONS CENTER  
WHITE OAK, MD 20910  
ATTN CODE 413, CLAYTON MCKINDRA  
ATTN DIV 412, C. J. SEWELL

COMMANDER  
NAVAL ORDNANCE STATION  
INDIANHEAD, MD 20640  
ATTN CODE 5123B, J. MORRIS

NAVAL SHIP RES & DEV CENTER  
CODE 1619, MR. K. READER  
BETHESDA, MD 20084

NAVAL SEA SYSTEMS COMMAND  
SEA0331H  
WASHINGTON, DC 20362  
ATTN A. CHAIKIN

COMMANDER  
NAVAL WEAPONS CENTER  
CHINA LAKE, CA 93555  
ATTN CODE 533, LIBRARY DIVISION  
ATTN CODE 3636, C. BURMEISTER

COMMANDER  
AF AERO PROPULSION LABORATORY, AFSC  
WRIGHT-PATTERSON AFB, OH 45433  
ATTN LESTER SMALL 1TBC

COMMANDER  
AIR FORCE AVIONICS LABORATORY  
WRIGHT-PATTERSON AFB, OH 45433  
ATTN RWN-2, RICHARD JACOBS

DISTRIBUTION (Cont'd)

DIRECTOR  
AF OFFICE OF SCIENTIFIC RESEARCH  
1400 WILSON BLVD  
ARLINGTON, VA 22209  
ATTN NE, MR. GEORGE KNAUSENBERGER

COMMANDER  
AIR FORCE FLIGHT DYNAMICS LABORATORY  
WRIGHT-PATTERSON AFB, OH 45433  
ATTN AFFDL/FGL, H. SNOWBALL

COMMANDER  
AF WEAPONS LABORATORY, AFSC  
KIRTLAND AFB, NM 87117  
ATTN SUL, TECHNICAL LIBRARY

COMMANDER  
ARMAMENT DEVELOPMENT AND TEST CENTER  
EGLIN AIR FORCE BASE, FL 32542  
ATTN ADTC (DLOSL), TECH LIBRARY

AIR FORCE FLIGHT TEST CENTER  
6510 ABG/SSD  
EDWARDS AFB, CA 93523  
ATTN TECHNICAL LIBRARY

AF INSTITUTE OF TECHNOLOGY, AU  
WRIGHT-PATTERSON AFB, OH 45433  
ATTN LIBRARY AFIT(LD),  
BLDG 640, AREA B  
ATTN AFIT (ENM), MILTON E. FRANKE  
(3 COPIES)

AEROSPACE MEDICAL DIVISION  
BROOKS AFB, TX 78235  
ATTN AMD/RDN, CPT G. JAMES

DIV. OF REACTOR RES & DEV  
F-309 USERDA  
WASHINGTON, DC 20545  
ATTN FRANK C. LEGLER

OAK RIDGE NATIONAL LABORATORY  
CENTRAL RES LIBRARY, BLDG 4500N, RM 175  
P. O. BOX X  
OAK RIDGE, TN 37830  
ATTN E. HOWARD

DEPT OF HEW  
PUBLIC HEALTH SERVICE  
NATIONAL INSTITUTE OF HEALTH  
BLDG 13, RM 3W-13  
BETHESDA, MD 20014  
ATTN C. J. MCCARTHY

DEPARTMENT OF COMMERCE  
NATIONAL BUREAU OF STANDARDS  
WASHINGTON, DC 20234  
ATTN DR. JAMES SCHOOLEY, CHIEF,  
TEMPERATURE SECTION  
ATTN DR. T. NEGAS, MATERIALS DIVISION

DEPARTMENT OF COMMERCE  
BUREAU OF EAST-WEST TRADE  
OFFICE OF EXPORT ADMINISTRATION  
WASHINGTON, DC 20230  
ATTN WALTER J. RUSNACK

SCIENTIFIC LIBRARY  
US PATENT OFFICE  
WASHINGTON, DC 20231  
ATTN MRS. CURETON

NASA AMES RESEARCH CENTER  
MOFFETT FIELD, CA 94035  
ATTN MS 244-13, DEAN CHISEL

NASA LANGLEY RESEARCH CENTER  
HAMPTON, VA 23665  
ATTN MS 494, H. D. GARNER  
ATTN MS 494, R. R. HELLBAUM  
ATTN MS 185, TECHNICAL LIBRARY

NASA LEWIS RESEARCH CENTER  
21000 BROOKPARK ROAD  
CLEVELAND, OH 44135  
ATTN VERNON D. GEBBEN

NASA SCIENTIFIC & TECH INFO FACILITY  
P. O. BOX 8657  
BALTIMORE/WASHINGTON INTERNATIONAL  
AIRPORT, MD 21240  
ATTN ACQUISITIONS BRANCH

UNIVERSITY OF ALABAMA  
CIVIL & MINERAL ENGINEERING DEPT.  
P. O. BOX 1468  
UNIVERSITY, AL 35486  
ATTN DR. HAROLD R. HENRY

UNIVERSITY OF ARKANSAS  
TECHNOLOGY CAMPUS  
P. O. BOX 3017  
LITTLE ROCK, AR 72203  
ATTN PAUL C. MCLEOD

UNIVERSITY OF ARKANSAS  
MECHANICAL ENGINEERING  
FAYETTEVILLE, AR 72701  
ATTN JACK H. COLE, ASSOC PROF

DISTRIBUTION (Cont'd)

CARNEGIE-MELLON UNIVERSITY  
SCHENLEY PARK  
PITTSBURGH, PA 15213  
ATTN PROF W. T. ROULEAU, MECH ENGR DEPT

CASE WESTERN RESERVE UNIVERSITY  
UNIVERSITY CIRCLE  
CLEVELAND, OH 44106  
ATTN PROF P. A. ORNER  
ATTN PROF B. HORTON

THE CITY COLLEGE OF THE CITY  
UNIVERSITY OF NY  
DEPT OF MECH ENGR  
139th ST. AT CONVENT AVE  
NEW YORK, NY 10031  
ATTN PROF L. JIJI  
ATTN PROF G. LOWEN

CLEVELAND STATE UNIVERSITY  
FENN COLLEGE OF ENGINEERING  
CLEVELAND, OH 44115  
ATTN PROF R. COMPARIN

DUKE UNIVERSITY  
COLLEGE OF ENGINEERING  
DURHAM, NC 27706  
ATTN C. M. HARMAN

ENGINEERING SOCIETIES LIBRARY  
345 EAST 47TH STREET  
NEW YORK, NY 10017  
ATTN HOWARD GORDON  
ATTN ACQUISITIONS DEPARTMENT

FRANKLIN INSTITUTE OF THE STATE  
OF PENNSYLVANIA  
20TH STREET & PARKWAY  
PHILADELPHIA, PA 19103  
ATTN KA-CHEUNG TSUI, ELEC ENGR DIV  
ATTN C. A. BELSTERLING

HUGHES HELICOPTERS  
DIVISION OF SUMMA CORPORATION  
CENTINELA & TEALE STREETS  
CULVER CITY, CA 90230  
ATTN LIBRARY 2/T2124

IIT RESEARCH INSTITUTE  
10 WEST 35th STREET  
CHICAGO, IL 60616  
ATTN DR. K. E. MCKEE

JOHNS HOPKINS UNIVERSITY  
APPLIED PHYSICS LABORATORIES  
LAUREL, MD 20810  
ATTN MR. MAYNARD HILL  
ATTN MR. THOMAS RANKIN  
ATTN MR. JOSEPH WALL

LEHIGH UNIVERSITY  
DEPARTMENT OF MECHANICAL ENGINEERING  
BETHLEHEM, PA 18015  
ATTN PROF FORBES T. BROWN

LINDA HALL LIBRARY  
5109 CHERRY STREET  
KANSAS CITY, MO 64110  
ATTN DOCUMENTS DIVISION

MASSACHUSETTS INSTITUTE OF TECHNOLOGY  
77 MASSACHUSETTS AVENUE  
CAMBRIDGE, MA 02139  
ATTN ENGINEERING TECHNICAL REPORTS,  
RM 10-408  
ATTN DAVID WORMLEY, MECH ENGR DEPT,  
RM 3-146

MICHIGAN TECHNOLOGICAL UNIVERSITY  
LIBRARY, DOCUMENTS DIVISION  
HOUGHTON, MI 49931  
ATTN J. HAWTHORNE

UNIVERSITY OF MISSISSIPPI  
201 CARRIER HALL, DEPT OF MECH ENGR  
UNIVERSITY, MS 38677  
ATTN DR. JOHN A. FOX

MISSISSIPPI STATE UNIVERSITY  
DRAWER ME  
STATE COLLEGE, MS 39672  
ATTN DR. C. J. BELL, MECH ENG DEPT

UNIVERSITY OF NEBRASKA LIBRARIES  
ACQUISITIONS DEPT, SERIALS SECTION  
LINCOLN, NE 68508  
ATTN ALAN GOULD

UNIVERSITY OF NEW HAMPSHIRE  
MECH ENGR DEPT, KINGSBURY HALL  
DURHAM, NH 03824  
ATTN PROF CHARLES TAFT (3 COPIES)

DEPARTMENT OF MECHANICAL ENGINEERING  
NEWARK COLLEGE OF ENGINEERING  
323 HIGH STREET  
NEWARK, NJ 07102  
ATTN DR. R. Y. CHEN

OHIO STATE UNIVERSITY LIBRARIES  
SERIAL DIVISION, MAIN LIBRARY  
1858 NEIL AVENUE  
COLUMBUS, OH 43210

OKLAHOMA STATE UNIVERSITY  
SCHOOL OF MECH & AEROSPACE ENGR.  
STILLWATER, OK 74074  
ATTN PROF KARL N. REID

DISTRIBUTION (Cont'd)

MIAMI UNIVERSITY  
DEPT OF ENG TECH  
SCHOOL OF APPLIED SCIENCE  
OXFORD, OH 45056  
ATTN PROF S. B. FRIEDMAN

PENNSYLVANIA STATE UNIVERSITY  
215 MECHANICAL ENGINEERING BUILDING  
UNIVERSITY PARK, PA 16802  
ATTN DR. J. L. SHEARER

PENNSYLVANIA STATE UNIVERSITY  
ENGINEERING LIBRARY  
201 HAMMOND BLDG  
UNIVERSITY PARK, PA 16802  
ATTN M. BENNETT, ENGINEERING LIBRARIAN

PURDUE UNIVERSITY  
SCHOOL OF MECHANICAL ENGINEERING  
LAFAYETTE, IN 47907  
ATTN PROF. VICTOR W. GOLDSCHMIDT  
ATTN PROF. ALAN T. MCDONALD

ROCK VALLEY COLLEGE  
3301 NORTH MULFORD ROAD  
ROCKFORD, IL 61101  
ATTN KEN BARTON

RUTGERS UNIVERSITY  
LIBRARY OF SCIENCE & MEDICINE  
NEW BRUNSWICK, NJ 08903  
ATTN GOVERNMENT DOCUMENTS DEPT  
MS. SANDRA R. LIVINGSTON

SYRACUSE UNIVERSITY  
DEPT OF MECH & AEROSPACE ENGINEERING  
139 E. A. LINK HALL  
SYRACUSE, NY 13210  
ATTN PROFESSOR D. S. DOSANJH

UNIVERSITY OF TENNESSEE  
DEPT OF MECHANICAL ENGINEERING  
KNOXVILLE, TN 37916  
ATTN PROF G. V. SMITH

UNIVERSITY OF TEXAS AT AUSTIN  
DEPT OF MECHANICAL ENGINEERING  
AUSTIN, TX 78712  
ATTN DR. A. J. HEALEY

THE UNIVERSITY OF TEXAS AT ARLINGTON  
MECHANICAL ENGINEERING DEPARTMENT  
ARLINGTON, TX 76019  
ATTN DR. ROBERT L. WOODS

TULANE UNIVERSITY  
DEPT OF MECHANICAL ENGINEERING  
NEW ORLEANS, LA 70118  
ATTN H. F. HRUBECKY

UNION COLLEGE  
MECHANICAL ENGINEERING  
SCHENECTADY, NY 12308  
ATTN ASSOC PROF W. C. AUBREY  
MECH ENGR DEPT, STEINMETZ HALL

VIRGINIA POLYTECHNIC INSTITUTE OF STATE UNIV  
MECHANICAL ENGINEERING DEPARTMENT  
BLACKSBURG, VA 24061  
ATTN PROF H. MOSES

WASHINGTON UNIVERSITY  
SCHOOL OF ENGINEERING  
P. O. BOX 1185  
ST. LOUIS, MO 63130  
ATTN W. M. SWANSON

WEST VIRGINIA UNIVERSITY  
MECHANICAL ENGINEERING DEPARTMENT  
MORGANTOWN, WV 26505  
ATTN DR. RICHARD A. BAJURA

WICHITA STATE UNIVERSITY  
WICHITA, KS 67208  
ATTN DEPT AERO ENGR, E. J. RODGERS

UNIVERSITY OF WISCONSIN  
MECHANICAL ENGINEERING DEPARTMENT  
1513 UNIVERSITY AVENUE  
MADISON, WI 53706  
ATTN FEDERAL REPORTS CENTER  
ATTN NORMAN H. BEACHLEY, DIR,  
DESIGN ENGINEERING LABORATORIES

WORCESTER POLYTECHNIC INSTITUTE  
WORCESTER, MA 01609  
ATTN GEORGE C. GORDON LIBRARY (TR)  
ATTN TECHNICAL REPORTS

AIRESEARCH  
P. O. BOX 5217  
402 SOUTH 36th STREET  
PHOENIX, AZ 85034  
ATTN DAVID SCHAFFER  
ATTN TREVOR SUTTON  
ATTN TOM TIPPETTS

AVCO SYSTEMS DIVISION  
201 LOWELL STREET  
WILMINGTON, MA 01887  
ATTN W. K. CLARK  
ATTN R. LIMPAECHER (2 COPIES)

BELL HELICOPTER COMPANY  
P. O. BOX 482  
FORTWORTH, TX 76101  
ATTN MR. R. D. YEARY

DISTRIBUTION (Cont'd)

BENDIX CORPORATION  
ELECTRODYNAMICS DIVISION  
11600 SHERMAN WAY  
N. HOLLYWOOD, CA 90605  
ATTN MR. D. COOPER

BENDIX CORPORATION  
RESEARCH LABORATORIES DIV.  
BENDIX CENTER  
SOUTHFIELD, MI 48075  
ATTN C. J. AHERN

BOEING COMPANY, THE  
P. O. BOX 3707  
SEATTLE, WA 98124  
ATTN HENRIK STRAUB

BOWLES FLUIDICS CORPORATION  
9347 FRASER AVENUE  
SILVER SPRING, MD 20910  
ATTN VICE PRES./ENGR.

DR. RONALD BOWLES  
2105 SONDRRA COURT  
SILVER SPRING, MD 20904

CHAMBERLAIN MANUFACTURING CORP  
EAST 4TH ESTHER STS  
WATERLOO, IA 50705  
ATTN W. WESTERMAN

CONTINENTAL CAN COMPANY  
TECH CENTER  
1350 W. 76TH STREET  
CHICAGO, IL 60620  
ATTN P. A. BAUER

CORDIS CORPORATION  
P. O. BOX 428  
MIAMI, FL 33137  
ATTN STEPHEN F. VADAS, K-2

CORNING GLASS WORKS  
FLUIDIC PRODUCTS  
HOUGHTON PARK, B-2  
CORNING, NY 14830  
ATTN R. H. BELLMAN

CHRYSLER CORPORATION  
P.O. BOX 118  
CIMS-418-33-22  
DETROIT, MI 48231  
ATTN MR. L. GAU

JOHN DEERE PRODUCT ENGINEERING CENTER  
WATERLOO, IA 50704  
ATTN V. S. KUMAR

EMX ENGINEERING, INC  
BOX 216 - 216 LITTLE FALLS RD  
CEDAR GROVE, NJ 07009  
ATTN ANTHONY P. CORRADO, PRESIDENT

FLUIDICS QUARTERLY  
P. O. BOX 2989  
STANFORD, CA 94305  
ATTN D. H. TARUMOTO

GENERAL ELECTRIC COMPANY  
SPACE/RES D DIVISIONS  
P. O. BOX 8555  
PHILADELPHIA, PA 19101  
ATTN MGR LIBRARIES, LARRY CHASEN

GENERAL MOTORS CORPORATION  
DELCO ELECTRONICS DIV  
MANFRED G. WRIGHT  
NEW COMMERCIAL PRODUCTS  
P. O. BOX 1104  
KOKOMO, IN 46901  
ATTN R. E. SPARKS

GRUMMAN AEROSPACE CORPORATION  
TECHNICAL INFORMATION CENTER  
SOUTH OYSTER BAY ROAD  
BETHPAGE, L. I., NY 11714  
ATTN C. W. TURNER, DOCUMENTS  
LIBRARIAN

HAMILTON STANDARD  
DIVISION OF UNITED AIRCRAFT CORPORATION  
WINDSOR LOCKS, CT 06096  
ATTN MR. PHILIP BARNES

HONEYWELL, INC.  
1625 ZARTHAN AVE  
MINNEAPOLIS, MI 55413  
ATTN J. HEDEEN

JOHNSON CONTROLS, INC  
507 E. MICHIGAN  
MILWAUKEE, WI 53201  
ATTN WARREN A. LEDERMAN

MOORE PRODUCTS COMPANY  
SPRING HOUSE, PA 19477  
ATTN MR. R. ADAMS

MARTIN MARIETTA CORPORATION  
AEROSPACE DIVISION  
P. O. BOX 5837  
ORLANDO, FL 32805  
ATTN R. K. BRODERSON, MP 326  
ATTN VITO O. BRAVO, MP 326

DISTRIBUTION (Cont'd)

MCDONNELL AIRCRAFT COMPANY  
GUIDANCE AND CONTROL MECHANICS DIVISION  
ST. LOUIS, MO 63166  
ATTN MR. LOYAL GUENTHER

NATIONAL FLUID POWER ASSOCIATION  
3333 NORTH MAYFAIR ROAD  
MILWAUKEE, WI 53222  
ATTN JOHN R. LUEKE  
DIR OF TECH SERVICES

PLESSEY AEROSPACE LTD  
1700 OLD MEADOW ROAD  
MCLEAN, VA 22102  
ATTN A. ROSENBERG

RICHARD WHITE & ASSOCIATES  
ELECTRO/MECHANICAL ENGINEERS  
77 PELHAM ISLE ROAD  
SUDBURY, MA 01776  
ATTN RICHARD P. WHITE

ROCKWELL INTERNATIONAL CORPORATION  
COLUMBUS AIRCRAFT DIVISION,  
P. O. BOX 1259  
4300 E. 5TH AVENUE  
COLUMBUS, OH 43216  
ATTN MR. MARVIN SCHWEIGER

SANDIA CORPORATION  
KIRTLAND AFB, EAST  
ALBUQUERQUE, NM 87115  
ATTN WILLIAM R. LEUENBERGER, DIV 2323

STEIN ENGINEERING SERVICES, INC  
5602 E. MONTEROSA  
PHOENIX, AZ 85018

TRITEC, INC  
P.O. BOX 56  
COLUMBIA, MD 21045  
ATTN L. SIERACKI

UNITED TECHNOLOGIES RESEARCH CENTER  
400 MAIN STREET  
E. HARTFORD, CT 06108  
ATTN R. E. OLSON, MGR FLUID  
DYNAMICS LABORATORY

US ARMY ELECTRONICS RESEARCH  
& DEVELOPMENT COMMAND  
ATTN TECHNICAL DIRECTOR, DRDEL-CT

HARRY DIAMOND LABORATORIES  
ATTN 00100, COMMANDER/TECH DIR/TSO  
ATTN CHIEF, DIV 10000  
ATTN CHIEF, DIV 20000  
ATTN CHIEF, DIV 30000  
ATTN CHIEF, DIV 40000  
ATTN RECORD COPY, 81200  
ATTN HDL LIBRARY, (3 COPIES) 81100  
ATTN HDL LIBRARY, (WOODBIDGE) 81100  
ATTN TECHNICAL REPORTS BRANCH, 81300  
ATTN CHAIRMAN, EDITORIAL COMMITTEE  
ATTN CORRIGAN, J., 00240  
ATTN CHIEF, 13000  
ATTN CHIEF, 13400 (10 COPIES)  
ATTN DRZEWIECKI, T., 13400 (10 COPIES)  
ATTN COX, L. S., 00210  
ATTN LANHAM, C., 00210  
ATTN MON, G., 13400  
ATTN DEADWYLER, R., 13400  
ATTN GOTO, J., 13400  
ATTN TENNEY, S., 13400  
ATTN TODA, K., 13400  
ATTN JOYCE, J., 13400  
ATTN PHILLIPI, R. M., 13400 (10 COPIES)