

AD-A084 359 MASSACHUSETTS INST OF TECH CAMBRIDGE DEPT OF OCEAN E--ETC F/6 20/4  
ON THE THEORY OF FLOW OF REGULAR WATER WAVES ABOUT A BODY.(U)  
MAR 80 F NOBLESSE N00014-78-C-0169  
UNCLASSIFIED 80-2 NL

1 OF 1  
AD-A084359

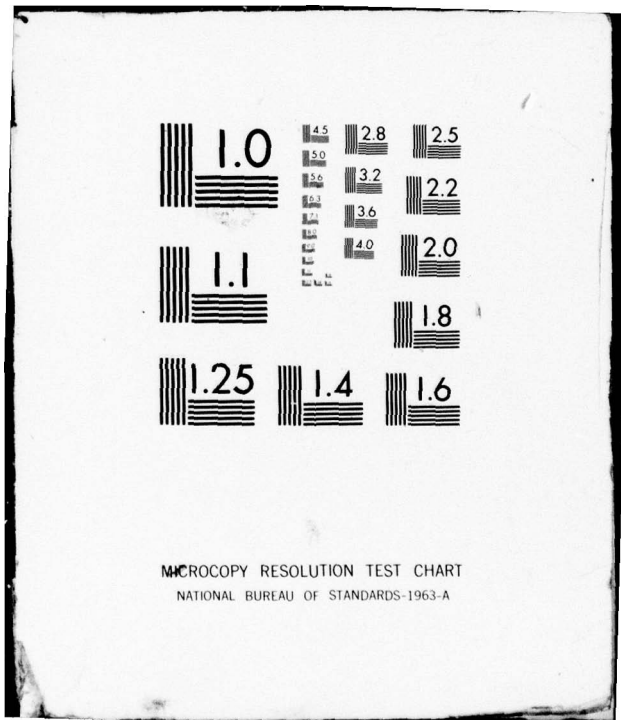

END  
DATE  
FILMED  
6-80  
DTIC



MICROCOPY RESOLUTION TEST CHART  
NATIONAL BUREAU OF STANDARDS-1963-A

# LEVEL II

①

MASSACHUSETTS INSTITUTE OF TECHNOLOGY  
Department of Ocean Engineering  
Cambridge, MA 02139

Report No. 80-2

ON THE THEORY OF FLOW OF REGULAR  
WATER WAVES ABOUT A BODY

by

Francis Noblesse

March 1980

Accession For	
NTIS GRA&I	<input checked="" type="checkbox"/>
DDC TAB	<input type="checkbox"/>
Unannounced	<input type="checkbox"/>
Justification	
By _____	
Distribution/	
Availability Codes	
Dist.	Avail and/or special
A	

DTIC  
ELECTE  
MAY 12 1980  
S D  
D

This work was supported by the Office of Naval Research,  
Contract N00014-78-C-0169, NR 062-525, MIT OSP 85949

Approved for public release; distribution unlimited.

80 5 7 002

UNCLASSIFIED

SECURITY CLASSIFICATION OF THIS PAGE (When Data Entered)

14 REPORT DOCUMENTATION PAGE		READ INSTRUCTIONS BEFORE COMPLETING FORM	
1. REPORT NUMBER 80-2	2. GOVT ACCESSION NO. DA084359	3. RECIPIENT'S CATALOG NUMBER	
4. TITLE (and Subtitle) ON THE THEORY OF FLOW OF REGULAR WATER WAVES ABOUT A BODY.		5. TYPE OF REPORT & PERIOD COVERED 9) Technical Report	
7. AUTHOR(s) Francis Noblesse		8. CONTRACT OR GRANT NUMBER(s) N00014-78-C-0169 NR-062-525	
9. PERFORMING ORGANIZATION NAME AND ADDRESS Department of Ocean Engineering Massachusetts Institute of Technology Cambridge, MA 02139		10. PROGRAM ELEMENT, PROJECT, TASK AREA & WORK UNIT NUMBERS	
11. CONTROLLING OFFICE NAME AND ADDRESS Office of Naval Research		12. REPORT DATE Mar 80	
14. MONITORING AGENCY NAME & ADDRESS (if different from Controlling Office)		13. NUMBER OF PAGES 62	
16. DISTRIBUTION STATEMENT (of this Report) Distribution of this document is unlimited		18. SECURITY CLASS. (of this report) Unclassified	
17. DISTRIBUTION STATEMENT (of the abstract entered in Block 20, if different from Report)		19a. DECLASSIFICATION/DOWNGRADING SCHEDULE	
18. SUPPLEMENTARY NOTES			
19. KEY WORDS (Continue on reverse side if necessary and identify by block number) regular water waves wave diffraction wave radiation integral equation Green function			
20. ABSTRACT (Continue on reverse side if necessary and identify by block number) → The object of this study is to present new results concerning the integral-equation-Green-function method of solution of the basic linearized problem of potential flow of regular water waves about a body. The main results of the study are: (i) a new integral equation for determining the velocity potential, (ii) a relatively simple explicit approximate solution of this integral equation, and (iii) asymptotic expansions, ascending series, and one-dimensional Taylor series expansions for efficient numerical evaluation of the Green function. ←			

DD FORM 1 JAN 73 1473 EDITION OF 1 NOV 65 IS OBSOLETE S/N 0102-014-6601

UNCLASSIFIED SECURITY CLASSIFICATION OF THIS PAGE (When Data Entered)

406856

Jm

ON THE THEORY OF FLOW OF REGULAR WATER WAVES ABOUT A BODY

TABLE OF CONTENTS

	<u>Page</u>
Abstract, Acknowledgments.....	i
Introduction.....	1
1. The basic potential-flow problem.....	5
2. The Green function.....	9
3. Basic integral identities.....	17
4. Applications and discussion.....	26
5. The Green function: single-integral representations.....	34
5.1. Haskind's representation.....	35
5.2. The near-field representation.....	39
5.3. The far-field representation.....	40
6. The Green function: asymptotic expansions.....	44
7. The Green function: ascending series.....	50
8. The Green function: one-dimensional Taylor series expansions.....	56
9. The gradient of the Green function.....	60
References.....	62

## ABSTRACT

The object of this study is to present new results concerning the integral-equation-Green-function method of solution of the basic linearized problem of potential flow of regular water waves about a body. Specifically, this basic potential-flow problem consists in determining the velocity potential given by the solution of the Laplace equation subject to the usual linearized boundary condition on the mean free surface and to a Neumann condition on the mean body surface. The main results of the study are: (i) a new integral equation for determining the velocity potential, (ii) a relatively simple explicit approximate solution of this integral equation, and (iii) asymptotic expansions, ascending series, and one-dimensional Taylor series expansions for efficient numerical evaluation of the Green function.

## ACKNOWLEDGMENTS

I want to thank Mr. Cheng-Yo Chen for reviewing the manuscript.

### Introduction

The object of this study is to present new results concerning the integral-equation-Green-function method of solution of the basic linearized problem of potential flow of regular (time-harmonic) water waves about a body. Particular problems of practical interest encompassed in this basic potential-flow problem are the usual problems of wave diffraction, in which the body is held fixed, and of wave radiation, in which the body is forced to oscillate about a mean position in otherwise calm water; the problem of linearized motion of a freely-floating body in regular waves can be decomposed into such a wave-diffraction and six fundamental wave-radiation problems (corresponding to the six possible degrees of freedom of motion of an unrestrained rigid body), as is well known. However, this study is not concerned with these important particular problems per se, but with the development of a general method of solution of the basic potential-flow problem common to these practical problems. Specifically, this basic potential-flow problem consists in determining the velocity potential ( $\phi$ ) given by the solution of the Laplace equation subject to the usual linearized boundary condition on the mean free surface and to a Neumann condition (specified normal derivative  $\phi_n$ ) on the mean body surface.

The main results obtained in this study are a new integral equation for determining the velocity potential, and asymptotic expansions, ascending series, and one-dimensional Taylor series expansions for fast and easy numerical evaluation of the Green function (i.e. the velocity potential of the flow caused by a source of pulsating strength at a fixed position in otherwise calm water); furthermore, a relatively simple explicit approximation for the velocity potential is given, although the practical usefulness of this explicit approximate solution remains to be tested numerically. The plan and content of the study are briefly described below.

The basic potential-flow problem is formulated in section 1. In section 2, the Green function associated with the linearized free-surface boundary condition is defined, and the classical expression — in terms of a double integral — for this fundamental function is briefly derived. The main result of section 2 is stated by equations (2.13) and (2.14). Equations (2.13) are well known; these equations, however, are valid only for  $\zeta$  strictly negative, and equations (2.14) are proper in the limiting case  $\zeta = 0$ .

This distinction is important in section 3, where fundamental integral identities verified by the velocity potential are obtained by using equations (2.13) and (2.14) in the classical Green identity (3.1). Identities (3.6a,b,c) are well known [although the particular case of these equations corresponding to  $\nabla^2 \phi = 0 = \phi_z - f(1+i\epsilon)^2 \phi$  is usually given in the literature, and the traditional derivation of these identities from the Green identity (3.1) is somewhat different from that shown in this study]. The main result of section 3, however, is the integral identity (3.9). This new integral identity is valid outside, inside, and on the body, and thus is equivalent to the set of the three classical identities (3.6a,b,c). An interesting alternative form of the integral identity (3.9) is given by equation (3.10), which involves a "modified Green function". Although the present study is primarily concerned with the "exterior potential-flow problem", that is the problem of flow about a body, the integral identities corresponding to identities (3.6), (3.9) and (3.10) are also given for the "interior potential-flow problem". It is interesting that whereas the classical identities (3.6a,b,c) and (3.11a,b,c) for the exterior and interior problems, respectively, are identical (provided only one properly interchanges the terms "exterior" and "interior"), identities (3.9) and (3.12), or the equivalent alternative identities (3.10) and (3.13), are not identical. In particular identities (3.10) and (3.13), although identical in form, involve the different "modified Green functions"  $\tilde{G}$  and  $G^i$  defined by equations (3.10a) and (3.13a) for the "exterior" and "interior" problems, respectively. The zero- and infinite-frequency limits finally are briefly considered.

Section 4 is mainly concerned with the usual linearized problem of flow of regular waves about a body. In this important special case, the general integral identity (3.9) becomes equation (4.2), which provides an integral equation for determining the potential  $\phi$  on the body surface. This new integral equation is one of the major results of the present study, and it is discussed in some detail. In particular, a notable feature distinguishing the integral equation (4.2) from the classical integral equation (3.1) and analogous integral equations is that every term in equation (4.2) is continuous at the body surface. Another interesting feature of the integral equation (4.2) is the presence of the "waterplane integral" defined by formula (3.9a) in the case of a free-surface piercing body. (This waterplane integral is not present in the case of a fully-submerged body). A simple explanation for

the occurrence of the "waterplane integral" is provided by considering a free-surface piercing body as the "zero-submergence limit" of a slightly-submerged body consisting of the mean wetted surface of the body closed by a horizontal "lid". A relatively simple explicit approximation for the velocity potential  $\phi$ , defined by formulas (4.8) and (4.3), is finally given; this explicit approximate solution is one of the main results of the present study.

A major difficulty in the numerical solution of the integral equation (4.2) or in the evaluation of the approximation (4.8) stems from the fact that calculation of the basic double-integral representation of the Green function given by expression (2.10b), or by the alternative expression (2.10a), requires excessive computing time. The object of the remaining five sections of the study thus is to obtain simplified expressions for the Green function that can easily and efficiently be evaluated numerically. In a first step, three alternative and complementary single-integral representations of the Green function, that is expressions involving single (one-fold) integrals only, are obtained from the two above-mentioned double-integral representations. These three single-integral representations, given in section 5, are: (i) the "Haskind integral representation" (5.8c), which is essentially identical to an expression obtained (in a different manner) by Haskind [1], (ii) the "near-field integral representation" (5.11), which was also obtained (independently and in a different manner) by Martin [2], and (iii) the far-field integral representation" (5.21), which does not appear to have been given previously. The "near-field representation" (5.11) and the "far-field representation" (5.21) are analogous to the single-integral representations of the Green function of ship-wave-resistance theory given in [3].

In a second step, asymptotic expansions, ascending series, and one-dimensional Taylor series expansions are obtained from the three above-mentioned alternative single-integral representations of the Green function. Specifically, two complementary asymptotic expansions (useful for evaluating the Green function sufficiently far away from the singularity) are derived, in section 6, from the near-field and the far-field integral representations (5.11) and (5.21). These asymptotic expansions are given by equations (6.8) and (6.14). Comparison of these complementary expansions then yields the single asymptotic expansion (6.17). In section 7, an ascending series (useful for evaluating the Green function in the vicinity of the singularity) is derived from the

near-field integral representation (5.11). This ascending series is given by equations (7.7), (7.8), and (7.22). In section 8, one-dimensional Taylor series expansions are obtained from the near-field and the Haskind integral representations (5.11) and (5.8c). These series are given by equations (8.8) and (8.13). Finally, expressions for the gradient of the Green function are given in section 9. In particular, the vertical derivative,  $G_z$ , of the Green function  $G$  can be directly expressed in terms of  $G$ , as shown in expression (9.5), which was previously given by Martin [2], and is obtained here in a different manner (by following an idea used by Eggers [4] for the analogous problem of ship wave resistance).

### 1. The basic potential-flow problem

The basic potential-flow problem of the linearized theory of flow about a body in regular water waves investigated in the present study is briefly formulated in this section. A sea of infinite depth and lateral extent is assumed, and water is regarded as homogeneous and incompressible (with density  $\rho$ ) as well as inviscid. The only body force considered is that due to a uniform gravitational field (with acceleration  $g$ ). Surface tension and free-surface nonlinearities are neglected. The flow is irrotational and thus can be represented by a velocity potential  $\phi'$ , which is a function of the Cartesian coordinates  $\vec{X}(X,Y,Z)$  and of the time  $T$ , i.e.  $\phi'(\vec{X},T)$ . The mean (undisturbed) free surface of the sea is taken as the plane  $Z = 0$ , with the  $Z$  axis positive upwards.

The linearized dynamic free-surface boundary condition takes the well-known form

$$gE' + \phi'_T + P'/\rho = 0 \quad \text{on } Z = 0,$$

where  $E'(X,Y,T)$  is the elevation of the free surface above, or below, its mean level  $Z = 0$ ,  $\phi'_T \equiv \partial\phi'(X,Y,Z=0,T)/\partial T$ , and  $P'(X,Y,T)$  is the difference between the pressure at the free surface and the atmospheric pressure. For most problems of practical interest, the pressure at the free surface is constant equal to the atmospheric pressure, so that one then has  $P' = 0$ . In the presence of a fluid flux,  $Q'(X,Y,T)$  say, across the free surface, the linearized kinematic free-surface boundary condition takes the form

$$\phi'_Z = E'_T - Q' \quad \text{on } Z = 0,$$

where  $Q' < 0$  clearly corresponds to fluid being sucked away across the free surface. While for all practical problems we have  $Q' = 0$ , it will be important to allow a fluid flux across the free surface for determining the free-surface condition verified by the Green function, as will be shown in the next section. Elimination of the free-surface elevation  $E'$  between the foregoing dynamic and kinematic free-surface conditions then yields the free-surface boundary condition

$$g\phi'_Z + \phi'_{TT} = -P'_T/\rho - gQ' \quad \text{on } Z = 0, \quad (1.1)$$

which thus involves the velocity potential  $\phi'$  alone.

In the present study, we are interested in flows that are simple harmonic in time, say with radiant frequency  $\omega$  (period  $2\pi/\omega$ ). As it is well known, and is discussed for instance in Stoker [5], such free-surface gravity flows are not completely (uniquely) determined unless one imposes a "radiation condition" expressing that waves at a sufficient distance away from the disturbance (e.g. a body in the present problem) which created them must be like "outgoing" progressing waves, i.e. like progressing waves moving away from the wave's source. A convenient alternative approach, employed for instance in Lighthill [6], to the use of such a "radiation condition" of "outgoing waves", consists in defining a time-harmonic flow as the limit- as the small positive auxiliary parameter  $\epsilon$  vanishes- of a flow defined by a velocity potential of the form

$$\phi'(\vec{X}, T) = \text{Re}\phi(\vec{X}) \exp[-i\omega(1+i\epsilon)T] \quad , \quad (1.2a)$$

where  $\text{Re}$  represents the real part. The free-surface pressure and flux are similarly assumed to be of the form

$$P'(X, Y, T) = \text{Re}P(X, Y) \exp[-i\omega(1+i\epsilon)T] \quad , \quad (1.2b)$$

$$Q'(X, Y, T) = \text{Re}Q(X, Y) \exp[-i\omega(1+i\epsilon)T] \quad . \quad (1.2c)$$

In this alternative approach, one then is faced with a traditional "initial-value problem", with the obvious initial conditions  $\phi' = 0$  and  $\phi'_T = 0$  for  $T = -\infty$ . Use of expressions (1.2a,b,c) into equation (1.1) then yields the following free-surface boundary condition:

$$g\phi'_Z - \omega^2(1+i\epsilon)^2\phi = i\omega(1+i\epsilon)P/\rho - gQ \quad \text{on } Z = 0, \quad (1.3)$$

for the "spatial component"  $\phi(\vec{X})$  of the actual potential  $\phi'(\vec{X}, T)$ .

It will be convenient to define adimensional variables in terms of  $1/\omega$  as reference time and of some reference length  $L$ , from which the reference velocity  $\omega L$ , potential  $\omega L^2$ , and pressure  $\rho\omega^2 L^2$  can be readily formed.

We thus define the adimensional variables

$$t = \omega T, \quad \vec{x} = \vec{X}/L, \quad \phi = \phi/\omega L^2, \quad p = P/\rho\omega^2 L^2, \quad q = Q/\omega L. \quad (1.4)$$

In terms of these adimensional variables, the free-surface condition (1.3) can be shown to become

$$\phi_z - f(1+i\epsilon)^2 \phi = if(1+i\epsilon)p - q \quad \text{on } z = 0, \quad (1.5)$$

where  $f$  is the "frequency parameter" defined as

$$f = \omega^2 L/g. \quad (1.5a)$$

The "frequency parameter"  $f$  can obviously be made equal to unity by selecting the reference length  $L$  as  $g/\omega^2$ . This choice of reference length essentially corresponds to taking the length of the water waves as reference length since we have  $g/\omega^2 = \lambda/2\pi$  - with  $\lambda$  the wave length of plane progressive waves of frequency  $\omega$  - from the "dispersion relation" for water waves in deep water. In this choice of reference length, the size of the body causing the waves would however appear to vary with the frequency  $\omega$  (the body becoming small at low frequency and large at high frequency). An alternative (possibly more convenient for practical purposes) choice is to take the reference length  $L$  as a length characterizing the size of the body, which would thus remain the same at all frequencies. The length of the waves, however, would then vary with the frequency (the waves being long at low frequency and short at high frequency).

The basic potential-flow problem of the linearized theory of flow about a body in regular water waves can now be briefly stated. As it is well known, this problem consists of solving the Laplace equation

$$\nabla^2 \phi = 0 \quad \text{in } (d), \quad (1.6a)$$

subject to the boundary conditions specified below. The solution domain  $(d)$  in equation (1.6a) is the domain exterior to the body and bounded upwards by the mean free surface  $(\sigma)$  say, which consists in the whole plane

$z = 0$  if the body is fully submerged or in the portion of the plane  $z = 0$  exterior to the body in the case the body pierces the free surface. On the mean free surface ( $\sigma$ ), the free-surface boundary condition (1.5) must be verified:

$$\phi_z - f(1+i\epsilon)^2 \phi = if(1+i\epsilon)p - q \text{ on } (\sigma), \quad (1.6b)$$

where in fact we generally have  $p = 0 = q$  for the problem of flow about a body. The potential  $\phi$  must vanish at infinity; specifically, we have the condition

$$\phi = O(1/|\vec{x}|) \text{ as } |\vec{x}| \rightarrow \infty, \quad (1.6c)$$

expressing that  $\phi$  vanishes at least as fast as  $1/|\vec{x}|$  as  $|\vec{x}| \rightarrow \infty$ . Finally, on the body surface, (b) say, which actually consists only in the portion of the body surface located below the plane  $z = 0$  if the body pierces the free surface, the potential  $\phi$  must verify the usual "body boundary condition"

$$\phi_n \text{ given on } (b), \quad (1.6d)$$

where  $\phi_n \equiv \partial\phi/\partial n \equiv \nabla\phi \cdot \vec{n}$  is the derivative of  $\phi$  in the direction of the unit normal  $\vec{n}$  to (b), which is taken to be pointing outwards with respect to the fluid, i.e. inside the body. The precise form taken by the expression for  $\phi_n$  on (b) in particular problems, notably in the usual "radiation" and "diffraction" problems, may be found in various places in the literature, e.g. in Newman [7]. In the zero-frequency limit ( $f=0$ ) the free-surface boundary condition (1.6b) becomes

$$\phi_z = -q \text{ on } (\sigma), \quad (1.7a)$$

whereas in the infinite-frequency limit ( $f=\infty$ ) it becomes

$$\phi = -ip/(1+i\epsilon) \text{ on } (\sigma). \quad (1.7b)$$

## 2. The Green function

A well-known technique for solving a potential-flow problem such as the one defined above by equations (1.6 a,b,c,d), in the general case of an arbitrarily-shaped body, consists in formulating an integral equation for the potential  $\phi$  based on the use of a Green function verifying all the boundary conditions of the problem except the "body condition", which is to be verified by means of the integral equation. The Green function,  $G(\vec{x}; \vec{\xi}, f, \epsilon)$  say, appropriate to the present problem then is the solution of the problem defined by the following equations:

$$\nabla^2 G = \delta(x-\xi) \delta(y-\eta) \delta(z-\zeta) \quad \text{in } z < 0 \quad (2.1a)$$

$$G_z - f(1+i\epsilon)^2 G = 0 \quad \text{on } z = 0, \quad (2.1b)$$

$$G = O(1/r) \quad \text{as } r \rightarrow \infty, \quad (2.1c)$$

where  $\delta(\ )$  is the usual "Dirac delta function", and  $r \equiv |\vec{x} - \vec{\xi}|$  is the distance between the "field point"  $\vec{x}$  and the singularity"  $\vec{\xi}$ .

A particular solution of the Poisson equation (2.1a) is given by  $4\pi G = -1/r$ , as is well known and can readily be verified. The general solution of equation (2.1a) can thus be written as

$$4\pi G(\vec{x}; \vec{\xi}, f, \epsilon) = -1/r + H(\vec{x}; \vec{\xi}, f, \epsilon), \quad (2.2)$$

where the function  $H$  is regular harmonic in the lower half space  $z < 0$ , and evidently is to be determined from the boundary conditions (2.1b,c). Indeed, use of expression (2.2) into equations (2.1a,b,c) yields

$$\nabla^2 H = 0 \quad \text{in } z < 0, \quad (2.3a)$$

$$H_z - f(1+i\epsilon)^2 H = [\partial_z - f(1+i\epsilon)^2](1/r) \quad \text{on } z = 0, \quad (2.3b)$$

$$H = O(1/r) \quad \text{as } r \rightarrow \infty. \quad (2.3c)$$

The above problem can be solved by using a double Fourier transform with respect to the horizontal coordinates  $x$  and  $y$ . The double Fourier transform of the function  $H(\vec{x}; \vec{\xi}, f, \epsilon)$  is denoted by  $H^{**}(\alpha, \beta, z; \vec{\xi}, f, \epsilon)$  and defined as

$$H^{**}(\alpha, \beta, z; \vec{\xi}, f, \epsilon) = \frac{1}{2\pi} \int_{-\infty}^{\infty} dy \int_{-\infty}^{\infty} dx e^{i(\alpha x + \beta y)} H(\vec{x}; \vec{\xi}, f, \epsilon). \quad (2.4)$$

The corresponding Fourier transform of the function  $1/r$  is

$$(1/r)^{**} = (1/k) \exp[-k|z-\zeta| + i(\alpha\xi + \beta\eta)] \quad (2.5)$$

where  $k \equiv (\alpha^2 + \beta^2)^{1/2}$  by definition, as it may be verified. By taking the double Fourier transform with respect to  $x$  and  $y$  of equations (2.3a,b,c), we may then obtain the following "Fourier-transformed problem" for the function  $H^{**}(z; \alpha, \beta, \vec{\xi}, f, \epsilon)$ :

$$d^2 H^{**}/dz^2 - k^2 H^{**} = 0 \quad \text{in } z < 0, \quad (2.6a)$$

$$dH^{**}/dz - f(1+i\epsilon)^2 H^{**} = -[1+f(1+i\epsilon)^2/k] e^{k\zeta + i(\alpha\xi + \beta\eta)} \quad \text{on } z = 0, \quad (2.6b)$$

$$H^{**} \rightarrow 0 \quad \text{as } z \rightarrow -\infty. \quad (2.6c)$$

The general solution of the ordinary differential equation (2.6a) is  $H^{**} = A \exp(kz) + B \exp(-kz)$ , where  $A$  and  $B$  are arbitrary constants. The boundary condition (2.6c) shows that  $B=0$ , and the constant  $A$  then can be determined from the free-surface condition (2.6b). We thus may obtain

$$H^{**} = - \frac{k+f(1+i\epsilon)^2}{k-f(1+i\epsilon)^2} \frac{1}{k} e^{k(z+\zeta) + i(\alpha\xi + \beta\eta)}, \quad (2.7)$$

which can be expressed in the equivalent forms

$$H^{**} = - \frac{1}{k} e^{k(z+\zeta) + i(\alpha\xi + \beta\eta)} - \frac{2f(1+i\epsilon)^2}{k-f(1+i\epsilon)^2} \frac{1}{k} e^{k(z+\zeta) + i(\alpha\xi + \beta\eta)}, \quad (2.7a)$$

$$H^{**} = \frac{1}{k} e^{k(z+\zeta) + i(\alpha\xi + \beta\eta)} - \frac{2}{k-f(1+i\epsilon)^2} e^{k(z+\zeta) + i(\alpha\xi + \beta\eta)}. \quad (2.7b)$$

It may be seen from equation (2.5) that the first term on the right side of equation (2.7b) is equal to the double Fourier transform  $(1/r')^{**}$  of  $1/r'$ , where  $r'$  is defined as  $r' \equiv (x'^2 + y'^2 + z'^2)^{1/2}$  with  $x' \equiv x - \xi$ ,  $y' \equiv y - \eta$ , and  $z' \equiv z + \zeta$ , so that  $\vec{x}'(x', y', z')$  is the vector joining the mirror image of the "singularity"  $\vec{\xi}$  with respect to the free surface  $z = 0$  to the "field point"  $\vec{x}$ , and  $r'$  is the distance between these two points.

The function  $H(\vec{x}; \vec{\xi}, f, \epsilon)$  may now be obtained by taking the inverse double Fourier transform of the function  $H^{**}(\alpha, \beta, z; \vec{\xi}, f, \epsilon)$ , namely

$$H(x, y, z; \vec{\xi}, f, \epsilon) = \frac{1}{2\pi} \int_{-\infty}^{\infty} d\beta \int_{-\infty}^{\infty} d\alpha e^{-i(\alpha x + \beta y)} H^{**}(\alpha, \beta, z; \vec{\xi}, f, \epsilon). \quad (2.8)$$

By using expressions (2.7a,b) for  $H^{**}$  into equation (2.8), and by using the resulting expression for  $H$  into equation (2.2), we can then obtain the following alternative expressions for the Green function  $G(\vec{x}; \vec{\xi}, f, \epsilon)$ :

$$4\pi G = -\frac{1}{r} - \frac{1}{r'} - \frac{f(1+i\epsilon)^2}{\pi} \int_{-\infty}^{\infty} d\beta \int_{-\infty}^{\infty} d\alpha e^{\frac{kz' - i(\alpha x' + \beta y')}{k[k - f(1+i\epsilon)^2]}}, \quad (2.9a)$$

$$4\pi G = -\frac{1}{r} + \frac{1}{r'} - \frac{1}{\pi} \int_{-\infty}^{\infty} d\beta \int_{-\infty}^{\infty} d\alpha e^{\frac{kz' - i(\alpha x' + \beta y')}{k - f(1+i\epsilon)^2}}. \quad (2.9b)$$

The Green function  $G(\vec{x}; \vec{\xi}, f, \epsilon)$  obviously is axisymmetric about the vertical axis  $x = \xi$ ,  $y = \eta$ , so that we may take  $y' \equiv y - \eta$  as zero and replace  $x' \equiv x - \xi$  by  $\rho \equiv (x'^2 + y'^2)^{1/2}$  in expressions (2.9a,b). Expression (2.9b) then becomes

$$4\pi G = -\frac{1}{r} + \frac{1}{r'} - \frac{2}{\pi} \int_0^{\infty} d\beta \int_{-\infty}^{\infty} d\alpha e^{\frac{z'(\alpha^2 + \beta^2)^{1/2} - i\rho\alpha}{(\alpha^2 + \beta^2)^{1/2} - f(1+i\epsilon)^2}}. \quad (2.10a)$$

A more usual alternative expression is that which can be obtained by performing the substitution  $y' = 0$  and  $x' = \rho$  in expression (2.9a), followed by a

transformation from the Cartesian Fourier variables  $\alpha$  and  $\beta$  to the polar variables  $k \equiv (\alpha^2 + \beta^2)^{1/2}$  and  $\theta$ , specifically by performing the change of variable  $\alpha = k \cos \theta$  and  $\beta = k \sin \theta$ . The resulting classical expression is

$$4\pi G = -\frac{1}{r} - \frac{1}{r'} - f(1+i\epsilon)^2 \frac{2}{\pi} \int_0^\pi d\theta \int_0^\infty dk \frac{e^{(z'-i\rho \cos \theta)k}}{k-f(1+i\epsilon)^2} \quad (2.10b)$$

Expressions (2.10a,b) show that  $G(\vec{x}; \vec{\xi}, f, \epsilon)$  actually is a function of only three space variables, namely  $\rho \equiv (x'^2 + y'^2)^{1/2}$ ,  $z' \equiv z + \zeta$ , and  $(z - \zeta)^2$  which occurs in  $r \equiv [\rho^2 + (z - \zeta)^2]^{1/2}$ .

As it is self-evident from equations (2.1a,b,c), the physical significance of the Green function  $G(\vec{x}; \vec{\xi}, f, \epsilon)$  is that  $\text{Re}G(\vec{x}; \vec{\xi}, f, \epsilon) \exp(\epsilon - i)t$  is the linearized velocity potential, at the "field point"  $\vec{x}(x, y, z \leq 0)$  and at the time  $t$ , of the flow caused by a submerged pulsating source of strength  $\text{Re} \exp(\epsilon - i)\tau$ ,  $-\infty \leq \tau \leq t$ , located at point  $\vec{\xi}(\xi, \eta, \zeta < 0)$ . This well-known physical interpretation becomes ambiguous however in the limiting case  $\zeta = 0$ , since the source then is obviously no longer fully submerged. A natural complementary interpretation for this limiting case is to assume that the outflow produced at point  $(\xi, \eta, \zeta = 0)$  now stems from a flux  $\text{Re} q(x, y) \exp(\epsilon - i)t$ , with  $q(x, y) = \delta(x - \xi) \delta(y - \eta)$ , across the mean free surface  $z = 0$ . Equations (1.6a,b,c) then suggest that the "limit Green function"  $G_\ell(\vec{x}; \xi, \eta, f, \epsilon) \equiv G(\vec{x}; \xi, \eta, \zeta = 0, f, \epsilon)$  must verify the following equations

$$\nabla^2 G_\ell = 0 \text{ in } z < 0, \quad (2.11a)$$

$$G_{\ell z} - f(1+i\epsilon)^2 G_\ell = -\delta(x - \xi) \delta(y - \eta) \text{ on } z = 0, \quad (2.11b)$$

$$G_\ell = 0(1/r) \text{ as } r \rightarrow \infty. \quad (2.11c)$$

A mathematical demonstration of the above physically-motivated equations can readily be provided by verifying that the solution  $G_\ell(\vec{x}; \xi, \eta, f, \epsilon)$  of the problem defined by equations (2.11a,b,c) actually is identical to the "limit Green function" obtained by replacing  $\zeta$  by zero in the previously-derived solution  $G(\vec{x}; \vec{\xi}, f, \epsilon)$  of the problem defined by equations (2.1a,b,c). Problem (2.11) may be solved in the same manner as was used previously for solving

problem (2.3), namely by using a double Fourier transform with respect to the horizontal coordinates  $x$  and  $y$ . We may then obtain the "Fourier-transformed problem:

$$\begin{aligned} d^2 G_\ell^{**} / dz^2 - k^2 G_\ell^{**} &= 0 \text{ in } z < 0, \\ dG_\ell^{**} / dz - f(1+i\epsilon)^2 G_\ell^{**} &= -\exp[i(\alpha\xi + \beta\eta)] / 2\pi \text{ on } z = 0, \\ G_\ell^{**} &\rightarrow 0 \text{ as } z \rightarrow -\infty, \end{aligned}$$

where  $G_\ell^{**}$  is the double-Fourier transform of  $G_\ell$ , as is defined by formula (2.4). The solution of the above problem is given by

$$G_\ell^{**} = -\exp[kz + i(\alpha\xi + \beta\eta)] / 2\pi [k - f(1+i\epsilon)^2].$$

By taking the inverse double Fourier transform, as is given by formula (2.8), we can finally obtain

$$G_\ell(\vec{x}; \xi, \eta, f, \epsilon) = \frac{-1}{4\pi^2} \int_{-\infty}^{\infty} d\beta \int_{-\infty}^{\infty} d\alpha \frac{e^{kz - i(\alpha x' + \beta y')}}{k - f(1+i\epsilon)^2}, \quad (2.12)$$

which can readily be verified to be identical to the expression obtained by replacing  $\zeta$  by zero in formula (2.9b).

Conversely, it may be shown that the "limit Green function"  $G_\ell$  given by expression (2.12) does in fact verify equations (2.11a,b,c). Verification of equations (2.11a) and 2.11c) can easily be checked. As for the free-surface condition (2.11b), we have

$$G_{\ell z} - f(1+i\epsilon)^2 G_\ell = -\left(\frac{1}{2\pi}\right) \int_{-\infty}^{\infty} e^{-i\alpha x'} d\alpha \left(\frac{1}{2\pi}\right) \int_{-\infty}^{\infty} e^{-i\beta y'} d\beta \text{ on } z = 0,$$

from which we may obtain

$$G_{\ell z} - f(1+i\epsilon)^2 G_\ell = -\delta(x') \delta(y') = -\delta(x-\xi) \delta(y-\eta) \text{ on } z = 0$$

by virtue of the relations

$$1 = \int_{-\infty}^{\infty} e^{i\alpha x} \delta(x) dx, \quad \delta(x) = \frac{1}{2\pi} \int_{-\infty}^{\infty} e^{-i\alpha x} d\alpha,$$

expressing the (well-known) fact that  $\delta(x)$  and 1 are Fourier transforms.

It may thus be seen, in summary, that the Green function  $G(\vec{x}; \vec{\xi}, f, \epsilon)$  of the theory of flow about a body in regular waves (where the limit  $\epsilon = +0$  is ultimately implied) verifies the following equations

$\nabla^2 G = \delta(x-\xi)\delta(y-\eta)\delta(z-\zeta) \quad \text{in } z < 0,$	}	if $\zeta < 0$	(2.13a)
$G_z - f(1+i\epsilon)^2 G = 0 \quad \text{on } z = 0,$	}	if $\zeta < 0$	(2.13b)
$G = 0(1/r) \quad \text{as } r \rightarrow \infty,$	}	if $\zeta < 0$	(2.13c)
$\nabla^2 G = 0 \quad \text{in } z < 0,$	}	if $\zeta = 0$	(2.14a)
$G_z - f(1+i\epsilon)^2 G = -\delta(x-\xi)\delta(y-\eta) \quad \text{on } z = 0,$	}	if $\zeta = 0$	(2.14b)
$G = 0(1/r) \quad \text{as } r \rightarrow \infty.$	}	if $\zeta = 0$	(2.14c)

As it was noted previously, the Green function only depends on the three space variables  $(x-\xi)^2 + (y-\eta)^2$ ,  $(z-\zeta)^2$ , and  $(z+\zeta)$ , so that this function is invariant under the substitution  $\vec{x} \leftrightarrow \vec{\xi}$ . Physically, the velocity potential  $\text{Re}G(\vec{x}; \vec{\xi}, f, \epsilon) \exp(\epsilon-i)t$  of the flow created at point  $\vec{x}(x, y, z \leq 0)$  by an outflow of strength  $\text{Re} \exp(\epsilon-i)t$  at point  $\vec{\xi}(\xi, \eta, \zeta \leq 0)$ , stemming from a submerged source if  $\zeta < 0$  or a free-surface flux if  $\zeta = 0$ , is identical to the potential  $\text{Re}G(\vec{\xi}; \vec{x}, f, \epsilon) \exp(\epsilon-i)t$  of the flow created at point  $\vec{\xi}$  by an outflow  $\text{Re} \exp(\epsilon-i)t$  at point  $\vec{x}$ , stemming from a source if  $z < 0$  or a free-surface flux if  $z = 0$ . It then follows that equations (2.13) and (2.14) are also verified by the function  $G(\vec{\xi}; \vec{x}, f, \epsilon)$ .

In the zero- and infinite- frequency limits ( $f=0, \infty$ ), the Green function  $G$  becomes

$$\boxed{4-G^0 = -1/r - 1/r'} \quad , \quad \boxed{4\pi G^\infty = -1/r + 1/r'} \quad , \quad (2.15a, b)$$

respectively, as may be obtained from formulas (2.10a) and (2.10b), respectively.

The zero-frequency Green function  $G^0(\vec{\xi}; \vec{x})$  verifies the equations

$$\left. \begin{aligned} \nabla^2 G^0 &= \delta(x-\xi) \delta(y-\eta) \delta(z-\zeta) \quad \text{in } z < 0, \\ G_z^0 &= 0 \quad \text{on } z = 0, \end{aligned} \right\} \text{if } \zeta < 0, \quad (2.16)$$

$$\left. \begin{aligned} \nabla^2 G^0 &= 0 \quad \text{in } z < 0, \\ G_z^0 &= -\delta(x-\xi) \delta(y-\eta) \quad \text{on } z = 0, \end{aligned} \right\} \text{if } \zeta = 0,$$

whereas the infinite-frequency Green function  $G^\infty(\vec{\xi}; \vec{x})$  verifies the equations

$$\left. \begin{aligned} \nabla^2 G^\infty &= \delta(x-\xi) \delta(y-\eta) \delta(z-\zeta) \quad \text{in } z < 0, \\ G^\infty &= 0 \quad \text{on } z = 0, \end{aligned} \right\} \text{if } \zeta < 0, \quad (2.17)$$

$$G^\infty \equiv 0 \quad \text{if } \zeta = 0.$$

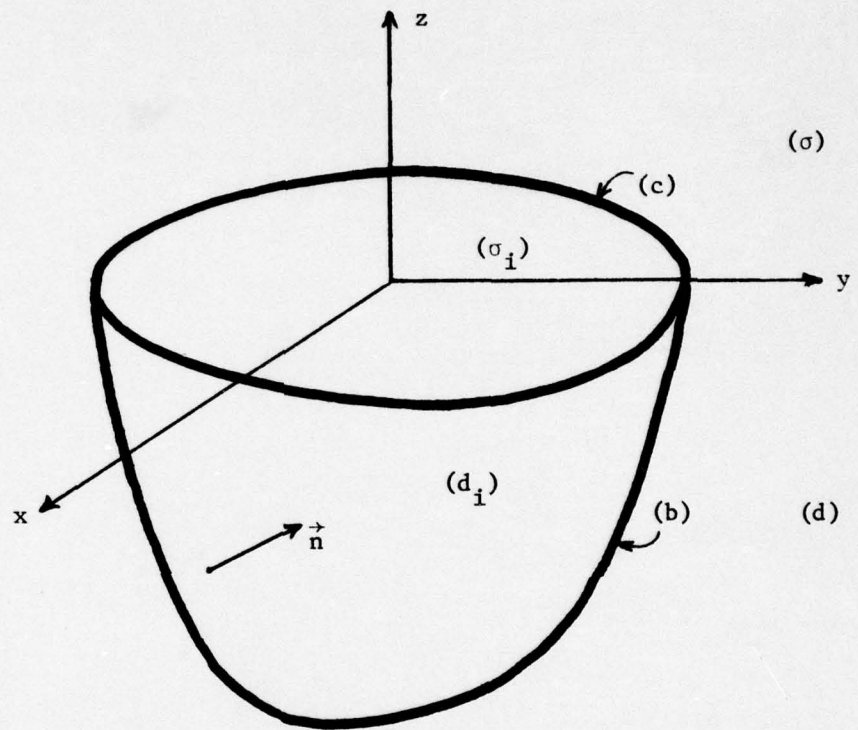

Definition sketch

### 3. Basic integral identities

In this section, basic integral identities for the velocity potential  $\phi(\vec{x})$  are obtained by applying a classical Green identity to the function  $\phi(\vec{x})$  and the Green function  $G(\vec{\xi};\vec{x},f,\epsilon)$  defined in the previous section. The above-mentioned classical Green identity is

$$\int_d (\phi \nabla^2 G - G \nabla^2 \phi) dv = \int_\sigma (\phi G_z - G \phi_z) dx dy + \int_b (\phi G_n - G \phi_n) da, \quad (3.1)$$

where the fact that  $\phi = O(1/r)$  and  $G = O(1/r)$  as  $r \rightarrow \infty$  was used to discard the integral of  $\phi G_n - G \phi_n = O(1/r^3)$  over a large surrounding half sphere of radius  $r$  (surface area  $\sim r^2$ ). In formula (3.1), as indeed hereafter in this study, the following notation is used:  $\phi \equiv \phi(\vec{x})$ ,  $G \equiv G(\vec{\xi};\vec{x},f,\epsilon)$ ,  $\nabla \equiv (\partial_x, \partial_y, \partial_z)$ ,  $G_z \equiv \partial G / \partial z$ ,  $G_n \equiv \partial G / \partial n \equiv \nabla G \cdot \vec{n}$ , and likewise  $\phi_n \equiv \partial \phi / \partial n \equiv \nabla \phi \cdot \vec{n}$ , where  $\vec{n} \equiv \vec{n}(\vec{x})$  is the unit normal vector at point  $\vec{x}$  of the body surface (b) pointing outside the solution domain (d) as was defined in section 1; furthermore,  $dv \equiv dv(\vec{x})$  and  $da \equiv da(\vec{x})$  represent the differential elements of volume and area at point  $\vec{x}$  of (d) and (b) respectively, while  $dx dy$  evidently is the differential element of area of the mean free surface ( $\sigma$ ).

By expressing the term  $\phi G_z - G \phi_z$  in the form  $\phi [G_z - f(1+i\epsilon)^2 G] - G [\phi_z - f(1+i\epsilon)^2 \phi]$ , equation (3.1) can be written as

$$\int_d \phi \nabla^2 G dv - \int_\sigma \phi [G_z - f(1+i\epsilon)^2 G] dx dy = \int_d G \nabla^2 \phi dv - \int_\sigma G [\phi_z - f(1+i\epsilon)^2 \phi] dx dy - \int_b (\phi G_n - G \phi_n) da. \quad (3.2)$$

Let us now express  $\phi$  in the two integrals on the left side of equation (3.2) in the form  $\phi_* + \phi - \phi_*$ , where  $\phi \equiv \phi(\vec{x})$  as was defined previously, and  $\phi_*$  is defined as  $\phi(\vec{\xi})$ , i.e.  $\phi_* \equiv \phi(\vec{\xi})$ . We may then obtain

$$\int_d \phi \nabla^2 G dv - \int_\sigma \phi [G_z - f(1+i\epsilon)^2 G] dx dy = C \phi_* + C', \quad (3.3)$$

where  $C$  and  $C'$  are defined as

$$C = \int_d \nabla^2 G dv - \int_\sigma [G_z - f(1+i\epsilon)^2 G] dx dy, \quad (3.4)$$

$$C' = \int_d (\phi - \phi_*) \nabla^2 G dv - \int_\sigma (\phi - \phi_*) [G_z - f(1+i\epsilon)^2 G] dx dy.$$

It follows from equations (2.13a,b) and (2.14a,b), and the fact that  $(\phi - \phi_*) = 0$  when the points  $\vec{x}$  and  $\vec{\xi}$  coincide, that we have  $C' \equiv 0$  for any point  $\vec{\xi}$  in the lower half space  $z \leq 0$ . By using equation (3.3), with  $C' \equiv 0$ , into equation (3.2), we can then obtain

$$C\phi_* = \int_d G \nabla^2 \phi dv - \int_\sigma G [\phi_z - f(1+i\epsilon)^2 \phi] dx dy - \int_b (G\phi_n - \phi G_n) da, \quad (3.5)$$

where  $C$  is given by formula (3.4).

By using equations (2.13a,b) and (2.14a,b) in expression (3.4) for  $C$ , it can be seen that we have  $C \equiv 1$  if the point  $\vec{\xi}$  is strictly outside the body surface (b), either in (d) or on ( $\sigma$ ), while we have  $C \equiv 0$  if  $\vec{\xi}$  is strictly inside (b). We thus have

$$\phi_* = \int_d G \nabla^2 \phi dv - \int_\sigma G [\phi_z - f(1+i\epsilon)^2 \phi] dx dy - \int_b (G\phi_n - \phi G_n) da \quad (3.6a)$$

for  $\vec{\xi}$  in  $(d) + (\sigma) - (b) - (c)$ , where (c) is the intersection curve of (b) with the plane  $z=0$  [in the case (b) does in fact intersect the plane  $z=0$ ], and

$$0 = \int_d G \nabla^2 \phi dv - \int_\sigma G [\phi_z - f(1+i\epsilon)^2 \phi] dx dy - \int_b (G\phi_n - \phi G_n) da \quad (3.6b)$$

for  $\vec{\xi}$  in  $(d_1) + (\sigma_1) - (b) - (c)$ , where  $(d_1)$  and  $(\sigma_1)$  represent the domain and the portion of the plane  $z=0$ , respectively, which are strictly inside the body surface (b)+(c), so that  $(d) + (d_1) + (b)$  and  $(\sigma) + (\sigma_1) + (c)$  are the whole lower half space  $z < 0$  and the entire plane  $z=0$ , respectively. It can also easily be seen from equations (2.13a,b), (2.14a,b), and (3.4) that we have  $C=1/2$  if the point  $\vec{\xi}$  is right on the body surface (b) or its intersection (c) with the plane  $z=0$ , at least for points  $\vec{\xi}$  where (b)+(c) is smooth; more generally the value of  $4\pi C$  (or  $2\pi C$ ) at a point  $\vec{\xi}$  of (b) (or (c)) is equal to the angle under which (d) (or ( $\sigma$ )) is viewed from the point  $\vec{\xi}$ . We then have

$$\left[ \frac{1}{2} \phi_{*} = \int_{d} G \nabla^2 \phi dv - \int_{\sigma} G [\phi_z - f(1+i\epsilon)^2 \phi] dx dy - \int_b (G \phi_n - \phi G_n) da \right] \quad (3.6c)$$

for  $\vec{\xi}$  exactly on (b)+(c). Equations (3.6a,b,c) are quite well known of course, although the particular case of these equations corresponding to  $\nabla^2 \phi = 0 = \phi_z - f(1+i\epsilon)^2 \phi$  is usually given in the literature, and the traditional derivation of these equations from the Green identity (3.1) is somewhat different from that shown above.

As it is explicitly indicated in equation (3.6a,b,c), the value of the constant C on the left side of equation (3.5) is discontinuous across the body surface, C being equal to 1 outside the body and to 0 inside. This discontinuity in the value of C on the left side of equation (3.5) evidently is accompanied by a corresponding discontinuity on the right side of the equation. Specifically, the latter discontinuity stems from the integral  $\int_b \phi G_n da$  representing the potential induced by a surface distribution of normal doublets of strength  $\phi$  over (b), as is well known. An integral identity valid for any point  $\vec{\xi}$ --either outside, inside, or right on the body surface--can be obtained by eliminating the discontinuity in the value of C in equation (3.5). This can readily be achieved by adding the term  $C_i \phi_{*}$  on both the left and right sides of equation (3.5), with  $C_i$  given by

$$C_i = \int_{d_i} \nabla^2 G dv - \int_{\sigma_i} [G_z - f(1+i\epsilon)^2 G] dx dy.$$

Equation (3.5) then becomes

$$\begin{aligned} I \phi_{*} = & \int_d G \nabla^2 \phi dv - \int_{\sigma} G [\phi_z - f(1+i\epsilon)^2 \phi] dx dy - \int_b (G \phi_n - \phi G_n) da + \\ & + \phi_{*} \left\{ \int_{d_i} \nabla^2 G dv - \int_{\sigma_i} [G_z - f(1+i\epsilon)^2 G] dx dy \right\} \end{aligned} \quad (3.7)$$

where I is defined as

$$I = \int_{d+d_i} \nabla^2 G dv - \int_{\sigma+\sigma_i} [G_z - f(1+i\epsilon)^2 G] dx dy .$$

It can be seen from equations (2.13a,b) and (2.14a,b) that we have  $I \equiv 1$  for any point  $\vec{\xi}$  in the lower half space  $z < 0$ . By using the divergence theorem

$$\int_{d_i} \nabla^2 G dv = \int_{\sigma_i} G_z dx dy - \int_b G_n da \quad (3.8)$$

in equation (3.7), where  $I$  is taken as 1, we may finally obtain

$$(1-w_*)\phi_* = \int_d G \nabla^2 \phi dv - \int_{\sigma} G[\phi_z - f(1+i\epsilon)^2 \phi] dx dy - \int_b [G\phi_n - (\phi - \phi_*)G_n] da, \quad (3.9)$$

where the function  $w_* \equiv w(\vec{\xi}; f, \epsilon, \sigma_i)$  is the "waterplane integral" given by

$$w(\vec{\xi}; f, \epsilon, \sigma_i) = f(1+i\epsilon)^2 \int_{\sigma_i} G(\vec{\xi}; \vec{x}, f, \epsilon) dx dy. \quad (3.9a)$$

An interesting alternative form of the integral identity (3.9) involving a "modified Green function"  $\tilde{G}$  can be obtained by dividing both sides of this identity by  $(1-w_*)$ . This yields

$$\phi_* = \int_d \tilde{G} \nabla^2 \phi dv - \int_{\sigma} \tilde{G}[\phi_z - f(1+i\epsilon)^2 \phi] dx dy - \int_b [\tilde{G}\phi_n - (\phi - \phi_*)\tilde{G}_n] da, \quad (3.10)$$

where the "modified Green function"  $\tilde{G}$  is given by  $\tilde{G} = G/(1-w_*)$ , that is

$$\tilde{G}(\vec{\xi}; \vec{x}, f, \epsilon, \sigma_i) = G(\vec{\xi}; \vec{x}, f, \epsilon) / [1 - f(1+i\epsilon)^2 \int_{\sigma_i} G(\vec{\xi}; \vec{x}, f, \epsilon) dx dy]. \quad (3.10a)$$

In the case of a fully-submerged body, we evidently have  $(\sigma_i) \equiv 0$ , so that the "waterplane integral"  $w$  then vanishes and the "modified Green function"  $\tilde{G}$  becomes identical to the usual Green function  $G$ , that is we have  $w \equiv 0$  and  $\tilde{G} \equiv G$ .

The integral identity (3.9) is valid for any point  $\vec{\xi}$  either outside, inside, or exactly on the body surface. This new identity thus is essentially equivalent to the set of the three classical identities (3.6a,b,c),

which are valid exclusively for  $\vec{\xi}$  outside, inside, or on the body surface, respectively. As a matter of fact, these three identities can readily be obtained from the identity (3.9) by verifying that we have  $w_* - \int_b G_n da = 0, 1, \text{ or } 1/2$  for  $\vec{\xi}$  outside, inside, or on the body surface, respectively, as is shown below. From equation (3.9a), we have

$$w_* - \int_b G_n da = f(1+i\epsilon)^2 \int_{\sigma_i} G dx dy - \int_b G_n da =$$

$$\int_{\sigma_i} G_z dx dy - \int_b G_n da - \int_{\sigma_i} [G_z - f(1+i\epsilon)^2 G] dx dy =$$

$$\int_{d_i} \nabla^2 G dv - \int_{\sigma_i} [G_z - f(1+i\epsilon)^2 G] dx dy,$$

where the divergence theorem (3.8) was used; the above-stated result then follows from equations (2.13a,b) and (2.14a,b).

Although the present study is primarily concerned with the "exterior potential-flow problem", i.e. the problem of potential flow about a body, it may be of some interest to list here the integral identities corresponding to equations (3.6a,b,c) and equations (3.9) and (3.10) for the "interior potential",  $\phi^i$  say, defined in the interior domain ( $d_i$ ) bounded by (b)+( $\sigma_i$ )+(c). The integral identities corresponding to equations (3.6a,b,c) can be shown to take the forms

$$\boxed{\phi_*^i = \int_{d_i} G \nabla^2 \phi^i dv - \int_{\sigma_i} G [\phi_z^i - f(1+i\epsilon)^2 \phi^i] dx dy + \int_b (G \phi_n^i - \phi^i G_n) da}, \quad (3.11a)$$

for  $\vec{\xi}$  in ( $d_i$ )+( $\sigma_i$ )-(b)-(c), that is inside the body,

$$\boxed{0 = \int_{d_i} G \nabla^2 \phi^i dv - \int_{\sigma_i} G [\phi_z^i - f(1+i\epsilon)^2 \phi^i] dx dy + \int_b (G \phi_n^i - \phi^i G_n) da}, \quad (3.11b)$$

for  $\vec{\xi}$  in (d)+( $\sigma$ )-(b)-(c), i.e. outside the body, and

$$\left. \frac{1}{2}\phi_*^i = \int_{d_i} G\nabla^2\phi^i dv - \int_{\sigma_i} G[\phi_z^i - f(1+i\epsilon)^2\phi^i] dx dy + \int_b (G\phi_n^i - \phi^i G_n^i) da \right|, \quad (3.11c)$$

for  $\vec{\xi}$  exactly on (b)+(c).

The integral identity corresponding to equation (3.9) takes the form

$$\left. w_*\phi_*^i = \int_{d_i} G\nabla^2\phi^i dv - \int_{\sigma_i} G[\phi_z^i - f(1+i\epsilon)^2\phi^i] dx dy + \int_b [G\phi_n^i - (\phi^i - \phi_*^i)G_n^i] da \right|, \quad (3.12)$$

where the function  $w_* \equiv w(\vec{\xi}; f, \epsilon, \sigma_i)$  is the "waterplane integral" defined by formula (3.9a). The integral relation (3.12), like equation (3.9), is valid for any point  $\vec{\xi}$ , either inside, outside or exactly on the body surface, and thus is equivalent to the set of the three classical identities (3.11a,b,c). An alternative form of the integral identity (3.12) involving a "modified Green function"  $G^i$  is

$$\left. \phi_*^i = \int_{d_i} G^i \nabla^2 \phi^i dv - \int_{\sigma_i} G^i [\phi_z^i - f(1+i\epsilon)^2 \phi^i] dx dy + \int_{b_i} [G^i \phi_n^i - (\phi^i - \phi_*^i) G_n^i] da \right|, \quad (3.13)$$

where the function  $G^i$  is given by  $G^i = G/w_*$ , that is

$$\left. G^i(\vec{\xi}; \vec{x}, f, \epsilon, \sigma_i) = G(\vec{\xi}; \vec{x}, f, \epsilon) / f(1+i\epsilon)^2 \int_{\sigma_i} G(\vec{\xi}; \vec{x}, f, \epsilon) dx dy \right|. \quad (3.13a)$$

The case of a fully-submerged body evidently is a degenerate case for which the boundary condition at the free surface becomes meaningless.

It is interesting to note that whereas the classical identities (3.6a,b,c) and (3.11a,b,c) for the exterior and interior potential-flow problems, respectively, are identical (provided only one properly interchanges the terms "exterior" and "interior"), the relations (3.9) and (3.12), or the equivalent alternative relations (3.10) and (3.13), clearly are not identical. Specifically, the factor  $(1-w_*)$  in relation (3.9) for the exterior problem becomes  $w_*$  in relation (3.12) for the interior problem, and the

equivalent relations (3.10) and (3.13), although identical in form, involve different "modified Green functions", namely the "modified exterior Green function"  $\tilde{G} \equiv G/(1-w_*)$  and the "modified interior Green function"  $G^i \equiv G/w_*$ .

If we add the integral relations (3.6a) and (3.11b), we may obtain the relation

$$\begin{aligned} \phi_* = & \int_d G \nabla^2 \phi dv + \int_{d_i} G \nabla^2 \phi^i dv - \int_\sigma G [\phi_z - f(1+i\epsilon)^2 \phi] dx dy - \int_{\sigma_i} G [\phi_z^i - f(1+i\epsilon)^2 \phi^i] dx dy \\ & + \int_b [G(\phi_n^i - \phi_n) - (\phi^i - \phi) G_n] da. \end{aligned}$$

Addition of equations (3.6b) and (3.11a) yields the same relation, with  $\phi_*$  on the left side merely replaced by  $\phi_*^i$ . We therefore have the relation

$$\boxed{\phi_* = \int_{z<0} G \nabla^2 \phi dv - \int_{z=0} G [\phi_z - f(1+i\epsilon)^2 \phi] dx dy + \int_b [G(\phi_n^i - \phi_n) - (\phi^i - \phi) G_n] da}, \quad (3.14)$$

where  $\phi$  on the left side and in the first two integrals on the right side clearly corresponds to  $\phi$  or  $\phi^i$  for points outside or inside, respectively, the body surface (b)+(c). The integral relation (3.14) expresses the potential  $\phi(\vec{\xi})$  in the lower-half space  $z \leq 0$  in terms of a volume distribution of sources (with density  $\nabla^2 \phi$ ), a free-surface flux (or pressure) distribution [with flux  $q = f(1+i\epsilon)^2 \phi - \phi_z$ ], and surface distributions of sources (with density  $\phi_n^i - \phi_n$ ) and of normal dipoles (with density  $\phi - \phi^i$ ) over the surface (b). Two classical results in potential theory immediately follow from equation (3.14): namely, (i) a distribution of normal dipoles (say of strength  $\delta$ ) on a surface (say S) generates a potential  $\phi = \int_S \delta G_n da$  whose value is discontinuous across the surface S (specifically, we have  $\phi^e - \phi^i = \delta$ , where the superscripts e and i refer to the "exterior" and "interior" sides of S, respectively; the "interior" side being that into which the unit normal vector  $\vec{n}$  is drawn), and (ii) a distribution of sources (strength  $\sigma$ ) over a surface S generates a potential  $\phi = \int_S \sigma G da$  whose normal derivative  $\phi_n$  is discontinuous across S (specifically) we have  $\phi_n^i - \phi_n^e = \sigma$ . It may finally be worthwhile to verify that equation (3.14) can (naturally) also be obtained by

adding equations (3.9) and (3.12). Indeed, this yields

$$(1-C_i)\phi_* + C_i\phi_*^i = \int_{z<0} G\nabla^2\phi dv - \int_{z=0} G[\phi_z - f(1+i\epsilon)^2\phi]dxdy + \int_b [G(\phi_n^i - \phi_n) - (\phi^i - \phi)G_n]da,$$

where  $C_i$  is defined as

$$C_i = w_* - \int_b G_n da = \begin{cases} 1 \\ 0 \end{cases} \text{ for } \vec{\xi} \text{ in } \begin{cases} (d_i) + (\sigma_i) - (b) - (c) \\ (d) + (\sigma) - (b) - (c) \end{cases},$$

as was shown previously. It then follows that the expression  $(1-C_i)\phi_* + C_i\phi_*^i$  is identical to  $\phi_*$  or  $\phi_*^i$  for  $\vec{\xi}$  outside or inside, respectively, the body surface  $(b)+(c)$ , and the above relation thus is identical with relation (3.14).

In the zero-frequency limit ( $f=0$ ), the integral identity corresponding to identity (3.9) takes the form

$$\phi_*^0 = \int_d G^0 \nabla^2 \phi^0 dv - \int_\sigma G^0 \phi_z^0 dx dy - \int_b [G^0 \phi_n^0 - (\phi^0 - \phi_*^0) G_n^0] da, \quad (3.15)$$

where  $G^0$  is the zero-frequency Green function given by formula (2.15a), and  $\phi^0$  is the zero-frequency potential, which verifies a free-surface condition like equation (1.7a). The zero-frequency integral identity (3.15) may readily be obtained as the zero-frequency limit of the integral identity (3.9), or it may be derived directly by using equations (2.16) in the Green identity (3.1). In the infinite-frequency limit ( $f=\infty$ ), on the other hand, the integral identity corresponding to identities (3.9) and (3.15) takes the form

$$(1-w_*^\infty)\phi_*^\infty = \int_d G^\infty \nabla^2 \phi^\infty dv + \int_\sigma \phi^\infty G_z^\infty dx dy - \int_b [G^\infty \phi_n^\infty - (\phi^\infty - \phi_*^\infty) G_n^\infty] da, \quad (3.16)$$

as may be obtained by using equations (2.17) in the Green identity (3.1). In equation (3.16),  $G^\infty$  is the infinite-frequency Green function given by formula (2.15b),  $\phi^\infty$  is the infinite-frequency potential, which verifies a free-surface condition like equation (1.7b), and the function  $w_*^\infty \equiv w^\infty(\vec{\xi}; \sigma_i)$  is defined by

$$w_*^\infty = \int_{\sigma_1} G_z^\infty dx dy .$$

It may easily be seen that all the terms in equation (3.16) are continuous at the body surface (b) if  $\zeta < 0$ . It can also be seen that, in the limit  $\zeta = -0$ , the first and last integrals on the right side of equation (3.16) vanish, while the function  $w_*^\infty$  and the second integral on the right side (i.e. the two free-surface integrals involving  $G_z^\infty$ ) are discontinuous at the intersection curve (c) of the body surface (b) and the mean free-surface plane  $\zeta = 0$ ; specifically, the term  $(1 - w_*^\infty) \phi_*^\infty$  on the left side and the integral  $\int_{\sigma} \phi^\infty G_z^\infty dx dy$  may be shown to be equal to  $0, \phi_*^\infty/2$ , and  $\phi_*^\infty$  for  $\vec{\xi}(\xi, \eta, \zeta = -0)$  on  $(\sigma_1), (c)$  [wherever (c) is smooth], and  $(\sigma)$ , respectively.

#### 4. Applications and discussion

In the particular case when we do not have a body (b), equations (3.6b) and (3.6c) evidently become meaningless, while both equations (3.6a) and (3.9) can readily be seen to become

$$\phi_* = \int_{z<0} G \nabla^2 \phi \, dv - \int_{z=0} G [\phi_z - f(1+i\epsilon)^2 \phi] \, dx \, dy \quad .$$

This formula provides an explicit solution to the problem of determining the velocity potential  $\phi$  when  $\nabla^2 \phi$  and  $\phi_z - f(1+i\epsilon)^2 \phi$  are given in the lower-half space  $z<0$  and on the mean free surface  $z=0$ , respectively. A classical problem in this category is that of determining the potential induced by a given distribution of pressure  $p$  (and possibly also of flux  $q$ ) at the free surface. The solution of this problem, which is stated in differential form by equations (1.6a,b,c), is then given by

$$\phi(\vec{\xi}) = - \int_{-\infty}^{\infty} \int_{-\infty}^{\infty} G(\vec{\xi}; x, y, z=0, f, \epsilon) [if(1+i\epsilon)p(x, y) - q(x, y)] \, dx \, dy \quad .$$

This solution is well known of course, and can indeed be obtained by using other approaches than that adopted here. For instance, equations (1.6a,b,c) can be solved directly by means of a double Fourier transformation with respect to the horizontal variables  $x$  and  $y$ . Another often-used approach for determining the potential induced by a free-surface pressure distribution is based on the use of a special Green function,  $\bar{G}$  say, corresponding to the potential induced by a pressure impulse  $p(x, y) = \delta(x-\xi)\delta(y-\eta)$  at the free surface. This Green function  $\bar{G}$  in fact is essentially identical to the "limit Green function"  $G_\rho$  [more precisely, we have  $\bar{G} = -if(1+i\epsilon)G_\rho$ ] defined by equations (2.11a,b,c) and given by formula (2.12). The "free-surface pressure impulse" Green function  $\bar{G}$  thus is merely a particular case (corresponding to  $z=0$ ) of the Green function  $G$  defined in this study, so that introduction of this special Green function  $\bar{G}$  is obviously not necessary.

A particular problem that is more difficult, and also more important from the point of view of practical applications, than the above-discussed problem of flow induced by a free-surface pressure distribution is the problem

of flow about an arbitrary body in regular waves, for which we have  $\nabla^2 \phi = 0$  in the mean flow domain (d) and  $p = 0 = q$ , and hence  $\phi_z - f(1+i\epsilon)^2 \phi = 0$ , on the mean free surface (o) in the usual linearized approximation. The integral identities given in the previous section evidently do not provide an explicit solution for this problem as they did in the previous case of flow induced by a free-surface pressure distribution in the absence of a body. However, identities (3.6c) and (3.9) provide integral equations for determining the potential  $\phi_* \equiv \phi(\vec{\xi})$  on the body surface (b) + (c). These integral equations take the form

$$\boxed{\frac{1}{2} \phi_* = - \int_b G \phi_n da + \int_b \phi G_n da} \quad , \quad (4.1)$$

$$\boxed{(1-w_*) \phi_* = - \int_b G \phi_n da + \int_b (\phi - \phi_*) G_n da} \quad , \quad (4.2)$$

corresponding to equations (3.6c) and (3.9), respectively. An alternative form, corresponding to equation (3.10), of the integral equation (4.2) is

$$\boxed{\phi_* = - \int_b \tilde{G} \phi_n da + \int_b (\phi - \phi_*) \tilde{G}_n da} \quad . \quad (4.2a)$$

A notable feature of the new integral equation (4.2), or of the equivalent equation (4.2a), is that the last integrals on the right sides of these equations are continuous functions of  $\vec{\xi}$  (since the dipole strength  $\phi - \phi_*$  vanishes as the "integration point"  $\vec{x}$  and the "field point"  $\vec{\xi}$  coincide), whereas the corresponding integral in the classical integral equation (4.1) is discontinuous at the body surface (b) + (c), as was discussed in the previous section and is indeed well known. As a matter of fact, the factor 1/2 on the left side of equation (4.1) is correct only at points  $\vec{\xi}$  where (b) + (c) is smooth, that is, has a tangent plane, as was also discussed in the previous section. The classical integral equation (4.1) requires evaluation of a discontinuous function (the function defined by the last integral on the right side) precisely on the surface of discontinuity, namely (b) + (c). This awkward and difficult problem, specially from the viewpoint of numerical

calculations, is avoided in the integral equations (4.2) or (4.2a). In fact, the integrands  $(\phi - \phi_*)G_n$  or  $(\phi - \phi_*)\tilde{G}_n$  can be shown to be non-singular (that is, to remain finite) for  $\vec{x} = \vec{\xi}$ , which evidently is advantageous for purposes of numerical calculations.

For simplicity, let the first integral on the right side of the integral equation (4.2) be denoted by  $\psi_* \equiv \psi(\vec{\xi})$ , that is we have

$$\boxed{\psi_* = - \int_b G \phi_n da} \quad . \quad (4.3)$$

This potential  $\psi_*$  is known in principle since  $\phi_n$  is given on (b). A choice of methods is available for solving the nonhomogeneous Fredholm integral equation (4.2). In particular, a natural method of solution consists in using an iterative procedure based on an appropriate recurrence relation. An obvious recurrence relation is that obtained by simply replacing  $\phi$  by  $\phi^{(k)}$  and  $\phi^{(k+1)}$  on the right and left sides, respectively, of equation (4.2), i.e.

$$(1 - w_*) \phi_*^{(k+1)} = \psi_* + \int_b (\phi^{(k)} - \phi_*^{(k)}) G_n da \quad , \quad k > 0 \quad , \quad (4.4)$$

where the initial (zeroth) approximation  $\phi^{(0)}$  must be specified somehow. The practical usefulness of such an iterative method of solution depends on fast convergence of the successive iterative approximations  $\phi^{(k)}$ , which in turn is crucially dependent on selection of a "reasonably-good" initial approximation  $\phi^{(0)}$ . In some particular problems, such an initial approximation is readily available; for instance, in the problems of wave radiation due to surging motions of a slender ship or to heaving and pitching motions of a thin (beam  $\ll$  length and draft) ship, we may simply take  $\phi^{(0)} \equiv 0$  (for swaying motions of a thin ship, on the other hand, this simple approximation clearly could not be used). For sufficiently low (or high) values of the frequency parameter  $f = \omega^2 L/g$ , the zero- (or infinite-) frequency potential  $\phi^0$  (or  $\phi^\infty$ ) might also be used as an initial approximation; more generally, a relatively-simple interpolation approximation such as  $(\phi^0 + f\phi^\infty)/(1+f)$ , which clearly reduces to  $\phi^0$  and  $\phi^\infty$  as  $f \rightarrow 0$  and  $f \rightarrow \infty$ , respectively, would seem likely to provide a reasonable initial approximation  $\phi^{(0)}$ .

Equation (4.2), like equation (3.9) of course, holds not only for  $\vec{\xi}$  on the body surface (b)+(c), but also for  $\vec{\xi}$  outside (and inside) the body. This means that the integral equation (4.2) can in principle be used to determine the potential  $\phi$  in the entire solution domain (d)+(σ)+(b)+(c), specifically by means of the recurrence relation (4.4). In practice however, it would usually be much simpler to solve for  $\phi$  on the body surface (b)+(c), and — in the event (rare in reality) that knowledge of  $\phi$  in the flow domain is in fact required — to determine  $\phi$  outside (b)+(c) by means of equation (3.6a), which here takes the simplified form

$$\phi_* = - \int_b G \phi_n da + \int_b \phi G_n da \quad . \quad (4.5)$$

Equation (4.2) also holds for  $\vec{\xi}$  inside the body, as was noted previously. It thus might appear that this integral equation must also define the potential  $\phi$  inside the body. This result, were it to be true, would certainly be quite surprising (indeed fundamentally unacceptable) for it would mean that the "exterior boundary-value problem" stated by equations (1.6a,b,c,d) would define a solution in the "interior domain" (d<sub>1</sub>)+(σ<sub>1</sub>)-(b)-(c). It can easily be shown, however, that equation (4.2) allows the potential  $\phi$  to be extended inside (b)+(c) in an entirely arbitrary manner. Indeed, equation (4.2) can be written in the form

$$C \phi_* = - \int_b G \phi_n da + \int_b \phi G_n da \quad , \quad (4.6)$$

where  $C$  is given by  $C = 1 - w_* + \int_b G_n da$ . We have  $C \equiv 0$  for  $\vec{\xi}$  inside (b)+(c), as may easily be verified (and has indeed been shown in the previous section), so that equation (4.6) clearly does not define  $\phi_*$  inside (b)+(c). For  $\vec{\xi}$  outside (b)+(c), on the other hand, we have  $C \equiv 1$ , and equation (4.6) becomes equation (4.5), which obviously defines  $\phi_*$ .

A simple explanation for the origin of the "waterplane integral"  $w_* \equiv w(\vec{\xi}; f, \epsilon, \sigma_1)$  defined by formula (3.9a) in the integral equation (4.2) in the case of a free-surface piercing body [this "waterplane integral" does not appear in the case of a fully-submerged body] may be provided by considering a free-surface piercing body as the "zero-submergence limit" of a slightly

submerged body consisting of the mean wetted body surface (b) closed by a horizontal "lid", ( $\ell$ ) say, submerged a depth  $\delta$  below the mean free-surface plane  $z=0$ , so that the "lid" ( $\ell$ ) becomes the "interior waterplane" ( $\sigma_1$ ) in the limit  $\delta \rightarrow 0$ . For the fully-submerged body (b)+( $\ell$ ), the integral equation (4.2) takes the form

$$\begin{aligned}\phi_* &= - \int_{b+\ell} G\phi_n da + \int_{b+\ell} (\phi-\phi_*)G_n da \\ &= - \int_b G\phi_n da + \int_b (\phi-\phi_*)G_n da + \int_{\ell} G\phi_z dx dy - \int_{\ell} (\phi-\phi_*)G_z dx dy \quad ,\end{aligned}$$

where the fact that  $\phi_n \equiv -\phi_z$  on the "lid" ( $\ell$ ) was used. By Expressing the terms  $\phi_z$  and  $G_z$  in the forms  $\phi_z - f(1+i\epsilon)^2\phi + f(1+i\epsilon)^2\phi$  and  $G_z - f(1+i\epsilon)^2G + f(1+i\epsilon)^2G$ , we may then obtain

$$\begin{aligned}\phi_* &= - \int_b G\phi_n da + \int_b (\phi-\phi_*)G_n da + \phi_* f(1+i\epsilon)^2 \int_{\ell} G dx dy + \\ &+ \int_{\ell} G[\phi_z - f(1+i\epsilon)^2\phi] dx dy - \int_{\ell} (\phi-\phi_*)[G_z - f(1+i\epsilon)^2G] dx dy \quad .\end{aligned}$$

We have  $\phi_z - f(1+i\epsilon)^2\phi = 0$  on the mean free-surface plane  $z=0$ , so that  $[\phi_z - f(1+i\epsilon)^2\phi]_{z=-\delta}$  vanish as  $\delta \rightarrow 0$ . Likewise, we have  $(\phi-\phi_*)[G_z - f(1+i\epsilon)^2G] \rightarrow 0$  as  $\delta \rightarrow 0$ . The last two integrals on the right side of the above equation thus vanish in the limit  $\delta \rightarrow 0$ , and this equation may then be seen to become identical to equation (4.2) in this limit. Moreover, the term  $w_*\phi_*$  in equation (4.2) for a free-surface piercing body (b) can be seen to stem from the effect of the "lid" ( $\ell$ ) in the integral equation for the slightly submerged body (b)+( $\ell$ ).

A modified form of the integral equation (4.2) can be obtained by expressing the potential  $\phi_* \equiv \phi(\vec{\xi})$  in the form  $\phi_* = k_*\chi_*$ , where  $\chi_* \equiv \chi(\vec{\xi})$  is some given potential (to be selected somehow), and  $k_* \equiv k(\vec{\xi})$  is the function defined by the relation  $k_* = \phi_*/\chi_*$ . By substituting this expression for  $\phi_*$  into equation (4.2) and expressing the term  $\phi-\phi_* \equiv k\chi - k_*\chi_*$  in the form  $k_*(\chi - \chi_*) + (k-k_*)\chi$ , we may obtain the following integral equation for the function  $k(\vec{\xi})$ :

$$[(1-w_*)\chi_* - \int_b (\chi-\chi_*)G_n da]k_* = \psi_* + \int_b (k-k_*)\chi G_n da \quad (4.7a)$$

The last integral on the right side of the above integral equation would evidently vanish if  $k \equiv k_*$  for  $\vec{x}$  and  $\vec{\xi}$  on the body surface (b), that is if  $k \equiv \phi/\chi$  is constant on (b), or if  $\chi$  is proportional to  $\phi$  on (b). The integral equation (4.7a) would then yield the explicit solution

$$k_* = \psi_* / [(1-w_*)\chi_* - \int_b (\chi-\chi_*)G_n da] \quad (4.7b)$$

from which we may immediately obtain the following expression for the velocity potential  $\phi_* \equiv k_*\chi_*$ :

$$\phi_* = \chi_*\psi_* / [(1-w_*)\chi_* - \int_b (\chi-\chi_*)G_n da] \quad (4.7c)$$

An alternative form of equation (4.7a) may be obtained by multiplying both sides of this equation by  $\chi_*$  and using the relation  $\phi \equiv k\chi$ ; this yields the following integral equation for the velocity potential  $\phi$ :

$$[(1-w_*)\chi_* - \int_b (\chi-\chi_*)G_n da]\phi_* = \chi_*\psi_* + \int_b (\phi\chi_* - \phi_*\chi)G_n da \quad (4.7d)$$

which thus is a modified form of the original integral equation (4.2). The potential defined by formula (4.7c), which clearly is the exact solution of the modified integral equation (4.7d) if  $\chi$  is proportional to  $\phi$  over the body surface (b), would then seem likely to provide a fairly-good approximation to the exact potential if  $\chi$  is so chosen that  $k \equiv \phi/\chi$  does not vary significantly over (b). An obvious choice for the function  $\chi$  is the potential  $\psi$  defined by formula (4.3). More generally, we may choose  $\chi$  as

$$\chi = \lambda \psi \quad (4.7e)$$

where  $\lambda$  is some (presumably slowly-varying) function which may be chosen so as to render the potential (4.7c) as "good" an approximation as possible [it

may readily be seen from equation (4.7d) that the potential defined by formulas (4.7c) and (4.7e) actually becomes exact if the function  $\lambda$  is proportional to  $\phi/\psi$ ; in the absence of any information, one may simply take  $\lambda \equiv 1$ .

By substituting expression (4.7e) for  $\chi$  into expression (4.7c) for  $\phi_*$ , we thus may obtain

$$\phi_* = \lambda_* \psi_*^2 / [(1-w_*) \lambda_* \psi_* - \int_b (\lambda \psi - \lambda_* \psi_*) G_n] da \quad (4.8)$$

Formula (4.8), where the potential  $\psi$  is defined by formula (4.3) and the free auxiliary function  $\lambda$  may simply be taken as  $\lambda \equiv 1$ , provides an explicit approximation to the velocity potential. This explicit approximation is the simplest result obtained in the above-described theory based on formulating an integral equation for the velocity potential.

Figure 1 - Contours  
of integration in  
the complex plane

$$\lambda \equiv \lambda_r + i\lambda_i$$

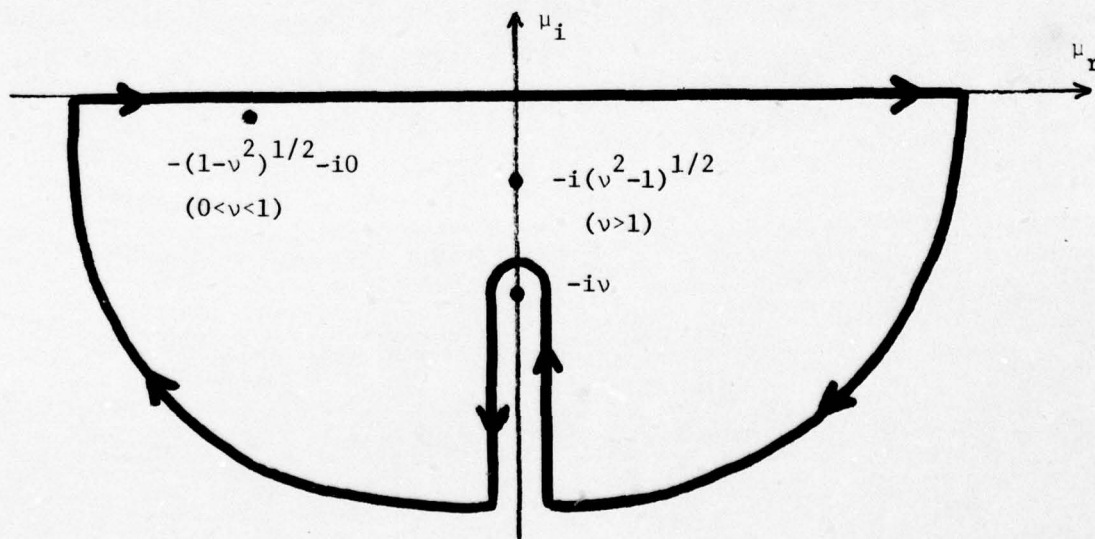
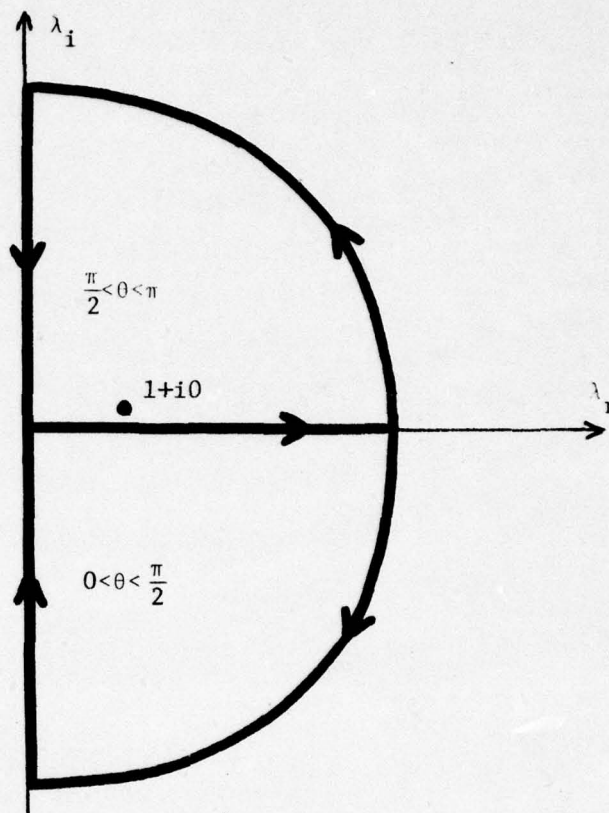

Figure 2 - Contour of integration in the complex plane  $\mu \equiv \mu_r + i\mu_i$

5. The Green function: single-integral representations

It is convenient to introduce the notation  $h \equiv f\rho \equiv f(x'^2 + y'^2)^{1/2}$ ,  
 $v \equiv fz'$ , and  $d \equiv (h^2 + v^2)^{1/2} \equiv fr'$ , so that we have

$$h \equiv f[(x-\xi)^2 + (y-\eta)^2]^{1/2} \equiv \omega^2[(X-X_s)^2 + (Y-Y_s)^2]^{1/2}/g,$$

$$v \equiv f(z+\zeta) \equiv \omega^2(Z+Z_s)/g,$$

$$d \equiv f[(x-\xi)^2 + (y-\eta)^2 + (z+\zeta)^2]^{1/2} \equiv \omega^2[(X-X_s)^2 + (Y-Y_s)^2 + (Z+Z_s)^2]^{1/2}/g,$$

where  $(X, Y, Z)$  and  $(X_s, Y_s, Z_s)$  are the dimensional coordinates of the field point and of the singularity, respectively, in the Green function, and equation (1.5a) was used. It may thus be seen that  $d$  represents the adimensional distance, in terms of  $L = g/\omega^2$  as reference length, between the field point and the mirror image of the singularity with respect to the free-surface plane  $z=0$ , while  $h$  is the horizontal distance (similarly adimensional) between these two points, and  $v$  is the negative of the vertical distance.

We restrict our attention to the limiting case  $\epsilon = +0$  corresponding to purely oscillatory flow. By performing the change of variable  $k = f\lambda$  in the inner integral in expression (2.10b), we can express the Green function  $G(\vec{x}; \vec{\xi}, f)$   $\equiv G(\vec{x}; \vec{\xi}, f, \epsilon=+0)$  in the form

$$\boxed{4\pi G(\vec{x}; \vec{\xi}, f)/f = -1/fr + g(h, v)} \quad (5.1)$$

where the function  $g(h, v)$  is defined by the double integral

$$g(h, v) = -\frac{1}{d} - \frac{2}{\pi} \int_0^\pi d\theta \int_0^\infty d\lambda e^{\frac{(v - ih \cos \theta)\lambda}{\lambda - (1 + i0)}} \quad (5.1a)$$

By performing the changes of variables  $\alpha = f\mu$  and  $\beta = fv$  in expression (2.10a), we may obtain the alternative double-integral representation

$$g(h, v) = \frac{1}{d} - \frac{2}{\pi} \int_0^\infty dv \int_{-\infty}^\infty d\mu e^{\frac{v(\mu^2 + v^2)^{1/2} - ih\mu}{(\mu^2 + v^2)^{1/2} - (1 + i0)}} \quad (5.1b)$$

### 5.1 Haskind's integral representation

We start by expressing the double integral (5.1a) in the form

$$g(h, v) = -1/d - (2/\pi) \int_0^\pi I(\theta; h, v) d\theta, \quad (5.2)$$

where  $I(\theta; h, v)$  is the inner integral given by

$$I(\theta; h, v) = \int_0^\infty \frac{e^{(v-ih\cos\theta)\lambda}}{\lambda-(1+i0)} d\lambda.$$

By considering the contours of integration in the complex plane  $\lambda \equiv \lambda_r + i\lambda_i$  shown in figure 1 — where the lower and upper contours are selected for  $0 < \theta < \pi/2$  and  $\pi/2 < \theta < \pi$ , respectively — we can express the integral  $I$  in the forms

$$I = \int_0^\infty \frac{e^{-(h\cos\theta+iv)t}}{t-i} dt \quad \text{for } 0 < \theta < \pi/2,$$

$$I = \int_0^\infty \frac{e^{(h\cos\theta+iv)t}}{t+i} dt + 2\pi i e^{v-ih\cos\theta} \quad \text{for } \pi/2 < \theta < \pi.$$

Use of the above expressions for  $I$  into equation (5.2) then readily yields

$$g(h, v) = -\frac{1}{d} - \frac{2}{\pi} \int_0^{\pi/2} d\theta \int_0^\infty \frac{e^{-(h\cos\theta+iv)t}}{t-i} dt - \frac{2}{\pi} \int_{\pi/2}^\pi d\theta \int_0^\infty \frac{e^{(h\cos\theta+iv)t}}{t+i} dt - 4ie \int_{\pi/2}^\pi e^{-ih\cos\theta} d\theta.$$

After performing the change of variable  $\theta = \pi - \psi$  in the last two integrals, we may regroup the first two integrals and express the function  $g(h, v)$  in the form

$$g(h, v) = W(h, v) + N(h, v), \quad (5.3)$$

where the functions  $W(h, v)$  and  $N(h, v)$  are defined as

$$W(h, v) = -4ie \int_0^{\pi/2} e^{v \int_0^{\pi/2} ih \cos \theta} d\theta, \quad (5.4)$$

$$N(h, v) = -1/d - (2/\pi) \int_0^{\pi/2} J(\theta; h, v) d\theta,$$

with  $J(\theta; h, v)$  given by

$$J = \int_0^{\infty} \frac{e^{-(h \cos \theta + iv)t}}{t-i} dt + \int_0^{\infty} \frac{e^{-(h \cos \theta - iv)t}}{t+i} dt. \quad (5.4a)$$

The integral  $W(h, v)$  may be expressed in terms of "standard functions", as may be seen for instance from equations (9.1.18) p.360 and (12.1.7) p. 496 in Abramowitz and Stegun [8]. Specifically, we have

$$W(h, v) = 2\pi \exp(v) [\hat{H}_0(h) - iJ_0(h)], \quad (5.5)$$

where  $\hat{H}_0$  and  $J_0$  are the usual Struve and Bessel functions, respectively.

By performing the changes of variables  $\tau = (h \cos \theta + iv)t$  and  $\tau = (h \cos \theta - iv)t$  in the first and second integrals, respectively, in expression (5.4a) for  $J$ , we may obtain

$$J = \int_0^{\infty} \frac{e^{-\tau} d\tau}{\tau + v - ih \cos \theta} + \int_0^{\infty} \frac{e^{-\tau} d\tau}{\tau + v + ih \cos \theta}. \quad (5.6)$$

By grouping these two integrals, we can obtain

$$J = 2 \int_0^{\infty} \frac{e^{-\tau} (\tau + v) d\tau}{(\tau + v)^2 + h^2 \cos^2 \theta}.$$

Use of this expression for J into equation (5.4) then yields

$$N(h, v) = -\frac{1}{d} - \frac{4}{\pi} \int_0^{\infty} d\tau e^{-\tau} (\tau+v) \int_0^{\pi/2} \frac{d\theta}{(\tau+v)^2 + h^2 \cos^2 \theta} ,$$

where an interchange in the order of integration with respect to  $\tau$  and  $\theta$  was performed. The inner integral (with respect to  $\theta$ ) can be evaluated (in the usual manner by transforming this integral into an integral around the unit circle  $|z| = 1$  in the complex plane  $z = e^{i\theta}$ ). We may then obtain

$$N(h, v) = -\frac{1}{d} - 2 \int_0^{\infty} \frac{e^{-\tau} \operatorname{sgn}(\tau+v) d\tau}{[(\tau+v)^2 + h^2]^{1/2}} = -\frac{1}{d} - 2e^v \int_v^{\infty} \frac{e^{-t} \operatorname{sgn} t dt}{(t^2 + h^2)^{1/2}} ,$$

where the change of variable  $t = \tau+v$  was performed. The last expression may readily be written in the following alternative forms:

$$N(h, v) = -\frac{1}{d} - 2e^v \int_0^{\infty} e^{-t} (t^2 + h^2)^{-1/2} dt + 2e^v \int_v^0 e^{-t} (t^2 + h^2)^{-1/2} dt ,$$

$$N(h, v) = -\frac{1}{d} - 4e^v \int_0^{\infty} e^{-t} (t^2 + h^2)^{-1/2} dt + 2e^v \int_v^{\infty} e^{-t} (t^2 + h^2)^{-1/2} dt .$$

The first integrals in the above alternative expressions can be expressed in terms of "standard functions", as may be seen for instance from equation (12.1.8) p. 496 in [8]. We may then obtain

$$N(h, v) = -\frac{1}{d} + \pi e^v [Y_0(h) - \tilde{H}_0(h)] + 2 \int_0^{-v} e^{t+v} (t^2 + h^2)^{-1/2} dt , \quad (5.7a)$$

$$N(h, v) = -\frac{1}{d} + 2\pi e^v [Y_0(h) - \tilde{H}_0(h)] + 2 \int_{-\infty}^{-v} e^{t+v} (t^2 + h^2)^{-1/2} dt , \quad (5.7b)$$

where  $Y_0$  and  $\tilde{H}_0$  are the usual Bessel and Struve functions, respectively, as they are defined in [8] for instance.

By using the above alternative expressions for  $N(h,v)$  and expression (5.5) for  $W(h,v)$  in equation (5.3), we may finally obtain

$$g(h,v) = \pi e^{\frac{v}{d}} [Y_0(h) + \tilde{H}_0(h) - 2iJ_0(h)] - \frac{1}{d} + 2 \int_0^{-v} e^{t+v} (t^2+h^2)^{-1/2} dt, \quad (5.8a)$$

$$g(h,v) = 2\pi e^{\frac{v}{d}} [Y_0(h) - iJ_0(h)] - \frac{1}{d} + 2 \int_{-\infty}^{-v} e^{t+v} (t^2+h^2)^{-1/2} dt. \quad (5.8b)$$

Expression (5.8b) is identical to the expression obtained by Haskind [1] and given in Wehausen and Laitone [9] p. 477 eq. (13.17'). The modified Haskind expression (5.8a) was used by Yeung [10] p. 61 eq. (4.5b), and was also recently rederived by Hearn [11]. For purposes of numerical evaluation, a convenient alternative form of the integral in expression (5.8a) is obtained by performing the change of variable  $\tau = -(t+v)/d$ . This yields

$$g(h,v) = \pi e^{\frac{v}{d}} [Y_0(h) + \tilde{H}_0(h) - 2iJ_0(h)] - \frac{1}{d} + 2 \int_0^{\alpha} e^{-d\tau} (1-2\alpha\tau+\tau^2)^{-1/2} d\tau, \quad (5.8c)$$

where we have  $\alpha \equiv -v/d$  by definition and  $0 \leq \alpha < 1$ . This modified Haskind integral representation is very well suited for evaluating the Green function for small values of  $\alpha$ . Indeed, for  $v=0$ , the integral in formula (5.8c) vanishes, and we have the particularly simple expression

$$g(h,v=0) = \pi [Y_0(h) + \tilde{H}_0(h) - 2iJ_0(h)] - 1/h. \quad (5.9)$$

However, Haskind's integral representation is clearly not well suited for evaluating the Green function for values of  $\alpha$  close to 1. As a matter of fact, expressions (5.8) are not defined for  $\alpha=1$ , i.e. for  $h=0$  and  $v<0$ , so that these expressions can only be used for  $v \leq 0$  and  $h > 0$ . A complementary single-integral representation that is well suited for evaluating the Green function for  $v \leq 0$  and small values of  $h \geq 0$  will now be derived.

### 5.2 The near-field integral representation

By performing the changes of variables  $t=\tau+v-ih\cos\theta$  and  $t=\tau+v+ih\cos\theta$  in the first and second integrals, respectively, in equation (5.6), we may obtain

$$J = \exp(v-ih\cos\theta)E_1(v-ih\cos\theta) + \exp(v+ih\cos\theta)E_1(v+ih\cos\theta) \quad ,$$

where  $E_1$  is the usual exponential integral defined here as in equation (5.1.1) p.228 in [8]. By using the symmetry relation  $E_1(\bar{Z}) = \overline{E_1(Z)}$ , given by equation (5.1.13) p.229 in [8] for instance, we may then obtain  $J = 2\operatorname{Re} \exp(v+ih\cos\theta) E_1(v+ih\cos\theta)$ . Use of this expression for  $J$  into equation (5.4) finally yields

$$N(h,v) = -1/d - (4/\pi) \int_0^{\pi/2} \operatorname{Re} e^Z E_1(Z) d\theta \quad , \quad (5.10)$$

where  $Z$  is the complex number defined as  $Z = v+ih\cos\theta$ .

By using formulas (5.5) and (5.10) in formula (5.3), we then have

$$g(h,v) = 2\pi e^v [\tilde{H}_0^v(h) - iJ_0(h)] - \frac{1}{d} - \frac{4}{\pi} \int_0^{\pi/2} \operatorname{Re} e^Z E_1(Z) d\theta; \quad Z \equiv v+ih\cos\theta \quad . \quad (5.11)$$

For the sake of easy reference (and for reasons which will become clear further on), the expression for the Green function defined by formulas (5.1) and (5.11) is referred to as the "near-field integral representation" of the Green function. This expression has also been obtained, independently and in a different manner, by Martin [2]. The near-field integral representation takes a particularly simple form for  $h=0$ . Indeed, expression (5.11) then becomes

$$g(h=0,v) = 1/v - 2\exp(v) [\operatorname{Re} E_1(v+i0) + i\pi] \quad . \quad (5.12)$$

The main interest of the integral representation (5.10), in comparison to the alternative integral representation (5.7), resides in that this expression can be used to obtain an ascending series useful in the neighborhood of the origin  $h=0=v$ , i.e. for small values of  $h$  and  $-v$ . This ascending series will be given in section 7.

### 5.3. The far-field integral representation

We now start from the double-integral representation (5.1b), which we write in the form

$$g(h, v) = 1/d - (2/\pi) \int_0^{\infty} I(v; h, v) dv, \quad (5.13)$$

where  $I(v; h, v)$  is the inner integral defined as

$$I(v; h, v) = \int_{-\infty}^{\infty} \frac{e^{v(\mu^2+v^2)^{1/2} - ih\mu}}{(\mu^2+v^2)^{1/2} - (1+i0)} d\mu.$$

By multiplying the numerator and denominator of the integrand of the inner integral  $I$  by the expression  $(\mu^2+v^2)^{1/2} + (1+i0)$ , and by rearranging the denominator, we may express this integral in the form

$$I = \int_{-\infty}^{\infty} \frac{e^{v(\mu^2+v^2)^{1/2} - ih\mu} [(\mu^2+v^2)^{1/2} + (1+i0)]}{[\mu + (1-v^2+i0)^{1/2}][\mu - (1-v^2+i0)^{1/2}]} d\mu.$$

The poles  $\pm(1-v^2+i0)^{1/2}$  of the integrand of the above integral are given by  $\pm[(1-v^2)^{1/2} + i0]$  if  $0 < v < 1$  and  $\pm[0 + i(v^2-1)^{1/2}]$  if  $1 < v < \infty$ . By considering the contour of integration in the complex plane  $\mu \equiv \mu_r + i\mu_i$  shown in figure 2, and noting that we have  $(\mu^2+v^2)^{1/2} = \mp i(\mu_i^2-v^2)^{1/2}$  for  $\mu = \pm 0 + i\mu_i$  on the two sides of the cut defined by  $\mu_r = 0$  and  $-\infty < \mu_i < -v$ , we can express the integral  $I$  in the form

$$I = \int_{-\infty}^{-v} \frac{e^{h\mu_i + iv(\mu_i^2-v^2)^{1/2}}}{i(\mu_i^2-v^2)^{1/2} - 1} id\mu_i + \int_{-v}^{-\infty} \frac{e^{h\mu_i - iv(\mu_i^2-v^2)^{1/2}}}{-i(\mu_i^2-v^2)^{1/2} - 1} id\mu_i - 2\pi i R. \quad (5.14)$$

In this expression  $R$  is the residue at the pole  $-(1-v^2)^{1/2}$  if  $0 < v < 1$ , or at  $-i(v^2-1)^{1/2}$  if  $1 < v < \infty$ , so that we have

$$R(v;h,v) = \begin{cases} -\exp[v+ih(1-v^2)^{1/2}]/(1-v^2)^{1/2} & \text{if } 0 < v < 1 \\ i\exp[v-h(v^2-1)^{1/2}]/(v^2-1)^{1/2} & \text{if } 1 < v < \infty \end{cases}, \quad (5.15)$$

as may easily be found. By performing the changes of variables  $t=(\mu^2-v^2)^{1/2}$  and  $t=-(\mu^2-v^2)^{1/2}$  in the first and second integrals, respectively, in expression (5.14), we can finally obtain

$$I(v;h,v) = \int_{-\infty}^{\infty} \frac{e^{-h(t^2+v^2)^{1/2}+ivt}}{(t+i)(t^2+v^2)^{1/2}} t dt - 2\pi i R(v;h,v), \quad (5.16)$$

where  $R$  is given by equations (5.15).

By using equations (5.16) and (5.15) in formula (5.13), we may then express the function  $g(h,v)$  in the form

$$g(h,v) = W'(h,v) + N'(h,v), \quad (5.17)$$

where the functions  $W'$  and  $N'$  are given by

$$W'(h,v) = -4ie^v \int_0^1 \frac{e^{ih(1-v^2)^{1/2}}}{(1-v^2)^{1/2}} dv - 4e^v \int_1^{\infty} \frac{e^{-h(v^2-1)^{1/2}}}{(v^2-1)^{1/2}} dv, \quad (5.17a)$$

$$N'(h,v) = \frac{1}{d} - \frac{2}{\pi} \int_0^{\infty} dv \int_{-\infty}^{\infty} d\mu \frac{e^{-h(\mu^2+v^2)^{1/2}+iv\mu}}{(\mu+i)(\mu^2+v^2)^{1/2}}. \quad (5.17b)$$

The two integrals in equation (5.17a) can be expressed in terms of usual Bessel functions, as may be seen by performing the changes of variables  $v = \sin\theta$  and  $v=(1+t^2)^{1/2}$  in the first and second integrals, respectively, and by using equation (9.1.18) p.360 and equations (12.1.7) and (12.1.8) p.496 in [8]. Specifically, we may obtain

$$W'(h,v) = 2\pi e^v [Y_0(h) - iJ_0(h)] \equiv -2\pi i e^v H_0^{(1)}(h). \quad (5.18)$$

By performing the changes of variables  $\mu = \lambda \cos \theta$  and  $v = \lambda \sin \theta$  in the double integral (5.17b), we may express the function  $N'(h, v)$  in the form

$$N'(h, v) = 1/d - (2/\pi) \int_0^\pi J(\theta; h, v) d\theta \quad , \quad (5.19)$$

where the inner integral  $J$  is given by

$$J(\theta; h, v) = \int_0^\infty \frac{e^{-(h-iv\cos\theta)\lambda}}{\lambda + i\sec\theta} \lambda d\lambda \quad .$$

This integral may be expressed as

$$J = \frac{1}{h-iv\cos\theta} - i\sec\theta \int_0^\infty \frac{e^{-(h-iv\cos\theta)\lambda}}{\lambda + i\sec\theta} d\lambda \quad .$$

By performing the change of variable  $\tau = \lambda + i\sec\theta$ , we may then obtain

$$J = \frac{i\sec\theta}{Z} - i\sec\theta e^Z \int_{i\sec\theta}^\infty \frac{e^{-(h-iv\cos\theta)\tau}}{\tau} \frac{d\tau}{\tau} \quad ,$$

where  $Z$  is the complex number defined as  $Z = v + ih\sec\theta$ . The change of variable  $t = (h-iv\cos\theta)\tau$  then yields

$$J = i\sec\theta \left( \frac{1}{Z} - e^Z \int_Z^\infty \frac{e^{-t}}{t} dt \right) = i\sec\theta [1/Z - e^Z E_1(Z)] \quad .$$

Substitution of this expression for the inner integral  $J$  into formula (5.19) then gives

$$N'(h, v) = -1/d - (4/\pi) \int_0^{\pi/2} \text{Im} e^Z E_1(Z) \sec\theta d\theta \quad , \quad (5.20)$$

as may be found after some transformations.

By substituting expressions (5.18) and (5.20) for  $W'$  and  $N'$ , respectively into formula (5.17), we can finally obtain

$$g(h,v) = 2\pi e^{\frac{v}{d}} [Y_0(h) - iJ_0(h)] - \frac{1}{d} - \frac{4}{\pi} \int_0^{\pi/2} \text{Ime } E_1(Z) \sec\theta d\theta; \quad Z \equiv v + ih \sec\theta \quad (5.21)$$

This expression is obviously not defined for  $h=0$ , and is best suited for evaluating the function  $g(h,v)$  for large values of  $h$ . The expression for the Green function defined by formulas (5.1) and (5.21) will thus be referred to as the "far-field integral representation". This integral representation does not seem to have been given previously, to the author's knowledge. There is a striking similarity in form between the far-field representation (5.21) and the near-field representation (5.11). These two integral representations indeed are complementary. In particular, the near-field representation (5.11) readily provides an asymptotic expansion valid for large values of  $d$  and small or moderate values of  $h/d$ , that is in a sector neighbouring the vertical axis  $h=0$ , while an asymptotic expansion valid for large values of  $d$  and small or moderate values of  $-v/d$ , that is in a sector neighbouring the horizontal axis  $v=0$ , can readily be obtained from the far-field representation (5.21). These complementary asymptotic expansions are given in the following section. Comparison of expressions (5.8b) and (5.21) show that these expressions are equivalent, and that in fact we must have

$$-\frac{2}{\pi} \int_0^{\pi/2} \text{Ime } E_1(v + ih \sec\theta) \sec\theta d\theta \equiv \int_0^{\infty} e^{-d\tau} \left(1 + 2\frac{v}{d}\tau + \tau^2\right)^{-1/2} d\tau, \quad ,$$

as may be obtained by performing the change of variable  $\tau = -(t+v)/d$  in the integral in the Haskind expression (5.8b)

### 6. The Green function: asymptotic expansions

Let us first consider the far-field integral representation defined by expression (5.21), or by the equivalent equations (5.17), (5.18), and (5.20). We define the integral  $I_1(h, v)$  as

$$I_1(h, v) = \text{Im} \left( -\frac{2}{\pi} \right) \int_0^{\pi/2} (1/Z) \sec \theta d\theta; Z \equiv v + ih \sec \theta \quad . \quad (6.1)$$

We have

$$I_1(h, v) = 1/d \quad , \quad (6.1a)$$

as may easily be verified, and indeed was already used in the derivation of expression (5.20). By using equations (6.1) and 6.1a) in equation (5.20), we may express the function  $N'(h, v)$  in the form

$$N'(h, v) = 1/d - (4/\pi) \int_0^{\pi/2} \text{Im} [e^Z E_1(Z) - 1/Z] \sec \theta d\theta; Z \equiv v + ih \sec \theta \quad . \quad (6.2)$$

By using the well-known asymptotic expansion

$$\exp(Z) E_1(Z) - 1/Z \sim \sum_{n \geq 1} (-1)^n n! / Z^{n+1} \quad \text{as } |Z| \rightarrow \infty, \text{ with } |\text{Arg} Z| < \pi \quad , \quad (6.3)$$

in expression (6.2), we may obtain the asymptotic expansion

$$N'(h, v) \sim 1/d + 2 \sum_{n \geq 1} (-1)^n n! I_{n+1}(h, v) \quad \text{as } d \rightarrow \infty, \text{ with } h > 0 \quad , \quad (6.4)$$

where  $I_{n+1}(h, v)$  is the integral defined by

$$I_{n+1}(h, v) = \text{Im} \left( -\frac{2}{\pi} \right) \int_0^{\pi/2} (1/Z^{n+1}) \sec \theta d\theta; Z \equiv v + ih \sec \theta \quad .$$

It may be seen that we have the relation

$$I_{n+1}(h, v) = (-1/n) \partial I_n(h, v) / \partial v, \quad (6.5)$$

from which we may obtain

$$(-1)^n n! I_{n+1}(h, v) = \partial^n I_1(h, v) / \partial v^n = \partial^n (1/d) / \partial v^n, \quad (n \geq 1), \quad (6.5a)$$

where equation (6.1a) was used. The asymptotic expansion (6.4) then becomes

$$H'(h, v) \sim 1/d + 2 \sum_{n \geq 1} \partial^n (1/d) / \partial v^n \quad \text{as } d \rightarrow \infty, \quad \text{with } h > 0. \quad (6.6)$$

It may be verified that we have

$$\partial^n (1/d) / \partial v^n = P_n(\alpha) / d, \quad (6.7)$$

where  $\alpha \equiv -v/d$ , and  $P_n(\alpha)$  is a polynomial of degree  $n$  in  $\alpha$ .

By using equation (5.18) and equations (6.6) and (6.7) in equation (5.17), we may finally obtain

$$g(h, v) \sim 2\pi e^v [Y_0(h) - iJ_0(h)] + 1/d + 2 \sum_{n \geq 1} P_n(\alpha) / d \quad \text{as } d \rightarrow \infty, \quad (6.8)$$

with  $0 \leq \alpha \equiv -v/d < 1$ . The first few polynomials  $P_n(\alpha)$  may be shown to be

$$\begin{array}{l|l} P_1 = \alpha & P_2 = -(1-3\alpha^2) \\ P_3 = -3^2 \alpha (1 - \frac{5}{3} \alpha^2) & P_4 = 3^2 (1 - 10\alpha^2 + \frac{35}{3} \alpha^4) \\ P_5 = 3^3 \cdot 5^2 \alpha (1 - \frac{14}{3} \alpha^2 + \frac{21}{5} \alpha^4) & P_6 = -3^2 \cdot 5^2 (1 - 21\alpha^2 + 63\alpha^4 - \frac{231}{5} \alpha^6) \end{array} \quad (6.8a)$$

We now consider the near-field integral representation defined by expression (5.11), or by the equivalent formulas (5.3), (5.5), and (5.10). We define the integral

$$I_1(h, v) = \operatorname{Re}(-2/\pi) \int_0^{\pi/2} (1/Z) d\theta ; Z \equiv v + ih \cos \theta . \quad (6.9)$$

We have

$$I_1(h, v) = 1/d, \quad (6.9a)$$

as may be verified. By using equations (6.9) and (6.9a) in equation (5.10), we may express the function  $N(h, v)$  in the form

$$N(h, v) = 1/d - (4/\pi) \int_0^{\pi/2} \operatorname{Re} [e^{-Z} E_1(Z) - 1/Z] d\theta ; Z \equiv v + ih \cos \theta . \quad (6.10)$$

By using the asymptotic expansion (6.3) in expression (6.10), we may obtain the asymptotic expansion

$$N(h, v) \sim 1/d + 2 \sum_{n \geq 1} (-1)^n n! I_{n+1}(h, v) \text{ as } d \rightarrow \infty, \text{ with } v < 0, \quad (6.11)$$

where  $I_{n+1}(h, v)$  is the integral

$$I_{n+1}(h, v) = \operatorname{Re}(-2/\pi) \int_0^{\pi/2} (1/Z)^{n+1} d\theta ; Z \equiv v + ih \cos \theta .$$

Equations (6.5) and (6.5a) may readily be verified to hold, so that the asymptotic expansion (6.11) becomes

$$N(h, v) \sim 1/d + 2 \sum_{n \geq 1} \partial^n (1/d) / \partial v^n \text{ as } d \rightarrow \infty, \text{ with } v < 0. \quad (6.12)$$

The functions  $N'(h, v)$  and  $N(h, v)$  defined by equations (6.2) and (6.10) thus happen to have the same asymptotic expansion as  $d \rightarrow \infty$ , although these expansions are not valid in the same regions of the  $(h, v)$  plane. Specifically, the asymptotic expansions (6.6) and (6.12) are not valid in the neighborhoods of the

vertical axis  $h=0$  and of the horizontal axis  $v=0$ , respectively. It may be convenient to express the polynomials  $P_n(\alpha)$  in equation (6.7) as functions of  $\beta \equiv h/d$  [so that we have  $\alpha \equiv (1-\beta^2)^{1/2}$ ]. The polynomials  $P_n(\alpha)$  can then be expressed in the form

$$P_n(\alpha) = n! Q_n(\beta) \quad , \quad (6.13)$$

where the functions  $Q_n(\beta)$  verify  $Q_n(0)=1$ , since we have  $P_n(1)=n!$  as may be verified from equation (6.8a).

By using equation (5.5) and equations (6.12), (6.7), and (6.13) in equation (5.3), we may finally obtain

$$g(h,v) \sim 2\pi e \left[ \overset{v}{\hat{H}}_0(h) - iJ_0(h) \right] + 1/d + 2 \sum_{n \geq 1} n! Q_n(\beta) / d^{n+1} \quad \text{as } d \rightarrow \infty \quad , \quad (6.14)$$

with  $0 < \beta \equiv h/d < 1$ . The first few functions  $Q_n(\beta)$  are given by

$$\begin{array}{l|l} Q_1 = (1-\beta^2)^{1/2} & Q_2 = 1 - \frac{3}{2}\beta^2 \\ Q_3 = (1-\beta^2)^{1/2} \left(1 - \frac{5}{2}\beta^2\right) & Q_4 = 1 - 5\beta^2 + \frac{35}{8}\beta^4 \\ Q_5 = (1-\beta^2)^{1/2} \left(1 - 7\beta^2 + \frac{63}{8}\beta^4\right) & Q_6 = 1 - \frac{21}{2}\beta^2 + \frac{189}{8}\beta^4 - \frac{231}{16}\beta^6 \end{array} \quad (6.14a)$$

The difference,  $\delta g(h,v)$  say, between the values of the function  $g(h,v)$  given by the asymptotic expansions (6.8) and (6.14) is given by

$$\delta g(h,v) = 2\pi e \left[ \overset{v}{Y}_0(h) - \overset{v}{\hat{H}}_0(h) \right] \equiv 2\pi e \frac{-(1-\beta^2)^{1/2} d}{[Y_0(\beta d) - \overset{v}{\hat{H}}_0(\beta d)]} \quad . \quad (6.15)$$

The function  $\delta g(h,v)$  thus is exponentially small as  $d \rightarrow \infty$ , provided we have  $0 < \beta < 1$ . It may then be seen that the "transition discontinuity"  $\delta g(d, \beta = \beta_c)$  due to the use of the asymptotic expansions (6.14) and (6.8) for  $0 < \beta < \beta_c$  and  $\beta_c < \beta < 1$ , respectively, is exponentially small, and thus is negligible—in an asymptotic sense—in comparison with the algebraic terms  $1/d^n$  in the asymptotic expansions. An optimum transition between the asymptotic expansions (6.8) and (6.14) may be

determined from the obvious requirement that the transition discontinuity  $\delta g(d, \beta_t)$  is a minimum. This optimum transition then is given by the solution of the equation  $\partial[\delta g(d, \beta)]/\partial \beta = 0$ . By differentiating equation (6.15), we may then obtain the following equation for the "transition curve"  $v_t(h)$

$$-v_t = h[\tilde{H}_0(h) - Y_0(h)] / [\tilde{H}_1(h) - Y_1(h) - 2/\pi] \quad , \quad (6.16)$$

where equations (9.1.28) p. 361 and (12.1.11) p. 496 in [8] were used. In particular, equation (6.16) gives

$$-v_t \sim h^2 (1 + 2/h - 30/h^2 + \dots) \text{ as } h \rightarrow \infty \quad , \quad (6.16a)$$

as may be obtained by using equations (12.1.30) and (12.1.31) p. 497 in [8]. By substituting expression (6.16a) into equation (6.15) we may then obtain the following expression for the transition discontinuity  $\delta g_t(h) \sim -4\exp(-h^2)/h$  as  $h \rightarrow \infty$ . The discontinuity may be regarded as negligible in practice if it is sufficiently small in comparison with the main algebraic term, i.e.  $1/d$ , in the asymptotic expansions (6.8) and (6.14). We thus require that  $4d\exp(-h^2)/h$  be smaller than the desired relative accuracy,  $\epsilon$  say, which might be taken as  $\epsilon = .01$  for practical applications. This then yields  $4(1+h^2)^{1/2}\exp(-h^2) < .01$  [since we have  $d \equiv (h^2 + v^2)^{1/2} \sim h(1+h^2)^{1/2}$  as  $h \rightarrow \infty$  on the transition curve  $-v \sim h^2$ ], from which we may obtain  $h > 2.6$  and  $d > 7.2$ .

For sufficiently large values of  $d$  (say for  $d$  greater than about 7 according to the foregoing analysis), the function  $g(h, v)$  can then be evaluated by means of the asymptotic expression

$$g(h, v) \sim W(h, v) + N(h, v) \text{ as } d \rightarrow \infty \quad . \quad (6.17)$$

The function  $W(h, v)$  in expression (6.17) is given by

$$W(h, v) = \begin{cases} 2\pi \exp(v) [Y_0(h) - iJ_0(h)] & v_t(h) < v < 0 \\ 2\pi \exp(v) [\tilde{H}_0(h) - iJ_0(h)] & -\infty < v < v_t(h) \end{cases} \quad , \quad (6.17a)$$

where the transition curve  $v_t(h)$  is defined by equation (6.16). The function  $N(h,v)$  in expression (6.17) can be evaluated by means of either one of the equivalent asymptotic expansions

$$N(h,v) \sim 1/d + 2 \sum_{n>1} P_n(\alpha)/d^{n+1} \equiv 1/d + 2 \sum_{n>1} n! Q_n(\beta)/d^{n+1} \quad \text{as } d \rightarrow \infty, \quad (6.17b)$$

where  $\alpha \equiv -v/d$  and  $\beta \equiv h/d$ , and the functions  $P_n(\alpha)$  and  $Q_n(\beta)$  are given by equations (6.8a) and (6.14a).

The error associated with the use of the asymptotic expansion (6.17b) is of the order of the term following the last term in the truncated series (i.e. the first discarded term in the series), as is well known. The requirement that the function  $N(h,v)$  be evaluated with a relative accuracy  $\epsilon$  (say with  $\epsilon = .01$  in practice) may then be approximately expressed by the condition  $2|P_n(\alpha)|/d^n < \epsilon$ , which yields  $d > [2|P_n(\alpha)|/\epsilon]^{1/n}$ . The function  $d_n(\alpha; \epsilon) \equiv [2|P_n(\alpha)|/\epsilon]^{1/n}$  may be evaluated, notably in the particular cases  $\alpha=0$  and  $\alpha=1$ . In the particular case  $\alpha=1(\beta=0)$ , that is along the vertical axis  $h=0$ , we have  $P_n(1)=n!$ , so that we may obtain  $d_n(\alpha=1, \epsilon) = (2n!/\epsilon)^{1/n}$ . For  $\epsilon=.01$ , we may then obtain  $d_1=200$ ,  $d_2=20$ ,  $d_3=10.63$ ,  $d_4=8.32$ ,  $d_5=7.52$ ,  $d_6=7.24$ ,  $d_7=7.21$ ,  $d_8=7.30, \dots$  In the particular case  $\alpha=0(\beta=1)$ , that is along the horizontal axis  $v=0$ , we have  $P_{2n-1}(0)=0$  and  $|P_{2n}(0)| = 1^2 \cdot 3^2 \cdot 5^2 \dots (2n-1)^2$ , as may be seen from equations (6.8a). We may then obtain  $d_{2n}(\alpha=0, \epsilon) = [2 \cdot 1^2 \cdot 3^2 \cdot 5^2 \dots (2n-1)^2 / \epsilon]^{1/2n}$ . For  $\epsilon=.01$ , this yields  $d_2=14.14$ ,  $d_4=6.51$ ,  $d_6=5.96$ ,  $d_8=6.21, \dots$  The above results suggest that if a relative accuracy  $\epsilon=.01$  is desired (as ought to be sufficient for most practical applications), it may not be advantageous to use more than the first five terms, i.e.  $1 \leq n \leq 4$ , in the asymptotic expansion (6.17b); furthermore, it appears that this 5-terms asymptotic expansion could be used for  $d$  greater than about 8 if  $\alpha=1(h=0)$  and for  $d$  greater than about 6.5 if  $\alpha=0(v=0)$ . These values of  $d$  fortunately happen to be about the same as the value  $d=7.2$  found previously from the requirement that the transition discontinuity in the value of the function  $W(h,v)$  be negligible. On the basis of the foregoing analysis, it may thus be recommended that the 5-terms asymptotic expansion (6.17b) be used in a region which may approximately (and tentatively) be defined by the equation  $h^2/45 + v^2/65 \geq 1$ ; a more precise numerical determination of the domain of practical usefulness of the asymptotic expansion (6.17b) is of course possible.

### 7. The Green function: ascending series

In this section, an ascending series for the function  $g(h, v)$  is obtained from the near-field representation given by formula (5.11), or by the equivalent equations (5.3), (5.5) and (5.10). Let the integrand  $\exp(Z)E_1(Z)$  in equation (5.10) be expressed in the form

$$e E_1(Z) = -e^{(\ln Z + \gamma) + Z} [E_1(Z) + \ln Z + \gamma] \quad (7.1)$$

Furthermore, let the complex number  $Z \equiv v + ih \cos \theta$  in the term  $\ln Z$  be written in the form

$$Z = \frac{d-v}{2} \left( \frac{2v}{d-v} + i \frac{2h}{d-v} \cos \theta \right) \quad (7.2)$$

for reasons that will become clear further on. Also, let the parameter  $\sigma$  be defined as

$$\sigma \equiv h/(d-v) \quad (7.3)$$

It may be verified that we have  $0 < \sigma < 1$ , and  $2v/(d-v) = \sigma^2 - 1$ , so that equation (7.2) becomes

$$Z = \frac{d-v}{2} (\sigma^2 - 1 + i 2\sigma \cos \theta) \quad .$$

Use of this expression for  $Z$  in equation (7.1) then yields

$$e E_1(Z) = -e^{v + ih \cos \theta} \left[ \ln \frac{d-v}{2} + \gamma + \ln(\sigma^2 - 1 + i 2\sigma \cos \theta) \right] + e^Z [E_1(Z) + \ln Z + \gamma] \quad .$$

By using this expression for the integrand  $\exp(Z)E_1(Z)$  in equation (5.10), we may express the function  $N(h, v)$  in the form

$$N(h, v) = -\frac{1}{d} + 2e^v \left( \ln \frac{d-v}{2} + \gamma \right) J_0(h) + 2e^v I - 2J \quad (7.4)$$

where equation (9.1.18) p. 360 in [8] was used, and I and J are the integrals defined as

$$I = (2/\pi) \operatorname{Re} \int_0^{\pi/2} e^{ih \cos \theta} \ln[-(1-\sigma) + i2\sigma \cos \theta] d\theta, \quad (7.5)$$

$$J = (2/\pi) \int_0^{\pi/2} \operatorname{Re} e^Z [E_1(Z) + \ln Z + \gamma] d\theta; \quad Z \equiv v + ih \cos \theta. \quad (7.6)$$

Substitution of expressions (5.5) and (7.4) for the functions W and N into equation (5.3) finally yields the expression

$$g(h, v) = -1/d + 2e^v [\pi \hat{H}_0^v(h) + (\ln \frac{d-v}{2} + \gamma - i\pi) J_0(h) + I] - 2J. \quad (7.7)$$

The ascending series for the above-defined integrals I and J are given below. The integral J is considered first.

We have

$$e^Z [E_1(Z) + \ln Z + \gamma] = \left[ \sum_{m=0}^{\infty} \frac{Z^m}{m!} \right] \left[ \sum_{k=1}^{\infty} \frac{(-1)^{k+1} Z^k}{k \cdot k!} \right],$$

as readily follows from the ascending series of the functions  $\exp(Z)$  and  $E_1(Z)$ . The above product of series may be expressed in the form

$$\sum_{n=1}^{\infty} \left[ \sum_{k=1}^n \frac{(-1)^{k+1}}{k} \frac{n!}{(n-k)!k!} \right] \frac{Z^n}{n!} = \sum_{n=1}^{\infty} \left( \sum_{k=1}^n \frac{1}{k} \right) \frac{Z^n}{n!},$$

where equation (0.155,4) p.4 in Gradshteyn and Ryzhik [12] was used. The well-known binomial expansion formula yields

$$Z \equiv (v + ih \cos \theta)^n = \sum_{k=0}^n \binom{n}{k} i^k h^k v^{n-k} \cos^k \theta.$$

We may then obtain

$$\operatorname{Re} Z = n! \sum_{k=0}^{n'} (-1)^k h^v \cos^{2k} \theta / (2k)! (n-2k)! ,$$

where  $n'$  is defined as  $n' = n/2$  if  $n$  is even or as  $n' = (n-1)/2$  if  $n$  is odd.

We thus have

$$\operatorname{Re} [E_1(Z) + \ell n Z + \gamma] = \sum_{n=1}^{\infty} \left( \sum_{m=1}^n \frac{1}{m} \right) \left[ \sum_{k=0}^{n'} (-1)^k \frac{h^v}{(2k)! (n-2k)!} \cos^{2k} \theta \right] .$$

Substitution of this series for the integrand in the integral (7.6) and term by term integration finally yields

$$J = v + \sum_{n=2}^{\infty} \left( \sum_{m=1}^n \frac{1}{m} \right) (v/n)! \sum_{k=1}^{n'} (-1)^k \frac{1 \cdot 3 \cdot 5 \dots (2k-1)}{2 \cdot 4 \cdot 6 \dots (2k)} \frac{h^v}{(2k)! (n-2k)!} \cos^{2k} \theta ; n' = \begin{cases} n/2 \\ (n-1)/2 \end{cases} . \quad (7.8)$$

We now consider the integral  $I$ . By replacing the function  $\exp(ih \cos \theta)$  in equation (7.5) by the ascending series  $\sum_{n=0}^{\infty} i^n h^n \cos^n \theta / n!$ , we may obtain

$$I = \sum_{n=0}^{\infty} (-1)^n \left[ \frac{h^{2n}}{(2n)!} \operatorname{Re} I_{2n} - \frac{h^{2n+1}}{(2n+1)!} \operatorname{Im} I_{2n+1} \right] , \quad (7.9)$$

where  $I_n$  is the integral defined by

$$I_n = (2/\pi) \int_0^{\pi/2} \ell n [-(1-\sigma^2) + i2\sigma \cos \theta] \cos^n \theta d\theta .$$

It may be verified that we have

$$\operatorname{Re} I_{2n} = I'_{2n} \quad \text{and} \quad \operatorname{Im} I_{2n+1} = -i I'_{2n+1} , \quad (7.10)$$

where  $I'_n$  is the integral given by

$$I'_n = (1/2\pi) \int_{-\pi}^{\pi} \ell n [-(1-\sigma^2) + i2\sigma \cos \theta] \cos^n \theta d\theta .$$

Use of equations (7.10) in equation (7.9) then yields

$$I = I'_0 + \sum_{n=1}^{\infty} (-1)^n \left[ \frac{h}{(2n)!} I'_{2n} + i \frac{h}{(2n-1)!} I'_{2n-1} \right] \quad (7.11)$$

The integral  $I'_n$  can be expressed as a contour integral around the unit circle  $|z| = 1$  in the complex plane  $z = \exp(i\theta)$ . We thus have

$$i2^n I'_n = \frac{1}{2\pi} \int_{|z|=1} \ln \left[ \frac{i\sigma}{z} \left( z + \frac{i}{\sigma} \right) (z - i\sigma) \right] \left( z + \frac{1}{z} \right)^n \frac{dz}{z} \quad (7.12)$$

By using the binomial theorem, and after some transformations, we may obtain

$$\frac{1}{z} \left( z + \frac{1}{z} \right)^{2n} = \sum_{k=0}^{n-1} \binom{2n}{k} z^{2n-2k-1} + \frac{1}{z^{2n-2k+1}} + \binom{2n}{n} \frac{1}{z} \quad (7.13a)$$

$$\frac{1}{z} \left( z + \frac{1}{z} \right)^{2n-1} = \sum_{k=0}^{n-1} \binom{2n-1}{k} \left( z^{2n-2k-2} + \frac{1}{z^{2n-2k}} \right) \quad (7.13b)$$

Use of equations (7.13a,b) in equation (7.12) then yields

$$i2^{2n} I'_{2n} = i \binom{2n}{n} I'_0 + \sum_{k=0}^{n-1} \binom{2n}{k} (I_{2n-2k-1}^+ + I_{2n-2k+1}^-) \quad (7.14a)$$

$$i2^{2n-1} I'_{2n-1} = \sum_{k=0}^{n-1} \binom{2n-1}{k} (I_{2n-2k-2}^+ + I_{2n-2k}^-) \quad (7.14b)$$

where  $I_m^+$  and  $I_m^-$  are the integrals defined by

$$I_m^+ = \frac{1}{2\pi} \int_{|z|=1} \ln \left[ \frac{i\sigma}{z} \left( z + \frac{i}{\sigma} \right) (z - i\sigma) \right] z^m dz, \quad m \geq 0 \quad (7.15a)$$

$$I_m^- = \frac{1}{2\pi} \int_{|z|=1} \ln\left[\frac{i\sigma}{z} \left(z + \frac{i}{\sigma}\right) (z - i\sigma)\right] \frac{dz}{z^m}, \quad m \geq 2. \quad (7.15b)$$

It may be verified that we have

$$I_0' = 0. \quad (7.16)$$

Furthermore, we have

$$I_m^- = I_{m-2}^+, \quad (7.17)$$

as may easily be verified by performing the change of variable  $z=1/\zeta$  in the integral (7.15b). Use of equations (7.16) and (7.17) in equations (7.14a,b) then yields

$$i^{2n-1} I_{2n}' = \sum_{k=0}^{n-1} \binom{2n}{k} I_{2n-2k-1}^+, \quad (7.18a)$$

$$i^{2n-2} I_{2n-1}' = \sum_{k=0}^{n-1} \binom{2n-1}{k} I_{2n-2k-2}^+. \quad (7.18b)$$

We have  $0 < \sigma < 1$ , so that the function  $\ln[i\sigma(z+i/\sigma)]z^m$  is holomorphic in the region  $|z| < 1$ , and the integral (7.15a) becomes

$$I_m^+ = \frac{1}{2\pi} \int_{|z|=1} \ln\left(\frac{z-i\sigma}{z}\right) z^m dz. \quad (7.19)$$

This integral can easily be evaluated; we have

$$I_m^+ = i \sigma^{m+1} / (m+1). \quad (7.20)$$

Use of expression (7.20) for the integral  $I_m^+$  in equations (7.18a,b) then gives

$$(-1)^n I'_{2n} / (2n)! = (-2/2) \sum_{k=0}^{2n} (-1)^k \sigma^{2n-2k} / (2n-2k)k!(2n-k)! \quad , \quad (7.21a)$$

$$i(-1)^n I'_{2n-1} / (2n-1)! = (-2/2) \sum_{k=0}^{2n-1} (-1)^k \sigma^{2n-1-2k} / (2n-1-2k)k!(2n-1-k)! \quad . \quad (7.21b)$$

By substituting expressions (7.16) and (7.21a,b) for the integrals  $I'_0$ ,  $I'_{2n}$  and  $I'_{2n-1}$  in equation (7.11), we may finally obtain

$$I = -2 \sum_{n=1}^{\infty} \left( \sum_{k=0}^{n'} \frac{(-1)^k \sigma^{n-2k}}{k!(n-k)!} \right) \left( \frac{h}{2} \right)^n ; \quad \sigma \equiv \frac{h}{d-v} , \quad n' = \begin{cases} n/2-1 \\ (n-1)/2 \end{cases} \quad . \quad (7.22)$$

Equations (7.22), (7.8), and (7.7) - where the classical ascending series for the Bessel and Struve functions  $J_0(h)$  and  $\tilde{H}_0(h)$ , namely

$$J_0(h) = \sum_{n=0}^{\infty} (-1)^n \left( \frac{h}{4} \right)^{2n} / (n!)^2 , \quad \frac{\pi}{2} \tilde{H}_0(h) = \sum_{n=0}^{\infty} (-1)^n h^{2n+1} / 1^2 \cdot 3^2 \cdot 5^2 \dots (2n+1)^2 , \quad (7.23a,b)$$

may evidently be used - provide an ascending series useful for evaluating the function  $g(h,v)$  for small and moderate values of  $d$ .

### 8. The Green function: one-dimensional Taylor series expansions

The near-field representation (5.11) may be used to obtain a Taylor series expansion of the function  $g(h,v)$  in the neighborhood of the vertical axis  $h=0$ . Let  $I(h,v)$  be the function defined as

$$I(h,v) = \operatorname{Re}(4/\pi) \int_0^{\pi/2} e^{Z} E_1(Z) d\theta; \quad Z \equiv v + ih \cos \theta. \quad (8.1)$$

By expanding the function  $I(h,v)$  in a Taylor series about the axis  $h=0$ , we may obtain

$$I(h,v) = \sum_{n=0}^{\infty} h^n \left[ \frac{\partial^n I(h,v)}{\partial h^n} \right]_{h=0} / n!. \quad (8.2)$$

Differentiation of both sides of equation (8.1) yields

$$\frac{\partial^n I(h,v)}{\partial h^n} = \operatorname{Re}(4/\pi) \int_0^{\pi/2} \left[ \frac{d^n e^Z E_1(Z)}{dZ^n} \right] i^n \cos^n \theta d\theta. \quad (8.3)$$

From the definition of the exponential integral function  $E_1(Z)$ , given for instance by equation (5.1.1) p. 228 in [8], it may be verified that we have

$$\frac{d^n e^Z E_1(Z)}{dZ^n} = e^Z E_1(Z) + \sum_{k=1}^n (k-1)! / (-Z)^k \quad \text{for } n \geq 1. \quad (8.4)$$

By using equation (8.4) in equation (8.3), we may obtain

$$\left. \frac{\partial^{2n} I}{\partial h^{2n}} \right|_{h=0} = 2(-1)^n \frac{1 \cdot 3 \cdot 5 \dots (2n-1)}{2 \cdot 4 \cdot 6 \dots (2n)} e^v \operatorname{Re} E_1(v+i0) + \sum_{k=1}^{2n} \frac{(k-1)!}{(-v)^k} \quad \text{for } n \geq 1, \quad (8.5a)$$

while for  $n=0$  we have

$$I(h=0,v) = 2e^v \operatorname{Re} E_1(v+i0). \quad (8.5b)$$

We have  $\operatorname{Re}iE_1(v+i0) = -\operatorname{Im}E_1(v+i0) = \pi$ , as may be found from the ascending series for the exponential integral given, for instance, by equation (5.1.11) p. 229 in [8]. It may then be seen that we have

$$\left. \frac{\partial I}{\partial h} \right|_{h=0} = 4e^v, \quad (8.5c)$$

and

$$\left. \frac{\partial^{2n+1} I}{\partial h^{2n+1}} \right|_{h=0} = 4(-1)^n \frac{2 \cdot 4 \cdot 6 \dots (2n)}{3 \cdot 5 \cdot 7 \dots (2n+1)} e^v \quad \text{for } n \geq 1. \quad (8.5d)$$

Use of equations (8.5a,b,c,d) in the series (8.2) then yields

$$\begin{aligned} I(h,v) = & 2e^v \operatorname{Re}E_1(v+i0) \left[ 1 + \sum_{n=1}^{\infty} (-1)^n \frac{1 \cdot 3 \cdot 5 \dots (2n-1)}{2 \cdot 4 \cdot 6 \dots (2n)} \frac{h^{2n}}{(2n)!} \right] + 2J(h,v) + \\ & + 4e^v \left[ h + \sum_{n=1}^{\infty} (-1)^n \frac{2 \cdot 4 \cdot 6 \dots (2n)}{3 \cdot 5 \cdot 7 \dots (2n+1)} \frac{h^{2n+1}}{(2n+1)!} \right], \quad (8.6) \end{aligned}$$

where the function  $J(h,v)$  is defined by the series

$$J(h,v) = \sum_{n=1}^{\infty} (-1)^n \left[ \sum_{k=1}^{2n} \frac{(k-1)!}{(-v)^k} \right] \frac{1 \cdot 3 \cdot 5 \dots (2n-1)}{2 \cdot 4 \cdot 6 \dots (2n)} \frac{h^{2n}}{(2n)!}. \quad (8.6a)$$

The two series between brackets in equation (8.6) are the ascending series for the functions  $J_0(h)$  and  $(\pi/2)\tilde{H}_0^v(h)$ , respectively, as may readily be verified from equations (7.23a,b), so that equation (8.6) becomes

$$I(h,v) = 2e^v \left[ \operatorname{Re}E_1(v+i0)J_0(h) + \pi\tilde{H}_0^v(h) \right] + 2J(h,v). \quad (8.7)$$

The series (8.6a) for the function  $J(h,v)$  may be expressed in the form

$$J(h, v) = \sum_{n=1}^{\infty} (-1)^n \left[ \sum_{m=0}^{2n-1} \frac{(2n-1-m)!}{(-v)^{2n-m}} \right] \frac{1.3.5\dots(2n-1)}{2.4.6\dots(2n)} \frac{h^{2n}}{(2n)!} \quad (8.7a)$$

By substituting expression (8.7) for the integral (8.1) into formula (5.11), we may finally express the function  $g(h, v)$  in the form

$$g(h, v) = -1/d - 2J_0(h) \exp(v) [\operatorname{Re} E_1(v+i0) + i\pi] - 2J(h, v) \quad (8.8)$$

The series (8.7a) for the function  $J(h, v)$  can be written in the form

$$J(h, v) = \sum_{n=1}^{\infty} \frac{(-1)^n}{2^n} \frac{1.3.5\dots(2n-1)}{2.4.6\dots(2n)} \left(\frac{h}{-v}\right)^{2n} P_n(v) \quad (8.8a)$$

where  $P_n(v)$  is the polynomial of degree  $2n-1$  given by

$$P_n(v) = 1 + \sum_{m=1}^{2n-1} (-v)^m / ((2n-1)(2n-2)(2n-3)\dots(2n-m)) \quad (8.8b)$$

We have  $J(h=0, v) = 0$  and  $J_0(h=0) = 1$ , so that expression (8.8) becomes identical to expression (5.12) in the limit  $h=0$ .

A complementary Taylor series of the function  $g(h, v)$  in the neighborhood of the horizontal axis  $v=0$  can be obtained from the Haskind integral representation (5.8a). Let  $I(h, v)$  be the function defined as

$$I(h, v) = \int_0^{-v} e^{t+v} (t^2+h^2)^{-1/2} dt \quad (8.9)$$

Expansion of this function in a Taylor series about the axis  $v=0$  yields

$$I(h, v) = \sum_{n=1}^{\infty} v^n \left[ \partial^n I(h, v) / \partial v^n \right]_{v=0} / n! \quad (8.10)$$

where the fact that  $I(h, v=0) = 0$  was used. It can be verified that we have

$$\left. \frac{\partial^{2n+1} I}{\partial v^{2n+1}} \right|_{v=0} = \sum_{k=0}^n (-1)^{k+1} \frac{1 \cdot 3 \cdot 5 \dots (2k-1)}{h^{2k+1}} = \left. \frac{\partial^{2n+2} I}{\partial v^{2n+2}} \right|_{v=0} \quad \text{for } n > 0. \quad (8.11)$$

Use of equation (8.11) in equation (8.10) yields the series

$$I(h, v) = \sum_{n=0}^{\infty} \frac{v^{2n+1}}{(2n+1)!} \left(1 + \frac{v}{2n+2}\right) \left[ \sum_{k=0}^n (-1)^{k+1} \frac{1 \cdot 3 \cdot 5 \dots (2k-1)}{h^{2k+1}} \right],$$

which may be written in the equivalent form

$$I(h, v) = \sum_{n=0}^{\infty} \frac{(-v)^{2n+1}}{(2n+1)!} \left(1 + \frac{v}{2n+2}\right) \left[ \sum_{m=0}^n (-1)^{n-m} \frac{1 \cdot 3 \cdot 5 \dots (2n-1-2m)}{h^{2n+1-2m}} \right]. \quad (8.12)$$

By using equation (8.9) in equation (5.8), we may then express the function  $g(h, v)$  in the form

$$g(h, v) = -1/d + \pi \exp(v) [Y_0(h) + \tilde{H}_0(h) - 2iJ_0(h)] + 2I(h, v) \quad (8.13)$$

The series (8.12) for the function  $I(h, v)$  may be written as

$$I(h, v) = \frac{-v}{h} \left(1 + \frac{v}{2}\right) + \sum_{n=1}^{\infty} \frac{(-1)^n}{2n+1} \frac{1 \cdot 3 \cdot 5 \dots (2n-1)}{2 \cdot 4 \cdot 6 \dots (2n)} \left(\frac{-v}{h}\right)^{2n+1} \left(1 + \frac{v}{2n+2}\right) P_n(h), \quad (8.13a)$$

where  $P_n(h)$  is the polynomial of degree  $2n$  given by

$$P_n(h) = 1 + \sum_{m=1}^n (-1)^m \frac{h^{2m}}{(2n-1)(2n-3)(2n-5) \dots (2n+1-2m)} \quad (8.13b)$$

In the limit  $v=0$ , we have  $I=0$ , and expression (8.13) becomes identical to expression (5.9).

### 9. The gradient of the Green function

The vertical derivative,  $G_z$ , of the Green function  $G(\vec{x}; \vec{\xi}, f)$  may be expressed directly in terms of the function  $g(h, v)$ , as will now be shown. Following an idea used by Eggers [4] for the similar problem of ship wave resistance, we express the Green function in the alternative forms

$$4\pi G(\vec{x}; \vec{\xi}, f) = -1/r + 1/r' + H^+(\rho, z'; f) = -1/r - 1/r' + H^-(\rho, z'; f) \quad , \quad (9.1a, b)$$

where we have  $\rho \equiv [(x-\xi)^2 + (y-\eta)^2]^{1/2}$ ,  $z' \equiv z + \zeta$ ,  $r \equiv [\rho^2 + (z-\zeta)^2]^{1/2}$ ,  $r' \equiv (\rho^2 + z'^2)^{1/2}$ , and  $f \equiv \omega^2 L/g$ , as was defined previously. Although the precise expressions for the function  $H^+(\rho, z'; f)$  and  $H^-(\rho, z'; f)$  can evidently be readily obtained from the analysis in the previous sections, for instance by setting  $\epsilon = +0$  in expressions (2.10a) and (2.10b), the precise forms of these functions is actually not required here. By using equations (9.1a, b), we may obtain

$$4\pi(G_z - fG) = (-1/r - 1/r')_z + H_z^- - f(-1/r + 1/r') - fH^+ \quad . \quad (9.2)$$

The free-surface condition (2.13b) shows that we have  $G_z - fG = 0$  on  $z=0$  if  $\zeta < 0$ . It may also readily be seen that  $-1/r + 1/r' = 0$  on  $z=0$  and  $(1/r + 1/r')_z = 0$  on  $z=0$  if  $\zeta < 0$ . It then follows from equation (9.2) that we have  $H_z^- - fH^+ = 0$  on  $z=0$  if  $\zeta < 0$ . This relation however must hold for  $z \leq 0$  since the functions  $H^+$  and  $H^-$  depend on  $z + \zeta$ . We thus have  $H_z^- - fH^+ \equiv 0$ , as may also readily be verified from equations (2.9a) and (2.9b). Equation (9.2) then becomes

$$4\pi(G_z - fG) = -(1/r + 1/r')_z + f(1/r - 1/r') \quad . \quad (9.3)$$

By using expression (5.1) for the Green function, that is

$$4\pi G(\vec{x}; \vec{\xi}, f) / f = -1/fr + g(h, v) \quad (9.4)$$

in equation (9.3), we may finally obtain

$$4\pi G_z / f^2 = (z - \zeta) / f^2 r^3 + v/d^3 - 1/d + g(h, v) \quad , \quad (9.5)$$

where  $v \equiv fz'$ ,  $h \equiv f\rho$ , and  $d \equiv fr'$ , as was defined previously. Expression (9.5)

for the vertical derivative  $G_z$  of the Green function was obtained previously by Martin [2], in a different manner. The horizontal derivatives  $G_x$  and  $G_y$  of the Green function  $G$  may readily be obtained by differentiating expression (9.4). Specifically, we may obtain

$$\boxed{G_x = G_\rho(x-\xi)/\rho, G_y = G_\rho(y-\eta)/\rho}, \quad (9.6a,b)$$

with  $G_\rho \equiv \partial G/\partial \rho$  given by

$$\boxed{4\pi G_\rho / f^2 = \rho / f^2 r^3 + g_h(h,v)}. \quad (9.7)$$

References

1. Haskind, M.D., "On Wave Motions on a Heavy Fluid", Prikl. Mat. Mekh., Vol. 18, pp. 15-26, 1954.
2. Martin, D., Private Communications, January and June 1978.
3. Noblesse, F., "Alternative Expressions for the Green Function of the Theory of Ship Wave Resistance", Massachusetts Institute of Technology Sea Grant College Program, Report MITSG 79-23, 41 pp., September 1979.
4. Eggers, K.W.H., Proceedings International Seminar on Wave Resistance, p. 399, Tokyo, 1976.
5. Stoker, J. J., "Water Waves", Interscience Publ., New York, 567 pp., 1957.
6. Lighthill, M.J., "On Waves Generated in Dispersive Systems by Travelling Forcing Effects, with Applications to the Dynamics of Rotating Fluids", Journal of Fluid Mechanics, Vol. 27, Part 4, pp. 725-752, 1967.
7. Newman, J.N., "Marine Hydrodynamics", MIT Press, Cambridge, Mass., 402 pp., 1977.
8. Abramovitz, M., and Stegun, I.A., "Handbook of Mathematical Functions", Dover Publ., New York, 1046 pp., 1965.
9. Wehausen, J.V., and Laitone, E.V., "Surface Waves", Encyclopedia of Physics, Springer-Verlag, Berlin, Vol. IX, pp. 446-778, 1960.
10. Yeung, R.W., "A Singularity-Distribution Method for Free-Surface Flow Problems with an Oscillating Body", University of California, Berkeley, Report NA 73-6, 124 pp., 1973.
11. Hearn, G.E., "Alternative Methods of Evaluating Green's Function in Three-Dimensional Ship-Wave Problems", Journal of Ship Research, Vol. 21, No. 2, pp. 89-93, June 1977.
12. Gradshteyn, I.S. and Ryzhik, I.W., "Tables of Integrals, Series, and Products", Academic Press, New York, 1086 pp., 1965.

DISTRIBUTION LIST FOR UNCLASSIFIED  
TECHNICAL REPORTS AND REPRINTS ISSUED UNDER  
CONTRACT N00014-78-C-0169 TASK NR 062-525

Defense Technical Information Center  
Cameron Station  
Alexandria, VA 22314 (12 copies)

Professor Bruce Johnson  
U.S. Naval Academy  
Engineering Department  
Annapolis, MD 21402

Library  
U.S. Naval Academy  
Annapolis, MD 21402

Technical Library  
David W. Taylor Naval Ship Research  
and Development Center  
Annapolis Laboratory  
Annapolis, MD 21402

Professor C. S. Yih  
The University of Michigan  
Department of Engineering Mechanics  
Ann Arbor, MI 48109

Professor T. Francis Ogilvie  
The University of Michigan  
Department of Naval Architecture  
and Marine Engineering  
Ann Arbor, MI 48109

Office of Naval Research  
Code 211  
800 N. Quincy Street  
Arlington, VA 22217

Office of Naval Research  
Code 438  
800 N. Quincy Street  
Arlington, VA 22217 (3 copies)

Office of Naval Research  
Code 473  
800 N. Quincy Street  
Arlington, VA 22217

NASA Scientific and Technical  
Information Facility  
P. O. Box 8757  
Baltimore/Washington International  
Airport  
Maryland 21240

Professor Paul M. Naghdi  
University of California  
Department of Mechanical Engineering  
Berkeley, CA 94720

Librarian  
University of California  
Department of Naval Architecture  
Berkeley, CA 94720

Professor John V. Wehausen  
University of California  
Department of Naval Architecture  
Berkeley, CA 94720

Library  
David W. Taylor Naval Ship Research  
and Development Center  
Code 522.1  
Bethesda, MD 20084

Mr. Justin H. McCarthy, Jr.  
David W. Taylor Naval Ship Research  
and Development Center  
Code 1552  
Bethesda, MD 20084

Dr. William B. Morgan  
David W. Taylor Naval Ship Research  
and Development Center  
Code 1540  
Bethesda, MD 20084

Director, Office of Naval Research—  
Eastern/Central Regional Office (Boston)  
Building 114, Section D  
666 Summer Street  
Boston, MA 02210

Library  
Naval Weapons Center  
China Lake, CA 93555

Technical Library  
Naval Surface Weapons Center  
Dahlgren Laboratory  
Dahlgren, VA 22418

Technical Documents Center  
Army Mobility Equipment Research Center  
Building 315  
Fort Belvoir, VA 22060

Technical Library  
Webb Institute of Naval Architecture  
Glen Cove, NY 11542

Dr. J. P. Breslin  
Stevens Institute of Technology  
Davidson Laboratory  
Castle Point Station  
Hoboken, NJ 07030

Professor Louis Landweber  
The University of Iowa  
Institute of Hydraulic Research  
Iowa City, IA 52242

Fenton Kennedy Document Library  
The Johns Hopkins University  
Applied Physics Laboratory  
Johns Hopkins Road  
Laurel, MD 20810

Lorenz G. Straub Library  
University of Minnesota  
St. Anthony Falls Hydraulic Laboratory  
Minneapolis, MN 55414

Library  
Naval Postgraduate School  
Monterey, CA 93940

Technical Library  
Naval Underwater Systems Center  
Newport, RI 02840

Engineering Societies Library  
345 East 47th Street  
New York, NY 10017

The Society of Naval Architects and  
Marine Engineers  
One World Trade Center, Suite 1369  
New York, NY 10048

Technical Library  
Naval Coastal Systems Laboratory  
Panama City, FL 32401

Professor Theodore Y. Wu  
California Institute of Technology  
Engineering Science Department  
Pasadena, CA 91125

Director, Office of Naval Research -  
Western Regional Office (Pasadena)  
1030 E. Green Street  
Pasadena, CA 91101

Technical Library  
Naval Ship Engineering Center  
Philadelphia Division  
Philadelphia, PA 19112

Army Research Office  
P. O. Box 12211  
Research Triangle Park, NC 27709

Editor  
Applied Mechanics Review  
Southwest Research Institute  
8500 Culebra Road  
San Antonio, TX 78206

Technical Library  
Naval Ocean Systems Center  
San Diego, CA 92152

ONR Scientific Liaison Group  
American Embassy - Room A-407  
APO San Francisco, CA 96503

Librarian  
Naval Surface Weapons Center  
White Oak Laboratory  
Silver Spring, MD 20910

Defense Research and Development Attache  
Australian Embassy  
1601 Massachusetts Avenue, NW  
Washington, DC 20036

Librarian Station 5-2  
Coast Guard Headquarters  
NASSIF Building  
400 Seventh Street, SW  
Washington, DC 20591

Library of Congress  
Science and Technology Division  
Washington, DC 20540

Dr. A. L. Slafkosky  
Scientific Advisor  
Commandant of the Marine Corps  
Code AX  
Washington, DC 20380

Maritime Administration  
Office of Maritime Technology  
14th & E Streets, NW  
Washington, DC 20230

Maritime Administration  
Division of Naval Architecture  
14th & E Streets, NW  
Washington, DC 20230

Dr. G. Kulin  
National Bureau of Standards  
Mechanics Section  
Washington, DC 20234

Naval Research Laboratory  
Code 2627  
Washington, DC 20375 (6 copies)

Library  
Naval Sea Systems Command  
Code 09GS  
Washington, DC 20362

Mr. Thomas E. Peirce  
Naval Sea Systems Command  
Code 03512  
Washington, DC 20362

Professor Paul Lieber  
University of California  
Department of Mechanical Engineering  
Berkeley, CA 94720

Professor C. C. Mei  
Massachusetts Institute of Technology  
Department of Civil Engineering  
Cambridge, MA 02139

Professor Justin E. Kerwin  
Massachusetts Institute of Technology  
Department of Ocean Engineering  
Cambridge, MA 02139

Professor Phillip Mandel  
Massachusetts Institute of Technology  
Department of Ocean Engineering  
Cambridge, MA 02139

Professor J. Nicholas Newman  
Massachusetts Institute of Technology  
Department of Ocean Engineering  
Room 5-324A  
Cambridge, MA 02139

Professor Francis Noblesse  
Massachusetts Institute of Technology  
Department of Ocean Engineering  
Cambridge, MA 02139

Professor Ronald W. Yeung  
Massachusetts Institute of Technology  
Department of Ocean Engineering  
Cambridge, MA 02139

Dr. Robert K. C. Chan  
JAYCOR  
1401 Camino Del Mar  
Del Mar, CA 92014

Mr. Marshall P. Tulin  
Hydronautics, Incorporated  
7210 Pindell School Road  
Laurel, MD 20810

Naval Ship Engineering Center  
Code 6110  
Washington, DC 20362

Naval Ship Engineering Center  
Code 6114  
Washington, DC 20362

Naval Ship Engineering Center  
Code 6136  
Washington, DC 20362

Commandant, U.S. Coast Guard  
G-OMI/31  
2100 Second Street, Southwest  
Washington, D.C. 20593

**DAT  
FILM**

**6-8**