

AD-A084 706

NAVAL OCEAN SYSTEMS CENTER SAN DIEGO CA  
WIDEBAND UNDERWATER ACOUSTIC FACILITY.(U)  
APR 80 S K OTTINGER, P E NACHTIGALL, J E HAUN

F/6 20/1

UNCLASSIFIED

NOSC/TR-537

NL

1 of 1  
AD  
AD/RC FOR

NOSC

0

END  
DATE  
FILMED  
6-80  
DTIC

ADA 084706  
NOSC TR 537

# NOSC

NOSC TR 537

Technical Report 537

## WIDEBAND UNDERWATER ACOUSTIC FACILITY

GK Ottinger  
PE Nachtigall  
JE Haun  
GE Lingle

April 1980

Final Report: October 1978 - February 1979

Prepared for  
Naval Sea Systems Command

Approved for public release; distribution unlimited

NAVAL OCEAN SYSTEMS CENTER  
SAN DIEGO, CALIFORNIA 92152

A

80 2 07 0-8



NAVAL OCEAN SYSTEMS CENTER, SAN DIEGO, CA 92152

---

AN ACTIVITY OF THE NAVAL MATERIAL COMMAND

**SL GUILLE, CAPT, USN**

*Commander*

**HL BLOOD**

*Technical Director*

### ADMINISTRATIVE INFORMATION

This facility was designed and fabricated at the Naval Ocean Systems Center, Hawaii Laboratory, in support of the Advanced Marine Biological Systems program, sponsored by Naval Sea Systems Command, program element number 63709N.

The authors gratefully acknowledge the assistance of Patrick Moore in keeping this system operational and reviewing the manuscript. Thanks are also due to Robert Floyd for reviewing this paper for technical accuracy.

Released by  
**JM STALLARD**, Head  
Bioacoustics and Bionics Division

Under authority of  
**HO PORTER**, Head  
Biosciences Department

UNCLASSIFIED

SECURITY CLASSIFICATION OF THIS PAGE (When Data Entered)

| REPORT DOCUMENTATION PAGE  |                                     | READ INSTRUCTIONS<br>BEFORE COMPLETING FORM   |
|--|-------------------------------------|---|
| 1. REPORT NUMBER<br>NOSC TR-537  | 2. GOVT ACCESSION NO.<br>AD-A084706 | 3. RECIPIENT'S CATALOG NUMBER   |
| 4. TITLE (and Subtitle)<br>WIDEBAND UNDERWATER ACOUSTIC FACILITY.  |                                     | 5. TYPE OF REPORT & PERIOD COVERED<br>Final - Oct 78 - Feb 79                                       |
|  |                                     | 6. PERFORMING ORG. REPORT NUMBER  |
| 7. AUTHOR(s)<br>G. K. Ottinger J. E. Haun<br>P. E. Nachtigall G. E. Lingle   |                                     | 8. CONTRACT OR GRANT NUMBER(s)<br><br>16 17   |
| 9. PERFORMING ORGANIZATION NAME AND ADDRESS<br>Naval Ocean Systems Center, Hawaii Laboratory<br>P. O. Box 997<br>Kailua, Hawaii 96734  |                                     | 10. PROGRAM ELEMENT, PROJECT, TASK AREA & WORK UNIT NUMBERS<br>63709N S0214-AS S0214-AS<br>510-MM01 |
| 11. CONTROLLING OFFICE NAME AND ADDRESS<br>Commander<br>Naval Sea Systems Command<br>Washington, D. C. 20362   |                                     | 12. REPORT DATE<br>Apr 1980 12/18   |
| 14. MONITORING AGENCY NAME & ADDRESS (if different from Controlling Office)<br>Fiona St. Rd - Oct 77   |                                     | 13. NUMBER OF PAGES<br>16   |
|  |                                     | 15. SECURITY CLASS. (of this report)<br>Unclassified  |
|  |                                     | 15a. DECLASSIFICATION/DOWNGRADING SCHEDULE  |
| 16. DISTRIBUTION STATEMENT (of this Report)<br><br>Approved for public release; distribution unlimited   |                                     |   |
| 17. DISTRIBUTION STATEMENT (of the abstract entered in Block 20, if different from Report)   |                                     |   |
| 18. SUPPLEMENTARY NOTES  |                                     |   |
| 19. KEY WORDS (Continue on reverse side if necessary and identify by block number)<br>Frequency spectrum Wideband<br>Hydroacoustics<br>Spectrum analysis<br>Transducer array<br>Underwater acoustics   |                                     |   |
| 20. ABSTRACT (Continue on reverse side if necessary and identify by block number)<br><br>A wideband underwater acoustic facility was developed to project and analyze underwater sounds from 44 Hz to 160 kHz. The unique sound projecting system for this facility is composed of a multi-transducer array with individual amplifiers and equalizers to reproduce a relatively flat 165 dB re 1 $\mu$ Pa broadband acoustic signal with a linearity of $\pm 8$ dB. The analyzing system utilizes a broadband omnidirectional hydrophone, a frequency analyzer with a transducer, and a tape recorder to analyze the signals from the sound projecting system. |                                     |   |

DD FORM 1473 1 JAN 73

EDITION OF 1 NOV 65 IS OBSOLETE  
S/N 0102-LF-014-6601

UNCLASSIFIED

SECURITY CLASSIFICATION OF THIS PAGE (When Data Entered)

373151

UNCLASSIFIED

SECURITY CLASSIFICATION OF THIS PAGE (When Data Entered)

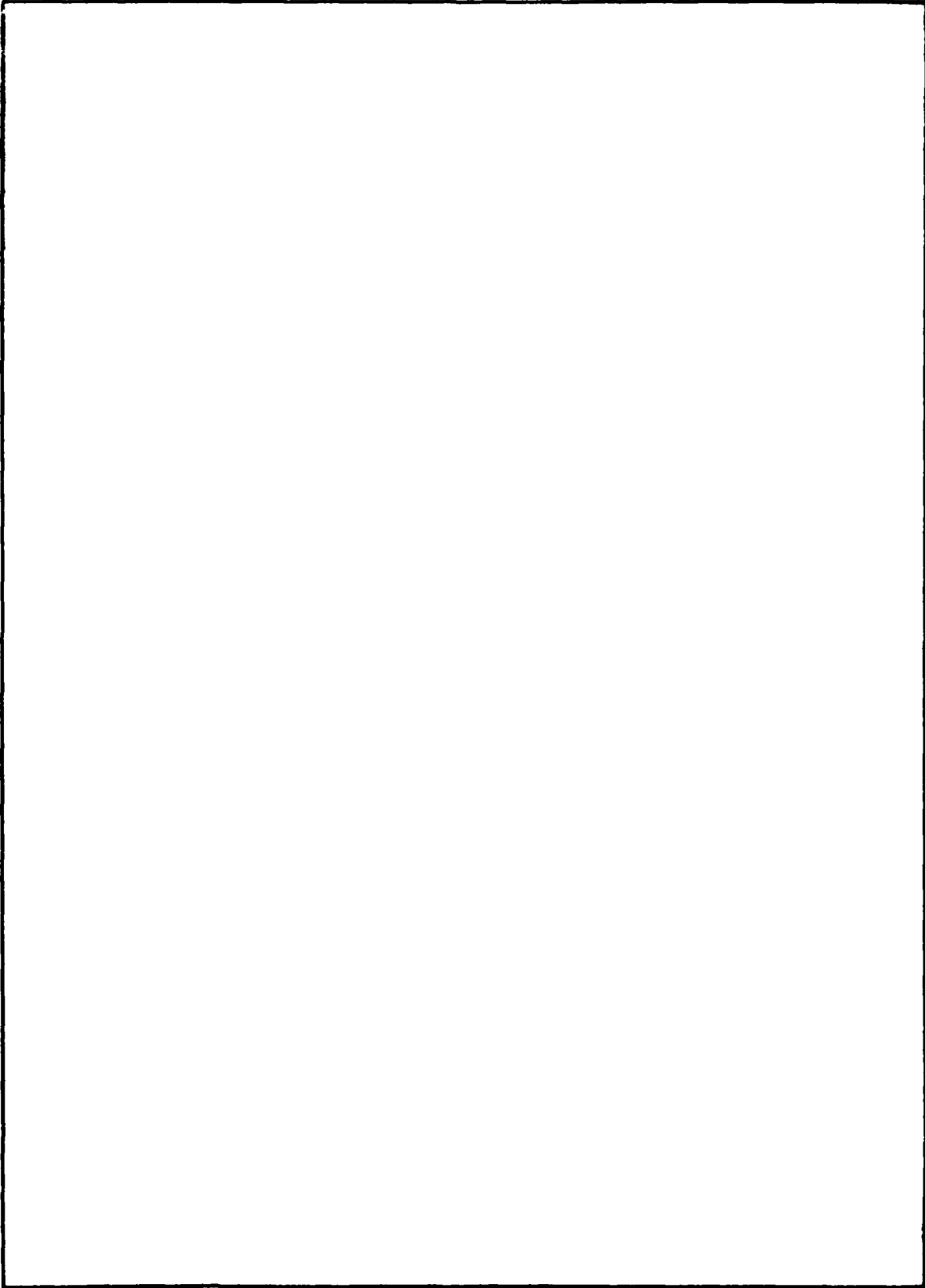

UNCLASSIFIED

SECURITY CLASSIFICATION OF THIS PAGE(When Data Entered)

## OBJECTIVE

The objective of this project was to design and build a wideband underwater acoustic generating system with associated test equipment and to measure the parameters of the signals produced. The system was constructed, tested, and evaluated under operational conditions.

## RESULTS

1. An acoustic system with a unique filter equalization circuit was designed by project personnel specifically for the multi-transducer array and was the key to generating a relatively undistorted underwater signal.
2. The dynamic capabilities of this sound system, as measured by broadband analyzing and recording equipment, ranged from 44 Hz to 160 kHz with a maximum output level of 165 dB re 1  $\mu$ Pa ( $w$  1 m and a linearity of  $\pm 8$  dB).

## RECOMMENDATIONS

Since it has been demonstrated that a relatively undistorted wideband underwater sound can be produced, current technology in transducer and integrated circuit design should be applied in an effort to reduce the power requirements and consolidate the instrumentation used in the system.

A

## CONTENTS

|   |    |
|---|----|
| INTRODUCTION . . . . .  | 3  |
| SIGNAL GENERATION AND TRANSMISSION . . . . .                                  | 3  |
| RECEIVING AND ANALYSIS SYSTEM . . . . .                                       | 7  |
| SUMMARY . . . . .   | 8  |
| APPENDIX A: EQUIPMENT BLOCK DIAGRAM . . . . .                                 | 9  |
| APPENDIX B: EQUIPMENT LISTING . . . . .                                       | 10 |
| APPENDIX C: HYDROPHONE AND UNDERWATER PROJECTOR CALIBRATION<br>DATA . . . . . | 12 |

## INTRODUCTION

The wideband acoustic facility provides a unique capability to project, monitor, record and analyze wideband underwater acoustic signals with a maximum output level of 165 dB re 1  $\mu$ Pa @ 1m and a linearity of  $\pm 8$  dB in a frequency range from 44 Hz to 160 kHz. This is accomplished by an array of four electroacoustic transducers with associated frequency equalizer and power amplifier to provide the wide bandwidth and required power. A hydrophone monitors the acoustic output, a spectrum analyzer provides a real time analysis capability, and an instrumentation magnetic tape recorder records signals of interest.

This report describes how the signals are generated, transmitted, monitored, recorded, and analyzed.

## SIGNAL GENERATION AND TRANSMISSION

The underwater acoustic signal generation and transmission system is comprised of a signal source, signal control and equalization circuitry, four power amplifiers with matching transformers, and four electroacoustic transducers forming an array to physically generate and project signals underwater. A block diagram representation of the system is shown in figure 1.

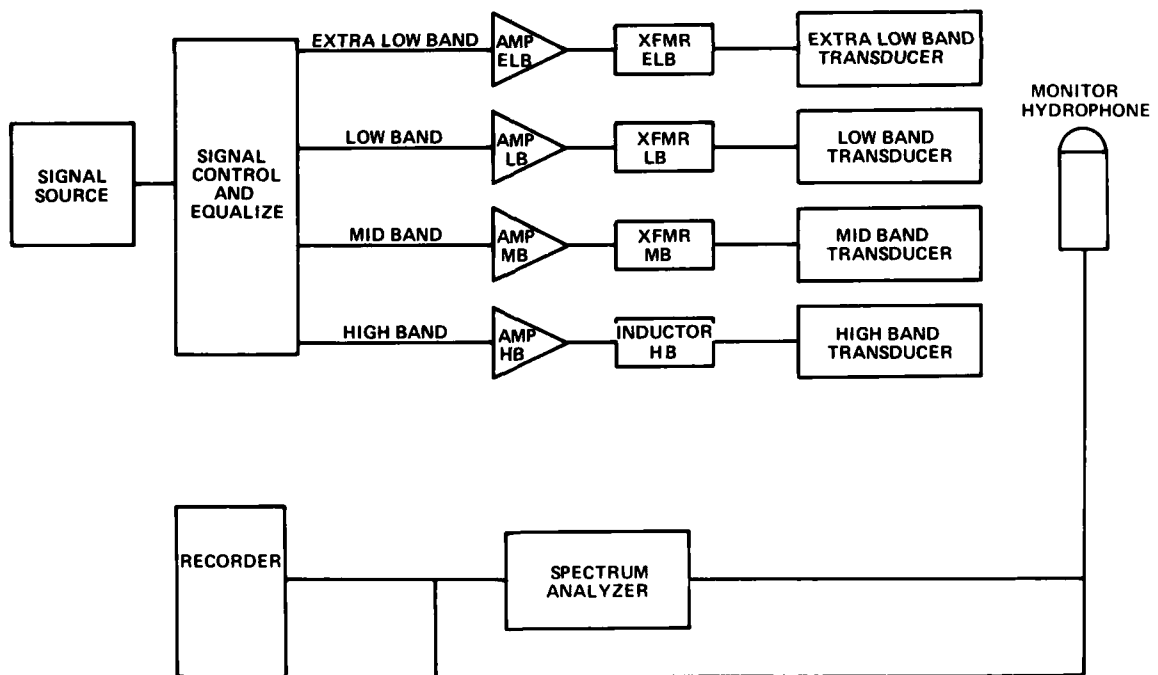

Figure 1. Wideband underwater acoustic transmission system.

In this system, the electrical signal source can be either a wideband magnetic tape recorder, a general purpose signal generator, or a random noise generator. However, any compatible signal source could be used. The random noise generator and signal generator are used primarily for system tuning and calibration, with the tape recorder providing the primary source of signals of interest.

The signal control and equalization circuitry as shown in figure 2 provides operator control of signal input and output switching, along with amplitude gain and amplitude equalization with frequency. The operator can select up to 14 input signals which are buffered, summed, and presented to the quiet switch.

The quiet switch is a gated amplifier that provides a gradual rise time (or decay for turnoff time) of the output signal amplitude when enabled. The "start" pushbutton enables the quiet switch, the event clock, and the event clock's digital readout. When enabled, the signal is gated through the quiet switch, and amplified by the operator-controlled variable gain amplifier, for distribution to the frequency equalizers, power amplifiers, and output transducers. The quiet switch output is disabled (after a random time delay of two to seven seconds) by the operator-controlled "stop" pushbutton.

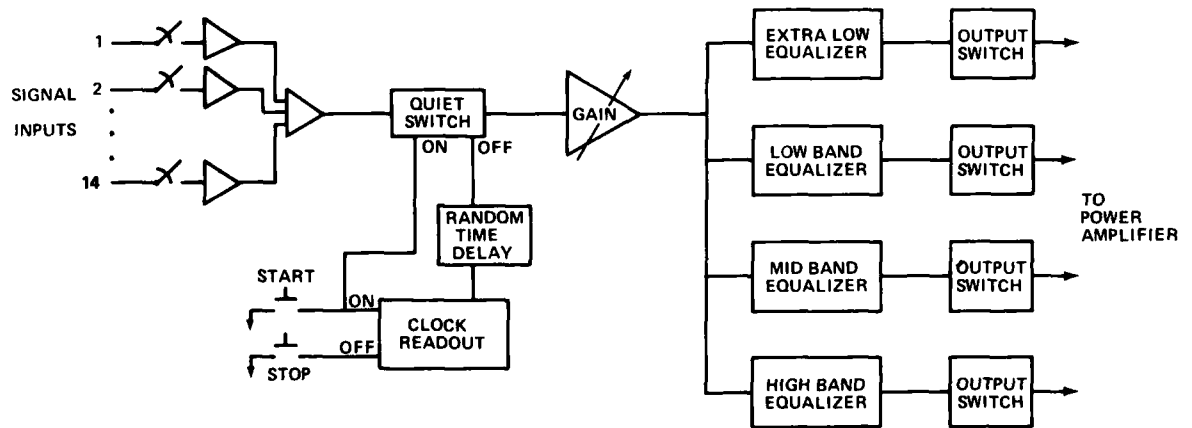

Figure 2. Signal control and equalization circuitry.

The frequency equalization circuits shape the signal so that the transducer's output in the water is a "good replica" of the signal originating from either the magnetic tape recorder or other signal sources. The equalizer circuits were designed specifically for the transducers they feed, and are unique as such. The frequency response of each equalizer is designed to be the inverse of its transducer's response so that a signal passing through both will emerge as an undistorted replica of the original signal.

Each of the equalizers has input and output variable gain amplifiers with cascaded operational amplifier filters, as shown in figure 3. The frequency response of the filters is adjustable by either reactive component replacement and/or potentiometer gain adjustment. Each of the equalizers was fine tuned to provide the best signal replication in the water. The equalized signals are then passed to the power amplifiers, transformers, and finally the output transducers.

The four power amplifiers receive the equalized signals and amplify these signals for transmission by the transducers. The power amplifiers' output impedances are matched to the transducers' input impedances with inductors or impedance matching transformers so maximum power transfer will occur.

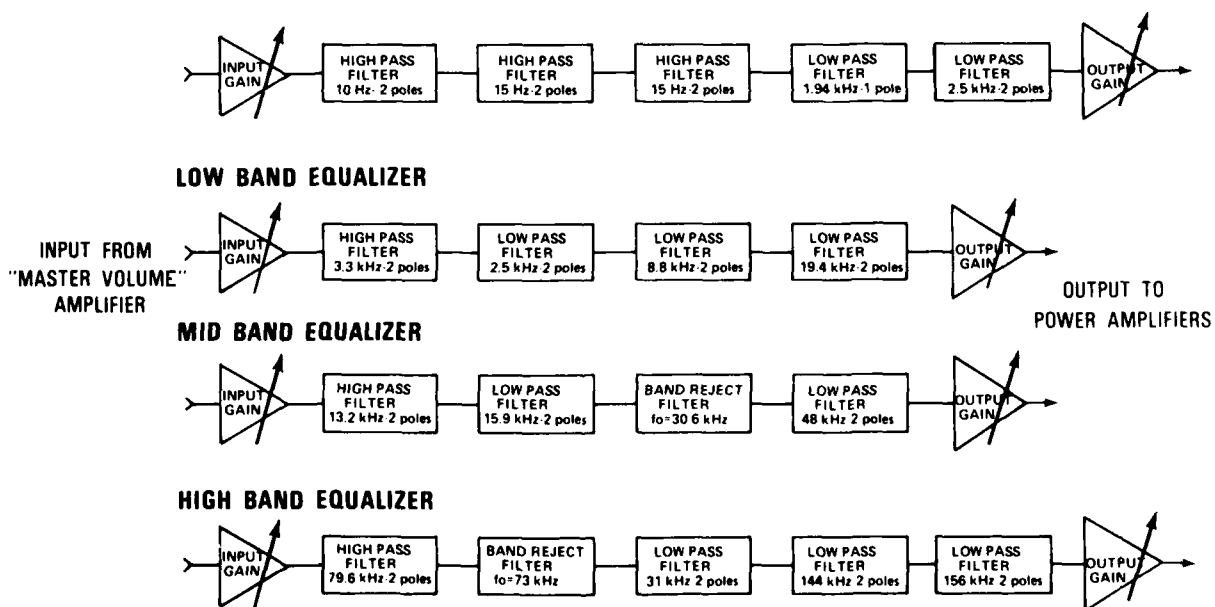

Figure 3. Frequency equalizers.

The four transducers (projectors) with contiguous operating frequency ranges and similar source levels were formed into a transmitting array in order to provide a constant power spectral density (i.e., a flat transmitted power frequency response) from 44 Hz to 160 kHz. The transducers receive the signals that have been shaped by the equalizers and amplified by the power amplifiers. All four transducers were designed and/or manufactured by the Underwater Sound Reference Division of the Naval Research Laboratory (USRD-NRL) in Orlando, Florida. The transducers are mounted coplanar in an array, as shown in figure 4, to approximate an omnidirectional wideband point source. The array was mounted on a vertical sled for insertion and removal from the water with a manual winch and pier davit.

CENTER MARKS OF F-42C AND  
F-42D ARE IN LINE WITH  
FACE OF F-40

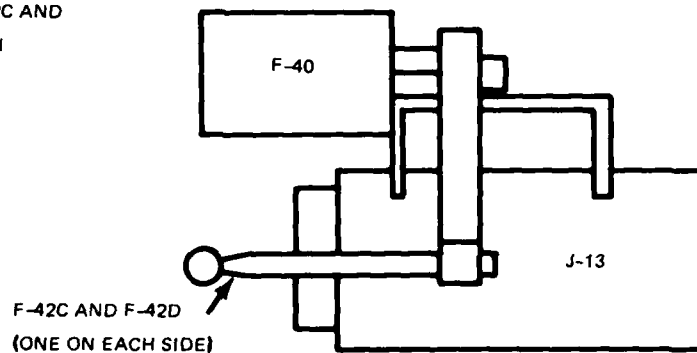

Figure 4. Underwater transducer array.

The largest projector in the array is a USRD-NRL model J-13 moving coil electro-acoustic transducer that covers the extra low frequency band of 44 Hz to 2 kHz. The low frequency band of 2 kHz to 20 kHz is covered with a USRD-NRL model F-40 lead zirconate titanate (LZT) transducer. A USRD-NRL model F-42B LZT transducer is used to cover the midband from 20 kHz to 60 kHz. The high frequency band from 60 kHz to 160 kHz was covered by a USRD-NRL model F-42D transducer. The transducer power outputs were balanced across the band from 44 Hz to 160 kHz by equalizer and/or power amplifier adjustments while projecting broadband (500 kHz) white noise, as shown in figure 5.

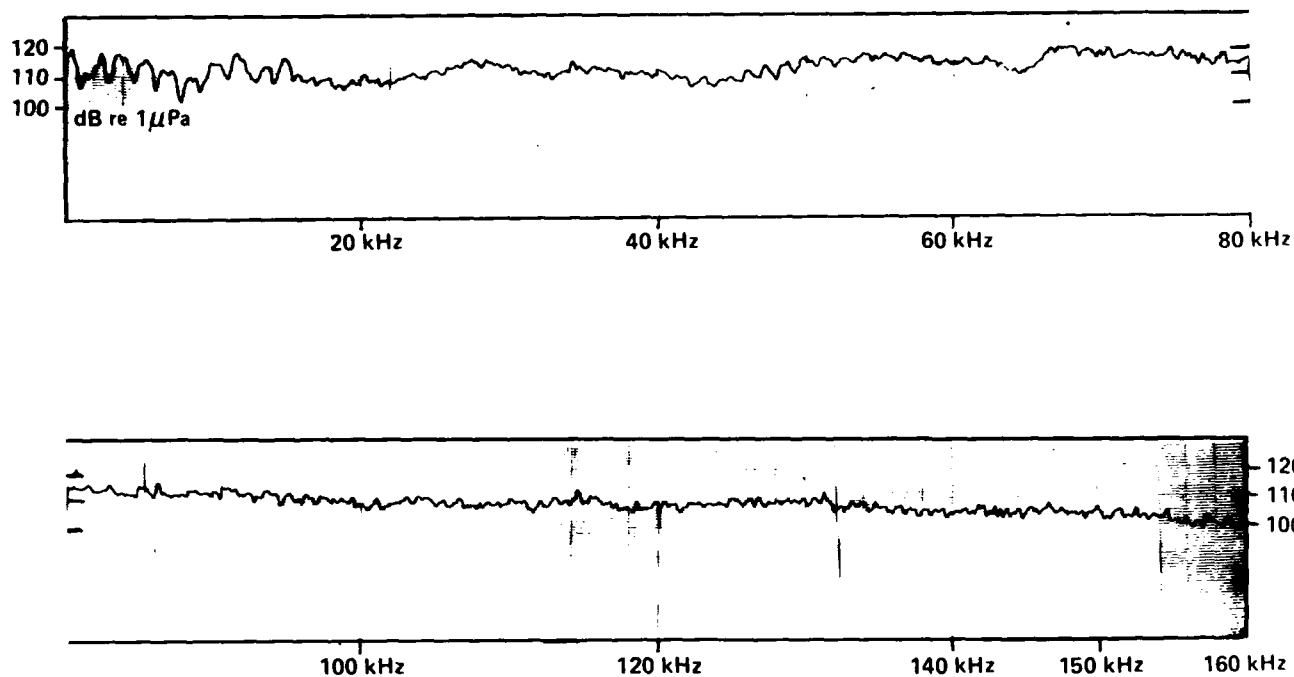

Figure 5. Transducer equalized power spectrum.

### RECEIVING AND ANALYSIS SYSTEM

The receiving system consists of a broadband hydrophone and a high gain amplifier. The hydrophone, a Bruel & Kjaer model 8103 LST transducer, is omnidirectional with a flat ( $\pm 2$  dB) frequency response from 1 Hz to 120 kHz and a useful ( $\pm 10$  dB) frequency response to 200 kHz. The hydrophone receiving sensitivity is  $-211$  dB re  $1V/\mu Pa$ . This value is flat ( $\pm 2$  dB) in the horizontal plane below 200 kHz and in the vertical plane below 100 kHz. The hydrophone is pole mounted 1 metre from the radiating face of the array to constantly monitor the array output.

The relatively low voltage signal from the monitor hydrophone is amplified by 1000 with a Bruel & Kjaer model 2635 charge amplifier. This high level signal is then distributed to a Kudelski audio amplifier/loudspeaker for aural monitoring and to the spectrum analyzer.

The spectrum analyzer is a Spectral Dynamics model 330 time compression analyzer with a Spectral Dynamics model 332 translator, permitting real-time analysis of any 20-kHz band up to 150-kHz band center frequency. Signal spectrum analysis can be in real time or ensemble averages with linear or exponential weighting. Since the hydrophone receiving sensitivity and amplifier gain are known, the signal measurements can be referenced to absolute sound pressure levels in the water.

The spectrum analyzer output is recorded on a Hewlett Packard model 7035 hard-copy X-Y recorder with either linear or logarithmic amplitude display.

Acoustic events can be recorded on the Ampex model FR-1200, 14-channel wide-band instrumentation magnetic tape recorder. In the direct recording mode with Ampex 756 magnetic recording tape, the model FR-1200 provides a bandwidth from 150 Hz to 150 kHz ( $\pm 3$  dB) with a 32-dB dynamic range at 30 ips. A wider signal dynamic range can be accommodated easily by adjusting the input signal gain in known increments (e.g., 10 dB) and recording the same signal but with the different gain levels. Ancillary information such as time codes, event counter, voice annotation etc. can be recorded easily for future reference.

#### SUMMARY

A unique underwater acoustic facility was designed and assembled to reproduce and analyze wideband underwater sounds. This system has the capability to project underwater sounds from 44 Hz to 160 kHz with an output level of 165 dB re  $1 \mu\text{Pa}$  @ 1m and a linearity of  $\pm 8$  dB. The analyzing and recording equipment used assisted in the development of the sound generating system and made it possible to analyze other broadband signals of interest.

APPENDIX A: EQUIPMENT BLOCK DIAGRAM

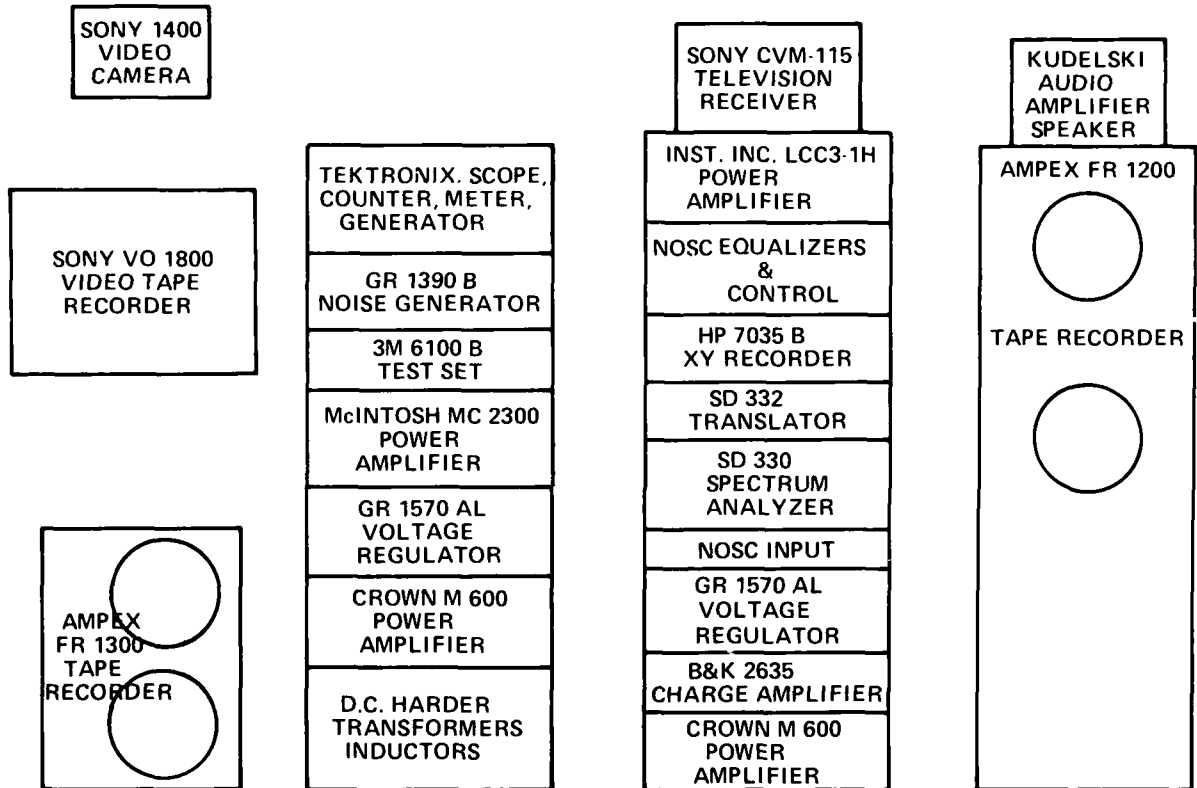

## APPENDIX B: EQUIPMENT

|                                  |                               |                                  |
|----------------------------------|-------------------------------|----------------------------------|
| Tape Recorder                    | Ampex FR 1200 S/N 1P2588      | Ampex Corp., Redwood City, CA    |
| Tape Recorder                    | Ampex FR 1300 S/N 1220404     | Ampex Corp., Redwood City, CA    |
| Spectrum Analyzer                | Spectral Dynamics 330 S/N 143 | Spectral Dynamics, San Diego, CA |
| Spectrum Translator              | Spectral Dynamics 332 S/N 315 | Spectral Dynamics, San Diego, CA |
| Random Noise Generator           | Gen Rad 139B S/N 10350        | General Radio, Concord, MA       |
| Oscilloscope                     | Tektronix SC 502 S/N B023970  | Tektronix, Beaverton, OR         |
| Universal Counter                | Tektronix DC 503 S/N B167818  | Tektronix, Beaverton, OR         |
| Function Generator               | Tektronix FG 501 S/N B128916  | Tektronix, Beaverton, OR         |
| Digital Multimeter               | Tektronix DM 502 S/N B029642  | Tektronix, Beaverton, OR         |
| Hydrophone                       | B & K 8103 S/N 680923         | Bruel & Kjaer, Denmark           |
| Hydrophone Amplifier             | B & K 2635 S/N 699667         | Bruel & Kjaer, Denmark           |
| Test Set                         | 3M 6100B S/N 00155            | 3M, Camarillo, CA                |
| X-Y Recorder                     | H.P. 7035 S/N 1447A0741       | Hewlett Packard, Palo Alto, CA   |
| Audio Amplifier &<br>Loudspeaker | Kudelski S/N 1634             | Kudelski, Paudex, Switzerland    |
| Voltage Regulator 1              | GR 1570 AL S/N 3907           | General Radio, Concord, MA       |
| Voltage Regulator 2              | GR 1570 AL S/N 4439           | General Radio, Concord, MA       |

### Extra Low Band 44 Hz - 2 kHz

|             |                       |   |
|-------------|-----------------------|---|
| Amplifier   | Crown M 600 S/N 407   | Crown Int., Elkhart, Ind.                           |
| Transformer | D.C. Harder P/N 98209 | D.C. Harder Co., San Diego, CA                      |
| Transducer* | USN J-13 S/N 20       | NRL-Underwater Sound Reference<br>Div., Orlando, FL |
| Equalizer†  | USN-Experimental      | Naval Ocean Systems Center, Kailua,<br>HI           |

### Low Band 2 kHz - 20 kHz

|             |                           |   |
|-------------|---------------------------|---|
| Amplifier   | McIntosh MC2300 S/N 1Y548 | McIntosh Lab., Binghamton, NY                       |
| Transformer | D.C. Harder P/N 98210     | D.C. Harder Co., San Diego, CA                      |
| Transducer* | USN F-40 S/N 38           | NRL-Underwater Sound Reference<br>Div., Orlando, FL |
| Equalizer†  | USN-Experimental          | Naval Ocean Systems Center, Kailua,<br>HI           |

### MidBand 20 kHz - 60 kHz

|             |                       |   |
|-------------|-----------------------|---|
| Amplifier   | Crown M600 S/N 385    | Crown Int., Elkhart, Ind.                           |
| Transformer | D.C. Harder P/N 98222 | D.C. Harder Co., San Diego, CA                      |
| Inductor    | D.C. Harder P/N 98203 |   |
| Transducer* | USN F-42B S/N 4       | NRL-Underwater Sound Reference<br>Div., Orlando, FL |
| Equalizer†  | USN-Experimental      | Naval Ocean Systems Center, Kailua,<br>HI           |

High Band 60 kHz - 160 kHz

|             |                            |   |
|-------------|----------------------------|---|
| Amplifier   | Inst. Inc. LCC3-1A S/N 001 | Instruments Inc., San Diego, CA                     |
| Inductor    | D.C. Harder P/N 98202      | D.C. Harder Co., San Diego, CA                      |
| Transducer* | USN F-42D S/N 6            | NRL-Underwater Sound Reference<br>Div., Orlando, FL |
| Equalizer†  | USN-Experimental           | Naval Ocean Systems Center, Kailua,<br>HI           |

\* See Appendix A for transducer calibration information.

† Equalizers for all frequency bands are individually manufactured by Naval Ocean Systems Center, Kailua, HI.

|                     |                         |                           |
|---------------------|-------------------------|---------------------------|
| Video Tape Recorder | Sony VO-1800 S/N 13971  | Sony Corp., Tokyo, Japan  |
| Video Camera        | Sony AVC 1400 S/N 23762 | Sony Corp., Tokyo, Japan  |
| Television Receiver | Sony CVM-115 10672      | Sony Corp., Tokyo, Japan  |
| Array Winch         | Thern 402               | Thern Inc., Winona, Minn. |

## **APPENDIX C: HYDROPHONE AND UNDERWATER PROJECTOR CALIBRATION DATA**

These calibration data were taken at NOSC's Evaluation Center, San Diego, CA. The Bruel & Kjaer 8103 hydrophone data were supplied by the manufacturer.

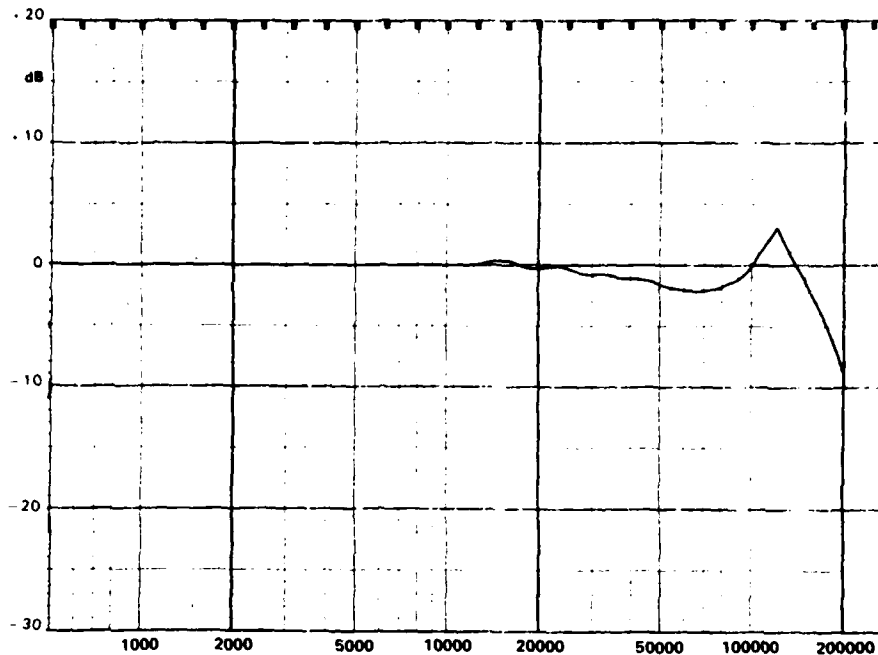

**Calibration Chart for  
Hydrophone Type 8103**

Serial No. 680923

**Bruel & Kjaer**



Reference Sensitivity at 250 Hz\* at 23 °C  
including 6 m integral cable

Cable Capacitance 95 pF/m typical

Open Circuit Sensitivity

Voltage Sensitivity  
 - 210.7 dB re 1 V/μPa\*\*  
 - 90.7 dB re 1 V per Pa or 29.2 μV per Pa  
 110.7 dB re 1 V per μbar\*\*

Charge Sensitivity 103 · 10<sup>-3</sup> pC per Pa

Capacitance (including 6 m cable) 3540 pF

Frequency Response  
 Individual Free Field Frequency Response Curve  
 attached

Date 3/1/77 Signature J D

Summarized Specifications  
 Usable Frequency Range 0.1 Hz to 200 kHz (-10 dB)

Linear Frequency Range  
 0.1 Hz to 20 kHz - 1 dB  
 0.1 Hz to 140 kHz - 2 dB

Horizontal Directivity 200 kHz (XY plane)  
 typical - 2 dB

Vertical Directivity 100 kHz (XZ plane)  
 typical - 4 dB

8C 0094

**Physical**

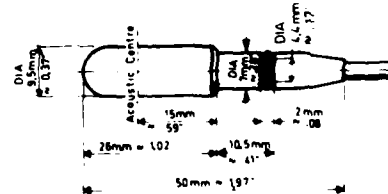

Leakage Resistance  
 $> 110^6 \text{ M}\Omega$  at 23 °C

Operating Temperature Range  
 - 40°C to + 120°C  
 - 40°F to + 248°F

Change of Sensitivity with Temperature  
 Charge - 0.03 dB/°C  
 Voltage - 0.03 dB/°C

Change of Sensitivity with Static Pressure  
 3 - 10<sup>-7</sup> dB/Pa (0.03 dB/atm)

Temperature Transient Sensitivity - 50 Pa/°C  
 (ANSI S 2.11 1969), measured with B & K Charge  
 Pre-amplifier Type 2626 LLF 3 Hz

Allowable Total Radiation Dose 5 · 10<sup>7</sup> Rad

Acceleration Sensitivity: < 130 dB re 1 μPa/g

Maximum Operating Static Pressure  
 40 atm

Cable  
 Double shielded low noise low capacitance  
 Integral cable 6 m with miniature plug

Weight (incl cable) 170 g  
 \* Traceable to NBS  
 \*\* 1 Pascal = 1 N/m<sup>2</sup> = 10 μbar

THIS PAGE IS BEST QUALITY PRACTICABLE  
FROM COPY FURNISHED TO EDC

Figure C-1. Calibration chart for Bruel & Kjaer 8103 hydrophone.

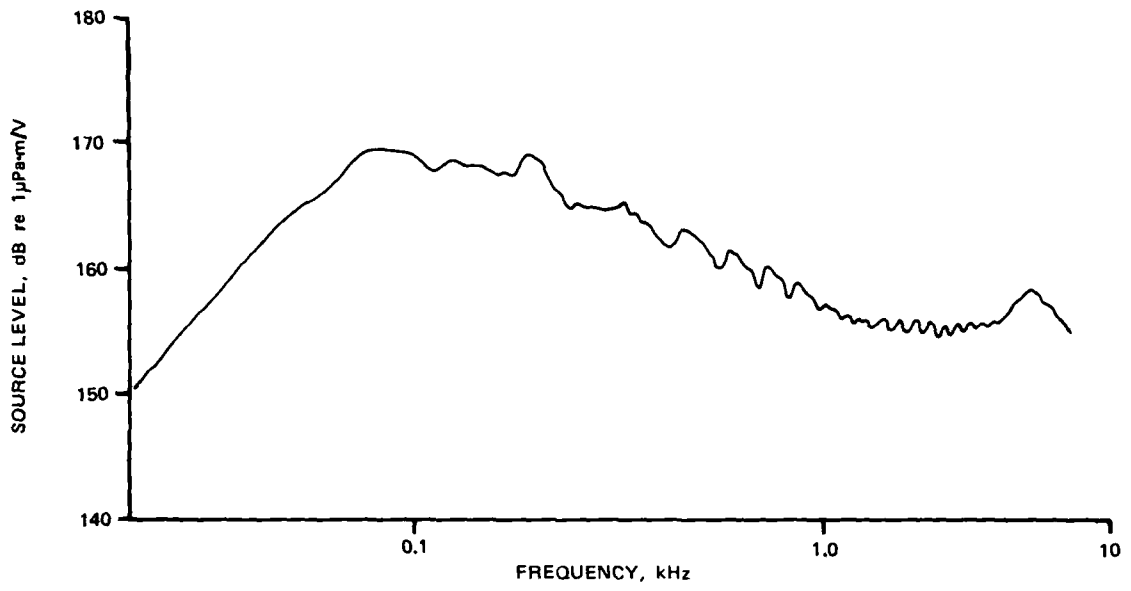

Figure C-2. J-13 transmitting voltage response.

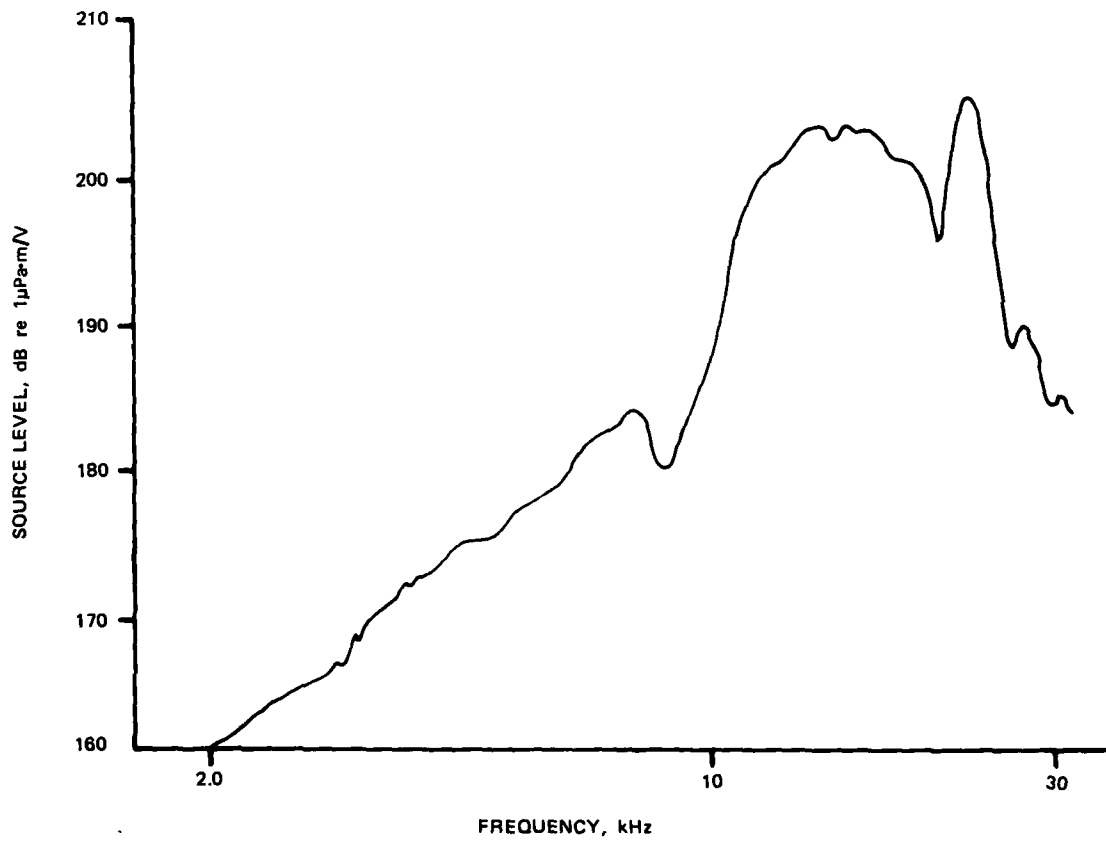

Figure C-3. F-40 transmitting voltage response.

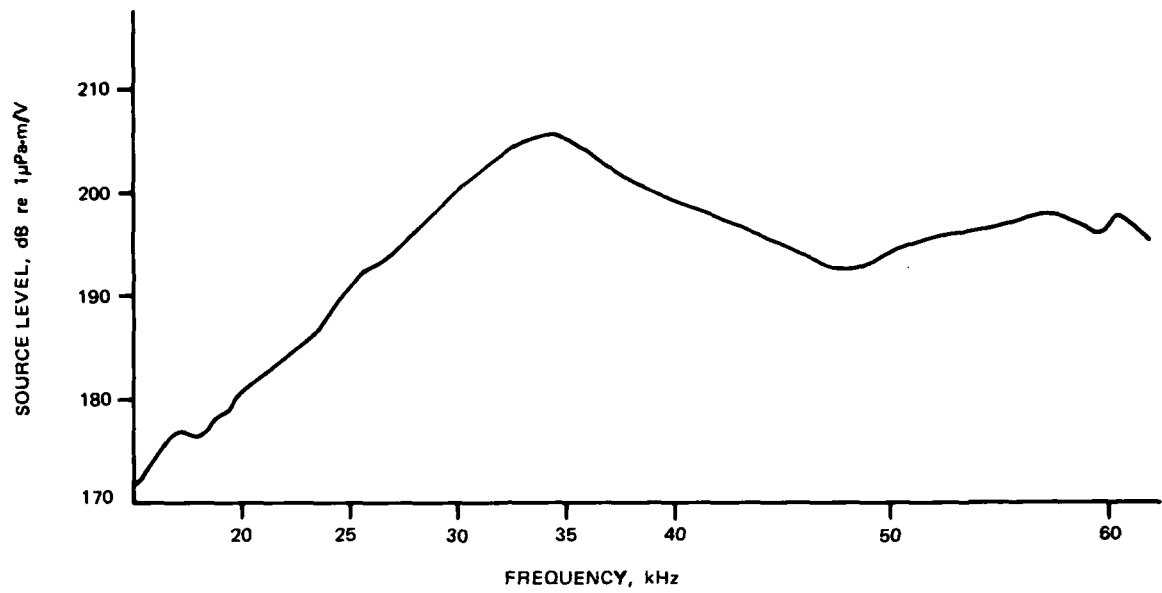

Figure C-4. F42B transmitting voltage response.

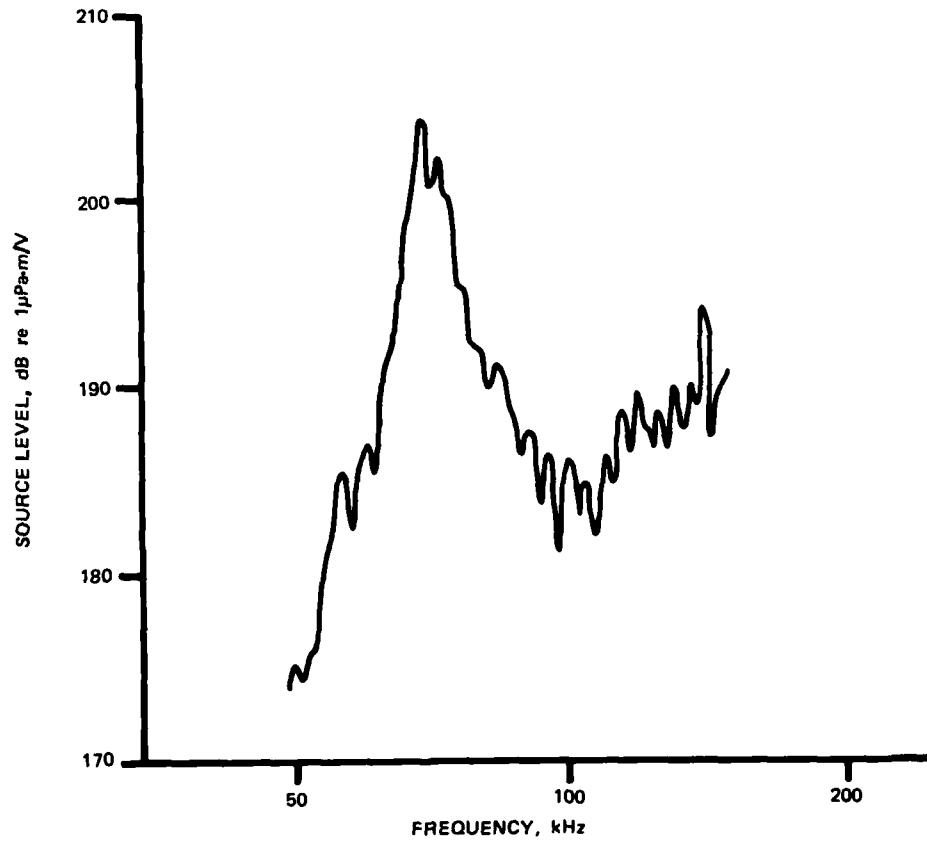

Figure C-5. F42D transmitting voltage response.