

5.2.

LEVEL

(3)

HDL-CR-80-613-1

May 1980

**A NASTRAN MODEL AND ANALYSIS
OF THE UNATTENDED EXPENDABLE
JAMMER (UEJ): FINAL REPORT**

by **JOHN T. YOUNG, Ph.D.**

ADA 085166

Prepared by
MEGA Engineering *New*
11961 Tech Road
Silver Spring MD 20904

DTIC
ELECTE
S JUN 4 1980
A

Under contract
DAAK21-80-Q-1613



**U.S. Army Electronics Research
and Development Command
Harry Diamond Laboratories
Adelphi, MD 20783**

Approved for public release; distribution unlimited.

DDC FILE COPY

80 6 2 031

The findings in this report are not to be construed as an official Department of the Army position unless so designated by other authorized documents.

Citation of manufacturers' or trade names does not constitute an official endorsement or approval of the use thereof.

Destroy this report when it is no longer needed. Do not return it to the originator.

UNCLASSIFIED

SECURITY CLASSIFICATION OF THIS PAGE (When Data Entered)

19) REPORT DOCUMENTATION PAGE		READ INSTRUCTIONS BEFORE COMPLETING FORM
18) 1. REPORT NUMBER HDL/CR-89-613-1	2. GOVT ACCESSION NO. AD-A085266	3. RECIPIENT'S CATALOG NUMBER
6) 4. TITLE (and Subtitle) A NASTRAN Model and Analysis of the Unattended Expendable Jammer (UEJ) Final Report	5. TYPE OF REPORT & PERIOD COVERED Contractor Report	
10) 7. AUTHOR John T. Young, Ph.D.	8. CONTRACT OR GRANT NUMBER(s) DA project LE463755DK12	
9. PERFORMING ORGANIZATION NAME AND ADDRESS Mega Engineering 11961 Tech Road Silver Spring, MD 20904	10. PROGRAM ELEMENT, PROJECT, TASK AREA & WORK UNIT NUMBERS 9) Final rept.	
11. CONTROLLING OFFICE NAME AND ADDRESS Harry Diamond Laboratories 2800 Powder Mill Road Adelphi, MD 20783	12. REPORT DATE May 89	13. NUMBER OF PAGES 61
14. MONITORING AGENCY NAME & ADDRESS (if different from Controlling Office)	15. SECURITY CLASS. (of this report) Unclassified	
	15a. DECLASSIFICATION/DOWNGRADING SCHEDULE N/A	
16. DISTRIBUTION STATEMENT (of this Report) Approved for public release; distribution unlimited.		
17. DISTRIBUTION STATEMENT (of the abstract entered in Block 20, if different from Report) 15) I 4-21-89-0-1-23		
18. SUPPLEMENTARY NOTES HDL Project 431948 DROMS Code 643755K120012 PRON CV9R303701C VA9		
19. KEY WORDS (Continue on reverse side if necessary and identify by block number) Unattended Expendable Jammer, NASTRAN model		
20. ABSTRACT (Continue on reverse side if necessary and identify by block number) The Harry Diamond Laboratories has developed a design and preliminary hardware for an unattended expendable jammer (UEJ) system. Each unit consists of a cylindrical steel sleeve with an integral steel base plate and an ejectable steel cover. Each package contains an electronic jamming network, an antenna, electronic printed circuit boards, and a battery pack. To analyze the stresses in a unit a NASTRAN finite element model was developed. The model consisted of 502 grid points located in a repetitive pattern at each of six		

DD FORM 1 JAN 73 1473

EDITION OF 1 NOV 65 IS OBSOLETE

UNCLASSIFIED

SECURITY CLASSIFICATION OF THIS PAGE (When Data Entered)

411911

UNCLASSIFIED

SECURITY CLASSIFICATION OF THIS PAGE(When Data Entered)

levels. Static and dynamic analyses were performed with this model for both launch (setback) and landing conditions. In the static analyses stresses and displacements in the UEJ are presented. In the modal analysis, the ten lowest mode shapes for each load case were determined. Several design recommendations have been made based on this analysis.

PROJECT NO.	
TITLE	
AUTHOR	
PERFORMING ORGANIZATION	
PUBLICATION STATEMENT	
P	
F	
S	
DISTRIBUTION STATEMENTS	
Dist	Special

UNCLASSIFIED

SECURITY CLASSIFICATION OF THIS PAGE(When Data Entered)

Table of Contents

	Page
1. Description of the Unattended Expendable Jammer.....	5
2. Description of the NASTRAN Model.....	8
3. Summary of Results for Static Analysis.....	28
4. Summary of Eigenvalue Analysis.....	39
5. Summary of Model with Detailed Cutouts.....	44
6. Conclusions.....	49

Figures

1. Side view of jammer assembly.....	6
2. Overall view of UEJ model (502 grid points).....	12
3. x-z view of UEJ model.....	13
4. y-z view of UEJ model.....	14
5. x-y view of UEJ model.....	15
6. Level 1 with grid points labeled.....	16
7. Level 2 with grid points labeled.....	17
8. Level 3 with grid points labeled.....	18
9. Level 4 with grid points labeled.....	19
10. Level 5 with grid points labeled.....	20
11. Level 6 with grid points labeled.....	21
12. Level 1 with quadrilateral and triangular plage element ID's.....	22
13. Level 4 with CROD element ID's.....	23
14. Level 4: NASTRAN model of Timer PCB superimposed over drawing of actual hardware.....	24
15. Level 5: NASTRAN model of Insert superimposed over drawing of actual hardware.....	25
16. Developed view of sleeve.....	26
17. Model of antenna and antenna part with grid points labeled.....	27
18. Plot of level 1 showing representative degrees of freedom placed in analysis set.....	41
19. Sleeve showing area modeled in detail.....	45

Tables

1. Subcase 1: Setback - Peak stresses in UEJ for 1000 g load in axial direction.....	31
2. Subcase 2: Ground impact - Peak stresses in UEJ for 1000 g load in axial direction.....	32
3. Subcase 3: Setback - Peak stresses in UEJ for 1000 g load in axial direction.....	33
4. Subcase 4: Ground impact - Peak stresses in UEJ for 1000 g load in axial direction.....	34
5. Subcase 1: Setback - Peak axial displacements in UEJ for 1000 g load in axial direction.....	35

Table of Contents (Cont'd.)

6.	Subcase 2: Ground impact - Peak axial displacements in UEJ for 1000 g load in axial direction.....	36
7.	Subcase 3: Setback - Peak axial displacements in UEJ for 1000 g load in axial direction.....	37
8.	Subcase 4: Ground impact - Peak axial displacements in UEJ for 1000 g load in axial direction.....	38
9.	Natural frequency response of UEJ during launch (setback).	42
10.	Natural frequency response of UEJ during landing	43
11.	Subcase 1: Setback - Peak stresses in UEJ model with detailed sleeve area for 1000 g load in axial direction ..	46
12.	Subcase 2: Ground impact - Peak stresses in UEJ model with detailed sleeve area for 1000 g load in axial direction.....	47
13.	Subcase 1: Setback - Peak stresses in UEJ model with detailed sleeve area, including cutout, for 1000 g load in axial direction.....	48

Appendices

A.	NASTRAN Section Properties.....	51
B.	UEJ Material Properties.....	59
	DISTRIBUTION.....	61

1. DESCRIPTION OF THE UNATTENDED EXPENDABLE JAMMER

The U. S. Army Electronics Research and Development Command, Harry Diamond Laboratories (ERADCOM-HDL), has developed a design and preliminary hardware for an unattended expendable jammer (UEJ) system. The system consists of a series of six jammers which are housed in a 155-mm howitzer M483A1 projectile. Each jammer unit consists of a cylindrical steel sleeve (5.035 inches in diameter, 0.3 inches thick and 3.5 inches deep) with an integral steel base plate and an ejectable steel cover. Each of these packages contains an electronic jamming network, a storable tubular expendable member package (STEM), electronic printed circuit boards and a battery pack which is activated by centrifugal force when the projectile is fired. See Figure 1 for details.

A series of eight vanes are attached to the side of the sleeve of each package and provide stability for the deployed jammer. Explosive charges are provided in the base plate of each package to sequentially deploy them during projectile flight. Each package will be deployed and land in a position from which the forward cover may be ejected and the antenna and a series of ground plane spools will be deployed.

During the projectile flight, the package deployment, and the landing, a series of inertial forces are created within the package due to explosive charges and setback from the projectile firing. Engineering designs currently exist for all components within the package; however, a detailed stress analysis was not made to evaluate the element component stresses and forces or to locate potential problem areas within the jammer package design.

The current system weighs about 7.94 lbs and is extremely close to the maximum allowable weight for the jammer package.

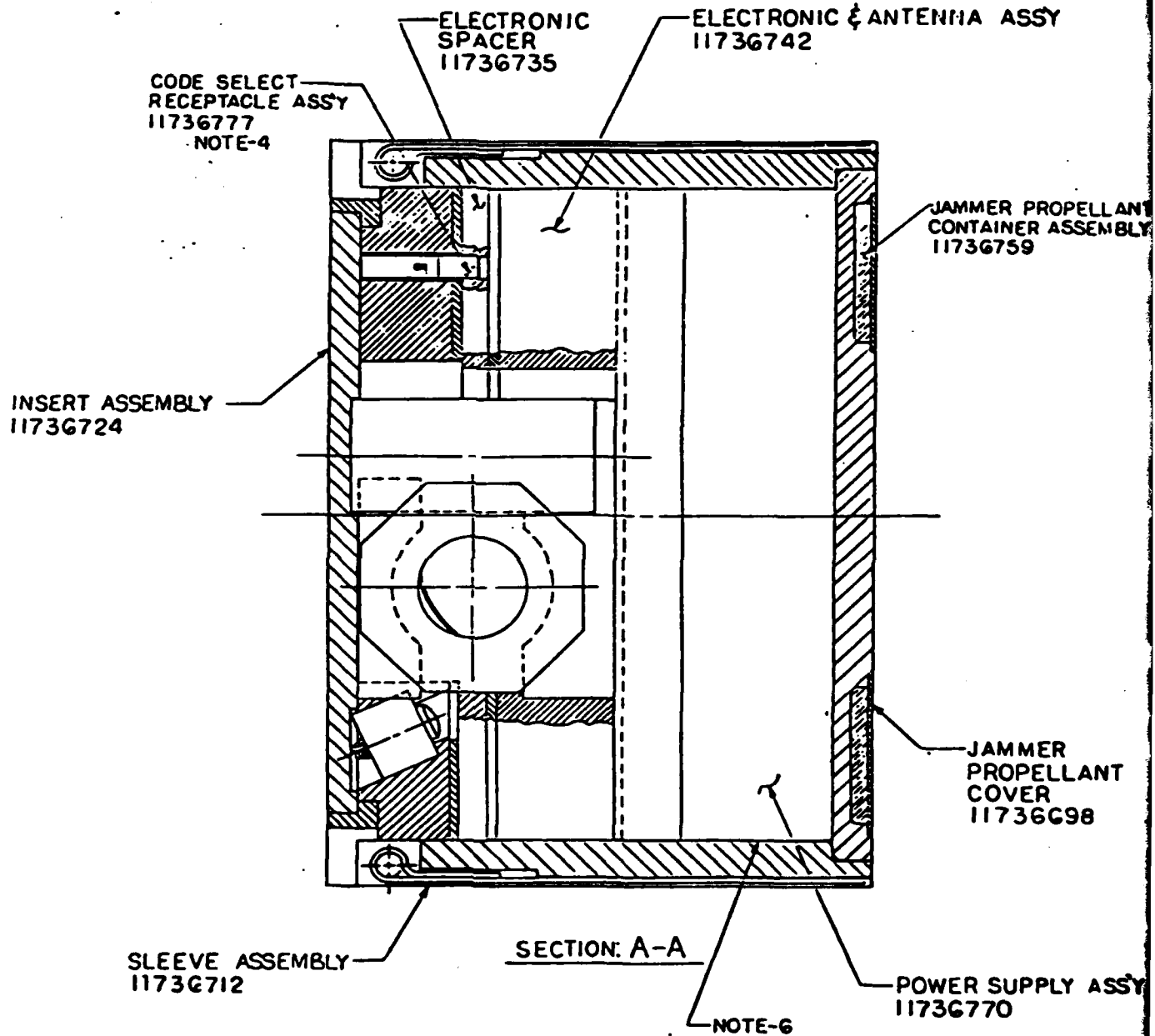

Figure 1. Side view of jammer assembly.

Points of critical stress must be evaluated so that design corrections can be made where margins of safety within any of the jammer elements appear to be unacceptably low.

On the other hand, due to a weight limitation imposed on the program, there is also a need to reduce the system weight wherever possible. Therefore, where stresses are extremely low or margins of safety are relatively high, the design should be changed to reduce element sizes.

2. DESCRIPTION OF THE NASTRAN MODEL

To evaluate those areas which are either critically stressed or overdesigned, a finite element NASTRAN model of a jammer unit was developed and exercised with loads anticipated during launch (setback) and landing conditions. Two limits were placed on the NASTRAN model configuration. First, the model had to be of sufficient detail to provide stress recovery on loads at critical points within the jammer model. This necessitated the use of a relatively large number of grid points to define each of the components within the jammer model system. However, the second constraint, which limits the number of grid points and degrees of freedom in the model, is the practical turnaround time on the computer, coupled with the disk space available to store the large matrices required.

Configurations with 620, 572, and 502 grid points were all developed. The two larger models were found not to be practical due to excessive disk storage requirements. The configuration with 502 grid points was used in the analysis.

Various views of the overall model are shown in Figures 2 to 5. The model consists of six levels of grid points, as shown in Figures 6 to 11.

Level 1 (grid points 101 to 195) corresponds to the base plate, level 2 (grid points 201 to 295) to the power pack, levels 3 (grid points 301 to 395) and 4 (grid points 401 to 480) to the bottom and top circuit boards in the electronic assembly, level 5 (grid points 501 to 580) to the insert, and level 6 (grid points 601 to 695) to the top cover.

Levels 1, 2, 3, and 6 were modeled with quadrilateral and triangular plate elements. The IDs for these elements are indicated in Figure 12. On Level 1, the thickness of the

plate elements was adjusted to account for the undercut annular region, which contains explosive material. CBAR elements (901 to 924) were used to model the lip around the perimeter of the base plate.

The power pack on level 2 was modeled as a honeycomb plate 1 inch deep with Epon 815 face sheets 0.05 inches thick.

The RF printed circuit board on level 3 was also modeled as a plate. The thickness of the plate varied to account for the saddle support. The antenna saddle tied into level 3 at grid points 371 and 381, and the antenna post tied in at grid points 371 and 393.

The plate elements for both levels 2 and 3 connected directly into the sleeve, since there appeared to be a strong shear tie between the elements at these levels and the sleeve.

At level 6, the cover was modeled as a homogeneous plate. The top of the antenna saddle support was attached to the cover at grid points 682 and 686 with a rigid bar connection, as was the antenna post at grid point 688. The body was modeled with CBAR elements (925 to 948) around the perimeter of the cover.

In fact, the cover attaches to the body at only four points, each 90° apart. Likewise, the body attaches to the sleeve at four points, also 90° apart and midway between the body-cover connections. Depending on how these parts are seated, local stress buildups can occur. To quantify this possibility, two distinct models of the jammer were developed. In the first, one set of grid points (601 to 624) was used for the sleeve, body, and cover. This assumes good stress transfer through these elements.

In the second model, twenty new grid points were defined for the body (6011 to 6241) and twenty new grid points were defined for the cover (6010 to 6240). These grid points were superimposed over the existing grid points (601 to 624) used

for the sleeve. In these models, stress from the sleeve could be transferred to the body through only four grid points (601, 607, 613, and 619) and from the body to the cover through four grid points (604, 610, 616, and 622).

The timer circuit board at level 4 and the insert at level 5 were both modeled with CROD (axial bar) elements. These are shown in Figure 13. The locations of the grid points as they fall on the drawings of the actual parts are shown in Figures 14 and 15. These elements assume that the parts offer negligible bending resistance compared with the filler material under axial load. The elements are also tied to the sleeve through CROD elements which offer lateral stability to these levels. They assume that there is a negligible shear connection with the sleeve.

The sleeve itself was modeled with quadrilateral plate elements (CQUAD4s 701 to 824). A developed view of the sleeve is shown in Figure 16. The thickness of plate elements was 0.225 inches under the vanes and 0.307 inches elsewhere. The effect of the vanes was modeled by placing concentrated mass elements (CONM2s 601 to 624) at the grid points corresponding to the vane attachments. In this model the undercut area near the vane and the reduced wall thickness of the vane attachment itself were not modeled.

The grid points at each level were connected to those grid points at the levels above and below it through vertical CROD elements, as shown in the overall views, Figures 3 and 4. These rod elements allow for transfer of stress through the model from base plate to cover plate. The total area of the plates was equitably distributed among the various rod elements. Elements 1125 to 1195 represent the power pack between levels 2 and 3; elements 1325 to 1380 represent the foam between levels 3 and 4; elements 1425 to 1480 represent the foam between

levels 4 and 5; and elements 1525 to 1580 represent the fiberglass insert between levels 5 and 6.

The antenna and antenna post were modeled with CBAR elements (1 to 16), as shown in Figure 17. The antenna was rigidly attached to both the RF printed circuit board at level 3 and the cover at level 6. The antenna post was also attached to the appropriate grid points at these two levels.

The mass of the electronics on the circuit boards was modeled with concentrated mass elements (CONM2s 555 to 569).

Finally, care was taken so that no plate element in the model had an aspect ratio worse than 2:1.

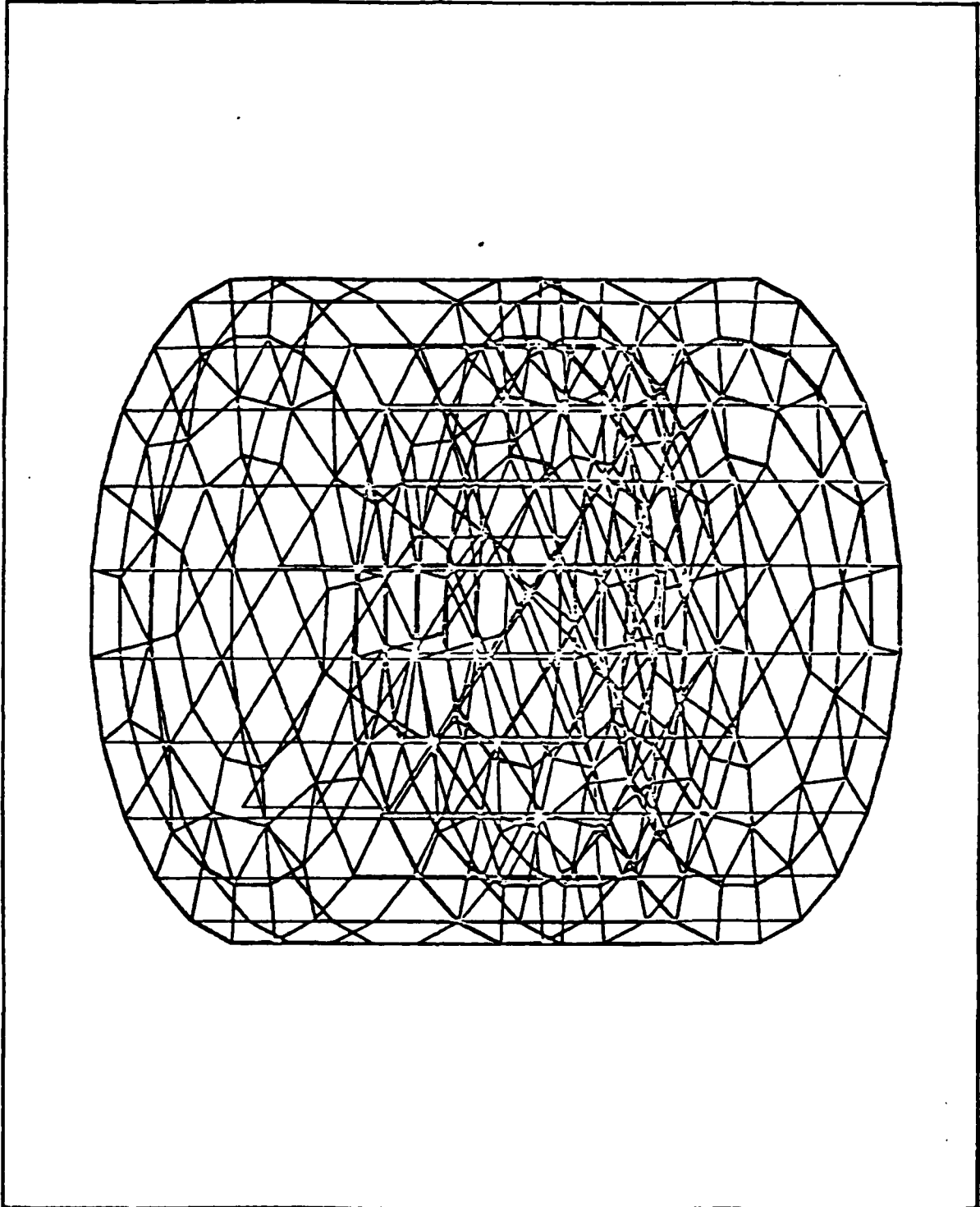

Y-Z UJEU ALL ELEMENTS PLOTTED
ALPHA= 0.000000E+00 BETA= 25.00000 GAMMA= 38.00000

Figure 2. Overall view of UEJ model (502 grid points).

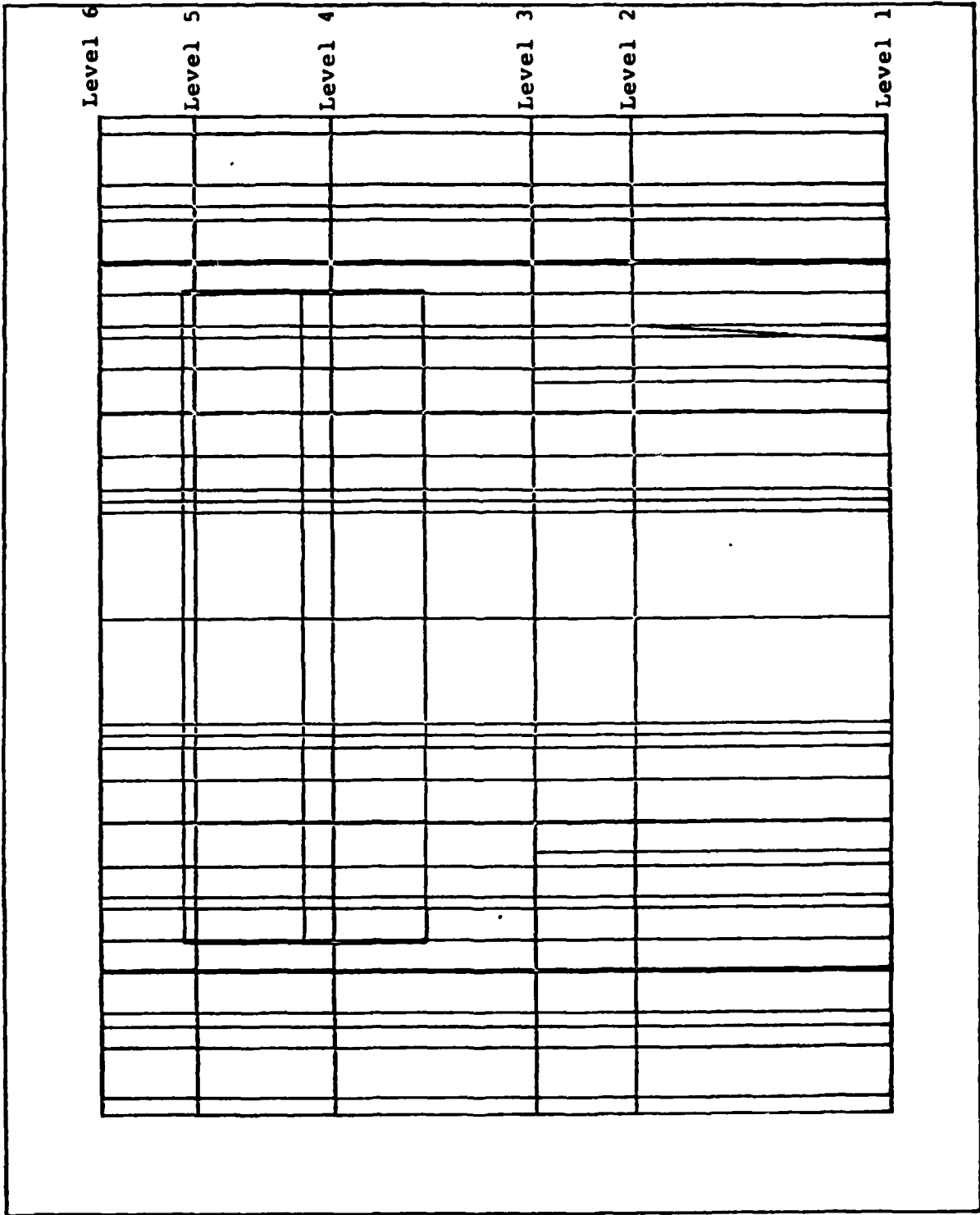

X-Z VIEW ALL ELEMENTS PLOTTED

ALPHA= 0.000000E+00 BETA= 0.000000E+00 GAMMA= 0.000000E+00

Figure 3. x-z view of UEJ model.

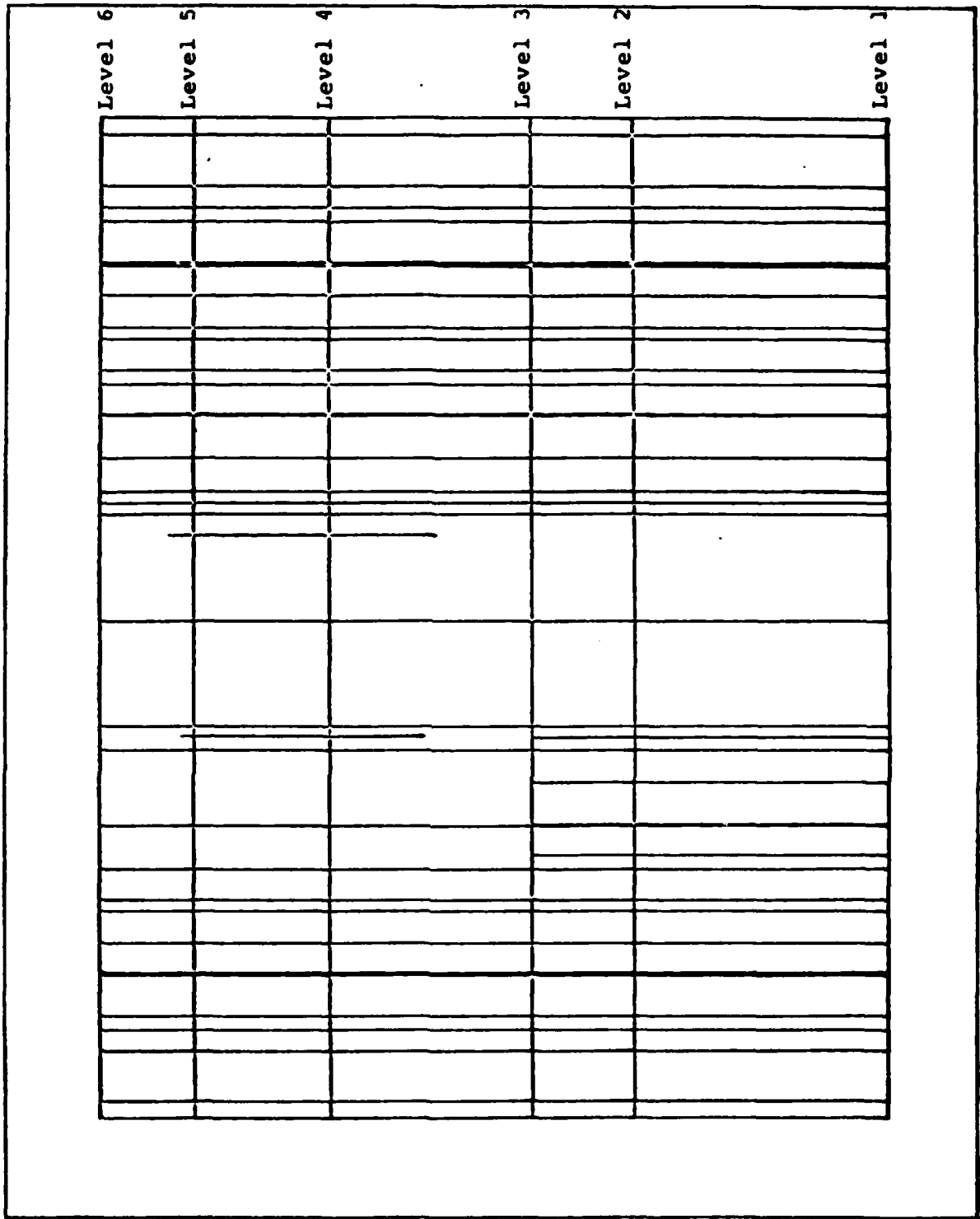

Y-Z VIEW ALL ELEMENTS PLOTTED
 ALPHA= 0.000000E+00 BETA= 0.000000E+00 GAMMA= 0.000000E+00

Figure 4. y-z view of UeJ model.

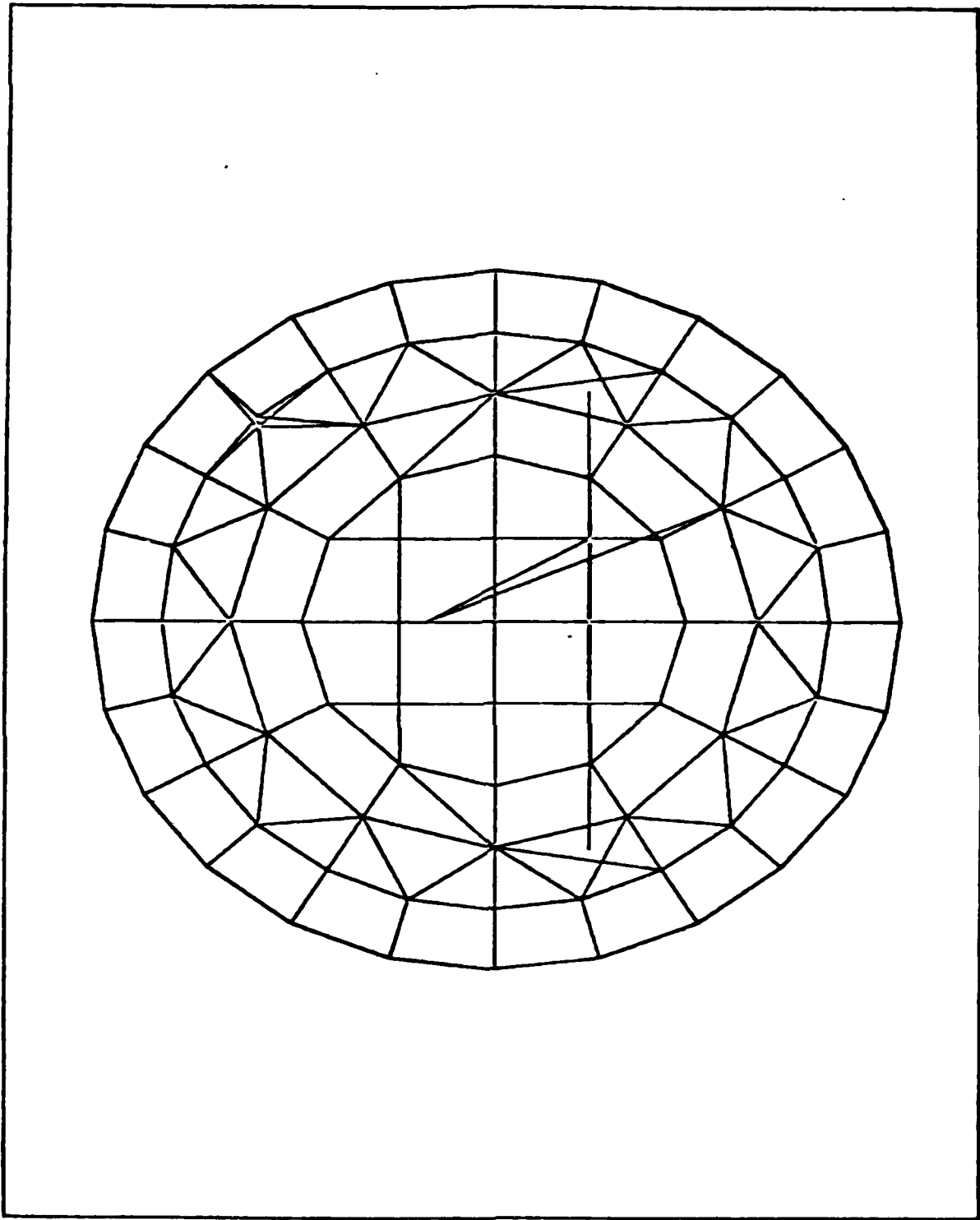

X-Y VIEW ALL ELEMENTS PLOTTED
ALPHA= 0.000000E+00 BETA= 0.000000E+00 GAMMA= 0.000000E+00

Figure 5. x-y view of UEJ model.

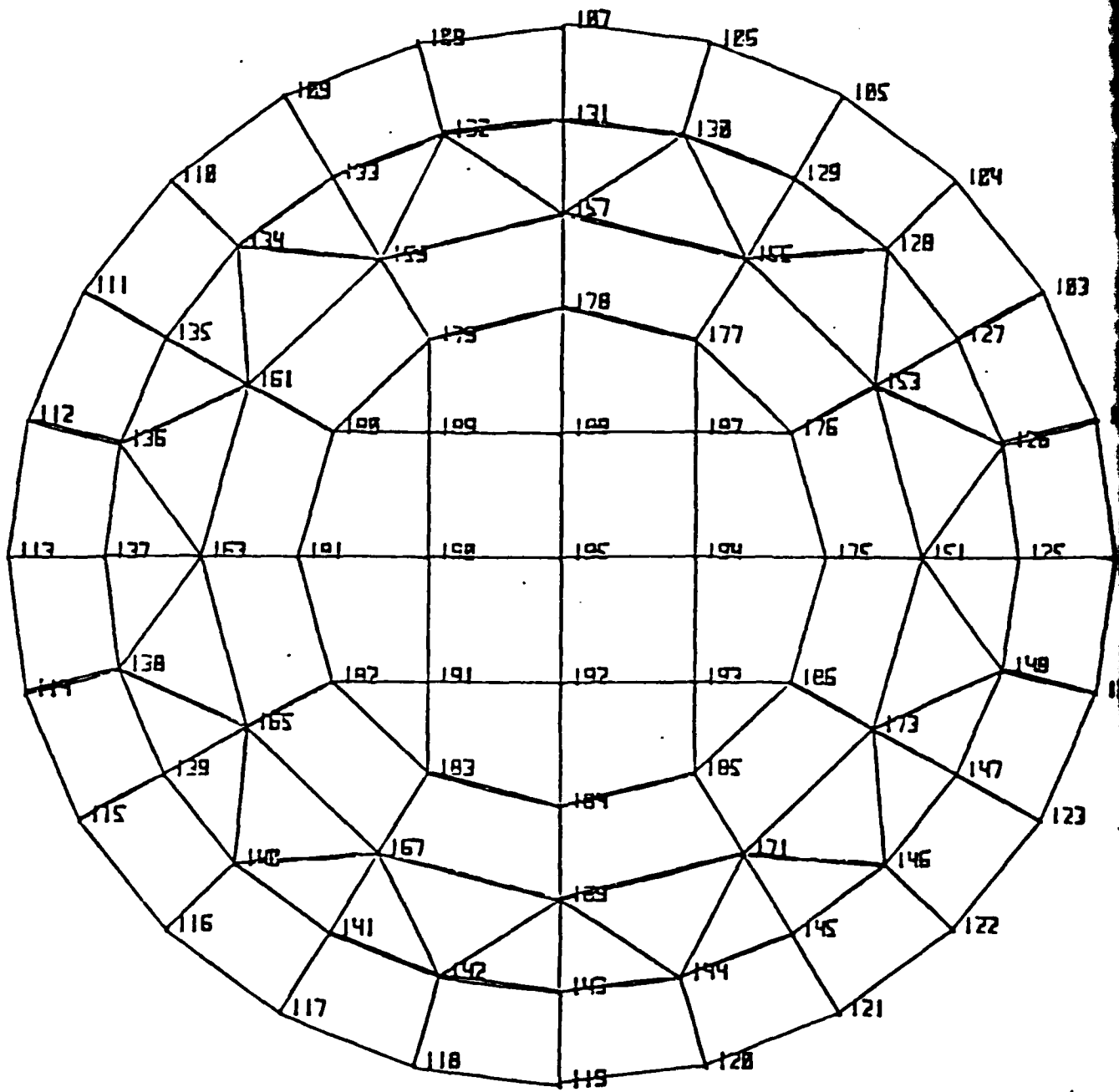

Figure 6. Level 1 with grid points labeled.

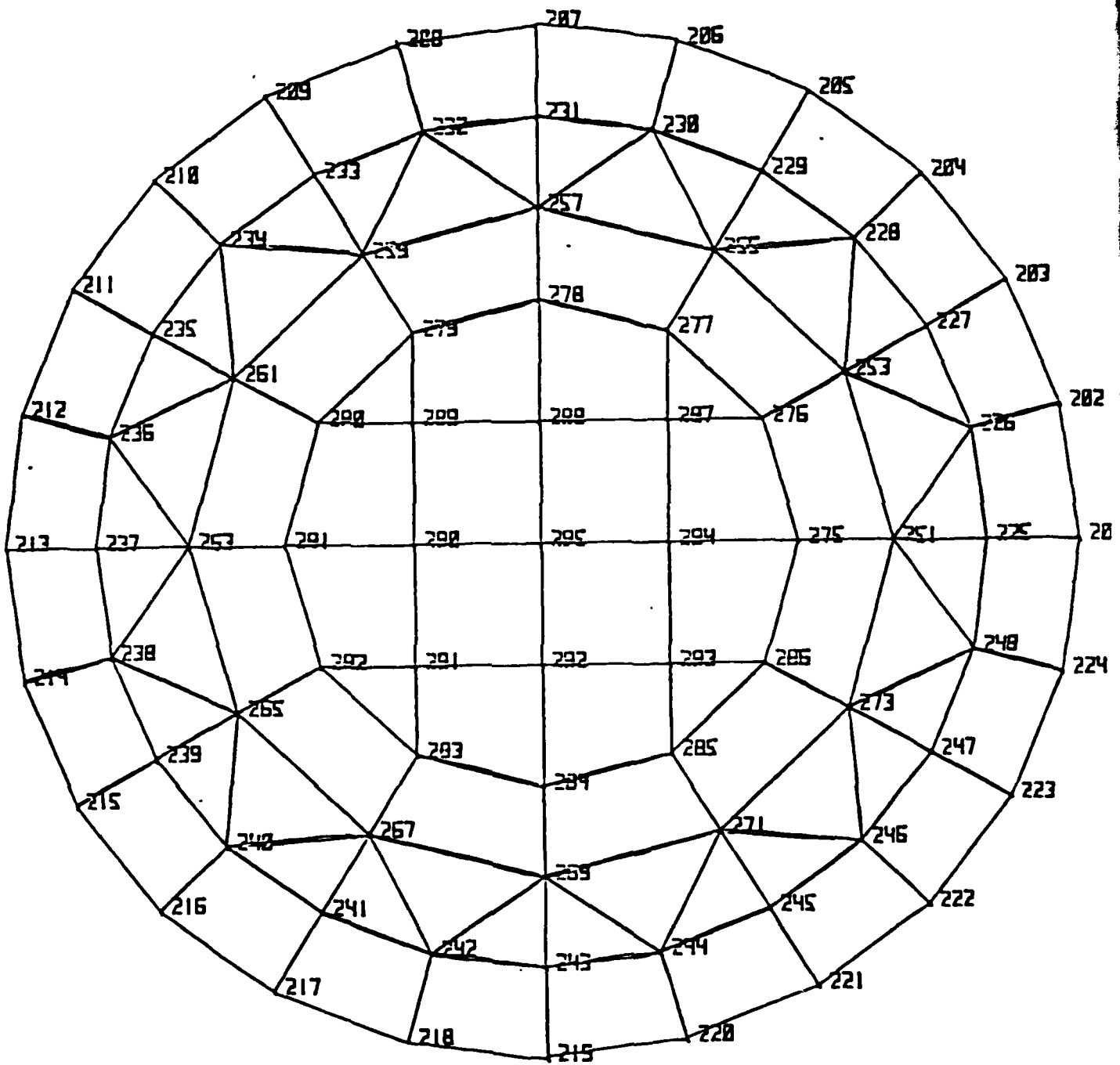

Figure 7. Level 2 with grid points labeled.

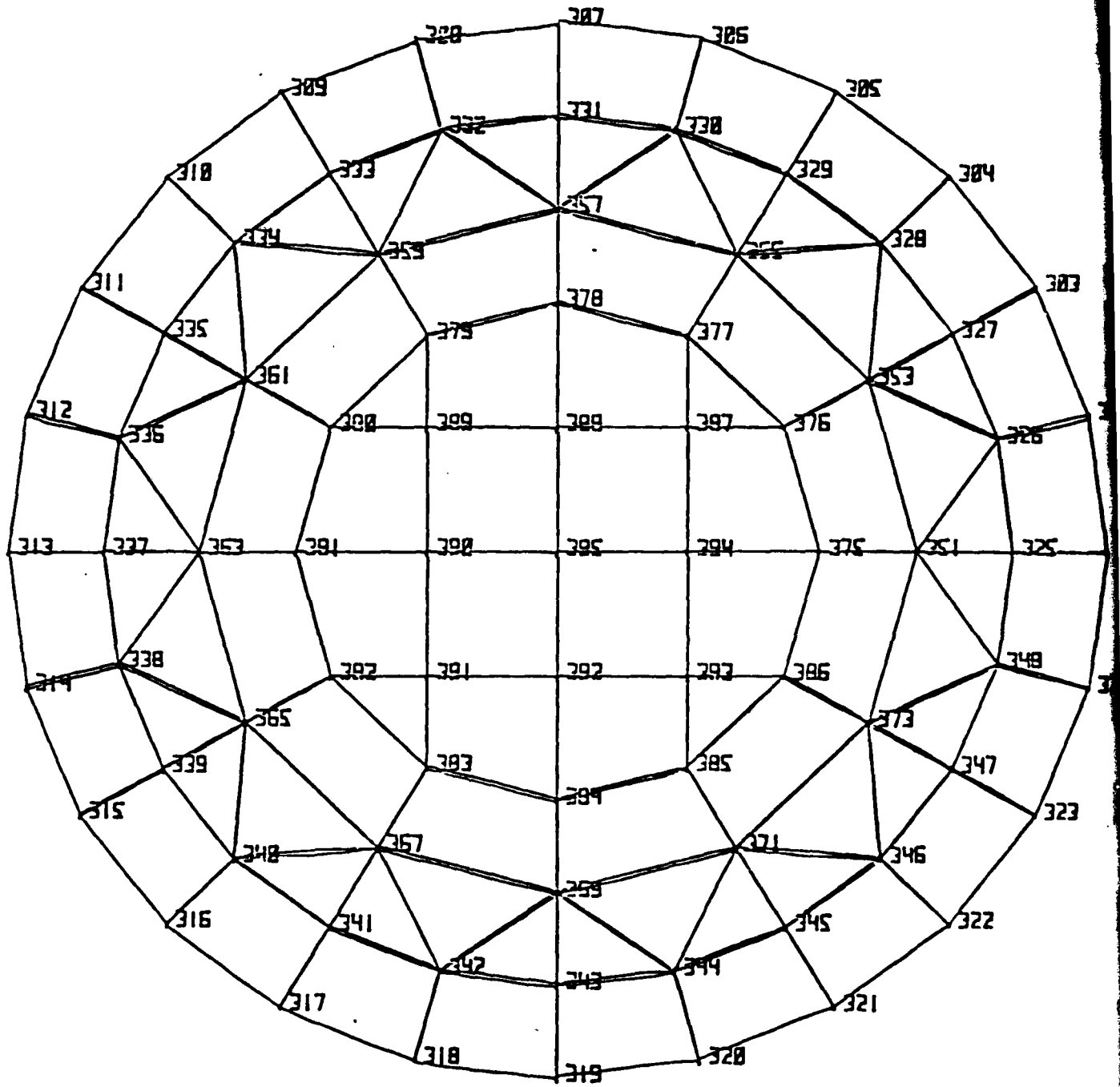

Figure 8. Level 3 with grid points labeled.

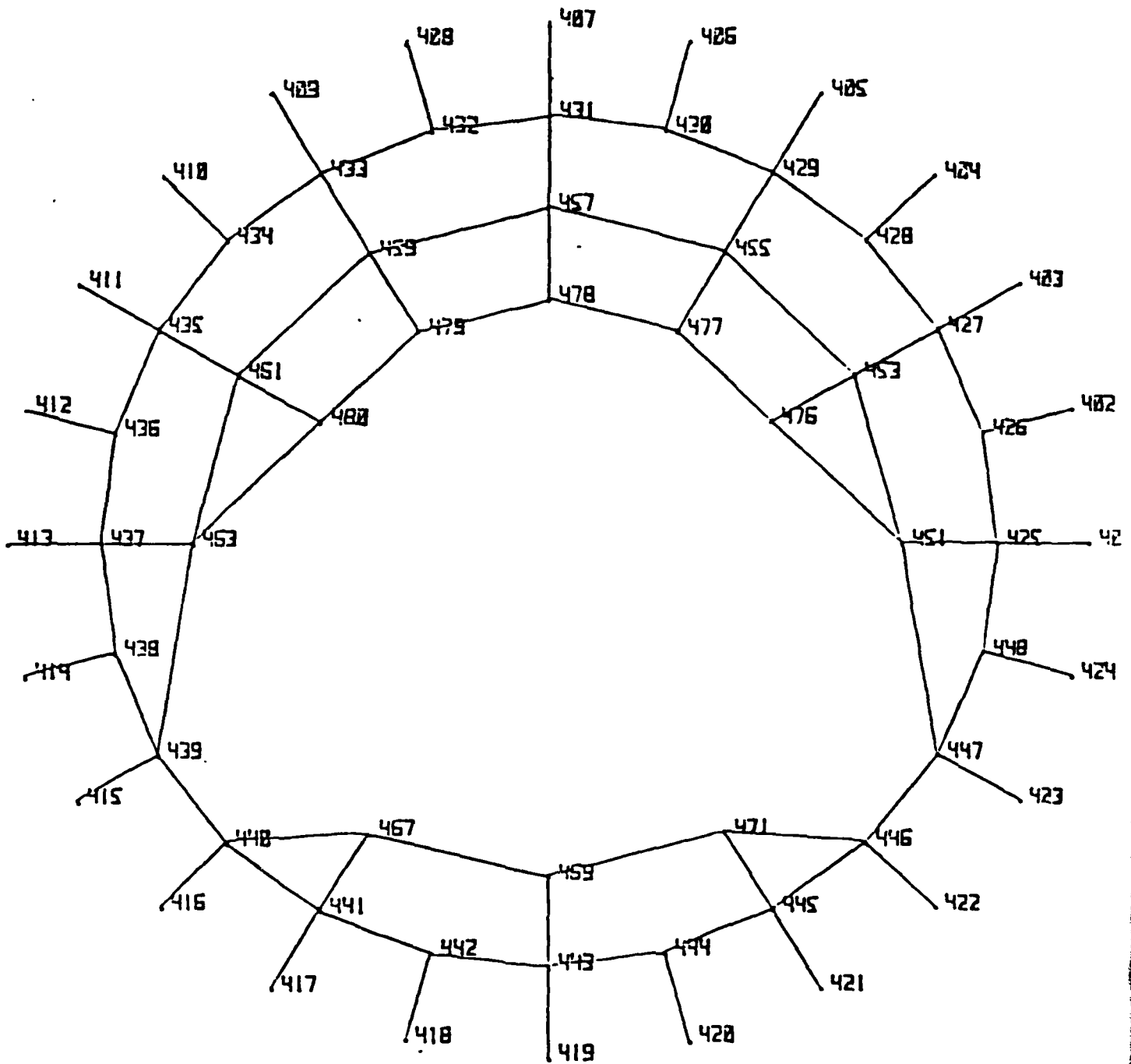

Figure 9. Level 4 with grid points labeled.

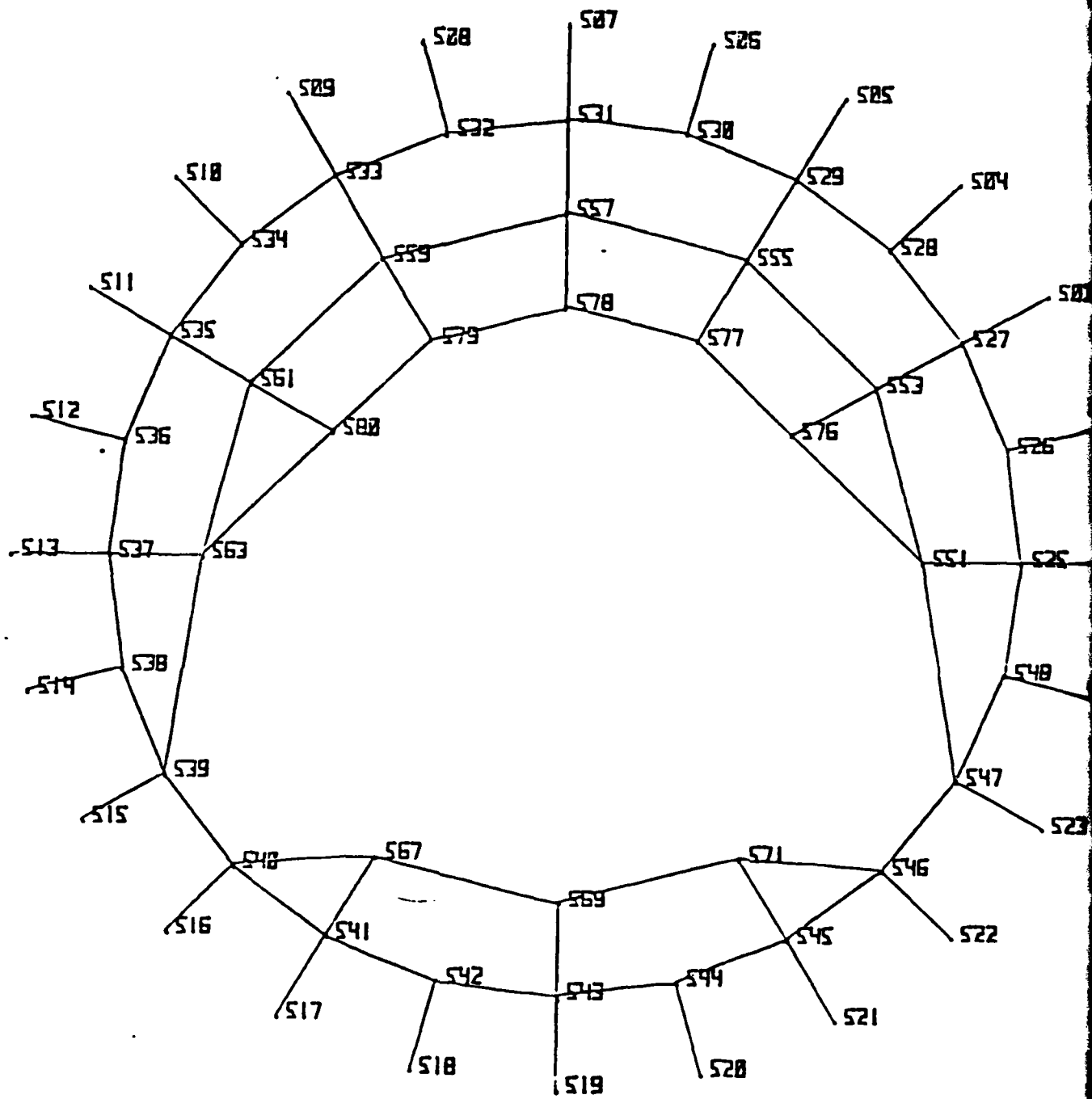

Figure 10. Level 5 with grid points labeled.

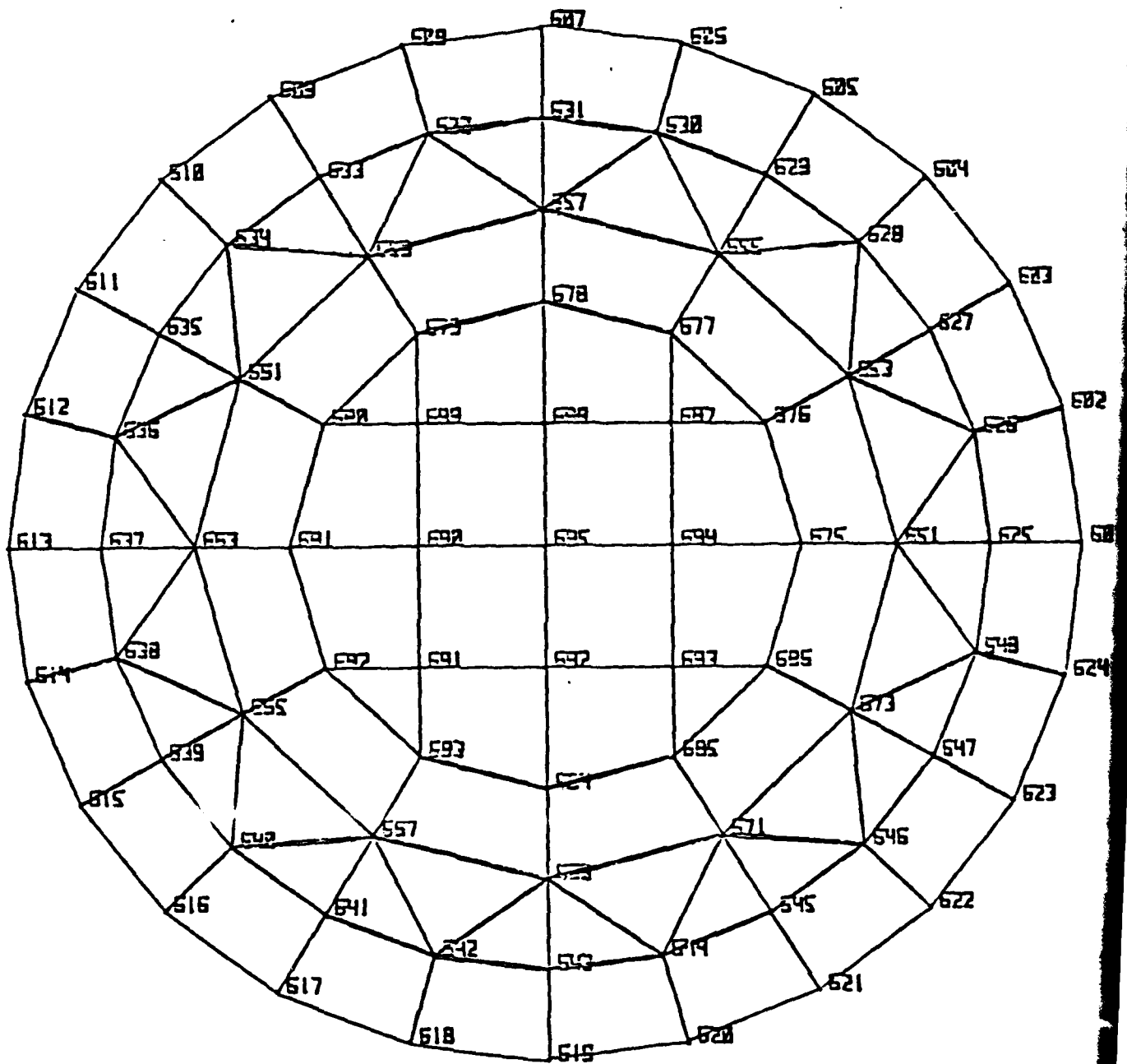

Figure 11. Level 6 with grid points labeled.

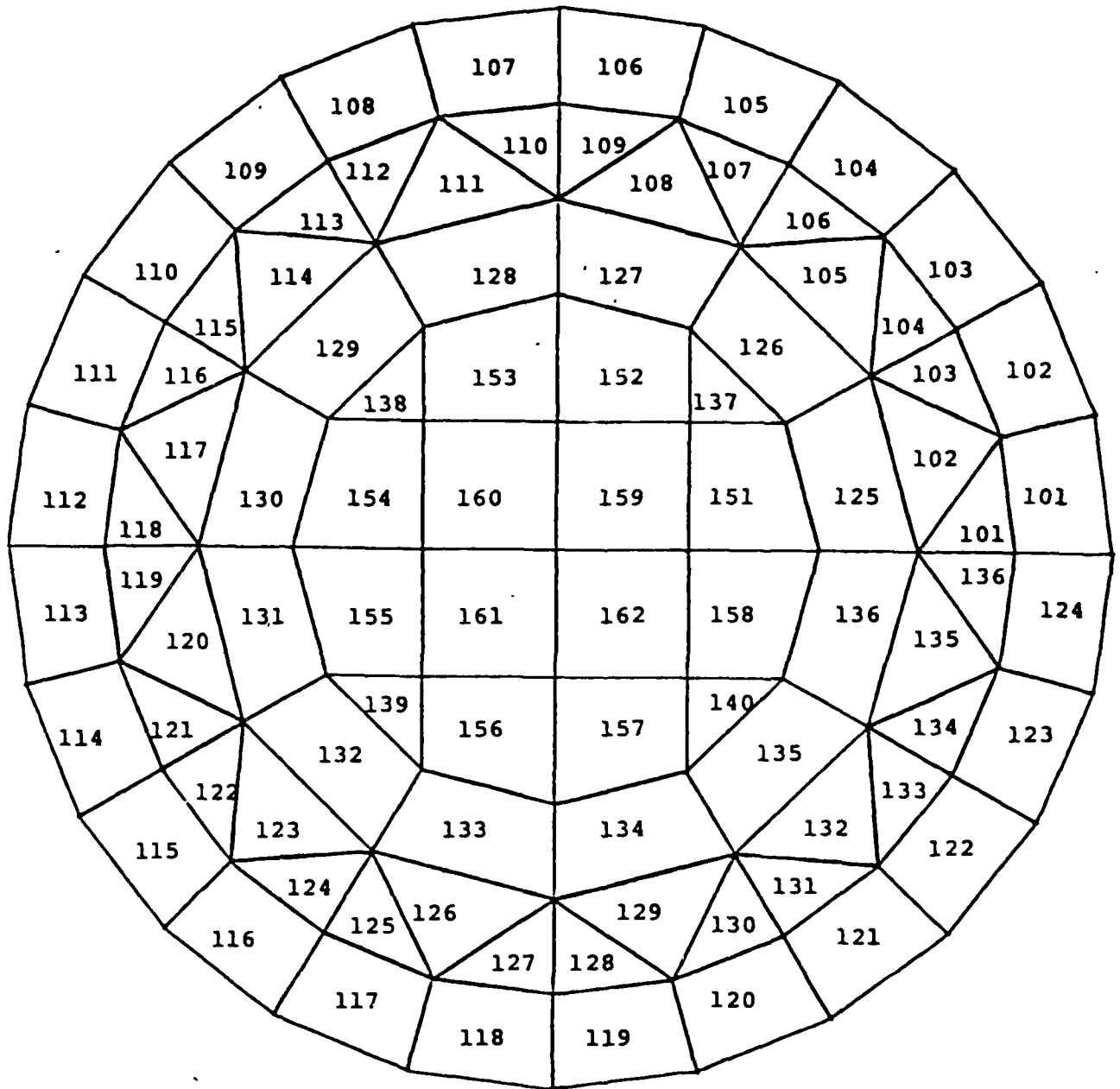

Figure 12. Level 1 quadrilateral and triangular plate element ID's. Levels 2, 3 and 6 are analogous in the 200, 300 and 400 series, respectively.

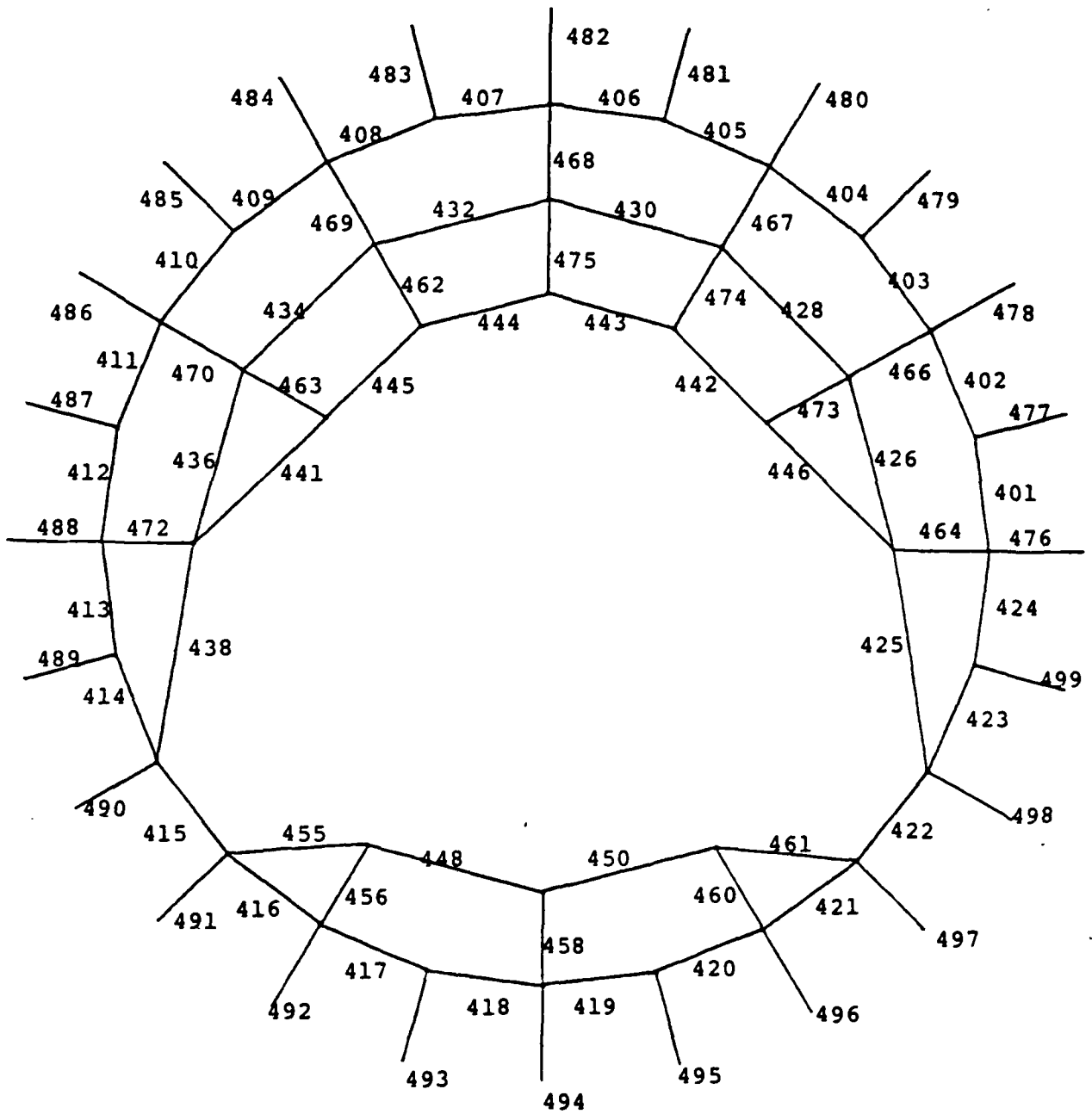

Figure 13. Level 4 CROD element ID's. Level 5 is analagous in the 500 series.

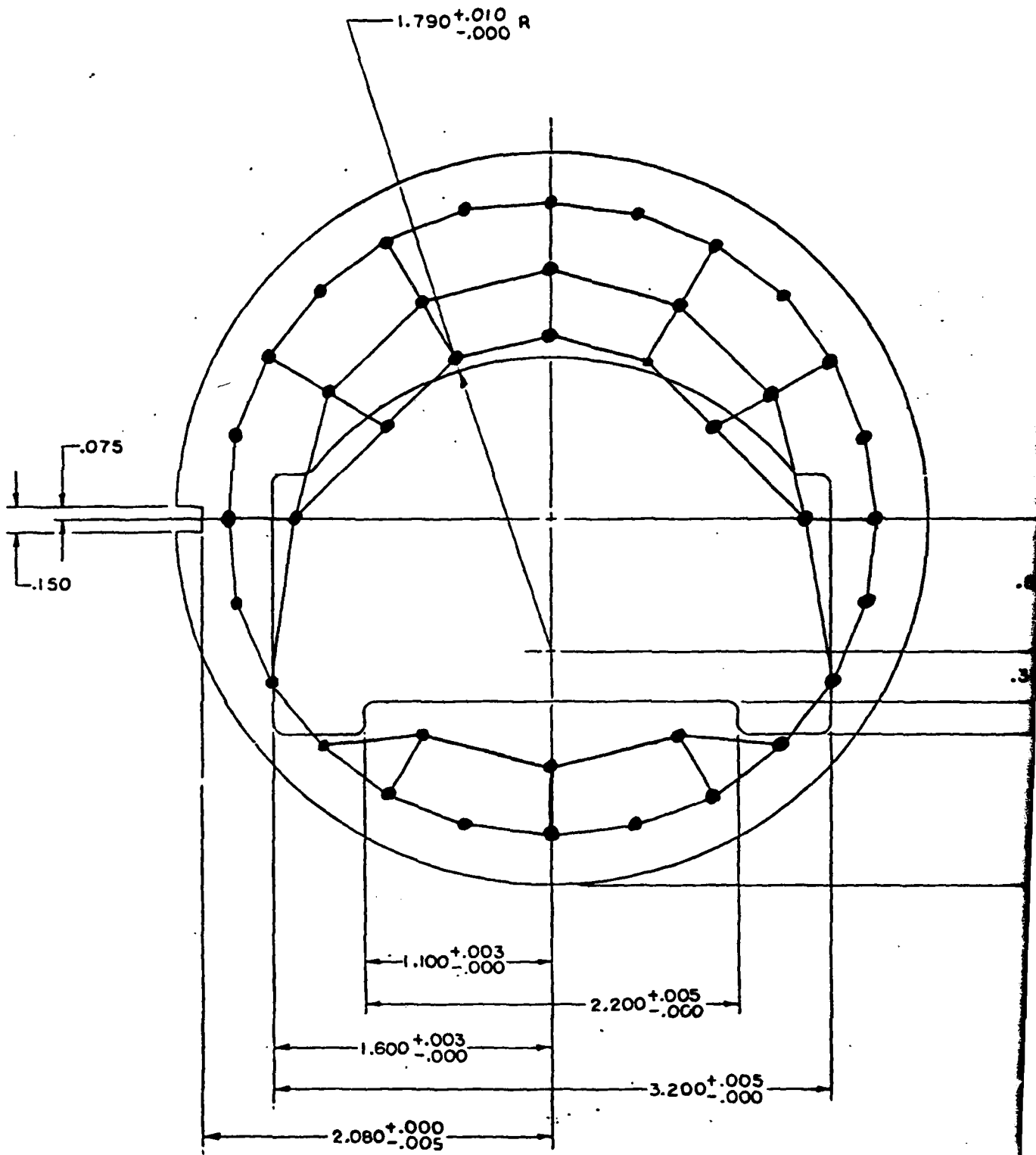

Figure 14. NASTRAN model of Timer Printed Circuit Board superimposed over drawing of actual hardware.

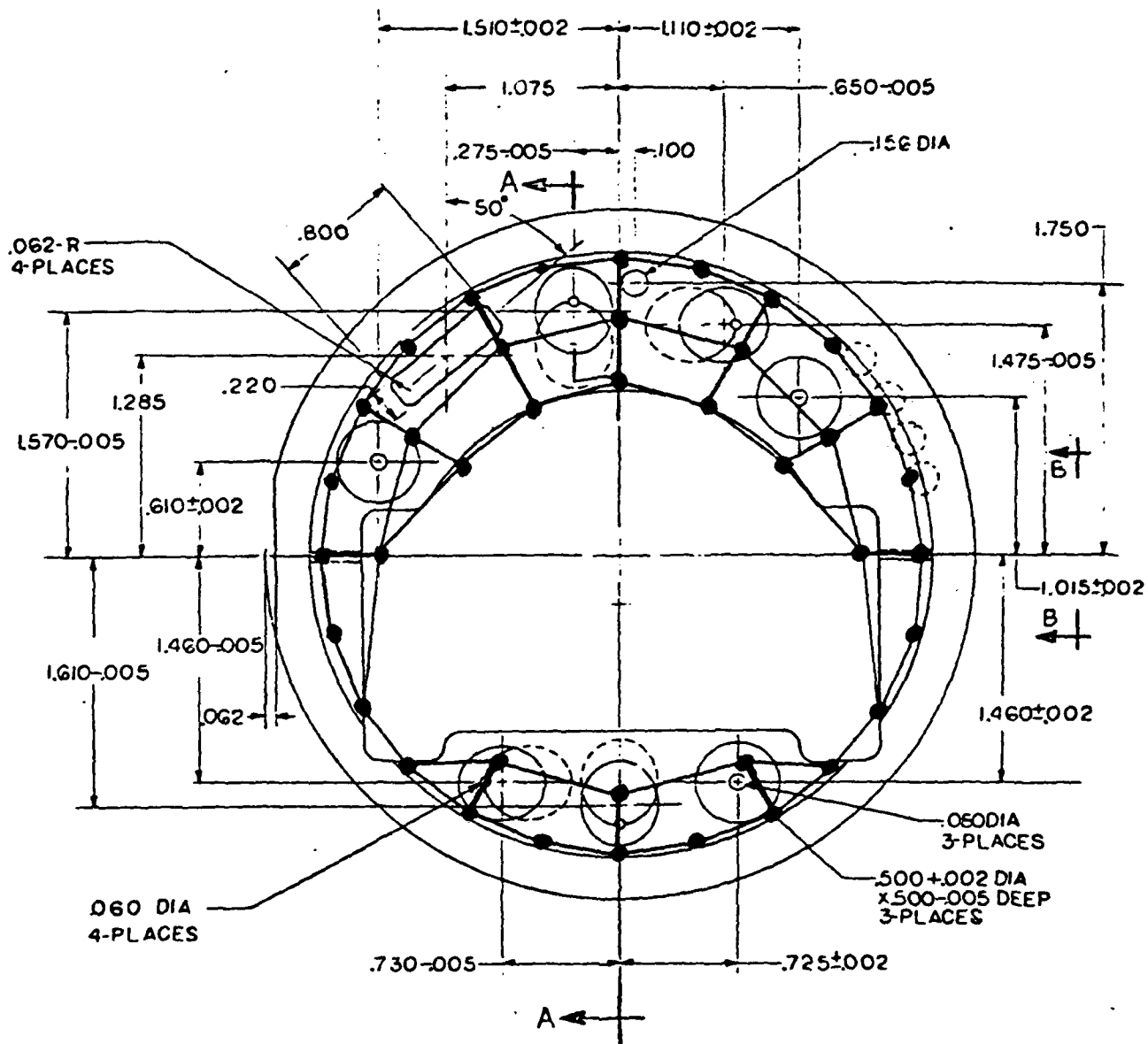

Figure 15. NASTRAN model of Insert superimposed over drawing of actual hardware.

1. Quadrilateral plate element IDs are labeled;
2. IDs of grid points in lower left corners of each plate element are the same numbers as plate IDs.
3. Shaded areas correspond to vane locations.

801	802	803	804	805	806	807	808	809	810	811	812	813	814	815	816	817	818	819	820	821	822	823	824
775	776	777	778	779	780	781	782	783	784	785	786	787	788	789	790	791	792	793	794	795	796	797	798
751	752	753	754	755	756	757	758	759	760	761	762	763	764	765	766	767	768	769	770	771	772	773	774
725	726	727	728	729	730	731	732	733	734	735	736	737	738	739	740	741	742	743	744	745	746	747	748
701	702	703	704	705	706	707	708	709	710	711	712	713	714	715	716	717	718	719	720	721	722	723	724
----- LEVEL 6 -----																							
----- LEVEL 5 -----																							
----- LEVEL 4 -----																							
----- LEVEL 3 -----																							
----- LEVEL 2 -----																							
----- LEVEL 1 -----																							

Figure 16. Developed view of sleeve.

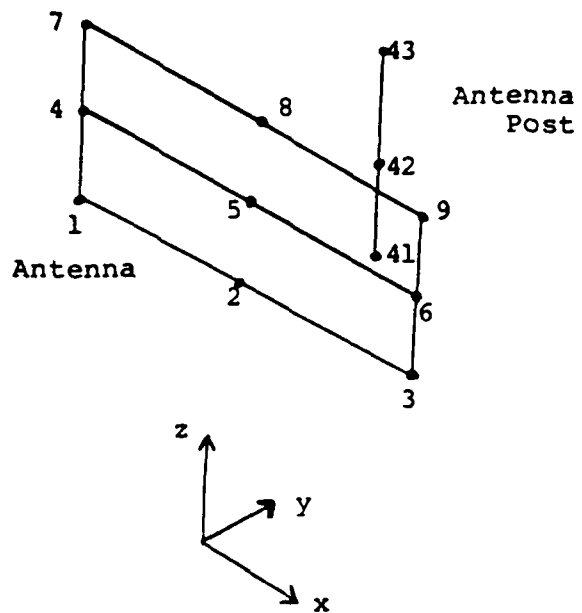

Figure 17. CBAR model of antenna and antenna post with grid points labeled.

3. SUMMARY OF RESULTS FOR STATIC ANALYSIS

There are two versions of the NASTRAN program: COSMIC NASTRAN, available at Harry Diamond Laboratories, and MacNeal-Schwendler (MSC) NASTRAN, available to Mega Engineering. MSC NASTRAN has a superior quadrilateral plate element (CQUAD4) because it combines into one isoparametric element both bending and membrane stresses. COSMIC NASTRAN requires both the CQDPLT element for bending and the CQDMEM1 element for membrane stresses. Furthermore, MSC NASTRAN has a grid point force balance as standard output which summarizes the forces at each grid point for each element which connects there. All production runs for static analysis were run on both MSC and COSMIC NASTRANS, but the output from the MSC version is presented here. Results were, of course, substantially the same for both versions.

The NASTRAN model generated a weight of 8.3 lbs for a UEJ unit. This was slightly higher than the 8 lbs predicted by hand analysis at HDL. The center of gravity was found to be 1.82 inches above the bottom of the base plate, 0.003 inches along the x axes, and -0.024 inches along the y axes from the geometric center of the sleeve. I_{xx} was found to be 29.1 in.-lbs, I_{yy} was 29.3 in.-lbs, and I_{zz} was 34.1 in.-lbs. These results all compared very favorably with the hand analyses.

As described in section 2, the body attaches to the sleeve at only four points and the cover attaches to the body at four other points. If there are local defects in these parts causing them not to seat together properly, local stress concentrations may arise. This condition was modeled by defining a separate set of grid points for each part: the sleeve, the cover, and the body.

A total of four subcases were run. In each case, a load of 1000 g's in the axial direction was applied to the model. In subcase 1 this load was reacted at the cover plate (Level 6), which represented the gunfire or setback condition. Furthermore, 40 pounds of mass was distributed around the perimeter of the sleeve at the base. This weight represented the compressive force the five remaining jammers exert on the bottom jammer when the shell is fired (the setback condition). The jammer should be designed with a lip on the base to insure that, in the stack-up, all load is transmitted from one to the other through the sleeve, and not from the cover of one to the base plate of the other. This latter condition would be very difficult to analyze. This subcase also has one set of grid points common to the body, sleeve, and cover, thus assuming they all seat-out well. Peak stresses for each type of element in the jammer are presented in Table 1, and peak axial displacements at each level are presented in Table 5.

In subcase 2, the 1000 g axial load was reacted at the base plate (Level 1), which represented the landing of ground impact of the UEJ. Again there was one set of grid points common to the body, sleeve, and cover. Peak stresses are presented in Table 2 and peak displacements in Table 6. We see from a comparison with the previous subcase that this is the less severe condition.

Subcase 3 is analogous to Subcase 1, and Subcase 4 is analogous to Subcase 2, except for the model of the sleeve, body, and cover junction. Results for Subcase 3 are presented in Tables 3 and 7, and for Subcase 4 in Tables 4 and 8. We see from these tables that very large stresses can build up in both the sleeve and body for these subcases and that care must be taken in the design of the jammer so that this condition does not occur.

The deflections for these subcases at the various levels appear small. However, many of the components (e.g., power pack case) are brittle and can fracture. A further analysis of this problem is required.

Stresses in the base plate are largest in the annular region, which is thinner than the center of the plate. Some weight may be saved by undercutting the center of the base plate. The strength of this plate is determined by a thinner annular region, and no particular advantage is gained by making the central region thicker.

A short circular cylindrical structure with thick walls subjected to a compressive load acting parallel to its axis fails when the stresses pass the ultimate compressive strength of the material. This is a typical material failure and is only a function of the mechanical properties of the material. However, when the cylinder is long and the walls are relatively thin, failure by buckling may occur.

The critical stress at which this buckling occurs is classically given¹ by the formula:

$$\sigma_{cr} = \{Et/R\}/\{3(1-\nu^2)\}^{1/2}$$

where σ_{cr} is the critical buckling stress, t is the cylinder wall thickness, R is the cylinder radius, E is Young's modulus and ν is Poisson's ratio. Assuming that $t = 0.225$, $E = 29,000,000$, $R = 2.363$, and $\nu = 0.32$, we find that the critical stress for buckling is 1,680,000 psi. Obviously, plastic deformation will occur long before this critical stress is approached.

¹D. O. Brush and B. O. Almruth, Buckling of Bars, Plates and Shells, McGraw-Hill, (1975).

TABLE 1. SUBCASE 1: SETBACK - PEAK STRESSES IN UNATTENDED EXPENDABLE JAMMER FOR 1000 g LOAD IN AXIAL DIRECTION

Computer Run: YMJTYCOV (April 7, 1980)

Constraint Conditions: SPC'd at Level 6 (cover) in x, y and z directions. Note: 40 lbs of mass was added to perimeter of base plate to model compressive force of the five remaining jammers.

Body, Sleeve, and Cover Model: one set of grid points common to all.

Peak Stresses

UEJ Part	Element Type	Element ID Range	Element ID with Peak Stress	Peak Stress (psi)
Base Plate	CQUAD4	101-162	126	9,860
Power Pack	"	201-262	259	434
RF PCB	"	301-362	313	896
Cover	"	601-662	623	-12,100
Sleeve	"	701-824	822	-17,200
Base Plate	CTRIA2	101-140	136	9,930
Power Pack	CTRIA1	201-240	237	120
RF PCB	CTRIA1	301-340	331	886
Cover	CTRIA2	601-640	638	6,790
Antenna	CBAR	1-16	13	-5,190
Lip on Lower Sleeve	"	901-924	901	2,240
Body	"	925-948	939	1,140
Power Pack	CROD	1125-1195	1145	56
Foam Level 2-3	"	1225-1295	1295	31
Foam Level 3-4	"	1325-1381	1343	15
Foam Level 4-5	"	1425-1481	1443	-30
Fiberglass Insert	"	1525-1581	1555	-73

TABLE 2. SUBCASE 2: GROUND IMPACT - PEAK STRESSES IN UN-ATTENDED EXPENDABLE JAMMER FOR 1000 g LOAD IN AXIAL DIRECTION

Computer Run: YMJTYBOT (April 7, 1980)

Constraint Conditions: SPC'd at Level 1 (Bottom Plate) in x, y, and z directions.

Body, Sleeve, and Cover Model: one set of grid points common to all.

Peak Stresses

UEJ Part	Element Type	Element ID Range	Element ID with Peak Stress	Peak Stress (psi)
Base Plate	CQUAD4	101-162	126	10,200
Power Pack	"	201-262	259	354
RF PCB	"	301-362	330	679
Cover	"	601-662	631	12,000
Sleeve	"	701-824	814	6,400
Base Plate	CTRIA2	101-140	104	11,100
Power Pack	CTRIA1	201-240	237	35
RF PCB	CTRIA1	301-340	330	-427
Cover	CTRIA2	601-640	638	7,240
Antenna	CBAR	1-16	7	-739
Lip on Lower Sleeve	"	901-924	917	888
Body	"	925-948	946	2,560
Power Pack	CROD	1125-1195	1145	101
Foam Level 2-3	"	1225-1295	1271	34
Foam Level 3-4	"	1325-1381	1343	101
Foam Level 4-5	"	1425-1481	1476	-19
Fiberglass Insert	"	1525-1581	1555	-64

TABLE 3. SUBCASE 3: SETBACK - PEAK STRESSES IN UNATTENDED EXPENDABLE JAMMER FOR 1000 g LOAD IN AXIAL DIRECTION

Computer Run: YMJTYTOP (April 7, 1980)

Constraint Conditions: SPC'd at Level 6 (Body) in x, y, and z directions. Note: 40 lbs of mass was added to perimeter of base plate to model the compressive force of the five remaining jammers.

Body, Sleeve, and Cover Model: three sets of grid points - a separate set for each structure.

Peak Stresses

UEJ Part	Element Type	Element ID Range	Element ID with Peak Stress	Peak Stress (psi)
Base Plate	CQUAD4	101-162	134	12,000
Power Pack	"	201-262	262	520
RF PCB	"	301-362	321	1,990
Cover	"	601-662	632	-26,100
Sleeve	"	701-824	824	-62,800
Base Plate	CTRIA2	101-140	127	-12,900
Power Pack	CTRIA1	201-240	214	220
RF PCB	CTRIA1	301-340	330	1,940
Cover	CTRIA2	601-640	621	20,800
Antenna	CBAR	1-16	12	273
Lip on Lower Sleeve	"	901-924	913	3,090
Body	"	925-948	939	25,900
Power Pack	CROD	1125-1195	1145	92
Foam Level 2-3	"	1225-1295	1271	68
Foam Level 3-4	"	1325-1381	1331	241
Foam Level 4-5	"	1425-1481	1471	-24
Fiberglass Insert	"	1525-1581	1555	58

TABLE 4. SUBCASE 4: GROUND IMPACT - PEAK STRESSES IN UNATTENDED EXPENDABLE JAMMER FOR 1000 g LOAD IN AXIAL DIRECTION

Computer Run: YMJTYBTM (April 7, 1980)

Constraint Conditions: SPC'd at Level 1 (Bottom Plate) in x, y, and z directions.

Body, Sleeve, and Cover Model: three sets of grid points - a separate set for each structure.

Peak Stresses

UEJ Part	Element Type	Element ID Range	Element ID with Peak Stress	Peak Stress (psi)
Base Plate	CQUAD4	101-162	135	15,800
Power Pack	"	201-262	262	549
RF PCB	"	301-362	330	2,600
Cover	"	601-662	632	9,870
Sleeve	"	701-824	720	5,160
Base Plate	CTRIA2	101-140	122	17,000
Power Pack	CTRIAL	201-240	238	54
RF PCB	CTRIAL	301-340	330	1,560
Cover	CTRIA2	601-640	619	9,260
Antenna	CBAR	1-16	13	6,160
Lip on Lower Sleeve	"	901-924	920	1,310
Body	"	925-948	946	67,100
Power Pack	CROD	1125-1195	1145	186
Foam Level 2-3	"	1225-1295	1271	175
Foam Level 3-4	"	1325-1381	1343	805
Foam Level 4-5	"	1425-1481	1443	125
Fiberglass Insert	"	1525-1581	1543	113

TABLE 5. 'SUBCASE 1: SETBACK - PEAK AXIAL DISPLACEMENTS IN UNATTENDED EXPENDABLE JAMMER FOR 1000 g LOAD IN AXIAL DIRECTION

Computer Run: YMJTYCOV (April 7, 1980)

Constraint Conditions: SPC'd at Level 6 (cover) in x, y, and z directions. Note: 40 lbs of mass was added to perimeter of base plate to model compressive force of the five remaining jammers.

Body, Sleeve, and Cover Model: one set of grid points common to all.

Peak Axial Displacements

Level	Grid Point Range	Grid Point	Displacement (in.)
1	101-195	195	0.0068
2	201-295	295	0.0068
3	301-395	388	0.0057
4	401-480	478	0.0037
5	501-580	578	0.0022
6	601-695	695	0.0031
Antenna	1-43	2	0.0043

TABLE 6. SUBCASE 2: GROUND IMPACT - PEAK AXIAL DISPLACEMENTS
IN UNATTENDED EXPENDABLE JAMMER FOR 1000 g LOAD IN AXIAL DIRECTION

Computer Run: YMJTYBOT (April 7, 1980)

Constraint Conditions: SPC'd at Level 1 (Bottom Plate) in x, y,
and z directions.

Body, Sleeve, and Cover Model: one set of grid points common to
all.

Peak Axial Displacements

Level	Grid Point Range	Grid Point	Displacement (in.)
1	101-195	195	0.0060
2	201-295	288	0.0052
3	301-395	388	0.0050
4	401-480	478	0.0035
5	501-580	578	0.0025
6	601-695	695	0.0033
Antenna	1-43	2	0.0043

TABLE 7. SUBCASE 3: SETBACK - PEAK AXIAL DISPLACEMENTS IN UNATTENDED EXPENDABLE JAMMER FOR 1000 g LOAD IN AXIAL DIRECTION

Computer Run: YMJTYTOP (April 7, 1980)

Constraint Conditions: SPC'd at Level 6 (Body) in x, y, and z directions. Note: 40 lbs of mass was added to perimeter of base plate to model the compressive force of the five remaining jammers.

Body, Sleeve, and Cover Model: three sets of grid points - a separate set for each structure.

Peak Axial Displacements

Level	Grid Point Range	Grid Point	Displacement (in.)
1	101-195	195	0.011
2	201-295	295	0.011
3	301-395	395	0.010
4	401-480	478	0.0090
5	501-580	578	0.0090
6	601-695	695	0.0099
Antenna	1-43	2	0.0061

TABLE 8. SUBCASE 4: GROUND IMPACT - PEAK AXIAL DISPLACEMENTS
IN UNATTENDED EXPENDABLE JAMMER FOR 1000 g LOAD IN AXIAL DIRECTION

Computer Run: YMJTYBTM (April 7, 1980)

Constraint Conditions: SPC'd at Level 1 (Bottom Plate) in x, y,
and z directions.

Body, Sleeve, and Cover Model: three sets of grid points - a
separate set for each structure.

Peak Axial Displacements

Level	Grid Point Range	Grid Point	Displacement (in.)
1	101-195	195	0.0090
2	201-295	295	0.0089
3	301-395	390	0.0098
4	401-480	480	0.0102
5	501-580	563	0.0108
6	601-695	695	0.0117
Antenna	1-43	8	0.0122

4. SUMMARY OF EIGENVALUE ANALYSIS

When the jammer is fired, it sees an impulse load which lasts for 20 milliseconds and which peaks at several thousand g's in magnitude. If this load should excite a resonant mode in the jammer, the load felt by the jammer could be several times larger due to amplification. Furthermore, it has been established empirically that the mechanical strength of materials is measurably reduced during vibration. Thus, it is important to know the first several resonant modes in the jammer, especially in the axial direction.

Eigenvalues in NASTRAN have traditionally been determined in either of two ways, the Givens Method or the Inverse Power Method. (Note that in the current release of COSMIC NASTRAN, a third method has been introduced: FEER - Fast Eigenvalue Extraction Routine.) The Inverse Power Method is an iterative method and is most advantageous when only a few modes in a narrow frequency band are desired. The Givens Method is most practical when several modes over a wide frequency range are desired, and it is the method that was used for this report.

The Givens Method uses the fact that far fewer degrees of freedom are required in a model to characterize its modal response than to characterize its static response. Engineering judgment is required to place selected degrees of freedom (usually no more than 200) in an analysis set. Eigenvalues are then found for each of these degrees of freedom. Typically, only translational and not rotational degrees of freedom are chosen. Representative grid points are chosen from throughout the model, especially those points with large mass or which intuitively contribute to the fundamental modes. Figure 18 shows the degrees of freedom from level 1 which were placed in the analysis set.

From all the modes found by NASTRAN, it is natural to ask, "Which modes are the most significant?" Some low frequency modes may represent only local motion and may not contribute to the overall structural response. For each mode, NASTRAN computes a generalized mass and a generalized stiffness. These terms, together with the sum of the forces of single point constraint in each direction for each mode, may be combined to compute a quantity called the modal participation factor. This factor in turn may be used to compute the apparent weight of the structure for each mode and for each direction. The sum of the apparent weights for each direction totals the total weight generated by the model. Modes with large apparent weights contribute more significantly to the total structural response than do other modes.

A modal analysis of the jammer was performed for both launch (setback) and landing conditions. Since the axial response is primarily of concern, mostly z directional degrees of freedom were placed in the analysis set. The results for the launch condition are shown in Table 9. The first significant mode in the z-direction occurs at 1021 Hz and corresponds to an excitation of the antenna. The first breathing mode of the jammer occurs at 1575 Hz. The periods for both of these frequencies are short compared to the duration of the load/impulse and, therefore, little gain can be anticipated.

From Table 10 we see that the first mode for the landing condition is a breathing mode of the base plate and occurs at 1861 Hz. Likewise, little gain can be anticipated for this case.

x = degrees of freedom x, y and z in analysis set
 o = degree of freedom z in analysis set

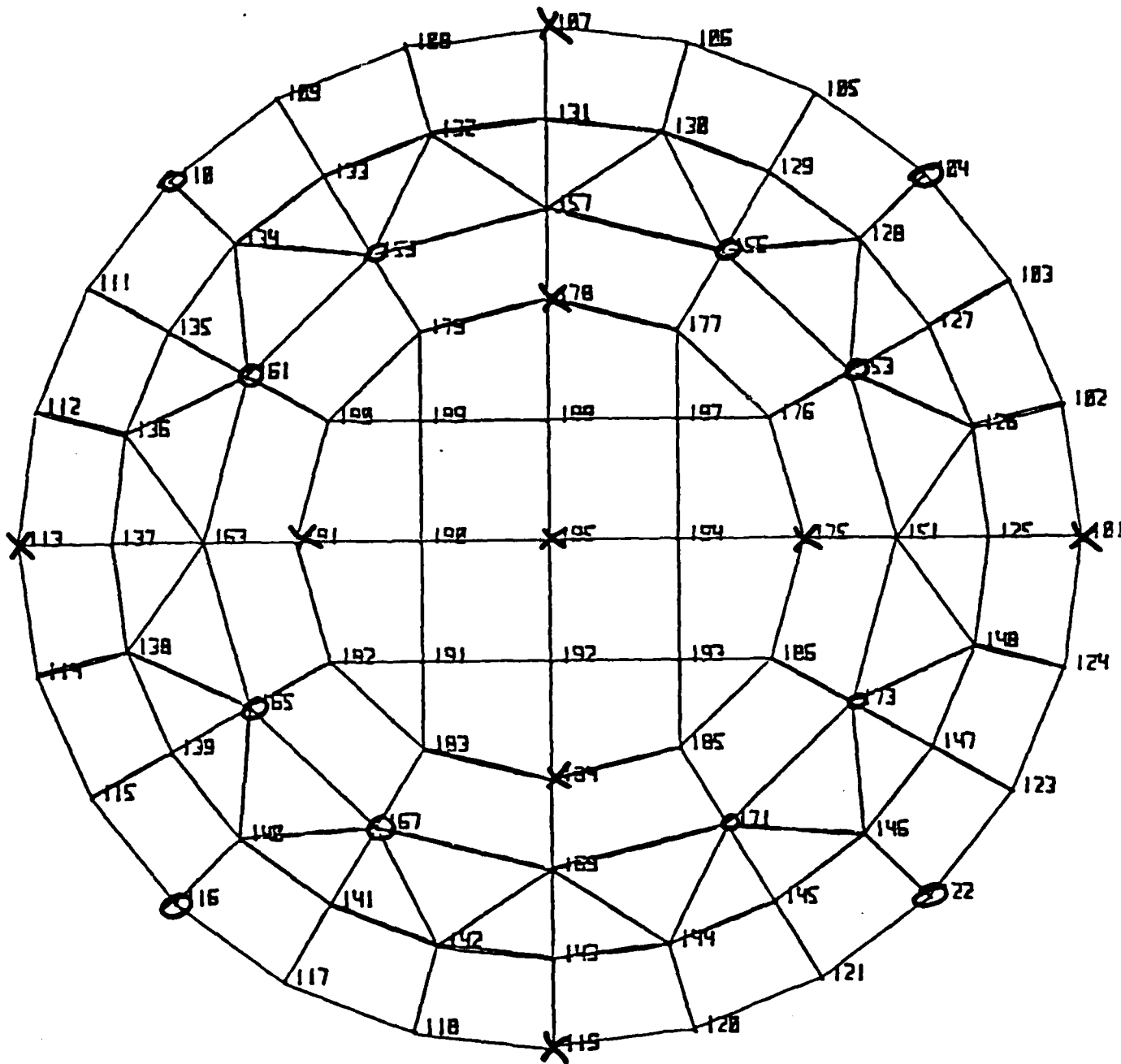

Figure 18. Plot of level 1 showing representative degrees of freedom placed in analysis set.

TABLE 9. NATURAL FREQUENCY RESPONSE OF UEJ DURING LAUNCH
(SETBACK)

Mode	Frequency (Hz)	Grid Point and Direction of Max. Deflection	W_{app_x}	W_{app_y}	W_{app_z}
1	510	7 y	1.46	0.20	0.01
2	593	9 y	6.63	0.10	0.0
3	850	9 y	0.07	2.64	0.02
4	974	9 z	0.0	3.00	.37
5	1021	7 z	0.0	0.57	1.22
6	1575	695 z	0.0	0.0	0.68
7	1892	195 z	0.0	0.0	0.51
8	1938	407 x	0.0	0.52	0.0
9	2318	543 z	0.0	0.0	0.0
10	2405	437 z	0.0	0.0	0.0
		Total	8.16	7.03	2.81

Note: The total apparent weight (W_{app}) for all frequencies in each direction should equal the weight of the jammer model.

TABLE 10. NATURAL FREQUENCY RESPONSE OF THE UEJ DURING LANDING

Mode	Frequency (Hz)	Grid Point and Direction of Max. Deflection
1	1861	195 z
2	2470	195 z
3	2968	42 x
4	3097	295 y
5	3438	295 x

5. SUMMARY OF MODEL WITH DETAILED CUTOUTS

The model of the UEJ jammer presented in this report is adequate to give a global representation of the forces and stresses. However, in the sleeve of the jammer there are two small areas with significantly reduced wall thickness. One is where the vane attaches; the effective wall thickness is 0.12 inches. The other area is just below this. It is rectangular in shape (0.75 inches x 0.2 inches) and has a wall thickness of only 0.063 inches. Stress concentrations will occur in these areas.

A detailed model of the sleeve between levels 4 and 6 for a sector containing one vane to the start of another was developed, as shown in Figure 19. A static analysis was performed for the launch and landing conditions and the results for this analysis are shown in Tables 11 and 12. These tables should be compared with Tables 1 and 2 for the corresponding overall model. We see that the stress in the sleeve for the launch condition rises dramatically, from 17,200 psi to 29,900 psi for a 1000 g load.

There is also a possibility that part of the sleeve will be cut entirely away near the vane attachment. This was modeled by entirely removing the plate elements for this cutout region, as shown in Figure 19, leaving alone the rest of the detailed model. The results of the analysis for the launch condition (the worst case) are shown in Table 13. The stresses are comparable with those shown in Table 11.

604	941	942	601	944	945	602	947	946	603
950	951	952	953	954	955	956	957	958	959
960	961	962	963	964	965	966	967	968	969
504	971	972	501	974	975	502	977	978	503
920	921	922	923	924	925	926	927	928	929
910	911	912	913	914	915	916	917	918	919

404 901 902 401 904 905 402 907 906 403

Section "A"

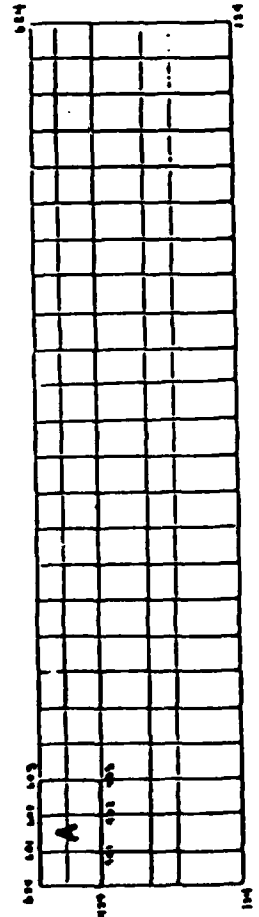

Note: In detailed area each quadrilateral was divided into a 3 x 3 array of quadrilateral elements.

Figure 19. Sleeve showing area modeled in detail.

TABLE 11. SUBCASE 1: SETBACK - PEAK STRESSES IN UNATTENDED EXPENDABLE JAMMER FOR 1000 g LOAD IN AXIAL DIRECTION

Computer Run: YMJTYDET (April 10, 1980)

Constraint Conditions: SPC'd at Level 6 (Cover Plate) in x, y, and z directions. Note: 40 lbs of mass was added to perimeter of base plate to model compressive force of the five remaining jammers.

Body, Sleeve, and Cover Model: Detailed Model of Sleeve Around Recesses for Vane Attachments

Peak Stresses

UEJ Part	Element Type	Element ID Range	Element ID with Peak Stress	Peak Stress (psi)
Base Plate	CQUAD4	101-162	126	9,830
Power Pack	"	201-262	259	435
RF PCB	"	301-362	313	904
Cover	"	601-662	623	-12,500
Sleeve	"	701-824	803	22,000
Detailed Sleeve Area	"	901-959	919	29,900
Base Plate	CTRIA2	101-140	101	10,200
Power Pack	CTRIA1	201-240	240	122
RF PCB	CTRIA1	301-340	331	881
Cover	CTRIA2	601-640	638	6,890
Antenna	CBAR	1-16	13	-5,170
Lip on Lower Sleeve	"	901-924	901	2,610
Body	"	927-963	962	9,700
Power Pack	CROD	1125-1195	1145	57
Foam Level 2-3	"	1225-1295	1295	-31
Foam Level 3-4	"	1325-1381	1331	20
Foam Level 4-5	"	1425-1481	1443	31
Fiberglass Insert	"	1525-1581	1555	73

TABLE 12. SUBCASE 2: GROUND IMPACT - PEAK STRESSES IN UN-ATTENDED EXPENDABLE JAMMER FOR 1000 g LOAD IN AXIAL DIRECTION

Computer Run: YMJTYDEB (April 10, 1980)

Constraint Conditions: SPC'd at Level 1 (Bottom Plate) in x, y, and z directions.

Body, Sleeve, and Cover Model: one set of grid points common to all. Detailed model of sleeve around recesses for vane attachments.

Peak Stresses

UEJ Part	Element Type	Element ID Range	Element ID with Peak Stress	Peak Stress (psi)
Base Plate	CQUAD4	101-162	126	10,200
Power Pack	"	201-262	259	355
RF PCB	"	301-362	361	-602
Cover	"	601-662	631	-12,000
Sleeve	"	701-824	823	6,850
Detailed Sleeve Area	"	901-959	954	9,760
Base Plate	CTRIA2	101-140	104	-11,000
Power Pack	CTRIA1	201-240	237	35
RF PCB	CTRIA1	301-340	331	-437
Cover	CTRIA2	601-640	638	7,300
Antenna	CBAR	1-16	13	-2,960
Lip on Lower Sleeve	"	901-924	917	889
Body	"	927-963	953	4,810
Power Pack	CROD	1125-1195	1145	102
Foam Level 2-3	"	1225-1295	1245	25
Foam Level 3-4	"	1325-1381	1343	101
Foam Level 4-5	"	1425-1481	1471	21
Fiberglass Insert	"	1525-1581	1555	64

TABLE 13. SUBCASE 1. SETBACK - PEAK STRESSES IN UNATTENDED EXPENDABLE JAMMER FOR 1000 g LOAD IN AXIAL DIRECTION

Computer Run: YMJTY DTP (April 22, 1980)

Constraint Conditions: SPC'd x, y, and z at cover plate (601-624).

Body, Sleeve, and Cover Model: one set of grid points common to all. Detailed model of sleeve around recesses for vane attachments, including cutout.

Peak Stresses

UEJ Part	Element Type	Element ID Range	Element ID with Peak Stress	Peak Stress (psi)
Base Plate	CQUAD4	101-162	126	9820
Power Pack	"	201-262	259	434
RF PCB	"	301-362	313	898
Cover	"	601-662	614	12,300
Sleeve	"	701-824	823	-17,700
Detailed Sleeve Area	"	901-959	919	-29,000
Base Plate	CTRIA2	101-140	103	10,080
Power Pack	CTRIA1	201-240	238	119
RF PCB	CTRIA1	301-340	331	890
Cover	CTRIA2	601-640	638	6,840
Antenna	CBAR	1-16	13	5,190
Lip on Lower Sleeve	"	901-924	906	2,290
Body	"	927-963	927	2,090
Power Pack	CROD	1125-1195	1145	56
Foam Level 2-3	"	1225-1295	1295	-31
Foam Level 3-4	"	1325-1381	1331	-20
Foam Level 4-5	"	1425-1481	1431	-29
Fiberglass Insert	"	1525-1581	1555	-73

6. CONCLUSIONS

A NASTRAN finite element model of the UEJ was developed. Static and modal analyses were performed with this model for both launch and landing conditions. The major conclusions are summarized below.

(1) There should be a lip on the sleeve which extends down below the base plate. Currently the bottom of the sleeve and the base plate are flush. This lip would insure that stress transfer between the jammer units would occur through the sleeve and not from the cover of one unit to the base plate of a second unit.

(2) Some material may be removed from the center of the annular region in the base plate by undercutting. The strength of this plate is determined by the thickness of the annular region and no particular gain is realized by making the center region thicker.

(3) Based on the geometry and material, compressive failure of the material will occur before the jammer unit buckles.

(4) The fundamental frequency of the jammer unit in the axial direction is sufficiently high that a detailed transient analysis for the launch condition is not justified.

(5) Peak stresses in the jammer unit will occur during launch. Stress concentrations occur in the sleeve near the recesses and where the vanes attach.

(6) In the four places where the body and sleeve are pinned together, as well as the four places where the cover and body are pinned, very high stresses can occur if these parts are not seated properly. The screw holes should be counterbored to insure that the pieces are flush.

(7) The peak stresses in the sleeve near the recessed areas for the vane attachments are 29,900 psi for a 1000 g axial load compared with 17,200 psi when the recessed areas are not present.

APPENDIX A. -- NASTRAN SECTION PROPERTIES

This section shows cross-sectional views for all the CBAR elements used in the UEJ model. The area, principal moments, torsion constant, shear coefficients and stress recovery coefficients are indicated for each bar element, as is the orientation of the v vector in the model.

Section Properties for Antenna Saddle: PBAR 1.

$$\text{Area} = 0.5074 \text{ in.}^2$$

$$\text{Moment of Inertia } I_1 = 0.00668 \text{ in.}^4$$

$$\text{Moment of Inertia } I_2 = 0.11 \text{ in.}^4$$

$$\text{Torsion Constant } J = 0.005758 \text{ in.}^4$$

Section Properties for Antenna Spool: PBAR 2.

$$\text{Area} = 0.111 \text{ in.}^2$$

$$\text{Moment of Inertia } I_1 = \text{Moment of Inertia } I_2 = 0.00694 \text{ in.}^4$$

$$\text{Torsion Constant } J = 0.01389 \text{ in.}^4$$

$$\text{Shear Coefficients: } K_1 = K_2 = 0.502$$

Stress Recovery Coefficients:

$$(C_1, C_2) = (0.0, -0.378)$$

$$(D_1, D_2) = (0.378, 0.0)$$

$$(E_1, E_2) = (0.0, 0.378)$$

$$(F_1, F_2) = (-0.378, 0.0)$$

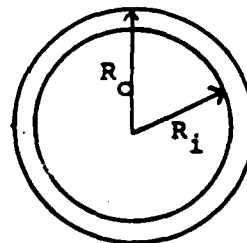

$$R_o = 0.378 \text{ in.}$$

$$R_i = 0.328 \text{ in.}$$

Section Properties for Saddle Support: PBAR 3.

Equivalent properties used.

$$\text{Area} = 0.1 \text{ in.}^2$$

$$\text{Moments of Inertia } I_1 = I_2 = 0.1 \text{ in.}^4$$

Section Properties for Antenna Post: PBAR 4.

$$\text{Area} = 0.442 \text{ in.}^2$$

$$\text{Moments of Inertia } I_1 = I_2 = 0.0155 \text{ in.}^4$$

$$\text{Torsion Constant } J = 0.031 \text{ in.}^4$$

$$\text{Shear Coefficients: } K_1 = K_2 = 0.75$$

Stress Recovery Coefficients:

$$(C_1, C_2) = (0.0, 0.375)$$

$$(D_1, D_2) = (0.375, 0.0)$$

$$(E_1, E_2) = (0.0, -0.375)$$

$$(F_1, F_2) = (-0.375, 0.0)$$

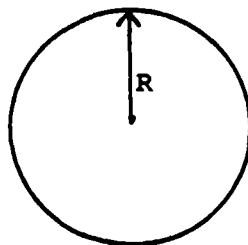

$$R = 0.375 \text{ in.}$$

Section Properties for Antenna Post: PBAR 5.

Area = 0.2454 in.²

Moments of Inertia I₁ = I₂ = 0.01246 in.⁴

Torsion Constant J = 0.0249 in.⁴

Shear Coefficients: K₁ = K₂ = 0.5132

Stress Recovery Coefficients:

(C₁,C₂) = (0.0,-0.375)

(D₁,D₂) = (0.375,0.0)

(E₁,E₂) = (0.0,0.375)

(F₁,F₂) = (-0.376,0.0)

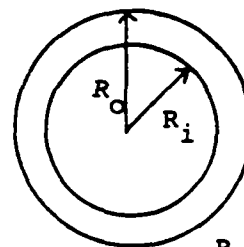

R_i = 0.25 in.

R_o = 0.375 in.

Section Properties for Antenna Post Support: PBAR 6.

Area = 0.25 in.²

Moment of Inertia I₁ = 0.0013 in.⁴

Moment of Inertia I₂ = 0.0208 in.⁴

Torsion Constant J = 0.00437 in.⁴

Shear Coefficients: K₁ = K₂ = 0.67

Stress Recovery Coefficients:

(C₁,C₂) = (0.125,-0.5)

(D₁,D₂) = (-0.125,-0.5)

(E₁,E₂) = (0.125,0.5)

(F₁,F₂) = (-0.125,0.5)

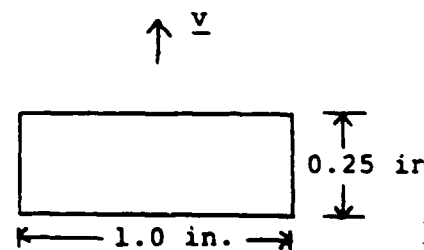

Section Properties for Antenna: PBAR 7.

Area = 0.4853 in.²

Moments of Inertia I₁ = I₂ = 0.09214 in.⁴

Torsion Constant J = 0.1843 in.⁴

Shear Coefficients: K₁ = K₂ = 0.5035

Stress Recovery Coefficients:

(C₁,C₂) = (0.0,-0.676)

(D₁,D₂) = (0.676,0.0)

(E₁,E₂) = (0.0,0.676)

(F₁,F₂) = (-0.676,0.0)

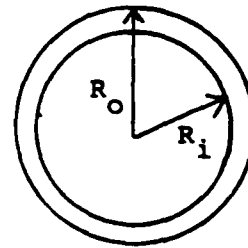

R_o = 0.676 in.

R_i = 0.55 in.

Section Properties for Lip Around Bottom of Sleeve: PBAR 901.

Area = 0.0735 in.²

Moment of Inertia I₁ = 0.0001876 in.⁴

Moment of Inertia I₂ = 0.00108 in.⁴

Torsion Constant J = 0.0005472 in.⁴

Shear Coefficients: K₁ = K₂ = 0.67

Stress Recovery Coefficients:

(C₁,C₂) = (0.0875,-0.21)

(D₁,D₂) = (-0.0875,-0.21)

(E₁,E₂) = (0.0872,0.21)

(F₁,F₂) = (-0.0875,0.21)

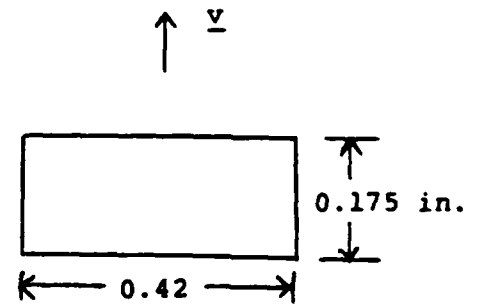

Section Properties for Body: PBAR 925.

Area = 0.0412 in.²

Moment of Inertia I1 = 0.0003323 in.⁴

Moment of Inertia I2 = 0.0000994 in.⁴

Torsion Constant J = 0.000112 in.⁴

Shear Coefficient K1 = 0.505

Shear Coefficient K2 = 0.5302

Stress Recovery Coefficients:

(C1,C2) = (0.179,0.0846)

(D1,D2) = (-0.133,0.0846)

(E1,E2) = (-0.133,-0.095)

(F1,F2) = (0.0,0.0)

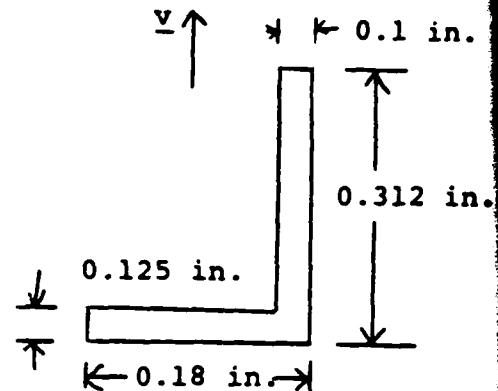

Section Properties for Body: PBAR 926.

Area = 0.1196 in.²

Moment of Inertia I1 = 0.00087 in.⁴

Moment of Inertia I2 = 0.00249 in.⁴

Torsion Constant J = 0.000869 in.⁴

Shear Coefficient K1 = 0.67

Shear Coefficient K2 = 0.328

Stress Recovery Coefficients:

(C1,C2) = (0.135,-0.281)

(D1,D2) = (0.135,0.187)

(E1,E2) = (-0.177,-0.00084)

(F1,F2) = (-0.177,0.257)

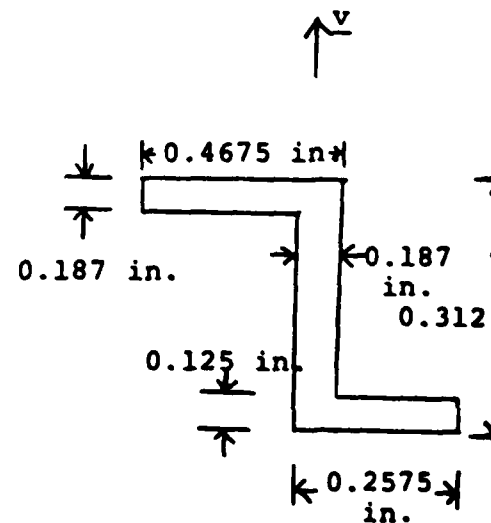

Plate Properties

PQUAD4 11

Base plate

$t = 0.25 \text{ in.}$

PQUAD4 12

Base plate

$t = 0.075 \text{ in.}$

PQUAD4 21

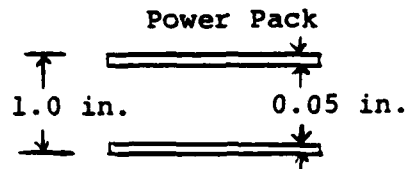

$t = 0.1 \text{ in.}$

$I = 2(0.05)(0.5)^2 = 0.025 \text{ in.}^3$

PQUAD4 31

RF PCB

$t = 0.062 \text{ in.}$

PQUAD4 32

RF PCB

$t = 0.187 \text{ in.}$

PQUAD4 33

RF PCB

$t = 0.312 \text{ in.}$

PQUAD4 61

Cover

$t = 0.187 \text{ in.}$

PQUAD4 701

Sleeve

$t = 0.225 \text{ in.}$

PQUAD4 702

Sleeve

$t = 0.307 \text{ in.}$

APPENDIX B. -- UEJ MATERIAL PROPERTIES

The following table summarizes the mechanical properties of the materials in the UEJ that were used in the NASTRAN model.

TABLE B-1. MATERIAL SUMMARY FOR UEJ

Material	Young's Modulus (psi)	Poisson's Ratio	Density (lb/in ³)	F _{t_y} (psi)	F _{c_y} (psi)	F _{s_y} (psi)
Steel 4130	29.0x10 ⁶	0.32	0.283	120x10 ³	120x10 ³	80x10 ³
G10	1.4x10 ⁶	0.3	0.066	40x10 ³	60x10 ³	19x10 ³
Isofoam	1.0x10 ⁴	0.3	0.010	--	1.6x10 ³	--
Al 2024	10.4x10 ⁶	0.33	0.1	62x10 ³	38x10 ³	37x10 ³
Epon 815	4.0x10 ⁵	0.34	0.063	3.1x10 ³	3.1x10 ³	--
Polycarbafil	1.7x10 ⁶	0.3	--	18x10 ³	18.5x10 ³	--
Brass	13.0x10 ⁶	0.33	0.303	25x10 ³	25x10 ³	15x10 ³

DISTRIBUTION

DEFENSE DOCUMENTATION CENTER
ATTN: DDC-TCA (3 Copies)
CAMERON STATION, BLDG 5
ALEXANDRIA, VA 22314

HARRY DIAMOND LABORATORIES

ATTN: Director, Division 30000
ATTN: Chief, Laboratory 34000
ATTN: Chief, Branch 34200
ATTN: Chief, Branch 34300
ATTN: Chief, Branch 34400
ATTN: Chief, Branch 34500
ATTN: Chief, Branch 34600
ATTN: Library (3 copies)
ATTN: Chairman, Editorial Committee
ATTN: Chief, Branch 81300
ATTN: Public Affairs Office
ATTN: Record Copy, Branch 81200
ATTN: J. Miller, 34300
ATTN: C. Whelan, 34300
ATTN: J. Miller/M. Probst/S. Boring, Branch 36200
ATTN: C. Anstine, Branch 15400
ATTN: S. Hum, Branch 34300 (5 copies)
ATTN: P. Hershall, Branch 00251