

AD-A085 244

ARMY ENGINEER WATERWAYS EXPERIMENT STATION VICKSBURG--ETC F/6 13/2
PUMPING STATION FOR TECHE-VERMILION BASINS, ATCHAFALAYA RIVER, --ETC(U)
MAR 80 P E SAUNDERS, B P FLETCHER

UNCLASSIFIED

ML

[of]
ADA
085244

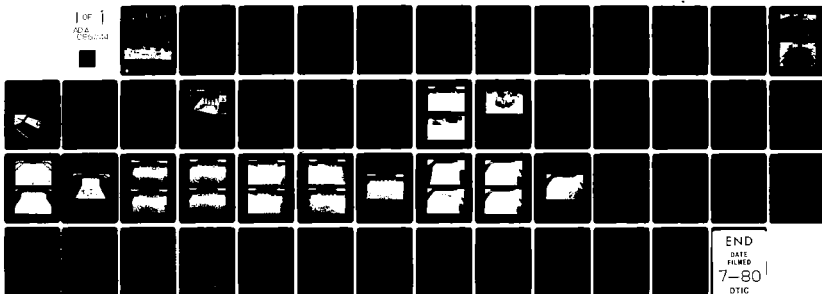

END
DATE
FILMED
7-80
DTIC

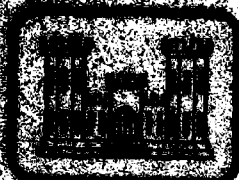

LEVEL

12



TECHNICAL REPORT HL-80-6

PUMPING STATION FOR TECHE-VERMILION BASINS, ATCHAFALAYA RIVER, LOUISIANA

Hydraulic Model Investigation

by

Peter E. Saunders, Bobby P. Fletcher

Hydraulics Laboratory

U. S. Army Engineer Waterways Experiment Station
P. O. Box 631, Vicksburg, Miss. 39180

March 1980
Final Report

Approved For Public Release; Distribution Unlimited

DTIC
ELECTE
JUN 6 1980
S D
A

ADA 085244



Prepared for U. S. Army Engineer District, New Orleans
New Orleans, Louisiana 70160

80 6 6 020

FILE COPY

**Destroy this report when no longer needed. Do not return
it to the originator.**

**The findings in this report are not to be construed as an official
Department of the Army position unless so designated
by other authorized documents.**

REPORT DOCUMENTATION PAGE		READ INSTRUCTIONS BEFORE COMPLETING FORM
1. REPORT NUMBER Technical Report HL-80-6	2. GOVT ACCESSION NO. ADA085244	3. RECIPIENT'S CATALOG NUMBER
4. TITLE (and Subtitle) PUMPING STATION FOR TECHE-VERMILION BASINS, ATCHAFALAYA RIVER, LOUISIANA; Hydraulic Model Investigation	5. TYPE OF REPORT & PERIOD COVERED Final Report, Sep 76 - Nov 77	6. PERFORMING ORG. REPORT NUMBER
7. AUTHOR(s) Peter E. Saunders Bobby P. Fletcher	8. CONTRACT OR GRANT NUMBER(s)	
9. PERFORMING ORGANIZATION NAME AND ADDRESS U. S. Army Engineer Waterways Experiment Station Hydraulics Laboratory P. O. Box 631, Vicksburg, Miss. 39180	10. PROGRAM ELEMENT, PROJECT, TASK AREA & WORK UNIT NUMBERS	
11. CONTROLLING OFFICE NAME AND ADDRESS U. S. Army Engineer District, New Orleans P. O. Box 60267 New Orleans, La. 70160	12. REPORT DATE March 1980	13. NUMBER OF PAGES 43
14. MONITORING AGENCY NAME & ADDRESS (if different from Controlling Office) 12 48	15. SECURITY CLASS. (of this report) Unclassified	15a. DECLASSIFICATION/DOWNGRADING SCHEDULE
16. DISTRIBUTION STATEMENT (of this Report) DISTRIBUTION STATEMENT A Approved for public release; Distribution Unlimited		
17. DISTRIBUTION STATEMENT (of the abstract entered in Block 20, if different from Report)		
18. SUPPLEMENTARY NOTES 14 WES/TR/HL-80-6		
19. KEY WORDS (Continue on reverse side if necessary and identify by block number) Channel flow Hydraulic models Pumping stations Teche-Vermilion Basins		
20. ABSTRACT (Continue on reverse side if necessary and identify by block number) The model study was conducted to evaluate the characteristics of flow in the inlet channel, original sump, energy dissipator (saxophone outlet), and outlet channel and to develop practical modifications required for improving the hydraulic performance of the structure. Hydraulic performance of the original design inlet channel and sump was satisfactory for all anticipated sump elevations with various (Continued)		

411389

LSW

Unclassified

SECURITY CLASSIFICATION OF THIS PAGE(When Data Entered)

20. ABSTRACT (Continued).

numbers and combinations of pumps operating. This was attributed to the relatively long and straight approach channel to the sump, the relatively long pumping bays, and the high submergence on the pumps at the minimum anticipated sump elevation. Tests conducted to investigate various size bell diameters indicated that for the range of bell diameters evaluated, there was no significant difference in the performance of flow entering the suction bell.

Hydraulic performance of the outlet structure and stability of the riprap in the outlet channel were improved by the addition of minor modifications developed during the model study.

Tests results indicated that the critical hydraulic conditions occurred with one pump operating and the basin initially dry. Flows from both the 45- and 90-degree discharge outlets passed over the original 20-ft-long stilling basin and impinged on the invert of the riprap-protected exit channel; therefore the stilling basin length was increased to 50 ft. The stilling basins vertical sides were replaced with 1V-on-3H paved slopes for economic reasons. The riprap thickness on the exit channel side slopes was increased from 18 to 24 in. to ensure rock stability for all anticipated flow conditions.

Unclassified

SECURITY CLASSIFICATION OF THIS PAGE(When Data Entered)

CONTENTS

	<u>Page</u>
PREFACE	1
CONVERSION FACTORS, U. S. CUSTOMARY TO METRIC (SI) UNITS OF MEASUREMENT	3
PART I: INTRODUCTION	5
The Prototype	5
Purpose of the Model Study	6
PART II: THE MODEL	7
Description	7
Interpretation of Model Results	7
PART III: TEST RESULTS	11
Method of Operation	11
Approach Channel, Sump, and Pump Intakes	11
Discharge Outlets, Stilling Basin, and Outlet Channel	13
PART IV: DISCUSSION	21
TABLE 1	
PHOTOS 1-4	
PLATES 1-11	

CONVERSION FACTORS, U. S. CUSTOMARY TO METRIC (SI)
UNITS OF MEASUREMENT

U. S. customary units of measurement used in this report can be converted to metric (SI) units as follows:

<u>Multiply</u>	<u>By</u>	<u>To Obtain</u>
cubic feet per second	0.02831685	cubic metres per second
feet	0.3048	metres
feet per second	0.3048	metres per second
inches	25.4	millimetres
miles (U. S. statute)	1.609344	kilometres

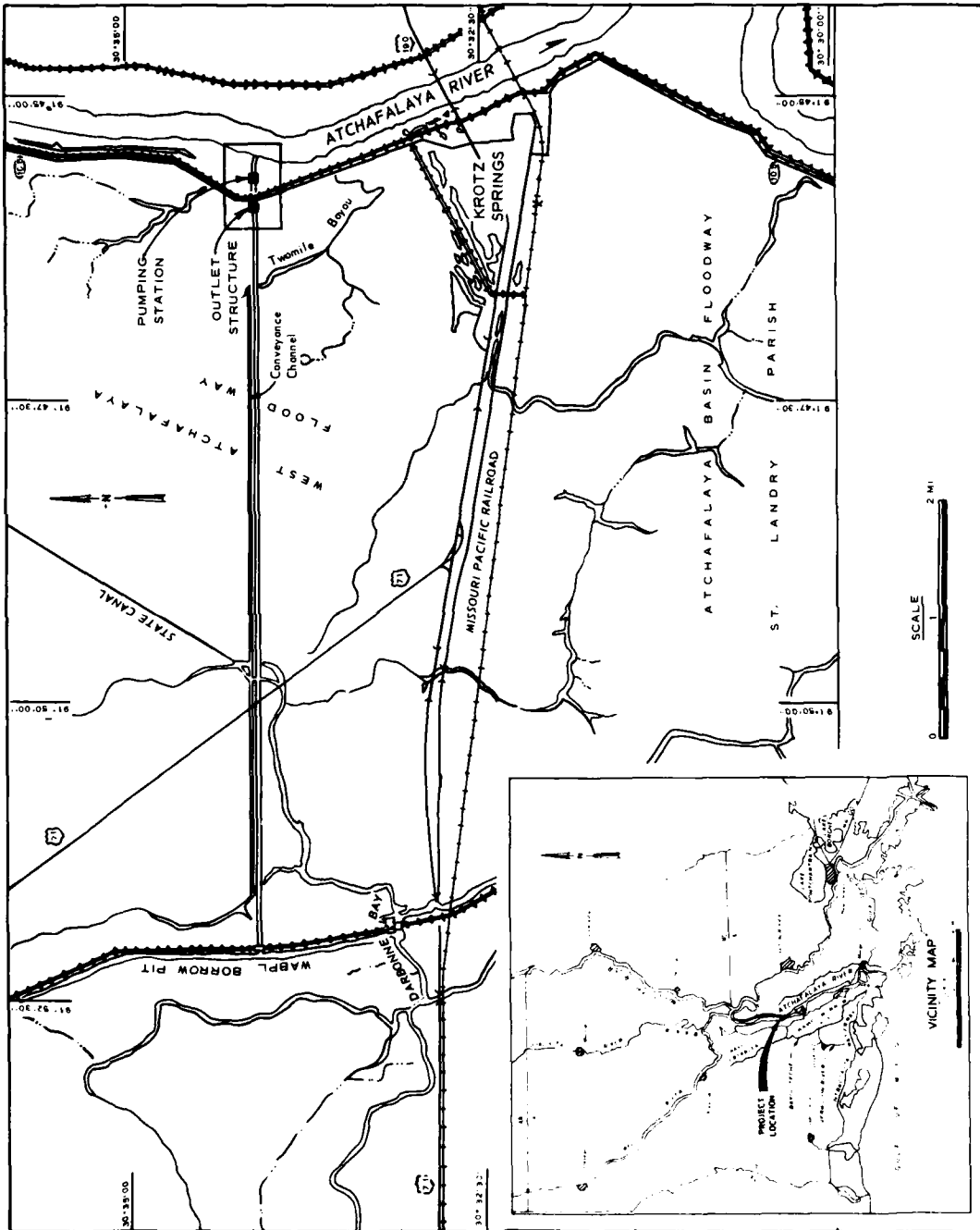

Figure 1. Location map

PUMPING STATION FOR TECHE-VERMILION BASINS

ATCHAFALAYA RIVER, LOUISIANA

Hydraulic Model Investigation

PART I: INTRODUCTION

The Prototype

1. The proposed pumping station for the Teche-Vermilion Basins will be located on the west bank of the Atchafalaya River in southern Louisiana, about 3 miles* north of Krotz Springs and 15 miles east of Opelousas, Louisiana (Figure 1). The pumping station will pump water from the Atchafalaya River into the drainage area for Bayou Teche and the Vermilion River and will provide supplementary fresh water to the surrounding area, for industrial, agricultural, and municipal use.

2. The plan and profile of the proposed design are shown in Plates 1-3. The five vertical, self-priming, wet pit, mixed-flow pumps will individually discharge over a protective levee into a common discharge basin. The pumps will be driven by horizontal electric motors through right angle gear reducers. During the minimum Atchafalaya River stage of 3.0 ft NGVD**, each pump shall have a capacity of 260 cfs at a total head of 27.3 ft. During average Atchafalaya River stage at 14.26 ft NGVD, each pump will have a capacity of 280 cfs at a total head of 18.0 ft. The pumps will be designed for siphonic operation and will be capable of priming the siphon at an approximate flow velocity of 7 fps at a total head of 48.12 during minimum river stage conditions. The pumps will discharge through individual 65-in. ID pipes over a protective levee with a crest at el 44.0 ft NGVD. The 45-degree "saxophone" type pipe outlets will discharge at an elevation of 21.0.

* A table of factors for converting U. S. customary units of measurement to metric (SI) units is presented on page 3.

** All elevations (el) cited herein are in feet referred to National Geodetic Vertical Datum (NGVD).

The saxophone outlets will maintain a constant pool of water in the pipes, thereby aiding in establishing siphonic flow and maintaining the recommended 24-ft negative pressure in the siphon crest during station design flow of 1,300 cfs. A combination vent and vacuum breaker valve at the siphon crest, controlled by pump start and stop, will aid in establishing and breaking the vacuum.

3. The discharge side of the pumping station will consist of five 65-in.-ID saxophone discharge pipes discharging into a concrete stilling basin. Riprap protection will be provided in the outlet channel.

Purpose of the Model Study

4. The model study was conducted to evaluate characteristics of flow in the inlet channel, sump, energy dissipator, and outlet channel and to develop practical modification required for improving the hydraulic performance of the structure. Tests were also conducted to determine the size and extent of rock protection required downstream from the energy dissipator.

PART II: THE MODEL

Description

5. The model (Figure 2) was constructed to an undistorted linear scale ratio of 1:16.25. The model of the approach area reproduced the sump, the pump intakes, about 700 ft of the approach channel, and about 230 ft either side of the approach channel center line. The model of the discharge side of the pumping station reproduced the saxophone discharge pipes, the concrete stilling basin, about 320 ft of the outlet channel, and about 100 ft either side of the outlet channel center line. The model limits are indicated in Plate 1. The approach and outlet channels were molded of cement mortar to sheet-metal templates. The stilling basin was constructed of marine plywood and the sump and pump intakes were constructed of plastic.

6. Flow into the five simulated pump columns to the stilling basin was provided by five centrifugal pumps; a separate pump returned the water to the approach channel. Flow from the pump intakes to the stilling basin was measured with turbine flow meters; return flow from the stilling basin to the pump intake was measured with an elbow meter. Water-surface elevations were measured with staff gages and velocities were measured with current meters. Pressure cells were placed beneath the pump intakes to determine instantaneous pressure fluctuations (Figure 3). Steel rails on both sides of the model provided a reference elevation and support for measuring devices. Pressure fluctuations and flow rates were monitored from the operation console located adjacent to the model (Figure 4).

Interpretation of Model Results

7. The accepted equations of hydraulic similitude, based upon Froudian criteria, were used to express the mathematical relations between the dimensions and hydraulic quantities of the model and prototype.

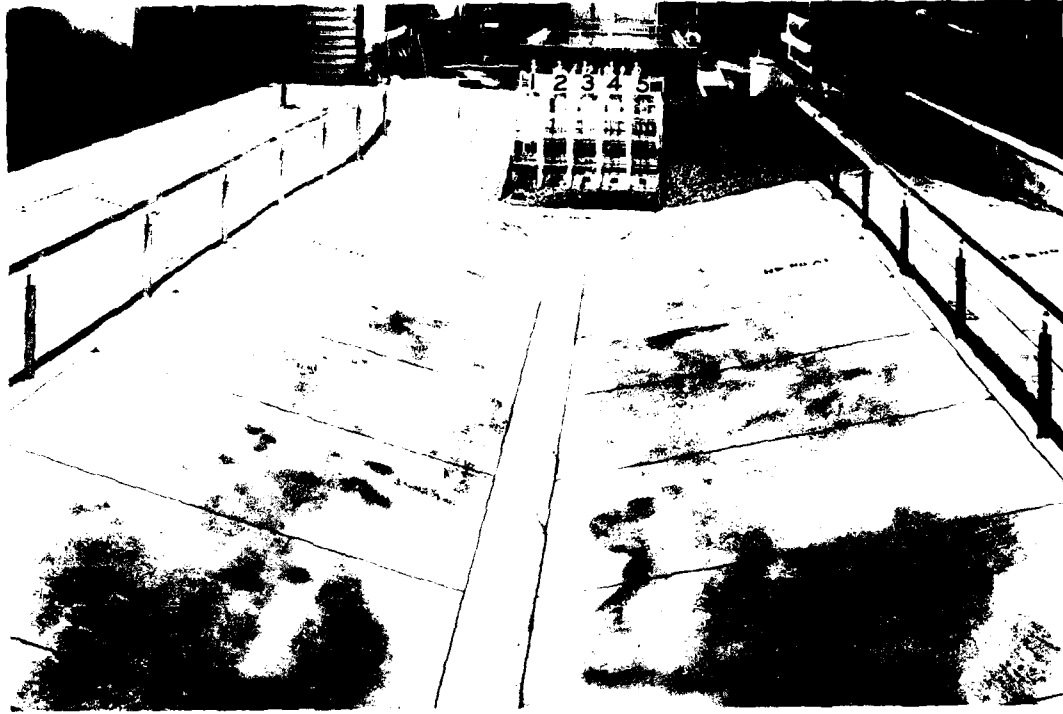

a. Approach to pumping station

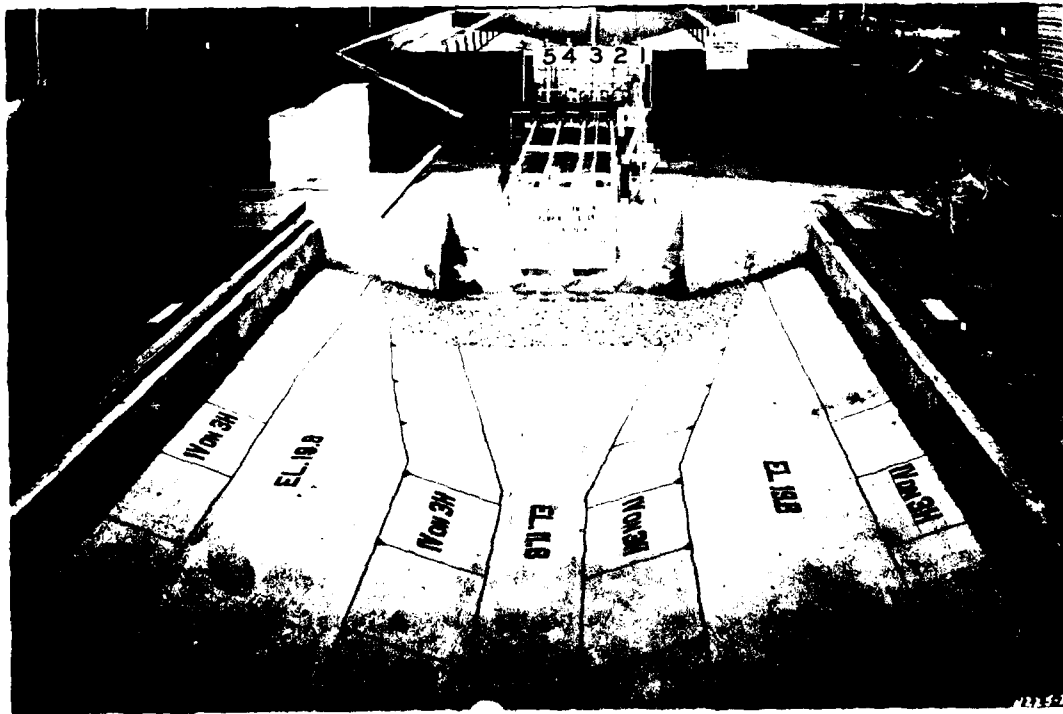

b. Exit from pumping station

Figure 2. The 1:16.25-scale model

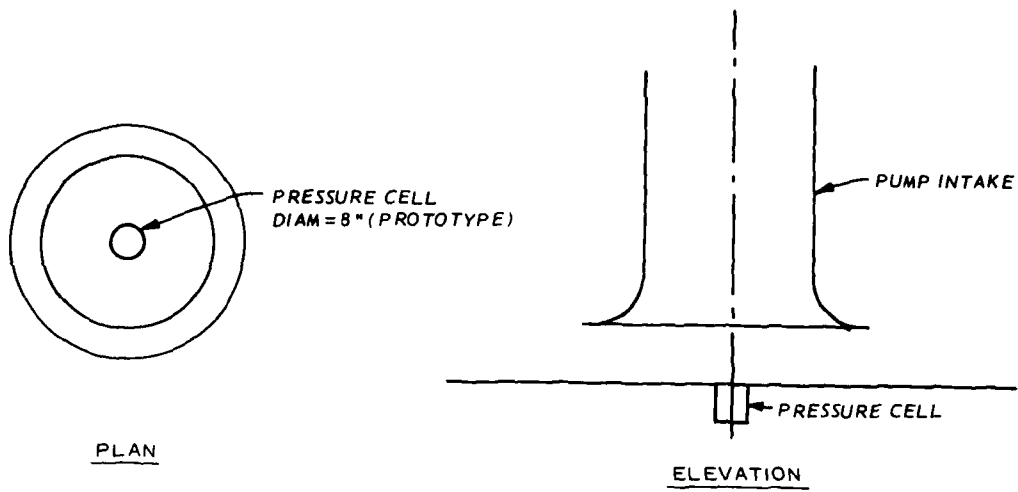

Figure 3. Pressure cell location

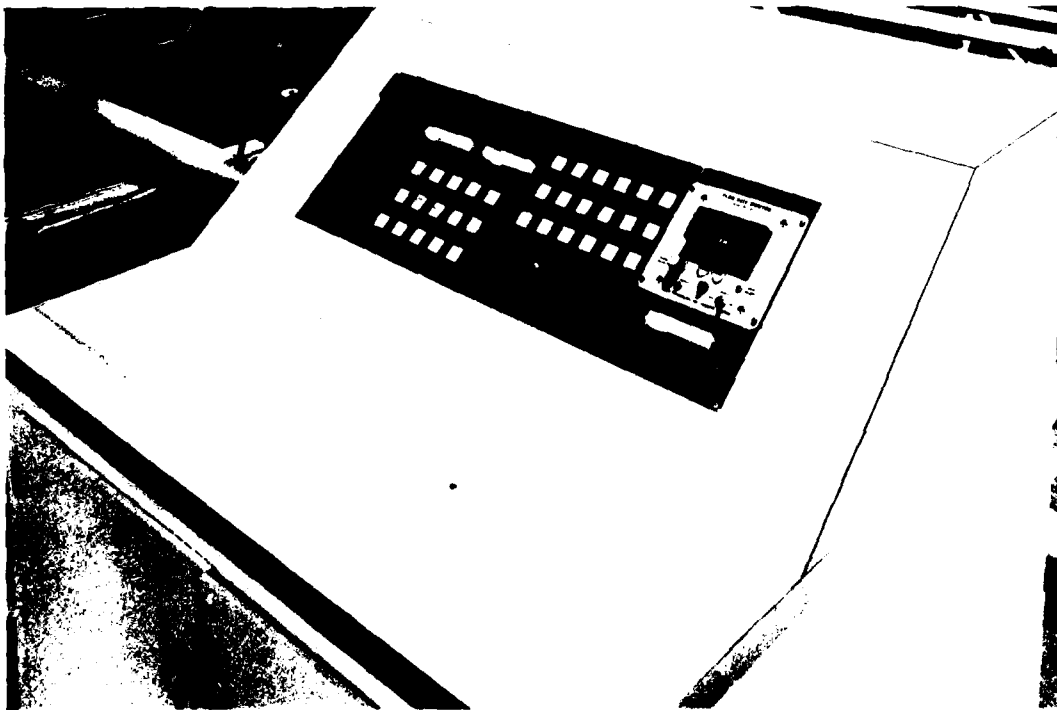

Figure 4. Model operation console

<u>Dimension</u>	<u>Ratio</u>	<u>Scale Relation</u>
Length	$L_r = L_r$	1:16.25
Area	$A_r = L_r^2$	1:264.06
Velocity	$V_r = L_r^{1/2}$	1:4.03
Discharge	$Q_r = L_r^{5/2}$	1:1065
Time	$T_r = L_r^{1/2}$	1:4.03
Manning's n	$n_r = L_r^{1/6}$	1:1.59
Pressure	$P_r = L_r$	1:16.25

8. Measurements of discharge, water-surface elevations, and pressure fluctuation can be transferred quantitatively from the model to the prototype by means of the scale relations above.

PART III: TEST RESULTS

Method of Operation

9. The proposed pumping station consists of five pumps separated by divider walls in the sump (Plates 2 and 3) with undivided outlets (Plate 4). The invert of the sump was at el -15.5 with the pump suction bell diameter to be determined by the model study. The pumps were manually operated with automatic monitoring of discharge from each pump. The minimum anticipated pool is el 3.0 with a maximum elevation of 40.0. Variation in water demand will require operation of various numbers of pumps and consideration of all pumping combinations at various water levels in the sump. Discharges and tailwaters from combinations of all five pumps operating were reproduced in accordance with the rating curve provided in Plate 5.

Approach Channel, Sump, and Pump Intakes

10. The approach channel has a bottom width of 20 ft and 1V-on-4H side slopes up from el -15.5 to a berm on both sides at el 17.0 (Plate 2). The relatively long and straight approach channel provides satisfactory flow distribution to the entrance of the pump sump. The wing walls (Figure 5) convey the flow from the approach channel to the sump and five pumps with a minimum of flow contractions and turbulence. Photo 1a shows flow patterns in the approach channel with the water level at el 40.0 and pumps 1, 2, 4, and 5 operating. Photos 1b and 1c show the same pump combination with the water level at el 14.0 and el 3.0, respectively. The surface flow patterns in Photo 1 indicate adverse flow conditions; however, flow conditions along the bottom of the approach channel, sump, and at the pump intakes were satisfactory. Flow to the pumps was fairly uniform regardless of the number or combination of pumps operating and no indication of surface vortex formation was evident. Velocities measured along the channel bottom at the sump entrance and downstream of the trashracks with pool elevations of 3.0,

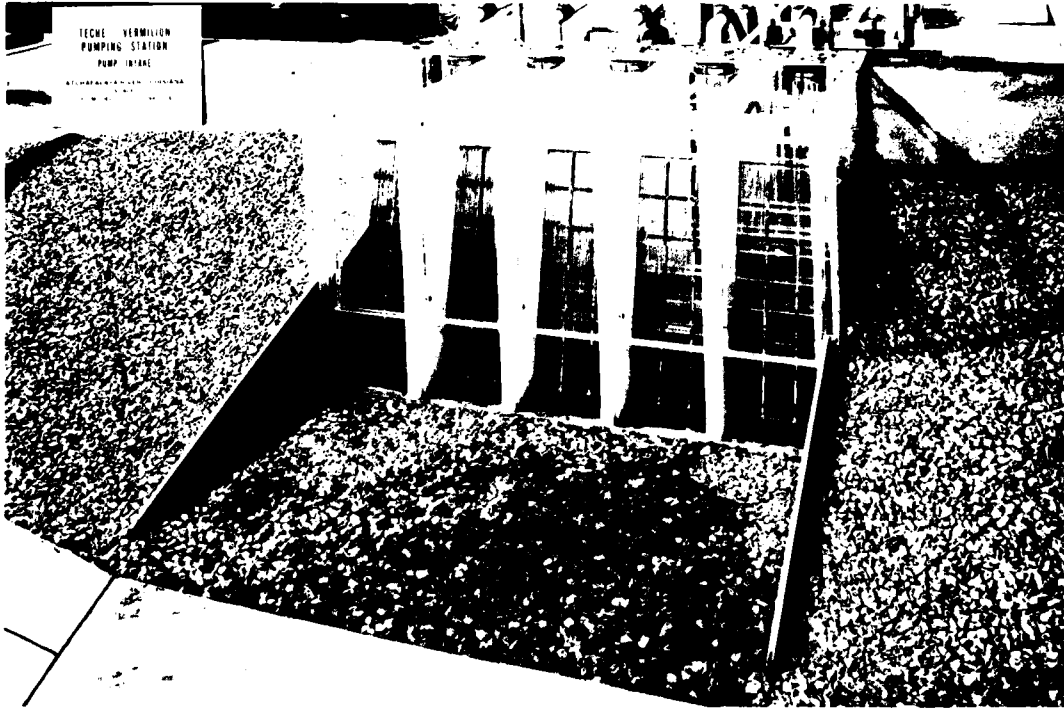

Figure 5. Approach to pump sump

14.0, and 36.0 and pumps 1, 2, 4, and 5 operating are presented in Plate 6.

11. Pressure cells (Figure 3) were mounted in the floor of each sump under the center of the pump suction bell. The pressure cells were installed to give a basis of qualitative comparison between various operating conditions and to determine the optimum bell diameter. Tests were conducted with simulated 70-, 84-, and 100-in.-diam suction bells over a representative range of submergence levels and combinations of pumps operating. Table 1 shows the maximum instantaneous pressure recorded under various hydraulic conditions indicating some improvement with the 84- and 100-in.-diam suction bells. Plate 7 indicates maximum pressure fluctuations relative to submergence for various flow conditions with 70-, 84-, and 100-in.-diam bells. The above pressure fluctuations (about ± 5 ft of water), measured for anticipated flow conditions, are not considered to be of sufficient magnitude to adversely influence

the performance of the pump. No significant surface vortex action was observed with the three bell diameters for the range of sump elevations anticipated. Test results indicated that varying the bell diameter did not significantly affect the hydraulic characteristics of flow entering the suction bell.

12. Tests were conducted with the 70-in.-diam bell to investigate sump elevations lower than those anticipated. Plate 8 illustrates the effects of pool elevations, lower than those anticipated, relative to pressure fluctuations for various combinations of pumps operating. Hydraulic performance was satisfactory for pool elevations as low as -8.0 (11 ft below minimum anticipated pool of el 3.0). Pool elevations below -8.0 produced air-entraining vortices.

13. The proposed (original) designs for the pumping station approach channel, sump, and pump intakes provide satisfactory hydraulic flow for all anticipated flow conditions. Tests also indicated that either the 70-, 84-, or 100-in.-diam suction bells could provide satisfactory flow to the pump. The satisfactory hydraulic performance observed at the inlet side of the pumping station was attributed to the relatively long and straight approach channel to the sump, the relatively long pumping bays, and the high submergence on the pumps.

Discharge Outlets, Stilling Basin, and Outlet Channel

Original design

14. The original design for the discharge outlets and stilling basin consisted of five 45-degree, 65-in.-ID saxophone discharge pipes discharging into a common stilling basin (Figure 6). The discharge pipes outlet was located at el 21.0. The stilling basin's 100-ft-wide and 20-ft-long apron was located at el 10.0, surmounted by vertical sidewalls and terminated by an end sill. A riprap-lined transition was provided from the 100-ft-wide stilling basin to the outlet channel. The outlet channel consisted of a 20-ft-wide invert at el 11.8 with 1V-on-3H side slopes to el 19.8.

15. Initially, tests were conducted for various tailwater

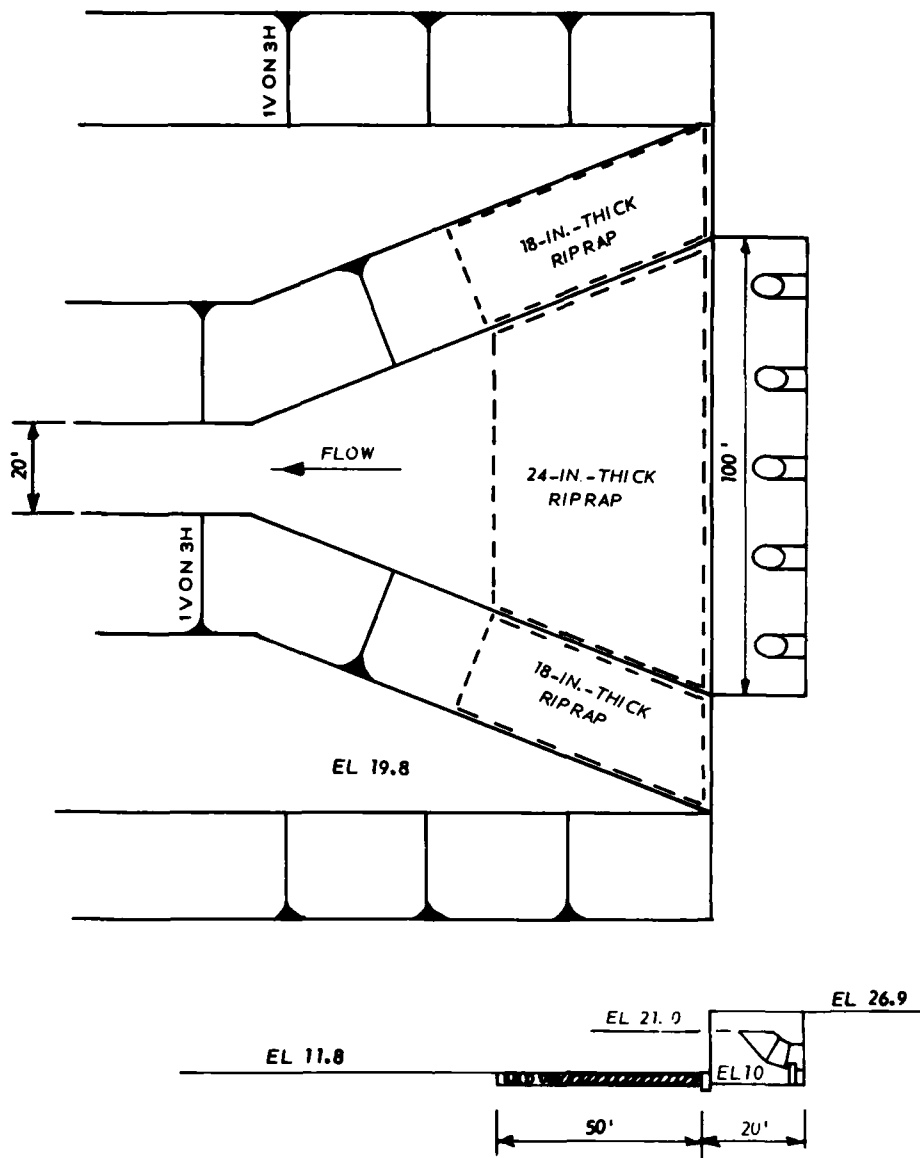

Figure 6. Original design stilling basin, 45-degree saxophone outlets

elevation and results indicated that stone displacement, for a given discharge, always occurred at the lower tailwater elevations. Subsequently, tests to evaluate stone displacement were conducted at the minimum tailwater corresponding to the number of pumps in operation. The critical condition was one pump operating with the basin initially dry (Figure 7). In the original design, the trajectory of flow from the discharge pipe extended about 20 ft beyond the stilling basin (Figure 7) and failed the 18-in.-thick layer of riprap on the side slope (Figure 8). Other flow conditions with the original design are shown in Photos 2a-2d. Velocity measurements taken 2 ft above the channel bottom are shown in Plate 9 for various flow conditions. It appeared that it would be advantageous to extend the length of the stilling basin and increase the size of the riprap protection or to change the angle of the discharge pipes.

Type 2 design

16. The discharge pipes in the type 2 design contained a 90-degree elbow; however, the trajectory of flow still extended about 4 ft beyond the stilling basin (Figure 9). Various flow conditions are illustrated in Photos 3a-3e. A 5-ft extension of the stilling basin (type 2-modified design) to a 25-ft total length (Figure 10) resulted in containment of the flow trajectory and satisfactory performance in the stilling basin and satisfactory velocity distribution in the downstream channel (Plate 10).

Type 3 design

17. Although the type 2 design was satisfactory from a hydraulic standpoint, the type 3 design was investigated for economic analyses conducted by the New Orleans District and indicated that sloping walls in lieu of vertical walls around the outlet would permit considerable savings. The type 3 design consisted of 45-degree saxophone outlets and a 50-ft-long stilling basin with 1V-on-3H slopes on each side and back of the stilling basin. Tests conducted with the original design indicated that a 50-ft-long stilling basin would contain the flow trajectory from the 45-degree outlets. The outlet channel and stilling basin side slopes were protected with an 18-in.-thick layer of stone. The end sill was sloped to more readily permit rock or debris to be washed out of the

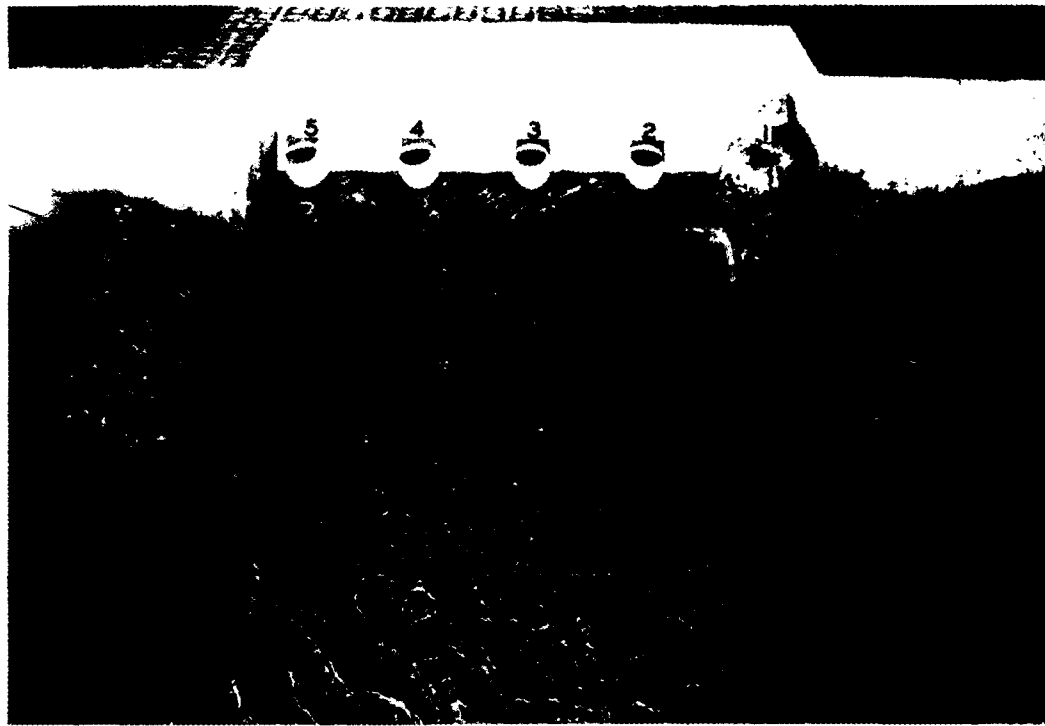

Figure 7. Original design discharge channel, pump 1 discharging (280 cfs) at minimum tailwater el 14.5 ft



Figure 8. Original design discharge channel; failure of 18-in.-thick layer of riprap on side slope resulting from pump 1 discharging 280 cfs, tailwater el 14.5 ft



Figure 9. Type 2 stilling basin, 90-degree elbow;
discharge 280 cfs, tailwater el 14.5 ft

basin. Photos 4a-4e show flow conditions resulting from one to five pumps discharging 280 cfs each at the respective lowest tailwater elevations anticipated. During operation of one pump with minimum tailwater (Photo 4a), riprap washed off the side slope and into the stilling basin. With five pumps operating and the respective minimum tailwater elevation, there was slight movement of the stones composing the 18-in.-thick riprap on the channel side slopes downstream of the stilling basin. The stones became more stable as the tailwater elevation was increased above the minimum anticipated.

Type 3-modified
(recommended) design

18. At a meeting between representatives from the U. S. Army Engineer District, New Orleans, the U. S. Army Engineer Division, Lower Mississippi Valley, and the U. S. Army Engineer Waterways Experiment Station, it was decided to adopt the type 3 design with a few minor

Blanket Thickness in.	Percent Lighter by Weight	Recommended Limits of Stone by Weight, lb
18	100	292-117
	50	86- 58
	15	43- 18
24	100	691-276
	50	205-138
	15	102- 43

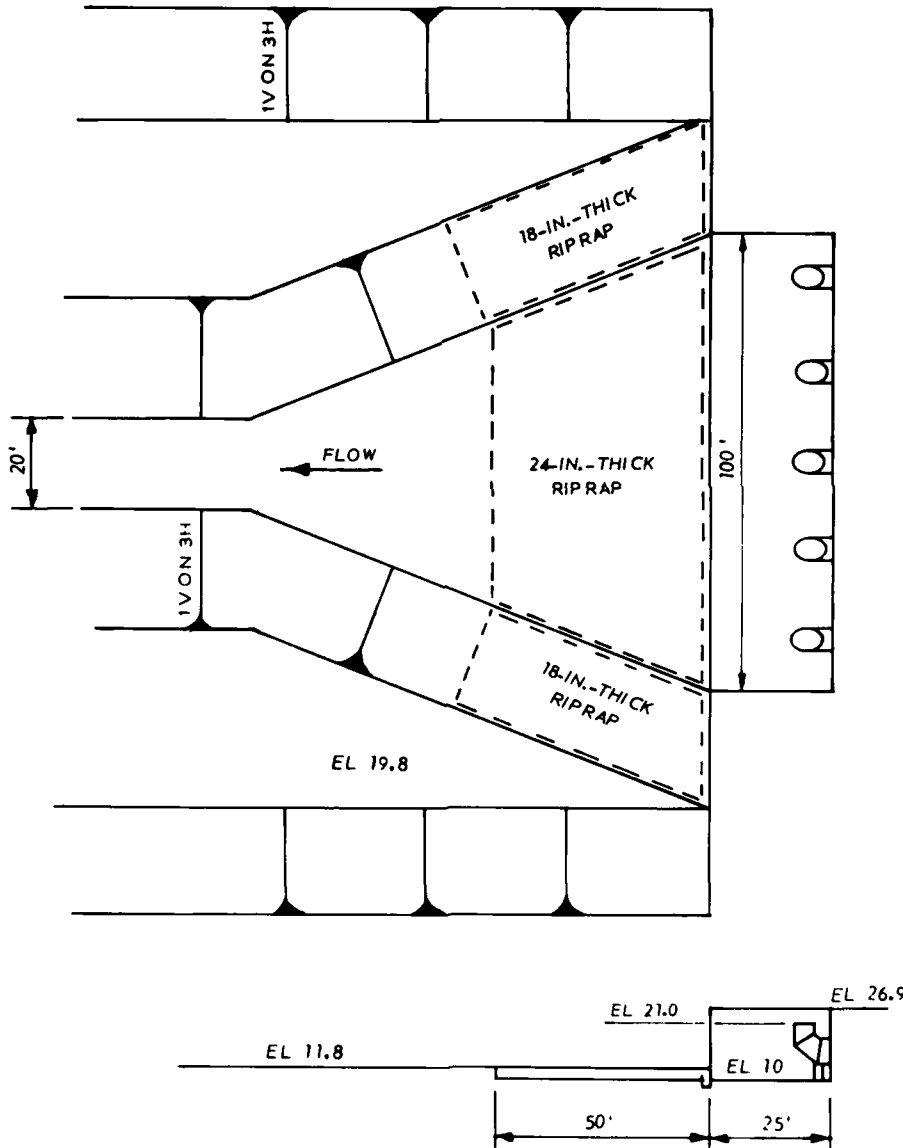

Figure 10. Type 2-modified stilling basin, 90-degree saxophone outlets

modifications. The possibility of riprap failure was reduced by extending concrete paving up the side slopes around the stilling basin and increasing the riprap thickness and stone weight on the downstream channel side slopes from 18 to 24 in. and 292 to 691 lb W_{max} , respectively (Figure 11 and Plate 4). The paving on the stilling basin side slopes was terminated at the upper edge by a ledge to prevent stone from rolling onto the slab. Model tests of the type 3-modified design indicated that paving around the stilling basin should extend to el 14.5 on the rear slope and to el 17.0 on the side slopes and that the 24-in.-thick riprap ($W_{max} = 691$ lb) on the channel side slopes was stable for all anticipated flow conditions. Bottom velocities and current directions for various flow conditions are indicated in Plate 11. Flow characteristics in the recommended design were identical with those observed for various pumps operating in the type 3 design (Photo 4). The recommended design (Figure 11) was considered to provide satisfactory hydraulic performance and adequate stone protection for the range of anticipated flow conditions. Although the recommended design is not as hydraulically effective as the type 2 design because of the reverse currents in the stilling basin (Plate 11), it was recommended because of the cost savings realized from the sloping walls around the stilling basin in lieu of the vertical walls.

Blanket Thickness in.	Percent Lighter by Weight	Recommended Limits of Stone by Weight, lb
18	100	292-117
	50	86- 58
	15	43- 18
24	100	691-276
	50	205-138
	15	102- 43

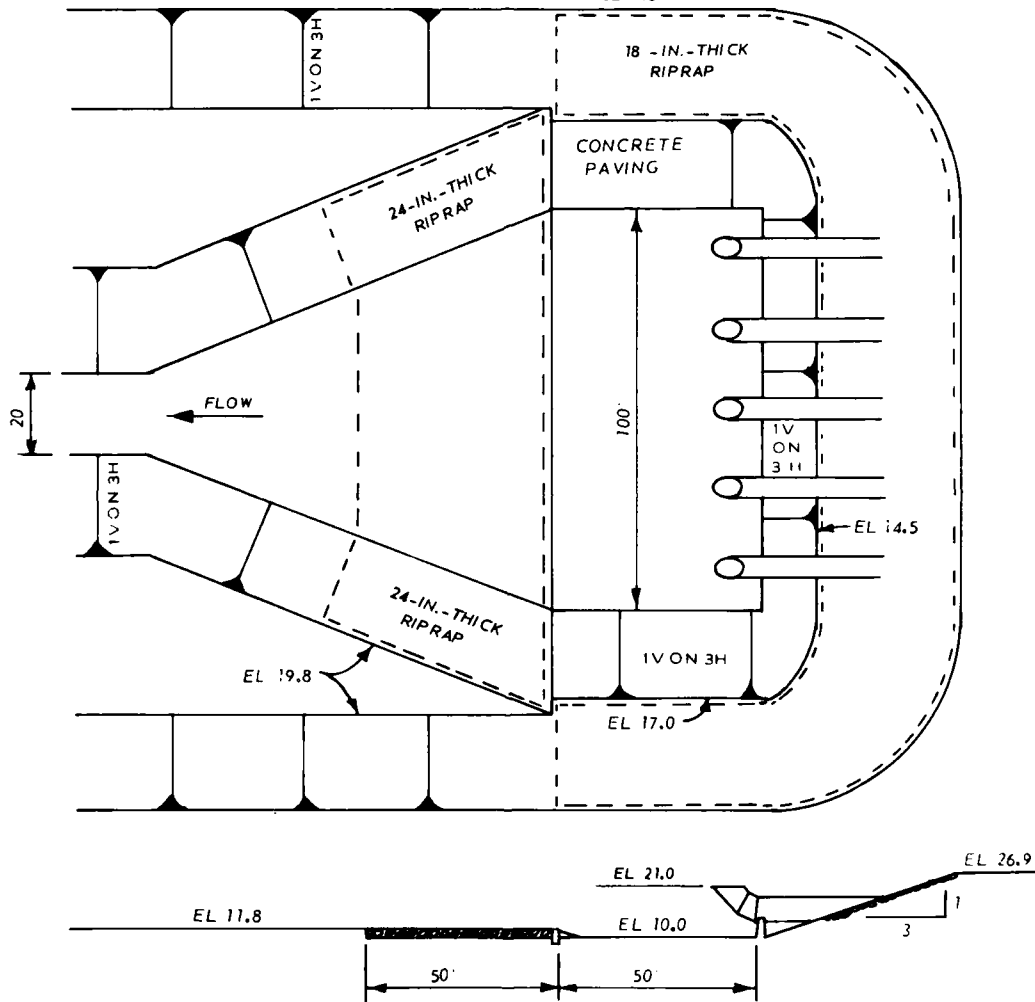

Figure 11. Type 3-modified (recommended) design stilling basin, 45-degree saxophone outlets

PART IV: DISCUSSION

19. Hydraulic performance of the original design inlet channel and sump was satisfactory for all anticipated sump elevations with various numbers and combinations of pumps operating. This was attributed to the relatively long and straight approach channel to the sump, the relatively long pumping bays, and the high submergence on the pumps at the minimum anticipated sump elevation. Tests conducted to investigate various size bell diameters indicated that for the range of bell diameters evaluated, there was no significant difference in the performance of flow entering the suction bell.

20. Hydraulic performance of the outlet structure and stability of the riprap in the outlet channel were improved by the addition of minor modifications developed during the model study.

21. Tests results indicated that the critical hydraulic conditions occurred with one pump operating and the basin initially dry. Flow exiting from the 45-degree saxophone discharge outlet passed over the 20-ft-long stilling basin apron and impinged on the invert of the riprap-protected exit channel, resulting in displacement of the stone. Similar results were observed with a 90-degree saxophone discharge outlet.

22. The jet was contained in the basin and satisfactory stilling basin performance was obtained with the 45-degree outlets by lengthening the stilling basin from 20 to 50 ft.

23. In the interest of economy, it was desirable to investigate the hydraulic feasibility of replacing the stilling basins vertical side-walls and rear walls with sloping (IV on 3H) walls. Tests results indicated that hydraulic performance with the slopes was satisfactory; however, tests also indicated the necessity for paving the slopes to reduce the possibility of rock sliding into the stilling basin. Should stones occasionally enter the basin, the end sill was sloped to facilitate their removal by hydraulic action in the stilling basin. Model tests also revealed that the riprap thickness and size on the exit channel side slopes should be increased from 18 to 24 in. (W_{max} from 292 to 691 lb) to ensure rock stability for all anticipated flow conditions.

Table 1
Maximum Pressure Fluctuations for Various Bell Diameters,
Pool Elevations, and Combinations of Pumps Operating
Discharge per Pump, 280 cfs

Bell Diameter in.	Pool Elevation ft NGVD	Maximum Pressure Fluctuation ft
70 ↓	3.0	3
	6.0	1.6
	16.0	1.4
	21.0	2.0
	26.0	4.0
	36.0	2.4
84 ↓	3.0	0.8
	14.0	1.1
	36.0	0.6
100 ↓	3.0	1.9
	14.0	0.3
	36.0	0.6

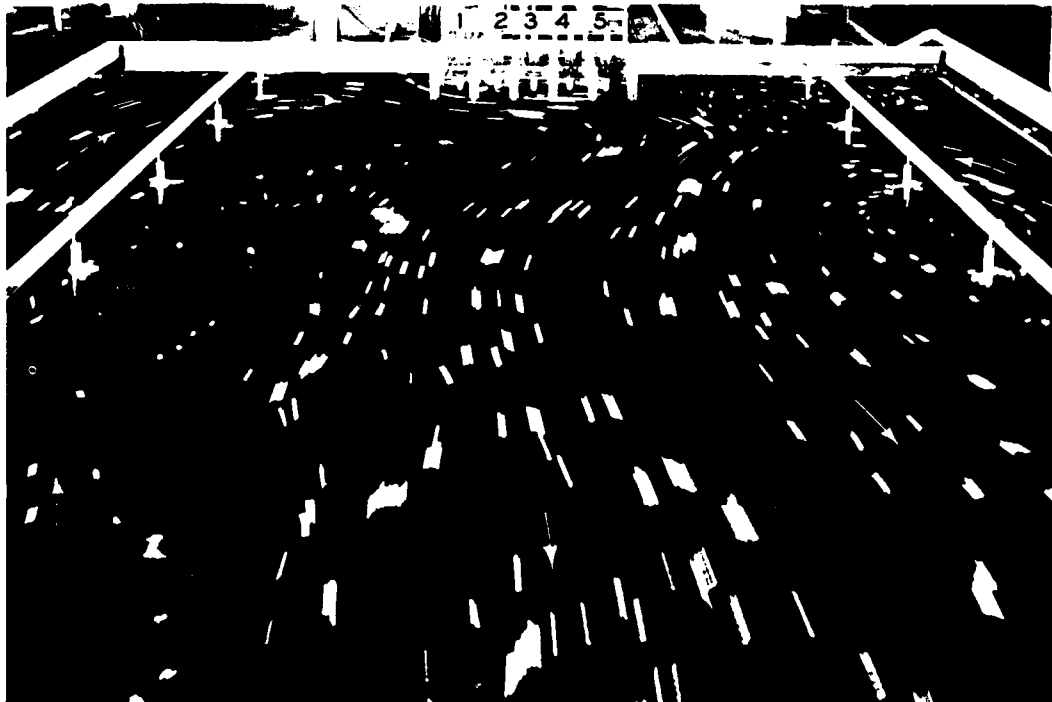

a. Pool el 40.0

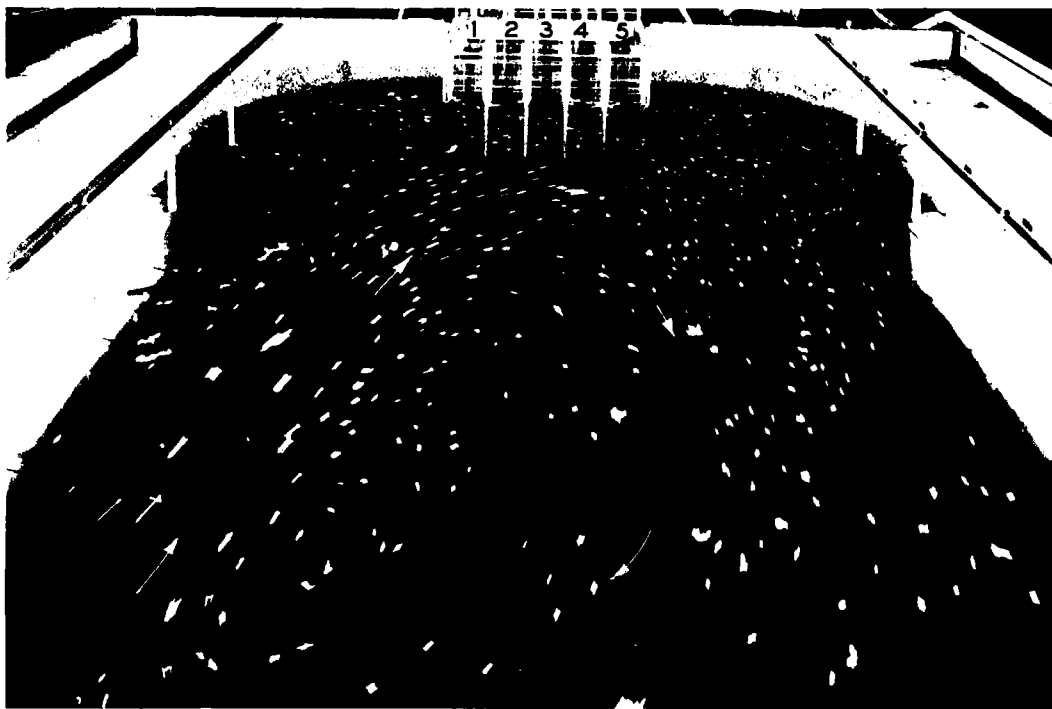

b. Pool el 14.0

Photo 1. Surface flow patterns, pumps 1, 2, 4, and 5 operating; discharge 280 cfs per pump (sheet 1 of 2)

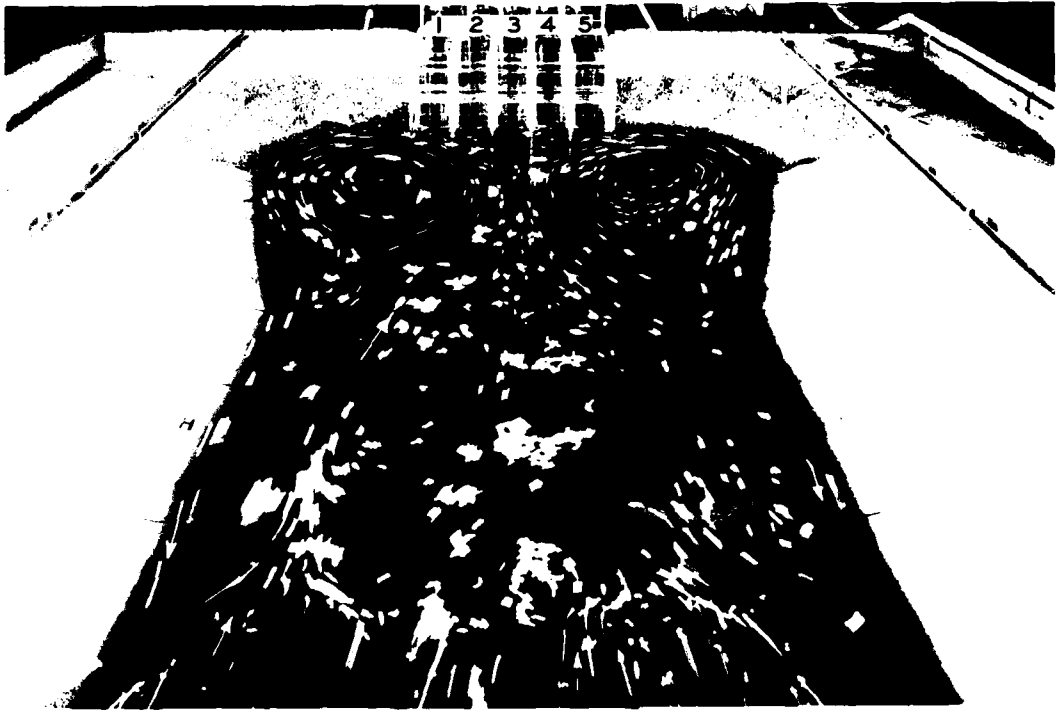

c. Pool el 3.0

Photo 1 (sheet 2 of 2)

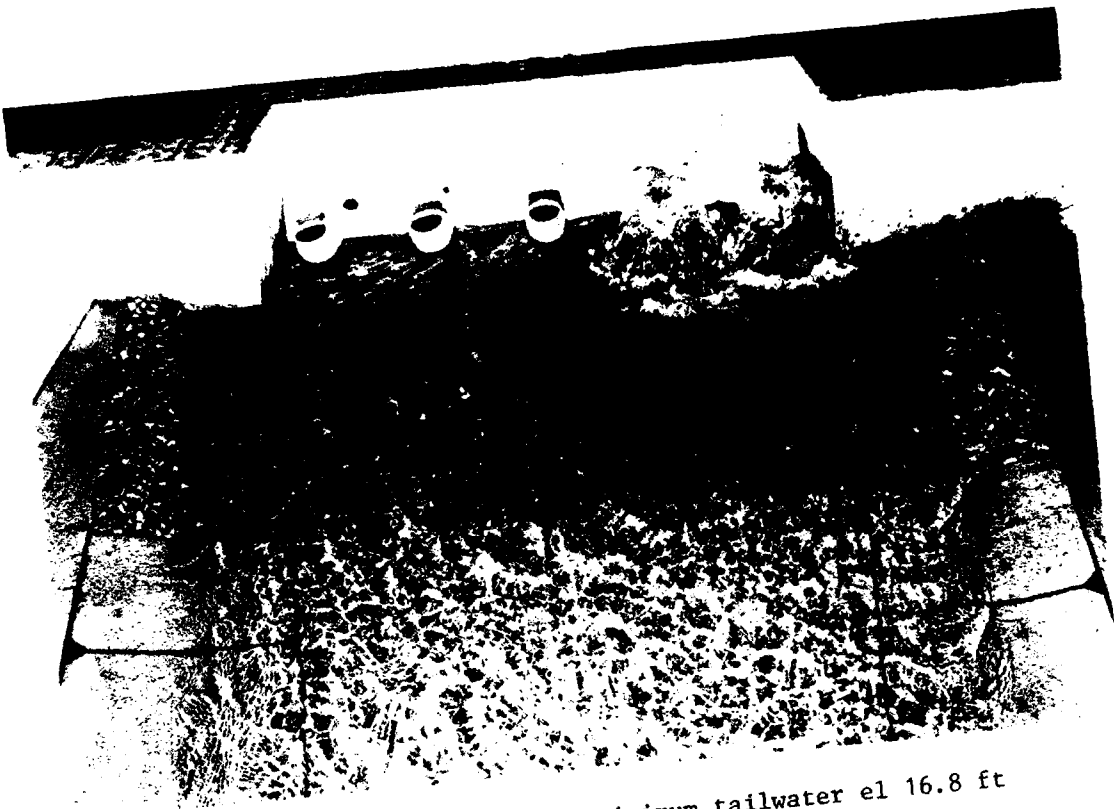

a. Two pumps discharging; minimum tailwater el 16.8 ft

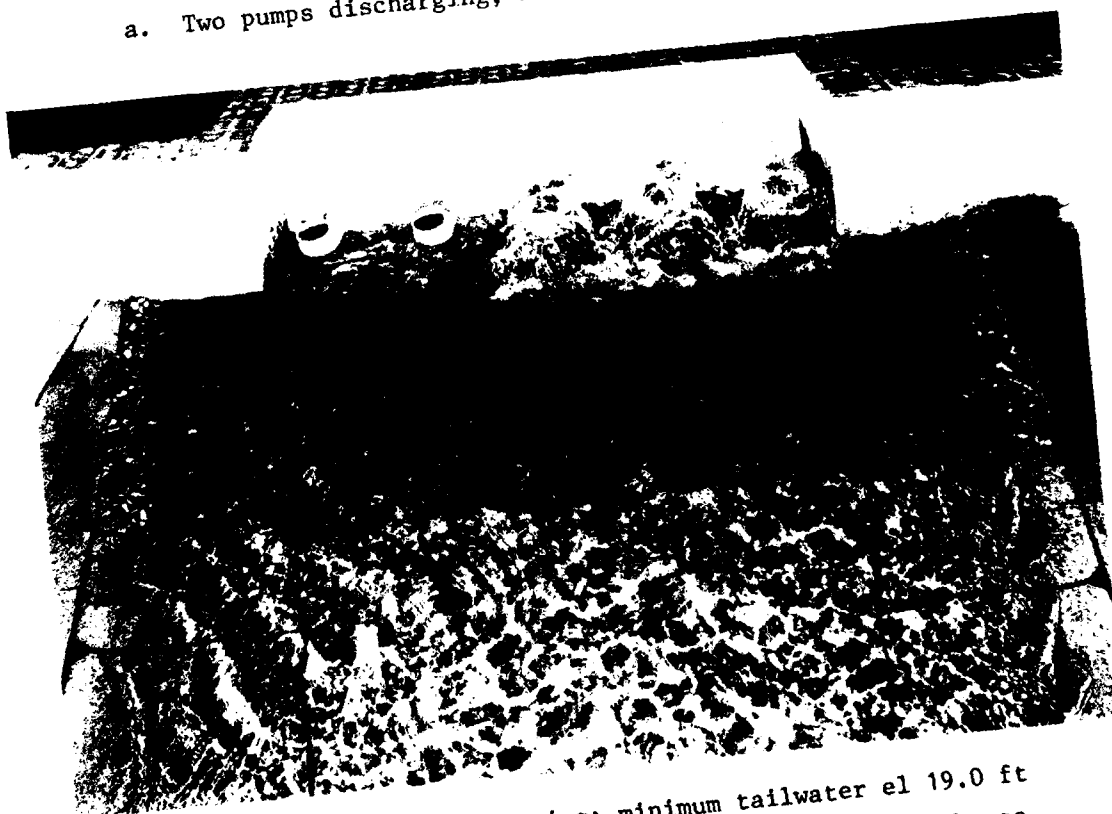

b. Three pumps discharging; minimum tailwater el 19.0 ft
Photo 2. Flow conditions with original design; discharge
280 cfs per pump (sheet 1 of 2)

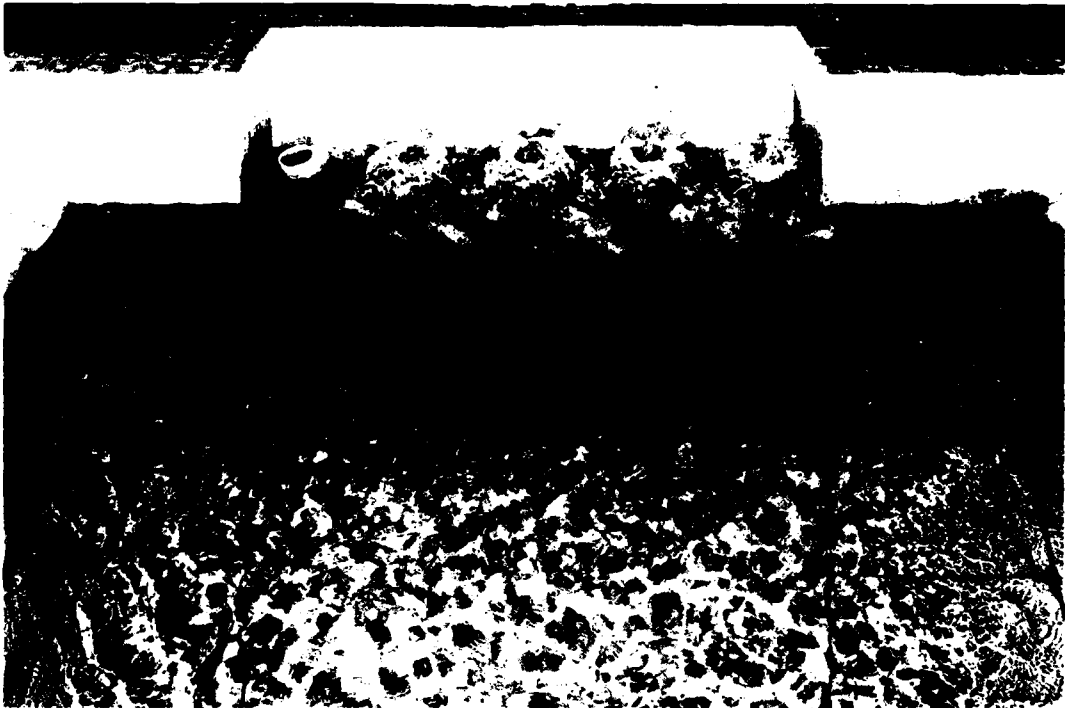

c. Four pumps discharging; minimum tailwater el 20.6 ft

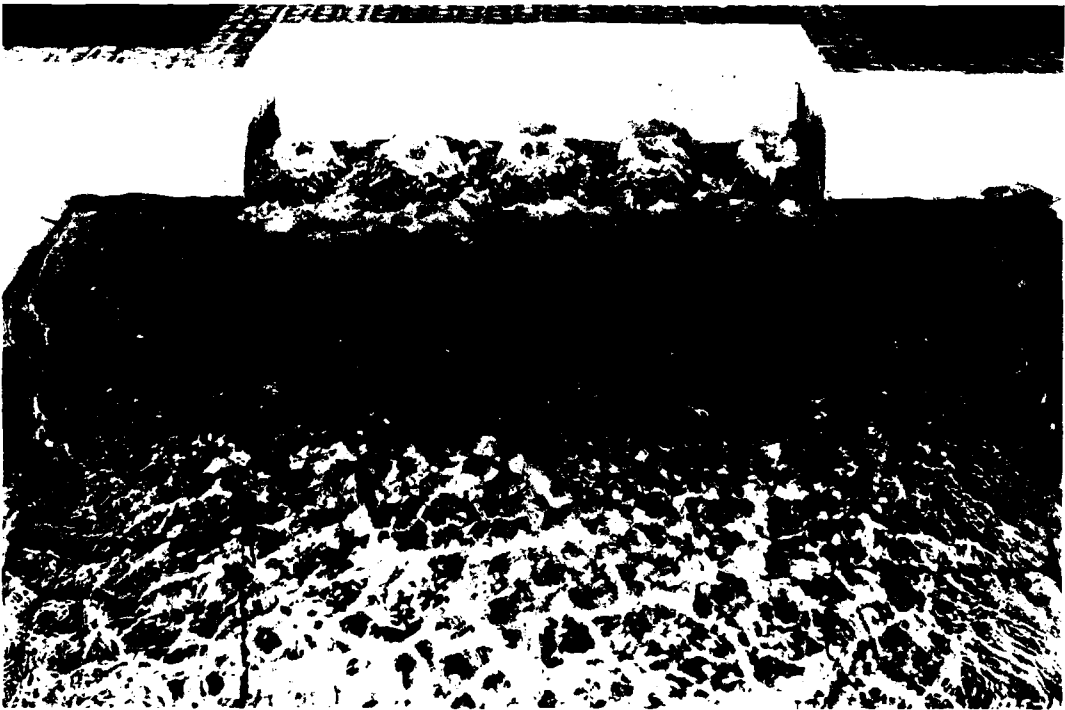

d. Five pumps discharging; minimum tailwater el 21.7 ft



a. One pump discharging; minimum tailwater el 14.5 ft



b. Two pumps discharging; minimum tailwater el 16.8 ft

Photo 3. Flow conditions with the type 2 design;
discharge 280 cfs per pump (sheet 1 of 3)

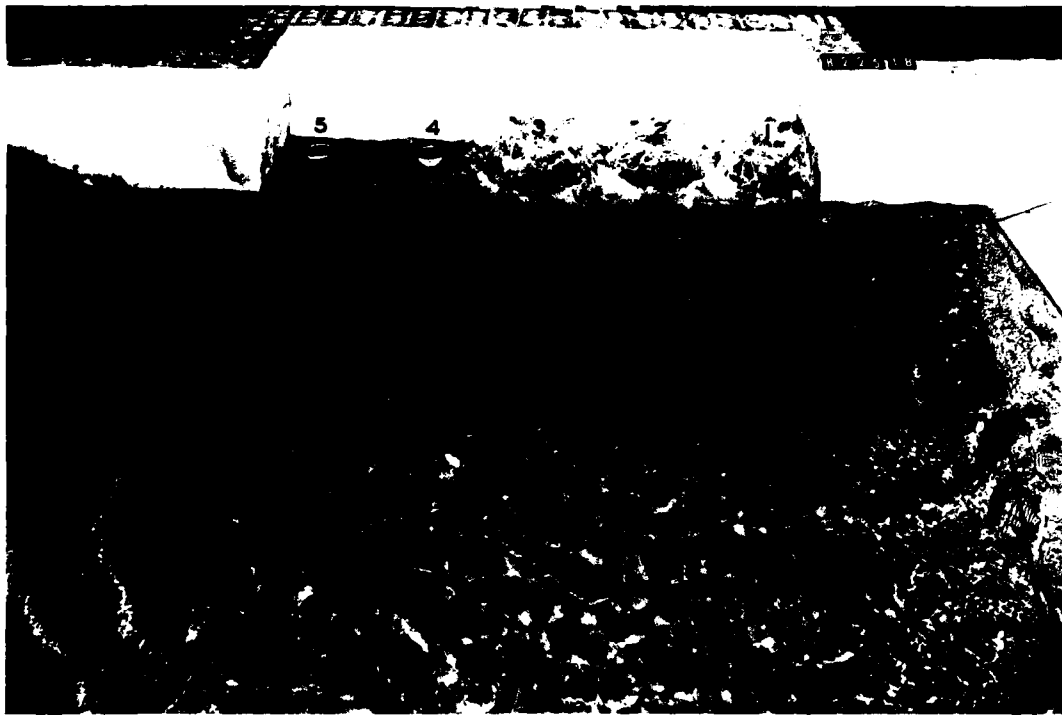

c. Three pumps discharging; minimum tailwater el 19.0 ft

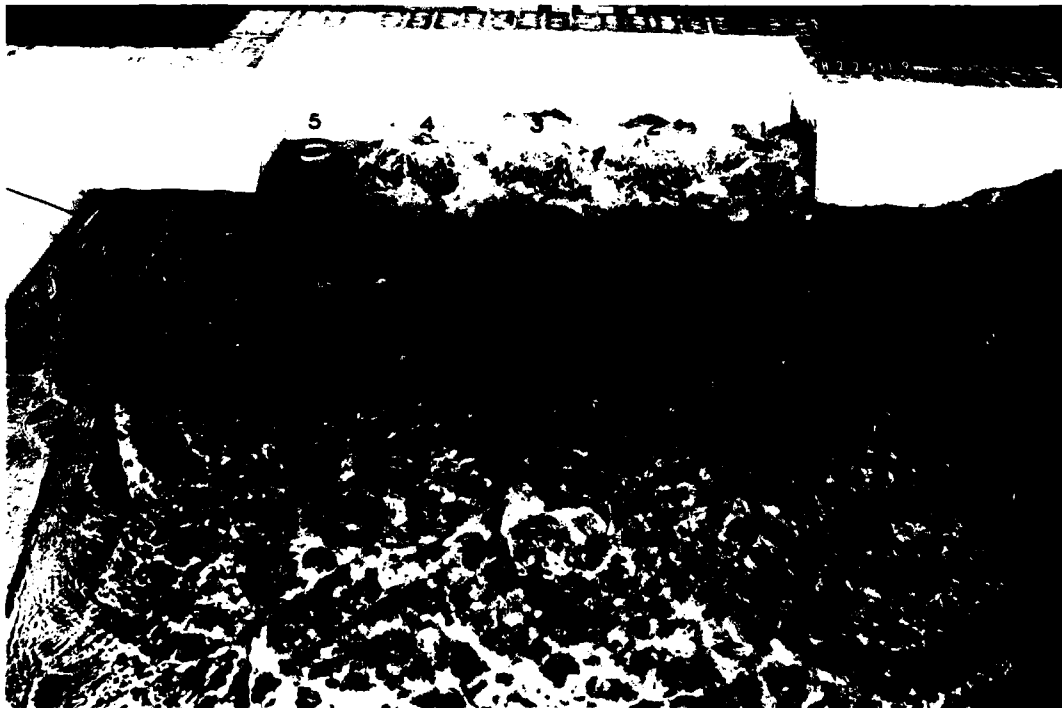

d. Four pumps discharging; minimum tailwater el 20.6 ft



e. Five pumps discharging; minimum tailwater el 21.7 ft

Photo 3 (sheet 3 of 3)

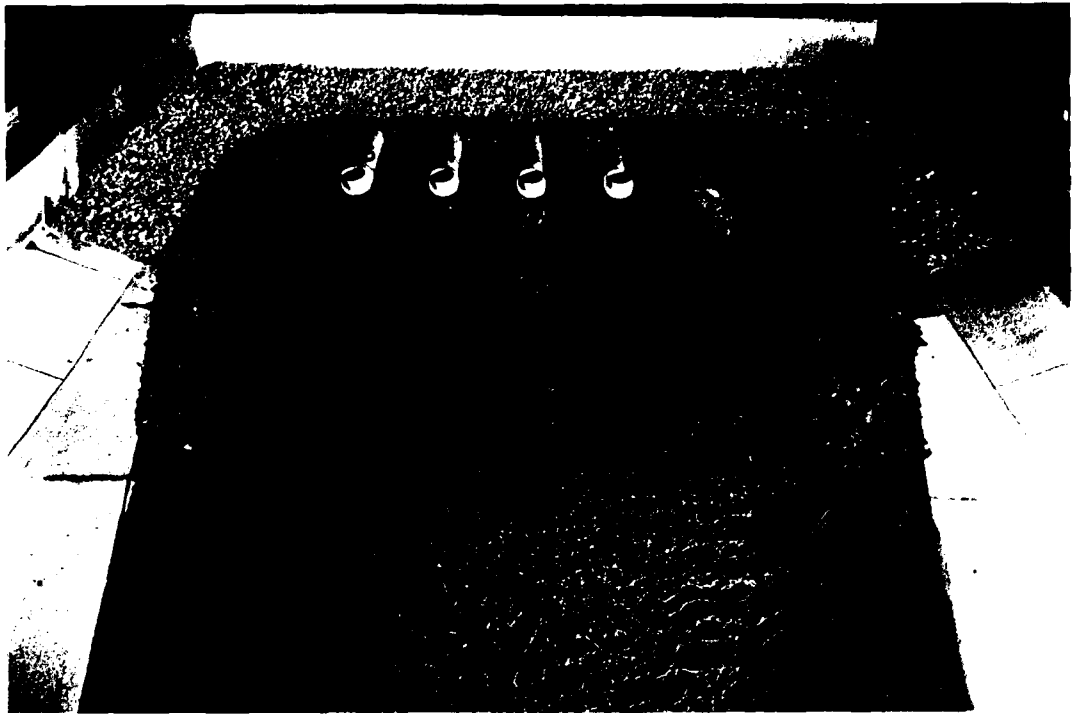

a. One pump discharging; minimum tailwater el 14.5 ft



b. Two pumps discharging; minimum tailwater el 16.8 ft

Photo 4. Flow conditions with the type 3 design;
discharge 280 cfs per pump (sheet 1 of 3)



c. Three pumps discharging; minimum tailwater el 19.0 ft



d. Four pumps discharging; minimum tailwater el 20.6 ft

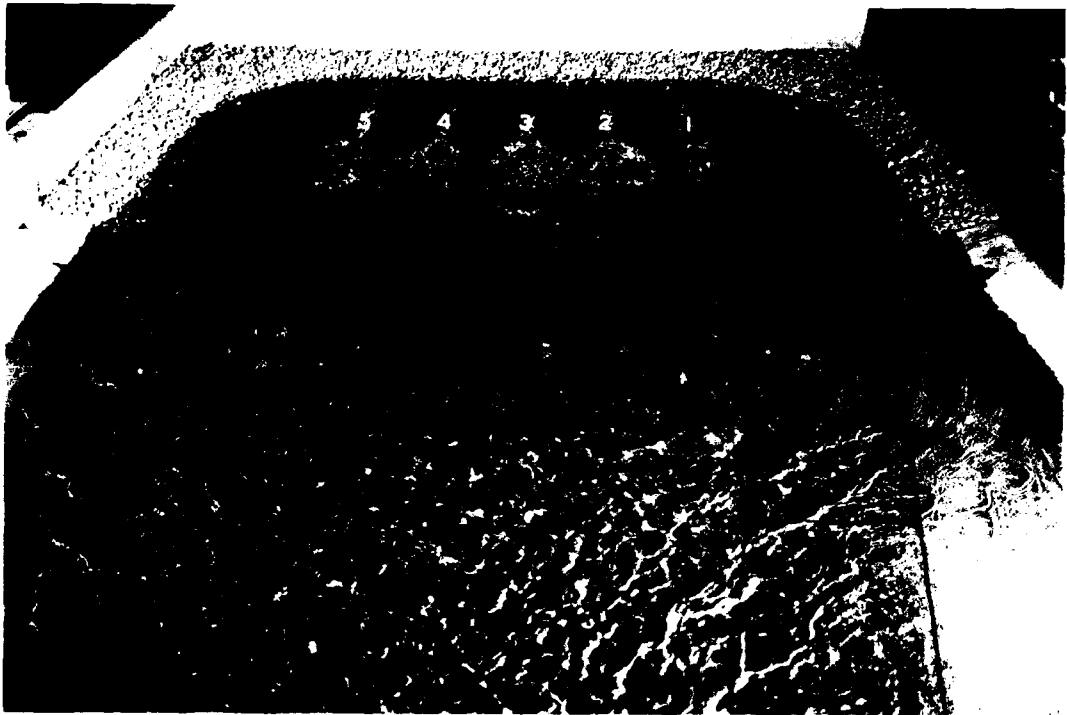

e. Five pumps discharging; minimum tailwater el 21.7 ft

Photo 4 (sheet 3 of 3)

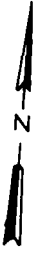
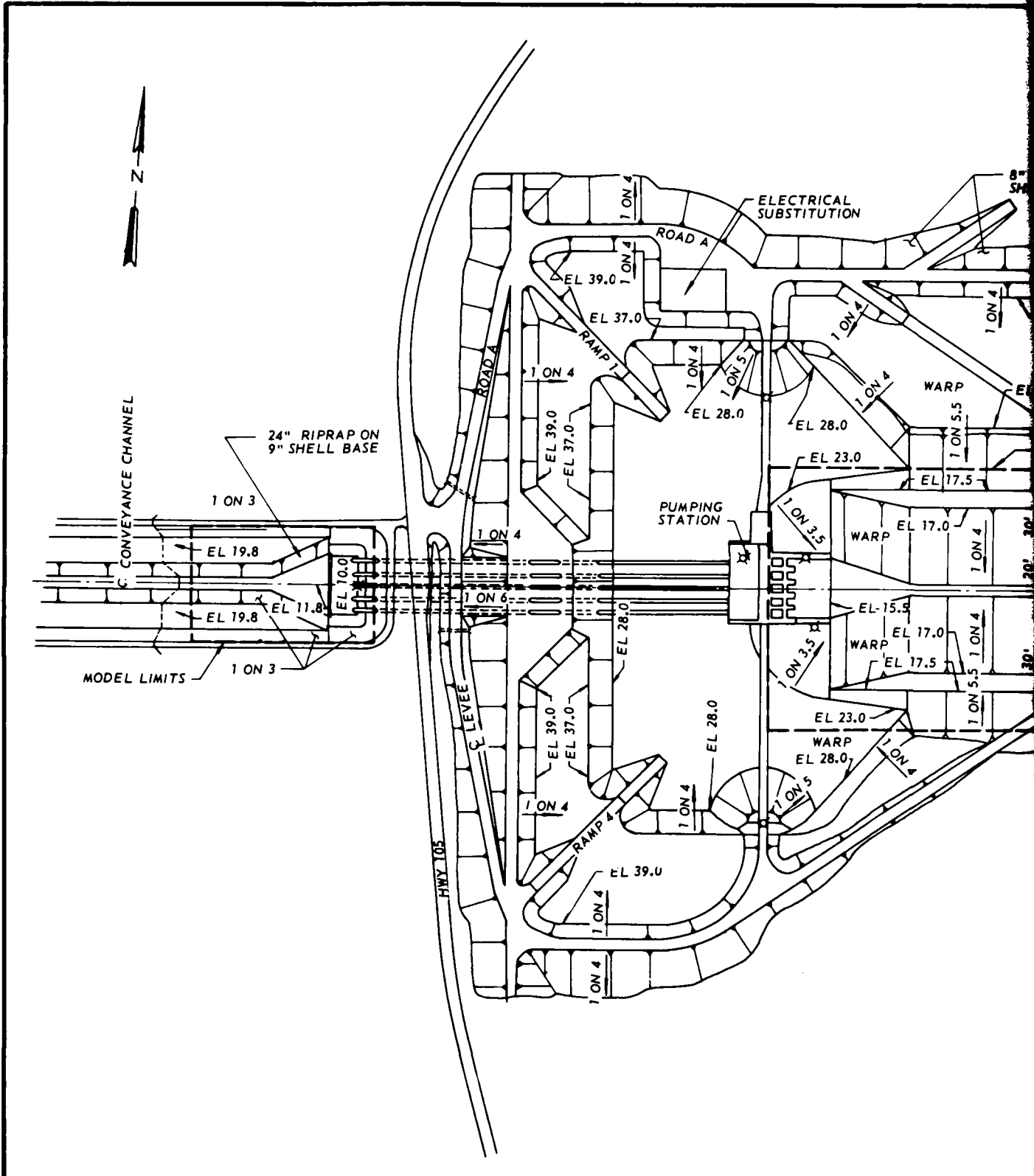

C. CONVEYANCE CHANNEL

24" RIPRAP ON 9" SHELL BASE

MODEL LIMITS

HWY 105

ELECTRICAL SUBSTITUTION

PUMPING STATION

ROAD A

ROAD A

RAMP A

RAMP B

WARP

WARP

WARP

WARP

1 ON 3

1 ON 3

1 ON 4

1 ON 6

1 ON 4

1 ON 4

1 ON 4

1 ON 4

1 ON 4

1 ON 5

1 ON 5

1 ON 4

1 ON 4

1 ON 3.5

1 ON 3.5

1 ON 4

1 ON 4

1 ON 4

1 ON 4

1 ON 4

1 ON 4

1 ON 4

1 ON 4

1 ON 4

N

N

N

N

N

N

N

N

N

N

N

N

N

N

N

N

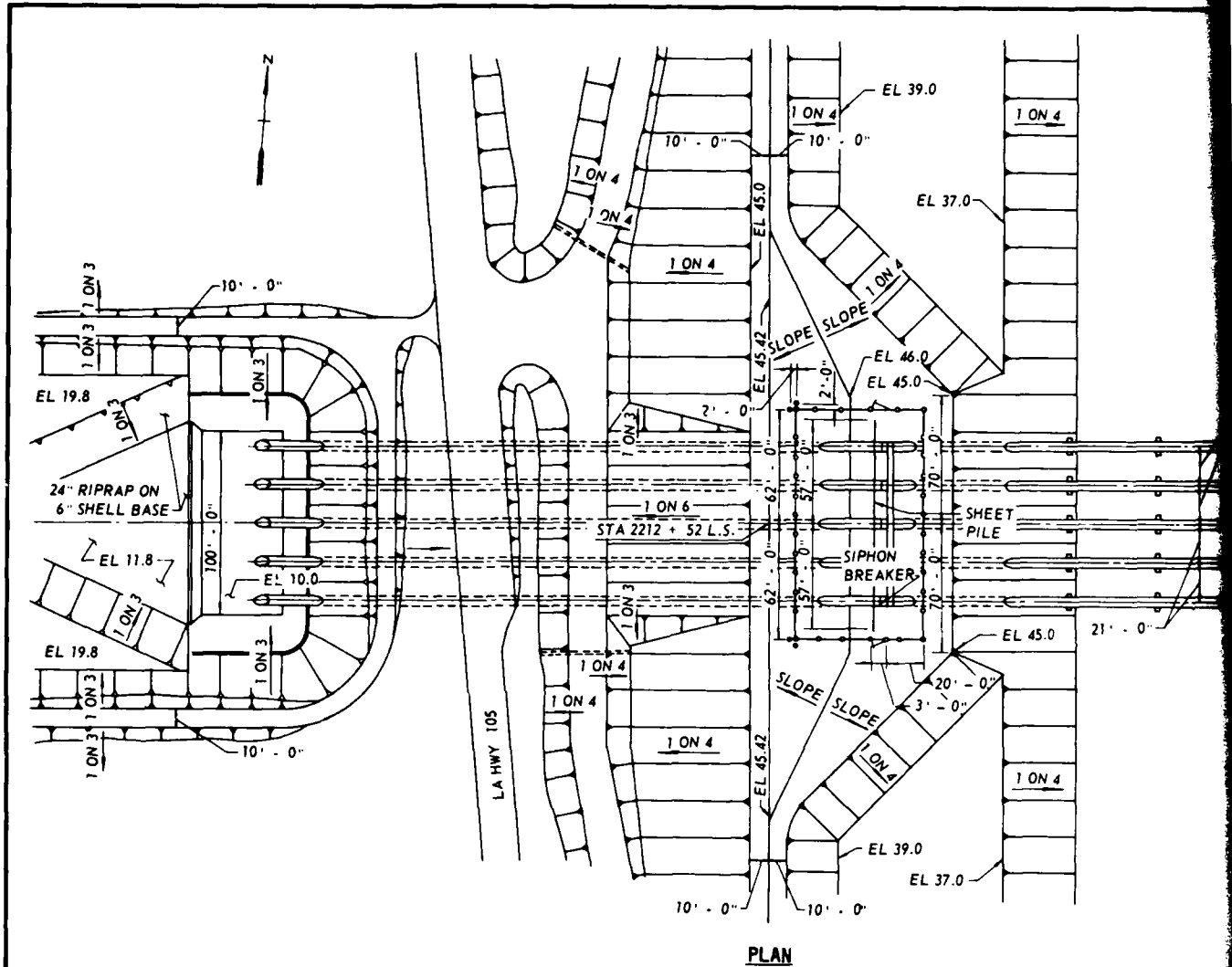

PLAN

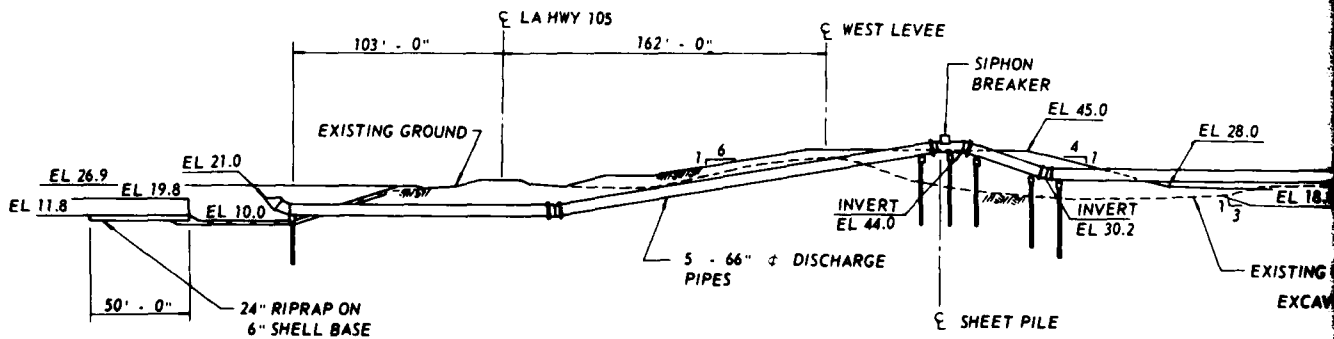

PROFILE

2

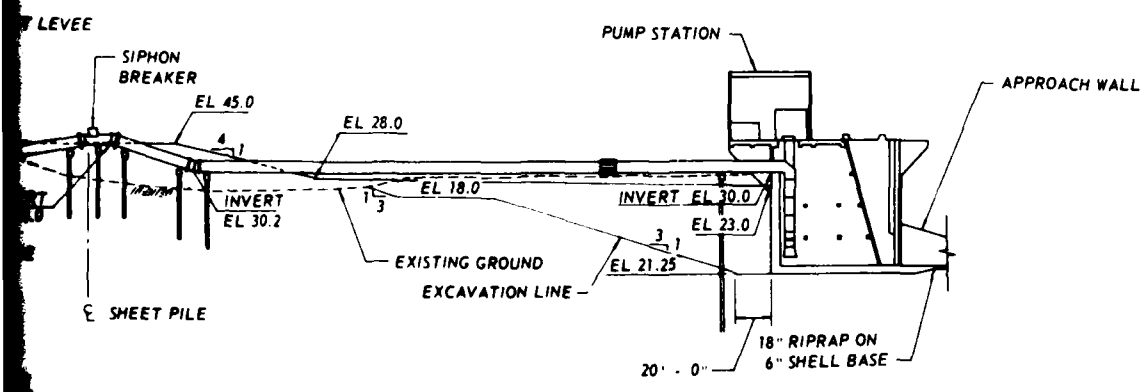
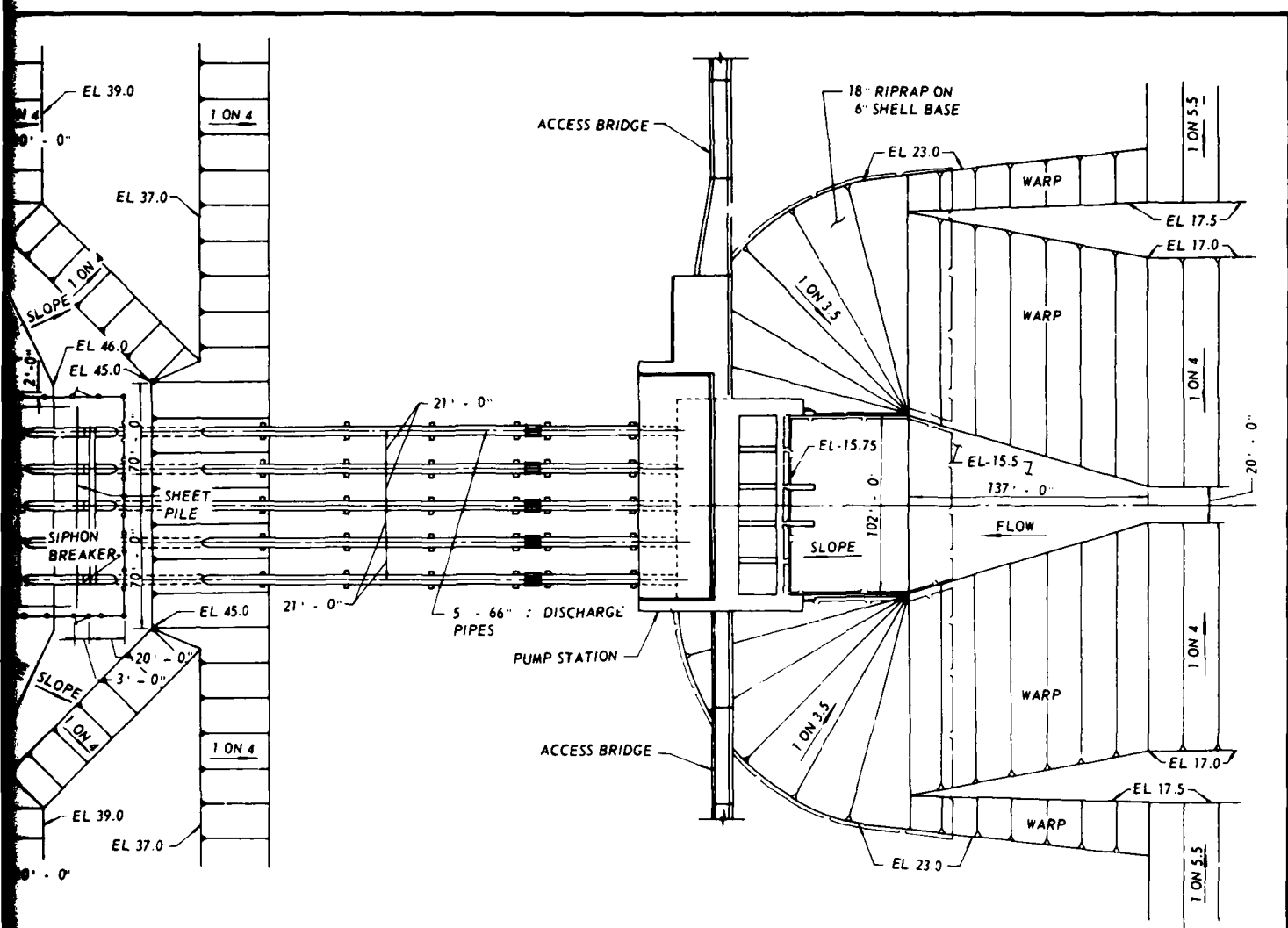

PLAN AND PROFILE
PROPOSED DESIGN

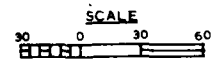

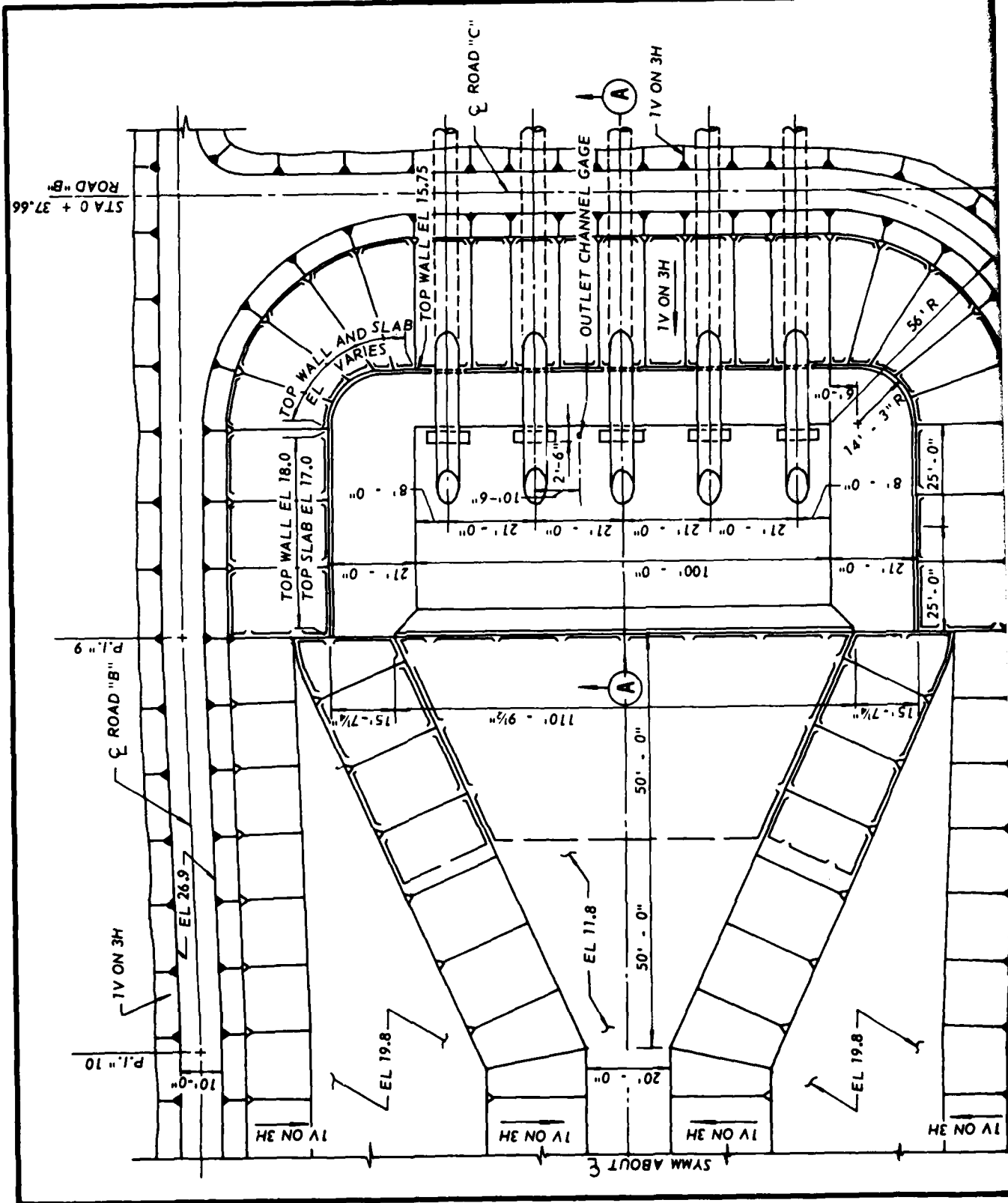

OUTLET STRUCTURE
PLAN AND PROFILE
PROPOSED DESIGN

SECTION A
SCALE
0 5 10 15 FT

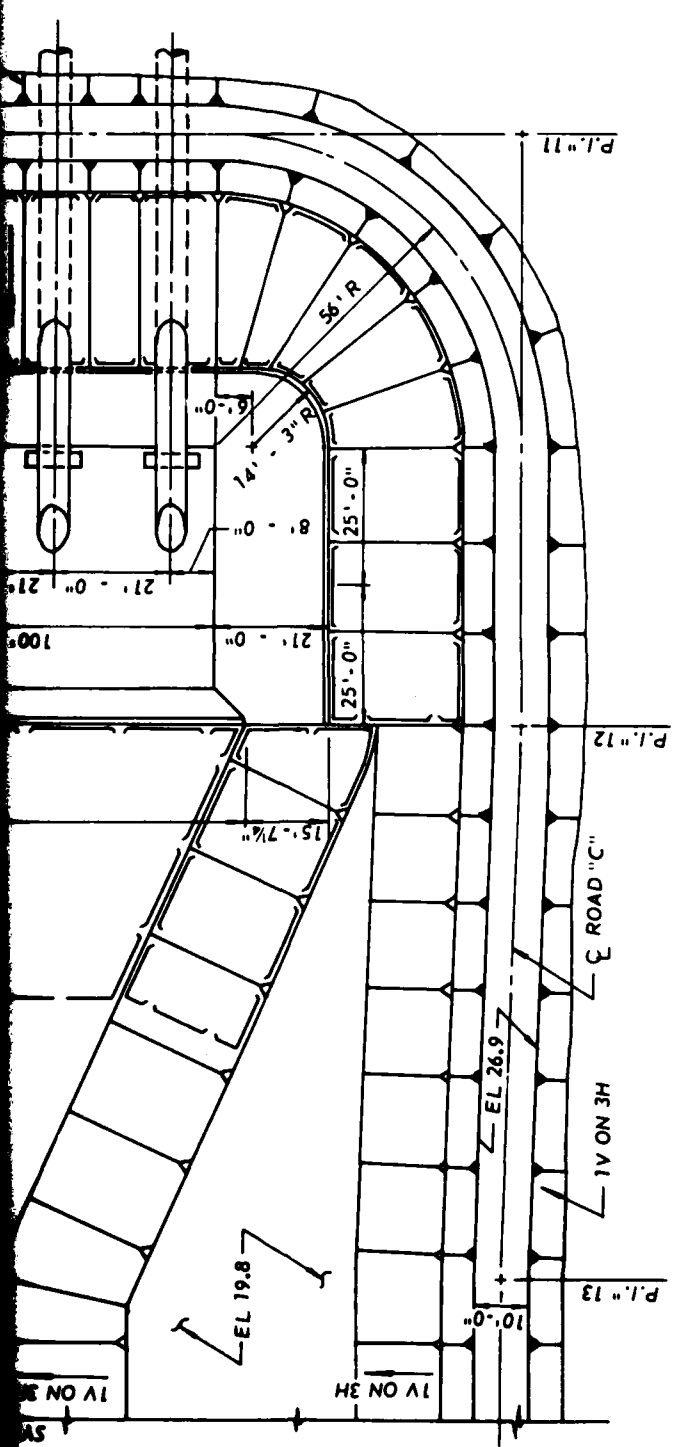

PLAN

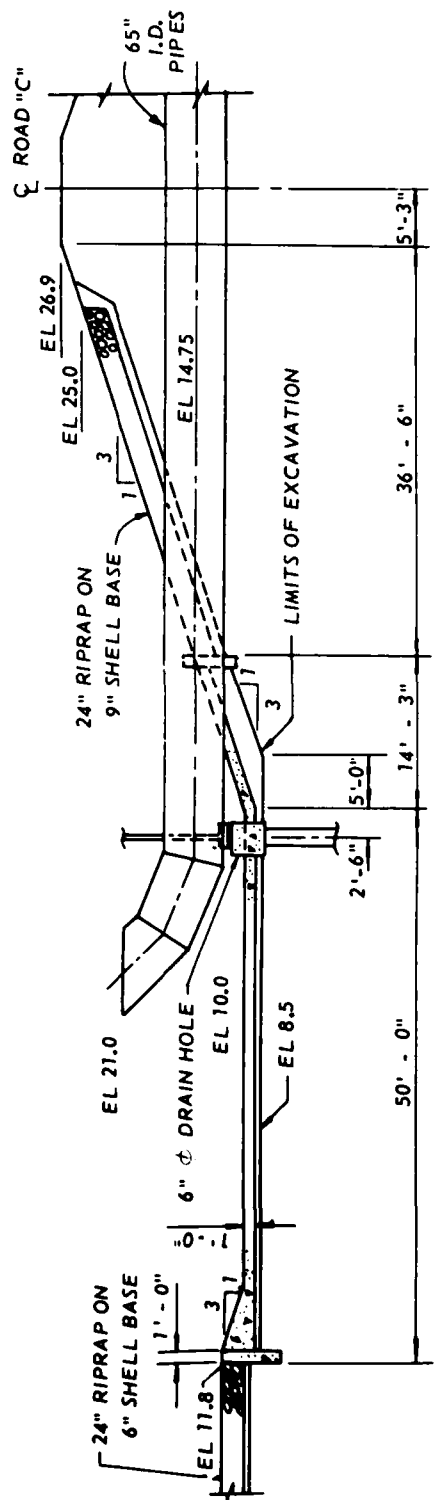
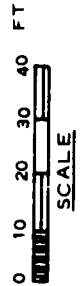

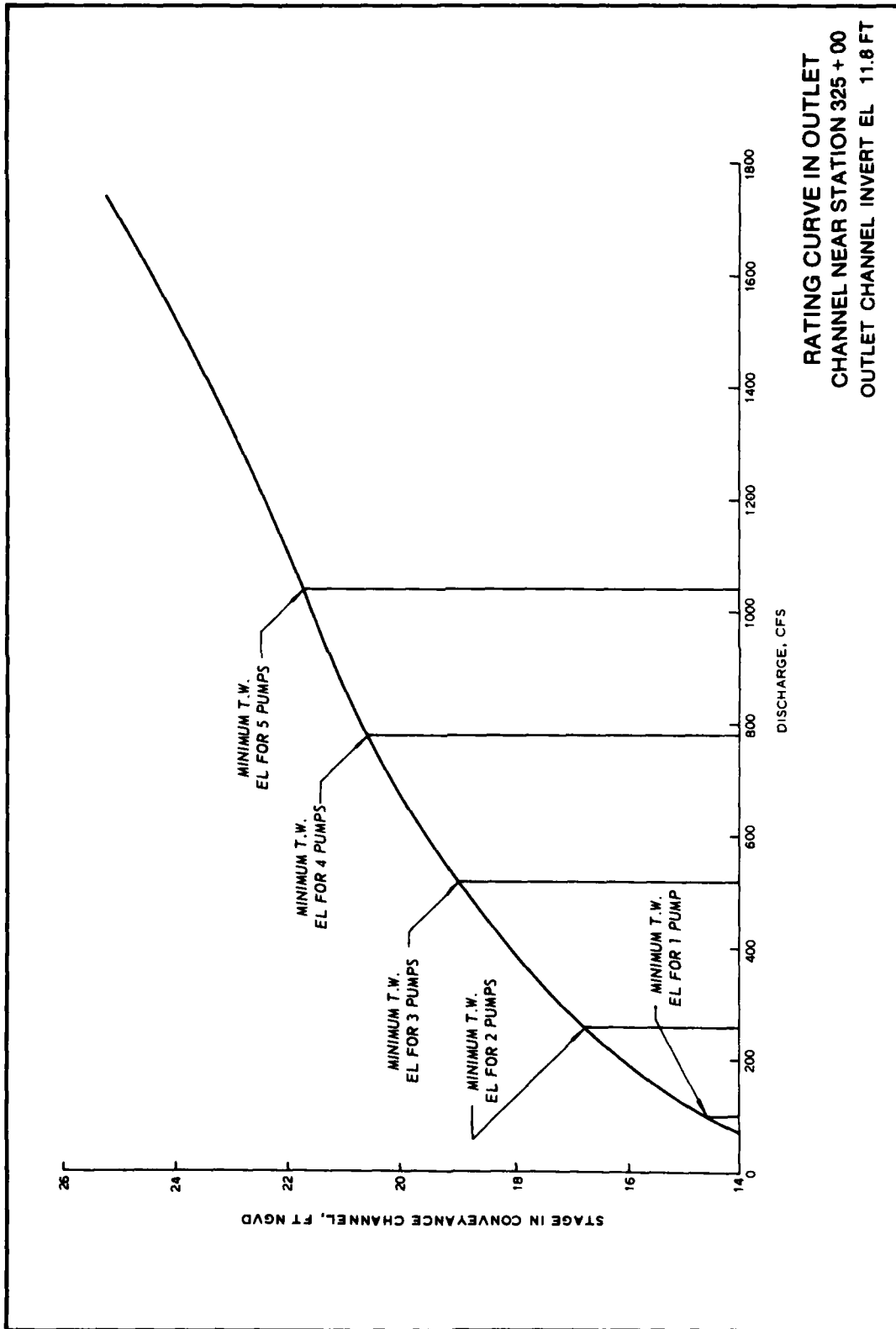
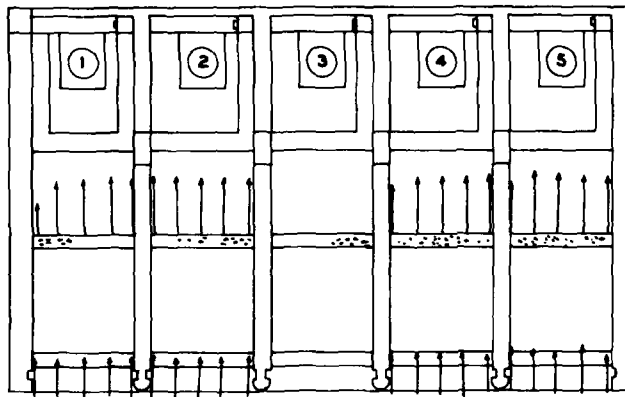
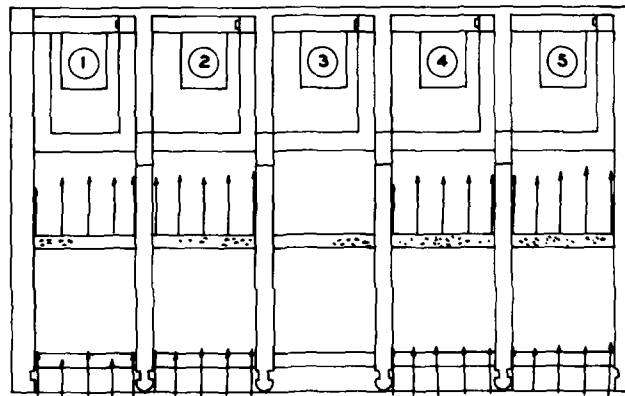

PLATE 5



WATER-SURFACE EL 36 FT



WATER-SURFACE EL 14 FT

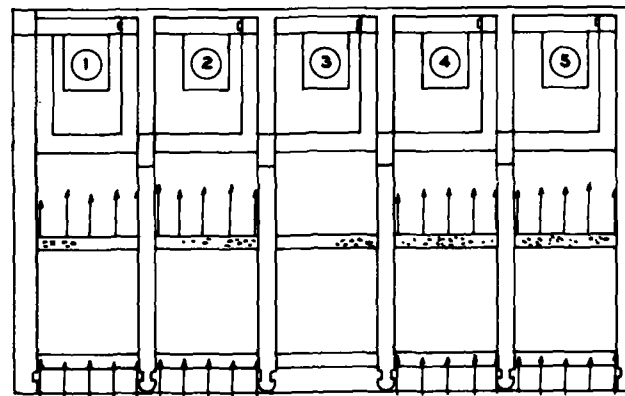

WATER-SURFACE EL 3 FT



BOTTOM VELOCITY DISTRIBUTION
PUMPS 1, 2, 4, AND 5 OPERATING
DISCHARGE 280 CFS PER PUMP

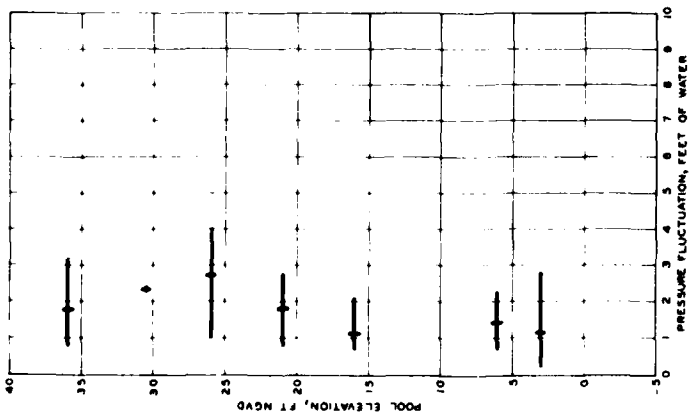

70-IN-DIAM BELL

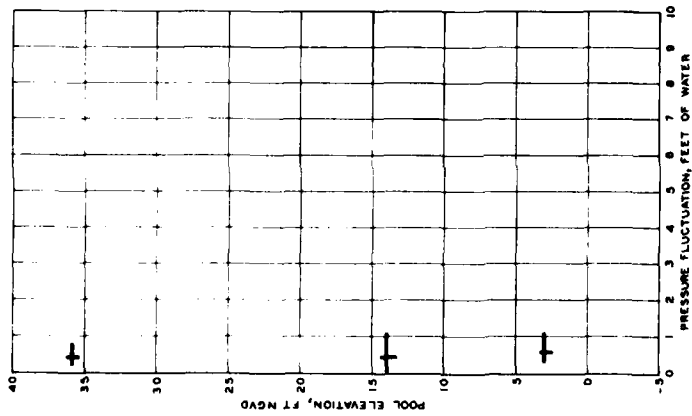

84-IN-DIAM BELL

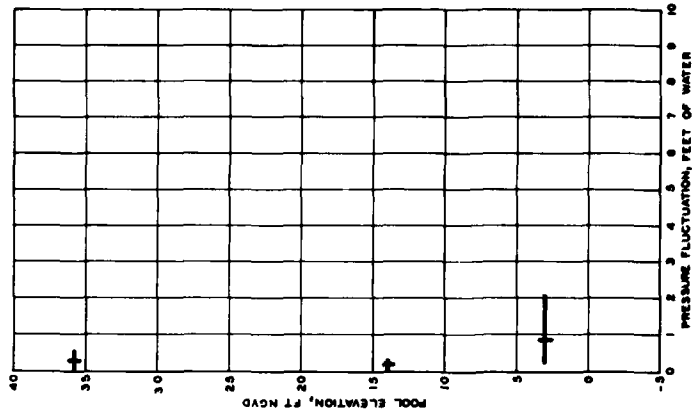



100-IN-DIAM BELL

MIN AVG MAX

NOTE PRESSURE FLUCTUATIONS INDICATED ARE MAXIMUM FLUCTUATION OBSERVED WITH VARIOUS COMBINATIONS OF PUMPS OPERATING

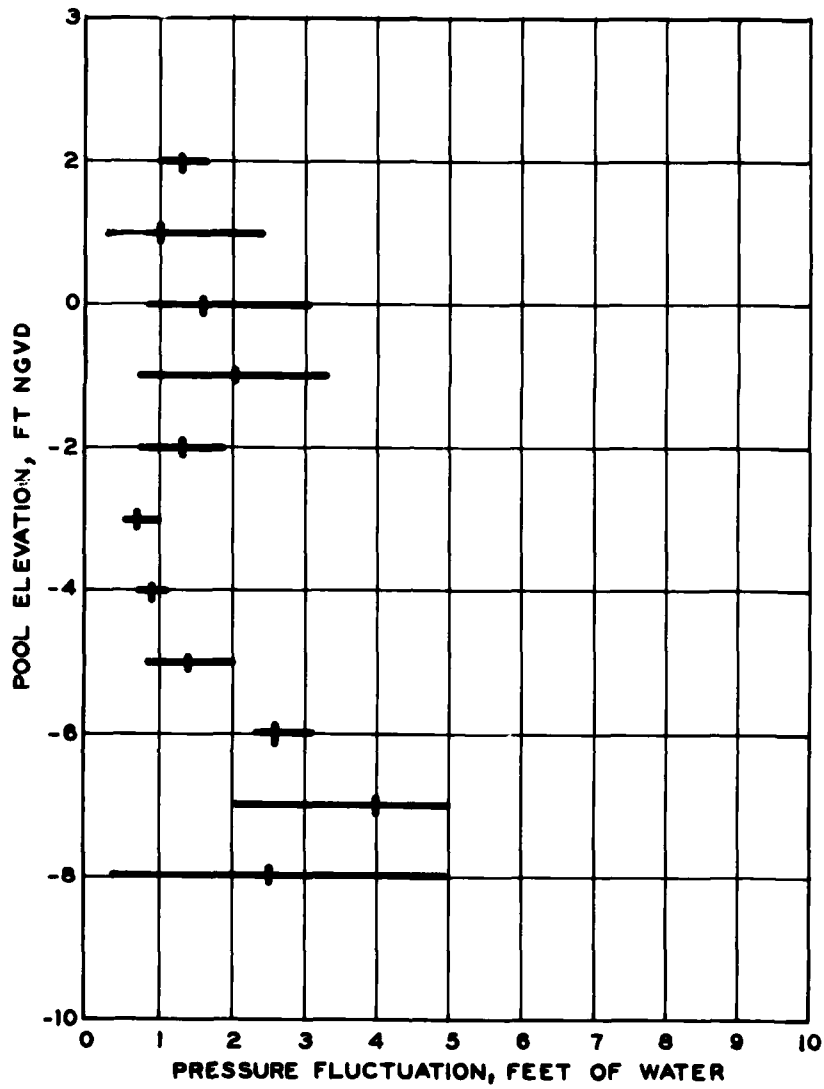
PRESSURE FLUCTUATION VS POOL ELEVATION
70-, 84-, AND 100-IN-DIAM BELLS
DISCHARGE 280 CFS PER PUMP



 MIN AVG MAX

NOTE: PRESSURE FLUCTUATIONS INDICATED
 ARE MAXIMUM FLUCTUATION OB-
 TAINED WITH VARIOUS COMBINATIONS
 OF PUMPS OPERATING

PRESSURE FLUCTUATION
 VS POOL ELEVATION
 70-IN.-DIAM BELL
 DISCHARGE 280 CFS PER PUMP

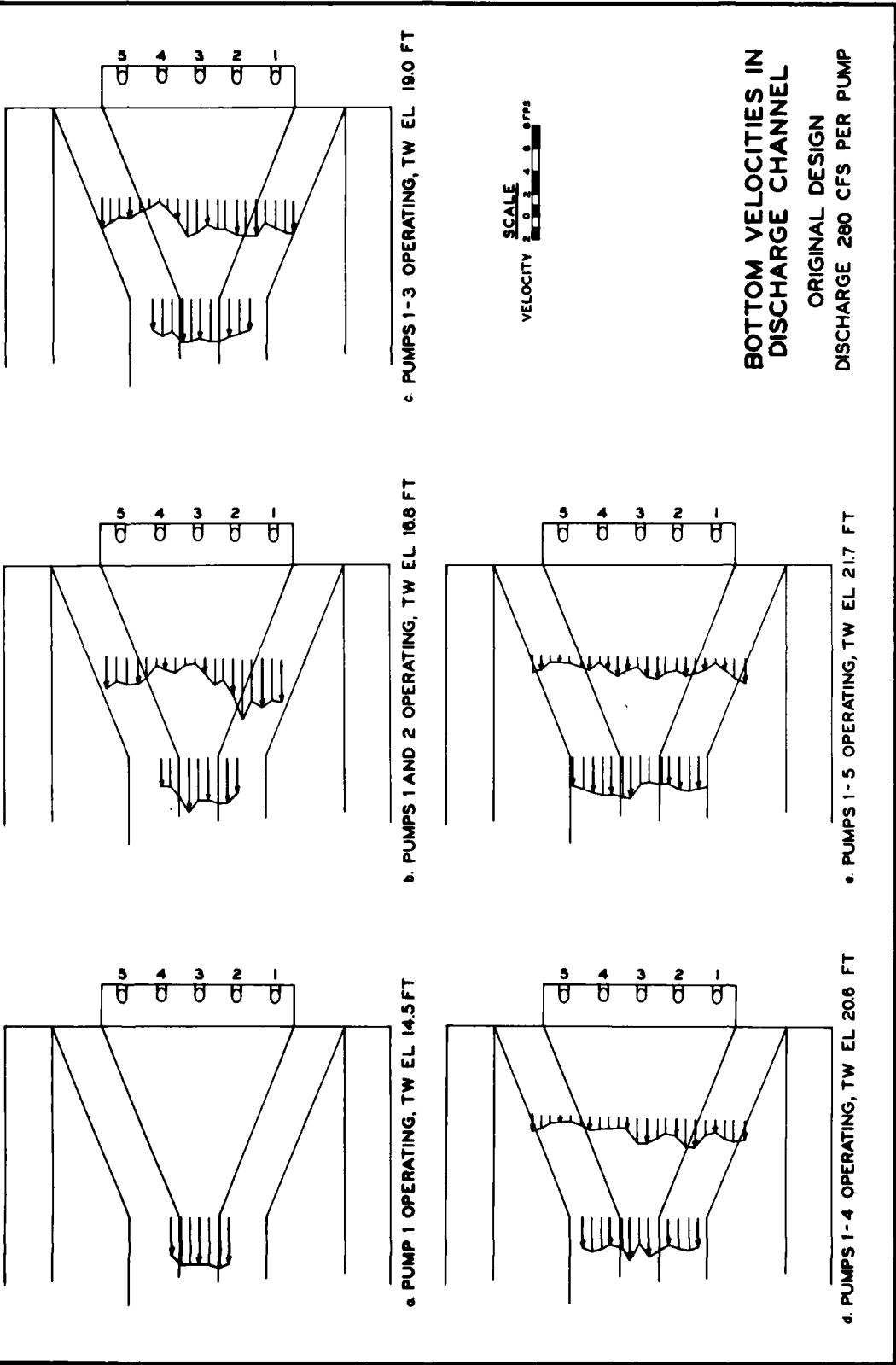

c. PUMPS 1-3 OPERATING, TW EL 19.0 FT

b. PUMPS 1 AND 2 OPERATING, TW EL 16.8 FT

a. PUMP 1 OPERATING, TW EL 14.5 FT

e. PUMPS 1-5 OPERATING, TW EL 21.7 FT

d. PUMPS 1-4 OPERATING, TW EL 20.6 FT

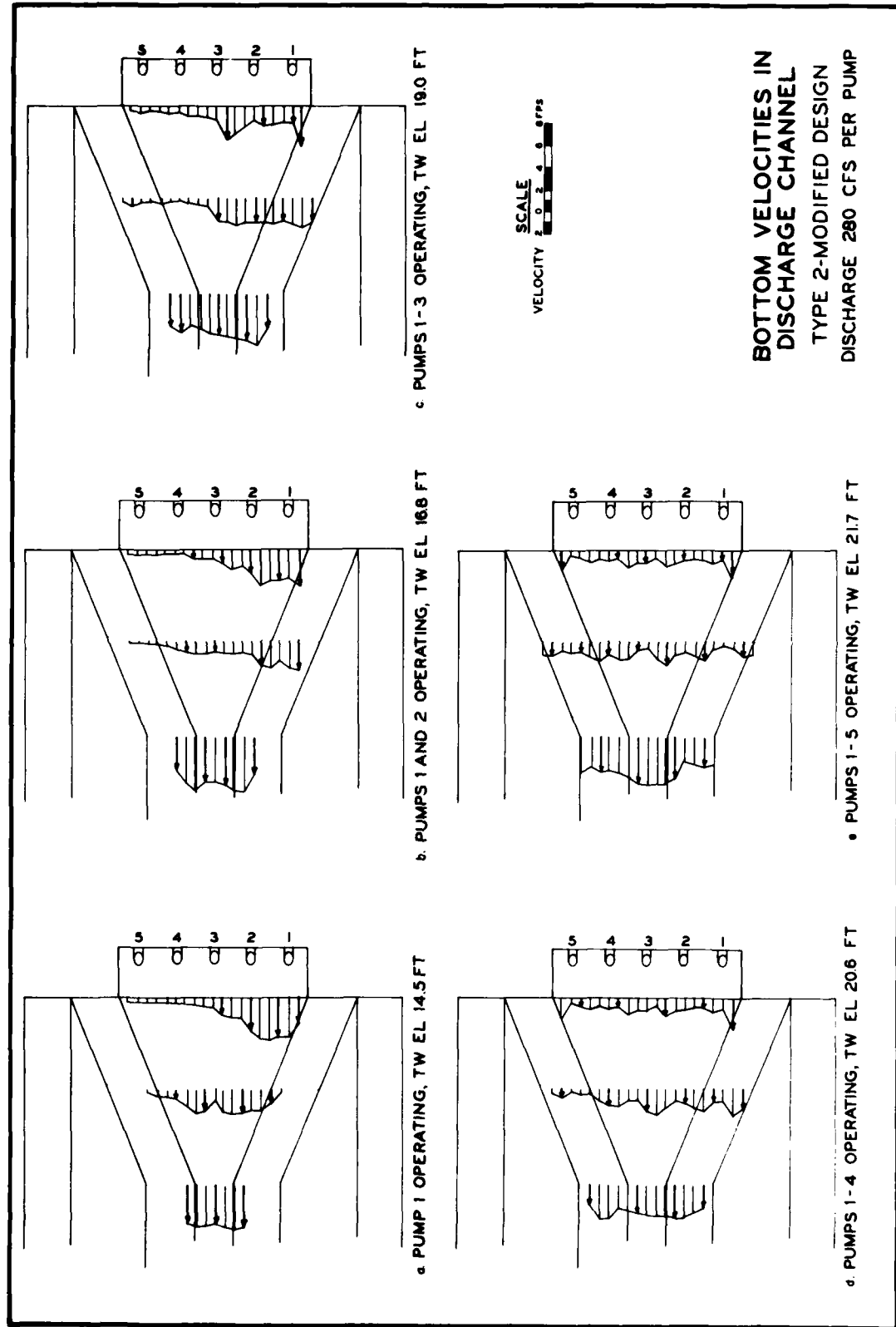
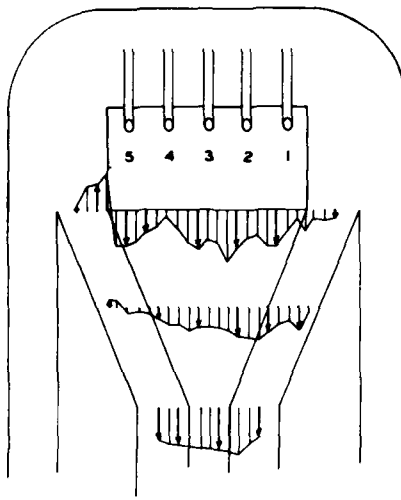
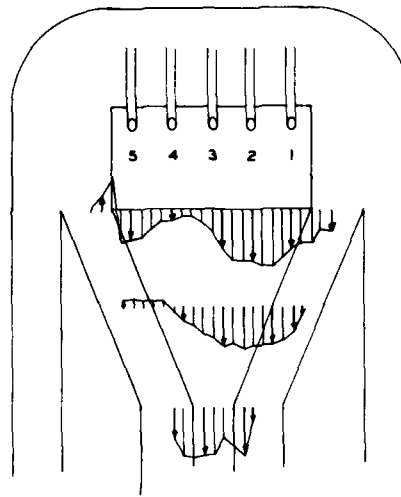

PLATE 10



c PUMPS 1-3 OPERATING, TW EL 190 FT



b PUMPS 1 AND 2 OPERATING, TW EL 168 FT

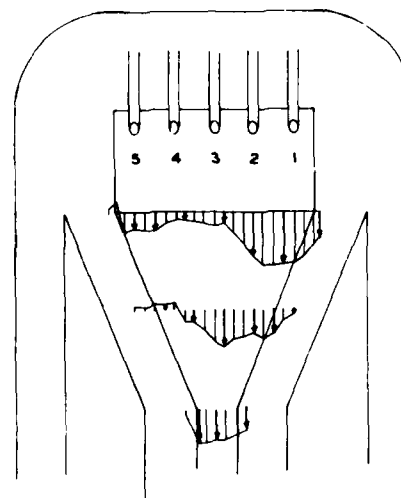

a PUMP 1 OPERATING, TW EL 14.5 FT

SCALE
VELOCITY 2 0 2 4 6 FPS

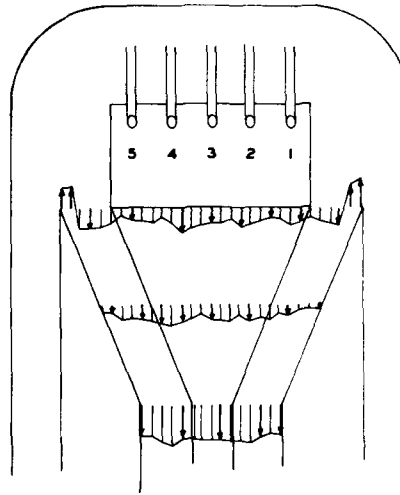

e PUMPS 1-5 OPERATING, TW EL 217 FT

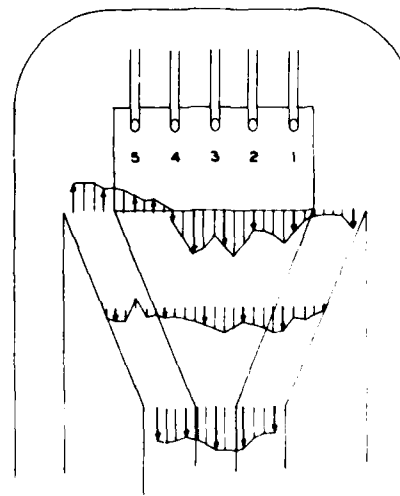

d PUMPS 1-4 OPERATING, TW EL 206 FT

**BOTTOM VELOCITIES IN
DISCHARGE CHANNEL
TYPE 3-MODIFIED
(RECOMMENDED DESIGN)
DISCHARGE 280 CFS PER PUMP**

In accordance with letter from DAEN-RDC, DAEN-ASI dated 22 July 1977, Subject: Facsimile Catalog Cards for Laboratory Technical Publications, a facsimile catalog card in Library of Congress MARC format is reproduced below.

Saunders, Peter E

Pumping station for Teche-Vermilion Basins, Atchafalaya River, Louisiana; hydraulic model investigation / by Peter E. Saunders, Bobby P. Fletcher. Vicksburg, Miss. : U. S. Waterways Experiment Station ; Springfield, Va. : available from National Technical Information Service, 1980.

21, [11] p., [8] leaves of plates : ill. ; 27 cm. (Technical report - U. S. Army Engineer Waterways Experiment Station ; HL-80-6)

Prepared for U. S. Army Engineer District, New Orleans, New Orleans, Louisiana.

1. Channel flow. 2. Hydraulic models. 3. Pumping stations. 4. Teche-Vermilion Basins. I. Fletcher, Bobby P., joint author. II. United States. Army. Corps of Engineers. New Orleans District. III. Series: United States. Waterways Experiment Station, Vicksburg, Miss. Technical report ; HL-80-6.
TA7.W34 no,HL-80-6

DATE
ILME