

AD-A085 269

WOODWARD-CLYDE CONSULTANTS PLYMOUTH MEETING PA F/G 13/13
NATIONAL DAM INSPECTION PROGRAM. MILL WATER DAM (NDS T.D. NUMBE--ETC(U)
MAR 80 M F BECK, J H FREDERICK DACW31-80-C-001A
NL

UNCLASSIFIED

1 of 1
AD
A085 269



END
DATE
FILMED
6-80
DTIC

ADA 085269

WOODWARD-CLYDE CONSULTANTS

DACW31-80-C-0018

This document has been approved
for public release and sale; its
distribution is unlimited.

DISCLAIMER NOTICE

**THIS DOCUMENT IS BEST QUALITY
PRACTICABLE. THE COPY FURNISHED
TO DTIC CONTAINED A SIGNIFICANT
NUMBER OF PAGES WHICH DO NOT
REPRODUCE LEGIBLY.**

①

SUSQUEHANNA RIVER BASIN

⑥

National Dam Inspection Program

BACK CREEK

MILL WATER DAM

BERKS COUNTY, PENNSYLVANIA

(NDS I.D. NO. PA 00703,
DER I.D. NO. 6-442)

Back Creek, Berks County, Pennsylvania

PHASE I INSPECTION REPORT
NATIONAL DAM INSPECTION PROGRAM

⑩ Mary F. Root /
John Henry / Fredrick Jr /

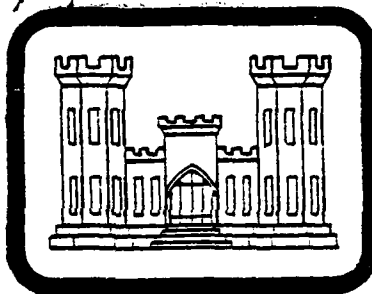

DTIC
ELECTE
JUN 9 1980

12/84

Prepared by:

WOODWARD-CLYDE CONSULTANTS
5120 Butler Pike
Plymouth Meeting, Pennsylvania 19462

15 [Handwritten initials]

Submitted to:

DEPARTMENT OF THE ARMY
Baltimore District, Corps of Engineers
Baltimore, Maryland 21203

⑪ March 1980

This document has been approved
for public release and sale; its
distribution is unlimited.

5012

PREFACE

This report is prepared under guidance contained in the Recommended Guidelines for Safety Inspection of Dams for Phase I Investigations. Copies of these guidelines may be obtained from the Office of the Chief of Engineers, Washington, D.C. 20314. The purpose of a Phase I investigation is to expeditiously identify those dams which may pose hazards to human life or property. The assessment of the general condition of the dam is based upon available data and visual inspections. Detailed investigations, testing and detailed computational evaluations are beyond the scope of a Phase I investigation; however, the investigation is intended to identify the need for more detailed studies.

In reviewing this report, it should be realized that the reported condition of the dam is based on observations of field conditions at the time of inspection along with data available to the inspection team. In cases where the reservoir was lowered or drained prior to inspection, such action, while improving the stability and safety of the dam, removes the normal load on the structure and may obscure certain conditions which might otherwise be detectable if inspected under the normal operating environment of the structure.

It is important to note that the condition of a dam depends on numerous and constantly changing internal and external conditions, and is evolutionary in nature. It would be incorrect to assume that the present condition of the dam will continue to represent the condition of the dam at some point in the future. Only through frequent inspections can unsafe conditions be detected, and only through continued care and maintenance can these conditions be prevented or corrected.

Phase I inspections are not intended to provide detailed hydrologic and hydraulic analyses. In accordance with the established Guidelines, the spillway design flood is based on the estimated "Probable Maximum Flood" for the region (greatest reasonably possible storm runoff), or fractions thereof. The spillway design flood provides a measure of relative spillway capacity and serves as an aid in determining the need for more detailed hydrologic and hydraulic studies, considering the size of the dam, its general condition and the downstream damage potential.

Accession For	
NTIS GWS&I	<input checked="" type="checkbox"/>
DDC TAB	<input type="checkbox"/>
Unannounced	<input type="checkbox"/>
Justification	<i>for</i>
By	<i>for</i>
Distribution	
Availability	
Dist	Available for special
<i>A</i>	<i>23</i> <i>9</i>

PHASE I INSPECTION REPORT
NATIONAL DAM INSPECTION PROGRAM

Name of Dam: Mill Water Pond Dam
County Located: Berks County
State Located: Pennsylvania
Stream: Back Creek
Coordinates: Latitude 40° 9.9'
Longitude 75° 52.6'
Date of Inspection: November 15, 1979

Mill Water Pond Dam is owned by the Bethlehem Mines Corporation. The dam was originally built as an industrial water supply dam for the Grace Mine. As the mine is no longer in operation, water from the reservoir is no longer used.

The dam and its appurtenant facilities are considered to be in good condition. The dam is classified as a "Small" size structure with a "High" hazard classification, consistent with the dam's location immediately above an occupied dwelling and above commercial buildings and other residences farther downstream on Conestoga Creek.

In accordance with criteria established by Federal (OCE) Guidelines, the spillway design flood for this "Small" size dam and "High" hazard classification is one-half to the full Probable Maximum Flood (PMF). As the dam height and total capacity are near the lower limit of the size classification, the selected spillway design flood is one-half the PMF.

Mining of the deep iron ore body has caused extensive subsidence. The mine waste rock is disposed of downstream of the subsidence area. Therefore, currently, Mill Water Pond intercepts surface runoff only from about 0.31 square mile immediately above the dam. Hydrologic and hydraulic computations presented in Appendix D indicate the maximum spillway capacity is greater than the peak PMF inflow from the reduced watershed. Therefore, the spillway system of this structure is considered to be "Adequate".

It is recommended that the following measures be undertaken as soon as practical.

1. The brush on the upstream and downstream slopes of the embankment should be cut on an annual basis.

The two small pine trees noted on the downstream embankment should be removed and the embankment restored to its original condition.

2. The seepage noted downstream of the embankment should be monitored at least visually on a regular basis. Any significant increase in seepage amount or development of turbidity should be evaluated by a registered professional engineer experienced in the design and construction of dams.

The following measure should be undertaken immediately.

3. The highway bridge over the spillway channel should be inspected by a PennDOT engineer to assess the need for repairs.

Because of the location of the dam above an occupied residence, with the potential for loss of life in the event of failure and excessive property damage farther downstream along Conestoga Creek, a formal procedure of observation and warning during periods of high precipitation should be developed and implemented. This procedure should include a method of warning downstream residents and industries if high flows are expected and provisions for evacuating these people in the event of an emergency. In addition, an operation and maintenance procedure should also be developed to insure that all pertinent items are carefully inspected on a regular basis and maintained in the best possible condition.

Mary F. Beck
Mary F. Beck, P.E.
Pennsylvania Registration No. 3747E
Woodward-Clyde Consultants

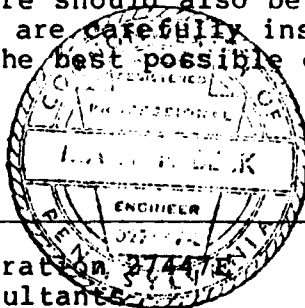

3/14/80
Date

John H. Frederick, Jr.
John H. Frederick, Jr., P.E.
Maryland Registration No. 7301
Woodward-Clyde Consultants



3/14/80
Date

APPROVED BY:

James W. Peck
JAMES W. PECK
Colonel, Corps of Engineers
District Engineer

25 APR 80
Date

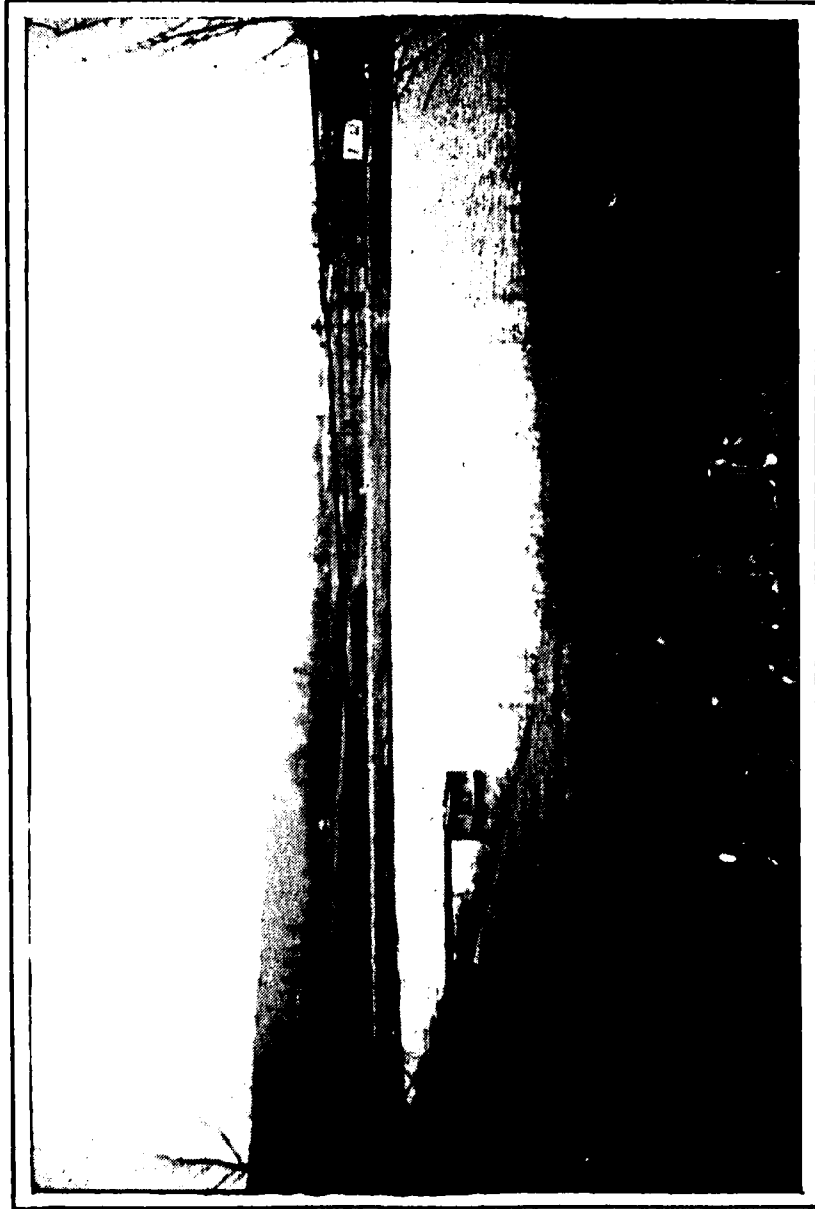

OVERVIEW
MILL WATER POND DAM, BERKS COUNTY, PENNSYLVANIA

TABLE OF CONTENTS

	<u>PAGE</u>
Preface	i
Assessment and Recommendations	ii
Overview Photograph	iv
SECTION 1 - PROJECT INFORMATION	
1.1 General	1
1.2 Description of Project	1
1.3 Pertinent Data	3
SECTION 2 - ENGINEERING DATA	
2.1 Design	5
2.2 Construction	5
2.3 Operational Data	5
2.4 Evaluation	5
SECTION 3 - VISUAL INSPECTION	
3.1 Findings	6
3.2 Evaluation	8
SECTION 4 - OPERATIONAL PROCEDURES	
4.1 Procedures	9
4.2 Maintenance of the Dam	9
4.3 Maintenance of Operating Facilities	9
4.4 Warning Systems In Effect	9
4.5 Evaluation	9
SECTION 5 - HYDROLOGY/HYDRAULICS	
5.1 Evaluation of Features	10
SECTION 6 - STRUCTURAL STABILITY	
6.1 Evaluation of Structural Stability	12
SECTION 7 - ASSESSMENT/REMEDIAL MEASURES	
7.1 Dam Assessment	13
7.2 Remedial Measures	13
APPENDIX	
A Visual Inspection	
B Engineering Data, Design, Construction and Operation	
C Photographs	
D Hydrology/Hydraulics	
E Plates	
F Geology	

PHASE I INSPECTION REPORT
NATIONAL DAM INSPECTION PROGRAM
MILL WATER POND DAM
NATIONAL ID NO. PA 00703
DER NO. 6-442

SECTION 1
PROJECT INFORMATION

1.1 General.

a. Authority. The Dam Inspection Act, Public Law 92-367, authorized the Secretary of the Army, through the Corps of Engineers, to initiate a program of inspection of dams throughout the United States.

b. Purpose. The purpose of the inspection is to determine if the dam constitutes a hazard to human life or property.

1.2 Description of Project.

a. Dam and Appurtenances. Mill Water Pond Dam is a zoned earth dam about 26 feet high and 440 feet long. The select impervious fill central core has side slopes of 1H:1V and a top width of 15 feet. The downstream and upstream zones are of run-of-bank fill with slopes of 2.5H:1V and 3H:1V, respectively. The top width of the dam is 20 feet. Under the upstream zone, the impervious fill material extends from the core to the reservoir, with a thickness of four feet at the core grading to two feet at the upstream toe. A one foot thick blanket of impervious materials overlies the entire reservoir floor. A three foot thick layer of dumped riprap choked with crushed stone or gravel is placed over a one foot layer of crushed stone or gravel on the upstream slope. The dam has no cutoff trench or grout curtain under it. The right end of the dam abuts to the shoulder of PA Route 10, and the south side of the reservoir is also bounded by the highway. Adjacent to the reservoir, the highway is on natural ground.

The spillway for the reservoir is located under the highway about 500 feet west of the dam. The highway bridge was built to accommodate discharge from the spillway. The spillway is a 60 foot long concrete ogee weir at elevation 570. The weir crest is 49.5 feet from the upstream side of the bridge. The chute under the bridge is 50 feet wide. The spillway discharge channel was excavated through rock for a distance of about 250 feet. Discharge from the channel then flows through a channel excavated to the top of rock for a

distance of about 350 feet before joining the original water course of Conestoga Creek.

The outlet works are located in the dam section and consist of an intake tower, as shown on Photograph 4, and two concrete encased conduits: a 20 inch water supply line and a 48 inch pond drain conduit. The 20 inch line goes to the pumphouse located about 275 feet downstream of the dam centerline. Water from Mill Water Pond Reservoir and the downstream Clear Water Pond Reservoir is pumped uphill to an ore processing plant. The upstream inverts of the 20 inch and 48 inch conduits are at elevation 550. Used rails form the trashrack. There are three anti-seep collars within the impervious core of the embankment, encompassing both conduits. A foot bridge provides access to the top of the intake tower from the dam breast.

b. Location. The dam is located across Back Creek, a tributary of Conestoga Creek, in Caernarvon Township, Berks County, Pennsylvania. The dam site is located approximately 0.87 mile northeast of the intersection of the Pennsylvania Turnpike and PA Highway Route 10, and one mile northeast of Morgantown, Pennsylvania. The dam site and reservoir are located on the USGS Quadrangle map entitled, "Morgantown, Pennsylvania", at coordinates N 40° 9.9' W 75° 52.6'. A regional location plan of Mill Water Pond Dam and reservoir is enclosed as Plate 1, Appendix E.

c. Size Classification. The dam is classified as a "Small" size structure by virtue of its 26 foot height and estimated total capacity of 210 acre-feet.

d. Hazard Classification. A "High" hazard classification is assigned consistent with the dam's location immediately above an occupied dwelling and above commercial buildings and other residences farther downstream on Conestoga Creek.

e. Ownership. Mill Water Pond Dam is owned by the Bethlehem Mines Corporation. All correspondence should be addressed to Mr. Carl Taylor, Bethlehem Mines Corporation, Martin Tower, 8th & Easton Avenues, Bethlehem, Pennsylvania 18016.

f. Purpose of Dam. The dam was originally built as an industrial water supply dam for the Grace Mine. As the mine is no longer in operation, water from the reservoir is no longer used.

g. Design and Construction History. In May 1954, application was made for permission to build a dam across Back Creek. On June 1, 1954, the state submitted the "Report Upon the Application" to build the dam. The design, prepared by

Bethlehem Cornwall Corporation's Mining Engineering department, was approved and a construction permit issued on June 9, 1954. Mill Water Pond Dam was constructed by Jack and Jim Maser of Brownstown, Pennsylvania, in conjunction with Clear Water Pond Dam, located about 600 feet east of Mill Water Pond and shown on Plate 1, Appendix E. Memoranda in the state files indicate that the dam was well constructed. Water started to flow over the spillway on December 21, 1954, and the dam was considered complete on January 17, 1955, when the operating platform and steel grating had been set in place and painted.

In 1964, application was made to construct a 45 foot high diversion dam intercepting runoff from the upper 1.3 square miles of the total 2.85 square mile watershed above Mill Water Pond Dam. Located between the two dams is the iron ore body. The iron was mined from the deep mine approximately 1,600 feet below the ground surface by the "block caving" method, creating a large subsidence area. The purpose of the upper mine was to prevent surface runoff from flowing into the subsidence area and subsequently seeping into the deep mine. The diversion dam, DER No. 6-458, was constructed in 1964 and 1965. A 16 inch siphon line supplied water from the diversion dam to Mill Water Pond when required. In 1971, a diversion ditch was designed and subsequently constructed (under permit) to divert additional watershed runoff over the watershed divide into Hay Creek. As a result of the surface subsidence resulting from mining, and huge piles of cobber reject downstream of the subsidence, the watershed area above Mill Water Pond has been reduced to 0.31 square mile.

h. Normal Operating Procedures. As the mill at Grace Mine has been shut down, water is no longer required for the process. Discharge normally flows over the ogee weir under PA Route 10 and down Conestoga Creek. The siphon line still discharges water from the diversion dam to Mill Water Pond at least part of the time.

1.3 Pertinent Data.

The summary of pertinent data for Mill Water Pond Dam is presented as follows.

- | | | |
|----|---------------------------------|---------|
| a. | Drainage Area (square miles) | 0.31 |
| b. | Discharge at Dam Site (cfs) | |
| | Maximum Known Flood at Dam Site | Unknown |
| | At Top of Dam | 2,600 |

c.	Elevation (feet above MSL)	
	Top of Dam	
	Existing	576.0
	Design	575.0
	Spillway Weir Crest	570.0
	Water Supply Intake	550.0
	Pond Drain Inlet	550.0
	Downstream Toe	554.3
	Spillway Chute Under Bridge	564.2±
d.	Reservoir Length (feet)	
	Length at Normal Pool	1,700
e.	Storage (acre-feet)	
	To Spillway Crest (normal pool)	133
	To Top of Dam (design)	210
f.	Reservoir Surface Area (acres)	
	Normal Pool	15.7
g.	Embankment Data	
	Type	Zoned earth
	Volume	30,400 cubic yards
	Length	440 feet
	Maximum Height (above original ground)	26 feet
	Top Width	20 feet
	Side Slopes	
	Upstream	3 H:1V
	Downstream	2.5H:1V
	Cutoff	Relatively impervious zone extends under upstream zone & overlies entire reservoir bottom
	Grout Curtain	None
h.	Spillway	
	Type	Ogee concrete weir
	Length	60 feet
	Weir Crest Elevation	570.0
i.	Outlet Works	
	Type	Concrete intake tower w/ 2 sluice gates
	Water Supply Intake Elevation	550.0
	Pond Drain	
	Type	48" corrugated metal pipe encased in concrete
	Inlet Elevation	550.0

SECTION 2 ENGINEERING DATA

2.1 Design.

a. Data Available. The data available for review are contained in the Pennsylvania Department of Environmental Resources (DER) files and consist of plans, photographs, correspondence, inspection reports and memoranda. No engineering analyses were located in DER files.

b. Design Features. The principal design features of Mill Water Pond Dam are illustrated on plans and cross-sections enclosed in Appendix E. Data for these sections were obtained from plans located in DER files. A description of the design features is also described in Section 1.2, paragraph a, and pertinent data relative to the structure are presented in Section 1.3.

2.2 Construction.

Beyond the memoranda in DER files, there are no data available concerning the construction history of this dam and reservoir.

2.3 Operational Data.

There are no operational records maintained. There are no minimum flow requirements downstream of this dam.

2.4 Evaluation.

a. Availability. Information presented herein was obtained from the records located in DER files in Harrisburg, Pennsylvania, and from conversations with the Owner's representative.

b. Adequacy. The available data included in the state files and supplemented by the visual inspection are considered adequate to evaluate the engineering aspects of the dam and appurtenant structures.

c. Validity. There is no reason to question the validity of the available data.

SECTION 3
VISUAL INSPECTION

3.1 Findings.

a. General. Observations and comments of the field inspection team are contained in the checklist enclosed herein as Appendix A, and are summarized and evaluated in the following subsections. In general, the appearance of the facility indicates that the dam is in good condition. Plan and cross-sections of the dam are presented in Appendix E.

b. Dam. During the visual inspection, there were no indications of distortions in alignment or grade that would be indicative of movement of the dam or the foundation. The vertical alignment of the dam was checked and spot elevations are shown on Plate 2, Appendix E. As shown in Photograph 9, heavy brush and briars are growing along the waterline of the embankment. Sumac is also growing along the waterline on the side of the reservoir next to the road, but is not considered detrimental as this is natural ground. The crest is protected with grass which is mowed, and the downstream slope is brush covered. There are two small trees starting to grow on the downstream slope. At the toe of the slope some evergreen trees are growing. The only seepage noted was at the junction of the dam embankment and the highway embankment, as shown on sheet 5a, Appendix A.

c. Appurtenant Structures.

1. Spillway. The concrete ogee weir appears to be in good condition with some cracking. Photograph 10 shows a surface irregularity of the crest of the weir. The same irregularity shows up in a photograph included in DER files. There are leachate deposits in horizontal cracks in the weir, indicating seepage through the weir. Some erosion of the concrete has taken place where the bottom of the weir meets the channel pavement. No significant deterioration or movement of the pavement or the channel sidewalls was noted. The PA Route 10 bridge crossing the spillway chute was also inspected. As shown on Photograph 13, rotation and separation has occurred at each wing wall and bridge junction. Photograph 12 shows a crack extending the full height of the right retaining wall under the bridge. The crack is wider at the top.

2. Outlet Works. The intake structure appears to be in good condition. The hoist for the 20 inch sluice gate operated easily. A handle was not available to operate the 48 inch pond drain gate. The stems on both gates appear dry and

in need of lubrication. The 20 inch steel water supply pipe is completely underground and goes directly to the downstream pumphouse. The outlet of the pond drain is not constructed, as shown on Plate 2. The pond drain conduit apparently flows into a concrete box culvert, which bends to the right and exits into a downstream channel. The outlet of the box culvert is apparently 48 inches wide by 40 inches high and is silted in to a depth of 26 inches. The channel immediately downstream of the outlet is also silted in. About 15 feet below the outlet, the silted channel converges with a paved storm drain channel, which is not silted. Discharge from the pond drain then would pass under Route 10, as shown on Photograph 6.

d. Reservoir. The reservoir sides slopes are moderate and well vegetated with grass adjacent to the reservoir. Farther up the watershed, the ground is disturbed as a result of mining. See Section 5 for a complete description of the watershed. There is a large amount of sediment at the upper end of the reservoir; however, this sediment has little or no effect on flood water storage.

e. Downstream Channel. Immediately below the dam, the paved pond drain channel passes under Route 10, Photograph 6, and joins with the discharge from Clear Water Pond, also owned by Bethlehem Mines and located on the opposite side of Route 10 from Mill Water Pond. As shown on Plate 1, Conestoga Creek first flows west, then south.

Spillway discharge flows through the excavated channel before joining Conestoga Creek about 600 feet downstream of the spillway weir. About 500 feet below the confluence of the spillway discharge with Conestoga Creek, Conestoga Creek flows through a light industrial area, adjacent to the Morgantown Trailer Works. About 2,000 feet below the spillway, Conestoga Creek passes under a highway and adjacent to some homes.

In the event of failure of the dam itself, the pumphouse about 275 feet downstream of the dam would be damaged and an occupied home 400 feet below the dam would be damaged, with the potential for loss of life. Thus, in the event of failure, excessive property damage is likely and possible loss of life, justifying a "High" hazard potential classification.

3.2 Evaluation.

In summary, the visual survey of the dam and appurtenant facilities disclosed no evidence of incipient failure of the dam. The only items noted are of a routine maintenance nature, including cutting of the brush on the upstream and downstream slopes of the embankment, and monitoring, at least visually, the seepage area noted at the right abutment of the dam. The Route 10 highway bridge, while not part of the dam itself, should be inspected by the Pennsylvania Department of Transportation (PennDOT) engineers to assess the need for repairs.

SECTION 4
OPERATIONAL PROCEDURES

4.1 Procedures.

Operation of the dam does not require a dam tender. Under present conditions, with the mill closed, the water supply gate is closed. Water normally discharges over the spillway at elevation 570.

4.2 Maintenance of the Dam.

There are no written maintenance procedures for the dam. In actual practice, Bethlehem Mines' engineering department occasionally inspects the dam.

4.3 Maintenance of Operating Facilities.

There are no written procedures for maintenance of the operating facilities.

4.4 Warning Systems In Effect.

There are no written warning procedures in effect for this dam. In the event of failure, property owned by Bethlehem Mines Corporation would be subject to damage, including an occupied residence about 400 feet downstream of the dam.

4.5 Evaluation.

It is judged that the current operating procedure, which does not require a dam tender, is a realistic means of operating the relatively simple control facilities of Mill-water Pond Dam. In conclusion, it is noted that formal operational, maintenance and warning procedures should be developed and implemented. These procedures should include an inspection checklist, which would consist of a list of items that should be checked during each inspection and repaired as necessary to insure proper performance of the structure.

SECTION 5
HYDROLOGY/HYDRAULICS

5.1 Evaluation of Features.

a. Design Data. The original design of this dam was considered to be satisfactory by the Commonwealth of Pennsylvania.

The watershed has changed considerably since this dam was designed and built. The original watershed area was 2.85 square miles. In 1964-1965, a diversion dam was designed and built, intercepting runoff from the upper 1.3 square miles of the watershed. The purpose of the diversion dam was to prevent water from entering the deep mine located between the diversion dam and Mill Water Pond. Mining of this deep ore body was by the block caving method, causing considerable subsidence above the ore body. As shown on Plate 1A, cobber reject was disposed of downstream of the subsidence area. In 1971, a diversion ditch was designed and subsequently constructed, which intercepted some runoff from the northeastern portion of the watershed and carried seepage and some runoff from below the diversion dam over the watershed divide into the Hay Creek Watershed to the north. Therefore, currently, Mill Water Pond intercepts surface runoff only from about 0.31 square mile immediately above the dam. In the event of failure of the diversion dam, water from the diversion dam would enter and be retained within the subsidence area and would not flow into Mill Water Pond. Thus, the existing watershed is now about 0.3 mile wide and about 0.7 mile long, with elevations ranging from 800 feet in the upper reaches to about 570 at normal pool elevation.

In accordance with criteria established by Federal (OCE) Guidelines, the spillway design flood for this "Small" size dam and "High" hazard classification is one-half to the full Probable Maximum Flood. As the dam height and total capacity are near the lower limit of the size classification, the selected spillway design flood is one-half the PMF.

b. Experience Data. Weekly records of reservoir levels are maintained, but no rainfall records are kept within the watershed. There were no estimates or records of previous high water levels available.

c. Visual Observations. On the date of the inspection, there were no conditions observed that might indicate a possible reduction in spillway capacity during an extreme event. Other observations regarding the condition of the

downstream channel, spillway and reservoir are presented in Appendix A and are discussed in greater detail in Section 3.

d. Overtopping Potential. The overtopping potential of this dam was estimated using the HEC-1, Dam Safety Version, computer program. A brief description of this program is included in Appendix D.

Calculations (see Appendix D) for this investigation estimate the maximum spillway capacity to be about 2,600 cfs, which is greater than the full PMF peak inflow of 1,248 computed by the computer program for the existing watershed. The capacity of the siphon is not considered significant during an extreme event. The 0.5 PMF peak inflow for the original watershed, before the diversion dam was built, is estimated to be about 2,030 cfs. As the spillway capacity is greater than the peak one-half PMF inflow for the present watershed, no reservoir routing was necessary.

e. Spillway Adequacy. As the spillway can pass the spillway design storm without overtopping the embankment, the spillway is considered "Adequate".

f. Downstream Conditions. The downstream hazard center with the possibility for loss of life is about 400 feet downstream of the dam. A house owned by Bethlehem Mines Corporation is occupied. In the event of sudden failure of the dam, the limited size (about 16 feet wide by 7 feet high) culvert under Route 10 would back up water to where the house and the pump station are located. The flood wave would be attenuated sharply by the culvert under Route 10 and a downstream culvert under an unnamed road. The Morgantown Trailer Works would be expected to suffer property damage, but loss of life is not envisioned.

SECTION 6
STRUCTURAL STABILITY

6.1 Evaluation of Structural Stability.

a. Visual Observations. Visual observations detected no evidence of existing or impending embankment instability. Upstream and downstream slopes appear to be stable and in good condition.

Exposed portions of the concrete weir, channel floor and walls were inspected and judged to be in good condition. The highway bridge over the spillway channel was also inspected. Movement was noted of all four wing walls and cracks were noted on both abutment walls of the bridge. This bridge should be inspected by PennDOT to assess the need for repairs.

b. Design and Construction Data. Design and construction data were limited to the design drawings and memoranda in the state files indicating that the dam was well constructed. Based on that data and the visual inspection, it is qualitatively assessed that the stability of the dam is adequate.

c. Operating Records. There are no operational records for this structure.

d. Post-Construction Changes. There are no reports nor is there any evidence that any major modifications were made to this dam. The only deviation noted from the design drawings is the outlet of the pond drain conduit, as noted in Section 3.1, subsection c, paragraph 2.

e. Seismic Stability. The dam is located in Seismic Zone 1. Normally it is considered that if a dam in this zone is stable under static loading conditions, it can be assumed safe for any expected earthquake conditions. As the dam is qualitatively assessed to be stable under static loading conditions, it can reasonably be assumed to be stable under seismic loading conditions.

SECTION 7
ASSESSMENT/REMEDIAL MEASURES

7.1 Dam Assessment.

a. Evaluation. Visual inspection indicates that the dam, foundation and spillway structures of Mill Water Pond Dam are in good condition.

In accordance with criteria established by Federal (OCE) Guidelines, the spillway design flood for this "Small" size dam and "High" hazard classification is one-half to the full Probable Maximum Flood. As the dam height and total capacity are near the lower limit of the size classification, the selected spillway design flood is one-half the PMF. Hydrologic and hydraulic computations presented in Appendix D indicate the maximum spillway capacity is greater than the peak PMF inflow from the reduced size watershed. Therefore, the spillway system of this "High" hazard classification structure is considered to be "Adequate".

b. Adequacy of Information. The combined visual inspection, obvious performance history of the structure, and simplified calculations presented in Appendix D were sufficiently adequate to determine that no further investigations are required for this structure.

c. Urgency. It is recommended that the measures presented in Section 7.2 be implemented as specified.

7.2 Remedial Measures.

a. Facilities. It is recommended that the following measures be undertaken as soon as practical.

1. The brush on the upstream and downstream slopes of the embankment should be cut on an annual basis. The two small pine trees noted on the downstream embankment should be removed and the embankment restored to its original condition.
2. The seepage noted downstream of the embankment should be monitored at least visually on a regular basis. Any significant increase in seepage amount or development of turbidity should be evaluated by a registered professional engineer experienced in the design and construction of dams.

The following measure should be undertaken immediately.

3. The highway bridge over the spillway channel should be inspected by a PennDOT engineer to assess the need for repairs.

- b. Operation and Maintenance Procedures. Because of the location of the dam above an occupied residence, with the potential for loss of life in the event of failure and excessive property damage farther downstream along Conestoga Creek, a formal procedure of observation and warning during periods of high precipitation should be developed and implemented. This procedure should include a method of warning downstream residents and industries if high flows are expected and provisions for evacuating these people in the event of an emergency. In addition, an operation and maintenance procedure should also be developed to insure that all pertinent items are carefully inspected on a regular basis and maintained in the best possible condition.

APPENDIX

A

CHECK LIST
VISUAL INSPECTION
PHASE I

Sheet 1 of 11

Name Dam Mill Water Pond Dam County Berks State Pennsylvania National ID # PA 00703
Type of Dam Earth Hazard Category High
Date(s) Inspection 11/15/79 Weather Cloudy Temperature 50's

Pool Elevation at Time of Inspection 570± M.S.L. Tailwater at Time of Inspection N/A M.S.L.

Inspection Personnel:

Mary F. Beck (Hydrologist) Vincent McKeever (Hydrologist)
Arthur H. Drinoff (Geotechnical)
Raymond S. Lambert (Geologist)

Mary F. Beck Recorder

Remarks:

Mr. Carl Taylor, Jr. and Mr. Fred Eben of Bethlehem Mines Corporation were on site and provided assistance to the inspection team.

CONCRETE/MASONRY DAMS

Sheet 2 of 11

VISUAL EXAMINATION OF OBSERVATIONS REMARKS OR RECOMMENDATIONS

ANY NOTICEABLE SEEPAGE

N/A

STRUCTURE TO
ABUTMENT/EMBANKMENT
JUNCTIONS

N/A

DRAINS

N/A

WATER PASSAGES

N/A

FOUNDATION

N/A

CONCRETE/MASONRY DAMS

Sheet 3 of 11

VISUAL EXAMINATION OF	OBSERVATIONS	REMARKS OR RECOMMENDATIONS
SURFACE CRACKS CONCRETE SURFACES	N/A	
STRUCTURAL CRACKING	N/A	
VERTICAL AND HORIZONTAL ALIGNMENT	N/A	
MORLITH JOINTS	N/A	
CONSTRUCTION JOINTS	N/A	

EMBANKMENT

Sheet 4 of 11

VISUAL EXAMINATION OF OBSERVATIONS REMARKS OR RECOMMENDATIONS

SURFACE CRACKS

None observed.

UNUSUAL MOVEMENT OR
CRACKING AT OR BEYOND
THE TOE

None observed.

SLOUGHING OR EROSION OF
EMBANKMENT AND ABUTMENT
SLOPES

None observed.

VERTICAL AND HORIZONTAL
ALIGNMENT OF THE CREST

No apparent vertical or horizontal movements were observed. Spot elevations determined are shown on Plate 2, Appendix E, and the profile is shown on Sheet 5B of this Appendix.

RIPRAP FAILURES

None observed.

EMBANKMENT

Sheet 5 of 11

VISUAL EXAMINATION OF OBSERVATIONS REMARKS OR RECOMMENDATIONS

JUNCTION OF EMBANKMENT
AND ABUTMENT, SPILLWAY
AND DAM

Junctions appear in good condition with the exception of seepage noted below.

ANY NOTICEABLE SEEPAGE

Seepage occurs at the junction of the right end of the dam and the highway embankment. Marshy area extends to the downstream channel, see Sheet 5a.

STAFF GAGE AND RECORDER

None

DRAINS

None

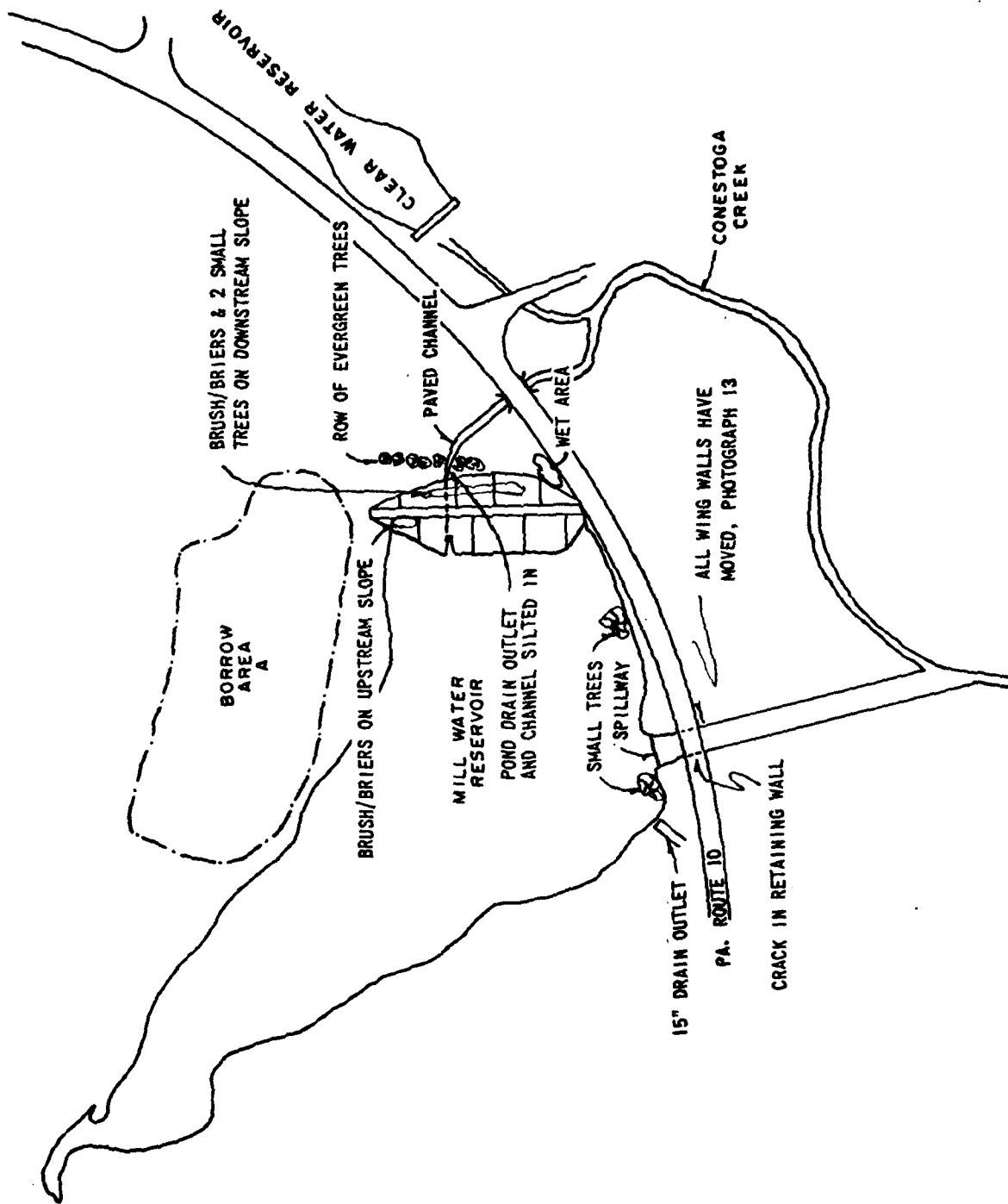

FIELD OBSERVATION PLAN
 MILL WATER DAM
 SHEET 5A OF 11

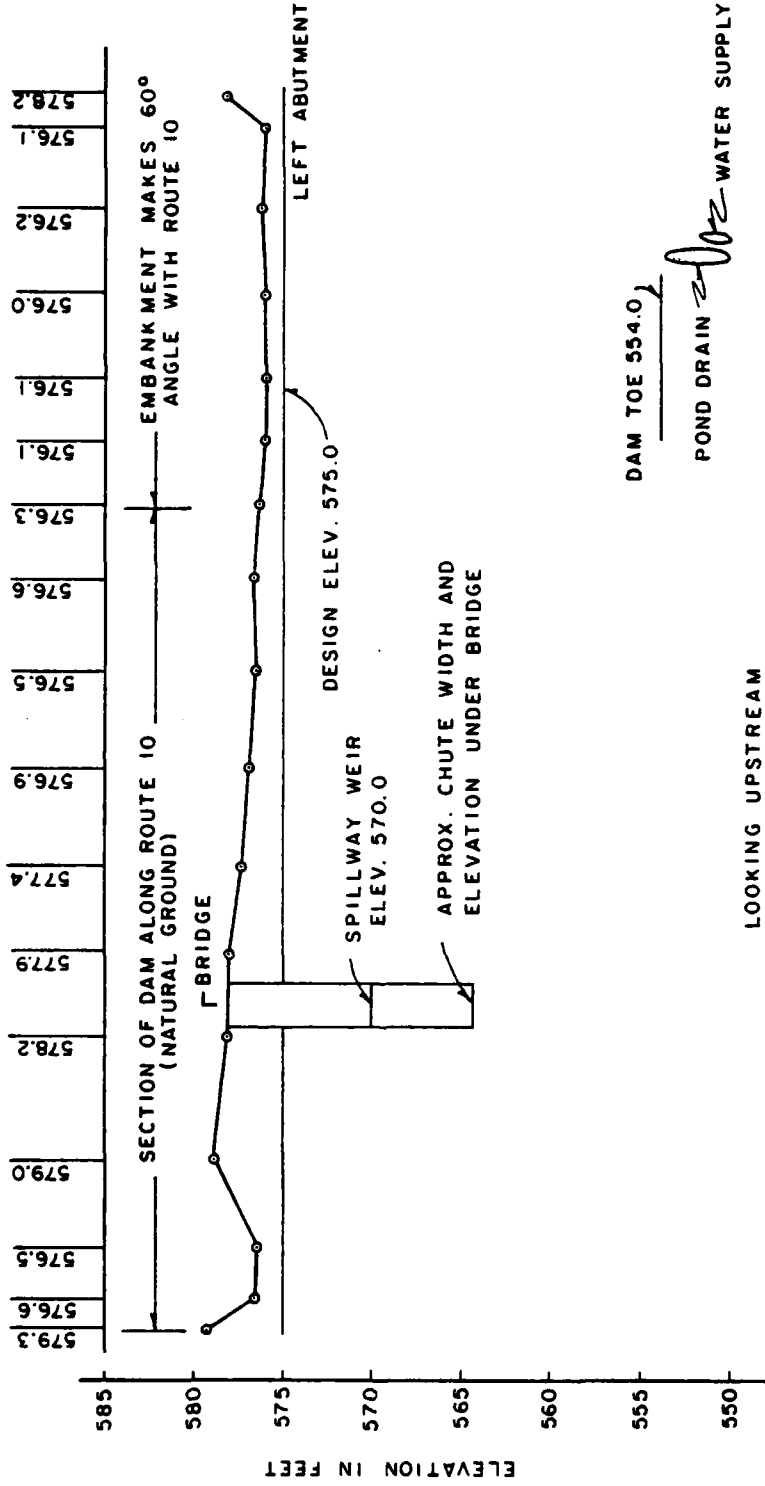

OUTLET WORKS

Sheet 6 of 11

VISUAL EXAMINATION OF	OBSERVATIONS	REMARKS OR RECOMMENDATIONS
CRACKING AND SPALLING OF CONCRETE SURFACES IN OUTLET CONDUIT	<p>Conduits under embankment, not inspected.</p>	
INTAKE STRUCTURE	<p>Structure appears in good condition. A 20-inch steel pipe goes to downstream pump house. A 48-inch CMP is the pond drain.</p>	
OUTLET STRUCTURE	<p>The pond drain exits to a downstream channel. The outlet is apparently 48 inches wide by 40 inches high and is partially silted, 26 inches deep. See Photograph No. 5.</p>	
OUTLET CHANNEL	<p>The channel immediately downstream of the outlet is silted. About 15 feet below the outlet, the silted channel converges with a paved storm drain channel which was not silted.</p>	
EMERGENCY GATE	<p>Handle not available to operate the 48-inch pond drain gate. The hoist for the 20-inch sluice gate operated easily.</p>	

UNGATED SPILLWAY

Sheet 7 of 11

VISUAL EXAMINATION OF OBSERVATIONS REMARKS OR RECOMMENDATIONS

CONCRETE WEIR

The concrete ogee weir appears in good condition with some cracking. Leachate deposits at horizontal cracks in weir indicate seepage through weir. Some erosion of the concrete has taken place where the bottom of the weir meets the channel pavement.

APPROACH CHANNEL

None.

DISCHARGE CHANNEL

There has been some settlement of chute wall backfill at construction joints.

BRIDGE AND PIERS

The right bridge abutments show up to three inches of movement and a crack, estimated to be an inch wide at the top, extends from the top to the bottom of the wall near the downstream end. See Photograph No. 12.

GATED SPILLWAY

Sheet 8 of 11

<u>VISUAL EXAMINATION OF</u>	<u>OBSERVATIONS</u>	<u>REMARKS OR RECOMMENDATIONS</u>
CONCRETE SILL	N/A	
APPROACH CHANNEL	N/A	
DISCHARGE CHANNEL	N/A	
BRIDGE AND PIERS	N/A	
GATES AND OPERATION EQUIPMENT	N/A	

INSTRUMENTATION

Sheet 9 of 11

VISUAL EXAMINATION OBSERVATIONS REMARKS OR RECOMMENDATIONS

MONUMENTATION/SURVEYS

None

OBSERVATION WELLS

None

WEIRS

None

PIEZOMETERS

None

OTHER

None

RESERVOIR

Sheet 10 of 11

REMARKS OR RECOMMENDATIONS

OBSERVATIONS

VISUAL EXAMINATION OF

SLOPES

The reservoir slopes are moderate and well vegetated with grass adjacent to the reservoir. Further up the watershed, the ground is disturbed as a result of mining. The reservoir was constructed with an impervious lining. The impervious material extends under the upstream slope to the impervious core.

SEDIMENTATION

A large amount of sediment is at the upper end. Sediment has little or no effect on flood water storage.

DOWNSTREAM CHANNEL

Sheet 11 of 11

REMARKS OR RECOMMENDATIONS

OBSERVATIONS

VISUAL EXAMINATION OF

CONDITION
(OBSTRUCTIONS,
DEBRIS, ETC.)

The downstream channel is in good condition.

SLOPES

The valley gradient is approximately 0.027 for about 800 feet below the dam. The valley gradient flattens to about 0.004, thereafter.

APPROXIMATE NO.
OF HOMES AND
POPULATION

One home is located about 400 feet downstream of the dam. About 1500 feet below the spillway is Morgan Trailer Manufacturing Company.

APPENDIX

B

NAME OF DAM Mill Water Pond Dam
ID # PA 00703

CHECK LIST
ENGINEERING DATA
DESIGN, CONSTRUCTION, OPERATION
PHASE I

Sheet 1 of 4

REMARKS

ITEM

AS-BUILT DRAWINGS

Not available.

REGIONAL VICINITY MAP

Plate 1, Appendix E.

CONSTRUCTION HISTORY

See text.

TYPICAL SECTIONS OF DAM

See Appendix E.

OUTLETS - PLAN

DETAILS

CONSTRAINTS

DISCHARGE RATINGS

RAINFALL/RESERVOIR RECORDS

See Appendix E.

See Appendix D.

None available.

ITEM REMARKS

DESIGN REPORTS
None available.

GEOLOGY REPORTS
See Appendix F.

DESIGN COMPUTATIONS
HYDROLOGY & HYDRAULICS
DAM STABILITY
SEEPAGE STUDIES
Not available.

MATERIALS INVESTIGATIONS
BORING RECORDS
LABORATORY
FIELD
Not available.

POST-CONSTRUCTION SURVEYS OF DAM
See Plate 2, Appendix E.

BORROW SOURCES
The area north of the reservoir.

ITEM	REMARKS
MONITORING SYSTEMS	<i>None</i>
MODIFICATIONS	<i>None known.</i>
HIGH POOL RECORDS	<i>None available.</i>
POST CONSTRUCTION ENGINEERING STUDIES AND REPORTS	<i>None known.</i>
PRIOR ACCIDENTS OR FAILURE OF DAM DESCRIPTION REPORTS	<i>None</i>
MAINTENANCE OPERATION RECORDS	<i>None</i>

ITEM	REMARKS
SPILLWAY PLAN	See Appendix E.
SECTIONS DETAILS	
OPERATING EQUIPMENT PLANS & DETAILS	See Appendix E.
MISCELLANEOUS	<ol style="list-style-type: none">1. Inspection reports and memos prepared by the State.2. Correspondence located in DER files.3. Design drawings in DER files.4. Watershed maps, diversion ditch drawings supplied by the Owner.5. Black and white photographs in DER files.

APPENDIX

C

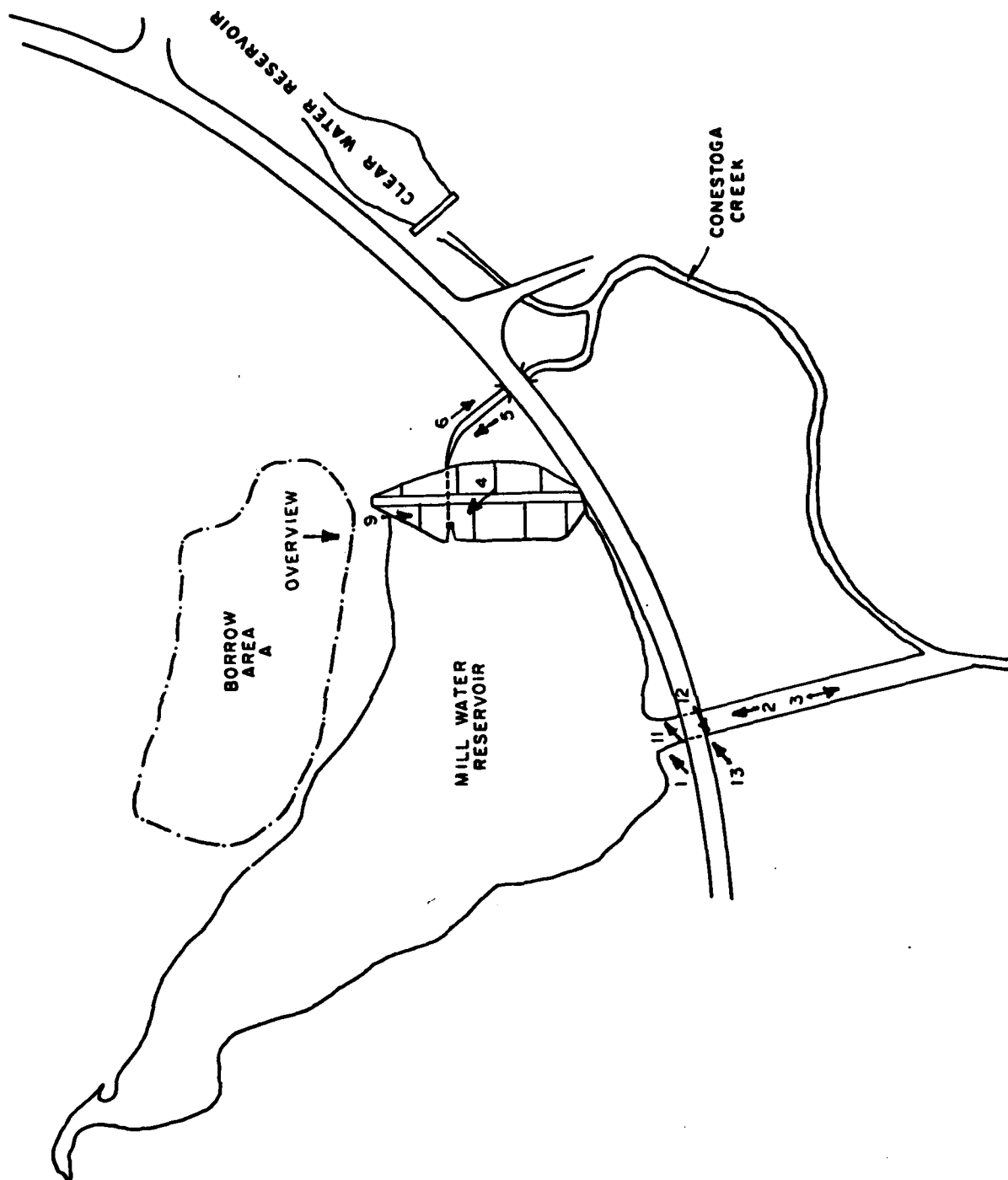

PHOTOGRAPH LOCATION PLAN
MILL WATER POND

PLATE C-1



OGEE SPILLWAY. SOME SETTLEMENT HAS
OCCURRED BEHIND THE CHUTE WALL JOINT
(AT LOCATION OF FIELD BOOK)

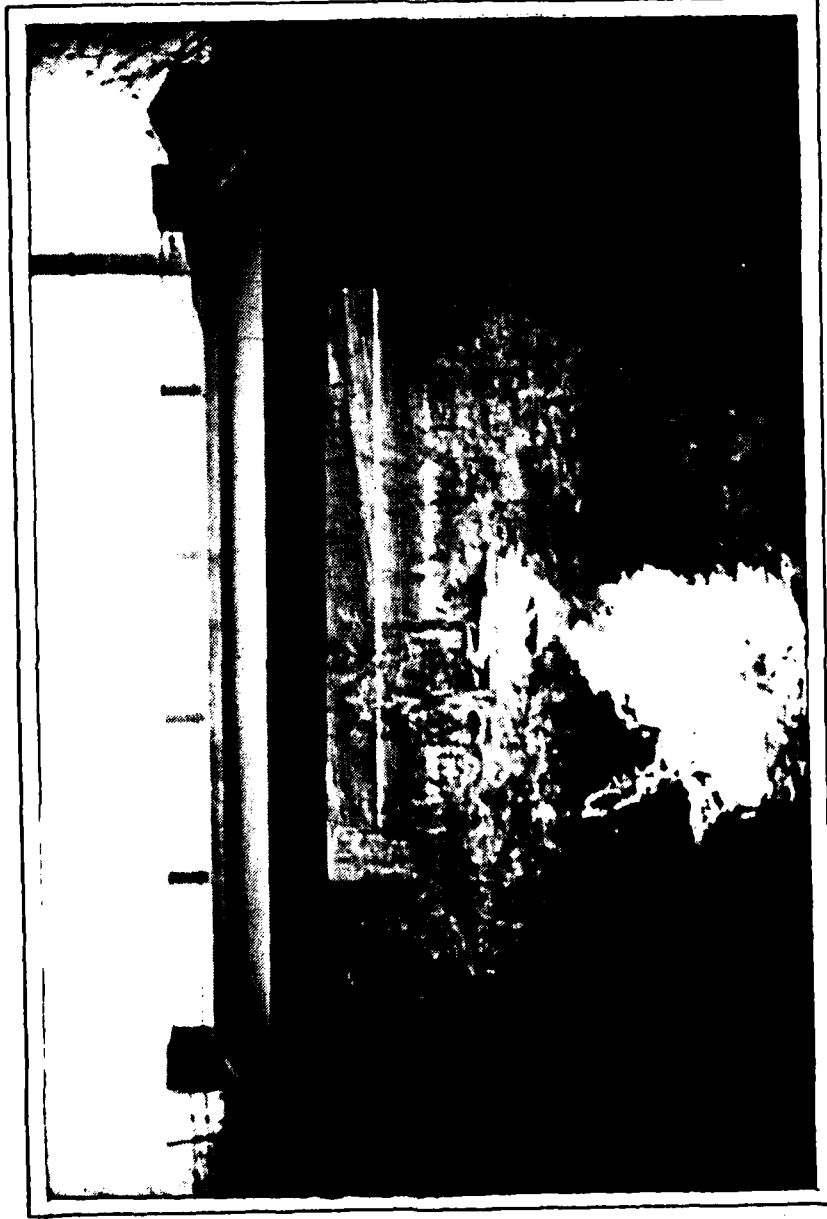

VIEW OF SPILLWAY UNDER PA ROUTE
10 BRIDGE.

PHOTOGRAPH NO. 2



DOWNSTREAM CHANNEL BELOW BRIDGE.

PHOTOGRAPH NO. 3

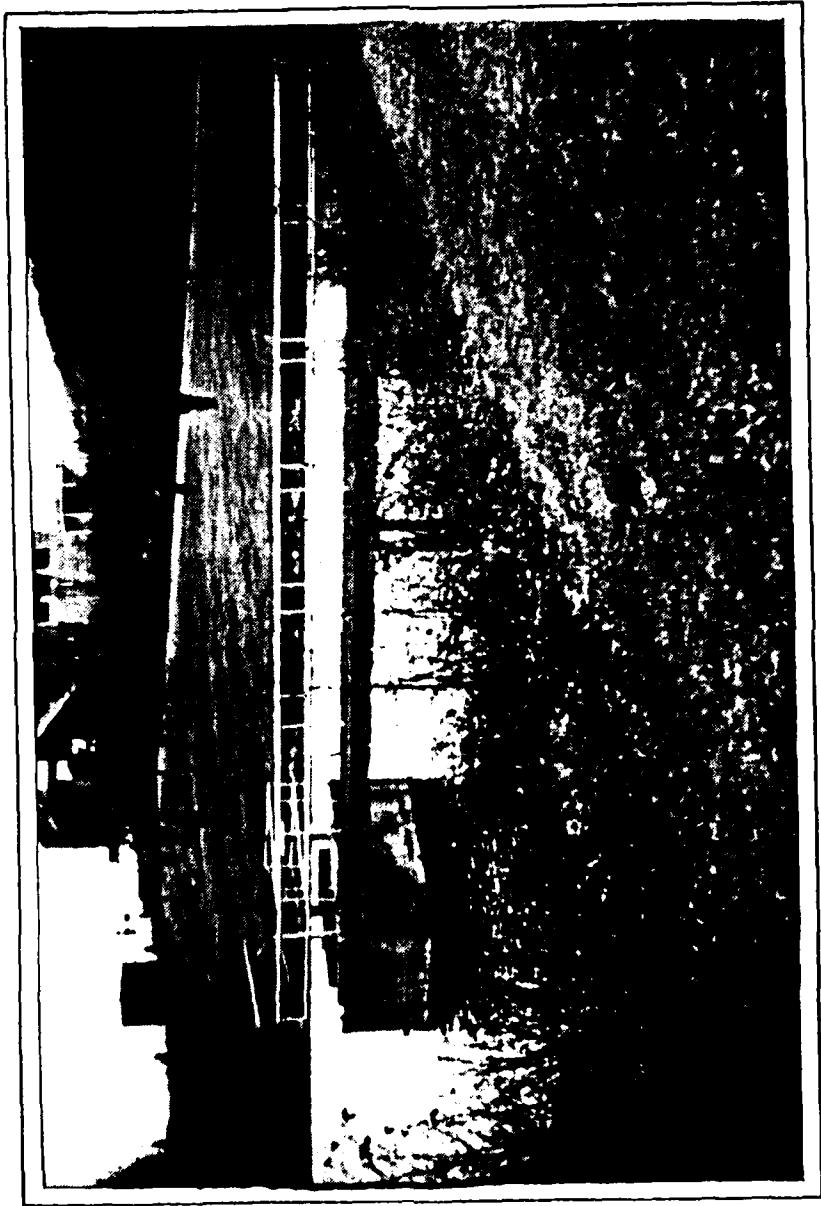

INTAKE STRUCTURE AND ACCESS BRIDGE.

PHOTOGRAPH NO. 4



POND DRAIN OUTLET, THE RECTANGULAR
CONDUIT IS SILTED IN FOR A DEPTH OF
26 INCHES.

PHOTOGRAPH NO. 5



DISCHARGE FROM POND DRAIN WOULD PASS
THROUGH CULVERT UNDER PA ROUTE 10.

PHOTOGRAPH NO. 6

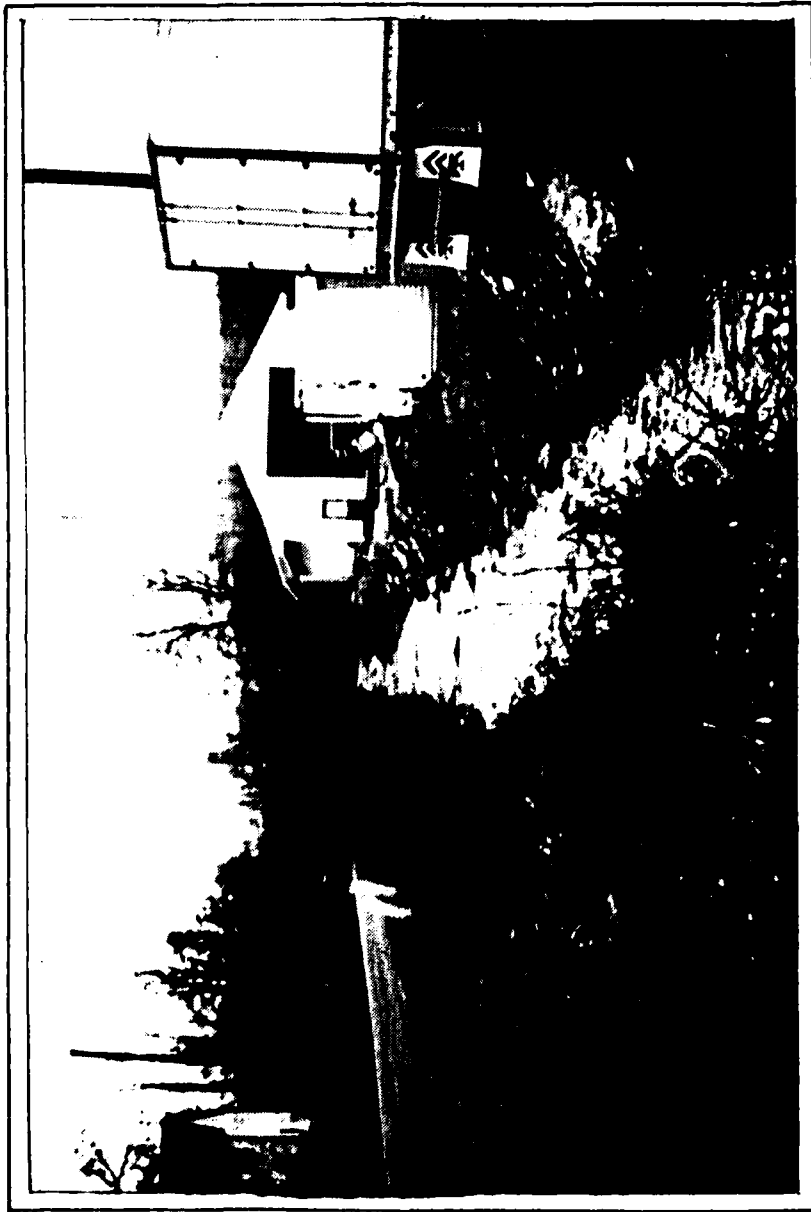

DOWNSTREAM HAZARD CENTER, MORGANTOWN
TRAILER MANUFACTURER.

PHOTOGRAPH NO. 7

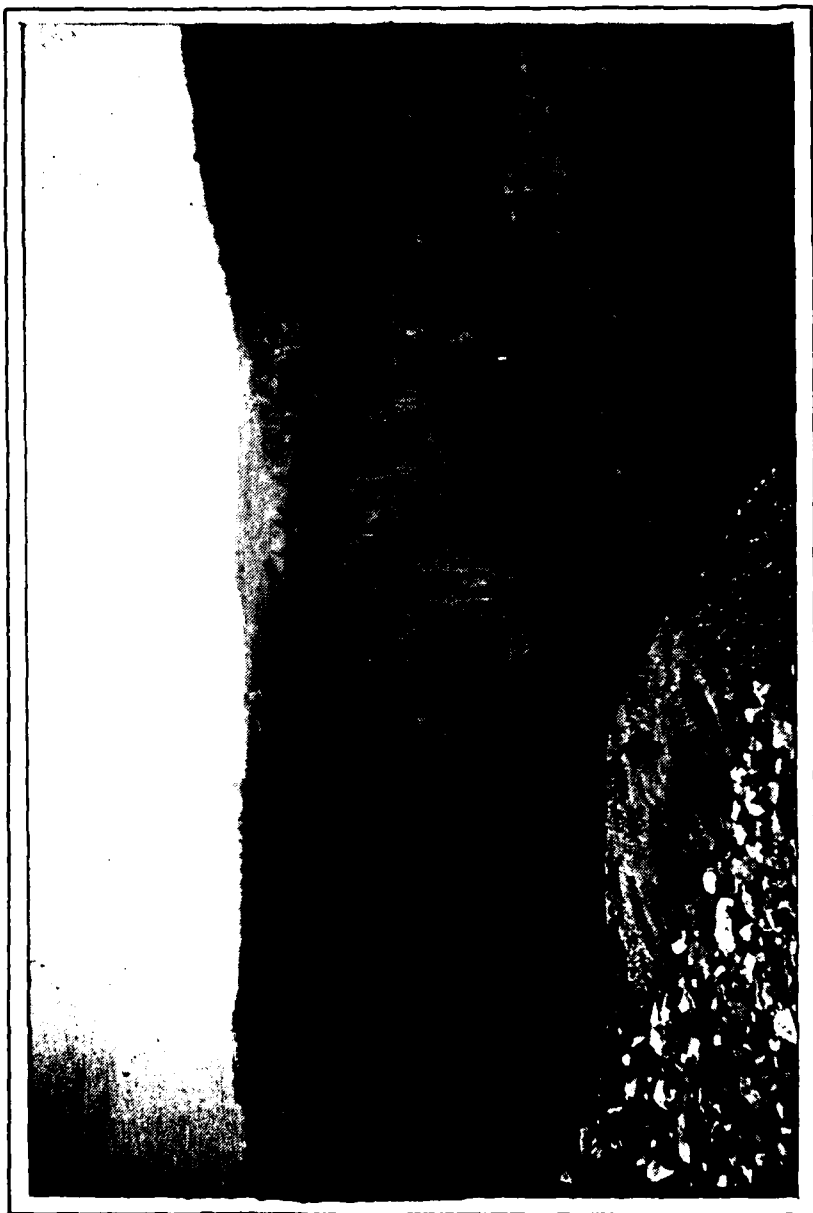

WATERSHED AREA ABOVE THE DAM HAS BEEN
REDUCED AS A RESULT OF SUBSIDENCE
RESULTING FROM THE DEEP IRON ORE MINE.

PHOTOGRAPH NO. 8



BRUSH ALONG WATERLINE ON EMBANKMENT.

PHOTOGRAPH NO. 9

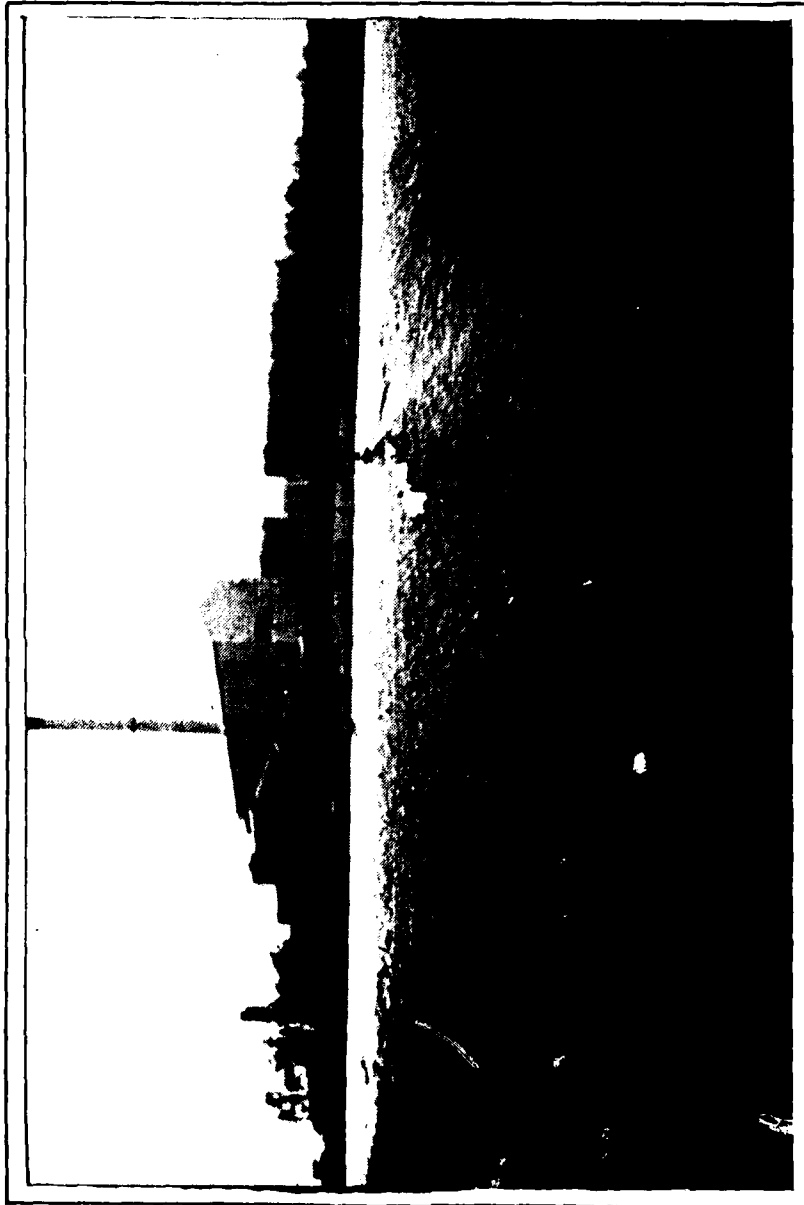

OGEE CREST, CONCRETE SURFACE HAS
BUCKLED AT LOCATION OF THE WHITE
WATER.

PHOTOGRAPH NO. 10



CRACKS AND SURFACE IRREGULATIES AT
BASE OF OGEE WEIR.

PHOTOGRAPH NO. 11



CRACK IN RIGHT BRIDGE ABUTMENT.
THE CRACK IS ABOUT ONE INCH WIDE
AND SIX INCHES DEEP AT THE TOP.

PHOTOGRAPH NO. 12



MOVEMENT OF BRIDGE WINGWALL. ALL
FOUR WINGWALLS HAVE MOVED.

PHOTOGRAPH NO. 13

APPENDIX

D

MILL WATER DAM
CHECK LIST
HYDROLOGIC AND HYDRAULIC
ENGINEERING DATA

DRAINAGE AREA CHARACTERISTICS: About 2/3 open land and 1/3 industrial.

ELEVATION TOP NORMAL POOL (STORAGE CAPACITY): 570.0 feet (133 Acre-Feet).

ELEVATION TOP FLOOD CONTROL POOL (STORAGE CAPACITY): 575.0 feet (210 Acre-Feet).

ELEVATION MAXIMUM DESIGN POOL: 575.0 feet.

ELEVATION TOP DAM: 575.0 feet design, 576.0 feet existing.

SPILLWAY

a. Elevation 570.0 feet

b. Type Concrete ogee wier, channel

c. Width 60 feet.

d. Length About 92 feet.

e. Location Spillover 500 feet west of dam, see Plate 1, Appendix E.

f. Number and Type of Gates None

OUTLET WORKS:

a. Type Concrete intake tower.

b. Location Maximum section of dam.

c. Entrance inverts 550 feet.

d. Exit inverts N/A, line goes directly to pump house.

e. Emergency draindown facilities 48 inch pond drain, entrance
invert at 550 feet.

HYDROMETEOROLOGICAL GAGES:

a. Type None

b. Location N/A

c. Records N/A

MAXIMUM NON-DAMAGING DISCHARGE: Not determined

MILL WATER DAM
HYDROLOGIC AND HYDRAULIC
BASE DATA

Sheet 2 of 7

DRAINAGE AREA: (1) 0.31 square miles.

PROBABLE MAXIMUM PRECIPITATION (PMP)
FOR 200 SQ. MILES IN 24 HOURS: (2) 22.2 inches.

ADJUSTMENT FACTORS FOR DRAINAGE AREA (%): (3)

Zone	<u>N/A</u>
6 Hours	<u>117%</u>
12 Hours	<u>127%</u>
24 Hours	<u>136%</u>
48 Hours	<u>143%</u>

SNYDER HYDROGRAPH PARAMETERS: (4)

Zone	<u>15C</u>
C_p, C_t	<u>0.82, 2.78</u>
L (5)	<u>0.66 mile</u>
Lca (6)	<u>0.43 mile</u>
$tp = C_t (L \cdot Lca)^{0.3}$	<u>1.90</u>

SPILLWAY CAPACITY AT MAXIMUM
WATER LEVEL (7) 2,600 cfs.

-
- (1) Measured from USGS maps.
 - (2) Hydrometeorological Report No. 40, Figure 2.
 - (3) Hydrometeorological Report No. 40.
 - (4) Information received from Corps of Engineers, Baltimore District.
 - (5) Length of longest water course from outlet to basin divide, measured from USGS maps.
 - (6) Length of water course from outlet to point opposite the centroid of drainage area, (see Plate I, Appendix E) measured from USGS maps.
 - (7) See Sheet 4 of this Appendix.

HEC-1, REVISED
FLOOD HYDROGRAPH PACKAGE

The original "Flood Hydrograph Package" (HEC-1), developed by the Hydrologic Engineering Center, Corps of Engineers, has been modified for use under the National Dam Inspection Program. The "Flood Hydrograph Package (HEC-1), Dam Safety Version", hereinafter referred to as, HEC-1, Rev., has been modified to require less detailed input and to include a dam breach analysis. The required input is obtained from the field inspection of a dam, any available design/evaluation data, relatively simple hydraulic calculations, or information from the USGS Quadrangle maps. The input format is flexible in order to reflect any unique characteristics of an individual dam.

HEC-1, Rev. computes a reservoir inflow hydrograph based on individual watershed characteristics such as: area, percentage of impervious surface area, watershed shape, and hydrograph characteristics determined from regional correlation studies by the Corps of Engineers, Baltimore District. The inflow is routed through the reservoir using spillway discharge data obtained from the field inspection or design data. Flood storage capacity is determined from USGS maps or design information and verified by the field inspection. In the event a spillway cannot discharge 0.5 PMF without overtopping and failure of the dam, downstream channel characteristics obtained from the field inspection and USGS maps are inputted and flows are routed downstream to the damage center and a dam breach analysis is performed.

Included in this Appendix are the HEC-1, Rev. pertinent input values and a summary print-out tables.

Classification (Ref. - Recommended Guidelines for Safety Inspection of Dams)

1. The hazard classification is rated as "High" as there would be economic loss and the potential for loss of life in the event of failure.
2. The size classification is "Small" based on its 26 ft. height and 210 Ac-Ft total storage capacity.
3. The selected spillway design flood, based on size and hazard classification is 0.5 PMF (Probable Maximum Flood).

Hydrology and Hydraulic Analysis

1. Original Data. The design drawings were available. The spillway capacity was estimated to be 2550 cfs.
2. Evaluation Data
Inflow hydrograph parameters are shown on sheet 2.

Elevation - Discharge Data. Maximum spillway capacity was determined from the ogee weir shape and "Design of Small Dam" U.S.B.R. as a reference. From the shape of the weir, the design head, H_o , was determined to be 5 ft. The height of the weir, P , is 5 ft. For $P/H_o = 1$, $C_o = 3.88$.

$$\begin{aligned} Q &= L C_o H_o^{3/2} \\ &= 60 \cdot 3.88 \cdot 5^{3/2} \\ &= 2,603 \text{ cfs.} \end{aligned}$$

3. Spillway Adequacy. The peak PMF inflow is 1248 cfs. As $Q > 1248$ cfs, the spillway is considered "Adequate"

1*****
FLOOD HYDROGRAPH PACKAGE (HEC-1)
DAM SAFETY VERSION JULY 1978
LAST MODIFICATION 26 FEB 79

RUN DATE* 80/02/27.
TIME* 05.36.44.

MILL WATER POND DAM
NDI NO. PA 00703 DER NO. 6-442
OVERTOPPING ANALYSIS

NO	MHR	MMIN	IDAY	JOB SPECIFICATION				IPRT	NSTAN
				IHR	IMIN	METRC	IPLT		
200	0	15	0	0	0	0	0	-4	0
			JOPER	NWT	LROPT	TRACE			
			5	0	0	0			

MULTI-PLAN ANALYSES TO BE PERFORMED
NPLAN= 1 NRTIO= 4 LRTIO= 1
RTIO9= .40 .90 1.00

SUB-AREA RUNOFF COMPUTATION

INFLOW HYDROGRAPH

ISTAG ICOMP IECON ITAPE JPLT JPRT INAME ISTAGE IAUTO
 IN 0 0 0 0 0 0 0 0 0 0

HYDROGRAPH DATA
 IHYDG IUNG TAREA SNAP TRSDA TRSPC RATIO ISNOW ISAME LOCAL
 1 .31 0.00 .31 1.00 0.000 0 1 0

PRECIP DATA
 SPFE PMS R6 R12 R24 R48 R72 R96
 0.00 22.20 117.00 127.00 136.00 143.00 145.00 0.00

LOSS DATA
 LROPT STRKR DLTKR RTIOL ERAIN STRKS RTIOK STRTL CNSYL ALSMX RTIMP
 0 0.00 0.00 1.00 0.00 0.00 1.00 1.00 1.00 .05 0.00 0.00

UNIT HYDROGRAPH DATA
 TP= 1.90 CP= .82 NTA= 0

RECESSION DATA
 STRIQ= -1.50 QRCSN= -.05 RTIOR= 2.00

UNIT HYDROGRAPH 22 END-OF-PERIOD ORDINATES, LAG= 1.90 HOURS, CP= .81 VOL= 1.00
 5. 17. 32. 48. 63. 76. 84. 87. 84. 77.
 64. 47. 33. 24. 17. 12. 9. 6. 4. 3.
 2. 2.

END-OF-PERIOD FLOW
 NO.DA HR.MN PERIOD RAIN EXCS LOSS COMP 0 NO.DA HR.MN PERIOD RAIN EXCS LOSS COMP 0
 0
 SUM 32.19 29.47 2.72 23855.
 (818.)(749.)(69.)(675.50)

PEAK FLOW AND STORAGE (END OF PERIOD) SUMMARY FOR MULTIPLE PLAN-RATIO ECONOMIC COMPUTATIONS
 FLOWS IN CUBIC FEET PER SECOND (CUBIC METERS PER SECOND)
 AREA IN SQUARE MILES (SQUARE KILOMETERS)

OPERATION	STATION	AREA	PLAN	RATIOS APPLIED TO FLOWS			
				RATIO 1	RATIO 2	RATIO 3	RATIO 4
				.40	.50	.90	1.00
HYDROGRAPH AT	IN	.31	1	499.	624.	1123.	1248.
	(.80)	(14.14)(17.67)(31.81)(35.35)(

APPENDIX

E

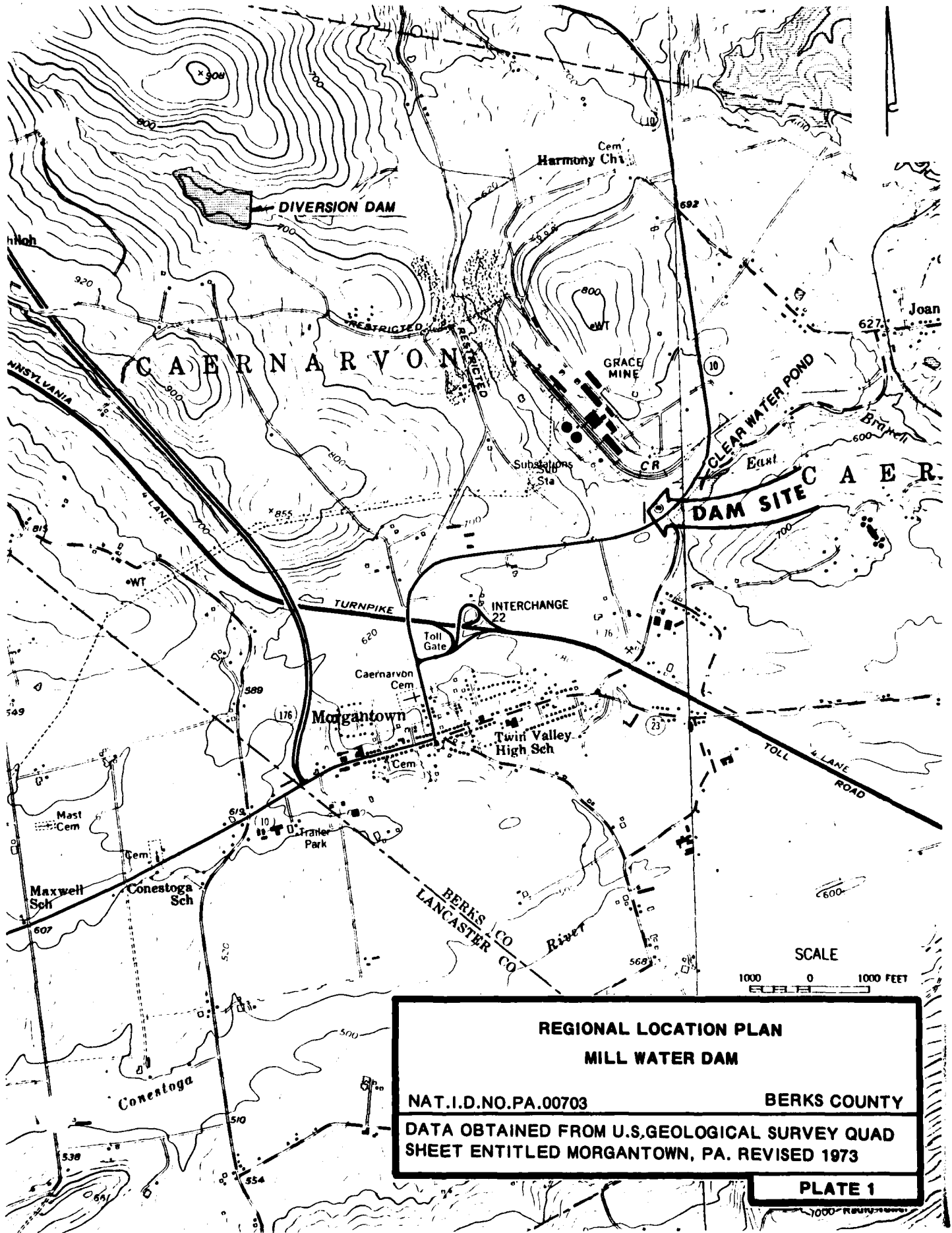

**REGIONAL LOCATION PLAN
MILL WATER DAM**

NAT. I.D. NO. PA. 00703
BERKS COUNTY

DATA OBTAINED FROM U.S. GEOLOGICAL SURVEY QUAD
SHEET ENTITLED MORGANTOWN, PA. REVISED 1973

PLATE 1

• SPOT ELEVATION ON
11/15/79

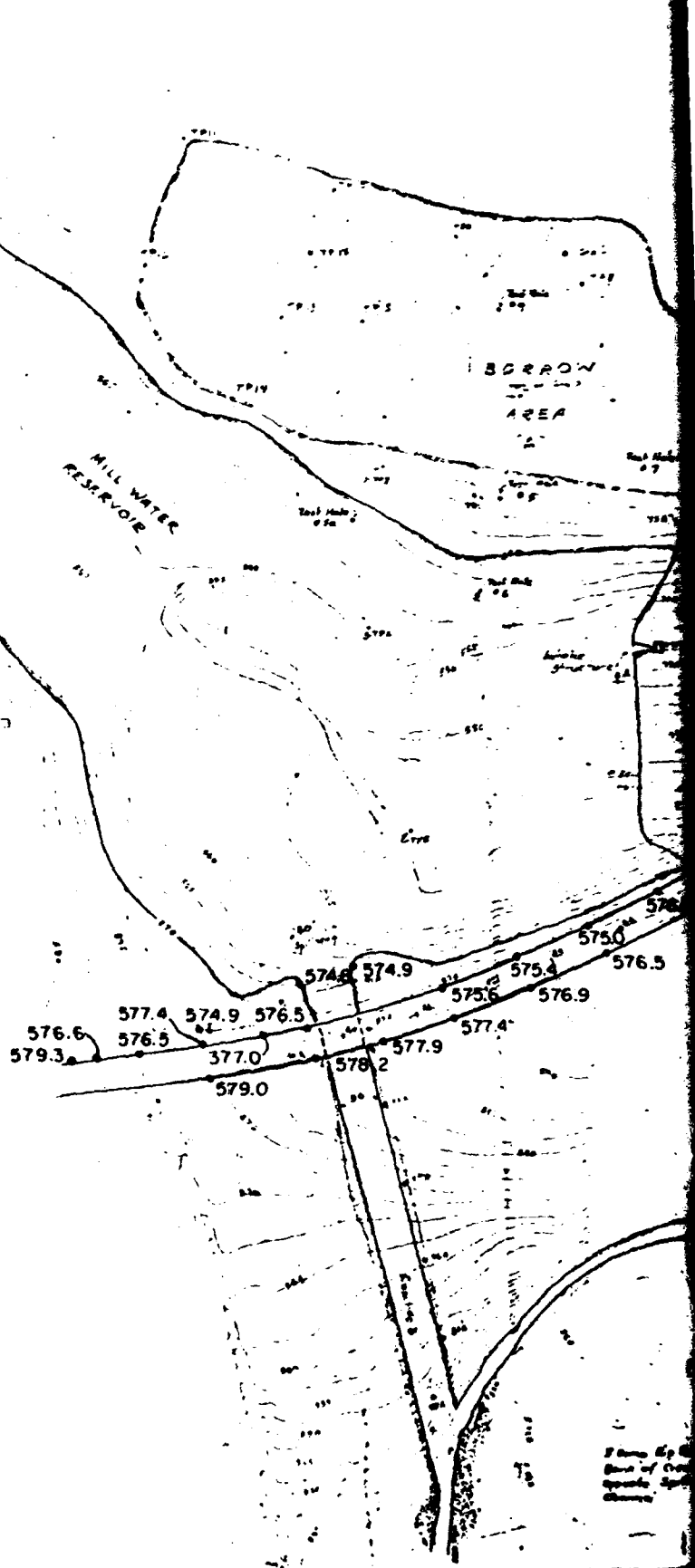

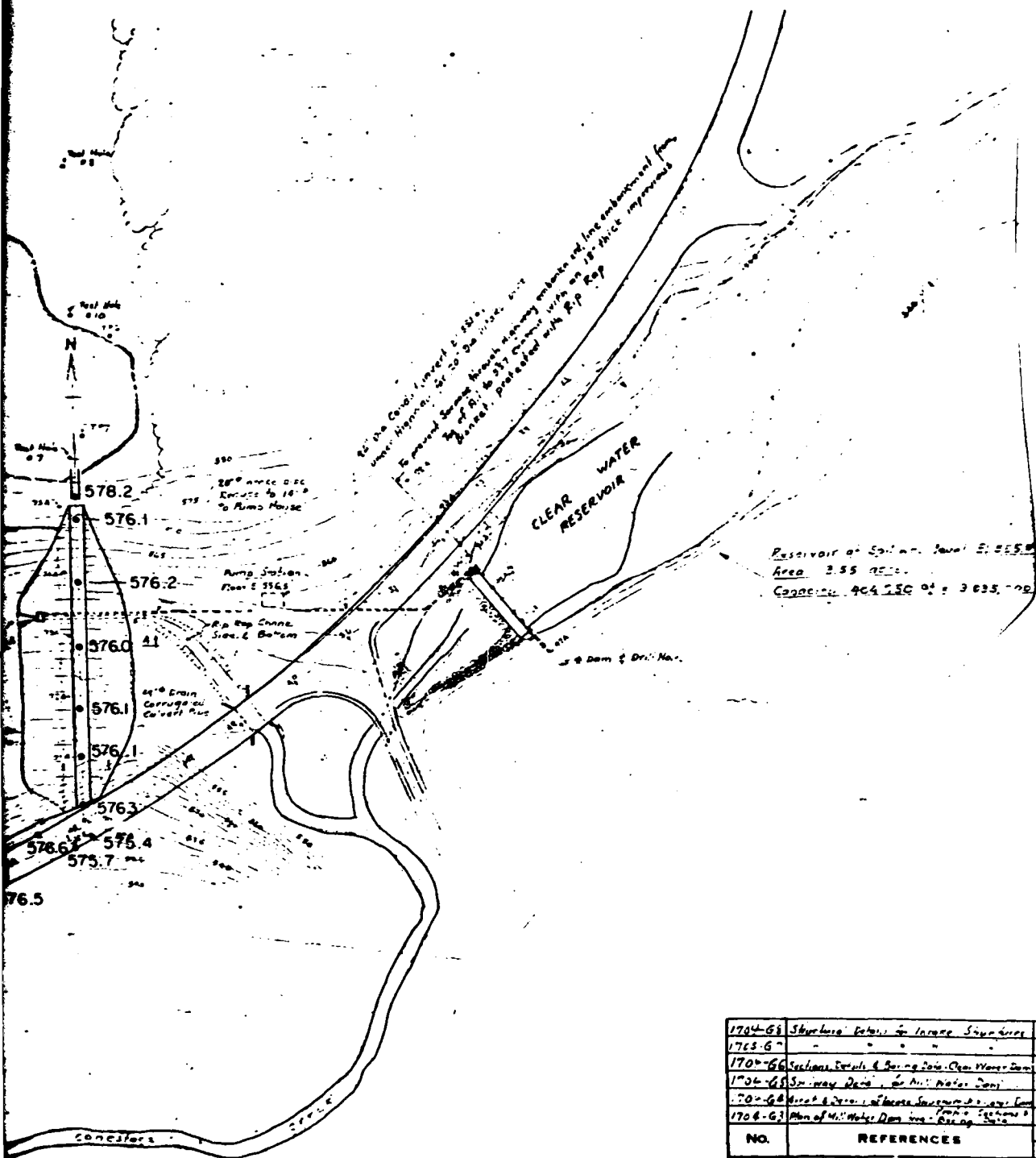

PLAN AND TOPOGRAPHY.
Scale 1"=100'

1704-68	Sketches Detail for Increase Spillway				
1763-67					
1702-66	Sections Details & Spillway Dam Open Water Dam				
1704-65	Spillway Dam, for Hill Water Dam				
1702-64	Detail & Details of Base Spillway Dam				
1704-63	Plan of Hill Water Dam in "Rolling State"				
NO.	REFERENCES	NO.	BY	DATE	
PLAN OF PAPER 1702-64 DAM & SPILLWAY					
GRACE MINE - MORGANTOWN DIVISION					
BETHLEHEM CUBA IRON MINES COMPANY					
OPERATED BY					
BETHLEHEM CORNWALL CORPORATION -					
BETHLEHEM, PA.					
DRAWN	BY	CHECKED	BY	SCALE	AS SHOWN
TRACED	DATE	9-22-24	ORDER	U.S. 1702-64	
APPROVED	W.S. [Signature]			NO.	1702-64

Crest of Spillway El. 570
53' Max. Flood water
10' Reservoir

Drill Hole
91 A

Drill Hole
89 A

Drill Hole
88 A

Drill Hole
87 A

Drill Hole
86 A

Highway Bridge
El. 577

Present Ground Line

Rock
Change

Slope 1%

PROFILE ON & OF SPILLWAY

Scale: Horiz. 1" = 60'
Vert. 1" = 30'

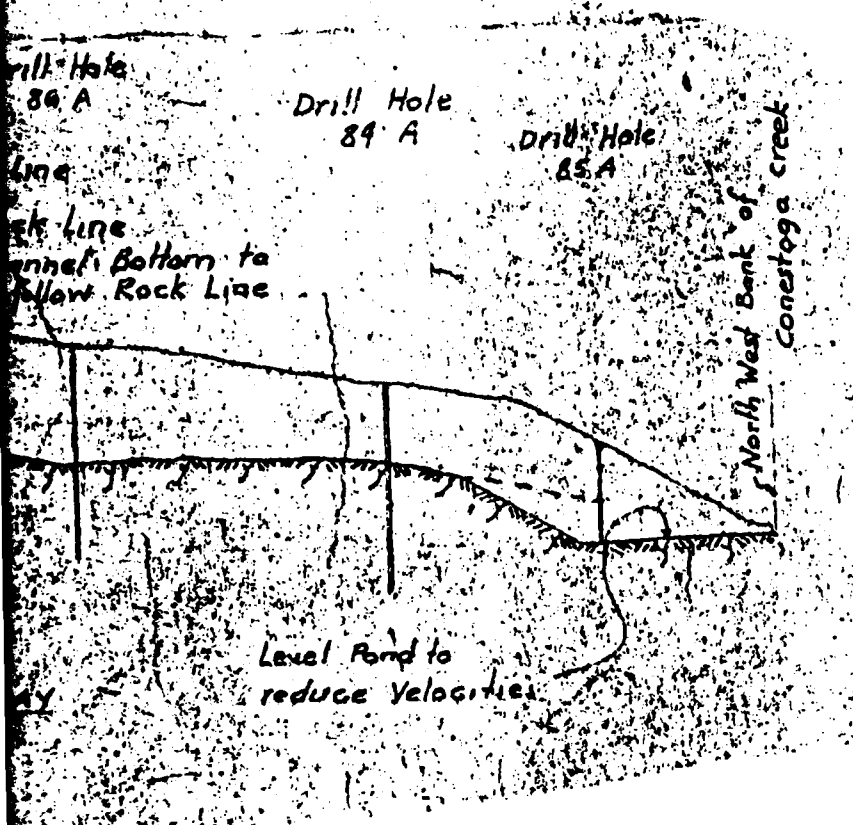

1704-G	Sketches of Pits in Large Signatures			
1765-G	" " " " " "			
1704-G	Sections of Pits & Spring Pits - Cross Section			
1704-G	Sections of Pits - No Drill Hole Log			
1704-G	Plan of Pits - No Drill Hole Log			
1704-G	Plan of Pits - No Drill Hole Log			
NO.	REFERENCES	NO.	BY	DATE
		REVISIONS		
PLAN OF PASSADUNE DRIVE				
GRACE MINE - MORGANTOWN DIVISION BETHLEHEM CUBA IRON MINES COMPANY OPERATED BY BETHLEHEM CORNWALL CORPORATION - BETHLEHEM PA.				
DRAWN	CHECKED	SCALE	DATE	
TRACED	DATE	ORDER	NO.	
APPROVED				

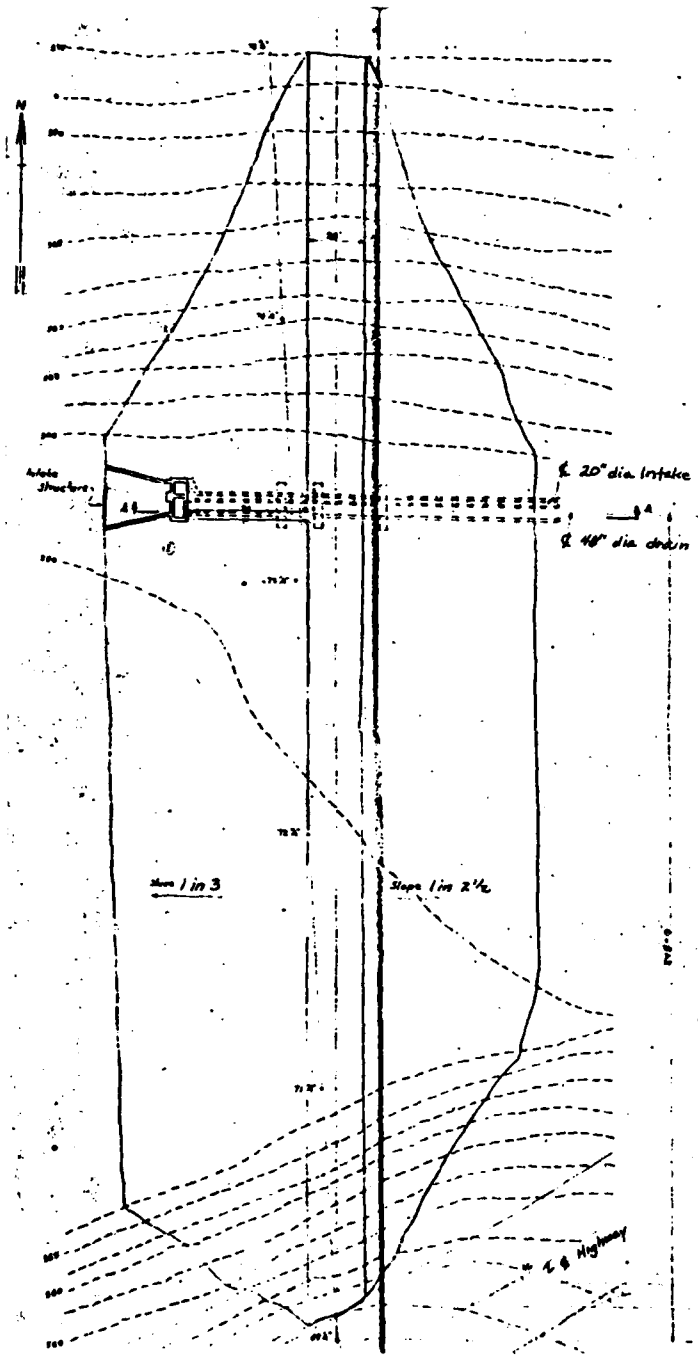

PLAN
SUB-C-102

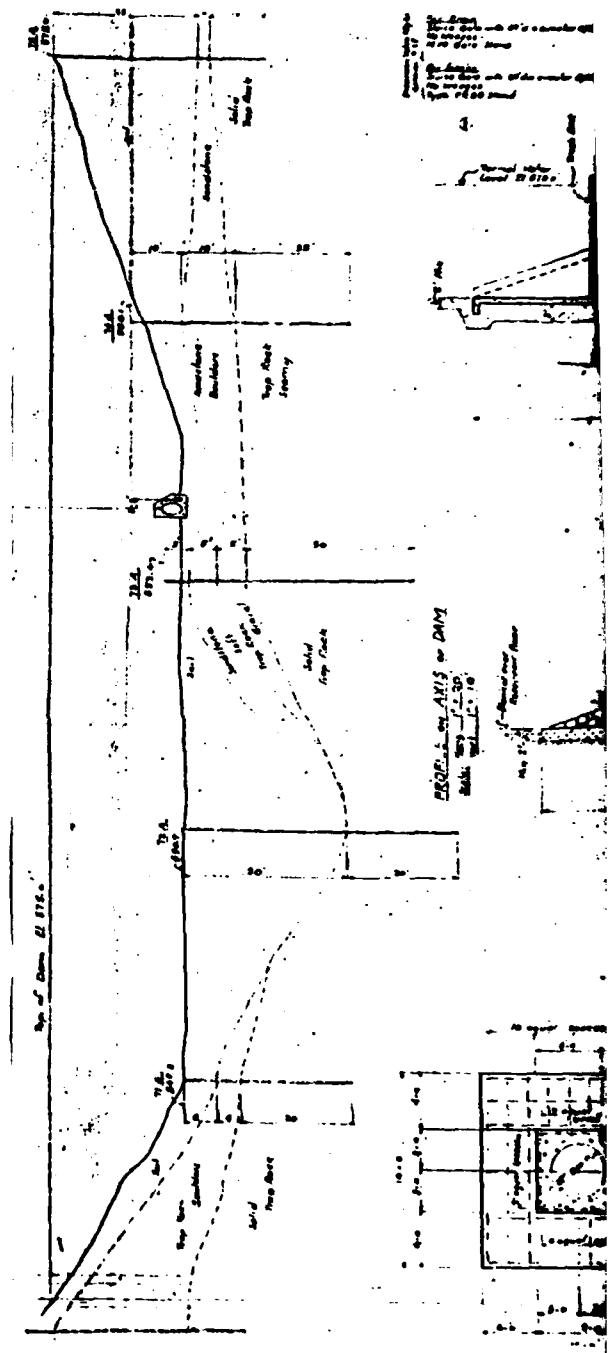

DISEASE AMIS or DAM
 Scale 1" = 200'
 Date 10/10/50

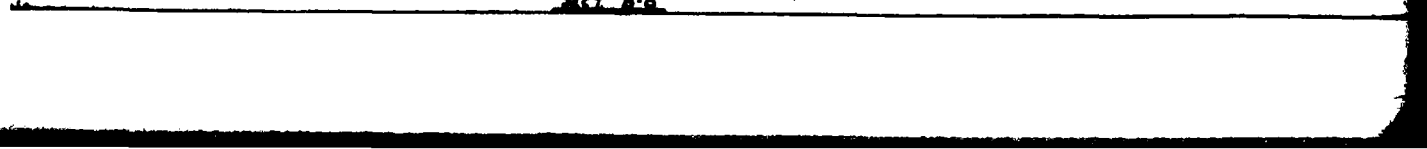
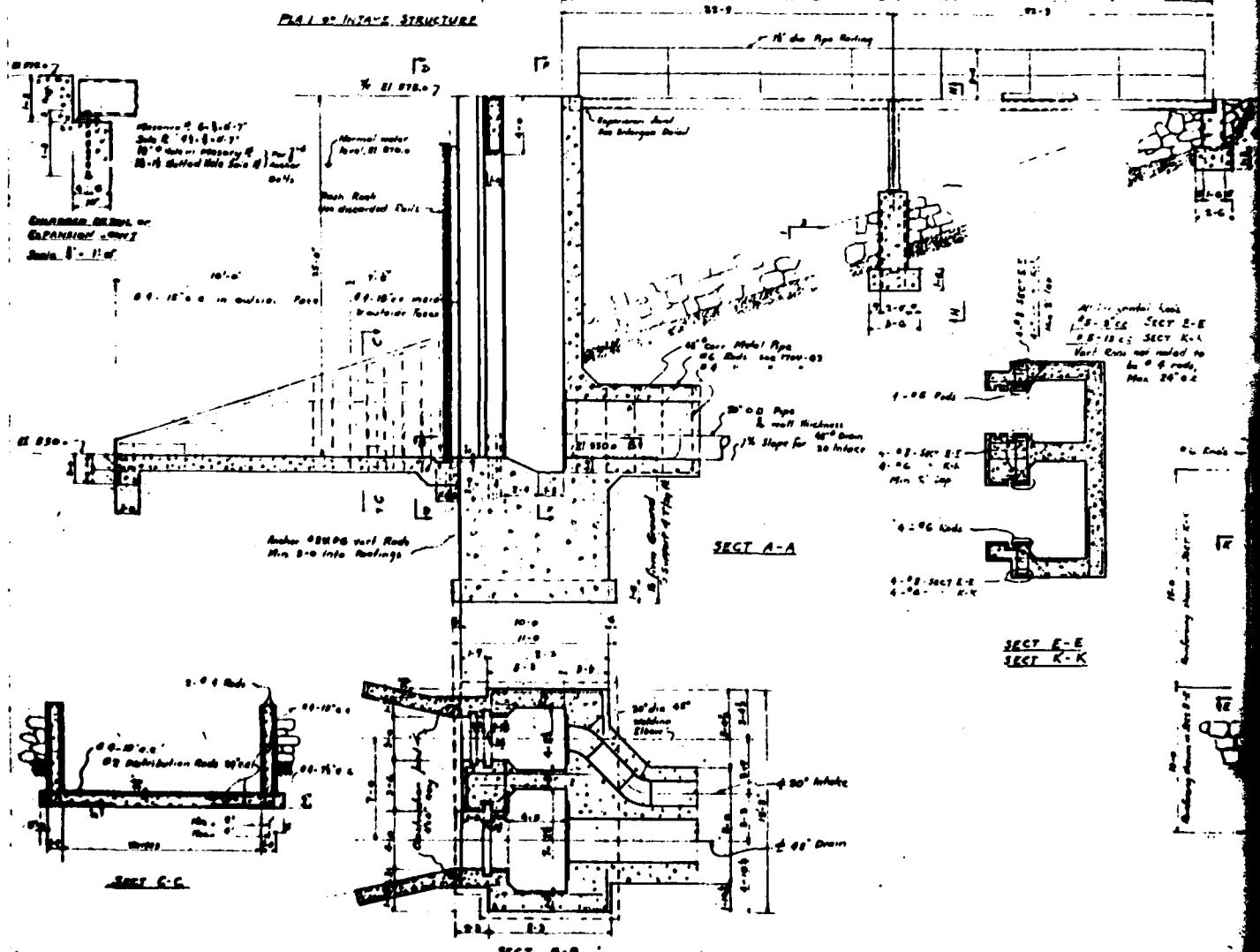
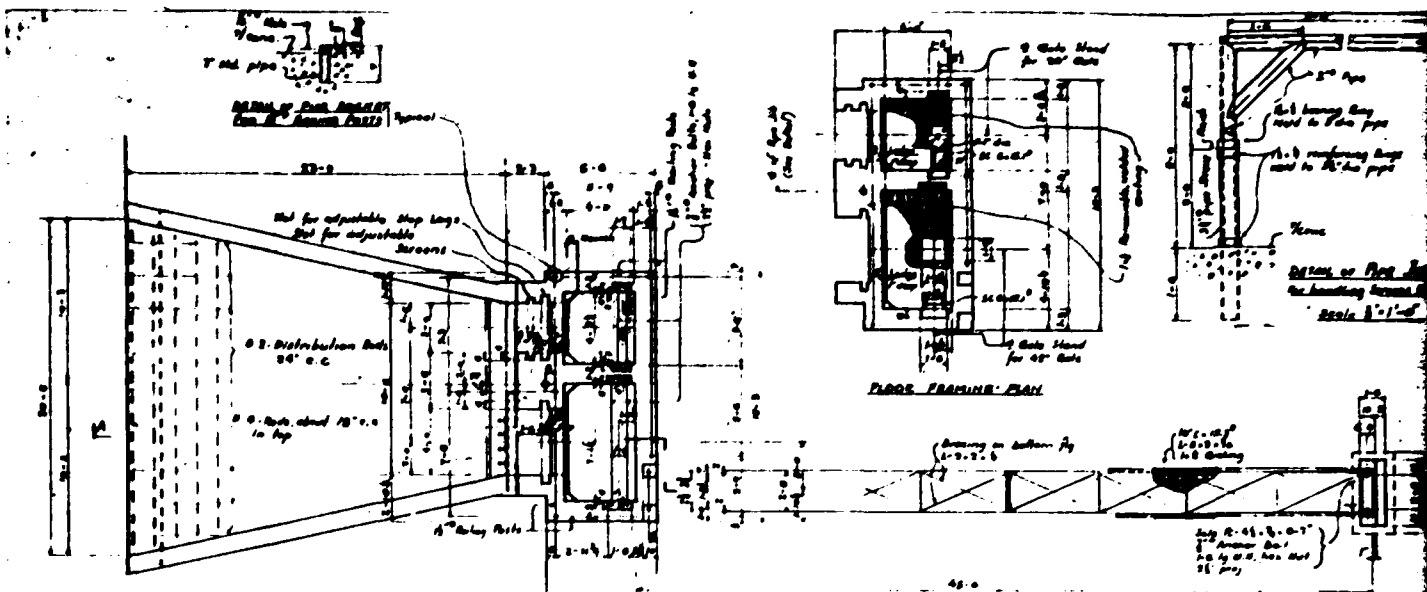

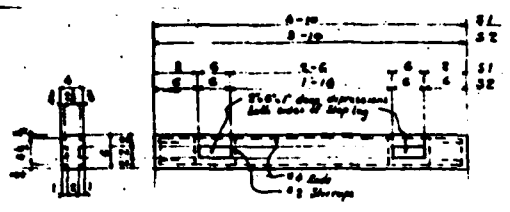

DETAIL OF STOP LOG
 REQUIRED - 41-51
 42-52

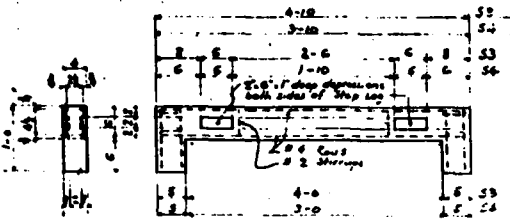

DETAIL OF STOP LOG
 REQUIRED - 41-51
 42-52

Scale 1/2" = 1'-0"

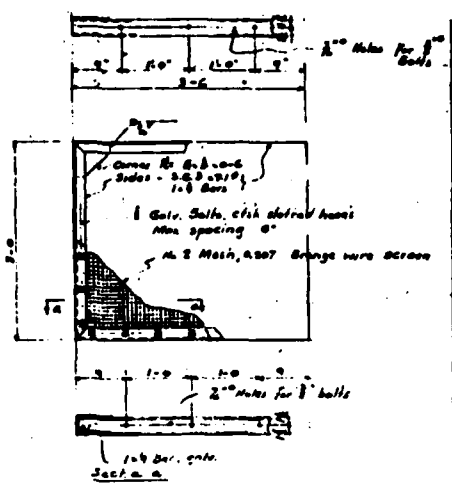

DETAIL OF INTAKE SCREEN REQUIRED
 Plans to be as per 21-50
 Scale 1/2" = 1'-0"

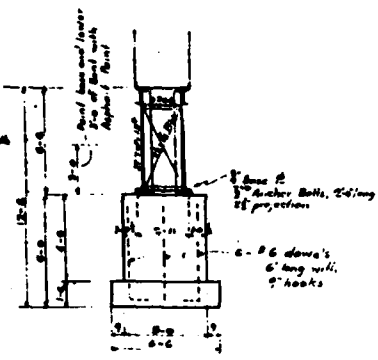

SECT H-H

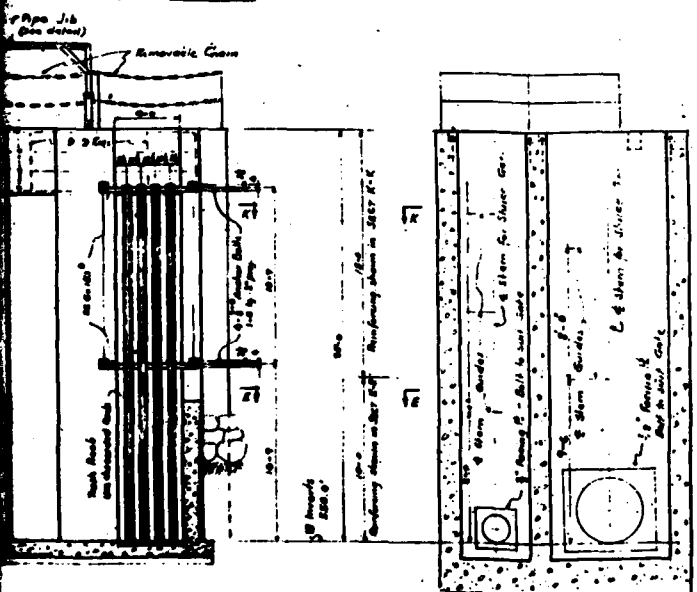

SECT D-D

SECT F-F

Notes:
 Concrete Mix to be approximately 1:2 1/2 : 3 1/2
 using not over 64 gal. of water per bag of cement including proper allowance for moisture in aggregates
 Reinforcing steel to be deformed bars specification A574 #305
 Distance from face of Concrete to reinforcing steel to be 2 1/2" clear unless noted

No.	REFERENCES	REVISIONS
1747-A	Spillway Detail for Millwater Dam	
1748-A	Plan of Millwater Dam Area, 1912	
1748-B	Plan of Dam and Spillway	
1748-C	Topography of Dam site Area	

ARRANGEMENT AND DETAILS OF INTAKE
 STRUCTURE FOR MILL WATER DAM
 GRACE MINE, MORGANTOWN DIVISION
 BETHLEHEM CUBA IRON MINES COMPANY
 OPERATED BY
 BETHLEHEM CORNWALL CORPORATION
 BETHLEHEM, PA.
 DRAWN 712-4-11-07 CHECKED F.C.H. 11 SCALE 1/2" = 1'-0"
 DATE 8-20-24
 APPROVED [Signature] 1704-64

Redrawn

APPENDIX

F

SITE GEOLOGY
MILLWATER DAM

Millwater Dam is located in the Triassic Lowlands Section of the Piedmont Physiographic Province. As shown in Plate F-1, the dam is situated in an area underlain by the Stockton Formation and diabase of Triassic age. While no rock exposures were observed during the field inspection, the Stockton typically consists of arkosic sandstone and shale. The diabase would characteristically be a dense, medium grained intrusive rock.

Immediately south of the reservoir and Route 10, the area is underlain predominantly by solution prone limestone and dolomite formations. The dam is built in close proximity to a previously established southeast flowing drainage. This could in part explain the minor seepage encountered at the right abutment.

ILMED
— 8