

AD-A085 521

CIVIL ENGINEERING LAB (NAVY) PORT HUENEME CA
ELECTROMAGNETIC SUSCEPTIBILITY TESTING OF NEUROPHYSIOLOGICAL EB--ETC (11)

F/S 9/1

FEB 80 J L BROOKS
CEL-TR-876

ML

UNCLASSIFIED

1 of 1

AL 009557

END
DATE
FILMED
7-80
DTIC

LEVEL

12

ADA 085521

DTIC
EXTRACTED
JUN 12 1980

876



TECHNICAL REPORT CIVIL ENGINEERING LABORATORY

Naval Construction Battalion Center, Port Hueneme, California 93043

**ELECTROMAGNETIC SUSCEPTIBILITY TESTING
OF NEUROPHYSIOLOGICAL EQUIPMENT**

By
James L. Brooks

February 1980

Sponsored by
NAVAL FACILITIES ENGINEERING COMMAND

Approved for public release; distribution unlimited.

80 6 9 182

FILE COPY

14

Unclassified

SECURITY CLASSIFICATION OF THIS PAGE (When Data Entered)

REPORT DOCUMENTATION PAGE

READ INSTRUCTIONS
BEFORE FILLING IN FORM

CEI

REPORT NUMBER

TR-876

ADA085521

DTIC087055

TITLE (and Subtitle)

ELECTROMAGNETIC SUSCEPTIBILITY TESTING
OF NEUROPHYSIOLOGICAL EQUIPMENT.

9

PERFORMING ORGANIZATION REPORT NUMBER
Final, Oct 78 - Oct 79

6

AUTHOR

James L. Brooks

10

16

FLD 534

PERFORMING ORGANIZATION NAME AND ADDRESS

CIVIL ENGINEERING LABORATORY
Naval Construction Battalion Center
Port Hueneme, California 93043

17

PROGRAM ELEMENT PROJECT, TASK
AREA & WORK UNIT NUMBERS

YF6053409101.121

CONTROLLING OFFICE NAME AND ADDRESS

Naval Facilities Engineering Command
Alexandria, Virginia 22332

11

REPORT DATE
February 1980

NUMBER OF PAGES

47

MONITORING AGENCY NAME & ADDRESS (if different from Controlling Office)

12 51

SECURITY CLASS. of this report

Unclassified

DECLASSIFICATION/DOWNGRADING
SCHEDULE

DISTRIBUTION STATEMENT (of this Report)

Approved for public release; distribution unlimited.

DISTRIBUTION STATEMENT (of the abstract entered in Block 20, if different from Report)

SUPPLEMENTARY NOTES

KEY WORDS (Continue on reverse side if necessary and identify by block number)

Electromagnetic shielding, hospital construction, neurophysiology,
electroencephalography

ABSTRACT (Continue on reverse side if necessary and identify by block number)

A series of electromagnetic susceptibility tests were conducted on electromyographs,
electroencephalographs, and an echoencephalograph. The tests were to determine the
amount of electromagnetic shielding required to provide the proper operational environment
needed in hospital neurophysiological departments. The results showed that careful
arrangement of the electrode conductors can significantly decrease the susceptibility of

continued

DD FORM 1473 1 JAN 73 EDITION OF 1 NOV 65 IS OBSOLETE

Unclassified

SECURITY CLASSIFICATION OF THIS PAGE (When Data Entered)

391111 Lsu

Unclassified

SECURITY CLASSIFICATION OF THIS PAGE (When Data Entered)

20. Continued

the equipment. In addition, it was found that electromagnetic shielding provides minimum protection for the electroencephalograph because of its limited frequency response. Therefore, it is not recommended unless electromyographs (wide frequency range) are present or their use is anticipated.

Library Card

Civil Engineering Laboratory
ELECTROMAGNETIC SUSCEPTIBILITY TESTING OF NEURO-
PHYSIOLOGICAL EQUIPMENT (Final), by James L. Brooks
TR-876 47 pp illus February 1980 Unclassified

1. Electromagnetic shielding 2. Hospital construction L. YF60.534.091.01.121

A series of electromagnetic susceptibility tests were conducted on electromyographs, electroencephalographs, and an echoencephalograph. The tests were to determine the amount of electromagnetic shielding required to provide the proper operational environment needed in hospital neurophysiological departments. The results showed that careful arrangement of the electrode conductors can significantly decrease the susceptibility of the equipment. In addition, it was found that electromagnetic shielding provides minimum protection for the electroencephalograph because of its limited frequency response. Therefore, it is not recommended unless electromyographs (wide frequency range) are present or their use is anticipated.

Unclassified

SECURITY CLASSIFICATION OF THIS PAGE (When Data Entered)

CONTENTS

	Page
INTRODUCTION	1
BACKGROUND	2
NEUROPHYSIOLOGICAL EQUIPMENT TESTED	2
DESCRIPTION OF SHIELDED ROOM, BETHESDA NMC	4
TEST PROCEDURES	4
Test Conditions	4
Equipment Setup and Measurement Goals	5
Purpose of Tests	6
TEST RESULTS	6
Electroencephalograph (EEG) Machines	6
Echoencephalograph	9
Evoked Response (ER) Signal Averager	10
Electromyographs	10
SUPPLEMENTAL EXPERIMENTS	11
SHIELDING CONSIDERATIONS IN BUILDING DESIGN	13
CONCLUSIONS	14
RECOMMENDATIONS	15
ACKNOWLEDGMENT	15
REFERENCES	15

Accession For	
NTIS GRA&I	<input checked="" type="checkbox"/>
DDC TAB	<input type="checkbox"/>
Unannounced	<input type="checkbox"/>
Justification	
By _____	
Distribution/	
Availability Codes	
Dist	Avail and/or special
A	

INTRODUCTION

The ever-increasing use of electrical and electronic devices in the medical profession has significantly advanced the diagnostic, data processing, and communication fields now utilized by large hospitals. Many regulatory agencies have been studying the hazards associated with the use of electrical and electronic equipment within these buildings and have issued guidelines and recommendations to manufacturers and construction contractors. In many states, these recommendations have been written into the laws, ordinances, and regulations of public authorities, in an effort to provide safe working areas and apparatus for the consuming public. One recent example of this is the solution to the so-called "microshock" problem where, during certain medical operations, the possibility of patient electrocution existed when normal electrical and electronic equipment was used. The discovery of this hazard led to some revisions of the electrical code for hospital construction and numerous recommendations for retrofitting existing hospitals.

The Navy builds, maintains, and operates its own hospitals and seeks the latest in guidelines and recommendations for construction and equipment on a continual basis. Unfortunately, guidelines are sometimes slow in coming, and internal investigations into possible hazards are initiated. For example, recent reports have been made that excessive radiation from microwave ovens and electrical interference cause heart pacer problems. Most of these reports are undocumented primarily because, at the time of the occurrence, the victim and nearby persons are unaware of the cause of the problem and only later surmise what actually happened.

Numerous complaints have been made, however, of medical equipment interfering with other medical equipment. Usually these problems do not represent a direct hazard to life but do affect a patient's well-being in that they cause delay, lost information, possible erroneous diagnosis, and procedural problems.

One of the areas of concern is in clinical neurophysiology, the medical science of obtaining and interpreting tracings of the minute biological potentials of the body and brain. While this is not a new science, it is emerging as an important medical diagnostic tool in the treatment of certain illnesses, such as epilepsy, muscular dysfunction, and other nervous disorders.

Some hospital architects have been specifying shielded rooms and the use of powerline filters in their designs in an effort to prevent electromagnetic interference problems. However, the cost of shielded rooms is high (up to \$60/sq ft of shielding surface), and the uncertainties regarding how much shielding is required make it difficult to justify the cost. It is, therefore, the objective of this study to establish design and performance criteria by which Navy hospital designers can specify and justify the necessary amount of shielding to be incorporated in the neurophysiological clinics of Navy hospitals.

BACKGROUND

The use of electronics in the medical field dates back about 50 years. The development of the X-ray machine started the trend, and the later discovery of bioelectric potentials associated with living cells opened the field for many new types of electronic equipment. One of the most common instruments of this type today is called the electrocardiograph (ECG), which is designed to measure the biopotentials present on a patient's body due to heartbeat activity. The small biopotentials are amplified and presented in analog form either on an oscilloscope or strip chart recorder so that a diagnostic analysis of the waveform may be performed. The biopotentials range in amplitude from 5 to 15 mV, so that quite a bit of amplification is necessary by the ECG machine. Another very similar instrument is the electroencephalograph (EEG), which is designed to pick up and amplify the biopotentials (10 to 100 μ V) on the patient's head that are associated with brain activity. For these devices, more amplification is needed.

Other types of electronic equipment now in common use are the heart defibrillator instrument, the electrosurgical knife, and diathermy machines. These instruments generate electrical energy for direct application to the patient. It is not surprising to find that some of these instruments cannot be used simultaneously with others because of direct electrical interference.

The medical electronics field is increasing daily. For example, a buyer's guide for medical equipment recently was published, based upon product information obtained from 1,500 companies. Over 1,000 different types of products were listed, and most of these products required the use of electricity either for power or signal processing or both.

At present, few regulations or restrictions are placed on the equipment manufacturers to insure that their equipment will be compatible with existing equipment or facilities. Generally, all manufacturers try to comply with the Underwriters Laboratory (UL) electrical requirements and possibly the recent National Fire Protection Association (NFPA) guidelines on the safe use of electricity in hospitals, but no restriction exists to insure that the equipment and environment will be compatible in hospitals. It is generally felt among those in the medical field that electromagnetic compatibility is a matter of shielding. While this is true to a certain extent, it is not always true. Even if it were, no guidelines are established by which the correct amount of shielding can be incorporated into hospital construction.

A study was conducted in 1975 by the Civil Engineering Laboratory (CEL) wherein typical examples of medical equipment were tested for electromagnetic compatibility (Ref 1). Most ordinary medical equipment was included in this test, but the EEG was not tested for various reasons. In order to complete the study, a special test program was initiated and is documented herein.

NEUROPHYSIOLOGICAL EQUIPMENT TESTED

The primary reason for the surge of interest in neurophysiology is the recent application of modern electronics to the measurement of the extremely small biopotentials. Accurate reproduction of biopotentials

as small as one-millionth of a volt is now well within the state-of-the-art. The biopotentials of interest, however, occur at ultra-low repetition rates (0.5-50 pps); as a result, specialized equipment has been developed and named for each particular medical specialty (listed below).

(1) Electroencephalography (EEG). Graphic recording of biopotentials developed in the brain by electrodes applied to the scalp, to the surface of the brain, or placed within the brain.

(2) Electromyography (EMG). Graphic recording of the biopotentials associated with muscle tissue by electrodes placed within the muscle or on the skin surface directly over the muscle being monitored.

(3) Electro-oculography (EOG). Graphic recording of the biopotentials associated with movements of the eyeball by electrodes placed on the skin near the eye.

The clinical equipment used in these specialties is extremely sensitive, and the requirement of placing multiple probes over wide areas of the body (each with an individual conducting wire) causes the equipment to be susceptible to stray electric and magnetic fields. Normally, this problem could be avoided by simply installing conventional shielding and using filtering techniques; however, the ultra-low frequency range and extreme sensitivity renders conventional shielding and filtering techniques virtually useless as a means of providing the proper environment.

As a result, a test program was proposed to quantify and qualify the susceptibility of this equipment in engineering terms, so that by analysis and deduction an effective environment may be specified for Naval hospitals which have neurophysiology departments and facilities.

The items tested are typical of modern neurophysiological equipment. At least three samples of each type were required and were to be from different manufacturers if possible, but were provided from Navy equipment presently in use or in storage. Recent models of each type were preferred - to reflect the present state-of-the-art in equipment - and a list is presented below.

1. Electroencephalographs:
 - Medcraft, Mark III, 8-channel EEG
 - Grass Instrument Co., Series 8 EEG
2. Combination EEG, EMG, and EOG's
 - Beckman Dynograph, 8-channel Recorder
 - Nicolet Instrument Co., CA-1000 system
 - TECA, TE-4 Electromyograph
3. Audio and Visual Evoked-Response Stimulators
 - Medcraft PS II, Photic Stimulator
 - Nicolet NIC-1006 Visual Stimulator
 - Nicolet Audio Tone and Click Stimulator
 - Grass PS-22 or PS-33 Photic Stimulator

DESCRIPTION OF SHIELDED ROOM, BETHESDA NMC

The clinical neurophysiological area of the Neurology Department of the Bethesda NMC contains a shielded room wherein the most sensitive measurements are performed. This shielded room was given a cursory examination to determine the type and construction used. It is a copper-screened room utilizing 1/4-inch mesh copper wire on all surfaces except the floor.

The doors were standard wood doors fitted with phosphor bronze compressible weather stripping V-channel which compresses against the edges of the copper mesh when the door is closed. The door frames were lined with solid copper-clad material so that the compressible weather stripping had a mating material. A brass plate was placed across the bottom of the door frame and made contact with the weather stripping on the bottom of the door. A standard door knob was provided for a handle on the door. No provision was made for mechanical compression forces for closing and latching the door. Three doors led to the shielded enclosure, two of which opened into the room and one which opened out from the room.

The room was outfitted with four fluorescent light fixtures. These were standard fluorescent lights and fixtures except that they were mounted above the false ceiling which had cutouts for the light to shine through. These cutouts were in turn fitted with a removable copper screen (same 1/4-inch mesh size) insert mounted on a wood frame to complete the shielding across the face of the fluorescent lights. The wood frame inserts were held in place with wood screws and were supposed to maintain continuity of contact with the ceiling copper mesh all around the circumference of the insert. Again, no pressure was exerted on the mechanism, making the continuity of the circumferential contact suspect.

Electrical power is brought to the room in conduit just above the entry door and above the false ceiling where it then branches to the light fixtures and wall outlets. All the wiring is in flexible conduit - without power filters in the circuit, however.

TEST PROCEDURES

Test Conditions

A study of documents (Ref 1, 2) on the subject of neurophysiological pulse waveforms shows a frequency spectrum for each category as depicted in Figure 1. The equipment manufacturers have designed their signal input amplifiers to pass all frequencies indicated without attenuation. Therefore, the susceptibility tests must extend from 0.1 hertz to 5 kHz.

In the test the patient/machine interface was simulated by utilizing a lifesize styrofoam ball for the patients head with 5 K Ω resistors between connection points as shown in Figure 2. The exact connection points to be used varied for each test, depending upon the recommendations of a practicing neurologist just prior to start of the tests.

Special test apparatus was fabricated so that a standard magnetic field of known magnitude and direction could be generated to flood the machine/patient interface test sample. The frequency of the magnetic field was varied from 0.1 hertz to 10 kHz for three-dimensional orientations of the test sample. The response of the test sample to the incident magnetic field was recorded along with the magnetic field strength and sample orientation. This procedure was repeated for all samples.

The shielded room was then outfitted so that a standard electric field of known magnitude and direction could be generated to flood the machine/patient interface test sample. The frequency of the electric field was varied from 0.1 hertz to 10 kHz for three-dimensional orientation of the test sample. The response of the test sample to the incident electric field was recorded along with the electric field strength and sample orientation. This procedure was repeated for all samples.

For those machines which were too large to be placed inside the standard magnetic field generator, a small magnetic field search coil was used to search the case of the machine incrementally.

As a final test, all test samples were subjected to a conducted susceptibility test to determine whether or not powerline filters were required. The conducted susceptibility test consisted of spike voltages of 100 volts, in accordance with MIL-STD-462.

Equipment Setup and Measurement Goals

The neurophysiological equipment susceptibility was to be determined by performing the following series of measurements on each test sample.

- a. Electric field susceptibility levels (0.1 hertz-10 kHz) of the simulated patient/machine interface.
- b. Magnetic field susceptibility levels (0.1 hertz-10 kHz) of the simulated patient/machine interface.
- c. Magnetic field susceptibility (0.1 hertz-30 kHz) of the machine case.
- d. Conducted spike susceptibility of the machine power supply and lines.

The electric field susceptibility test setup for the simulated machine/patient interface is shown in Figure 3. The goal of this test was to determine the level of electric field, in volts per meter, required to cause a deflection of the recorder pens equal to that caused by a normal biopotential. At least one data point was taken for each octave of frequency between 0.1 hertz and 10 kHz. The simulated patient head and leads were then rotated and the test repeated to obtain information from all three directions of electric field orientation.

The magnetic field susceptibility test setup for the simulated machine/patient interface is shown in Figure 4. The goal of this test was to determine the level of magnetic field strength in gauss required to cause a deflection of the recorder pen equal to that caused by a

normal biopotential. At least one data point was taken for each octave of frequency between 0.1 hertz and 10 kHz. The simulated patient head and leads were then rotated and the test repeated to obtain information from all three directions of magnetic field orientation.

The magnetic field susceptibility of the machine itself was determined as shown in Figure 5. The search coil (loop) is a standard coil with construction details as shown in Figure 6. The coil generates a standard magnetic field of 0.5 gauss/amp at the base of the coil form (Ref 3). The coil was placed on each face (top and sides) of the machine, and the current through the loop was increased until a deflection of the recorder pen equal to that of a normal biopotential occurred. At least one data point for each octave of frequency between 1 hertz and 10 kHz was taken. The current through the coil was monitored by measuring the voltage across the 1-ohm resistor in the lead as shown in Figure 5.

The conducted susceptibility of the machine powerlines/supply was measured using the test setup shown in Figure 7. A standard spike voltage, shown in Figure 8, which represents a broad spectrum of signals, was injected into the AC powerlines to determine susceptibility quickly. Most neurophysiological equipment contains a powerline filter; therefore susceptibility to the spike voltage was not expected. In the event susceptibility was demonstrated, the spike generator was replaced with a power sinewave oscillator to determine the filtering requirements. These requirements were recorded as test data.

Purpose of Tests

These tests were designed to determine the vulnerability of the neurophysiological equipment to ultra-low frequency electric and magnetic fields which may reasonably be expected in the hospital environment. By using controlled laboratory experiments, the susceptibility of the equipment under test could be accurately specified for both radiated electric/magnetic fields as well as conducted signals on the powerlines.

From the test data, an engineering analysis was made to determine the shielding and filtering requirements for proper location, layout, and design of the neurophysiology departments of Naval hospitals.

TEST RESULTS

Electroencephalograph (EEG) Machines

The electroencephalograph machines are basically audio amplifiers with recording pens as output indicators. They are designed to have numerous channels ranging from 8 to 18. Each channel has individual controls for gain, bandwidth, and input connections. The standard gain setting of 7.1 mm P-P/50 μ V of input signal was used as a reference or "standard response." This response level was used to determine the susceptibility or nonsusceptibility of the machine. While it is recognized that a single-valued threshold such as this does not exist, it does provide a common number to compare the responses of all machines.

The styrofoam head was wired as shown in Figure 2. All connections were soldered to insure good connections, and the earlobe connection (white wire) was considered the reference point. The styrofoam head was then placed in the center of the magnetic field coil structure. The signal generator was set to 15 hertz, and the signal output was adjusted upwards until a standard 7-mm response was obtained. This procedure was repeated at 5-hertz intervals to cover the bandwidth of the recorder. At 200 hertz the recording pens could no longer respond so all further tests were limited to 200 hertz and below.

In order to test all channels of each machine, with only three input leads and one reference lead, it was necessary to parallel many of the channels. It was interesting to note that differences in channel gain as large as 2:1 were common even though the gain of each channel was "standardized" prior to each test. This, plus the fact that the three input lead responses were each slightly different, resulted in a spread of data points which can best be presented as upper and lower limit curves on a plot.

Figures 9, 10, 11, and 12 show the results of the magnetic field susceptibility tests. The area above the top curve represents magnetic field strengths which will cause interference to all channels while the area below the bottom curve represents magnetic field strengths which will not interfere with any channels. Of course, the area between the curves represents the magnetic field strength which will interfere with one or more of the channels. Observe that the most sensitive frequencies for each channel is 50 to 70 hertz on all machines. Note also that the minimum magnetic field strength which will not cause interference is 1×10^{-2} gauss which occurs at 60 hertz on the 10-channel machine (Figure 10). This number, therefore, represents the maximum allowable ambient field strength for 60-hertz magnetic fields within the neurophysiological clinic area.

The magnetic field generating apparatus was then dismantled and replaced by the electric field generating apparatus. The susceptibility tests were repeated with the same styrofoam head and lead connections for each machine. The test results are shown in Figures 13, 14, 15, and 16. Observe that the curves are similar in shape, and the most sensitive point occurs at 4 V/m at 60 hertz on the 8-channel machine (Figure 13). This value may then be taken as the maximum allowable ambient electric field strength for 60-hertz electric fields within the neurophysiological clinic.

It was observed during these tests that the conductors responded much more to the magnetic fields than to the electric fields, especially as to position relative to each other. This probably was to be expected since the area between any two conductors constitutes a loop area and any loop will respond to a magnetic field proportional to its loop area and orientation to the magnetic field. In view of this fact the magnetic field generating apparatus was set up again, and an experiment was designed to investigate the sensitivity factors associated with the conductor orientation and effective loop areas.

The conductor leads were measured at 50 inches in length which meant that a very wide separation could be made between conductors. A 24-inch circular piece of cardboard was cut, and the wires were separated

and taped along the circumference as shown in Figure 17a. This configuration, which represents the greatest possible separation, was then placed in the magnetic field; the field levels required to produce a standard deflection were recorded.

A reverse situation was simulated by removing the conductors from the cardboard circle and bunching them together. The conductors were held in close proximity by placing them inside a piece of clear plastic tubing which had been slit down its length and enveloped around the conductors as shown in Figure 17b. This configuration represented the minimum loop area between conductors and was inserted into the magnetic field to measure the field strength required to produce a standard pen deflection.

The results of these tests are rather dramatic and can be summarized by the curves in Figure 18. The top curve is representative of the susceptibility of the EEG machine to magnetic fields when the lead conductors have minimum loop area, and the bottom curve is representative of the susceptibility of the same machine to magnetic fields when the loop area is maximum. The curve in the center is an averaged response curve for the same machine when the leads are allowed to hang loosely as normally is done.

In comparing the upper and lower curves, it becomes apparent that there is a factor-of-100 difference in the magnitude of the magnetic field which produced the response and a factor of 10 between the upper curve and the middle curve. Obviously a factor-of-10 decrease in susceptibility can be achieved just by changing the way the leads are bundled.

As a further test of the equipment susceptibility to magnetic fields, a small search coil was used to search the body of the EEG machines. The search coil construction is shown in Figure 6, and the method of measurement is shown in Figure 7. The search coil was slowly moved over all surfaces of each of the machines and whenever a response of the recorder pen was noticed the location of the search coil was noted. Some locations on the machines demonstrated susceptibility to the search coil, principally in the region of the lead switching matrix and the amplifier input sections. However, invariably the most sensitive portion of the machines were the input leads themselves. The output section of the amplifiers and the recording pens were not susceptible to the search coil magnetic field. The rear and side panels were searched including the power cords but to no avail. Clearly, the EEG machine was many times less susceptible to stray magnetic fields than the input leads once they are connected to a patient and form a loop.

A conducted susceptibility test was run on all of the EEG machines. In this test a spike was introduced on the powerline to see if it would affect the recording amplifiers. The test setup is shown in Figure 7. A 100-volt peak, 50- μ sec duration spike was introduced on the powerline, and its repetition rate was varied from 0.5 to 500 pps. Next the spike was synchronized to the powerline and slowly positioned at all electrical degrees of the power waveform. None of the machines exhibited susceptibility to the conducted spike.

A similarly conducted test was then run, using a power sinewave oscillator instead of the spike generator. The sinewave output was varied from 15 to 180 hertz for each of the EEG machines and, again, no susceptibility was demonstrated. The EEG machines had been set to maximum sensitivity on all channels for these tests.

The EEG machines are sometimes used while the patient is subjected to a stimulus of some sort. Often the stimulus is a visual one (such as a flashing light) or an audible one (such as a clicking sound). An available photic stimulator was connected to one of the EEG machines as shown in Figure 19. The lamp was positioned about 8 inches from the styrofoam head, and the equipment was turned on. The two power cords were plugged into the same power receptacle, and the event marker cable was connected to the channel A event marker receptacle. The entire system was then searched with the small search coil while all equipment was turned on at standard sensitivity levels. No evidence appeared of increased susceptibility to magnetic fields due to the use of the photic stimulator and its associated cables.

One of the EEG machines has provision for a plug-in plethysmograph, which is a volumetric low pressure transducer used for respiratory studies or peripheral circulation studies. The details of the plethysmograph model PT5 are shown in Figure 20 (note the use of shielded conductors in the hookup and that the amplifier sensitivity is greatly reduced for this application). The plethysmograph and a calibration unit were placed between the magnetic field generator coils and also between the electric field generator plates with no sign of susceptibility to either.

All of the EEG machines are equipped with 60-hertz noise filters on each input channel. These filters are designed for switching in or out and are located in front of each amplifier. A final test on one of the 18-channel machines was arranged to examine the effect of the filter on the susceptibility of the machine to radiated electric fields. The dummy head was wired to the machine as previously described and placed between the electric field generating plates. The power oscillator was set to sweep downward from 200 to 15 hertz at a slow rate of speed. The electric field strength was held constant at 10 V/m, and the response of the machine was recorded with and without the 60-hertz filter. Figure 21 represents the equivalent response in terms of electric field strength required to cause a standard pen deflection. The effect of the 60-hertz filter is dramatically shown by these two curves.

Echoencephalograph

One echoencephalograph was available at the EEG clinic. It was an H.P. model 7215A dual-channel unit with eight coaxial cables that connect the transducer units to the main unit. The echoencephalograph was turned on and set to normal sensitivity with the transducer resting on a calibration block of Lucite material placed in the middle of the magnetic field generating coils. Since the echoencephalograph is basically an oscilloscope, it can respond to very high frequency signals. Therefore, the power oscillator driving the magnetic field coils was varied from 15 hertz to 150 kHz with no visible interference to the normal pulse trace. The amplifiers of the machine were switched to maximum sensitivity and the test was repeated again with negative results. The power oscillator was replaced with a radio frequency signal generator which had a much higher frequency range but a lower power output. The echoencephalograph began to demonstrate some interference above 300 kHz. This occurred for both the magnetic and electric fields and was later verified with the small search coil. The high frequency signal caused a broadening of the trace with maximum broadening up to 1 cm. The weak points were the

channel A and B input jacks with or without the transducers plugged in. In addition, the power cord demonstrated some susceptibility at 1 mHz, which was the maximum frequency available.

While this susceptibility was not really serious, it is the kind of susceptibility that a shielded and filtered room can prevent as long as the source of the interference is outside the room.

Evoked Response (ER) Signal Averager

The Nicolet evoked response signal averager is a specialized and complex piece of equipment designed to measure a single waveform. The waveform of interest is generated within the brainstem of the subject and is detected with electrodes in the region of the head and neck of the patient. The waveform (ER) of interest is caused by a visual or audible stimulus which is repeated in a synchronized manner with the recording equipment. In general, a single presentation of a stimulus does not produce an ER larger than the normal electrical activity of the brain (EEG waves). In order to enhance the amplitude of the ER signal relative to the normal brain activity noise, the stimulus is repeated many times. Each presentation is separated by an interval which allows the brain to return to its unperturbed state. The individual ER's are electronically superimposed (sampled and averaged) which has the desired effect of emphasizing the ER (coherent addition) while de-emphasizing the background brain activity (noise) which is unrelated to the ER.

This instrument is not an analog device. It is, instead, a digital computer which samples input analog signals, stores the information bits, and then averages them for display. In view of the manner in which this machine operates, it was not expected that the machine would be susceptible to stray electric and magnetic fields in the ordinary sense since all input signals are chopped, stored, and processed prior to display. In spite of the extreme sensitivity of the machine, the only possibility for interference exists when the frequency of the interfering signal happens to be a multiple of the sampling rate. In order to verify this, a simple test was arranged as shown in Figure 22. The calibration pulse generator was used as a source of standard signal while the small search coil was moved about the instrument and leads. As indicated in Figure 22 the only region of the machine which demonstrated any susceptibility was the input leads. These are 6-inch leads which are permanently attached to the pulse calibration unit. The machine demonstrated susceptibility to the magnetic fields in the manner expected and as shown in Figure 23. Note that an interference signal must be a multiple of the sampling rate before it does any more than simply broaden the base line pulse. Unfortunately, the machine developed power supply troubles, and further testing was discontinued. It should be noted that, again, it is the leads which were responding to the magnetic field; and the comments about the EEG machines regarding loop area are applicable in this case as well.

Electromyographs

Two electromyograph machines at the neurophysiological clinic are available at Bethesda NMC. One was manufactured by Medical Instruments Co. and the other by TECA, Inc. These machines are very sensitive and

fast (wideband) devices designed to respond to the minute potentials generated by muscle activity as picked up by surface electrodes or needle electrodes inserted either under the skin in the vicinity of the target muscle or within the muscle itself. Two types of needle electrode combinations are used - the two-needle and reference electrode combination or the bipolar needle with a reference electrode. The bipolar needle is a coaxial combination of needles, with one built inside the other.

Since electromyograph recordings may be taken on any part of the patient's body, the equipment is constructed with a preamplifier built on the end of an extendible arm, into which the electrode wires are plugged. The electrode wires themselves are 23 inches in length, which is approximately one-half as long as the EEG electrode wires. In order to simulate the patient's skin resistance, 5K resistors were used between the surface electrodes, as shown in Figure 24. For the needle electrodes, a sponge soaked in saline solution resting in a bowl was used, with the needle electrodes inserted into the sponge, which was resting on the reference electrode. The same sponge was used for the bipolar electrode and both configurations are shown in Figure 24. Both electric field and magnetic field susceptibility tests were run on both machines in a manner similar to that performed on the EEG machines. The input filters were adjusted to provide the widest possible bandwidth and the susceptibility of the machines was measured at selected frequencies throughout the bandwidth. The results of these tests are shown in Figures 25 through 28. Note that because of the wider bandwidth, the electromyograph machines are much more susceptible to both the electric and magnetic fields than the EEG machines. Also note that the Medical Instrument Co. machine appear to be bandlimited at about 10^4 hertz while the TECA machine bandwidth exceeds 10^5 hertz. While it is unlikely that either machine is ever utilized in a wide-open mode, if it were, then it should certainly be operated within a shielded enclosure.

The electrical resistance between electrodes was measured at 40 to 70 k Ω and seemed to fluctuate considerably. This was particularly a problem in conducting the electric field tests since the machine is so sensitive. The bipolar needle measured 200 k Ω between the inner and outer needle, making it an extremely sensitive probe and leaving some doubt about the validity of the test results. As a matter of fact, for the electrical field tests on the TECA machine the results for the bipolar needle are not plotted.

SUPPLEMENTAL EXPERIMENTS

An interesting experiment was run in the shielded room. The early model 8-channel EEG machine was set up and turned on. Then various pieces of electrically operated equipment were brought in the vicinity of the EEG machine and its leads; operation was then begun.

A 1/6-hp electrical motor suction pump was the first item. The very presence of the motor when it was plugged in and in the vicinity of the leads caused an obvious deflection of the recording pens. When the motor was turned on and running, the pen deflections did not increase. More experimenting with the test setup revealed that the source of the interference was the power cord itself, and the presence of the motor made no difference even when the motor was turned on.

Another item brought into the vicinity of the EEG machine was a transistor radio with a 6-foot power cord. Again, it was found that the power cord caused significant interference when in the vicinity of the EEG leads; whether the radio was turned on or not made no discernible difference.

The last piece of equipment brought into the vicinity of the EEG machine was an electrosurgical cutting machine (Bovie), which is well-known for its interfering characteristics. It is, in effect, a powerful radio transmitter which puts out a broad spectrum of signals in the radio broadcast band. These signals are both radiated and conducted onto the powerlines. While Bovie machines are not ordinarily used in the vicinity of EEG machines, and the spectral output of the Bovie is considerably above the frequency response of the EEG machine, the two machines were brought close together and operated to see what would happen.

As it turned out the interference problem was not as bad as one would expect. The cutting knife and return electrode of the Bovie machine had to be brought very close to the EEG leads (approximately 1 foot) before any discernible interference was noticed. The EEG machine was set at standard sensitivity and the Bovie machine power output was set to the cut mode of operation (3.5 on the dial, which is the recommended cutting power setting). The response of the EEG recording needles was a series of pulses ranging as high as 20 mm in amplitude and 33 msec in duration at the base with a repetition rate of 0.2 seconds. For the most part, all of the pulses were unidirectional. In the coag mode of operation, the response was similar but of less amplitude (7-mm deflection). Different orientations of the cutting needle lead and the patient ground return lead were tried but had no effect. Nearness to the wired patient head was the important factor for the Bovie machine as far as radiation susceptibility was concerned.

As a susceptibility test, the Bovie machine was plugged into the same outlet that the EEG machine was plugged into. The cutting needle and ground wire were removed a distance from the dummy head and the Bovie turned on. This produced very large deflections in the cutting mode and smaller deflections in the coag mode: 25-mm pen deflection in the cut mode (enough for the pens to overrun each other) and 10 mm in the coag mode. The dummy head and wiring harness was disconnected to insure that a conducted interference was being recorded, and the test was repeated. Again, the same level of interference was recorded. Next, the Bovie machine was plugged into a different wall outlet but inside the same room. The machine demonstrated some susceptibility, but the magnitude was very reduced. Apparently a very low frequency (5 Hz) can get by the power supply filter of the EEG machine and interfere with the signal processing going on in the amplifiers.

Another interesting experiment was conducted which provided some insight into the amount of shielding that the existing shielded room provided at 97 kHz. An instrument called a "sniffer" was borrowed for this test. A sniffer is, in essence, a fixed-frequency radio receiver designed to measure the magnetic field strength at localized points. It has a small coil approximately 3/4 inch in diameter located on the end of an 18-inch rod which serves as the magnetic field sensor. It is normally used to locate small holes and cracks in solid shielding materials, but is almost useless when dealing with a wire mesh shield because the

wire mesh leaks everywhere. However, another test can be performed where an outside signal source (loop) can be set up and the sniffer arranged for maximum pickup at a 2-foot distance on an even horizontal line to establish a reference signal level. The equipment is then moved so that the vertically shielded room wall bisects the 2-foot horizontal distance (the receiver inside the shielded room), and another reading is taken. The difference between the two readings is a relative measurement of the effectiveness of the magnetic field shielding of the wall at that point and at 97 kHz.

This test was performed at the doors of the shielded room which averaged 18 db at 97 kHz. The test was also run on a wall which had no doors but did have the standard lath and plaster wall construction as well as the wire mesh. This wall provided 30 db at 97 kHz. While these readings may not be taken as precise measurements, they are in line with what may be expected in the way of magnetic shielding effectiveness from a room of this type and age.

SHIELDING CONSIDERATIONS IN BUILDING DESIGN

In considering the use of shielding in hospital construction, it is appropriate to first review the current state-of-the-art in the now mature shielded room industry. It can be shown (Ref 3) that the shielding effectiveness of any material is a function of $(\omega\mu\sigma)^{1/2}$, where ω is the angular frequency of the radio frequency wave, μ is the permeability of the shielding material, and σ is the conductivity of the shielding material. Therefore, shielding effectiveness can be increased, by carefully choosing materials that have either a high permeability such as sheet steel, or a high conductivity such as copper, or by a combination of both materials. In addition, certain exotic materials could be used that have an extremely high μ (Ref 4). However, due to material and labor costs, the shielding industry has settled on the use of sheet steel and copper as the two basic building materials.

Some improvements in shielding can be accomplished by special construction techniques, such as using double shields, isolated double shields, and combinations of the two basic materials. A good description of the advantages to be gained by different construction techniques is given in Reference 5.

It is important to emphasize that regardless matter what material or construction technique is used, the shielding effectiveness is a function of frequency; that is, the shielding effectiveness increases as the frequency of the radio signals increases. Because of this, the shielding that can be expected at the lower frequencies, such as 60 hertz, is quite small. The shielding obtained by a given installation is the sum of the reflection loss provided by the material plus the penetration loss. Unfortunately, the penetration loss is almost non-existent for frequencies below 1 kHz. At 60 hertz the best that can be hoped for is 25 to 30 db of shielding due to reflection loss (Ref 1).

The costs of providing good shielding range from \$40 to \$60/sq ft of shielding surface, depending on the type of construction and the size of the room. These prices assume that the shielded room is being designed

into a hospital. If the room is being retrofitted into an existing hospital, the cost figures will be higher to reflect the added cost of preparatory building modifications.

A chart of shielding effectiveness at 100 hertz for various construction techniques is shown in Table 1. This chart shows the problems associated with each type of construction and the relative shielding effectiveness to be expected. It is apparent from this chart that a copper screen room is almost as effective as the most expensive type but costs approximately one third as much. Maintenance problems exist, however, that in effect are a cost but are not reflected in this chart. Most of the maintenance problems are associated with the doors and vents into the room which gradually lose their electrical peripheral contact with wear and aging.

It should be noted that the shielding values given in Table 1 are derived from theoretical curves based on shielding factors only. In real life, an additional problem exists which will result in lower obtainable attenuation values due to the fact that existing powerline filters do not attenuate signals below 1 kHz. Therefore, in many instances, the low frequency interference is introduced directly into the room by the power wiring whether filters are provided or not. The problem of low frequency powerline filtering must be solved before the theoretical values of shielding effectiveness can be achieved.

CONCLUSIONS

1. All of the equipment which uses lead wires and electrodes to connect directly to the patient demonstrated a high susceptibility to low frequency electric and magnetic fields at the equipment/patient interface.
2. The susceptibility to magnetic fields was found to be a function of the lead wire loop area. By minimizing this loop area, the susceptibility could be decreased by a factor of 10.
3. Direct or immediate hazards to life and limb due to radiated or conducted EMI do not exist in neurophysiological areas of hospitals.
4. The neurophysiological equipment demonstrates its susceptibility in such a way that it is immediately recognizable. This reduces the problem from a possible hazard due to wrong diagnosis to that of a nuisance requiring nothing more than equipment rearrangement or procedural changes.
5. The shielding effectiveness to be gained by installing conventional shielding for EEG equipment operation (less than 200 Hz) is absolutely minimal.
6. The shielding effectiveness to be gained by installing conventional shielding for electromyograph equipment operation is significant due to the wide frequency range (30 to 10^4 hertz).
7. The lack of low frequency powerline filters is a definite drawback in efforts to shield all neurophysiological equipment.

RECOMMENDATIONS

1. Neurophysiological clinics should be located as far away as possible from known EMI sources, such as overhead powerlines, vehicle roads and parking areas, fluorescent lights, and maintenance shops or equipment.
2. In those hospitals where electromyograph equipment operation is planned, a conventional copper screen shielded room should be provided.
3. Hospital personnel should be instructed to minimize the loop area of the patient's conductor leads for all clinical neurophysiological test setups as a standard procedure.
4. Hospital personnel responsible for purchasing Navy medical equipment should specify that the sensitive medical equipment undergo EMI susceptibility testing by the manufacturer.

ACKNOWLEDGMENT

The author wishes to acknowledge the officers and men of the Neurology Department of the Bethesda Naval Medical Center for their assistance and cooperation during the test period. In addition, the assistance of Mr. J. Franchi of CEL is gratefully acknowledged.

REFERENCES

1. Civil Engineering Laboratory. Technical Note N-1401: Electromagnetic shielding requirements within Naval hospitals, by James L. Brooks. Port Hueneme, Calif., Sep 1975.
2. L. A. Geddes and L. E. Baker. Principles of applied biomedical instrumentation. New York, N.Y., John Wiley and Sons, 1975.
3. Tri-Service Specification MIL-STD-461/462/463: Electromagnetic interference characteristics. Nov 1968.
4. Air Force Systems Command. Contract Report: RFI attenuating materials and structures, by R. B. Cowdell, R. A. Hupp and J. N. O'Leary, Genistron Division, Genisco Technology Corp, Compton, Calif., 1964. (Contract No. F33615-68-C-1206, project 8174)
5. Erik A. Lindgren. Contemporary RF enclosures, by Erik A. Lindgen & Associates, Inc. Chicago, Ill., 1967.

Table 1. Comparison of Shielding Techniques

Type of Shielding	Installation Costs \$/ft ²	100Hz Shielding Effectiveness	Comments
Continuously welded steel with pneumatically operated door	60	0 db M 120 db E	Best performance at R. F. low maintenance
Overlapped steel sheets (not welded) with mechanical door	45	0 db M 100 db E	Good performance at R. F. normal maintenance
Double, electrically isolated copper with mechanical door	40	20 db M 100 db E	Good performance maintenance problems with doors
Solid copper room	25	10 db M 100 db E	Standard design
Copper screen	15	10 db M 60 db E	Standard design
Flame spray	10	10 db M 60 db E	Non-standard, high maintenance costs + door problems
Conductive paint	6	0 db M 30 db E	Non-standard, high maintenance costs + door problems

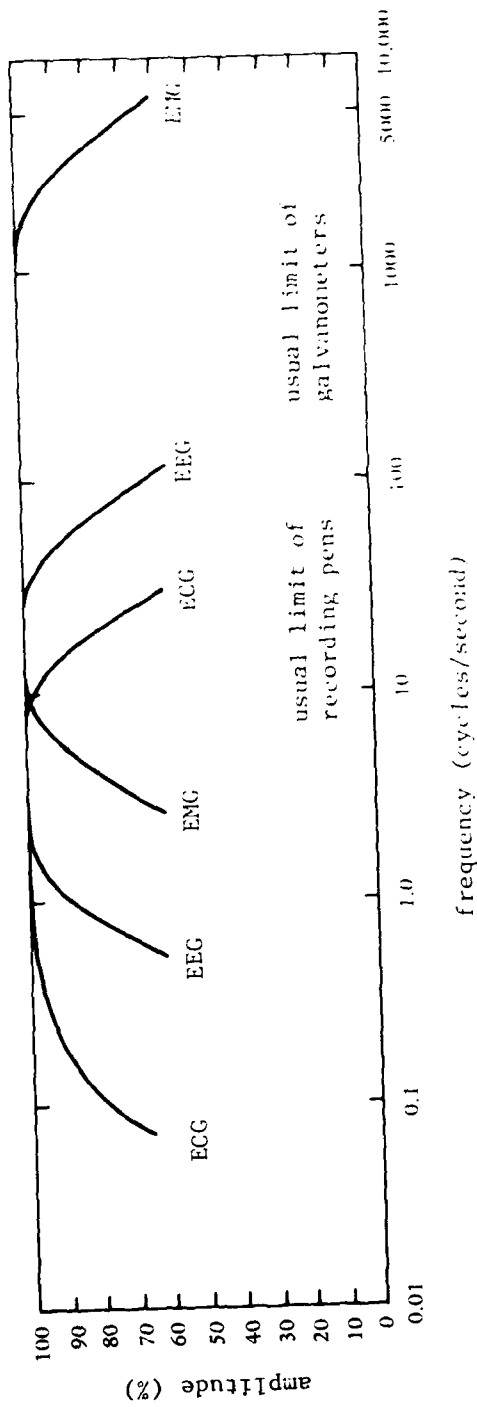

Figure 1. Frequency spectrum of clinically recorded bioelectric events.

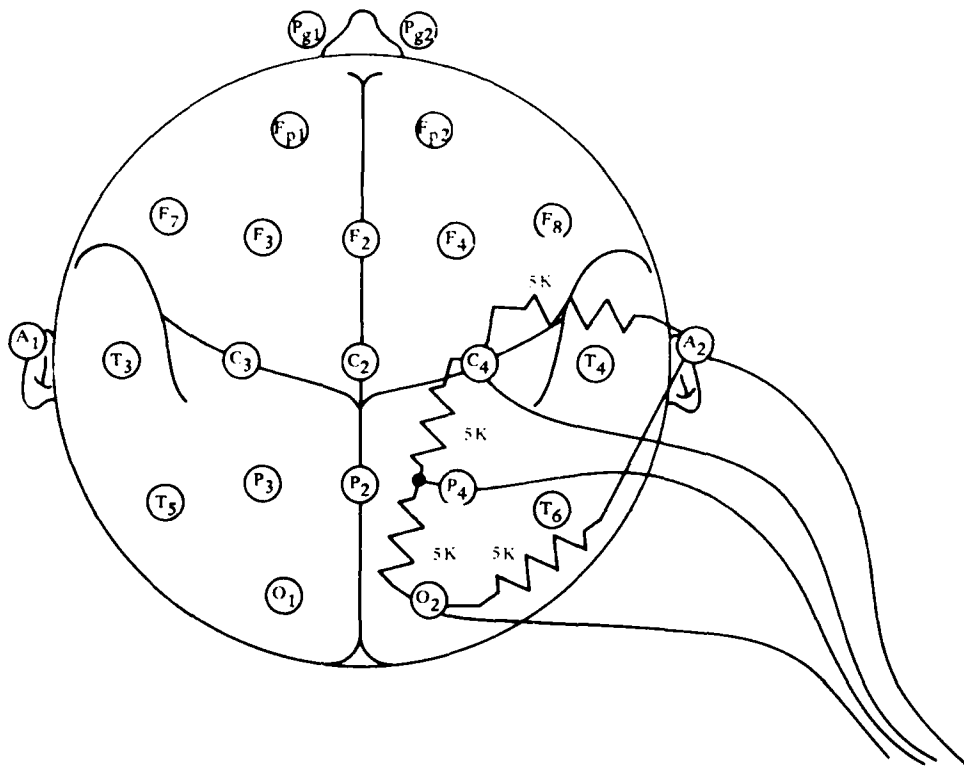

Figure 2. Patient/machine interface simulation using a life-size styrofoam ball for the head and resistors between connection points for skin resistivity.

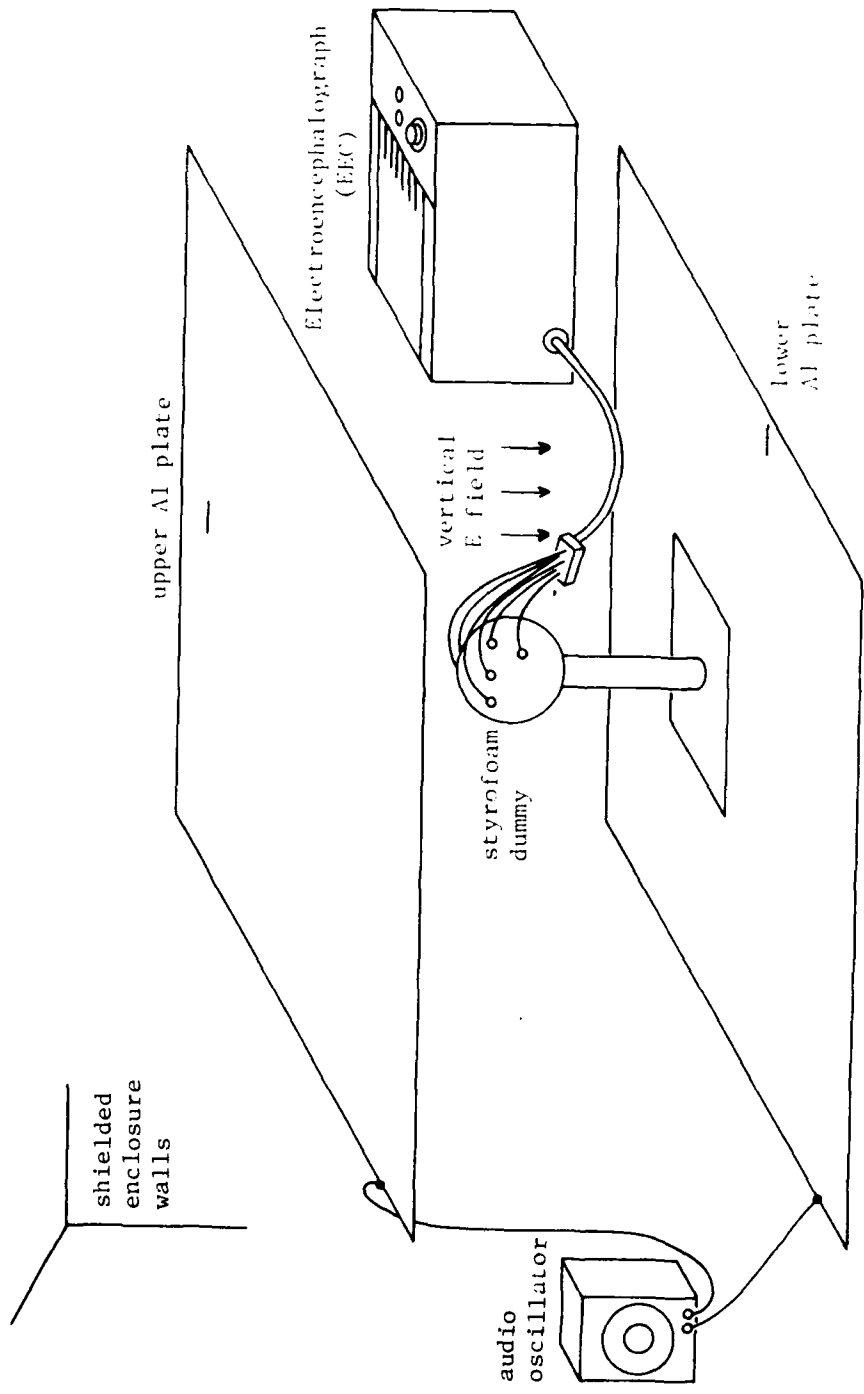

Figure 3. Test setup for electric field susceptibility of EEG machine/patient simulation.

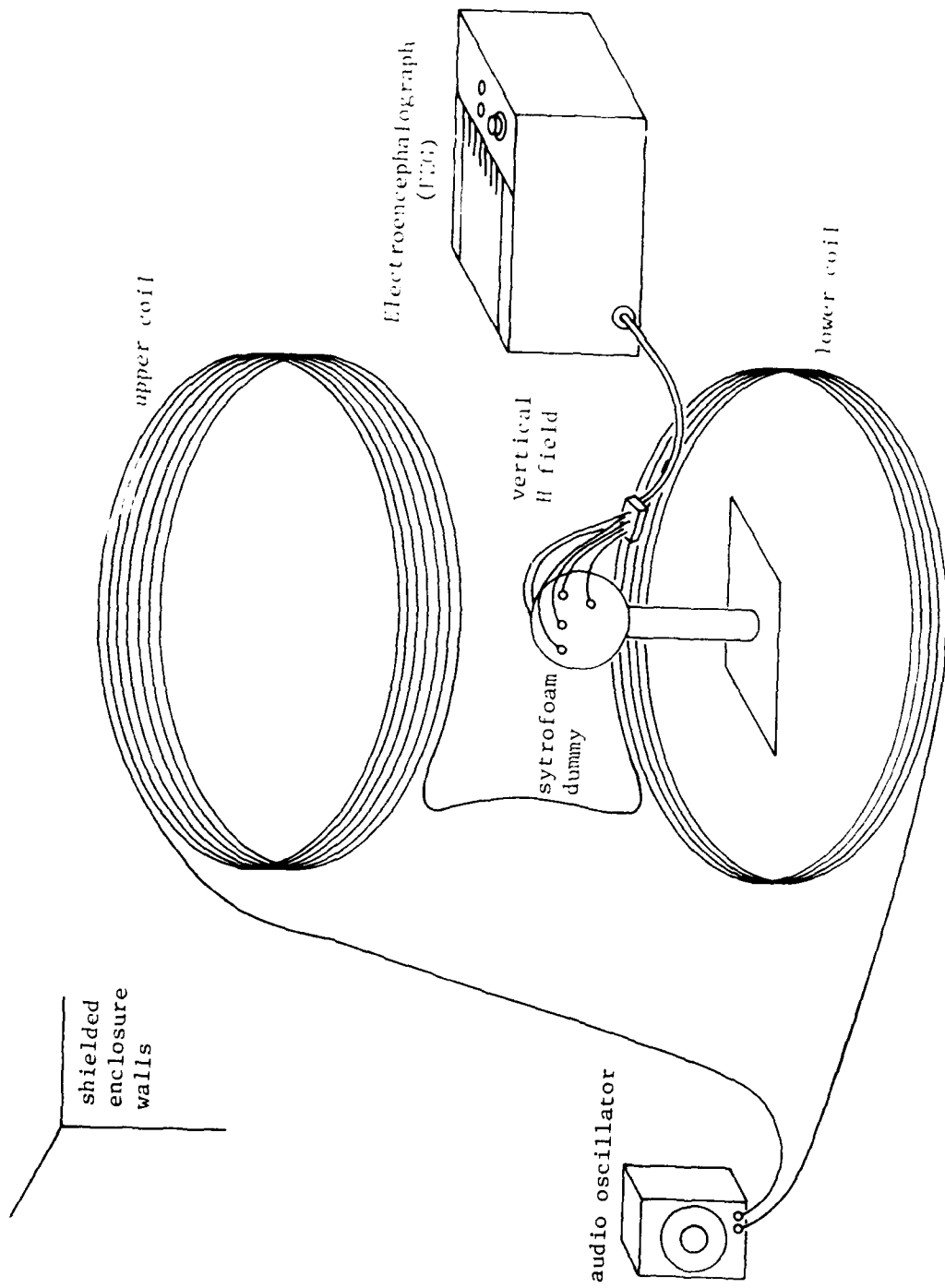

Figure 4. Test setup for magnetic field susceptibility of EEG machine/patient simulation.

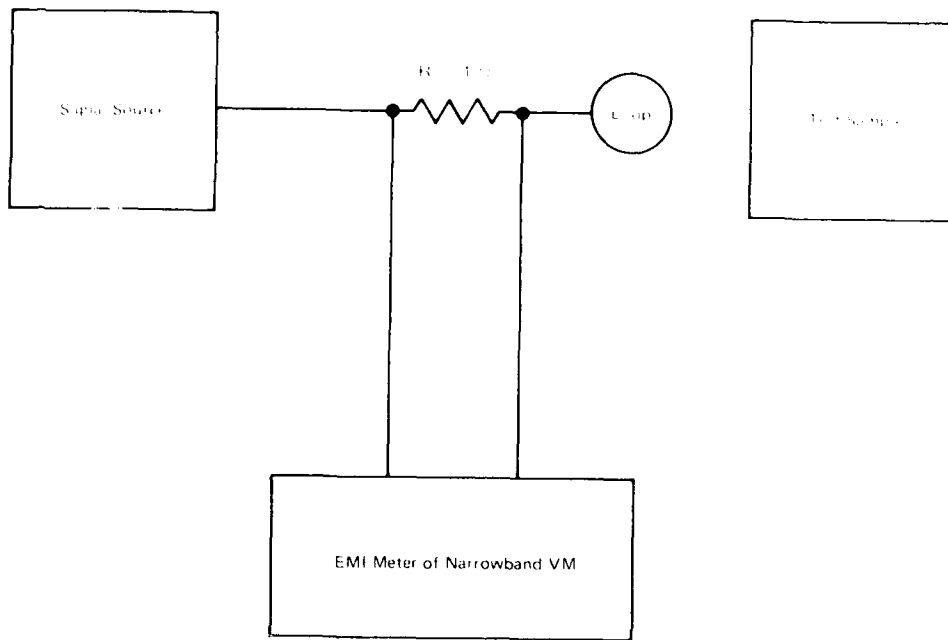
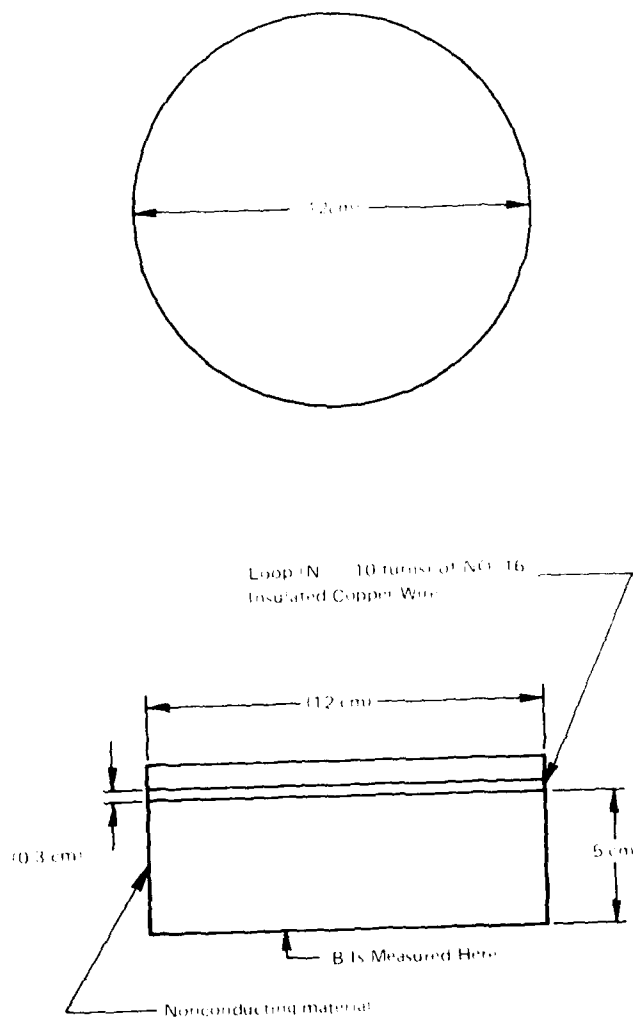

Figure 5. Radiated susceptibility, 1 Hz to 10 kHz, magnetic field.



- Note: (a) $B = 5 \times 10^5$ tesla amp at 5 cm from wire turns
 (b) Loop self resonant frequency shall be greater than 100 MHz
 $1 \text{ tesla} = 1 \text{ Weber/M}^2 = 10^4 \text{ gauss}$

Figure 6. Loop used for radiating magnetic fields.

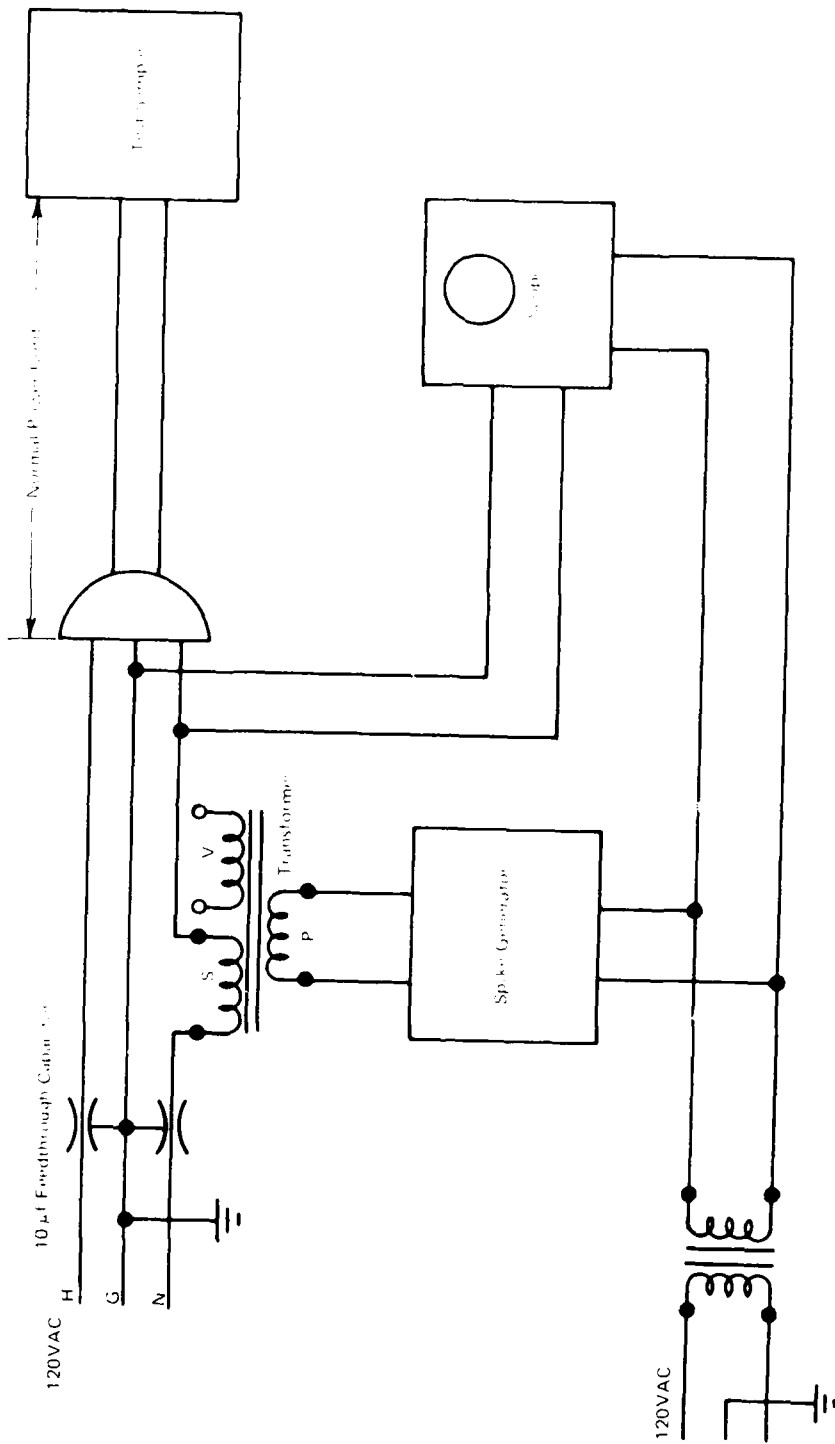
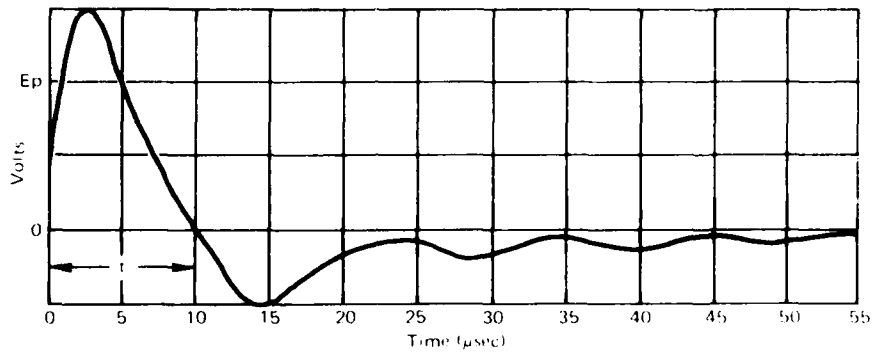

Figure 7. Test setup for conducted susceptibility, applied on AC power leads.



Note: (a) E_p Two times line voltage or 100 volts, whichever is less.
 (b) $t = 10 \mu\text{sec}$

Figure 8. Applied spike voltage for conducted susceptibility, spike, tests.

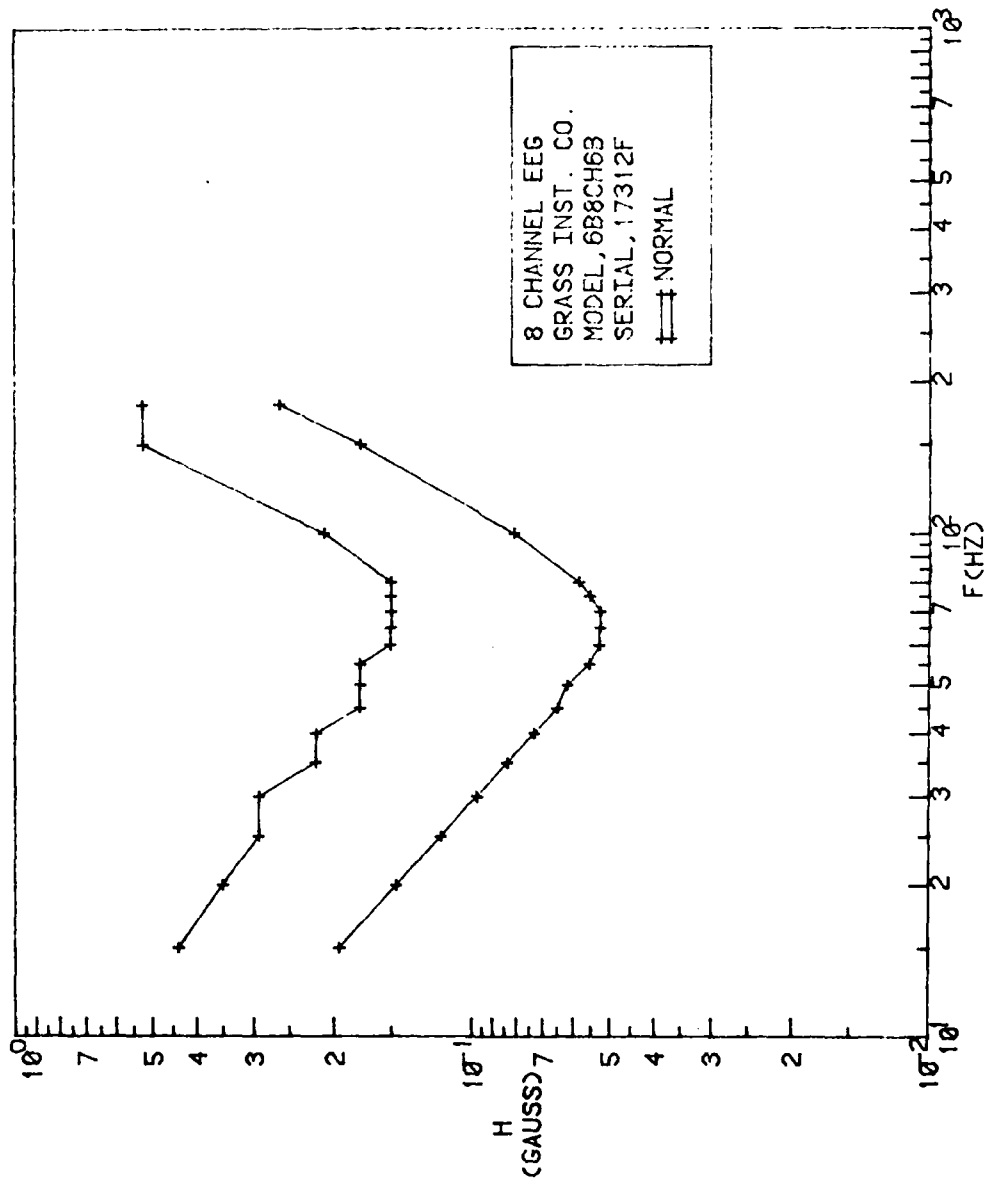

Figure 9. Magnetic field susceptibility of 8-channel EEG, model 6B8CH6B.

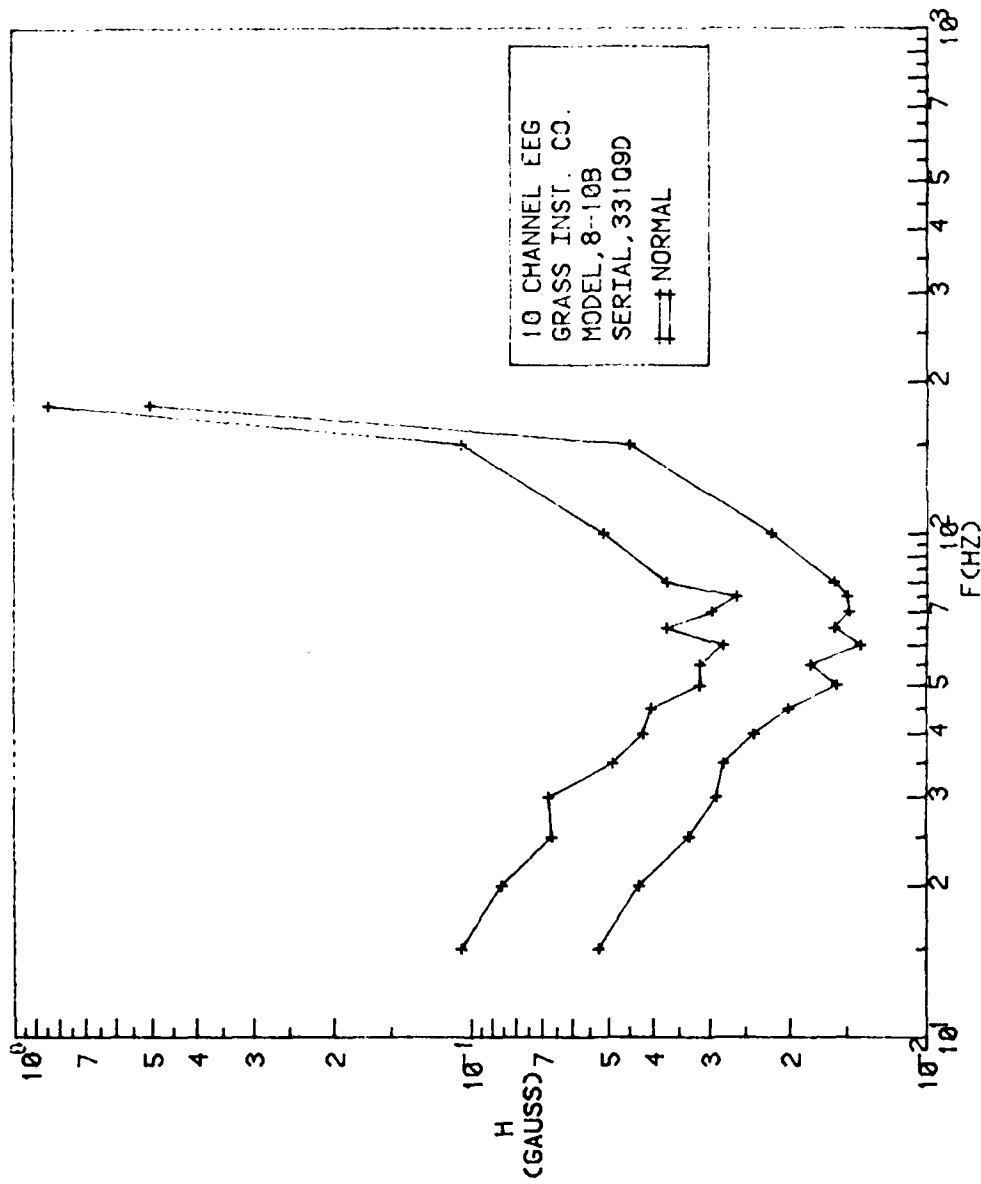

Figure 10. Magnetic field susceptibility of 10-channel EEG, model 8-1013.

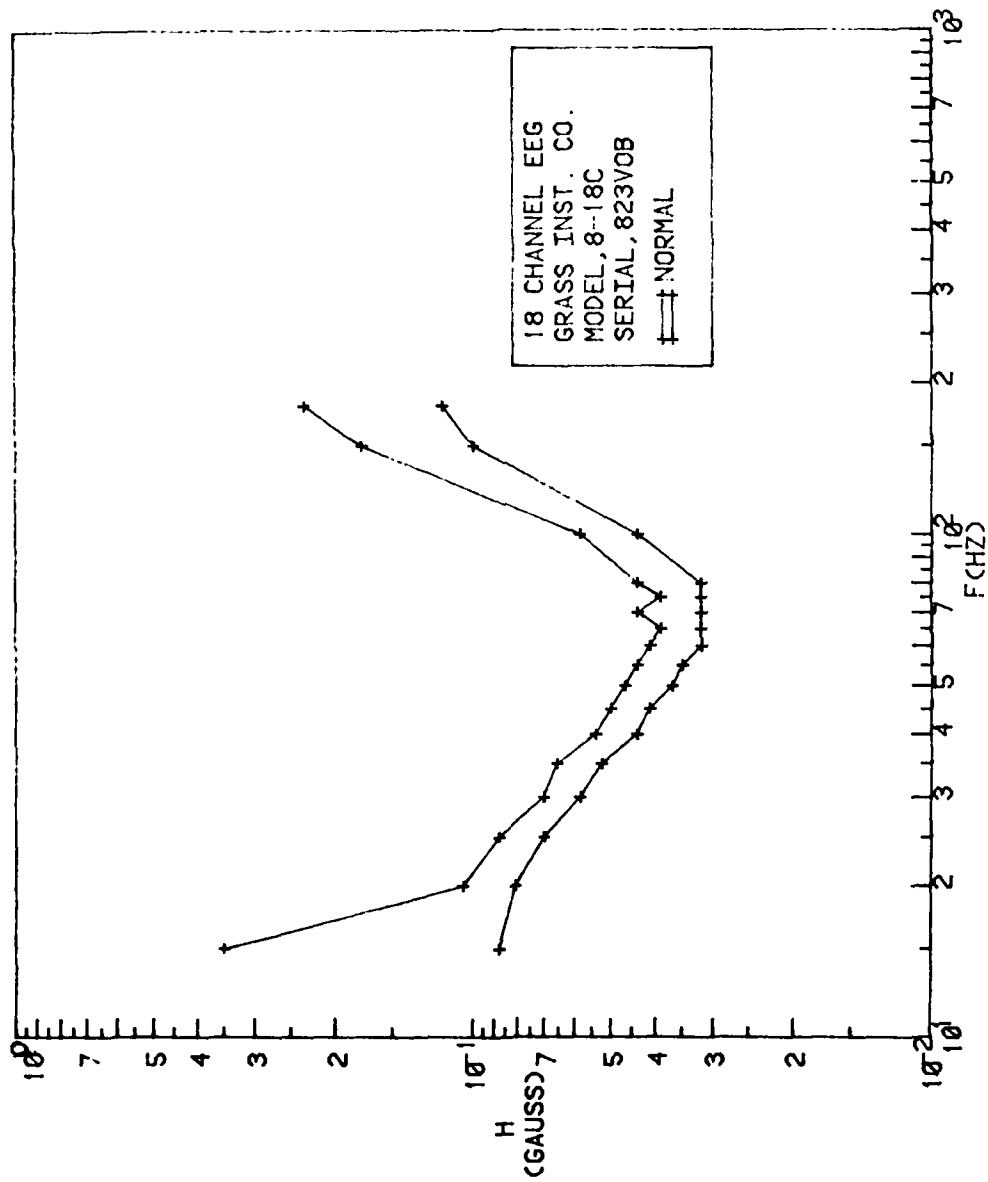

Figure 11. Magnetic field susceptibility of 18-channel EEG, model 8-18C.

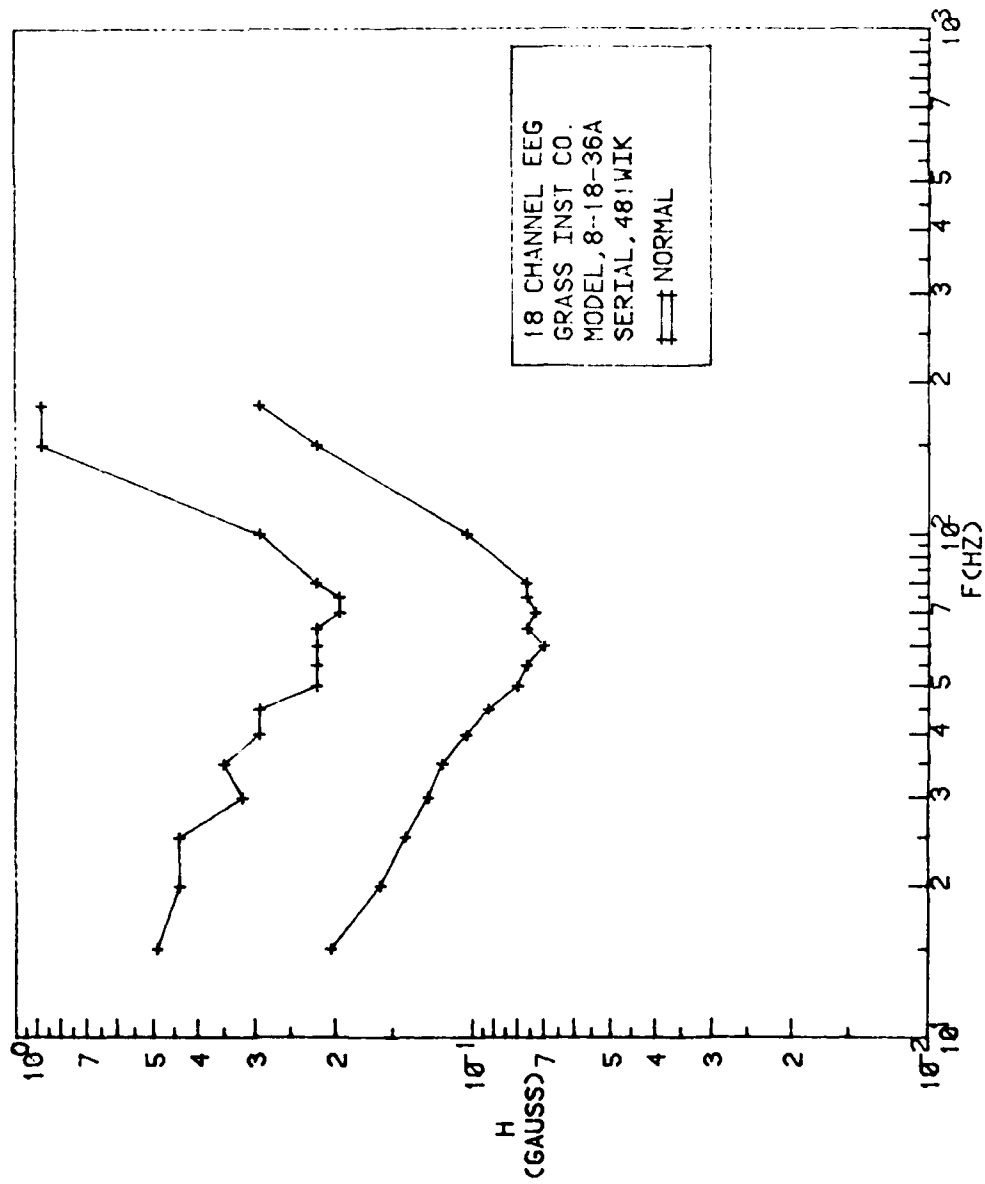

Figure 12. Magnetic field susceptibility of 18-channel EEG,
 model 8-18-36A.

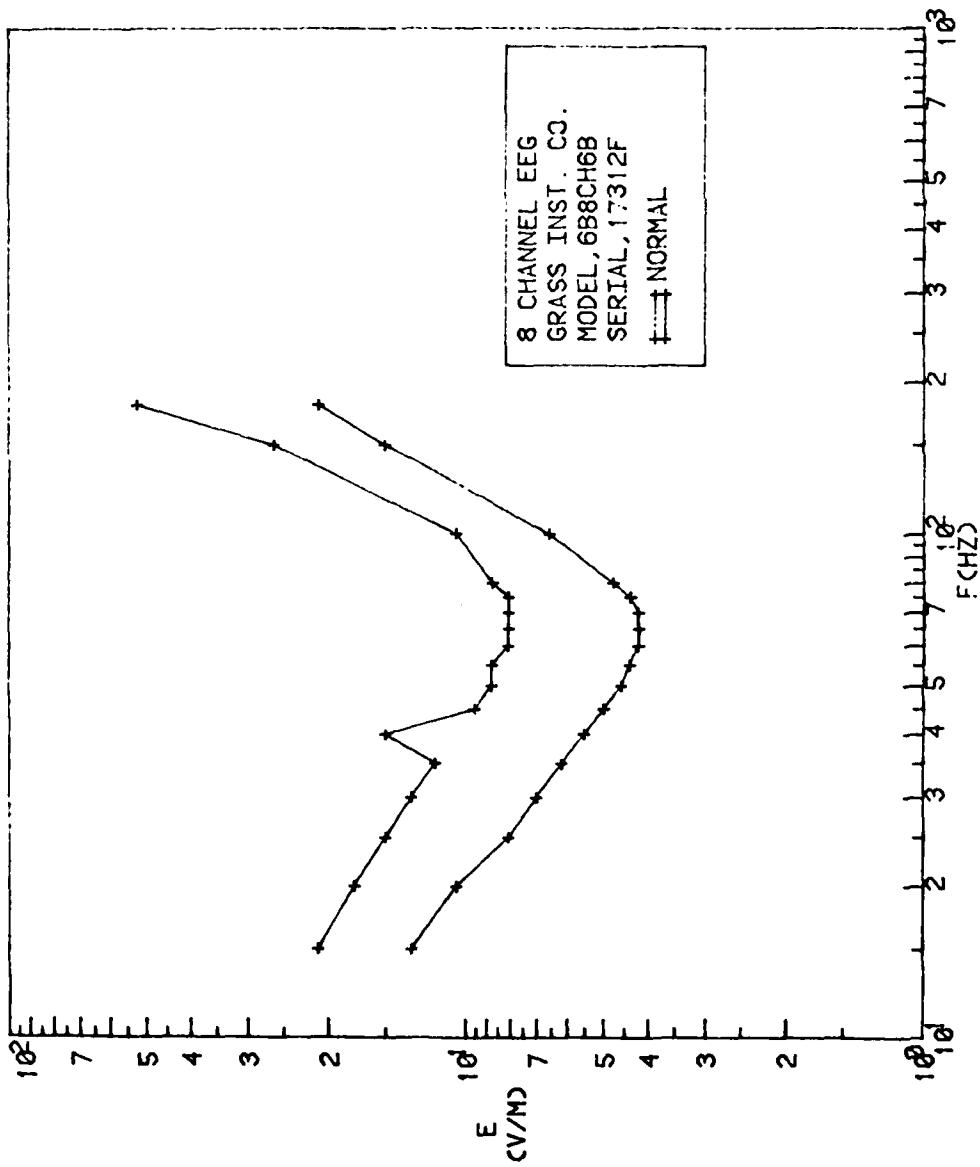

Figure 13. Electric field susceptibility of 8-channel EEG, model 6138Ch6B.

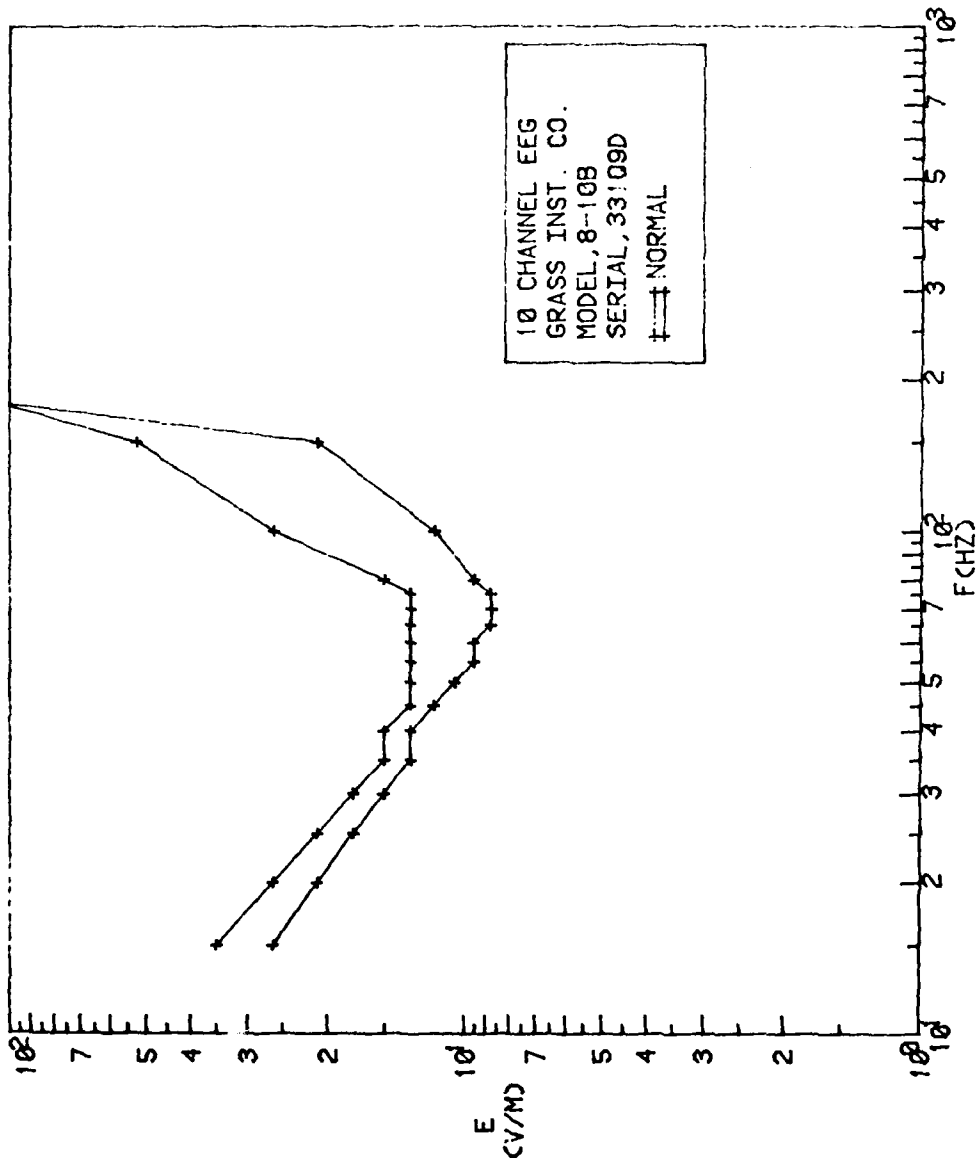

Figure 14. Electric field susceptibility of 10-channel EEG, model 8-1013.

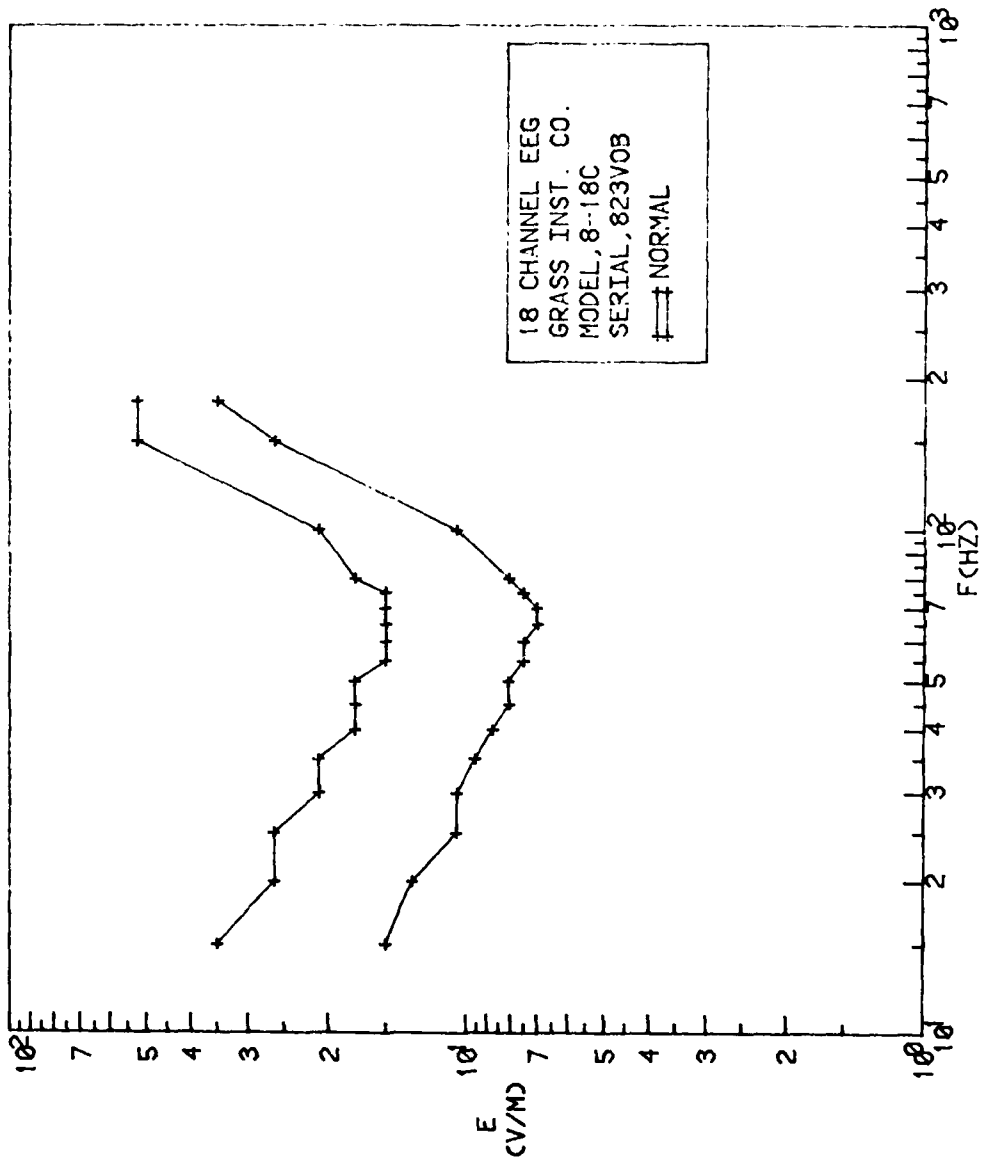

Figure 15. Electric field susceptibility of 18-channel EEG, model 8-18C.

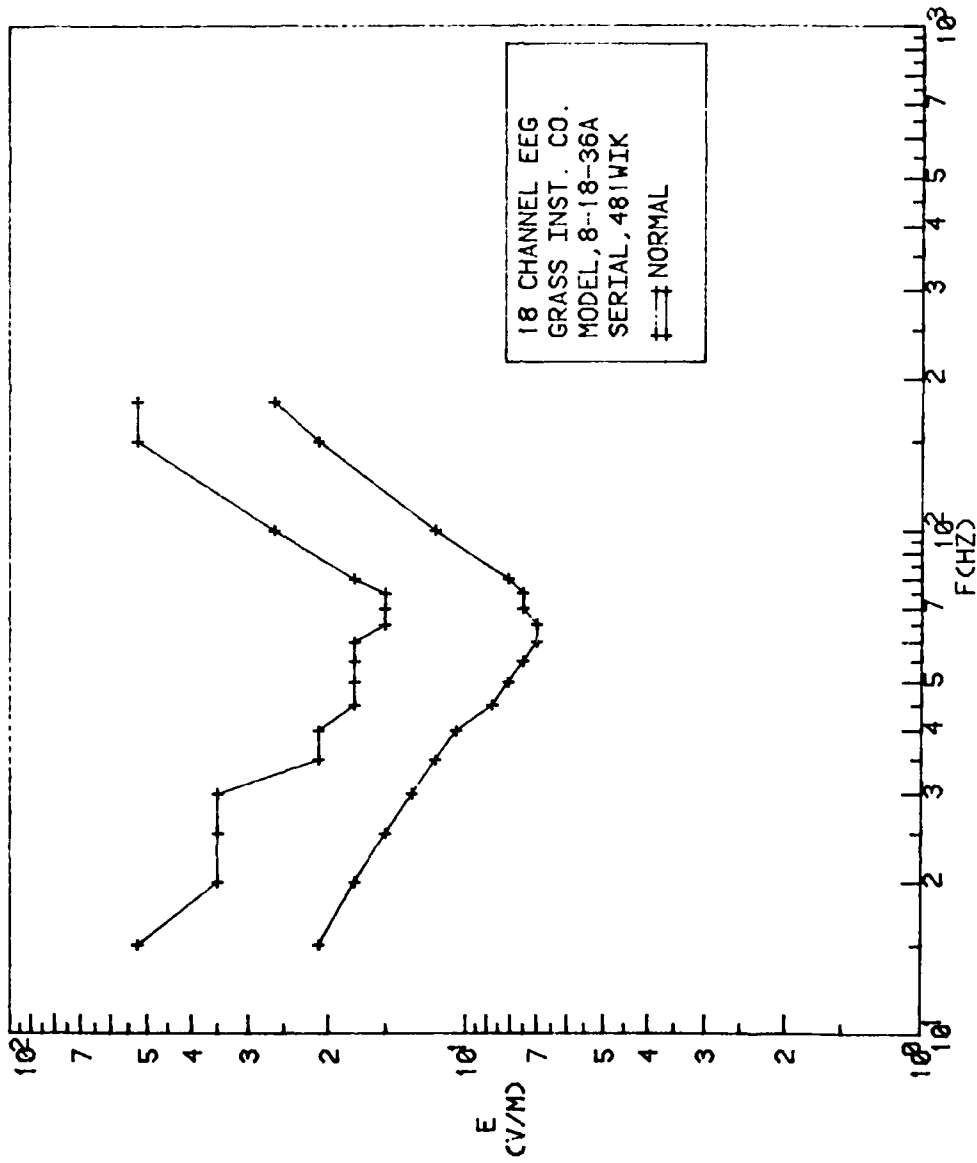
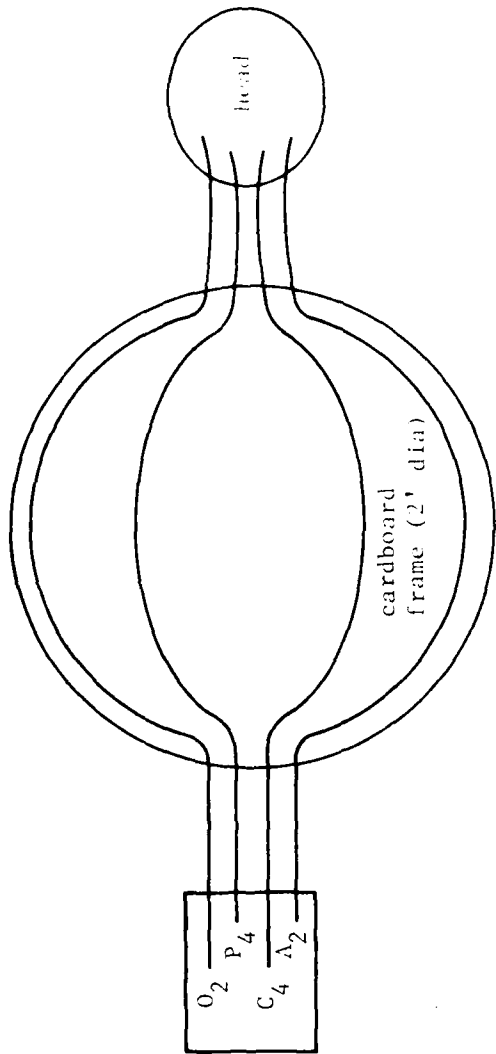
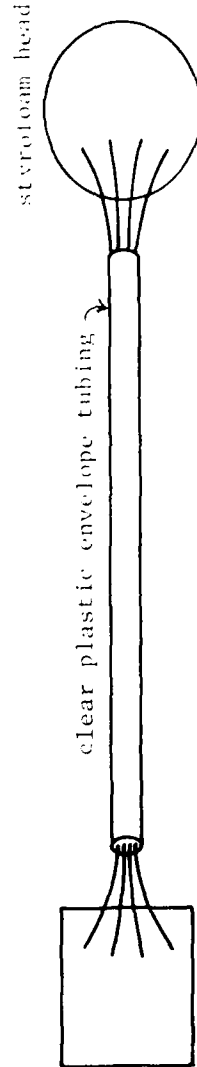

Figure 16. Electric field susceptibility of 18-channel EEG, model 8-18-36A.



(a) Conductors widely separated (maximum loop area).



(b) Conductor leads in close proximity (minimum loop area).

Figure 17. Test setup for investigation of the sensitivity factors associated with the conductor orientation and effective loop area.

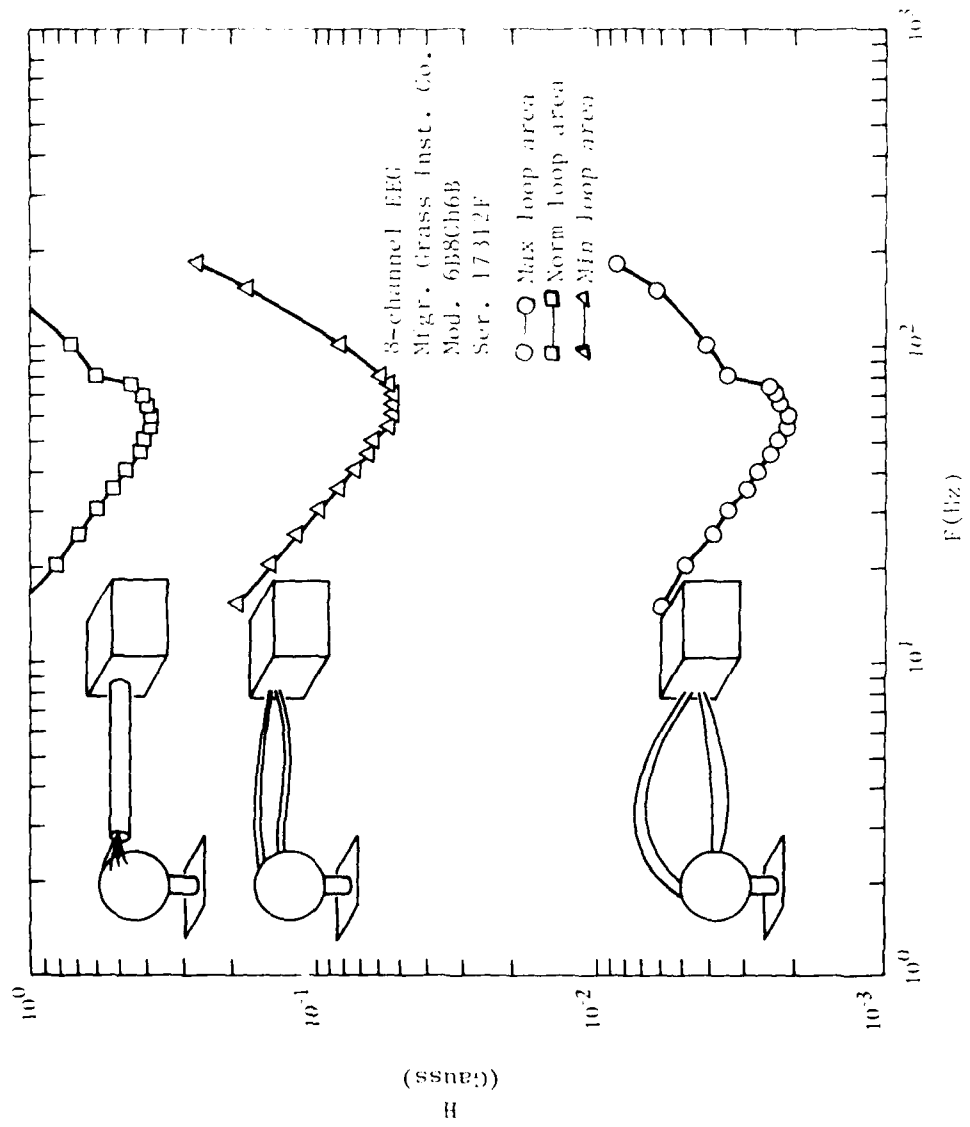

Figure 18. Variation of susceptibility of EC machines to magnetic fields for various conductor loop areas.

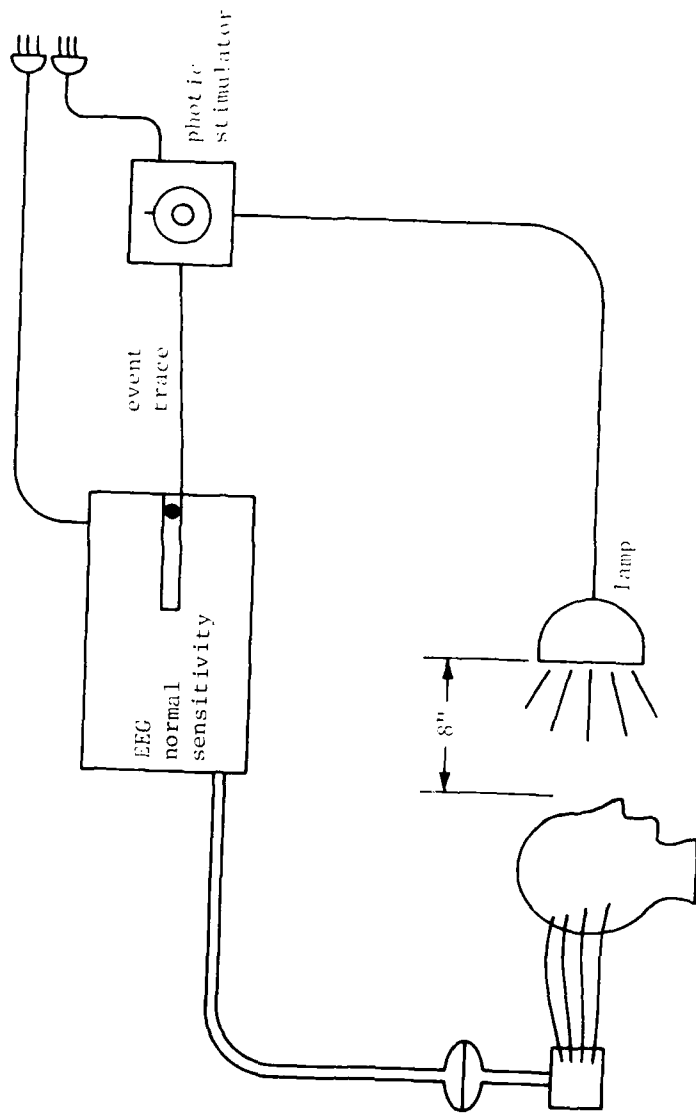
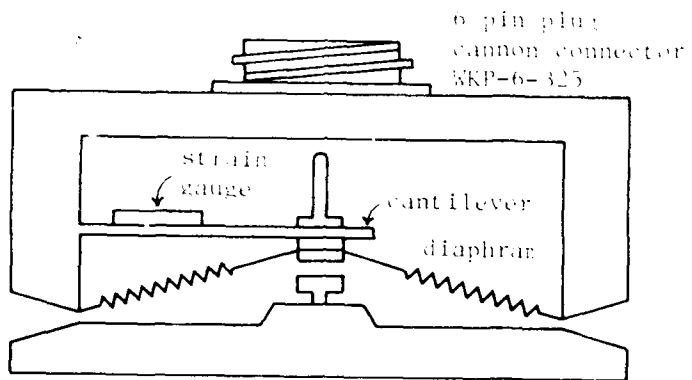
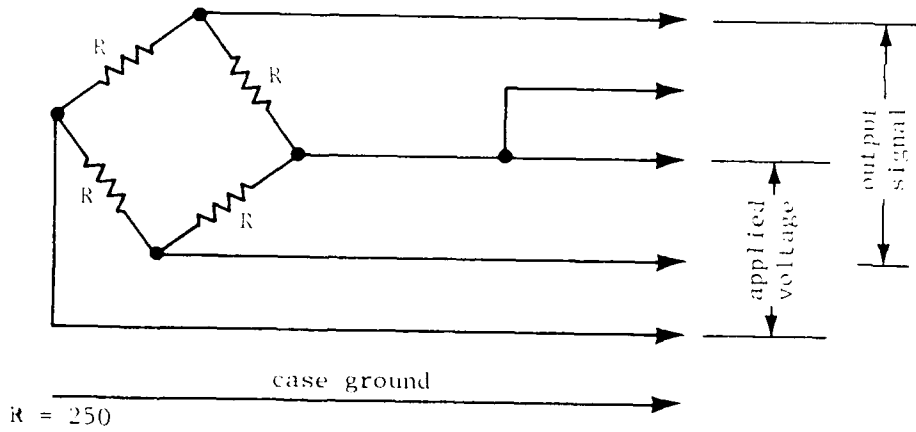

Figure 19. Photic stimulator test setup.



(a) Mechanical details.



$R = 250$

(b) Electrical details.

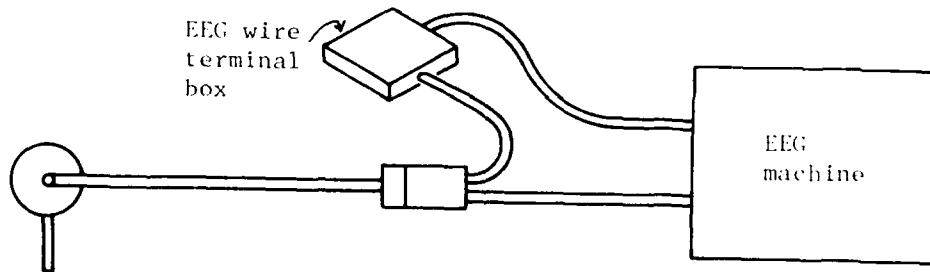

(c) Connection diagram.

Figure 20. Details of Plethysmograph Model PT5.

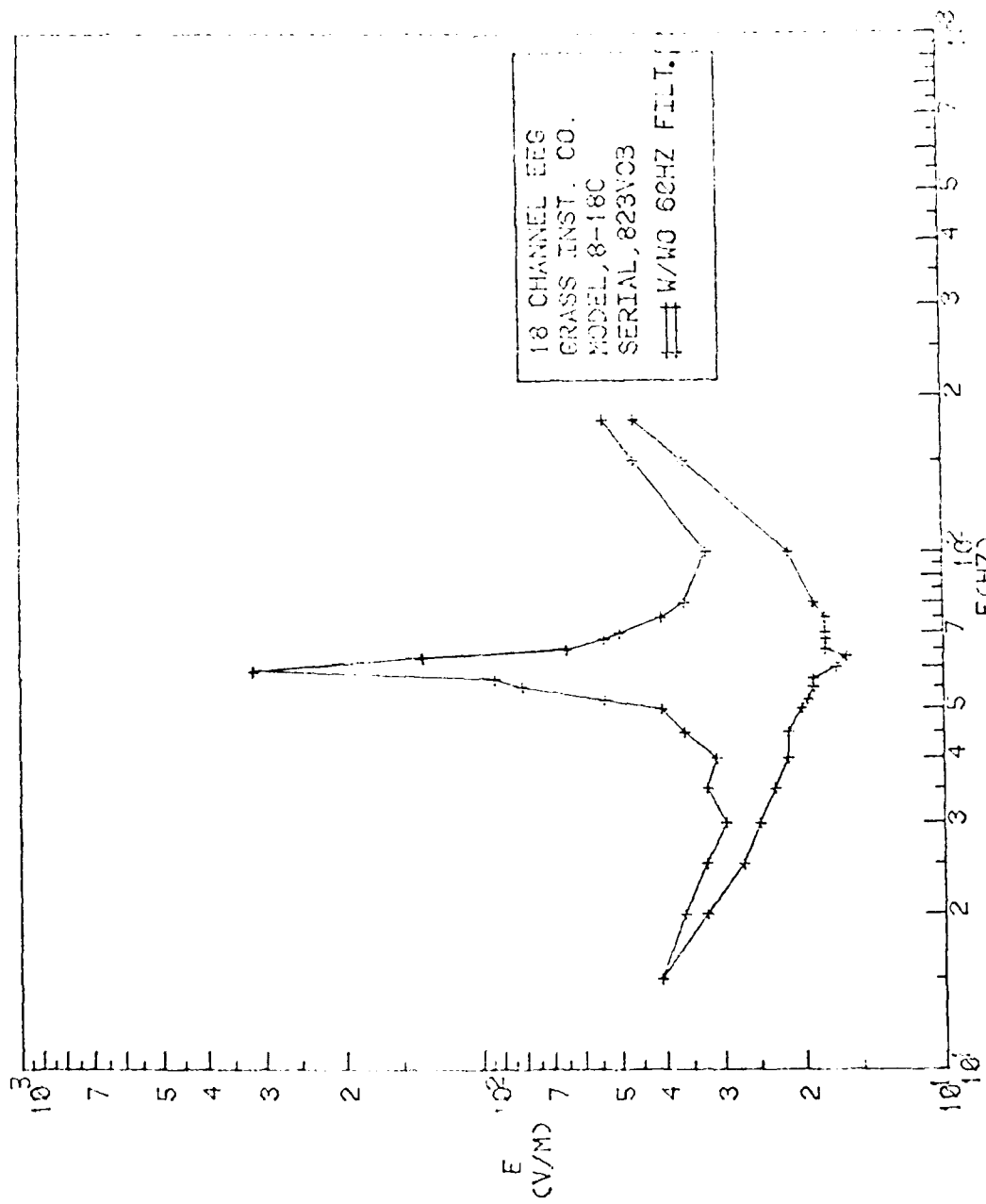

Figure 21. Electric field susceptibility of EEG machine with and without 60-Hz filter.

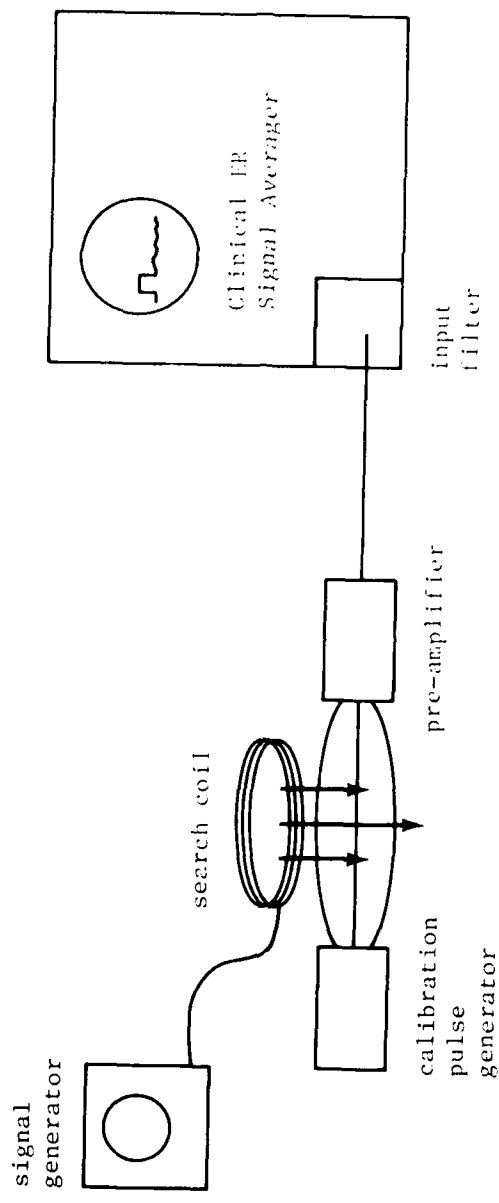
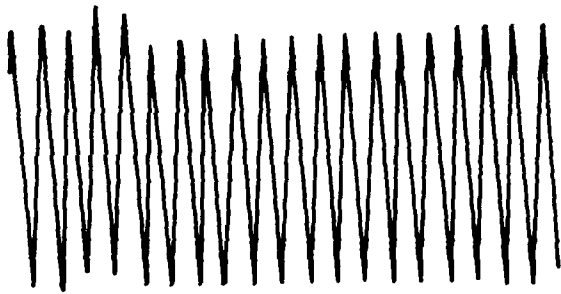
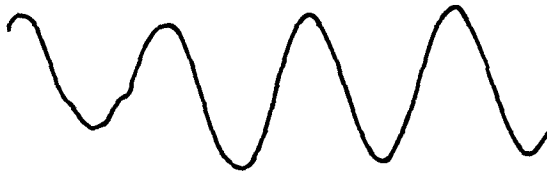

Figure 22. Susceptibility test setup for response of Clinical ER Signal Averager to magnetic field search coil.



(a) 0.5.V calibration pulse with synchronized 97 hertz interference.



(b) 0.5.V calibration pulse with synchronized 19 hertz interference.



(c) 0.5.V calibration pulse with unsynchronized interference.

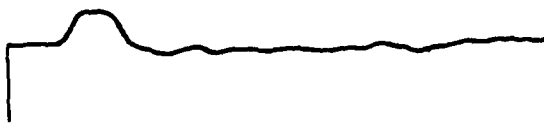

(d) 0.5.V calibration pulse.

Figure 23. Susceptibility traces of clinical, evoked response signal averager system.

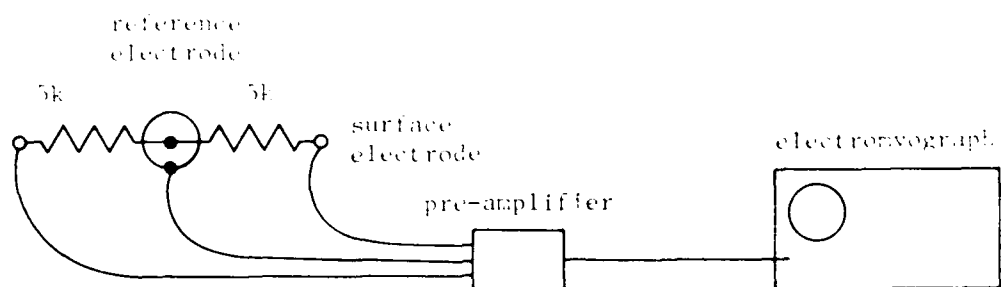

(a) Using surface electrodes.

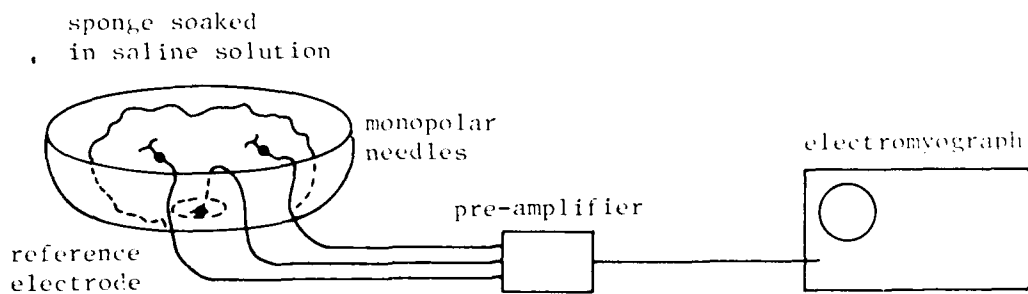

(b) Using monopolar needles.

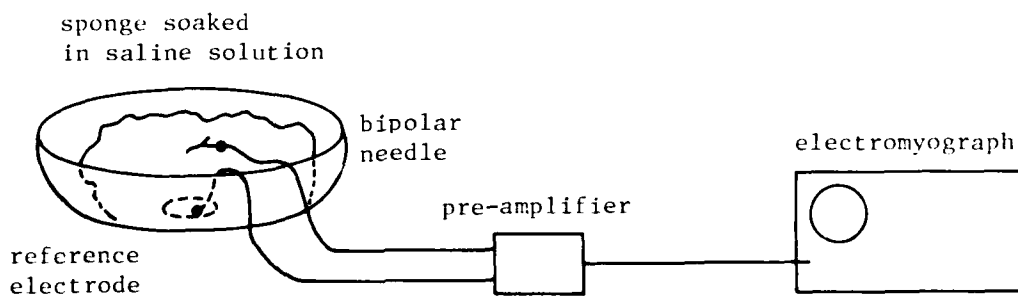

(c) Using bipolar needles.

Figure 24. Test setup for radiated field susceptibility of electromyograph.

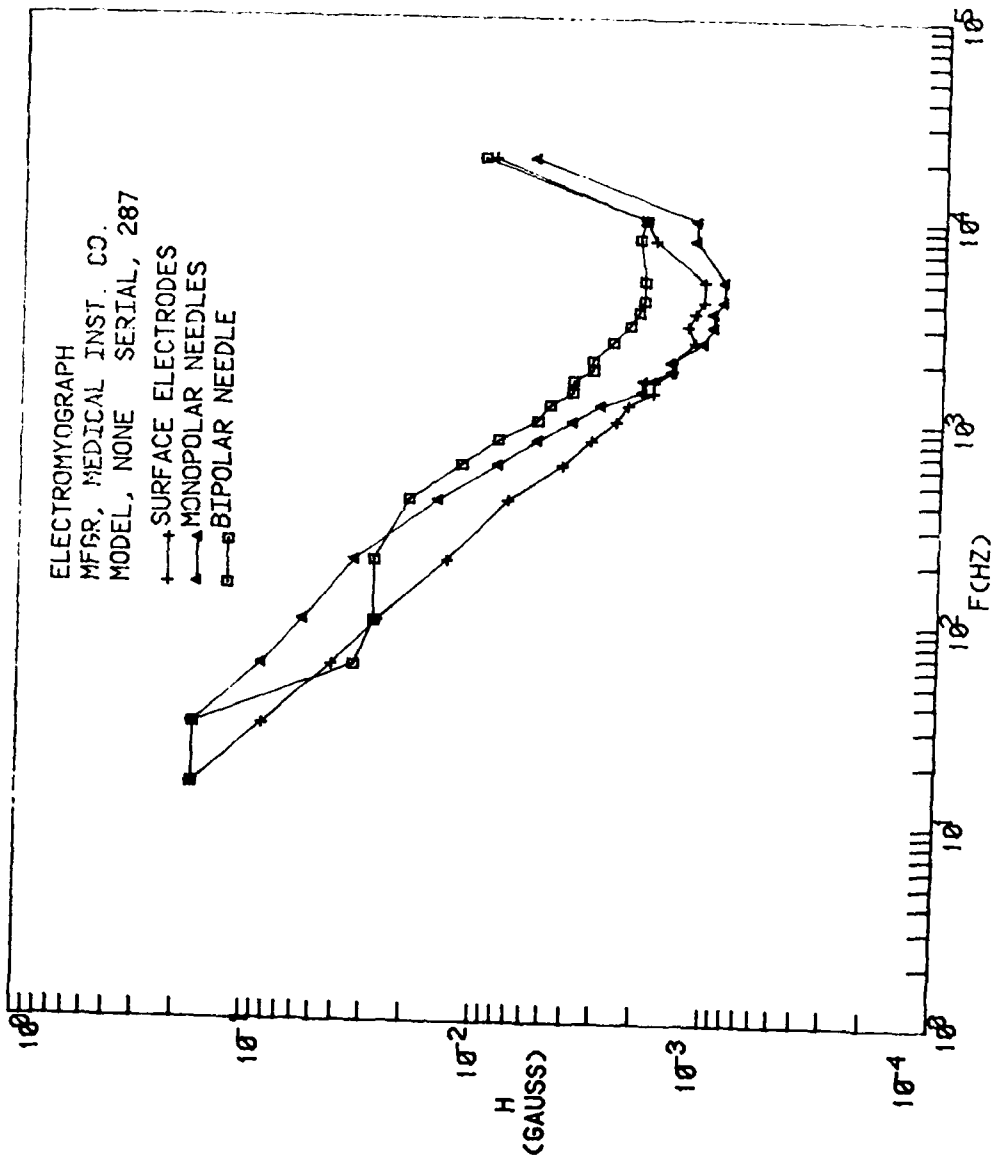

Figure 25. Magnetic field susceptibility of electromyograph built by Medical Instrument Co.

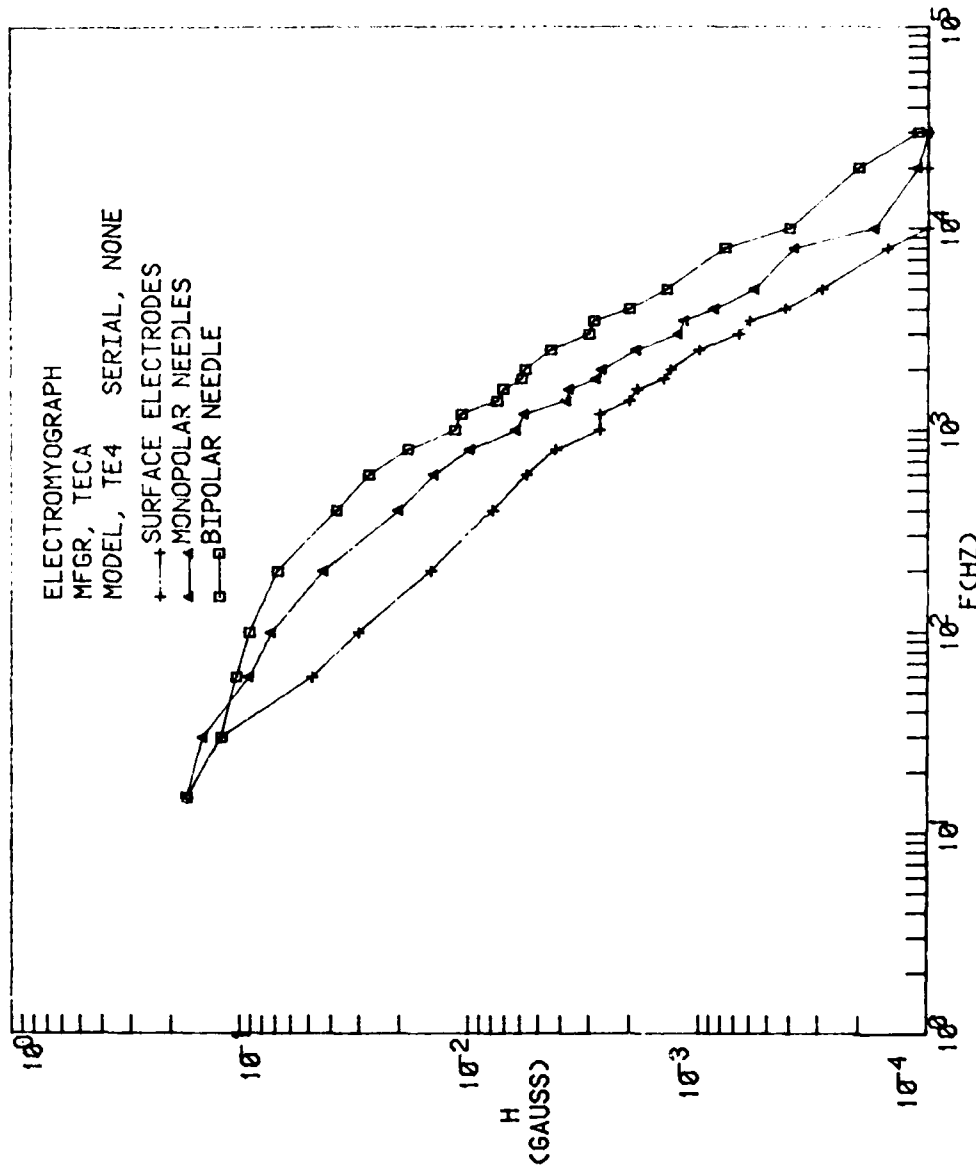

Figure 26. Magnetic field susceptibility for electromyograph built by TECA.

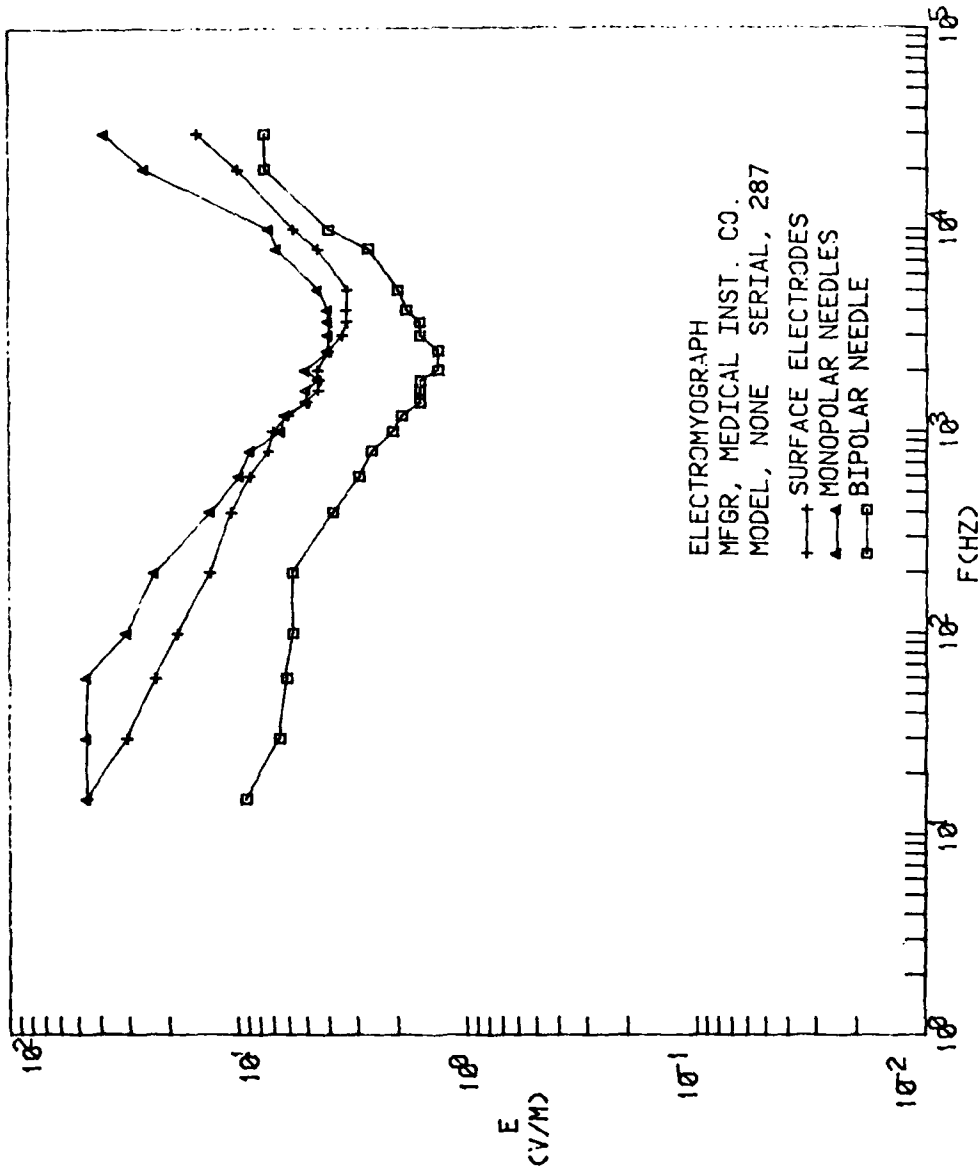

Figure 27. Electric field susceptibility of electromyograph built by Medical Instrument Co.

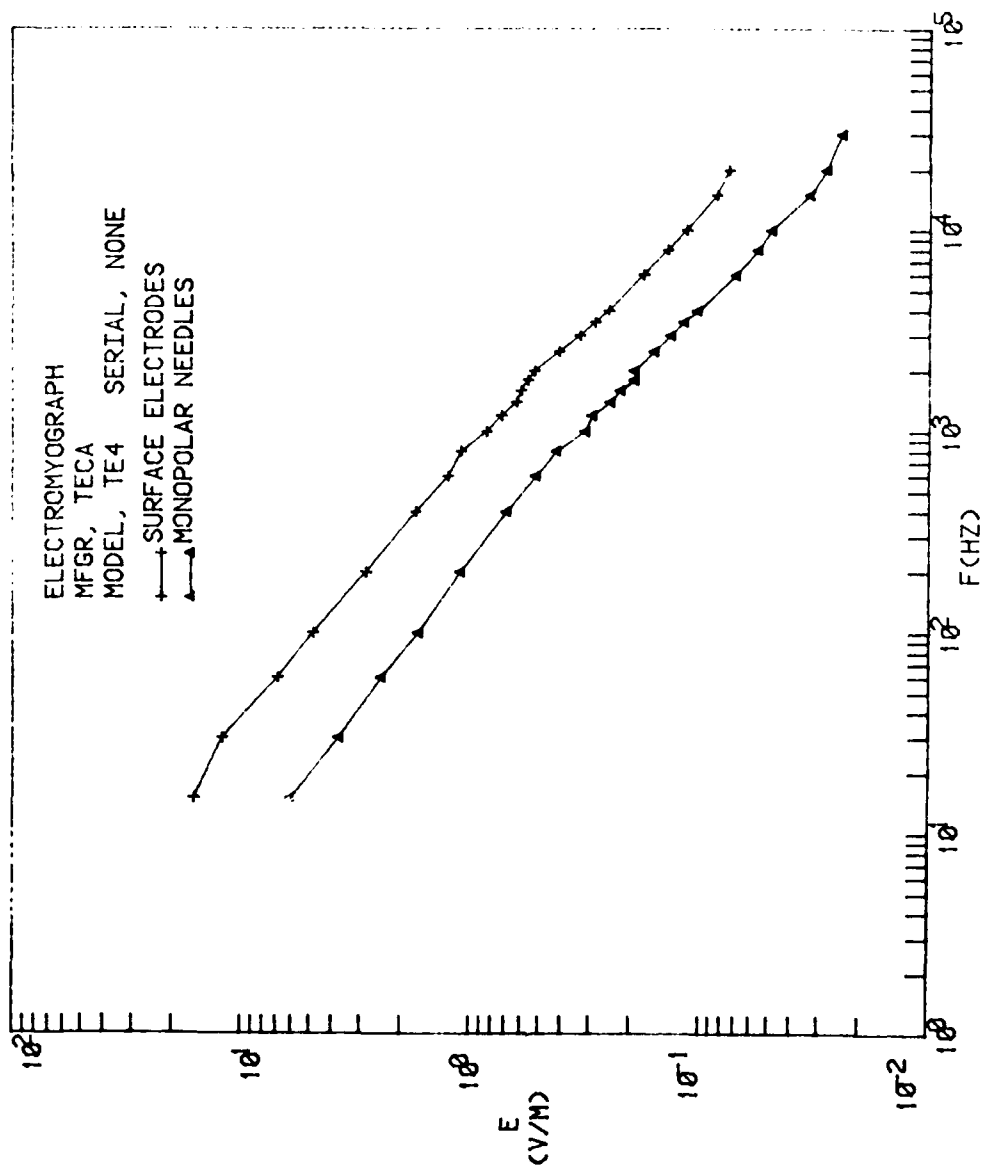

Figure 25. Electric field susceptibility of electromyograph built by TECA.

DISTRIBUTION LIST

AFB AF Tech Office (Mgt & Ops) Tyndall FL; AFCEC XR Tyndall FL; CFSCH Wright Patterson Hq Ft. Belvoir VA
 CDR R. E. Fisher, Langley AFB VA; HQAFESC DE MM Tyndall AFB FL; MAC DE L. Col. P. Thompson
 S. Col. H. SAMSON MINND, Norton AFB CA; State Library, O'Hair NE
 ARMY BMDSC RE (H. McClellan) Huntsville AL; DAEN CWF M. J. U. C. Drawings, Washington DC
 DAEN EE L. E. Ronani, Washington DC; DAEN MPU, Washington DC; Tech. Ref. Div., Fort H. Cochrane AZ
 ARMY COE, Philadelphia Dist. (LIBRARY) Philadelphia, PA
 ARMY CORPS OF ENGINEERS MRD-Eng. Div., Omaha NE; Seattle Dist. Library, Seattle WA
 ARMY ENVIRON. HYGIENE AGENCY, Water Qual. Div. (Doner), Aberdeen Proving Ground MD
 ASSISTANT SECRETARY OF THE NAVY, Spec. Assist. Energy (Leonard), Washington DC
 BUMED Field Med. Sys. School, Camp Pendleton, CA
 BUREAU OF RECTIFICATION Code 1512 (C. Selander) Denver CO
 CINCLANT Civil Engr. Supp. Plans, Off. Norfolk VA
 CINCPAC Fac. Engring Div (J44) Makalapa, HI
 CNO Code NOP-964, Washington DC
 COMBIFACT, OKINAWA PWO, Kadena, Okinawa
 COMNAVMAINTANAS Code N4, Guam
 COMOCEANSSYPAC SCE, Pearl Harbor HI
 DEFENSE DOCUMENTATION CTR, Alexandria, VA
 DOE, Dr. Cohen, ECMWF ULI, Washington DC
 DIRNSRDC Code 4111 (R. Grenich), Bethesda MD; Code 42, Bethesda MD
 ITCOMBATIRACINLANI PWO, Virginia Bch VA
 IMLANTCEC Off., Norfolk VA
 KWAJALEIN MISRAN BMDSC-RKI-C
 MARINE CORPS BASE, Camp Pendleton CA 92055; Code 43-260, Camp Lejeune NC; M & R Division, Camp Lejeune
 NC; PWO Camp Lejeune NC; PWO, Camp S. D. Butler, Kawasaki Japan
 MARINE CORPS HQS Code IFF-2, Washington DC
 MCAS Facil. Engr. Div., Cherry Point NC; CO, Kaneohe Bay HI; Code PWF, Kaneohe Bay HI; Code S4, Quantico
 VA; PWD, Dir. Maint. Control Div., Iwakuni Japan; PWO Kaneohe Bay HI; PWO, Yuma AZ
 MCRD PWO, San Diego Ca
 NAD Engr. Dir. Hawthorne, NV
 NAF PWD- Engr Div., Atsugi, Japan; PWO Sigonella Sicily; PWO, Atsugi Japan
 NAF OINC, San Diego, CA
 NARI Code 100, Cherry Point, NC
 NAS CO, Guantanamo Bay Cuba; Code 114, Alameda CA; Code 183 (Fac. Plan BR MGR), Code 187, Jacksonville FL;
 Code 18700, Brunswick ME; Code 18U (ENS P.J. Hickey), Corpus Christi TX; Code 6234 (G. Trask), Point Mugu
 CA; Code 70, Atlanta, Marietta GA; Dir. Util. Div., Bermuda; ENS Buchholz, Pensacola, FL; Lakehurst, NJ; PW
 (J. Maguire), Corpus Christi TX; PWD Maint. Div., New Orleans, Belle Chasse LA; PWD, Maintenance Control
 Div., Bermuda; PWD, Willow Grove PA; PWO Belle Chasse, LA; PWO Chase Field Beeville, TX; PWO Key West
 FL; PWO Whiting Fld, Milton FL; PWO, Dallas TX; PWO, Glenview IL; PWO, Kingsville TX; PWO, Millington
 TN; PWO, Miramar, San Diego CA; PWO, Moffett Field CA; SCE Lant Fleet Norfolk, VA; SCE Norfolk, VA;
 Security Offr., Alameda CA
 NATL RESEARCH COUNCIL, Naval Studies Board, Washington DC
 NA1NAVMEDECEN PWO Bethesda, MD
 NAVAC1 PWO, London UK
 NAVAFROSPREGMEDECEN SCE, Pensacola FL
 NAVAVIONICFAC PWD Deputy Dir. D 701, Indianapolis, IN
 NAVCOASTSYSCTR Code 423 (D. Good), Panama City FL; Code 713 (J. Quirk) Panama City, FL; Library Panama
 City, FL
 NAVCOMMAREAMSTRSTA Code W-602, Honolulu, Wahiawa HI; PWO, Norfolk VA; PWO, Wahiawa HI; SCE
 Unit I, Naples Italy
 NAVCOMMSTA CO (61E) Puerto Rico; CO, San Miguel, R. P.; Code 401 Nea Makri, Greece; PWO, Exmouth,
 Australia; PWO, Fort Amador Canal Zone
 NAVEDTRAPRODEVEN Tech. Library
 NAVEDUTRACEN Engr Dept (Code 42) Newport, RI

NAVFAC PWO, Broad Wings UK, PWO, Cape Hatteras, Buxton NC, PWO, Center of RQ, Elizabeth VA, PWO, Green
 NAVFAC PWO, Lewis DE
 NAVFAC ENGCOCM Code 043 Alexandria, VA, Code 044 Alexandria, VA, Code 045 Alexandria, VA, Code 0454B
 Alexandria, VA, Code 04B3 Alexandria, VA, Code 04B5 Alexandria, VA, Code 100 Alexandria, VA, Code 113, M
 Carr Alexandria, VA, Code 1113, E. Stevens Alexandria, VA, Code 1113 Alexandria, VA, Morrison Yap
 Caroline Is., PW Brewer Alexandria, VA
 NAVFAC ENGCOCM CHES DIV. Code 101 Wash. DC., Code 403 (H. DeVoe) Wash. DC., Code 405 Wash. DC.
 NAVFAC ENGCOCM TANT DIV. (CDRE Pelner), Code 111, Norfolk VA., Eur. BR Deputy Dir, Naples Italy
 European Branch, New York, RDI&F/O 102, Norfolk VA
 NAVFAC ENGCOCM NORTH DIV. CO. Code 1028, RDI&F/O, Philadelphia PA., Code 113, Costranovo
 Philadelphia, PA, Code 114 (A. Rhoads), Design Div. (R. Masino), Philadelphia PA., ROICC, Contracts, Crane IN
 NAVFAC ENGCOCM PAC DIV. (Kyo) Code 101, Pearl Harbor, HI., Code 2011 Pearl Harbor, HI., Code 402, RDI&F
 Pearl Harbor HI., Commander, Pearl Harbor, HI.
 NAVFAC ENGCOCM SOUTH DIV. Code 90, RDI&F/O, Charleston SC
 NAVFAC ENGCOCM WEST DIV. 102, 112, AROICC, Contracts, Twentynine Palms CA, Code 04B San Bruno, CA
 09P 20 San Bruno, CA, RDI&F/O Code 2011 San Bruno, CA
 NAVFAC ENGCOCM CONTRACT AROICC, Point Mugu CA., AROICC, Quantico, VA, Code 05, TRIDENT
 Bremerton WA., Dir. Eng. Div., Exmouth, Australia, Eng Div dir, Southwest Pac, Manila, PL, OICC, Southwest
 Pac, Manila, PL, OICC, ROICC, Balboa Canal Zone, ROICC, AF Guam, ROICC, TANT DIV., Norfolk VA., ROICC
 OH Point Mugu, CA, ROICC, Keflavik, Iceland, ROICC, Pacific, San Bruno CA
 NAVHOSPITER, Elisbernd, Puerto Rico
 NAVSU PWRU MUSE DE I Code NPU 30 Port Hueneme, CA
 NAVOCLASSYSSEN Code 41, San Diego, CA, Code 6700, San Diego, CA., Tech Library, Code 447
 NAVORDSTA PWO, Louisville KY
 NAVPLOTTE Code 30, Alexandria VA
 NAVPHIBASE CO, ACB 2 Norfolk, VA
 NAVRADREFAC PWO, Kam Seva Japan
 NAVRIGMIDCEN Chief of Police, Camp Pendleton CA, PWO Newport RI, PWO Portsmouth, VA, SCE (D. Kave),
 SCE San Diego, CA, SCE, Camp Pendleton CA, SCE, Guam, SCE, Oakland CA
 NAVSCE/CF/COFF C35 Port Hueneme, CA., CO, Code C44A Port Hueneme, CA
 NAVSICGRUACT PWO, Adak AK, PWO, Edzell Scotland, PWO, Puerto Rico, PWO, Torri Sta, Okinawa
 NAVSHIPRIPLAC SCE, Subic Bay
 NAVSHIPYD: Code 202 4, Long Beach CA., Code 202 5 (Library) Puget Sound, Bremerton WA., Code 380,
 (Woodroff) Norfolk, Portsmouth, VA., Code 400, Puget Sound, Code 400 03 Long Beach, CA., Code 404 (E. J.
 Riccio, Norfolk, Portsmouth VA., Code 410, Mare Is., Vallejo CA; Code 440 Portsmouth NH., Code 440, Norfolk,
 Code 440, Puget Sound, Bremerton WA.; Code 450, Charleston SC; Code 453 (Util. Supr), Vallejo CA.; J. D. Vivian,
 Library, Portsmouth NH; PWD (Code 400), Philadelphia PA; PWO, Mare Is., PWO, Puget Sound; SCE, Pearl
 Harbor HI; Tech Library, Vallejo, CA
 NAVSTA CO Naval Station, Mayport FL; CO Roosevelt Roads P.R. Puerto Rico; Dir Mech Engr, Gtmo; Engr, Dir.,
 Rota Spain; Long Beach, CA; Maint, Cont. Div., Guantanamo Bay Cuba; Maint. Div. Dir Code 531, Rodman Canal
 Zone; PWO Midway Island; PWO, Keflavik Iceland; PWO, Mayport FL; ROICC, Rota Spain; SCE, Guam; SCE,
 San Diego CA; SCE, Subic Bay, R.P.; Utilities Engr Off. (A.S. Ritchie), Rota Spain
 NAVSUBBASE ENS S. Dove, Groton, CT; SCE, Pearl Harbor HI
 NAVSUPPACT CO, Seattle WA: Code 4, 12 Marine Corps Dist, Treasure Is., San Francisco CA; Code 413, Seattle
 WA; I JG McGarragh, SEC, Vallejo, CA; Plan Engr Div., Naples Italy
 NAVSUREWPNCEN PWO, White Oak, Silver Spring, MD
 NAVTECHTRACEN SCE, Pensacola FL
 NAVWPNCEN Code 2636 (W. Bonner), China Lake CA; PWO (Code 26), China Lake CA; ROICC (Code 702), China
 Lake CA
 NAVWPNSTA (Clebak) Colts Neck, NJ; Code 092, Colts Neck NJ; Code 092A (C. Fredericks) Seal Beach CA; Maint.
 Control Dir., Yorktown VA
 NAVWPNSTA PW Office (Code 09C1) Yorktown, VA
 NAVWPNSUPPCEN Code 09 Crane IN
 NCBU 405 OIC, San Diego, CA
 PWC Code 420, Pensacola, FL
 NCBCEI, AOIC Port Hueneme CA; Code 10 Davisville, RI; Code 155, Port Hueneme CA; Code 156, Port Hueneme,
 CA; Code 400, Gulfport MS; PW Engrg, Gulfport MS; PWO (Code 80) Port Hueneme, CA; PWO, Davisville RI
 NCBU 411 OIC, Norfolk VA

NCR 20, Commander
 NCSO BAHRAIN Security OIB, Bahrain
 NMCRS, Operations Dept., Fort V. CO. THREE, Operations OIB
 NORDA Code 440 (Ocean Rsch OIB) Bay St. Louis MS
 NSC Code 54 (Warner) Norfolk VA
 NSD SCE, Subic Bay, RP
 NTC, Commander Orlando, FL
 NUSC Code 131 New London, CT, Code 1A123 (RS Munro) New London CT
 OCEAN SYSTEMS CENTER, Guaccola, Norfolk VA
 OFFICE SECRETARY OF DEFENSE (OASD/MRA&I) Pentagon (E. Casberg) Washington, DC
 ONR Code 700F Arlington VA
 PHIBRU P&E, Coronado, CA
 PMIC Pat. Counsel, Point Mugu CA
 PWC ACE Office (LIG St. Germain) Norfolk VA, CO Norfolk, VA, CO (Code 10), Oakland, CA, CO, Great Lakes II, Code 10, Great Lakes, II, Code 120, Oakland CA, Code 120C (Library) San Diego, CA, Code 128, Guam, Code 154, Great Lakes, II, Code 200, Great Lakes II, Code 220 Oakland, CA, Code 220 E, Norfolk VA, Code 300, San Diego, CA, Code 400, Great Lakes, II, Code 400, Oakland, CA, Code 400, Pearl Harbor, HI, Code 400, San Diego, CA, Code 420, Great Lakes, II, Code 420, Oakland, CA, Code 42B (R. Pascua), Pearl Harbor HI, Code 505A (H. Wheeler), Code 600, Great Lakes, II, Code 601, Oakland, CA, Code 610, San Diego CA, UJG 14 McClane, Yokosuka, Japan, Utilities Officer, Guam, XO (Code 20) Oakland, CA
 SPC PWO (Code 120) Mechanicsburg PA
 NAF PWO (Code 30) Ft Centro, CA
 U.S. MERCHANT MARINE ACADEMY, Kings Point, NY (Reprint Custodian)
 USCG (Smith), Washington, DC, G-FOF-461 (E. Dowd), Washington DC
 USSACH Mech. Engr. Dept Annapolis MD, PWD Engr. Div. (C. Bradford) Annapolis MD
 CORNELL UNIVERSITY Ithaca NY (Serials Dept. Engr Lib.)
 DAMES & MOORE LIBRARY LOS ANGELES, CA
 ILLINOIS STATE GEO. SURVEY Urbana IL
 LEHIGH UNIVERSITY Bethlehem PA (Linderman Lib. No. 30, Flecksterner)
 LIBRARY OF CONGRESS WASHINGTON, DC (SCIENCES & TECH DIV)
 MIT Cambridge MA, Cambridge MA (Rm 10-500, Tech. Reports, Engr. Lib.)
 NEW MEXICO SOLAR ENERGY INST. Dr. Zwibel Las Cruces NM
 NY CITY COMMUNITY COLLEGE BROOKLYN, NY (LIBRARY)
 PURDUE UNIVERSITY Lafayette, IN (CE Engr. Lib)
 CONNECTICUT Hartford CT (Dept of Plan. & Energy Policy)
 UNIVERSITY OF CALIFORNIA Berkeley CA (E. Pearson)
 UNIVERSITY OF DELAWARE Newark, DE (Dept of Civil Engineering, Chesson)
 UNIVERSITY OF ILLINOIS URBANA, IL (LIBRARY)
 UNIVERSITY OF MASSACHUSETTS (Heronemus), Amherst MA CE Dept
 UNIVERSITY OF NEBRASKA-LINCOLN Lincoln, NE (Ross Ice Shelf Proj.)
 UNIVERSITY OF TEXAS Inst. Marine Sci (Library), Port Arkansas TX
 UNIVERSITY OF WISCONSIN Milwaukee WI (Ctr of Great Lakes Studies)
 URS RESEARCH CO. LIBRARY SAN MATEO, CA
 BECHTEL CORP. SAN FRANCISCO, CA (PHELPS)
 BROWN & CALDWELL E. M Saunders Walnut Creek, CA
 CANADA Trans-Mnt Oil Pipe Lone Corp. Vancouver, BC Canada
 COLUMBIA GULF TRANSMISSION CO. HOUSTON, TX (ENG. LIB.)
 DURLACH, O'NEAL, JENKINS & ASSOC. Columbia SC
 FORD, BACON & DAVIS, INC. New York (Library)
 GLIDDEN CO. STRONGSVILLE, OH (RSCH LIB)
 LOCKHEED MISSILES & SPACE CO. INC. Sunnyvale, CA (K.L. Krug)
 MCDONNELL AIRCRAFT CO. Dept 501 (R.H. Fayman), St Louis MO
 RAYMOND INTERNATIONAL INC. E. Colle Soil Tech Dept. Pennsauken, NJ
 SANDIA LABORATORIES Seabed Progress Div 4536 (D. Talbert) Albuquerque NM
 WISS, JANNEY, ELSTNER, & ASSOC Northbrook, IL (D.W. Pfeifer)
 BRAHTZ La Jolla, CA
 BRYANT ROSE Johnson Div, UOP, Glendora CA
 R.F. BESIER Old Saybrook CT
 T.W. MERMEL Washington DC

LMED
-8