

UNCLASSIFIED

SECURITY CLASSIFICATION OF THIS PAGE (When Data Entered)

REPORT DOCUMENTATION PAGE

READ INSTRUCTIONS BEFORE COMPLETING FORM

ADA 085550

1. REPORT NUMBER SAM-TR 79-427	2. GOVT ACCESSION NO. ADA085550	3. RECIPIENT'S CATALOG NUMBER 9
4. TITLE (and Subtitle) DEVELOPMENT, TEST AND EVALUATION OF AN ADVANCED ANTI-G VALVE FOR THE F-15		5. TYPE OF REPORT & PERIOD COVERED Final Report, 1 Jan 77- 1 Jan 79
6. AUTHOR(s) R. R./Burton/ R. M./Shaffstal/ J. L./Jaggars		7. PERFORMING ORG. REPORT NUMBER
8. PERFORMING ORGANIZATION NAME AND ADDRESS USAF School of Aerospace Medicine (VNB) Aerospace Medical Division (AFSC) Brooks Air Force Base, Texas 78235		9. CONTRACT OR GRANT NUMBER(s) 111 1980
10. CONTROLLING OFFICE NAME AND ADDRESS USAF School of Aerospace Medicine (VNB) Aerospace Medical Division (AFSC) Brooks Air Force Base, Texas 78235		11. PROGRAM ELEMENT, PROJECT, TASK AREA & WORK UNIT NUMBERS 62202F 7930/12-06
12. MONITORING AGENCY NAME & ADDRESS (if different from Controlling Office)		12. REPORT DATE 17 12
13. DISTRIBUTION STATEMENT (of this Report) Approved for public release; distribution unlimited.		13. NUMBER OF PAGES
14. DISTRIBUTION STATEMENT (of the abstract entered in Block 20, if different from Report)		14. SECURITY CLASS. (of this report) UNCLASSIFIED
15. SUPPLEMENTARY NOTES		15a. DECLASSIFICATION/DOWNGRADING SCHEDULE
16. KEY WORDS (Continue on reverse side if necessary and identify by block number) Acceleration, G protection, Anti-G valve, G-suit, G-valve, Anti-G suit, F-15 pilots, Life support equipment, and High-performance aircraft.		
17. ABSTRACT (Continue on reverse side if necessary and identify by block number) The USAF School of Aerospace Medicine (USAFSAM) Crew Technology Division has developed an advanced anti-G valve for pressurizing the anti-G suit during exposures to acceleration. The anti-G valve presently in fighter aircraft has been determined to operate too slowly for rapid onset of G, potentially causing pilots of high-performance aircraft to blackout, lose consciousness, and/or become fatigued. The time relationship to G-suit pressurization using the conventional anti-G valve was found to be sigmoidal, having two relatively slow pressurization phases--one early, and the other late, in the suit-inflation		

12 8

DTIC
EXTRACTED
MAY 28 1980

317000 gm

DDC FILE COPY.

UNCLASSIFIED

SECURITY CLASSIFICATION OF THIS PAGE (When Data Entered)

schedule. Elimination of these two slow phases was accomplished by: (a) pre-inflating the anti-G suit to 0.2 psi prior to an increase in G (called "Ready Pressure"); and (b) increasing the capacity of air flow through the anti-G valve (called "Hi-Flow"). The development of the Hi-Flow Ready Pressure (HFRP) anti-G valve by USAFSAM increased the rate of G-suit pressurization threefold. This HFRP anti-G valve was tested on eight F-15 pilots, using the centrifuge at the NAVAL Air Development Center, Warminster, PA. A comparison of this experimental valve with the conventional anti-G valve (presently operational in the F-15 aircraft) resulted in a high degree of pilot acceptance, because the HFRP valve had better valve response, reduced valve error scores, and allowed the pilots to tolerate high-G exposures with less effort. Subsequent flight tests of eighteen HFRP anti-G valves on F-15 aircraft established the valves to be reliable, having high pilot acceptance, and providing an extra 1 G in tolerance.

Accession For	
DTIC GRA&I	<input checked="" type="checkbox"/>
NSC TAB	<input type="checkbox"/>
Unannounced	<input type="checkbox"/>
Justification	
By	
Distribution/	
Availability Codes	
Dist	Availability for special
A	20

UNCLASSIFIED

SECURITY CLASSIFICATION OF THIS PAGE (When Data Entered)

Development, Test, and Evaluation of an Advanced Anti-G Valve for the F-15

R. R. BURTON, R. M. SHAFFSTALL, and J. L. JAGGARS

Crew Technology Division, Biodynamics Branch, U.S. Air Force School of Aerospace Medicine, Brooks Air Force Base, Texas 78235

BURTON, R. R., R. M. SHAFFSTALL, and J. L. JAGGARS. *Development, test, and evaluation of an advanced anti-G valve for the F-15*. Aviat. Space Environ. Med. 51(5):504-509, 1980.

The USAF School of Aerospace Medicine (USAFSAM) Crew Technology Division has developed an advanced anti-G valve for pressurizing the anti-G suit during exposures to acceleration. The anti-G valve now in fighter aircraft has been found to operate too slowly to counteract the rapid onset of G, possibly causing pilots of high-performance aircraft to black out, lose consciousness, and/or become fatigued. The time relationship to G-suit pressurization using the conventional anti-G valve was found to be sigmoidal, having two relatively slow pressurization phases—one early, and the other late—in the suit-inflation schedule. These two slow phases were eliminated by preinflating the anti-G suit to 0.2 lbs./in² (psi) prior to an increase in G (called "Ready Pressure"); and by increasing the air flow through the anti-G valve (called "Hi Flow"). The Hi Flow Ready Pressure (HFRP) anti-G valve developed by USAFSAM increased the rate of G-suit pressurization threefold. This valve was tested on eight F-15 pilots, using the centrifuge at the Naval Air Development Center, Warminster Pa. When this experimental valve was compared with the conventional anti-G valve now operational in the F-15 aircraft, the HFRP valve received a high degree of pilot acceptance because it had better valve response, reduced valve error scores, and allowed the pilots to tolerate high-G exposures with less effort. Subsequent flight tests of 18 HFRP anti-G valves on F-15 aircraft confirmed the valves to be reliable, have high pilot acceptance, and provide an extra 1 G in tolerance.

THE ANTI-G VALVE now used for pressurizing the anti-G suit during exposures to acceleration in fighter aircraft has been reported to operate too slowly for the rapid G-onset capability of the new high-

*The bench test consisted of activating an anti-G valve instantly to its maximum capability and measuring the time required to inflate (pressurize) the abdominal bladder of an 11-liter "captured" anti-G suit to its pressure limit of 10 psi.

**Alar Products, Inc., 9100 Valleyview Rd., Macedonia, Oh 44056.

***The voluntary informed consent of the subjects used in this research was obtained in accordance with AFR 80-33.

****Although sufficient console space is readily available in the F-15 for a larger valve, the final design of a production-model HFRP anti-G valve will require the same space in the console as is now available for the F-15 anti-G valve.

performance F-15 aircraft. Since an inadequately functioning anti-G valve can cause pilots of these aircraft to black out, lose consciousness, and/or become overly fatigued, a valve was required that would be more responsive to rapid increases in G. Consequently, the USAF School of Aerospace Medicine (USAFSAM) Crew Technology Division has developed an advanced anti-G valve for use in the F-15. The results of the development, test, and evaluation of this anti-G valve are reported here.

DEVELOPMENT OF ADVANCED VALVES

The time required for pressurizing the abdominal bladder of the anti-G suit with the operational F-15 anti-G valve was measured using a "bench test"* at 1 G. This suit-pressurization relationship with time was sigmoidal, having two relatively slow pressurization phases—one early and the other late in the inflation schedule (Fig. 1). For the inflation rate to be significantly improved, these slow phases of suit inflation would have to be eliminated. This elimination was attempted by: preinflating the anti-G suit prior to an increase in G, and by increasing the capacity of air flow through the anti-G valve.

Preinflation Device: A device that preinflates the anti-G suit was developed in the laboratory at USAFSAM (Fig. 2). This unit maintains suit pressure at 1 G (called Ready Pressure, RP) by spring tension, using a lever (small arrow, Fig. 2) against the valve's press-to-test button. RP is controlled to ± 5 torr via a

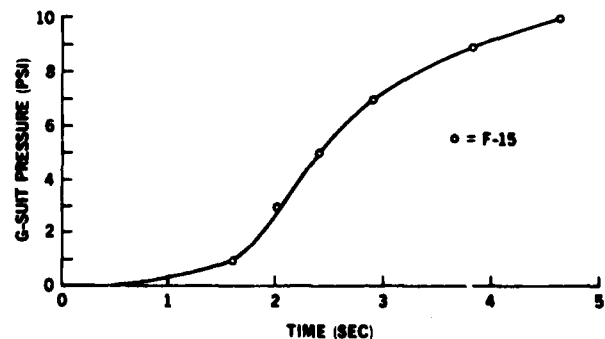

Fig. 1. Results of a bench test of the anti-G valve in the F-15. Approximately 5 s are required before the abdominal bladder is pressurized to 10 psi.

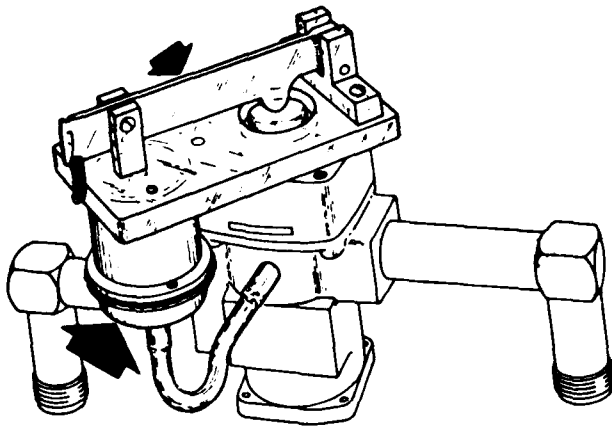

Fig. 2. A preprototype model of the Ready Pressure unit attached to an Alar anti-G valve. The action of the spring-forced lever (small arrow) against the press-to-test button is balanced against the force of the diaphragm (large arrow).

diaphragmed chamber (large arrow, Fig. 2) connected by a tube to the anti-G valve which monitors the G-suit pressure within the valve's second-stage pressurization chamber. Suit pressures greater than the RP, due to an increase in the accelerative field above 2 G, move the diaphragm up which lifts the lever off the press-to-test button. This inactivates the entire RP system. This experimental device is adjustable so that RP can be varied from 0.1 to 1 lbs/in² (psi). RP can be eliminated as necessary by mechanically lifting the RP lever off of the press-to-test button. The RP device was designed to be mated with the F-15 (Alar)** anti-G valve. RP at 0.2 psi reduces the air volume required to pressurize the suit by 60% during the onset of G.

Anti-G Valve Modification: Air flow to the anti-G suit through the F-15 anti-G valve was increased by enlarging several ports within the valve (Fig. 3). This modification increased the valve's air flow capacity by approximately 50%—air flow through the standard valve is approximately 15 ft³/min, whereas the modified valve has 22 ft³/min air flow. This modification was accomplished by Alar Products, Inc. under a USAFSAM contract. The modified valve is called the "Hi-flow" (HF) anti-G valve. The outward appearance (housing) of the HF valve is not different from the standard F-15 anti-G valve and therefore can accom-

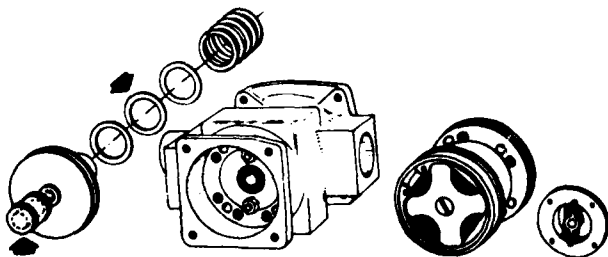

Fig. 3. Schema of the modification of the F-15 anti-G valve. The modifications are shown in black. Arrows point to additional modifications—an enlarged piston and the addition of three spacers.

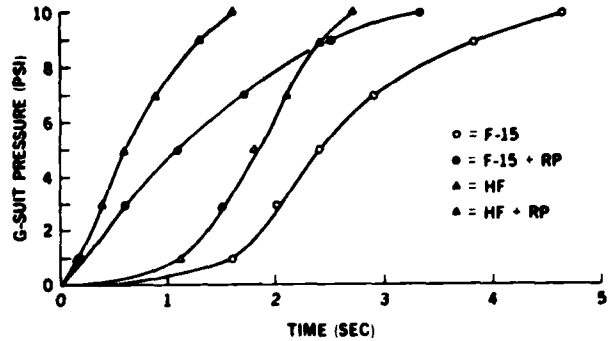

Fig. 4. Results of a bench test of three experimental anti-G valves compared with the test results (Fig. 1) of the F-15 anti-G valve. "F-15" designates the anti-G valve now used in the F-15. "HF" designates the Hi-Flow experimental anti-G valve, and "RP" specifies the ready-pressure unit.

modate the USAFSAM developed RP device.

Types of Experimental Anti-G Valves: Since the RP device could be mated with the F-15 anti-G valve or with the experimental HF anti-G valve, three experimental anti-G valves were made available for testing as potential replacements for the present F-15 anti-G valve: 1) HF valve without RP; 2) F-15 valve with RP; and 3) HF valve with RP (HFRP anti-G valve).

The maximum rates of anti-G suit inflation using the three experimental valves were determined by bench test at 1 G. These inflation schedules are compared in Fig. 4 with the inflation rate of the standard F-15 valve previously shown in Fig. 1. The functional capabilities of the three experimental anti-G valves are clearly superior to the standard F-15 anti-G valve. As had been expected, RP eliminated the initial delay in anti-G suit inflation, and the increased flow capability of the valve significantly improved the final slow phase of suit inflation. The combination of RP and HF had the greatest effect on the anti-G suit inflation schedule—reducing suit inflation times by approximately 75%.

TEST AND EVALUATION

The development of an acceptable improved anti-G valve required several types of test and evaluation (T&E) of the three advanced anti-G valves to determine: 1) the amount of improvement in G protection over the F-15 valve; 2) which of these experimental valves gave the greatest G protection; 3) if any of these valves inflated the anti-G suit too rapidly, potentially causing discomfort to the pilot; 4) if these experimental anti-G valves could be made airworthy; and 5) the acceptability of these valves—both in the laboratory and in the cockpit—by F-15 pilots experiencing aerial combat maneuvers. Several of these determinations were first made in the laboratory, using F-15 pilots exposed to G on the centrifuge. Some of the evaluations could be made only by flight testing in F-15 aircraft. Consequently, three types of T&E were conducted: a) laboratory T&E using a centrifuge, b) flight-worthiness T&E in F-15 aircraft, and c) initial operational T&E (IOT&E) in a squadron of F-15 aircraft.

Laboratory Test and Evaluation of Experimental

Anti-G Valves: Since the anti-G suit provides the G protection, the majority of data required to evaluate an anti-G valve must be obtained from anti-G suit function. Consequently, a test plan was developed based on physiologic functions, using the anti-G suit to determine if any of our experimental anti-G valves were an improvement over the valve now used in the F-15. The principal test criteria were G protection and pilot acceptance. Pilot acceptance is critical since anti-G suits and valves are dynamic equipment that are intimate with the pilot. Naturally, since pilot acceptance would include some evaluation of G protection, final selection of the best valve used a combination of both criteria.

Since there are few known *objective* measurements that critically evaluate pilot acceptance and G protection of suits and valves, many of the data had to be *subjective*. Consequently, selection of the type of subjects to be used in this laboratory test was important, and F-15 pilots were the subjects of choice. Eight F-15 pilot, volunteers from two USAF F-15 bases, were provided by TAC for this study.***

A functional test of these valves in the laboratory required using a centrifuge, and the choice of the centrifuge, the F-15 anti-G valve had performed adequately at the slower G-onset rates of 1 G/s. However, the F-15 aircraft operates at rates of 2-3 G/s and above. The only centrifuge in the United States capable of exposing humans to such high G-onset rates is at the Naval Air Development Center (NADC), Warminster, Pa. Consequently, the study was performed with the cooperation of the U.S. Navy, using their centrifuge at NADC.

Centrifuge testing of the experimental anti-G valves with F-15 pilots used several 7-G exposures of 10 s each, as well as a simulated aerial combat maneuver (SACM) with G-onset rates of 6 G/s (Fig. 5). In comparing the four anti-G valves, including the F-15 operational valve, the eight pilots were not informed before or during the study about any of the valves to be tested—a blind type of experiment.

Several subjective parameters were considered by the pilots in measuring G protection and valve acceptance: fatigue, effort, anti-G suit support of the pilot at 7 G

TABLE I. COMPARISON OF THE HFRP ANTI-G VALVE WITH THE F-15 ANTI-G VALVE

Parameter	HFRP vs F-15 Effect (Δ%)**	p<*
Fatigue	reduced (54%)	N.S.†
Effort	reduced (39%)	0.05
Heart Rate	no difference	—
Heart Rhythm	no difference	—
Light Loss (visual criteria)	no difference	—
Suit Pressure @:		
7 G	improved (42%)	0.01
G-onset of		
1 G/s	improved (37%)	0.01
3 G/s	improved (41%)	0.02
6 G/s	improved (51%)	0.02
Valve Error Scores:††		
1 G/s	reduced (22%)	0.001
3 G/s	reduced (30%)	0.001
6 G/s	reduced (33%)	0.001
Pilot Evaluation Scores	high acceptance	0.001

*Paired t-test; † Not significant (p>0.05); **Δ% = [(F-15) - (HFRP)/F-15] × 100; †† Note test and Fig. 6.

during various G-onset rates, and a pilot acceptance score. Objective evaluation criteria included subject's heart rhythm and rate, visual criteria of light loss, and a scoring method for anti-G suit inflation rates.

Although maximum air flow through the four anti-G valves had been determined at 1 G, using a type of bench test was noted previously (Fig. 4), another objective measure of valve response was devised for use with the centrifuge during a G exposure. The analog voltage response from the accelerometer (G profile) on the centrifuge was equated to the analog voltage response of the anti-G suit pressure inflation profile. The deviation of the suit pressure from the accelerometer was integrated and called "G-suit inflation error" (Fig. 6).

The results of the laboratory test and evaluation at NADC are shown as mean scores and are compared between only the HFRP valve and the F-15 valve (Table I). Although the other experimental valves were also considered to be an improvement over the F-15 valve, the HFRP anti-G valve clearly was the best.

Several questions were asked of the pilots regarding

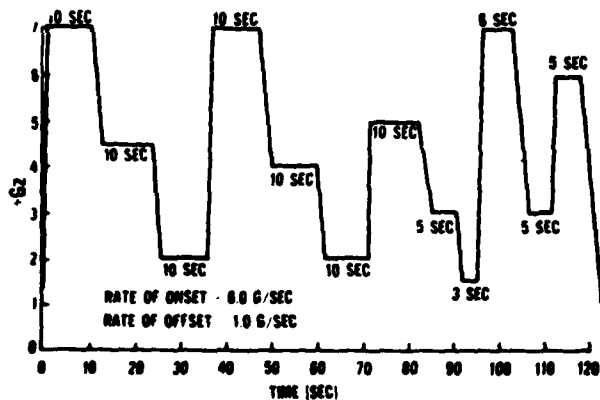

Fig. 5. Simulated aerial combat maneuver (SACM) used by the F-15 pilots to evaluate the experimental anti-G valves.

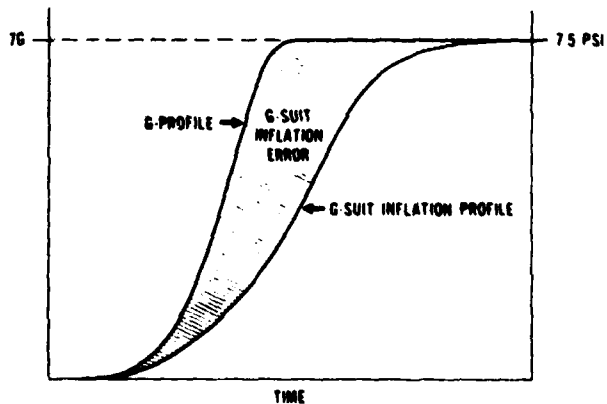

Fig. 6. Method of determining G-suit inflation error during centrifugation. The error score is without physical dimensions. A smaller error score identified an improved anti-G valve.

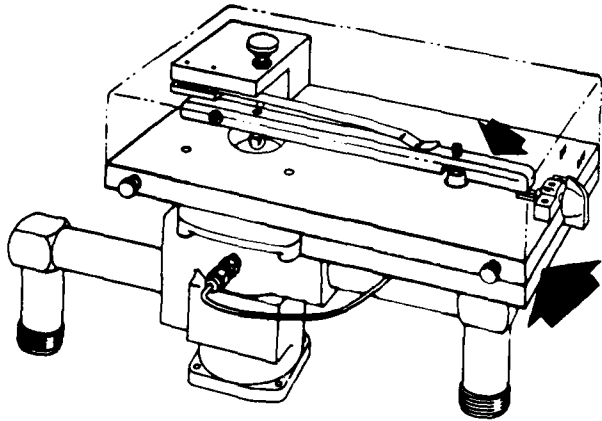

Fig. 7. Schema of the prototype flightworthy HFRP anti-G valve. Small arrow identifies the spring-forced lever of the RP unit, and large arrow indicates the location of the diaphragm of the unit (Fig. 2).

their opinion on the use of RP in the F-15. All pilots stated that they liked the idea of RP; 0.2 psi of RP was comfortable at 1 G; and they would use RP if it were in the F-15. They all preferred an on/off switch for RP since they planned to use it only during aerial combat maneuvers.

A detailed USAFSAM Technical Report on this study has been prepared and is available (4).

The HFRP anti-G valve was proposed by USAFSAM to the Aeronautical Systems Division, Life Support SPO (ASD/AEL) as the candidate improved anti-G valve for the F-15. Although the other experimental valves were an improvement over the F-15 valve and would be slightly less expensive to the USAF than the HFRP valve, the superior performance of the HFRP valve justified its selection for further test and evaluation.

When the final report on the results of the laboratory test of the HFRP anti-G valve was submitted, recommending the HFRP anti-G valve for further develop-

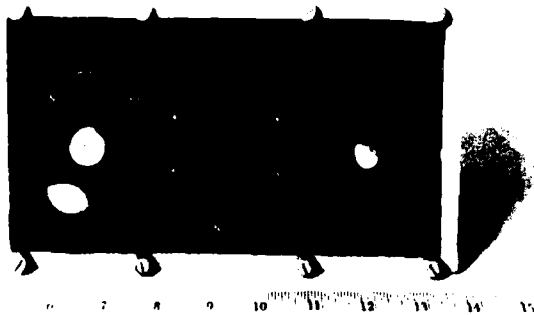

Fig. 8. F-15 console panel for the HFRP anti-G valve, shown with a ruler marked in inches. The on/off switch for RP is on the left of the panel, and the press-to-test button is on the right. The class II modification designation, attached to the center of the panel, was required for both the flightworthiness test and the IOT&E. The opening in the lower left corner is for the hose of the anti-G suit.

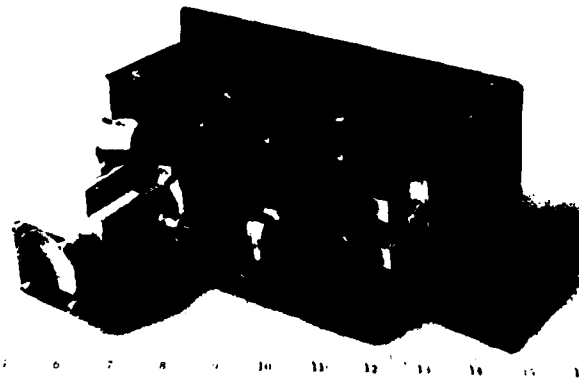

Fig. 9. HFRP anti-G valve attached beneath the console panel shown in Fig. 8. The ruler is marked in inches. Metal tubing connects the valve's second stage (anti-G suit pressure) to the diaphragm chamber of the RP unit. Mechanism of the on/off switch for RP is on the right, near the opening in the panel for the anti-G suit hose.

ment for the F-15, ASD/AEL decided to proceed with the flightworthiness test of this valve on F-15 aircraft.

Flightworthiness Test of the HFRP Anti-G Valve: A flightworthy prototype HFRP anti-G valve was developed from the preprototype HFRP anti-G valve shown in Fig. 2. A schema of the flightworthy HFRP anti-G valve is shown in Fig. 7. The RP device of this valve was designed and manufactured by USAFSAM; the HF anti-G valve was manufactured by Alar Products, Inc.** The HFRP anti-G valve was assembled by USAFSAM. The space requirement in the F-15 console for the HFRP anti-G valve is slightly more than twice that for the standard anti-G valve.**** The F-15 console panel for the preproduction HFRP anti-G valve is shown in Fig. 8, and a view of the HFRP valve attached to the console panel is in Fig. 9.

Three HFRP valves with F-15 panels were provided by USAFSAM for the flightworthiness test at the Air Force Flight Test Center (AFFTC), Edwards AFB, Ca, where their F-15 test aircraft were used.

The AFFTC test plan for the HFRP valve proposed a minimum requirement of four flights by at least two pilots. The test objectives were to: a) verify that the valve did not interfere with pilot function; b) identify potential human factors' problems; c) obtain pilot opinion of valve performance; and d) complete flightworthiness validation of valve function. Col. N. L. Suits (FFTC/TEVV) was the Project Director, Capt. V. P. Saxon (FFTC/TEVV) was the Project Manager, and Capt. R. C. Hill (AFFTC/TEEFH) was the Project Engineer.

The actual flightworthiness test, however, was much more ambitious than the proposed requirement of the AFFTC test plan. Seven pilots flew the HFRP anti-G valve on three F-15 aircraft a total of 71 sorties, with an accumulated flight time of 82.4 h. Three of these pilots accounted for 82% of the sorties.

The HFRP anti-G valves were tested using the following flying maneuvers, with and without the use of RP: a) incremental +G_z turns up to 7.3 G, b)

— G_z exposures up to $-3 G_z$, c) rapid G-onset rates (5 G/s) up to $+5 G_z$, d) rapid G unload from $+4 G_z$ to $+1 G_z$, e) F-15 accelerations to Mach 2, f) a maximum altitude of 49,000 ft (14.9 km), and g) continuous exposures of RP for a maximum of 1.8 h. During these 71 sorties, the HFRP anti-G valve performed without fail with the anti-G suit always inflating in a satisfactory manner. Using a score of 7 as "excellent" and 1 as "poor," the pilots subjectively scored the HFRP valve function at 5.93.

The pilots made several remarks, all of which were positive, regarding the HFRP anti-G valve. Some specific remarks from different pilots were: ". . . the valve worked excellently throughout"; ". . . G-valve operated excellently"; "Good, positive G-suit inflation at 2.0 G, . . ."; "G-tolerance significantly improved . . ."; ". . . the new valve is a vast improvement over the GFE item." One pilot noted that less effort was required during an ACM using the HFRP valve than when using the standard F-15 valve. He also observed that less concentration on the M-1 was required during rapid G-onset while using the HFRP valve, possibly having a positive impact on his performance during an ACM.

After AFFTC declared the HFRP anti-G valve flight-worthy, TAC authorized an Initial Operational Test and Evaluation (IOT&E) project plan for flight testing 15 HFRP anti-G valves to be provided by USAFSAM.

IOT&E of the HFRP Anti-G Valve: Fifteen HFRP anti-G valves, similar to those supplied to AFFTC for the flightworthiness test, were produced by USAFSAM for the IOT&E. The IOT&E was planned and managed by TAWC under the direction of HQ TAC/DR. Holloman AFB, NM, 49th TFW, was chosen as the test site for the IOT&E. The valves were installed in nine F-15A and three (both front and back seats) F-15B aircraft.

After each flight and after the 2-month test period, 24 F-15 pilots completed questionnaires to evaluate the operation of the HFRP valves. A total of 106 ACM sorties were flown in 115.4 h. No valve failed during the entire test program.

The final results of the test showed favorable aircrew ratings and comments. Most pilots felt that the HFRP valve offered an additional 1 G of protection over the standard F-15 anti-G valve. The pilots found that the RP aspects of the valve did not significantly interfere with cockpit controls, aircrew duties, or other life support equipment, nor did it significantly increase anti-G suit discomfort. TAWC concluded ". . . that the valve significantly enhances G protection and that the slight interference and discomfort caused by the ready pressure features are justified by the benefits derived from the feature."

DISCUSSION

The importance of using F-15 pilots in the research phase of this anti-G valve development program cannot be over emphasized for two reasons: the anti-G system acts directly on the physiology of the pilot so the anti-G effect must be personally evaluated, and there are no adequate objective criteria for evaluating anti-G sys-

tems based on physiologic requirements in the high-G environment. This makes the anti-G system a unique category of life support equipment. Other life support equipment can be objectively quantified using physiologic parameters so that the support necessary to sustain the pilot can be calculated and therefore provided. Unfortunately, this is not possible with anti-G equipment. Also, since the anti-G equipment developed in the 1940s has been found adequate until now by pilots of high-performance aircraft, there has been little demand to develop general methods to adequately evaluate anti-G systems.

On the other hand, although specific methods to evaluate anti-G systems are more easily devised, these require the identification of specific deficiencies in that system. Consequently, the complaints by pilots that the anti-G suit inflated too slowly during rapid G-onset rates made it possible to modify the anti-G valve system so that this difficulty could be corrected. Once these modifications were perfected, specific methods could be developed to test these experimental valves and determine if the deficiencies had been eliminated. F-15 pilots were the logical choice to effectively evaluate these valve modifications, relative to their impact on the deficiency. These pilots were also needed to determine if *our* valve modifications in themselves (such as RP) would offer some difficulty for the pilot while flying the aircraft.

Since the F-15 valve was reported to be deficient only at rapid G-onset rates, the types of G exposures used to test the valves was critical. Five acceleration exposures were used, and always in this order: (1) 3 G for 15 s—1 G/s onset rate; (2) 7 G for 10 s—1 G/s onset rate; (3) 7 G for 10 s—3 G/s onset rate; (4) 7 G for 10 s—6 G/s onset rate; and (5) a simulated aerial combat maneuver with three 7-G peaks, with all increases in G at a 6 G/s onset rate (Fig. 5). Rests between G exposures were determined on an individual pilot preference and usually were less than 30 s. A 6 G/s onset rate was chosen because it is the highest onset rate possible at NADC without large G overshoots at 7 G. At the completion of the study, the F-15 pilots noted that 6 G/s would be the maximum they would use in an ACM. Several pilots thought 3-4 G/s onset rates were more realistic.

USAFSAM has found the ACM to be more appropriate as a G profile on the centrifuge for testing related to high-performance aircraft than the sustained-G exposures more commonly used in acceleration research (5). The pilots considered these high-G profiles, including the ACM, to be quite realistic and helpful to them in centrifuge testing the anti-G valve. In using the ACM, the pilots noted that the HFRP valve reduced the effort required by them to tolerate high G. Instituting this valve in the F-15 should significantly reduce pilot fatigue resulting from multiple ACM-type exposures (Table I).

Early in the developmental stage of our experimental valve program, we designed and used in the laboratory anti-G valves with controls that were mechanical, electronic, or fluidic. All of these valves were designed to allow various anti-G suit pressurization schedules to be tested in the laboratory on the USAFSAM centrifuge.

Human subjects, fitted with the USAF standard CSU 13 A/P anti-G suit or other types of anti-G suits, were exposed to a series of different anti-G suit pressurization schedules while experiencing various levels of G on the centrifuge (1-3). These earlier studies were of value in developing our knowledge of G protection relative to anti-G suit function. From these studies we learned that the abdominal bladder of the anti-G suit performs the principal anti-G function, and that applying anti-G suit pressure to the body as rapidly as possible is essential for optimum protection, especially at high G-onset rates.

The electronic anti-G valve was the most useful tool in these studies. The valve was reliable and very useful in the laboratory because of ease in programming it for a wide range of anti-G suit pressurization schedules. However, early in our program for developing an anti-G valve for the F-15, we discarded the idea of a programmable and very rapidly responding anti-G valve as too complex, especially since electronic controls would be required. Involving the electronics of a fighter aircraft posed complications that appeared to be too great to justify for simply controlling anti-G suit pressure.

Instead of a complex anti-G valve that rapidly responded to an increase in G, we decided to preinflate the anti-G suit to a low pressure before involving G. What made this low-pressure preinflation so attractive was the exponential relationship of suit volume as a function of suit pressure; i.e. at a low suit pressure of 0.2 psi, 60% of the suit volume is occupied with air. The remaining 10.3 psi (10.5 psi is the maximum possible suit pressure) occurs with the remaining 40% suit volume—98% of anti-G suit pressurization is produced with 40% of the suit volume.

The concept of RP as a method to increase the rate of anti-G suit inflation, therefore, allowed development of a mechanical type of anti-G valve. We were attracted to the mechanical valve as opposed to fluidic or electronic controls for several reasons: a) simplicity of valve design and construction, b) reliability of valve performance, c) ease of valve installation, and therefore d) lower costs to the USAF. We knew the above reasons were justified from the 25 years of experience in the use of the type of mechanical anti-G valve presently found in jet aircraft.

Preinflation suit pressure above 1 psi causes considerable discomfort in subjects and has been found to reduce relaxed-G tolerance (2). On the other hand, less than 1 psi of preinflation pressure is not uncomfortable and does not significantly affect G tolerance. Once low preinflation suit pressures were shown to have minimal

physiologic effects on subjects, the use of preinflation (Ready Pressure) was clear as a method to increase the inflation rate of the anti-G suit. The level of 0.2 psi for RP was chosen because it was not uncomfortable for any of our subjects (higher pressure would be uncomfortable for some persons at 1 G), yet it was enough pressure to provide sufficient feedback to the valve to precisely control the level of RP.

Several laboratory tests were conducted on the HFRP anti-G valves prior to placing them in F-15 aircraft at AFFTC. These tests included: 20 G for 15 min; 160°F (70°C) for 8 h; 34,000-ft (10.4-km) altitude with rapid rate of climb; vibration test; and finally an endurance test by cycling the valve 5,000 times to 6 psi. The flightworthy model of the HFRP anti-G valve tolerated these tests without difficulty. These test results reinforced our decision to use a completely mechanical anti-G valve.

It appears that our reliance on a mechanical valve for reliability was justified. Although the HFRP anti-G valve program is still in its infancy regarding its use, we already have data on 177 F-15 high-G flights involving approximately 200 flight hours with 18 HFRP anti-G valves. No instance of valve failures have been reported, and 18 HFRP anti-G valves in F-15 aircraft have been installed with only minor problems.

The production of a flightworthy HFRP anti-G valve by USAFSAM for the early flight-tests and IOT&E has been useful in shortening the time requirements for much of this valve's development. The production of these valves by USAFSAM was made possible because of the successful development of a mechanical HFRP anti-G valve in our laboratory.

REFERENCES

1. Burton, R. R., J. L. Jaggars, and S. D. Leverett, Jr. 1976. Advances in G protection research. Aerospace Medical Association Preprints, pp. 29-30.
2. Burton, R. R., M. J. Parkhurst, and S. D. Leverett, Jr. 1973. +G_z Protection afforded by standard and preacceleration inflations of the bladder and capstan type G-suits. *Aerospace Med.* 44:488-494.
3. Burton, R. R., and R. W. Krutz, Jr. 1975. G-tolerance and protection associated with anti-G suit concepts. *Aviat. Space Environ. Med.* 46:119-124.
4. Burton, R. R., R. M. Shaffstall, J. L. Jaggars, K. K. Gillingham, K. W. Stevens, and S. D. Leverett, Jr. 1979. A new anti-G valve for high-performance aircraft. SAM-TR-79-27.
5. Burton, R. R., P. F. Iampietro, and S. D. Leverett, Jr. 1975. Physiologic effects of seatback angles <45° (from the vertical) relative to G. *Aviat. Space Environ. Med.* 46: 887-897.