



UNCLASSIFIED

SECURITY CLASSIFICATION OF THIS PAGE (When Data Entered)

REPORT DOCUMENTATION PAGE		READ INSTRUCTIONS BEFORE COMPLETING FORM
1. REPORT NUMBER CR-80.011	2. GOVT ACCESSION NO. AD-ACSS 612	3. RECIPIENT'S CATALOG NUMBER
4. TITLE (and Subtitle) Final Report 6 Validation of a Freezer Concept for a Desalination Unit		5. TYPE OF REPORT & PERIOD COVERED Contract Report June 1978 - Oct 1979
7. AUTHOR(s)		6. PERFORMING ORG. REPORT NUMBER
9. PERFORMING ORGANIZATION NAME AND ADDRESS Concentration Specialists, Inc. 26 Dundee Park Andover, MA 01810		8. CONTRACT OR GRANT NUMBER(s) N68305-78-C-0021
10. CONTROLLING OFFICE NAME AND ADDRESS Civil Engineering Laboratory U.S. Naval Construction Battalion Center Port Hueneme, CA 93060 R. S. Chapler, (805) 982-5925		11. PROGRAM ELEMENT PROJECT, TASK AREA & WORK UNIT NUMBERS 62760N, F60-536, F60- 536-091, F60-536-091-01-J50C
14. MONITORING AGENCY NAME & ADDRESS (if different from Controlling Office)		12. REPORT DATE April 1980
		13. NUMBER OF PAGES 29
		15. SECURITY CLASS. (of this report) Unclassified
		16. DECLASSIFICATION/DOWNGRADING SCHEDULE
18. DISTRIBUTION STATEMENT (of this Report) Approved for public release; distribution unlimited. F (11) YF605360		
17. DISTRIBUTION STATEMENT (of the abstract entered in Block 20, if different from Report)		
18. SUPPLEMENTARY NOTES		
19. KEY WORDS (Continue on reverse side if necessary and identify by block number) Desalination, Freezing, Smooth-tube, Crystallization, Nucleation, Defrost Cycle Seeding, Indirect Contact		
20. ABSTRACT (Continue on reverse side if necessary and identify by block number) Validation of a smooth-tube, indirect-contact freezer concept was conducted toward inclusion in the design of a modular 20,000 GPD freezing desalinator for use at Naval Advanced Bases. A 500 GPD model freezing desalinator consisting of freezers, crystal growth tank, wash column, melter and refrigeration system was used to test several flow schemes and freezer configuration having		

DD FORM 1473 1 JAN 73 EDITION OF 1 NOV 65 IS OBSOLETE

UNCLASSIFIED  
SECURITY CLASSIFICATION OF THIS PAGE (When Data Entered)

UNCLASSIFIED

SECURITY CLASSIFICATION OF THIS PAGE (When Data Entered)

either three or five concentric tube freezer elements. Simplicity in operating mode coupled with low pressure drop (low pumping costs) and high ice production rates (high heat transfer coefficients) were sought. A

To provide continuous operation, each of the freezer elements was periodically defrosted while the other elements were refrigerated. Brine was recirculated between the paralleled freezer elements and a crystal growth tank. Ice crystals accumulating at the top of the crystallizer were washed and scraped into an indirect contact melter prior to recombination with the brine stream from the wash column. The combined streams were then returned to the freezer/crystal growth tank recirculation loop.

Flow schemes were utilized with three and five freezer elements paralleled, with refrigerant forced circulation at two velocities, without refrigerant circulation, and with six different brine velocities from 6.0 fps to 18.9 fps. Reynolds' numbers varied from 11,600 to nearly 69,000. Tube side heat transfer coefficients were calculated to be from 784 Btu/hr-ft<sup>2</sup>°F to 2,360 Btu/hr-ft<sup>2</sup>°F with temperature differences between 6.8°C and 3.3°C, respectively.

Freezer element icing and plugging were encountered even at the highest Reynolds' numbers attained, i.e., >60,000. Defrosting was found to be required.

Positive results were obtained, in that ice in the form of a soft mass of small crystals similar to that produced in direct contact freezing processes was produced.

Inclusion of smooth-tube freezer design parameters developed in this effort into the preliminary design and sensitivity and economic analyses of a 20,000 gallon per day containerized freezing desalinator were not performed as originally planned, because it was judged that the fluidized bed freezer alternative would be less prone to freeze-up without significant increase in either pumping costs or system complexity.

## TABLE OF CONTENTS

	<u>PAGE</u>
Abstract.....	i
I. Introduction.....	1
II. Summary of Results.....	3
III. Process Description.....	5
IV. Equipment Description.....	9
V. Instrumentation.....	11
VI. Tests.....	13
VII. Recommendations.....	25

## FIGURES

1	General Process Diagram.....	6
2	Indirect Freezing Laboratory Pilot Plant.....	7
3	Freezer Flow Schemes for Freezing with Three and Five Tubes.....	8
4	Flow Schematic for Experimental Runs 500 GPD Indirect Freeze Pilot Plant.....	12
5	Freon Temperature in Defrosting Tubes.....	14
6	Temperature History for 28 Hour Run.....	17
7	Temperature Data Recorded after each Tube Defrosted, Scheme 4 (No Annulus).....	20
8	Temperature Data Recorded after each Tube Defrosted, Scheme 5 ( $D_h = 0.304$ in.).....	21
9	Temperature Data Recorded after each Tube Defrosted, Scheme 6 ( $D_h = 0.169$ in.).....	22

## TABLE

1	Freezing System Data for Different Brine Recirculation Flow Schemes.....	19
---	--------------------------------------------------------------------------	----

## I. INTRODUCTION

### Background

The Civil Engineering Laboratory (CEL) under the sponsorship of the Naval Facilities Engineering Command is developing an experimental freeze desalination unit, containerized to fit into an 8'x8'x20' ANSI container for application at advanced military bases. The target capacity of the unit is 20,000 gallons of potable water per day from a sea water supply.

The work is to be completed in four phases: Phase I - Preliminary Design; Phase II - Validation of Freezer Design Concept; Phase III - Final Design and Construction; and Phase IV - Test and Evaluation. Only Phase II is addressed in this report.

### Objective

This was a laboratory study to validate the freezer design concept and criteria developed in Phase I - "Preliminary Design of an Experimental Containerized Freeze Desalination Unit". Performance data was developed with a 500 GPD pilot plant.

### Approach

Due to a lack of positive results, the test data was insufficient to warrant any change in the conclusions reached in Phase I. Therefore, tasks related to modifying the freezer design criteria and the preliminary design of an experimental indirect contact freeze desalinators were not conducted. Instead, the time allotted to these tasks was used for further experimentation and emphasis was placed on validating the smooth tube freezer concept.

The testing program was a systematic search for conditions under which crystal growth would occur preferentially in the bulk brine solution or on seed crystals (ice) as they passed through the freezer rather than on the heat transfer surfaces of the freezer. The approach taken was to investigate the effect of each category listed below on freezer performance:

1. Defrost cycle operation
2. Bulk refrigerant velocity
3.  $\Delta T$  between brine and refrigerant
4. Bulk brine velocity
5. Seeding of the freezer

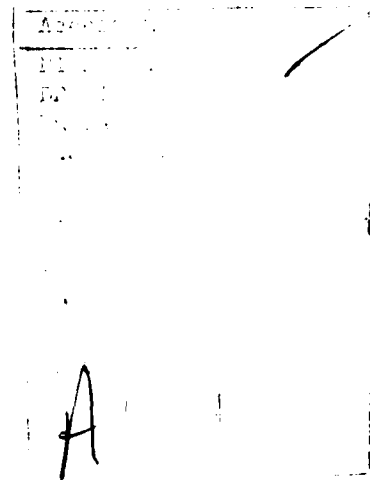

Then, where possible, the most positive effects from each category were combined for further investigations and data acquisition and system improvements were made based on the results. Proceeding in this fashion, conditions were reached under which nucleation and crystal growth occurred in the bulk brine solution and to a limited extent on the heat transfer surfaces of the freezer during the last week of testing.

All pilot plant runs were conducted in a closed loop mode which closely simulates actual operating conditions. The entire feed stream was taken from the melt loop and heated up to a  $1.7^{\circ}\text{C}$  by the melter to simulate the actual precooled feed of a freeze desalination plant.

## II. SUMMARY OF RESULTS

This investigation indicates that smooth tube indirect freezing has potential in freeze desalination but further development work is required. The smooth tube indirect freezer produced soft, very fine ice similar to that produced in direct contact processes, but crystal growth within the freezer occurred at such a rapid rate that the flow area became obstructed with ice. This ice plugged the freezer rather than freezing as a solid, hard mass and only small quantities of ice were produced intermittently. Further investigations are warranted in that the potential of smooth tube indirect freezing has not been fully explored since positive test results were obtained only during the last week of testing. Development of a means of continuously removing this soft, fine ice as it forms in the freezer appear likely and continuous production of substantial quantities of ice appear possible by smooth tube indirect freezing.

Conditions under which nucleation and crystal growth occurred in the bulk brine solution and to a limited extent on the heat transfer surfaces of the freezer are:

1. Fluid flow regimes which resulted in very large tube side heat transfer coefficients. The coefficients were estimated to be greater than  $1960 \frac{\text{BTU}}{\text{hr-ft}^2\text{-}^\circ\text{F}}$  by calculation.
2. Cooling and freezing with temperature differences less than  $4.6^\circ\text{C}$  between the bulk brine and the refrigerant in the freezer.
3. Defrosting each freezer tube separately until the refrigerant in the outer shell of the defrosting tube is warmed to slightly above the brine freezing point. At this point the defrosted tube is brought back into service and immediately another freezer tube is taken out of service and defrosted.

Other important conclusions derived from the test results, observations and experience with the freezer include:

1. Freezing conditions are best approached by gradual reductions in refrigerant temperature. Large temperature differences between brine and refrigerant resulted in the formation of an ice layer on the freezer tube walls severely limiting the heat transfer capabilities of the freezer.

2. Brine recirculation flow schemes through the freezer which resulted in very large tube side heat transfer coefficients provided the most positive test results. More heat was removed by the freezer and crystal growth occurred in the bulk brine solution in the freezer.
3. Seeding experiments in which ice nuclei were circulated through the freezer resulted in very little ice production under the conditions investigated.
4. The shearing action of turbulence up to Reynolds Numbers of 60,000 was ineffective in preventing the formation of an ice layer on the inside tubes of the freezer. An effective defrosting scheme was required to prevent the accumulation of ice on the heat transfer surfaces of the freezer under all the conditions tested.

### III. PROCESS DESCRIPTION

Figure 1 is a process schematic of the indirect freezing system used in this test program. Figure 2 is photographs of the equipment. The system has a nominal capacity of 500 GPD potable water. The indirect freezer is a concentric tube heat exchanger with refrigerant in the outer shell and brine flowing through the inner tube. The inner tube is polished stainless steel. This was used to minimize nucleation sites for ice growth on the tube wall. Using a multiplicity of tubes operating in series and parallel, several flow configurations through the freezer are possible. The two flow configurations used for these tests are shown in Figure 3, with the center tube defrosting in each case.

The freezer operates with one tube out of service for defrosting at all times; the remaining tubes provide the cooling. Defrosting is accomplished by closing the inlet and outlet refrigerant valves to the tube being defrosted while passing the brine feed stream through that tube. The precooled feed enters the freezer at about 1.7°C (35°F). The few degrees of sensible heat above freezing remove ice adhering to the tube wall.

Refrigerant 22 is evaporated in the shell of the freezer and compressed to about 214 psia (37°C). A portion of the compressed gas is used to melt the ice in the melter and the remainder is condensed in the heat rejection exchanger.

Crystal growth occurs by recirculating brine or ice slurry from the crystallizer tank through the freezer. Ice slurry from the crystallizer tank is pumped to the wash column where it is washed by a portion of the melt. The ice is scraped from the top of the wash column and slurried to the melter where it is melted by the condensing refrigerant and becomes wash water and pure product water.

**LEGEND:**

- REFRIGERANT LINES
- WATER, BRINE, VAPOR
- VENT LINE
- PNEUMATIC LINES

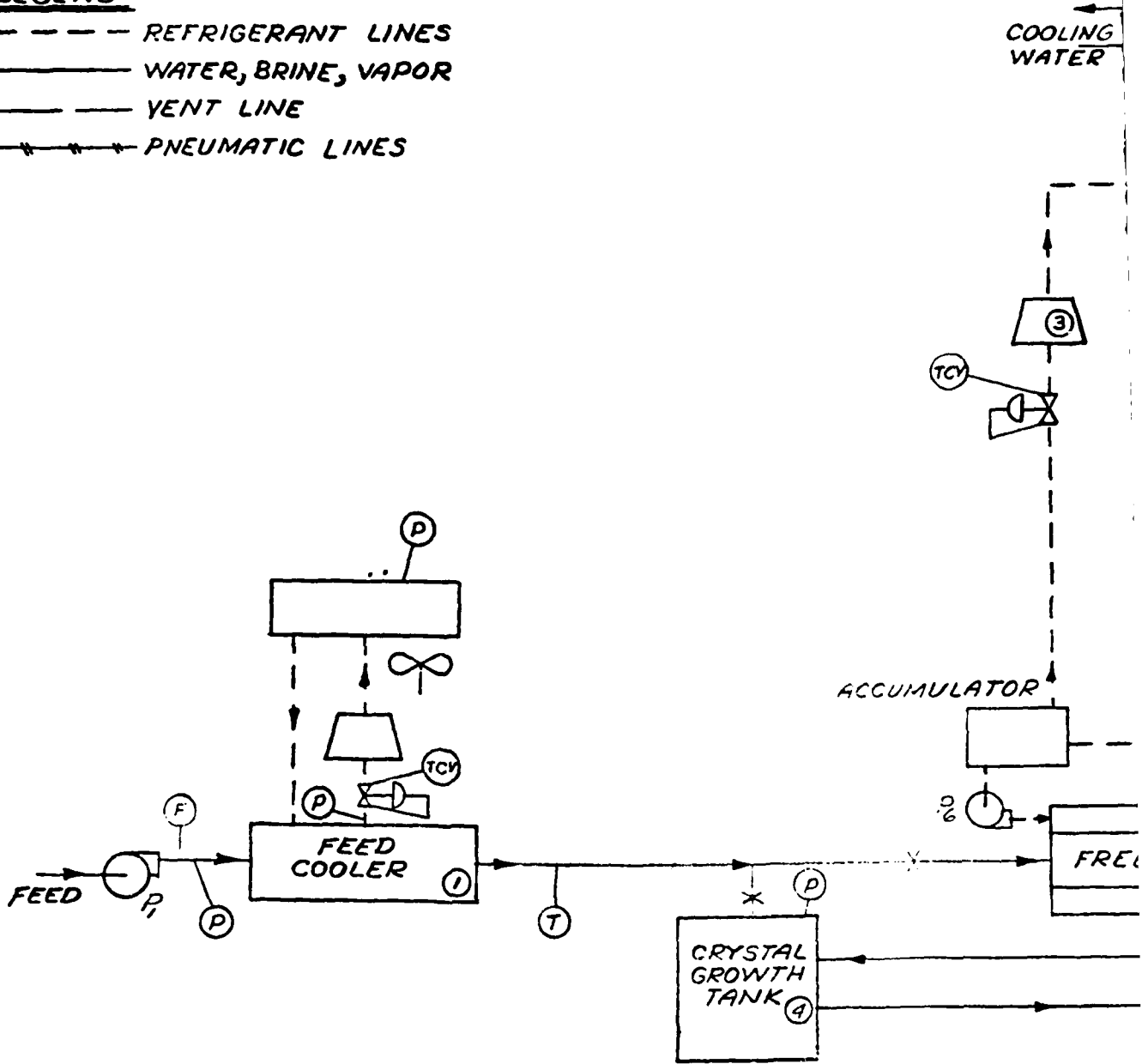
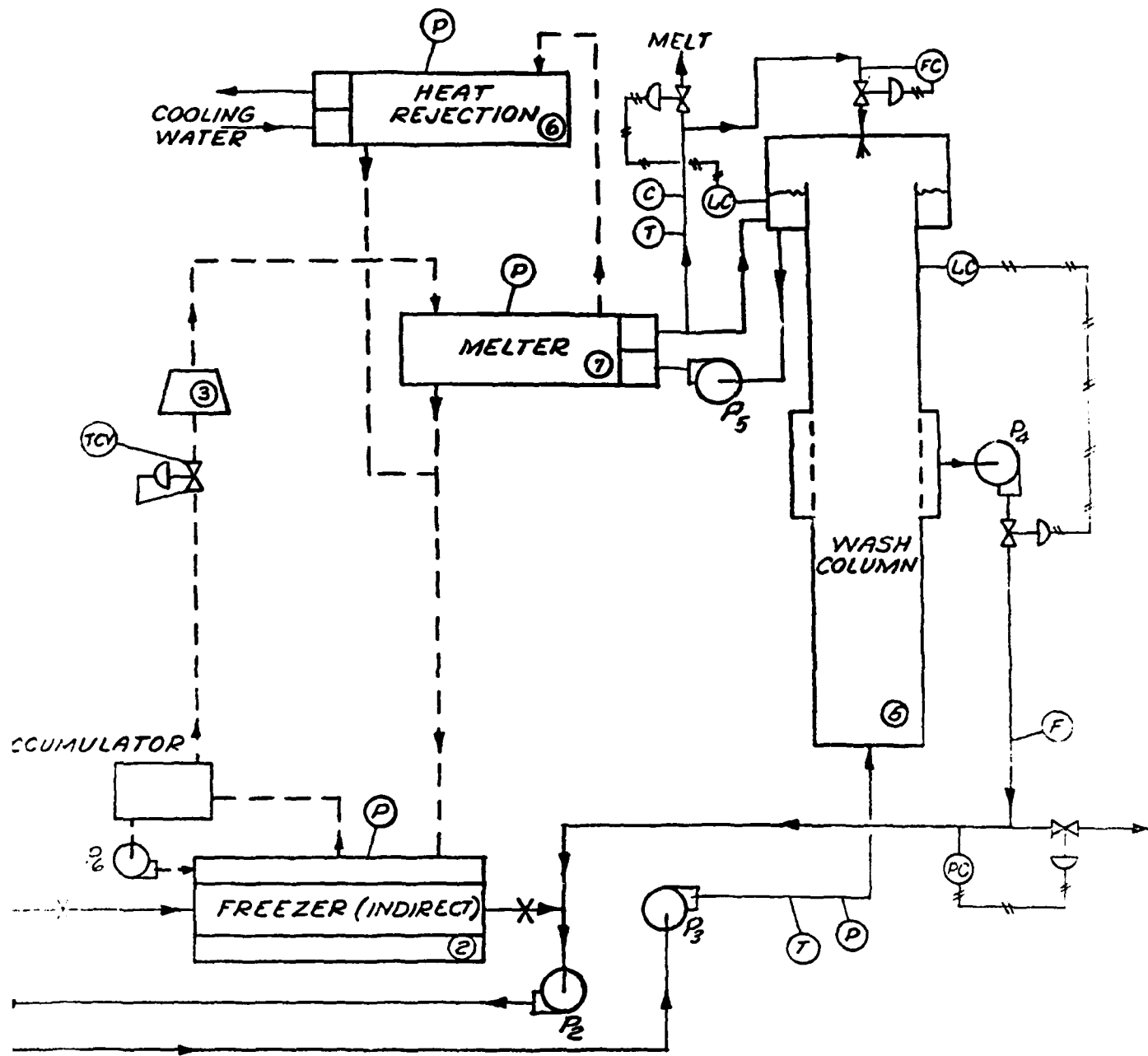
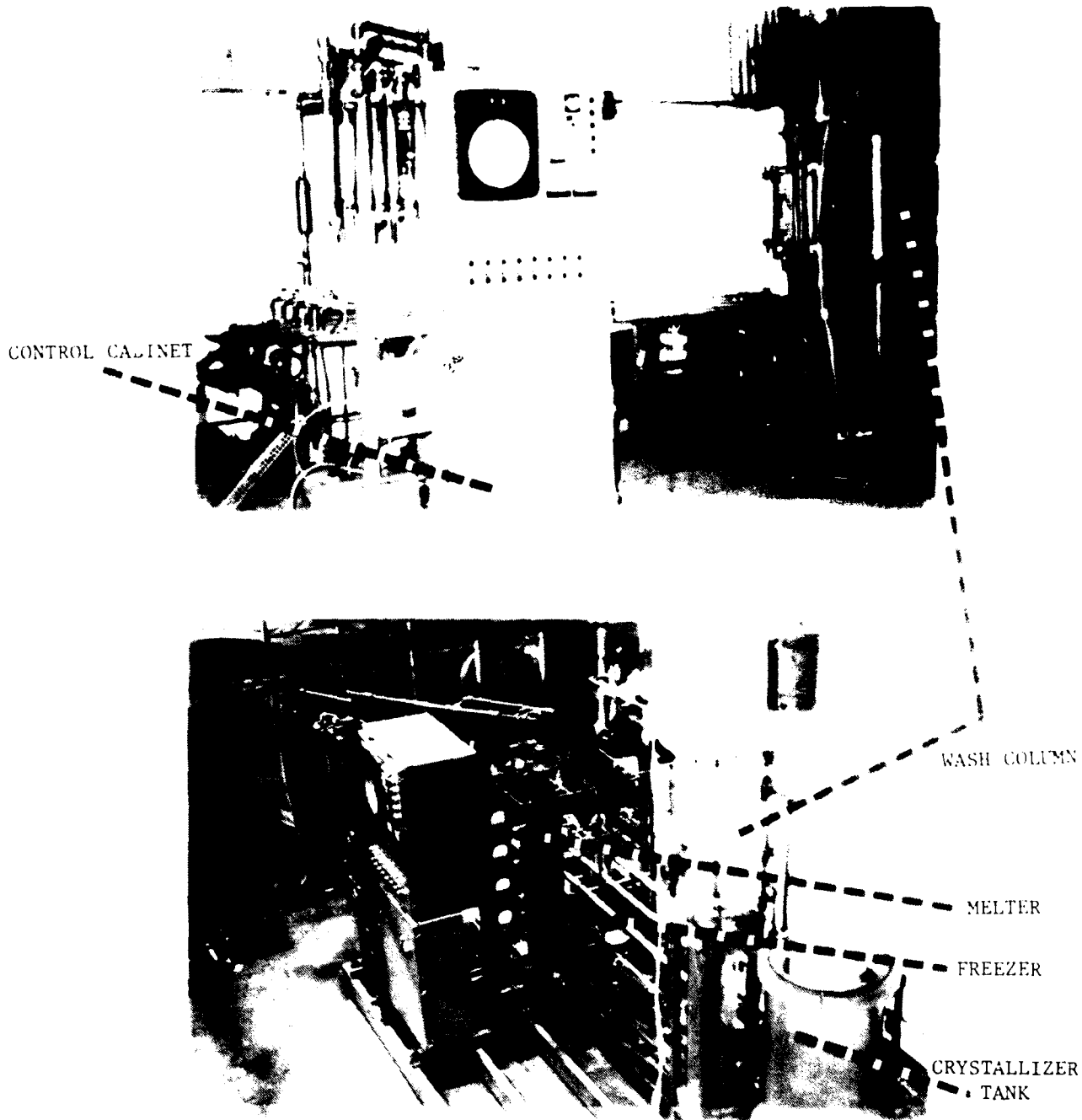

FIGURE 1 GENERAL PROCESS DIAGRAM



2



INDIRECT FREEZING LABORATORY PILOT PLANT

FIGURE 2

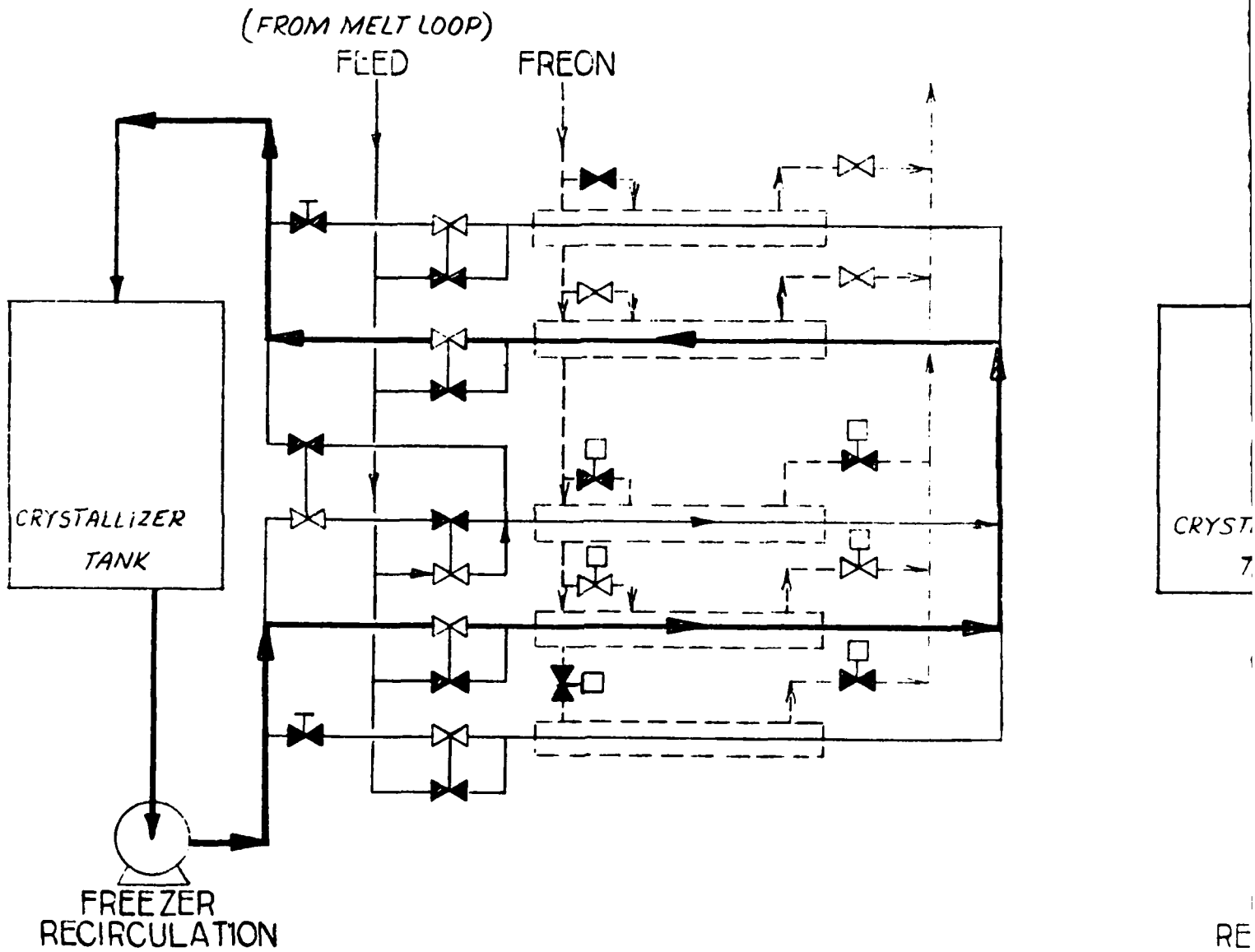
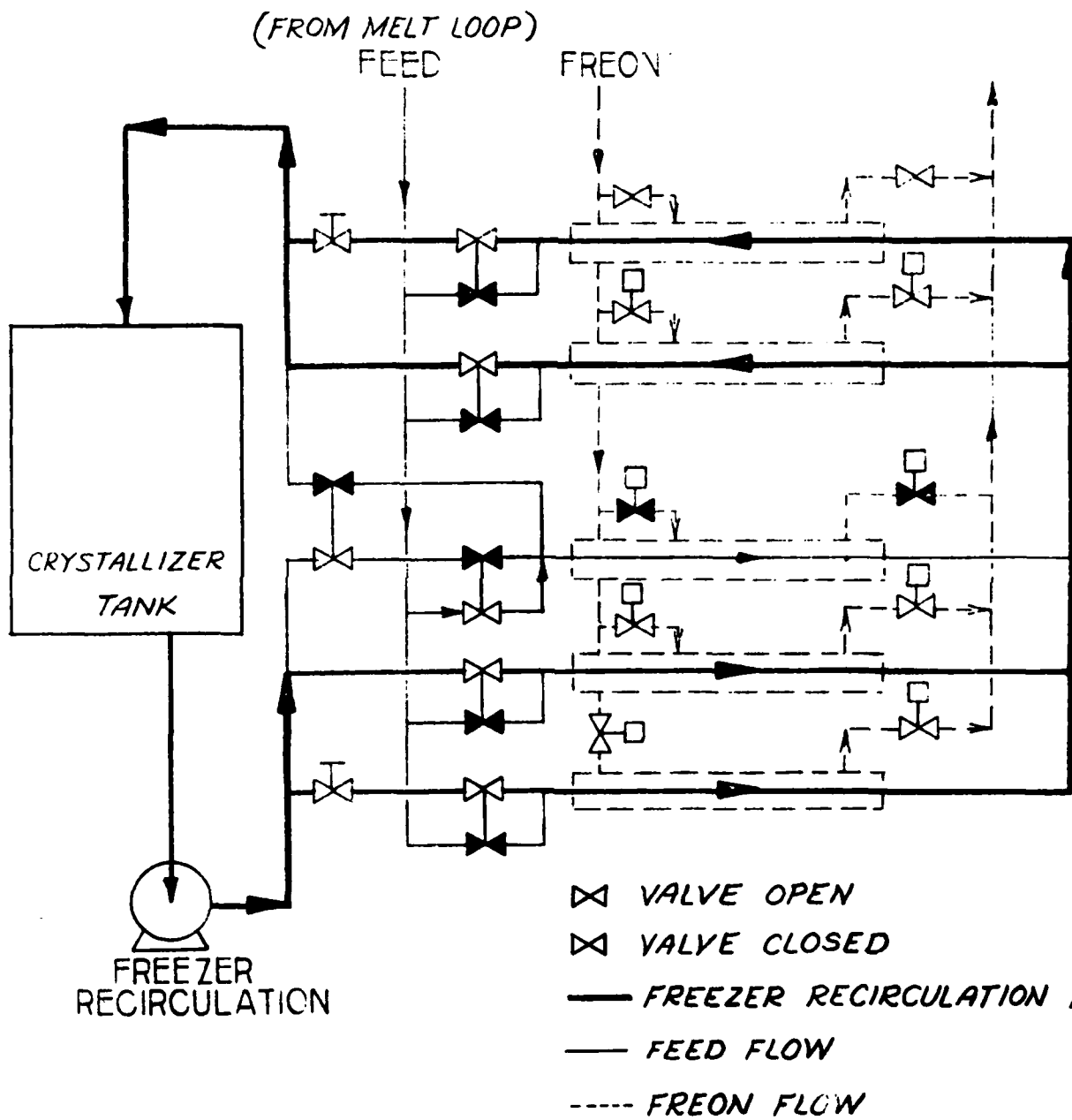

FIGURE 3 FREEZER FLOW SCHEMES FOR FREEZING WITH THREE AND FIVE TUBES



FREEZING

2

#### IV. EQUIPMENT DESCRIPTION

The entire freezing system, including control panel was mounted on a 7'x14' skid. A description of each major piece of equipment follows:

##### Freezer

The indirect freezer consists of five 10' long concentric tube heat exchangers. The outer tubes are made from 2" O.D. carbon steel tubing. The exterior is epoxy coated to prevent rust. The inner tubes are 1" O.D., type 316 stainless steel. The inside of each tube is polished to minimize nucleation sites and crystal growth on the tube. PVC air actuated ball valves are located at the brine inlet and outlet of the freezer. These valves are sequenced with refrigerant solenoid valves to provide defrosting of the freezer and different brine recirculating schemes through the freezer.

##### Crystal Growth Tank

The crystal growth tank is a vertically mounted cylindrical vessel, 15" I.D. x 32" high. The tank is constructed of transparent acrylic. An agitator is mounted at the top. Much of the top is open so that ice crystals from an external source can be added to seed the freezer.

##### Wash Column

The wash column is also constructed of transparent acrylic and is a vertically mounted cylindrical vessel 12" I.D. x 10' high. A 1" O.D. PVC tube is centered in the column and midway up, the tube becomes perforated. Concentrated brine solution is removed from the column and purged from the system through the perforated tube. The top of the column contains a mushroom shaped section where the ice is scraped over a ledge and mixed with a portion of the melt stream and slurried over to the melter.

##### Melter

The melter is a two pass heat exchanger. Both the tube and shell are constructed of type 316 stainless steel. The exchanger contains 180, 0.25" O.D. tubes and has a heat transfer area of 36.1 ft.<sup>2</sup>. Refrigerant gas is condensed in the shell and melts the ice as it is slurried through the exchanger tubes.

##### Heat Rejection Exchanger (Condenser)

Due to unavoidable inefficiencies in the system, the heat rejection exchanger is required to condense a portion of the refrigerant gas. The exchanger is a single pass unit with a brass shell and admiralty tubes. The heat transfer area is 80.8 ft.<sup>2</sup>. Tap water provides the cooling and the refrigerant is condensed on the shell side.

### Refrigeration System

The refrigeration system is a flooded or liquid recirculating system. Sufficient refrigerant liquid is maintained in the accumulator for forced recirculation through the freezer. A 316 stainless steel centrifugal pump serves as the refrigerant pump. Flow of liquid refrigerant through the freezer by gravity and natural convection is also possible. A float valve provides a liquid seal between the high and low pressure sides. A standard 5 hp reciprocating compressor is used to compress the refrigerant gas, Freon 22.

## V. INSTRUMENTATION

Thirteen thermocouples were used to measure temperature at important process locations. Temperature measuring points are shown in Figure 4. A data logger was used to record and accumulate the temperature data and a ice point thermocouple reference system was utilized to reference all channels to 32.0°F and prevent drift. Accuracy of the temperature measuring system was +0.1°C. Flow through the freezer was measured by a paddle wheel type flow indicator and a rotameter was used to measure feed flow.

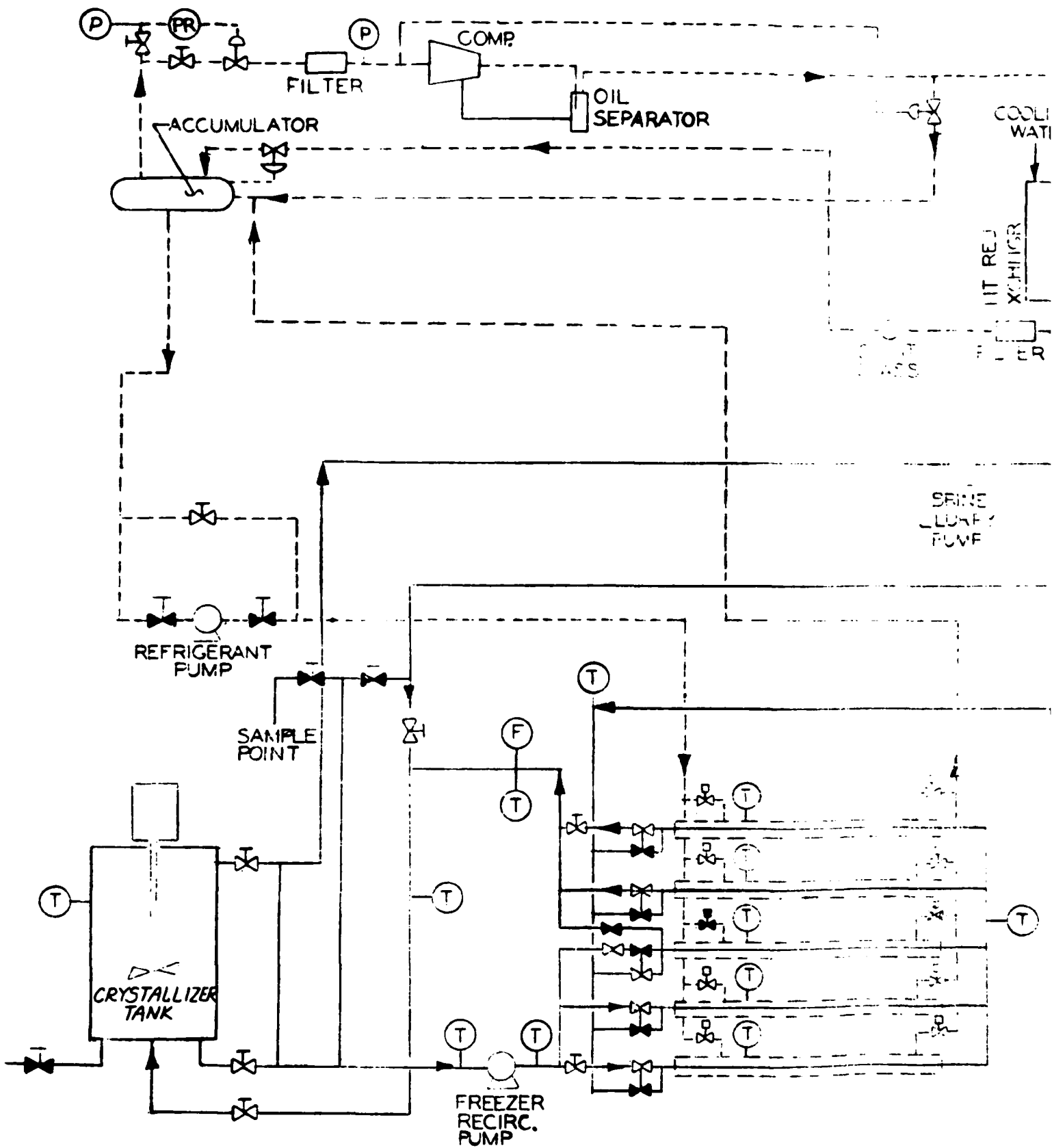
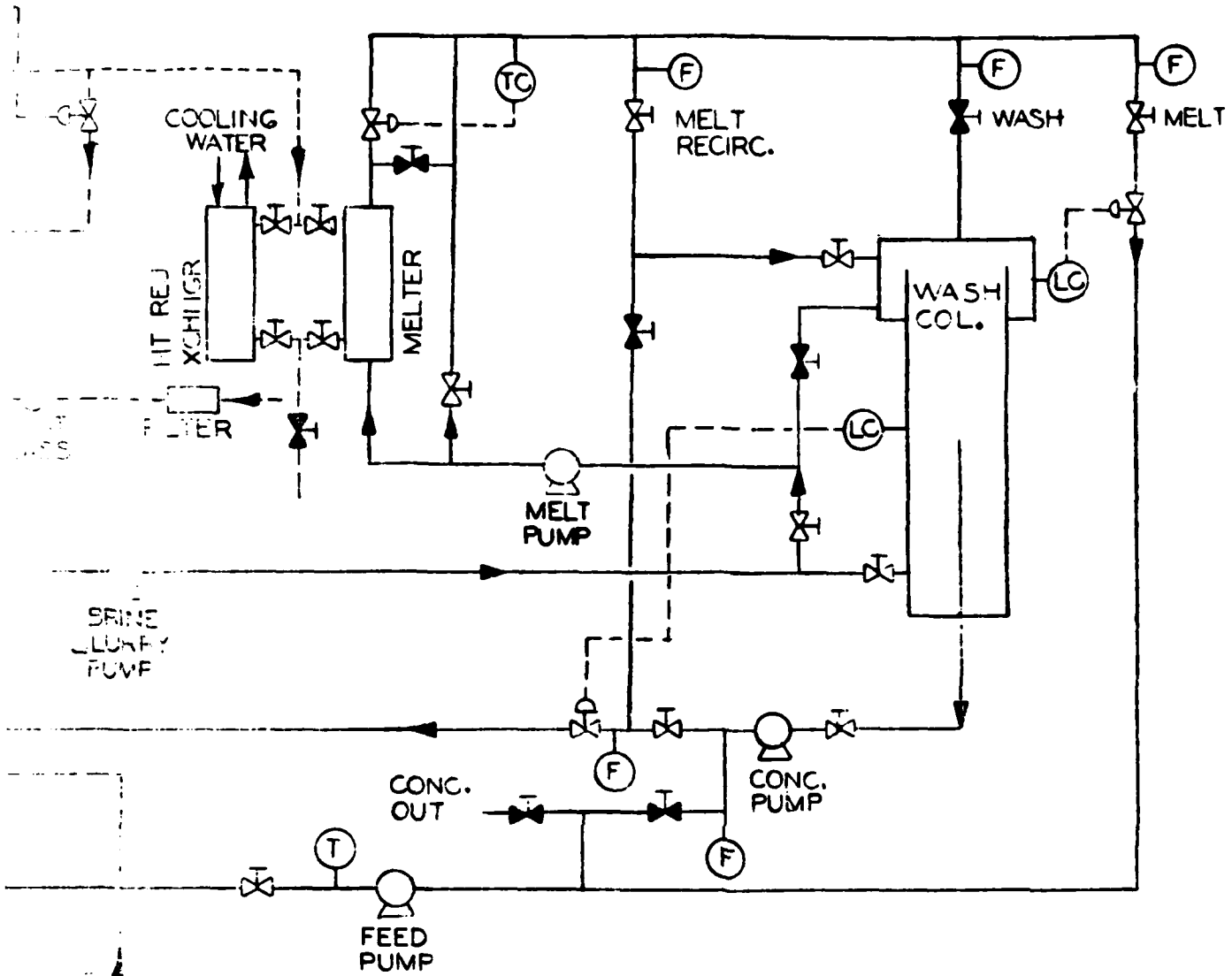

FIGURE 4

FLOW SCHEMATIC FOR EXPERIMENTAL RUNS  
500 GPD INDIRECT FREEZE PILOT PLANT



☒ VALVE OPEN                      — BRINE PIPING  
 ☒ VALVE CLOSED                  - - - REFRIGERATION PIPING

RUNS  
ANT

2

## VI. TESTS

### Defrost Cycle

Test Procedure - Tests were conducted to determine the defrost capability of the feed at design conditions (0.33 GPM and 1.7°C) and to define the most effective defrosting procedure for preventing the accumulation of ice on the heat transfer surfaces of the freezer.

The temperature of the refrigerant in the outer shell of each freezer tube was recorded as each tube was taken out of service and defrosted by the feed. Test conditions are summarized below:

1. Feed: 0.33 GPM at 1.7°C
2. Three tube freezer flow configuration (see Figure 3)
3. 0.84" I.D. freezer tubes

Results - Figure 5 is the temperature history for the refrigerant in each freezer tube as they were taken out of service and defrosted. The two curves on the right side of the graph indicated two solenoid valves leaked refrigerant into two of the tubes as they defrosted. These two solenoid valves were subsequently realigned during the test and the two tubes have since exhibited good defrost capability as shown by their respective curves on the left.

Discussion - From the tests we felt that ice removal from the heat transfer surfaces of the freezer would be accomplished when the refrigerant in each defrosting tube is warmed to slightly above the brine freezing point. This was confirmed in subsequent pilot plant runs not directly related to investigating the defrost process. In such runs, positive results were obtained only when defrosting in this manner. These runs were conducted under very favorable heat transfer conditions and crystal growth occurred in the bulk brine solution but ice did not accumulate on the heat transfer surfaces of the freezer. We determined that using a defrosting scheme that deviates more than slightly from the above procedure will not lead to successful operation of the freezer even under the most favorable heat transfer conditions.

Conclusions - A defrost cycle is required to prevent the accumulation of ice on the heat transfer surfaces of the freezer for successful operation. The most effective defrosting scheme was determined to be defrosting each tube separately until the Freon in the outer shell of the defrosting tube is warmed to slightly above the brine freezing point. At this point the defrosted tube is brought back into service and immediately another tube is taken out of service and defrosted.

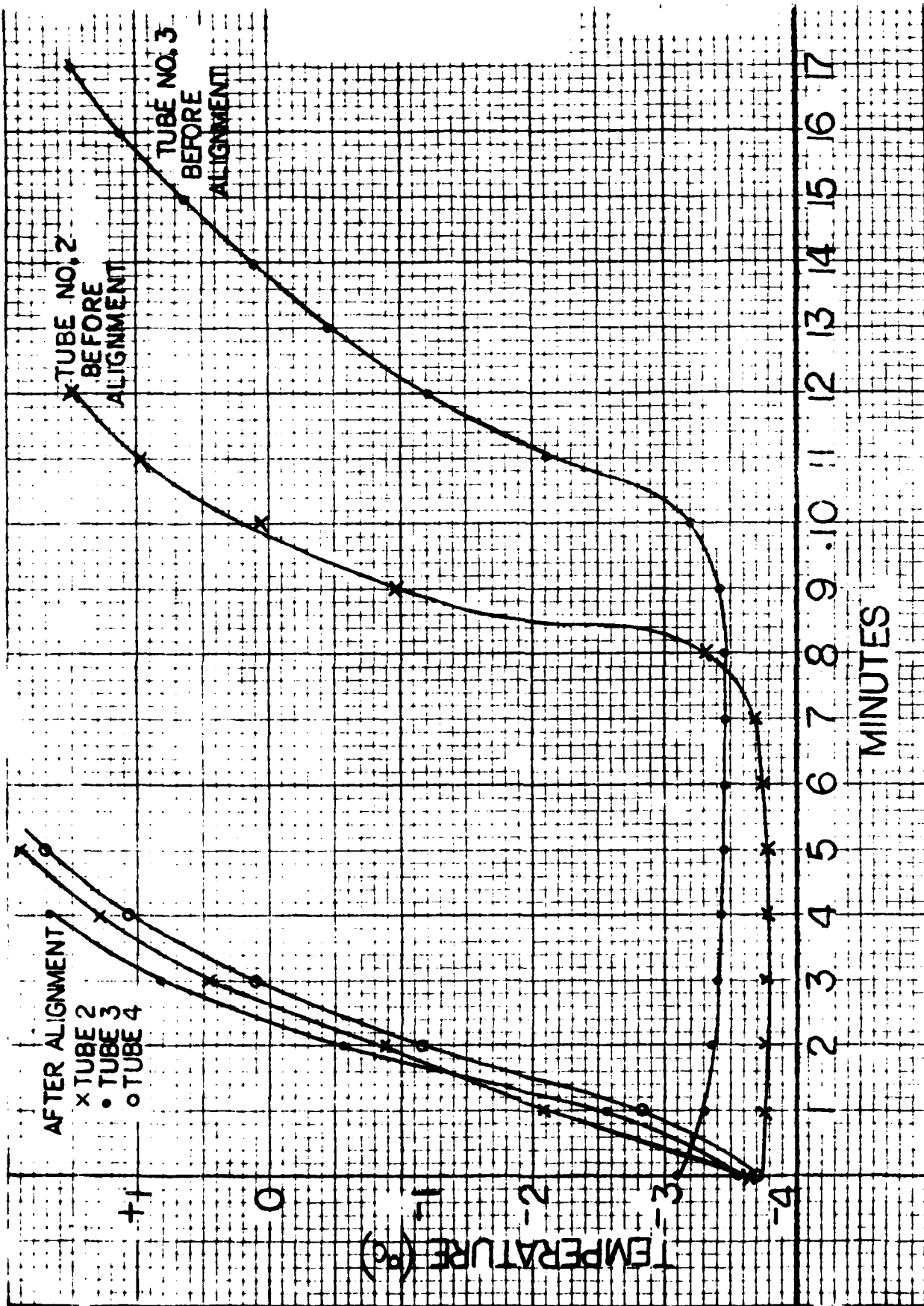

FREON TEMPERATURE IN REFRIGERATING TUBES

FIGURE 5

### Bulk Refrigerant Velocity

Test Procedure - Two types of refrigerant flow through the freezer shell are possible -- natural convection and forced circulation via a refrigerant pump. Both flow regimes were compared during runs in which the refrigerant pump was turned on for two hours, turned off for two hours and then turned on again. Test conditions are summarized below:

1. Refrigerant Velocity - natural convection/forced circulation
2. Brine Flow Velocity - 13.2 ft/sec
3.  $\Delta T$  between brine and refrigerant -  $6.6^{\circ}\text{C}$
4. Three tube flow configuration (see Figure 3)
5. .84 I.D. freezer tubes (no annulus)
6. Defrost cycle operation 2-3 min. per tube

Results - The refrigerant pump was observed to raise the pressure of the refrigerant in the freezer shell approximately 1 psi. (Thermocouple points were not located in the refrigerant side of the freezer so temperature was not measured at the time of the test.) All other freezing system data remained virtually unchanged and there was no detectable difference between having the refrigerant pump on or off. Large pieces of ice with the curvature of the tube wall appeared in the crystallizer tank on occasion after a freezer tube defrosted, but no substantial quantities of ice were produced. The brine effluent from the freezer remained approximately  $0.2^{\circ}\text{C}$  above the freezing point throughout the test after cool down.

Discussion - These large pieces of ice with the curvature of the tube wall indicated an insulating ice layer was forming inside the freezer tubes. We suspect that forced circulation of the refrigerant resulted in a larger outside heat transfer coefficient but most of this improved cooling capability resulted in just more ice layer formation on the freezer tube walls with no additional cooling of the brine. Further investigations with the refrigerant pump under conditions in which the insulating ice layer formation is minimized were not conducted because this condition was not determined until the very end of the testing program and no time was left for further experimentation. Also, leakage around the refrigerant pump was severe and all subsequent pilot plant runs were conducted with the refrigerant pump off.

Conclusions - The refrigerant pump was determined to provide no advantage under certain fluid flow conditions but further testing is warranted under conditions which minimize insulating ice layer formation on the freezer tube walls.

### Freezing with a Large Driving Force

Test Procedure - The temperature difference between brine and refrigerant was varied between 8.3-11.1°C for a 28 hour pilot plant run to determine the effect of operating with a large driving force. Test conditions are summarized below:

1.  $\Delta T$  between Brine and Refrigerant 8.3-11.1°C
2. Brine Flow Velocity - 13.2 ft/sec
3. Three Tube Flow Configuration (see Figure 3)
4. 0.84 I.D. Freezer Tubes
5. Defrost Cycle Operation 2-3 min. per tube

Results - In the beginning of the test, the brine temperature decreased very rapidly from room temperature (10°C) down to -1.0°C. At this point the brine temperature reached a steady state, fluctuating only 0.5°C even though the  $\Delta T$  varied from 9.3-11.0°C. Occasionally, small pieces of ice with the curvature of the tube wall appeared in the crystallizer tank after a freezer tube defrosted. A few hours into the test we noted that cooling water consumption for the refrigeration system was minimal and that the compressor discharge gas was being recycled back into the suction line of the compressor. Figure 6 is a temperature history of the brine effluent from the freezer for the 28 hour run.

Discussion - The large pieces of ice with the curvature of the tube wall indicated that an ice layer was forming inside the freezer tubes, although defrosting prevented total freeze-up. This ice layer acts as an insulation severely inhibiting the cooling capability of the freezer. Much of the compressor discharge gas by-passed the condensers and was recycled into the suction line because very little heat was removed by the freezer.

Conclusions - Large temperature differences between refrigerant and brine results in the formation of an ice layer on the heat transfer surfaces of the freezer severely inhibiting cooling capability. Negligible ice production results.

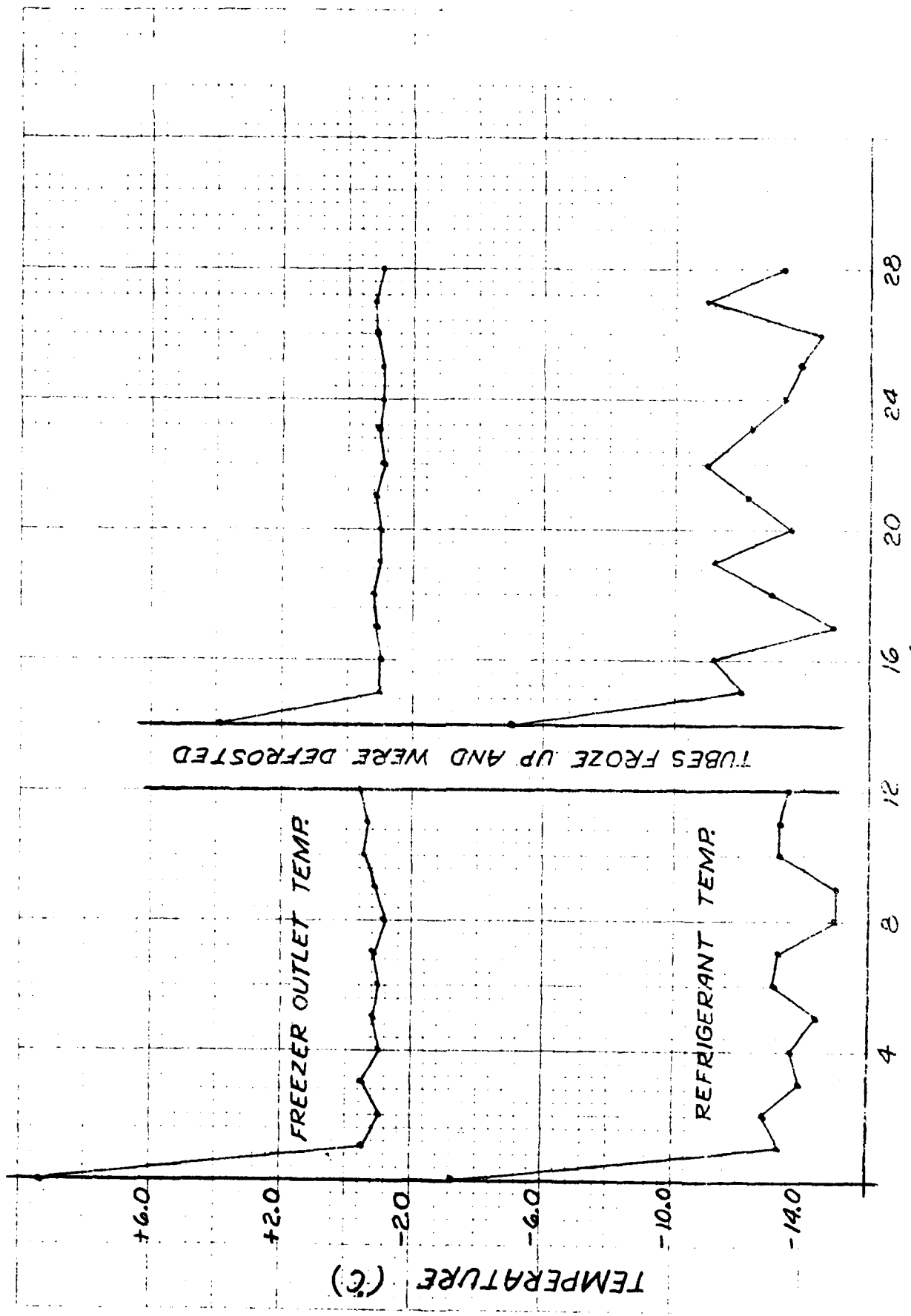

TEMPERATURE HISTORY FOR 28 HOUR RUN  
FIGURE 6

### Freezing with a Small Driving Force

Test Procedure - Various measures were taken to improve the tube side heat transfer coefficient such that a small driving force ( $\Delta T$ ) would be required for cooling and freezing. Data was collected under a variety of fluid flow and heat transfer conditions. For each test the refrigerant temperature was gradually lowered to cool the brine to the freezing point. The minimum temperature difference between brine and refrigerant required for cooling and freezing was maintained throughout each test. Test conditions and test results are summarized in Table 1.

Results - Schemes 4, 5 and 6 in Table 1 represented conditions under which nucleation and crystal growth occurred in the bulk brine solution when the flow schemes were coupled with an effective defrosting method. Figures 7, 8 and 9 are temperature histories for these tests.

In Scheme 4, nucleation and crystal growth occurred in the bulk brine solution in the freezer only once, for a brief time, at the beginning of the test. Crystal growth was so rapid that the flow through the freezer was almost completely obstructed by the newly formed ice material. After the crystals formed in the freezer, an insulating ice layer formed on the freezer tube walls as evidenced by the increased temperature difference between brine and refrigerant. Even though an effective defrosting scheme was used, crystal growth did not occur again in the bulk brine solution for the remaining part of the test. The temperature of the brine effluent from the freezer remained slightly above the freezing point. In Scheme 5, crystal growth occurred intermittently in the bulk brine solution in the freezer. Crystal growth was so rapid that the annular flow area in the freezer quickly plugged and flow through the freezer stopped completely. After 30-50 seconds of no flow, sufficient ice melted such that flow through the freezer resumed, and soft slush-like ice could be seen exiting the freezer. The brine solution cooled back down, and nucleation and crystal growth re-occurred in the bulk brine solution in the freezer, again blocking the freezer flow area. In this manner, the freezer produced ice intermittently throughout the remaining part of the test. Enough ice accumulated to cover the top of the crystallizer tank and small amounts were observed in the wash column. Scheme 6 resulted in the smallest cross sectional flow area in the freezer and when the brine solution nucleated in the freezer, plugging was severe. It was necessary to raise the refrigerant temperature a few degrees to melt the ice in the freezer so that flow could resume.

FREEZING SYSTEM DATA FOR DIFFERENT BRINE RECIRCULATION FLOW SCHEMES

TABLE 1

FLOW SCHEME	HYDRAULIC DIAMETER $D_h$	VELOCITY	REYNOLDS NUMBER	HEAT TRANSFER AREA	CALCULATED TUBE SIDE HEAT TRANSFER COEFFICIENT $h_i$ (1)	DRIVING FORCE ( $\Delta T$ BETWEEN BRINE AND REFRIGERANT)	HEAT REMOVAL AT NEAR FREEZING CONDITIONS (2)
#1 No Annulus 5 Tubes 4" Impeller	0.844	6.0 ft/sec	21,800	10.48 ft <sup>2</sup>	784 BTU/hr-ft <sup>2</sup> °F	6.8°C	N/A
#2 No Annulus 5 Tubes 5½" Impeller	0.844	10.9 ft/sec	39,700	10.48 ft <sup>2</sup>	1,260	6.5°C	N/A
#3 No Annulus 3 Tubes 4½" Impeller	0.844	13.2 ft/sec	48,000	5.24 ft <sup>2</sup>	1,470	6.6°C	N/A
#4 No Annulus 3 Tubes 5½" Impeller	0.844	18.9 ft/sec	68,900	5.24 ft <sup>2</sup>	1,970	4.6°C	152-181 BTU/Min
#5 Annulus 3 Tubes 5½" Impeller	0.304	17.0 ft/sec	22,300	5.24 ft <sup>2</sup>	2,210	4.2°C	166-219 BTU/Min
#6 Annulus 3 Tubes 5½" Impeller	0.169	15.9 ft/sec	11,600	5.24 ft <sup>2</sup>	2,360	3.3°C	185-230 BTU/Min

(1)  $h_i = 0.023 Re^{0.8} Pr^{0.33} \frac{k}{D_h}$

(2) Determined from inlet and outlet temperature of freezer during cool-down and flow rate through freezer

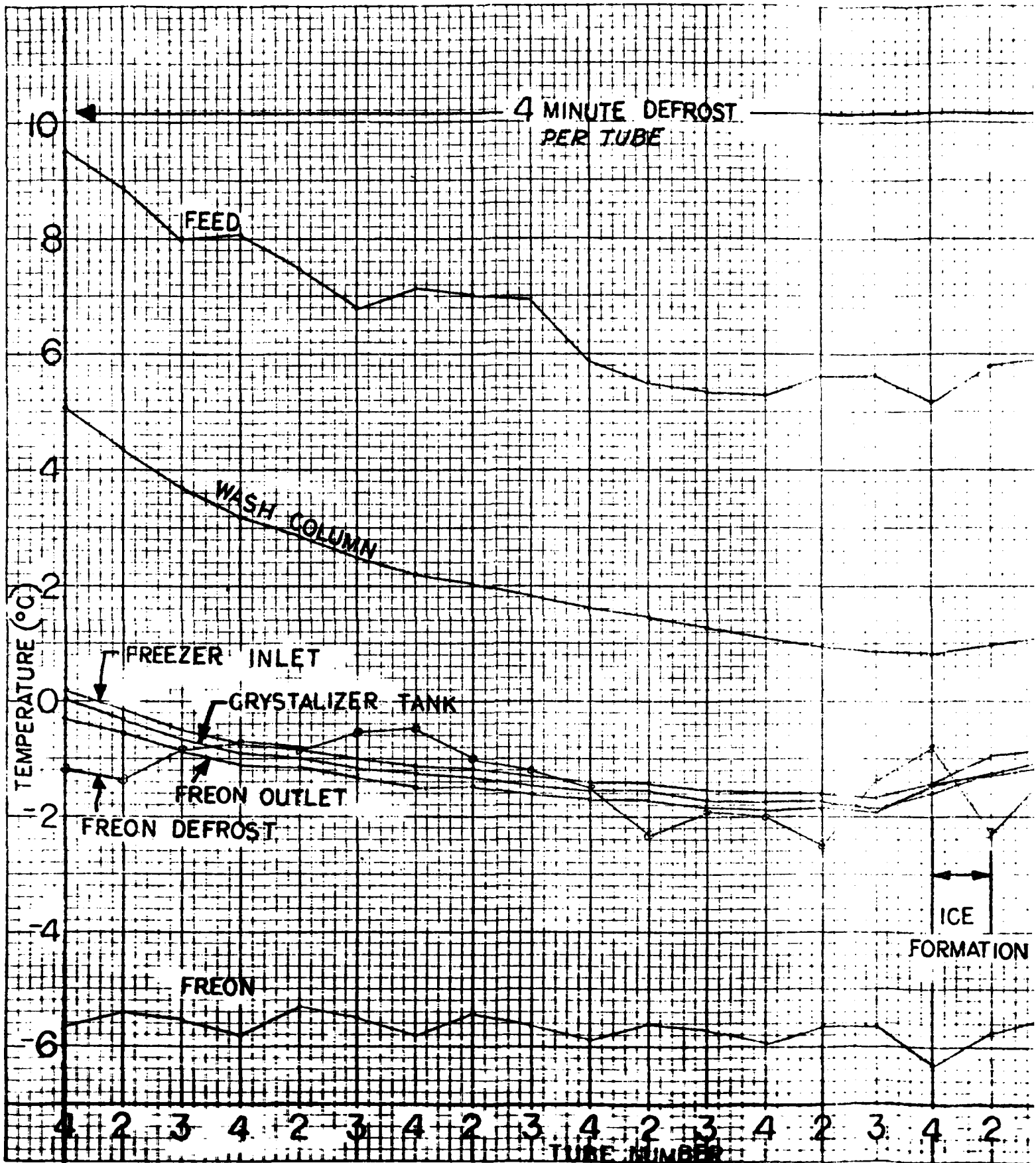
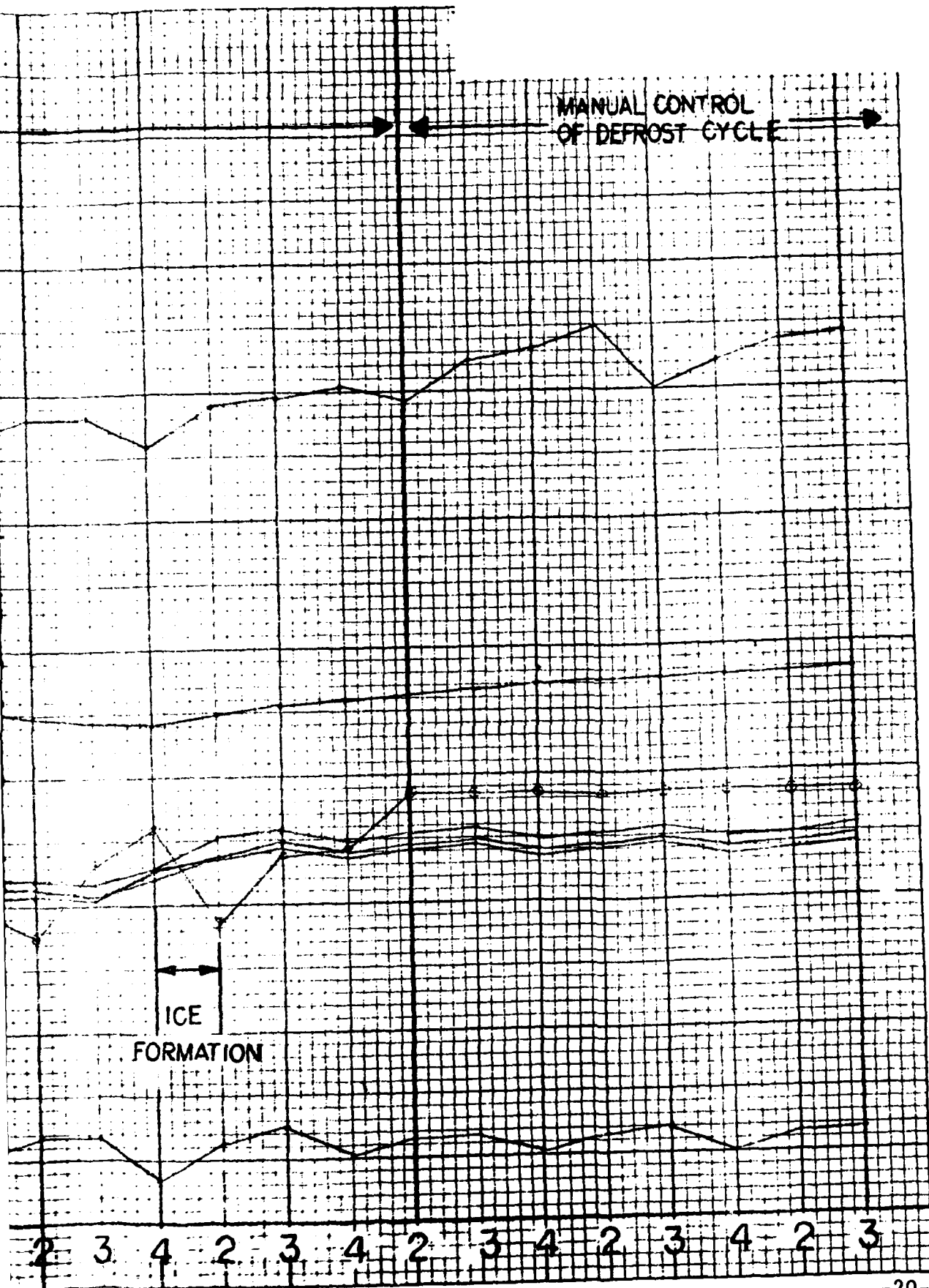

FIGURE 7 TEMPERATURE DATA RECORDED AFTER EACH TUBE DEFROST  
SCHEME 4 (NO ANNULUS)



1 TUBE DEFROSTED

2

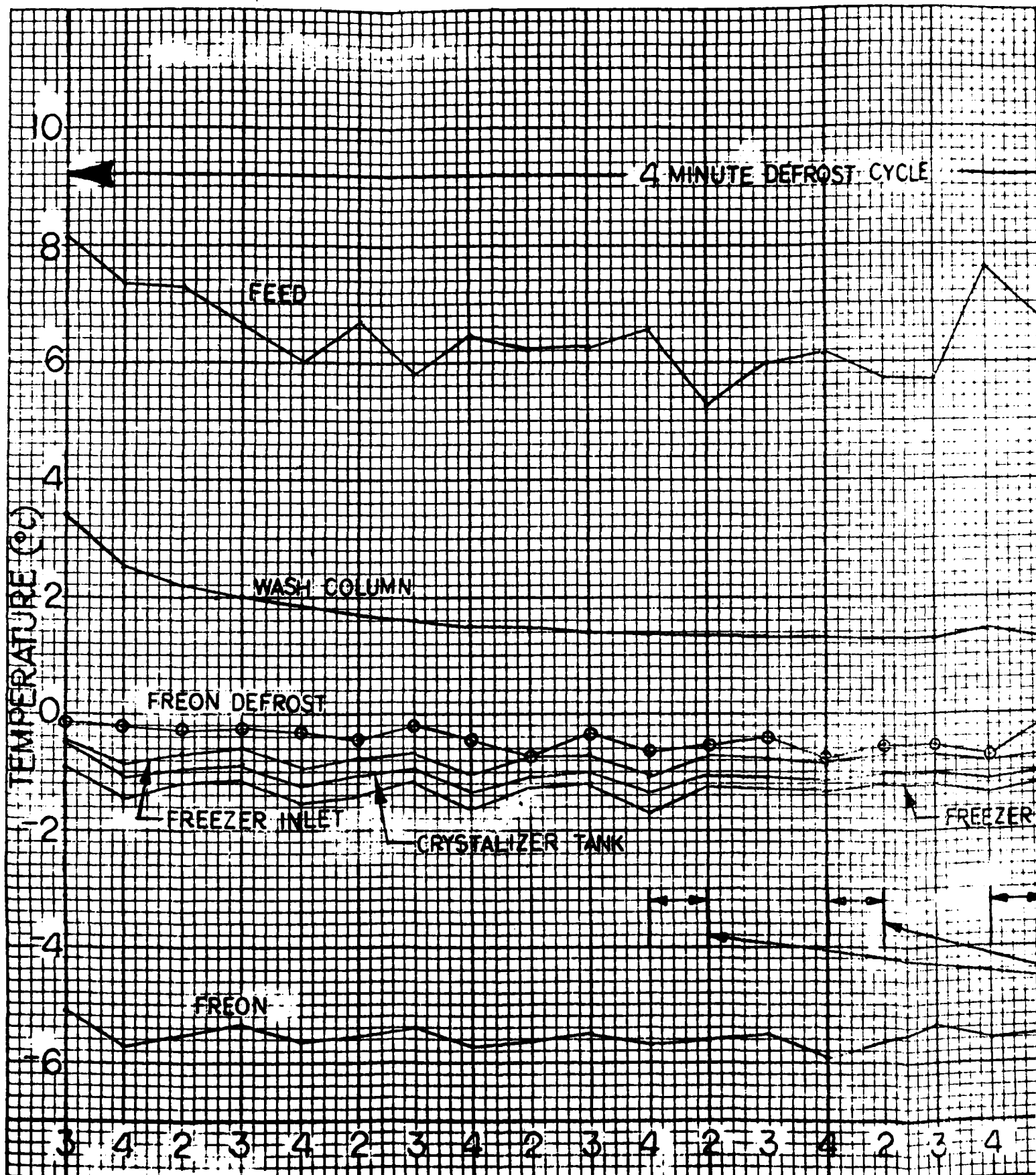
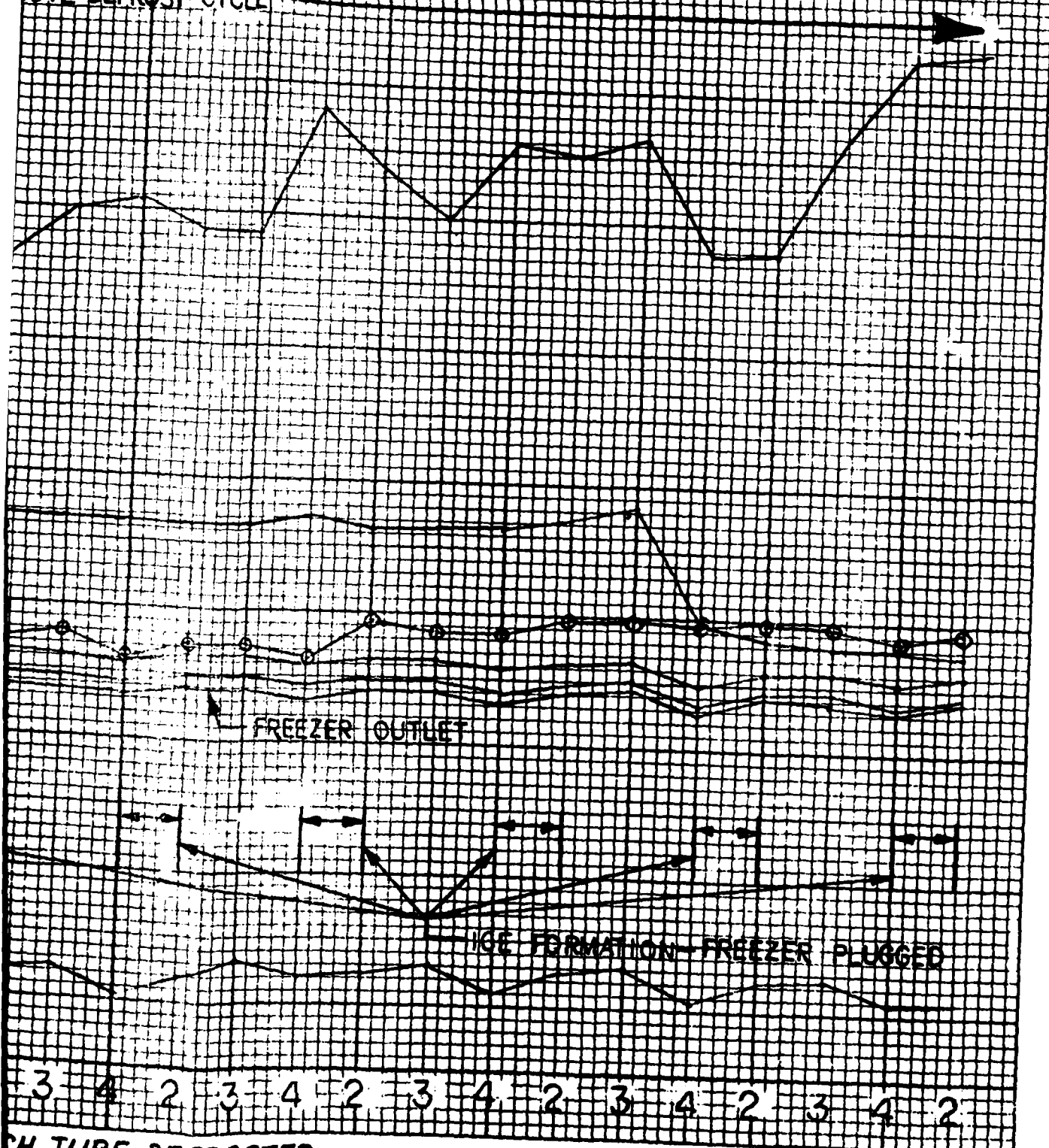

FIGURE 8 TEMPERATURE DATA RECORDED AFTER EACH TUBE DEFROSTED  
 SCHEME 5 ( $D_h = 0.304$  IN.)

UTE DEFROST CYCLE



SH TUBE DEFROSTED

2

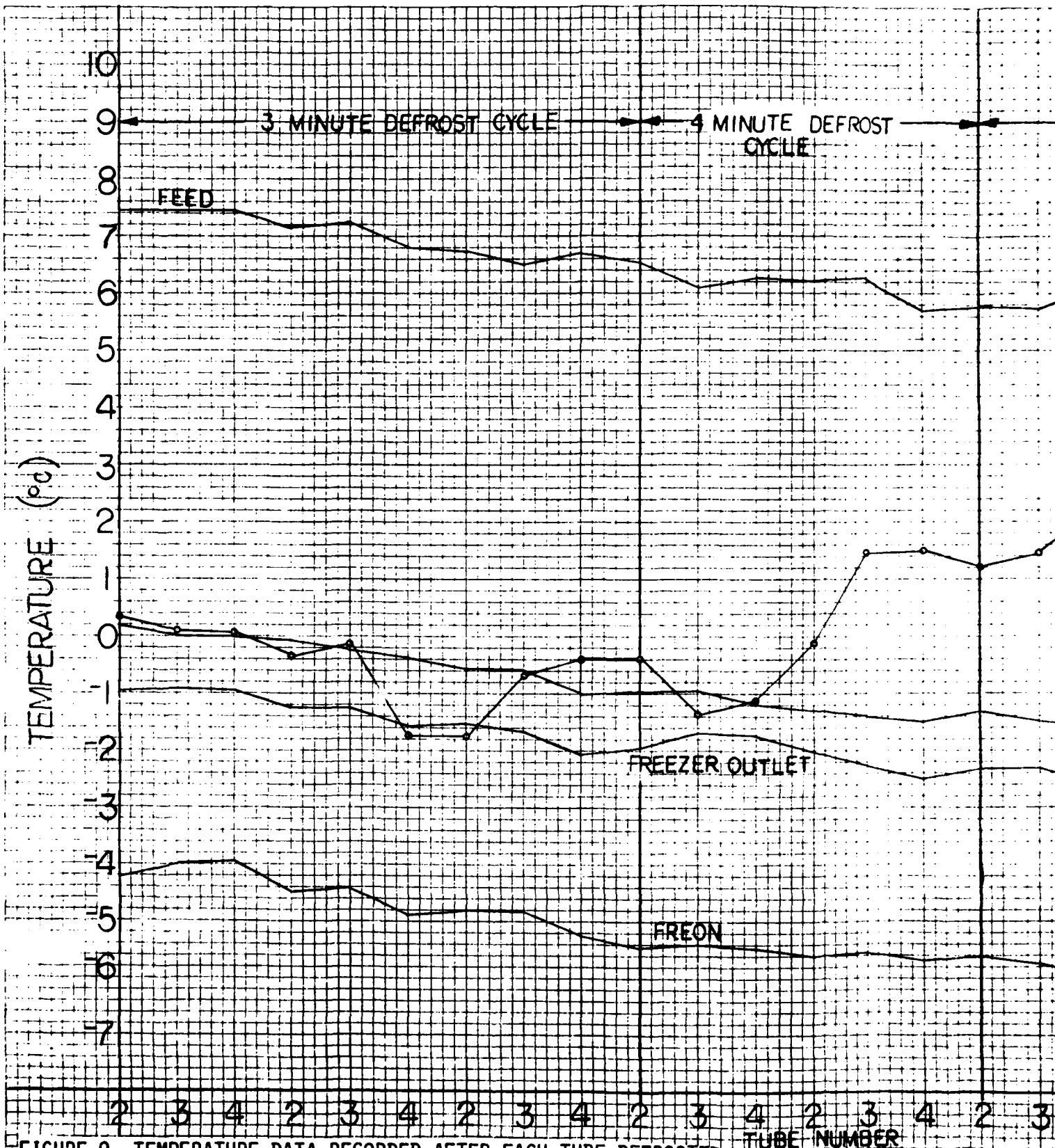
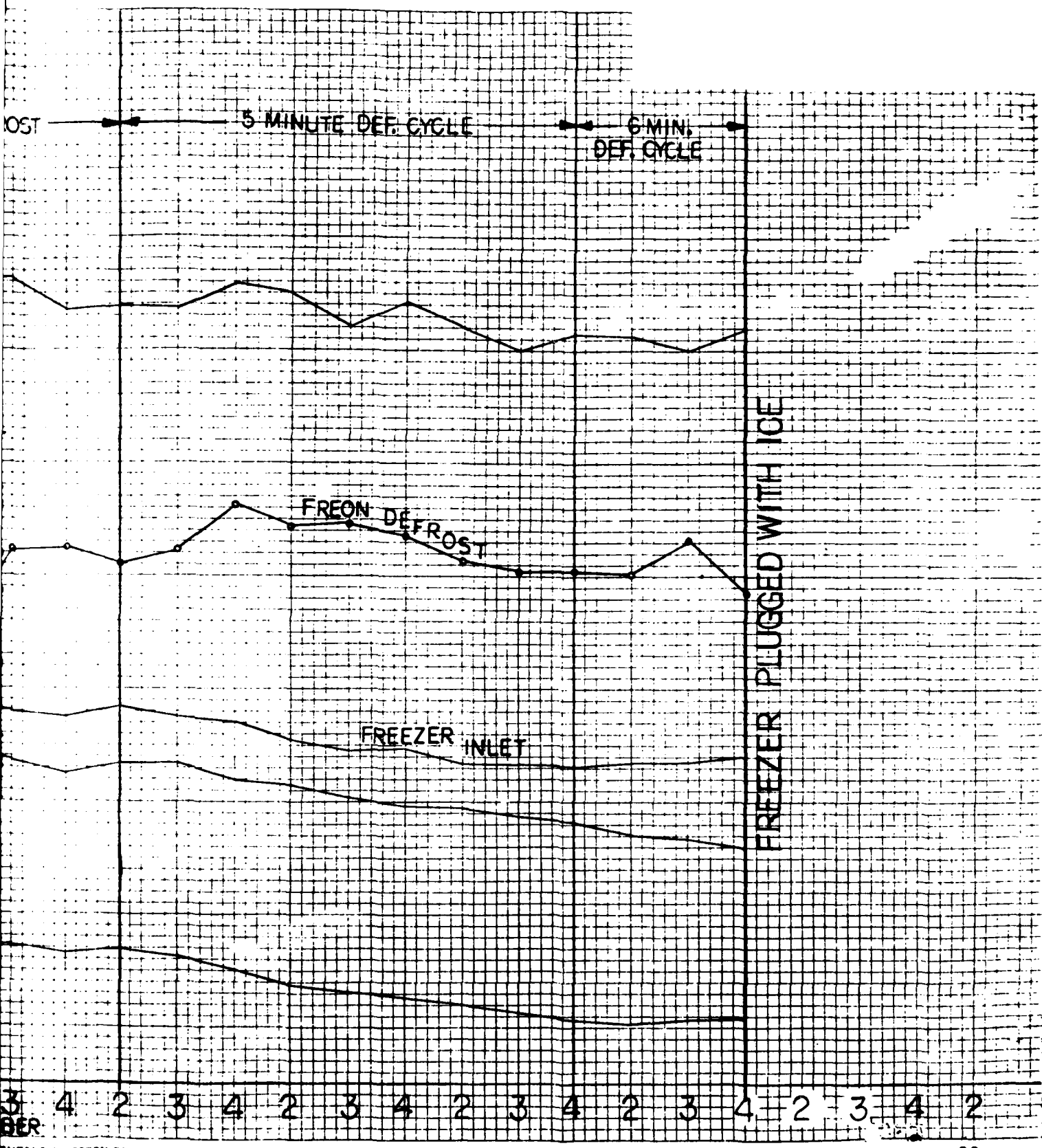

FIGURE 9 TEMPERATURE DATA RECORDED AFTER EACH TUBE DEFROSTED

EUGENE DIETZGEN CO.



2

Discussion - Various brine flow schemes through the freezer were used to obtain the above results and reach the point of successful testing. The tests were performed using combinations of the following conditions:

1. Freezing with three and five tubes (heat transfer area = 5.24 ft.<sup>2</sup> and 10.48 ft.<sup>2</sup> as shown in Figure 3)
2. Using a 4½ in. and 5½ in. impeller in the freezer recirculating pump
3. Recirculating brine through the freezer through 0.84 I.D. tubes and through two annular spaces.

The annular configuration was achieved by inserting PVC volume displacer rods in the center of the existing stainless steel freezer tubes. The volume displacer rods were fabricated out of ½ in. and 3/8 in. PVC pipe. The ends of the pipe were plugged and PVC beads were welded longitudinally along the outside of the pipe to center the displacer rods inside the freezer. It was not possible to measure the heat transfer coefficient for the brine side of the freezer, but a reasonable estimate of it can be made from the freezer geometry, flow velocity and fluid properties by using the Sieder Tate equation:

$$h_i = 0.023 Re^{0.8} Pr^{0.33} \frac{k}{D_h}$$

As shown in Table 1, for the geometry and flow conditions tested, the heat transfer coefficient was calculated to be highest with the smallest flow area, while turbulence (i.e. Reynolds Number) was highest with the largest flow area and highest velocity.

Conclusions - The most positive results were obtained with the highest tube side heat transfer coefficients even under less turbulent conditions; more heat was removed by the freezer even with less driving force. Data in Table 1 supports these conclusions. At tube side coefficients greater than 1970 (by calculation) nucleation and crystal growth begins to occur in the bulk brine solution in the freezer, when an effective defrosting scheme is used. The mechanical or shearing action of turbulence up to Reynolds Numbers of 60,000 was ineffective in removing or preventing ice layer formation on the freezer tube walls. An effective defrosting scheme is required to prevent ice accumulation on the heat transfer surfaces of the freezer no matter how favorable the heat transfer conditions.

BTU  
hr-ft<sup>2</sup>-°F

### Seeding Experiments

Test Procedure - For seeding experiments, the freezing system was run with the crystallizer tank one-half full of brine solution. When the brine solution (6.2%) in the tank was within 1.0°C of the freezing point, natural snow was added until the entire crystallizer tank was full of a thick slurry solution. This slurry was circulated through the freezer. A three minute per tube defrost cycle was used for each test. Seeding experiments were conducted as stated above for the following freezer flow schemes:

- Case 1: 0.84 I.D. freezer tubes  
brine flow velocity before seeding - 18.9 ft/sec  
three tube flow configuration (see Figure 3)  
 $\Delta T$  between brine and refrigerant - 4.6°C
- Case 2: annular flow -  $D_h = 0.30$   
brine flow velocity before seeding 17.0 ft/sec  
three tube flow configuration (see Figure 3)  
 $\Delta T$  between brine and refrigerant 4.2°C
- Case 3: annular flow  $D_h = 0.17$   
brine flow velocity before seeding 15.9 ft/sec  
three tube flow configuration (see Figure 3)  
 $\Delta T$  between brine and refrigerant 3.3°C

Results - For the first two cases, crystal growth occurred to a limited extent on the seed (ice) crystals as they passed through the freezer. The snow melted faster than the production of ice and after two hours no ice was left in the system. For Case 3, with the smallest annular space, the freezer flow area readily plugged with ice and slurry could only be circulated for brief times before flow through the freezer stopped completely.

Discussion - It was hypothesized that the ice crystals, as they circulated through the freezer, would compete with the tube walls as nucleation sites and crystal growth would occur on the crystals themselves. This was observed in the tests to a very limited extent. Some of the seed or ice crystals were returned to the crystallizer with a white edge on them and this is what we concluded to be crystal growth on the seed crystals themselves.

Conclusions - Crystal growth occurs on seed (ice) crystals as they are circulated through the freezer but to a very limited extent for the flow conditions tested. Testing at more favorable conditions (e.g. higher recirculation rates) is beyond the capabilities of the equipment.

## VII. RECOMMENDATIONS

This investigation indicates that further development work is required before a smooth tube indirect freezer can be incorporated in a freeze desalination unit. Further testing is recommended to determine the full potential of indirect freezing since positive test results were obtained at the conclusion of the program. The last week of testing indicated that soft, fine ice, similar to that produced in direct contact processes could be produced on an intermittent basis. This ice plugged the freezer rather than freezing as a solid, hard mass. No time was left in the program to deal with this problem although a solution appears likely. One approach would be to develop a method continuously removing this soft ice from the freezer. The ice plugged the 0.84 I.D. freezer tubes for only brief periods of time (30-50 sec.). A freezer recirculation pump with a higher discharge pressure may be all that is required to continuously remove the ice and maintain flow. Another approach would be to subcool in the freezer and avoid nucleation in the freezer tubes. Installation of an ice strainer in the bottom of the crystallizer tank to eliminate the recirculation of all ice nuclei through the freezer might encourage subcooling in the freezer and restrict crystal growth to the crystallizer tank.