

AD-A085 707

AIR FORCE INST OF TECH WRIGHT-PATTERSON AFB OH SCHOO--ETC P/8 20/5  
COMPARISON OF CONTROL METHODS IN A FREQUENCY STABILIZED LASER. (11)  
JAN 80 R D LUZITANO  
AFIT/8E/EE/80-2

UNCLASSIFIED

ML

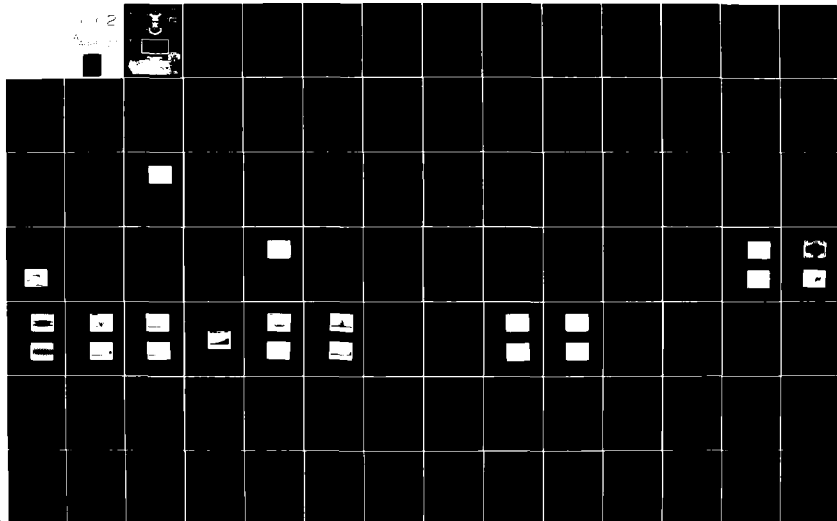

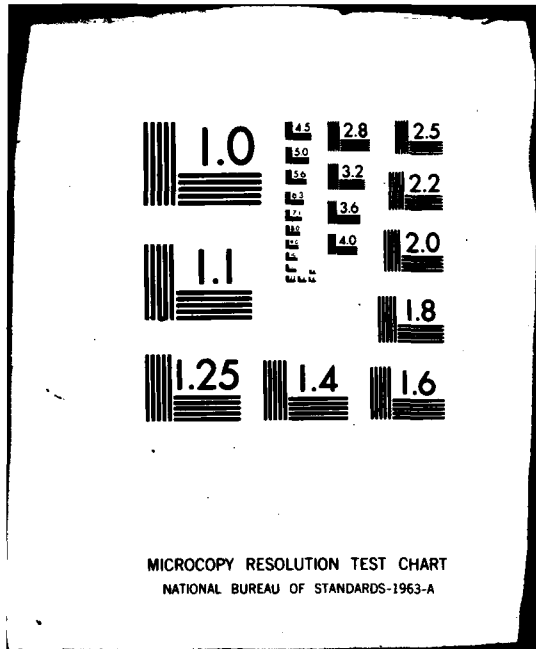

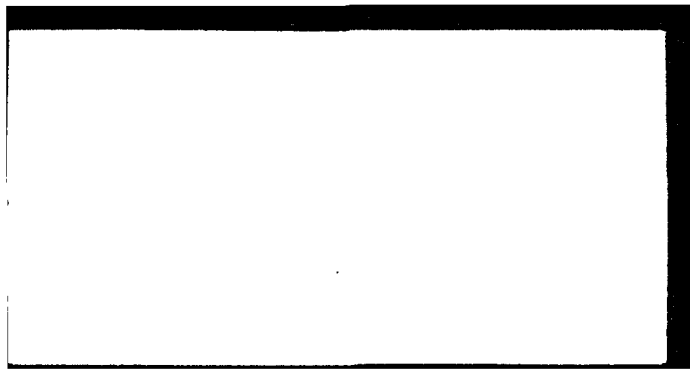

COMPARISON OF CONTROL METHODS IN A  
FREQUENCY STABILIZED LASER

THESIS

AFIT/GE/EE/80-2      Robert D. Luzitanc  
                                 Capt                                      USAF

JUN 19 1980

A

Approved for public release; distribution unlimited.

COMPARISON OF CONTROL METHODS IN A  
FREQUENCY STABILIZED LASER

THESIS

Presented to the Faculty of the School of Engineering ✓  
of the Air Force Institute of Technology

Air University

in Partial Fulfillment of the  
Requirements for the Degree of  
Master of Science

by

Robert D. Luzitano, B.S.  
Capt USAF  
Graduate Electrical Engineering  
January 1980

Approved for	
Dist	Special
A	

Approved for public release; distribution unlimited.

## Preface

The purpose of this thesis is to compare two different types of control methods that can be used to frequency stabilize a laser. This study should help solve some of the problems associated with the passive ring laser gyro work being done in the Navigation Laboratory at the Air Force Institute of Technology (AFIT).

My thanks are extended to Major Salvatore Balsamo for suggesting this area of research to me and for providing me with the necessary background knowledge and guidance during my studies. I also thank Dr. Kent Stowell of the Avionics Laboratory for sponsoring this thesis and for providing me with much of the equipment required during my research. In addition, special gratitude is extended to Mr. Carl Shortt and his personnel of the Model Fabrication Shop, and to Mr. Robert Durham and his personnel of the AFIT Electrical Engineering Laboratory for providing me with the fabricated components and technical expertise required during my research work. Finally, I thank my wife and family for their help, understanding, and devotion during this period.

Table of Contents

	Page
Preface .....	ii
List of Figures .....	v
List of Tables .....	x
List of Symbols .....	xi
Abstract .....	xvi
I Introduction .....	1
Background .....	1
Problem Statement .....	4
Method of Approach .....	4
Order of Presentation .....	5
II Frequency Stabilization .....	7
General Description .....	7
Fabry-Perot Interferometer .....	8
Control Method I .....	11
Control Method II .....	14
Modulation Technique .....	16
Compensators .....	20
III Laser Design .....	22
General Description .....	22
Laser Gain Tube .....	22
Laser Mirrors .....	24
Piezoelectric Transducer .....	25
End Plate Spacer Bars .....	25
Axial Mode Spacing .....	26
IV Laser Noise Sources .....	28
General Discussion .....	28
Laser Noise Due to Temperature Change .....	28
Laser Noise Due to Acoustical Noise and Table Vibrations .....	31
Laser Noise from the Gain Tube .....	32
Noise from the Control Loop .....	33
V System Model Parameters and Transfer Functions .....	43
General Discussion .....	43
Interferometer Sensitivity ( $\Delta v_I$ ) .....	43
PZT <sub>1</sub> Sensitivity ( $\Delta v_{PZT1}$ ) .....	44
PZT <sub>2</sub> Sensitivity ( $\Delta v_{PZT2}$ ) .....	47
LIA Constant (K <sub>LIA</sub> ) .....	47
LIA Frequency Analysis and Transfer Function .....	50

	Page
HVA <sub>1</sub> /PZT <sub>1</sub> Frequency Analysis and Transfer Function .....	52
HVA <sub>2</sub> /PZT <sub>2</sub> Frequency Analysis and Transfer Function .....	54
VI Compensator Design .....	57
General Discussion .....	57
Compensator Gc <sub>1</sub> for Variation 1 of Control Method I Using Steady State Analysis .....	57
Compensator Gc <sub>2</sub> for Variation 2 of Control Method I Using Frequency Analysis .....	65
Compensator Gc <sub>3</sub> for Control Method II Using Frequency Analysis .....	71
Final Design of Each Compensator ...	74
VII Performance Comparisons .....	79
General Discussion .....	79
Control Range Comparisons .....	79
Frequency Spectrum of the LIA Error Signal .....	83
VIII Conclusions and Recommendations .....	91
General Discussion .....	91
Conclusions .....	91
Recommendations .....	92
Bibliography .....	94
Appendix A: Laser/Interferometer Hardware Designs .....	95
Appendix B: Circuit Design and Tests of Compensator Gc <sub>1</sub> .....	100
Appendix C: Circuit Design and Tests of Compensator Gc <sub>2</sub> .....	105
Appendix D: Circuit Design and Tests of Compensator Gc <sub>3</sub> .....	110
Appendix E: Experimental Procedure .....	117
Appendix F: Equipment Listing .....	119
Vita .....	120

List of Figures

Figure		Page
1.1	Relationship Between a Laser Transition Curve, Axial Mode Spacing, and Laser Output Intensity .....	3
2.0	Laser Output Scanned with the Reference Interferometer .....	11
2.1	Control Loop Block Diagram for Control Method I .....	12
2.2	Control Loop Model for Control Method I ...	12
2.3	Control Loop Block Diagram for Control Method II .....	15
2.4	Control Loop Model for Control Method II ..	15
2.5	Interferometer Intensity vs Laser Frequency .....	17
2.6	LIA Phase Comparison A .....	17
2.7	LIA Phase Comparison B .....	18
2.8	LIA Phase Comparison C .....	18
3.1	Laser Design .....	23
3.2	Assembled Laser with Interferometer .....	23
3.3	Laser Output Scanned with the Reference Interferometer for FSR Calculations .....	27
4.1	Noise from Interferometer Power Supply ....	35
4.2	Noise from the Detector with the Laser Blocked .....	35
4.3	Noise from LIA .....	36
4.4	Noise from HVA <sub>1</sub> .....	36
4.5	Noise from HVA <sub>2</sub> .....	37
4.6	Spectral Content of the noise from the Interferometer Power Supply .....	38

List of Figures

Figure		Page
4.7	Spectral Content of Detector Noise with the Laser Blocked .....	39
4.8	Spectral Content of Noise from the LIA .....	40
4.9	Spectral Content of HVA <sub>1</sub> Noise .....	41
4.10	Spectral Content of HVA <sub>2</sub> Noise .....	42
5.1	Block Diagram of Interferometer Sensitivity Test .....	44
5.2	PZT <sub>1</sub> Sensitivity .....	45
5.3	PZT <sub>2</sub> Sensitivity .....	46
5.4	Block Diagram of the Test Scheme to Determine the LIA Constant .....	48
5.5	Results of Laser Scan for Determination of LIA Constant .....	49
5.6	Block Diagram of Equipment Scheme used to Determine LIA Frequency Characteristics ...	50
5.7	LIA Frequency Response Results .....	51
5.8	Frequency Analysis of HVA <sub>1</sub> /PZT <sub>1</sub> Combination Using A Condenser Microphone .....	52
5.9	HVA <sub>1</sub> /PZT <sub>1</sub> Frequency Response Results .....	53
5.10	HVA <sub>2</sub> /PZT <sub>2</sub> Frequency Response Results .....	54
6.1	System Model for Control Method I with Transfer Functions .....	58
6.2	System Model for Control Method II with Transfer Functions .....	58
6.3	System Root Locus. Variation I of Control Method I Using Compensator Gc <sub>1</sub> .....	62

List of Figures

Figure		Page
6.4	Open Loop Frequency Response. Variation 1 of Control Method I Using Compensator Gc <sub>2</sub> .....	63
6.5	Closed Loop Frequency Response. Variation 1 of Method I Using Gc <sub>1</sub> .....	64
6.6	System Root Locus. Variation 2 of Control Method I Using Compensator Gc <sub>2</sub> .....	68
6.7	Open Loop Frequency Response. Variation 2 of Control Method I Using Gc <sub>2</sub> .....	69
6.8	Closed Loop Frequency Response. Variation 2 of Control Method I Using Gc <sub>2</sub> .....	70
6.9	System Root Locus. Control Method II Using Compensator Gc <sub>3</sub> .....	75
6.10	Open Loop Frequency Response. Control Method II Using Compensator Gc <sub>3</sub> .....	76
6.11	Closed Loop Frequency Response. Control Method II Using Compensator Gc <sub>3</sub> .....	77
6.12	Final Compensator Designs .....	78
7.1	Dynamic Range. Method I, Variation 2, Using Compensator Gc <sub>2</sub> .....	80
7.2	Dynamic Range. Method II Using Compensator Gc <sub>2</sub> .....	81
7.3	Spectral Content of the Open Loop Error Signal (0 Hz - 250 Hz) .....	86
7.4	Spectral Content of the Open Loop Error Signal (0 Hz - 2 KHz) .....	86
7.5	Spectral Content of the Closed Loop Error Signal (0 Hz - 250 Hz); Method I, Variation 1 .....	87
7.6	Spectral Content of the Closed Loop Error Signal (0 Hz - 250 Hz); Method I, Variation 2 .....	87

List of Figures

Figure		Page
7.7	Spectral Content of the Closed Loop Error Signal (0 Hz - 250 Hz) Using the Gc <sub>3a</sub> Portion of Compensator Gc <sub>3</sub> .....	88
7.8	Spectral Content of the Closed Loop Error Signal (0 Hz - 250 Hz); Method II .....	88
7.9	Spectral Content of the Closed Loop Error Signal (0 Hz - 2 KHz); Method I, Variation 1 .....	89
7.10	Spectral Content of the Closed Loop Error Signal (0 Hz - 2 KHz); Method I, Variation 2 .....	89
7.11	Spectral Content of the Closed Loop Error Signal (0 Hz - 2 KHz) Using the Gc <sub>3a</sub> Portion of Compensator Gc <sub>3</sub> .....	90
7.12	Spectral Content of the Closed Loop Error Signal (0 Hz - 2 KHz); Method II ..	90
A.1	Laser End Plates .....	96
A.2	Laser Gain Tube Spacer Block .....	97
A.3	PZT Mounting Blocks .....	98
A.4	Interferometer Mount .....	99
B.1	Block Diagram of Equipment Used to Test Compensator Gc <sub>1</sub> .....	101
B.2	Measured vs Expected Frequency Response Plot for Compensator Gc <sub>1</sub> .....	102
B.3	Noise from Compensator Gc <sub>1</sub> .....	103
B.4	Spectral Content of Noise from Compensator Gc <sub>1</sub> .....	103
B.5	Schematic Block Diagram of Compensator Gc <sub>1</sub> for Variation 1 of Method I .....	104
C.1	Amplifier Assignment to Compensator Gc <sub>2</sub> .....	106

List of Figures

Figure		Page
C.2	Measured vs Expected Frequency Response Plot for Compensator $G_{c2}$ .....	107
C.3	Noise from Compensator $G_{c2}$ .....	108
C.4	Spectral Content of Noise from Compensator $G_{c2}$ .....	108
C.5	Schematic Diagram of Compensator $G_{c2}$ for Variation 2 of Method I.....	109
D.1	Amplifier Assignment to Compensator $G_{c2}$ .....	111
D.2	Measured vs Expected Frequency Response of Compensator $G_{c3a}$ .....	112
D.3	Measured vs Expected Frequency Response of the Upper Portion of $G_{c3}$ As Seen In Figure D.1 .....	113
D.4	Noise From Compensator $G_{c3a}$ .....	114
D.5	Spectral Content of the Noise from Compensator $G_{c3a}$ .....	114
D.6	Noise from Compensator $G_{c3b}$ .....	115
D.7	Spectral Content of the Noise from Compensator $G_{c3b}$ .....	115
D.8	Schematic Diagram of Compensator $G_{c3}$ for Method II .....	116

List of Tables

Table		Page
2.1	Control Loop Symbol Definitions for Figures 2.1 and 2.2 .....	13
4.1	Temperature Affects on Laser Components .....	29
7.1	Noise Reduction for Each Control Method (0 - 250 Hz Range) .....	84

### List of Symbols

<u>Symbol</u>	<u>Definition</u>
$\text{\AA}$	Angstrom, equal to $10^{-10}$ meters
$\lambda$	Wavelength of helium-neon laser. Equal to 6328 $\text{\AA}$
$\mu$	Micro, equal to $10^{-6}$
(s)	Indicates Laplace domain
$\nu$	Laser resonant frequency
$\nu_R$	Noise corrupted reference frequency
$\nu_C$	Correction frequency
$\Delta\nu$	Axial mode spacing
$\Delta\nu_T$	Change in laser frequency per change in $^{\circ}\text{F}$
$\Delta\nu_{\text{PZT}}$	Change in laser frequency due to a change in PZT length
$\Delta\nu_I$	Interferometer sensitivity in MHz/volt
$\Delta\nu_A$	Calculated value of the laser axial mode spacing
$\Delta\nu_M$	Measured value of the laser axial mode spacing
$\Delta L_T$	Change in laser cavity length per $^{\circ}\text{F}$
$\Delta L_{\text{SB}}$	Change in length of the laser spacer bar per $^{\circ}\text{F}$
$\Delta L_{\text{EP}}$	Change in length of the laser end plates per $^{\circ}\text{F}$
$\Delta L_{\text{PZTM}}$	Change in length of the PZT mounts per $^{\circ}\text{F}$
$\Delta L_{\text{PZT}}$	Change in length of the PZT per $^{\circ}\text{F}$
$\Delta L_{\text{FW}}$	Change in length of the fiberglass washer per $^{\circ}\text{F}$
$\Delta L_{\text{SW}}$	Change in length of the steel washer per $^{\circ}\text{F}$
$\Delta L_M$	Change in length of a laser mirror per $^{\circ}\text{F}$

List of Symbols

<u>Symbol</u>	<u>Definition</u>
$\Delta T$	Change in temperature in $^{\circ}F$
$\Delta T_C$	Maximum temperature that can be compensated for
A	Operational Amplifier
C	Capacitor
c	Speed of light, $3 \times 10^{10}$ cm/sec
db	Decibel
D	Denominator of $M_1$
$D_2$	Desired closed loop denominator for variation 2 of method I
$D_{3a}$	Desired denominator of the closed loop transfer function using only the PZT <sub>1</sub> portion of method II
$D_3$	Desired closed loop denominator using method II
E	Error signal
$e(t)_{ss}$	Steady state error signal
FSR	Laser free spectral range
$G_{c1}$	Compensator used for variation 1 of method I
$G_{c2}$	Compensator used for variation 2 of method I
$G_{c3}$	Compensator used for method II
$G_{c3a}$	Long PZT loop portion of $G_{c3}$
$G_{c3b}$	Short PZT loop portion of $G_{c3}$
$G_{cx}$	Dummy compensator
$G_{c1N}$	Numerator of $G_{c1}$
$G_{c1D}$	Denominator of $G_{c1}$

List of Symbols

<u>Symbol</u>	<u>Definition</u>
$G_{c3bN}$	Numerator of $G_{c3b}$
$G_{c3bD}$	Denominator of $G_{c3b}$
$G_{X1}$	Open loop transfer function for the single PZT controller without a compensator
$G'_{X1}$	Open loop transfer function using $G_{c1}$ for variation 1 of method I
$G''_{X1}$	Open loop transfer function using $G_{c2}$ for variation 2 of method I
$G_{X2}$	Open loop transfer function using the dual PZT controller $G_{c3}$ for method II
$G_{LIA}$	LIA transfer function
$G_{HVA/PZT}$	Combined transfer function of HVA and PZT
$\xi$	Resonator parameter
HVA	High voltage amplifier
Hz	Hertz
K	Killo, $10^3$
$K_{LIA}$	Unique LIA constant
$K'_{LIA}$	General LIA constant
$K_{X1}$	Numerator constant for $G_{X1}$
$K_{c1}$	Numerator constant for $G_{c1}$
$K_{m2}$	Numerator constant for $M_2$
$K_{m3a}$	Numerator constant for $M_{3a}$
$K_{m3b}$	Numerator constant for $M_{3b}$
$K_{HVA}$	HVA gain setting

List of Symbols

<u>Symbol</u>	<u>Definition</u>
$K'$	Variable gain of $G_{c1}$
$K''$	Variable gain of $G_{c2}$
$K'''_a$	Variable gain of $G_{c3a}$
$K'''_b$	Variable gain of $G_{c3b}$
L	Optical distance between laser mirrors
LIA	Lock-In-Amplifier
LIAS	LIA sensitivity setting
$m_{1,2}$	Laser mirrors
M	Meg, $10^6$
m	Milli, $10^{-3}$
$M_2$	Control ratio for method I, variation 2
$M_{3a}$	Control ratio for method II using only $G_{c3a}$
$M_3$	Control ratio for method II using $G_{c3}$
$N_2$	Desired closed loop numerator for variation 2 of method I
$N_3$	Desired closed loop numerator of method II
$N_{3a}$	Desired closed loop numerator using only the PZT <sub>1</sub> portion of method II
PZT	Piezoelectric transducer
PSD	Phase sensitive detector
q	Laser frequency integer mode number
$r_{1,2}$	Laser mirror radius of curvature

List of Symbols

<u>Symbol</u>	<u>Definition</u>
R	Resistor
sec	Seconds
v	Volts
Vd	Detector output voltage
$\infty$	Infinity

## Abstract

The purpose of this research is to compare two types of control methods that can be used to frequency stabilize a laser. The first method uses a single piezoelectric transducer (PZT) to control the cavity length of a helium-neon laser. The second method employs dual PZT controllers of different lengths so that a fast response time can be achieved with the benefit of a large dynamic range. Two variations of the first method are compared to the second method. The first variation uses an integrator with gain as a compensator in an electronic feedback control loop and is designed using steady state analysis. The second variation uses a more sophisticated compensator that is designed using frequency analysis. Frequency analysis is also used in the compensator design for the second method. Each compensator is tested in a laser control loop and the results of each method are compared.

## I Introduction

Over the last two decades, laser application has extended into the field of inertial navigation. Advancement in laser gyro technology now puts laser gyros on a competitive level with their counterpart, the mechanical gyro. Although the laser gyro does not have errors associated with moving parts, other error sources exist that effect its accuracy. A recent study by Olkowski and Holland concerning errors in a passive ring laser gyroscope, indicates a need for a frequency stabilized laser in order to overcome temperature and mechanically induced changes in the laser cavity (Ref 1:42). The following section explains how a laser resonant frequency may vary and introduces a method that can be used to stabilize the laser.

### Background

The frequency spectrum associated with a true sinusoid is a narrow line while deviations from a true sinusoid cause a broadening of that line. The helium-neon lasers used in most laser gyros display a spectrum line-shape that is inhomogeneously broadened. This means that the collection of atoms in the laser medium can exhibit several resonant frequencies for the same laser transition. The laser output intensity versus frequency plot has a gaussian like shape, so variations in frequency also cause

variations in intensity.

The actual output frequency of a laser is determined by the optical distance between the laser mirrors which is known as the cavity length. O'Shea, Callen, and Rhodes show that the length of the laser cavity is equal to an integral number of laser half wavelengths (Ref 4:91). Written in terms of frequency,

$$\nu = q \left( \frac{c}{2L} \right) \quad (1.1)$$

where  $\nu$  is the resonant frequency,  $q$  is an integer,  $c$  is the speed of light, and  $L$  is the optical cavity length. Since  $q$  can be any integer, there are many frequencies or axial modes that a laser may resonate at providing that  $\nu$  is within the gaussian shaped intensity vs frequency plot. The axial mode frequency separation,  $\Delta\nu$ , is given by

$$\Delta\nu = \frac{c}{2L} \quad (1.2)$$

Figure 1.1 shows the relationship between the laser transition intensity, the axial mode spacing, and the laser output.

From the discussion and equations just presented, it is evident that any deviation in the cavity length will cause a deviation in the output frequency and intensity. In order then to control the frequency, the cavity length

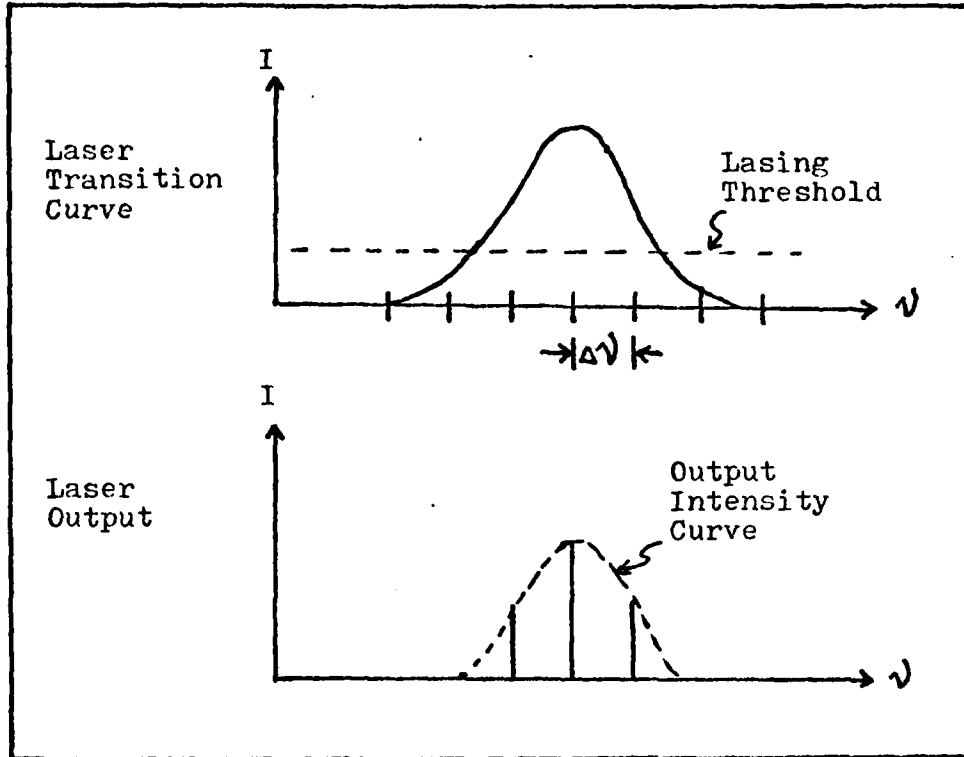

Figure 1.1 Relationship Between a Laser Transition Curve, Axial Mode Spacing, and Laser Output Intensity

must be controlled. A common approach used, and followed in this research, is to sample the laser output and compare it to a reference frequency. Deviations from the reference frequency are converted into an electrical signal. The signal is then routed through an electronic control loop to a piezoelectric transducer (PZT) that adjusts the length of the cavity to cancel the disturbance noise. The limitation on the feedback system is primarily due to the mechanical resonances of the PZT (Ref 3:346). For this reason, a method of control using two PZTs of different lengths looks very attractive. A long PZT is

needed to accommodate a large dynamic range to control disturbances such as temperature drifts. A short PZT with a fast response time is needed to control higher frequency noises.

#### Problem Statement

The purpose of this research is to ascertain the effectiveness of two control methods that can be employed to frequency stabilize a laser. The first method is a standard approach and uses a single PZT to control the length of a laser cavity. The control range of this method is limited by the length of the PZT. A long PZT is desired to provide a large control range, however, the added mass and length increases the response time. To overcome this limitation the second method uses dual PZT controllers. A long PZT is used to provide the desired control range and a short PZT is used to provide a fast response time. To ascertain the effectiveness of each control method, the magnitude and phase of the closed loop error signal must be recorded and analyzed.

#### Method of Approach

The method of approach starts with the selection of a basic control loop scheme. Laser frequency stabilization has been studied since the early sixties and, over the last two decades, many favorable schemes have been presented.

The basic scheme used in this research is similar to the one presented by P.W. Smith (Ref 3:343). An interferometer cavity is used as a frequency reference to which the laser output is compared. Frequency deviations are converted into an electrical signal and routed through an electronic feedback loop that controls the movement of a PZT to which one of the laser mirrors is attached. In this manner, noise disturbances causing frequency instability are sensed and countered by moving the PZT, thereby correcting the cavity length.

The next step in the approach was to design and build a laser. This was followed by a noise source study that included literature research and equipment experimentation. The laser control system was then modeled and transfer functions for each component were determined. Variations of method I included the design of a first compensator from steady-state analysis and the design of a second compensator using frequency analysis. The compensator for method II was also designed using frequency analysis. Finally, each compensator was used in the control loop and a spectrum analysis was made of the error signal. Results of each test were recorded and a comparison was made of the two control methods.

#### Order of Presentation

A description and results of the research are

presented in the following manner. First, the frequency stabilization theory is presented in Chapter II and is followed by a discussion of the laser design in Chapter III. Next, noise sources are analyzed in Chapter IV and system model parameters are determined in Chapter V. The compensators are designed in Chapter VI, and performance results and comparisons are presented in Chapter VII. Finally, conclusions and recommendations are made in Chapter VIII. In order to fully comprehend this material the reader should have a basic knowledge of the techniques used to frequency stabilize a laser.

## II Frequency Stabilization

### General Description

As pointed out in Chapter I, the output of a laser can contain many discrete frequencies separated by  $\Delta\nu$ . It was also pointed out that changes in the cavity length cause variations in the frequency output of the laser. Environmental noises such as temperature drift, acoustic noise, and table vibrations all contribute to fluctuations in the cavity length. Properties of the laser itself also contribute to frequency fluctuations, termed as output noise. The following two control methods are designed to reduce the effects of these noise disturbances.

Method I is a standard method and consists of a single PZT that controls the cavity length. As mentioned in the introduction, the limitation on the feedback system is primarily due to the mechanical resonances of the PZT. A long PZT is desired for its large dynamic range; however, the added length and mass lower the mechanical resonance and increases the response time. For this reason a second method of control is studied.

Method II consists of dual PZTs of different lengths to control the laser cavity length. A long PZT is used for its dynamic range and a short one is used to provide a fast response time.

The theory for each method is described in the

following sections, but first, the Fabry-Perot interferometer theory will be explained as it establishes the frequency reference for the control loop.

### Fabry-Perot Interferometer

The Fabry-Perot interferometer shown in Figures 2.1 and 2.3 acts as a frequency reference to which the laser output is compared. As described by O'Shea, Callen, and Rhodes, a Fabry-Perot interferometer is an optical resonant cavity that consists of a pair of highly reflective mirrors parallel to each other, and whose separation can be varied (Ref 4:33). They further show that for most wavelengths only a small percentage of the light entering the cavity is transmitted. For certain wavelengths, however, nearly 100% of the light is transmitted. This transmission occurs when the optical distance between the mirrors equals an integral number of half-wavelengths of the incident light. The condition for resonance then is

$$\nu_x = m \left( \frac{c}{2d} \right) \quad (2.1)$$

where  $\nu_x$  is a resonant frequency of the interferometer,  $m$  is an integer,  $c$  is the speed of light, and  $d$  is the optical distance between the mirrors. Notice that Eq (2.1) is similar to Eq (1.1) as both the interferometer cavity and the laser cavity work on the same principle.

For a confocal cavity (radius of curvature of the mirrors equals the optical cavity length) with the reflectance of both mirrors close to unity, the transmittance,  $I_T$ , of an interferometer near a resonant frequency is (Ref 8:5)

$$I_T = \frac{1}{(1 + A/T)^2 \left[ 1 + \left( \frac{4\pi d}{\lambda(1-R)} \right)^2 (\nu_N - \nu_I)^2 \right]} \quad (2.2)$$

where  $A$  is the dissipative mirror loss,  $T$  is the mirror transmittance,  $R$  is the mirror reflectivity,  $d$  is the optical distance between the cavity mirrors,  $\nu_I$  is the cavity resonant frequency, and  $\nu_N$  is a frequency close to resonance. For the Jodon SA-1500 interferometer used in this research  $A < 0.2\%$ ,  $T \approx 0.8\%$ ,  $R \approx 99\%$ ,  $d = 5\text{cm}$ .

At resonance, the last term in the denominator of Eq (2.2) is zero and the transmittance becomes

$$I_T = \frac{1}{(1 + A/T)^2} \quad (2.3)$$

Using the values shown for the Jodon SA-1500 interferometer,

$$I_T = 64\% \quad (2.4)$$

It is easy to see from the denominator of Eq (2.2) that a small relative change in the frequency of the

incident light will create a large change in  $I_T$ . As an example, if  $(\nu_N - \nu_I) \approx 2$  MHz, which is small considering that  $\nu$  for a helium-neon laser is  $4.74 \times 10^{14}$  Hz, then

$$I_T = \frac{1}{\left(1 + \frac{0.002}{0.008}\right)^2 \left[1 + \left(\frac{4\pi \cdot 5 \text{ cm}}{3 \times 10^{10} (1-0.99)}\right)^2 (2 \times 10^6 \text{ Hz})^2\right]}$$

$$= 54.4\% \quad (2.5)$$

This is a 9.6% decrease in  $I_T$ . This rapid drop in output intensity for a slightly off-resonance condition makes the Fabry-Perot interferometer an excellent device to use as a frequency standard in a control loop.

From Eq (2.1), if the cavity length is swept over a range of several wavelengths, the interferometer acts as a spectrum analyzer and can be used to show the spectral content of a laser as shown in Figure 2.0. The sharp peaks in Figure 2.0 represent the output frequencies of the laser that was built for this research.

In order to sweep the cavity length over several wavelengths, a slow varying ramp voltage is applied to a PZT mounted inside the interferometer housing. The PZT has one of the interferometer mirrors mounted to it so that a change in PZT length, caused by an external voltage, changes the optical cavity length and thus changes the condition for resonance.

The range of frequencies that can be swept through

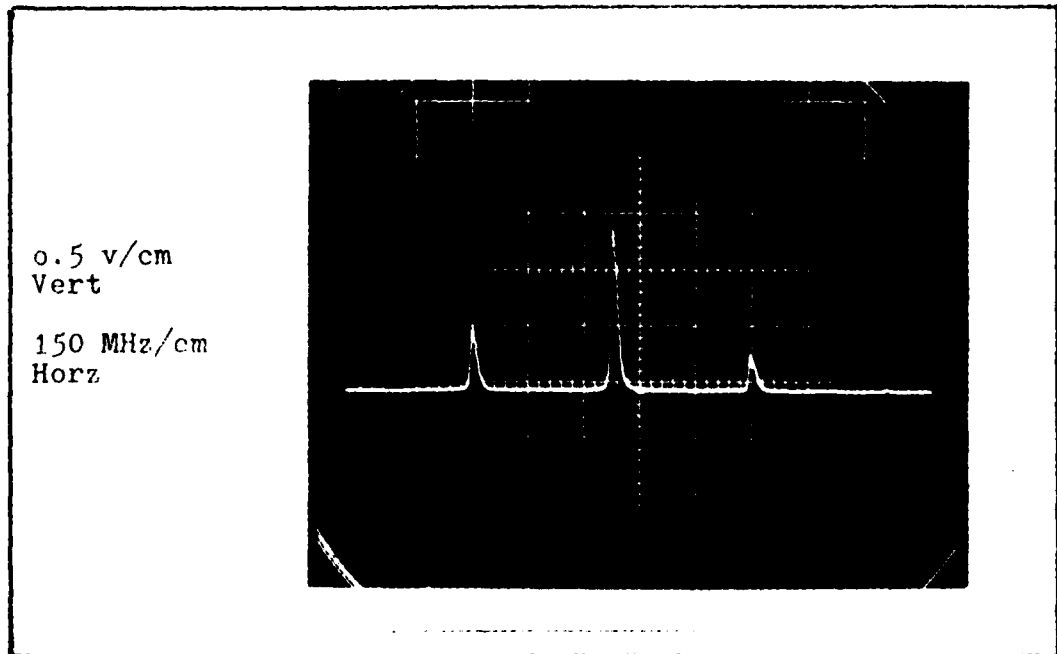

Figure 2.0 Laser Output Scanned With the Reference Interferometer

without repetition is known as the free spectral range (FSR), where

$$FSR = \frac{c}{2d} \quad (2.6)$$

The FSR for the laser used in this research is 1500 MHz. A Fabry-Perot interferometer is used as a frequency reference in both control methods I and II as seen in the following sections.

#### Control Method I

A control loop block diagram for the system used in method I is shown in Figure 2.1. The control loop model

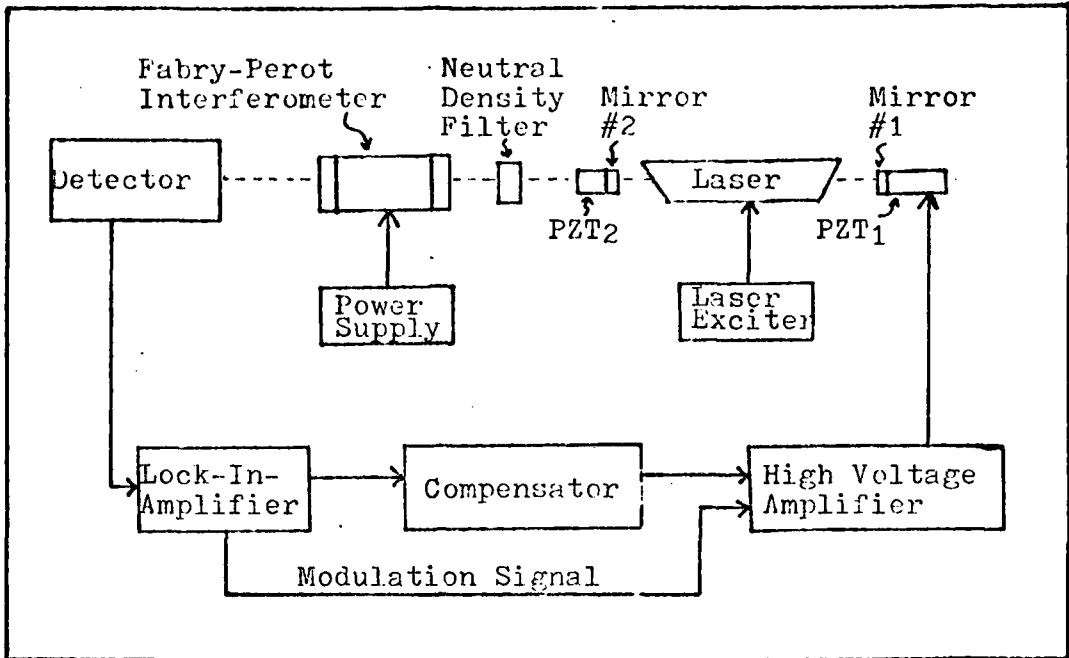

Figure 2.1 Control Loop Block Diagram for Control Method I

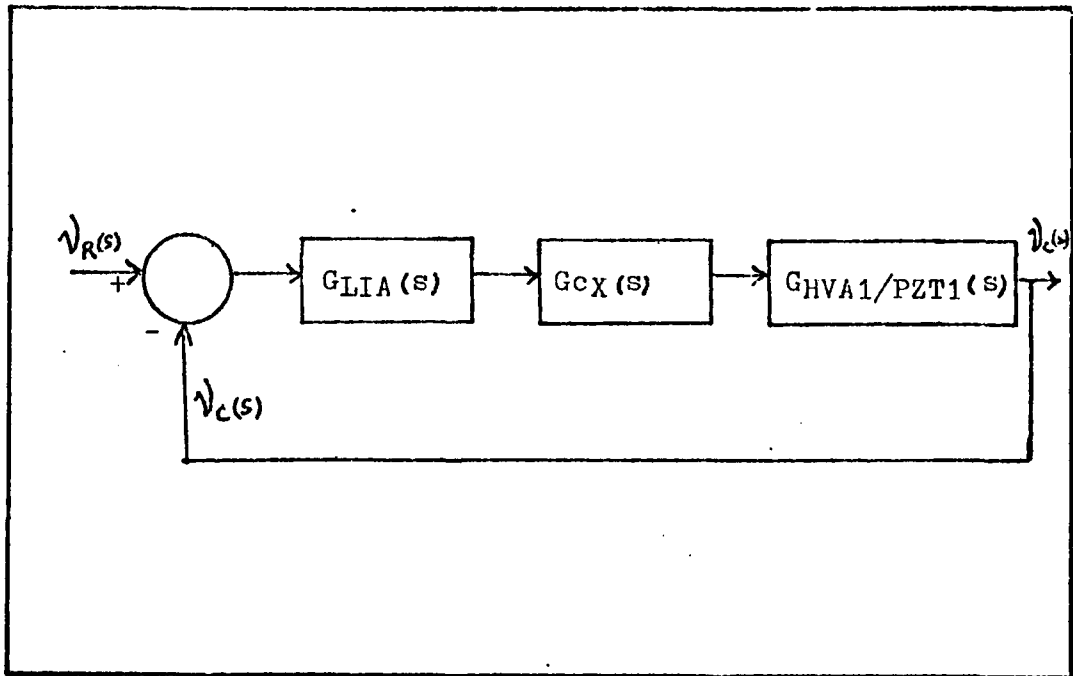

Figure 2.2 Control Loop Model for Control Method I

Table 2.1

Control Loop Symbol Definitions for Figures 2.2 and 2.4

<u>Symbol</u>	<u>Definition</u>
$v_R$	Noise corrupted reference signal
$v_C$	Control loop correction signal
GLIA	Lock-In-Amplifier transfer function
GHVA1/PZT1	High Voltage Amplifier #1/Piezoelectric Transducer #1 transfer function
GHVA2/PZT2	High Voltage Amplifier #2/Piezoelectric Transducer #2 transfer function
GcX	Compensators

for the system is shown in Figure 2.2 with symbols defined in Table 1.1.

Looking at Figure 2.1, light from the laser is passed through a neutral density filter and enters the Fabry-Perot interferometer. The neutral density filter reduces the intensity of the laser light in order to keep the detector in its linear region. The interferometer PZT is used to match the interferometer resonant cavity to a laser mode that has been positioned at the top of the laser output intensity curve with PZT<sub>1</sub>. A frequency deviation in the laser output causes an off-resonant condition in the interferometer as explained earlier. The detector senses a sharp decrease in the intensity from the interferometer which results in a decrease in

voltage to the lock-in-amplifier (LIA). The LIA is the heart of the control loop and produces an error signal that locks the laser to the interferometer resonant frequency. A modulation technique is used within the LIA which locks the laser frequency to the interferometer resonance. This technique will be discussed in full detail in the following section. With reference to Figure 2.1, the error signal from the LIA is routed through a compensator that is designed in Chapter VI. The signal then goes to high voltage operational amplifier 1 (HVA<sub>1</sub>). Note that the modulation frequency used in the LIA is also routed directly to HVA<sub>1</sub>. The HVA sends a final correction signal to PZT<sub>1</sub> that has laser mirror m<sub>1</sub> mounted to it. Movement of the PZT by the loop counters the noise disturbance that caused the original frequency fluctuation in the laser output. In this manner, the laser is locked to the interferometer resonant frequency and noise that is within the bandwidth of the loop is suppressed.

The operation of control method II is similar to that just presented and is discussed in the following section.

#### Control Method II

A control loop block diagram for control method II is shown in Figure 2.3. The model for the system is shown in Figure 2.4 with symbol definitions as shown in Table 2.1.

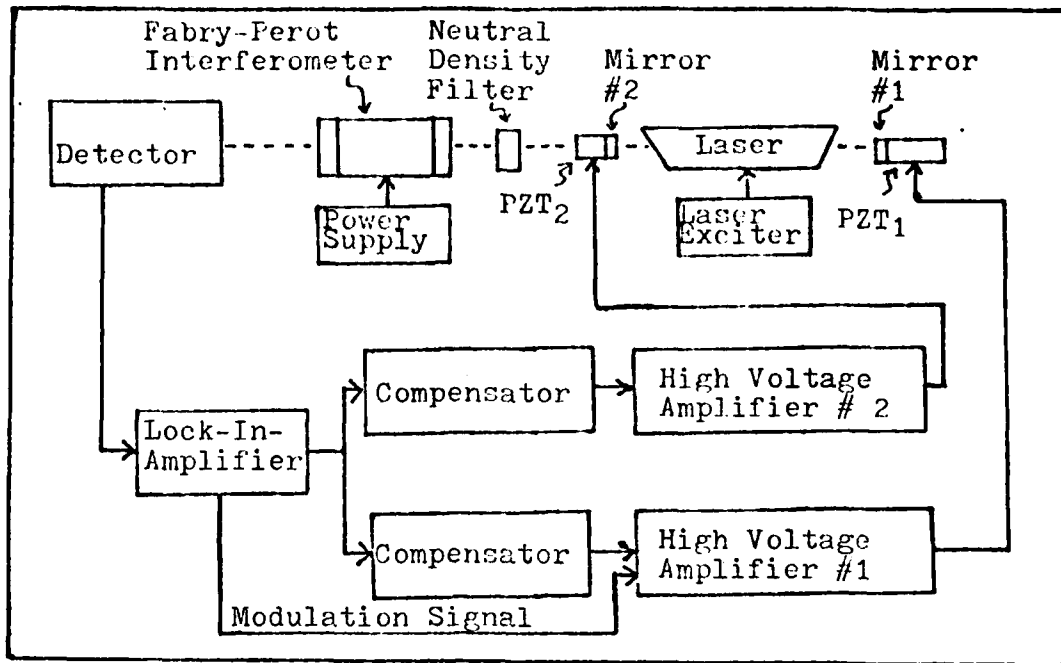

Figure 2.3 Control Loop Block Diagram for Control Method II

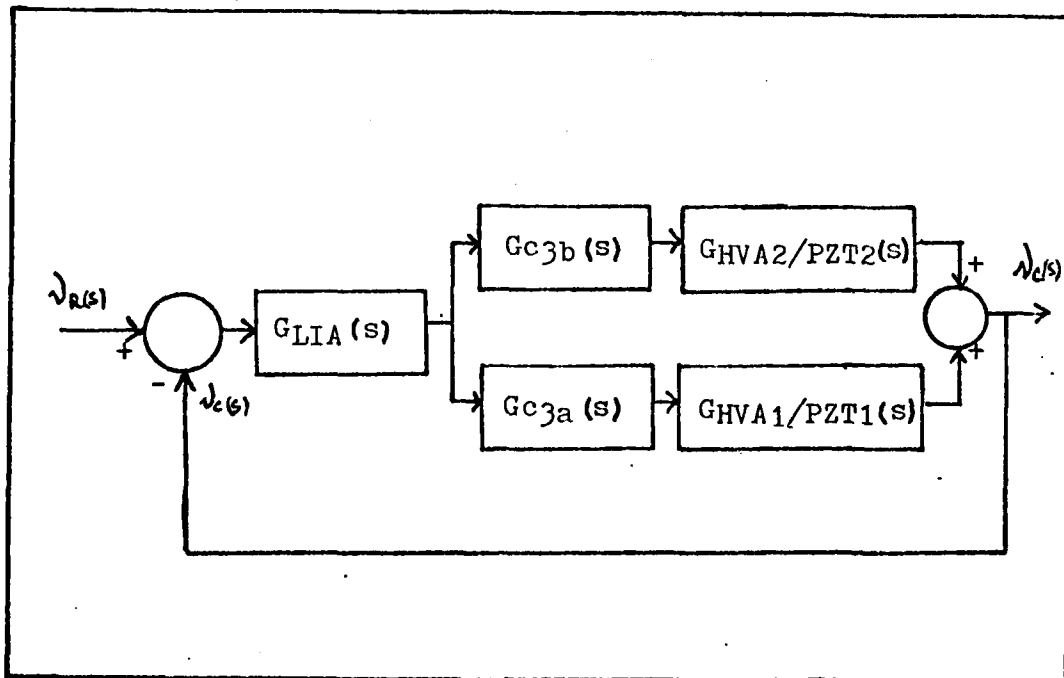

Figure 2.4 Control Loop Model for Control Method II

The theory used in control method II is the same as that for method I; however, the signal from the LIA is now split and goes to two different compensation networks. The design of these networks are quite different from each other and are fully described in Chapter VI. Correction signals leave each of the compensators and are amplified by  $HVA_1$  and  $HVA_2$  that control respective PZTs. Note that the modulation signal still goes to  $HVA_1$  as in the previous section. The modulation technique is the same for both control methods and is described in the next section.

#### Modulation Technique

As stated earlier, the LIA is used to lock the laser frequency to the interferometer resonance. It accomplishes this by comparing the phase of a modulation signal to the phase of the returned signal from the detector and creates an error voltage proportional to the phase difference. A 41 KHz modulation signal is selected, as it is a resonant frequency of  $PZT_1$  and is well beyond the bandwidth of the control loop.

Figures 2.5 through 2.8 are used to illustrate the reaction of the LIA to a frequency shift in the laser. When the laser cavity length is such that the laser frequency corresponds to point A in Figure 2.5, the output of the interferometer is at a maximum. As the PZT is

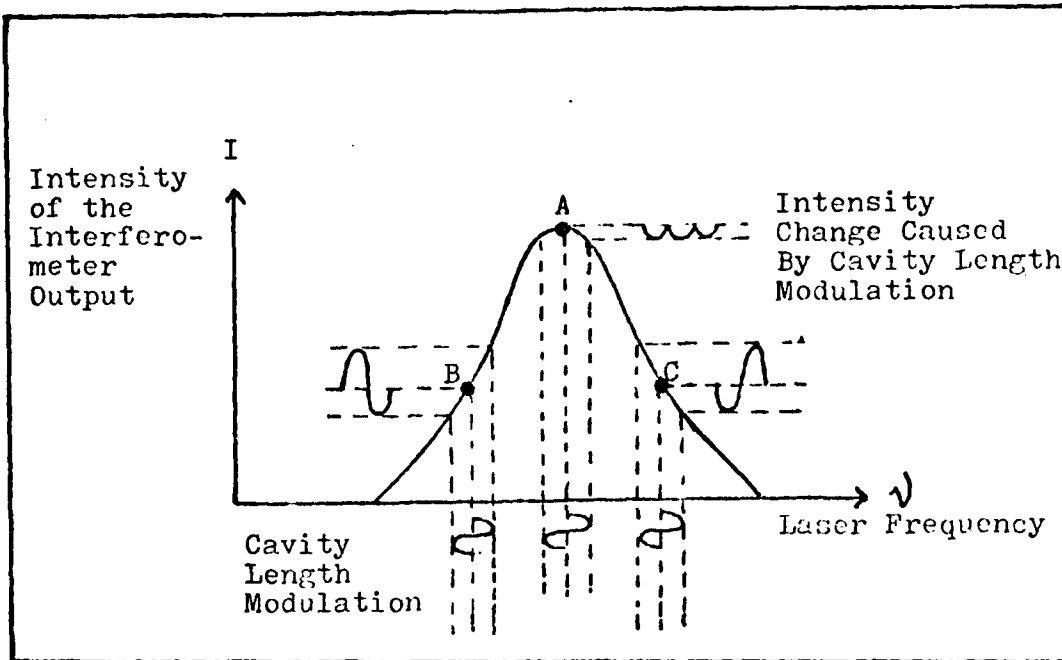

Figure 2.5 Interferometer Intensity vs Laser Frequency

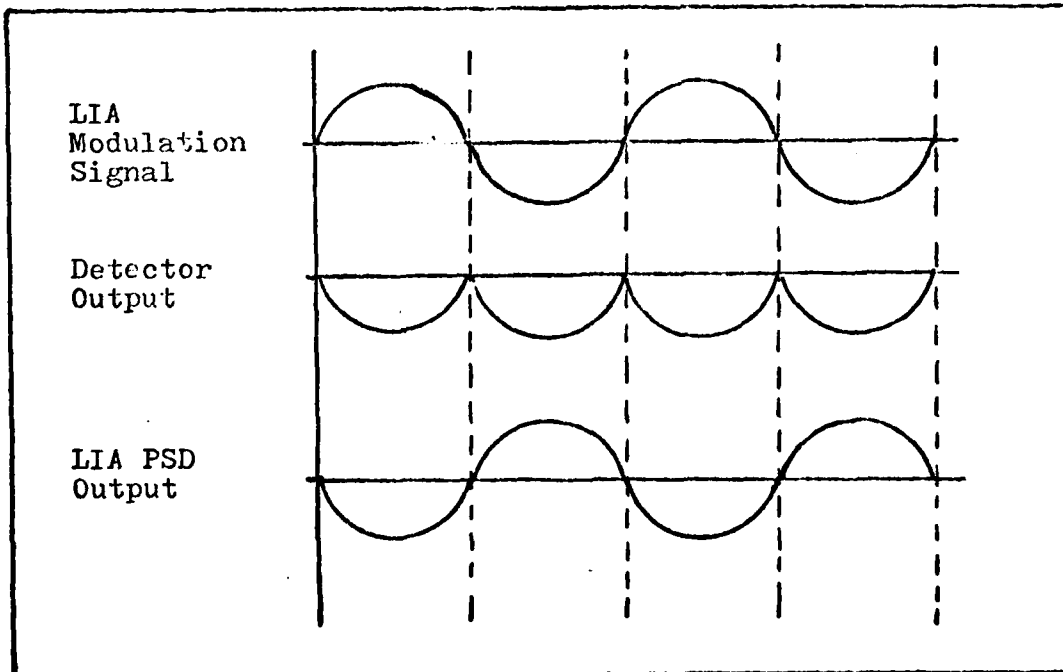

Figure 2.6 LIA Phase Comparison A

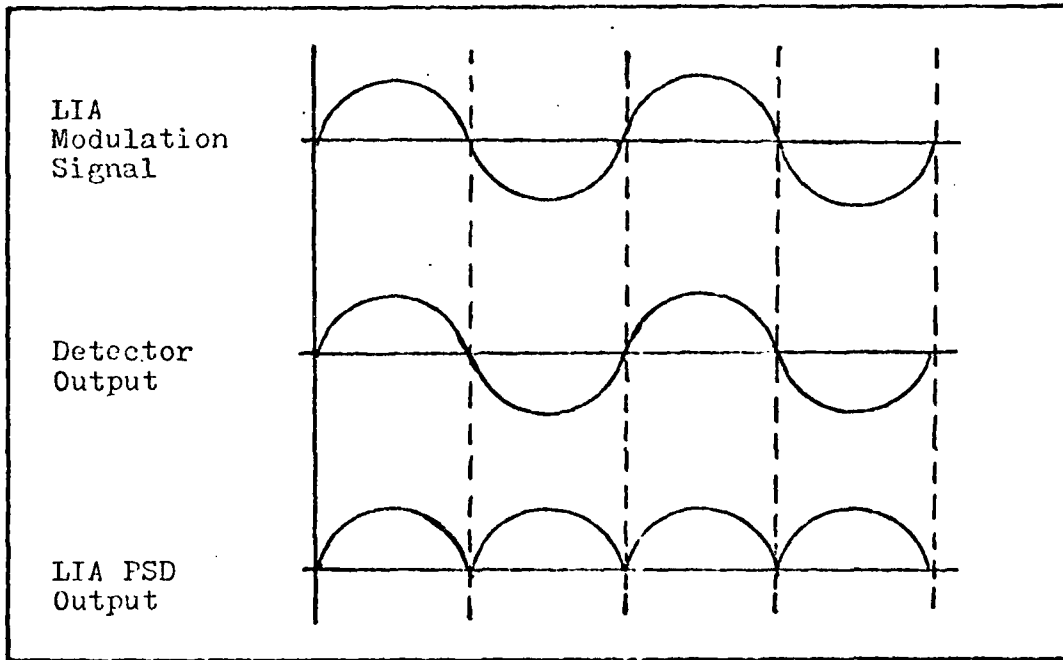

Figure 2.7 LIA Phase Comparison B

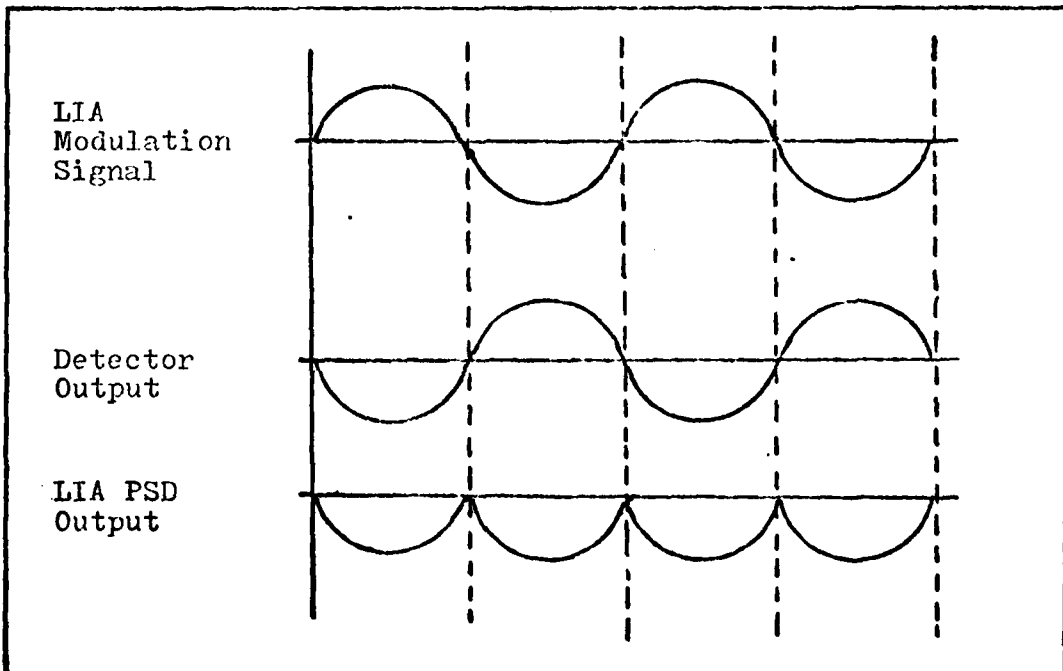

Figure 2.8 LIA Phase Comparison C

dithered by the modulation signal, it causes the laser to oscillate about point A which produces the detector output as shown in Figure 2.6. The modulation signal and the output of the detector are mixed in the LIA. The mixer, called a phase sensitive detector (PSD), produces the signal shown in Figure 2.6. The PSD signal is sent through a low pass filter inside the LIA which results in a zero DC level error signal. The laser cavity length thus remains unchanged.

When the laser cavity length produces a frequency corresponding to point B in Figure 2.5, the output of the interferometer is less than maximum. The modulation signal then causes the detector output to vary as shown in Figure 2.7. The LIA PSD produces a net positive signal as shown. This results in a positive DC level error signal. The error signal is routed to the PZT and causes it to lengthen thus increasing the laser frequency until it corresponds to point B in Figure 2.5.

When the laser cavity length produces a frequency corresponding to point C, the action is the same as that shown for point B, with signals as shown in Figure 2.8. For this case, the LIA produces a negative DC level error signal which results in an increase in cavity length and a lowering of the laser frequency to that corresponding to point B in Figure 2.5.

In the manner just described the laser frequency is

locked to the Fary-Perot interferometer resonant frequency. As noise causes the laser frequency to shift, the LIA and feedback loop always drives the frequency back to point B in Figure 2.5.

As stated in the introduction the limitation on the feedback system is primarily due to the PZT. The type of control compensation can also affect the control loop and is discussed in the following section.

### Compensators

By adding compensators to the feedback loop, parameters of the loop can be altered. Three different types of compensators are designed, built, and tested with comparisons of the results made in Chapter VII.

The first compensator is used in the first variation of method I. It is designed using steady state analysis and consists of an integrator with gain. The presence of the integrator in the loop creates a type I system and, as pointed out by A.D. White, the system steady state error is expected to be zero for a step input and finite for a ramp input (Ref 2:350). White also points out that this may not be the most desirable compensator as it does nothing for the bandwidth of the loop.

The second compensator is used in the second variation of control method I. It is designed using the Guilleman-Truxal design procedure presented by D'Azzo and

Houpis (Ref 7:408). The compensator is basically an extension of the first design with additional circuitry to provide a closed loop bandwidth of 2 KHz. The second compensator is expected to increase the bandwidth of the control loop as compared to the first.

The third compensator is quite different from the first two as two PZTs are now used to control the cavity length. Different size PZTs are used in the laser design to accommodate both quick response and a large dynamic range. The compensator for the long PZT loop is designed first for a closed loop bandwidth of 100 Hz and ignores the short PZT loop. The compensator for the short PZT loop is then designed for a total system closed loop bandwidth of 2 KHz.

The overall step-by-step design of the compensators is presented in Chapter VI, but before that is done, the laser designed and built for this research will be described in the next chapter.

### III Laser Design

#### General Description

A diagram of the laser is shown in Figure 3.1. The laser cavity is made up of two carbon steel end plates and utilizes four super-invar rods as spacer bars. Stainless steel mounting blocks are held to the end plates with four corner screws and alignment is accomplished with shims. PZT<sub>1</sub> is 1.5 inches long, and PZT<sub>2</sub> is 0.5 inches long. They are secured in their respective mounting blocks using set screws and epoxy glue. The laser mirrors are each glued to steel washers that are in turn glued to fiberglass insulators. Each of these combinations are glued to a PZT with the output mirror attached to PZT<sub>2</sub>. The laser gain tube is held in place by two carbon steel support blocks that are suspended from the four spacer bars. The total cavity length, L (optical distance between mirrors), is equal to 39 cm. Scale drawings of the laser hardware are included in Appendix A. Figure 3.2 is a picture of the assembled laser and includes the reference interferometer.

A discussion concerning each critical component in the laser design is presented in the following sections.

#### Laser Gain Tube

A Spectra-Physics model 120 helium-neon gain tube is

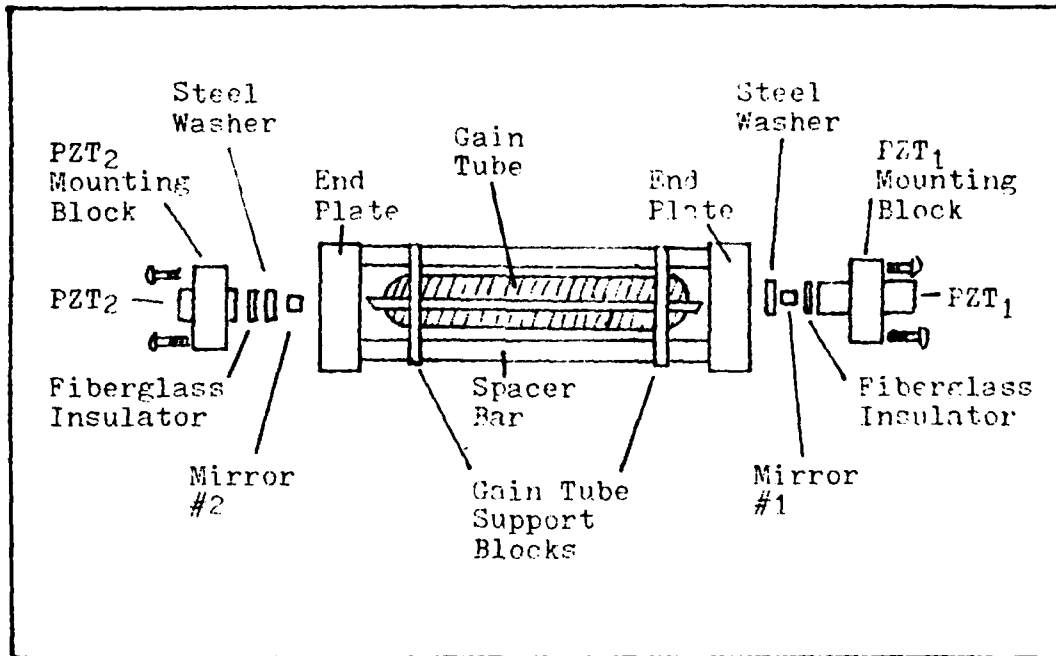

Figure 3.1 Laser Design

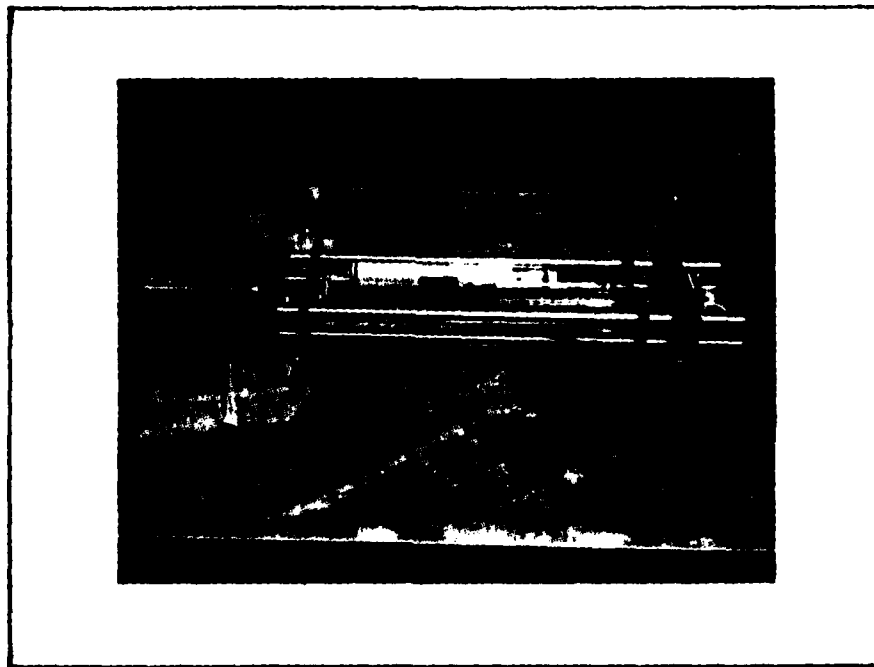

Figure 3.2 Assembled Laser With Interferometer

used as the heart of the laser and is pumped by a Spectra-Physics model 249 power supply. The gain tube draws approximately 6.0 ma and is designed for a 5 mw output.

### Laser Mirrors

The laser mirrors were selected from parts on-hand in accordance with the following stability criteria. For stability,

$$0 < g_1 g_2 < 1 \quad (3.1)$$

where  $g_1$  and  $g_2$  are dimensionless quantities and are the g-parameters of the resonator. The resonator g-parameters are

$$g_1 = 1 - \frac{L}{r_1} \text{ and } g_2 = 1 - \frac{L}{r_2} \quad (3.2)$$

where  $r_1$  and  $r_2$  represent the radii of curvature of mirrors  $m_1$  and  $m_2$  and equal  $\infty$  and 85 cm respectively. Solving Eq (3.2),  $g_1=1$ , and  $g_2=0.541$ . Eq (3.1) then becomes

$$0 < 0.541 < 1 \quad (3.3)$$

and the stability criteria is met.

The transmittance of  $m_1$  and  $m_2$  are 0.01% and 2.0% respectively where  $m_2$  is the output mirror.

### Piezoelectric Transducers (PZTs)

The PZTs selected to adjust the cavity length are tubular transducers with wall thicknesses of  $1/4$  inches. One PZT is  $1/2$  inch long and the other is  $1-1/2$  inches long. The PZTs are center mounted, as shown in Figure 3.1, to eliminate reaction movement by the mount. Although data specifications such as bandwidth and sensitivity for the PZTs are given by the manufacturer, mounting methods make it necessary to experimentally obtain all required data. This is accomplished in Chapter V.

### End Plate Spacer Bars

Super-invar is used as the spacer bar material because of its very low temperature expansion coefficient. The importance of this can be seen by looking at Eq 4.1, Table 4.1, the Eqs that follow Table 4.1, and the following example.

If mild steel was used instead of super-invar,  $\Delta L_{SB}$  from Table II would be  $94.75 \times 10^{-6}$  inches instead of  $3.00 \times 10^{-6}$  inches. This would result in  $\Delta L_T$  equal to  $257.1 \times 10^{-6}$  cm/ $^{\circ}$ F instead of the value  $24.06 \times 10^{-6}$  cm/ $^{\circ}$ F found in Eq (4.2). The output frequency drift would then be  $-3125$  MHz/ $^{\circ}$ F rather than the value  $-292.5$  MHz/ $^{\circ}$ F shown in Eq (4.6). Using Eq (4.8), the range of temperature controllable by the laser would only be  $0.03^{\circ}$ F instead of  $0.32^{\circ}$ F as shown. With a controllable range this small,

it would be very difficult to keep the laser frequency stabilized.

#### Axial Mode Spacing

The calculated axial mode spacing  $\Delta\nu_A$  is determined from Eq (1.2) and the measured value of L which is 39 cm. Then

$$\begin{aligned}\Delta\nu_A &= \frac{3 \times 10^{10} \text{ cm/sec}}{(2)(39 \text{ cm})} \\ &= 385 \text{ cm} \end{aligned} \tag{3.5}$$

It must be noted here that the determination of L was crude and will only be used to verify the much more accurate measured value of the axial mode spacing,  $\Delta\nu_M$ .

Figure 3.3 is a picture of the laser output when scanned with the reference interferometer. The FSR of 1500 MHz is spread over 10 cm so that each cm equals 150 MHz. Since axial modes are shown to be 2.5 cm apart, the mode spacing is

$$\begin{aligned}\Delta\nu_M &= \frac{(1500 \text{ MHz})(2.5 \text{ cm})}{10 \text{ cm}} \\ &= 375 \text{ MHz} \end{aligned} \tag{3.6}$$

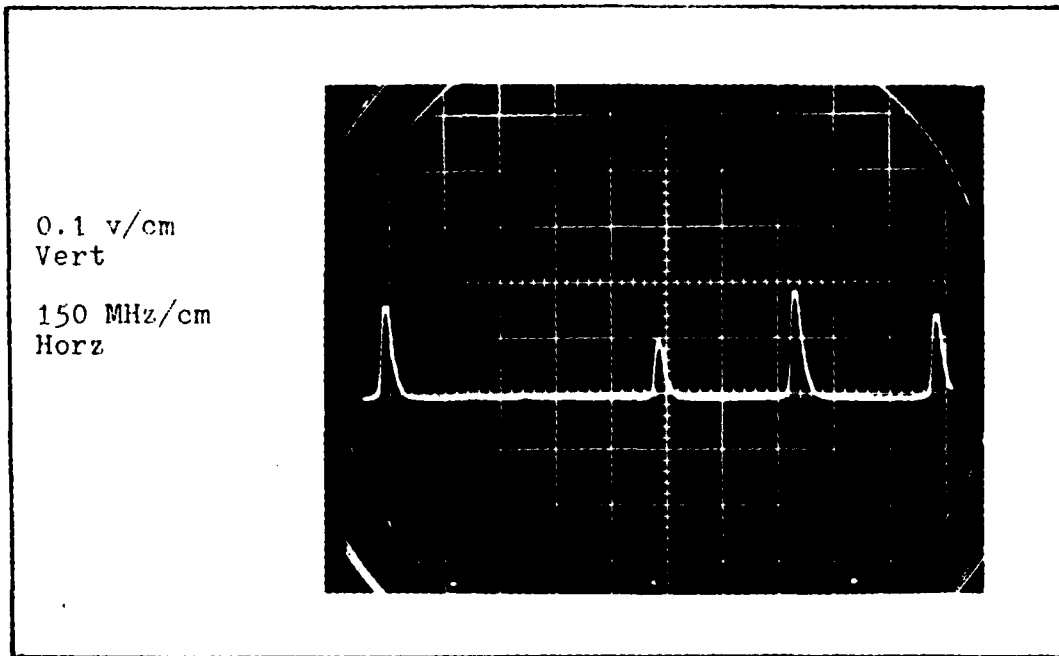

Figure 3.3 Laser Output Scanned With the Reference Interferometer for FSR Calculations.

Since it is difficult to perform this measurement due to laser drift,  $\Delta\nu_M$  was determined several times and equation 3.6 is the average of those measurements. This is within 3% of the calculated value. The result of Eq (3.6) will be used in later calculations.

Although the laser is designed with noise suppression in mind, it is still subject to many disturbances that cause output noise. Some of these sources are studied in the following chapter.

## IV Laser Noise Sources

### General Discussion

Noise sources that cause frequency fluctuations in a laser can be grouped into three categories: environmental noises, noises from the gain tube, and noises from the control loop. Environmental noises are the predominant ones and consist of temperature drifts, acoustical noise, and table vibrations. Noises from the gain tube are caused by such things as variations in the index of refraction of the active gas, variations in the gas pressure and temperature, and variations in the discharge conditions. Noise from the control loop is emitted from the electronic components and is very small.

Most of the noises can be calculated and will be analyzed in the following sections. From the results, it is expected that the spectral content of appreciable laser noise will be well below 3 KHz and will be controllable.

### Laser Noise due to Temperature Changes

Temperature drift or fluctuation is low frequency in nature and is by far the largest contributor to laser frequency noise. The biggest affect is on the cavity length, and this is the reason invar material was chosen for the spacer bars. The change in cavity length,  $\Delta L_T$ , due to temperature change,  $\Delta T$ , in degrees Fahrenheit is

Table 4.1

## Temperature Affects on the Laser Components

Component	Component Length	Temp. Coef. $10^{-6}$ in/in F	L due to T	
			$10^{-6}$ in	Symbol
Super Invar Spacer Bars	15.040	0.2	3.008	$\Delta L_{SB}$
Mild Steel End Plates	11.000	6.3	6.3	$\Delta L_{EP}$
Stainless Steel PZT Mounts	0.375	9.6	3.6	$\Delta L_{PZTM}$
PZTs	1.000	1.18	1.18	$\Delta L_{PZT}$
Fiberglass Washer	0.026	5.5	0.143	$\Delta L_{FW}$
Mild Steel Washer	0.097	6.3	0.611	$\Delta L_{SW}$
Mirror	0.250	6.0	1.5	$\Delta L_M$

calculated using Eq (4.1), as follows:

$$\Delta L_T = \Delta L_{SB} + \Delta L_{EP} + \Delta L_{PZTM} - \Delta L_{PZT} - \Delta L_{FW} - \Delta L_{SW} - \Delta L_M \quad (4.1)$$

The terms in Eq (4.1) are defined in Table 4.1.

Using the values from Table 4.1 and converting them to cm yields

$$\Delta L_T = 24.06 \times 10^{-6} \text{ cm}/^\circ\text{F} \quad (4.2)$$

The change in frequency,  $\Delta \nu_T$ , due to  $\Delta T$  can be calculated from Eq (1.1).

The effect on  $\nu$  caused by a small change in L is

$$\delta\nu = \frac{-8c}{2L^2} \delta L \quad (4.3)$$

If  $\Delta L_T$  and  $\Delta\nu_T$  are assumed to be small then they can be substituted into Eq (4.3) so that

$$\Delta\nu_T = \frac{-8c}{2L^2} \Delta L_T \quad (4.4)$$

Substituting  $q\lambda$  for  $2L$ , Eq (4.4) becomes

$$\Delta\nu_T = \frac{-c}{\lambda L} \Delta L_T \quad (4.5)$$

Then

$$\begin{aligned} \Delta\nu_T &= \frac{-(3 \times 10^8 \text{ m/sec})}{(6328 \times 10^{-10} \text{ m})(39 \text{ cm})} (24.06 \times 10^{-6} \text{ cm/}^\circ\text{F}) \\ &= -292.5 \text{ MHz/}^\circ\text{F} \end{aligned} \quad (4.6)$$

The sensitivity of PZT<sub>1</sub> from Chapter V is used to calculate the controllability of the laser due to temperature changes. From Eq (5.1), the PZT<sub>1</sub> sensitivity in terms of  $\nu$  is 0.1875 MHz/volt. With 500 volts available from the HVA, the change in laser frequency,  $\Delta\nu_{\text{PZT}_1}$ , due to a maximum change in length of PZT<sub>1</sub>, is

$$\Delta\nu_{\text{PZT}_1(\text{max})} = 93.75 \text{ MHz} \quad (4.7)$$

Using Eqs (4.6) and (4.7) to solve for the maximum temperature change that can be compensated for using PZT<sub>1</sub> yields:

$$\begin{aligned}\Delta T_c &= \frac{\Delta \nu_{PZT1}}{\Delta \nu_T} \\ &= \frac{93.75 \text{ MHz}}{292.5 \text{ MHz}/^\circ\text{F}} \\ &= 0.32^\circ\text{F} \qquad (4.8)\end{aligned}$$

It must be noted that a change in temperature also changes the cavity length of the interferometer. For this reason, the interferometer was thermally wrapped with styrofoam and tape to reduce the effect of temperature changes during an experiment.

#### Laser Noise Due to Acoustical Noise and Table Vibration

Since actual measurements of acoustical and vibrational effects were not made, an experiment by Haruhiko Nagai was used to estimate their effects and is presented here (Ref 6). The construction of Nagai's laser and the one used in this research are very similar. The major differences are that his cavity length is about one third the size of the one used here, and his mirror holders use spring loaded adjustment screws where the holders used here are hard mounted with shims.

In part of Nagai's experiment, he determines the lowest natural frequency of each mechanical element in the cavity by the use of sound pressures generated by a loud speaker. He compares the results with those obtained analytically to show that the mirror holder system's natural frequency has components of 40 Hz and 100 Hz, while the frequency of the spacer system is 3 KHz (Ref 6:863). Since the mirror holders on the laser used here are hard mounted, it is assumed that the noise content will not be any greater than found by Nagai. Also, since the spacer system used here is three times longer, the spacer system resonant frequency is expected to be smaller than 3 KHz.

Nagai shows that his laser frequency fluctuations due to acoustical noise was about 9.6 KHz and that due to vibrations was about 110 KHz (Ref 6:863). Care was taken during this research to isolate the laser work-plate by placing it on foam rubber. Also, a plastic shield was used to cover the laser in order to isolate the laser from acoustical noise. With the precautions taken, it is assumed that the affects of vibration and acoustical noise would not be very much greater than that found by Nagai.

#### Laser Noise from the Gain Tube Noises

Gain tube noises are very small compared to the others presented. Nagai points out that variations in

the refractive index of active gas is about 1 MHz/ma for a laser tube very similar to the one used in this research (Ref 6:858). Since the laser power supply has less than a 0.3 ma variation, a laser noise of less than 300 KHz is expected. Other noises previously mentioned are troublesome only when stability requirements are greater than 1 part in  $10^{10}$  (Ref 5.11).

#### Noises from the Control Loop

Noises from the control loop are very small, as seen in Figures 4.1 to 4.5 found at the end of this section, and have little affect on the laser frequency. This is due to a very high signal-to-noise ratio in the circuitry and also to the fact that almost all of the gain in the loop is put into the preamplifier of the LIA.

An example of a typical open loop signal-to-noise ratio achieved in the loop can be given by looking at the noise from the LIA shown in Figure 4.3. The maximum peak-to-peak amplitude is about 0.1 volts. The expected error signal produced from a 1 MHz shift in the laser frequency is 12 volts, as shown by Eq (5.4). This equates to a signal-to-noise ratio of about 120 to 1. With a large gain at the front end of a closed loop, noise created in the loop is effectively reduced providing it is within the bandwidth of the loop.

Figures 4.6 to 4.10, located at the end of this

section, show the frequency spectrum of the noise from each of the control loop components. Most of the noise from the components is less than 500 Hz/sec. The LIA has the largest spectral spread and decays exponentially to about 20 db between zero and two KHz as seen in Figure 4.8.

HVA<sub>2</sub> has a noise component of 1.2 MHz, as seen in Figure 4.5, which is outside the bandwidth of the control loops. This noise, however, has little affect on the laser frequency because of its small amplitude and because it is far beyond the mechanical response limit of the PZTs.

A noise source that is critical is the interferometer power supply as it causes fluctuations in the reference frequency. The noise level is shown to be about 0.006 volts as seen in Figure 4.1 and has a 60 Hz/sec spectral content. Using Eq (5.1), the reference frequency fluctuations are about 41 KHz and will occur at a 60 Hz/sec rate. This is only significant for a stability requirement greater than 1 part in  $10^{10}$ .

In summary, a control loop with a 2.0 KHz bandwidth should be able to reduce all of the critical noises shown in this section.

Identification of noise sources is a major step in the design of a good control network. Determination of control loop parameters is also a major step and is accomplished in the following chapter.

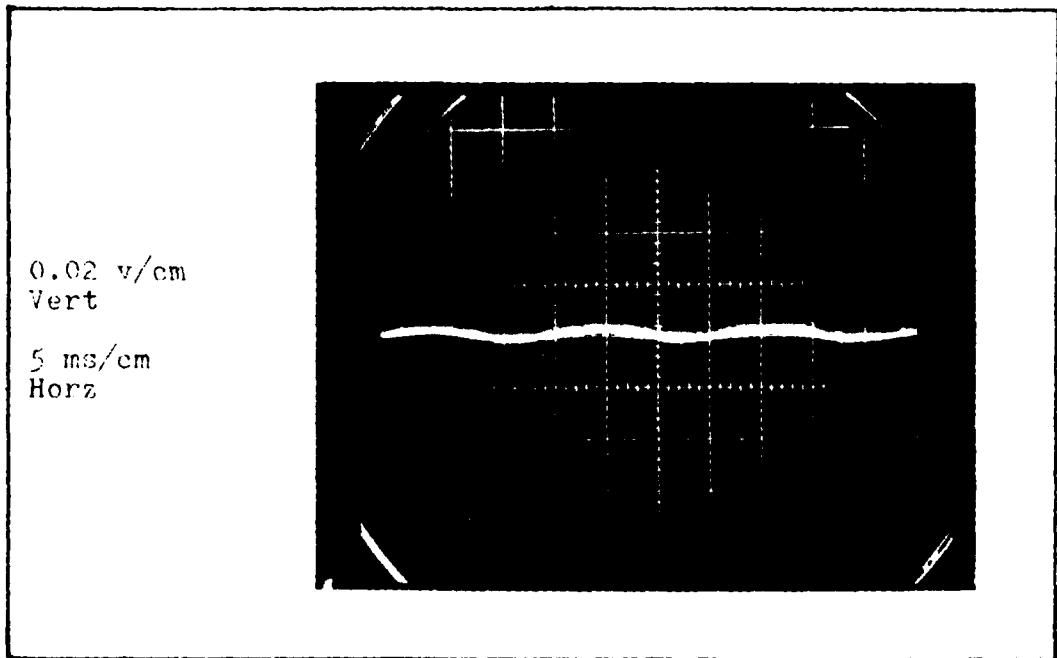

Figure 4.1 Noise from the Interferometer Power Supply

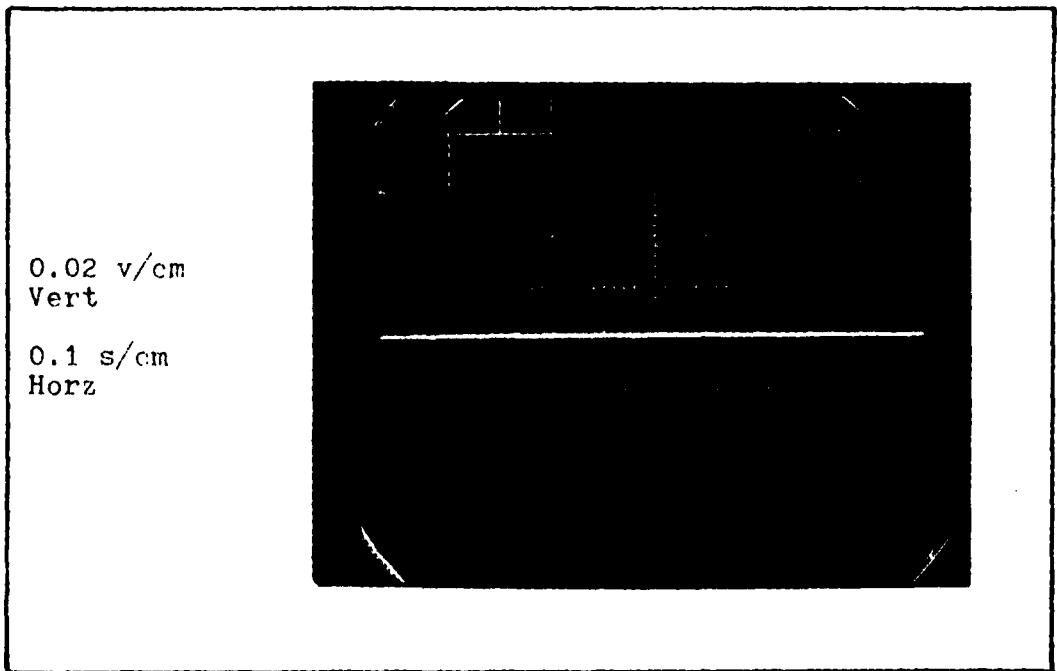

Figure 4.2 Noise from the Detector With the Laser Blocked

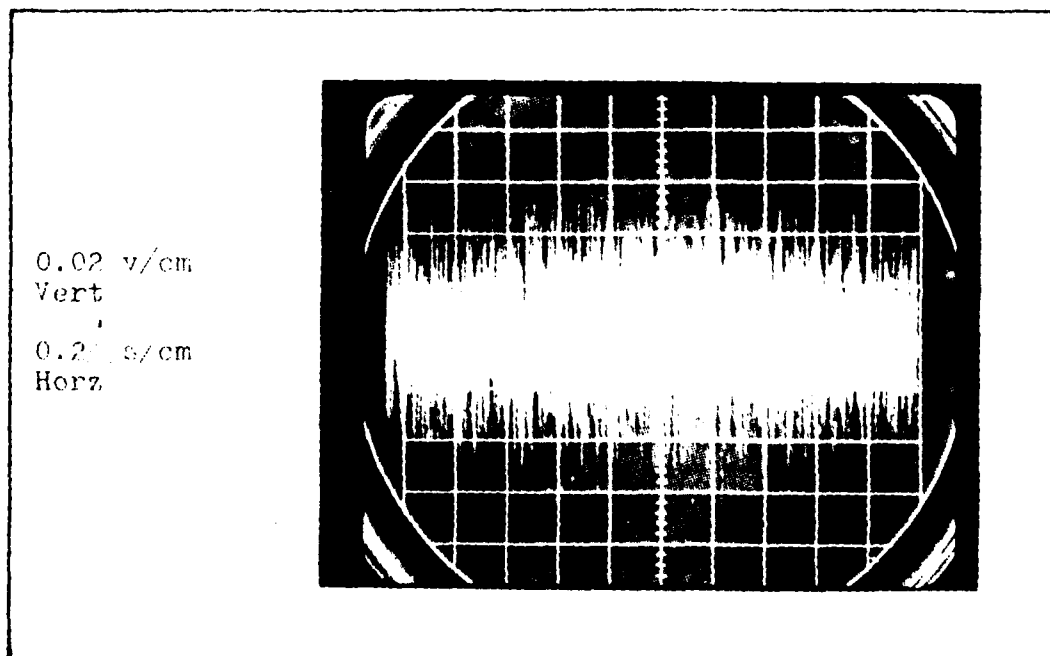

Figure 4.3 Noise from the LIA

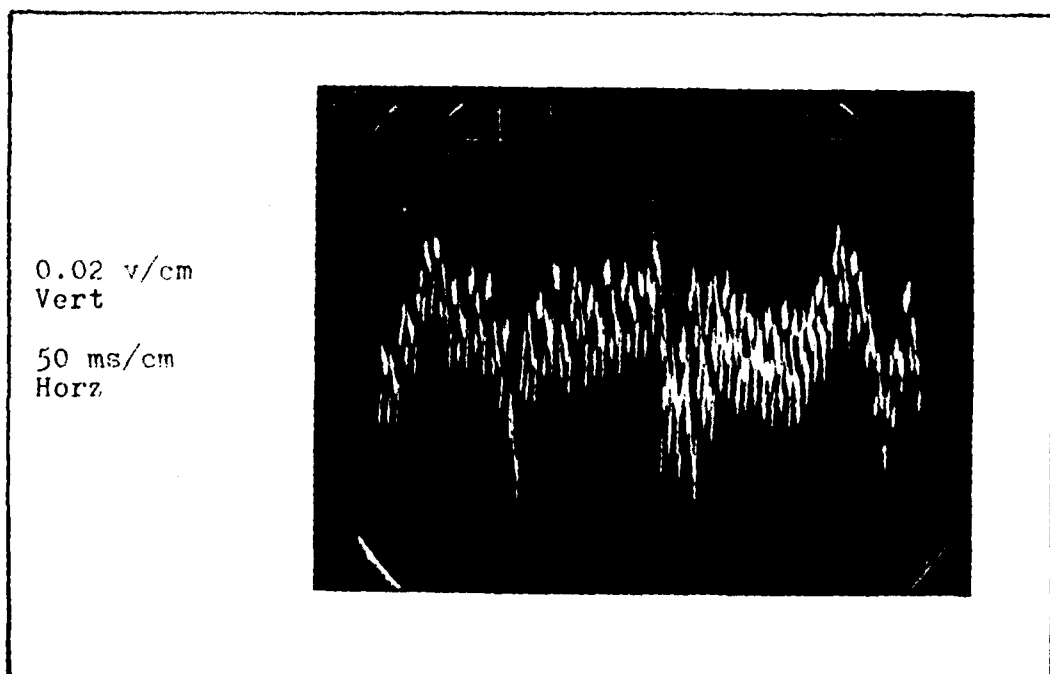
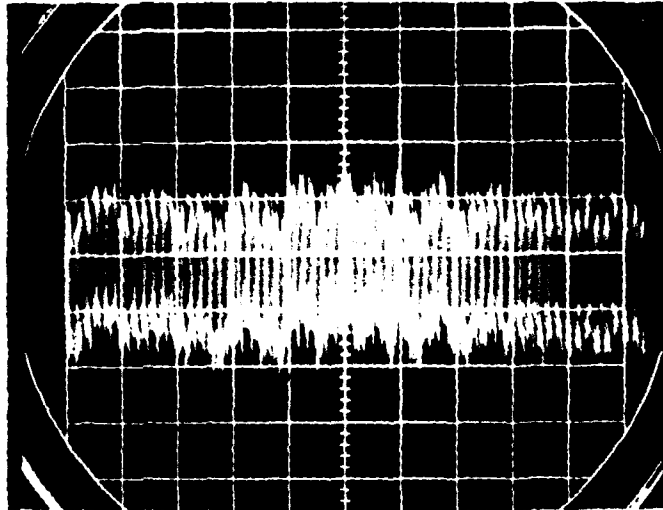

Figure 4.4 Noise from HVA1

0.02 v/cm  
Vert

0.1 ms/cm  
Horz



0.02 v/cm  
Vert

1 us/cm  
Horz

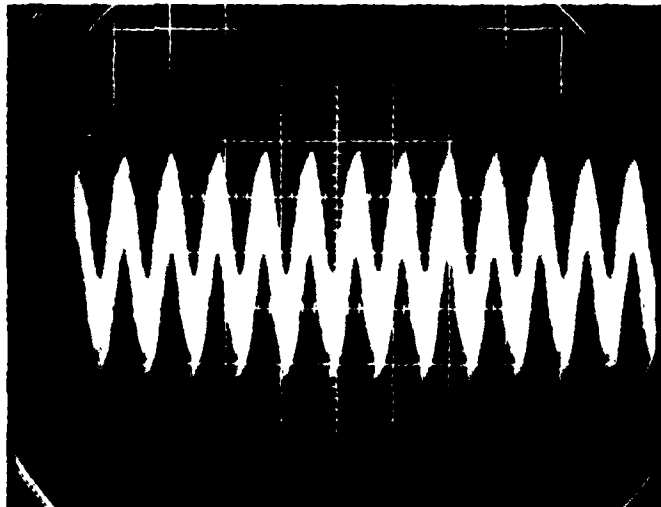
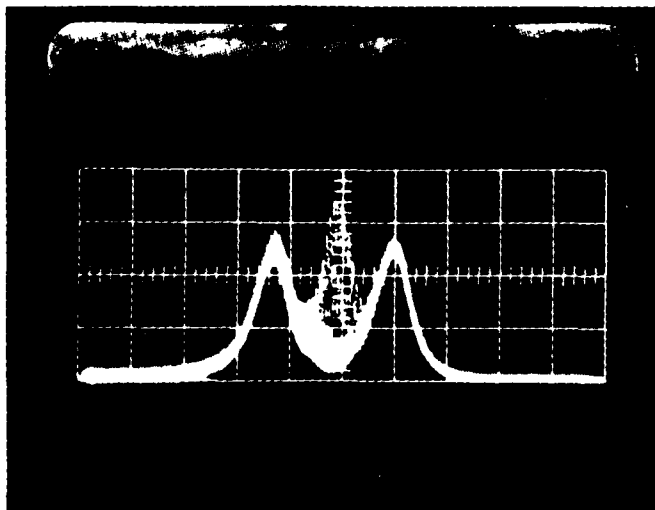

Figure 4.5 Noise from HVA<sub>2</sub>

0.0015 v/cm  
Vert

50 Hz/cm  
Horz



↑ 250 Hz

↑ 0 Hz

0.0015 v/cm  
Vert

200 Hz/cm  
Horz

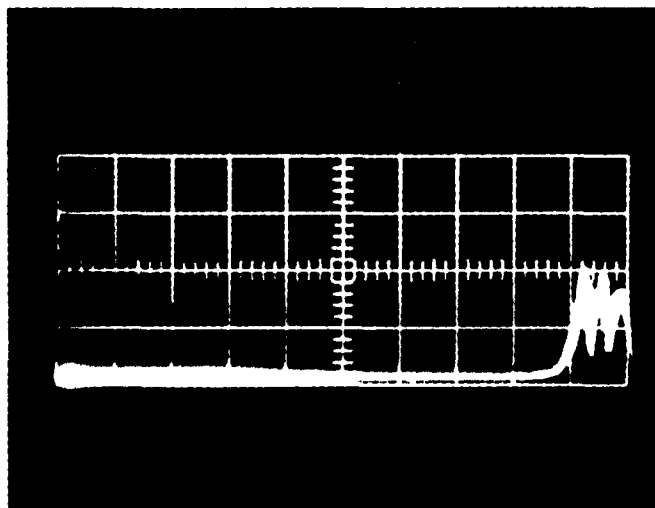

↑ 2 KHz

↑ 0 Hz

Figure 4.6 Spectral Content of Noise from the Interferometer Power Supply

0.002 v/cm  
Vert

50 Hz/cm  
Horz

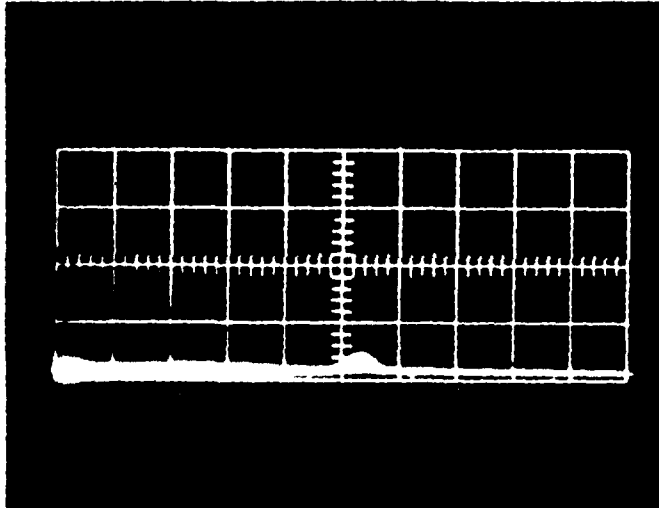

↑ 250 Hz

↑ 0 Hz

0.002 v/cm  
Vert

200 Hz/cm  
Horz

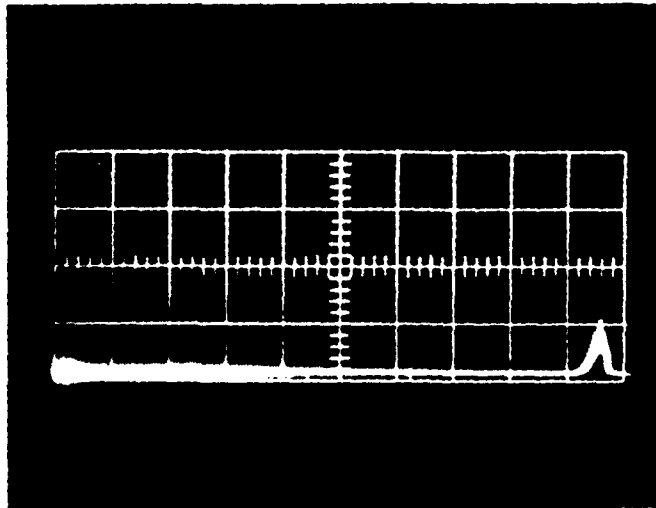

↑ 2 KHz

↑ 0 Hz

Figure 4.7 Spectral Content of Detector Noise with the Laser Blocked

0.024 v/cm  
Vert  
200 Hz/cm  
Horz

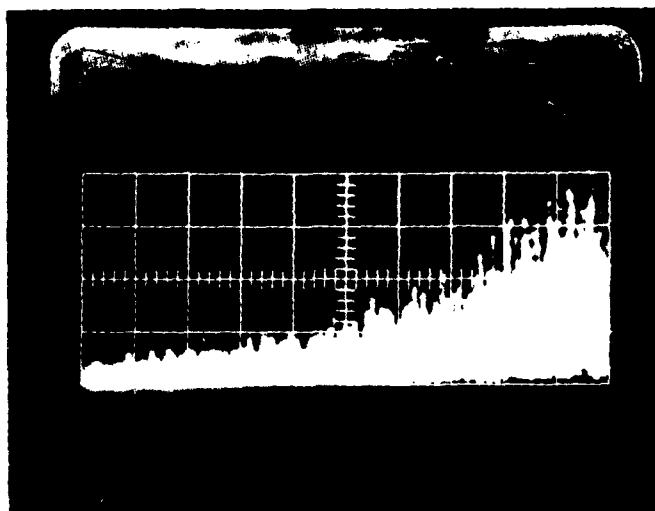
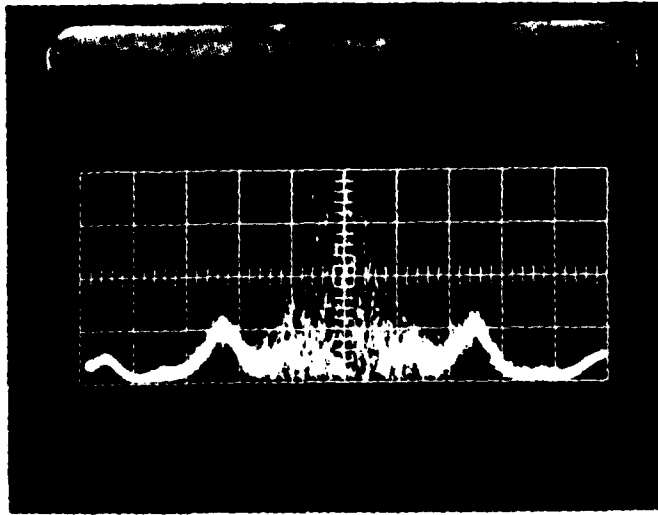

Figure 4.8 Spectral Content of Noise from the LIA

0.01 v/cm  
Vert

50 Hz/cm  
Horz



↑ 250 Hz

↑ 0 Hz

0.01 v/cm  
Vert

200 Hz/cm  
Horz

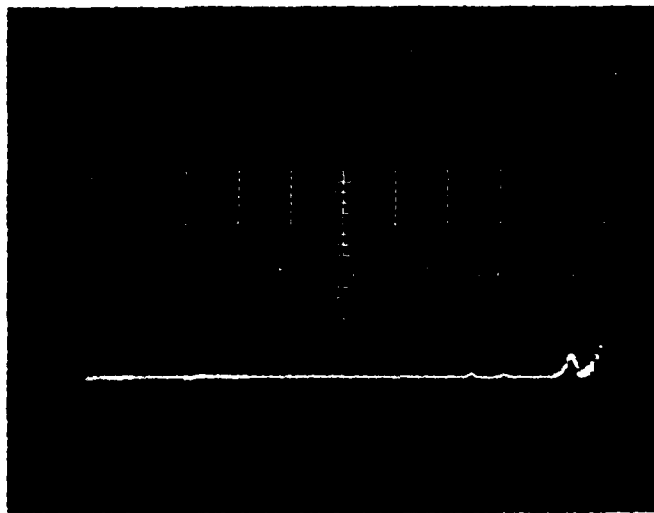

↑ 2 KHz

↑ 0 Hz

Figure 4.9 Spectral Content of HVA<sub>1</sub> Noise

0.014 v/cm  
Vert

50 Hz/cm  
Horz

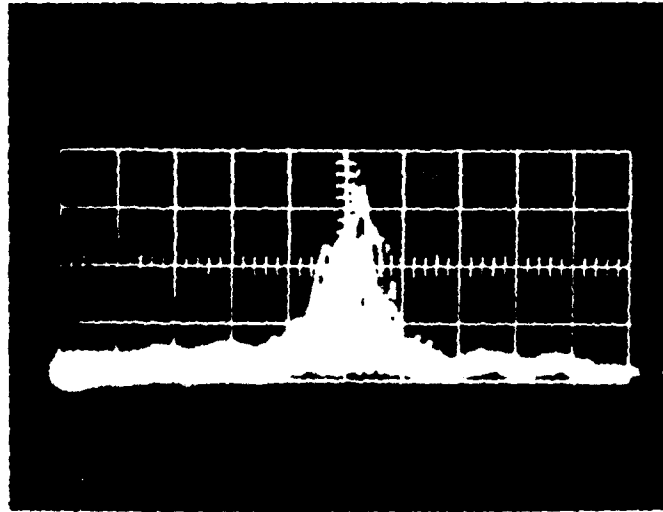

↑ 250 Hz

↑ 0 Hz

0.014 v/cm  
Vert

200 Hz/cm  
Horz

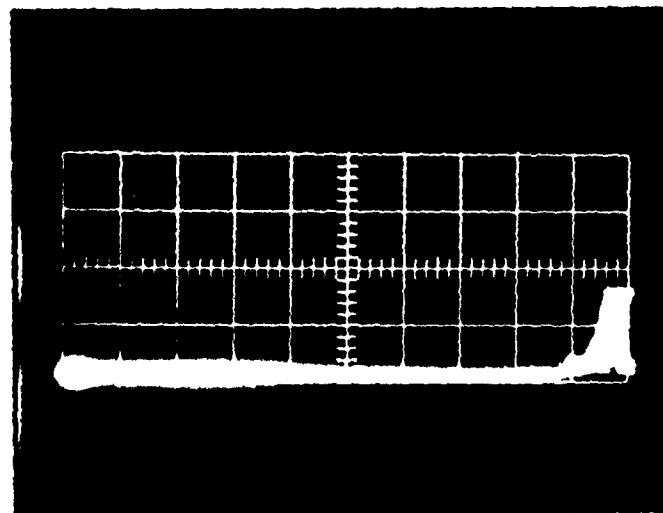

↑ 2 KHz

↑ 0 Hz

Figure 4.10 Spectral Content of HVA<sub>2</sub> Noise

## V System Model Parameters and Transfer Functions

### General Discussion

This chapter deals with solving the system model parameters. First the interferometer sensitivity is determined and is followed by the determination of PZT<sub>1</sub> and PZT<sub>2</sub> sensitivities. Next, the LIA constant is determined and the frequency characteristics are found for the LIA and HVA/PZT combinations.

### Interferometer Sensitivity ( $\Delta v_I$ )

The interferometer sensitivity,  $\Delta v_I$ , in MHz/volt, was determined using the equipment set-up shown in Figure 5.1. The interferometer resonance was matched to a laser mode by adjusting the interferometer's internal PZT with HVA<sub>2</sub>. When resonance was achieved, as indicated by a maximum voltage on the oscilloscope, the voltage setting of HVA<sub>2</sub> was recorded. HVA<sub>2</sub> was then slowly adjusted until a new interferometer resonance matched the next mode. The new voltage setting of HVA<sub>2</sub> was recorded and the difference between the two settings was determined. This experiment was performed several times for an average difference voltage of 55 volts. Since the laser mode spacing,  $\Delta v_M$ , from Eq (3.6) equals 375 MHz, the interferometer sensitivity becomes

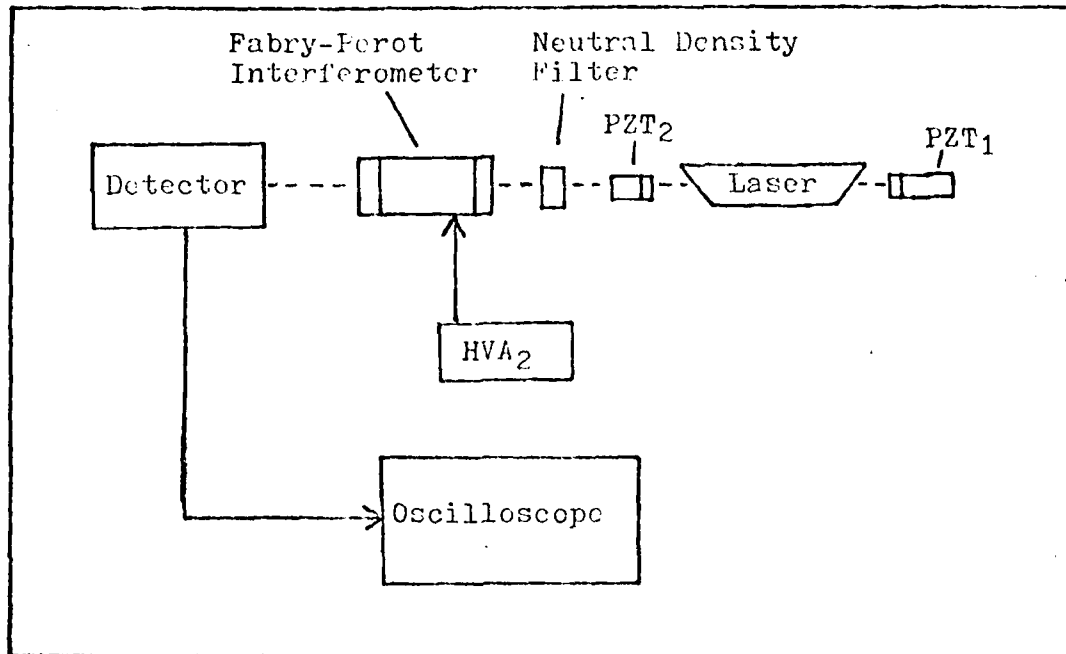

Figure 5.1 Block Diagram of the Interferometer Sensitivity Test

$$\Delta\nu_1 = \frac{375 \text{ MHz}}{55 \text{ v}}$$

$$= 682 \text{ MHz/volt} \quad (5.1)$$

#### PZT<sub>1</sub> Sensitivity ( $\Delta\nu_{\text{PZT}_1}$ )

The sensitivity of PZT<sub>1</sub>, in MHz/volt, was determined by scanning the laser output with the interferometer and observing the mode shift for a particular change in PZT<sub>1</sub> voltage. Figure 5.2 shows a pattern shift to the left of 1.1 cm for a change in HVA<sub>1</sub> voltage of 880 volts. The oscilloscope is calibrated to 150 MHz/cm by spreading the FSR over 10 cm. The mode shift then is 165 MHz which yields

0.05 v/cm  
Vert

150 MHz/cm  
Horz

HVA<sub>1</sub>=  
880 volts



0.05 v/cm  
Vert

150 MHz/cm  
Horz

HVA<sub>1</sub>=  
0 volts



Figure 5.2 PZT<sub>1</sub> Sensitivity

0.05 v/cm  
Vert  
150 MHz/cm  
Horz  
HVA1=  
622 volts

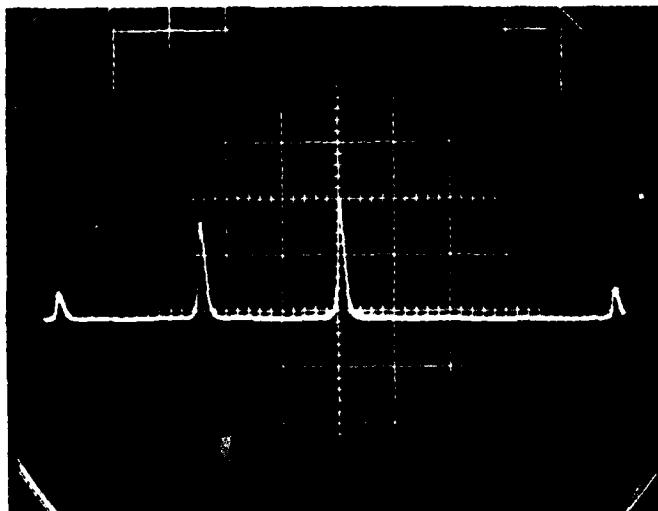

0.05 v/cm  
Vert  
150 MHz/cm  
Horz  
HVA1=  
0 volts

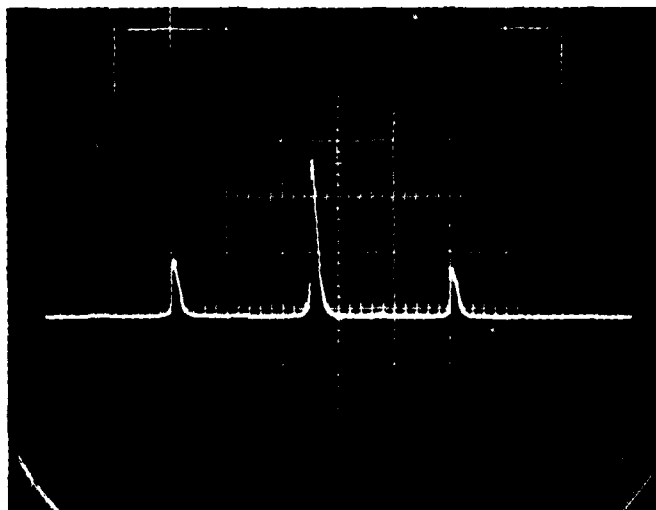

Figure 5.3 F2T<sub>2</sub> Sensitivity

$$\begin{aligned}\Delta\nu_{\text{PZT1}} &= \frac{165 \text{ MHz}}{880 \text{ v}} \\ &= 0.1875 \text{ MHz/volt}\end{aligned}\quad (5.2)$$

PZT<sub>2</sub> Sensitivity ( $\Delta\nu_{\text{PZT2}}$ )

The sensitivity of PZT<sub>2</sub> was found in the same manner as it was for PZT<sub>1</sub>. Figure 5.3 shows a 2 cm shift to the right for a 622 volt decrease in HVA<sub>2</sub> voltage. Thus, the mode shift is -300 MHz. Then

$$\begin{aligned}\Delta\nu_{\text{PZT2}} &= \frac{-300 \text{ MHz}}{622 \text{ v}} \\ &= -0.482 \text{ MHz/volt}\end{aligned}\quad (5.3)$$

The negative sign in Eq (5.3) was verified by several other experiments.

LIA Constant ( $K_{\text{LIA}}$ )

The LIA constant converts frequency to voltage across the LIA. A block diagram of the test set up to accomplish this is shown in Figure 5.4. The horizontal sweep voltage from the oscilloscope causes the laser output to sweep across the interferometer resonance. This produces an error signal out of the LIA that is routed to channel B of the chart recorder. The HVA<sub>1</sub> output is recorded on channel A with results shown in Figure 5.5. A linear section of the error signal from Figure 5.5 is matched

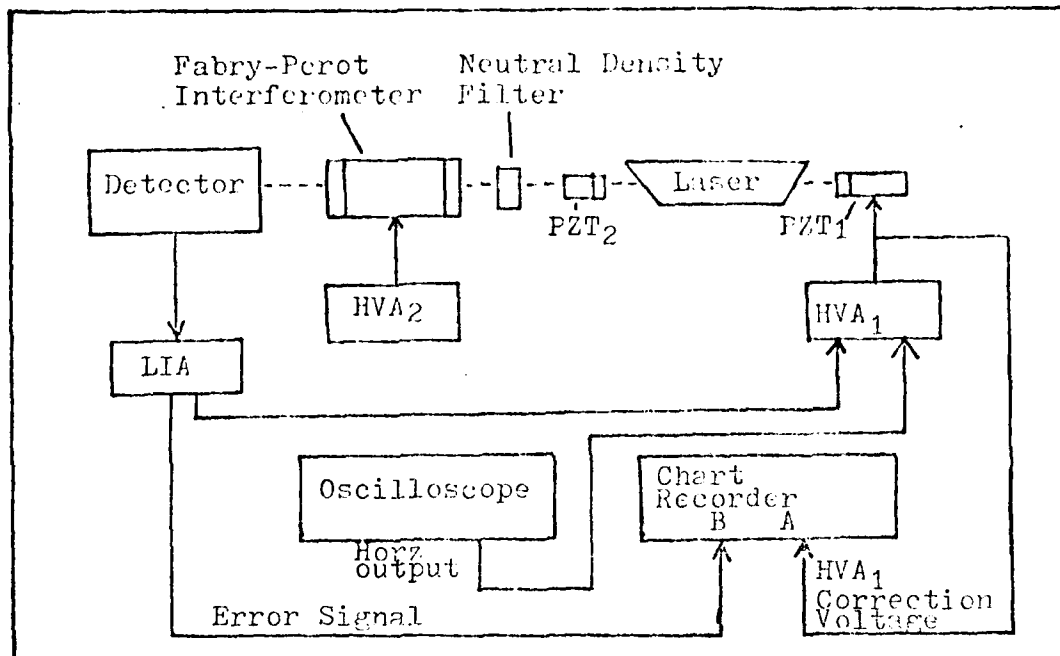

Figure 5.4 Block Diagram of the Test Scheme to Determine the LIA Constant

to the voltage ramp from channel A. As seen in Figure 5.5, a 4.0 volt sweep from HVA<sub>1</sub> causes a 9.0 volt change in the error signal. Using Eq (5.2) to convert the HVA<sub>1</sub> voltage to frequency, and solving for K<sub>LIA</sub>,

$$\begin{aligned}
 K_{LIA} &= \frac{9 \text{ volts}}{(4 \text{ volts})(\Delta V \text{ PZT1})} \\
 &= \frac{9 \text{ volts}}{(4 \text{ volts})(0.1875 \text{ MHz/volt})} \\
 &= 12 \text{ volts/MHz} \quad (5.4)
 \end{aligned}$$

During this measurement the LIA Sensitivity was set to 500  $\mu$ v, the REF ATTN was set to 0.1v calibrated, and

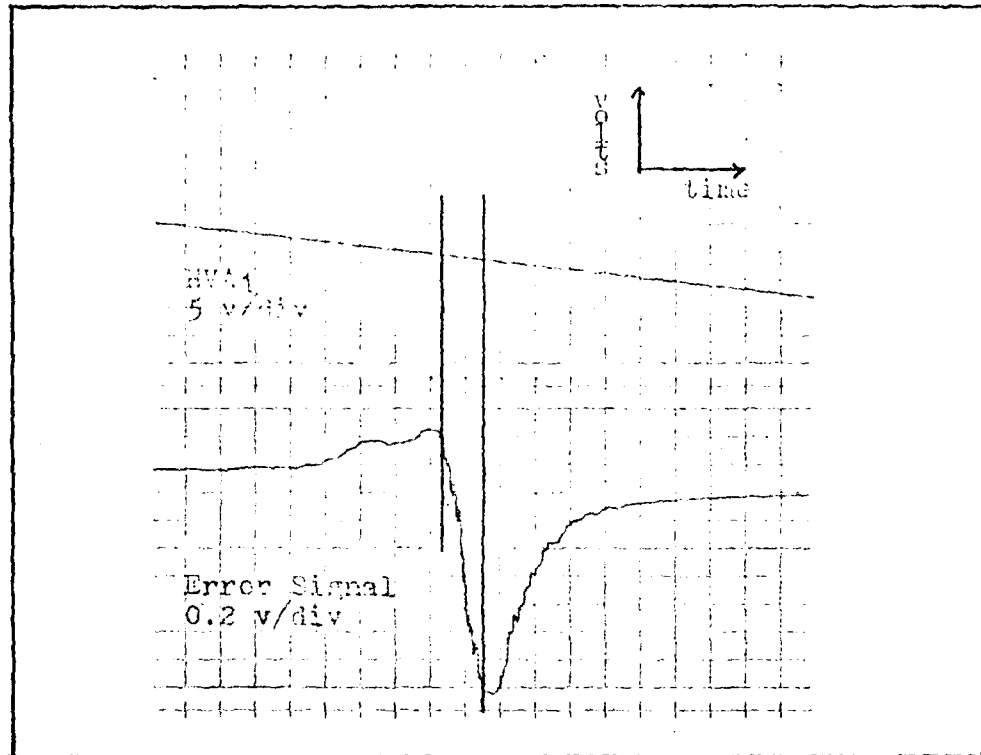

Figure 5.5 Results of the Laser Scan for Determination of the LIA Constant

the detector signal peaked at 0.2 volts. The REF ATTN setting is always kept at 0.1v, however, the other parameters are subject to change so a general equation for  $K_{LIA}$  is

$$K'_{LIA} = (12 \text{ v/MHz}) \left[ \frac{V_d}{0.2 \text{ v}} \cdot \frac{500 \times 10^{-6}}{LIA_s} \right]$$

$$= (0.03) \left[ \frac{V_d \text{ volts/MHz}}{LIA_s} \right] \quad (5.5)$$

where  $V_d$  is the detector voltage and  $LIA_s$  is the LIA sensitivity setting.

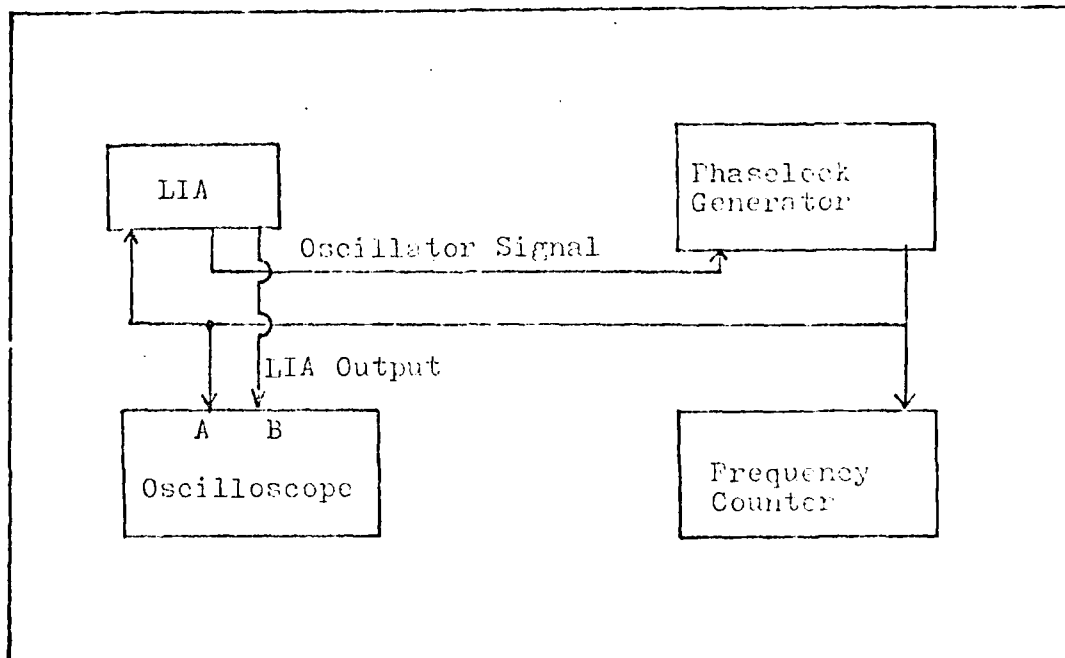

Figure 5.6 Block Diagram of Equipment Scheme used to Determine LIA Frequency Response

#### LIA Frequency Analysis and Transfer Function

Figure 5.6 is a block diagram of the equipment scheme used to determine the frequency characteristics of the LIA. The LIA oscillator signal was set to 41 KHz and modulated by the phase-lock generator with a variable modulation frequency. The LIA output was then compared in phase and amplitude to the phase-lock generator output using the oscilloscope shown in Figure 5.6. The frequency response of the LIA is shown in Figure 5.7.

The transfer function in radians/sec, which includes  $K'_{LIA}$  from Eq (5.5), is

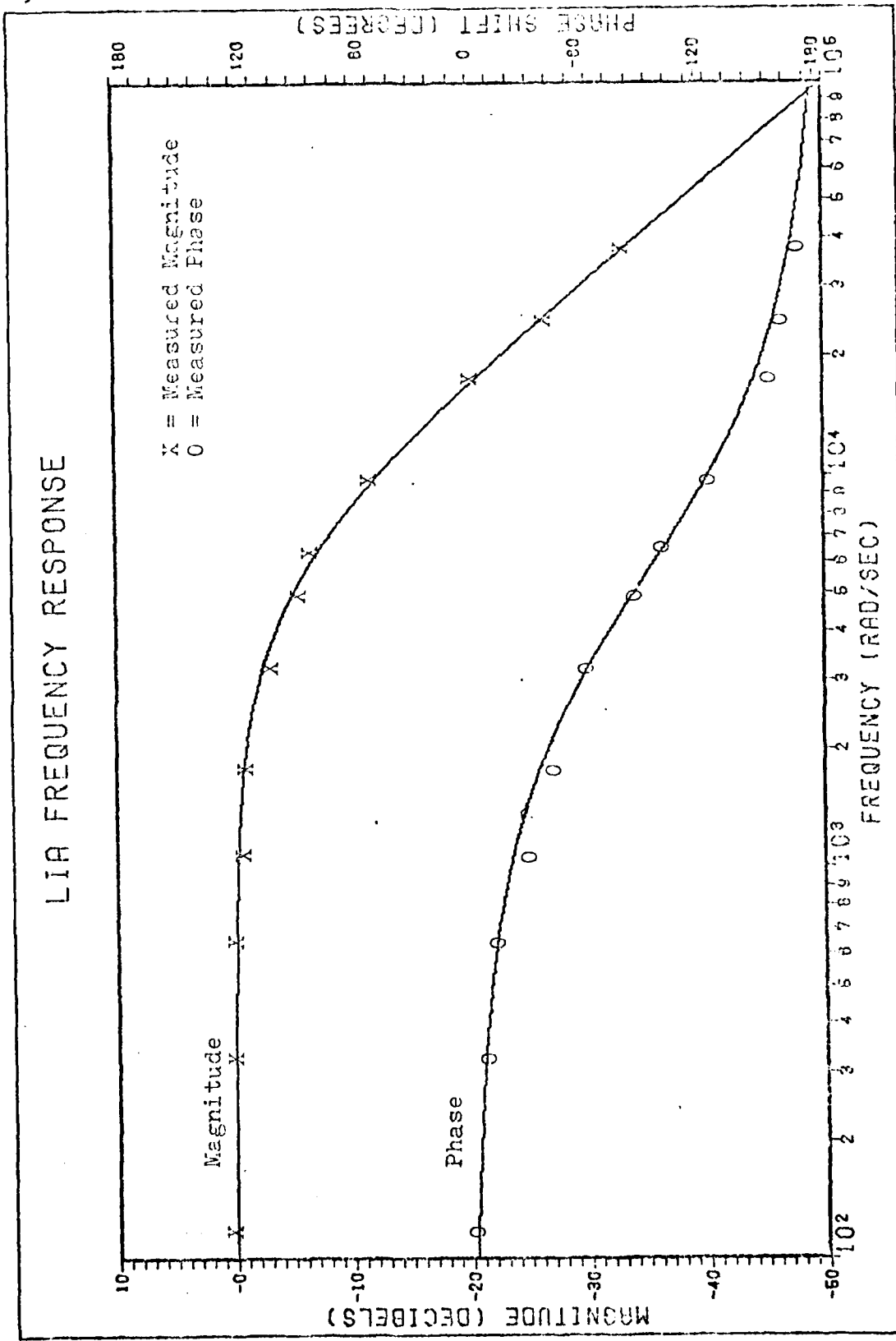

Figure 5.7 LIA Frequency Response

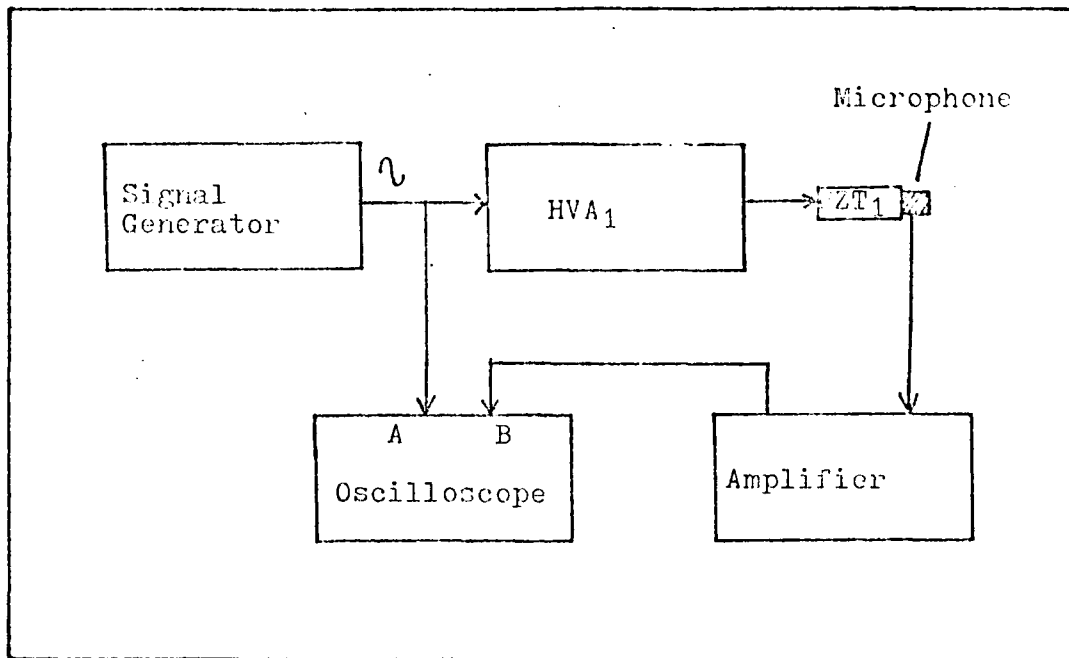

Figure 5.8 Frequency Analysis of HVA<sub>1</sub>/PZT<sub>1</sub> Combination Using a Condenser Microphone

$$G_{LIA} = \frac{K'_{LIA}}{(s+5654)^2}$$

$$= \frac{(0.03)(V_0/LIA_0 \text{ V/MHz})}{(s+5654)^2} \quad (5.6)$$

#### HVA<sub>1</sub>/PZT<sub>1</sub> Frequency Analysis and Transfer Function

In order to determine the frequency response for PZT<sub>1</sub>, HVA<sub>1</sub> had to be used, therefore, the frequency response for the HVA<sub>1</sub>/PZT<sub>1</sub> combination was determined using the test scheme shown in Figure 5.8.

The frequency response of the HVA<sub>1</sub>/PZT<sub>1</sub> combination was estimated by comparing the magnitude and phase of the

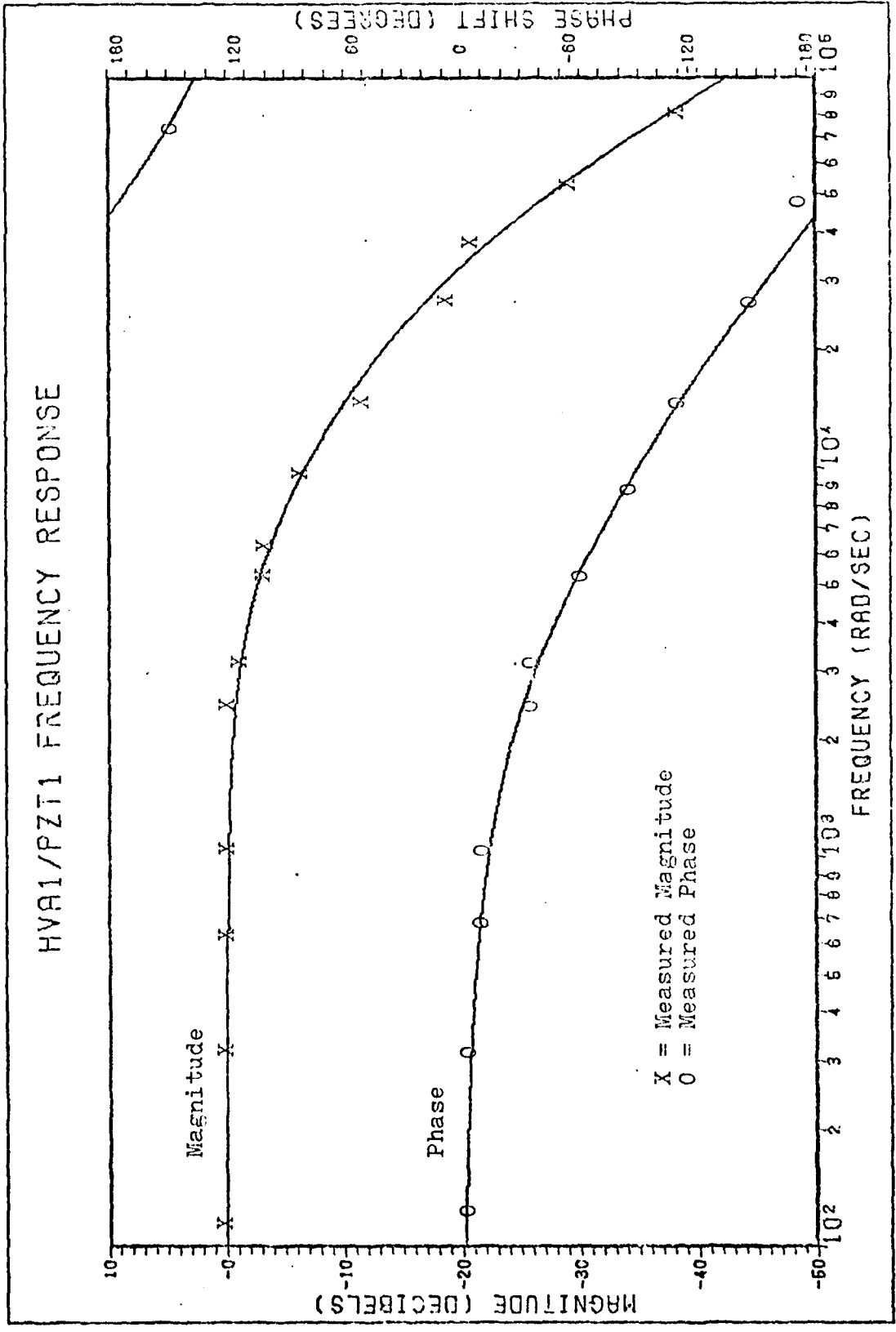

Figure 5.9 HVA1/PZT1 Frequency Response

microphone output signal to the oscillator signal on the oscilloscope as the signal generator frequency was increased.

From the results the frequency response of the HVA<sub>1</sub>/PZT<sub>1</sub> combination was determined and is shown in Figure 5.9.

The transfer function for the HVA<sub>1</sub>/PZT<sub>1</sub> combination was approximated as

$$\begin{aligned}
 G_{HVA1/PZT1} &= \frac{(K_{HVA1})(\Delta V_{PZT1})}{(s+5655)(s+38956)^2} \\
 &= \frac{(K_{HVA1})(0.1875 \text{ MHz/volt})}{(s+5655)(s+38956)^2} \quad (5.7)
 \end{aligned}$$

where  $K_{HVA1}$  is the variable gain setting of HVA<sub>1</sub> and  $\Delta V_{PZT1}$  is the PZT<sub>1</sub> sensitivity taken from Eq (5.2).

#### HVA<sub>2</sub>/PZT<sub>2</sub> Frequency Analysis and Transfer Function

The combined frequency response of HVA<sub>2</sub>/PZT<sub>2</sub> was determined in the same manner as it was for HVA<sub>1</sub>/PZT<sub>1</sub>. The estimated frequency response for HVA<sub>2</sub>/PZT<sub>2</sub> is shown in Figure 5.10.

The transfer function for the HVA<sub>2</sub>/PZT<sub>2</sub> combination, is

$$\begin{aligned}
 G_{HVA2/PZT2} &= \frac{(K_{HVA2})(\Delta V_{PZT2})}{(s+3142)(s+119380)^2} \\
 &= \frac{(K_{HVA2})(-0.482 \text{ MHz/volt})}{(s+3142)(s+119380)^2} \quad (5.8)
 \end{aligned}$$

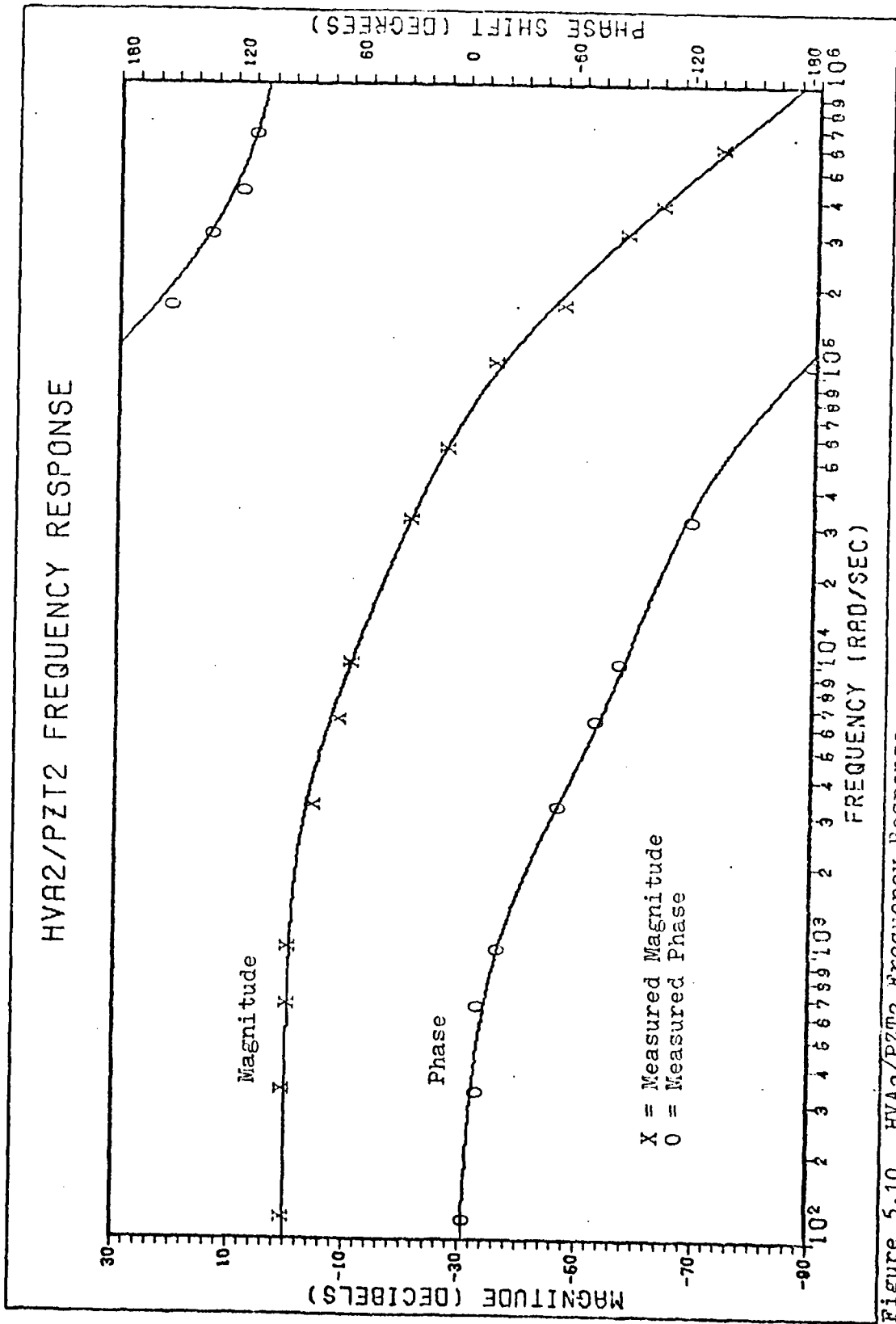

Figure 5.10 HVA2/PZT2 Frequency Response

where  $K_{HVA_2}$  is the variable gain setting of  $HVA_2$  and  $PZT_2$  is the  $PZT_2$  sensitivity from Eq (5.3).

## VI Compensator Design

### General Discussion

Two compensators were designed for use with control method I and a third was designed for use with method II. The first compensator was designed using only steady-state analysis. The second compensator is more sophisticated and was designed using frequency analysis for a closed loop bandwidth of 2.0 KHz. The third compensator was also designed using frequency analysis for a closed loop bandwidth of 2.0 KHz. In the design of the third compensator, the compensator in the PZT<sub>1</sub> loop was designed first for a closed loop bandwidth of 100 Hz neglecting the presence of the loop to PZT<sub>2</sub>. This low bandwidth is well within the limits that a longer PZT would have put on the system. The compensator in the loop to PZT<sub>2</sub> was then designed taking into account the design of the other loop. The system models from Figures 2.2 and 2.4 are redrawn in Figures 6.1 and 6.2 to include the transfer function of each component as found in Chapter V. Design of compensator  $G_{c1}$  for variation 1 of control method II is shown in the next section.

### Compensator $G_{c1}(s)$ for Variation 1 of Control Method I Using Steady State Analysis

The open loop transfer function,  $G_{c1}(s)$ , for the

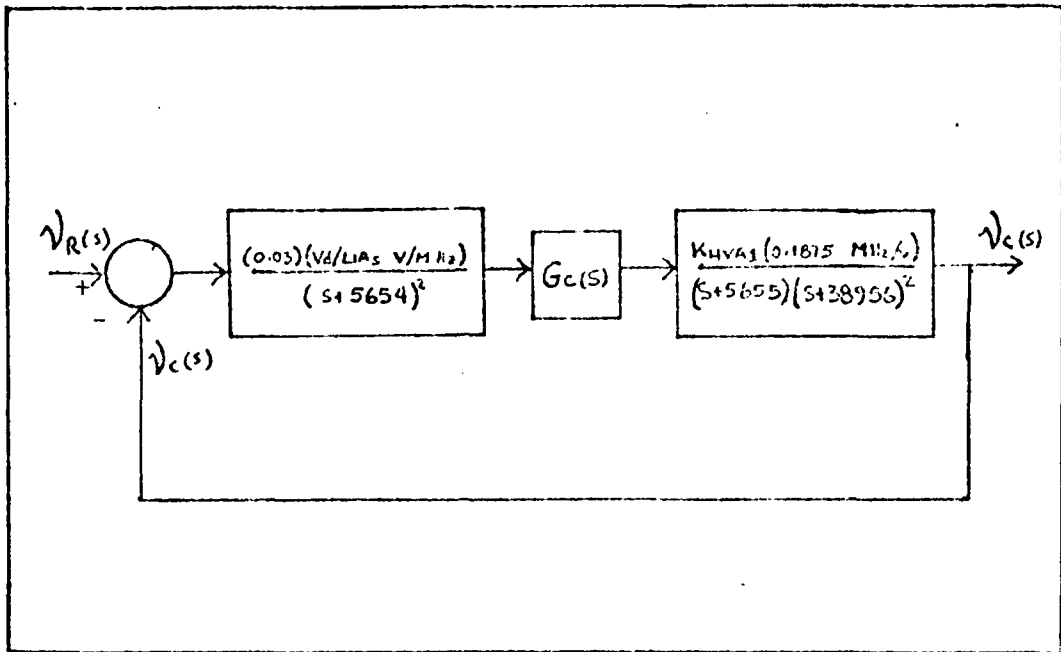

Figure 6.1 System Model for Control Method I With Transfer Functions

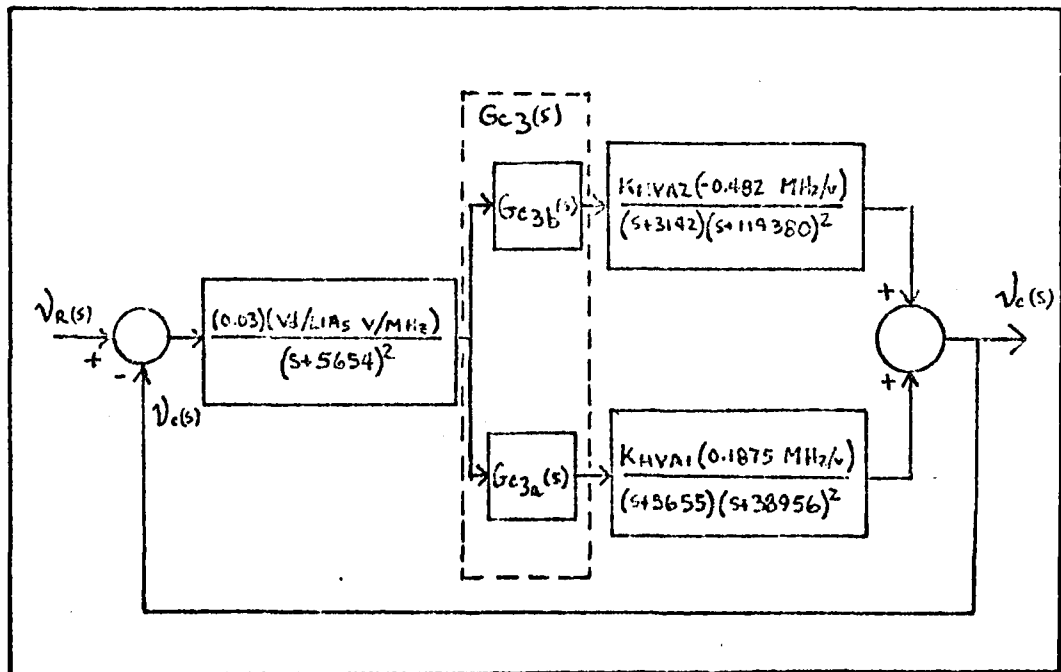

Figure 6.2 System Model for Control Method II With Transfer Functions

system shown in Figure 6.1, without the compensator is

$$G_{X1}(s) = \frac{K_{X1}}{(s+5655)^3(s+38956)^2} \quad (6.1)$$

where

$$K_{X1} = \frac{(0.0056)(V_d)(K_{HVA1})}{LIA_S} \quad (6.2)$$

For most measurements  $V_d = 0.23v$ ,  $K_{HVA1} = 100$ , and  $LIA_S = 500 \times 10^{-6}$ , then

$$K_{X1} = 257 \quad (6.3)$$

To design for a steady-state error equal to zero for a step input, the theory shown by D'Azzo and Houpis is used where (Ref 7:177)

$$e(t)_{ss} = \lim_{s \rightarrow 0} [sE(s)] = 0 \quad (6.5)$$

The control ratio for the loop shown in Figure 6.1 is

$$\frac{V_C(s)}{V_R(s)} = \frac{G_{X1}(s) G_{C1}(s)}{1 + G_{X1}(s) G_{C1}(s)} \quad (6.6)$$

where

$$V_C(s) = E(s) G_X(s) \quad (6.7)$$

Substituting  $V_c(s)$  from Eq (6.7) into Eq (6.6) and solving for  $E(s)$  yields:

$$E(s) = \frac{V_R(s)}{1 + G_{X1}(s) G_{C1}(s)} \quad (6.8)$$

where for a step input of magnitude 1

$$V_R(s) = \frac{1}{s} \quad (6.9)$$

Thus Eq (6.8) can be written as

$$E(s) = \frac{1}{s [1 + G_{X1}(s) G_{C1}(s)]} \quad (6.10)$$

Substituting Eq (6.10) into Eq (6.5) yields

$$\begin{aligned} e(t)_{ss} &= \lim_{s \rightarrow 0} \frac{s}{s [1 + G_{X1}(s) G_{C1}(s)]} \\ &= \lim_{s \rightarrow 0} \frac{1}{1 + G_{X1}(s) G_{C1}(s)} \end{aligned} \quad (6.11)$$

Replacing  $G_{X1}(s)$  with Eq (6.1) and setting  $e(t)_{ss}$  equal to zero results in the following :

$$0 = \lim_{s \rightarrow 0} \frac{(s+5655)^3 (s+38956)^2 G_{C1} D(s)}{(s+5655)^3 (s+38956)^2 G_{C1} D(s) + K_{X1} G_{C1} N(s)} \quad (6.12)$$

where  $G_{C1}N(s)$  and  $G_{C1}D(s)$  are the numerator and denominator of  $G_{C1}(s)$ . For this equation to hold true,  $G_{C1}D(s)$

must contain a zero at the origin of the s plane, thus a first choice for the compensator is

$$G_{c1}(s) = \frac{K_{c1}}{s} \quad (6.13)$$

where  $K_{c1}$  is the compensator constant. The open loop transfer function including  $G_{c1}(s)$  becomes

$$G'_{x1}(s) = \frac{K_{x1} K_{c1}}{(s)(s+5655)^3 (s+38956)^2} \quad (6.14)$$

Using  $K_{x1} = 257$  from Eq (6.3), thus yields the result

$$G'_{x1}(s) = \frac{257 K_{c1}}{(s)(s+5655)^3 (s+38956)^2} \quad (6.15)$$

To get an idea of the amount of gain achievable, a computer assisted root locus was generated as shown in Figure 6.3. An expansion of the branch starting at  $s=0$  indicates that for a damping ratio of 0.7,

$$K_{c1} = 3.46 \times 10^{18} \quad (6.16)$$

This value was used to generate the system open loop and closed loop frequency response plots shown in Figures 6.4 and 6.5.

From the open loop frequency plot of Figure 6.4, the system is seen to have about a 60db gain margin which shows it is very stable. The closed loop frequency

ROOT LOCUS: SINGLE PZT, COMPENSATOR FROM SS ANYL

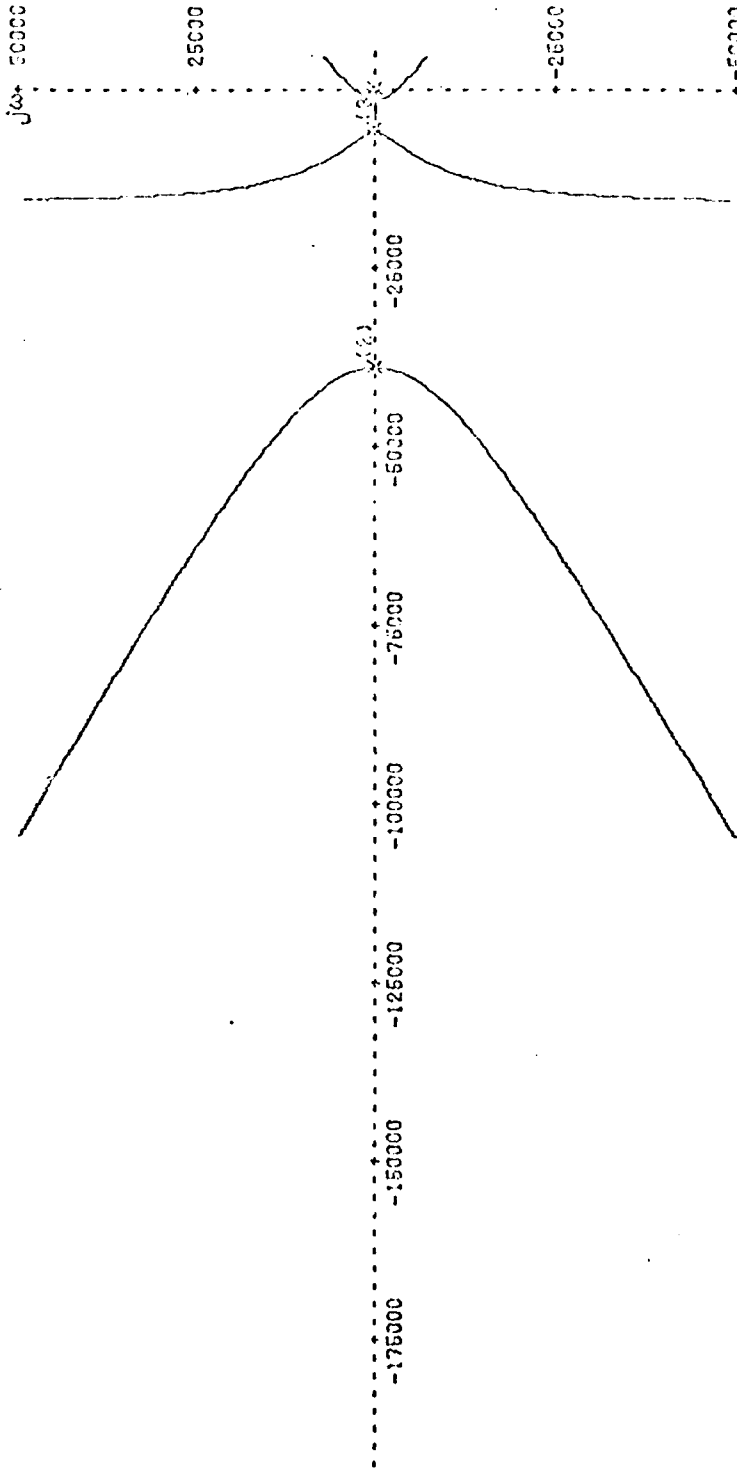

$$CLTF(S) = \frac{K}{S(S+5825)^2(S+39956)^2}$$

Figure 6.3 System Root Locus. Variation 1 of Control Method I. Using Compensator Cc1

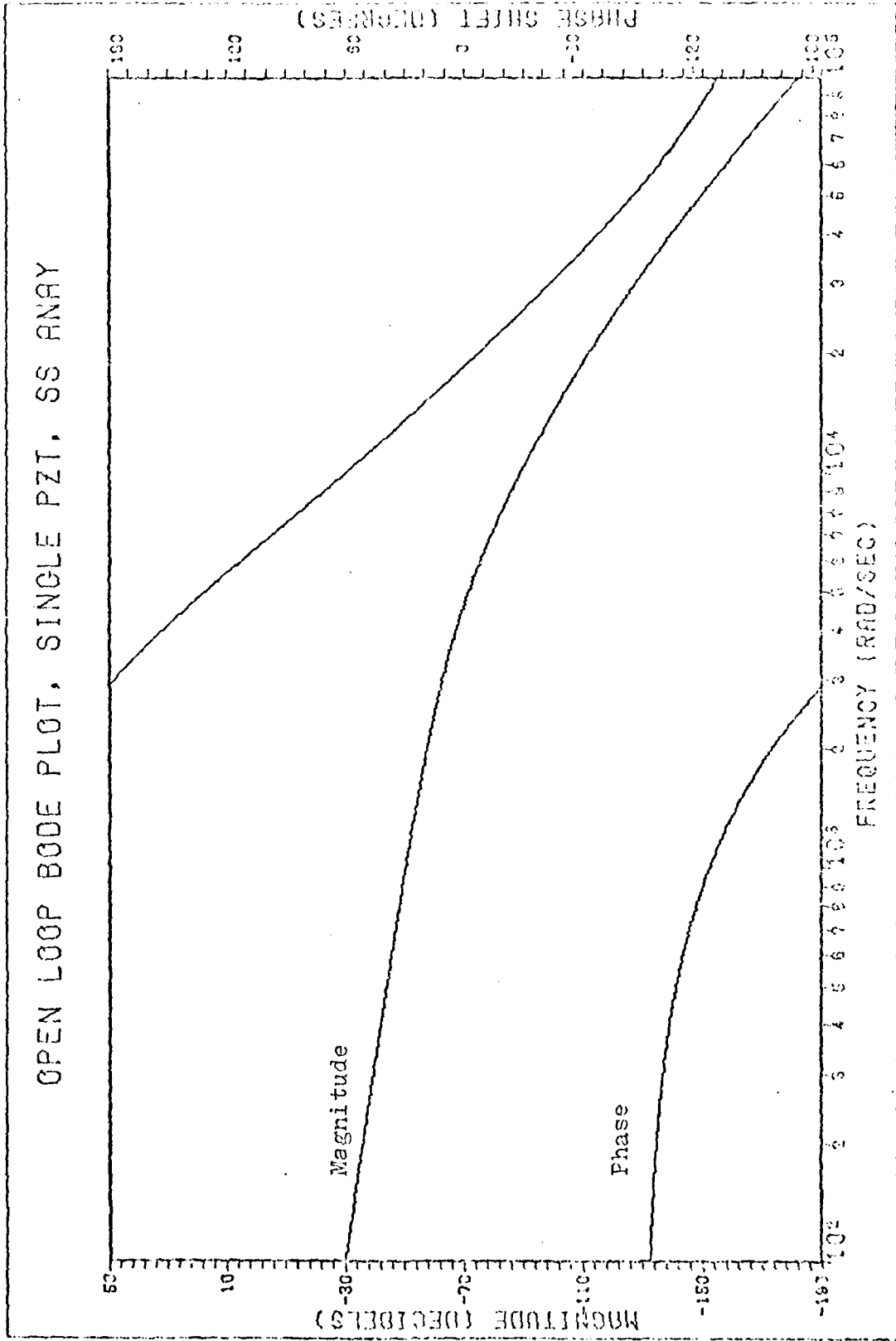

Figure 6.4 Open Loop Frequency Response. Variation 1 of Control Method 1, Using Compensator Gc1

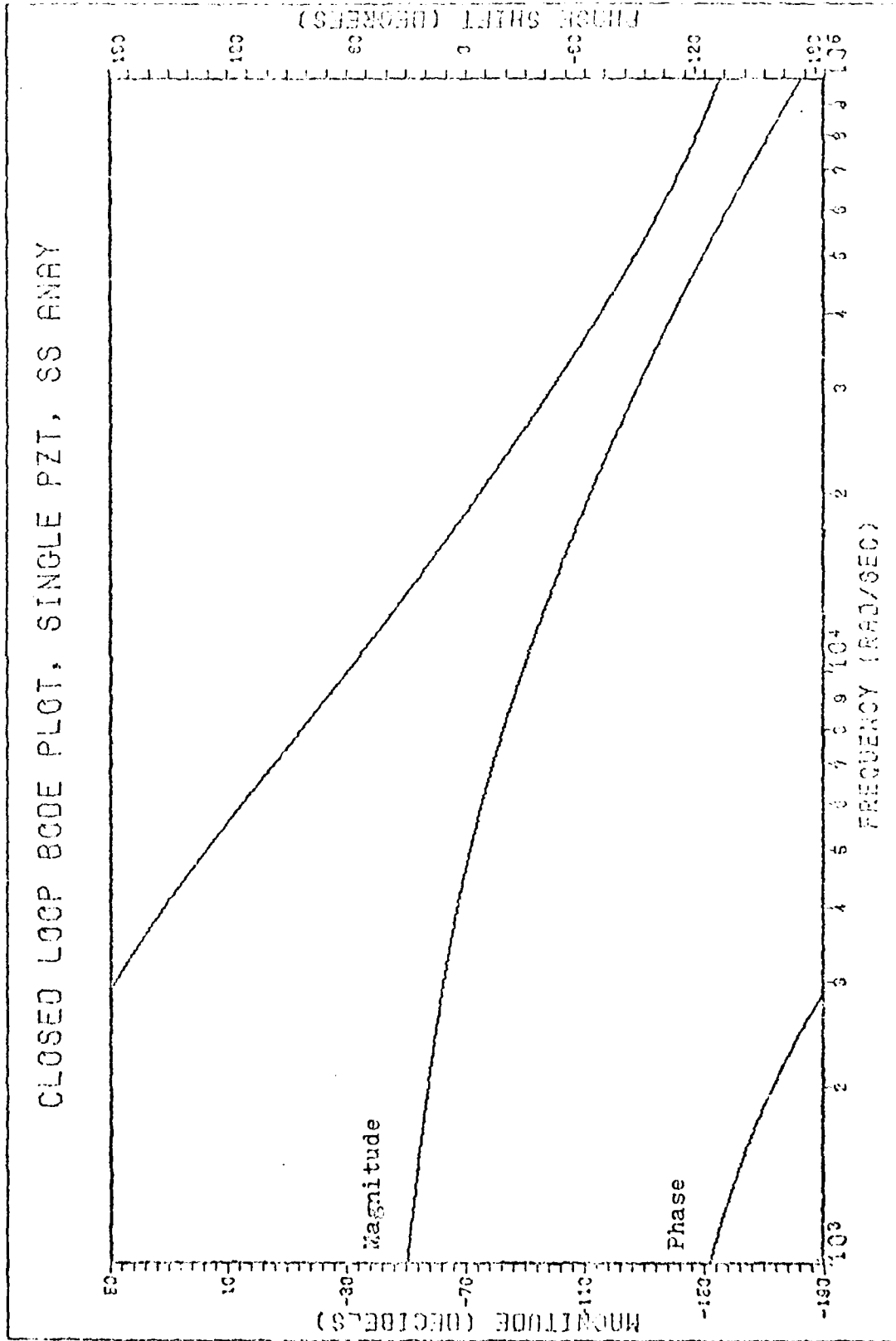

Figure 6.5 Closed Loop Frequency Response, Variation 1 of Control Method 1, Using Compensator  $G_{c1}$

response shown in Figure 6.5 shows a 20 db/decade drop for low frequencies with a break frequency at about 2.0 KHz as would be expected.

The compensator circuit design was implemented using operational amplifiers as shown in Appendix B. The design of compensator  $G_{c2}$  for use with variation 2 of control method I is covered in the following section.

Compensator  $G_{c2}(s)$  for Variation 2 of Control Method I  
Using Frequency Analysis

The desired bandwidth of the closed loop system is 2.0 KHz. The Guileman-Truxal procedure as explained by D'Azzo and Houpis is followed during the design of this compensator (Ref 7:408).

The control ratio,  $M_2(s)$ , for the system shown in Figure 6.1 is

$$M_2(s) = \frac{V_c(s)}{V_R(s)} = \frac{N_2(s)}{D_2(s)} = \frac{G_{c2}(s) G_{x1}(s)}{1 + G_{c2}(s) G_{x1}(s)} \quad (6.17)$$

where  $N_2(s)$  and  $D_2(s)$  are the desired control ratio numerator and denominator respectively. For a bandwidth of 2.0 KHz and a 20 db/decade roll-off with four nondominant poles, the control ratio can be rewritten as

$$M_2(s) = \frac{N_2(s)}{D_2(s)} = \frac{K_{m2}}{(s+12560)(s+75000)(s+80000)(s+105000)(s+190000)} \quad (6.18)$$

The constant  $K_{m2}$  required for a control ratio of unity for zero steady-state error is found by taking the limit of  $M_2(s)$  as  $s$  approaches zero and setting it equal to unity. So,

$$1 = \lim_{s \rightarrow 0} M_2(s) = \lim_{s \rightarrow 0} \frac{K_{m2}}{(s+12560)(s+75000)(s+80000)(s+85000)(s+90000)}$$

$$= \frac{K_{m2}}{5.76 \times 10^{23}} \quad (6.19)$$

thus,

$$K_{m2} = 5. \times 10^{23} \quad (6.20)$$

Solving Eq (6.17) for  $G_{c2}(s)$  yields (Ref 7:408):

$$G_{c2}(s) = \frac{N_2(s)}{[D_2(s) - N_2(s)] G_{x1}(s)} \quad (6.21)$$

Using Eqs (6.1) and (6.18) to solve for  $G_{c2}(s)$  results in the following:

$$G_{c2}(s) = \frac{K_{m2}(s+5655)^3(s+38956)^2}{[(s+12560)(s+75000)(s+80000)(s+85000)(s+90000) - K_{m2}] K_{x1}} \quad (6.22)$$

Expanding the denominator, using Eq (6.20) and factoring the results, Eq (6.22) becomes

$$G_{c2}(s) = \frac{5.7 \times 10^{23} (s+5655)^3 (s+38956)^2}{K_{x1}(s)(s+52440 \pm j46400)(s+118800 \pm j31080)} \quad (6.23)$$

The compensator is further simplified by setting the damping ratio equal to 1.0 which moves the poles to the real axis for ease of implementation.

$$G_{c2}(s) = \frac{5.7 \times 10^{23} (s+5600)^3 (s+38900)^2}{K_{x1} (s)(s+70021)^2 (s+122800)^2} \quad (6.24)$$

Using Eq (6.3) to substitute for  $K_{x1}$  yields

$$G_{c2}(s) = \frac{2.2 \times 10^{21} (s+5600)^2 (s+38900)^2}{(s)(s+70021)^2 (s+122800)^2} \quad (6.25)$$

The open loop transfer function then becomes

$$G''_{x1}(s) = \frac{5.7 \times 10^{23} (s+5600)^3 (s+38900)^2}{(s)(s+70021)^2 (s+122800)^2 (s+5600)^3 (s+38956)^2} \quad (6.26)$$

A root locus plot is shown in Figure 6.6. Figures 6.7 and 6.8 show the system open and closed loop frequency response plots. The frequency plots were generated using the numerator constant shown in Eq (6.25). Note that the gain margin in Figure 6.7 is about 17 db indicating a stable system. The closed loop frequency response shown in Figure 6.8 is flat with a breakpoint at about 2.0 KHz as designed.

This compensator circuit design was also implemented using operational amplifiers and is shown in Appendix C. The design of compensator  $G_{c3}$  for use with control method II is covered in the following section.

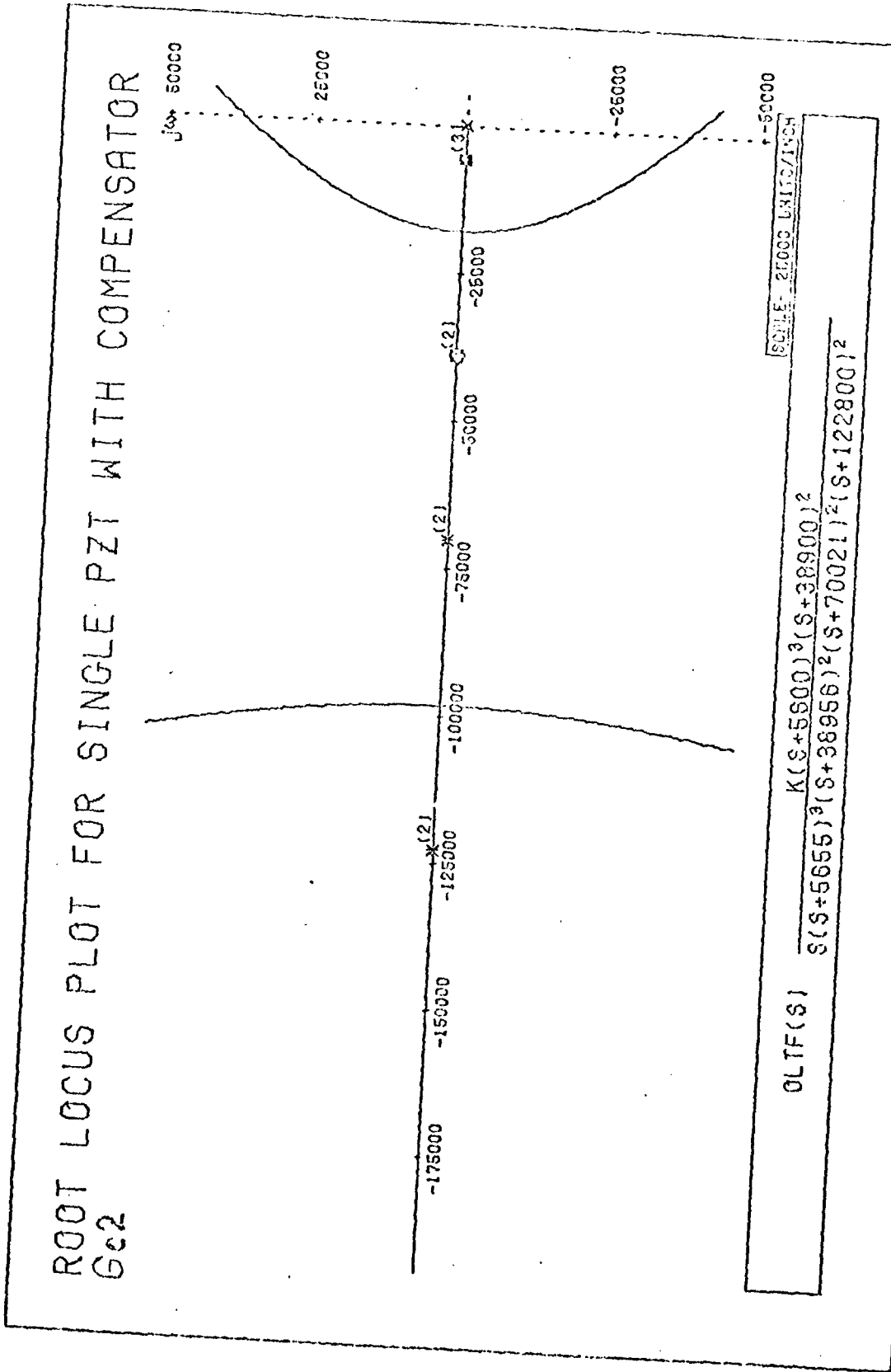

Figure 6.6 System Root Locus. Variation 2 of Control Method I, Using Compensator Gc2

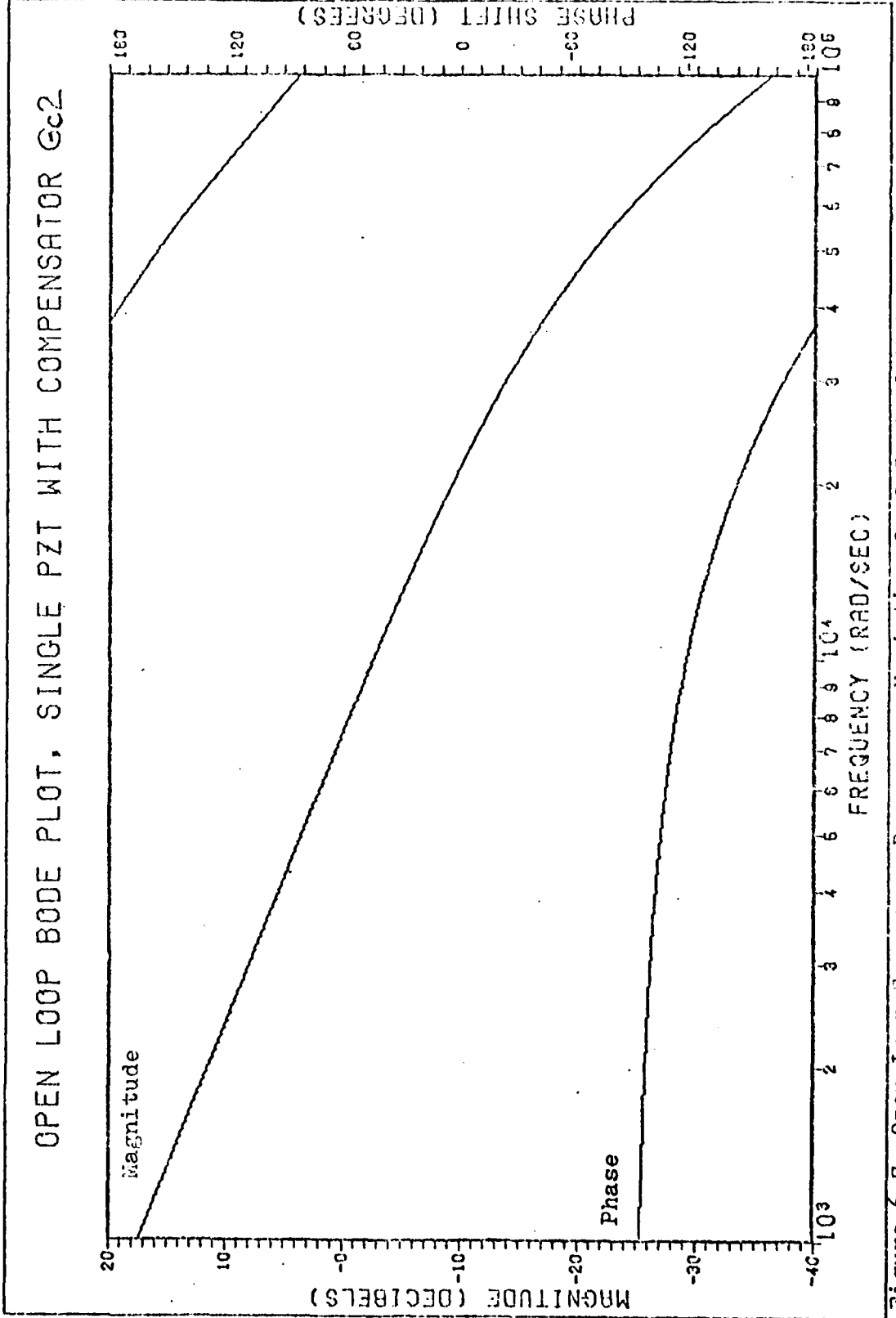

Figure 6.7 Open Loop Frequency Response. Variation 2 of Control Method I, Using Compensator Gc2

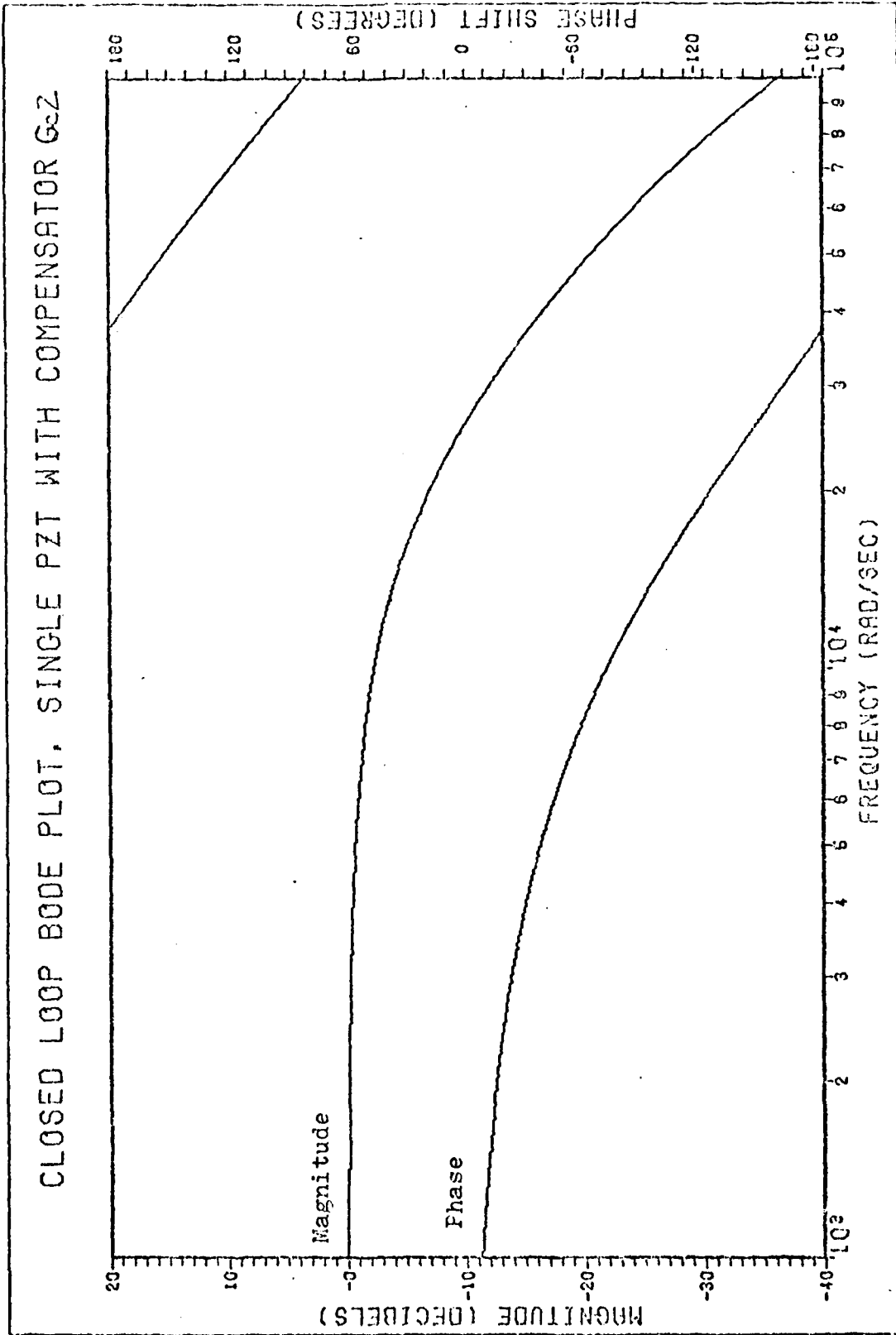

Figure 6.8 Closed Loop Frequency Response. Variation 2 of Control Method I, Using Compensator  $G_{c2}$

Compensator  $G_{c3}(s)$  for Control Method II Using Frequency Analysis

The compensator  $G_{c3}(s)$  is designed in two steps. First, the loop to PZT<sub>2</sub> is ignored and a compensator,  $G_{c3a}(s)$ , is designed for a closed loop bandwidth of 100 Hz with a 40 db roll-off and a 0.6 damping coefficient. Using Figure 6.1, and the same procedure as used in the last section, the closed loop control ratio is

$$M_{3a}(s) = \frac{N_{3a}(s)}{D_{3a}(s)} = \frac{K_{m3a}}{(s^2 + 691s + 394384)(s + 4000)(s + 45000)(s + 50000)} \quad (6.27)$$

where  $M_{3a}(s)$  is the control ratio of Figure 6.1 using  $G_{c3a}(s)$  in place of  $G_c(s)$ .  $N_{3a}(s)$  and  $D_{3a}(s)$  are the desired numerator and denominator of  $M_{3a}(s)$ . The constant  $K_{m3a}$  required for a control ratio of one to achieve zero steady-state error is found using the same method as in the previous section. Then,

$$K_{m3a} = 3.5 \times 10^{19} \quad (6.28)$$

Using Eq (6.21), the equation for compensator  $G_{c3a}(s)$  is,

$$G_{c3a}(s) = \frac{N_{3a}(s)}{[D_{3a}(s) - N_{3a}(s)] G_{x1}(s)} \quad (6.29)$$

Using Eqs (6.27) and (6.1) to substitute for  $N_{3a}(s)$ ,  $D_{3a}(s)$ , and  $G_{x1}(s)$ , the compensator equation becomes

$$G_{c3a}(s) = \frac{3.5 \times 10^{19} (s+5655)^3 (s+38756)^2}{[(s^2+671s+394384)(s+40500)(s+45500)(s+5000) - 3.5 \times 10^{19}] K_{x1}} \quad (6.30)$$

Expanding Eq (6.30) and factoring the results, the compensator becomes

$$G_{c3a}(s) = \frac{3.5 \times 10^{19} (s+5655)^3 (s+38756)^2}{K_{x1} (s)(s+719)(s+49740)(s+39550)(s+45690)} \quad (6.31)$$

$G_{c3a}(s)$  is simplified by cancelling nondominant poles and zeros which leaves

$$G_{c3a}(s) = \frac{3.5 \times 10^{19} (s+5600)^3}{K_{x1} (s)(s+719)(s+49740)} \quad (6.32)$$

The second part of compensator  $G_{c3}(s)$  is designed using  $G_{c3a}(s)$  of Eq (6.32) and the system diagram from Figure 6.2. The desired closed loop bandwidth is 2 KHz with a 20 db/decade roll-off. The desired closed loop transfer function with four nondominant poles is

$$\frac{N_3(s)}{D_3(s)} = \frac{K_{m3}}{(s+12560)(s+120000)(s+125000)(s+130000)(s+135000)} \quad (6.33)$$

For zero steady state error, the numerator constant must be

$$K_{m3} = 3.3 \times 10^{24} \quad (6.34)$$

If  $G_{X2}(s)$  is the open loop transfer function of the system, then the system control ratio,  $M_3(s)$ , is

$$M_3(s) = \frac{G_{X2}(s)}{1 + G_{X2}(s)} \quad (6.35)$$

where  $G_{X2}(s)$  includes both compensators  $G_{c3a}(s)$  and  $G_{c3b}(s)$ . Solving for  $G_{X2}(s)$  using Figure 2.4,

$$G_{X2}(s) = \left[ G_{LIA}(s) \right] \left[ \frac{G_{c3b}N(s)}{G_{c3b}D(s)} G_{HVA2/P2T2}(s) + G_{c3a}(s) G_{HVA1/P2T1}(s) \right] \quad (6.36)$$

where  $G_{c3b}N(s)$  and  $G_{c3b}D(s)$  are the numerator and denominator of  $G_{c3b}(s)$ .  $G_{c3b}(s)$  can be found by substituting Eq (6.36) into Eq (6.35) and setting the results equal to Eq (6.33). We then get

$$G_{c3b}(s) = \frac{5 \times 10^{21} (s+665)(s+3142)(s+5606)^2 (s+33400 \pm j1786)(s+49907)(s+118900 \pm j0.0187)}{(s)^2 (s+719)(s+38960)^2 (s+49760)(s+83760 \pm j63030)(s+177500 \pm j43630)} \quad (6.37)$$

The compensator is simplified so that  $G_{c3b}(s)$  becomes

$$G_{c3b}(s) = \frac{5 \times 10^{21} (s+3142)(s+5606)^2}{(s)(s+83760 \pm j63030)} \quad (6.38)$$

Again, a damping factor of unity is used to move the poles to the real axis for ease of implementation so the final design of  $G_{c3b}(s)$  is

$$G_{c3b}(s) = \frac{5 \times 10^{21} (s+3142)(s+5606)^2}{(s)(s+104833)^2} \quad (6.39)$$

The system open loop transfer function  $G_{X2}(s)$  becomes

$$G_{X2}(s) = \frac{3.1 \times 10^{25} (s+74)(s+500)^2 (s+38110)(s+39810)(s+49710)}{(s)(s+719)(s+5655)^2 (s+38960 \pm j0.02837)(s+477+0)(s+119400 \pm j0.3267)(s+104700 \pm j0.341)}$$

(6.40)

This derivation assumes HVA gain settings of 100, LIAs = 500 mv, and  $V_d = 0.23v$

A root locus plot is shown in Figure 6.9. Figure 6.10 and 6.11 show the system open-loop and closed-loop frequency response plots. As seen in Figure 6.9 the root locus plot shows an improvement over both of the plots previously seen. The open loop frequency response, as shown in Figure 6.10, shows a phase margin of about 10.0 db which indicates that the system is stable. The degree of stability is less however than for method I as seen by comparing Figures 6.11, 6.5, and 6.8. The closed loop frequency response from Figure 6.11 is flat to about 2.0 KHz as was designed. The circuit design of the compensator,  $G_{C3}$ , is shown in Appendix D.

#### Final Design of Each Compensator

Figure 6.12 shows all three compensators taken from equations 6.13, 6.25, 6.32, and 6.39 respectively.

# ROOT LOCUS PLOT FOR METHOD II, COMPENSATOR GC3

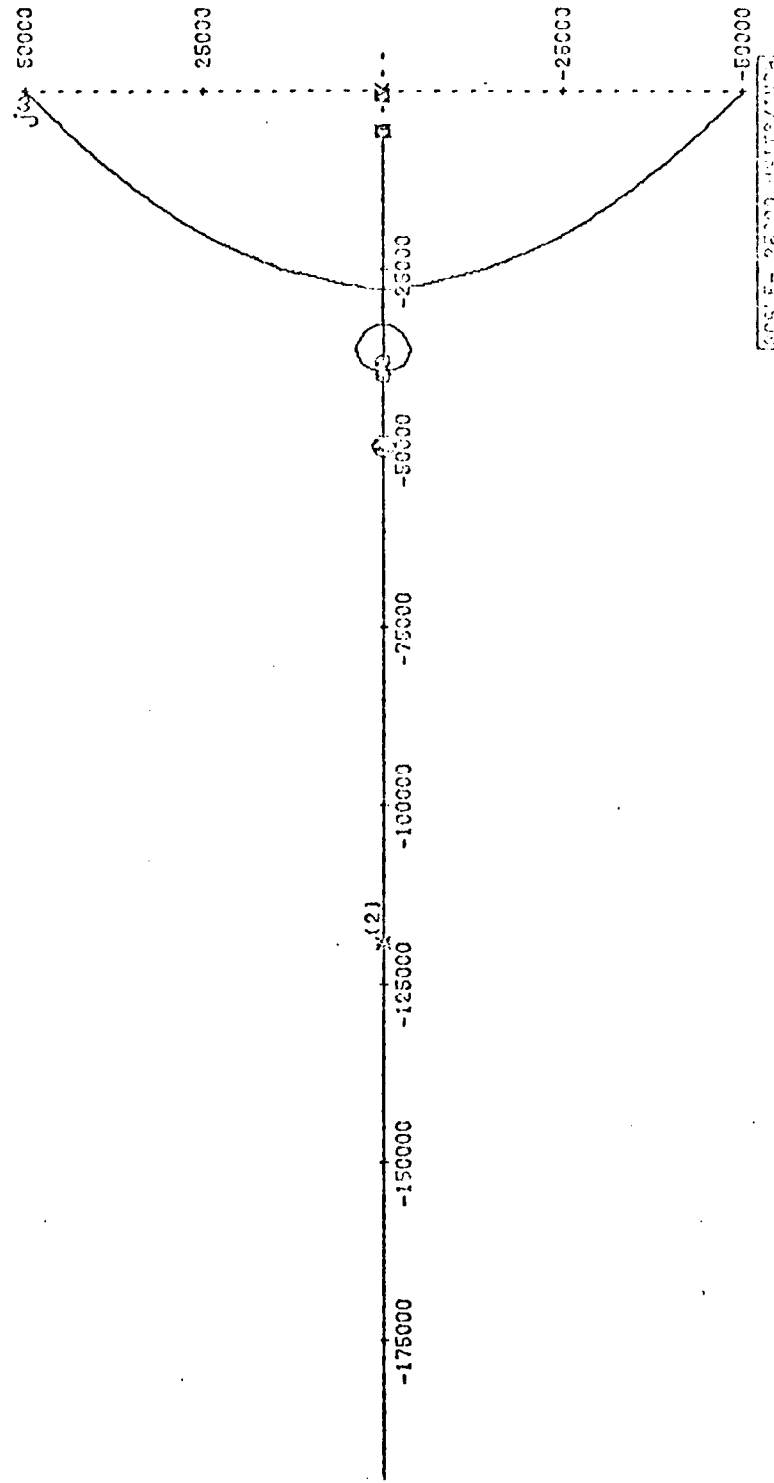

THE OPEN LOOP TRANSFER FUNCTION IS

$$G(s)E(s) = \frac{25000(s+175000)}{s(s+719)(s+5055)(s+49740)(s+116470)(s^2+113763s+3133716.011)(s^2+77206s+1517091300.004)(s^2+167820s+10330516800)}$$

Figure 6.9 System Root Locus. Control Method II Using Compensator Gc3

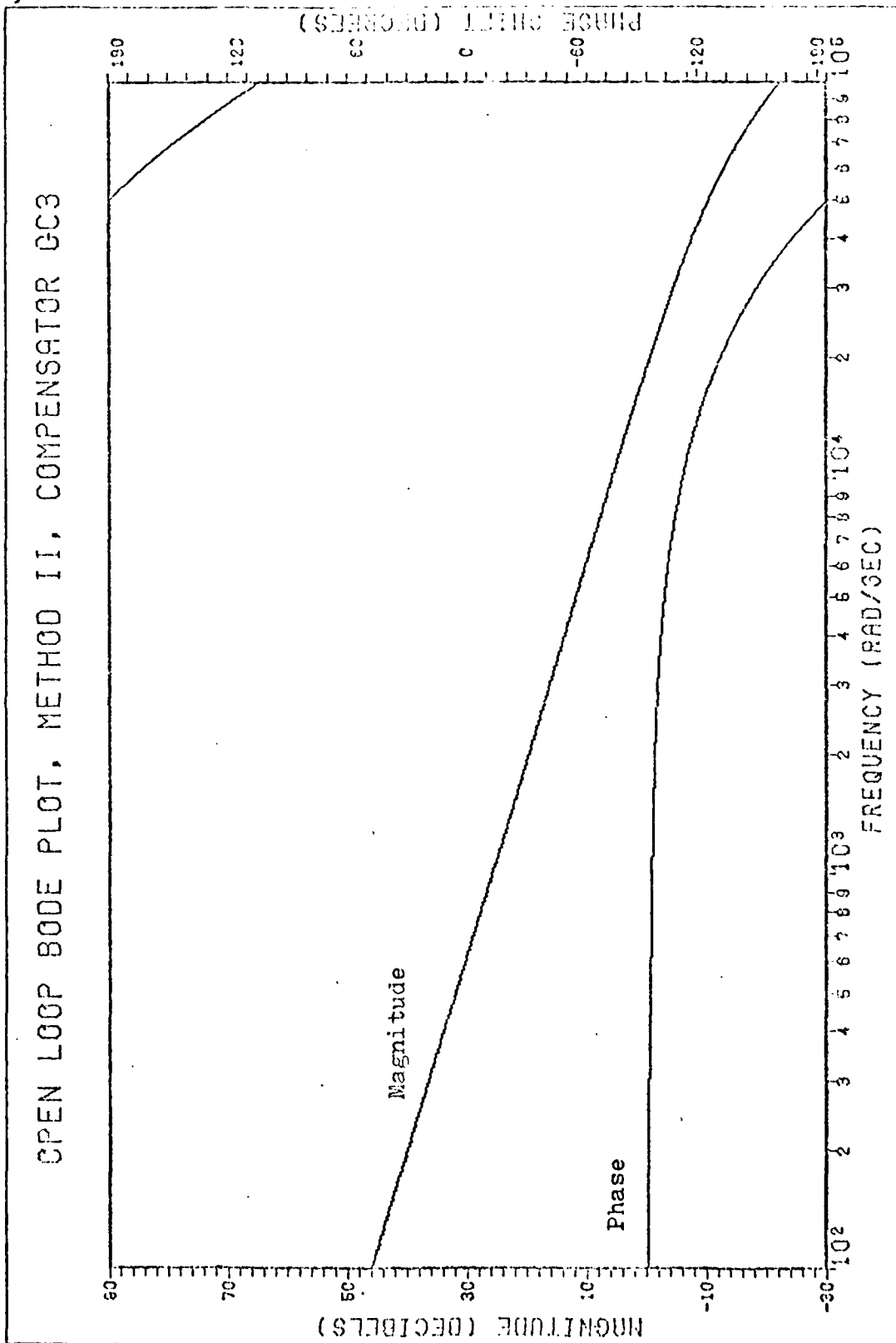

Figure 6.10 Open Loop Frequency Response. Control Method II Using Compensator GC3

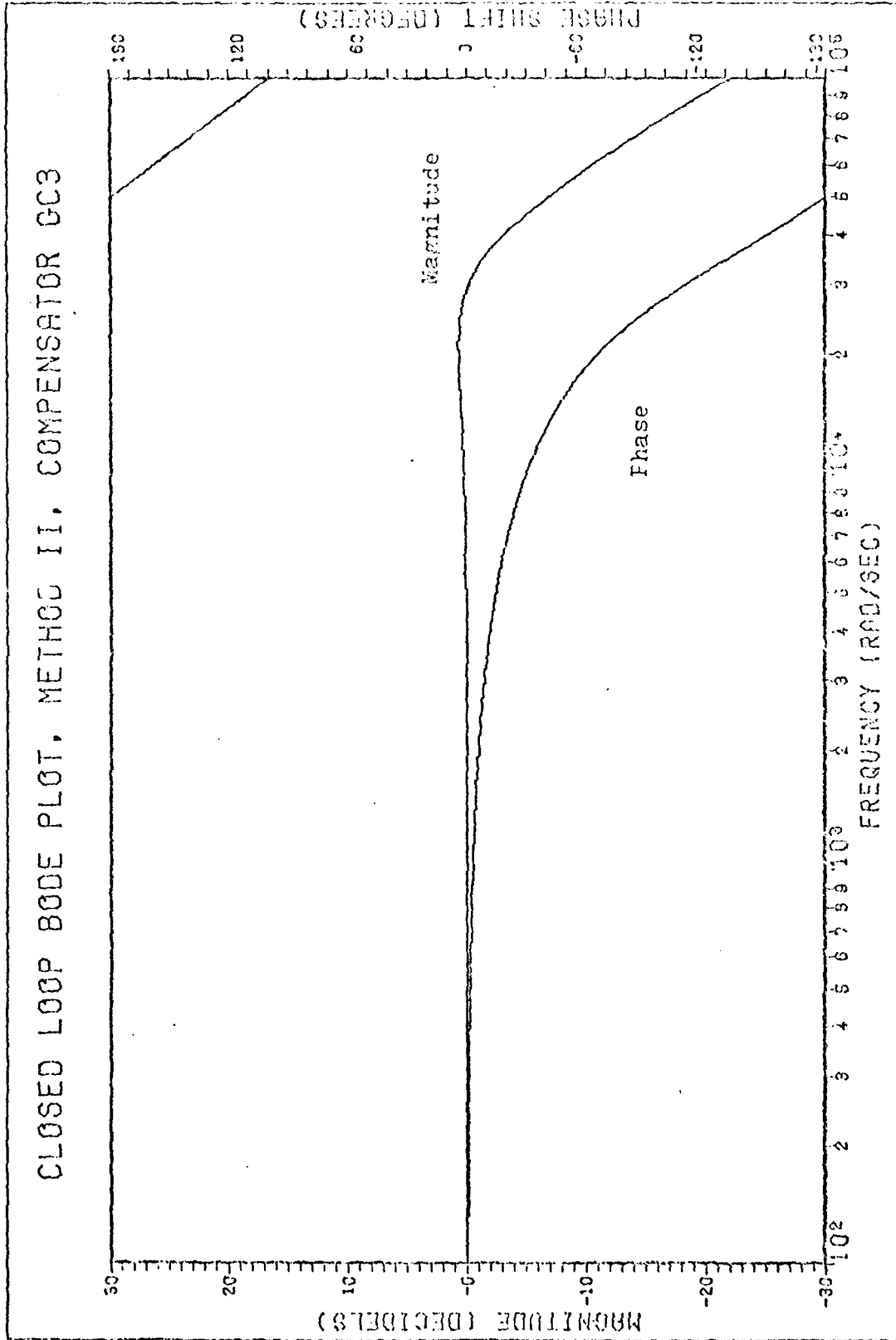

Figure 6.11 Closed Loop frequency Response. Control Method II Using Compensator CC3

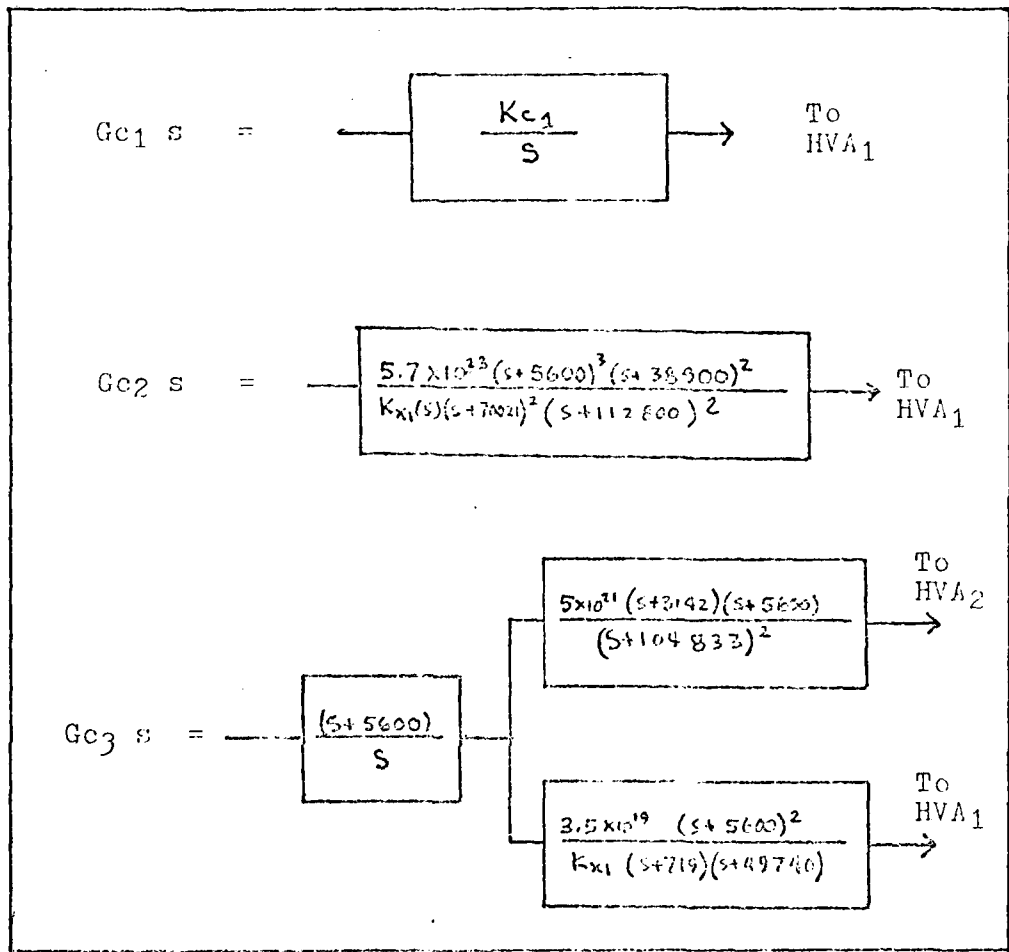
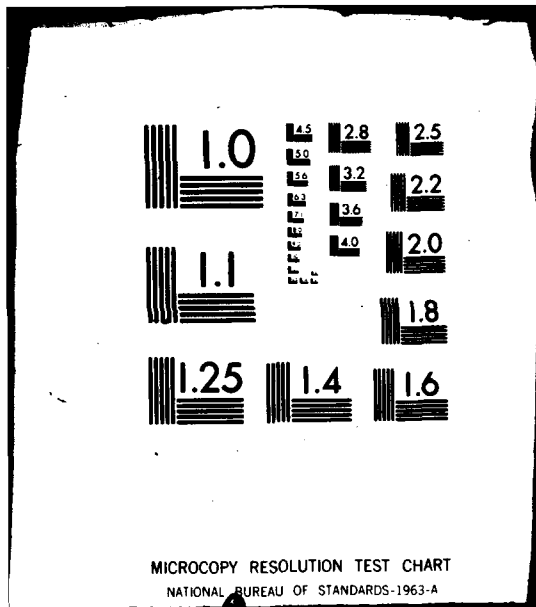

Figure 6.12 Final Compensator Designs





MICROCOPY RESOLUTION TEST CHART  
NATIONAL BUREAU OF STANDARDS-1963-A

## VII Performance Comparisons

### General Discussion

System performance data is contained in this chapter for control methods I and II that can be used to frequency stabilize a laser. A comparison is made between each method's controllable range of the laser cavity. A second comparison is then made between each control method's frequency spectrum of the system error signal. The control range comparisons are made in the next section.

### Control Range Comparison

In order to estimate the difference in the long term control range between control methods I and II, a recording was made over a three minute time span of the correction voltages from HVA<sub>1</sub> and HVA<sub>2</sub>. The experiment was performed while the room temperature was increasing so that a correction voltage drift could be observed. The entire experiment, using both control methods, only took ten minutes to perform and the room temperature drift was assumed to be constant over that short a period. For both control methods, a laser mode was positioned at the top of the laser output intensity curve using HVA<sub>1</sub>. The interferometer resonance was then adjusted to match the laser mode frequency and the loop was closed.

Figure 7.1 shows the results obtained using the

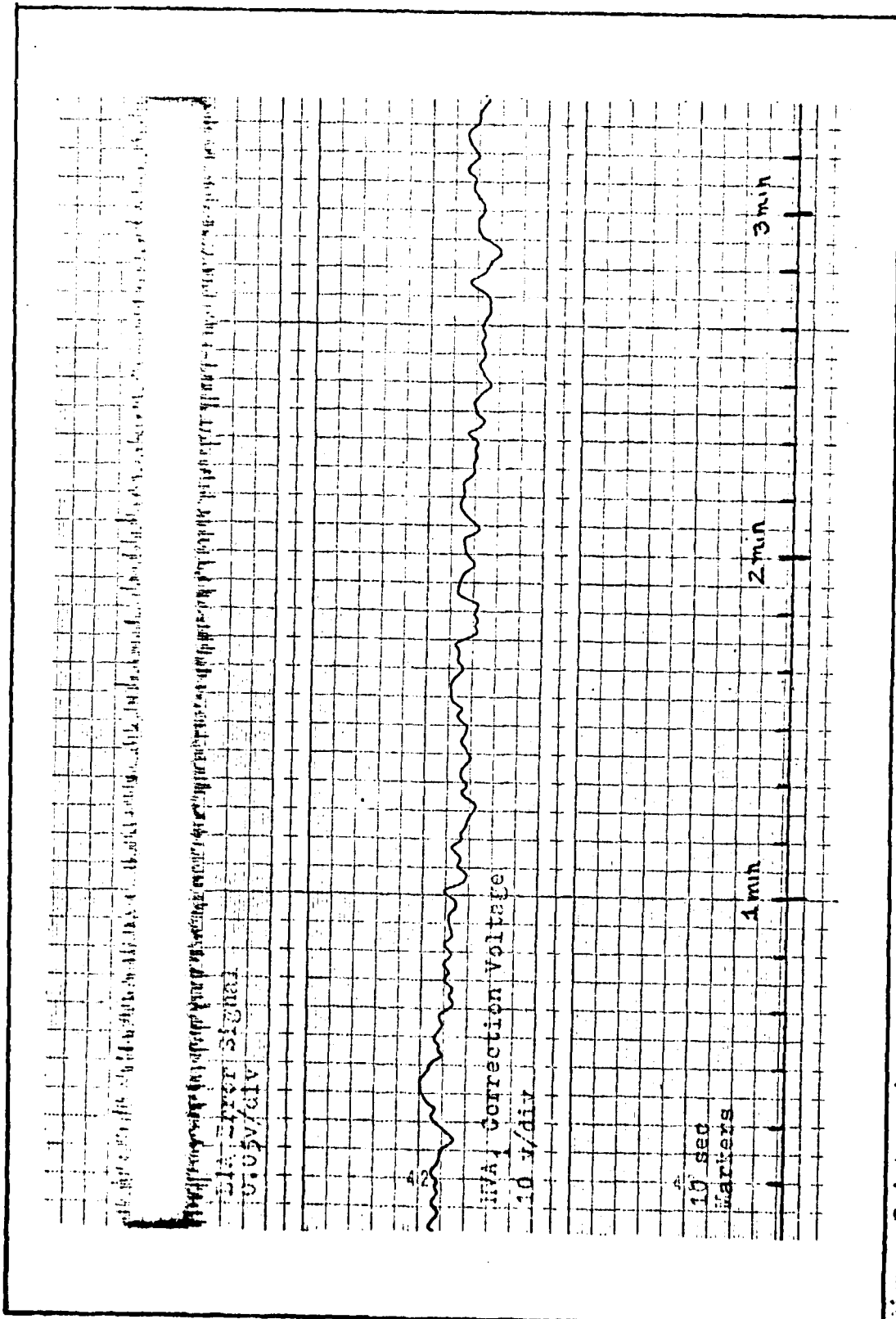

Figure 7.1 Dynamic Range. Method 1, Variation 1, Using Compensator Uc2

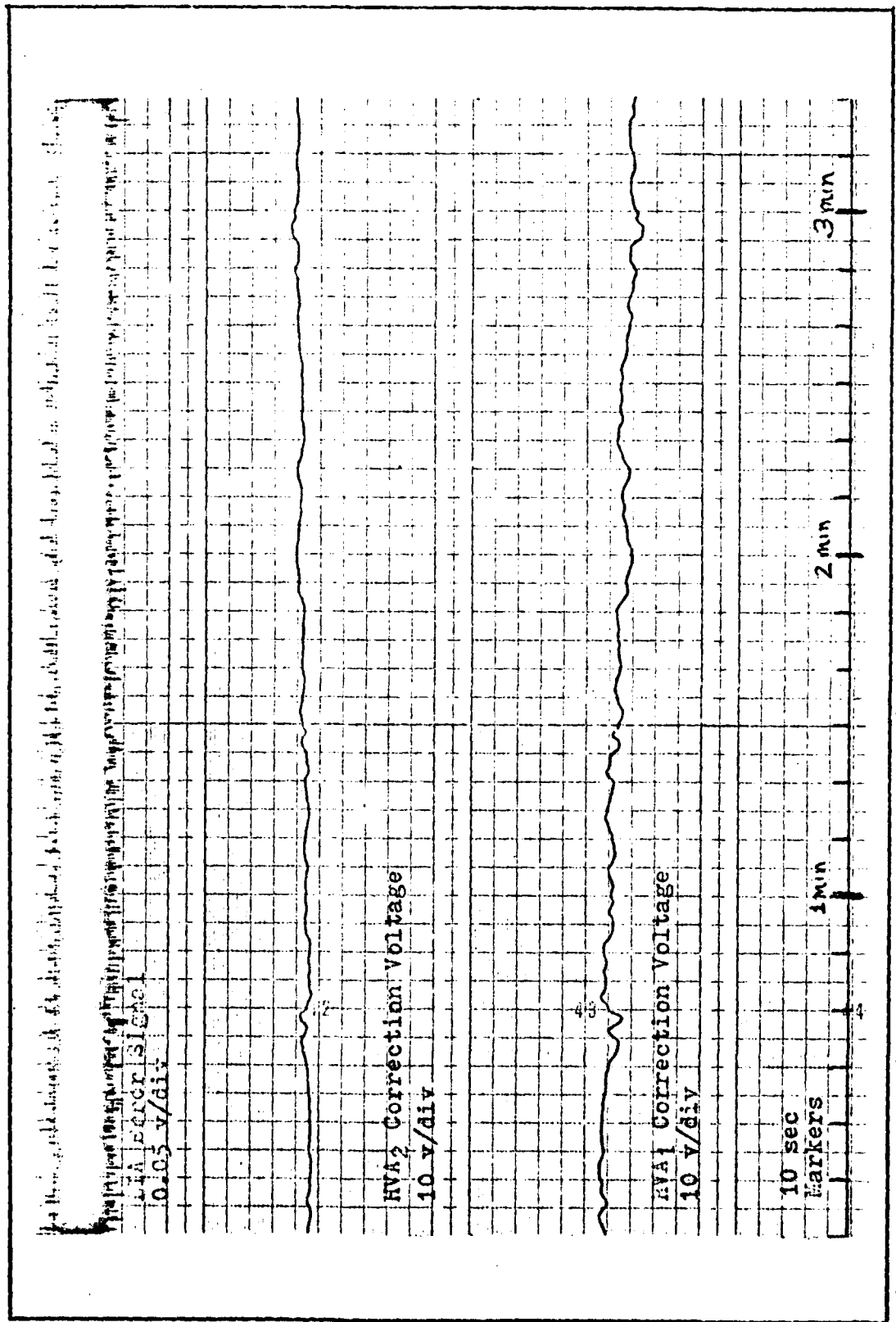

Figure 7.2 Dynamic Range. Method 11, Using Compensator 103

second variation of control method I. The LIA error signal and ten second time markers are also shown in the figure. For the period shown, the HVA<sub>1</sub> correction voltage slowly drops. The maximum voltage shown occurs around 27 seconds with a minimum occurring just before 3 minutes. The difference between the maximum and minimum voltage is 150 volts.

Figure 7.2 shows the results of the same experiment using control method II. Figure 7.2 again shows a slow decrease in the correction voltage from HVA<sub>1</sub>, however, the drift is not as great. This is because the control is split between each PZT as seen by the slowly increasing voltage from HVA<sub>2</sub>. The voltages are of opposite sign because of the negative sensitivity of PZT<sub>2</sub> as shown in Chapter V. The maximum correction voltage from HVA<sub>1</sub> occurs at about ten seconds with the minimum occurring just before three minutes. The difference between maximum and minimum voltage is 90 volts. The difference in HVA<sub>2</sub> maximum and minimum voltage is about 50 volts.

From the results, it is evident that for a large temperature drift saturation will occur a lot sooner for control method I than it will for control method II. From this it is evident that the dynamic range of the control system has been increased by using dual PZT controllers.

The reason for making PZT<sub>2</sub> short is to provide a

fast response time to control high frequency noises. Theoretically, this will allow  $PZT_1$  to be lengthened to further increase the dynamic range of the control loop. The next section compares the frequency spectrum of the error signal,  $e(t)$ , between control methods I and II.

#### Frequency Spectrum of the LIA Error Signal

Performance results were obtained for each control method by recording the noise spectrum of the error signal,  $e(t)$ , from the LIA. Figures 7.3 - 7.12 show the results of the performance tests and are grouped at the back of this section for ease of comparison.

Figures 7.3 through 7.4 show the frequency spectrum of the open loop error signal and are used for comparisons of the noise reduction when the loop is closed. What appears to be noise on the left side of Figures 7.3 through 7.4 is actually trace blur. This was due to the high sweep rate required because the laser frequency would not stay matched very long to the interferometer resonance in the open loop configuration.

Figures 7.5 through 7.8 when compared to Figure 7.3 show the amount of noise reduction achieved when the loop is closed. Noise reduction for each control method is tabulated in Table 7.1. Fourteen db has been added to the noise reduction figures of Table 7.1 because for Figures 7.5 through 7.12 the LIA sensitivity setting was increased

Table 7.1  
Noise Reduction for Each Control Method  
(0-250 Hz Range)

Method	Compensator	Noise Level	Noise Reduction in db
—	open loop	greater than 7v	—
I	Gc <sub>1</sub>	greater than 0.8v	less than -32.8 db
I	Gc <sub>2</sub>	0.4v	-38.9 db
II	Gc <sub>3</sub>	0.2v	-44.9 db

from 500  $\mu$ v to 100  $\mu$ v. This results in a 14 db increase in the magnitude of the error signal.

From Table 7.1 it is evident that for the low frequency range (0Hz - 250 Hz) control method II provides a greater noise reduction than does control method I. Also note that variation 2, using compensator Gc<sub>2</sub>, is much better than variation 1 using compensator Gc<sub>1</sub>.

In order to make an objective comparison of the two control methods, the frequency range of the spectrum analyzer was increased from 50 Hz/cm to 200 Hz/cm as seen in Figures 7.9 to 7.12. By comparing this set of figures, showing the expanded frequency spectrum, method II is seen to provide the best overall noise reduction.

To compare the high frequency noise reduction achieved

by each control method, Figure 7.4 must first be perused. From Figure 7.4, the noise content of the error signal is seen to be below 1000 Hz. Figure 7.9 shows that variation 1 of control method I is effective to about 400 Hz. Figure 7.10 indicates that variation 2 reduces the higher frequency noise as designed. As seen in Figure 7.12, method II also reduces the noise for the higher frequencies and is even more effective.

Figure 7.11 is a picture of the results obtained when only the  $PZT_1$  portion of the control loop is closed using control method II. This simulates the use of a very long PZT for variation 2 of control method I. As seen in Figure 7.12, when the  $PZT_2$  portion of the loop is closed reduction of the higher frequency noises is significant. Conclusions formed from these test results are discussed in the following chapter.

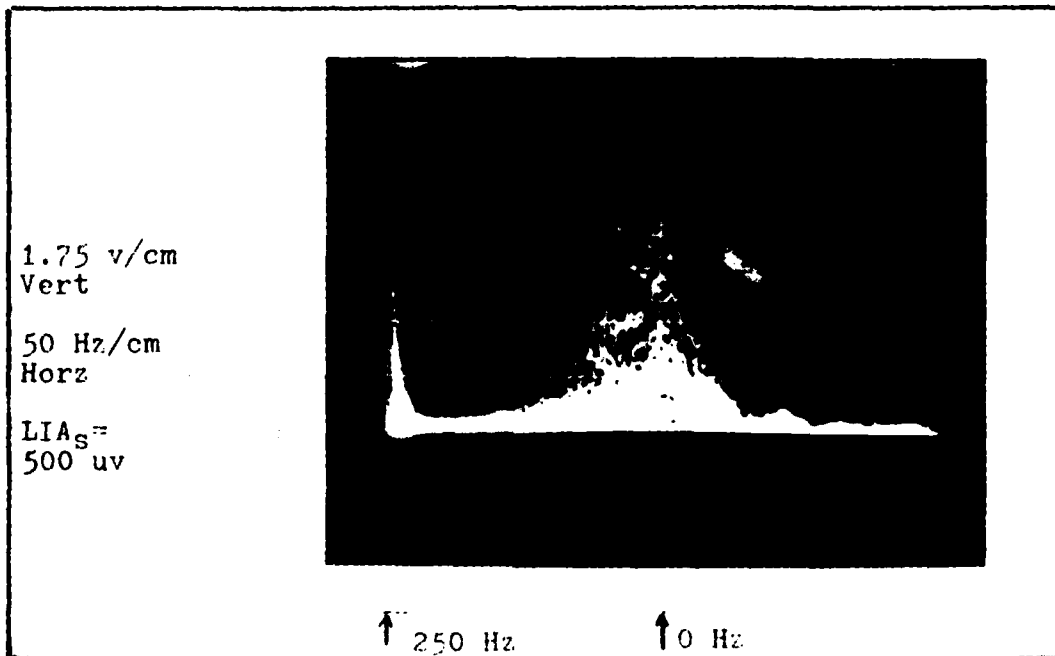

Figure 7.3 Spectral Content of the Open Loop Error Signal  
(0 Hz - 250 Hz)

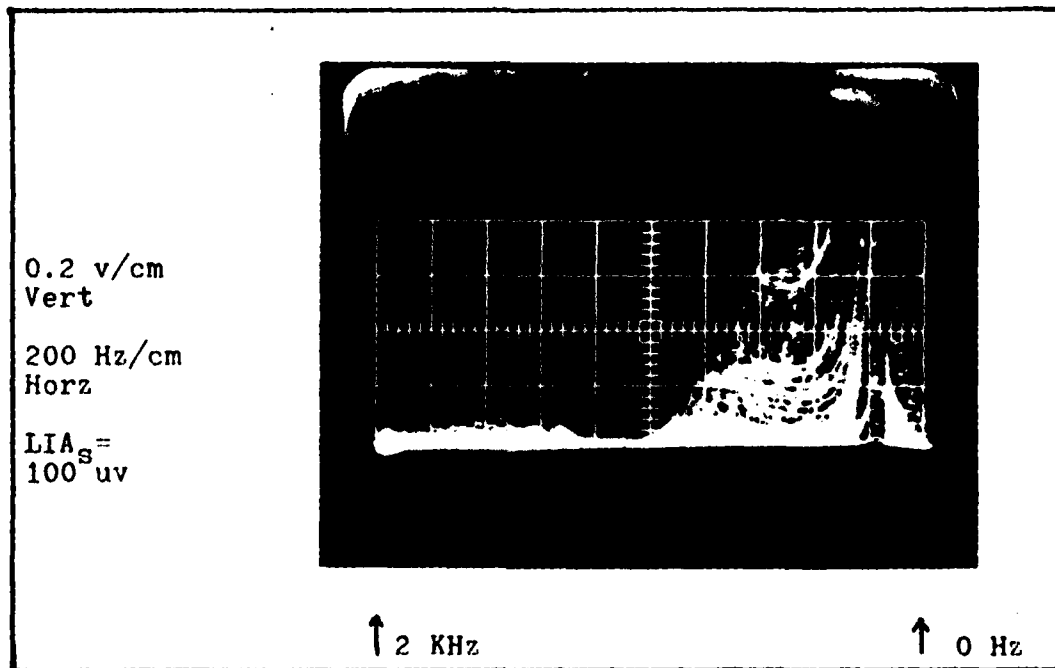

Figure 7.4 Spectral Content of the Open Loop Error Signal  
(0 Hz - 2 kHz)

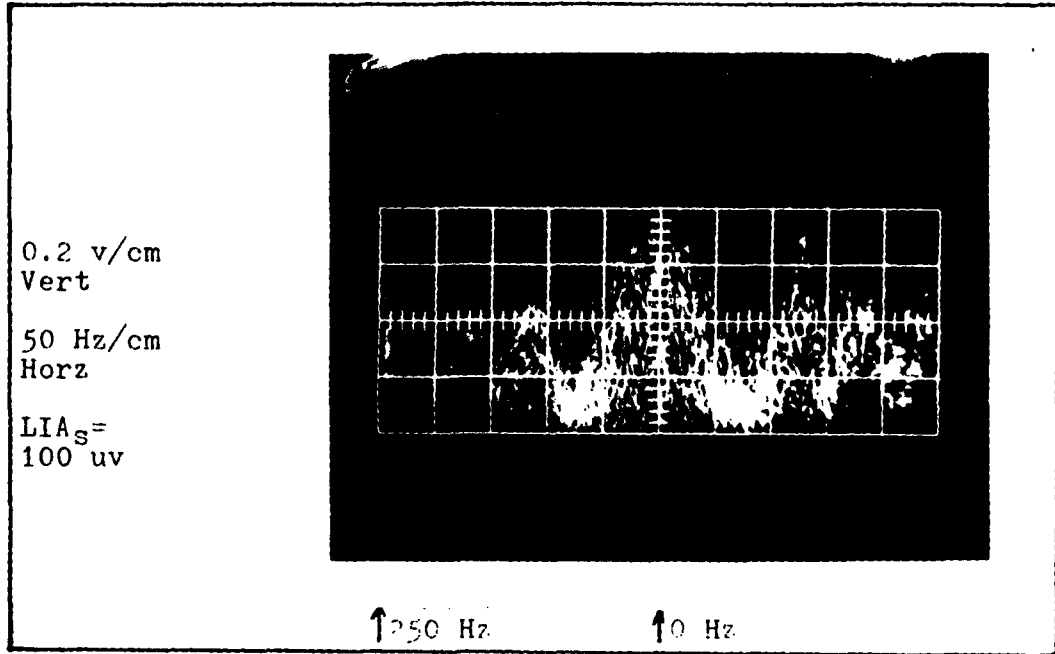

Figure 7.5 Spectral Content of the Closed Loop Error Signal. (0 Hz - 250 Hz) Method I, Variation 1

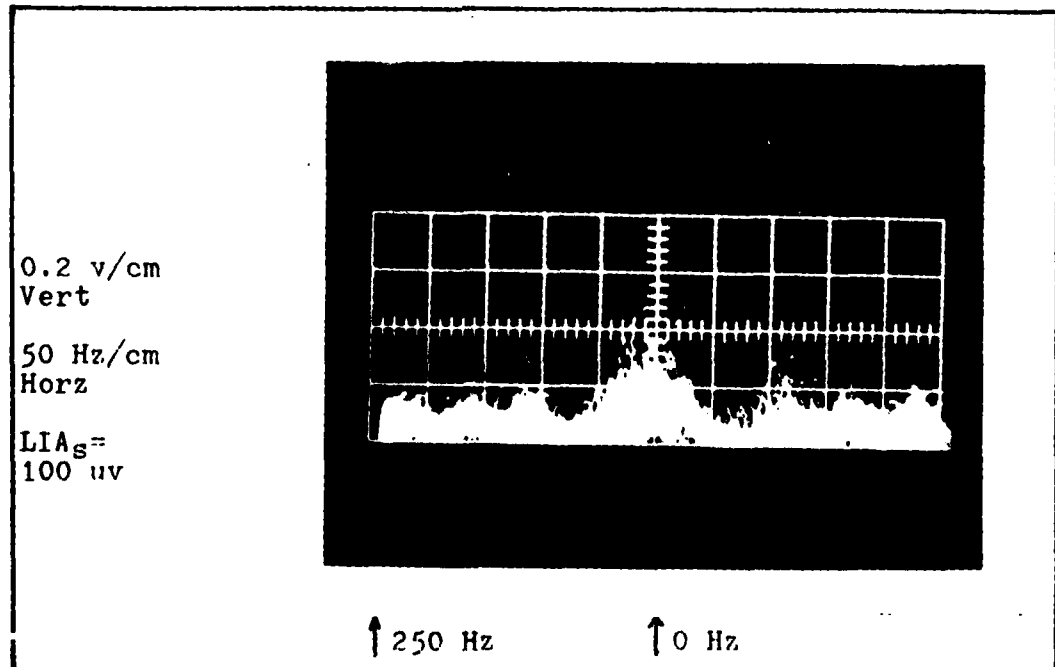

Figure 7.6 Spectral Content of the Closed Loop Error Signal (0 Hz - 250 Hz). Method I, Variation 2, Using Compensator  $G_{c2}$

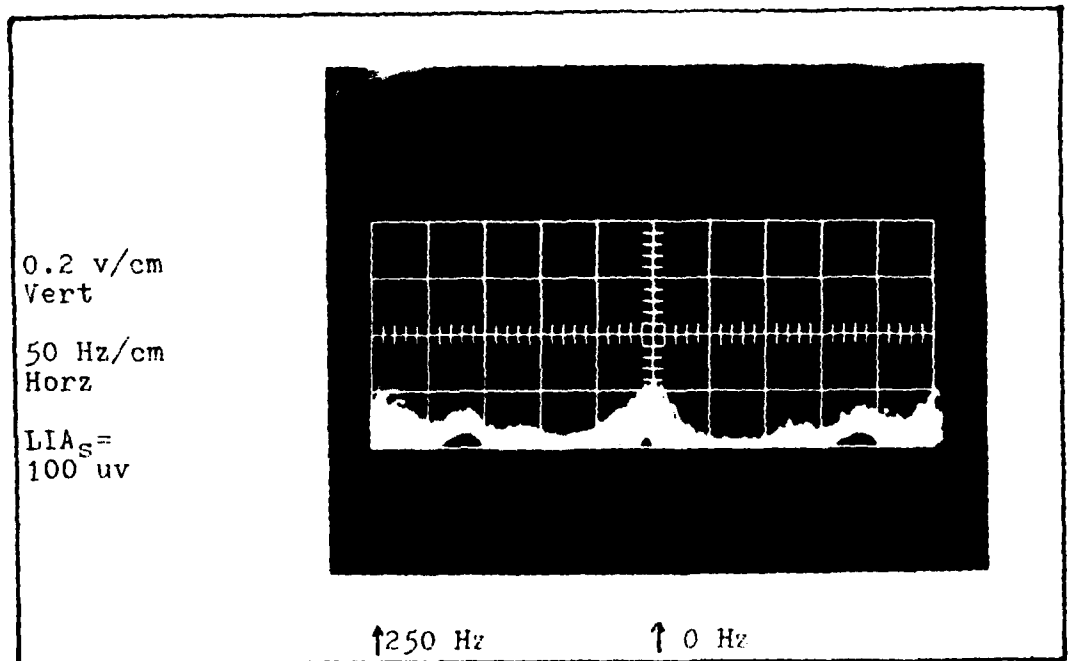

Figure 7.7 Spectral Content of the Closed Loop Error Signal (0 Hz - 250 Hz) Using the  $G_{c3a}$  Portion of Compensator  $G_{c3}$

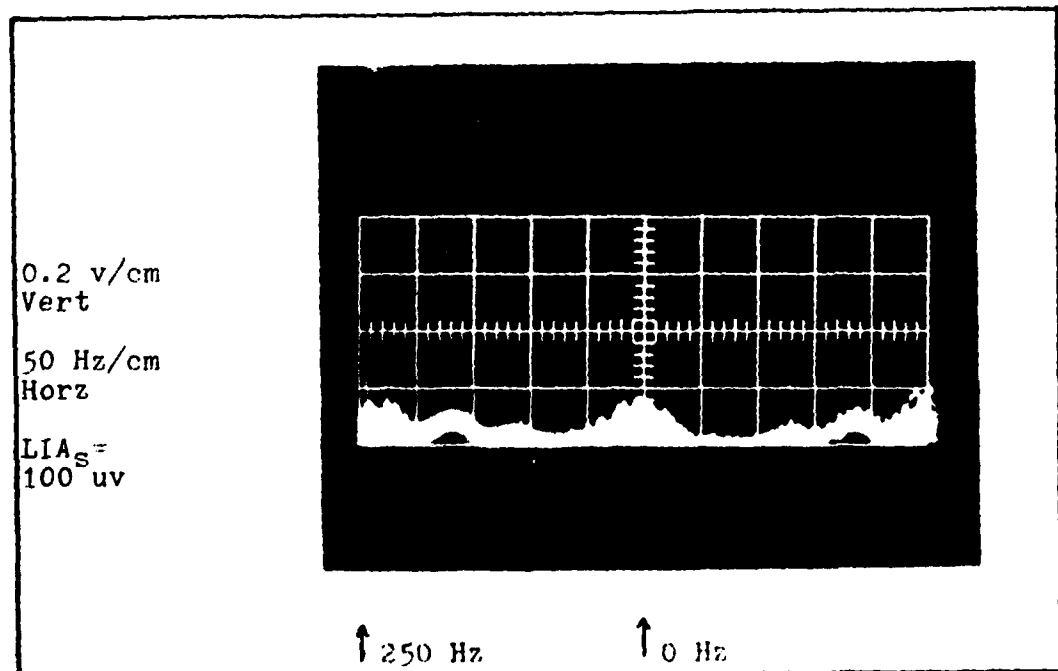

Figure 7.8 Spectral Content of the Closed Loop Error Signal (0 Hz - 250 Hz). Method II



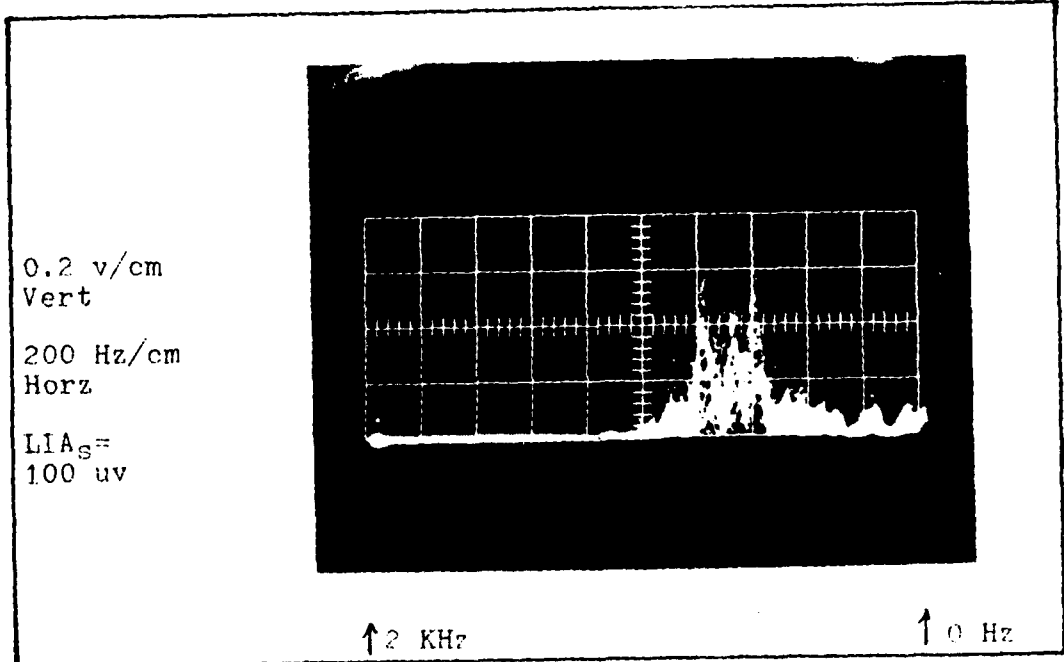

Figure 7.11 Spectral Content of the Closed Loop Error Signal (0 Hz - 2 KHz), Using the  $G_{c3a}$  Portion of Compensator  $G_{c3}$

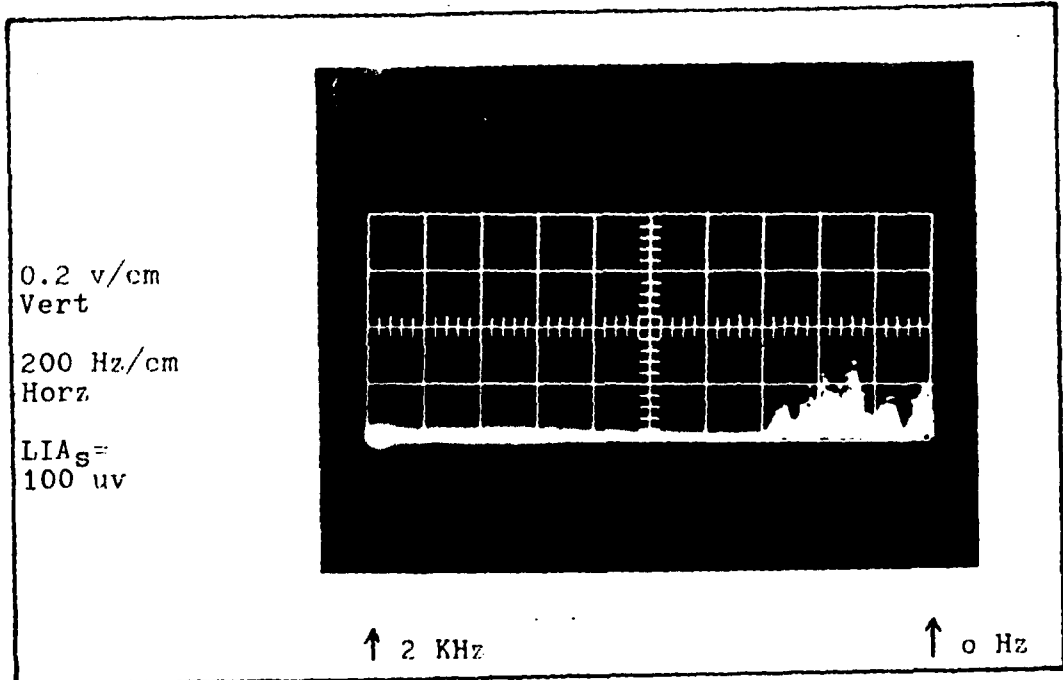

Figure 7.12 Spectral Content of the Closed Loop Error Signal (0 Hz - 2 KHz). Method II

## VIII Conclusions and Recommendations

### General Discussion

The purpose of this research was to compare two methods that can be used to frequency stabilize a laser. Control method I consisted of a feedback loop that used a single PZT controller to correct the laser cavity length. Two variations of method I were used in the research. Variation 1 used a control loop compensator designed from steady state analysis. The compensator used in variation 2 was more sophisticated and was designed from frequency analysis. Control method II deviates from the standard approach used in method I. Two PZTs of different lengths were used to control the laser cavity. A long PZT was used to provide a large dynamic range while a short PZT was used to provide a fast response time.

The results from use of the two control methods were obtained by first recording the difference in the controllable range and second, by recording and comparing the frequency spectrum of the error signal produced by each method.

### Conclusions

From the comparisons made in Chapter VII, control method II is superior to control method I. From the Control Range section of Chapter VII it is clearly evident that the control system limits will be reached much sooner when

control method I is used. This is very important when the system is used in a temperature varying environment. From the Frequency Spectrum section of Chapter VII, it is also evident that the noise reduction for control method II is greater than for control method I. Also, control method II is more effective at high frequencies than control method I.

In conclusion, the use of dual PZT controllers looks very promising and should be adopted where both a large dynamic range and fast response time are desired. Recommendations regarding this research are discussed in the following section.

#### Recommendations

One of the major problems encountered during this research was due to large temperature drifts in the laboratory. As shown earlier, the single PZT controller was only expected to compensate for  $0.3^{\circ}\text{F}$  temperature change before reaching the limit of the high voltage amplifier. Due to the temperature variations in the laboratory, this limit was reached after about 30 minutes using control method II, and even less using control method I. To help solve this problem, a piezoelectric transducer with a much greater sensitivity should be used. It is also recommended that a longer PZT be used that will further increase the dynamic range of the control system. To further reduce the temperature drift problem, the use of super-invar is

recommended for all of the laser hardware along with a much shorter laser.

Large temperature drifts not only cause the laser cavity to change length, but also causes the interferometer cavity length to change. Thus, while the laser frequency may indeed be locked to the interferometer resonance, the actual frequency could be varying with temperature. A solution to this problem is to use a laser gain tube that displays a Lamb dip at the peak of the output intensity curve. The laser frequency could then be locked to the Lamb dip and the interferometer would not be needed in the control loop (Ref 2:351).

## Bibliography

1. Holland, Charles R. and David J. Olkowski. Evaluation of Errors in a Passive Ring Laser Gyroscope. MS Thesis Wright-Patterson AFB, Ohio: Air Force Institute of Technology, December 1978.
2. White, A. D. "Frequency Stabilization of Gas Lasers", IEEE Journal of Quantum Electronics, QE-1, 8:349-357 (November 1965).
3. Smith, P. W. "Stabilized Single-Frequency Output from a Long Laser Cavity", IEEE Journal of Quantum Electronics, QE-1, 8:343-348 (November 1965).
4. O'Shea, Donald C., W. Russel Callen, and William T. Rhodes. Introduction to Lasers and Their Applications. Massachusetts: Addison-Wesley Publishing Company, 1977.
5. Datu, C. A. "Frequency Stabilization by Phase Control of a Single Frequency-Single Mode CO<sub>2</sub> Laser", DDC ADBO 14310L, September 1975.
6. Nagai, Haruhiko. "Laser Frequency Fluctuations Due to Mechanical Vibrations", IEEE Journal of Quantum Electronics, QE-8, 12:857-865 (December 1972).
7. D'Azzo, John J. and Constantine H. Houppis. Linear Control System Analysis and Design: Conventional and Modern. New York: McGraw Hill Inc, 1975.
8. Jodon Engineering Associates Inc. Optical Spectrum Analyzer Model SA 1500 Instruction Manual. Michigan: Jodon Engineering Associates Inc, August 1969.

## Appendix A

### Laser/Interferometer Hardware Designs

The material in Appendix A consists of drawings for the laser and interferometer hardware as referenced in Chapter III. Figures D.1 - D.4 include drawings for the laser end plates, the laser gain tube support blocks, the PZT mounting blocks, and the interferometer mount respectively.

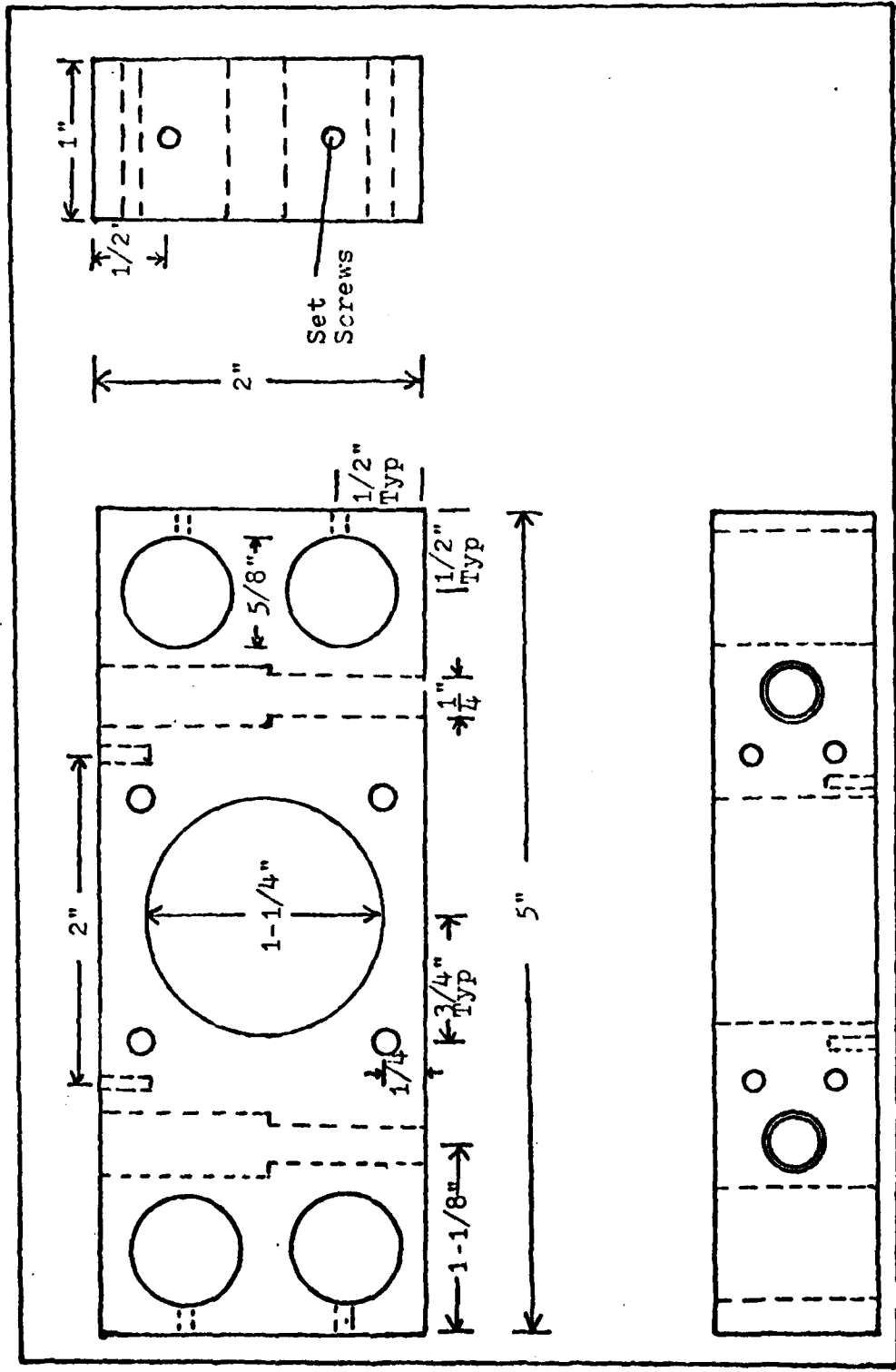

Figure A.1 Laser End Plates

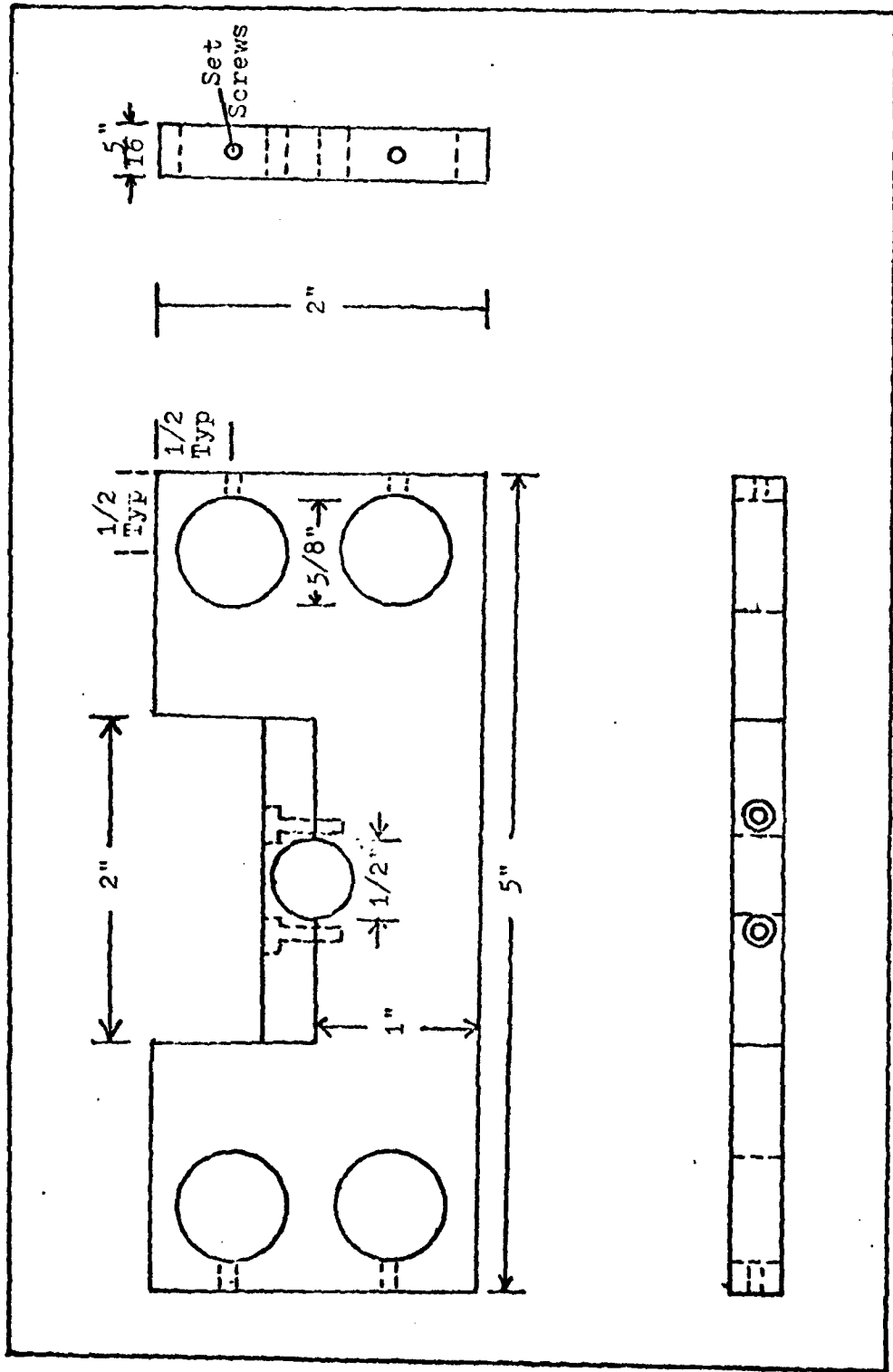

Figure A.2 Laser Gain Tube Support Blocks

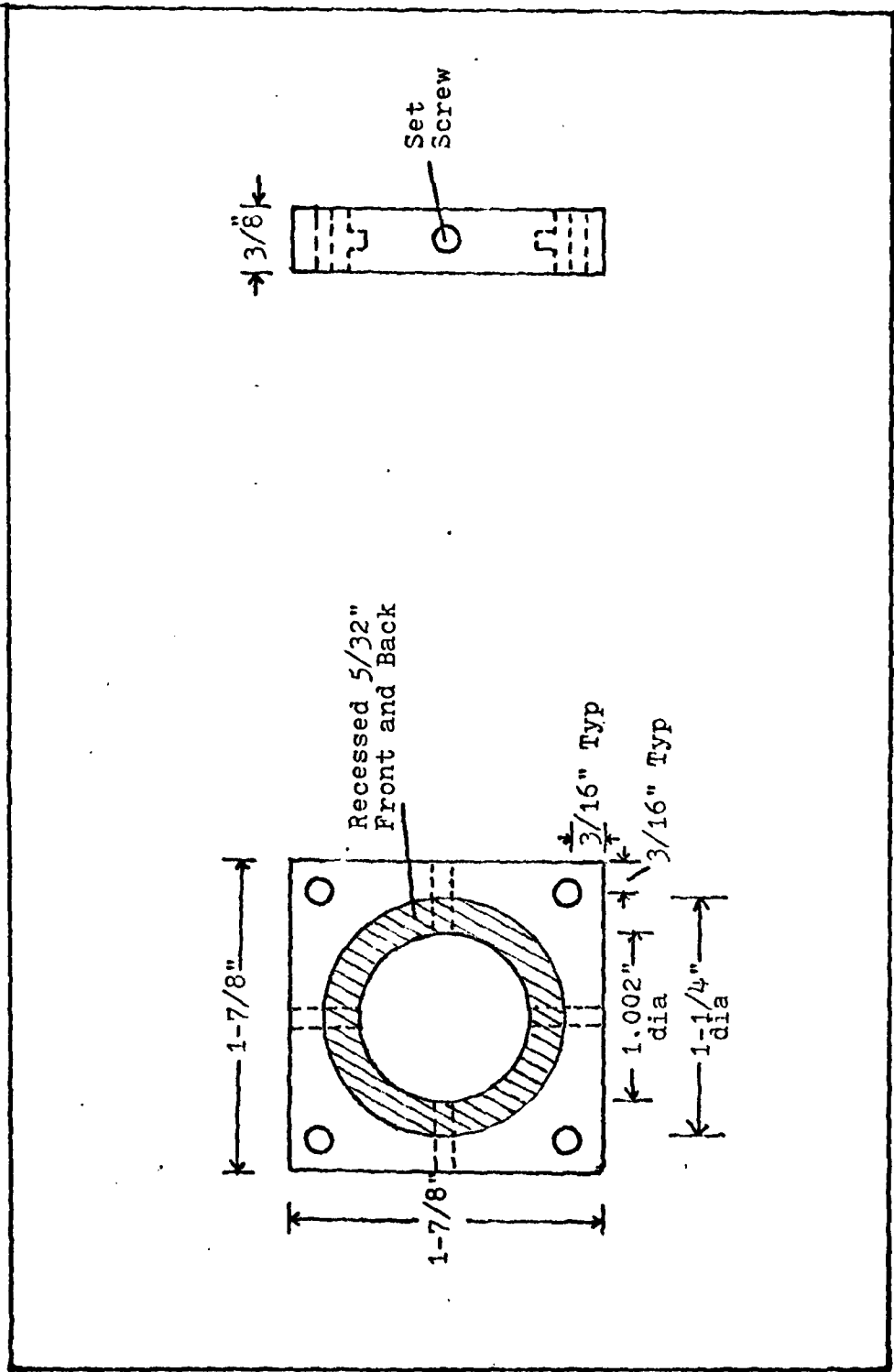

Figure A.3 PZT Mounting Blocks

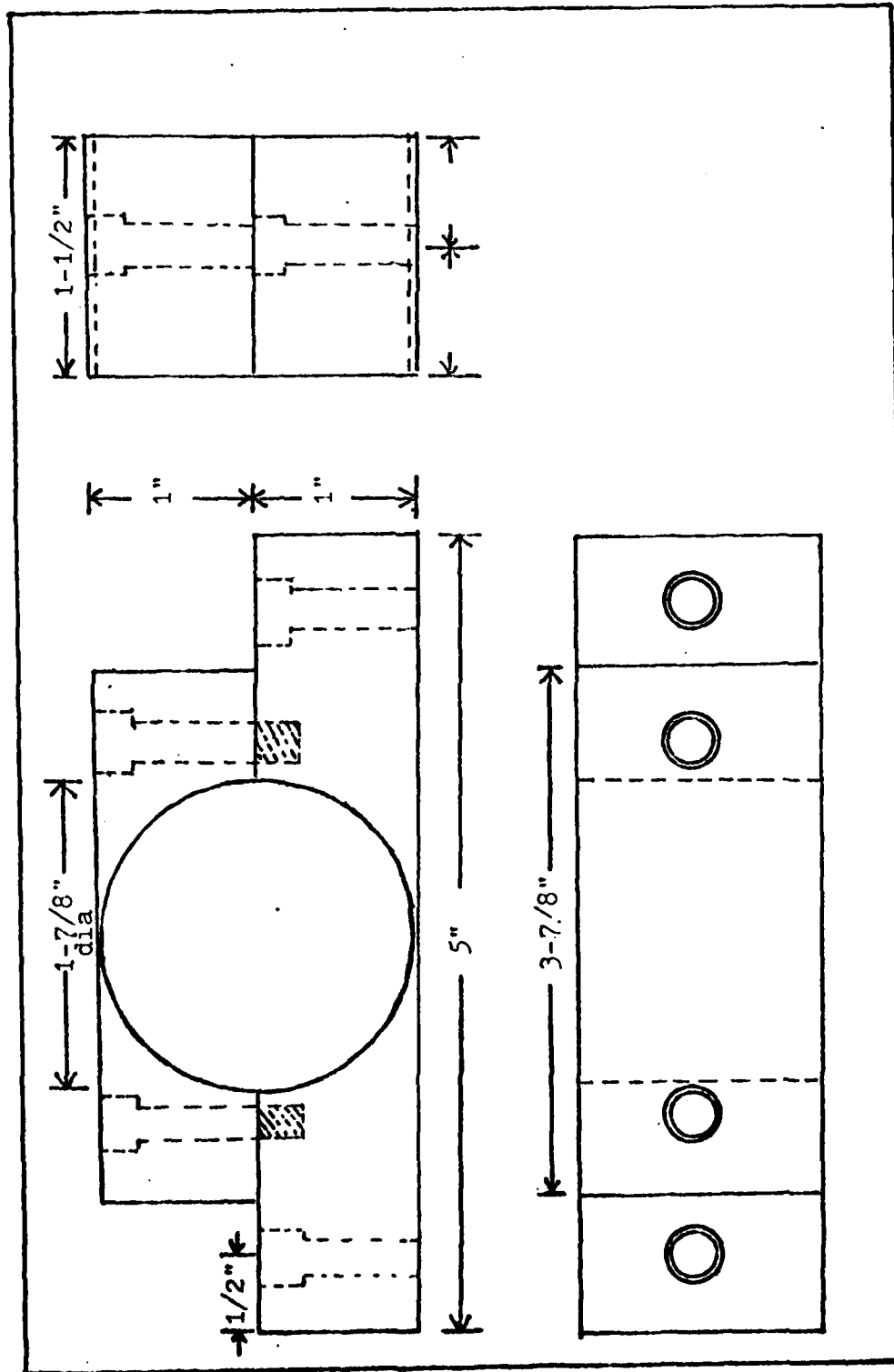

Figure A.4 Interferometer Mount

## Appendix B

### Circuit Design and Tests for Compensator Gc<sub>1</sub>

The material in Appendix B consists of the circuit design procedure, a schematic diagram, and test results for compensator Gc<sub>1</sub> as referenced in Chapter VI.

#### Circuit Design

From Figure 6.12, the compensator Gc<sub>1</sub> is broken into two parts, a gain stage, and an integrator. A summing stage is also included to combine the modulation signal from the LIA, with the compensator signal for input to the HVA. Figure B.5 is a schematic diagram of the compensator and summer. The transfer function for the compensator is

$$\frac{K_{L1}}{S} = \left( \frac{K'}{C_{100} \cdot R_{104}} \right) \left( \frac{1}{S} \right) \quad (B.1)$$

where K' will remain as a variable gain adjustable by R100 and the first stage shown in Figure B.5.

#### Operational Tests

Figure B.2 shows the expected frequency response plot for the compensator. The compensator was tested using the equipment configuration shown in Figure B.1.

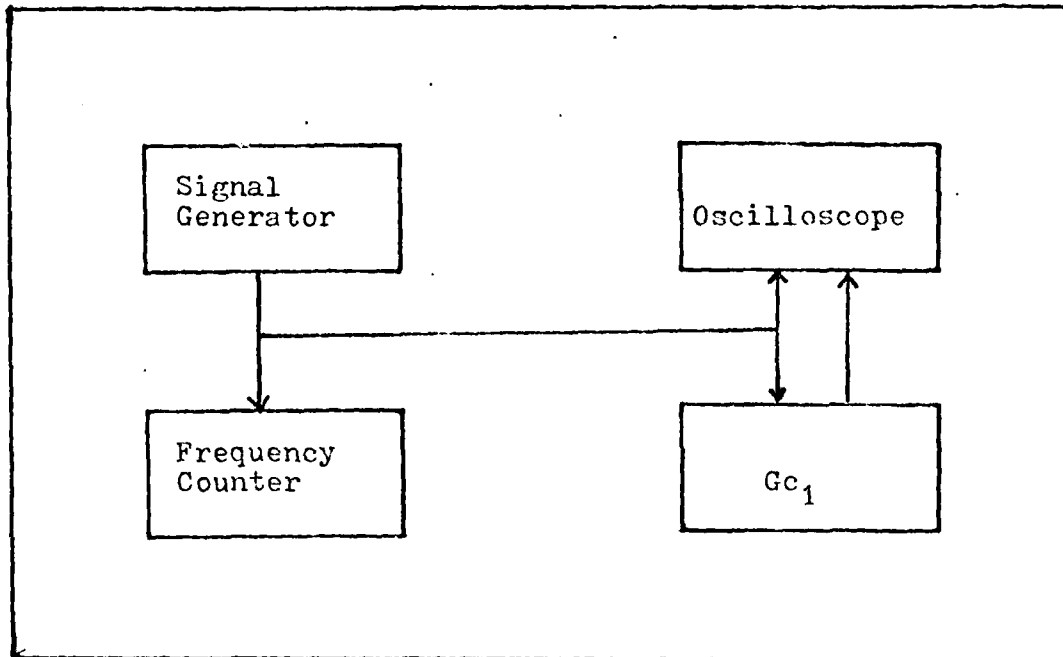

Figure B.1 Block Diagram of Equipment Used to Test Compensator  $G_{c1}$

The frequency from the signal generator was adjusted while the output of  $G_{c1}$  was viewed on the oscilloscope. The phase and amplitude of  $G_{c1}$  was compared to the input signal with results as plotted in Figure B.2. The solid lines in Figure B.2 indicate the expected phase and magnitude of the results while X indicates the measured magnitude and O represents the measured phase.

As shown by the results, the compensator works as designed. Figures B.3 and B.4 show the amplitude and spectral content of the noise from  $G_{c1}$  with the input shorted. As seen in Figure B.3, the noise amplitude is very small and has little affect on the laser for the same reasons as stated in Chapter IV.

# OPEN LOOP BODE PLOT, COMPENSATOR GC1

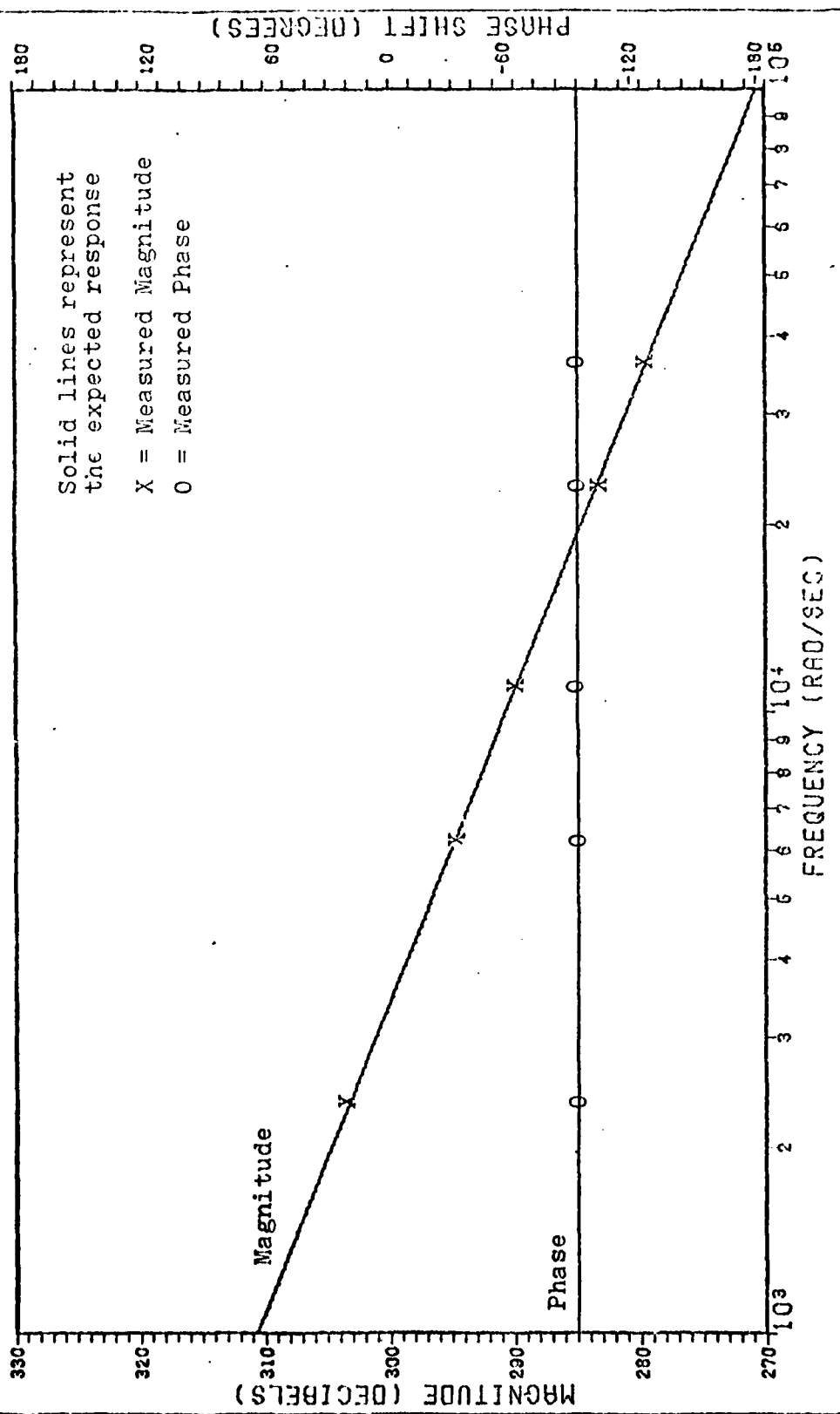

Figure B.2 Measured vs Expected Frequency Response Plot for Compensator GC1

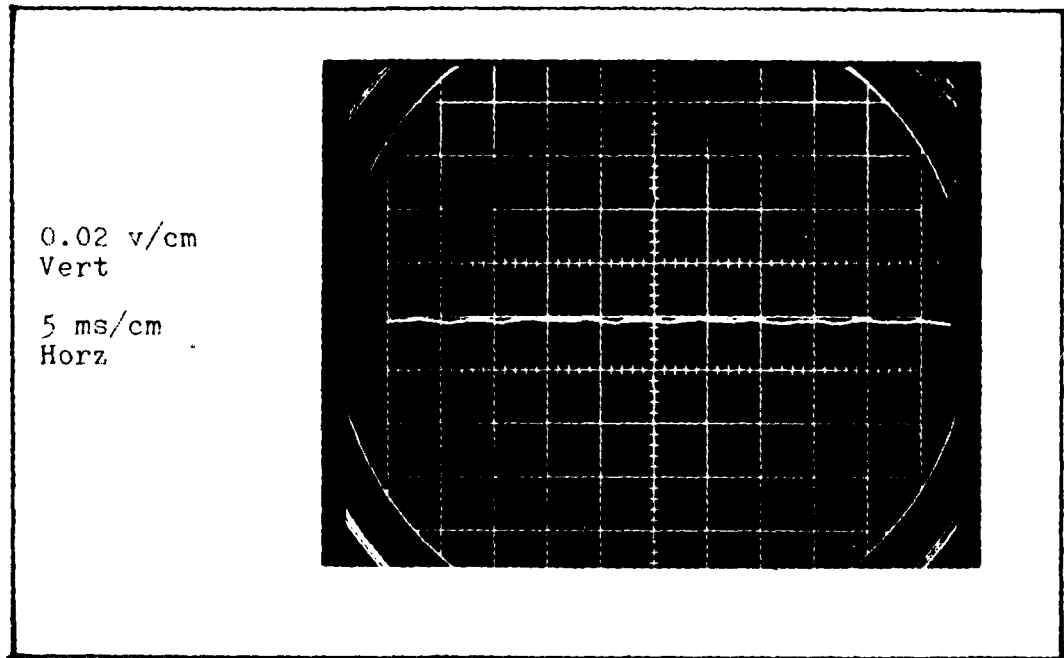

Figure B.3 Noise from Compensator  $G_{c1}$

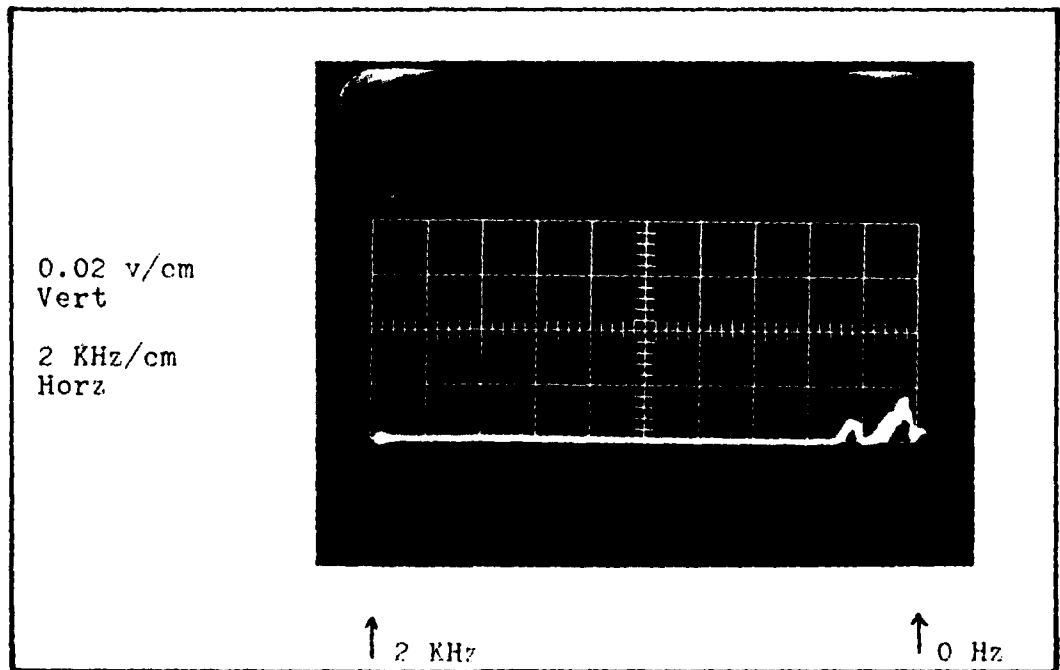
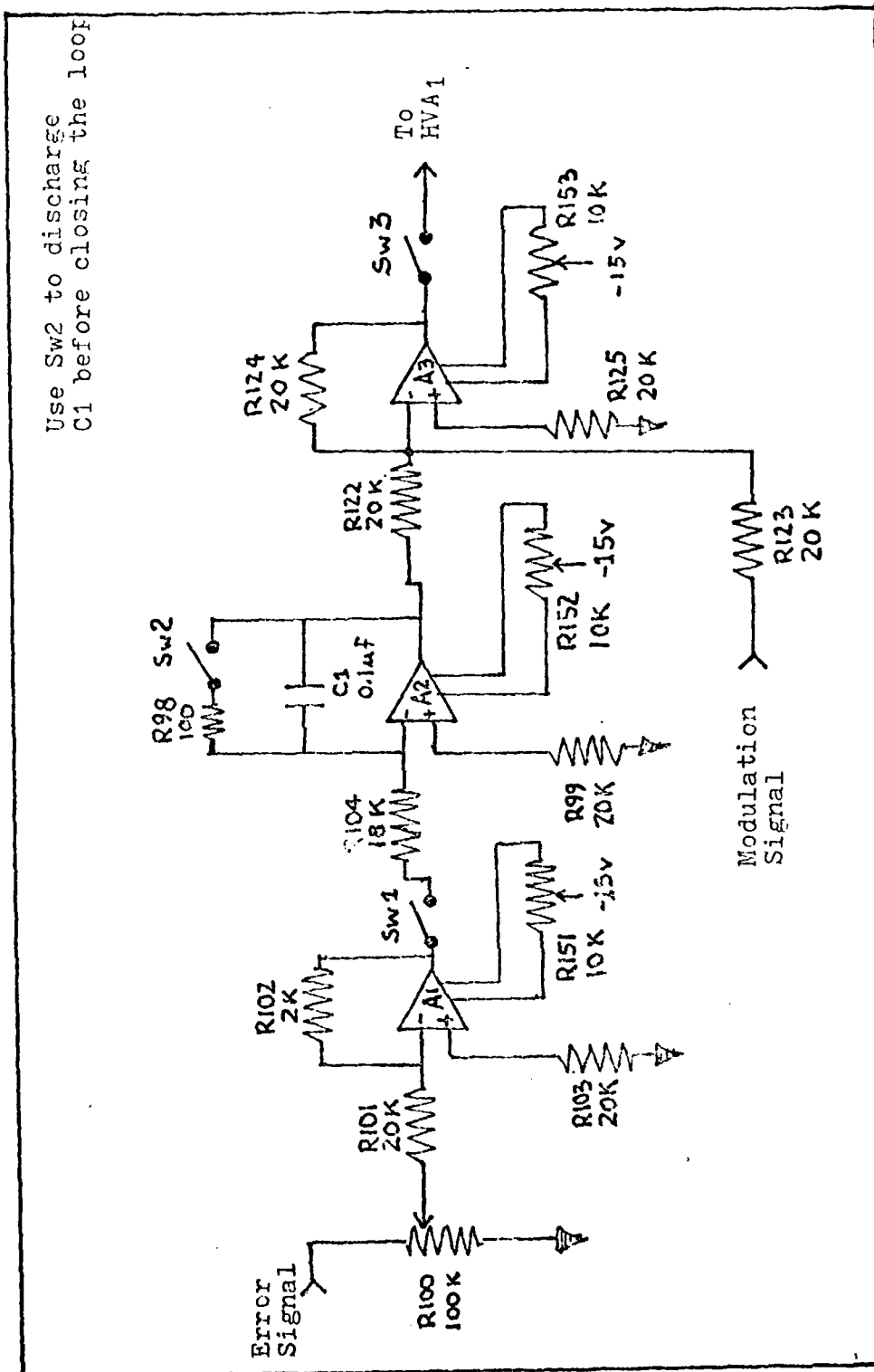

Figure B.4 Spectral Content of Noise from Compensator  $G_{c1}$



Use Sw2 to discharge C1 before closing the loop

Figure B.5 Schematic Diagram of Compensator Gc1 for Variation 1 of Method II

## Appendix C

### Circuit Design and Tests for Compensator Gc<sub>2</sub>

The material in Appendix C consists of the circuit design procedure, a schematic diagram, and operational test results for compensator Gc<sub>2</sub> as referenced in Chapter VI.

#### Circuit Design

The transfer function for Gc<sub>2</sub> from Eq (6.25) is shown again here with a variable gain K'':

$$G_{c2} = \frac{K''(s+5600)^3(s+3890)^2}{(s)(s+7002.1)^2(s+112800)^2} \quad (C.1)$$

Eq (C.1) was broken into six parts and amplifier transfer functions GA<sub>4</sub> to GA<sub>9</sub> were assigned to each part as shown in Figure C.1. The schematic diagram shown in Figure C.5 was determined from Figure C.1. Component values were found by finding the ratio of each stage's output impedance to input impedance and equating the ratio to the respective transfer function.

#### Operational Tests

The same tests that were performed on Gc<sub>1</sub> were also performed on Gc<sub>2</sub> with results plotted in Figure C.2. The

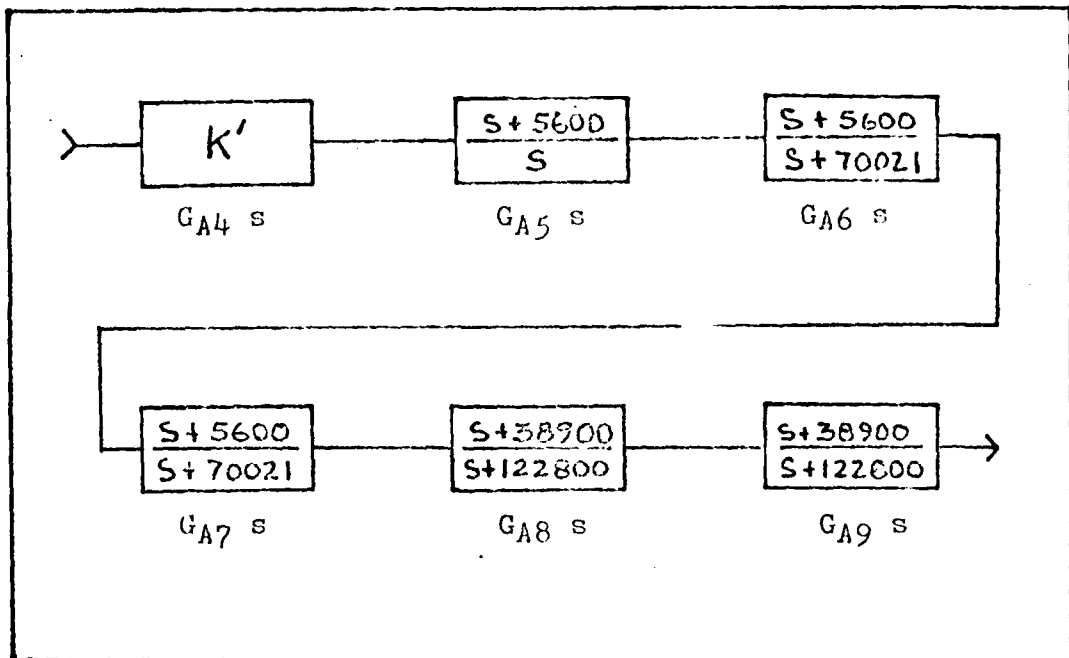

Figure C.1 Amplifier Assignment to Compensator  $G_{c2}$

solid lines in Figure C.2 are the expected phase and magnitude of the test results while X indicates the measured magnitude and O indicates the measured phase.

As shown by the results, the compensator works as designed. Figures C.3 and C.4 show the amplitude and spectral content of the noise from  $G_{c1}$  with the input shorted. The maximum peak-to-peak amplitude shown in Figure C.3 is 0.07 volts and results in a very high signal-to-noise ratio as explained in Chapter IV. Therefore, the noise has very little affect on the laser frequency.

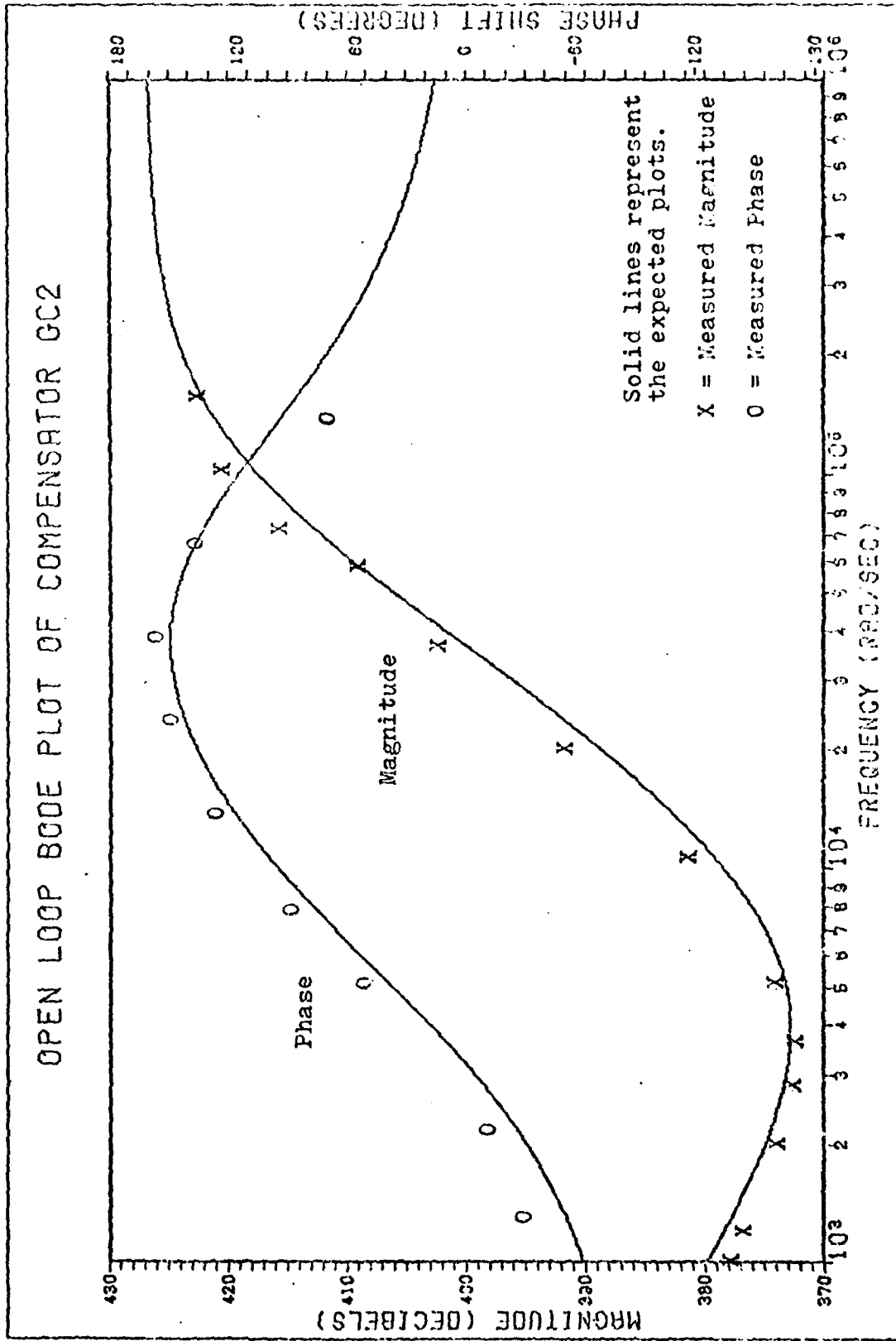

Figure C.2 Measured vs Expected Frequency Response for Compensator Gc2

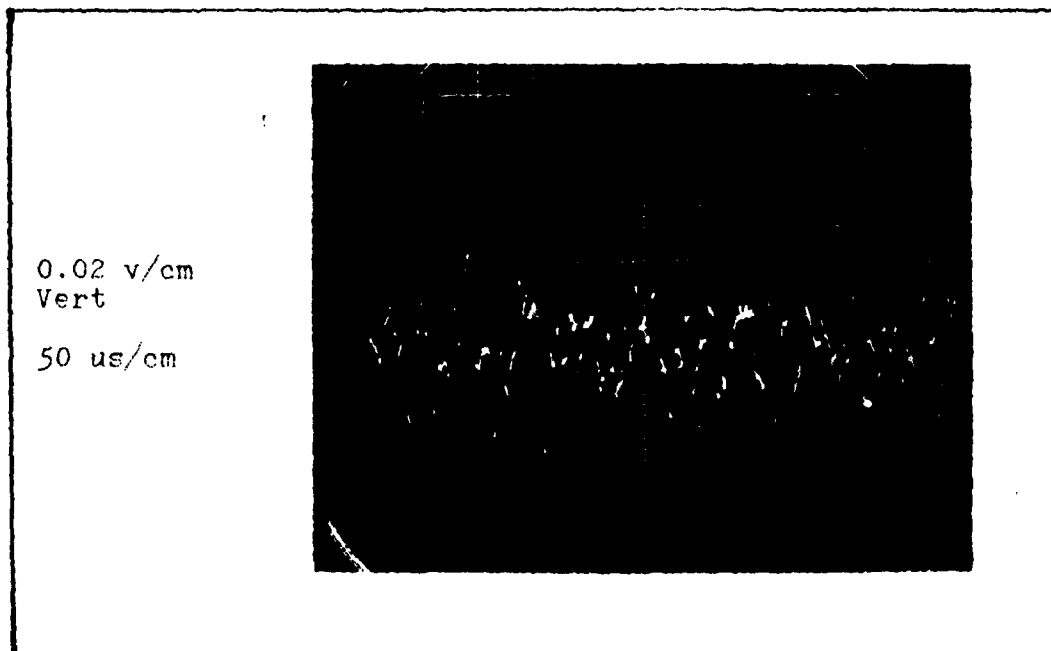

Figure C.3 Noise from Compensator  $G_{c2}$

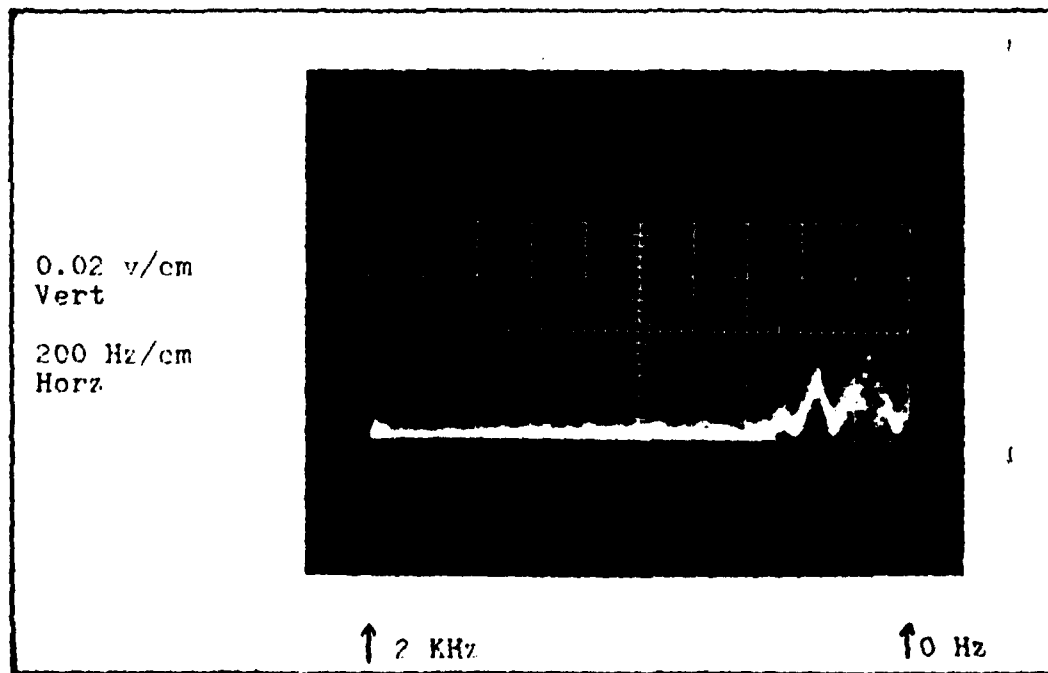

Figure C.4 Spectral Content of Noise from Compensator  $G_{c2}$

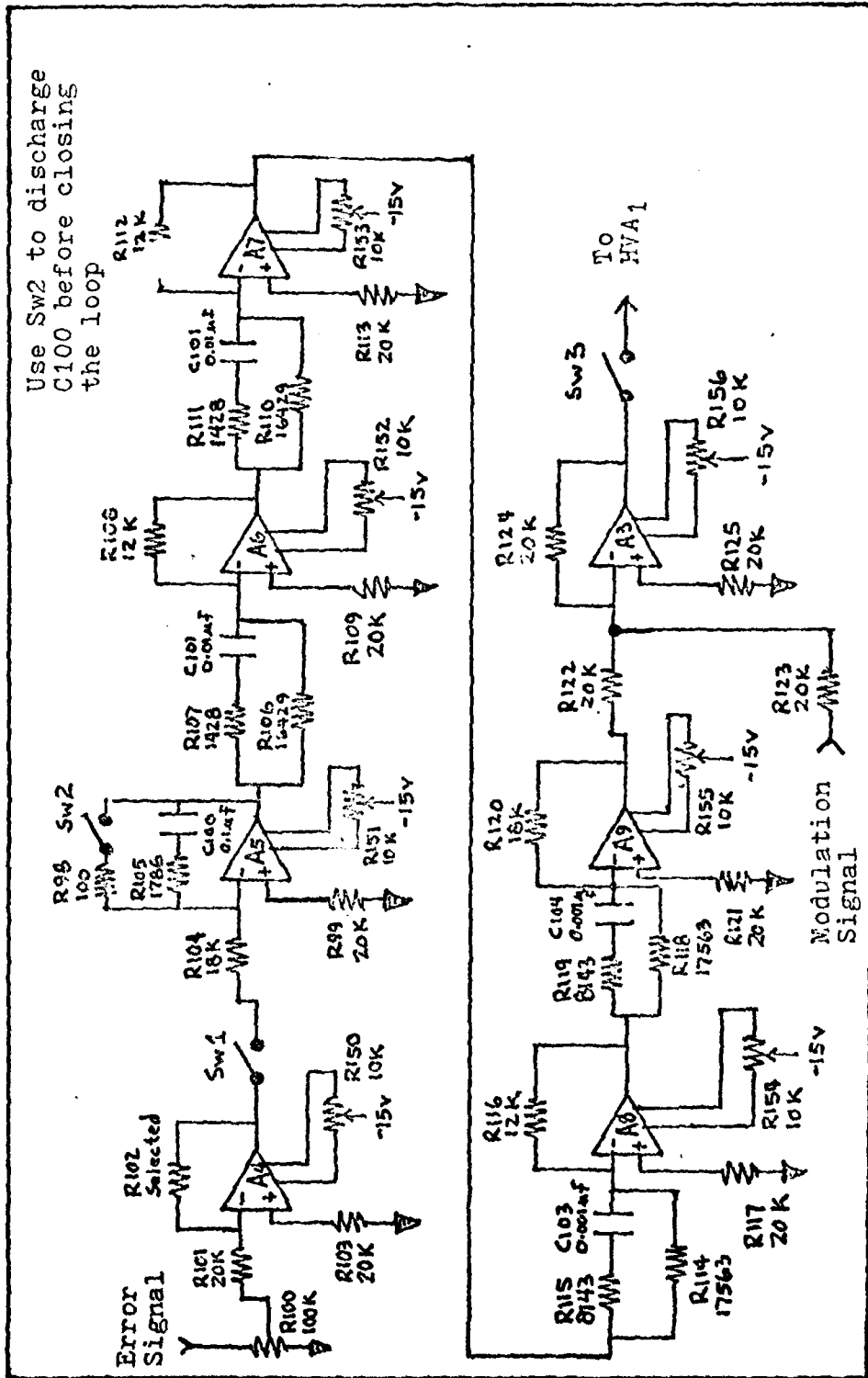

Figure C.5 Schematic Diagram of Gc2, Variation 2 of Method I

## Appendix D

### Circuit Design and Tests for Compensator Gc<sub>3</sub>

The material in Appendix D consists of the circuit design, a schematic diagram, and operational test results for compensator Gc<sub>3</sub> as referenced in Chapter VI.

The transfer function for Gc<sub>3</sub> is divided into two parts, Gc<sub>3a</sub> and Gc<sub>3b</sub> as shown in Chapter VI. The circuit design for both parts will be covered in the next section.

#### Circuit Design of Gc<sub>3a</sub> and Gc<sub>3b</sub>

The transfer functions for Gc<sub>3a</sub> and Gc<sub>3b</sub>, from Figure 6.12, are shown again here with variable gains K'''<sub>a</sub> and K'''<sub>b</sub>

$$G_{c3a} = \frac{K'''_a (s+5600)^3}{(s)(s+719)(s+49740)} \quad (D.1)$$

$$G_{c3b} = \frac{K'''_b (s+3142)(s+5600)}{(s+104833)^2} \quad (D.2)$$

Eqs (D.1) and (D.2) are broken into seven parts and amplifier transfer functions G<sub>A10</sub> through G<sub>A15</sub> are assigned to each part as shown in Figure D.1. The schematic diagram shown in Figure D.8 was determined from Figure D.1. Component values were found by finding the ratio of each stage's output impedance to input impedance and equating the results to the respective transfer function.

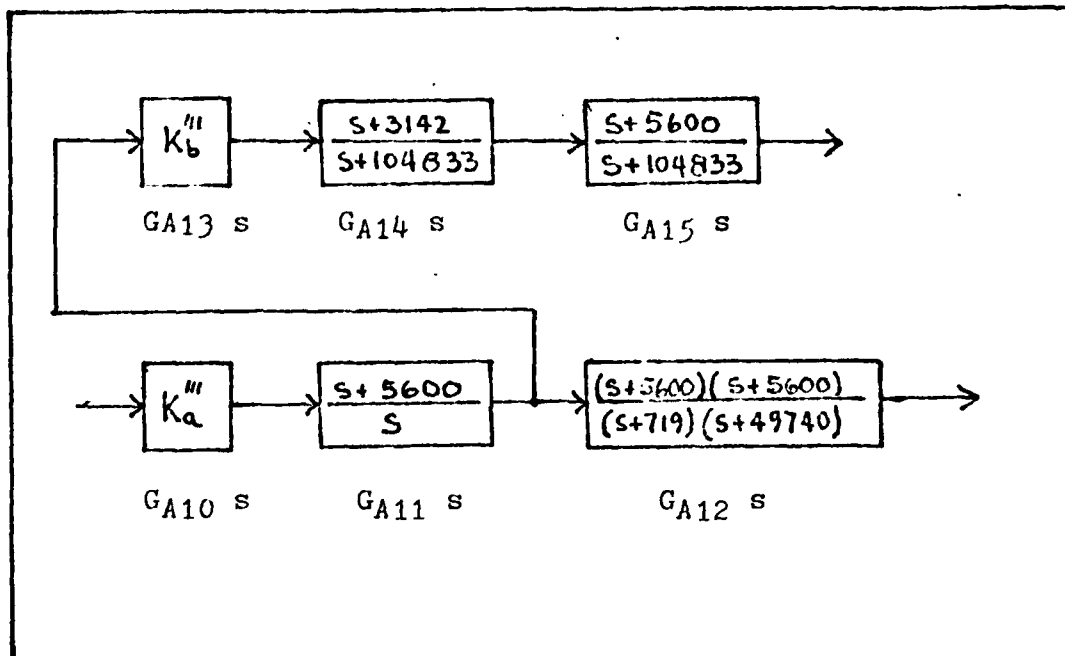

Figure D.1 Amplifier Assignment to Compensator  $G_{c3}$

#### Operational Tests

The same tests that were performed on  $G_{c1}$  in Appendix B, were also performed on both compensator  $G_{c3a}$ , and the upper portion of  $G_{c3}$  shown in Figure D.1. The measured frequency responses of the compensators are plotted in Figures D.2 and D.3. The solid lines represent the expected phase and magnitude while the Xs and Os show the measured magnitude and phase respectively. As shown by the results, the compensator works as designed.

Figures D.4 through D.7 show the amplitude and spectral content of the noise from  $G_{c3a}$  and  $G_{c3b}$  with the input shorted. In both cases, the noise is relatively small and results in a very high signal-to-noise ratio as explained in Chapter IV, therefore, the noise has very little affect on the laser frequency.

# OPEN LOOP BODE PLOT FOR COMPENSATOR GC3a

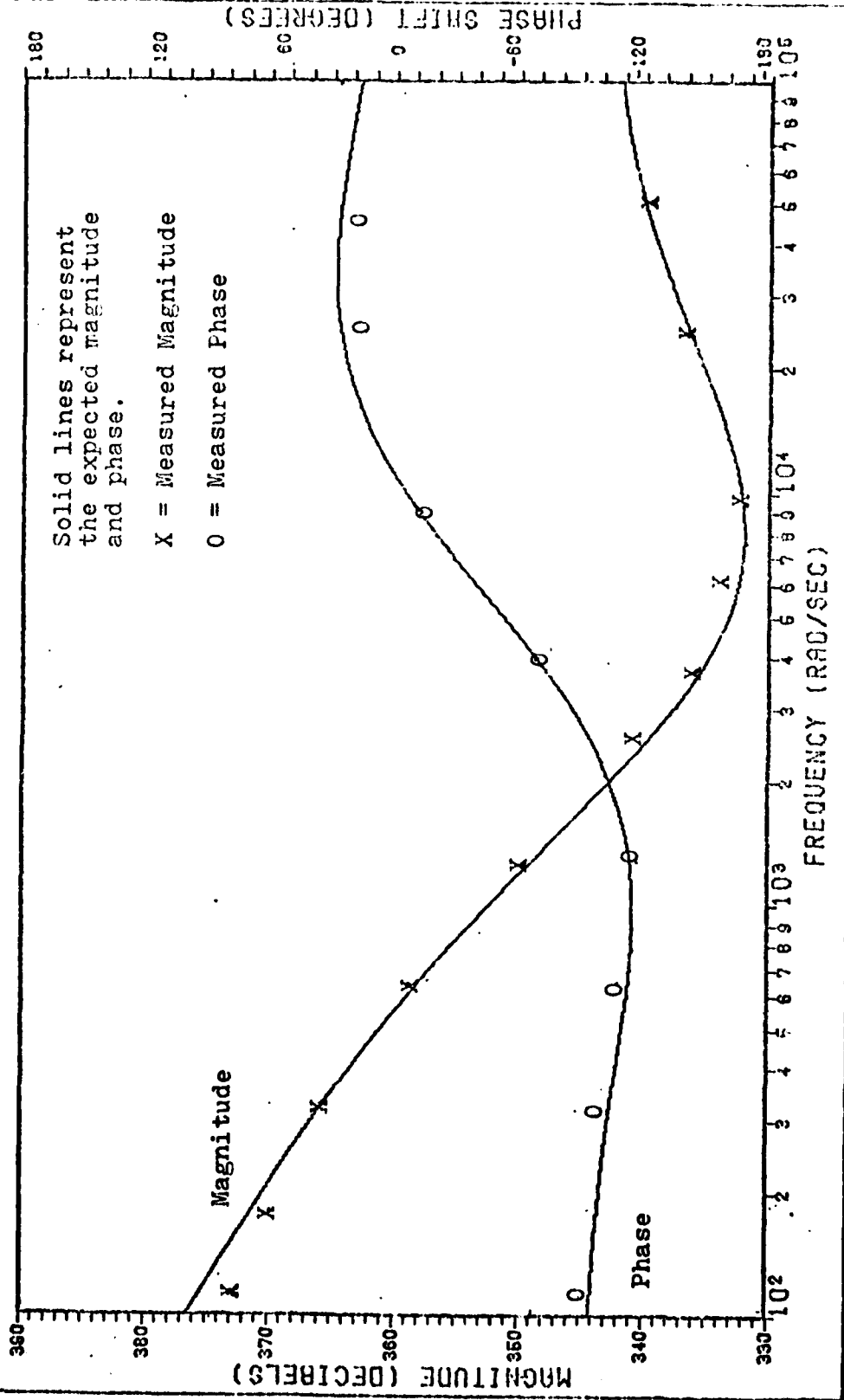

Figure D.2 Measured vs Expected Frequency Response of Compensator Gc3a

# OPEN LOOP BODE PLOT FOR COMPENSATOR GC3b

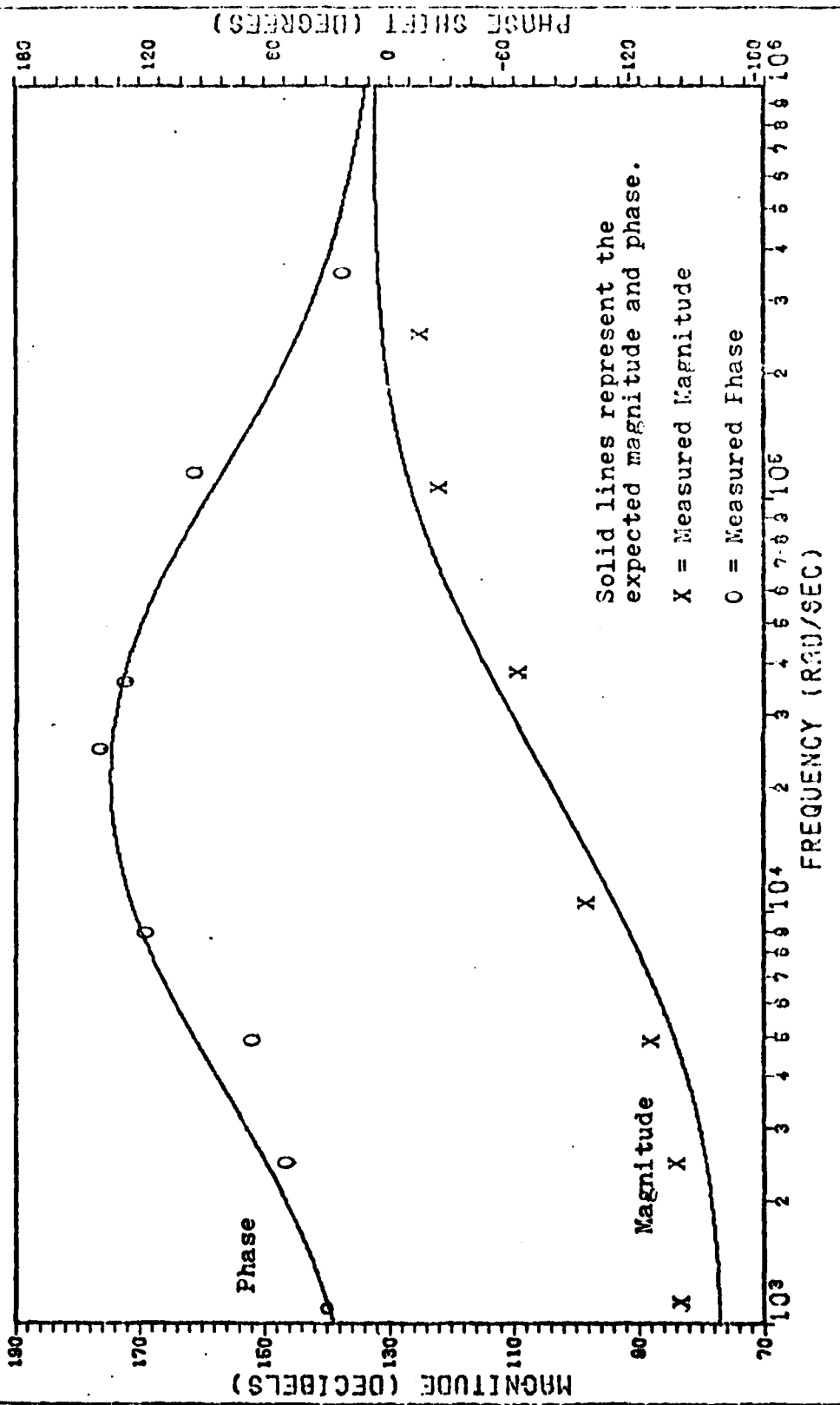

Figure D.3 Measured vs Expected Frequency Response of the Upper Portion of Compensator GC3 as seen in Figure D.1

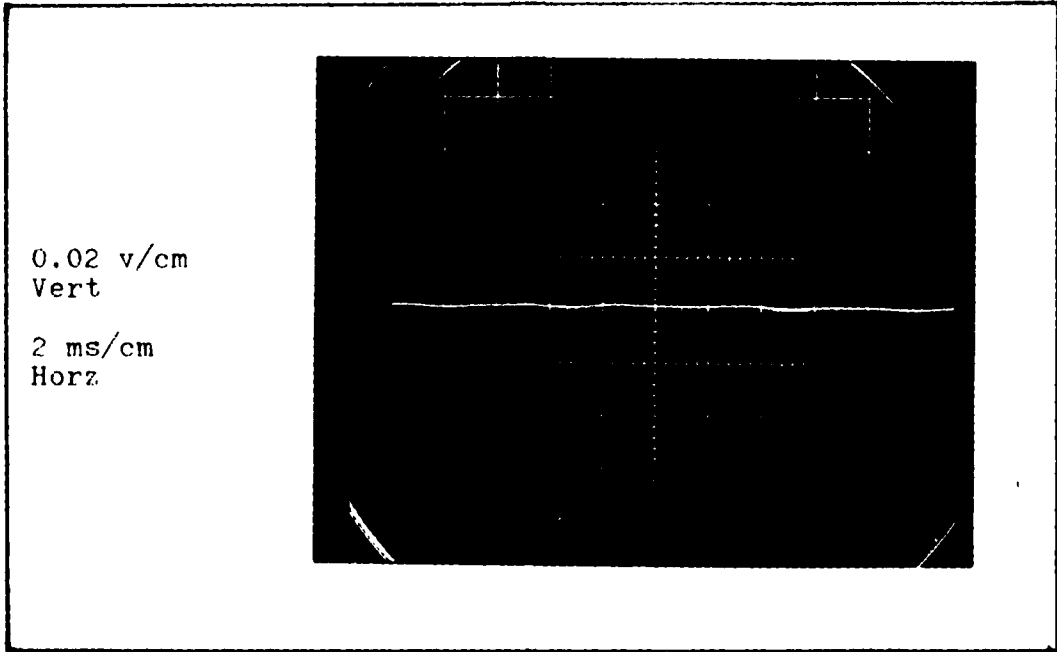

Figure D.4 Noise from Compensator Gc3a

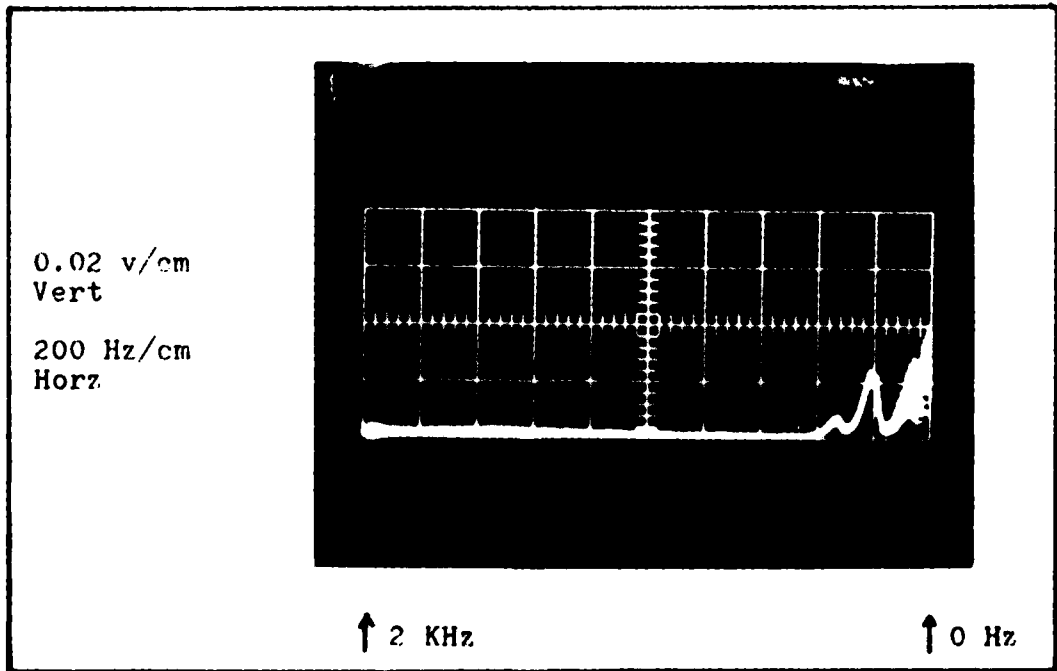

Figure D.5 Spectral Content of Noise from Compensator Gc3a

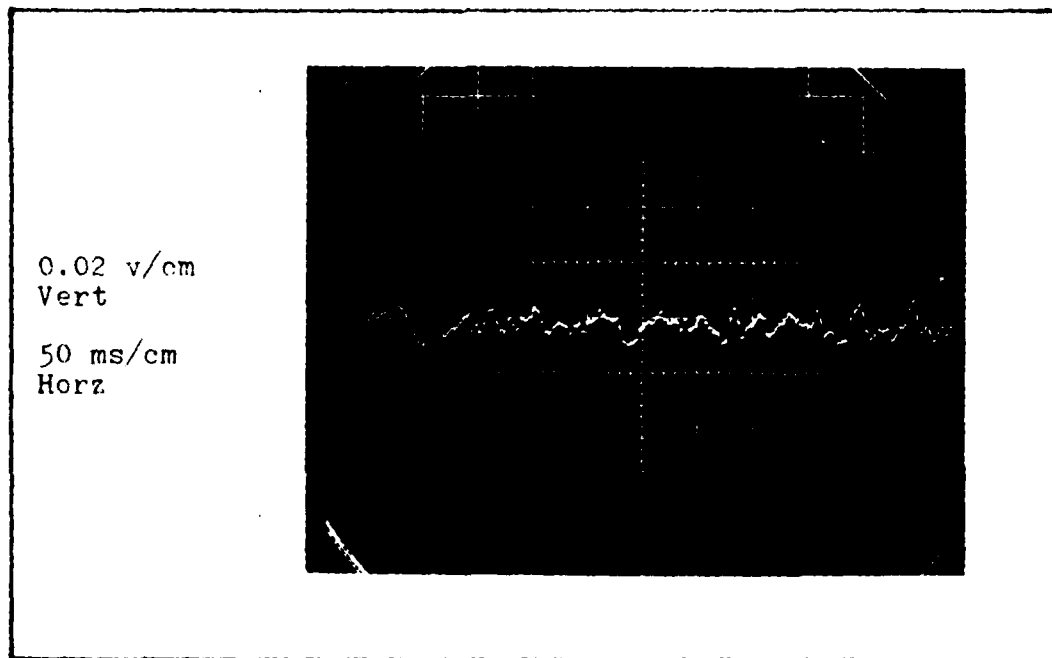

Figure D.6 Noise from Compensator  $G_{c3b}$

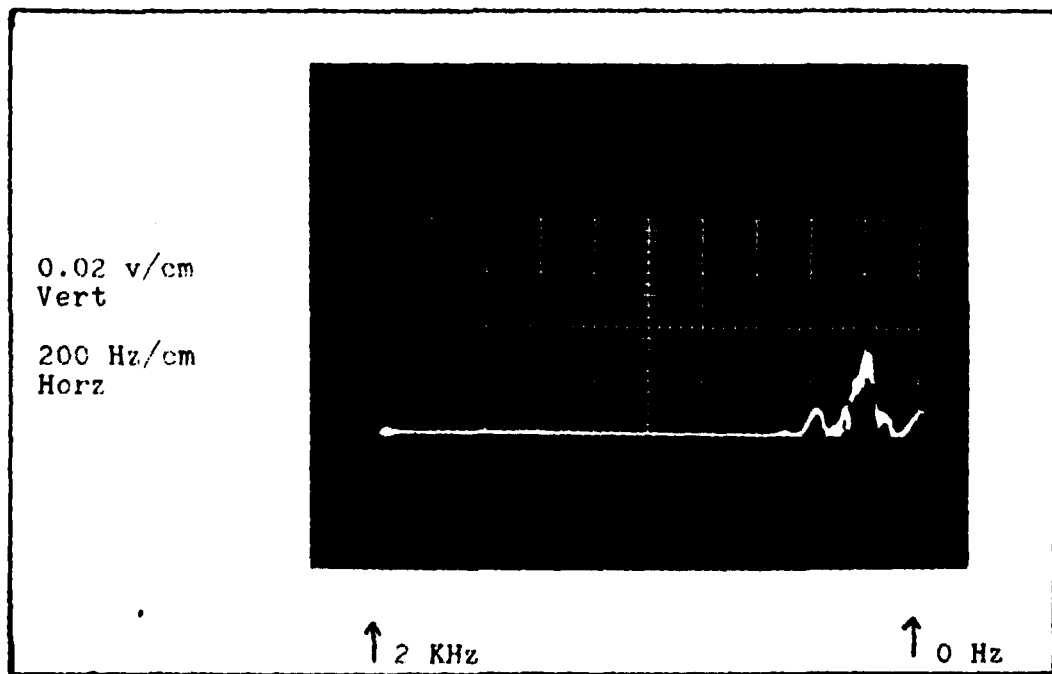
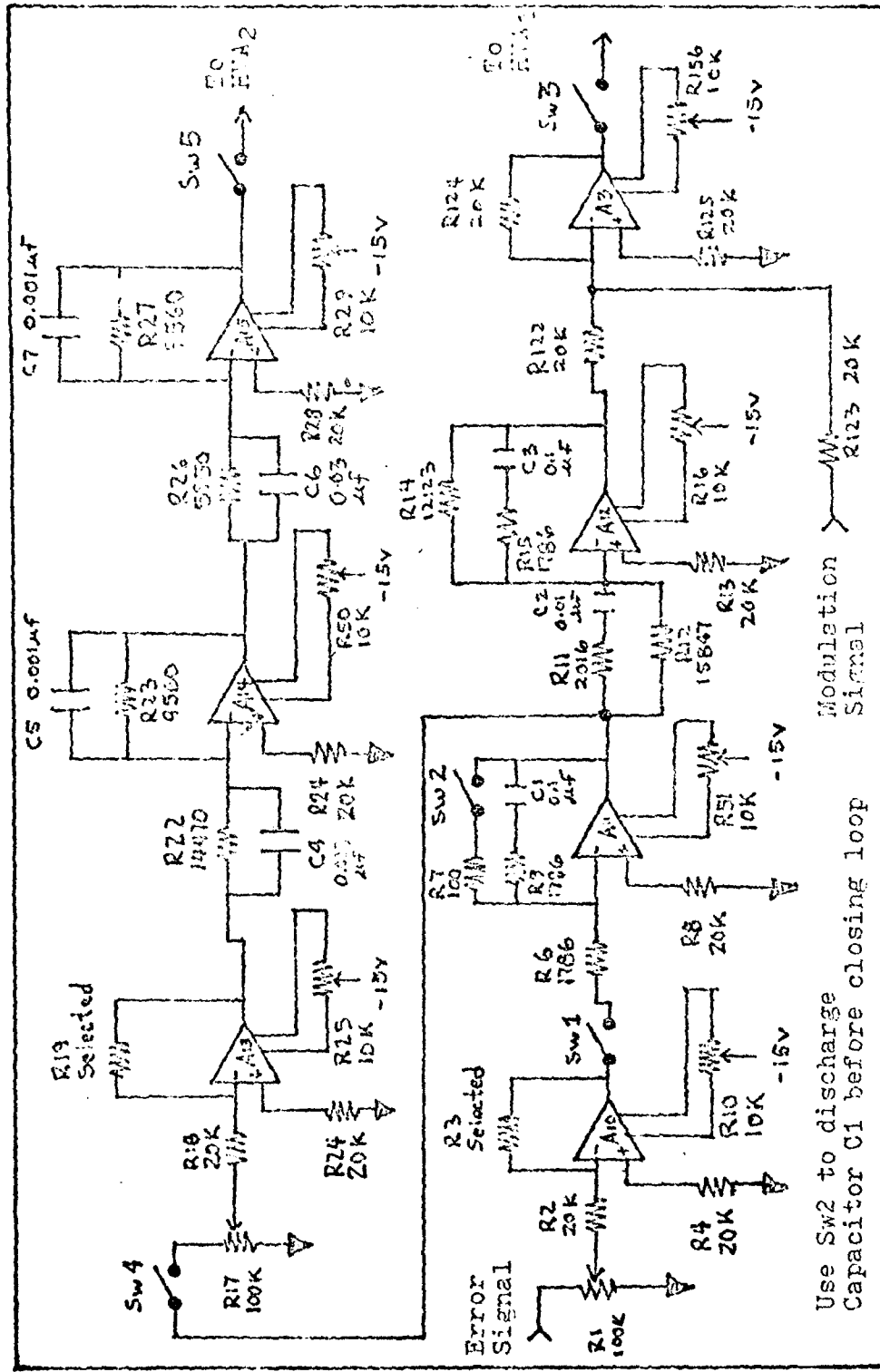

Figure D.7 Spectral Content of the Noise from Compensator  $G_{c3b}$



## Appendix E

### Experimental Procedure

#### Test Set-up

The laboratory and test site used in this experiment are located in the Air Force Institute of Technology Building 640, room 238, at Wright Patterson AFB, Ohio. Within the laboratory, the laser and interferometer were mounted on a one inch thick aluminum plate and placed on a layer of foam rubber to isolate them from table vibrations. The laser was also covered with a plastic shield to reduce the affects of acoustical noise and air currents. The interferometer was wrapped with styrofoam and tape to isolate it from temperature variations.

#### Test Procedure

The following is the test procedure to use in order to lock the laser to the interferometer resonance.

Step 1. With the system in a closed loop configuration, turn all of the compensator switches to off. This opens the loop and discharges the integrator capacitors.

Step 2. Connect the oscilloscope horizontal output to the summing amplifier side of the compensator output switch.

Step 3. Adjust  $HVA_1$  bias and gain control so that

a laser mode is detected on the oscilloscope from the detector output. With the LIA output also connected to the oscilloscope, the error signal will appear as a derivative of the detector signal.

Step 4. Maximize the error signal by adjusting the modulation frequency around 41 KHz.

Step 5. Rotate the LIA phase control to  $90^{\circ}$  and adjust the phase for a minimum error signal.

Step 6. Rotate the phase control to  $0^{\circ}$  and disconnect the oscilloscope horizontal output from the summing amplifier input.

Note: Steps 2 through 5 are accomplished to assure that the maximum derivative signal is achieved. It only needs to be performed about once a day.

Step 7. Manually adjust the interferometer power supply until the interferometer resonance matches a laser mode as seen by watching the detector output on the oscilloscope. If more than one mode is present, select the largest.

Step 8. Turn on all of the compensator switches.

With the above procedure completed, the laser will be locked to the interferometer resonance.

Appendix F

Equipment Listing

Equipment	Number Required
Laser Gain Tube, Spectra-Physics Model 120 .....	1
Mirrors, Dielectric	
Laser - 35 cm Radius of Curvature, 98% Reflective ..1	
- Flat, 99.9% Reflective .....	1
Piezoelectric Length Transducer, Channel Devices	
Navy Type 54, 1-1/2 inch .....	1
Navy Type 54, 1/2 inch .....	1
Laser Exciter, Spectra-Physics Model 249 .....	1
Interferometer, Jodon Model SA 1500 .....	1
Compensator Circuits (See Figures B.5, C.5, and D.8) ...	1
Chart Recorder, Gould Brush 200 Eight Channel .....	1
Lock-In-Amplifier, Princeton Applied Research	
Model HR-8 .....	1
High Voltage DC OP Amp, Burliegh Model PZ-70 .....	2
Electronic Counter, Hewlett Packard Model 5212 A .....	1
Oscilloscope, Tecktronix Model 565 .....	1
Oscilloscope, Lavoie Model 265 A .....	1
Spectrum Analyzer, Nelson-Ross PSA-016 Oscilloscope	
Plug-In Unit .....	1
Signal Generator, Wavetek Model 186 .....	1
Neutral Density Filter, Oriel Corp.	
Density Factor 1.2 .....	1
Power Supply, John Fluke Model 405B .....	1

## Vita

Robert D. Luzitano was born on 28 December 1944 in Fall River, Massachusetts. He graduated from San Bernardino High School in 1962 and entered the United States Air Force a month later. He received an Associate of Arts degree in Liberal Arts from Victor Valley College in 1969. He graduated from California State University at Sacramento in 1973 with a Bachelor of Science degree in Electrical Engineering. He received his commission from Officer Training School in December 1973 and worked as an avionics maintenance officer for the 93rd Avionics Maintenance Squadron at Castle AFB, California. He entered the School of Engineering, Air Force Institute of Technology, in June 1978 and pursued studies towards a Master of Science degree in Electrical Engineering. Captain Luzitano is scheduled to be assigned to the 6514th Test Squadron at Hill AFB, Utah upon completion of his studies.

UNCLASSIFIED

SECURITY CLASSIFICATION OF THIS PAGE (When Data Entered)

REPORT DOCUMENTATION PAGE		READ INSTRUCTIONS BEFORE COMPLETING FORM
1. REPORT NUMBER <b>AFIT/GE/EE/80-2</b>	2. GOVT ACCESSION NO. <b>AD-A085707</b>	3. RECIPIENT'S CATALOG NUMBER
4. TITLE (and Subtitle) <b>Comparison of Control Methods in a Frequency Stabilized Laser</b>		5. TYPE OF REPORT & PERIOD COVERED <b>M.S. Thesis</b>
6. AUTHOR <b>ROBERT LUZITANO CAPT A USAF</b>		6. PERFORMING ORG REPORT NUMBER
9. PERFORMING ORGANIZATION NAME AND ADDRESS <b>Air Force Institute of Technology (AFIT/EN) Wright-Patterson AFB Ohio 45433</b>		8. CONTRACT OR GRANT NUMBER(s)
11. CONTROLLING OFFICE NAME AND ADDRESS <b>Air Force Avionics Laboratory/RWA-2 Wright-Patterson AFB Ohio 45433</b>		10. PROGRAM ELEMENT & PROJECT TASK NUMBER
14. MONITORING AGENCY NAME & ADDRESS (if different from Controlling Office)		12. REPORT DATE <b>11</b>
		13. NUMBER OF PAGES <b>120</b>
		15. SECURITY CLASS (of this report) <b>UNCLASSIFIED</b>
		15a. DECLASSIFICATION/DOWNGRADING SCHEDULE
16. DISTRIBUTION STATEMENT (of this Report) <b>Approved for public release; distribution unlimited</b>		
17. DISTRIBUTION STATEMENT (of the abstract entered in Block 20, if different from Report)		
18. SUPPLEMENTARY NOTES <b>Approved for public release; IAW AFR 190-17 JOSEPH P. HIPPS Director of Public Affairs</b>		
19. KEY WORDS (Continue on reverse side if necessary and identify by block number) <b>Frequency Stabilized Laser Control of Laser Frequency</b>		
20. ABSTRACT (Continue on reverse side if necessary and identify by block number) <b>The purpose of this research is to compare two types of control methods that can be used to frequency stabilize a laser. The first method uses a single piezoelectric transducer (PZT) to control the cavity length of a helium neon laser. The second method employs dual PZT controllers of different lengths so that a fast response time can be achieved with the benefit of a large dynamic range. Two variations of the first method are compared to the second method. The first variation uses an integrator with gain as a compensator in</b>		

DD FORM 1473 1 JAN 73

EDITION OF 1 NOV 68 IS OBSOLETE

012225

UNCLASSIFIED

SECURITY CLASSIFICATION OF THIS PAGE (When Data Entered)

Joe

electronic feedback control loop and is designed using steady state analysis. The second variation uses a more sophisticated compensator that is designed using frequency analysis. Frequency analysis is also used in the compensator design for the second method. Each compensator is tested in a laser control loop and the results of each method are compared.

UNCLASSIFIED