

AD-A085 832

MB ASSOCIATES SAN RAMON CALIF  
XM746 PRACTICE FUZE. (U)  
MAR 80

F/G 19/1

DAAK10-79-C-0040  
NL

UNCLASSIFIED

For  
ALL  
79-832

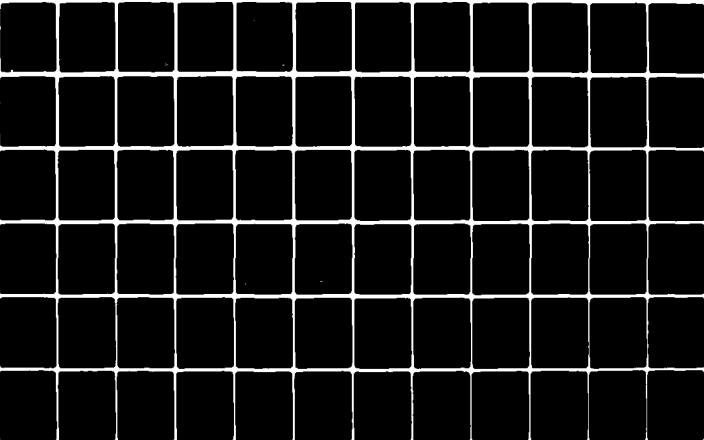

END  
DATE  
FILMED  
8-80  
DTIC

ADA 085832

6

XM746 PRACTICE FUZE.

F1083773

(J)  
SC

Progress Report

1 February through 28 Mar 1980

4

Progress Report, No. 4, Feb-28-11

Contract No. DAAK10-79-C-0040

12 86

Prepared for:

Department of the Army  
U. S. Army Armament Research and  
Development Command

REC'D  
JUN 1980

Prepared by:

MBAssociates/  
Bollinger Canyon Road  
San Ramon, California  
94583

DISTRIBUTION STATEMENT A  
Approved for public release;  
Distribution Unlimited

DC FILE COPY.

80 100 093

## 1.0 INTRODUCTION

This progress report covers the period February 1 through March 28, 1980 under Contract No. DAAK10-79-C-0040. This program is for the design and development of the XM746 Practice Fuze Spotting Charge.

### 1.1 Contract Add-On

In the month of February, MBA received a contract add-on of \$9,250 to fabricate and assemble 576 each XM747E2 (P/N 9331823) Practice Fuzes, of which 330 each were for ballistic testing at Ft. Sill, Oklahoma, and 246, less test quantities, for testing at ARRADCOM.

### 1.2 Static Testing

MBA, at the request of ARRADCOM, conducted a series of static tests using Red Phosphorus (RP) in combination with the MOD "E" composition to evaluate the possibility of the RP enhancing the smoke cloud density and duration.

The RP and MOD "E" were loaded into the GFE smoke containers, as shown in Figure 1. A cardboard disk was placed between the RP and MOD "E" composition to maintain the low sensitivity of the MOD "E" composition during handling. Loaded were 10 each RP/MOD "E" composition and 10 each standard composition MOD "E", see Table 1 for composition proportion.

The tests were recorded on video tape and instrumented with break wires at the fuze detonator and the projectile smoke ports in the same manner as all past testing, see Figure 2.

Table 2 lists the test sequence, composition weight and function times.

Reviewing the video tape (5 MBA personnel), it was agreed that the RP did not add to the smoke cloud density. Based on this input, ARRADCOM decided not to pursue this configuration.

Reviewing the function times of the MOD "E" composition revealed considerably longer function times than measured in past testing. An average time of 3.38 ms was recorded (see Table 2) in comparison to the September static test where the average time was 2.18 ms, see Table 3,

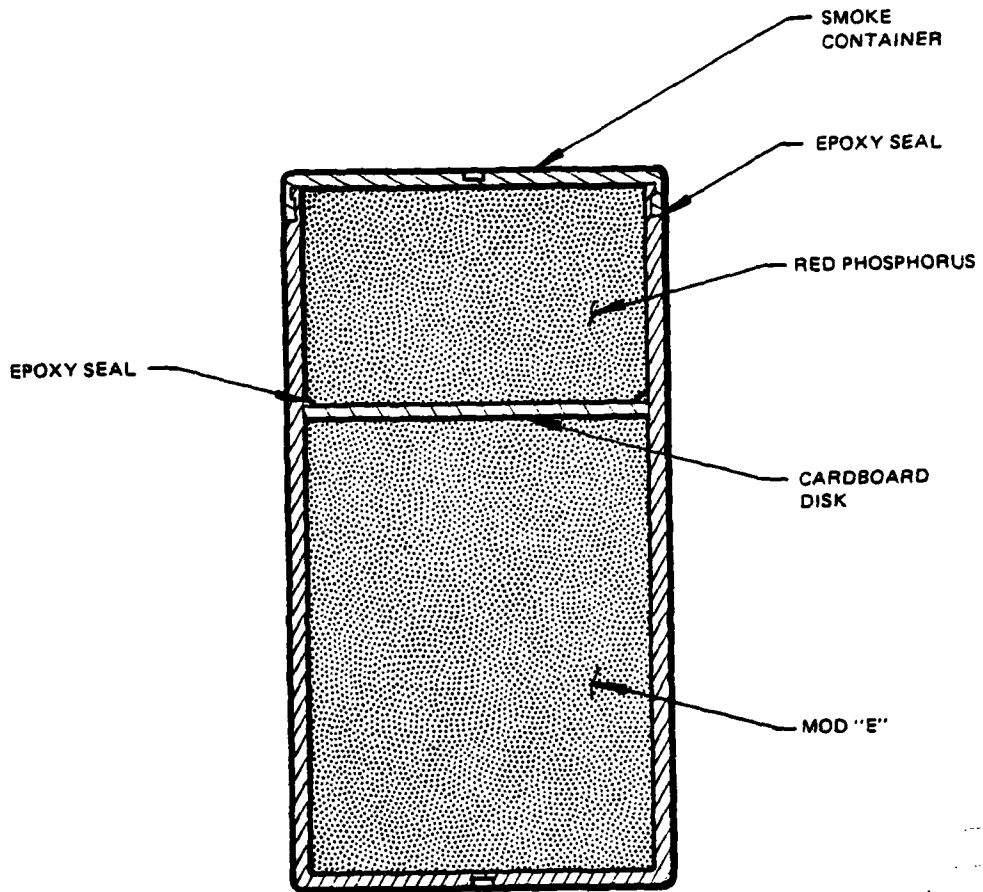

*Handwritten signature*

*A*

FIGURE 1  
MOD "E"/RED PHOSPHORUS CONFIGURATION

**MBA**  
0950-17017

TABLE 1  
COMPOSITION WT.

<u>FUZE S/N</u>	<u>MOD "E" WT. GRAMS</u>	<u>RED PHOSPHORUS WT. GRAMS</u>
250	33.5	7.5
251	32.9	7.1
252	33.4	7.4
253	32.7	8.0
254	32.8	7.4
<hr/>		
255	21.3	15.3
256	20.4	14.3
257	21.2	14.4
258	23.7	14.7
259	20.3	14.7
<hr/>		
260	45.7	-
261	45.4	-
262	45.9	-
263	46.5	-
264	46.2	-
265	45.2	-
266	45.1	-
267	45.0	-
268	44.8	-
269	46.3	-

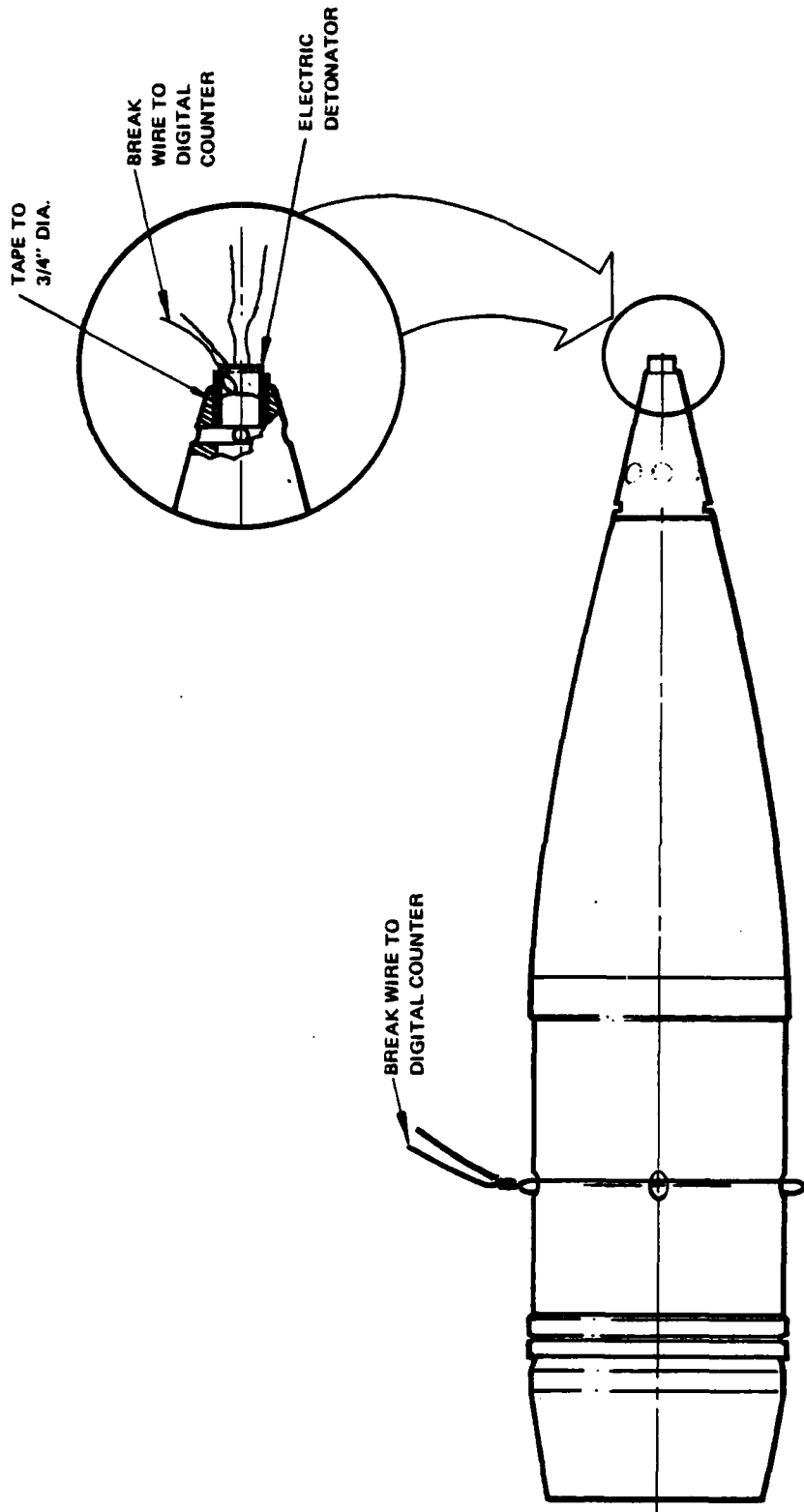

FIGURE 2  
 TYPICAL VELOCITY SCREEN

TABLE 2  
MOD "E"/RP STATIC TEST

<u>S/N</u>	<u>DESCRIPTION</u>	<u>TEMP.</u>	<u>WT, RP</u>	<u>WT, MOD "E"</u>	<u>TIME MS</u>
260	MOD "E"	AMB.	-	45.7	-
250	MOD "E"/RP	"	7.5	33.5	2.0
255	MOD "E"/RP	"	15.3	21.3	1.36
261	MOD "E"	"	-	45.4	3.19
251	MOD "E"/RP	"	7.1	32.9	3.80
256	MOD "E"/RP	"	14.3	20.4	4.20
262	MOD "E"	"	-	45.9	3.36
252	MOD "E"/RP	"	7.4	33.4	3.34
357	MOD "E"/RP	"	14.4	21.2	4.59
363	MOD "E"	"	-	46.5	3.23
353	MOD "E"/RP	"	8.0	32.7	1.52
358	MOD "E"/RP	"	14.7	23.7	4.47
364	MOD "E"	"	-	46.2	3.77
354	MOD "E"/RP	"	7.4	32.8	3.99
359	MOD "E"/RP	"	14.7	20.3	-
365	MOD "E"	"	-	45.2	-

TABLE 3  
XN747E STATIC TESTING (MBA)

LOT WHEN	S/N	SCREEN	LB MIXED	BLEND TIME	HUMIDITY	COMP WT GM	FUNC TIME MS	INTER- RUPT IN	FUZE TEMP	Outside temp.
MBA Qual. Testing Sept. 79	034	NO	1 #	2 HR	LO	47.55	1.678	-	AMB	90+
MBA Qual. Testing Sept. 79	036	NO	1 #	2 HR	LO	46.85	2.160	-	AMB	90+
MBA Qual. Testing Sept. 79	046	NO	1 #	2 HR	LO	46.60	2.691	-	AMB	90+
MBA Qual. Testing Sept. 79	047	NO	1 #	2 HR	LO	45.75	2.495	-	-50°F	90+
MBA Qual. Testing Sept. 79	053	NO	1 #	2 HR	LO	47.05	2.496	-	-30°F	90+
MBA Qual. Testing Sept. 79	052	NO	1 #	2 HR	LO	46.25	1.620	-	-30°F	90+
MBA Qual. Testing Sept. 79	051	NO	1 #	2 HR	LO	48.45	2.232	-	-30°F	90+
MBA Qual. Testing Sept. 79	066	NO	1 #	2 HR	LO	48.75	1.223	-	+140°F	90+
MBA Qual. Testing Sept. 79	068	NO	1 #	2 HR	LO	45.75	1.892	-	+140°F	90+
MBA Qual. Testing Sept. 79	067	NO	1 #	2 HR	LO	46.05	2.922	-	+140°F	90+
MBA Qual. Testing Sept. 79	070	NO	1 #	2 HR	LO	49.55	2.180	-	+140°F	90+
MBA Qual. Testing Sept. 79	069	NO	1 #	2 HR	LO	46.95	2.746	-	+140°F	90+
FT. Lewis Dec.79	FUNCTION	TEST ONLY 8 EACH	1 #	1 HR	HI	45.4	3.19	-	AMB	Outside temp. -60°F Batch Control
Pre Ft.S111 Feb80	261	NO	1 #	1 HR	HI	45.9	3.36	-	AMB	" "
Pre Ft.S111 Feb80	262	NO	1 #	1 HR	HI	46.5	3.23	-	AMB	" "
Pre Ft.S111 Feb80	263	NO	1 #	1 HR	HI	46.2	3.77	-	AMB	" "
Pre Ft.S111 Feb80	264	NO	1 #	1 HR	HI			-	AMB	" "

TABLE 3  
XN747E STATIC TESTING (MBA)

LOT WHEN	S/N	SCREEN	LB MIXED	BLEND TIME	HUMIDITY	COMP WT GM	FUNCT TIME MS	INTER- RUPT IN	FUZE TEMP	Notes
Pre Ft. S111 Feb80	310	YES	1 #	1 HR	HI	44.8	3.135	YES	AMB	Outside temp. -60°F Batch Ctrl.
Pre Ft. S111 Feb80	311	YES	1 #	1 HR	HI	46.2	2.460	YES	AMB	" "
Pre Ft. S111 Feb80	312	YES	1 #	1 HR	HI	45.10	3.442	YES	AMB	" "
Pre Ft. S111 Feb80	313	YES	1 #	1 HR	HI	45.5	2.98	-	AMB	" "
Pre Ft. S111 Feb80	314	YES	1 #	1 HR	HI	45.4	3.29	-	AMB	" "
Pre Ft. S111 Feb80	315	YES	1 #	1 HR	HI	45.2	3.14	-	AMB	" "
Ft. S111 Lot Feb. 80 (96 ea.)	316	YES	1 #	4 HR	HI	46.3	2.33	NP	AMB	" "
Ft. S111 Lot Feb. 80 (96 ea.)	317	YES	1 #	4 HR	HI	46.3	1.78	YES	AMB	" "
Ft. S111 Lot Feb. 80 (96 ea.)	318	YES	1 #	4 HR	HI	46.3	1.54	YES	AMB	" "
Ft. S111 Lot Feb. 80 (96 ea.)	319	NO	2 #	4 HR	HI	45.9	1.301	-	AMB	Belmont 3 case
Ft. S111 Lot Feb. 80 (96 ea.)	320	NO	2 #	4 HR	HI	45.8	1.710	-	AMB	Belmont 3 case
Ft. S111 Lot Feb. 80 (96 ea.)	321	NO	2 #	4 HR	HI	46.3	3.204	-	AMB	Belmont 3 case
Ft. S111 Lot Mar. 80 (96 ea.)	322	YES	2 #	4 HR	HI	45.9	3.12	NO	AMB	Outside Temp. 60°F Random Samp.
Ft. S111 Lot Mar. 80 (96 ea.)	323	NO	2 #	4 HR	HI	47.4	2.91	YES	AMB	" "
Ft. S111 Lot Mar. 80 (96 ea.)	324	NO	2 #	4 HR	HI	46.2	3.13	NO	AMB	" "
Ft. S111 Lot Mar. 80 (96 ea.)	325	NO	2 #	4 HR	HI	46.1	0	NO	AMB	" "
Ft. S111 Lot Mar. 80 (96 ea.)	326	NO	2 #	4 HR	HI	46.7	3.36	YES	AMB	" "

WK. FEB. 10

7

WK. FEB. 24

WK. FEB. 24

WK. MAR. 9

WK. MAR. 9

TABLE 3  
XN747E STATIC TESTING (MBA)

LOT WHEN	S/N	SCREEN	I.B. MIXED	BLEND TIME	HUMIDITY	COMP WT GM	FUNC TIME MS	INTER-RUPT IN	FUZE TEMP
Ft. S111 Lot Mar. 80 (96 ea.)	327	NO	2 #	4 HR	HI	45.8	3.14	YES	AMB
Ft. S111 Lot Mar. 80 (96 ea.)	328	YES	2 #	4 HR	HI	45.9	3.56	YES	AMB
Ft. S111 Lot Mar. 80 (96 ea.)	329	YES	2 #	4 HR	HI	47.4	2.66	YES	AMB
Ft. S111 Lot Mar. 80 #2	331	NO	2 #	4 HR	HI	46.2	3.12	YES	AMB

Outside temp.  
-60°F  
Random samp.

WR. MAR. 9

lines 1 through 13. As a result of the increased function times, the lot acceptance tests (LAT) for the Ft. Sill shipment included evaluating the composition particle size and blend times. The first 9 batches of the MOD "E" composition were screened through 325 micron screen. The zinc dust was analyzed in the Fisher sub-sieve sizer and particle size of the zinc dust averaged 5 microns, well within tolerance  $7 \pm 3$  microns stated on drawing 9331826, see Appendix A for blend control history.

At the conclusion of all testing, reviewing the data showed no real decrease in the function time, see Table 3. A further examination of the data revealed the relative humidity was higher in February 1980 than it was in September 1979. The relative humidity in the blending and loading areas was about 10% September and between 38 and 40% in February.

The mean averages for the function times and the standard deviations for both September and February test series were calculated using the following equation:

$$\bar{x} = \frac{\sum xi}{n} \quad \text{and } s = \left[ \frac{\sum (xi - \bar{x})^2}{n} \right]^{1/2}$$

For the September test series:

$$\bar{x} = 2.18 \text{ ms}, s = .49 \text{ ms} \quad (n = 13)$$

For the February test series:

$$\bar{x} = 2.87 \text{ ms}, s = .67 \text{ ms} \quad (n = 24)$$

The above results indicate that humidity could be a factor in causing an increase in the function time of the composition.

### 1.3

#### Ft. Sill Shipment

Two shipments were made to Ft. Sill, the first shipment was on February 29 containing 96 fuze assemblies which were LAT'd as outlined in Section 1.2. The second was on March 10, containing 234 fuze assemblies. Spotting charge function time LAT samples were pulled but not tested due to the ambitious delivery schedule.

1.4 Ballistic Testing\*

Ballistic testing of 60 practice fuzes (out of the first shipment of 96 fuzes) was conducted at Ft. Sill the week of 10 March. The tests had 5 forward observers stationed between 1500 through 4000 meters from the impact area. The F.O's reported slightly better than 50% spotting of the practice fuze smoke cloud with a fair to poor rating, see Table 4. As a result of the poor showing, the balance of the scheduled tests were cancelled.

1.5 ARRADCOM Meeting

A meeting was held at ARRADCOM on 18 March. The purpose was to discuss the poor ballistic test results at Ft. Sill per 1.4 above and review the related phenomena of increased function times being measured at MBA with the Ft. Sill and other recently manufactured units.

Before continuing the discussion, it is necessary for the reader to be aware that function time measurements of the Ft. Sill LAT units were not made until after the Ft. Sill units were shipped. However, LAT function only units were tested prior to shipment and were 100% successful. Thus, MBA was discovering the longer function times of the Ft. Sill LAT units at the same time the Ft. Sill ballistic tests were taking place.

The function time tests had to be deferred because there was not enough time to perform them prior to shipment and still meet the Ft. Sill test date. The extremely short schedule which required 2nd and some 3rd shift operations plus air shipment of both lots making up the 330 unit Ft. Sill delivery, precluded the normal LAT sequence.\*\*

In preparation for the meeting, MBA undertook a thorough review of the manufacturing procedures, hardware and materials used for the Ft. Sill units. This work included additional function time testing of ARRADCOM deliverable units now being held at MBA pending ARRADCOM direction. Function time results are presented in 1.2 above.

---

\* MBA personnel not present, data reported through ARRADCOM.

---

\*\*ARRADCOM aware of this deviation per telecon 2/26/80.

TABLE 4  
XM747E2 BALLISTIC TESTING

<u>DESCRIPTION</u>	<u>QUANTITY</u>	<u>TOTAL POSSIBLE OBSERVATIONS</u>	<u>NUMBER OBSERVED</u>	<u>RATING</u>
Zone 2 LA 284 to 599 mils	31	155	68	Poor
HI 991 to 1225 mils	8	40	21	Poor
Zone 3 LA 248 to 384 mils	8	40	36	Fair to Poor
Zone 5 LA 327 to 467 mils	8	40	32	Fair to Poor
HI 1186	5	25	0	-
TOTAL	60	300	157	

Note: The observed smoke signatures were obscured by dust clouds created on impact.

SUPPLIED BY ARRADCOM

The only identifiable difference or change in conditions discovered that could have affected function time was humidity. The MOD "E" (SW522) pyrotechnic composition for all prior fast function time units loaded by MBA, had been blended when the relative humidity was extremely low, slightly less than 10%.

The slower functioning fuzes manufactured in February contained pyrotechnics that had been blended and loaded when the relative humidity was at or near the maximum allowable value of 40%.

Certain metalized pyrotechnic compositions display more than normal sensitivity to moisture content. These mixtures typically need to be vacuum dried 0.10 to 0.20% absolute water content to achieve repeatable and fast burn rate performance (note the  $\approx$  37% increase in  $1\sigma$  times between the slow and fast units).

The possibility of "wet" pyrotechnic material being the cause of the increased function time was presented at the meeting. No consensus of opinion was reached on this subject, partially because it was determined that during ARRADCOM development of the SW522 composition, blending and loading took place at humidity levels well above RH's of 10%. However, it was agreed that some of the existing long function time units should be down loaded, the spotting charge vacuum dried then reloaded and tested to absolutely resolve the wetness question. MBA will do this after program completion in April or May at no cost to the Government.

A series of other decisions, not involving MBA, were made at the meeting. These involved ARRADCOM studies of the fuze train, additional work on the ARRADCOM MOD "E" (SW522) composition and the use of photo flash as a back-up spotting charge.

#### 1.6 Extended Evaluation of Smoke Intensity Test Results

The radiometric measurements shown in Table 5 have been corrected by the methods described in the Supplement to MBA Radiometric Procedures, MB-TM-79/02, see Appendix B, dated 27 August 1979. In addition, a correction for attenuation at the 40 foot range was made. The energy in

TABLE 5

## SMOKE TEST RESULTS FROM RADIOMETER MEASUREMENT (UNCORRECTED)

TEST	FUZE	DATE	I 1.7-2.8 Watts/Ster	I 3-5 Watts/Ster	TEMP °K	DURATION SEC	DELAY M.SEC+ 1
#38	#076	9/20/79	477	1491	840	.225	-
#39		9/20/79	438	1316	850	.084	17.5
#40		9/20/79	876	2140	900	.20	11.2
#41		9/20/79	494	1438	860	.19 .15	15
#42		9/20/79	374	1456	800	.19 .10	18.8
	#048	9/13/79	2789	5380	960	.175	3.0
#11	#030	9/11/79	4662	11094	910	.25	-
		9/11/79	1499	2523	1020	.20	-
	#025	9/11/79	2288	4474	960	.225	-

the measurement wavelength band was determined from the area under the curve and by assuming that energy is emitted uniformly from the source in all directions. The total energy of the source was then estimated independently from each wavelength band by dividing the energy in the wavelength band by the fraction of energy expected at that source temperature as determined from the procedure tables. This assumes black body emission from the source. All the corrected intensities, temperature, energy and black body fractions are shown in Table 6. Relatively good agreement between the total energy for each test was obtained.

The atmospheric corrections and corrections for the source temperature are relatively small and have a minor impact on results. The latter correction was based on extrapolated curves from the previously mentioned procedures on a very sensitive part of the curve. These corrections could have been rerun with the Lowtran computer program for atmospheric attenuation if they had a significant impact on the final result.

The error in the final intensity measurements caused by approximations made in the corrections for atmospheric conditions, source temperature and the different measurement distance (compared standard procedure) should not exceed 10%. This is the same order of magnitude as the basic measurement error.

#### 1.7 Program Extension

A request for a no cost contract change extending the program to 1 May has been made to allow time to determine the disposition of residual hardware and deliverable fuzes now in bonded storage at MBA.

Standard Conditions

Range .0229 KM  
 Altitude .1524 KM  
 Pressure 1000 MB  
 Temperature 21.1°C  
 Humidity 40%  
 Visibility 100 KM

Test Conditions

.0122 KM  
 .1524 KM  
 ~1000 MB  
 ~32.2°C  
 ~40%  
 ~100 KM

TABLE 6  
 SMOKE TESTS RADIOMETRIC MEASUREMENTS  
 CORRECTED FOR RANGE AND ATMOSPHERIC CONDITIONS

TEST	FUZE	INTENSITY 1.7-2.8µm RANGE (Watts/ Steradian)	INTENSITY 3-5 µm RANGE (Watts/ Steradian)	TEMP (°K)	ENERGY 3-5µm RANGE (Calories)	ENERGY 3-5µm RANGE AT TEMP (T) (%)	BLACKBODY FRACTION 1.7-2.8µm RANGE AT TEMP (T) (%)	BLACKBODY FRACTION 3-5µm RANGE AT TEMP (T) (%)	BLACKBODY ENERGY (TOTAL) (BAS- ED ON 1.7- 2.8µm RANGE) (Calories)	BLACKBODY ENERGY (TOTAL) (BASED ON 3-5µm RANGE) (Calories)
#38		636	1599	890	187	494	.146	.3578	1282	1381
#39		578	1410	900	98.5	247	.151	.359	652	689
#40		1111	2287	950	303	704	.175	.361	1733	1950
#41		648	1540	905	206	564	.153	.359	1346	1571
#42		515	1565	850	113	478	.126	.400	898	1195
#048	#048	3418	5754	1020	689	1350	.209	.359	3298	3760
#030	#030	5830	11855	960	1817	3371	.180	.362	10095	9313
		1806	2705	1080	433	778.5	.222	.353	1951	2205
#025	#025	2805	4786	1010	881	1587	.204	.360	4318	4409

APPENDIX A

PRACTICE FUZE

MOD-E TEST SAMPLES

2/8/80

SAMPLE #1

FUZE S/N

310

MOD-E S/N

169

NET WT.

44.835 GRAMS

SAMPLE #2

FUZE S/N

311

MOD-E S/N

149

NET WT.

46.155 GRAMS

SAMPLE #3

FUZE S/N

312

MOD-E S/N

197

NET WT.

45.145 GRAMS

100 SHEETS 100 SHEETS 100 SHEETS  
100 SHEETS 100 SHEETS 100 SHEETS



PRACTICE FUZE SMOKE CONTAINERS

PROJ.

S/N 149 B/N 020880-1  
 GROSS 51.940 GRAMS  
 TARE 5.785 GRAMS  
 NET 46.155 GRAMS

S/N B/N  
 GROSS  
 TARE  
 NET

S/N 169 B/N 020880-1  
 GROSS 50.665 GRAMS  
 TARE 5.830 GRAMS  
 NET 44.835 GRAMS

S/N B/N  
 GROSS  
 TARE  
 NET

S/N 197 B/N 020880-1  
 GROSS 50.965 GRAMS  
 TARE 5.820 GRAMS  
 NET 45.145 GRAMS

S/N B/N  
 GROSS  
 TARE  
 NET

S/N B/N  
 GROSS  
 TARE  
 NET

S/N B/N  
 GROSS  
 TARE  
 NET

S/N B/N  
 GROSS  
 TARE  
 NET

S/N B/N  
 GROSS  
 TARE  
 NET

S/N B/N  
 GROSS  
 TARE  
 NET

S/N B/N  
 GROSS  
 TARE  
 NET

S/N B/N  
 GROSS  
 TARE  
 NET

S/N B/N  
 GROSS  
 TARE  
 NET

S/N B/N  
 GROSS  
 TARE  
 NET

S/N B/N  
 GROSS  
 TARE  
 NET

50 SHEETS 1 SQUARE  
 100 SHEETS 1 SQUARE  
 250 SHEETS 1 SQUARE  
 NATIONAL

AMOUNT 1 lb.

SMOKE COMP. (PROJ. 069) P/N SU-522 B/N D20880-1 4/2

START 8:25

STOP 9:25

TEMP.

HUMIDITY

COMMENTS: THIS BLEND WAS BLENDED PER ARADCOM MOD-E SMOKE COMPOSITION BLENDING PROCEDURE FOR ONE (1) HR. 2/8/80

OVEN TEMP.	TIME: IN	TIME: OUT	TYPE OF CHEM.		
140°F	12/12 (12:00)	12/13 (10:30)	POTASSIUM PERCHLORATE		
140°F	12/12 (12:00)	12/13 (10:30)	POTASSIUM NITRATE		
140°F	12/13 (11:00)	12/14 (8:30)	ZINC POWDER		
140°F	12/13 (11:00)	12/14 (8:30)	ALUMINUM POWDER		

COMMENTS: Comp. blended in ball jar on ball mill, using 00rub stopper (50 ea.).

Comp. consists of;

ZINC POWDER - 181.45 GRAMS	Percentage by wt. 40%
ALUMINUM POWDER - 90.7 GRAMS	20%
POTASSIUM PERCHLORATE - 90.7 GRAMS	20%
POTASSIUM NITRATE - 90.7 GRAMS	20%

POTASSIUM PERCHLORATE  
MIL-P-217A  
GR. A - CL. 4

POTASSIUM NITRATE  
MIL-P-156B  
CL. 2

NOTE: THIS MATERIAL WAS PASSED THRU #325 (MESH TO THE INCH) SCREEN

NOTE: THIS MATERIAL WAS PASSED THRU #325 (MESH TO THE INCH) SCREEN

ALUMINUM POWDER

ZINC POWDER  
MIL-Z-365

MIL-P-14067A  
TYPE II 200/325 MESH  
NOTE: THIS MATERIAL WAS PASSED THRU #325 (MESH TO THE INCH) SCREEN

NOTE: THIS MATERIAL WAS PASSED THRU #325 (MESH TO THE INCH) SCREEN



PRACTICE FUZE SMOKE CONTAINERS

PROJ. 069

S/N 201 B/N 020880-1  
GROSS 51.30 G.  
TARE 5.82 G.  
NET 45.52 G.

S/N B/N  
GROSS  
TARE  
NET

S/N 212 B/N 020880-1  
GROSS 51.19 G.  
TARE 5.82 G.  
NET 45.37 G.

S/N B/N  
GROSS  
TARE  
NET

S/N 223 B/N 020880-1  
GROSS 51.005 G.  
TARE 5.820 G.  
NET 45.185 G.

S/N B/N  
GROSS  
TARE  
NET

S/N B/N  
GROSS  
TARE  
NET

S/N B/N  
GROSS  
TARE  
NET

S/N B/N  
GROSS  
TARE  
NET

S/N B/N  
GROSS  
TARE  
NET

S/N B/N  
GROSS  
TARE  
NET

S/N B/N  
GROSS  
TARE  
NET

S/N B/N  
GROSS  
TARE  
NET

S/N B/N  
GROSS  
TARE  
NET

S/N B/N  
GROSS  
TARE  
NET

S/N B/N  
GROSS  
TARE  
NET

10 SHEETS 9 SQUARE  
100 SHEETS 9 SQUARE  
200 SHEETS 9 SQUARE  
NATIONAL

PRACTICE FUZE TEST SAMPLES (MOD-E)

2/13/80

SAMPLE #1

FUZE S/N 316

MOD-E S/N 158

NET WT. 46.27G.

SAMPLE #2

FUZE S/N 317

MOD-E S/N 174

NET WT. 46.32G.

SAMPLE #3

FUZE S/N 318

MOD-E S/N 221

NET WT. 46.335G

50 SHEETS A SQUARE  
42 1/2 42 1/2 42 1/2 42 1/2  
42 1/2 42 1/2 42 1/2 42 1/2  
42 1/2 42 1/2 42 1/2 42 1/2



PRACTICE FUZE SMOKE CONTAINERS

PROJ.

S/N 158 B/N 021380-1  
 GROSS 52.10 G  
 TARE 5.83 G.  
 NET 46.27 G.

S/N B/N  
 GROSS  
 TARE  
 NET

S/N 174 B/N 021380-1  
 GROSS 52.15 G.  
 TARE 5.83 G.  
 NET 46.32 G.

S/N B/N  
 GROSS  
 TARE  
 NET

S/N 221 B/N 021380-1  
 GROSS 52.155 G  
 TARE 5.820 G.  
 NET 46.335 G.

S/N B/N  
 GROSS  
 TARE  
 NET

S/N B/N  
 GROSS  
 TARE  
 NET

S/N B/N  
 GROSS  
 TARE  
 NET

S/N B/N  
 GROSS  
 TARE  
 NET

S/N B/N  
 GROSS  
 TARE  
 NET

S/N B/N  
 GROSS  
 TARE  
 NET

S/N B/N  
 GROSS  
 TARE  
 NET

S/N B/N  
 GROSS  
 TARE  
 NET

S/N B/N  
 GROSS  
 TARE  
 NET

S/N B/N  
 GROSS  
 TARE  
 NET

S/N B/N  
 GROSS  
 TARE  
 NET

1 SQUARE  
 2 SQUARE  
 3 SQUARE  
 4 SQUARE  
 5 SQUARE  
 6 SQUARE  
 7 SQUARE  
 8 SQUARE  
 9 SQUARE  
 10 SQUARE  
 11 SQUARE  
 12 SQUARE  
 13 SQUARE  
 14 SQUARE  
 15 SQUARE  
 16 SQUARE  
 17 SQUARE  
 18 SQUARE  
 19 SQUARE  
 20 SQUARE  
 21 SQUARE  
 22 SQUARE  
 23 SQUARE  
 24 SQUARE  
 25 SQUARE  
 26 SQUARE  
 27 SQUARE  
 28 SQUARE  
 29 SQUARE  
 30 SQUARE  
 31 SQUARE  
 32 SQUARE  
 33 SQUARE  
 34 SQUARE  
 35 SQUARE  
 36 SQUARE  
 37 SQUARE  
 38 SQUARE  
 39 SQUARE  
 40 SQUARE  
 41 SQUARE  
 42 SQUARE  
 43 SQUARE  
 44 SQUARE  
 45 SQUARE  
 46 SQUARE  
 47 SQUARE  
 48 SQUARE  
 49 SQUARE  
 50 SQUARE  
 51 SQUARE  
 52 SQUARE  
 53 SQUARE  
 54 SQUARE  
 55 SQUARE  
 56 SQUARE  
 57 SQUARE  
 58 SQUARE  
 59 SQUARE  
 60 SQUARE  
 61 SQUARE  
 62 SQUARE  
 63 SQUARE  
 64 SQUARE  
 65 SQUARE  
 66 SQUARE  
 67 SQUARE  
 68 SQUARE  
 69 SQUARE  
 70 SQUARE  
 71 SQUARE  
 72 SQUARE  
 73 SQUARE  
 74 SQUARE  
 75 SQUARE  
 76 SQUARE  
 77 SQUARE  
 78 SQUARE  
 79 SQUARE  
 80 SQUARE  
 81 SQUARE  
 82 SQUARE  
 83 SQUARE  
 84 SQUARE  
 85 SQUARE  
 86 SQUARE  
 87 SQUARE  
 88 SQUARE  
 89 SQUARE  
 90 SQUARE  
 91 SQUARE  
 92 SQUARE  
 93 SQUARE  
 94 SQUARE  
 95 SQUARE  
 96 SQUARE  
 97 SQUARE  
 98 SQUARE  
 99 SQUARE  
 100 SQUARE



NATIONAL

AMOUNT 1 lb.

SMOKE COMP. (PROJ. 069) P/N SW-522 B/N 021380-1 4/12

START 9:00 A.M. STOP 1:00

TEMP. HUMIDITY  
 NOTE: MATERIAL WAS PASSED THRU #325 screen and dried in oven at 125°F from 2:00 PM on 2/12 to 8:00 AM on 2/13.  
 SMOKE COMP. WAS BLENDED FOR 4 HRS.

OVEN TEMP.	TIME: IN	TIME: OUT	TYPE OF CHEM.		
125°F	2/12 2:00	2/13 8:00	POTASSIUM PERCHLORATE		
125°F	2/12 2:00	2/13 8:00	POTASSIUM NITRATE		
125°F	2/12 2:00	2/13 8:00	ZINC POWDER		
125°F	2/12 2:00	2/13 8:00	ALUMINUM POWDER		

COMMENTS: Comp. blended in ball jar on ball mill, using corundum stoppers (50 ea.).

Comp. consists of; Percentage by wt.  
 ZINC POWDER - 181.4 GRAMS - 40%  
 ALUMINUM POWDER - 90.7 GRAMS - 20%  
 POTASSIUM PERCHLORATE - 90.7 GRAMS - 20%  
 POTASSIUM NITRATE - 90.7 GRAMS - 20%

POTASSIUM PERCHLORATE MIL-P-217A GR. A - CL. 4 P.O. # 69931	POTASSIUM NITRATE MIL-P-156B CL. 2 P.O. # 69930
ALUMINUM POWDER MIL-P-14067A TYPE II 200/325 MESH P.O. # 69929	ZINC POWDER MIL-Z-365 P.O. # 70240

PRACTICE FUZE TEST SAMPLES (MOD-E) 2/25/80

SAMPLE # 1

FUZE S/N 319

MOD-E S/N 280

NET WT. 45.9G.

SAMPLE # 2

FUZE S/N 320

MOD-E S/N 284

NET WT. 45.8G.

SAMPLE # 3

FUZE S/N 321

MOD-E S/N 293

NET WT. 46.3G.

43 SHEETS 1 SQUARE  
43 SHEETS 1 SQUARE  
43 SHEETS 1 SQUARE  
43 SHEETS 1 SQUARE  
NATIONAL

PRACTICE FUZE SMOKE CONTAINERS

PROJ. 069

S/N 280 B/N 022280-1  
 GROSS 51.6 G.  
 TARE 5.7 G.  
 NET 45.9 G.

S/N B/N  
 GROSS  
 TARE  
 NET

S/N 284 B/N 022280-1  
 GROSS 51.5 G.  
 TARE 5.7 G.  
 NET 45.8 G.

S/N B/N  
 GROSS  
 TARE  
 NET

S/N 293 B/N 022280-1  
 GROSS 52.0 G.  
 TARE 5.7 G.  
 NET 46.3 G.

S/N B/N  
 GROSS  
 TARE  
 NET

S/N B/N  
 GROSS  
 TARE  
 NET

S/N B/N  
 GROSS  
 TARE  
 NET

S/N B/N  
 GROSS  
 TARE  
 NET

S/N B/N  
 GROSS  
 TARE  
 NET

S/N B/N  
 GROSS  
 TARE  
 NET

S/N B/N  
 GROSS  
 TARE  
 NET

S/N B/N  
 GROSS  
 TARE  
 NET

S/N B/N  
 GROSS  
 TARE  
 NET

S/N B/N  
 GROSS  
 TARE  
 NET

S/N B/N  
 GROSS  
 TARE  
 NET

42 SHEETS 1 SQUARE  
 42 SHEETS 1 SQUARE  
 42 SHEETS 1 SQUARE



NATIONAL

AMOUNT 907.16

SMOKE COMP. (PROJ. 069) P/N SW-522 B/N 022280-1 4/2

START 11:30 STOP 3:30

TEMP. 68°F HUMIDITY

Material was not screened.

TEMP.	TIME: IN	TIME: OUT	TYPE OF CHEM.
100°F	8:00 (2/21)	10:30 (2/22)	POTASSIUM PERCHLORATE
100°F	8:00 (2/21)	10:30 (2/22)	POTASSIUM NITRATE
100°F	8:00 (2/21)	10:30 (2/22)	ZINC POWDER
100°F	8:00 (2/21)	10:30 (2/22)	ALUMINUM POWDER

COMMENTS: Comp. blended in ball jar on ball mill, using 00 mesh  
toppers (50 ea.).

Comp. consists of:

ZINC POWDER	362.9 GRAMS	40%
ALUMINUM POWDER	181.4 GRAMS	20%
POTASSIUM PERCHLORATE	181.4 GRAMS	20%
POTASSIUM NITRATE	181.4 GRAMS	20%

POTASSIUM PERCHLORATE  
MIL-P-217A  
R.A - CL. 4  
P.O.# 69936

POTASSIUM NITRATE  
MIL-P-156B  
CL. 2  
P.O.# 69930

ALUMINUM POWDER  
MIL-P-14067A  
TYPE II 200/325 MESH  
P.O.# 69929

ZINC POWDER  
MIL-Z-365  
P.O.# 70240

PRACTICE FUZE TEST SAMPLES (MOD-E)

3/7/80

BATCH SAMPLES FROM W/O # 800221

B/N	FUZE S/N	NET WT.
022680-1	322	45.9
022780-2	323	47.4
022780-4	324	46.2

BATCH SAMPLES FROM W/O # 800301-1

B/N	FUZE S/N	NET WT.
030480-3	325	46.1
022980-1	326	46.7
030380-1	327	45.8

50 SHEETS SQUARE  
100 SHEETS SQUARE  
200 SHEETS SQUARE  
NATIONAL

SMOKE COMP (PROJ. 069) P/NSW-522 B/NO22680-1 4/12

START 10:30 STOP 2:30  
 TEMP. 70°F HUMIDITY 60%  
 MATERIAL WAS PASSED THRU #325 SCREEN

OVEN TEMP.	TIME: IN	TIME: OUT	TYPE OF CHEM.
140°F	2/22 3:45	2/25 9:00	POTASSIUM PERCHLORATE
140°F	2/22 3:45	2/25 9:00	POTASSIUM NITRATE
140°F	2/25 9:00	2/26 9:00	ZINC POWDER
140°F	2/25 9:00	2/26 9:00	ALUMINUM POWDER

COMMENTS: Comp. blended in ball jar on ball mill, using cork stoppers (50 ea.).

Comp. Consists of; Percentage by wt.  
 ZINC POWDER - 362.9 GRAMS - 40%  
 ALUMINUM POWDER - 181.4 GRAMS - 20%  
 POTASSIUM PERCHLORATE - 181.4 GRAMS - 20%  
 POTASSIUM NITRATE - 181.4 GRAMS - 20%

POTASSIUM PERCHLORATE MIL-P-217A GR. A - CL. 4 P.O. # 69931	POTASSIUM NITRATE MIL-P-156B CL. 2 P.O. # 69930
ALUMINUM POWDER MIL-P-14067A TYPE II 200/325 MESH P.O. # 69929	ZINC POWDER MIL-Z-365 P.O. # 70993

AMOUNT 967.1G.

SMOKE COMP (PROJ. 069) P/N SW-522 Q/N 022780-2 4/12

START 6:30

STOP 10:30

TEMP.

HUMIDITY

MATERIAL WAS ~~LEFT~~ LEFT IN THE OVEN UNTIL READY TO BE WEIGHED FOR BLENDS. COOLED IN DESICCATOR BEFORE WEIGHING.

OVEN TEMP.	TIME: IN	TIME: OUT	TYPE OF CHEM.		
140°F			POTASSIUM PERCHLORATE		
140°F			POTASSIUM NITRATE		
140°F			ZINC POWDER		
140°F			ALUMINUM POWDER		

COMMENTS: Comp. blended in ball jar on ball mill, using 00rub stoppers (50 ea.).

Comp. Consists of;

ZINC POWDER - 362.9 GRAMS	Percentage by wt.
ALUMINUM POWDER - 181.4 GRAMS	40%
POTASSIUM PERCHLORATE - 181.4 GRAMS	20%
POTASSIUM NITRATE - 181.4 GRAMS	20%

POTASSIUM PERCHLORATE MIL-P-217A GR. A - CL. 4 PO # 69931	POTASSIUM NITRATE MIL-P-156B CL. 2 PO # 69930
--	--

ALUMINUM POWDER MIL-P-14067A TYPE II 200/325 MESH PO # 69929	ZINC POWDER MIL-Z-365 JAN PO # 70993
---	---

AMOUNT

SMOKE COMP. (PROJ. 069) P/N SW-522 8/N 022780-4 4/12

START 3:00

STOP 8:00

TEMP.

HUMIDITY

MATERIAL WAS STORED IN THE OVEN UNTIL READY TO BE WEIGHED FOR BLENDING. COOLED IN DESICCATOR BEFORE WEIGHING.

OVEN TEMP.	TIME: IN	TIME: OUT	TYPE OF CHEM.
140°F			POTASSIUM PERCHLORATE
140°F			POTASSIUM NITRATE
140°F			ZINC POWDER
140°F			ALUMINUM POWDER

COMMENTS: Comp. blended in ball jar on ball mill, using 50 rubber stoppers (50 ea.).

Comp. consists of;

	Percentage by wt.
ZINC POWDER - 362.9 GRAMS	40%
ALUMINUM POWDER - 181.4 GRAMS	20%
POTASSIUM PERCHLORATE - 181.4 GRAMS	20%
POTASSIUM NITRATE - 181.4 GRAMS	20%

POTASSIUM PERCHLORATE

MIL-P-217A

SR. A - CL. 4

PO # 69931

POTASSIUM NITRATE

MIL-P-156B

CL. 2

PO # 69930

ALUMINUM POWDER

MIL-P-14067A

TYPE II 200/325 MESH

PO # 69929

ZINC POWDER

MIL-Z-365

JAN

PO # 70993

AMOUNT

SMOKE COMP (PRN). 069) P/N SW-522 Q/N 022980-1 4/12

START 7:30 STOP 11:30

TEMP. HUMIDITY

MATERIAL WAS STORED IN THE OVEN UNTIL READY TO BE WEIGHED FOR BLENDING. COOLED IN DESICCATOR BEFORE WEIGHING.

OVEN TEMP.	TIME: IN	TIME: OUT	TYPE OF CHEM.		
140°F			POTASSIUM PERCHLORATE		
140°F			POTASSIUM NITRATE		
140°F			ZINC POWDER		
140°F			ALUMINUM POWDER		

COMMENTS: Comp. blended in ball jar on ball mill, using 00rub. stoppers (50 ea.).

Comp. Consists of; Percentage by wt.

ZINC POWDER - 369.2 GRAMS - 40%

ALUMINUM POWDER - 181.4 GRAMS - 20%

POTASSIUM PERCHLORATE - 181.4 GRAMS - 20%

POTASSIUM NITRATE - 181.4 GRAMS - 20%

POTASSIUM PERCHLORATE MIL-P-217A SR. A - CL. 4 PO # 69931	POTASSIUM NITRATE MIL-P-156B CL. 2 PO # 69930
ALUMINUM POWDER MIL-P-14067A TYPE II 200/325 MESH PO # 69929	ZINC POWDER MIL-Z-365 JAN PO # 70993

AMOUNT 907.1

SMOKE COMP. (PROJ. 069) P/NSW-522 8/NO30380-1 4/12

START 8:30

STOP 12:30

TEMP.

HUMIDITY

MATERIAL WAS STORED IN OVEN UNTIL READY TO BE WEIGHED.  
COOLED IN DESICCATOR BEFORE WEIGHING.

OVEN TEMP.	TIME: IN	TIME: OUT	TYPE OF CHEM.		
140°F			POTASSIUM PERCHLORATE		
140°F			POTASSIUM NITRATE		
140°F			ZINC POWDER		
140°F			ALUMINUM POWDER		

COMMENTS: Comp. Blended in ball jar on ball mill, using coruh stopper (50 ea.).

Comp. Consists of; Percentage by wt.  
 ZINC POWDER - 362.9 GRAMS - 40%  
 ALUMINUM POWDER - 181.4 GRAMS - 20%  
 POTASSIUM PERCHLORATE - 181.4 GRAMS - 20%  
 POTASSIUM NITRATE - 181.4 GRAMS - 20%

POTASSIUM PERCHLORATE

MIL-P-217A

GR. A - CL. 4

PO # 69931

POTASSIUM NITRATE

MIL-P-156B

CL. 2

PO # 69930

ALUMINUM POWDER

MIL-P-14067A

TYPE II 200/325 MESH

PO # 69929

ZINC POWDER

MIL-Z-365

JAN

PO # 70993

AMOUNT 907.16

SMOKE COMP. (PROJ. 069) P/N S11-522 B/N 030480-3 4/12

START 4:10 pm

STOP 8:10 pm

TEMP.

HUMIDITY

Material was stored in the oven until ready to be weighed. Cooled in desiccator before weighing.

OVEN TEMP.	TIME: IN	TIME: OUT	TYPE OF CHEM.
140°F			POTASSIUM PERCHLORATE
140°F			POTASSIUM NITRATE
140°F			ZINC POWDER
140°F			ALUMINUM POWDER

COMMENTS: Comp. blended in ball jar on ball mill, using 00 rubb stoppers (50 ea.).

Comp. Consists of;

Percentage by wt.

ZINC POWDER - 362.9 GRAMS - 40%

ALUMINUM POWDER - 181.4 GRAMS - 20%

POTASSIUM PERCHLORATE - 181.4 GRAMS - 20%

POTASSIUM NITRATE - 181.4 GRAMS - 20%

POTASSIUM PERCHLORATE

MIL-P-217A

SR. A - CL. 4

PO # 69931

POTASSIUM NITRATE

MIL-P-156B

CL. 2

PO # 69930

ALUMINUM POWDER

MIL-P-14067A

TYPE II 200/325 MESH

PO # 69929

ZINC POWDER

~~MIL~~ - Z - 365

JAIN

PO # 70993



AMOUNT 907.16

SMOKE COMP. (PRO. 069) P/N SW-522 B/N 022680-2 4/12

2/26/80 STOP 2/27/80  
START 2:55 4:30 ~~RESTARTED~~ - 9:00 STOP - 11:40

TEMP.

HUMIDITY

MATERIAL WAS PASSED THRU #325 MESH SCREEN

TEMP.	TIME: IN	TIME: OUT	TYPE OF CHEM.		
140°F	2/25 3:45	2/25 9:00	POTASSIUM PERCHLORATE		
140°F	2/25 3:45	2/25 9:00	POTASSIUM NITRATE		
140°F	2/25 9:00	2/26 9:00	ZINC POWDER		
140°F	2/25 9:00	2/26 9:00	ALUMINUM POWDER		

COMMENTS: Comp. Blended in ball jar on ball mill, using 500ml stoppers (50 ea.).

Comp. Consists of;

ZINC POWDER - 362.9 GRAMS -	40%
ALUMINUM POWDER - 181.4 GRAMS -	20%
POTASSIUM PERCHLORATE - 181.4 GRAMS -	20%
POTASSIUM NITRATE - 181.4 GRAMS -	20%

POTASSIUM PERCHLORATE  
MIL-P-217A  
SR. A - CL. 4  
P.O. # 69931

POTASSIUM NITRATE  
MIL-P-156B  
CL. 2  
P.O. # 69930

ALUMINUM POWDER  
MIL-P-14067A  
TYPE II 200/325 MESH  
P.O. # 69929

ZINC POWDER  
MIL - Z - 365  
S.A.V.  
P.O. # 70993

AMOUNT

SMOKE COMP. (PROJ. 069) P/N SW-522 Q/N 022780-3 4/12

START 10:40

STOP 2:40

TEMP.

HUMIDITY

MATERIAL WAS LEFT IN THE OVEN UNTIL READY TO BE WEIGHED FOR BLENDING. COOLED IN DESICCATOR BEFORE WEIGHING.

OVEN TEMP.	TIME: IN	TIME: OUT	TYPE OF CHEM.	
			<del>POTASSIUM</del>	<del>NITRATE</del>
140°F			POTASSIUM PERCHLORATE	
140°F			POTASSIUM NITRATE	
140°F			ZINC POWDER	
140°F			ALUMINUM POWDER	

COMMENTS: Comp. blended in ball jar on ball mill, using 50 rubber stoppers (50 ea.).

Comp. consists of;

Percentage by wt.

ZINC POWDER - 362.9 GRAMS - 40%

ALUMINUM POWDER - 181.4 GRAMS - 20%

POTASSIUM PERCHLORATE - 181.4 GRAMS - 20%

POTASSIUM NITRATE - 181.4 GRAMS - 20%

POTASSIUM PERCHLORATE

MIL-P-217A

GR. A - CL. 4

PO # 69931

POTASSIUM NITRATE

MIL-P-156B

CL. 2

PO # 69930

ALUMINUM POWDER

MIL-P-14067A

TYPE II 200/325 MESH

PO # 69929

ZINC POWDER

MIL-Z-365

JAN

PO # 70993

# certificate of analysis



**G.W.** Natural  
Resources  
Group

GULF WESTERN INDUSTRIES INC.

The New Jersey Zinc Company  
Palmerton, Pa.

January 10, 1980-1g

**MATERIAL** ZINC DUST-44

**CUSTOMER** The New Jersey Zinc Co.  
c/o A. J. Lynch Whse. Co.  
4560 East 50th Street  
Los Angeles, Calif. 90058

PO# 70993

## ANALYSIS

Lot Number H-6538

### Screen Test

On 325 Mesh Screen	3.0 %
Th 325 Mesh Screen	97.0 %

### Chemical

Metallic Zinc	96.9 %
Pb	0.13 %
Cd	0.02 %
CaO	0.01 %
0 - 10 Microns	64

Misc   
18 JAN 80

MISC

RECEIVED  
JAN 17 1980  
MBA PURCHASING  
PROPERTY CONTROL

  
S. N. Roeder  
Supt., Testing Dept.



# Belmont METALS INC.

330 BELMONT AVENUE · BROOKLYN, NEW YORK 11207

DIVISION OF  
BELMONT SMELTING &  
REFINING WORKS, INC.

TWX 710-584-2296  
TEL. 212 342-4900

SEPTEMBER 1979

M.B. ASSOCIATES, INC.  
BOLLANGER CANYON RD.  
SAN RAMON, CALIF. 94583

Gentlemen:

Misc

MIL  
STD  
118

9 OCT 79

CONFORMANCE

CERTIFICATE OF

Order No.: 70240

Belmont Order No.: 06552

Material: 10.LB BELMONT HIGH GRADE ZINC POWDER NO. 325

Shipped:

This is to certify that your order has been manufactured in  
accordance with the following specifications:

MIL-Z-365

BELMONT SMELTING & REFINING WORKS, INC.

*Pete Trivier*  
*Sales Rep*



# VALIMET - INSPECTION CERTIFICATE

MIL P 14067B

Consigned to: M. B. ASSOCIATES Bollinger Canyon Road San Ramon, CA 94583	Quantity in this shipment: 25 lbs, Batch 78-9230, Lot 001 <hr/> Packing of shipment: 1 Fiber Drum @ 25# Net Wt.
Item: Aluminum Metallic Powder	Specification: Mil P-14067B (MU) Type II
Shipped via:  Federal Express	Contract or P.O. number:  69929 <hr/> Date shipped: 8-24-79

  
*Misc*  
6917

It is certified that the following is an analysis of tests prescribed for the above item as required in applicable certification.

Test required	Specified limits or requirements	No. tested	Test Values obtained
Aluminum	98.75% min.	All	99.24
Iron	0.55 max.		0.15
Zinc	0.3 max.		0.003
Silicon	0.25 max.		0.15
Volatiles @ 105°C	0.1 max.		0.030
Oil & Grease	0.2 max.		0.032
Particle Distribution	% by wt.		
-200	99.5% min.		99.9
-325	60.0% min.		75.5
Apparent Density	1.0 gm./cc		1.11 gm./cc

VALIMET, INC. 431 East Sperry Road — Stockton, California 95206	Name and title of official: Quality Control: <i>W. T. Lang</i> Date: August 27, 1979
--	--

RECEIVED  
 NOV 19 1979

State of CALIFORNIA  
 County of SAN JOAQUIN

As subscribed and sworn to before me, a notary public in and for the state and county aforesaid, this 27th day of August, 1979.

Notary Seal

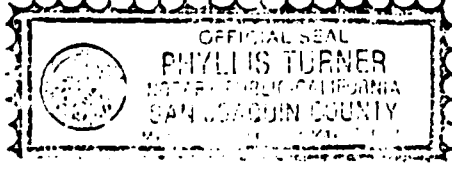

M.B.A. PROPERTY CONTROL  
 AUG 27 1979

Notary Public

SALES CONFIRMATION

CROTON  
CHEMICAL  
COMPANY

10 HARMICH ROAD  
SOUTH PLAINFIELD  
NEW JERSEY 07080

Telephone 201-754 2900

Shipments will be made to: (address  
as left if none other noted)

M. B. Associates  
P.O. Box 196  
San Ramon, CA 94583

M.B. Associates  
Bollinger Canyon Road  
San Ramon, CA 94583

GENTLEMEN:

Your Order No. Verbal of 8/17/79 has been received 8/17/79  
and entered as follows. F.O.B. our plant, South Plainfield, N. J. (unless otherwise noted below):

Line	Quantity Ordered	Packing	DESCRIPTION	Code	Price Per Pound
A	1	25 lbs.	POTASSIUM NITRATE MIL-P-156B, Cl. II, Amend. 1 Certificate of Compliance		\$100.00/lot 25.00

RECEIVED  
AUG 20 1979  
MBA PURCHASING  
PROPERTY CONTROL

SCHEDULED FOR SHIPMENT: On or before 8/21/79  
Federal Express - Collect

PAYMENT TERMS: Net 30 days

PLEASE REFER TO OUR ORDER NO. C-2143

We appreciate your order.

Very truly yours,  
CROTON  
CHEMICAL  
COMPANY

by Robert Fagan, Administrative Assistant  
Authorized Signature

**CERTIFICATE OF COMPLIANCE  
AND ANALYSIS**

Purchase Order No.

Item name and number

POTASSIUM NITRATE

To:

M.B. Associates  
P.O. Box 196  
San Ramon California 94583

Lot number

KN-9-231

shipped (mo, day, yr)

August 21 1979

shipped via

Federal Air Express

consigned to:

M.B. Associates  
Bollinger Canyon Road  
San Ramon California 94583

quantity shipped

25 lbs.

shipping order

C-2143

packing

25 lb. net fiber drum

IT IS HEREBY CERTIFIED that material, as shipped above, conforms with Specification

MII-P-156B

dated

and

Class II, Amend. 1

and all applicable waivers and changes

It is further certified that the following are the Specification requirements, together with our laboratory's analysis:

test prescribed	specification limits		analytical results
	maximum	minimum	
Moisture	0.2%		0.16%
Water Insoluble Matter	0.1%		0.05%
Chlorides, as Potassium Chloride	0.07%		0.05%
Chlorates & Perchlorates as KClO <sub>4</sub>	0.5%		0.035%
Iron & Aluminum as oxide	0.5%		0.03%
Ca & Mg as oxides	0.5%		0.35%
Sodium as oxides	0.25%		0.18%
Nitrogen		13.77%	13.92%
pH Value	8	6	6.9
Granulation thru #20 USS Sieve		95.0%	96.0%

name of company

Croton Chemical Company

name and title of official

B.F. Schoen Vice-President

date

August 21 1979

**BARIUM AND CHEMICALS, INC.**  
**STUEBENVILLE, OHIO**

<b>CERTIFICATE OF COMPLIANCE AND ANALYSIS</b>  Att - Quality Control Buyer - M. R. Corynen		PROCUREMENT ORDER No.	PURCHASE ORDER No. <b>69931</b>
		THIS IS TO CERTIFY THAT (Item name and number) <b>POTASSIUM PERCHLORATE Gr A - Cl 4</b>	
TO:  <b>MB Associates Box 196 San Ramon, California 94583</b>		LOT NUMBER <b>BCQ-1-1</b>	SHIPPED (Month, Day, Year) <b>Aug. 22, 1979</b>
		SHIPPED VIA <b>Federal Exp</b>	CAR INITIALS AND No.
		WEIGHT (Total Net Pounds) <b>25 lbs.</b>	B/L NUMBER
		DELIVERY ORDER No.	QUANTITY <b>25 lbs.</b>
CONSIGNEE TO  <b>Sams - Bollinger Canyon Road San Ramon, California 94583</b>		SHIPPING ORDER No. <b>29380</b>	
<del>RECEIVED</del> ITEM NUMBERS <b>1 carton containing 3 cans (2x8# ea., 1x9#)</b>		MARKED <b>POTASSIUM PERCHLORATE Gr A - Cl 4</b>	MEETS ALL THE REQUIREMENTS OF CONTRACT No. <b>69931</b>
IT IS FURTHER CERTIFIED THAT THE FOLLOWING IS AN ANALYSIS OF THE ABOVE MATERIAL, COVERING DETAILED REQUIREMENTS OF APPLICABLE SPECIFICATION NUMBER <b>MIL-P-217A</b> DATED _____ AND _____			

LIST APPLICABLE AUTHORIZED WAIVERS AND CHANGES

TEST PRESCRIBED	SPECIFICATION LIMITS		ANALYTICAL RESULT
	MAXIMUM	MINIMUM	
Moisture	0.02		0.02
Chlorides ( as KCl)	0.10		0.04
Chlorates ( as KClO <sub>3</sub> )	0.10		0.08
Hypochlorites	None		None
Bromates ( as KBrO <sub>3</sub> )	0.02		None
Sodium as (NaClO <sub>2</sub> )	0.20		0.02
Magnesium Salts & Calcium (as oxide)	0.20		None
Grit & Water Insoluble Material	0.02		0.01
pH of Water Solution	8.5	6.5	6.5
Assay		99.8	99.8
Average Particle Size	25	15	23 M

REMARKS

I certify that the material used on this lot meets all the requirements of the purchase order and the requirements of the specification MIL-P-217A

NAME OF COMPANY

**BARIUM AND CHEMICALS INC.**  
**Steubenville, Ohio**

NAME AND TITLE OF OFFICIAL

*Albert Phillips, Jr.*  
**Albert Phillips, Jr. - Vice President**

APPENDIX B

**SUPPLEMENT TO MBAssociates'  
RADIOMETRIC PROCEDURES (MB-R-78/32)**

**27 August 1979**

**MB-TM-79/02**

**PREPARED BY**

** MBAssociates**

**Bollinger Canyon Road, San Ramon, California 94583**

**SUPPLEMENT TO MBAssociates'  
RADIOMETRIC PROCEDURES (MB-R-78/32)**

**27 August 1979**

**MB-TM-79/02**

**PREPARED BY**

**MBA MBAssociates**

Bollinger Canyon Road, San Ramon, California 94583

## INTRODUCTION

This technical memo was written to clarify and add to, the MBA Radiometric Procedures Manual (MB-R-78/32). There are five sections in this memo, they are: a procedure for calculating the effective infrared intensity of an IR flare; a section on radiometric measurements and instrumentation; a section on radiometer calibration; a section on the computer programs used in radiometric measurements; and finally, a section on flare ejection tests which are performed to determine the velocity and set-back force of an ejected flare.

PROCEDURE FOR  
CALCULATING EFFECTIVE INFRARED  
INTENSITIES

The purpose of this booklet is to provide a quick and fairly accurate means of determining the effective radiation from an IR source 75 feet away. The following procedure is intended to be used with MBA's pyroelectric radiometers with sapphire windows and 1.7 - 2.8 and 3-5 micron passband filters.

This normalization procedure relies on graphs that have been generated by extensive computer runs. These computer programs, LOWTRAN IV and LAMDA, determine the effects of the atmosphere, the radiometer windows and filters, and the detector's relative response has on the transmission of infrared radiation.

Because the meteorological conditions at the time the measurements were taken will never exactly match the conditions for which the computer runs were made, some approximations will have to be made and, therefore, some error will exist. The maximum expected error is on the order of 1% for both bands (1.7 - 2.8 and 3.0 - 5.0 $\mu$ ). If greater accuracy is desired, then separate LOWTRAN and LAMDA runs should be made using the exact meteorological data at the time of the test.

The range of atmospheric conditions that can be used are given in Tables 1 and 2. If conditions do not fall within these ranges, then separate runs should be made. Also, if the visibility drops below 5Km, aerosol absorption becomes significant and separate runs should be made to determine complete atmospheric absorption.

PROCEDURE FOR CALCULATING EFFECTIVE RADIANT INTENSITY

STEP 1: Calculate the current calibration constant from:

$$C = \frac{C_c S_c}{S_t}$$

STEP 2: Calculate the peak intensity from  $I = CVR^2$  for both the 1.7 - 2.8 and the 3.0 - 5.0 $\mu$  passbands.

STEP 3: From the ratio of the peak intensity of the short wavelength band (1.7 - 2.8 $\mu$ ) divided by the peak of the long wavelength (3.0 - 5.0 $\mu$ ) band, determine the source temperature from graph 1.

STEP 4: Correct for temperature by multiplying each calibration constant by the temperature correction factor obtained from graphs 2 & 3.\*

STEP 5: Determine the amount of atmospheric transmission from graphs 4 & 5. Note that these graphs were generated from a LOWTRAN run which used the following meteorological data.

Source to detector distance = .0229 Km (75 ft)

Visual range = 100 Km

Atmospheric pressure = 1000 MB

Altitude = .1524 Km

Temperature = 21.11 $^{\circ}$ C

Humidity = 40%

STEP 6: Correct for the meteorological conditions at the time of the test by finding those conditions which most closely match the conditions listed in tables 1 and 2, and divide the average transmission of this run into the average transmission from the run using the conditions mentioned in Step 5.

\* It is necessary to correct for source temperature because our calibration source is 1273 $^{\circ}$ K and our flares usually burn at 2000 $^{\circ}$ K.

STEP 7: Take the number obtained in STEP 6 and divide it into the calibration constant. Decreased transmission means an increase in intensity for a given voltage.

SAMPLE CALCULATION

3.0 - 5.0 $\mu$  passband

$$C = 16.00 \text{ Watts}/(\text{SR})(\text{Volts}) (\text{feet})^2$$

$$V = .6669 \text{ Volts (peak)}$$

$$R^2 = 5625 \text{ ft}^2$$

$$I = 60,000 \text{ watts/SR (Apparent)}$$

1.7 - 2.8 $\mu$  passband

$$C = 17.00 \text{ W/SRV ft}^2$$

$$V = 1.05 \text{ V (Peak)}$$

$$R^2 = 5625 \text{ ft}^2$$

$$I = 100,000 \text{ Watts/SR (Apparent)}$$

Meteorological Conditions

Altitude = .1524 Km

Atmospheric pressure = 1000 MB

Temperature = 32.22 $^{\circ}$ C

Visibility = 100 Km

Source to Detector Distance = .0229 Km

Humidity = 80%

STEP 1: C = 16.00 (3-5 $\mu$ )  
C = 17.00 (1.7 - 2.8 $\mu$ )

STEP 2: I = (16.00)(.6669)(5625) = 60,000 W/SR (3-5 $\mu$ )  
I = (17.00)(1.05)(5625) = 100,000 W/SR (1.7 - 2.8 $\mu$ )

STEP 3: 
$$\frac{100,000 \text{ WATTS/SR}}{60,000 \text{ WATTS/SR}} = 1.6667$$

From graph #1, temperature = 1790°K

STEP 4: 
$$C = 16.00 \text{ (3-5}\mu\text{)}$$
$$T = 1790^{\circ}\text{K}$$

From graph #3, correction factor = 1.0086  
New C = 16.00 x 1.0086 = 16.1376

$$C = 17.00 \text{ (1.7 - 2.8 } \mu\text{)}$$
$$T = 1790^{\circ}\text{K}$$

From graph #2, correction factor = .970  
New C = 17.00 x .970 = 16.490

STEP 5: For 1.7 - 2.8 $\mu$  passband use graph #4  
Flare Temperature = 1790°K  
From graph #4, transmission = .8315  
For 3-5 $\mu$  passband, use graph #5  
Flare Temperature = 1790°K  
From graph #5, average transmission = .8856

STEP 6: For 1.7 - 2.8 $\mu$  passband  
From table 1, base average transmission  
= .7835. From the conditions at the time of the  
test, 32.22°C and 80% humidity, the average  
transmission obtained from table 1 is .7037.

$$\frac{.7835}{.7037} = 1.1134$$

From Step 5, average transmission = .8315 (1.7 - 2.8 $\mu$ )  
$$\frac{.8315}{1.1134} = .7468$$
  
1.1134

For 3-5 $\mu$  passband

From table 2, base average transmission  
= .8888. From the conditions at the time of the  
test, 32.22 $^{\circ}$ C, 80% humidity, the average trans-  
mission obtained from table 2 is .8488.

$$\frac{.8888}{.8488} = 1.0471$$

From step 5, average transmission = .8856 (3-5 $\mu$ )

$$\frac{.8856}{1.0471} = .8458$$

STEP 7:  $\frac{16,490}{.7468} = 22,081$  (1.7 - 2.8 $\mu$ )

$$\frac{16,1376}{.8458} = 19,0797$$
 (3-5 $\mu$ )

STEP 8. Calculate effective flare intensities

For 1.7 - 2.8 $\mu$  passband

$$V = 1.05V$$

$$R^2 = 5625 \text{ ft}^2$$

$$C \text{ eff} = 22,081$$

$$I \text{ eff} = (22,081)(5625)(1.05) = 130,416 \text{ WATTS/SR}$$

For 3-5 $\mu$  passband

$$V = .6667 \text{ V}$$

$$R^2 = 5625 \text{ ft}^2$$

$$C \text{ eff} = 19,0797$$

$$I \text{ eff} = (19,0797)(5625)(.6667) = 71,500 \text{ WATTS/SR}$$

GRAPH #1

# RATIO OF SHORT TO LONG WAVELENGTH INTENSITY VS TEMPERATURE

1.7 - 2.8  $\mu$   
3.0 - 5.0  $\mu$

461510  
K-Σ  
10 X 10 TO THE CENTIMETER  
KEUFEL S. SNER CO. MADE IN U.S.A.

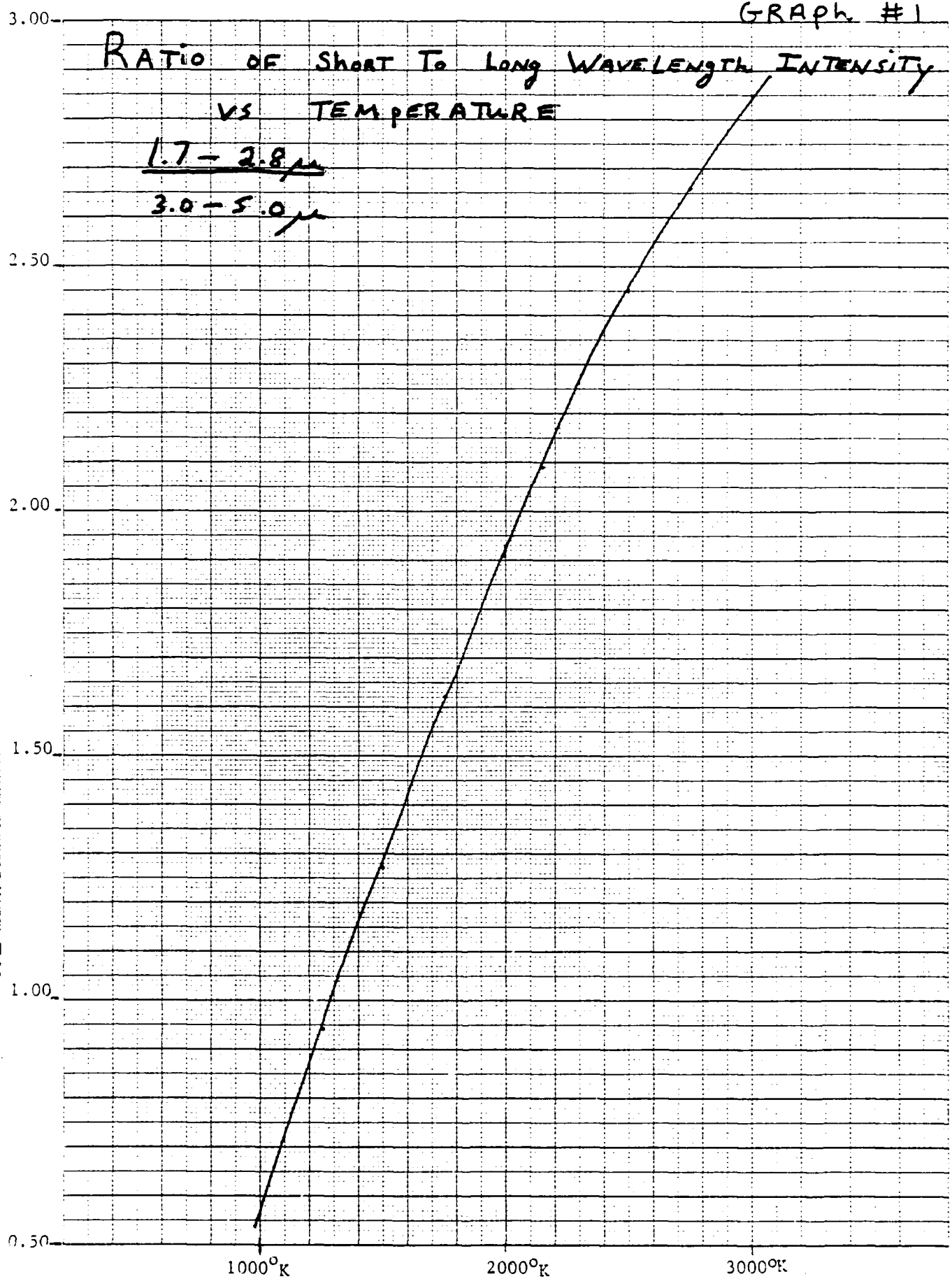

GRAPH #2

# TEMPERATURE CORRECTION FACTOR VS TEMPERATURE

PASS BAND = 1.7 - 2.8  $\mu$

461510

K $\times$   
IN X 10 TO THE CENTIMETER IN S. P. M.  
MULTIPLY BY 100 TO GET IN INCHES

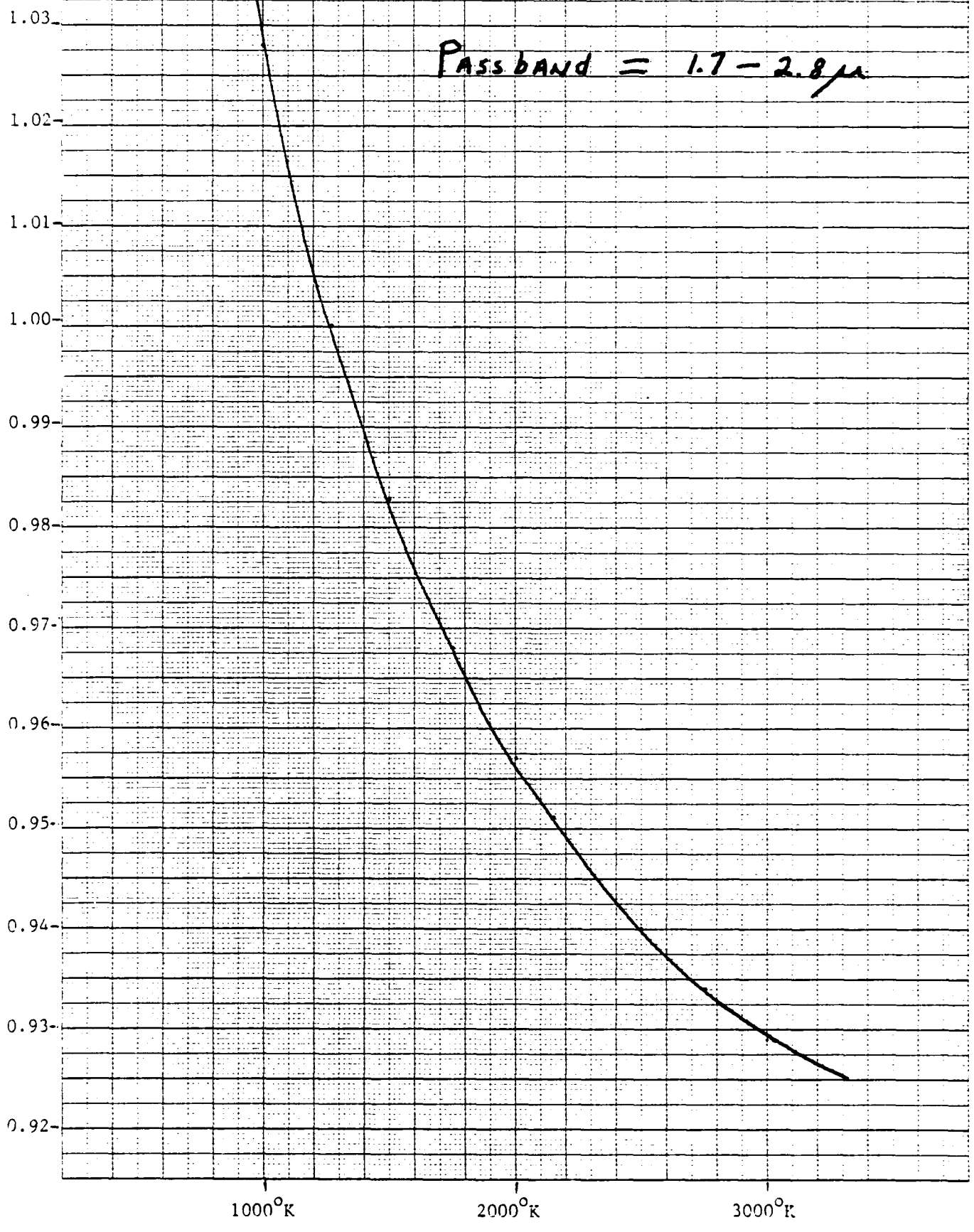

GRAPH #3

# TEMPERATURE CORRECTION FACTOR VS TEMPERATURE

PASSBAND = 3-5 $\mu$

461510

K-Σ  
10 X TO THE CENTIMETER  
MURRAY & LESER, INC. MADE IN U.S.A.

1.02  
1.01  
1.00  
0.99

1000°K

2000°K

3000°K

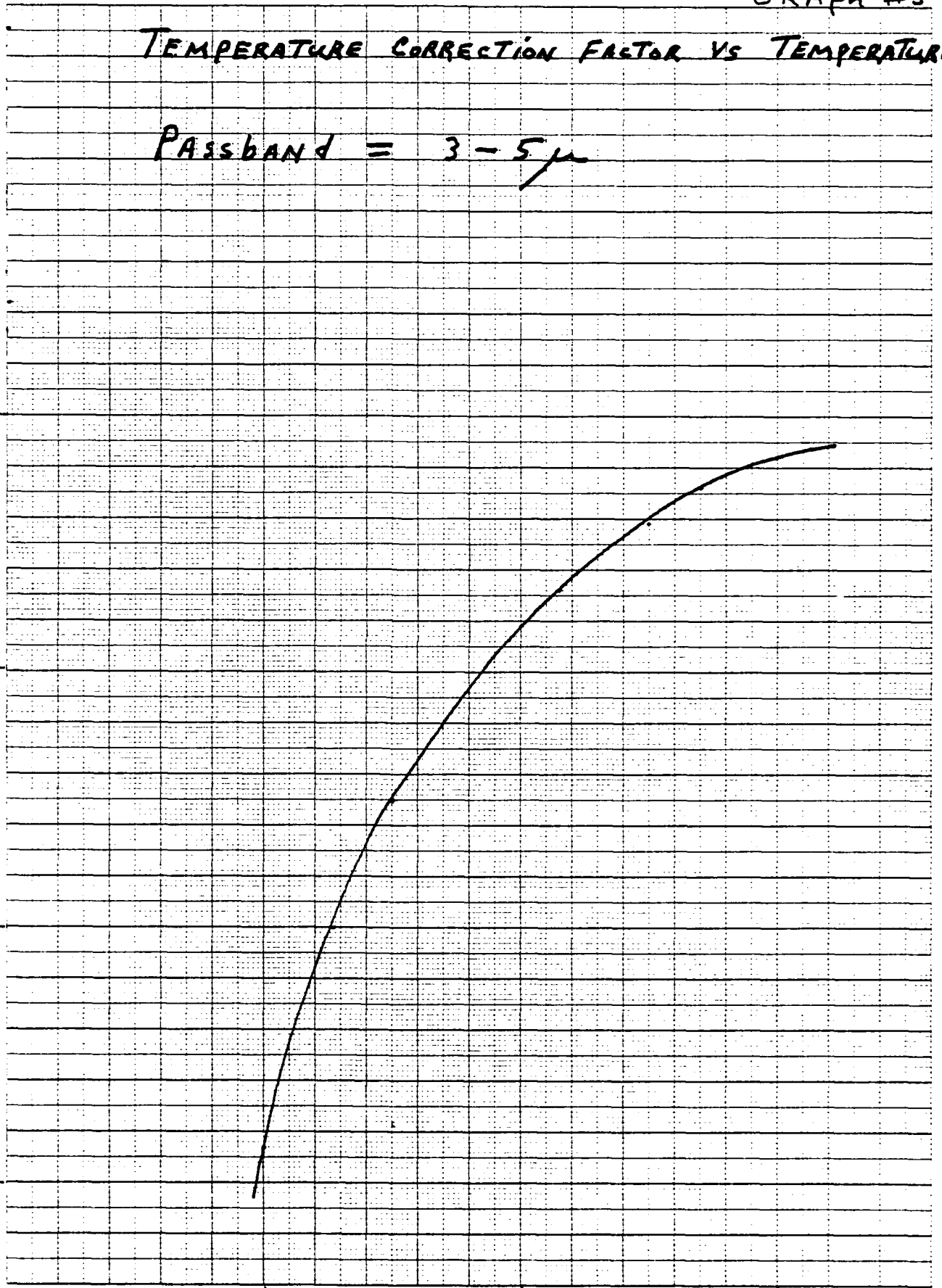

# ATMOSPHERIC TRANSMISSION VS TEMPERATURE

PASSBAND = 1.7-2.8  $\mu$

461510

$K \cdot \Sigma$  10 X 10 TO THE CENTIMETER IN A COLUMN  
REDFIELD & LESSER CO. MADE IN U.S.A.

0.86-  
0.85-  
0.84-  
0.83-  
0.82-  
0.81-  
0.80-  
0.79-  
0.78-  
0.77-  
0.76-  
0.75-

1000°K

2000°K

3000°K

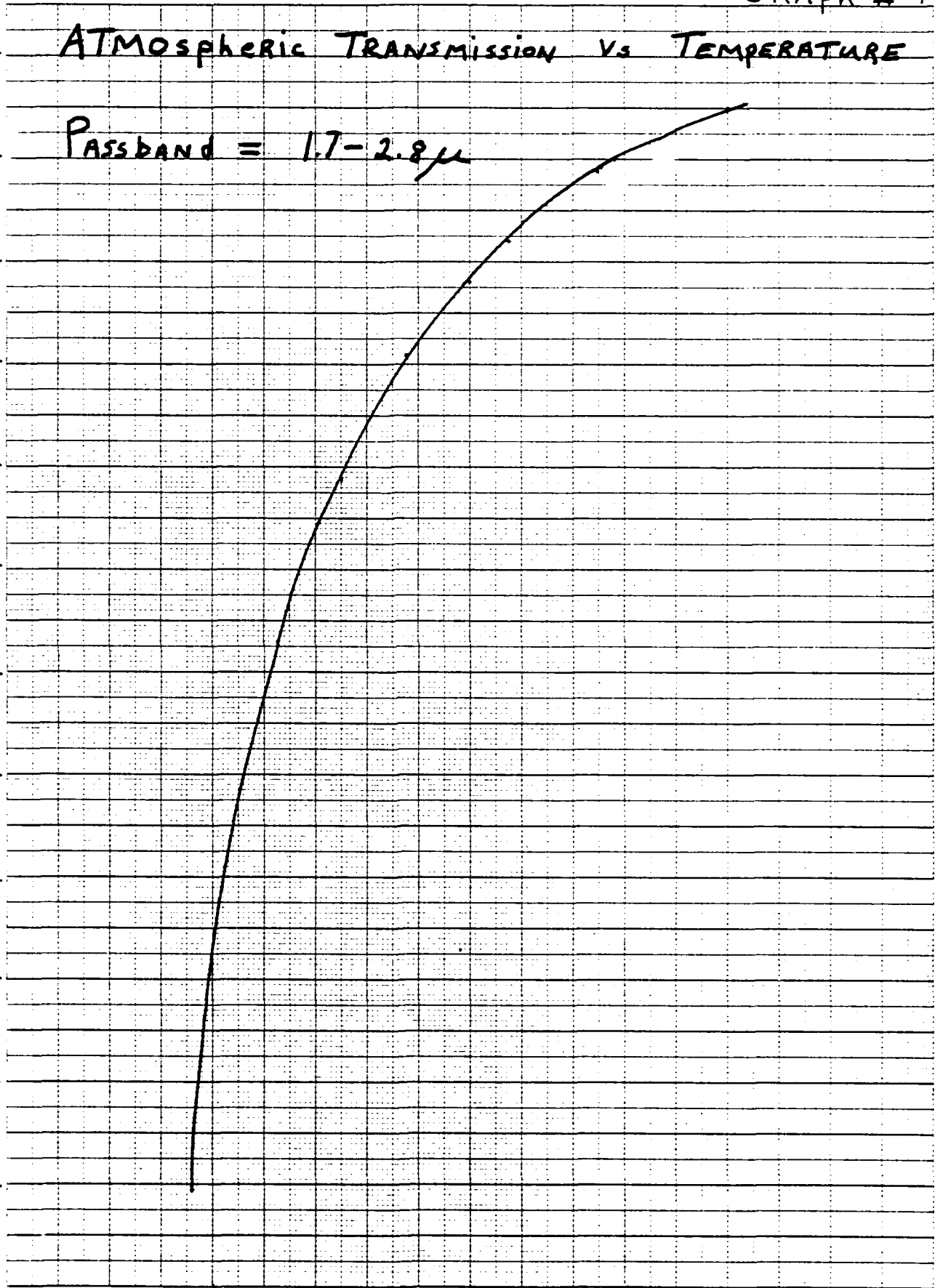

GRAPH #5

# ATMOSPHERIC TRANSMISSION VS TEMPERATURE

PASSBAND = 3.0 - 5.0  $\mu$

461510  
0.890

0.885

K<sub>2</sub>S  
10 X 10 TO THE CENTIMETER  
ALUMINUM  
MADE IN U.S.A.

0.880

0.875

1000°K

2000°K

3000°K

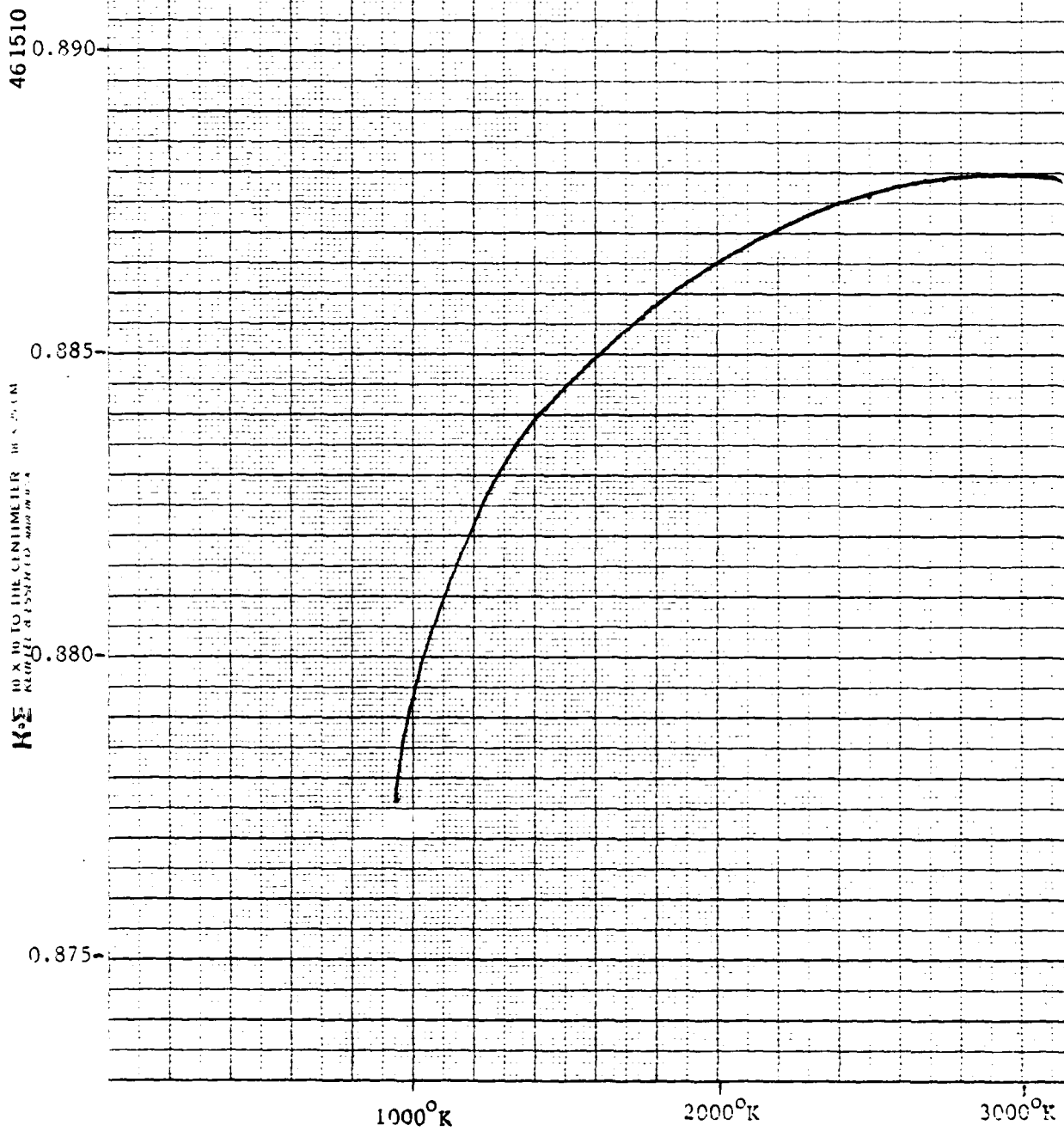

1.7 - 2.8μ TABLE 1

ALTITUDE	PRESSURE	TEMPERATURE	HUMIDITY	VISIBILITY	PATH L	TRANS (AVE)
.1524 Km	1000 MB	10.0°C	40%	100 Km	.0229 Km	.8219
.1524	1000	10.0	60%	100	.0229	.7984
.1524	1000	10.0	80%	100	.0229	.7811
.1524	1000	15.56	40%	100	.0229	.8026
.1524	1000	15.56	60%	100	.0229	.7783
.1524	1000	15.56	80%	100	.0229	.7607
.1524	1000	21.11	40%	100	.0229	.7835
.1524	1000	21.11	60%	100	.0229	.7586
.1524	1000	21.11	80%	100	.0229	.7409
.1524	1000	26.67	40%	100	.0229	.7648
.1524	1000	26.67	60%	100	.0229	.7397
.1524	1000	26.67	80%	100	.0229	.7220
.1524	1000	32.22	40%	100	.0229	.7466
.1524	1000	32.22	60%	100	.0229	.7216
.1524	1000	32.22	80%	100	.0229	.7037
.1524	1000	37.78	40%	100	.0229	.7292
.1524	1000	37.78	60%	100	.0229	.7041
.1524	1000	37.78	80%	100	.0229	.6860

3-5 $\mu$  TABLE 2

ALTITUDE	PRESSURE	TEMPERATURE	HUMIDITY	VISIBILITY	PATH L	TRANS (AVE)
.1524 Km	1000 MB	10.0 <sup>o</sup> C	40%	100 Km	.0229 Km	.9007
.1524	1000	10.0	60%	100	.0229	.8933
.1524	1000	10.0	80%	100	.0229	.8871
.1524	1000	15.56	40%	100	.0229	.8951
.1524	1000	15.56	60%	100	.0229	.8864
.1524	1000	15.56	80%	100	.0229	.8791
.1524	1000	21.11	40%	100	.0229	.8888
.1524	1000	21.11	60%	100	.0229	.8786
.1524	1000	21.11	80%	100	.0229	.8701
.1524	1000	26.67	40%	100	.0229	.8817
.1524	1000	26.67	60%	100	.0229	.8699
.1524	1000	26.67	80%	100	.0229	.8601
.1524	1000	32.22	40%	100	.0229	.8737
.1524	1000	32.22	60%	100	.0229	.8603
.1524	1000	32.22	80%	100	.0229	.8488
.1524	1000	37.78	40%	100	.0229	.8651
.1524	1000	37.78	60%	100	.0229	.8995
.1524	1000	37.78	80%	100	.0229	.8365

LAMDA RUN WITHOUT Tw, Tf, Ta, Vd

Passband = 1.7 - 2.8 $\mu$

For Filter 1.7 - 2.8 $\mu$

<u>Temp °K</u>	<u>TOTAL IN BAND WATTS/SR</u>
1000	.36074
1273	1.4340
1500	3.1466
1750	5.9885
2000	9.8083
2150	12.535
2500	20.014
2750	26.181
3000	32.923

LAMDA RUN WITH Tf, Tw, Vd

WITHOUT Ta

Passband = 1.50 - 3.05 $\mu$

For filter 1.7 - 2.8 $\mu$

<u>Temp °K</u>	<u>TOTAL IN BAND WATTS/SR</u>
1000	.25819
1272	1.0550
1500	2.3552
1750	4.5502
2000	7.5425
2150	9.6978
2500	15.664
2750	20.628
3000	26.084

LAMDA RUN WITH Ta, Tw, Tf, Vd

Filter = 1.7 - 2.8

Passband = 1.50 - 3.05 $\mu$

<u>Temp °K</u>	<u>TOTAL IN BAND WATTS/SR</u>
1000	.19921
1273	.84716
1500	1.9284
1750	3.7784
2000	6.3237
2150	8.1666
2500	13.293
2750	17.575
3000	22.295

LAMDA RUN WITHOUT Ta, Tf, Tw, Vd

Passband = 3-5 $\mu$

<u>Temp °K</u>	<u>TOTAL IN BAND WATTS/SR</u>
1000	.65146
1273	1.5162
1500	2.4693
1750	3.7073
2000	5.0951
2150	5.9840
2500	8.1830
2750	9.8367
3000	11.543

LAMDA RUN WITH Tf, Tw, Vd

Without Ta

Passband = 2.85 - 5.20 $\mu$

For Filter 3.0 - 5.0 $\mu$

<u>Temp °K</u>	<u>TOTAL IN BAND WATTS/SR</u>
1000	.44292
1273	1.0220
1500	1.6562
1750	2.4769
2000	3.3944
2150	3.9810
2500	5.4301
2750	6.5184
3000	7.6403

LAMDA RUN WITH Tf, Tw, Vd, Ta

Passband = 2.85 - 5.20 $\mu$

For Filter 3.0 - 5.0 $\mu$

<u>Temp °K</u>	<u>TOTAL IN BAND WATTS/SR</u>
1000	.38946
1273	.90206
1500	1.4647
1750	2.1935
2000	3.0089
2150	3.5305
2500	4.8195
2750	5.7879
3000	6.7863

## RADIOMETRIC MEASUREMENTS

### Equipment

Currently, MBA uses three Molection Pyroelectric radiometers to measure the infrared radiation produced by our flares. The radiometer system is composed of a probe assembly, control assembly, amplification system and a black body calibration source.

The probe assembly is encased inside an environmental housing. There is a small port in the housing to allow the influx of radiation to reach the probe. This port is actually a sapphire window which is transparent to IR radiation. The housing and window are used to protect the actual probe assembly from hostile environments.

The probe itself is made up of a pyroelectric transducer which emits a voltage (electrons) proportional to the incident radiation. The assembly also includes a low noise amplifier, mechanical chopper and a photo-isolator frequency reference. Attached externally to the probe is an infrared filter allowing only the infrared radiation of interest to reach the detector.

The radiometer control assembly contains amplifiers and other internal electronics to convert the incoming AC voltage to DC while also shaping and filtering the signal. The control panel contains various buttons and switches which are described below.

### Radiometer Front Panel Functions

#### Power Switches

This is the red push button switch at the lower left of the unit which applies power to the system when pushed in.

#### Watts --- Watts/cm<sup>2</sup> Switch

Watts --- Watts/cm<sup>2</sup> Switch is located in the upper right hand side of the unit and is used to normalize the gain of the system to compensate for the area of the detector. The Watts position is normally

used for small beams (lasers). The Watts/cm<sup>2</sup> is used for sources where the radiation fills an area equal to or larger than the detector. For all flare and black body measurements, the switch should be placed in the Watts/cm<sup>2</sup> position.

#### Offset Control

The main purpose of this switch is to compensate for background radiation when the radiometer is on a sensitive scale. Because we use a relatively insensitive scale, the switch should be turned completely counter-clockwise in order to provide maximum range.

#### Range Switch

The row of black push buttons near the bottom of the control panel are used to change the gain of the system. The buttons are push-on and push-off and are also interlocking so that when a new range button is pushed, the old one automatically returns to the off position. There are seven range buttons, each divided into three categories; milliwatts (MW), microwatts ( $\mu$ w) and nanowatts (nw). This stands for  $1 \times 10^{-3}$  WATTS,  $1 \times 10^{-6}$  WATTS, and  $1 \times 10^{-9}$  WATTS respectively.

For measuring flares only the milliwatt scale will be used. This scale is, in turn, divided into three subscales; 1 milliwatt (MW), 10 MW, and 100 MW. Because all calibrations and calculations are computed for the 10 MW scale, this scale is the most convenient to use. However, these other two scales can be used but will have to be converted to the 10 MW upon reduction of the data. For example, if one was using the 1 MW scale, the radiometer would be ten times more sensitive than when set on the 10 MW scale, therefore, when calculating the intensity  $CVR^2$  would be divided by 10 to give the correct intensity relative to the 10 MW scale. On the other hand, if the range was on 100 MW, the radiometer is 10 times less sensitive than when on the 10MW scale and therefore  $CVR^2$  would have to be multiplied by 10 in order to keep things relative to the 10 MW scale.

### Amplifiers

The amplifiers serve two purposes. One function is to amplify the signal from the radiometer to produce a measurable trace on the oscillograph. The other function is to produce a 1 volt calibration mark on the o-graph trace.

The amplifiers are located at the bottom of the rack in the radiometer control box. There are four amplifiers but only three are used. Each amplifier has five knobs which are explained below.

### Range & Multiplier Knobs

These two knobs control the gain (how much the signal is amplified). The range switch which goes from 1 to 2 to 3 to 5 is multiplied by the multiplier knob which can be placed on X.01, X.1, X1, X10. For example, if the range switch is on 2 and the multiplier is on X1.0 then the gain is 2. If the multiplier switch is then placed on X10, the gain will be 20 which will cause a deflection 10 times greater than when the multiplier was on X1.0.

For flares such as the MJU-10 and MFCD at a source to detector distance of 75 feet, a good o-graph deflection is produced with a gain of 5 (range on 5, multiplier on X1) and a milliwatt setting of 10.

### Offset Knob

The offset knob is used to zero out the galvo that is in series with the radiometer. The offset switch can only move the galvo an inch or so, therefore, whenever it is desired to move the trace further, the galvo itself will have to be moved manually. (See oscillograph manual).

### Mode Knob

This knob is used to calibrate the oscillograph trace. There are five different positions for this knob: Signal (sig), ground (gnd), .5 volts ( $\frac{1}{2}$  V), 1 volt (1V), and 2 volts (2V). Whenever a source is being measured the knob must be in the signal position. When calibrating the trace, the knob is switched from sig to gnd to  $\frac{1}{2}$ V to 1V and then

back to sig. By measuring the distance between ground and 1 Volt it can be determined how many inches per volt deflection.

#### BW Hertz

This switch controls the band width and should always be placed on WB (wide band) for flare and black body measurements.

#### Black Body

The Infrared Radiation Reference Source (Black Body) is used as a standard against which other laboratory measuring devices (radiometers) can be compared.

The Black Body is very easy to operate. First one plugs in the control box which automatically starts the fan inside the Black Body. Next, the switch located on the front of the temperature controller is placed in the "on" position. Finally, the desired temperature is set by turning the knob on the left. All calibrations are done at 1000°C so this is where the selector should be set. It takes about 90 minutes for the Black Body to come up to this temperature.

Note: Before the Black Body is turned off its internal temperature must be less than 200°C. Therefore, after use, the selector should be turned down to 50°C and the system allowed to cool until that time in which the temperature drops below 200°C. The way temperature is determined is to move the temperature selection switch while watching the volt meter on the left, when the voltmeter deflects the Black Body is at that temperature indicated on the scale. Once the Black Body is below 200°C, the controller can be turned off and unplugged to stop the fan.

#### Oscillograph

The o-graph is used to keep a running time versus voltage trace of the flare burn. The input jacks are located in the back, on the outside, of the oscillograph. There are eighteen input jacks in the back, but there are only about eight operational galvos. All necessary information regarding the operation and maintenance of the oscillograph

can be obtained from the Consolidated Electrodynamics Datograph Operation  
and Maintenance Manual.

## RADIOMETER CALIBRATION

The radiometers are calibrated periodically according to the procedure given below:

- STEP 1: Turn both the black body and the radiometers on at least 1-½ hours before calibration. Set the black body for 1000°C and make sure it is at this temperature before calibrating.
- STEP 2: Determine what milliwatt setting the radiometers are to be used. If they are to be used with the 10 milliwatt scale, then calibrate on the 10 milliwatt scale. Do not change milliwatt scale settings during the calibration procedure.
- STEP 3: Turn on the oscillograph and adjust the galvo, connected to the radiometer to be calibrated, to the right side of the light sensitive paper.
- STEP 4: Place the radiometer in the standardization fixture against the stops.
- STEP 6: Obtain an opaque sheet to be placed between source and radiometer.
- STEP 7: Move the black body to three inches of the radiometer face. The distance between the radiometer face and the black body face is three inches, any two points can be used but these same points must be used throughout the calibration.
- STEP 8: Align the axes of the radiometer and the source so that the radiometer face and black body face are parallel and the black body aperture is in the center of the field of view of the radiometer.

STEP 9: Remove the sheet in front of the radiometer and watch the digital display on the radiometer panel. If the digital display holds at -1, then the system is saturated. Try increasing the offset on the radiometer panel (not the amplifier) to unsaturate the system. If this does not work, the black body will have to be moved further back.

Note: As long as the system is on the 10 MW setting, this will not be a problem; however, it will be a problem on the 1 MW scale.

STEP 10: Run an oscillograph/amplifier calibration to determine how many inches/volt.

STEP 11: Measure and record the distance in inches between the faces of the radiometer and the black body.

STEP 12: Start the o-graph, remove the sheet in front of the radiometer and record the output.

STEP 13: Move the black body so that the distance between faces is now four inches and repeat steps 11 and 12.

STEP 14: Move to 5 inches and repeat steps 11 and 12.

STEP 15: Now place the black body in its standardization fixture against the stops and repeat steps 11 and 12.

STEP 16: Keep moving the black body back at one inch intervals repeating steps 11 and 12 at each interval.

STEP 17: After measuring and recording at 12 inches between faces, stop.

STEP 18: Repeat steps 1 through 17 for the other radiometers.

#### DATA REDUCTION

STEP 1: From the oscillograph traces from the individual radiometers, abstract the oscillograph/amplifier calibration in inches/volts and the deflection in inches from each of black body to radiometer distances recorded.

STEP 2: Input all the necessary data into the computer program RADCAL. A detailed description of the input procedure is given in the computer section of this booklet.

STEP 3: After running RADCAL, check the individual sigmas for each radiometer. The sigma is how well the data points fit a straight line. Sigma = 1.000 is a perfectly straight line. If sigma is less than .9990, the computer will print "sigma indicates line is not linear." If this should happen, the points should be plotted (X & Y's) and any outlying points should be discarded. The program is then run again until an acceptable sigma is obtained.

STEP 4: From the computer printout, record the calibration constant and the voltage at the standard position. The standard position was that position where both the radiometer and the black body were in their respective standardization fixtures up against the stops. This distance is right around 7.1 inches.

## COMPUTER PROGRAMS USED IN RADIOMETRY

### Program LOWTRAN

Because certain molecules absorb infrared radiation and because the amount of absorption is different for different meteorological conditions, it is necessary to normalize the radiometric data. The way in which data is normalized for atmospheric conditions is through the computer program LOWTRAN. This program, developed by the Air Force, determines the amount of infrared radiation absorbed by different molecules at different wavelengths and the total amount of transmitted infrared radiation over a specific passband depending on the meteorological conditions of the time.

A condition on how to input meteorological data into this program is given in the MBA Radiometric Procedures, MB-R-78/32, Rev. 1, Page 24.

The output of LOWTRAN is easy to read. First, the meteorological data inputted is printed, followed by individual total transmissions and transmissions of various molecules over the wavelengths of interest. Finally, the total transmission over the band of interest is given.

### Program LAMDA

This computer program was developed to determine the maximum amount of intensity that could be received from an infrared source and the effect that windows, filters, detectors and the atmosphere have on the apparent intensity of this source. In other words, if we have a theoretical black body source at a specific temperature, there exists a maximum possible intensity. However, because filters, windows, and the atmosphere are not 100% transparent to infrared radiation and because detectors are wavelength dependent\*, we will never detect this absolute maximum intensity. LAMDA is used to determine the effective intensity of an IR source by taking in account the percent transmission of windows, filters and atmosphere along with the response of the detector.

\*  

---

MBA radiometers have pyroelectric detectors and for all practical purposes these detectors can be considered flat with respect to wavelength, i.e. detector sensitivity is uniform at all wavelengths.

Because effective transmission changes with source temperature, as the result of changing spectral curve and the different transmission qualities of windows, filters and the atmosphere at different wavelengths, Lamda is run over a number of source temperatures.

The method for inputing data for this program is given in the MBA Radiometric Procedures, pages 25-27.

The output of Lamda gives the incremented passband, source temperature, area of the source, the emissivity of the source and the total intensity in band.

### Program RADCAL

This program is used to calculate the calibration constant for the different radiometers. This program takes data obtained from the manual calibration procedure and computes the constant and how well the data fits a straight line via a linear regression routine.

The data it takes is distance from black body to radiometer in inches (Y), deflection of oscillograph galvo in inches (DEF), radiometer range in milliwatts (MW), the oscillograph/amplifier calibration in inches/volt (CALB), the number of points measured (N), and the radiometer being calibrated (RAD). A detailed procedure for inputting the data is given below.

- CARD 1: Input the number of data points, i.e., how many Y's in I3.
- CARD 2: Input the amplifier/oscillograph calibration (inches/volt) in F 10.2.
- CARD 3: Input the milliwatt scale setting in I3.
- CARD 4,5,6: Input the deflection of the oscillograph galvo starting at either one end or the other and proceed progressively. Input 5 data points per card and always use 3 cards even if the last card is all zeros. The format is 5F 10.4.
- CARD 7,8,9: Input the distance from black body to radiometer making sure that the starting point and direction are the same as for the deflection input above. The format is 5F 10.4.
- CARD 10: Input the radiometer that is being calibrated in F 10.0. For example, if radiometer 134 is being calibrated, punch 134. in any of the first ten columns.
- CARD 11: If another set of data (new radiometer) is to be inputed, punch a 1 in I3 and punch new cards 1-11. If there is not going to be another set of data, leave this card blank.

The output of RADCAL is a regurgitation of the input data along with a column of the calculated volts, X, which is  $1/\sqrt{\text{volts}}$  and is used for the linear regression routine, the calibration constant and the sigma of the data, i.e., how well the data fits a straight line. A perfectly straight line would have a sigma of 1.000. The more the data deviates from a straight line, the more sigma becomes less than one. If sigma is less than .9990, the data points, the X and Y values, should be plotted and any anomalies should be discarded. After discarding all obvious anomalies, the program should run again to obtain the correct calibration constant.

## EJECTION TESTS

Ejection tests are performed to determine the velocity and set-back force of an ejected flare.

### Equipment Needed

- 1) Ejection test fixture
- 2) Oscillograph
- 3) BLH Load Cell
- 4) CEC Transducer signal conditioner and amplifier case assembly
- 5) 0-10V D.C. power supply
- 6) Leeds potentiometer
- 7) Calibrated digital voltmeter

### Flare Velocity Measurements

Velocity measurements are made by placing 3 break leads a foot apart from each other in the path of the flare and recording the time it takes between each breakage. This is done by placing a 3 to 4 volt potential difference across the system. The oscillograph is used to record the time and is in series with the system. Between each of the break leads there is a resistor which produces a potential drop which is recorded by the oscillograph after each break lead is broken. Because we know the speed of the o-graph via the calibrated timing mark and because we know the distance between break leads, the velocity can be determined. The ejection test set-up is shown in Figure 1.

Once the system described in schematic 1 is set-up, adjust the galvo and the D.C. power supply so that the galvo is on the far left hand side of the trace when no break leads are in the fixture and then on the far right hand side of the fixture when all of the break leads are in place.

Next, set the timing light on the o-graph to 100 pulses/second. For the test, the o-graph chart speed should be 64 inches/second.

After the flare is ejected, there will be two steps in the o-graph trace. When the flare breaks the first lead there will be a decrease in voltage. This new voltage will stay constant (first step) until the next lead is broken. When the next lead is broken, there will be another voltage drop which will stay constant (second step) until the final lead is broken.

#### Sample Calculation

Timing light = 100 pulses/second

Chart speed = 64 inches/second

Length of  
step = 1.6 pulses

$$\frac{1.60 \text{ pulses}}{100 \text{ pulses/second}} = .01600 \text{ seconds}$$

$$\frac{1 \text{ foot}}{.01600 \text{ seconds}} = 62.500 \text{ ft/sec}$$

#### Load Measurement

Load measurements are taken to determine the set-back force the flare pellet will exert on the aircraft it will eventually protect.

The load cell is a strain-gage pressure transducer which produces an electrical signal proportional to the pressure exerted upon it.

The load cell that is used is a BLH, C2M1 type. Its capacity is 5000 pounds and its output is 2 millivolts/volt at 100% capacity.

Since we use a 10 volt excitation voltage, we would expect  $10 \text{ volts} \times \frac{2 \text{ MV}}{\text{VOLT}} = 20 \text{ MV}$  at 100% capacity or 5000 pounds of pressure. However, the set-back force of the flare should be no greater than 1000 pounds and therefore the maximum unamplified signal we should receive is 4 millivolts. Because this signal is too small to be recorded by the oscillograph, it is amplified by the CEC transducer signal conditioner. The wiring diagram for set-back force measurement is shown in Figure 1.

### Amplifier Gain Setting and Calibration

For this part of the procedure, the load cell is replaced with the Leeds Potentiometer. The Leeds Potentiometer is a D.C. millivolt power supply and is used to simulate the output voltage expected from the load cell. Because the potentiometer is out of calibration, a calibrated digital voltmeter can be used to find, set, and record the desired millivolt output.

#### STEP 1:

Attach the white wire from the CEC conditioner to the plus output of the potentiometer and the green wire to the negative output,

#### STEP 2:

Attach the positive and negative leads of the digital voltmeter to the positive and negative output of the potentiometer.

#### STEP 3:

Make sure the gain and offset switches of the signal conditioner are set on OPR and ZERO respectively.

#### STEP 4:

Set the potentiometer control knob on EMF output.

#### STEP 5:

Push down the galvo button and adjust the millivolt output knobs until 5.00 MV is displayed on the digital voltmeter.

#### STEP 6:

Adjust the galvo and gain and multiplier switches of the amplifier so that the zero and maximum deflection of galvo (as the result of 5 MV which would result from a set-back force of 1250 pounds) stays on scale.

STEP 7:

Once the galvo has been adjusted and the gain and multiplier switches have been set, record the galvo deflection with potentiometer output of 5 MV, 4 MV, 3 MV, 2 MV, 1 MV and 0 MV. This will provide the oscillograph amplifier calibration in inches/millivolt.

STEP 8:

Attach the load cell to the transducer/amplification system as shown in schematic 1.

After the flare is ejected, there will be a hump or peak produced by the load cell galvo. The peak height of the hump will be indicative of the set-back force.

Sample Load Calculation

$$\left( \frac{2 \text{ millivolts}}{1 \text{ volt excitation}} \right) (10 \text{ volts excitation}) = 20 \text{ millivolts}$$

This means at 100% load cell capacity or 5000 pounds there will be a 20 millivolt output signal.

If the amplifier/oscillograph calibration, as determined in step 7, is 1 inch/millivolt, and if the peak deflection produced by the ejected flare is 4 inches, then set set-back force is:

$$\frac{4 \text{ inches}}{1 \text{ inch/millivolt}} = 4 \text{ millivolts (MV)}$$

$$\frac{20 \text{ MV}}{5000 \text{ lbs}} = \frac{4 \text{ MV}}{X \text{ lbs}}$$

$$X = 1000 \text{ pounds} = \text{set-back force}$$

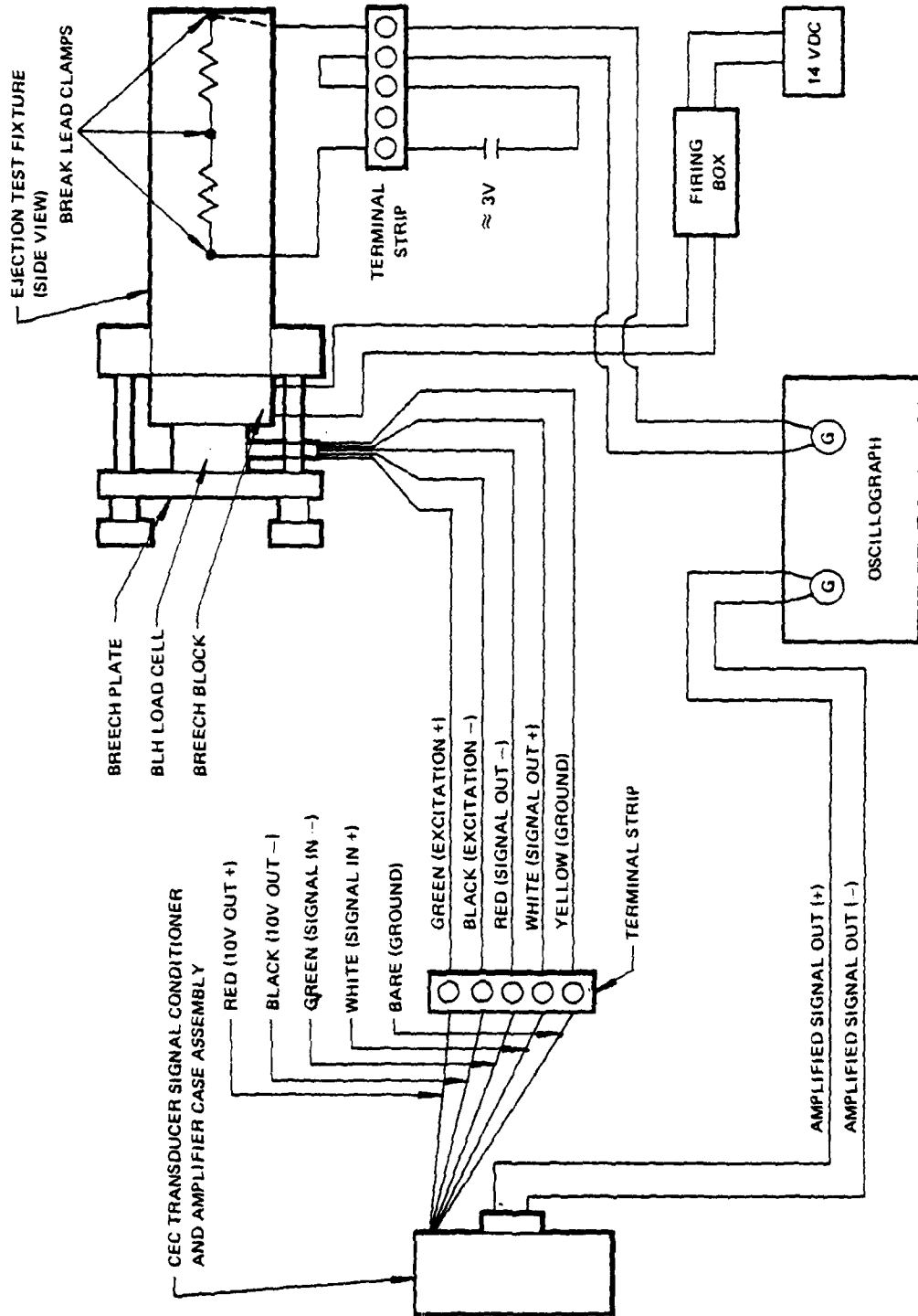

SCHEMATIC OF EJECTION TEST SET-UP

FIGURE 1

