

AD-A085 837

AIR FORCE PACKAGING EVALUATION AGENCY WRIGHT-PATTERSON—ETC F/8 13/4  
EVALUATION OF THE F100-PW-100/F100-PW-200 CORE ENGINE MODULE CO—ETC(U)  
APR 80 J T STEIGER  
PTPO-80-10

UNCLASSIFIED

NL

1 of 1  
AD-A  
760-827



END

DATE

FILMED

8-80

DTIC

APPROVED FOR PUBLIC RELEASE  
DISTRIBUTION UNLIMITED

PTPD REPORT NO. 80-10  
AFPEA PROJECT NO. 79-P7-73

**LEVEL II**

12

ADA 085837

10  
JAMES T. STEIGER  
MECHANICAL ENGINEER

12) 19

Autovon 787-3362  
Commercial (513) 257-3362

14) PTPD-80-10

DTIC  
ELECT  
JUN 20 1980  
S D E

6  
EVALUATION OF THE F100-PW-100/F100-PW-200  
CORE ENGINE MODULE CONTAINER

HQ AFALD/PTP  
AIR FORCE PACKAGING EVALUATION AGENCY  
Wright-Patterson AFB OH 45433

11 Apr 80

DDC FILE COPY

80 6 19 070 409579

**NOTICE**

When government drawings, specifications, or other data are used for any purpose other than in connection with a definitely related government procurement operation, the United States Government thereby incurs no responsibility whatsoever; and the fact that the government may have formulated, furnished, or in any way supplied the said drawings, specifications, or other data, is not to be regarded by implication or otherwise as in any manner licensing the holder or any other person or corporation, or conveying any rights or permission to manufacture, use, or sell any patented invention that may in any way be related thereto. This report is not to be used in whole or in part for advertising or sales purposes.

**ABSTRACT**

This test was performed as requested by AFALD/PTPP and the F-15 SPO to determine if the new fiberglass-reinforced plastic (FRP) container can qualify as a shipping and storage container for the F100-PW-100/F100-PW-200 Core Engine Module. One prototype FRP container was tested by the Air Force Packaging Evaluation Agency.

**PREPARED BY:**

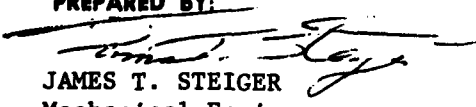
  
JAMES T. STEIGER  
Mechanical Engineer

**REVIEWED BY:**

  
RALPH ZYND  
Chief, Design Division

**PUBLICATION DATE:**

20 MAY 1980

**APPROVED BY:**

  
JACK E. THOMPSON  
Director, Air Force Packaging  
Evaluation Agency

## TABLE OF CONTENTS

	PAGE
ABSTRACT .....	1
TABLE OF CONTENTS .....	11
INTRODUCTION .....	1
PURPOSE .....	1
BACKGROUND .....	1
TEST SPECIMEN .....	1
CONTAINER .....	1
SUSPENSION SYSTEM .....	1
TEST LOAD .....	1
TEST EQUIPMENT .....	1
INSTRUMENTATION AND DATA RECORDING .....	1
TEST APPARATUS .....	1
TEST PROCEDURES .....	2
TEST RESULTS .....	3
RECOMMENDATIONS .....	7
ILLUSTRATIONS	
FIGURE 1. CONTAINER TEST PLAN .....	8
FIGURE 2. FRP CONTAINER .....	10
FIGURE 3. SUSPENSION SYSTEM .....	11
FIGURE 4. SIMULATED CORE MODULE MOUNTED IN FRP CONTAINER .....	11
FIGURE 5. DIAGRAM OF ACCELEROMETER LOCATIONS ON CORE ENGINE MODULE .....	12
FIGURE 6. SUPERIMPOSED LOAD .....	13
FIGURE 7. VIBRATION TABLE WITH CONTAINER FASTENED DOWN .....	14

TABLE OF CONTENTS (CONT'D)

FIGURE 8. BROKEN SHEAR MOUNT ..... 15

Accession For	
NTIS GRA&I	<input checked="" type="checkbox"/>
DDC TAB	<input type="checkbox"/>
Unannounced	<input type="checkbox"/>
Justification	<input type="checkbox"/>
By _____	
Distribution/	
Availability Codes	
Dist	Avail and/or special
A	

## INTRODUCTION

**PURPOSE:** These tests were performed to determine acceptance or rejection of the first article fiberglass-reinforced plastic (FRP) F100-PW-100/F100-PW-200 core engine module containers (see Figure 1 for Container Test Plan).

**BACKGROUND:** Currently the F100-PW-100/F100-PW-200 core engine module is being shipped and stored in metal MIL-C-5584 containers. A contract was awarded in August 1979 for the design and fabrication of a first article FRP core engine module container. The FRP container is lighter in weight than the MIL-C-5584 container and is projected to have a lower Life-Cycle-Cost.

## TEST SPECIMEN

**CONTAINER:** This is a fiberglass reinforced plastic container for shipping and storage of one F100-PW-100/F100-PW-200 core engine module. External dimensions of this container are approximately 100 inches in length by 62 inches wide by 63 inches high. The weight of the container shell is 693 pounds. The container was manufactured by Plastics Research Corporation under Contract No. F33601-79-C0164 (see Figure 2).

**SUSPENSION SYSTEM:** The container was fitted with an elastomeric shear mounted suspension system that was removed from the current metal F100-PW-100/F100-PW-200 core engine module container (see Figure 3).

**TEST LOAD:** A simulated core engine module was fabricated to Pratt & Whitney Aircraft Drawing L-94171 (see Figure 4). The weight of the simulated core engine module is 1029 lbs (see Figures 3 & 4).

## TEST EQUIPMENT

**INSTRUMENTATION AND DATA RECORDING:** Accelerometers on the test load were used for shock and vibration information (see Figure 5 for location and orientation of accelerometer). The transducers were Consolidated Electrodynamics Corporation's Type 4-202 Strain Gage Accelerometer. Each accelerometer was matched to a Sensotec Inc. Strain Gage Amplifier. The signal was then printed out on a Bell & Howell Datagraph 5-134 Oscillograph using Galvanometer Type 7-363. A water manometer graduated in tenths of an inch was used for the Pneumatic Pressure Tests.

## TEST APPARATUS

**LOW TEMPERATURE CHAMBER:** Manufactured by Tenney Engineering Inc., the chamber operates between  $-65^{\circ} \pm 2^{\circ}\text{F}$  to  $+160 \pm 2^{\circ}\text{F}$ . Internal dimensions of the chamber are 7' 6" wide by 15' 2" long by 8' high. This chamber was used for conditioning the container at  $-65^{\circ}\text{F}$  and  $+140^{\circ}\text{F}$  for the Low and High Temperature Drop Tests.

DROP TEST: The drop tests were performed in a drop test area which consists of a one-half inch thick steel plate 10 ft by 10 ft imbedded in the top surface of a 12-inch slab of concrete.

QUICK RELEASE: A manually operated quick release mechanism was used for drop testing.

#### PENDULUM IMPACT TESTER

TIRE DROP TEST MACHINE: Due to the size of the container the superimposed load test had to be performed at the Air Force Flight Dynamics Laboratory (AFFDL) Landing Gear Test Facility. The 10,300 lbs capacity drop test machine was used to apply the superimposed load.

VIBRATION TABLES: The vibration table used for the repetitive shock test was manufactured by L.A.B. Corp.; it operates between 0 - 40 cps and has a 5000-lb capacity at 3g maximum with a double amplitude capability up to 1.0 inch.

A second vibration table was used for the sinusoidal motion test; it was manufactured by MTS Corp. This vibration table is located at the AFFDL Landing Gear Test Facility. The vibrating mode is limited by the following (with a 35,000-lb dead weight test article): 25-inch double amplitude from 0 to 0.4 Hz, 30-in/sec velocity from 0.4 Hz to 3 Hz, 2g acceleration from 3 Hz to 50 Hz.

TEST PROCEDURES: All tests, except **Test Nos. 1 & 10**, were conducted in accordance with a referenced method of FED-STD-101B. **Test Nos. 1 and 10** were conducted in accordance with Exhibit AFALD/P TPP 79-1, dated 14 March 1979.

TEST NO. 1: The examination of product was conducted by AFALD/P TPP in accordance with paragraph 4.5 of Exhibit AFALD/P TPP 79-1.

TEST NO. 2: Pneumatic Pressure Test was conducted in accordance with Method 5009 Pneumatic Pressure Technique, except that the inflation pressure was 1.5 PSID.

TEST NO. 3: Superimposed - load test was conducted in accordance with Method 5016 except that the applied load was equivalent to the weight of two like containers with contents.

TEST NO. 4: Vibration (Sinusoidal Motion) test was to be conducted in accordance with Method 5020.

TEST NO. 5: High Temperature Drop Tests, Edgewise Drops in accordance with Method 5008 and Cornerwise Drops in accordance with Method 5005, were conducted. Prior to drop tests the container was conditioned at 140°F for a minimum of 24 hours. The specimen was then removed from the chamber and dropped twice, placed back in the chamber for twice the duration of time it was removed. After this additional conditioning, the specimen was removed and the remaining two drops conducted.

TEST NO. 6: Low Temperature Drop Tests, Edgewise Drops in accordance with Method 5008 and Cornerwise Drops in accordance with Method 5005, were conducted with the specimen conditioned for a minimum of 24 hours prior to drop testing at -65°F. The specimen was then removed from the chamber and dropped twice, placed back in the chamber for twice the duration of time it was removed. After this additional conditioning, the specimen was removed and the remaining two drops conducted.

TEST NO. 7: Vibration (Repetitive Shock) Test was conducted in accordance with Method 5019.

TEST NO. 8: Pendulum Impact Test was to be conducted in accordance with Method 5012.

TEST NO. 9: Mechanical Handling Test was to be conducted in accordance with Method 5011.

Forklift Handling	Paragraph 6.2
Pushing	Paragraph 6.5
Towing	Paragraph 6.6
Sling Handling	Paragraph 6.3.2

except that the sling formed an angle of 45° with the horizontal instead of 20 to 25° as specified.

TEST NO. 10: Drainage Test was conducted in accordance with Paragraph 4.6.9 of Exhibit AFALD/PTPP 79-1.

TEST NO. 11: Pneumatic Pressure Test was a repeat of Test No. 2.

#### TEST RESULTS

TEST NO. 2 PNEUMATIC PRESSURE TEST: The container relief valve was removed, the container was sealed and the tee-bolts were torqued to 50 in-lbs. The container was pressurized to 1.46 PSID. After 30 minutes the pressure dropped to 1.30 PSID. Air was escaping from around the heads of the tee-bolts.

TEST NO. 3 SUPERIMPOSED-LOAD TEST: The gross weight of the container, suspension system and simulated core was 2297 lbs; therefore, the superimposed load was to be 4594 lbs. The actual applied load was 4615 lbs (see Figure 6). The container had no cracks buckling or failure of members during the test. There was only slight (insignificant) vertical deflections or bulging of the sides/ends.

TEST NO. 4 VIBRATION (SINUSOIDAL MOTION) TEST: The container was strapped to the table with 12 steel straps each 1-1/4 inch wide and 3 chains with turnbuckles (see Figure 7). The container was vibrated per the following chart:

Frequency (cps)	Double Amplitude (inches)	Duration
2.0	1.0	5 min
3.0	1.0	5 min
5.0	1.0	5 min
6.2	1.35	35 sec
6.2	0.67	70 sec

The vibration table operator misunderstood the test procedure and doubled the 6.2 cps double amplitude of 0.67 inch to 1.35 inch. The test was stopped and the amplitude reduced to its correct value and the test was continued. Following the 6.2 cps at 0.67 inch double amplitude the amplitude was being reduced prior to increasing the frequency for the next test point when two of the elastomeric shock mounts failed. Figure 8 shows which shear mounts failed.

TEST NO. 5 HIGH TEMP DROP TESTS (+140°F): There was no damage to the container and the accelerations recorded are as follows:

Accelerometer Location	Accelerations (G)				
	1	2	3	4	5
	Lateral-CG	Longitudinal	CG Vertical	Forward Vertical	Rear Vertical
Drop					
#1 Front Edge	0.2	2.4	9.3	15.6	7.7
#2 Left Front Corner	0.3	4.9	9.4	13.3	5.5
#3 Rear Edge	2.8	2.6	9.9	5.1	14.1
#4 Right Rear Corner	1.9	1.7	8.0	2.7	11.7

TEST NO. 6 LOW TEMP DROP TEST (-65°F): There was no damage to the container other than a few small chips in the Gel Coat. Recorded accelerations are as follows:

Accelerometer Location	Accelerations (G)				
	1	2	3	4	5
	Lateral-CG	Longitudinal	CG Vertical	Forward Vertical	Rear Vertical
Drop					
#1 Rear Edge	0.6	5.0	19.5	3.7	17.6
#2 Rear Left Corner	3.2	3.4	16.8	4.9	14.2
#3 Front Edge	1.8	3.0	26.3	21.3	7.6
#4 Front Right Corner	2.4	3.3	17.5	15.9	6.5

TEST NO. 6A ROOM TEMP DROP TESTS: The only damage to the container was that one shear pin/location pin in the end of the container was sheared off and the remaining shear pins were bent. Recorded accelerations are as follows:

Accelerometer Location	Accelerations (G)				
	1	2	3	4	5
	Lateral-CG	CG Longitudinal	CG Vertical	Forward Vertical	Rear Vertical
Drop					
#1 Front Edge	2.6	1.5	14.3	16.6	7.5
#2 Left Front Corner	2.7	2.2	10.5	14.4	7.3
#3 Rear Edge	0	1.2	11.6	4.1	13.9
#4 Right Rear Corner	1.0	0.7	7.1	3.7	13.7

TEST NO. 7 VIBRATION (REPETITIVE SHOCK) TEST: The frequency was 4 cps and a 1/16-inch "feeler" gage was slid under the container. There were no cracks or failures in the container. Recorded accelerations are as follows:

Accelerometer Location	Accelerations (G)				
	1	2	3	4	5
	Lateral-CG	CG Longitudinal	CG Vertical	Forward Vertical	Rear Vertical
Drop					
Average Acceleration	1.7	1.1	3.5	3.7	3.4

**TEST NO. 8 PENDULUM IMPACT TEST:** The front of the container was not impacted due to the Drain Plug protruding from the container wall. It was felt that if the front side of the container was impacted, the drain plug would have been pushed through the wall of the container. After testing three sides there was no apparent damage to the container. Recorded accelerations are as follows:

Accelerometer Location	Accelerations (G)				
	1	2	3	4	5
	Lateral-CG	CG Longitudinal	CG Vertical	Forward Vertical	Rear Vertical
Drop					
Right Side	6.9	1.1	0	0.3	0.4
Rear Side	0	7.1	1.4	4.4	2.3
Left Side	7.7	0	2.0	1.8	1.9

**TEST NO. 9 MECHANICAL HANDLING TEST:**

Forklift Handling - The forks were 73 inches long and during this test the mast was tilted all the way back. The container was very stable while lifting container from this side. The container rocked slightly when lifting container from the end.

Pushing - The mast was tilted slightly back. Some fiberglass was left on the cement surface. An excessive amount of fiberglass was not abraded from the bottom of the container.

Towing - As in the pushing test some fiberglass was left on the concrete surface but it was not excessive.

Sling Handling - With the container suspended from two diagonally opposite attachment points, the container was very stable. There was a slight bulging of the container walls at the lift rings.

The container was lifted clear of the ground by one tiedown ring for two minutes, and then repeated with each of the other tiedown rings. Cracking in the Gel Coat was found around all the attachment points. The attachment rings were 2 inches by 3-1/8 inches before the test and approximately 1-3/4 inches by 3-1/2 inches after the test. While testing one tiedown ring, severe cracking and popping sounds were heard, therefore, the container was set down after being suspended for 30 seconds.

**TEST NO. 10 DRAINAGE TEST:** Water collected in the tee-bolt receptacles. The water drained very slowly from the receptacles; after 5 minutes the water was still standing in the tee-bolt receptacles.

**TEST NO. 11 PNEUMATIC PRESSURE TEST:** The container was sealed and the tee-bolts were torqued to 55 in-lbs. The container was pressurized to 1.51 PSID, after 30 minutes the pressure dropped to 1.36 PSID.

## CONCLUSION

1. The pressure relief valve for this container is specified to have a cracking pressure between .25 and .75 psi. Therefore, the leakage noted during the pneumatic pressure test above .75 psi is not considered to be significant in regard to the amount of desiccant needed to maintain an acceptably dry environment within the container. However, further testing revealed leakage below .75 psi and through analysis it was found that the closure flange was not formed properly and should be corrected during fabrication of production containers. In addition, all production containers should be pressure tested as a quality control measure.
2. Container performance during the vibration portion of the test program was considered acceptable. The isolation system tested was the one presently used in metal containers which have been in service for several years with no report of damage. During Test No. 7, vibration (repetitive shock) the isolation system afforded adequate protection with no apparent damage to the container or excessive accelerations recorded on the test item. During Test No. 4, vibration (sinusoidal motion) the shear mounts failed. After further testing and analysis it was determined during this test that overheating and subsequent failure would occur. Consequently, further testing was discontinued. In view of acceptable performance of this system in the past along with the common practice to ship the engine in air-ride vans, the failure during this phase of vibration test was not considered significant enough to warrant redesign of the container.
3. The drain plug should be placed in a recessed area to eliminate possible damage to the container. Because of these relatively low accelerations recorded on the other 3 container sides further pendulum testing will not be required after the design change is accomplished.
4. The hoisting and tie down provisions need to be reinforced along with the cover lift rings. Testing should be conducted after this design change to verify performance.
5. Although the shear/location pins in the closure flange did show damage, after the third set of drop tests, it was determined that a design change and further tests would not be justified.
6. The tee-bolt receptacles were not designed to afford drainage of water as specified in the statement of work. A simple design change can correct this deficiency.

**AIR FORCE PACKAGING EVALUATION AGENCY**  
(Container Test Plan)

APPEA PROJECT NUMBER  
79-p7-73

CONTAINER SIZE	(GROSS) WT	(ITEM)	CUBE	QUANTITY	DATE
99.25x61.7x62.9	2500	1080	227.91 ft <sup>3</sup>	1	12 Dec 79
ITEM NAME			MANUFACTURER		
F100 Core Engine Module			Plastics Research Corporation		
CONTAINER NAME			CONTAINER COST		
F100 Core Engine Module Container			NA		
PACK DESCRIPTION					
Fiberglass Reinforced Plastic with Elastomeric Shock Isolation System					
CONDITIONING					

TEST NO.	IAW	PARAMETERS	Schedule	INSTRUMENTED
1	SOW	Examination product (To be conducted by PTPP)		
2	Method 5009 FED-STD-101B	Pneumatic Pressure Test Pneumatic Pressure Technique (1.5 PSIG)	18 Dec	Pressure Transducer
3	Method 5016 FED-STD-101B	Superimposed-load Test Except that the load applied shall be equivalent to the weight of two like containers.	20 Dec	
4	Method 5020 FED-STD-101B	Vibration (Sinusoidal Motion) Test	21 Dec	Accelerometers
5	FED-STD-101B Method 5008 Method 5005	High Temp Drop Test (+140°F) Edgewise Drops Cornerwise Drops	2 Jan	Accelerometers
6	FED-STD-101B Method 5008 Method 5005	Low Temp Drop Test (-65°F) Edgewise Drops Cornerwise Drops	4 Jan	Accelerometers
7	Method 5019 FED-STD-101B	Vibration (Repetitive Shock) Test	7 Jan	Accelerometers

**COMMENTS** For test 5 and 6 conditioning of the specimen for 24 hours prior to drops will be required. The specimen will then be removed from the chamber and dropped twice, then placed back in the chamber for twice the time it was removed. After this time the specimen will be removed and the remaining two drops conducted.

Note: This is a revision of the 31 Oct 79 Test Plan.

PREPARED BY <i>James T. Steiger</i> JAMES T. STEIGER	APPROVED BY <i>Ralph Zynda</i> RALPH ZYNDA
--	--

FIGURE 1. CONTAINER TEST PLAN

AIR FORCE PACKAGING EVALUATION AGENCY (Container Test Plan)					AFPEA PROJECT NUMBER	
CONTAINER SIZE	(GROSS)	WT	(ITEM)	CUBE	QUANTITY	DATE
ITEM NAME				MANUFACTURER		
CONTAINER NAME				CONTAINER COST		
PACK DESCRIPTION						
CONDITIONING						
TEST NO.	IAW	PARAMETERS		Schedule	INSTRUMENTED	
8	Method 5012 FED-STD-101B	Pendulum Impact Test		8 Jan	Accelerometers	
9	Method 5011 FED-STD-101B	Mechanical Handling Test		8 Jan		
		a. Forklift Handling Para 6.2		8 Jan		
		b. Pushing Para 6.5		8 Jan		
		c. Towing Para 6.5		8 Jan		
		d. Sling Handling Para 6.3.2		9 Jan		
10	Para 4.6.9 Exhibit AFALD/PTPP 79-1 (14 Mar 79)	Drainage		9 Jan		
11	Method 5009 FED-STD-101B	Pneumatic Pressure Test (Repeat Test No. 2)		10 Jan	Pressure Transducer	
<b>COMMENTS</b> Test sequence may be altered upon availability of test equipment.						
<b>PREPARED BY</b> JAMES T. STEIGER				<b>APPROVED BY</b> RALPH ZYNDA		

AFALD FORM FEB 77 4

FIGURE 1. CONTAINER TEST PLAN (CONT'D)

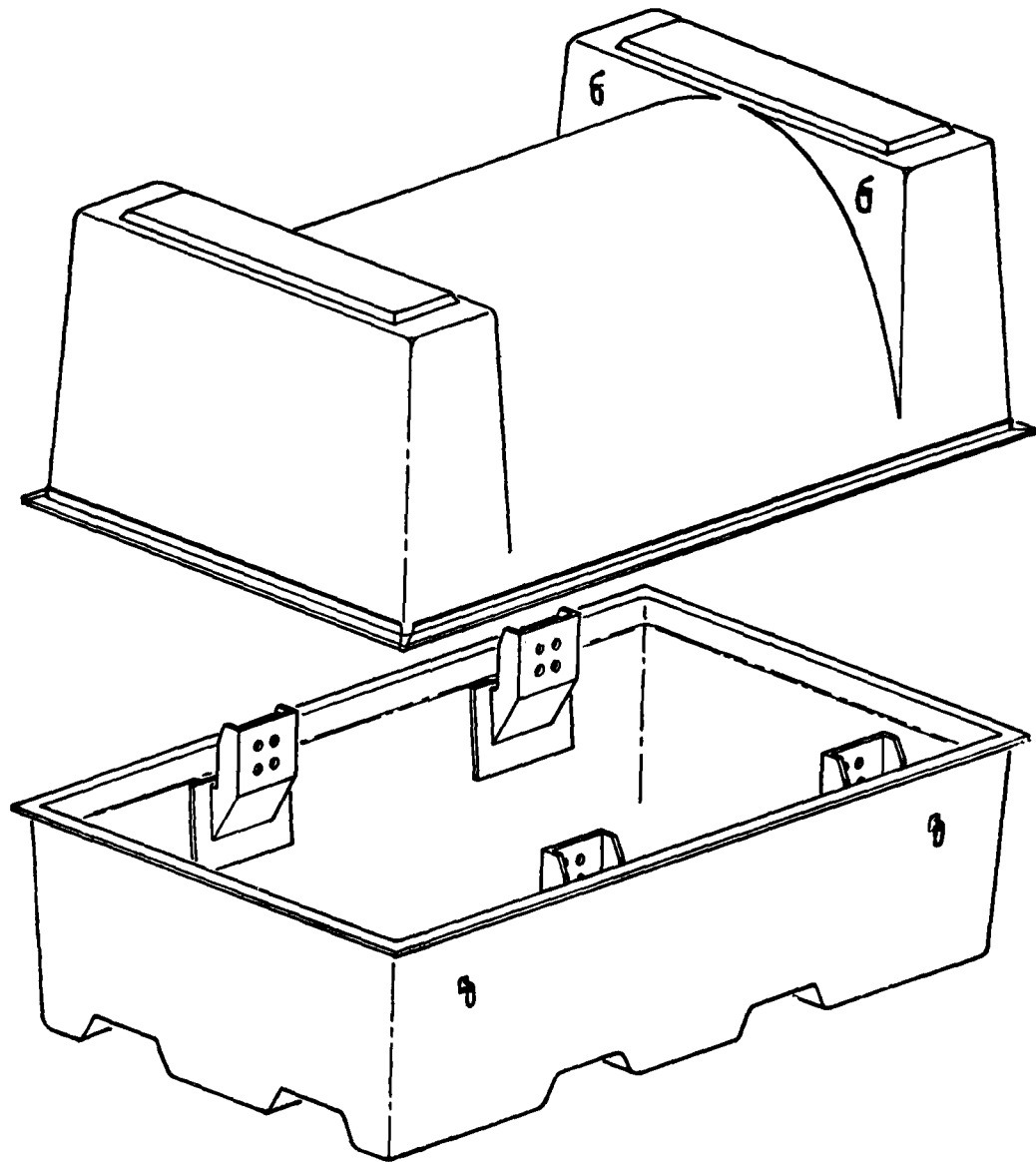

FIGURE 2. FRP CONTAINER

FIGURE 3. SUSPENSION SYSTEM

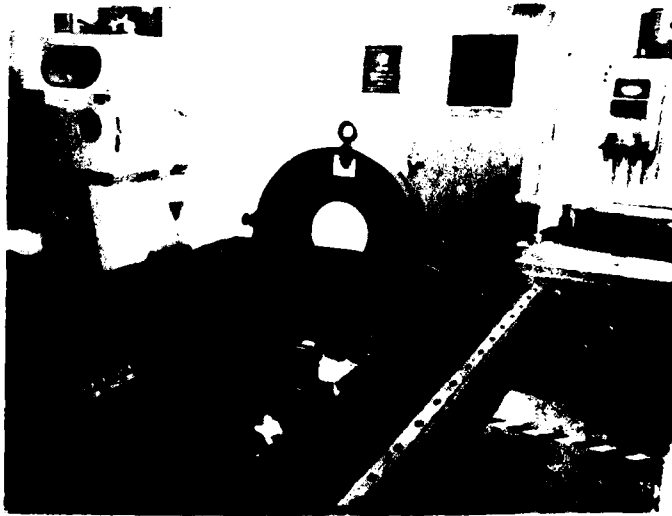

FIGURE 4. SIMULATED CORE MODULE  
MOUNTED IN FRP CONTAINER



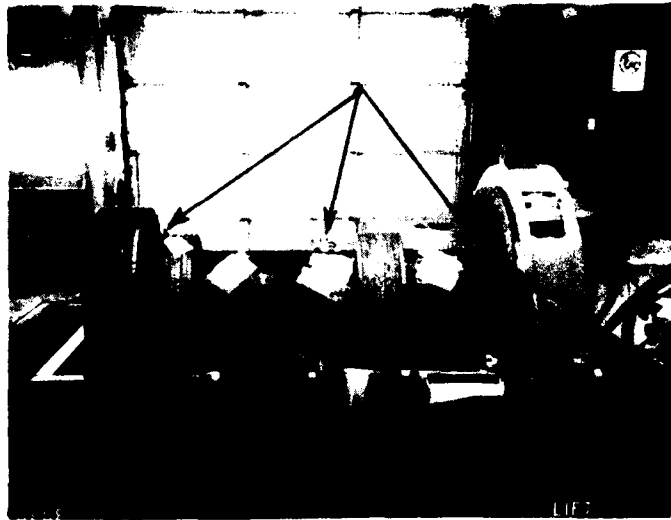

FIGURE 5. DIAGRAM OF ACCELEROMETER LOCATIONS  
ON CORE ENGINE MODULE



FIGURE 6. SUPERIMPOSED LOAD

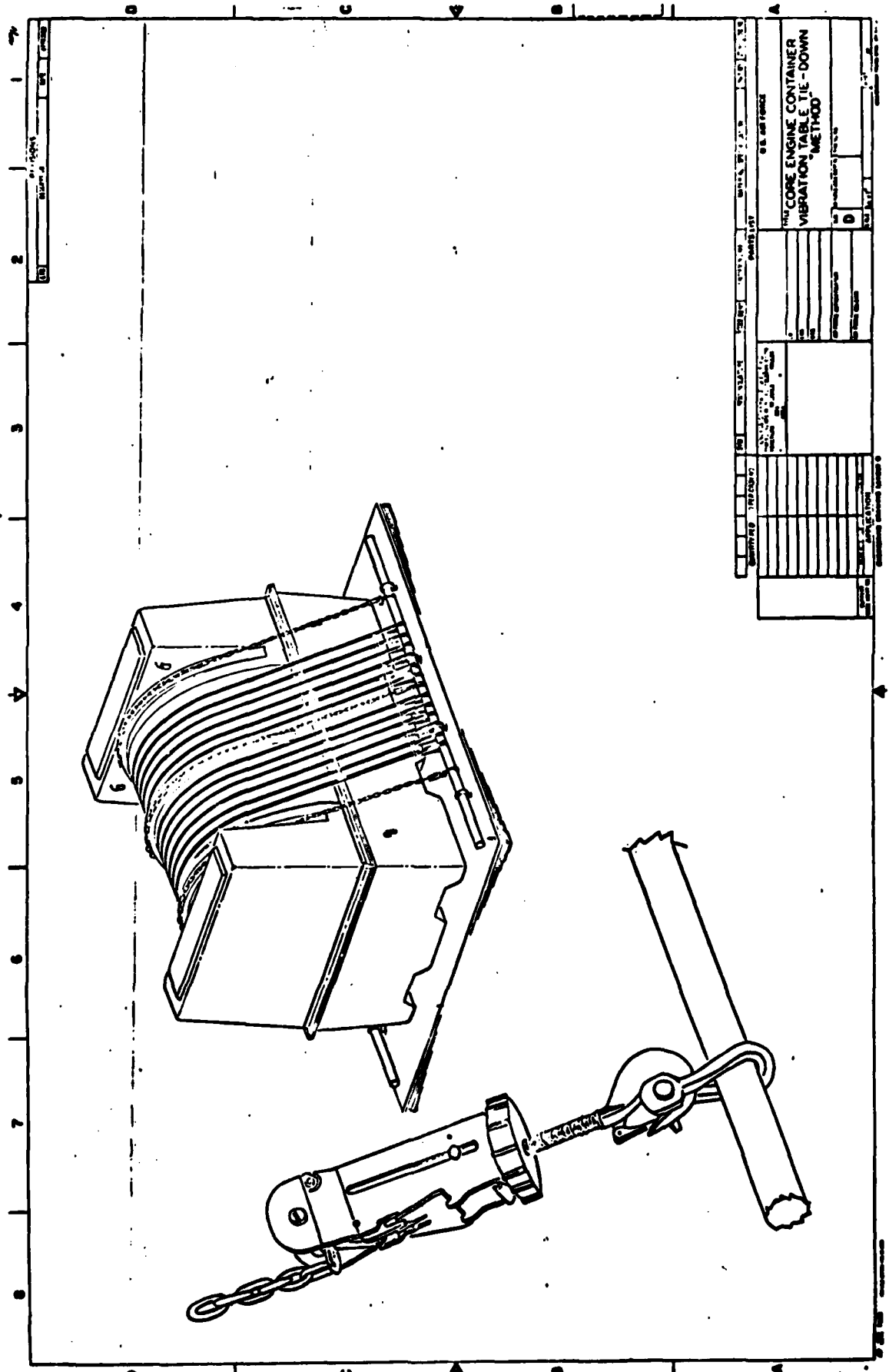

FIGURE 7. VIBRATION TABLE WITH CONTAINER FASTENED DOWN

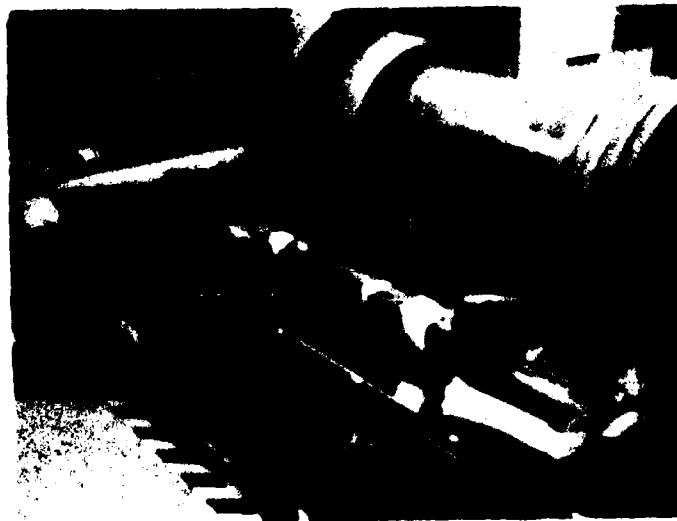
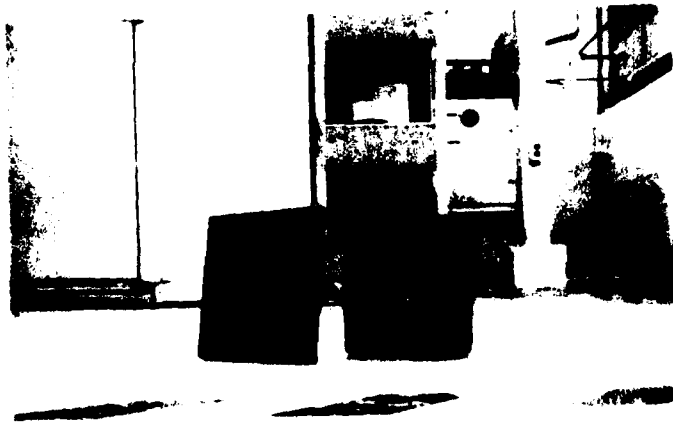

FIGURE 8. BROKEN SHEAR MOUNT