

TR 79125

UNLIMITED

TR 79125

18 DRIC

19 BR 72505



2 LEVEL II

ROYAL AIRCRAFT ESTABLISHMENT

1

9 * 14 RAE-TR-

Technical Report 79125

12 239

11 September 1979

6 THEORETICAL DETERMINATION OF SUBSONIC OSCILLATORY AIRFORCE COEFFICIENTS FOR FIN-TAILPLANE CONFIGURATIONS.

by

10 D.E. Davies

DTIC ELECTE JUN 12 1980 S D

B

*

Procurement Executive, Ministry of Defence Farnborough, Hants

ADA 085863

DDC FILE COPY

80 6 6 025

310450

Handwritten signature or initials

UDC 629.13.012.69 : 629.13.012.674 : 533.6.013.42 :
533.6.048.1 : 533.6.011.32/.34

ROYAL AIRCRAFT ESTABLISHMENT

Technical Report 79125

Received for printing 26 September 1979

THEORETICAL DETERMINATION OF SUBSONIC OSCILLATORY AIRFORCE COEFFICIENTS
FOR FIN-TAILPLANE CONFIGURATIONS

by

D. E. Davies

SUMMARY

The fin-tailplane configuration consists of two flat half-tailplanes and a flat fin joined together so as to be symmetric about the plane of the fin. The half-tailplanes may be set at a non-zero dihedral angle to each other. The chords of all the surfaces at their junction are of the same length and are coincident. The fin-tailplane configuration is assumed to be isolated and to be oscillating harmonically about its mean position in a subsonic flow whose main stream is parallel to the junction chord. The oscillatory motion is taken to be antisymmetric about the plane of the fin. Linearised equations of potential flow are assumed to be valid so that the normal velocities on the fin and tailplane surfaces may be related to the loadings on these surfaces by means of linear integral equations. These integral equations are solved numerically for the loadings for oscillation at general frequency in any antisymmetric modes, and the generalised airforce coefficients are then obtained. Approximations to the loadings are taken as linear combinations of basis functions. The condition satisfied by the loadings at the junction of the fin and half-tailplanes is imposed on the approximations and the variational principle of Flax is applied to get the coefficients in the said linear combinations. The method is more elaborate than that of a previous theory of the author. The procedure has been programmed in ICL 1900 FORTRAN. Results obtained using the program on a number of examples are given.

Departmental Reference: Structures BF/B/0794

Copyright

©

Controller HMSO London

1979

LIST OF CONTENTS

| | <u>Page</u> |
|---|-------------|
| 1 INTRODUCTION | 3 |
| 2 THEORETICAL CONSIDERATIONS | 6 |
| 2.1 Preliminary formulae | 6 |
| 2.2 Approximate solution of the integral equations | 13 |
| 2.3 Evaluation of the loading on the surfaces S_1 and S_2 | 39 |
| 3 NUMERICAL INTEGRATION | 44 |
| 3.1 Evaluation of $\psi_{i,j;r,s}^{(1,1)}$ | 44 |
| 3.2 Evaluation of $\psi_{i,j;r,s}^{(2,2)}$ | 55 |
| 3.3 Evaluation of $\psi_{i,j;r,s}^{(1,2)}$ | 59 |
| 3.4 Evaluation of $\psi_{i,j;r,s}^{(2,1)}$ and $\psi_{i,j;r,s}^{(2,3)}$ | 63 |
| 4 EXAMPLES | 70 |
| 4.1 Rectangular half-tailplanes of aspect ratio 1 and rectangular fin of aspect ratio 1. Zero dihedral angle α | 70 |
| 4.2 Rectangular half-tailplanes of aspect ratio $\frac{1}{2}$ and rectangular fin of aspect ratio 1. Zero dihedral angle α | 72 |
| 4.3 Swept-back half-tailplanes and swept-back fin. Zero dihedral angle α | 73 |
| 4.4 The Stark fin-tailplane configuration | 74 |
| 4.5 Swept-back half-tailplanes and swept-back fin. General dihedral angle α | 76 |
| 4.6 Second case of swept-back half-tailplanes and swept-back fin. General dihedral angle α | 79 |
| 5 CONCLUSIONS | 81 |
| Appendix A Numerical integration formulae | 83 |
| Appendix B Numerical evaluation at $\eta_0 = \chi_q^{(m_1', \bar{m}_1)}$ of $I_r^{(n)*} \left(\bar{\xi}_p^{(n_1')}, \chi_q^{(m_1', \bar{m}_1)}, \eta_0; \nu, M \right)$ and its first two derivatives with respect to η_0 | 93 |
| Appendix C Numerical evaluation of certain integrals appearing in Appendix B | 129 |
| Appendix D Expression of $I(\theta)$ in terms of Chebyshev polynomials | 151 |
| Appendix E Analytical evaluation of spanwise integrals | 170 |
| Appendix F Numerical evaluation of $y^4 F(x, y; \nu, M)$ | 172 |

LIST OF CONTENTS (concluded)

| | <u>Page</u> |
|---------------------------|-------------------|
| Tables 1 to 14 | 181 |
| List of symbols | 220 |
| References | 229 |
| Illustrations | Figures 1-6 |
| Report documentation page | inside back cover |

S DTIC
 ELECTE **D**
 JUN 12 1980
B

| | | |
|---------------------------------|---------------|-------------------------------------|
| ACCESSION for | | |
| NTIS | White Section | <input checked="" type="checkbox"/> |
| DDC | Buff Section | <input type="checkbox"/> |
| UNANNOUNCED | | <input type="checkbox"/> |
| JUSTIFICATION _____ | | |
| BY _____ | | |
| DISTRIBUTION/AVAILABILITY CODES | | |
| Dist. | AVAIL. and/or | SPECIAL |
| A | | |

79125

1 INTRODUCTION

The theory to be described is a development of the author's previous theory¹ for the calculation of subsonic oscillatory airforce coefficients for fin-tailplane configurations oscillating antisymmetrically about the plane of the fin in a harmonic motion. A pair of linearised integral equations connects the loading distributions on the fin and a half-tailplane with the normal air velocities on these surfaces. The loading distributions on the fin and half-tailplane are approximated by linear combinations of given continuous basis functions that have the proper edge behaviour, so that the theory is of the lifting-surface type. The loading distributions satisfy a condition at the junction of the fin and half-tailplanes. Previously¹ this junction condition was ignored, but found to be satisfied approximately by the solution obtained. Here we impose the junction condition on the approximate loading distributions, and this has the repercussion that the former method of simple collocation at sets of points on the fin and a half-tailplane is not easily applied to determine the coefficients in the above linear combinations. However, an application of Flax's variational principle^{2,3} yields a set of equations for determining the said coefficients. Normal air velocities at specific points on the fin and half-tailplane may still be used in this application. Having determined the coefficients, we then obtain the generalised airforce coefficients for the fin-tailplane in a straightforward manner.

The opportunity has been taken, in refining the theory, to incorporate the possibility of the dihedral angle between the two half-tailplanes being non-zero, but the angles of incidence of all surfaces to the main-stream flow remain zero as before¹. Furthermore, the chords of the fin and the half-tailplanes at their junction are again of equal length and coincident.

In the past 15 years or so, several authors have developed theories for calculating subsonic oscillatory airforce coefficients for fin-tailplane configurations. Immediately prior to the author's previous theory¹, Stark published a theory⁴ which was based on integral equations involving the integrated acceleration potential. The author's previous theory was subsequently applied to the example taken by Stark, and results in good agreement with those of Stark were obtained. This same example was used, for comparison, by several authors afterwards and is here used again with the present theory.

Zwaan⁵ used the same kind of lifting-surface theory as the author's¹ although there are differences of detail. There followed a number of such lifting-surface theories, eg Böhm and Schmid⁶ and Isogai⁷. Only Stark⁴ adopted

a procedure equivalent to imposing the junction condition on the loading. Isogai introduced a non-zero angle of incidence for the tailplane surfaces but this was only for rigid body oscillations and for incompressible flow.

In a later theory Stark⁸ solved the integral equations connecting the doublet strengths on the fin and half-tailplane surfaces and on the wakes emanating from the trailing edges of these surfaces. From the doublet strengths, the loadings and subsequently the airforce coefficients are easily calculated. Stark carries out numerical integration of his surface integrals in terms of polar coordinates as integration variables and gets a more rapid evaluation, for a given accuracy, than he would obtain using the conventional cartesian coordinates as integration variables. The method is, however, of the lifting-surface type.

The doublet-lattice type of method is different in that the loading distributions on the fin and half-tailplane are approximated by discrete concentrated loadings on certain lines on these surfaces. The same pair of linearised integral equations connecting the loading distributions on the fin and the half-tailplane remain to be solved. This type of method was used by Rodden, Giesing and Kálmán⁹ and has been used more recently by Nayler and Doe¹⁰. Results obtained by Nayler and Doe are compared with results obtained by the present method for a fin-tailplane configuration which is a slight modification of the standard AGARD configuration taken in Ref 6.

The method presented here is again of the lifting-surface type but it is different from the earlier versions described above in that the coefficients in the expressions for the approximate loadings are determined by applying Flax's variational principle^{2,3}. The condition on the loading at the fin-tailplane junction is satisfied. The method is more powerful than the author's former method¹ and should give better approximations to the generalised airforce coefficients with a comparable amount of numerical calculation.

2 THEORETICAL CONSIDERATIONS

2.1 Preliminary formulae

The fin-tailplane configuration consists of two half-tailplanes and a fin joined together. The half-tailplanes and the fin are very thin and nearly plane. The whole fin-tailplane configuration is immersed in a subsonic airstream with the inclinations of its surfaces to the main airstream direction being very small. The fin-tailplane is oscillating in a prescribed manner with small excursion about a mean position. Accordingly linearised aerodynamic theory is

applicable and the fin-tailplane may, for the purpose of finding the aerodynamic forces acting on it, be replaced by intersecting plane surfaces of infinitesimal thickness, all parallel to the main airstream direction, with the normal component of the air velocity across these surfaces known. A diagram of these intersecting plane surfaces is given in Fig 1. The fin ABCD is joined to the half-tailplanes CDEF and CDHG along the chord line of junction CD. The half-tailplanes are images of each other in the plane of the fin ABCD.

A section through the fin-tailplane by a plane normal to the main airstream is shown in Fig 2, the direction of the airstream being normal into the paper. It illustrates the disposition to each other of the fin and the two half-tailplanes. The fin planform ABCD and half-tailplane planforms CDEF and CDHG will be called the surfaces S_1 , S_2 and S_3 respectively. The normal to the fin is at an angle α to the surfaces of both the half-tailplanes, and this angle α is taken to be the measure of the dihedral of the two half-tailplanes. This dihedral angle α is reckoned positive when the angle between the fin surface and a tailplane surface exceeds a right angle. With this reckoning, a tailplane situated at the bottom of a fin would have conventional anhedral when α is positive. Positive normal directions to the three surfaces S_1 , S_2 and S_3 are chosen in the sense shown in Fig 2.

A system of right-handed cartesian coordinates (x,y,z) is introduced, relative to which the mean positions of the oscillating surfaces are fixed. The origin 0 of coordinates is taken to be a point on the line of junction CD. The positive direction of x is that of the main airstream and is therefore in the direction DC. The axis of z is in the plane of the fin S_1 , positive towards the end AB of the fin. The axis of y is mutually perpendicular to the axes of x and z with positive sense to complete a right-handed cartesian coordinate system.

Further, a local coordinate axis u passing through 0 is introduced as a surface axis for each of the half-tailplane surfaces S_2 and S_3 so that surface coordinates may be introduced. For each of the half-tailplanes the positive direction of the axis is towards the tip. The position of a point on a specified half-tailplane is known when its surface coordinates (x,u) are known. On the half-tailplane S_2 (Fig 2) the point with surface coordinates (x,u) has space coordinates $(x, u \cos \alpha, -u \sin \alpha)$ whereas on the half-tailplane S_3 it has space coordinates $(x, -u \cos \alpha, -u \sin \alpha)$. Equally the position of a point on the fin S_1 is known when its surface coordinates (x,z) are known. On the fin the point with surface coordinates (x,z) has space coordinates $(x,0,z)$.

When the fin-tailplane configuration is vibrating the displacements normal to the surfaces are defined as positive in the directions indicated in Fig 2. For the surfaces S_1 , S_2 and S_3 the normal displacements at time t are taken to be $N^{(1)}(x,z,t)$, $N^{(2)}(x,u,t)$ and $N^{(3)}(x,u,t)$ respectively at the point with surface coordinates (x,z) on S_1 and the points with surface coordinates (x,u) on S_2 and S_3 .

We assume that the fin-tailplane is capable of oscillation in modes that can be numbered 1, 2, 3, ..., etc. For oscillation in mode number q we may write

$$N^{(1)}(x,z,t) = \ell f_q^{(1)}(x,z) b_q(t) \quad (2-1)$$

$$N^{(2)}(x,u,t) = \ell f_q^{(2)}(x,u) b_q(t) \quad (2-2)$$

$$N^{(3)}(x,u,t) = \ell f_q^{(3)}(x,u) b_q(t) \quad (2-3)$$

where ℓ is a typical linear dimension of the fin-tailplane, $f_q^{(1)}(x,z)$, $f_q^{(2)}(x,u)$, $f_q^{(3)}(x,u)$ are the q th modal functions, and $b_q(t)$ is the q th generalised coordinate which determines the extent of the displacements of the fin-tailplane in the mode number q at time t .

It is sufficient, in linearised theory, to consider harmonic oscillations only, because the principle of superposition holds, and can be used to build any general oscillation from simple harmonic oscillations. Accordingly we may take for the function $b_q(t)$ the expression

$$b_q(t) = \bar{b}_q e^{i\omega t} \quad (2-4)$$

where ω is the circular frequency of the harmonic oscillation and \bar{b}_q is a complex number. The function $b_q(t)$ given by formula (2-4) is a complex function of time t but we can use it and its complex conjugate to form a real function

$$\frac{1}{2} \left(\bar{b}_q e^{i\omega t} + \bar{b}_q^* e^{-i\omega t} \right) \quad (2-5)$$

where \bar{b}_q^* is the complex conjugate of \bar{b}_q . Then by using the principle of superposition, any results for the real harmonic function (2-5) can be obtained from the corresponding results for the complex harmonic function $b_q(t)$ given by (2-4). The quantity \bar{b}_q may, in particular, be a real number but the functions $f_q^{(1)}(x,z)$, $f_q^{(2)}(x,u)$, $f_q^{(3)}(x,u)$ must all be real.

From the boundary condition that the airflow be tangential to the fin and tailplane surfaces we get linearised expressions for the normal velocity components $W^{(1)}(x,z,t)$, $W^{(2)}(x,u,t)$ and $W^{(3)}(x,u,t)$ at the mean positions of the surfaces S_1 , S_2 and S_3 in terms of the normal displacements $N^{(1)}(x,z,t)$, $N^{(2)}(x,u,t)$, $N^{(3)}(x,u,t)$. These linearised expressions, for harmonic oscillation at circular frequency ω in the q th mode, are

$$W^{(1)}(x,z,t) = V\bar{b}_q w_q^{(1)}(x,z;\nu)e^{i\omega t} \quad (2-6)$$

$$W^{(2)}(x,u,t) = V\bar{b}_q w_q^{(2)}(x,u;\nu)e^{i\omega t} \quad (2-7)$$

$$W^{(3)}(x,u,t) = V\bar{b}_q w_q^{(3)}(x,u;\nu)e^{i\omega t} \quad (2-8)$$

where $w_q^{(1)}(x,z;\nu) = \ell \frac{\partial}{\partial x} f_q^{(1)}(x,z) + i\nu f_q^{(1)}(x,z) \quad (2-9)$

$$w_q^{(2)}(x,u;\nu) = \ell \frac{\partial}{\partial x} f_q^{(2)}(x,u) + i\nu f_q^{(2)}(x,u) \quad (2-10)$$

$$w_q^{(3)}(x,u;\nu) = \ell \frac{\partial}{\partial x} f_q^{(3)}(x,u) + i\nu f_q^{(3)}(x,u) \quad (2-11)$$

are scaled normal velocities,

$$\nu = \frac{\omega \ell}{V} \quad (2-12)$$

is the frequency parameter and V is the speed of the main stream.

Corresponding to the normal velocity components $W^{(1)}(x,z,t)$, $W^{(2)}(x,u,t)$ and $W^{(3)}(x,u,t)$, there are normal pressure forces per unit area $L^{(1)}(x,z,t)$, $L^{(2)}(x,u,t)$ and $L^{(3)}(x,u,t)$ across the surfaces S_1 , S_2 and S_3 respectively. These pressure forces per unit area are called the aerodynamic loadings on the surfaces and are reckoned positive when the forces act in the positive normal directions to the surfaces. For harmonic oscillation in the q th mode, where the normal components $W^{(1)}(x,z,t)$, $W^{(2)}(x,u,t)$ and $W^{(3)}(x,u,t)$ of the air velocities are given by the formulae (2-6) to (2-8), we may write

$$L^{(1)}(x,z,t) = \rho V^2 \bar{b}_q \ell_q^{(1)}(x,z;\nu,M)e^{i\omega t} \quad (2-13)$$

$$L^{(2)}(x,u,t) = \rho V^2 \bar{b}_q \ell_q^{(2)}(x,u;\nu,M)e^{i\omega t} \quad (2-14)$$

$$L^{(3)}(x,u,t) = \rho V^2 \bar{b}_q \ell_q^{(3)}(x,u;\nu,M) e^{i\omega t} \quad (2-15)$$

where $M = \frac{V}{a}$ (2-16)

is the Mach number and ρ and a are the air density and speed of sound in the main stream.

On using the governing partial differential equation for the perturbation velocity potential, the boundary conditions of prescribed normal components of the air velocities on the surfaces S_1 , S_2 and S_3 , and the condition of no loading across the wakes shed from the trailing edges of these surfaces, we can set up, as in Ref 1, three integral equations relating the normal components of the air velocities on the surfaces S_1 , S_2 and S_3 with the aerodynamic loading on them. These integral equations may be written in the form

$$\begin{aligned} w_q^{(1)}(x,z;\nu) &= \frac{1}{4\pi\ell^2} \iint_{S_1} \ell_q^{(1)}(x_0,z_0;\nu,M) K_1\left(\frac{x-x_0}{\ell}, \frac{z-z_0}{\ell}; \nu,M\right) \\ &\quad \times \exp\left\{-i\nu \frac{(x-x_0)}{\ell}\right\} dx_0 dz_0 \\ &+ \frac{1}{4\pi\ell^2} \iint_{S_2} \ell_q^{(2)}(x_0,u_0;\nu,M) K_2\left(\frac{x-x_0}{\ell}, \frac{u_0}{\ell}, \frac{z}{\ell}, \frac{1}{2}\pi + \alpha; \nu,M\right) \\ &\quad \times \exp\left\{-i\nu \frac{(x-x_0)}{\ell}\right\} dx_0 du_0 \\ &+ \frac{1}{4\pi\ell^2} \iint_{S_3} \ell_q^{(3)}(x_0,u_0;\nu,M) K_2\left(\frac{x-x_0}{\ell}, \frac{u_0}{\ell}, \frac{z}{\ell}, -\frac{1}{2}\pi - \alpha; \nu,M\right) \\ &\quad \times \exp\left\{-i\nu \frac{(x-x_0)}{\ell}\right\} dx_0 du_0 \\ &\dots\dots (2-17) \end{aligned}$$

$$\begin{aligned}
w_q^{(2)}(x, u; \nu) &= \frac{1}{4\pi\ell^2} \iint_{S_1} \ell_q^{(1)}(x_0, z_0; \nu, M) K_2\left(\frac{x-x_0}{\ell}, \frac{z_0}{\ell}, \frac{u}{\ell}, -\frac{1}{2}\pi - \alpha; \nu, M\right) \\
&\quad \times \exp\left\{-i\nu \frac{(x-x_0)}{\ell}\right\} dx_0 dz_0 \\
&+ \frac{1}{4\pi\ell^2} \iint_{S_2} \ell_q^{(2)}(x_0, u_0; \nu, M) K_1\left(\frac{x-x_0}{\ell}, \frac{u-u_0}{\ell}; \nu, M\right) \\
&\quad \times \exp\left\{-i\nu \frac{(x-x_0)}{\ell}\right\} dx_0 du_0 \\
&+ \frac{1}{4\pi\ell^2} \iint_{S_3} \ell_q^{(3)}(x_0, u_0; \nu, M) K_2\left(\frac{x-x_0}{\ell}, \frac{u_0}{\ell}, \frac{u}{\ell}, \pi - 2\alpha; \nu, M\right) \\
&\quad \times \exp\left\{-i\nu \frac{(x-x_0)}{\ell}\right\} dx_0 du_0 \\
&\dots\dots (2-18)
\end{aligned}$$

$$\begin{aligned}
w_q^{(3)}(x, u; \nu) &= \frac{1}{4\pi\ell^2} \iint_{S_1} \ell_q^{(1)}(x_0, z_0; \nu, M) K_2\left(\frac{x-x_0}{\ell}, \frac{z_0}{\ell}, \frac{u}{\ell}, \frac{1}{2}\pi + \alpha; \nu, M\right) \\
&\quad \times \exp\left\{-i\nu \frac{(x-x_0)}{\ell}\right\} dx_0 dz_0 \\
&+ \frac{1}{4\pi\ell^2} \iint_{S_2} \ell_q^{(2)}(x_0, u_0; \nu, M) K_2\left(\frac{x-x_0}{\ell}, \frac{u_0}{\ell}, \frac{u}{\ell}, -\pi + 2\alpha; \nu, M\right) \\
&\quad \times \exp\left\{-i\nu \frac{(x-x_0)}{\ell}\right\} dx_0 du_0 \\
&+ \frac{1}{4\pi\ell^2} \iint_{S_3} \ell_q^{(3)}(x_0, u_0; \nu, M) K_1\left(\frac{x-x_0}{\ell}, \frac{u-u_0}{\ell}; \nu, M\right) \\
&\quad \times \exp\left\{-i\nu \frac{(x-x_0)}{\ell}\right\} dx_0 du_0 \\
&\dots\dots (2-19)
\end{aligned}$$

where the kernel functions $K_1(x, y; v, M)$ and $K_2(x, u, v, \theta; v, M)$ are given, for subsonic flow $M < 1$, by the formulae

$$K_1(x, y; v, M) = \left[\int_{\frac{-x+MR}{\beta^2}}^{\infty} \exp(-iv\lambda) \frac{d\lambda}{(\lambda^2 + y^2)^{\frac{3}{2}}} + \frac{M(Mx + R)}{R(x^2 + y^2)} \exp\left(-iv \frac{(-x + MR)}{\beta^2}\right) \right] \quad \dots\dots (2-20)$$

$$K_2(x, u, v, \theta, v, M) = \cos \theta K_1\left(x, \sqrt{u^2 - 2uv \cos \theta + v^2}; v, M\right) - uv(\sin \theta)^2 F\left(x, \sqrt{u^2 - 2uv \cos \theta + v^2}; v, M\right) \quad \dots\dots (2-21)$$

with

$$F(x, y; v, M) = \left[3 \int_{\frac{-x+MR}{\beta^2}}^{\infty} \exp(-iv\lambda) \frac{d\lambda}{(\lambda^2 + y^2)^{\frac{3}{2}}} + \exp\left(-iv \frac{(-x + MR)}{\beta^2}\right) \left\{ \frac{M(Mx + R)^3}{R(x^2 + y^2)^3} + \frac{M^2 \beta^2 x}{R^3(x^2 + y^2)} + \frac{2M(Mx + R)}{R(x^2 + y^2)^2} + iv \frac{M^2(Mx + R)}{R^2(x^2 + y^2)} \right\} \right] \quad \dots\dots (2-22)$$

$$\beta^2 = 1 - M^2 \quad (2-23)$$

and

$$R = R(x, y, \beta) = \sqrt{x^2 + \beta^2 y^2} \quad (2-24)$$

We note that

$$K_2(x, u, v, -\theta; v, M) = K_2(x, u, v, \theta; v, M) \quad (2-25)$$

For analyses of dynamics of oscillating fin-tailplane configurations in an airstream we need to know the generalised airforce coefficients $Q_{pq}(\nu, M)$, $p = 1, 2, 3, \dots$, $q = 1, 2, 3, \dots$, which are given by the expression

$$\begin{aligned} Q_{pq}(\nu, M) &= \frac{1}{\ell^2} \iint_{S_1} f_p^{(1)}(x, z) \ell_q^{(1)}(x, z; \nu, M) dx dz \\ &+ \frac{1}{\ell^2} \iint_{S_2} f_p^{(2)}(x, u) \ell_q^{(2)}(x, u; \nu, M) dx du \\ &+ \frac{1}{\ell^2} \iint_{S_3} f_p^{(3)}(x, u) \ell_q^{(3)}(x, u; \nu, M) dx du \end{aligned} \quad (2-26)$$

in the linearised approximation. The main purpose of the present paper is to develop a method for evaluating numerically the quantities $Q_{p,q}(\nu, M)$.

2.2 Approximate solution of the integral equations

We introduce parametric coordinates on the surfaces S_1 , S_2 and S_3 as follows:

(i) On S_1

$$\xi_0 = \frac{1}{c_1(z_0)} \{x_0 - e_1(z_0)\} \quad (2-27)$$

$$\eta_0 = \frac{1}{s_1} z_0 \quad (2-28)$$

$$\xi = \frac{1}{c_1(z)} \{x - e_1(z)\} \quad (2-29)$$

$$\eta = \frac{1}{s_1} z \quad (2-30)$$

where s_1 is the span of the fin S_1 , $c_1(z)$ is the chord length and $e_1(z)$ is the x coordinate of the leading edge at spanwise position z .

(ii) On S_2

$$\xi_0 = \frac{1}{c_2(u_0)} \{x_0 - e_2(u_0)\} \quad (2-31)$$

$$\eta_0 = \frac{1}{s_2} u_0 \quad (2-32)$$

$$\xi = \frac{1}{c_2(u)} \{x - e_2(u)\} \quad (2-33)$$

$$\eta = \frac{1}{s_2} u \quad (2-34)$$

where s_2 is the span of the half-tailplane S_2 , $c_2(u)$ is the chord length and $e_2(u)$ is the x coordinate of the leading edge at spanwise position u .

(iii) On S_3

$$\xi_0 = \frac{1}{c_3(u_0)} \{x_0 - e_3(u_0)\} \quad (2-35)$$

$$\eta_0 = \frac{1}{s_3} u_0 \quad (2-36)$$

$$\xi = \frac{1}{c_3(u)} \{x - e_3(u)\} \quad (2-37)$$

$$\eta = \frac{1}{s_3} u \quad (2-38)$$

where s_3 is the span of the half-tailplane S_3 , $c_3(u)$ is the chord length and $e_3(u)$ is the x coordinate of the leading edge at spanwise position u .

Since the surfaces S_2 and S_3 are images of each other in the plane $y = 0$ we must have

$$e_3(u) = e_2(u) \quad (2-39)$$

$$c_3(u) = c_2(u) \quad (2-40)$$

and

$$s_3 = s_2 \quad (2-41)$$

The oscillation of the fin-tailplane configuration is taken to be anti-symmetric about the plane $y = 0$. If the oscillation were symmetric about the plane $y = 0$, then the fin S_1 would be at rest and the flow about the configuration would be symmetric. There would therefore be no aerodynamic loading on the fin and the presence of the fin would not affect the aerodynamic loadings on the half-tailplanes S_2 and S_3 . The fin-tailplane would therefore need to be treated in exactly the same way as an isolated wing with dihedral oscillating symmetrically. Because of the validity of the principle of superposition we then need to deal only with antisymmetric oscillations of the fin-tailplane.

Accordingly we have

$$w_q^{(3)}(x, u; v) = w_q^{(2)}(x, u; v) \quad (2-42)$$

and consequently

$$l_q^{(3)}(x_0, u_0; v, M) = l_q^{(2)}(x_0, u_0; v, M) \quad (2-43)$$

The triplet of integral equations (2-17) to (2-19) reduce to two independent ones because of the relations (2-25) and (2-39) to (2-43). The two independent integral equations may be written, on using parametric coordinates for the integration variables on the surfaces S_1 , S_2 and S_3 ,

$$\begin{aligned}
 w_q^{(1)}(x, z; \nu) &= \frac{s_1}{4\pi\ell} \int_0^1 \frac{c_1(z_0)}{\ell} d\eta_0 \int_0^1 \ell_q^{(1)}(x_0, z_0; \nu, M) K_1\left(\frac{x-x_0}{\ell}, \frac{z-z_0}{\ell}; \nu, M\right) \\
 &\quad \times \exp\left\{-i\nu\left(\frac{x-x_0}{\ell}\right)\right\} d\xi_0 \\
 &+ \frac{s_2}{2\pi\ell} \int_0^1 \frac{c_2(u_0)}{\ell} d\eta_0 \int_0^1 \ell_q^{(2)}(x_0, u_0; \nu, M) K_2\left(\frac{x-x_0}{\ell}, \frac{u_0}{\ell}, \frac{z}{\ell}, \frac{1}{2}\pi + \alpha; \nu, M\right) \\
 &\quad \times \exp\left\{-i\nu\left(\frac{x-x_0}{\ell}\right)\right\} d\xi_0 \\
 &\dots\dots (2-44)
 \end{aligned}$$

$$\begin{aligned}
 w_q^{(2)}(x, u; \nu) &= \frac{s_1}{4\pi\ell} \int_0^1 \frac{c_1(z_0)}{\ell} d\eta_0 \int_0^1 \ell_q^{(1)}(x_0, z_0; \nu, M) K_2\left(\frac{x-x_0}{\ell}, \frac{z_0}{\ell}, \frac{u}{\ell}, \frac{1}{2}\pi + \alpha; \nu, M\right) \\
 &\quad \times \exp\left\{-i\nu\left(\frac{x-x_0}{\ell}\right)\right\} d\xi_0 \\
 &+ \frac{s_2}{4\pi\ell} \int_0^1 \frac{c_2(u_0)}{\ell} d\eta_0 \int_0^1 \ell_q^{(2)}(x_0, u_0; \nu, M) K_1\left(\frac{x-x_0}{\ell}, \frac{u-u_0}{\ell}; \nu, M\right) \\
 &\quad \times \exp\left\{-i\nu\left(\frac{x-x_0}{\ell}\right)\right\} d\xi_0 \\
 &+ \frac{s_2}{4\pi\ell} \int_0^1 \frac{c_2(u_0)}{\ell} d\eta_0 \int_0^1 \ell_q^{(2)}(x_0, u_0; \nu, M) K_2\left(\frac{x-x_0}{\ell}, \frac{u_0}{\ell}, \frac{u}{\ell}, \pi - 2\alpha; \nu, M\right) \\
 &\quad \times \exp\left\{-i\nu\left(\frac{x-x_0}{\ell}\right)\right\} d\xi_0 . \\
 &\dots\dots (2-45)
 \end{aligned}$$

The loading functions $\lambda_q^{(1)}(x_0, z_0; \nu, M)$, $\lambda_q^{(2)}(x_0, u_0; \nu, M)$ and $\lambda_q^{(3)}(x_0, u_0; \nu, M)$ satisfy the junction condition

$$\lambda_q^{(1)}(x_0, 0; \nu, M) + \lambda_q^{(2)}(x_0, 0; \nu, M) + \lambda_q^{(3)}(x_0, 0; \nu, M) = 0 \quad (2-46)$$

which, in virtue of (2-43), may be replaced by

$$\lambda_q^{(1)}(x_0, 0; \nu, M) + 2\lambda_q^{(2)}(x_0, 0; \nu, M) = 0 \quad (2-47)$$

We wish to solve the pair of integral equations (2-44) and (2-45) when the normal velocity functions $w_q^{(1)}(x, z; \nu)$ and $w_q^{(2)}(x, u; \nu)$ are known for loading functions $\lambda_q^{(1)}(x_0, z_0; \nu, M)$ and $\lambda_q^{(2)}(x_0, u_0; \nu, M)$ that satisfy the condition (2-47) and then to use these loading functions for the calculation of $Q_{p,q}(\nu, M)$ from formula (2-26). The integral equations (2-44) and (2-45) do not have a unique solution for $\lambda_q^{(1)}(x_0, z_0; \nu, M)$ and $\lambda_q^{(2)}(x_0, u_0; \nu, M)$, unless we impose the condition that these latter two functions vanish at the trailing edges of S_1 and S_2 respectively.

Let

$$\xi_k^{(n)}, \quad k = 1(1)n, \quad (2-48)$$

be n points ξ_0 in $(0, 1)$ and let

$$\eta_j^{(m)}, \quad j = 1(1)m, \quad (2-49)$$

be m points η_0 in $(0, 1)$ of which

$$\eta_1^{(m)} = 0 \quad (2-50)$$

We form the interpolation polynomials $h_r^{(n)}(\xi_0)$, $r = 1(1)n$, each of degree $(n - 1)$ in ξ_0 and the interpolation polynomials $g_s^{(m)}(\eta_0)$, $s = 1(1)m$, each of degree $(m - 1)$ in η_0 by means of the formulae

$$h_r^{(n)}(\xi_0) = \prod_{\substack{k=1 \\ k \neq r}}^n \left(\frac{\xi_0 - \xi_k^{(n)}}{\xi_r^{(n)} - \xi_k^{(n)}} \right), \quad r = 1(1)n, \quad (2-51)$$

and

$$g_s^{(m)}(\eta_0) = \prod_{\substack{j=1 \\ j \neq s}}^m \left(\frac{\eta_0 - \eta_j^{(m)}}{\eta_s^{(m)} - \eta_j^{(m)}} \right), \quad s = 1(1)m, \quad (2-52)$$

These interpolation polynomials have the properties

$$h_r^{(n)}(\xi_k^{(n)}) = \delta_{rk}, \quad \left. \begin{array}{l} r = 1(1)n \\ k = 1(1)n \end{array} \right\} \quad (2-53)$$

and

$$g_s^{(m)}(\eta_j^{(m)}) = \delta_{sj}, \quad \left. \begin{array}{l} s = 1(1)m \\ j = 1(1)m \end{array} \right\} \quad (2-54)$$

where δ_{rk} is the Kronecker delta

$$\delta_{rk} = \begin{cases} 1 & r = k \\ 0 & r \neq k \end{cases} \quad (2-55)$$

We take an approximation $\hat{\ell}_q^{(1)}(x_0, z_0)$ to $\ell_q^{(1)}(x_0, z_0; \nu, M)$ by means of the formula

$$\hat{\ell}_q^{(1)}(x_0, z_0) = \frac{\ell}{c_1(z_0)} \exp\left(-\frac{i\nu x_0}{\ell}\right) \sum_{r=1}^n \sum_{s=1}^{m_1} A_{q;r,s}^{(1)} h_r^{(n)}(\xi_0) g_s^{(m_1)}(\eta_0) \sqrt{\frac{1-\xi_0}{\xi_0}} \sqrt{1-\eta_0} \quad \dots\dots (2-56)$$

and an approximation $\hat{\ell}_q^{(2)}(x_0, u_0)$ to $\ell_q^{(2)}(x_0, u_0; \nu, M)$ by means of the formula

$$\hat{\ell}_q^{(2)}(x_0, u_0) = \frac{\ell}{c_2(u_0)} \exp\left(-\frac{i\nu x_0}{\ell}\right) \sum_{r=1}^n \sum_{s=1}^{m_2} A_{q;r,s}^{(2)} h_r^{(n)}(\xi_0) g_s^{(m_2)}(\eta_0) \sqrt{\frac{1-\xi_0}{\xi_0}} \sqrt{1-\eta_0} \quad \dots\dots (2-57)$$

The approximation $\hat{\ell}_q^{(1)}(x_0, z_0)$ to $\ell_q^{(1)}(x_0, z_0; \nu, M)$ vanishes at the trailing edge of the fin S_1 and it has the correct singular behaviour near the outer edges of S_1 except in the neighbourhood of corners where there are weak singularities not accounted for. Similarly the approximation $\hat{\ell}_q^{(2)}(x_0, u_0)$ to $\ell_q^{(2)}(x_0, u_0; \nu, M)$ vanishes at the trailing edge of the tailplane S_2 and it has

the correct singular behaviour near the outer edges except for weak corner singularities. The correct behaviour of $\ell_q^{(1)}(x_0, z_0; \nu, M)$ and $\ell_q^{(2)}(x_0, u_0; \nu, M)$ near the junction of the fin and tailplanes is not reproduced, but the singularity not accounted for is weak. Because the chords of the fin and tailplane have been taken equal in length to each other and coincident at the junction no stronger singularities in the loadings arise near the junction.

The coefficients $A_{q;r,s}^{(1)}$, $r = 1(1)n$, $s = 1(1)m_1$, and $A_{q;r,s}^{(2)}$, $r = 1(1)n$, $s = 1(1)m_2$, are to be determined so that $\hat{\ell}_q^{(1)}(x_0, z_0)$ and $\hat{\ell}_q^{(2)}(x_0, u_0)$ are good approximations, in some sense, to $\ell_q^{(1)}(x_0, z_0; \nu, M)$ and $\ell_q^{(2)}(x_0, u_0; \nu, M)$ respectively. In the first place, however, we shall need to satisfy a junction condition of the form (2-47), i.e.

$$\hat{\ell}_q^{(1)}(x_0, 0) + 2\hat{\ell}_q^{(2)}(x_0, 0) = 0, \quad (2-58)$$

which can be satisfied with the expressions (2-56) and (2-57) if we put

$$A_{q;r,1}^{(1)} + 2A_{q;r,1}^{(2)} = 0, \quad r = 1(1)n. \quad (2-59)$$

It was for the purpose of satisfying the condition (2-58) at all points along the junction chord that the same value of n was taken in the expressions (2-56) and (2-57) for $\hat{\ell}_q^{(1)}(x_0, z_0)$ and $\hat{\ell}_q^{(2)}(x_0, u_0)$ respectively and the value $\eta_1^{(m)}$ was taken to be zero in condition (2-50).

The choice of location of the points $\xi_r^{(n)}$, $r = 1(1)n$, and the points $\eta_s^{(m)}$, $s = 1(1)m$, is somewhat arbitrary. In this Report we choose the $\xi_r^{(n)}$, $r = 1(1)n$, to be the zeros of a polynomial $\ell_n(\xi_0)$ of degree n in ξ_0 which is such that

$$\int_0^1 \xi_0^{k-1} \ell_n(\xi_0) \sqrt{\frac{1-\xi_0}{\xi_0}} d\xi_0 = 0, \quad k = 1(1)n, \quad (2-60)$$

and we choose the $\eta_s^{(m)}$, $s = 2(1)m$, to be the zeros of a polynomial $\gamma_{m-1}(\eta_0)$ of degree $m-1$ in η_0 which is such that

$$\int_0^1 \eta_0^{j-1} \gamma_{m-1}(\eta_0) \sqrt{1-\eta_0} d\eta_0 = 0, \quad j = 2(1)m. \quad (2-61)$$

The interpolation polynomials $h_r^{(n)}(\xi_0)$, $r = 1(1)n$, and the interpolation polynomials $g_s^{(m)}(\eta_0)$, $s = 1(1)m$, defined above, then have very convenient properties for our subsequent analysis where integrals involving these polynomials occur. These properties are that, for arbitrary functions $f(\xi_0)$ and $k(\eta_0)$,

$$\int_0^1 f(\xi_0) h_r^{(n)}(\xi_0) \sqrt{\frac{1-\xi_0}{\xi_0}} d\xi_0 \simeq H_r^{(n)} f\left(\xi_r^{(n)}\right), \quad (2-62)$$

$r = 1(1)n,$

where

$$H_r^{(n)} = \int_0^1 h_r^{(n)}(\xi_0) \sqrt{\frac{1-\xi_0}{\xi_0}} d\xi_0, \quad r = 1(1)n, \quad (2-63)$$

and

$$\int_0^1 k(\eta_0) g_s^{(m)}(\eta_0) \sqrt{1-\eta_0} d\eta_0 \simeq G_s^{(m)} k\left(\eta_s^{(m)}\right), \quad (2-64)$$

$s = 1(1)m,$

where

$$G_s^{(m)} = \int_0^1 g_s^{(m)}(\eta_0) \sqrt{1-\eta_0} d\eta_0, \quad s = 1(1)m. \quad (2-65)$$

The approximate formula (2-62) becomes precise when $f(\xi_0)$ is a polynomial of degree $\leq n$ in ξ_0 and the approximate formula (2-64) becomes precise when $k(\eta_0)$ is a polynomial of degree $\leq m$ in η_0 .

In Ref 11 and elsewhere it is shown that

$$\xi_r^{(n)} = \frac{1}{2} \left[1 - \cos \left(\frac{2r-1}{2n+1} \pi \right) \right] \quad r = 1(1)n, \quad (2-66)$$

and that

$$H_r^{(n)} = \frac{2\pi}{2n+1} \left(1 - \xi_r^{(n)} \right), \quad r = 1(1)n. \quad (2-67)$$

No explicit analytical formulae are available for the points $\eta_s^{(m)}$, $s = 2(1)m$, and the integration weights $G_s^{(m)}$, $s = 1(1)m$, but we show in Appendix A how these values may be evaluated numerically.

If we substitute from (2-56) and (2-57), the approximations $\hat{l}_q^{(1)}(x_0, z_0)$ and $\hat{l}_q^{(2)}(x_0, u_0)$ to $l_q^{(1)}(x_0, z_0; \nu, M)$ and $l_q^{(2)}(x_0, u_0; \nu, M)$ respectively, into

the integral equations (2-44) and (2-45), we get approximations $\hat{w}_q^{(1)}(x, z)$ and $\hat{w}_q^{(2)}(x, u)$ to $w_q^{(1)}(x, z; \nu)$ and $w_q^{(2)}(x, u; \nu)$ that are given by

$$\begin{aligned} \hat{w}_q^{(1)}(x, z) &= \frac{1}{4\pi} \exp\left(-\frac{i\nu x}{l}\right) \sum_{r=1}^n \sum_{s=1}^{m_1} A_{q;r,s}^{(1)} w_{r,s}^{(1,1)}(x, z; \nu, M) \\ &+ \frac{1}{2\pi} \exp\left(-\frac{i\nu x}{l}\right) \sum_{r=1}^n \sum_{s=1}^{m_2} A_{q;r,s}^{(2)} w_{r,s}^{(1,2)}(x, z; \nu, M) \end{aligned} \quad (2-68)$$

and

$$\begin{aligned} \hat{w}_q^{(2)}(x, u) &= \frac{1}{4\pi} \exp\left(-\frac{i\nu x}{l}\right) \sum_{r=1}^n \sum_{s=1}^{m_1} A_{q;r,s}^{(1)} w_{r,s}^{(2,1)}(x, u; \nu, M) \\ &+ \frac{1}{4\pi} \exp\left(-\frac{i\nu x}{l}\right) \sum_{r=1}^n \sum_{s=1}^{m_2} A_{q;r,s}^{(2)} \left\{ w_{r,s}^{(2,2)}(x, u; \nu, M) + w_{r,s}^{(2,3)}(x, u; \nu, M) \right\} \end{aligned} \quad \dots\dots (2-69)$$

where

$$\begin{aligned} w_{r,s}^{(1,1)}(x, z; \nu, M) &= \frac{s_1}{l} \int_0^1 g_s^{(m_1)}(\eta_0) \sqrt{1-\eta_0} \, d\eta_0 \\ &\times \int_0^1 h_r^{(n)}(\xi_0) K_1\left(\frac{x-x_0}{l}, \frac{z-z_0}{l}; \nu, M\right) \sqrt{\frac{1-\xi_0}{\xi_0}} \, d\xi_0 \end{aligned} \quad (2-70)$$

$$\begin{cases} r = 1(1)n \\ s = 1(1)m_1 \end{cases}$$

$$\begin{aligned} w_{r,s}^{(1,2)}(x, z; \nu, M) &= \frac{s_2}{l} \int_0^1 g_s^{(m_2)}(\eta_0) \sqrt{1-\eta_0} \, d\eta_0 \\ &\times \int_0^1 h_r^{(n)}(\xi_0) K_2\left(\frac{x-x_0}{l}, \frac{u_0}{l}, \frac{z}{l}, \frac{1}{2}\pi + \alpha; \nu, M\right) \sqrt{\frac{1-\xi_0}{\xi_0}} \, d\xi_0 \end{aligned} \quad (2-71)$$

$$\begin{cases} r = 1(1)n \\ s = 1(1)m_2 \end{cases}$$

$$w_{r,s}^{(2,1)}(x,u;v,M) = \frac{s_1}{l} \int_0^1 g_s^{(m_1)}(\eta_0) \sqrt{1-\eta_0} d\eta_0$$

$$\times \int_0^1 h_r^{(n)}(\xi_0) K_2\left(\frac{x-x_0}{l}, \frac{z_0}{l}, \frac{u}{l}, \frac{1}{2}\pi + \alpha; v, M\right) \sqrt{\frac{1-\xi_0}{\xi_0}} d\xi_0 \quad (2-72)$$

$$\begin{cases} r = 1(1)n \\ s = 1(1)m_1 \end{cases}$$

$$w_{r,s}^{(2,2)}(x,u;v,M) = \frac{s_2}{l} \int_0^1 g_s^{(m_2)}(\eta_0) \sqrt{1-\eta_0} d\eta_0$$

$$\times \int_0^1 h_r^{(n)}(\xi_0) K_1\left(\frac{x-x_0}{l}, \frac{u-u_0}{l}; v, M\right) \sqrt{\frac{1-\xi_0}{\xi_0}} d\xi_0 \quad (2-73)$$

$$\begin{cases} r = 1(1)n \\ s = 1(1)m_2 \end{cases}$$

and

$$w_{r,s}^{(2,3)}(x,u;v,M) = \frac{s_2}{l} \int_0^1 g_s^{(m_2)}(\eta_0) \sqrt{1-\eta_0} d\eta_0$$

$$\times \int_0^1 h_r^{(n)}(\xi_0) K_2\left(\frac{x-x_0}{l}, \frac{u_0}{l}, \frac{u}{l}, \pi - 2\alpha; v, M\right) \sqrt{\frac{1-\xi_0}{\xi_0}} d\xi_0 \quad (2-74)$$

$$\begin{cases} r = 1(1)n \\ s = 1(1)m_2 \end{cases}$$

For the purpose of developing an approximation formula for the generalised airforce coefficients $Q_{p,q}(v,M)$, $p = 1, 2, 3, \dots$, $q = 1, 2, 3, \dots$, given by the expression (2-26) we introduce the two integral equations

$$f_p^{(1)}(x_0, z_0) = \frac{s_1}{4\pi l} \int_0^1 \frac{c_1(z)}{l} d\eta \int_0^1 \bar{\xi}_p^{(1)}(x, z; v, M) K_1\left(\frac{x-x_0}{l}, \frac{z_0-z}{l}; v, M\right)$$

$$\times \exp\left\{-iv\left(\frac{x-x_0}{l}\right)\right\} d\xi$$

$$+ \frac{s_2}{2\pi l} \int_0^1 \frac{c_2(u)}{l} d\eta \int_0^1 \bar{\xi}_p^{(2)}(x, u; v, M) K_2\left(\frac{x-x_0}{l}, \frac{u}{l}, \frac{z_0}{l}, \frac{1}{2}\pi + \alpha; v, M\right)$$

$$\times \exp\left\{-iv\left(\frac{x-x_0}{l}\right)\right\} d\xi \quad (2-75)$$

$$\begin{aligned}
f_p^{(2)}(x_0, u_0) &= \frac{s_1}{4\pi l} \int_0^1 \frac{c_1(z)}{l} d\eta \int_0^1 \bar{l}_p^{(1)}(x, z; \nu, M) K_2\left(\frac{x-x_0}{l}, \frac{z}{l}, \frac{u_0}{l}, \frac{1}{2}\pi + \alpha; \nu, M\right) \\
&\quad \times \exp\left\{-i\nu\left(\frac{x-x_0}{l}\right)\right\} d\xi \\
&+ \frac{s_2}{4\pi l} \int_0^1 \frac{c_2(u)}{l} d\eta \int_0^1 \bar{l}_p^{(2)}(x, u; \nu, M) K_1\left(\frac{x-x_0}{l}, \frac{u_0-u}{l}; \nu, M\right) \\
&\quad \times \exp\left\{-i\nu\left(\frac{x-x_0}{l}\right)\right\} d\xi \\
&+ \frac{s_2}{4\pi l} \int_0^1 \frac{c_2(u)}{l} d\eta \int_0^1 \bar{l}_p^{(2)}(x, u; \nu, M) K_2\left(\frac{x-x_0}{l}, \frac{u}{l}, \frac{u_0}{l}, \pi - 2\alpha; \nu, M\right) \\
&\quad \times \exp\left\{-i\nu\left(\frac{x-x_0}{l}\right)\right\} d\xi . \quad (2-76)
\end{aligned}$$

The unknowns $\bar{l}_p^{(1)}(x, z; \nu, M)$ and $\bar{l}_p^{(2)}(x, u; \nu, M)$ are loading functions on the fin surface S_1 and tailplane surface S_2 when the fin-tailplane configuration is in antisymmetric harmonic oscillation in a main stream of speed V in the direction of the negative x -axis, the oscillation being such that the scaled normal air velocities on the surfaces S_1 , S_2 and S_3 are the modal functions $f_p^{(1)}(x_0, z_0)$, $f_p^{(2)}(x_0, u_0)$ and $f_p^{(3)}(x_0, u_0)$ with

$$f_p^{(3)}(x_0, u_0) = f_p^{(2)}(x_0, u_0) . \quad (2-77)$$

However, as far as we are concerned, the unknowns $\bar{l}_p^{(1)}(x, z; \nu, M)$ and $\bar{l}_p^{(2)}(x, u; \nu, M)$ are merely solutions of the pair of integral equations (2-75) and (2-76) upon which we impose the junction condition

$$\bar{l}_p^{(1)}(x, 0; \nu, M) + 2\bar{l}_p^{(2)}(x, 0; \nu, M) = 0 \quad (2-78)$$

which is analogous to the junction condition (2-47), and appropriate behaviours near the edges of S_1 and S_2 .

We take an approximation $\hat{l}_p^{(1)}(x, z)$ to $\bar{l}_p^{(1)}(x, z; \nu, M)$ by means of the formula

$$\hat{\ell}_p^{(1)}(x,z) = \frac{\ell}{c_1(z)} \exp\left(\frac{i\nu x}{\ell}\right) \sum_{i=1}^n \sum_{j=1}^{m_1} \bar{A}_{p;i,j}^{(1)} h_i^{(n)}(1-\xi) g_j^{(m_1)}(\eta) \sqrt{\frac{\xi}{1-\xi}} \sqrt{1-\eta} \dots\dots (2-79)$$

and an approximation $\hat{\ell}_p^{(2)}(x,u)$ to $\bar{\ell}_p^{(2)}(x,u;\nu,M)$ by means of the formula

$$\hat{\ell}_p^{(2)}(x,u) = \frac{\ell}{c_2(u)} \exp\left(\frac{i\nu x}{\ell}\right) \sum_{i=1}^n \sum_{j=1}^{m_2} \bar{A}_{p;i,j}^{(2)} h_i^{(n)}(1-\xi) g_j^{(m_2)}(\eta) \sqrt{\frac{\xi}{1-\xi}} \sqrt{1-\eta} \dots\dots (2-80)$$

The approximations $\hat{\ell}_p^{(1)}(x,z)$ to $\bar{\ell}_p^{(1)}(x,z;\nu,M)$ and $\hat{\ell}_p^{(2)}(x,u)$ to $\bar{\ell}_p^{(2)}(x,u;\nu,M)$ have the appropriate behaviours near the edges of S_1 and S_2 . We shall require $\hat{\ell}_p^{(1)}(x,z)$ and $\hat{\ell}_p^{(2)}(x,u)$ to satisfy a junction condition of the form (2-78), *ie*

$$\hat{\ell}_p^{(1)}(x,0) + 2\hat{\ell}_p^{(2)}(x,0) = 0 \quad (2-81)$$

We can satisfy this condition with the expressions (2-79) and (2-80) for $\hat{\ell}_p^{(1)}(x,z)$ and $\hat{\ell}_p^{(2)}(x,u)$ respectively if we put

$$\bar{A}_{p;i,l}^{(1)} + 2\bar{A}_{p;i,l}^{(2)} = 0, \quad i=1(1)n \quad (2-82)$$

If we substitute the approximations $\hat{\ell}_p^{(1)}(x,z)$ and $\hat{\ell}_p^{(2)}(x,u)$ to $\bar{\ell}_p^{(1)}(x,z;\nu,M)$ and $\bar{\ell}_p^{(2)}(x,u;\nu,M)$ respectively, into the right-hand sides of the integral equations (2-75) and (2-76), we shall get approximations $\hat{f}_p^{(1)}(x_0,z_0)$ and $\hat{f}_p^{(2)}(x_0,u_0)$ to $f_p^{(1)}(x_0,z_0)$ and $f_p^{(2)}(x_0,u_0)$ respectively.

If we introduce the antisymmetry conditions (2-43) and (2-77) into the formula (2-26) for $Q_{pq}(\nu,M)$ we get

$$Q_{pq}(\nu,M_\infty) = \frac{1}{\ell^2} \iint_{S_1} f_p^{(1)}(x,z) \ell_q^{(1)}(x,z;\nu,M) dx dz + \frac{2}{\ell^2} \iint_{S_2} f_p^{(2)}(x,u) \ell_q^{(2)}(x,u;\nu,M) dx du \quad (2-83)$$

We take an approximation \hat{Q}_{pq} to $Q_{pq}(v, M)$ by means of the formula

$$\begin{aligned} \hat{Q}_{pq} &= \frac{1}{\ell^2} \iint_{S_1} \left\{ \hat{\ell}_p^{(1)}(x, z) w_q^{(1)}(x, z; v) + f_p^{(1)}(x, z) \hat{\ell}_q^{(1)}(x, z) - \hat{\ell}_p^{(1)}(x, z) \hat{w}_q^{(1)}(x, z) \right\} dx dz \\ &+ \frac{2}{\ell^2} \iint_{S_2} \left\{ \hat{\ell}_p^{(2)}(x, u) w_q^{(2)}(x, u; v) + f_p^{(2)}(x, u) \hat{\ell}_q^{(2)}(x, u) - \hat{\ell}_p^{(2)}(x, u) \hat{w}_q^{(2)}(x, u) \right\} dx du . \end{aligned}$$

..... (2-84)

Now we can show that the relation

$$\begin{aligned} &\frac{1}{\ell^2} \iint_{S_1} \hat{\ell}_p^{(1)}(x, z) w_q^{(1)}(x, z; v) dx dz + \frac{2}{\ell^2} \iint_{S_2} \hat{\ell}_p^{(2)}(x, u) w_q^{(2)}(x, u; v) dx du \\ &= \frac{1}{\ell^2} \iint_{S_2} \hat{f}_p^{(1)}(x_0, z_0) \ell_q^{(1)}(x_0, z_0; v, M) dx_0 dz_0 + \frac{2}{\ell^2} \iint_{S_2} \hat{f}_p^{(2)}(x_0, u_0) \ell_q^{(2)}(x_0, u_0; v, M) dx_0 du_0 \end{aligned}$$

..... (2-85)

is true merely by substituting for $w_q^{(1)}(x, z; v)$ and $w_q^{(2)}(x, u; v)$ from the integral equations (2-44) and (2-45) respectively into the left-hand side of (2-85) changing the order of integration and then using the integral equations analogous to (2-75) and (2-76) to recover $\hat{f}_p^{(1)}(x_0, z_0)$ and $\hat{f}_p^{(2)}(x_0, u_0)$ respectively. Similarly we can show that the relation

$$\begin{aligned} &\frac{1}{\ell^2} \iint_{S_1} \hat{\ell}_p^{(1)}(x, z) \hat{w}_q^{(1)}(x, z) dx dz + \frac{2}{\ell^2} \iint_{S_2} \hat{\ell}_p^{(2)}(x, u) \hat{w}_q^{(2)}(x, u) dx du \\ &= \frac{1}{\ell^2} \iint_{S_1} \hat{f}_p^{(1)}(x_0, z_0) \hat{\ell}_q^{(1)}(x_0, z_0) dx_0 dz_0 + \frac{2}{\ell^2} \iint_{S_2} \hat{f}_p^{(2)}(x_0, u_0) \hat{\ell}_q^{(2)}(x_0, u_0) dx_0 du_0 \end{aligned}$$

..... (2-86)

is true merely by substituting for $\hat{w}_q^{(1)}(x, z)$ and $\hat{w}_q^{(2)}(x, u)$ from the integral equations analogous to (2-44) and (2-45) respectively into the left-hand side of (2-86) changing the order of integration and then using the integral equations analogous to (2-75) and (2-76) to recover $\hat{f}_p^{(1)}(x_0, z_0)$ and $\hat{f}_p^{(2)}(x_0, u_0)$

respectively. Both relations (2-85) and (2-86) are expressions of Flax's reverse flow theorem^{2,3} for fin-tailplane configurations.

By using the relations (2-85) and (2-86) we can rewrite the formula (2-84) for $\hat{Q}_{p,q}$ as

$$\begin{aligned} \hat{Q}_{p,q} = & \frac{1}{\ell^2} \iint_{S_1} \left\{ \hat{f}_p^{(1)}(x,z) \ell_q^{(1)}(x,z;v) + f_p^{(1)}(x,z) \hat{\ell}_q^{(1)}(x,z) - \hat{f}_p^{(1)}(x,z) \hat{\ell}_q^{(1)}(x,z) \right\} dx dz \\ & + \frac{2}{\ell^2} \iint_{S_2} \left\{ \hat{f}_p^{(2)}(x,u) \ell_q^{(2)}(x,u;v) + f_p^{(2)}(x,u) \hat{\ell}_q^{(2)}(x,u) - \hat{f}_p^{(2)}(x,u) \hat{\ell}_q^{(2)}(x,u) \right\} dx du. \end{aligned} \quad \dots\dots (2-87)$$

Let us put

$$\delta \ell_q^{(1)}(x,z) = \hat{\ell}_q^{(1)}(x,z) - \ell_q^{(1)}(x,z;v, M_\infty) \quad (2-88)$$

$$\delta \ell_q^{(2)}(x,u) = \hat{\ell}_q^{(2)}(x,u) - \ell_q^{(2)}(x,u;v, M_\infty) \quad (2-89)$$

$$\delta f_p^{(1)}(x,z) = \hat{f}_p^{(1)}(x,z) - f_p^{(1)}(x,z) \quad (2-90)$$

$$\delta f_p^{(2)}(x,u) = \hat{f}_p^{(2)}(x,u) - f_p^{(2)}(x,u) \quad (2-91)$$

Then formula (2-87) may be replaced by

$$\begin{aligned} \hat{Q}_{pq} = & Q_{pq}(v, M) - \frac{1}{\ell^2} \iint_{S_1} \delta f_p^{(1)}(x,z) \delta \ell_q^{(1)}(x,z) dx dz \\ & - \frac{2}{\ell^2} \iint_{S_2} \delta f_p^{(2)}(x,u) \delta \ell_q^{(2)}(x,u) dx du \quad (2-92) \end{aligned}$$

From formula (2-92) we see that \hat{Q}_{pq} differs from $Q_{pq}(v, M)$ by a quantity which is of the second degree. If $\hat{f}_p^{(1)}(x,z)$ and $\hat{f}_p^{(2)}(x,u)$ were exactly equal to $f_p^{(1)}(x,z)$ and $f_p^{(2)}(x,z)$ respectively then \hat{Q}_{pq} would be exactly equal to $Q_{pq}(v, M)$ regardless of the accuracy of $\hat{\ell}_q^{(1)}(x,z)$ and $\hat{\ell}_q^{(2)}(x,u)$. Equally if $\hat{\ell}_q^{(1)}(x,z)$ and $\hat{\ell}_q^{(2)}(x,u)$ were exactly equal to

$\lambda_q^{(1)}(x,z;v,M)$ and $\lambda_q^{(2)}(x,u;v,M)$ respectively then again \hat{Q}_{pq} would be exactly equal to $Q_{pq}(v,M)$ regardless of the accuracy of $f_p^{(1)}(x,z)$ and $f_p^{(2)}(x,u)$. These exactitudes are not likely to arise. However, it is possible to choose the coefficients $A_{q;r,s}^{(1)}$, $A_{q;r,s}^{(2)}$, $\bar{A}_{p;i,j}^{(1)}$ and $\bar{A}_{p;i,j}^{(2)}$, in the respective formulae (2-56), (2-57), (2-79) and (2-80) so that the corresponding value of \hat{Q}_{pq} is stationary for variations of these coefficients from the chosen values, with the conditions (2-59) and (2-82) being satisfied. It is this stationary value of \hat{Q}_{pq} that will be taken as the approximation to $Q_{pq}(v,M)$ in this work. The approximate loading functions $\hat{\lambda}_q^{(1)}(x_0,z_0)$ and $\hat{\lambda}_q^{(2)}(x_0,u_0)$ are taken to be good approximations to $\lambda_q^{(1)}(x_0,z_0;v,M)$ and $\lambda_q^{(2)}(x_0,u_0;v,M)$ respectively if the quantities \hat{Q}_{pq} are good approximations to $Q_{pq}(v,M)$ for all p and q . This is an application of Flax's variational principle² to fin-tailplane configurations.

If we introduce the formulae (2-56), (2-57), (2-68), (2-69), (2-79) and (2-80) for $\hat{\lambda}_q^{(1)}(x,z)$, $\hat{\lambda}_q^{(2)}(x,u)$, $\hat{w}_q^{(1)}(x,z)$, $\hat{w}_q^{(2)}(x,u)$, $\hat{\lambda}_p^{(1)}(x,z)$ and $\hat{\lambda}_p^{(2)}(x,u)$ respectively into the right-hand side of formula (2-84) and use the parametric coordinates (2-29) and (2-30) on the surface S_1 and the parametric coordinates (2-33) and (2-34) on the surface S_2 we get

$$\begin{aligned} \hat{Q}_{pq} = & \sum_{i=1}^n \sum_{j=1}^{m_1} \bar{A}_{p;i,j}^{(1)} \theta_{q;i,j}^{(1)} + \sum_{i=1}^n \sum_{j=1}^{m_2} 2\bar{A}_{p;i,j}^{(2)} \theta_{q;i,j}^{(2)} \\ & + \sum_{r=1}^n \sum_{s=1}^{m_1} A_{q;r,s}^{(1)} \phi_{p;r,s}^{(1)} + \sum_{r=1}^n \sum_{s=1}^{m_2} 2A_{q;r,s}^{(2)} \phi_{p;r,s}^{(2)} \\ & - \sum_{i=1}^n \sum_{j=1}^{m_1} \sum_{r=1}^n \sum_{s=1}^{m_1} \bar{A}_{p;i,j}^{(1)} A_{q;r,s}^{(1)} \psi_{i,j;r,s}^{(1,1)} \\ & - \sum_{i=1}^n \sum_{j=1}^{m_1} \sum_{r=1}^n \sum_{s=1}^{m_2} 2\bar{A}_{p;i,j}^{(1)} A_{q;r,s}^{(2)} \psi_{i,j;r,s}^{(1,2)} \end{aligned}$$

$$\begin{aligned}
& - \sum_{i=1}^n \sum_{j=1}^{m_2} \sum_{r=1}^n \sum_{s=1}^{m_1} 2\bar{A}_{p;i,j}^{(2)} A_{q;r,s}^{(1)} \psi_{i,j;r,s}^{(2,1)} \\
& - \sum_{i=1}^n \sum_{j=1}^{m_2} \sum_{r=1}^n \sum_{s=1}^{m_2} 2\bar{A}_{p;i,j}^{(2)} A_{q;r,s}^{(2)} \left\{ \psi_{i,j;r,s}^{(2,2)} + \psi_{i,j;r,s}^{(2,3)} \right\} \quad (2-93)
\end{aligned}$$

where

$$\begin{aligned}
\theta_{q;i,j}^{(1)} &= \frac{s_1}{\ell} \int_0^1 g_j^{(m_1)}(\eta) \sqrt{1-\eta} \, d\eta \int_0^1 h_i^{(n)}(1-\xi) \sqrt{\frac{\xi}{1-\xi}} w_q^{(1)}(x,z;\nu) \exp\left(\frac{i\nu x}{\ell}\right) d\xi \\
& \quad i=1(1)n, \quad j=1(1)m_1, \quad (2-94)
\end{aligned}$$

$$\begin{aligned}
\theta_{q;i,j}^{(2)} &= \frac{s_2}{\ell} \int_0^1 g_j^{(m_2)}(\eta) \sqrt{1-\eta} \, d\eta \int_0^1 h_i^{(n)}(1-\xi) \sqrt{\frac{\xi}{1-\xi}} w_q^{(2)}(x,u;\nu) \exp\left(\frac{i\nu x}{\ell}\right) d\xi \\
& \quad i=1(1)n, \quad j=1(1)m_2, \quad (2-95)
\end{aligned}$$

$$\begin{aligned}
\phi_{p;r,s}^{(1)} &= \frac{s_1}{\ell} \int_0^1 g_s^{(m_1)}(\eta) \sqrt{1-\eta} \, d\eta \int_0^1 h_r^{(n)}(\xi) \sqrt{\frac{1-\xi}{\xi}} f_p^{(1)}(x,z) \exp\left(-\frac{i\nu x}{\ell}\right) d\xi \\
& \quad r=1(1)n, \quad s=1(1)m_1, \quad (2-96)
\end{aligned}$$

$$\begin{aligned}
\phi_{p;r,s}^{(2)} &= \frac{s_2}{\ell} \int_0^1 g_s^{(m_2)}(\eta) \sqrt{1-\eta} \, d\eta \int_0^1 h_r^{(n)}(\xi) \sqrt{\frac{1-\xi}{\xi}} f_p^{(2)}(x,u) \exp\left(-\frac{i\nu x}{\ell}\right) d\xi \\
& \quad r=1(1)n, \quad s=1(1)m_2, \quad (2-97)
\end{aligned}$$

$$\begin{aligned}
\psi_{i,j;r,s}^{(1,1)} &= \frac{s_1}{4\pi\ell} \int_0^1 g_j^{(m_1)}(\eta) \sqrt{1-\eta} \, d\eta \int_0^1 h_i^{(n)}(1-\xi) \sqrt{\frac{\xi}{1-\xi}} w_{r,s}^{(1,1)}(x,z;\nu,M) d\xi \\
& \quad \begin{cases} i=1(1)n, & j=1(1)m_1, \\ r=1(1)n, & s=1(1)m_1, \end{cases} \quad (2-98)
\end{aligned}$$

$$\begin{aligned}
\psi_{i,j;r,s}^{(1,2)} &= \frac{s_1}{4\pi\ell} \int_0^1 g_j^{(m_1)}(\eta) \sqrt{1-\eta} \, d\eta \int_0^1 h_i^{(n)}(1-\xi) \sqrt{\frac{\xi}{1-\xi}} w_{r,s}^{(1,2)}(x,z;\nu,M) d\xi \\
& \quad \begin{cases} i=1(1)n, & j=1(1)m_1, \\ r=1(1)n, & s=1(1)m_2, \end{cases} \quad (2-99)
\end{aligned}$$

$$\psi_{i,j;r,s}^{(2,1)} = \frac{s_2}{4\pi l} \int_0^1 g_j^{(m_2)}(\eta) \sqrt{1-\eta} \, d\eta \int_0^1 h_i^{(n)}(1-\xi) \sqrt{\frac{\xi}{1-\xi}} w_{r,s}^{(2,1)}(x,u;v,M) \, d\xi$$

$$\begin{cases} i = 1(1)n, & j = 1(1)m_2, \\ r = 1(1)n, & s = 1(1)m_1, \end{cases} \quad (2-100)$$

$$\psi_{i,j;r,s}^{(2,2)} = \frac{s_2}{4\pi l} \int_0^1 g_j^{(m_2)}(\eta) \sqrt{1-\eta} \, d\eta \int_0^1 h_i^{(n)}(1-\xi) \sqrt{\frac{\xi}{1-\xi}} w_{r,s}^{(2,2)}(x,u;v,M) \, d\xi$$

$$\begin{cases} i = 1(1)n, & j = 1(1)m_2, \\ r = 1(1)n, & s = 1(1)m_2, \end{cases} \quad (2-101)$$

$$\psi_{i,j;r,s}^{(2,3)} = \frac{s_2}{4\pi l} \int_0^1 g_j^{(m_2)}(\eta) \sqrt{1-\eta} \, d\eta \int_0^1 h_i^{(n)}(1-\xi) \sqrt{\frac{\xi}{1-\xi}} w_{r,s}^{(2,3)}(x,u;v,M) \, d\xi$$

$$\begin{cases} i = 1(1)n, & j = 1(1)m_2, \\ r = 1(1)n, & s = 1(1)m_2. \end{cases} \quad (2-102)$$

We eliminate $A_{q;r,l}^{(1)}$, $r = 1(1)n$, and $\bar{A}_{p;i,l}^{(1)}$, $i = 1(1)n$, from the expression (2-93) for \hat{Q}_{pq} by using relations (2-59) and (2-82). The result of doing this is that we get

$$\begin{aligned} \hat{Q}_{pq} = & \sum_{i=1}^n 2\bar{A}_{p;i,l}^{(2)} \left(-\theta_{q;i,l}^{(1)} + \theta_{q;i,l}^{(2)} \right) + \sum_{r=1}^n 2A_{q;r,l}^{(2)} \left(-\phi_{p;r,l}^{(1)} + \phi_{p;r,l}^{(2)} \right) \\ & + \sum_{i=1}^n \sum_{j=2}^{m_1} \bar{A}_{p;i,j}^{(1)} \theta_{q;i,j}^{(1)} + \sum_{i=1}^n \sum_{j=2}^{m_2} 2\bar{A}_{p;i,j}^{(2)} \theta_{q;i,j}^{(2)} \\ & + \sum_{r=1}^n \sum_{s=2}^{m_1} A_{q;r,s}^{(1)} \phi_{p;r,s}^{(1)} + \sum_{r=1}^n \sum_{s=2}^{m_2} 2A_{q;r,s}^{(2)} \phi_{p;r,s}^{(2)} \\ & + \sum_{i=1}^n \sum_{r=1}^n 2\bar{A}_{p;i,l}^{(2)} A_{q;r,l}^{(2)} \left(-2\psi_{i,l;r,l}^{(1,1)} + 2\psi_{i,l;r,l}^{(1,2)} + 2\psi_{i,l;r,l}^{(2,1)} \right. \\ & \quad \left. - \psi_{i,l;r,l}^{(2,2)} - \psi_{i,l;r,l}^{(2,3)} \right) \end{aligned}$$

$$\begin{aligned}
& + \sum_{i=1}^n \sum_{j=2}^{m_1} \sum_{r=1}^n 2\bar{A}_{p;i,j}^{(1)} A_{q;r,1}^{(2)} \left(\psi_{i,j;r,1}^{(1,1)} - \psi_{i,j;r,1}^{(1,2)} \right) \\
& + \sum_{i=1}^n \sum_{j=2}^{m_2} \sum_{r=1}^n 2\bar{A}_{p;i,j}^{(2)} A_{q;r,1}^{(2)} \left(2\psi_{i,j;r,1}^{(2,1)} - \psi_{i,j;r,1}^{(2,2)} - \psi_{i,j;r,1}^{(2,3)} \right) \\
& + \sum_{i=1}^n \sum_{r=1}^n \sum_{s=2}^{m_1} 2\bar{A}_{p;i,l}^{(2)} A_{q;r,s}^{(1)} \left(\psi_{i,l;r,s}^{(1,1)} - \psi_{i,l;r,s}^{(2,1)} \right) \\
& + \sum_{i=1}^n \sum_{r=1}^n \sum_{s=2}^{m_2} 2\bar{A}_{p;i,l}^{(2)} A_{q;r,s}^{(2)} \left(2\psi_{i,l;r,s}^{(1,2)} - \psi_{i,l;r,s}^{(2,2)} - \psi_{i,l;r,s}^{(2,3)} \right) \\
& - \sum_{i=1}^n \sum_{j=2}^{m_1} \sum_{r=1}^n \sum_{s=2}^{m_1} \bar{A}_{p;i,j}^{(1)} A_{q;r,s}^{(1)} \psi_{i,j;r,s}^{(1,1)} \\
& - \sum_{i=1}^n \sum_{j=2}^{m_1} \sum_{r=1}^n \sum_{s=2}^{m_2} 2\bar{A}_{p;i,j}^{(1)} A_{q;r,s}^{(2)} \psi_{i,j;r,s}^{(1,2)} \\
& - \sum_{i=1}^n \sum_{j=2}^{m_2} \sum_{r=1}^n \sum_{s=2}^{m_1} 2\bar{A}_{p;i,j}^{(2)} A_{q;r,s}^{(1)} \psi_{i,j;r,s}^{(2,1)} \\
& - \sum_{i=1}^n \sum_{j=2}^{m_2} \sum_{r=1}^n \sum_{s=2}^{m_2} 2\bar{A}_{p;i,j}^{(2)} A_{q;r,s}^{(2)} \left(\psi_{i,j;r,s}^{(2,2)} + \psi_{i,j;r,s}^{(2,3)} \right) . \tag{2-103}
\end{aligned}$$

We may write formula (2-103) for \hat{Q}_{pq} as the matrix formula

$$[\hat{Q}_{pq}] = [\bar{A}_p][\lambda_q] + [\mu_p][A_q] - [\bar{A}_p][\Lambda][A_q] , \tag{2-104}$$

where

$$[\bar{A}_p] = \begin{bmatrix} \bar{A}_p^{(0)} & \bar{A}_p^{(1)} & \bar{A}_p^{(2)} \end{bmatrix} \tag{2-105}$$

$$A_q = \begin{bmatrix} A_q^{(0)} \\ A_q^{(1)} \\ A_q^{(2)} \end{bmatrix} \quad (2-106)$$

$$\lambda_q = \begin{bmatrix} \lambda_q^{(0)} \\ \lambda_q^{(1)} \\ \lambda_q^{(2)} \end{bmatrix} \quad (2-107)$$

$$\mu_p = \begin{bmatrix} \mu_p^{(0)} & \mu_p^{(1)} & \mu_p^{(2)} \end{bmatrix} \quad (2-108)$$

$$\Lambda = \begin{bmatrix} \Lambda(0,0) & \Lambda(0,1) & \Lambda(0,2) \\ \Lambda(1,0) & \Lambda(1,1) & \Lambda(1,2) \\ \Lambda(2,0) & \Lambda(2,1) & \Lambda(2,2) \end{bmatrix} \quad (2-109)$$

and

$[\hat{Q}_{pq}]$ is the 1×1 matrix with element \hat{Q}_{pq} ,

$$\begin{bmatrix} \bar{A}_p^{(0)} \end{bmatrix} \text{ is the row matrix of } n \text{ elements with the element } \bar{A}_{p;i,1}^{(2)} \quad i = 1(1)n, \quad (2-110)$$

in the i th column;

$$\begin{bmatrix} \bar{A}_p^{(1)} \end{bmatrix} \text{ is the row matrix of } n(m_1 - 1) \text{ elements with the element } \bar{A}_{p;i,j}^{(1)} \quad i = 1(1)m, \quad j = 2(1)m_1, \quad (2-111)$$

in the $n(j-2) + i$ th column;

$$\begin{bmatrix} \bar{A}_p^{(2)} \end{bmatrix} \text{ is the row matrix of } n(m_2 - 1) \text{ elements with the element } \bar{A}_{p;i,j}^{(2)} \quad i = 1(1)n, \quad j = 2(1)m_2, \quad (2-112)$$

in the $n(j-2) + i$ th column;

$\left[A_q^{(0)} \right]$ is the column matrix of n elements with the element

$$A_{q;r,1}^{(2)} \quad r = 1(1)n, \quad (2-113)$$

in the r th row;

$\left[A_q^{(1)} \right]$ is the column matrix of $n(m_1 - 1)$ elements with the element

$$A_{q;r,s}^{(1)} \quad r = 1(1)n, \quad s = 2(1)m_1, \quad (2-114)$$

in the $n(s-2) + r$ th row;

$\left[A_q^{(2)} \right]$ is the column matrix of $n(m_2 - 1)$ elements with the element

$$A_{q;r,s}^{(2)} \quad r = 1(1)n, \quad s = 2(1)m_2, \quad (2-115)$$

in the $n(s-2) + r$ th row;

$\left[\lambda_q^{(0)} \right]$ is the column matrix of n elements with the element

$$2 \left(-\theta_{q;i,1}^{(1)} + \theta_{q;i,1}^{(2)} \right) \quad i = 1(1)n, \quad (2-116)$$

in the i th row;

$\left[\lambda_q^{(1)} \right]$ is the column matrix of $n(m_1 - 1)$ elements with the element

$$\theta_{q;i,j}^{(1)} \quad i = 1(1)n, \quad j = 2(1)m_1, \quad (2-117)$$

in the $n(j-2) + i$ th row;

$\left[\lambda_q^{(2)} \right]$ is the column matrix of $n(m_2 - 1)$ elements with the element

$$2\theta_{q;i,j}^{(2)} \quad i = 1(1)n, \quad j = 2(1)m_2, \quad (2-118)$$

in the $n(j-2) + i$ th row;

$\left[\mu_p^{(0)} \right]$ is the row matrix of n elements with the element

$$2 \left(-\phi_{p;r,1}^{(1)} + \phi_{p;r,1}^{(2)} \right) \quad r = 1(1)n, \quad (2-119)$$

in the r th column;

$[\mu_p^{(1)}]$ is the row matrix of $n(m_1 - 1)$ elements with the element

$$\phi_{p;r,s}^{(1)} \quad r = 1(1)n, \quad s = 2(1)m_1, \quad (2-120)$$

in the $n(s-2) + r$ th column;

$[\mu_p^{(2)}]$ is the row matrix of $n(m_2 - 1)$ elements with the element

$$2\phi_{p;r,s}^{(2)} \quad r = 1(1)n, \quad s = 2(1)m_2, \quad (2-121)$$

in the $n(s-2) + r$ th column;

$[\Lambda^{(0,0)}]$ is the square matrix of order $n \times n$ with the element

$$4\psi_{i,l;r,l}^{(1,1)} - 4\psi_{i,l;r,l}^{(1,2)} - 4\psi_{i,l;r,l}^{(2,1)} + 2\psi_{i,l;r,l}^{(2,2)} + 2\psi_{i,l;r,l}^{(2,3)} \quad (2-122)$$

$$i = 1(1)n, \quad r = 1(1)n,$$

in the i th row and r th column;

$[\Lambda^{(0,1)}]$ is the rectangular matrix of order $n \times n(m_1 - 1)$ with the element

$$- 2\psi_{i,l;r,s}^{(1,1)} + 2\psi_{i,l;r,s}^{(2,1)} \quad \begin{cases} i = 1(1)n, \\ r = 1(1)n, \quad s = 2(1)m_1, \end{cases} \quad (2-123)$$

in the i th row and $n(s-2) + r$ th column;

$[\Lambda^{(0,2)}]$ is the rectangular matrix of order $n \times n(m_2 - 1)$ with the element

$$- 4\psi_{i,l;r,s}^{(1,2)} + 2\psi_{i,l;r,s}^{(2,2)} + 2\psi_{i,l;r,s}^{(2,3)} \quad \begin{cases} i = 1(1)n, \\ r = 1(1)n, \quad s = 2(1)m_2, \end{cases} \quad (2-124)$$

in the i th row and $n(s-2) + r$ th column;

$[\Lambda^{(1,0)}]$ is the rectangular matrix of order $n(m_1 - 1) \times n$ with the element

$$- 2\psi_{i,j;r,l}^{(1,1)} + 2\psi_{i,j;r,l}^{(1,2)} \quad \begin{cases} i = 1(1)n, \\ j = 2(1)m_1, \quad r = 1(1)n, \end{cases} \quad (2-125)$$

in the $n(j-2) + i$ th row and r th column;

$[A^{(1,1)}]$ is the square matrix of order $n(m_1 - 1) \times n(m_2 - 1)$ with the element

$$\psi_{i,j;r,s}^{(1,1)} \quad \begin{cases} i = 1(1)n, & j = 2(1)m_1, \\ r = 1(1)n, & s = 2(1)m_1, \end{cases} \quad (2-126)$$

in the $n(j-2) + \text{ith}$ row and $n(s-2) + \text{rth}$ column;

$[A^{(1,2)}]$ is the rectangular matrix of order $n(m_1 - 1) \times n(m_2 - 1)$ with the

$$\text{element } 2\psi_{i,j;r,s}^{(1,2)} \quad \begin{cases} i = 1(1)n, & j = 2(1)m_1, \\ r = 1(1)n, & s = 2(1)m_2, \end{cases} \quad (2-127)$$

in the $n(j-2) + \text{ith}$ row and $n(s-2) + \text{rth}$ column;

$[A^{(2,0)}]$ is the rectangular matrix of order $n(m_2 - 1) \times n$ with the element

$$-4\psi_{i,j;r,1}^{(2,1)} + 2\psi_{i,j;r,1}^{(2,2)} + 2\psi_{i,j;r,1}^{(2,3)} \quad \begin{cases} i = 1(1)n, & j = 2(1)m_2, \\ r = 1(1)n, \end{cases} \quad (2-128)$$

in the $n(j-2) + \text{ith}$ row and rth column;

$[A^{(2,1)}]$ is the rectangular matrix of order $n(m_2 - 1) \times n(m_1 - 1)$ with the

$$\text{element } 2\psi_{i,j;r,s}^{(2,1)} \quad \begin{cases} i = 1(1)n, & j = 2(1)m_2, \\ r = 1(1)n, & s = 2(1)m_1, \end{cases} \quad (2-129)$$

in the $n(j-2) + \text{ith}$ row and $n(s-2) + \text{rth}$ column;

$[A^{(2,2)}]$ is the square matrix of order $n(m_2 - 1) \times n(m_2 - 1)$ with the element

$$2\psi_{i,j;r,s}^{(2,2)} + 2\psi_{i,j;r,s}^{(2,3)} \quad \begin{cases} i = 1(1)n, & j = 2(1)m_2, \\ r = 1(1)n, & s = 2(1)m_2, \end{cases} \quad (2-130)$$

in the $n(j-2) + \text{ith}$ row and $n(s-2) + \text{rth}$ column.

The quantity \hat{Q}_{pq} of formula (2-104) is stationary for variations of the coefficients $A_{q;r,s}^{(1)}$, $A_{q;r,s}^{(2)}$, $\bar{A}_{p;i,j}^{(1)}$ and $\bar{A}_{p;i,j}^{(2)}$ when these coefficients are given by the matrix equations

$$[A_q] = [\Lambda]^{-1}[\lambda_q] \quad (2-131)$$

and

$$[\bar{A}_p] = [\mu_p][\Lambda]^{-1} \quad (2-132)$$

and the stationary value is

$$[\hat{Q}_{pq}] = [\mu_p][\Lambda]^{-1}[\lambda_q] \quad (2-133)$$

The quantity \hat{Q}_{pq} of the formula (2-104), however, takes the stationary value (2-133) either if the coefficients $A_{q;r,s}^{(1)}$ and $A_{q;r,s}^{(2)}$ are obtained from the matrix formula (2-131) and the coefficients $\bar{A}_{p;i,j}^{(1)}$ and $\bar{A}_{p;i,j}^{(2)}$ are arbitrary, or if the coefficients $A_{q;r,s}^{(1)}$ and $A_{q;r,s}^{(2)}$ are arbitrary and the coefficients $\bar{A}_{p;i,j}^{(1)}$ and $\bar{A}_{p;i,j}^{(2)}$ are obtained from the matrix formula (2-132), as may be shown by substitution of either of these sets of coefficients into formula (2-104). The stationary value (2-133) may be written in the alternative form

$$[\hat{Q}_{pq}] = [\mu_p][A_q] \quad (2-134)$$

where the column matrix A_q is given by formula (2-131). The form (2-134) together with the formulae (2-56) and (2-57) for $\hat{\ell}_q^{(1)}(x_0, z_0)$ and $\hat{\ell}_q^{(2)}(x_0, u_0)$ then enable us to write the stationary value in the form

$$\hat{Q}_{pq} = \frac{1}{\ell^2} \iint_{S_1} f_p^{(1)}(x, z) \hat{\ell}_q^{(1)}(x, z) dx dz + \frac{2}{\ell^2} \iint_{S_2} f_p^{(2)}(x, u) \hat{\ell}_q^{(2)}(x, u) dx du \quad (2-135)$$

which would be the formula obtained by replacing $\ell_q^{(1)}(x, z; v, M_\omega)$ and $\ell_q^{(2)}(x, u; v, M_\omega)$ in formula (2-83) by the approximations $\hat{\ell}_q^{(1)}(x, z)$ and $\hat{\ell}_q^{(2)}(x, u)$ respectively. However, even though we have shown that the stationary value \hat{Q}_{pq} takes the expected form (2-135) we shall evaluate it from the formula (2-133).

Let us now write

$$f_{p;r,s}^{(1)} = \frac{\ell}{s_1 H_r^{(n)} G_s^{(m_1)}} \exp\left(\frac{iv}{\ell} x_{r,s}^{(1,n,m_1)}\right) \phi_{p;r,s}^{(1)} \quad \begin{cases} r = 1(1)n, \\ s = 1(1)m_1, \end{cases} \quad (2-136)$$

$$f_{p;r,s}^{(2)} = \frac{\ell}{s_2 H_r^{(n)} G_s^{(m_2)}} \exp\left(\frac{i\nu}{\ell} x_{r,s}^{(2,n,m_2)}\right) \phi_{p;r,s}^{(2)} \quad \begin{cases} r = 1(1)n, \\ s = 1(1)m_2 \end{cases} \quad (2-137)$$

$$w_{q;i,j}^{(1)} = \frac{\ell}{s_1 H_i^{(n)} G_j^{(m_1)}} \exp\left(-\frac{i\nu}{\ell} \bar{x}_{i,j}^{(1,n,m_1)}\right) \theta_{q;i,j}^{(1)} \quad \begin{cases} i = 1(1)n, \\ j = 1(1)m_1, \end{cases} \quad (2-138)$$

$$w_{q;i,j}^{(2)} = \frac{\ell}{s_2 H_i^{(n)} G_j^{(m_2)}} \exp\left(-\frac{i\nu}{\ell} \bar{x}_{i,j}^{(2,n,m_2)}\right) \theta_{q;i,j}^{(2)} \quad \begin{cases} i = 1(1)n, \\ j = 1(1)m_2, \end{cases} \quad (2-139)$$

where

$$z_s^{(m_1)} = s_1 \eta_s^{(m_1)} \quad s = 1(1)m_1, \quad (2-140)$$

$$x_{r,s}^{(1,n,m_1)} = c_1 \left(z_s^{(m_1)}\right) \xi_r^{(n)} + e_1 \left(z_s^{(m_1)}\right) \quad \begin{cases} r = 1(1)n, \\ s = 1(1)m_1, \end{cases} \quad (2-141)$$

$$\bar{x}_{i,j}^{(1,n,m_1)} = c_1 \left(z_j^{(m_1)}\right) \left(1 - \xi_i^{(n)}\right) + e_1 \left(z_j^{(m_1)}\right) \quad \begin{cases} i = 1(1)n, \\ j = 1(1)m_1, \end{cases} \quad (2-142)$$

$$u_s^{(m_2)} = s_2 \eta_s^{(m_2)} \quad s = 1(1)m_2, \quad (2-143)$$

$$x_{r,s}^{(2,n,m_2)} = c_2 \left(u_s^{(m_2)}\right) \xi_r^{(n)} + e_2 \left(u_s^{(m_2)}\right) \quad s = 1(1)m_2, \quad (2-144)$$

$$\bar{x}_{i,j}^{(2,n,m_2)} = c_2 \left(u_j^{(m_2)}\right) \left(1 - \xi_i^{(n)}\right) + e_2 \left(u_j^{(m_2)}\right) \quad \begin{cases} i = 1(1)n, \\ j = 1(1)m_2. \end{cases} \quad (2-145)$$

If we use the numerical integration formulae (2-62) and (2-64) to evaluate $\phi_{p;r,s}^{(1)}$, $\phi_{p;r,s}^{(2)}$, $\theta_{q;i,j}^{(1)}$, $\theta_{q;i,j}^{(2)}$ in formulae (2-136) to (2-139), respectively we get

$$f_{p;r,s}^{(1)} \simeq f_p^{(1)} \left(x_{r,s}^{(1,n,m_1)}, z_s^{(m_1)}\right) \quad \begin{cases} r = 1(1)n, \\ s = 1(1)m_1, \end{cases} \quad (2-146)$$

$$f_{p;r,s}^{(2)} \simeq f_p^{(2)} \left(x_{r,s}^{(2,n,m_2)}, u_s^{(m_2)}\right) \quad \begin{cases} r = 1(1)n, \\ s = 1(1)m_2, \end{cases} \quad (2-147)$$

$$w_{q;i,j}^{(1)} \simeq w_q^{(1)} \left(\bar{x}_{i,j}^{(1,n,m_1)}, z_j^{(m_1)}; \nu\right) \quad \begin{cases} i = 1(1)n, \\ j = 1(1)m_1, \end{cases} \quad (2-148)$$

$$w_{q;i,j}^{(2)} \simeq w_q^{(2)} \left(\bar{x}_{i,j}^{(2,n,m_2)}, z_j^{(m_2)}; \nu\right) \quad \begin{cases} i = 1(1)n, \\ j = 1(1)m_2. \end{cases} \quad (2-149)$$

The approximations (2-146) to (2-149) may be very good at high values of n , m_1 and m_2 if $c_1(z)$, $e_1(z)$, $f_p^{(1)}(x,z)$ and $w_q^{(1)}(x,z;v)$ over the planform S_1 , and likewise $c_2(u)$, $e_2(u)$, $f_p^{(2)}(x,u)$ and $w_q^{(2)}(x,u;v)$ over the planform S_2 are continuous functions with only a few undulations. There are instances, *eg* control-surface rotation in which their accuracy is not as good as we desire unless n , m_1 and m_2 are unpractically high. If it is considered that the approximations (2-146) to (2-149) are not sufficiently accurate then the full formulae (2-136) to (2-139) must be used with the quantities $\phi_{p;r,s}^{(1)}$, $\phi_{p;r,s}^{(2)}$, $\theta_{q;i,j}^{(1)}$ and $\theta_{q;i,j}^{(2)}$ obtained from (2-96), (2-97), (2-94) and (2-95) respectively using accurate numerical integration schemes.

Let

$$\left[f_p^{(1)} \right] \text{ be the row matrix of } m_1 n \text{ elements with the element}$$

$$f_{p;r,s}^{(1)} \quad r = 1(1)n, s = 1(1)m_1, \quad (2-150)$$

in the $n(s-1) + r$ th column;

$$\left[f_p^{(2)} \right] \text{ be the row matrix of } m_2 n \text{ elements with the element}$$

$$f_{p;r,s}^{(2)} \quad r = 1(1)n, s = 1(1)m_2, \quad (2-151)$$

in the $n(s-1) + r$ th column;

$$\left[w_q^{(1)} \right] \text{ be the column matrix of } m_1 n \text{ elements with the element}$$

$$w_{q;i,j}^{(1)} \quad i = 1(1)n, j = 1(1)m_1, \quad (2-152)$$

in the $n(j-1) + i$ th row and

$$\left[w_q^{(2)} \right] \text{ be the column matrix of } m_2 n \text{ elements with the element}$$

$$w_{q;i,j}^{(2)} \quad i = 1(1)n, j = 1(1)m_2, \quad (2-153)$$

in the $n(j-1) + i$ th row.

Let

$[E_{10}]$ be the diagonal matrix of order $n \times n$ with the element

$$-\frac{2s_1}{\ell} H_r^{(n)} G_1^{(m_1)} \exp\left(-\frac{iv}{\ell} x_{r,l}^{(1,n,m_1)}\right) \quad r = 1(1)n, \quad (2-154)$$

in the r th row and column;

$[E_1]$ be the diagonal matrix of order $n(m_1 - 1) \times n(m_1 - 1)$ with the element

$$\frac{s_1}{\ell} H_r^{(n)} G_s^{(m_1)} \exp\left(-\frac{iv}{\ell} x_{r,s}^{(1,n,m_1)}\right) \quad r = 1(1)n, \quad s = 2(1)m_1, \quad (2-155)$$

in the $n(s-2) + r$ th row and column;

$[E_{20}]$ be the diagonal matrix of order $n \times n$ with the element

$$\frac{2s_2}{\ell} H_r^{(n)} G_l^{(m_2)} \exp\left(-\frac{iv}{\ell} x_{r,l}^{(2,n,m_2)}\right) \quad r = 1(1)n, \quad (2-156)$$

in the r th row and column; and

$[E_2]$ be the diagonal matrix of order $n(m_2 - 1) \times n(m_2 - 1)$ with the element

$$\frac{2s_2}{\ell} H_r^{(n)} G_s^{(m_2)} \exp\left(-\frac{iv}{\ell} x_{r,s}^{(2,n,m_2)}\right) \quad r = 1(1)n, \quad s = 2(1)m_2, \quad (2-157)$$

in the $n(s-2) + r$ th row and column.

Let

$[D_{10}]$ be the diagonal matrix of order $n \times n$ with the element

$$-\frac{2s_1}{\ell} H_i^{(n)} G_l^{(m_1)} \exp\left(\frac{iv}{\ell} x_{i,l}^{-(1,n,m_1)}\right) \quad i = 1(1)n, \quad (2-158)$$

in the i th row and column;

$[D_1]$ be the diagonal matrix of order $n(m_1 - 1) \times n(m_1 - 1)$ with the element

$$\frac{s_1}{\ell} H_i^{(n)} G_j^{(m_1)} \exp\left(\frac{iv}{\ell} \bar{x}_{i,j}^{(1,n,m_1)}\right) \quad i = 1(1)n, j = 2(1)m_1, \quad (2-159)$$

in the $n(j-2) + i$ th row and column;

$[D_{20}]$ be the diagonal matrix of order $n \times n$ with the element

$$\frac{2s_2}{\ell} H_i^{(n)} G_1^{(m_2)} \exp\left(\frac{iv}{\ell} \bar{x}_{i,1}^{(2,n,m_2)}\right) \quad i = 1(1)n, \quad (2-160)$$

in the i th row and column and

$[D_2]$ be the diagonal matrix of order $n(m_2 - 1) \times n(m_2 - 1)$ with the element

$$\frac{2s_2}{\ell} H_i^{(n)} G_j^{(m_2)} \exp\left(\frac{iv}{\ell} \bar{x}_{i,j}^{(2,n,m_2)}\right) \quad i = 1(1)n, j = 2(1)m_2, \quad (2-161)$$

in the $n(j-2) + i$ th row and column.

The matrix $[f_p]$ is defined to be the row matrix

$$[f_p] = \begin{bmatrix} f_p^{(1)} & f_p^{(2)} \end{bmatrix} \quad (2-162)$$

and the matrix $[w_q]$ is defined to be the column matrix

$$[w_q] = \begin{bmatrix} w_q^{(1)} \\ w_q^{(2)} \end{bmatrix} \quad (2-163)$$

The matrix $[E]$ is defined to be the matrix

$$[E] = \begin{bmatrix} E_{10} & 0 & 0 \\ 0 & E_1 & 0 \\ E_{20} & 0 & 0 \\ 0 & 0 & E_2 \end{bmatrix} \quad (2-164)$$

where the orders of the null matrices, represented by zeros, are taken to conform with the orders of the matrices $[E_{10}]$, $[E_1]$, $[E_{20}]$ and $[E_2]$.

The matrix $[D]$ is defined to be the matrix

$$[D] = \begin{bmatrix} D_{10} & 0 & D_{20} & 0 \\ 0 & D_1 & 0 & 0 \\ 0 & 0 & 0 & D_2 \end{bmatrix} \quad (2-165)$$

where the orders of the null matrices, represented by zeros, are taken to conform with the orders of the matrices $[D_{10}]$, $[D_1]$, $[D_{20}]$ and $[D_2]$.

The above matrix definitions enable us to write down the formulae

$$[\mu_p] = [f_p][E] \quad (2-166)$$

and

$$[\lambda_q] = [D][w_q] \quad (2-167)$$

Then, by substituting for $[\mu_p]$ and $[\lambda_q]$ from (2-166) and (2-167) into (2-133) we get

$$[\hat{Q}_{pq}] = [f_p][E][\Lambda]^{-1}[D][w_q] \quad (2-168)$$

which is the final formulation for the approximation $\hat{Q}_{p,q}$ to the generalised airforce coefficient $Q_{p,q}$.

Suppose that there are P modes of oscillation so that p and q take values $1(1)P$. Let $[f]$ be the matrix of order $P \times n(m_1 + m_2)$ obtained by arranging the row matrices $[f_p]$, $p = 1(1)P$, sequentially one below another. Let $[w]$ be the matrix of order $n(m_1 + m_2) \times P$ obtained by arranging the column matrices $[w_q]$, $q = 1(1)P$, sequentially one alongside another. Let \hat{Q}_{pq} be the square matrix of order $P \times P$ which has the element \hat{Q}_{pq} in the p th row and q th column, $p = 1(1)P$, $q = 1(1)P$. Then we get immediately from formula (2-168)

$$[\hat{Q}] = [f][E][\Lambda]^{-1}[D][w] \quad (2-169)$$

2.3 Evaluation of the loading on the surfaces S_1 and S_2

We can obtain the approximations $\hat{\lambda}_q^{(1)}(x_0, z_0)$ and $\hat{\lambda}_q^{(2)}(x_0, u_0)$ to the loading function $\lambda_q^{(1)}(x_0, z_0; v, M)$ on the fin S_1 and to the loading function

$\hat{\lambda}_q^{(2)}(x_0, u_0; \nu, M)$ on the half tailplane S_2 respectively, in the mode q of oscillation, directly from formulae (2-56) and (2-57). However, we prefer to proceed indirectly and obtain first the values of $\hat{\lambda}_q^{(1)}(x_0, z_0)$ at the loading points on the fin S_1 , $(x_{r,s}^{(1,n,m_1)}, z_s^{(m_1)})$ given by formulae (2-140) and (2-141) and the values of $\hat{\lambda}_q^{(2)}(x_0, u_0)$ at the loading points on the tailplane S_2 , $(x_{r,s}^{(2,n,m_2)}, u_s^{(m_2)})$ given by formulae (2-143) and (2-144). These are obtained immediately from formulae (2-56) and (2-57) by making use of the properties (2-53) and (2-54) of $h_r^{(n)}(\xi_0)$ and $g_s^{(m)}(\eta_0)$ and are

$$\hat{\lambda}_q^{(1)}(x_{r,s}^{(1,n,m_1)}, z_s^{(m_1)}) = \frac{\ell}{c_1(z_s^{(m_1)})} \exp\left(-\frac{i\nu}{\ell} x_{r,s}^{(1,n,m_1)}\right) \sqrt{\frac{1-\xi_r^{(n)}}{\xi_r^{(n)}}} \sqrt{1-\eta_s^{(m_1)}} A_{q;r,s}^{(1)}$$

$r = 1(1)n, s = 1(1)m_1, \quad (2-170)$

and

$$\hat{\lambda}_q^{(2)}(x_{r,s}^{(2,n,m_2)}, u_s^{(m_2)}) = \frac{\ell}{c_2(u_s^{(m_2)})} \exp\left(-\frac{i\nu}{\ell} x_{r,s}^{(2,n,m_2)}\right) \sqrt{\frac{1-\xi_r^{(n)}}{\xi_r^{(n)}}} \sqrt{1-\eta_s^{(m_2)}} A_{q;r,s}^{(2)}$$

$r = 1(1)n, s = 1(1)m_2. \quad (2-171)$

With the use of the relations (2-58) and (2-59) we may write the two formulae (2-170) and (2-171) as the single matrix formula

$$[\hat{\lambda}_q] = [F][A_q] \quad (2-172)$$

where

$$[\hat{\lambda}_q] = \begin{bmatrix} \hat{\lambda}_q^{(0)} \\ \hat{\lambda}_q^{(1)} \\ \hat{\lambda}_q^{(2)} \end{bmatrix} \quad (2-173)$$

$$[F] = \begin{bmatrix} F_0 & 0 & 0 \\ 0 & F_1 & 0 \\ 0 & 0 & F_2 \end{bmatrix} \quad (2-174)$$

and

$\left[\hat{\ell}_q^{(0)} \right]$ is the column matrix of n elements with the element

$$\hat{\ell}_q^{(2)} \left(x_{r,l}^{(2,n,m_2)}, u_1^{(m_2)} \right) = - \frac{1}{2} \hat{\ell}_q^{(1)} \left(x_{r,l}^{(1,n,m_1)}, z_1^{(m_1)} \right) \quad (2-175)$$

$r = 1(1)n,$

in the r th row;

$\left[\hat{\ell}_q^{(1)} \right]$ is the column matrix of n elements with the element

$$\hat{\ell}_q^{(1)} \left(x_{r,s}^{(1,n,m_1)}, z_s^{(m_1)} \right) \quad r = 1(1)n, s = 2(1)m_1, \quad (2-176)$$

in the $n(s-2) + r$ th row;

$\left[\hat{\ell}_q^{(2)} \right]$ is the column matrix of $n(m_2 - 1)$ elements with the element

$$\hat{\ell}_q^{(2)} \left(x_{r,s}^{(2,n,m_2)}, u_s^{(m_2)} \right) \quad r = 1(1)n, s = 2(1)m_2, \quad (2-177)$$

in the $n(s-2) + r$ th row;

$[F_0]$ is the diagonal matrix of order $n \times n$ with the element

$$\frac{\ell}{c_1 \left(z_1^{(m_1)} \right)} \exp \left(- \frac{i\nu}{\ell} x_{r,l}^{(1,n,m_1)} \right) \sqrt{\frac{1 - \xi_r^{(n)}}{\xi_r^{(n)}}} \sqrt{1 - \eta_1^{(m_1)}} \\ = \frac{\ell}{c_2 \left(u_1^{(m_2)} \right)} \exp \left(- \frac{i\nu}{\ell} x_{r,l}^{(2,n,m_2)} \right) \sqrt{\frac{1 - \xi_r^{(n)}}{\xi_r^{(n)}}} \sqrt{1 - \eta_1^{(m_2)}} \quad (2-178)$$

$r = 1(1)n,$

in the r th row and column;

$[F_1]$ is the diagonal matrix of order $n(m_1 - 1) \times n(m_1 - 1)$ with the element

$$\frac{\ell}{c_1 \left(z_s^{(m_1)} \right)} \exp \left(- \frac{i\nu}{\ell} x_{r,s}^{(1,n,m_1)} \right) \sqrt{\frac{1 - \xi_r^{(n)}}{\xi_r^{(n)}}} \sqrt{1 - \eta_s^{(m_1)}} \quad \begin{cases} r = 1(1)n, \\ s = 2(1)m_1, \end{cases} \quad (2-179)$$

is the $n(s-2) + r$ th row and column; and

$[F_2]$ is the diagonal matrix of order $n(m_2 - 1) \times n(m_2 - 1)$ with the element

$$\frac{\ell}{c_2(u_s^{(m_2)})} \exp\left(-\frac{i\nu}{\ell} x_{r,s}^{(2,n,m_2)}\right) \sqrt{\frac{1 - \xi_r^{(n)}}{\xi_r^{(n)}}} \sqrt{1 - \eta_s^{(m_2)}} \quad \begin{cases} r = 1(1)n, \\ s = 2(1)m_2, \end{cases} \quad (2-180)$$

in the $n(s-2) + r$ th row and column.

The zeros in (2-174) represent null matrices the orders of which are taken to conform with the orders of the matrices $[F_0]$, $[F_1]$ and $[F_2]$. The column matrix $[A_q]$ has already been defined in formula (2-106).

If we use the relationships (2-131) and (2-167) we may write instead of formula (2-172) the equivalent formula

$$[\hat{\ell}_q] = [F][A]^{-1}[D][w_q] \quad (2-181)$$

which, with (2-175), enables us to obtain $\hat{\ell}_q^{(1)}(x_{r,s}^{(1,n,m_1)}, z_s^{(m_1)})$, $r = 1(1)n$, $s = 1(1)m_1$, and $\hat{\ell}_q^{(2)}(x_{r,s}^{(2,n,m_2)}, z_s^{(m_2)})$, $r = 1(1)n$, $s = 1(1)m_2$, in terms of known quantities.

If now we express $A_{q;r,s}^{(1)}$ in terms of $\hat{\ell}_q^{(1)}(x_{r,s}^{(1,n,m_1)}, z_s^{(m_1)})$ from formulae (2-170) and $A_{q;r,s}^{(2)}$ in terms of $\hat{\ell}_q^{(2)}(x_{r,s}^{(2,n,m_2)}, u_s^{(m_2)})$ from formulae (2-171), we may use formulae (2-56), (2-57) and (2-175) to express $\hat{\ell}_q^{(1)}(x_0, z_0)$ at any point (x_0, z_0) on the fin S_1 and $\hat{\ell}_q^{(2)}(x, u)$ at any point (x, u) on the tailplane S_2 in terms of $\hat{\ell}_q^{(1)}(x_{r,s}^{(1,n,m_1)}, z_s^{(m_1)})$, $r = 1(1)n$, $s = 1(1)m_1$, and $\hat{\ell}_q^{(2)}(x_{r,s}^{(2,n,m_2)}, u_s^{(m_2)})$, $r = 1(1)n$, $s = 1(1)m_2$, by means of the formula

$$\begin{bmatrix} \hat{\ell}_q^{(1)}(x_0, z_0) \\ \hat{\ell}_q^{(2)}(x, u) \end{bmatrix} = \begin{bmatrix} H_1(x_0, z_0) & 0 \\ 0 & H_2(x, u) \end{bmatrix} [G][\hat{\ell}_q] \quad (2-182)$$

where $\begin{bmatrix} \hat{\ell}_q^{(1)}(x_0, z_0) \end{bmatrix}$ is the 1×1 matrix with element $\hat{\ell}_q^{(1)}(x_0, z_0)$,
 $\begin{bmatrix} \hat{\ell}_q^{(2)}(x, u) \end{bmatrix}$ is the 1×1 matrix with element $\hat{\ell}_q^{(2)}(x, u)$,

$[H_1(x_0, z_0)]$ is the row matrix of nm_1 elements with the element

$$\frac{\ell}{c_1(z_0)} \exp\left(-\frac{ivx_0}{\ell}\right) h_r^{(n)}(\xi_0) g_s^{(m_1)}(\eta_0) \sqrt{\frac{1-\xi_0}{\xi_0}} \sqrt{1-\eta_0} \quad (2-183)$$

$$r = 1(1)n, \quad s = 1(1)m_1,$$

in the $n(s-1) + r$ th column; and

$[H_2(x, u)]$ is the row matrix of nm_2 elements with the element

$$\frac{\ell}{c_2^{(n)}} \exp\left(-\frac{ivx}{\ell}\right) h_r^{(n)}(\xi) g_s^{(m_2)}(\eta) \sqrt{\frac{1-\xi}{\xi}} \sqrt{1-\eta} \quad (2-184)$$

$$r = 1(1)n, \quad s = 1(1)m_2,$$

in the $n(s-1) + r$ th column; and $[G]$ is the matrix

$$[G] = \begin{bmatrix} -2F_0^{-1} & 0 & 0 \\ 0 & F_1^{-1} & 0 \\ F_0^{-1} & 0 & 0 \\ 0 & 0 & F_2^{-1} \end{bmatrix}. \quad (2-185)$$

The matrices $[F_0]$, $[F_1]$, $[F_2]$ have already been defined in (2-178) to (2-180) and the column matrix $[\hat{\ell}_q]$ has been defined in (2-173). The zeros in (2-185) represent null matrices the orders of which are taken to conform with the orders of the other matrices in the formula.

If $[\hat{\ell}]$ is the matrix of order $n(m_1 + m_2 - 1) \times P$ obtained by arranging the column matrices

$$\begin{bmatrix} \hat{\ell}_q^{(0)} \\ \hat{\ell}_q^{(1)} \\ \hat{\ell}_q^{(2)} \end{bmatrix} \quad q = 1(1)P, \quad (2-186)$$

sequentially one alongside another, and if $[\hat{\ell}^{(1)}(x_0, z_0)]$ and $[\hat{\ell}^{(2)}(x, u)]$ are the matrices of order $1 \times P$ obtained by similarly arranging respectively the matrices $[\hat{\ell}_q^{(1)}(x_0, z_0)]$ and $[\hat{\ell}_q^{(2)}(x, u)]$, $q = 1(1)P$, then we get immediately from formulae (2-181) and (2-182) respectively the formulae

$$[\hat{\lambda}] = [F][\Lambda]^{-1}[D][w] \quad (2-187)$$

and

$$\begin{bmatrix} \hat{\lambda}^{(1)}(x_0, z_0) \\ \hat{\lambda}^{(2)}(x, u) \end{bmatrix} = \begin{bmatrix} H_1(x_0, z_0) & 0 \\ 0 & H_2(x, u) \end{bmatrix} [G][\hat{\lambda}] \quad (2-188)$$

where the matrix $[w]$ has been defined just before formula (2-169).

The formulae (2-187) and (2-188) may, of course, be combined to give $[\hat{\lambda}^{(1)}(x_0, z_0)]$ and $[\hat{\lambda}^{(2)}(x, u)]$ in terms of $[w]$ directly in one formula. However, it is convenient to have the formula (2-187) so as to be able to obtain values of the loadings at the loading points $(x_{r,s}^{(1,n,m_1)}, z_s^{(m_1)})$ on the fin S_1 and the loading points $(x_{r,s}^{(2,n,m_2)}, u_s^{(m_2)})$ on the half-tailplane S_2 (see (2-140), (2-141), (2-143) and (2-144)).

3 NUMERICAL INTEGRATION

The quantities $\theta_{q;i,j}^{(1)}$, $\theta_{q;i,j}^{(2)}$, $\phi_{p;r,s}^{(1)}$, $\phi_{p;r,s}^{(2)}$, $\psi_{i,j;r,s}^{(1,1)}$, $\psi_{i,j;r,s}^{(1,2)}$, $\psi_{i,j;r,s}^{(2,1)}$, $\psi_{i,j;r,s}^{(2,2)}$ and $\psi_{i,j;r,s}^{(2,3)}$ are to be evaluated numerically from formulae (2-94) to (2-102) so that the numerical values of the elements of the matrices $[\lambda_q]$, $[\mu_p]$ and $[\Lambda]$ may be determined. As we mentioned immediately prior to formula (2-146), we may use the numerical integration formulae (2-62) and (2-64) for the evaluation of the quantities $\theta_{q;i,j}^{(1)}$, $\theta_{q;i,j}^{(2)}$, $\phi_{p;r,s}^{(1)}$ and $\phi_{p;r,s}^{(2)}$.

It would be a simple matter, however, to use more accurate formulae than (2-62) and (2-64), involving more integration points, to get these values to higher accuracy. The procedure is straightforward and need not be discussed here. In this section we shall discuss procedures for carrying out the numerical evaluations of $\psi_{i,j;r,s}^{(1,1)}$, $\psi_{i,j;r,s}^{(1,2)}$, $\psi_{i,j;r,s}^{(2,1)}$, $\psi_{i,j;r,s}^{(2,2)}$ and $\psi_{i,j;r,s}^{(2,3)}$ for these are rather more involved than is the aforementioned one.

We shall need certain formulae for numerical integration. Some of these are derived in Appendix A and the others are assumed to be well known to the reader.

3.1 Evaluation of $\psi_{i,j;r,s}^{(1,1)}$

The numerical integration over η will be carried out over m_1' integration points and the numerical integration over ξ will be carried out over n_1'

integration points in the numerical evaluation of the repeated integral on the right hand side of the formula (2-98) that defines $\psi_{i,j;r,s}^{(1,1)}$. This integration will require the values of $w_{r,s}^{(1,1)}(x,z;v,M)$ at the integration points and these values are obtained from formula (2-70). In the numerical evaluation of the repeated integral on the right-hand side of the formula (2-70) for $w_{r,s}^{(1,1)}(x,z;v,M)$ the numerical integration over η_0 will be carried out over \bar{m}_1 integration points and, for each of these, the numerical integration over ξ_0 will be carried out over a large number of integration points, the number not being prespecified but rather determined during the course of the calculation.

The integrand of the η_0 integral in the repeated integral of formula (2-70) has a severe singularity at $\eta_0 = \eta$. We may avoid certain numerical accuracy difficulties by taking the integration points for the η integration in the repeated integral of formula (2-98) to be a selection of the integration points for the η_0 integration in the repeated integral of formula (2-70) for then an integration point of one of the integrals is never slightly different from an integration point of the other integral. Coincident integration points do not cause numerical accuracy difficulties for analytical techniques are used in parts of the process. If we do use such a selection for the η integration in the repeated integral of formula (2-98) then it is not possible to use Gaussian numerical integration for both the η integration in formula (2-98) and the η_0 integration in formula (2-70) unless the number of points in both sets are the same. We choose to use Gaussian numerical integration for the η_0 integration of formula (2-70).

Let the Gaussian formula of numerical integration for the weight function $\sqrt{1-\eta}$ and for \bar{m} integration points be

$$\int_0^1 F(\eta) \sqrt{1-\eta} \, d\eta = \sum_{k=1}^{\bar{m}} F(\zeta_k^{(\bar{m})}) \bar{G}_k^{(\bar{m})} \quad (3-1)$$

where $F(\eta)$ is an arbitrary function.

The points

$$\zeta_k^{(\bar{m})} \quad k = 1(1)\bar{m}, \quad (3-2)$$

satisfy

$$\frac{P_{2\bar{m}+1}(\sqrt{1-\zeta_k^{(\bar{m})}})}{\sqrt{1-\zeta_k^{(\bar{m})}}} = 0 \quad k = 1(1)\bar{m}, \quad (3-3)$$

as is shown in Appendix A, $P_r(u)$ being the Legendre polynomial of degree r in u . The integration multipliers

$$\bar{G}_k^{(\bar{m})} \quad k = 1(1)\bar{m}, \quad (3-4)$$

correspond to the integration points (3-2) and their numerical evaluation is discussed in Appendix A.

We now need to supply an integration formula for the weight function $\sqrt{1-\eta}$ and for m' integration points which are a selection of the integration points (3-2). We can choose the numbers m' and \bar{m} of integration points quite independently of each other provided that $m' < \bar{m}$ and then select the m' integration points in any manner that we like from the \bar{m} integration points $\zeta_k^{(\bar{m})}$. However, if we take m' and \bar{m} to be related by means of the formula

$$\bar{m} = a(m' + 1) - 1 \quad (3-5)$$

where a is some positive integer, then the $\zeta_k^{(\bar{m})}$, $k = 1(1)\bar{m}$, may be arranged into $(m' + 1)$ groups of $(a - 1)$ consecutive values of $\zeta_k^{(\bar{m})}$ separated by the m' values

$$\chi_j^{(m', \bar{m})} = \zeta_{aj}^{(\bar{m})} \quad j = 1(1)m', \quad (3-6)$$

which we take to be the m' integration points. The formula of numerical integration for the weight function $\sqrt{1-\eta}$ and for the m' integration points (3-6) then takes the form

$$\int_0^1 F(\eta) \sqrt{1-\eta} \, d\eta = \sum_{j=1}^{m'} F(\chi_j^{(m', \bar{m})}) G_j^{(m', \bar{m})} \quad (3-7)$$

where the integration multipliers

$$G_j^{(m', \bar{m})} \quad j = 1(1)m', \quad (3-8)$$

correspond to the integration points (3-6). The details of the numerical procedure for evaluating the $G_j^{(m', \bar{m})}$ are given in Appendix A.

If

$$a = 1 \quad (3-9)$$

then

$$m' = \bar{m} \quad (3-10)$$

and the numerical integration formula (3-7) becomes identical with the Gaussian numerical integration formula (3-1).

If

$$a > 1 \quad (3-11)$$

then the numerical integration formula (3-7) is not as accurate as the Gaussian numerical integration formula for m' points but for low values of a accuracy should be good.

We shall also need the integration formula for the ξ integration (see, eg Ref 11)

$$\int_0^1 f(\xi) \sqrt{\frac{1-\xi}{\xi}} d\xi = \sum_{p=1}^{n'} f(\xi_p^{(n')}) H_p^{(n')} \quad (3-12)$$

where

$$\xi_p^{(n')} = \frac{1}{2} - \frac{1}{2} \cos\left(\frac{2p-1}{2n'+1} \pi\right) \quad p=1(1)n', \quad (3-13)$$

and

$$H_p^{(n')} = \frac{2\pi}{(2n'+1)} \left(1 - \xi_p^{(n')}\right) \quad p=1(1)n'. \quad (3-14)$$

Let us apply the numerical formulae of integration (3-7) and (3-12) to the evaluation of $\psi_{i,j;r,s}^{(1,1)}$ from formula (2-98). On taking $m' = m'_1$, $n' = n'_1$ and

$$\bar{m} = \bar{m}_1 = a_1(m'_1 + 1) - 1, \quad (3-15)$$

where a_1 is some positive integer, we get the result

$$\begin{aligned} \psi_{i,j;r,s}^{(1,1)} &= \frac{s_1}{4\pi l} \sum_{p=1}^{n'_1} \sum_{q=1}^{m'_1} H_p^{(n'_1)} G_q^{(m'_1, \bar{m}_1)} h_i^{(n)} \left(\xi_p^{(n'_1)}\right) g_j^{(m_1)} \left(\chi_q^{(m'_1, \bar{m}_1)}\right) \\ &\quad \times w_{r,s}^{(1,1)} \left(\bar{x}_{p,q}^{(n'_1, m'_1, \bar{m}_1)}, z_q^{(m'_1, \bar{m}_1)}; v, M\right) \end{aligned} \quad (3-16)$$

where
$$\bar{x}_{p,q}^{(n_1', m_1', \bar{m}_1)} = c_1 \left(z_q^{(m_1', \bar{m}_1)} \right) \bar{\xi}_p^{(n_1')} + e_1 \left(z_q^{(m_1', \bar{m}_1)} \right), \quad (3-17)$$

$$z_q^{(m_1', \bar{m}_1)} = s_1 \chi_q^{(m_1', \bar{m}_1)}, \quad (3-18)$$

$$\bar{\xi}_p^{(n_1')} = 1 - \xi_p^{(n_1')}. \quad (3-19)$$

We now evaluate $w_{r,s}^{(1,1)} \left(\bar{x}_{p,q}^{(n_1', m_1', \bar{m}_1)}, z_q^{(m_1', \bar{m}_1)}; \nu, M \right)$ from formula (2-70), which we take in the form

$$\begin{aligned} & w_{r,s}^{(1,1)} \left(\bar{x}_{p,q}^{(n_1', m_1', \bar{m}_1)}, z_q^{(m_1', \bar{m}_1)}; \nu, M \right) \\ &= \frac{s_1}{l} \int_0^1 g_s^{(m_1)}(\eta_0) I_r^{(n)} \left(\bar{\xi}_p^{(n_1')}, \chi_q^{(m_1', \bar{m}_1)}, \eta_0; \nu, M \right) \frac{\sqrt{1-\eta_0} d\eta_0}{\left(\chi_q^{(m_1', \bar{m}_1)} - \eta_0 \right)^2}, \quad (3-20) \end{aligned}$$

where

$$\begin{aligned} & I_r^{(n)} \left(\bar{\xi}_p^{(n_1')}, \chi_q^{(m_1', \bar{m}_1)}, \eta_0; \nu, M \right) \\ &= \left(\chi_q^{(m_1', \bar{m}_1)} - \eta_0 \right)^2 \int_0^1 h_r^{(n)}(\xi_0) K_1 \left(\frac{\bar{x}_{p,q}^{(n_1', m_1', \bar{m}_1)} - x_0}{l}, \frac{z_q^{(m_1', \bar{m}_1)} - z_0}{l}; \nu, M \right) \sqrt{\frac{1-\xi_0}{\xi_0}} d\xi_0. \end{aligned}$$

..... (3-21)

The integral on the right-hand side of formula (3-20) is an improper integral and to evaluate it we separate from the integrand a part that we can deal with analytically and use a numerical integration formula for the remainder.

Let us define the function $I_r^{(n)*} \left(\bar{\xi}_p^{(n_1')}, \chi_q^{(m_1', \bar{m}_1)}, \eta_0; \nu, M \right)$ by means of the formula

$$\begin{aligned}
& I_r^{(n)*} \left(\bar{\xi}_p^{(n_1')}, \chi_q^{(m_1', \bar{m}_1)}, \eta_0; \nu, M \right) \\
&= I_r^{(n)} \left(\bar{\xi}_p^{(n_1')}, \chi_q^{(m_1', \bar{m}_1)}, \eta_0; \nu, M \right) \\
&\quad - \left(\frac{\ell}{c_1(z_q^{(m_1', \bar{m}_1)})} \right)^2 \left(\chi_q^{(m_1', \bar{m}_1)} - \eta_0 \right)^2 \log \left| \chi_q^{(m_1', \bar{m}_1)} - \eta_0 \right| \\
&\quad \times F_r^{(n)} \left(\bar{\xi}_p^{(n_1')}, 0; \frac{\nu c_1(z_q^{(m_1', \bar{m}_1)})}{\ell}, M \right) \tag{3-22}
\end{aligned}$$

where $F_r^{(n)}(\xi, \sigma, \mu, M)$ is defined in formula (B-19) of Appendix B, and the particular form

$$\begin{aligned}
F_r^{(n)}(\xi, 0; \mu, M) = & \left[-\beta^2 \frac{d}{d\xi} \left(h_r^{(n)}(\xi) \sqrt{\frac{1-\xi}{\xi}} \right) + 2i\mu h_r^{(n)}(\xi) \sqrt{\frac{1-\xi}{\xi}} \right. \\
& \left. - (i\mu)^2 \int_0^\xi h_r^{(n)}(\xi_0) \sqrt{\frac{1-\xi_0}{\xi_0}} d\xi_0 \right], \tag{3-23}
\end{aligned}$$

is obtained from formula (B-53). Then we write formula (3-20) in the form

$$\begin{aligned}
 & w_{r,s}^{(l,1)} \left(\bar{x}_{p,q}^{(n_1, \bar{m}_1)}, z_{p,q}^{(n_1, \bar{m}_1)}; \nu, M \right) \\
 &= \frac{s_1}{\ell} \int_0^1 \int_0^1 \left\{ g_s^{(m_1)} (\eta_0) I_r^{(n)} \left(\xi_p^{(n_1)}, x_q^{(m_1, \bar{m}_1)}, \eta_0; \nu, M \right) - g_s^{(m_1)} \left(x_q^{(m_1, \bar{m}_1)} \right) I_r^{(n)} \left(\bar{\xi}_p^{(n_1)}, x_q^{(m_1, \bar{m}_1)}, x_q^{(m_1, \bar{m}_1)}; \nu, M \right) \right. \\
 &\quad \left. - \left(\eta_0 - x_q^{(m_1, \bar{m}_1)} \right) \left[\frac{\partial}{\partial \eta_0} g_s^{(m_1)} (\eta_0) I_r^{(n)} \left(\bar{\xi}_p^{(n_1)}, x_q^{(m_1, \bar{m}_1)}, \eta_0; \nu, M \right) \right] \right\} \frac{\sqrt{1 - \eta_0} d\eta_0}{\left(x_q^{(m_1, \bar{m}_1)} - \eta_0 \right)^2} \\
 &+ \frac{s_1}{\ell} g_s^{(m_1)} \left(x_q^{(m_1, \bar{m}_1)} \right) I_r^{(n)} \left(\bar{\xi}_p^{(n_1)}, x_q^{(m_1, \bar{m}_1)}, x_q^{(m_1, \bar{m}_1)}; \nu, M \right) \int_0^1 \frac{\sqrt{1 - \eta_0} d\eta_0}{\left(x_q^{(m_1, \bar{m}_1)} - \eta_0 \right)^2} \\
 &- \frac{s_1}{\ell} \left[\frac{\partial}{\partial \eta_0} g_s^{(m_1)} (\eta_0) I_r^{(n)} \left(\bar{\xi}_p^{(n_1)}, x_q^{(m_1, \bar{m}_1)}, \eta_0; \nu, M \right) \right] \int_{\eta_0 = x_q^{(m_1, \bar{m}_1)}}^1 \frac{\sqrt{1 - \eta_0} d\eta_0}{\left(x_q^{(m_1, \bar{m}_1)} - \eta_0 \right)} \\
 &+ \left\{ \frac{s_1 \ell}{\left(x_q^{(m_1, \bar{m}_1)} \right)^2} F_r^{(n)} \left(\bar{\xi}_p^{(n_1)}, 0; \frac{\nu c_1 \left(z_q^{(m_1, \bar{m}_1)} \right)}{\ell}, M \right) \right. \\
 &\quad \left. \times \int_0^1 \left(g_s^{(m_1)} (\eta_0) - g_s^{(m_1)} \left(x_q^{(m_1, \bar{m}_1)} \right) \right) \log \left| x_q^{(m_1, \bar{m}_1)} - \eta_0 \right| \sqrt{1 - \eta_0} d\eta_0 \right. \\
 &\quad \left. + g_s^{(m_1)} \left(x_q^{(m_1, \bar{m}_1)} \right) \int_0^1 \log \left| x_q^{(m_1, \bar{m}_1)} - \eta_0 \right| \sqrt{1 - \eta_0} d\eta_0 \right\} \quad (3-24)
 \end{aligned}$$

With the particular form of $F_r^{(n)}(\xi, 0; u, M)$ given in formula (3-23), used in the definition (3-22) of the function $I_r^{(n)}(\bar{\xi}_p^{(n)}, x_q^{(m)}, \bar{m}_1, \eta_0; v, M)$, the quantity

$$\frac{1}{(x_q^{(m)}, \bar{m}_1) - \eta_0} \left\{ \begin{aligned} &g_s^{(m_1)} (\eta_0) I_r^{(n)} * (\bar{\xi}_p^{(n)}, x_q^{(m)}, \bar{m}_1, \eta_0; v, M) \\ &- g_s^{(m_1)} (x_q^{(m)}, \bar{m}_1) I_r^{(n)} * (\bar{\xi}_p^{(n)}, x_q^{(m)}, \bar{m}_1, \eta_0; v, M) \\ &- (\eta_0 - x_q^{(m)}, \bar{m}_1) \left[\frac{\partial}{\partial \eta_0} (g_s^{(m_1)} (\eta_0) I_r^{(n)} * (\bar{\xi}_p^{(n)}, x_q^{(m)}, \bar{m}_1, \eta_0; v, M)) \right]_{\eta_0 = x_q^{(m)}, \bar{m}_1} \end{aligned} \right\} \quad (3-25)$$

is finite in the range (0,1) of η_0 , as is apparent from the development of $I_r^{(n)}(\bar{\xi}_p^{(n)}, x_q^{(m)}, \bar{m}_1, \eta_0; v, M)$ obtained from formulae (B-17) and (B-19) of Appendix B. The first integral on the right-hand side of formula (3-24) may therefore be evaluated using the Gaussian formula of numerical integration (3-1). On taking $\bar{m} = \bar{m}_1$ in formula (3-1) we get

$$\begin{aligned}
& \frac{s_1}{2} \int_0^1 \left\{ g_s^{(m_1)}(\eta_0) I_r^{(n)} \left(\bar{\xi}_p^{(n_1)}, x_q^{(m_1, \bar{m}_1)} \right), \eta_0; \nu, M \right\} - g_s^{(m_1)} \left(x_q^{(m_1, \bar{m}_1)} \right) I_r^{(n)} \left(\bar{\xi}_p^{(n_1)}, x_q^{(m_1, \bar{m}_1)} \right), x_q^{(m_1, \bar{m}_1)}; \nu, M \right\} \\
& - \left(\eta_0 - x_q^{(m_1, \bar{m}_1)} \right) \left[\frac{\partial}{\partial \eta_0} \left(g_s^{(m_1)}(\eta_0) I_r^{(n)} \left(\bar{\xi}_p^{(n_1)}, x_q^{(m_1, \bar{m}_1)} \right), \eta_0; \nu, M \right) \right]_{\eta_0 = x_q^{(m_1, \bar{m}_1)}} \left\{ \frac{\sqrt{1 - \eta_0} \, d\eta_0}{\left(x_q^{(m_1, \bar{m}_1)} - \eta_0 \right)^2} \right. \\
& - \frac{s_1}{2} \sum_{\substack{\bar{m}_1 \\ k=1 \\ k \neq a_{1q}}} \left\{ g_s^{(m_1)} \left(\zeta_k^{(\bar{m}_1)} \right) I_r^{(n)} \left(\bar{\xi}_p^{(n_1)}, x_q^{(m_1, \bar{m}_1)} \right), \zeta_k^{(\bar{m}_1)}; \nu, M \right\} \\
& - g_s^{(m_1)} \left(x_q^{(m_1, \bar{m}_1)} \right) I_r^{(n)} \left(\bar{\xi}_p^{(n_1)}, x_q^{(m_1, \bar{m}_1)} \right), x_q^{(m_1, \bar{m}_1)}; \nu, M \right\} \\
& - \left(\zeta_k^{(\bar{m}_1)} - x_q^{(m_1, \bar{m}_1)} \right) \left[\frac{\partial}{\partial \eta_0} \left(g_s^{(m_1)}(\eta_0) I_r^{(n)} \left(\bar{\xi}_p^{(n_1)}, x_q^{(m_1, \bar{m}_1)} \right), \eta_0; \nu, M \right) \right]_{\eta_0 = x_q^{(m_1, \bar{m}_1)}} \left\{ \frac{\zeta_k^{(\bar{m}_1)}}{\left(x_q^{(m_1, \bar{m}_1)} - \zeta_k^{(\bar{m}_1)} \right)^2} \right. \\
& + \frac{s_1}{2\lambda} \bar{G}_{a_{1q}}^{(\bar{m}_1)} \left[\frac{\partial^2}{\partial \eta_0^2} \left(g_s^{(m_1)}(\eta_0) I_r^{(n)} \left(\bar{\xi}_p^{(n_1)}, x_q^{(m_1, \bar{m}_1)} \right), \eta_0; \nu, M \right) \right]_{\eta_0 = x_q^{(m_1, \bar{m}_1)}}
\end{aligned} \tag{3-26}$$

The quantity

$$\left(g_s^{(m_1)}(\eta_0) - g_s^{(m_1)}(\chi_q^{(m_1, \bar{m}_1)}) \right) \log \left| \chi_q^{(m_1, \bar{m}_1)} - \eta_0 \right| \quad (3-27)$$

also is finite in the range (0,1) of η_0 and so we may use the Gaussian formula of integration (3-1) to evaluate the integral on the right-hand side of formula (3-24) containing it. On taking $\bar{m} = m_1$ in formula (3-1) we get

$$\int_0^1 \left(g_s^{(m_1)}(\eta_0) - g_s^{(m_1)}(\chi_q^{(m_1, \bar{m}_1)}) \right) \log \left| \chi_q^{(m_1, \bar{m}_1)} - \eta_0 \right| \sqrt{1 - \eta_0} \\ = \sum_{\substack{k=1 \\ k \neq a_1 q}}^{\bar{m}_1} \bar{G}_k^{(\bar{m}_1)} \left\{ g_s^{(m_1)}(\tau_k^{(\bar{m}_1)}) - g_s^{(m_1)}(\chi_q^{(m_1, \bar{m}_1)}) \right\} \log \left| \chi_q^{(m_1, \bar{m}_1)} - \tau_k^{(\bar{m}_1)} \right| \quad (3-28)$$

The integration formula

$$\int_0^1 \log \left| \eta - \eta_0 \right| \sqrt{1 - \eta_0} d\eta_0 = \frac{2}{3} \log |\eta| + \frac{2}{3} (1 - \eta)^{\frac{2}{3}} \log \left(\frac{1 + \sqrt{1 - \eta}}{1 - \sqrt{1 - \eta}} \right) - \frac{4}{3} (1 - \eta) - \frac{4}{9} \quad (3-29)$$

and the principle value integration formulae

$$\int_0^1 \frac{\sqrt{1 - \eta_0}}{(\eta - \eta_0)} d\eta_0 = 2 - \sqrt{1 - \eta} \log \left(\frac{1 + \sqrt{1 - \eta}}{1 - \sqrt{1 - \eta}} \right) \quad (3-30)$$

$$\int_0^1 \frac{\sqrt{1 - \eta_0}}{(\eta - \eta_0)^2} d\eta_0 = -\frac{1}{\eta} - \frac{1}{2\sqrt{1 - \eta}} \log \left(\frac{1 + \sqrt{1 - \eta}}{1 - \sqrt{1 - \eta}} \right) \quad (3-31)$$

have been derived in Appendix E.

If we substitute the numerical integration formulae (3-26) and (3-28), and the analytical integration formulae (3-29), (3-30) and (3-31), as appropriate, into the right-hand side of formula (3-24) we get the result

$$\begin{aligned}
 & v_{r,s}^{(1,1)} \left(z_{p,q}^{(m_1, \bar{m}_1)}, z_q^{(m_1, \bar{m}_1)}; \nu, M \right) \\
 &= \frac{s_1}{l} \sum_{\substack{\bar{m}_1 \\ k=1 \\ k \neq a_1 q}} \frac{\bar{C}_k^{(\bar{m}_1)} g_s^{(m_1)}(\zeta_k^{(\bar{m}_1)})}{\left(x_q^{(m_1, \bar{m}_1)} - \zeta_k^{(\bar{m}_1)} \right)^2} I_r^{(n)} \left(\bar{z}^{(n_1)}, x_q^{(m_1, \bar{m}_1)}, \zeta_k^{(\bar{m}_1)}; \nu, M \right) \\
 &\quad - \frac{s_1}{l} g_s^{(m_1)} \left(x_q^{(m_1, \bar{m}_1)} \right) I_r^{(n)*} \left(\bar{z}^{(n_1)}, x_q^{(m_1, \bar{m}_1)}, x_q^{(m_1, \bar{m}_1)}; \nu, M \right) \left[\sum_{\substack{\bar{m}_1 \\ k=1 \\ k \neq a_1 q}} \frac{\bar{C}_k^{(\bar{m}_1)}}{\left(x_q^{(m_1, \bar{m}_1)} - \zeta_k^{(\bar{m}_1)} \right)^2} + \frac{1}{x_q^{(m_1, \bar{m}_1)}} + \frac{1}{2\sqrt{1-x_q^{(m_1, \bar{m}_1)}}} \log \left(\frac{1 + \sqrt{1-x_q^{(m_1, \bar{m}_1)}}}{1 - \sqrt{1-x_q^{(m_1, \bar{m}_1)}}} \right) \right] \\
 &\quad + \frac{s_1}{l} \left[\frac{\partial}{\partial \nu_0} \eta_0 g_s^{(m_1)} \left(\nu_0 \right) I_r^{(n)*} \left(\bar{z}^{(n_1)}, x_q^{(m_1, \bar{m}_1)}, \nu_0; \nu, M \right) \right]_{\nu_0 = x_q^{(m_1, \bar{m}_1)}} \\
 &\quad + \frac{s_1}{2l} \bar{C}_k^{(\bar{m}_1)} \left[\frac{\partial^2}{\partial \nu_0^2} g_s^{(m_1)} \left(\nu_0 \right) I_r^{(n)*} \left(\bar{z}^{(n_1)}, x_q^{(m_1, \bar{m}_1)}, \nu_0; \nu, M \right) \right]_{\nu_0 = x_q^{(m_1, \bar{m}_1)}} \\
 &\quad + \frac{s_1}{l} \left\{ \frac{F_r^{(n)} \left(\bar{z}^{(n_1)}, 0; \frac{\nu c_1 \left(z_q^{(m_1, \bar{m}_1)} \right)}{l} \right)}{\left(z_q^{(m_1, \bar{m}_1)} \right)^2} \right\} \left\{ \frac{M g_s^{(m_1)} \left(x_q^{(m_1, \bar{m}_1)} \right)}{x_q^{(m_1, \bar{m}_1)}} \right\} \left[- \sum_{\substack{\bar{m}_1 \\ k=1 \\ k \neq a_1 q}} \bar{C}_k^{(\bar{m}_1)} \log \left| \zeta_k^{(\bar{m}_1)} - x_q^{(m_1, \bar{m}_1)} \right| + \frac{2}{3} \log \left(x_q^{(m_1, \bar{m}_1)} \right) \right. \\
 &\quad \left. + \frac{2}{3} \left(1 - x_q^{(m_1, \bar{m}_1)} \right)^{\frac{1}{2}} \log \left(\frac{1 + \sqrt{1-x_q^{(m_1, \bar{m}_1)}}}{1 - \sqrt{1-x_q^{(m_1, \bar{m}_1)}}} \right) - \frac{4}{3} \left(1 - x_q^{(m_1, \bar{m}_1)} \right) - \frac{4}{9} \right]
 \end{aligned}$$

..... (3-32)

We use the formula (3-32) for $w_{r,s}^{(1,1)}(\bar{x}_{pq}^{(n'_1, m'_1, \bar{m}_1)}, z_q^{(m'_1, \bar{m}_1)}; \nu, M)$ to get $\psi_{i,j;r,s}^{(1,1)}$ from formula (3-16). In order to be able to use formula (3-32) we must be able to evaluate the quantities

$$\left. \begin{aligned} I_r^{(n)}(\bar{\xi}_p^{(n'_1)}, \chi_q^{(m'_1, \bar{m}_1)}, \zeta_k^{(\bar{m}_1)}; \nu, M) \quad k \neq a_{1q} \\ I_r^{(n)*}(\bar{\xi}_p^{(n'_1)}, \chi_q^{(m'_1, \bar{m}_1)}, \chi_q^{(m'_1, \bar{m}_1)}; \nu, M) \end{aligned} \right\} \quad (3-33)$$

$$\left[\frac{\partial}{\partial \eta_0} I_r^{(n)*}(\bar{\xi}_p^{(n'_1)}, \chi_q^{(m'_1, \bar{m}_1)}, \eta_0; \nu, M) \right]_{\eta_0 = \chi_q^{(m'_1, \bar{m}_1)}} \quad (3-34)$$

and

$$\left[\frac{\partial^2}{\partial \eta_0^2} I_r^{(n)*}(\bar{\xi}_p^{(n'_1)}, \chi_q^{(m'_1, \bar{m}_1)}, \eta_0; \nu, M) \right]_{\eta_0 = \chi_q^{(m'_1, \bar{m}_1)}} \quad (3-35)$$

The quantities (3-33) are obtained from formula (3-21) by using numerical integration, the number of integration points being taken large enough for any desired accuracy to be attained. When $\eta_0 = \chi_q^{(m'_1, \bar{m}_1)}$ the formula (3-21) reduces to formula (B-70) of Appendix B. Tractable expressions for the quantities (3-34) and (3-35) are derived in Appendix B and are given in formulae (B-71) and (B-73). Tractable expressions allied to these were obtained by Lehrian and Gamer¹². Their forms are different from ours, but they are entirely equivalent. Because of differences in both form and notation it was thought that the derivation in Appendix B in the spirit of the present Report would be helpful to a reader. The original derivation for steady flow was given by Zandbergen, Labrujere and Wouters¹³.

3.2 Evaluation of $\psi_{i,j;r,s}^{(2,2)}$

We apply the numerical formulae of integration (3-7) and (3-12) to the evaluation of $\psi_{i,j;r,s}^{(2,2)}$ from formula (2-101). On taking $m' = m'_2$, $n' = n'_2$ and

$$\bar{m} = \bar{m}_2 = a_2(m'_2 + 1) - 1 \quad (3-36)$$

where a_2 is some positive integer, we get the result

$$\psi_{i,j;r,s}^{(2,2)} = \frac{s_2}{4\pi l} \sum_{p=1}^{n_2'} \sum_{q=1}^{m_2'} H_p^{(n_2')} G_q^{(m_2', \bar{m}_2)} h_i^{(n)} \left(\xi_p^{(n_2')} \right) g_j^{(m_2)} \left(\chi_q^{(m_2', \bar{m}_2)} \right) \times w_{r,s}^{(2,2)} \left(\bar{x}_{p,q}^{(n_2', m_2', \bar{m}_2)}, u_q^{(m_2', \bar{m}_2)}; \nu, M \right) \quad (3-37)$$

where

$$\bar{x}_{p,q}^{(n_2', m_2', \bar{m}_2)} = c_2 \left(u_q^{(m_2', \bar{m}_2)} \right) \bar{\xi}_p^{(n_2')} + e_2 \left(u_q^{(m_2', \bar{m}_2)} \right) \quad (3-38)$$

$$u_q^{(m_2', \bar{m}_2)} = s_2 \chi_q^{(m_2', \bar{m}_2)} \quad (3-39)$$

$$\bar{\xi}_p^{(n_2')} = 1 - \xi_p^{(n_2')} \quad (3-40)$$

We now evaluate $w_{r,s}^{(2,2)} \left(\bar{x}_{p,q}^{(n_2', m_2', \bar{m}_2)}, u_q^{(m_2', \bar{m}_2)}; \nu, M \right)$ from formula (2-73), which we take in the form

$$w_{r,s}^{(2,2)} \left(\bar{x}_{p,q}^{(n_2', m_2', \bar{m}_2)}, u_q^{(m_2', \bar{m}_2)}; \nu, M \right) = \frac{s_2}{l} \int_0^1 g_s^{(m_2)}(\eta_0) J_r^{(n)} \left(\bar{\xi}_p^{(n_2')}, \chi_q^{(m_2', \bar{m}_2)}, \eta_0; \nu, M \right) \frac{\sqrt{1-\eta_0}}{\left(\chi_q^{(m_2', \bar{m}_2)} - \eta_0 \right)^2} d\eta_0 \quad (3-41)$$

where

$$J_r^{(n)} \left(\bar{\xi}_p^{(n_2')}, \chi_q^{(m_2', \bar{m}_2)}, \eta_0; \nu, M \right) = \left(\chi_q^{(m_2', \bar{m}_2)} - \eta_0 \right)^2 \int_0^1 h_r^{(n)}(\xi_0) K_1 \left(\frac{\bar{x}_{p,q}^{(n_2', m_2', \bar{m}_2)} - x_0}{l}, \frac{u_q^{(m_2', \bar{m}_2)} - u_0}{l}; \nu, M \right) \sqrt{\frac{1-\xi_0}{\xi_0}} d\xi_0 \dots (3-42)$$

We define the function $J_r^{(n)*} \left(\bar{\xi}_p^{(n_2')}, \chi_q^{(m_2', \bar{m}_2)}, \eta_0; \nu, M \right)$ by means of the formula

$$\begin{aligned}
 & J_r^{(n)*} \left(\bar{\xi}_p^{(n_2')}, \chi_q^{(m_2', \bar{m}_2)}, \eta_0; \nu, M \right) \\
 &= J_r^{(n)} \left(\bar{\xi}_p^{(n_2')}, \chi_q^{(m_2', \bar{m}_2)}, \eta_0; \nu, M \right) \\
 &\quad - \left(\frac{\ell}{c_2(u_q^{(m_2', \bar{m}_2)})} \right)^2 \left(\chi_q^{(m_2', \bar{m}_2)} - \eta_0 \right)^2 \log \left| \chi_q^{(m_2', \bar{m}_2)} - \eta_0 \right| F_r^{(n)} \left(\bar{\xi}_p^{(n_2')}, 0; \frac{\nu c_2(u_q^{(m_2', \bar{m}_2)})}{\ell}, M \right) \\
 & \hspace{15em} \dots\dots (3-42a)
 \end{aligned}$$

where $F_r^{(n)}(\xi, 0; \nu, M)$ is given by formula (3-23).

The formula (3-41) is analogous to the formula (3-20) and we evaluate it similarly to get

$$\begin{aligned}
 & w_{r,s}^{(2,2)} \left(\bar{x}_{p,q}^{(n_2', m_2', \bar{m}_2)}, u_q^{(m_2', \bar{m}_2)}; \nu, M \right) \\
 &= \frac{s_2}{\ell} \sum_{\substack{k=1 \\ k \neq a_{2q}}}^{\bar{m}_2} \frac{\bar{G}_k^{(\bar{m}_2)} g_s^{(m_2)}(\zeta_k^{(\bar{m}_2)})}{\left(\chi_q^{(m_2', \bar{m}_2)} - \zeta_k^{(\bar{m}_2)} \right)^2} J_r^{(n)} \left(\bar{\xi}_p^{(n_2')}, \chi_q^{(m_2', \bar{m}_2)}, \zeta_k^{(\bar{m}_2)}; \nu, M \right) \\
 &\quad - \frac{s_2}{\ell} g_s^{(m_2)} \left(\chi_q^{(m_2', \bar{m}_2)} \right) J_r^{(n)*} \left(\bar{\xi}_p^{(n_2')}, \chi_q^{(m_2', \bar{m}_2)}, \chi_q^{(m_2', \bar{m}_2)}; \nu, M \right) \\
 &\quad \times \left[\sum_{\substack{k=1 \\ k \neq a_{2q}}}^{\bar{m}_2} \frac{\bar{G}_k^{(\bar{m}_2)}}{\left(\chi_q^{(m_2', \bar{m}_2)} - \zeta_k^{(\bar{m}_2)} \right)^2} + \frac{1}{\chi_q^{(m_2', \bar{m}_2)}} + \frac{1}{2\sqrt{1-\chi_q^{(m_2', \bar{m}_2)}}} \log \left(\frac{1 + \sqrt{1-\chi_q^{(m_2', \bar{m}_2)}}}{1 - \sqrt{1-\chi_q^{(m_2', \bar{m}_2)}}} \right) \right] \\
 &\quad + \frac{s_2}{\ell} \left[\frac{\partial}{\partial \eta_0} \left(g_s^{(m_2)}(\eta_0) J_r^{(n)*} \left(\bar{\xi}_p^{(n_2')}, \chi_q^{(m_2', \bar{m}_2)}, \eta_0; \nu, M \right) \right) \right]_{\eta_0 = \chi_q^{(m_2', \bar{m}_2)}} \\
 &\quad \times \left[\sum_{\substack{k=1 \\ k \neq a_{2q}}}^{\bar{m}_2} \frac{\bar{G}_k^{(\bar{m}_2)}}{\left(\chi_q^{(m_2', \bar{m}_2)} - \zeta_k^{(\bar{m}_2)} \right)} - 2 + \sqrt{1-\chi_q^{(m_2', \bar{m}_2)}} \log \left(\frac{1 + \sqrt{1-\chi_q^{(m_2', \bar{m}_2)}}}{1 - \sqrt{1-\chi_q^{(m_2', \bar{m}_2)}}} \right) \right]
 \end{aligned}$$

$$\begin{aligned}
& + \frac{s_2}{2\ell} \bar{G}_{a_2q}^{(\bar{m}_2)} \left[\frac{\partial^2}{\partial \eta_0^2} \left(g_s^{(m_2)}(\eta_0) J_r^{(n)*} \left(\bar{\xi}_p^{(n_2')}, \chi_q^{(m_2', \bar{m}_2)}, \eta_0; \nu, M \right) \right) \right]_{\eta_0 = \chi_q^{(m_2', \bar{m}_2)}} \\
& + \frac{s_2 \ell}{\left\{ c_2 \left(u_q^{(m_2', \bar{m}_2)} \right) \right\}^2} F_r^{(n)} \left(\bar{\xi}_p^{(n_2')}, 0, \frac{\nu c_2 \left(u_q^{(m_2', \bar{m}_2)} \right)}{\ell}, M \right) g_s^{(m_2)} \left(\chi_q^{(m_2', \bar{m}_2)} \right) \\
& \times \left[- \sum_{\substack{k=1 \\ k \neq a_2q}}^{\bar{m}_2} \bar{G}_k^{(\bar{m}_2)} \log \left| \zeta_k^{(\bar{m}_2)} - \chi_q^{(m_2', \bar{m}_2)} \right| + \frac{2}{3} \log \left(\chi_q^{(m_2', \bar{m}_2)} \right) \right. \\
& \left. + \frac{2}{3} \left(1 - \chi_q^{(m_2', \bar{m}_2)} \right)^{\frac{3}{2}} \log \left(\frac{1 + \sqrt{1 - \chi_q^{(m_2', \bar{m}_2)}}}{1 - \sqrt{1 - \chi_q^{(m_2', \bar{m}_2)}}} \right) - \frac{4}{3} \left(1 - \chi_q^{(m_2', \bar{m}_2)} \right) - \frac{4}{9} \right]. \quad (3-43)
\end{aligned}$$

We use the formula (3-43) for $w_{r,s}^{(2,2)} \left(\bar{\xi}_p^{(n_2')}, \chi_q^{(m_2', \bar{m}_2)}, u_q^{(m_2', \bar{m}_2)}; \nu, M \right)$ to get $\psi_{i,j;r,s}^{(2,2)}$ from formula (3-37). In order to be able to use formula (3-43) we must be able to evaluate the quantities.

$$\left. \begin{aligned}
& J_r^{(n)} \left(\bar{\xi}_p^{(n_2')}, \chi_q^{(m_2', \bar{m}_2)}, \zeta_k^{(\bar{m}_2)}; \nu, M \right) \quad k \neq a_2q \\
& J_r^{(n)*} \left(\bar{\xi}_p^{(n_2')}, \chi_q^{(m_2', \bar{m}_2)}, \chi_q^{(m_2', \bar{m}_2)}; \nu, M \right)
\end{aligned} \right\} \quad (3-44)$$

$$\left[\frac{\partial}{\partial \eta_0} J_r^{(n)*} \left(\bar{\xi}_p^{(n_2')}, \chi_q^{(m_2', \bar{m}_2)}, \eta_0; \nu, M \right) \right]_{\eta_0 = \chi_q^{(m_2', \bar{m}_2)}} \quad (3-45)$$

and

$$\left[\frac{\partial^2}{\partial \eta_0^2} J_r^{(n)*} \left(\bar{\xi}_p^{(n_2')}, \chi_q^{(m_2', \bar{m}_2)}, \eta_0; \nu, M \right) \right]_{\eta_0 = \chi_q^{(m_2', \bar{m}_2)}} \quad (3-46)$$

The quantities (3-44) are obtained from (3-42) by using numerical integration. Formulae analogous to (B-70), (B-71) and (B-73) of Appendix B are used to evaluate the quantities (3-44) when $\zeta_k^{(\bar{m}_2)} = \chi_q^{(m_2', \bar{m}_2)}$ and the quantities (3-45) and (3-46) respectively.

3.3 Evaluation of $\psi_{i,j;r,s}^{(1,2)}$

We apply the numerical formulae of integration (3-7) and (3-12) to the evaluation of $\psi_{i,j;r,s}^{(1,2)}$ from formula (2-99). On taking $m' = m_1'$, $n' = n_1'$ and

$$\bar{m} = \bar{m}_1 = a_1(m_1' + 1) - 1 \quad (3-47)$$

we get the result

$$\psi_{i,j;r,s}^{(1,2)} = \frac{s_1}{4\pi l} \sum_{p=1}^{n_1'} \sum_{q=1}^{m_1'} H_p^{(n_1')} G_q^{(m_1', \bar{m}_1)} h_i^{(n)} \left(\xi_p^{(n_1')} \right) g_j^{(m_1)} \left(\chi_q^{(m_1', \bar{m}_1)} \right) \times w_{r,s}^{(1,2)} \left(\bar{x}_{p,q}^{(n_1', m_1', \bar{m}_1)}, z_q^{(m_1', \bar{m}_1)}; \nu, M \right) \quad (3-48)$$

where $\bar{x}_{p,q}^{(n_1', m_1', \bar{m}_1)}$ and $z_q^{(m_1', \bar{m}_1)}$ are defined in formulae (3-17) and (3-18)

Let us note here that the functions $w_{r,s}^{(1,1)}(x,z;\nu,M)$ and $w_{r,s}^{(1,2)}(x,z;\nu,M)$, given by formulae (2-70) and (2-71) respectively, are both infinite at $z = 0$, whereas $\hat{w}_q^{(1)}(x,z)$ given by formula (2-68) is expected to be finite at $z = 0$. In view of formulae (2-68) it would seem wise to evaluate $w_{r,s}^{(1,1)}(x,z;\nu,M)$ and $w_{r,s}^{(1,2)}(x,z;\nu,M)$ at the same points (x,z) , and this is why the integration formula (3-7) rather than the more accurate integration formula (3-1) has been used for the spanwise integration in getting the expression (3-48) for $\psi_{i,j;r,s}^{(1,2)}$.

We now use the expression (2-21) for the kernel function $K_2(x,u,\nu,\theta,\nu,M)$ in formula (2-71) to get

$$\begin{aligned}
& w_{r,s}^{(1,2)} \left(\bar{x}_{p,q}^{(n'_1, m'_1, \bar{m}_1)}, z_q^{(m'_1, \bar{m}_1)}; \nu, M \right) \\
&= -s_2 \ell \sin \alpha \int_0^1 g_s^{(m_2)}(\eta_0) M_r^{(n)} \left(\bar{\xi}_p^{(n'_1)}, \chi_q^{(m'_1, \bar{m}_1)}, \eta_0; \nu, M \right) \\
&\quad \times \frac{\sqrt{1-\eta_0} d\eta_0}{\left[s_2^2 \eta_0^2 + 2s_1 s_2 \eta_0 \chi_q^{(m'_1, \bar{m}_1)} \sin \alpha + \left(s_1 \chi_q^{(m'_1, \bar{m}_1)} \right)^2 \right]} \\
&= -s_2 \ell (\cos \alpha)^2 \int_0^1 g_s^{(m_2)}(\eta_0) N_r^{(n)} \left(\bar{\xi}_p^{(n'_1)}, \chi_q^{(m'_1, \bar{m}_1)}, \eta_0; \nu, M \right) \\
&\quad \times \frac{s_1 s_2 \eta_0 \chi_q^{(m'_1, \bar{m}_1)} \sqrt{1-\eta_0} d\eta_0}{\left[s_2^2 \eta_0^2 + 2s_1 s_2 \eta_0 \chi_q^{(m'_1, \bar{m}_1)} \sin \alpha + \left(s_1 \chi_q^{(m'_1, \bar{m}_1)} \right)^2 \right]^2} \\
&\quad \dots\dots (3-49)
\end{aligned}$$

where

$$\begin{aligned}
& M_r^{(n)} \left(\bar{\xi}_p^{(n'_1)}, \chi_q^{(m'_1, \bar{m}_1)}, \eta_0; \nu, M \right) \\
&= \frac{1}{\ell^2} \left[s_2^2 \eta_0^2 + 2s_1 s_2 \eta_0 \chi_q^{(m'_1, \bar{m}_1)} \sin \alpha + \left(s_1 \chi_q^{(m'_1, \bar{m}_1)} \right)^2 \right] \\
&\quad \times \int_0^1 h_r^{(n)}(\xi_0) K_1 \left(\frac{\bar{x}_{p,q}^{(n'_1, m'_1, \bar{m}_1)} - x_0}{\ell} \right. \\
&\quad \left. \frac{\left[s_2^2 \eta_0^2 + 2s_1 s_2 \eta_0 \chi_q^{(m'_1, \bar{m}_1)} \sin \alpha + \left(s_1 \chi_q^{(m'_1, \bar{m}_1)} \right)^2 \right]^{\frac{1}{2}}}{\ell}; \nu, M \right) \sqrt{\frac{1-\xi_0}{\xi_0}} d\xi_0 \\
&\quad \dots\dots (3-50)
\end{aligned}$$

and

$$\begin{aligned}
 & N_r^{(n)}\left(\bar{\xi}_p^{(n_1')}, \chi_q^{(m_1', \bar{m}_1)}, \eta_0; \nu, M\right) \\
 &= \frac{1}{\ell^4} \left[s_2^2 \eta_0^2 + 2s_1 s_2 \eta_0 \chi_q^{(m_1', \bar{m}_1)} \sin \alpha + \left(s_1 \chi_q^{(m_1', \bar{m}_1)} \right)^2 \right]^2 \\
 & \times \int_0^1 h_r^{(n)}(\xi_0) F\left(\frac{\bar{x}_{p,q}^{(n_1', m_1', \bar{m}_1)} - x_0}{\ell} \right. \\
 & \quad \left. \frac{\left[s_2^2 \eta_0^2 + 2s_1 s_2 \eta_0 \chi_q^{(m_1', \bar{m}_1)} \sin \alpha + \left(s_1 \chi_q^{(m_1', \bar{m}_1)} \right)^2 \right]^{\frac{1}{2}}}{\ell} ; \nu, M \right) \sqrt{\frac{1-\xi_0}{\xi_0}} d\xi_0.
 \end{aligned}$$

..... (3-51)

Let us write

$$\begin{aligned}
 & g_s^{(m_2)}(\eta_0) M_r^{(n)}\left(\bar{\xi}_p^{(n_1')}, \chi_q^{(m_1', \bar{m}_1)}, \eta_0; \nu, M\right) \\
 &= \sum_{\ell=1}^{\bar{m}_2} g_s^{(m_2)}\left(\zeta_\ell^{(\bar{m}_2)}\right) M_r^{(n)}\left(\bar{\xi}_p^{(n_1')}, \chi_q^{(m_1', \bar{m}_1)}, \zeta_\ell^{(\bar{m}_2)}; \nu, M\right) \bar{g}_\ell^{(\bar{m}_2)}(\eta_0) \quad (3-52)
 \end{aligned}$$

and

$$\begin{aligned}
 & g_s^{(m_2)}(\eta_0) N_r^{(n)}\left(\bar{\xi}_p^{(n_1')}, \chi_q^{(m_1', \bar{m}_1)}, \eta_0; \nu, M\right) \\
 &= \sum_{\ell=1}^{\bar{m}_2} g_s^{(m_2)}\left(\zeta_\ell^{(\bar{m}_2)}\right) N_r^{(n)}\left(\bar{\xi}_p^{(n_1')}, \chi_q^{(m_1', \bar{m}_1)}, \zeta_\ell^{(\bar{m}_2)}; \nu, M\right) \bar{g}_\ell^{(\bar{m}_2)}(\eta_0) \quad (3-53)
 \end{aligned}$$

where the $\bar{g}_\ell^{(\bar{m})}(\eta_0)$, $\ell = 1(1)\bar{m}$, are the interpolation polynomials of degree $(\bar{m}-1)$ in η_0 given by the formulae

$$\bar{g}_\ell^{(\bar{m})}(\eta_0) = \prod_{\substack{k=1 \\ k \neq \ell}}^{\bar{m}} \left(\frac{\eta_0 - \zeta_k^{(\bar{m})}}{\zeta_\ell^{(\bar{m})} - \zeta_k^{(\bar{m})}} \right) \quad \ell = 1(1)\bar{m}, \quad (3-54)$$

and the points $\zeta_k^{(\bar{m})}$, $k = 1(1)\bar{m}$, are the integration points (3-2).

On substituting for $g_s^{(m_2)}(\eta_0) M_r^{(n)}(\bar{\xi}_p^{(n_1')}, \chi_q^{(m_1', \bar{m}_1)}, \eta_0; \nu, M)$ and $g_s^{(m_2)}(\eta_0) N_r^{(n)}(\bar{\xi}_p^{(n_1')}, \chi_q^{(m_1', \bar{m}_1)}, \eta_0; \nu, M)$ from (3-52) and (3-53) respectively into the right-hand side of formula (3-49) we get

$$\begin{aligned} & w_{r,s}^{(1,2)}(\bar{x}_{p,q}^{(n_1', m_1', \bar{m}_1)}, z_q^{(m_1', \bar{m}_1)}; \nu, M) \\ &= -s_2^\ell \sin \alpha \sum_{\ell=1}^{\bar{m}_2} g_s^{(m_2)}(\zeta_\ell^{(\bar{m}_2)}) M_r^{(n)}(\bar{\xi}_p^{(n_1')}, \chi_q^{(m_1', \bar{m}_1)}, \zeta_\ell^{(\bar{m}_2)}; \nu, M) \\ & \quad \times \int_0^1 \frac{g_\ell^{(\bar{m}_2)}(\eta_0) \sqrt{1-\eta_0} d\eta_0}{\left[s_2^2 \eta_0^2 + 2s_1 s_2 \eta_0 \chi_q^{(m_1', \bar{m}_1)} \sin \alpha + \left(s_1 \chi_q^{(m_1', \bar{m}_1)} \right)^2 \right]} \\ & - s_2^\ell (\cos \alpha)^2 \sum_{\ell=1}^{\bar{m}_2} g_s^{(m_2)}(\zeta_\ell^{(\bar{m}_2)}) N_r^{(n)}(\bar{\xi}_p^{(n_1')}, \chi_q^{(m_1', \bar{m}_1)}, \zeta_\ell^{(\bar{m}_2)}; \nu, M) \\ & \quad \times \int_0^1 \frac{s_1 s_2 \eta_0 \chi_q^{(m_1', \bar{m}_1)} g_\ell^{(\bar{m}_2)}(\eta_0) \sqrt{1-\eta_0} d\eta_0}{\left[s_2^2 \eta_0^2 + 2s_1 s_2 \eta_0 \chi_q^{(m_1', \bar{m}_1)} \sin \alpha + \left(s_1 \chi_q^{(m_1', \bar{m}_1)} \right)^2 \right]^2} \dots (3-55) \end{aligned}$$

We use the formula (3-55) for $w_{r,s}^{(1,2)}(\bar{x}_{p,q}^{(n_1', m_1', \bar{m}_1)}, z_q^{(m_1', \bar{m}_1)}; \nu, M)$ to get $\psi_{i,j;r,s}^{(1,2)}$ from formula (3-48). To use formula (3-55) we need to evaluate the quantities

$$M_r^{(n)}(\bar{\xi}_p^{(n_1')}, \chi_q^{(m_1', \bar{m}_1)}, \zeta_\ell^{(\bar{m}_2)}; \nu, M), \quad (3-56)$$

$$N_r^{(n)}(\bar{\xi}_p^{(n_1')}, \chi_q^{(m_1', \bar{m}_1)}, \zeta_\ell^{(\bar{m}_2)}; \nu, M), \quad (3-57)$$

$$\ell^2 \int_0^1 \frac{\bar{g}_\ell^{(\bar{m}_2)}(\eta_0) \sqrt{1-\eta_0} d\eta_0}{\left[s_2^2 \eta_0^2 + 2s_1 s_2 \eta_0 \chi_q^{(m'_1, \bar{m}_1)} \sin \alpha + \left(s_1 \chi_j^{(m'_1, \bar{m}_1)} \right)^2 \right]} \quad (3-58)$$

and

$$\ell^2 \int_0^1 \frac{s_1 s_2 \eta_0 \chi_q^{(m'_1, \bar{m}_1)} \bar{g}_\ell^{(\bar{m}_2)}(\eta_0) \sqrt{1-\eta_0} d\eta_0}{\left[s_2^2 \eta_0^2 + 2s_1 s_2 \eta_0 \chi_q^{(m'_1, \bar{m}_1)} \sin \alpha + \left(s_1 \chi_q^{(m'_1, \bar{m}_1)} \right)^2 \right]^2} \quad (3-59)$$

The quantities (3-56) and (3-57) are obtained from formulae (3-50) and (3-51) respectively by using numerical integration in ξ_0 and the quantities (3-58) and (3-59) are evaluated by using numerical integration in η_0 .

3.4 Evaluation of $\psi_{i,j;r,s}^{(2,1)}$ and $\psi_{i,j;r,s}^{(2,3)}$

We apply the numerical formulae of integration (3-7) and (3-12) to the evaluation of $\psi_{i,j;r,s}^{(2,1)}$ and $\psi_{i,j;r,s}^{(2,3)}$ from formulae (2-100) and (2-102) respectively. On taking $m' = m'_2$, $n' = n'_2$ and

$$\bar{m} = \bar{m}_2 = a_2(m'_2 + 1) - 1 \quad (3-60)$$

we get the results

$$\begin{aligned} \psi_{i,j;r,s}^{(2,1)} &= \frac{s_2}{4\pi\ell} \sum_{p=1}^{n'_2} \sum_{q=1}^{m'_2} H_p^{(n'_2)} G_q^{(m'_2, \bar{m}_2)} h_i^{(n)} \left(\xi_p^{(n'_2)} \right) g_j^{(m_2)} \left(\chi_q^{(m'_2, \bar{m}_2)} \right) \\ &\quad \times w_{r,s}^{(2,1)} \left(\bar{x}_{p,q}^{(n'_2, m'_2, \bar{m}_2)}, u_q^{(m'_2, \bar{m}_2)}; v, M \right) \end{aligned} \quad (3-61)$$

and

$$\begin{aligned} \psi_{i,j;r,s}^{(2,3)} &= \frac{s_2}{4\pi\ell} \sum_{p=1}^{n'_2} \sum_{q=1}^{m'_2} H_p^{(n'_2)} G_q^{(m'_2, \bar{m}_2)} h_i^{(n)} \left(\xi_p^{(n'_2)} \right) g_j^{(m_2)} \left(\chi_q^{(m'_2, \bar{m}_2)} \right) \\ &\quad \times w_{r,s}^{(2,3)} \left(\bar{x}_{p,q}^{(n'_2, m'_2, \bar{m}_2)}, u_q^{(m'_2, \bar{m}_2)}; v, M \right) \end{aligned} \quad (3-62)$$

where $\bar{x}_{p,q}^{(n'_2, m'_2, \bar{m}_2)}$ and $u_q^{(m'_2, \bar{m}_2)}$ are defined in formulae (3-38) and (3-39).

Again we note here that the functions $w_{r,s}^{(2,1)}(x,u;v,M)$, $w_{r,s}^{(2,2)}(x,u;v,M)$ and $w_{r,s}^{(2,3)}(x,u;v,M)$, given by formulae (2-72) to (2-74) respectively, are all infinite at $u = 0$, whereas $\hat{w}_q^{(2)}(x,u)$ given by formula (2-69) is expected to be finite at $u = 0$. In view of formula (2-69) it would seem wise to evaluate $w_{r,s}^{(2,1)}(x,u;v,M)$, $w_{r,s}^{(2,2)}(x,u;v,M)$ and $w_{r,s}^{(2,3)}(x,u;v,M)$ at the same points (x,u) and this is why the integration formula (3-7) rather than the more accurate integration formula (3-1) has been used for the spanwise integration in getting the expressions (3-61) and (3-62) for $\psi_{i,j;r,s}^{(2,1)}$ and $\psi_{i,j;r,s}^{(2,3)}$ respectively.

We now use the expression (2-21) for the kernel function $K_2(x,u,v;\theta,v,M)$ in formula (2-72) to get

$$\begin{aligned}
 & w_{r,s}^{(2,1)}\left(\bar{x}_{p,q}^{(n_2', m_2', \bar{m}_2)}, u_q^{(m_2', \bar{m}_2)}; v, M\right) \\
 &= -s_1 \ell \sin \alpha \int_0^1 g_s^{(m_1)}(\eta_0) P_r^{(n)}\left(\bar{\xi}_p^{(n_2')}, \chi_q^{(m_2', \bar{m}_2)}, \eta_0; v, M\right) \\
 &\quad \times \frac{\sqrt{1-\eta_0} d\eta_0}{\left[s_1^2 \eta_0^2 + 2s_1 s_2 \eta_0 \chi_q^{(m_2', \bar{m}_2)} \sin \alpha + \left(s_2 \chi_q^{(m_2', \bar{m}_2)}\right)^2\right]} \\
 &\quad - s_1 \ell (\cos \alpha)^2 \int_0^1 g_s^{(m_1)}(\eta_0) Q_r^{(n)}\left(\bar{\xi}_p^{(n_2')}, \chi_q^{(m_2', \bar{m}_2)}, \eta_0; v, M\right) \\
 &\quad \times \frac{s_1 s_2 \eta_0 \chi_q^{(m_2', \bar{m}_2)} \sqrt{1-\eta_0} d\eta_0}{\left[s_1^2 \eta_0^2 + 2s_1 s_2 \eta_0 \chi_q^{(m_2', \bar{m}_2)} \sin \alpha + \left(s_2 \chi_q^{(m_2', \bar{m}_2)}\right)^2\right]^2} \cdot (3-63)
 \end{aligned}$$

where

$$\begin{aligned}
 & P_r^{(n)} \left(\bar{\xi}_p^{(n_2')}, \chi_q^{(m_2', \bar{m}_2)}, \eta_0; \nu, M \right) \\
 &= \frac{1}{\ell^2} \left[s_1^2 \eta_0^2 + 2s_1 s_2 \eta_0 \chi_q^{(m_2', \bar{m}_2)} \sin \alpha + \left(s_2 \chi_q^{(m_2', \bar{m}_2)} \right)^2 \right] \\
 &\quad \times \int_0^1 h_r^{(n)}(\xi_0) K_1 \left(\frac{\bar{x}_{p,q}^{(n_2', m_2', \bar{m}_2)} - x_0}{\ell} \right), \\
 &\quad \left[\frac{s_1^2 \eta_0^2 + 2s_1 s_2 \eta_0 \chi_q^{(m_2', \bar{m}_2)} \sin \alpha + \left(s_2 \chi_q^{(m_2', \bar{m}_2)} \right)^2}{\ell} \right]^{\frac{1}{2}}; \nu, M \right) \sqrt{\frac{1-\xi_0}{\xi_0}} d\xi_0 \\
 &\dots\dots (3-64)
 \end{aligned}$$

and

$$\begin{aligned}
 & Q_r^{(n)} \left(\bar{\xi}_p^{(n_2')}, \chi_q^{(m_2', \bar{m}_2)}, \eta_0; \nu, M \right) \\
 &= \frac{1}{\ell^4} \left[s_1^2 \eta_0^2 + 2s_1 s_2 \eta_0 \chi_q^{(m_2', \bar{m}_2)} \sin \alpha + \left(s_2 \chi_q^{(m_2', \bar{m}_2)} \right)^2 \right]^2 \\
 &\quad \times \int_0^1 h_r^{(n)}(\xi_0) F \left(\frac{\bar{x}_{p,q}^{(n_2', m_2', \bar{m}_2)} - x_0}{\ell} \right), \\
 &\quad \left[\frac{s_1^2 \eta_0^2 + 2s_1 s_2 \eta_0 \chi_q^{(m_2', \bar{m}_2)} \sin \alpha + \left(s_2 \chi_q^{(m_2', \bar{m}_2)} \right)^2}{\ell} \right]^{\frac{1}{2}}; \nu, M \right) \sqrt{\frac{1-\xi_0}{\xi_0}} d\xi_0. \\
 &\dots\dots (3-65)
 \end{aligned}$$

Let us now write

$$\begin{aligned}
 & g_s^{(m_1)}(\eta_0) P_r^{(n)}\left(\bar{\xi}_p^{(n_2')}, \chi_q^{(m_2', \bar{m}_2)}, \eta_0; \nu, M\right) \\
 &= \sum_{\ell=1}^{\bar{m}_1} g_s^{(m_1)}(\zeta_\ell^{(\bar{m}_1)}) P_r^{(n)}\left(\bar{\xi}_p^{(n_2')}, \chi_q^{(m_2', \bar{m}_2)}, \zeta_\ell^{(\bar{m}_1)}; \nu, M\right) \bar{g}_\ell^{(\bar{m}_1)}(\eta_0) \quad (3-66)
 \end{aligned}$$

and

$$\begin{aligned}
 & g_s^{(m_1)}(\eta_0) Q_r^{(n)}\left(\bar{\xi}_p^{(n_2')}, \chi_q^{(m_2', \bar{m}_2)}, \eta_0; \nu, M\right) \\
 &= \sum_{\ell=1}^{\bar{m}_1} g_s^{(m_1)}(\zeta_\ell^{(\bar{m}_1)}) Q_r^{(n)}\left(\bar{\xi}_p^{(n_2')}, \chi_q^{(m_2', \bar{m}_2)}, \zeta_\ell^{(\bar{m}_1)}; \nu, M\right) \bar{g}_\ell^{(\bar{m}_1)}(\eta_0) \quad (3-67)
 \end{aligned}$$

On substituting for $g_s^{(m_1)}(\eta_0) P_r^{(n)}\left(\bar{\xi}_p^{(n_2')}, \chi_q^{(m_2', \bar{m}_2)}, \eta_0; \nu, M\right)$ and $g_s^{(m_1)}(\eta_0) Q_r^{(n)}\left(\bar{\xi}_p^{(n_2')}, \chi_q^{(m_2', \bar{m}_2)}, \eta_0; \nu, M\right)$ from (3-66) and (3-67) respectively into the right-hand side of formula (3-63) we get

$$\begin{aligned}
 & w_{r,s}^{(2,1)}\left(\bar{x}_{p,q}^{(n_2', m_2', \bar{m}_2)}, u_q^{(m_2', \bar{m}_2)}; \nu, M\right) \\
 &= -s_1 \ell \sin \alpha \sum_{\ell=1}^{\bar{m}_1} g_s^{(m_1)}(\zeta_\ell^{(\bar{m}_1)}) P_r^{(n)}\left(\bar{\xi}_p^{(n_2')}, \chi_q^{(m_2', \bar{m}_2)}, \zeta_\ell^{(\bar{m}_1)}; \nu, M\right) \\
 &\quad \times \int_0^1 \frac{\bar{g}_\ell^{(\bar{m}_1)}(\eta_0) \sqrt{1-\eta_0} d\eta_0}{\left[s_1^2 \eta_0^2 + 2s_1 s_2 \eta_0 \chi_q^{(m_2', \bar{m}_2)} \sin \alpha + \left(s_2 \chi_q^{(m_2', \bar{m}_2)} \right)^2 \right]} \\
 &= -s_1 \ell (\cos \alpha)^2 \sum_{\ell=1}^{\bar{m}_1} g_s^{(m_1)}(\zeta_\ell^{(\bar{m}_1)}) Q_r^{(n)}\left(\bar{\xi}_p^{(n_2')}, \chi_q^{(m_2', \bar{m}_2)}, \zeta_\ell^{(\bar{m}_1)}; \nu, M\right) \\
 &\quad \times \int_0^1 \frac{s_1 s_2 \eta_0 \chi_q^{(m_2', \bar{m}_2)} \bar{g}_\ell^{(\bar{m}_1)}(\eta_0) \sqrt{1-\eta_0} d\eta_0}{\left[s_1^2 \eta_0^2 + 2s_1 s_2 \eta_0 \chi_q^{(m_2', \bar{m}_2)} \sin \alpha + \left(s_2 \chi_q^{(m_2', \bar{m}_2)} \right)^2 \right]^2} \quad \dots \dots (3-68)
 \end{aligned}$$

We use the formula (3-68) for $w_{r,s}^{(2,1)}\left(\bar{x}_{p,q}^{(n_2', m_2', \bar{m}_2)}, u_q^{(m_2', \bar{m}_2)}; \nu, M\right)$ to get $\psi_{i,j;r,s}^{(2,1)}$ from formula (3-61). To use formula (3-68) we need to evaluate the quantities

$$P_r^{(n)}\left(\bar{\xi}_p^{(n_2')}, \chi_q^{(m_2', \bar{m}_2)}, \zeta_\ell^{(\bar{m}_1)}; \nu, M\right), \quad (3-69)$$

$$Q_r^{(n)}\left(\bar{\xi}_p^{(n_2')}, \chi_q^{(m_2', \bar{m}_2)}, \zeta_\ell^{(\bar{m}_1)}; \nu, M\right), \quad (3-70)$$

$$\ell^2 \int_0^1 \frac{\bar{g}_\ell^{(\bar{m}_1)}(\eta_0) \sqrt{1 - \eta_0} d\eta_0}{\left[s_1^2 \eta_0^2 + 2s_1 s_2 \eta_0 \chi_q^{(m_2', \bar{m}_2)} \sin \alpha + \left(s_2 \chi_q^{(m_2', \bar{m}_2)} \right)^2 \right]} \quad (3-71)$$

and

$$\ell^2 \int_0^1 \frac{s_1 s_2 \eta_0 \chi_q^{(m_2', \bar{m}_2)} \bar{g}_\ell^{(\bar{m}_1)}(\eta_0) \sqrt{1 - \eta_0} d\eta_0}{\left[s_1^2 \eta_0^2 + 2s_1 s_2 \eta_0 \chi_q^{(m_2', \bar{m}_2)} \sin \alpha + \left(s_2 \chi_q^{(m_2', \bar{m}_2)} \right)^2 \right]^2}. \quad (3-72)$$

The quantities (3-69) and (3-70) are obtained from formulae (3-64) and (3-65) respectively by using numerical integration in ξ_0 and the quantities (3-71) and (3-72) are evaluated by using numerical integration in η_0 .

We now use the expression (2-21) for the kernel function $K_2(x, u, \nu, \theta; \nu, M)$ in formula (2-74) to get

$$\begin{aligned} & w_{r,s}^{(2,3)}\left(\bar{x}_{p,q}^{(n_2', m_2', \bar{m}_2)}, u_q^{(m_2', \bar{m}_2)}; \nu, M\right) \\ &= -\frac{\ell}{s_2} \cos 2\alpha \int_0^1 g_s^{(m_2)}(\eta_0) S_r^{(n)}\left(\bar{\xi}_p^{(n_2')}, \chi_q^{(m_2', \bar{m}_2)}, \eta_0; \nu, M\right) \\ & \quad \times \frac{\sqrt{1 - \eta_0} d\eta_0}{\left[\eta_0^2 + 2\eta_0 \chi_q^{(m_2', \bar{m}_2)} \cos 2\alpha + \left(\chi_q^{(m_2', \bar{m}_2)} \right)^2 \right]} \\ & - \frac{\ell}{s_2} (\sin 2\alpha)^2 \int_0^1 g_s^{(m_2)}(\eta_0) T_r^{(n)}\left(\bar{\xi}_p^{(n_2')}, \chi_q^{(m_2', \bar{m}_2)}, \eta_0; \nu, M\right) \\ & \quad \times \frac{\eta_0 \chi_q^{(m_2', \bar{m}_2)} \sqrt{1 - \eta_0} d\eta_0}{\left[\eta_0^2 + 2\eta_0 \chi_q^{(m_2', \bar{m}_2)} \cos 2\alpha + \left(\chi_q^{(m_2', \bar{m}_2)} \right)^2 \right]^2} \end{aligned} \quad (3-73)$$

where

$$\begin{aligned}
 & S_r^{(n)}\left(\bar{\xi}_p^{(n_2')}, \chi_q^{(m_2', \bar{m}_2)}, \eta_0; \nu, M\right) \\
 &= \frac{s_2^2}{\ell^2} \left[\eta_0^2 + 2\eta_0 \chi_q^{(m_2', \bar{m}_2)} \cos 2\alpha + \left(\chi_q^{(m_2', \bar{m}_2)}\right)^2 \right] \\
 & \times \int_0^1 h_r^{(n)}(\xi_0) K_1 \left(\frac{\bar{x}_{p,q}^{(n_2', m_2', \bar{m}_2)} - x_0}{\ell} ; \nu, M \right) \sqrt{\frac{1-\xi_0}{\xi_0}} d\xi_0 \\
 & \dots\dots (3-74)
 \end{aligned}$$

and

$$\begin{aligned}
 & T_r^{(n)}\left(\bar{\xi}_p^{(n_2')}, \chi_q^{(m_2', \bar{m}_2)}, \eta_0; \nu, M\right) \\
 &= \frac{s_4^4}{\ell^4} \left[\eta_0^2 + 2\eta_0 \chi_q^{(m_2', \bar{m}_2)} \cos 2\alpha + \left(\chi_q^{(m_2', \bar{m}_2)}\right)^2 \right] \\
 & \times \int_0^1 h_r^{(n)}(\xi_0) F \left(\frac{\bar{x}_{p,q}^{(n_2', m_2', \bar{m}_2)} - x_0}{\ell} ; \nu, M \right) \sqrt{\frac{1-\xi_0}{\xi_0}} d\xi_0 \\
 & \dots\dots (3-75)
 \end{aligned}$$

Let us now write

$$\begin{aligned}
 & g_s^{(m_2)}(\eta_0) S_r^{(n)}\left(\bar{\xi}_p^{(n_2')}, \chi_q^{(m_2', \bar{m}_2)}, \eta_0; \nu, M\right) \\
 &= \sum_{\ell=1}^{\bar{m}_2} g_s^{(m_2)}\left(\zeta_\ell^{(\bar{m}_2)}\right) S_r^{(n)}\left(\bar{\xi}_p^{(n_2')}, \chi_q^{(m_2', \bar{m}_2)}, \zeta_\ell^{(\bar{m}_2)}; \nu, M\right) \bar{g}_\ell^{(\bar{m}_2)}(\eta_0) \quad (3-76)
 \end{aligned}$$

and

$$\begin{aligned}
 & g_s^{(m_2)}(\eta_0) T_r^{(n)} \left(\bar{\xi}_p^{(n_2')}, \chi_q^{(m_2', \bar{m}_2)}, \eta_0; \nu, M \right) \\
 &= \sum_{\ell=1}^{\bar{m}_2} g_s^{(m_2)} \left(\zeta_\ell^{(\bar{m}_2)} \right) T_r^{(n)} \left(\bar{\xi}_p^{(n_2')}, \chi_q^{(m_2', \bar{m}_2)}, \zeta_\ell^{(\bar{m}_2)}; \nu, M \right) \bar{g}_\ell^{(\bar{m}_2)}(\eta_0). \quad (3-77)
 \end{aligned}$$

On substituting for $g_s^{(m_2)}(\eta_0) S_r^{(n)} \left(\bar{\xi}_p^{(n_2')}, \chi_q^{(m_2', \bar{m}_2)}, \eta_0; \nu, M \right)$ and $g_s^{(m_2)}(\eta_0) T_r^{(n)} \left(\bar{\xi}_p^{(n_2')}, \chi_q^{(m_2', \bar{m}_2)}, \eta_0; \nu, M \right)$ from (3-76) and (3-77) respectively into the right-hand side of formula (3-73) we get

$$\begin{aligned}
 & w_{r,s}^{(2,3)} \left(\bar{x}_{p,q}^{(n_2', m_2', \bar{m}_2)}, u_q^{(m_2', \bar{m}_2)}; \nu, M \right) \\
 &= -\frac{\ell}{s_2} \cos 2\alpha \sum_{\ell=1}^{\bar{m}_2} g_s^{(m_2)} \left(\zeta_\ell^{(\bar{m}_2)} \right) S_r^{(n)} \left(\bar{\xi}_p^{(n_2')}, \chi_q^{(m_2', \bar{m}_2)}, \zeta_\ell^{(\bar{m}_2)}; \nu, M \right) \\
 &\quad \times \int_0^1 \frac{\bar{g}_\ell^{(\bar{m}_2)}(\eta_0) \sqrt{1-\eta_0} d\eta_0}{\left[\eta_0^2 + 2\eta_0 \chi_q^{(m_2', \bar{m}_2)} \cos 2\alpha + \left(\chi_q^{(m_2', \bar{m}_2)} \right)^2 \right]} \\
 &= -\frac{\ell}{s_2} (\sin 2\alpha)^2 \sum_{\ell=1}^{\bar{m}_2} g_s^{(m_2)} \left(\zeta_\ell^{(\bar{m}_2)} \right) T_r^{(n)} \left(\bar{\xi}_p^{(n_2')}, \chi_q^{(m_2', \bar{m}_2)}, \zeta_\ell^{(\bar{m}_2)}; \nu, M \right) \\
 &\quad \times \int_0^1 \frac{\eta_0 \chi_q^{(m_2', \bar{m}_2)} \bar{g}_\ell^{(\bar{m}_2)}(\eta_0) \sqrt{1-\eta_0} d\eta_0}{\left[\eta_0^2 + 2\eta_0 \chi_q^{(m_2', \bar{m}_2)} \cos 2\alpha + \left(\chi_q^{(m_2', \bar{m}_2)} \right)^2 \right]^2}. \quad (3-78)
 \end{aligned}$$

We use the formula (3-78) for $w_{r,s}^{(2,3)} \left(\bar{x}_{p,q}^{(n_2', m_2', \bar{m}_2)}, u_q^{(m_2', \bar{m}_2)}; \nu, M \right)$ to get $\psi_{i,j;r,s}^{(2,3)}$ from formula (3-62). To use formula (3-62) we need to evaluate the quantities

$$S_r^{(n)} \left(\bar{\xi}_p^{(n_2')}, \chi_q^{(m_2', \bar{m}_2)}, \zeta_\ell^{(\bar{m}_2)}; \nu, M \right), \quad (3-79)$$

$$T_r^{(n)} \left(\bar{\xi}_p^{(n_2')}, \chi_q^{(m_2', \bar{m}_2)}, \zeta_\ell^{(\bar{m}_2)}; \nu, M \right), \quad (3-80)$$

$$\frac{\ell^2}{s_2} \int_0^1 \frac{\bar{g}_\ell^{(\bar{m}_2)}(\eta_0) \sqrt{1 - \eta_0} d\eta_0}{\left[\eta_0^2 + 2\eta_0 \chi_q^{(m_2', \bar{m}_2)} \cos 2\alpha + \left(\chi_q^{(m_2', \bar{m}_2)} \right)^2 \right]} \quad (3-81)$$

and

$$\frac{\ell^2}{s_2} \int_0^1 \frac{\eta_0 \chi_q^{(m_2', \bar{m}_2)} \bar{g}_\ell^{(\bar{m}_2)}(\eta_0) \sqrt{1 - \eta_0} d\eta_0}{\left[\eta_0^2 + 2\eta_0 \chi_q^{(m_2', \bar{m}_2)} \cos 2\alpha + \left(\chi_q^{(m_2', \bar{m}_2)} \right)^2 \right]^2} \quad (3-82)$$

The quantities (3-79) and (3-80) are obtained from formulae (3-74) and (3-75) respectively by using numerical integration in ξ_0 and the quantities (3-81) and (3-82) are evaluated by using numerical integration in η_0 .

4 EXAMPLES

We give, in this section, a selection of results of calculations carried out on a number of fin-tailplane configurations. The approximations \hat{Q}_{jk} to the generalised airforce coefficients $Q_{jk}(\nu, M)$ were obtained from the matrix formula (2-169) using a FORTRAN program constructed for this purpose.

The fin-tailplane configurations considered are two with rectangular fin and half-tailplanes and four with swept-back fin and half-tailplanes. The configurations with rectangular surfaces and the first of the configurations with swept-back surfaces are used to get results for comparison with the author's previous results. The second of the configurations with swept-back surfaces is used to get results for comparison with results obtained by several other authors. The remaining configurations are used to get results which show dependence on dihedral angle α and frequency parameter ν , and for one of them a systematic study is made with varying numbers of chordwise and spanwise loading functions.

4.1 Rectangular half-tailplanes of aspect ratio 1 and rectangular fin of aspect ratio 1. Zero dihedral angle α

The planforms of the half-tailplanes and fin are square with

$$s_1 = s_2 = c \quad (4-1)$$

where c is the chord length of both half-tailplanes and of the fin. The two half-tailplanes are set in the same plane so that $\alpha = 0$. The typical length l of the fin-tailplane configuration is taken equal to c .

Six modes of oscillation are considered. These are specified by giving the functions $f_q^{(1)}(x,z)$, $f_q^{(2)}(x,u)$, introduced in formulae (2-1) and (2-2), for $q = 1(1)6$. These functions are taken, in this example, to be

$$f_1^{(1)}(x,z) = 1, \quad f_1^{(2)}(x,u) = 0 \quad (4-2)$$

$$f_2^{(1)}(x,z) = \frac{x}{l}, \quad f_2^{(2)}(x,u) = 0 \quad (4-3)$$

$$f_3^{(1)}(x,z) = \frac{(s_1 - z)}{l}, \quad f_3^{(2)}(x,u) = -\frac{u}{l} \quad (4-4)$$

$$f_4^{(1)}(x,z) = \frac{x(s_1 - z)}{l^2}, \quad f_4^{(2)}(x,u) = -\frac{xu}{l^2} \quad (4-5)$$

$$f_5^{(1)}(x,z) = \frac{(s_1 - z)^2}{l^2}, \quad f_5^{(2)}(x,u) = -\frac{2s_1 u}{l^2} \quad (4-6)$$

$$f_6^{(1)}(x,z) = \frac{x(s_1 - z)^2}{l^3}, \quad f_6^{(2)}(x,u) = -\frac{s_1 xu}{l^3} \quad (4-7)$$

where the origin of coordinates is taken at the leading point of the junction chord of the fin and half-tailplanes.

Approximations \hat{Q}_{ij} , $i = 1(1)6$, $j = 1(1)6$, to the generalised airforce coefficients $Q_{ij}(v,M)$ for

$$v = 0.3 \quad \text{and} \quad M_\infty = 0.866$$

have been evaluated by taking $m_1 = 4$, $m_2 = 4$, $n = 3$, $m_1' = 4$, $m_2' = 4$, $n_1' = 3$, $n_2' = 3$, $a_1 = 1$ and $a_2 = 1$.

We write \hat{Q}_{ij} in the form

$$\hat{Q}_{ij} = \hat{Q}_{ij}' + iv\hat{Q}_{ij}'' \quad (4-8)$$

where \hat{Q}_{ij}' and \hat{Q}_{ij}'' are real quantities.

This example is chosen to be exactly the same as example 1 of Ref 1, so that we may compare results. We must notice, however, that \hat{Q}_{ij}'' of this Report is to be compared with Q_{ij}''/ν of Ref 1. The numerical values of \hat{Q}_{ij} , $i = 1(1)6$, $j = 1(1)6$, obtained using the present method are given in Table 1 immediately above the corresponding numerical values from Ref 1 with $m = 4$, $n = 3$, which are in brackets. We observe that the two sets of values are in good agreement.

4.2 Rectangular half-tailplanes of aspect ratio $\frac{1}{2}$ and rectangular fin of aspect ratio 1. Zero dihedral angle α

The planforms of the half-tailplanes and fin are rectangles with

$$s_1 = c, \quad s_2 = \frac{1}{2}c \quad (4-9)$$

where c is the chord length of both half-tailplanes and of the fin. Again the two half-tailplanes are coplanar and the typical length ℓ of the fin-tailplane configuration is taken equal to c .

Four modes of oscillation are considered by specifying the functions $f_q^{(1)}(x,z)$, $f_q^{(2)}(x,u)$, $q = 1(1)4$ to be

$$f_1^{(1)}(x,z) = 1, \quad f_1^{(2)}(x,u) = 0 \quad (4-10)$$

$$f_2^{(1)}(x,z) = \frac{(x - \frac{1}{2}\ell)}{\ell}, \quad f_2^{(2)}(x,u) = 0 \quad (4-11)$$

$$f_3^{(1)}(x,z) = \frac{(\frac{3}{2}s_1 - z)}{\ell}, \quad f_3^{(2)}(x,u) = -\frac{u}{\ell} \quad (4-12)$$

$$f_4^{(1)}(x,z) = 0, \quad f_4^{(2)}(x,u) = -\frac{u}{\ell} \quad (4-13)$$

where the origin of coordinates is again taken at the leading point of the junction chord.

Approximations \hat{Q}_{ij} , $i = 1(1)4$, $j = 1(1)4$, to the generalised airforce coefficients for $\nu = 0, 0.1, 0.2, 0.5, 0.7, 1.0$ and for $M = 0$ have been evaluated by taking $m_1 = 4$, $m_2 = 4$, $n = 3$, $m_1' = 4$, $m_2' = 4$, $n_1' = 3$, $n_2' = 3$, $a_1 = 1$ and $a_2 = 1$. To avoid a numerical breakdown the value $\nu = 0$ is replaced by a small value $\nu = 0.000001$.

This example is exactly the same as Example 2 of Ref 1, but only \hat{Q}_{i2} , $i = 1(1)4$, may be compared because these are the only quantities available in Ref 1. We must notice, however, that \hat{Q}_{i2}'' of this Report is to be compared with Q_{i2}''/ν of Ref 1 and that this latter quantity cannot be obtained from Ref 1 when $\nu = 0$.

The numerical values of \hat{Q}_{i2} , $i = 1(1)4$, obtained by using the present method are given in Table 2 immediately above the corresponding numerical values in brackets from Ref 1 with $m = 4$, $n = 3$. We observe that the two sets of values are in good agreement over the range of frequency parameter considered.

4.3 Swept-back half-tailplanes and swept-back fin. Zero dihedral angle α

In this example the planforms of the fin and a half-tailplane are as given in Fig 3 and in Example 3 of Ref 1. The two half-tailplanes are set in the same plane so that $\alpha = 0$. The typical length ℓ of the fin-tailplane configuration is taken equal to the length DC of the junction chord and the leading point D is taken to be the origin of coordinates.

Six modes of oscillation are considered by specifying the functions $f_q^{(1)}(x,z)$, $f_q^{(2)}(x,u)$, $q = 1(1)6$ of formulae (2-1) and (2-2) to be

$$f_1^{(1)}(x,z) = 1, \quad f_1^{(2)}(x,u) = 0 \quad (4-14)$$

$$f_2^{(1)}(x,z) = \frac{x}{\ell}, \quad f_2^{(2)}(x,u) = 0 \quad (4-15)$$

$$f_3^{(1)}(x,z) = \frac{(s_1 - z)}{\ell}, \quad f_3^{(2)}(x,u) = -\frac{u}{\ell} \quad (4-16)$$

$$f_4^{(1)}(x,z) = \frac{x(s_1 - z)}{\ell^2}, \quad f_4^{(2)}(x,u) = 0 \quad (4-17)$$

$$f_5^{(1)}(x,z) = \frac{(s_1 - z)^2}{\ell^2}, \quad f_5^{(2)}(x,u) = -\frac{2s_1 u}{\ell^2} \quad (4-18)$$

$$f_6^{(1)}(x,z) = 0, \quad f_6^{(2)}(x,u) = -\frac{u}{\ell} \quad (4-19)$$

Approximations \hat{Q}_{ij} , $i = 1(1)6$, $j = 1(1)6$, to the generalised airforce coefficients for

$$v = 0.5 \quad \text{and} \quad M = 0.866$$

have been evaluated by using the present method and taking

- (i) $m_1 = m_2 = 4$, $n = 3$, $m'_1 = m'_2 = 4$, $n'_1 = n'_2 = 3$, $a_1 = a_2 = 1$,
- (ii) $m_1 = m_2 = 6$, $n = 3$, $m'_1 = m'_2 = 6$, $n'_1 = n'_2 = 3$, $a_1 = a_2 = 1$,
- (iii) $m_1 = m_2 = 9$, $n = 3$, $m'_1 = m'_2 = 9$, $n'_1 = n'_2 = 3$, $a_1 = a_2 = 1$,
- (iv) $m_1 = m_2 = 12$, $n = 3$, $m'_1 = m'_2 = 12$, $n'_1 = n'_2 = 3$, $a_1 = a_2 = 1$,
- (v) $m_1 = m_2 = 15$, $n = 3$, $m'_1 = m'_2 = 15$, $n'_1 = n'_2 = 3$, $a_1 = a_2 = 1$.

These numerical values of \hat{Q}_{ij} are given in Table 3 together with the corresponding numerical values in brackets from Example 3 of Ref 1 with $m = 4$, $n = 3$. One can see from Table 3 that the \hat{Q}'_{ij} and \hat{Q}''_{ij} , $i = 1(1)6$, $j = 1(1)6$, seem each to be converging as m_1 and m_2 are increased from 4 to 15, but some of these, eg \hat{Q}''_{23} , change quite rapidly with increase of m_1 and m_2 at low values of m_1 and m_2 . The corresponding values of \hat{Q}_{ij} from Ref 1 are seen not to be all in good agreement with the present values. The values of \hat{Q}_{11} , \hat{Q}_{55} , \hat{Q}_{56} , \hat{Q}_{65} and \hat{Q}_{66} , for example, are in moderately good agreement, whereas the values of \hat{Q}_{25} , \hat{Q}_{26} , \hat{Q}_{43} , \hat{Q}_{45} and \hat{Q}_{46} , for example, are in poor agreement.

4.4 The Stark fin-tailplane configuration

The fin-tailplane configuration introduced by Stark in Ref 4 and further considered by him in Ref 8 has been used as an example by several workers including the present author with the method of Ref 1. The configuration taken by Stark in Ref 8 is exactly the same as that taken by Böhm and Schmid in Ref 6 and differs slightly from Stark's original configuration in Ref 4. The chords of the fin and half-tailplanes at their junction are not of equal length so we modify the Böhm and Schmid fin⁶ to make these chords of equal length and coincident. The Böhm and Schmid fin planform is the planform ABC'D in Fig 4 and the modified planform is ABTCD. The Böhm and Schmid tailplane is not modified and is the planform CDEF in Fig 4.

The two half-tailplanes are coplanar. The typical length l of the configuration is taken equal to the span of the fin, which is also equal to the span of each half-tailplane, and without loss of generality we take $l = 1$. The origin of coordinates is taken to be the leading point D of the junction chord.

The x coordinate of the leading edge $e_1(z)$ and the chord length $c_1(z)$ of the modified fin at spanwise position z are given by the formulae

$$e_1(z) = -0.79z \quad 0 \leq z \leq 1.0, \quad (4-20)$$

$$c_1(z) = \begin{cases} 0.82 + 0.47z - 0.118(125z^3 - 75z^2 + 15z - 1) & 0 \leq z \leq 0.2, \\ 0.82 + 0.47z & 0.2 \leq z \leq 1.0. \end{cases} \quad (4-21)$$

The leading edge has not been modified at all but the chord length has been modified in the region $0 \leq z \leq 0.2$, the function $c_1(z)$ being so chosen that $c_1''(z)$ is continuous throughout the interval $(0,1)$ of z and so that $c_1(0) = c_2(0)$, where $c_2(y)$ is defined below. There is a requirement that $c_1''(z)$ should exist because it occurs in formula (B-73) for

$$\left[\left(\frac{\partial^2}{\partial \eta_0^2} \right) \left\{ I_r^{(n)*}(\xi, \eta, \eta_0, \nu, M) \right\} \right]_{\eta_0 = \eta}.$$

The x coordinate of the leading edge $e_2(y)$ and the chord length $c_2(y)$ of a half-tailplane at spanwise position y are given by the formulae

$$e_2(y) = 0.34y \quad 0 \leq y \leq 1.0, \quad (4-22)$$

$$c_2(y) = 0.938 - 0.463y \quad 0 \leq y \leq 1.0. \quad (4-23)$$

Three modes of oscillation are considered by specifying the functions $f_q^{(1)}(x,z)$, $f_q^{(2)}(x,u)$, $q = 1(1)3$, to be

$$f_1^{(1)}(x,z) = 3(x + 0.145), \quad f_1^{(2)}(x,u) = 0 \quad (4-24)$$

$$f_2^{(1)}(x,z) = 1, \quad f_2^{(2)}(x,u) = 0 \quad (4-25)$$

$$f_3^{(1)}(x,z) = z, \quad f_3^{(2)}(x,u) = u. \quad (4-26)$$

Approximations \hat{Q}_{ij} , $i = 1(1)3$, $j = 1(1)3$, to the generalised airforce coefficients for

$$\nu = 0.6 \quad \text{and} \quad M_\infty = 0.8$$

have been evaluated by taking

- (i) $m_1 = m_2 = 4, n = 3, m'_1 = m'_2 = 4, n'_1 = n'_2 = 3, a_1 = a_2 = 1,$
- (ii) $m_1 = m_2 = 6, n = 3, m'_1 = m'_2 = 6, n'_1 = n'_2 = 3, a_1 = a_2 = 1,$
- (iii) $m_1 = m_2 = 9, n = 3, m'_1 = m'_2 = 9, n'_1 = n'_2 = 3, a_1 = a_2 = 1,$
- (iv) $m_1 = m_2 = 12, n = 3, m'_1 = m'_2 = 12, n'_1 = n'_2 = 3, a_1 = a_2 = 1,$
- (v) $m_1 = m_2 = 6, n = 4, m'_1 = m'_2 = 6, n'_1 = n'_2 = 4, a_1 = a_2 = 1,$
- (vi) $m_1 = m_2 = 9, n = 4, m'_1 = m'_2 = 9, n'_1 = n'_2 = 4, a_1 = a_2 = 1,$
- (vii) $m_1 = m_2 = 12, n = 4, m'_1 = m'_2 = 12, n'_1 = n'_2 = 4, a_1 = a_2 = 1.$

From their numerical values in Table 4 we can see that the \hat{Q}'_{ij} and \hat{Q}''_{ij} , $i = 1(1)3, j = 1(1)3$, seem to be converging as m_1 and m_2 are increased for fixed value of n . Not enough values have been obtained to determine how the convergence with increasing n proceeds, but it is apparent that changing n from 3 to 4 does not affect results very much.

Values of $(1/2\pi)\hat{Q}'_{ij}$ and $(v/2\pi)\hat{Q}''_{ij}$, $i = 1(1)3, j = 1(1)3$, obtained by several workers have been tabulated by Stark in Ref 8. The values from Stark's table together with the values obtained using the present method with case (iv) are given in Table 5. The values obtained by the method of Ref 1 by the present author were obtained with $m = 4, n = 3$. The agreement between all the values presented in Table 5 is good.

4.5 Swept-back half-tailplanes and swept-back fin. General dihedral angle α

For this example the planforms of the fin and half-tailplane are modifications of the AGARD planforms of fin and half-tailplane⁶. These modified planforms are given in Fig 5 and are such that there is a common junction chord. The typical length l is taken equal to s_2 , the span of the half-tailplane. The origin of coordinates is forward of the configuration on the line of the junction chord.

Six modes of oscillation are considered. These are specified by giving the functions $f_q^{(1)}(x,z), f_q^{(2)}(x,u)$, introduced in formulae (2-1) and (2-2), for $q = 1(1)6$. These functions are taken, in this example, to be

$$f_1^{(1)}(x,z) = (1.2 - z)^2, \quad f_1^{(2)}(x,u) = -1.44 \sin \alpha \quad (4-27)$$

$$f_2^{(1)}(x,z) = (1.2 - z)(x + 0.875z - 4.05), \quad f_2^{(2)}(x,u) = -1.2(x - 4.05) \sin \alpha$$

..... (4-28)

$$f_3^{(1)}(x,z) = 0.0, \quad f_3^{(2)}(x,u) = u \quad (4-29)$$

$$f_4^{(1)}(x,z) = 1.0, \quad f_4^{(2)}(x,u) = -\sin \alpha \quad (4-30)$$

$$f_5^{(1)}(x,z) = (x - 3.70), \quad f_5^{(2)}(x,u) = -(x - 3.70) \sin \alpha$$

..... (4-31)

$$f_6^{(1)}(x,z) = (1.2 - z), \quad f_6^{(2)}(x,u) = -(u + 1.2 \sin \alpha)$$

..... (4-32)

The first two modes are flexible modes, the third mode is rolling of the tailplanes without any movement of the fin, the fourth mode is sideways translation of the whole configuration, the fifth mode is yawing of the whole configuration about the axis $x = 3.70$, $y = 0.0$ through D and the sixth mode is rolling of the whole configuration about the axis $y = 0.0$, $z = 1.2$ (AB in Fig 5).

In Tables 6 and 7 are presented the values of the approximations \hat{Q}_{ij} , $i = 1(1)6$, $j = 1(1)6$, to the generalised airforce coefficients $Q_{ij}(\nu, M)$ which have been evaluated for the set of values

$$-\frac{\pi}{6}, \quad -\frac{\pi}{12}, \quad 0, \quad \frac{\pi}{12}, \quad \frac{\pi}{6}$$

of the dihedral angle α by taking

$$m_1 = m'_1 = m_2 = m'_2 = 8, \quad n = n'_1 = n'_2 = 5, \quad a_1 = a_2 = 1,$$

for the two respective pairs

$$\nu = 0.000001, \quad M = 0.8$$

and

$$\nu = 1.5, \quad M = 0.8$$

of frequency parameter and Mach number.

We see, from these two tables, that there is a marked change in most of the generalised airforce coefficients with change of α at the two values of frequency parameter.

In Table 8 are presented the values of the approximations \hat{Q}_{ij} , $i = 1(1)6$, $j = 1(1)6$, for $\alpha = 0$, $M = 0.8$ and the set of values

$$0.0000001, \quad 0.25, \quad 0.50, \quad 0.75, \quad 1.00, \quad 1.25, \quad 1.50$$

of frequency parameter ν , which have been evaluated by taking

$$m_1 = m'_1 = m_2 = m'_2 = 8, \quad n = n'_1 = n'_2 = 5, \quad a_1 = a_2 = 1.$$

In brackets in Table 8 are presented the corresponding values of \hat{Q}_{ij} , $i = 1(1)3$, $j = 1(1)3$, obtained by Nayler and Doe¹⁰ for the set of values

$$0.001, \quad 0.75, \quad 1.25, \quad 1.50$$

of ν by using their doublet lattice method with 12 locations chordwise and 8 spanwise on each surface. The agreement of the two sets of results is good for practical purposes, the agreement being a trifle better at the lower values of the frequency parameter ν than at the higher values.

In Table 9 are presented the values of the approximations \hat{Q}_{ij} , $i = 1(1)3$, $j = 1(1)3$, to the generalised airforce coefficients $Q_{ij}(\nu, M)$ for

$$\nu = 1.5, \quad M = 0.8 \quad \text{and} \quad \alpha = 0$$

which have been evaluated by taking

$$m_1 = m'_1 = m_2 = m'_2, \quad n = n'_1 = n'_2, \quad a_1 = a_2 = 1$$

for a number of combinations of m_1 and n in the ranges $3 \leq m_1 \leq 10$, $3 \leq n \leq 8$. From this table the nature of the convergence of the quantities \hat{Q}_{ij} with increase in the values of m_1 and n may be observed.

Most of the quantities \hat{Q}'_{ij} and \hat{Q}''_{ij} , $i = 1(1)3$, $j = 1(1)3$ seem to be converging as m_1 and n are increased even though the convergence is not as rapid as it is for isolated wing generalised airforce coefficients. However, the convergence of \hat{Q}'_{22} on its own appears to be quite poor, but the quantity

\hat{Q}'_{22} must be viewed in conjunction with the quantity \hat{Q}''_{22} , which is numerically much larger than \hat{Q}'_{22} , and the convergence of \hat{Q}''_{22} is relatively good. It may be noted that \hat{Q}'_{22} changes sign for a small negative value of the dihedral angle α , as can be seen from Table 7, and possibly this may account for the relatively large proportional changes in \hat{Q}'_{22} , when m_1 and n are changed, in comparison with the converged value.

In Table 10 are presented the values of the approximations \hat{Q}_{ij} , $i = 1(1)3$, $j = 1(1)3$, to the generalised airforce coefficients $Q_{ij}(\nu, M)$ for

$$\nu = 1.5, \quad M = 0.8 \quad \text{and} \quad \alpha = 0$$

which have been evaluated by taking

$$m_1 = m'_1 = m_2 = m'_2, \quad n = n'_1 = n'_2 = 3, \quad a_1 = a_2 = a$$

for a number of combinations of m_1 and a in the ranges $4 \leq m_1 \leq 8$, $1 \leq a \leq 4$. From this table the nature of the convergence of the quantities \hat{Q}_{ij} with increase in the value of m_1 for a given value of a may be observed. From the numbers presented in Table 10 it is difficult to say whether or not the convergence is the more rapid the higher the value of a .

In Table 11 are presented the values of the approximations \hat{Q}_{ij} , $i = 1(1)3$, $j = 1(1)3$, to the generalised airforce coefficients $Q_{ij}(\nu, M)$ for

$$\nu = 1.5, \quad M_\infty = 0.8 \quad \text{and} \quad \alpha = 0$$

which have been evaluated by taking

$$m_1 = m'_1, \quad m_2 = m'_2, \quad n = n'_1 = n'_2 = 3, \quad a_1 = a_2 = 1$$

for a number of combinations of m_1 and m_2 in the ranges $3 \leq m_1 \leq 6$, $3 \leq m_2 \leq 6$.

For this example, Table 11 shows that increase of m_1 with m_2 fixed has less effect on the quantities \hat{Q}_{ij} than does increase of m_2 with m_1 fixed.

4.6 Second case of swept-back half-tailplanes and swept-back fin. General dihedral angle α

For this example again the planforms of the fin and half-tailplane are modifications of the AGARD planforms of fin and half-tailplane⁶. The whole

configuration corresponds to the AGARD low tailplane case turned upside-down. The modified planforms are given in Fig 6 and are such that there is a common junction chord. The typical length l is taken equal to s_2 , the span of the half-tailplane. The origin of coordinates is forward of the configuration on the line of the junction chord.

Again six modes of oscillation are considered by specifying the functions $f_q^{(1)}(x,z)$, $f_q^{(2)}(x,u)$, $q = 1(1)6$ to be

$$f_1^{(1)}(x,z) = z^2 \quad f_1^{(2)}(x,u) = 0.0 \quad (4-33)$$

$$f_2^{(1)}(x,z) = z(x - 0.875z - 3.0) \quad f_2^{(2)}(x,u) = 0.0 \quad (4-34)$$

$$f_3^{(1)}(x,z) = 0.0 \quad f_3^{(2)}(x,u) = u \quad (4-35)$$

$$f_4^{(1)}(x,z) = 1.0 \quad f_4^{(2)}(x,u) = -\sin \alpha \quad (4-36)$$

$$f_5^{(1)}(x,z) = x - 3.70 \quad f_5^{(2)}(x,u) = -(x - 3.70) \sin \alpha \quad (4-37)$$

$$f_6^{(1)}(x,z) = z \quad f_6^{(2)}(x,u) = u \quad (4-38)$$

These six modes are closely related to the six modes of Example 4.5. The same remarks can be made about the first four modes. The fifth mode is yawing of the whole configuration about the axis $x = 3.70$, $y = 0.0$ through A in Fig 6 and the sixth mode is rolling of the whole configuration about the junction chord $y = 0.0$, $z = 0.0$.

In Table 12 are presented the values of the approximations \hat{Q}_{ij} , $i = 1(1)6$, $j = 1(1)6$ for

$$v = 0.0000001 \quad \text{and} \quad M = 0.8$$

which have been evaluated for the set of values

$$-\frac{\pi}{6}, \quad -\frac{\pi}{12}, \quad 0, \quad \frac{\pi}{12}, \quad \frac{\pi}{6}$$

of the dihedral angle α by taking

$$m_1 = m'_1 = m_2 = m'_2 = 8, \quad n = n'_1 = n'_2 = 5, \quad a_1 = a_2 = 1.$$

When the value of ν of the last case is changed from 0.0000001 to 1.5 without any other change the values \hat{Q}_{ij} presented in Table 13 are obtained. For the special case of zero dihedral angle α and the set of values

$$0.0000001, \quad 0.25, \quad 0.50, \quad 0.75, \quad 1.00, \quad 1.25, \quad 1.50$$

of ν and again without any other change the values \hat{Q}_{ij} presented in Table 14 are obtained. In brackets in Table 14 are presented the corresponding values of \hat{Q}_{ij} , $i = 1(1)3$, $j = 1(1)3$, obtained by Nayler and Doe¹⁰ for the set of values

$$0.001, \quad 0.75, \quad 1.25, \quad 1.50$$

of ν by using their doublet lattice method with 12 locations chordwise and 8 spanwise on each surface. As in Example 4.5 the agreement of the two sets of results is good for practical purposes, the agreement being rather better at the lower values of the frequency parameter ν than at the higher values. In this connection it may be noted that the authors of the doublet lattice method do not recommend its use above $\nu = 1.50$.

5 CONCLUSIONS

A development of the author's previous theory¹ for calculating the subsonic oscillatory airforce coefficients for fin-tailplane configurations has been carried out for arbitrary frequency parameter and Mach number. The results obtained show good convergence of the values of the airforce coefficients when the numbers of terms in the approximations to the loading distributions on the fin and half-tailplane surfaces are increased. However, the incorporation of higher-order integration techniques ($a_1 > 1$, $a_2 > 1$) did not lead to significant improvements and the low-order technique ($a_1 = 1$, $a_2 = 1$) with adequate numbers of terms in the loading distributions is therefore recommended.

Results obtained for the Stark fin-tailplane configuration using the present theory with 3 chordwise and 12 spanwise basic functions in the loading compare well with corresponding results obtained by other workers. Results obtained for other configurations illustrate the effect on the values of the generalised airforce coefficients of setting the half-tailplanes at a number of different dihedral angles.

Appendix A

NUMERICAL INTEGRATION FORMULAE

In this Appendix we show how to evaluate the integration points $\eta_s^{(m)}$, $s = 1(1)m$, and the integration multipliers $G_s^{(m)}$, $s = 1(1)m$, of the numerical integration formula (2-64), the integration points $\zeta_k^{(\bar{m})}$, $k = 1(1)\bar{m}$, and the integration multipliers $\bar{G}_k^{(\bar{m})}$ of the numerical integration formula (3-1), and also the integration points $\chi_j^{(m', \bar{m})}$, $j = 1(1)m'$, and the integration multipliers $G_j^{(m', \bar{m})}$, $j = 1(1)m'$, of the numerical integration formula (3-7).

Let $\gamma_r(p, q, \eta)$, $r = 0, 1, 2, \dots$, in which p and q are constant parameters, be polynomials of degree r in η which satisfy the orthogonality relations

$$\int_0^1 \gamma_r(p, q, \eta) \gamma_s(p, q, \eta) \eta^{q-1} (1-\eta)^{p-q} d\eta = 0 \quad r \neq s. \quad (A-1)$$

The parameters p and q are taken to satisfy the inequalities

$$q > 0, \quad p > q - 1 \quad (A-2)$$

so that the integrals in (A-1) exist.

The polynomial $\gamma_r(p, q, \eta)$ has r zeros in $(0, 1)$ because $\eta^{q-1} (1-\eta)^{p-q}$ is positive in $(0, 1)$. We denote these zeros by $\eta_k(p, q, r)$, $k = 1(1)r$. Then

$$\gamma_r(p, q, \eta_k(p, q, r)) = 0, \quad k = 1(1)r. \quad (A-3)$$

Let the quantities $G_k(p, q, m)$, $k = 1(1)r$, be defined by

$$G_k(p, q, m) = \frac{1}{\left[\frac{d}{d\eta} \gamma_m(p, q, \eta) \right]_{\eta=\eta_k(p, q, m)}} \int_0^1 \frac{\gamma_m(p, q, \eta)}{(\eta - \eta_k(p, q, m))} \eta^{q-1} (1-\eta)^{p-q} d\eta. \quad (A-4)$$

Then we have the Gaussian formula of numerical integration

$$\int_0^1 F(\eta) \eta^{q-1} (1-\eta)^{p-q} d\eta = \sum_{k=1}^m F(\eta_k(p,q,m)) G_k(p,q,m) \quad (A-5)$$

The formula (A-5) is obtained by replacing $F(\eta)$ in the integral on the left by a polynomial of degree $n-1$ in η , which has the values $F(\eta_k(p,q,m))$ at the points $\eta = \eta_k(p,q,m)$, $k = 1(1)m$, and integrating.

The polynomials $\gamma_r(p,q,\eta)$ may be taken to be the Jacobi polynomials (see Ref 14)

$$\begin{aligned} \gamma_r(p,q,\eta) &= \sum_{j=1}^r (-1)^j \frac{\Gamma(r+1)\Gamma(p+r+j)\Gamma(q)}{\Gamma(j+1)\Gamma(r-j+1)\Gamma(p+r)\Gamma(q+j)} \eta^j \\ &= \frac{\Gamma(q)}{\Gamma(q+n)\eta^{q-1}(1-\eta)^{p-q}} \frac{d^r}{d\eta^r} \left[\eta^{r+q-1}(1-\eta)^{r+p-q} \right] \quad (A-6) \end{aligned}$$

They can be shown to satisfy the recurrence relations

$$\begin{aligned} \gamma_r(p,q,\eta) + \left\{ A_r(p,q)\eta + B_r(p,q) \right\} \gamma_{r-1}(p,q,\eta) \\ - \left\{ 1 + B_r(p,q) \right\} \gamma_{r-2}(p,q,\eta) = 0 \quad r \geq 2, \quad (A-7) \end{aligned}$$

and

$$\begin{aligned} n(1-\eta) \frac{d}{d\eta} \gamma_r(p,q,\eta) + r \left\{ \eta - C_r(p,q) \right\} \gamma_r(p,q,\eta) \\ + r C_r(p,q) \gamma_{r-1}(p,q,\eta) = 0 \quad r \geq 0, \quad (A-8) \end{aligned}$$

where
$$A_r(p,q) = \frac{(2r+p-1)(2r+p-2)}{(r+p-1)(r+q-1)}, \quad (A-9)$$

$$B_r(p,q) = \frac{(r-1)(r+q-2)}{(2r+p-3)} A_r(p,q) - \frac{r(2r+p-2)}{(r+p-1)}, \quad (A-10)$$

$$C_r(p,q) = \frac{(r+p-q)}{(2r+p-1)}. \quad (A-11)$$

With the starting values,

$$\gamma_0(p, q, n) = 1 \quad (\text{A-12})$$

$$\gamma_q(p, q, n) = 1 - \frac{(p+1)}{q} n \quad (\text{A-13})$$

we obtain all the functions $\gamma_r(p, q, n)$, $r \geq 2$, from the recurrence relations (A-7). The derivatives $(d/dn)\gamma_r(p, q, n)$, $r \geq 0$, are then obtained from the relation (A-8).

The integration points $\eta_k(p, q, m)$ in formula (A-5) must now be determined as the zeros of $\gamma_m(p, q, n)$ and then the integration multipliers $G_k(p, q, m)$ may be determined from formula (A-4).

We determine a first zero of $\gamma_r(p, q, n)$, $r \geq 1$, straightforwardly by taking any trial value and applying Newton's iterative scheme to get a sequence of values converging to a zero which we take to be $\eta_1(p, q, m)$. We then determine the other zeros by means of the following process. Suppose the k zeros $\eta_j(p, q, m)$, $j = 1(1)k$, have been determined. We form the function $f(n)$ by means of the formula

$$f(n) = \frac{\gamma_m(p, q, n)}{\prod_{j=1}^k (\eta - \eta_j(p, q, m))} \quad (\text{A-14})$$

The function $f(n)$ is a polynomial of degree $(m - k)$ in n and it has the $(m - k)$ zeros $\eta_j(p, q, m)$, $j = k+1(1)m$. We can determine a zero of $f(n)$ by taking any trial value and applying Newton's iterative scheme to get a sequence converging to a zero, which we take to be $\eta_{k+1}(p, q, m)$. Thus if η_a is an approximation to $\eta_{k+1}(p, q, m)$, then the next approximation η_b in the iterative scheme is given by

$$\begin{aligned} \eta_b &= \eta_a - \frac{f(\eta_a)}{f'(\eta_a)} \\ &= \eta_a - \frac{\gamma_m(p, q, \eta_a)}{\left\{ \left[\frac{d}{dn} \gamma_m(p, q, n) \right]_{n=\eta_a} - \gamma_m(p, q, \eta_a) \sum_{j=1}^k \frac{1}{(\eta_a - \eta_j(p, q, m))} \right\}} \quad (\text{A-15}) \end{aligned}$$

All the zeros $\eta_j(p, q, m)$, $j = 1(1)m$, may then be determined, and, if it is desired, reordered.

To determine the integration multipliers $G_k(p, q, m)$ from formula (A-4) we write (A-4) as

$$G_k(p, q, m) = \frac{1}{\left[\frac{d}{dn} \gamma_m(p, q, n) \right]_{n=\eta_k(p, q, m)}} W_m(p, q, \eta_k(p, q, m)) \quad (A-16)$$

$$\text{where } W_r(p, q, n) = \int_0^1 \frac{\{\gamma_r(p, q, \eta_0) - \gamma_r(p, q, n)\}}{(\eta_0 - n)} \eta_0^{q-1} (1 - \eta_0)^{p-q} d\eta_0. \quad (A-17)$$

From (A-17) we get directly

$$\begin{aligned} & \gamma_{r-1}(p, q, n) W_r(p, q, n) - \gamma_r(p, q, n) W_{r-1}(p, q, n) \\ &= \int_0^1 \frac{\{\gamma_{r-1}(p, q, n) \gamma_r(p, q, \eta_0) - \gamma_r(p, q, n) \gamma_{r-1}(p, q, \eta_0)\}}{(\eta_0 - n)} \eta_0^{q-1} (1 - \eta_0)^{p-1} d\eta_0. \quad (A-18) \end{aligned}$$

If we use the recurrence relation (A-7) to express $\gamma_r(p, q, \eta_0)$ in terms of $\gamma_{r-1}(p, q, \eta_0)$ and $\gamma_{r-2}(p, q, \eta_0)$ and to express $\gamma_r(p, q, n)$ in terms of $\gamma_{r-1}(p, q, n)$ and $\gamma_{r-2}(p, q, n)$ in the right-hand side of (A-18) we get

$$\begin{aligned} & \gamma_{r-1}(p, q, n) W_r(p, q, n) - \gamma_r(p, q, n) W_{r-1}(p, q, n) \\ &= -A_r(p, q) \gamma_{r-1}(p, q, n) \int_0^1 \gamma_{r-1}(p, q, \eta_0) \eta_0^{q-1} (1 - \eta_0)^{p-q} d\eta_0 \\ & \quad - (1 + B_r(p, q)) \int_0^1 \frac{\{\gamma_{r-2}(p, q, n) \gamma_{r-1}(p, q, \eta_0) - \gamma_{r-1}(p, q, n) \gamma_{r-2}(p, q, \eta_0)\}}{(\eta_0 - n)} \\ & \quad \quad \quad \times \eta_0^{q-1} (1 - \eta_0)^{p-q} d\eta_0 \\ &= D_r(p, q) \{\gamma_{r-2}(p, q, n) W_{r-1}(p, q, n) - \gamma_{r-1}(p, q, n) W_{r-2}(p, q, n)\} \quad r \geq 2. \quad (A-19) \end{aligned}$$

where

$$D_r(p, q) = - (1 + B_r(p, q))$$

$$= \frac{(r-1)(r+p-q-1)(2r+p-1)}{(r+p-1)(r+q-1)(2r+p-3)} \quad (A-20)$$

For $r = 1$ the relation corresponding to (A-19) is

$$\begin{aligned} & \gamma_0(p, q, n)W_1(p, q, n) - \gamma_1(p, q, n)W_0(p, q, n) \\ &= -A_1(p, q)\gamma_0(p, q, n) \int_0^1 \gamma_0(p, q, n_0)n_0^{q-1}(1-n_0)^{p-q}dn_0 \\ &= -\frac{(p+1)}{q} \int_0^1 n_0^{q-1}(1-n_0)^{p-q}dn_0 \quad (A-21) \end{aligned}$$

If we use relationship (A-19) repeatedly, followed by relationship (A-21), we get

$$\begin{aligned} & \gamma_{r-1}(p, q, n)W_r(p, q, n) - \gamma_r(p, q, n)W_{r-1}(p, q, n) \\ &= \left\{ \prod_{s=2}^r D_s(p, q) \right\} \{ \gamma_0(p, q, n)W_1(p, q, n) - \gamma_1(p, q, n)W_0(p, q, n) \} \\ &= -\frac{(p+1)}{q} \left\{ \prod_{s=2}^r D_s(p, q) \right\} \int_0^1 n_0^{q-1}(1-n_0)^{p-q}dn_0, \quad r \geq 2 \quad (A-22) \end{aligned}$$

On dividing equation (A-22) through by $\gamma_{r-1}(p, q, n)\gamma_r(p, q, n)$ and equation (A-21) through by $\gamma_0(p, q, n)\gamma_1(p, q, n)$ we get the equations

$$\frac{W_r(p, q, n)}{\gamma_r(p, q, n)} - \frac{W_{r-1}(p, q, n)}{\gamma_{r-1}(p, q, n)} = -\frac{(p+1)}{q} \int_0^1 n_0^{q-1}(1-n_0)^{p-q}dn_0 \frac{\left\{ \prod_{s=2}^r D_s(p, q) \right\}}{\gamma_r(p, q, n)\gamma_{r-1}(p, q, n)},$$

$$r \geq 2, \quad (A-23)$$

and

$$\frac{W_1(p, q, n)}{\gamma_1(p, q, n)} - \frac{W_0(p, q, n)}{\gamma_0(p, q, n)} = -\frac{(p+1)}{q} \int_0^1 n_0^{q-1} (1-n_0)^{p-q} d n_0 \frac{1}{\gamma_1(p, q, n) \gamma_0(p, q, n)} .$$

..... (A-24)

On summing the equations (A-23), $r = 2(1)m$, and (A-24) we get

$$\frac{W_m(p, q, n)}{\gamma_m(p, q, n)} - \frac{W_0(p, q, n)}{\gamma_0(p, q, n)} = -\frac{(p+1)}{q} \int_0^1 n_0^{q-1} (1-n_0)^{p-q} d n_0 \left\{ \frac{1}{\gamma_1(p, q, n) \gamma_0(p, q, n)} + \sum_{r=2}^m \frac{\left\{ \prod_{s=2}^r D_s(p, q) \right\}}{\gamma_r(p, q, n) \gamma_{r-1}(p, q, n)} \right\} ,$$

$m \geq 2$. (A-25)

Then, from (A-24) and (A-25) we get

$$W_1(p, q, n) = \gamma_1(p, q, n) \frac{W_0(p, q, n)}{\gamma_0(p, q, n)} - \frac{(p+1)}{q} \int_0^1 n_0^{q-1} (1-n_0)^{p-q} d n_0 \frac{1}{\gamma_0(p, q, n)} ,$$

(A-26a)

$$W_2(p, q, n) = \gamma_2(p, q, n) \left[\frac{W_0(p, q, n)}{\gamma_0(p, q, n)} - \frac{(p+1)}{q} \int_0^1 n_0^{q-1} (1-n_0)^{p-q} d n_0 \frac{1}{\gamma_1(p, q, n) \gamma_0(p, q, n)} \right] - \frac{(p+1)}{q} \int_0^1 n_0^{q-1} (1-n_0)^{p-q} d n_0 \frac{D_2(p, q)}{\gamma_{m-1}(p, q, n)} ,$$

(A-26b)

$$\begin{aligned}
 W_m(p, q, n) = & \gamma_m(p, q, n) \left[\frac{W_0(p, q, n)}{\gamma_0(p, q, n)} - \frac{(p+1)}{q} \int_0^1 \eta_0^{q-1} (1-\eta_0)^{p-q} d\eta_0 \right. \\
 & \times \left. \left\{ \frac{1}{\gamma_1(p, q, n) \gamma_0(p, q, n)} + \sum_{r=2}^{m-1} \frac{\left\{ \prod_{s=2}^r D_s(p, q) \right\}}{\gamma_r(p, q, n) \gamma_{r-1}(p, q, n)} \right\} \right] \\
 & - \frac{(p+1)}{q} \int_0^1 \eta_0^{q-1} (1-\eta_0)^{p-q} d\eta_0 \frac{\left\{ \prod_{s=2}^m D_s(p, q) \right\}}{\gamma_{m-1}(p, q, n)}, \quad m \geq 3. \quad (A-26c)
 \end{aligned}$$

By using the formula (A-20) for $D_r(p, q)$ we can show that

$$\prod_{s=2}^m D_s(p, q) = \frac{(2m+p-1)}{(p+1)} \frac{\Gamma(m)}{\Gamma(m+q)} \frac{\Gamma(m+p-q)}{\Gamma(m+p)} \frac{\Gamma(1+q)\Gamma(1+p)}{\Gamma(1+p-q)}, \quad (A-27)$$

$m \geq 2,$

and we have immediately that

$$1 = \left[\frac{(2m+p-1)}{(p+1)} \frac{\Gamma(m)}{\Gamma(m+q)} \frac{\Gamma(m+p-q)}{\Gamma(m+p)} \frac{\Gamma(1+q)\Gamma(1+p)}{\Gamma(1+p-q)} \right]_{m=1}. \quad (A-28)$$

By using formula (A-8) we can show that

$$\gamma_{m-1}(p, q, \eta_k(p, q, m)) = - \frac{1}{m C_m(p, q)} \left[n(1-n) \frac{d}{dn} \gamma_m(p, q, n) \right]_{n=\eta_k(p, q, m)}. \quad (A-29)$$

By using formulae (A-27), (A-28) and (A-29) in (A-26a), (A-26b) or (A-26c) we can obtain an expression for $W_m(p, q, \eta_k(p, q, m))$, $m \geq 1$, for substituting into formula (A-16) to get

$$\begin{aligned}
 G_k(p, q, m) = & \frac{m(2m+p-1)}{q} \frac{\Gamma(m)}{\Gamma(m+q)} \frac{\Gamma(m+p-q)}{\Gamma(m+p)} \frac{\Gamma(1+q)\Gamma(1+p)}{\Gamma(1+p-q)} C_m(p, q) \\
 & \times \frac{1}{\left[n(1-n) \left\{ \frac{d}{dn} \gamma_m(p, q, n) \right\}^2 \right]_{n=\eta_k(p, q, m)}} \int_0^1 \eta_0^{q-1} (1-\eta_0)^{p-q} d\eta_0. \quad (A-30)
 \end{aligned}$$

In particular, we get from formula (A-30),

$$G_k\left(\frac{3}{2}, 1, m\right) = \frac{1}{\left[\eta(1-\eta) \left\{ \frac{d}{d\eta} \gamma_m\left(\frac{3}{2}, 1, \eta\right) \right\}^2 \right]_{\eta=\eta_k\left(\frac{3}{2}, 1, m\right)}} \quad (\text{A-31})$$

and

$$G_k\left(\frac{3}{2}, 2, m\right) = \frac{2}{(m+1)(2m+3)} \frac{1}{\left[\eta(1-\eta) \left\{ \frac{d}{d\eta} \gamma_m\left(\frac{3}{2}, 1, \eta\right) \right\}^2 \right]_{\eta=\eta_k\left(\frac{3}{2}, 1, m\right)}} \quad (\text{A-32})$$

If we wish to obtain a numerical integration formula for the integral

$$\int_0^1 F(\eta) \sqrt{1-\eta} \, d\eta \quad (\text{A-33})$$

where one of the integration points is the point $\eta = 0$, we write

$$\int_0^1 F(\eta) \sqrt{1-\eta} \, d\eta = F(0) \int_0^1 \sqrt{1-\eta} \, d\eta + \int_0^1 \left\{ \frac{F(\eta) - F(0)}{\eta} \right\} \eta \sqrt{1-\eta} \, d\eta \quad (\text{A-34})$$

and apply the numerical integration formula (A-5), with $q = 2$, $p = \frac{3}{2}$ and m replaced by $m - 1$, to the second integral on the right-hand side of formula (A-34). We then get

$$\begin{aligned} \int_0^1 F(\eta) \sqrt{1-\eta} \, d\eta &= \frac{2}{3} F(0) + \sum_{k=1}^{m-1} \frac{\left\{ F\left(\eta_k\left(\frac{3}{2}, 2, m-1\right)\right) - F(0) \right\}}{\eta_k\left(\frac{3}{2}, 2, m-1\right)} G_k\left(\frac{3}{2}, 2, m-1\right) \\ &= F(0) \left\{ \frac{2}{3} - \sum_{k=1}^{m-1} \frac{G_k\left(\frac{3}{2}, 2, m-1\right)}{\eta_k\left(\frac{3}{2}, 2, m-1\right)} \right\} \\ &\quad + \sum_{k=1}^{m-1} F\left(\eta_k\left(\frac{3}{2}, 2, m-1\right)\right) \frac{G_k\left(\frac{3}{2}, 2, m-1\right)}{\eta_k\left(\frac{3}{2}, 2, m-1\right)}. \quad (\text{A-35}) \end{aligned}$$

The formula (A-35) is to be compared with the formula

$$\int_0^1 F(\eta) \sqrt{1-\eta} \, d\eta = \sum_{k=1}^m F(\eta_k^{(m)}) G_k^{(m)} \quad (\text{A-36})$$

which conforms with formula (2-64) of the main text. Thus we have

$$\eta_1^{(m)} = 0, \quad (\text{A-37a})$$

$$\eta_k^{(m)} = \eta_{k-1}^{(m)} \left(\frac{2}{3}, 2, m-1 \right), \quad k = 2(1)m, \quad (\text{A-37b})$$

and

$$G_1^{(m)} = \frac{2}{3} - \sum_{j=1}^{m-1} \frac{G_j \left(\frac{2}{3}, 2, m-1 \right)}{\eta_j \left(\frac{2}{3}, 2, m-1 \right)}, \quad (\text{A-38a})$$

$$G_k^{(m)} = \frac{G_{k-1} \left(\frac{2}{3}, 2, m-1 \right)}{\eta_{k-1} \left(\frac{2}{3}, 2, m-1 \right)}. \quad (\text{A-38b})$$

If there is no restriction on the integration points η we apply the integration formula (A-5) directly with $q = 1$, $p = \frac{2}{3}$ to obtain a numerical integration formula for the integral (A-33). If we replace m by \bar{m} in (A-5) we get

$$\int_0^1 F(\eta) \sqrt{1-\eta} \, d\eta = \sum_{k=1}^{\bar{m}} F(\eta_k \left(\frac{2}{3}, 1, \bar{m} \right)) G_k \left(\frac{2}{3}, 1, \bar{m} \right), \quad (\text{A-39})$$

which is to be compared with formula (3-1) of the main text. On comparing the appropriate quantities we get

$$\zeta_k^{(\bar{m})} = \eta_k \left(\frac{2}{3}, 1, \bar{m} \right), \quad k = 1(1)\bar{m}, \quad (\text{A-40})$$

and

$$\bar{G}_k^{(\bar{m})} = G_k \left(\frac{2}{3}, 1, \bar{m} \right), \quad k = 1(1)\bar{m}. \quad (\text{A-41})$$

It is interesting to note that

$$\gamma_r \left(\frac{2}{3}, 1, \eta \right) = \frac{1}{\sqrt{1-\eta}} P_{2r+1}(\sqrt{1-\eta}) \quad (\text{A-42})$$

where $P_r(u)$ is the Legendre polynomial of degree r in u . The integration points $\zeta_k^{(\bar{m})}$ of formula (A-40) therefore satisfy

$$\frac{P_{2\bar{m}+1}(\sqrt{1-\zeta_k^{(\bar{m})}})}{\sqrt{1-\zeta_k^{(\bar{m})}}} = 0, \quad j = 1(1)\bar{m}, \quad (\text{A-43})$$

and the formula (A-31) for the integration weights may be written

$$\bar{G}_k^{(\bar{m})} = G_k(\frac{1}{2}, 1, \bar{m}) = \left[\frac{4u^2}{(1-u^2)} \frac{1}{\left\{ \frac{d}{du} P_{2\bar{m}+1}(u) \right\}^2} \right]_{u=\sqrt{1-\zeta_k^{(\bar{m})}}}. \quad (\text{A-44})$$

The integration points $\chi_j^{(m', \bar{m})}$, $j = 1(1)m'$, are defined in formula (3-6). To obtain the corresponding integration multipliers we proceed as follows. Write, as an approximation to $F(\eta)$,

$$F(\eta) = \sum_{j=1}^{m'} F(\chi_j^{(m', \bar{m})}) \prod_{\substack{p=1 \\ p \neq j}}^{m'} \left(\frac{\eta - \chi_p^{(m', \bar{m})}}{\chi_j^{(m', \bar{m})} - \chi_p^{(m', \bar{m})}} \right) \quad (\text{A-45})$$

and use the integration formula (3-1) to get

$$\begin{aligned} \int_0^1 F(\eta) \sqrt{1-\eta} \, d\eta &= \sum_{k=1}^{\bar{m}} \bar{G}_k^{(\bar{m})} \sum_{j=1}^{m'} F(\chi_j^{(m', \bar{m})}) \prod_{\substack{p=1 \\ p \neq j}}^{m'} \left(\frac{\zeta_k^{(\bar{m})} - \chi_p^{(m', \bar{m})}}{\chi_j^{(m', \bar{m})} - \chi_p^{(m', \bar{m})}} \right) \\ &= \sum_{j=1}^{m'} F(\chi_j^{(m', \bar{m})}) \sum_{k=1}^{\bar{m}} \bar{G}_k^{(\bar{m})} \prod_{\substack{p=1 \\ p \neq j}}^{m'} \left(\frac{\zeta_k^{(\bar{m})} - \chi_p^{(m', \bar{m})}}{\chi_j^{(m', \bar{m})} - \chi_p^{(m', \bar{m})}} \right) \end{aligned} \quad (\text{A-46})$$

which is to be compared with formula (3-7) of the main text. On making the comparison we get

$$G_j^{(m', \bar{m})} = \sum_{k=1}^{\bar{m}} \bar{G}_k^{(\bar{m})} \prod_{\substack{p=1 \\ p \neq j}}^{m'} \left(\frac{\zeta_k^{(\bar{m})} - \chi_p^{(m', \bar{m})}}{\chi_j^{(m', \bar{m})} - \chi_p^{(m', \bar{m})}} \right) \quad j = 1(1)m'. \quad (\text{A-47})$$

Appendix B

NUMERICAL EVALUATION AT $\eta_0 = \chi_q^{(m'_1, \bar{m}_1)}$ OF $I_r^{(n)*}(\bar{\xi}_p^{(n'_1)}, \chi_q^{(m'_1, \bar{m}_1)}, \eta_0; \nu, M)$
 AND ITS FIRST TWO DERIVATIVES WITH RESPECT TO η_0

We recall from formula (3-21) that

$$I_r^{(n)}\left(\bar{\xi}_p^{(n'_1)}, \chi_q^{(m'_1, \bar{m}_1)}, \eta_0; \nu, M\right) = \left(\chi_q^{(m'_1, \bar{m}_1)} - \eta_0\right)^2 \int_0^1 h_r^{(n)}(\xi_0) K_1\left(\frac{\bar{x}_p^{(n'_1, m'_1, \bar{m}_1)} - x_0}{\ell}, \frac{z_q^{(m'_1, \bar{m}_1)} - z_0}{\ell}; \nu, M\right) \sqrt{\frac{1 - \xi_0}{\xi_0}} d\xi_0, \quad \dots\dots (B-1)$$

where, according to formula (2-20),

$$K_1(x, y; \nu, M) = \left[\int_{\frac{-x+MR}{\beta^2}}^{\infty} \exp(-i\nu\lambda) \frac{d\lambda}{(\lambda^2 + y^2)^{\frac{1}{2}}} + \frac{M(Mx+R)}{R(x^2 + y^2)} \exp\left(-\frac{i\nu(-x+MR)}{\beta^2}\right) \right] \quad \dots\dots (B-2)$$

with

$$\beta^2 = 1 - M^2 \quad (B-3)$$

and

$$R = R(x, y, \beta) = \sqrt{x^2 + \beta^2 y^2}. \quad (B-4)$$

For the purpose of evaluating the required quantities the formula (B-2) is recast into a more convenient form by changing the variable of integration from λ to u according to the formula

$$\lambda = -\frac{1}{\beta^2} \left[u - M\sqrt{u^2 + \beta^2 y^2} \right] \quad (B-5)$$

in the integral on the right-hand side of (B-2). Then

$$\frac{d\lambda}{du} = -\frac{1}{\beta^2} \frac{\left[\sqrt{u^2 + \beta^2 y^2} - Mu \right]}{\sqrt{u^2 + \beta^2 y^2}} \quad (B-6)$$

and

$$\sqrt{\lambda^2 + y^2} = \frac{1}{\beta^2} \left[\sqrt{u^2 + \beta^2 y^2} - Mu \right] . \quad (\text{B-7})$$

When $\lambda = +\infty$, $u = -\infty$ and when $\lambda = (-x + MR)/\beta^2$, $u = x$. Therefore

$$\begin{aligned} & \int_{\frac{-x+MR}{\beta^2}}^{\infty} \exp(-i\nu\lambda) \frac{d\lambda}{(\lambda^2 + y^2)^{\frac{3}{2}}} \\ &= \beta^4 \int_{-\infty}^x \frac{\exp\left[\frac{i\nu}{\beta^2}(u - M\sqrt{u^2 + \beta^2 y^2})\right]}{\left(\sqrt{u^2 + \beta^2 y^2} - Mu\right)^2} \frac{du}{\sqrt{u^2 + \beta^2 y^2}} \\ &= \frac{\beta^2}{My^2} \int_{-\infty}^x \exp\left[\frac{i\nu}{\beta^2}(u - M\sqrt{u^2 + \beta^2 y^2})\right] \frac{d}{du} \left[\frac{\sqrt{u^2 + \beta^2 y^2}}{\left(\sqrt{u^2 + \beta^2 y^2} - Mu\right)} - \frac{1}{(1+M)} \right] du \\ &= \frac{\beta^2}{My^2} \left[\exp\left[\frac{i\nu}{\beta^2}(u - M\sqrt{u^2 + \beta^2 y^2})\right] \left[\frac{\sqrt{u^2 + \beta^2 y^2}}{\left(\sqrt{u^2 + \beta^2 y^2} - Mu\right)} - \frac{1}{(1+M)} \right] \right]_{u=-\infty}^x \\ &\quad - \frac{i\nu}{My^2} \int_{-\infty}^x \exp\left[\frac{i\nu}{\beta^2}(u - M\sqrt{u^2 + \beta^2 y^2})\right] \left[\frac{\sqrt{u^2 + \beta^2 y^2}}{\left(\sqrt{u^2 + \beta^2 y^2} - Mu\right)} - \frac{1}{(1+M)} \right] \left[1 - \frac{Mu}{\sqrt{u^2 + \beta^2 y^2}} \right] du \\ &= \frac{\beta^2}{My^2} \exp\left(-i\nu \frac{(-x + MR)}{\beta^2}\right) \left[\frac{R(Mx + R)}{\beta^2(x^2 + y^2)} - \frac{1}{(1+M)} \right] \\ &\quad - \frac{i\nu}{(1+M)} \frac{1}{y^2} \int_{-\infty}^x \exp\left[\frac{i\nu}{\beta^2}(u - M\sqrt{u^2 + \beta^2 y^2})\right] \left[1 + \frac{u}{\sqrt{u^2 + \beta^2 y^2}} \right] du . \quad (\text{B-8}) \end{aligned}$$

On replacing the integral in formula (B-2) by the right-hand side of formula (B-8) we get

$$K_1(x, y, \nu, M) = \frac{1}{y^2} \left\{ \left(1 + \frac{x}{R}\right) \exp\left(-i\nu \frac{(-x + MR)}{\beta^2}\right) - \frac{i\nu}{(1 + M)} \int_{-\infty}^x \exp\left[\frac{i\nu}{\beta^2} \left(u - M\sqrt{u^2 + \beta^2 y^2}\right)\right] \left[1 + \frac{u}{\sqrt{u^2 + \beta^2 y^2}}\right] du \right\} .$$

..... (B-9)

We now introduce the function $L(x, y; \nu, M_\infty)$ by means of the formula

$$L(x, y; \nu, M) = y^2 K_1(x, y; \nu, M)$$

$$= \left(1 + \frac{x}{R}\right) \exp\left(-i\nu \frac{(-x + MR)}{\beta^2}\right) - \frac{i\nu}{(1 + M)} \int_{-\infty}^x \exp\left[\frac{i\nu}{\beta^2} \left(u - M\sqrt{u^2 + \beta^2 y^2}\right)\right] \left[1 + \frac{u}{\sqrt{u^2 + \beta^2 y^2}}\right] du .$$

..... (B-10)

The formula (B-1) may then be rewritten as

$$I_r^{(n)} \left(\bar{\xi}_p^{(n_1')}, \chi_q^{(m_1', \bar{m}_1)}, \eta_0; \nu, M \right)$$

$$= \frac{\ell^2}{s_1} \int_0^1 h_r^{(n)}(\xi_0) L \left(\frac{\bar{x}^{(n_1', m_1', \bar{m}_1)} - x_0}{\ell}, \frac{z_q^{(m_1', \bar{m}_1)} - z_0}{\ell}; \nu, M \right) \sqrt{\frac{1 - \xi_0}{\xi_0}} d\xi_0 .$$

..... (B-11)

We introduce the quantities $\xi_1(x, z_0)$ and $\sigma(z, z_0)$ by means of the formulae

$$\xi_1(x, z_0) = \frac{1}{c_1(z_0)} (x - e_1(z_0)) \tag{B-12}$$

and

$$\sigma(z, z_0) = \frac{(z - z_0)}{c_1(z_0)} . \tag{B-13}$$

We then get, from the definition of ξ_0 given in formula (2-27) of the main text,

$$\xi_0 = \xi_1(x_0, z_0) \quad (\text{B-14})$$

and from (B-10)

$$L\left(\frac{x-x_0}{l}, \frac{z-z_0}{l}; \nu, M\right) = \hat{L}\left(\xi_1(x, z_0) - \xi_1(x_0, z_0), \sigma(z, z_0); \frac{\nu c_1(z_0)}{l}, M\right) \quad (\text{B-15})$$

where

$$\begin{aligned} \hat{L}(\xi, \sigma; \mu, M) = & \left(1 + \frac{\xi}{\sqrt{\xi^2 + \beta^2 \sigma^2}}\right) \exp\left\{-i\mu \frac{(-\xi + M\sqrt{\xi^2 + \beta^2 \sigma^2})}{\beta^2}\right\} \\ & - \frac{i\mu}{(1+M)} \int_{-\infty}^{\xi} \exp\left\{\frac{i\mu}{\beta^2}(u - M\sqrt{u^2 + \beta^2 \sigma^2})\right\} \left\{1 + \frac{u}{\sqrt{u^2 + \beta^2 \sigma^2}}\right\} du \quad . \\ & \dots\dots (\text{B-16}) \end{aligned}$$

On substituting for L from formula (B-15) into formula (B-11) we get

$$\begin{aligned} I_r^{(n)}\left(\bar{\xi}_p^{(n)'}; \chi_q^{(m_1', \bar{m}_1)}, \eta_0; \nu, M\right) \\ = \frac{l^2}{s_1} G_r^{(r)}\left(\xi_1\left(\bar{x}_{p,q}^{(n_1', m_1', \bar{m}_1)}, z_0\right), \sigma\left(s_1 \chi_q^{(m_1', \bar{m}_1)}, z_0\right); \frac{\nu c_1(z_0)}{l}, M\right) \quad (\text{B-17}) \end{aligned}$$

where

$$G_r^{(n)}(\xi, \sigma; \mu, M) = \int_0^1 h_r^{(n)}(\xi_0) \hat{L}(\xi - \xi_0, \sigma; \mu, M) \sqrt{\frac{1 - \xi_0}{\xi_0}} d\xi_0 \quad . \quad (\text{B-18})$$

We now show that we may write

$$\begin{aligned} G_r^{(n)}(\xi, \sigma; \mu, M) = & E_r^{(n)}(\xi; \mu, M) + \frac{1}{2} \sigma^2 D_r^{(n)}(\xi, \sigma; \mu, M) \\ & + \frac{1}{2} \sigma^2 \log(\sigma^2) F_r^{(n)}(\xi, \sigma; \mu, M) \quad (\text{B-19}) \end{aligned}$$

where the functions $D_r^{(n)}(\xi, \sigma; \mu, M)$ and $F_r^{(n)}(\xi, \sigma; \mu, M)$ remain finite when $|\sigma| \rightarrow 0$.

From formula (B-16) we get

$$\hat{L}(\xi, 0; \mu, M) = \begin{cases} 2 & \xi > 0 \\ 0 & \xi < 0 \end{cases} \quad (\text{B-20})$$

Then, from (B-18), we get

$$G_r^{(n)}(\xi, 0; \mu, M) = \begin{cases} 2 \int_0^\xi h_r^{(n)}(\xi_0) \sqrt{\frac{1-\xi_0}{\xi_0}} d\xi_0 & 0 \leq \xi \leq 1 \\ 0 & \xi < 0 \end{cases} \quad (\text{B-21})$$

If we write $G_r^{(n)}(\xi, \sigma; \mu, M)$ in the form (B-19) we find, on putting $\sigma = 0$, that

$$E_r^{(n)}(\xi; \mu, M) = G_r^{(n)}(\xi, 0; \mu, M) = \begin{cases} 2 \int_0^\xi h_r^{(n)}(\xi_0) \sqrt{\frac{1-\xi_0}{\xi_0}} d\xi_0 & 0 \leq \xi \leq 1 \\ 0 & \xi < 0 \end{cases} \quad (\text{B-22})$$

If we differentiate the formula (B-19) for $G_r^{(n)}(\xi, \sigma; \mu, M)$ with respect to σ we get

$$\begin{aligned} \frac{d}{d\sigma} G_r^{(n)}(\xi, \sigma; \mu, M) &= \sigma D_r^{(n)}(\xi, \sigma; \mu, M) + \frac{1}{2} \sigma^2 \frac{d}{d\sigma} D_r^{(n)}(\xi, \sigma; \mu, M) \\ &+ \sigma(1 + \log(\sigma^2)) F_r^{(n)}(\xi, \sigma; \mu, M) + \frac{1}{2} \sigma^2 \log(\sigma^2) \frac{d}{d\sigma} F_r^{(n)}(\xi, \sigma; \mu, M) . \\ &\dots\dots (\text{B-23}) \end{aligned}$$

Therefore, if the formula (B-19) is valid, we shall have

$$\begin{aligned} \lim_{\sigma \rightarrow 0} \left\{ \frac{1}{\sigma} \frac{d}{d\sigma} G_r^{(n)}(\xi, \sigma; \mu, M) - \log(\sigma^2) F_r^{(n)}(\xi, 0; \mu, M) \right\} \\ = D_r^{(n)}(\xi, 0; \mu, M) + F_r^{(n)}(\xi, 0; \mu, M) . \end{aligned} \quad (\text{B-24})$$

Now, by using the definition (B-18) of $G_r^{(n)}(\xi, \sigma; \mu, M)$ we get

$$\frac{1}{\sigma} \frac{d}{d\sigma} G_r^{(n)}(\xi, \sigma; \mu, M) = \int_0^1 h_r^{(n)}(\xi_0) \frac{1}{\sigma} \frac{d}{d\sigma} \hat{L}(\xi - \xi_0, \sigma; \mu, M) \sqrt{\frac{1 - \xi_0}{\xi_0}} d\xi_0. \quad (B-25)$$

It is convenient, for our further analysis, to write

$$\frac{1}{\sigma} \frac{d}{d\sigma} \hat{L}(\xi, \sigma; \mu, M) = A(\xi, \sigma; \mu, M) + B(\xi, \sigma; \mu, M) \quad (B-26)$$

where

$$A(\xi, \sigma; \mu, M) = - \left[\frac{\beta^2 \xi}{(\xi^2 + \beta^2 \sigma^2)^{\frac{3}{2}}} + \frac{i\mu M}{(\xi^2 + \beta^2 \sigma^2)^{\frac{1}{2}}} \left(1 + \frac{\xi}{(\xi^2 + \beta^2 \sigma^2)^{\frac{1}{2}}} \right) \right] \\ \times \exp \left\{ - \frac{i\mu}{\beta^2} \left(-\xi + M(\xi^2 + \beta^2 \sigma^2)^{\frac{1}{2}} \right) \right\} \quad (B-27)$$

and

$$B(\xi, \sigma; \mu, M) = \frac{i\mu}{(1+M)} \int_{-\infty}^{\xi} \left[\frac{\beta^2 u}{(u^2 + \beta^2 \sigma^2)^{\frac{3}{2}}} + \frac{i\mu M}{(u^2 + \beta^2 \sigma^2)^{\frac{1}{2}}} \left(1 + \frac{u}{(u^2 + \beta^2 \sigma^2)^{\frac{1}{2}}} \right) \right] \\ \times \exp \left\{ - \frac{i\mu}{\beta^2} \left(-u + M(u^2 + \beta^2 \sigma^2)^{\frac{1}{2}} \right) \right\} d\xi. \quad (B-28)$$

Then, if $0 < \xi < 1$, we have

$$\int_0^1 h_r^{(n)}(\xi_0) A(\xi - \xi_0, \sigma; \mu, M) \sqrt{\frac{1 - \xi_0}{\xi_0}} d\xi_0 \\ = - \int_0^1 h_r^{(n)}(\xi_0) \sqrt{\frac{1 - \xi_0}{\xi_0}} \exp \left\{ \frac{i\mu}{\beta^2} \left(\xi - \xi_0 - M((\xi - \xi_0)^2 + \beta^2 \sigma^2)^{\frac{1}{2}} \right) \right\} \\ \times \left[\frac{\beta^2 (\xi - \xi_0)}{\{(\xi - \xi_0)^2 + \beta^2 \sigma^2\}^{\frac{3}{2}}} + \frac{i\mu M}{\{(\xi - \xi_0)^2 + \beta^2 \sigma^2\}^{\frac{1}{2}}} \left(1 + \frac{(\xi - \xi_0)}{\{(\xi - \xi_0)^2 + \beta^2 \sigma^2\}^{\frac{1}{2}}} \right) \right] d\xi_0$$

$$\begin{aligned}
& - \left(\int_0^{\xi-\delta} + \int_{\xi+\delta}^1 \right) h_r^{(n)}(\xi_0) \sqrt{\frac{1-\xi_0}{\xi_0}} \exp\left\{ \frac{i\mu}{\beta^2} (\xi - \xi_0 - M((\xi - \xi_0)^2 + \beta^2 \sigma^2)^{\frac{1}{2}}) \right\} \\
& \quad \times \left[\frac{\beta^2 (\xi - \xi_0)}{\{(\xi - \xi_0)^2 + \beta^2 \sigma^2\}^{\frac{3}{2}}} + \frac{i\mu M}{\{(\xi - \xi_0)^2 + \beta^2 \sigma^2\}^{\frac{3}{2}}} \left(1 + \frac{(\xi - \xi_0)}{\{(\xi - \xi_0)^2 + \beta^2 \sigma^2\}^{\frac{1}{2}}} \right) \right] d\xi_0 \\
& - \int_{\xi-\delta}^{\xi+\delta} \left\{ h_r^{(n)}(\xi_0) \sqrt{\frac{1-\xi_0}{\xi_0}} - h_r^{(n)}(\xi) \sqrt{\frac{1-\xi}{\xi}} + (\xi - \xi_0) \frac{d}{d\xi} \left(h_r^{(n)}(\xi) \sqrt{\frac{1-\xi}{\xi}} \right) \right\} \\
& \quad \times \frac{\beta^2 (\xi - \xi_0)}{\{(\xi - \xi_0)^2 + \beta^2 \sigma^2\}^{\frac{3}{2}}} \exp\left\{ \frac{i\mu}{\beta^2} (\xi - \xi_0 - M((\xi - \xi_0)^2 + \beta^2 \sigma^2)^{\frac{1}{2}}) \right\} d\xi_0 \\
& - h_r^{(n)}(\xi) \sqrt{\frac{1-\xi}{\xi}} \int_{\xi-\delta}^{\xi+\delta} \frac{\beta^2 (\xi - \xi_0)}{\{(\xi - \xi_0)^2 + \beta^2 \sigma^2\}^{\frac{3}{2}}} \left[\exp\left\{ \frac{i\mu}{\beta^2} (\xi - \xi_0 - M((\xi - \xi_0)^2 + \beta^2 \sigma^2)^{\frac{1}{2}}) \right\} - 1 \right. \\
& \quad \left. - \frac{i\mu}{\beta^2} (\xi - \xi_0 - M((\xi - \xi_0)^2 + \beta^2 \sigma^2)^{\frac{1}{2}}) \right] d\xi_0 \\
& + \frac{d}{d\xi} \left(h_r^{(n)}(\xi) \sqrt{\frac{1-\xi}{\xi}} \right) \int_{\xi-\delta}^{\xi+\delta} \frac{\beta^2 (\xi - \xi_0)^2}{\{(\xi - \xi_0)^2 + \beta^2 \sigma^2\}^{\frac{3}{2}}} \\
& \quad \times \left[\exp\left\{ \frac{i\mu}{\beta^2} (\xi - \xi_0 - M((\xi - \xi_0)^2 + \beta^2 \sigma^2)^{\frac{1}{2}}) \right\} - 1 \right] d\xi_0 \\
& - (i\mu M) \int_{\xi-\delta}^{\xi+\delta} \left\{ h_r^{(n)}(\xi_0) \sqrt{\frac{1-\xi_0}{\xi_0}} - h_r^{(n)}(\xi) \sqrt{\frac{1-\xi}{\xi}} \right\} \frac{1}{\{(\xi - \xi_0)^2 + \beta^2 \sigma^2\}^{\frac{3}{2}}} \\
& \quad \times \left(1 + \frac{(\xi - \xi_0)}{\{(\xi - \xi_0)^2 + \beta^2 \sigma^2\}^{\frac{1}{2}}} \right) \exp\left\{ \frac{i\mu}{\beta^2} (\xi - \xi_0 - M((\xi - \xi_0)^2 + \beta^2 \sigma^2)^{\frac{1}{2}}) \right\} d\xi_0
\end{aligned}$$

$$\begin{aligned}
& - (i\mu M) h_r^{(n)}(\xi) \sqrt{\frac{1-\xi}{\xi}} \int_{\xi-\delta}^{\xi+\delta} \frac{1}{\left\{(\xi-\xi_0)^2 + \beta^2 \sigma^2\right\}^{\frac{1}{2}}} \left(1 + \frac{(\xi-\xi_0)}{\left\{(\xi-\xi_0)^2 + \beta^2 \sigma^2\right\}^{\frac{1}{2}}}\right) \\
& \quad \times \left[\exp\left\{\frac{i\mu}{\beta^2} (\xi-\xi_0 - M \left\{(\xi-\xi_0)^2 + \beta^2 \sigma^2\right\}^{\frac{1}{2}})\right\} - 1 \right] d\xi_0 \\
& - h_r^{(n)}(\xi) \sqrt{\frac{1-\xi}{\xi}} \int_{\xi-\delta}^{\xi+\delta} \frac{\beta^2 (\xi-\xi_0)}{\left\{(\xi-\xi_0)^2 + \beta^2 \sigma^2\right\}^{\frac{3}{2}}} \left[1 + \frac{i\mu}{\beta^2} (\xi-\xi_0 - M \left\{(\xi-\xi_0)^2 + \beta^2 \sigma^2\right\}^{\frac{1}{2}})\right] d\xi_0 \\
& + \frac{d}{d\xi} \left(h_r^{(n)}(\xi) \sqrt{\frac{1-\xi}{\xi}} \right) \int_{\xi-\delta}^{\xi+\delta} \frac{\beta^2 (\xi-\xi_0)^2}{\left\{(\xi-\xi_0)^2 + \beta^2 \sigma^2\right\}^{\frac{3}{2}}} d\xi_0 \\
& - (i\mu M) h_r^{(n)}(\xi) \sqrt{\frac{1-\xi}{\xi}} \int_{\xi-\delta}^{\xi+\delta} \frac{1}{\left\{(\xi-\xi_0)^2 + \beta^2 \sigma^2\right\}^{\frac{1}{2}}} \left(1 + \frac{(\xi-\xi_0)}{\left\{(\xi-\xi_0)^2 + \beta^2 \sigma^2\right\}^{\frac{1}{2}}}\right) d\xi_0 \\
& - \left(\int_0^{\xi-\delta} + \int_{\xi+\delta}^1 \right) h_r^{(n)}(\xi_0) \sqrt{\frac{1-\xi_0}{\xi_0}} \exp\left\{\frac{i\mu}{\beta^2} (\xi-\xi_0 - M \left\{(\xi-\xi_0)^2 + \beta^2 \sigma^2\right\}^{\frac{1}{2}})\right\} \\
& \quad \times \left[\frac{\beta^2 (\xi-\xi_0)}{\left\{(\xi-\xi_0)^2 + \beta^2 \sigma^2\right\}^{\frac{3}{2}}} + \frac{i\mu M}{\left\{(\xi-\xi_0)^2 + \beta^2 \sigma^2\right\}^{\frac{1}{2}}} \left(1 + \frac{(\xi-\xi_0)}{\left\{(\xi-\xi_0)^2 + \beta^2 \sigma^2\right\}^{\frac{1}{2}}}\right) \right] d\xi_0 \\
& + 2\beta^2 \left[\frac{d}{d\xi} \left(h_r^{(n)}(\xi) \sqrt{\frac{1-\xi}{\xi}} \right) - \frac{i\mu}{\beta^2} h_r^{(n)}(\xi) \sqrt{\frac{1-\xi}{\xi}} \right] \left[\log\left(\frac{\sqrt{\delta^2 + \beta^2 \sigma^2} + \delta}{\beta|\sigma|}\right) - \frac{\delta}{\sqrt{\delta^2 + \beta^2 \sigma^2}} \right] \\
& - 2(i\mu M) h_r^{(n)}(\xi) \sqrt{\frac{1-\xi}{\xi}} \log\left(\frac{\sqrt{\delta^2 + \beta^2 \sigma^2} + \delta}{\beta|\sigma|}\right) + o(\delta) .
\end{aligned}$$

(B-29)

where δ is an arbitrary positive number which is such that

$$0 < \xi - \delta < \xi + \delta < 1. \quad (\text{B-30})$$

We get directly from formula (B-29)

$$\begin{aligned} \lim_{|\sigma| \rightarrow 0} & \left\{ \int_0^1 h_r^{(n)}(\xi_0) A(\xi - \xi_0, \sigma; \mu, M) \sqrt{\frac{1 - \xi_0}{\xi_0}} d\xi_0 \right. \\ & \left. + \log(\sigma^2) \left[\beta^2 \frac{d}{d\xi} \left(h_r^{(n)}(\xi) \sqrt{\frac{1 - \xi}{\xi}} \right) - i\mu(1 + M) h_r^{(n)}(\xi) \sqrt{\frac{1 - \xi}{\xi}} \right] \right\} \\ & - \int_0^{\xi - \delta} h_r^{(n)}(\xi_0) \sqrt{\frac{1 - \xi_0}{\xi_0}} \exp\left(\frac{i\mu(\xi - \xi_0)}{(1 + M)}\right) \left[\frac{\beta^2}{(\xi - \xi_0)^2} + \frac{2i\mu M}{(\xi - \xi_0)} \right] d\xi_0 \\ & + \int_{\xi + \delta}^1 h_r^{(n)}(\xi_0) \sqrt{\frac{1 - \xi_0}{\xi_0}} \exp\left(\frac{i\mu(\xi - \xi_0)}{(1 - M)}\right) \frac{\beta^2}{(\xi - \xi_0)^2} d\xi_0 \\ & + 2\beta^2 \frac{d}{d\xi} \left(h_r^{(n)}(\xi) \sqrt{\frac{1 - \xi}{\xi}} \right) \left(\log\left(\frac{2\delta}{\beta}\right) - 1 \right) \\ & - 2(i\mu) h_r^{(n)}(\xi) \sqrt{\frac{1 - \xi}{\xi}} \left((1 + M) \log\left(\frac{2\delta}{\beta}\right) - 1 \right) + o(\delta) \quad (\text{B-31}) \end{aligned}$$

Now,

$$\begin{aligned} & - \int_0^{\xi - \delta} h_r^{(n)}(\xi_0) \sqrt{\frac{1 - \xi_0}{\xi_0}} \exp\left(\frac{i\mu(\xi - \xi_0)}{(1 + M)}\right) \frac{\beta^2}{(\xi - \xi_0)^2} d\xi_0 \\ & - \frac{\beta^2}{\xi} \int_0^{\xi - \delta} h_r^{(n)}(\xi_0) \sqrt{\frac{1 - \xi_0}{\xi_0}} \exp\left(\frac{i\mu(\xi - \xi_0)}{(1 + M)}\right) \frac{d}{d\xi_0} \left(\frac{\xi_0}{\xi - \xi_0} \right) d\xi_0 \end{aligned}$$

$$\begin{aligned}
& - \frac{\beta^2}{\xi} \left[\frac{\xi_0}{(\xi - \xi_0)} h_r^{(n)}(\xi_0) \sqrt{\frac{1 - \xi_0}{\xi_0}} \exp\left(\frac{i\mu(\xi - \xi_0)}{(1+M)}\right) \right]_0^{\xi - \delta} \\
& + \frac{\beta^2}{\xi} \int_0^{\xi - \delta} \frac{\xi_0}{(\xi - \xi_0)} \frac{d}{d\xi_0} \left\{ h_r^{(n)}(\xi_0) \sqrt{\frac{1 - \xi_0}{\xi_0}} \exp\left(\frac{i\mu(\xi - \xi_0)}{(1+M)}\right) \right\} d\xi_0 \\
& = - \beta^2 \frac{(\xi - \delta)}{\xi \delta} h_r^{(n)}(\xi - \delta) \sqrt{\frac{1 - \xi + \delta}{\xi - \delta}} \exp\left(\frac{i\mu\delta}{(1+M)}\right) \\
& + \int_0^{\xi - \delta} \left[\frac{\beta^2 \xi_0}{\xi} \frac{d}{d\xi_0} \left\{ h_r^{(n)}(\xi_0) \sqrt{\frac{1 - \xi_0}{\xi_0}} \exp\left(\frac{i\mu(\xi - \xi_0)}{(1+M)}\right) \right\} \right. \\
& \quad \left. - \beta^2 \left\{ \frac{d}{d\xi} \left(h_r^{(n)}(\xi) \sqrt{\frac{1 - \xi}{\xi}} \right) - i\mu(1 - M) h_r^{(n)}(\xi) \sqrt{\frac{1 - \xi}{\xi}} \sqrt{\frac{\xi(1 - \xi)}{\xi_0(1 - \xi_0)}} \right\} \frac{d\xi_0}{(\xi - \xi_0)} \right. \\
& \quad \left. + \left[\beta^2 \frac{d}{d\xi} \left(h_r^{(n)}(\xi) \sqrt{\frac{1 - \xi}{\xi}} \right) - i\mu(1 - M) h_r^{(n)}(\xi) \sqrt{\frac{1 - \xi}{\xi}} \right] \int_0^{\xi - \delta} \sqrt{\frac{\xi(1 - \xi)}{\xi_0(1 - \xi_0)}} \frac{d\xi_0}{(\xi - \xi_0)} \right. \\
& \quad \left. - \left[- \frac{\beta^2}{\delta} h_r^{(n)}(\xi) \sqrt{\frac{1 - \xi}{\xi}} + \frac{\beta^2}{\xi} \frac{d}{d\xi} \left(h_r^{(n)}(\xi) \sqrt{\xi(1 - \xi)} \right) - i\mu(1 - M) h_r^{(n)}(\xi) \sqrt{\frac{1 - \xi}{\xi}} \right] \right. \\
& \quad \left. + \left[- \beta^2 \frac{d}{d\xi} \left(h_r^{(n)}(\xi) \sqrt{\frac{1 - \xi}{\xi}} \right) + i\mu(1 - M) h_r^{(n)}(\xi) \sqrt{\frac{1 - \xi}{\xi}} \right] \log\left(\frac{\delta}{4\xi(1 - \xi)}\right) \right. \\
& \quad \left. + \int_0^{\xi} \left[\frac{\beta^2 \xi_0}{\xi} \frac{d}{d\xi_0} \left\{ h_r^{(n)}(\xi_0) \sqrt{\frac{1 - \xi_0}{\xi_0}} \exp\left(\frac{i\mu(\xi - \xi_0)}{(1+M)}\right) \right\} \right. \right. \\
& \quad \left. \left. - \left\{ \beta^2 \frac{d}{d\xi} \left(h_r^{(n)}(\xi) \sqrt{\frac{1 - \xi}{\xi}} \right) \right. \right. \right. \\
& \quad \left. \left. \left. - i\mu(1 - M) h_r^{(n)}(\xi) \sqrt{\frac{1 - \xi}{\xi}} \sqrt{\frac{\xi(1 - \xi)}{\xi_0(1 - \xi_0)}} \right\} \frac{d\xi_0}{(\xi - \xi_0)} + o(\delta) \right. \right. \quad (B-32)
\end{aligned}$$

In order to get formula (B-32) we have used the formula

$$\int_0^{\xi-\delta} \sqrt{\frac{\xi(1-\xi)}{\xi_0(1-\xi_0)}} \frac{d\xi_0}{(\xi-\xi_0)} = -\log\left(\frac{\delta}{4\xi(1-\xi)}\right) + o(\delta) \quad (B-33)$$

which is obtained from the general integral formula

$$\int \sqrt{\frac{\xi(1-\xi)}{\xi_0(1-\xi_0)}} \frac{d\xi_0}{(\xi-\xi_0)} = \frac{1}{2} \log\left(\frac{\xi_0 + \xi - 2\xi_0\xi + 2\sqrt{\xi\xi_0(1-\xi)(1-\xi_0)}}{\xi_0 + \xi - 2\xi_0\xi - 2\sqrt{\xi\xi_0(1-\xi)(1-\xi_0)}}\right) \quad (B-34)$$

on putting in the appropriate integration limits. The validity of formula (B-34) can be verified by straightforward differentiation with respect to ξ_0 .

We also get from the general integral formula (B-34) the formula

$$\int_{\xi+\delta}^1 \sqrt{\frac{\xi(1-\xi)}{\xi_0(1-\xi_0)}} \frac{d\xi_0}{(\xi-\xi_0)} = \log\left(\frac{\delta}{4\xi(1-\xi)}\right) + o(\delta) \quad (B-35)$$

which we shall use presently.

Again

$$\begin{aligned} & -2(i\mu M) \int_0^{\xi-\delta} h_r^{(n)}(\xi_0) \sqrt{\frac{1-\xi_0}{\xi_0}} \exp\left(\frac{i\mu(\xi-\xi_0)}{(1+M)}\right) \frac{d\xi_0}{(\xi-\xi_0)} \\ & = -2(i\mu M) \int_0^{\xi-\delta} \left[h_r^{(n)}(\xi_0) \sqrt{\frac{1-\xi_0}{\xi_0}} \exp\left(\frac{i\mu(\xi-\xi_0)}{(1+M)}\right) - \frac{h_r^{(n)}(\xi)(1-\xi)}{\sqrt{\xi_0(1-\xi_0)}} \right] \frac{d\xi_0}{(\xi-\xi_0)} \\ & \quad - 2(i\mu M) h_r^{(n)}(\xi) \sqrt{\frac{1-\xi}{\xi}} \int_0^{\xi-\delta} \sqrt{\frac{\xi(1-\xi)}{\xi_0(1-\xi_0)}} \frac{d\xi_0}{(\xi-\xi_0)} \\ & = 2(i\mu M) h_r^{(n)}(\xi) \sqrt{\frac{1-\xi}{\xi}} \log\left(\frac{\delta}{4\xi(1-\xi)}\right) \\ & \quad - 2(i\mu M) \int_0^{\xi} \left[h_r^{(n)}(\xi_0) \sqrt{\frac{1-\xi_0}{\xi_0}} \exp\left(\frac{i\mu(\xi-\xi_0)}{(1+M)}\right) - \frac{h_r^{(n)}(\xi)(1-\xi)}{\sqrt{\xi_0(1-\xi_0)}} \right] \frac{d\xi_0}{(\xi-\xi_0)} + o(\delta) \end{aligned} \quad \dots\dots (B-36)$$

79125

and

$$\begin{aligned}
& \int_{\xi+\delta}^1 h_r^{(n)}(\xi_0) \sqrt{\frac{1-\xi_0}{\xi_0}} \exp\left(\frac{i\mu(\xi-\xi_0)}{(1-M)}\right) \frac{\beta^2}{(\xi-\xi_0)^2} d\xi_0 \\
&= \frac{\beta^2}{\xi} \int_{\xi+\delta}^1 h_r^{(n)}(\xi_0) \sqrt{\frac{1-\xi_0}{\xi_0}} \exp\left(\frac{i\mu(\xi-\xi_0)}{(1-M)}\right) \frac{d}{d\xi_0} \left(\frac{\xi_0}{\xi-\xi_0}\right) d\xi_0 \\
&= \frac{\beta^2}{\xi} \left[\frac{\xi_0}{(\xi-\xi_0)} h_r^{(n)}(\xi_0) \sqrt{\frac{1-\xi_0}{\xi_0}} \exp\left(\frac{i\mu(\xi-\xi_0)}{(1-M)}\right) \right]_{\xi+\delta}^1 \\
&= \frac{\beta^2}{\xi} \int_{\xi+\delta}^1 \frac{\xi_0}{(\xi-\xi_0)} \frac{d}{d\xi_0} \left\{ h_r^{(n)}(\xi_0) \sqrt{\frac{1-\xi_0}{\xi_0}} \exp\left(\frac{i\mu(\xi-\xi_0)}{(1-M)}\right) \right\} d\xi_0 \\
&= \beta^2 \frac{(\xi+\delta)}{\xi\delta} h_r^{(n)}(\xi+\delta) \sqrt{\frac{1-\xi-\delta}{\xi+\delta}} \exp\left(-\frac{i\mu\delta}{(1-M)}\right) \\
&= \int_{\xi+\delta}^1 \left[\frac{\beta^2 \xi_0}{\xi} \frac{d}{d\xi_0} \left\{ h_r^{(n)}(\xi_0) \sqrt{\frac{1-\xi_0}{\xi_0}} \exp\left(\frac{i\mu(\xi-\xi_0)}{(1-M)}\right) \right\} \right. \\
&\quad \left. - \left\{ \beta^2 \frac{d}{d\xi} \left(h_r^{(n)}(\xi) \sqrt{\frac{1-\xi}{\xi}} \right) - i\mu(1+M) h_r^{(n)}(\xi) \sqrt{\frac{1-\xi}{\xi}} \right\} \sqrt{\frac{\xi(1-\xi)}{\xi_0(1-\xi_0)}} \right] \frac{d\xi_0}{(\xi-\xi_0)} \\
&= \left[\beta^2 \frac{d}{d\xi} \left(h_r^{(n)}(\xi) \sqrt{\frac{1-\xi}{\xi}} \right) - i\mu(1+M) h_r^{(n)}(\xi) \sqrt{\frac{1-\xi}{\xi}} \right] \int_{\xi+\delta}^1 \sqrt{\frac{\xi(1-\xi)}{\xi_0(1-\xi_0)}} \frac{d\xi_0}{(\xi-\xi_0)} \\
&= \left[\frac{\beta^2}{\delta} h_r^{(n)}(\xi) \sqrt{\frac{1-\xi}{\xi}} + \frac{\beta^2}{\xi} \frac{d}{d\xi} \left(h_r^{(n)}(\xi) \sqrt{\xi(1-\xi)} \right) - i\mu(1+M) h_r^{(n)}(\xi) \sqrt{\frac{1-\xi}{\xi}} \right] \\
&+ \left[-\beta^2 \frac{d}{d\xi} \left(h_r^{(n)}(\xi) \sqrt{\frac{1-\xi}{\xi}} \right) + i\mu(1+M) h_r^{(n)}(\xi) \sqrt{\frac{1-\xi}{\xi}} \right] \log\left(\frac{\delta}{4\xi(1-\xi)}\right) \\
&= \int_{\xi+\delta}^1 \left[\frac{\beta^2 \xi_0}{\xi} \frac{d}{d\xi_0} \left\{ h_r^{(n)}(\xi_0) \sqrt{\frac{1-\xi_0}{\xi_0}} \exp\left(\frac{i\mu(\xi-\xi_0)}{(1-M)}\right) \right\} \right. \\
&\quad \left. - \left\{ \beta^2 \frac{d}{d\xi} \left(h_r^{(n)}(\xi) \sqrt{\frac{1-\xi}{\xi}} \right) \right. \right. \\
&\quad \left. \left. - i\mu(1+M) h_r^{(n)}(\xi) \sqrt{\frac{1-\xi}{\xi}} \right\} \sqrt{\frac{\xi(1-\xi)}{\xi_0(1-\xi_0)}} \right] \frac{d\xi_0}{(\xi-\xi_0)} + o(\delta) \quad (B-37)
\end{aligned}$$

On substituting the integrals from formulae (B-32), (B-36) and (B-37) into the right-hand side of (B-31) we get

$$\begin{aligned}
 & \lim_{|\sigma| \rightarrow 0} \left\{ \int_0^1 h_r^{(n)}(\xi_0) A(\xi - \xi_0, \sigma; \mu, M) \sqrt{\frac{1 - \xi_0}{\xi_0}} d\xi_0 \right. \\
 & \quad \left. + \log(\sigma^2) \left[\beta^2 \frac{d}{d\xi} \left(h_r^{(n)}(\xi) \sqrt{\frac{1 - \xi}{\xi}} \right) - i\mu(1 + M) h_r^{(n)}(\xi) \sqrt{\frac{1 - \xi}{\xi}} \right] \right\} \\
 & = \frac{2\beta^2}{\xi} h_r^{(n)}(\xi) \sqrt{\frac{1 - \xi}{\xi}} \\
 & \quad + 2 \log\left(\frac{8\xi(1 - \xi)}{\beta}\right) \left[\beta^2 \frac{d}{d\xi} \left(h_r^{(n)}(\xi) \sqrt{\frac{1 - \xi}{\xi}} \right) - i\mu(1 + M) h_r^{(n)}(\xi) \sqrt{\frac{1 - \xi}{\xi}} \right] \\
 & \quad + \int_0^\xi \left[\frac{\beta^2 \xi_0}{\xi} \frac{d}{d\xi_0} \left\{ h_r^{(n)}(\xi_0) \sqrt{\frac{1 - \xi_0}{\xi_0}} \exp\left(\frac{i\mu(\xi - \xi_0)}{(1 + M)}\right) \right\} \right. \\
 & \quad \left. - \left\{ \beta^2 \frac{d}{d\xi} \left(h_r^{(n)}(\xi) \sqrt{\frac{1 - \xi}{\xi}} \right) - i\mu(1 - M) h_r^{(n)}(\xi) \sqrt{\frac{1 - \xi}{\xi}} \right\} \sqrt{\frac{\xi(1 - \xi)}{\xi_0(1 - \xi_0)}} \frac{d\xi_0}{(\xi - \xi_0)} \right. \\
 & \quad \left. - \int_\xi^1 \left[\frac{\beta^2 \xi_0}{\xi} \frac{d}{d\xi_0} \left\{ h_r^{(n)}(\xi_0) \sqrt{\frac{1 - \xi_0}{\xi_0}} \exp\left(\frac{i\mu(\xi - \xi_0)}{(1 - M)}\right) \right\} \right. \right. \\
 & \quad \left. \left. - \left\{ \beta^2 \frac{d}{d\xi} \left(h_r^{(n)}(\xi) \sqrt{\frac{1 - \xi}{\xi}} \right) - i\mu(1 + M) h_r^{(n)}(\xi) \sqrt{\frac{1 - \xi}{\xi}} \right\} \sqrt{\frac{\xi(1 - \xi)}{\xi_0(1 - \xi_0)}} \frac{d\xi_0}{(\xi - \xi_0)} \right. \right. \\
 & \quad \left. \left. - 2(i\mu M) \int_0^\xi \left[h_r^{(n)}(\xi_0) \sqrt{\frac{1 - \xi_0}{\xi_0}} \exp\left(\frac{i\mu(\xi - \xi_0)}{(1 + M)}\right) - \frac{h_r^{(n)}(\xi)(1 - \xi)}{\sqrt{\xi_0(1 - \xi_0)}} \right] \frac{d\xi_0}{(\xi - \xi_0)} \right. \right. \\
 & \quad \left. \left. \dots \dots (B-38) \right. \right.
 \end{aligned}$$

A contribution of $O(\delta)$ does not appear on the right-hand side of (B-38) for the complete expression is independent of δ .

Let us define the function $k_r^{(n)}(\xi_0)$ by means of the formula

$$k_r^{(n)}(\xi_0) = \int_0^{\xi_0} h_r^{(n)}(u) \sqrt{\frac{1-u}{u}} du, \quad 0 < \xi_0 < 1. \quad (B-39)$$

On expanding $k_r^{(n)}(\xi_0)$ by Taylor's series expansion about $\xi_0 = \xi$ we get

$$k_r^{(n)}(\xi_0) = k_r^{(n)}(\xi) + (\xi_0 - \xi) h_r^{(n)}(\xi) \sqrt{\frac{1-\xi}{\xi}} + (\xi_0 - \xi)^2 O(1) \quad (B-40)$$

as $\xi_0 \rightarrow \xi$ if $0 < \xi < 1$.

Then, when $0 < \xi < 1$, we have

$$\begin{aligned} & \int_0^1 h_r^{(n)}(\xi_0) B(\xi - \xi_0, \sigma; \mu, M) \sqrt{\frac{1-\xi_0}{\xi_0}} d\xi_0 \\ &= \frac{i\mu}{(1+M)} \int_0^1 h_r^{(n)}(\xi_0) \sqrt{\frac{1-\xi_0}{\xi_0}} d\xi_0 \int_{-\infty}^{\xi-\xi_0} \left[\frac{\beta^2 u}{(u^2 + \beta^2 \sigma^2)^{\frac{3}{2}}} + \frac{i\mu M}{(u^2 + \beta^2 \sigma^2)^{\frac{1}{2}}} \left(1 + \frac{u}{(u^2 + \beta^2 \sigma^2)^{\frac{1}{2}}} \right) \right] \\ & \quad \times \exp\left\{ \frac{i\mu}{\beta^2} (u - M(u^2 + \beta^2 \sigma^2)^{\frac{1}{2}}) \right\} du \\ &= \frac{i\mu}{(1+M)} \left[k_r^{(n)}(\xi_0) \int_{-\infty}^{\xi-\xi_0} \left[\frac{\beta^2 u}{(u^2 + \beta^2 \sigma^2)^{\frac{3}{2}}} + \frac{i\mu M}{(u^2 + \beta^2 \sigma^2)^{\frac{1}{2}}} \left(1 + \frac{u}{(u^2 + \beta^2 \sigma^2)^{\frac{1}{2}}} \right) \right] \right. \\ & \quad \left. \times \exp\left\{ \frac{i\mu}{\beta^2} (u - M(u^2 + \beta^2 \sigma^2)^{\frac{1}{2}}) \right\} du \right]_{\xi_0=0}^1 \\ &+ \frac{i\mu}{(1+M)} \int_0^1 k_r^{(n)}(\xi_0) \left[\frac{\beta^2 (\xi - \xi_0)}{\{(\xi - \xi_0)^2 + \beta^2 \sigma^2\}^{\frac{3}{2}}} + \frac{i\mu M}{\{(\xi - \xi_0)^2 + \beta^2 \sigma^2\}^{\frac{1}{2}}} \left(1 + \frac{(\xi - \xi_0)}{\{(\xi - \xi_0)^2 + \beta^2 \sigma^2\}^{\frac{1}{2}}} \right) \right] \\ & \quad \times \exp\left\{ \frac{i\mu}{\beta^2} (\xi - \xi_0 - M((\xi - \xi_0)^2 + \beta^2 \sigma^2)^{\frac{1}{2}}) \right\} d\xi_0 \end{aligned}$$

$$\begin{aligned}
 &= \frac{i\mu}{(1+M)} k_r^{(n)}(1) \int_{-\infty}^{-(1-\xi)} \left[\frac{\beta^2 u}{(u^2 + \beta^2 \sigma^2)^{\frac{3}{2}}} + \frac{i\mu M}{(u^2 + \beta^2 \sigma^2)^{\frac{1}{2}}} \left(1 + \frac{u}{(u^2 + \beta^2 \sigma^2)^{\frac{1}{2}}} \right) \right] \\
 &\quad \times \exp\left\{ \frac{i\mu}{\beta^2} (u - M(u^2 + \beta^2 \sigma^2)^{\frac{1}{2}}) \right\} du \\
 &+ \frac{i\mu}{(1+M)} \int_0^1 k_r^{(n)}(\xi_0) \left[\frac{\beta^2 (\xi - \xi_0)}{\{(\xi - \xi_0)^2 + \beta^2 \sigma^2\}^{\frac{3}{2}}} + \frac{i\mu M}{\{(\xi - \xi_0)^2 + \beta^2 \sigma^2\}^{\frac{1}{2}}} \left(1 + \frac{(\xi - \xi_0)}{\{(\xi - \xi_0)^2 + \beta^2 \sigma^2\}^{\frac{1}{2}}} \right) \right] \\
 &\quad \times \exp\left\{ \frac{i\mu}{\beta^2} \left((\xi - \xi_0) - M \{(\xi - \xi_0)^2 + \beta^2 \sigma^2\}^{\frac{1}{2}} \right) \right\} d\xi_0 .
 \end{aligned}$$

..... (B-41)

Now, with $\xi < 1$,

$$\begin{aligned}
 &\lim_{|\sigma| \rightarrow 0} \left\{ \frac{i\mu}{(1+M)} k_r^{(n)}(1) \int_{-\infty}^{-(1-\xi)} \left[\frac{\beta^2 u}{(u^2 + \beta^2 \sigma^2)^{\frac{3}{2}}} + \frac{i\mu M}{(u^2 + \beta^2 \sigma^2)^{\frac{1}{2}}} \left(1 + \frac{u}{(u^2 + \beta^2 \sigma^2)^{\frac{1}{2}}} \right) \right] \right. \\
 &\quad \left. \times \exp\left\{ \frac{i\mu}{\beta^2} (u - M(u^2 + \beta^2 \sigma^2)^{\frac{1}{2}}) \right\} du \right\} \\
 &= -i\mu(1-M) k_r^{(n)}(1) \int_{-\infty}^{-(1-\xi)} \exp\left(\frac{i\mu u}{(1-M)} \right) \frac{du}{u^2} \\
 &= -i\mu(1-M) k_r^{(n)}(1) \int_{1-\xi}^{\infty} \exp\left(-\frac{i\mu u}{(1-M)} \right) \frac{du}{u^2} \\
 &= -i\mu(1-M) k_r^{(n)}(1) \left[\frac{1}{(1-\xi)} \exp\left(-\frac{i\mu(1-\xi)}{(1-M)} \right) - \frac{i\mu}{(1-M)} \int_{\frac{\mu(1-\xi)}{(1-M)}}^{\infty} e^{-i\lambda \frac{d\lambda}{\lambda}} \right] \\
 &= k_r^{(n)}(1) \left[-i\mu \frac{(1-M)}{(1-\xi)} \exp\left(-\frac{i\mu(1-\xi)}{(1-M)} \right) + (i\mu)^2 \int_{\frac{\mu(1-\xi)}{(1-M)}}^{\infty} e^{-i\lambda \frac{d\lambda}{\lambda}} \right] . \quad (B-42)
 \end{aligned}$$

Also

$$\begin{aligned}
& \frac{i\mu}{(1+M)} \int_0^1 k_r^{(n)}(\xi_0) \left[\frac{\beta^2(\xi - \xi_0)}{\{(\xi - \xi_0)^2 + \beta^2\sigma^2\}^{\frac{1}{2}}} \right. \\
& \quad \left. + \frac{i\mu M}{\{(\xi - \xi_0)^2 + \beta^2\sigma^2\}^{\frac{1}{2}}} \left(1 + \frac{(\xi - \xi_0)}{\{(\xi - \xi_0)^2 + \beta^2\sigma^2\}^{\frac{1}{2}}} \right) \right] \\
& \quad \times \exp\left\{ \frac{i\mu}{\beta^2} \left((\xi - \xi_0) - M \left((\xi - \xi_0)^2 + \beta^2\sigma^2 \right)^{\frac{1}{2}} \right) \right\} d\xi_0 \\
& = \frac{i\mu}{(1+M)} \left(\int_0^{\xi-\delta} + \int_{\xi+\delta}^1 \right) k_r^{(n)}(\xi_0) \left[\frac{\beta^2(\xi - \xi_0)}{\{(\xi - \xi_0)^2 + \beta^2\sigma^2\}^{\frac{1}{2}}} \right. \\
& \quad \left. + \frac{i\mu M}{\{(\xi - \xi_0)^2 + \beta^2\sigma^2\}^{\frac{1}{2}}} \left(1 + \frac{(\xi - \xi_0)}{\{(\xi - \xi_0)^2 + \beta^2\sigma^2\}^{\frac{1}{2}}} \right) \right] \\
& \quad \times \exp\left\{ \frac{i\mu}{\beta^2} \left((\xi - \xi_0) - M \left((\xi - \xi_0)^2 + \beta^2\sigma^2 \right)^{\frac{1}{2}} \right) \right\} d\xi_0 \\
& + \frac{i\mu}{(1+M)} \int_{\xi-\delta}^{\xi+\delta} \left\{ k_r^{(n)}(\xi_0) - k_r^{(n)}(\xi) + (\xi - \xi_0) h_r^{(n)}(\xi) \sqrt{\frac{1-\xi}{\xi}} \right\} \\
& \quad \times \frac{\beta^2(\xi - \xi_0)}{\{(\xi - \xi_0)^2 + \beta^2\sigma^2\}^{\frac{1}{2}}} \exp\left\{ \frac{i\mu}{\beta^2} \left((\xi - \xi_0) - M \left((\xi - \xi_0)^2 + \beta^2\sigma^2 \right)^{\frac{1}{2}} \right) \right\} d\xi_0 \\
& + \frac{i\mu}{(1+M)} k_r^{(n)}(\xi) \int_{\xi-\delta}^{\xi+\delta} \frac{\beta^2(\xi - \xi_0)}{\{(\xi - \xi_0)^2 + \beta^2\sigma^2\}^{\frac{1}{2}}} \left[\exp\left\{ \frac{i\mu}{\beta^2} \left((\xi - \xi_0) - M \left((\xi - \xi_0)^2 + \beta^2\sigma^2 \right)^{\frac{1}{2}} \right) \right\} - 1 \right. \\
& \quad \left. - \frac{i\mu}{\beta^2} \left((\xi - \xi_0) - M \left((\xi - \xi_0)^2 + \beta^2\sigma^2 \right)^{\frac{1}{2}} \right) \right] d\xi_0
\end{aligned}$$

$$\begin{aligned}
& - \frac{i\mu}{(1+M)} h_r^{(n)}(\xi) \sqrt{\frac{1-\xi}{\xi}} \int_{\xi-\delta}^{\xi+\delta} \frac{\beta^2 (\xi - \xi_0)^2}{\{(\xi - \xi_0)^2 + \beta^2 \sigma^2\}^{\frac{3}{2}}} \\
& \quad \times \left[\exp\left\{ \frac{i\mu}{\beta^2} ((\xi - \xi_0) - M((\xi - \xi_0)^2 + \beta^2 \sigma^2)^{\frac{1}{2}}) \right\} - 1 \right] d\xi_0 \\
& + \frac{i\mu}{(1+M)} \int_{\xi-\delta}^{\xi+\delta} \left\{ k_r^{(n)}(\xi_0) - k_r^{(n)}(\xi) \right\} \frac{(i\mu M)}{\{(\xi - \xi_0)^2 + \beta^2 \sigma^2\}^{\frac{3}{2}}} \left(1 + \frac{(\xi - \xi_0)}{\{(\xi - \xi_0)^2 + \beta^2 \sigma^2\}^{\frac{1}{2}}} \right) \\
& \quad \times \exp\left\{ \frac{i\mu}{\beta^2} ((\xi - \xi_0) - M((\xi - \xi_0)^2 + \beta^2 \sigma^2)^{\frac{1}{2}}) \right\} d\xi_0 \\
& + \frac{i\mu}{(1+M)} k_r^{(n)}(\xi) \int_{\xi-\delta}^{\xi+\delta} \frac{i\mu M}{\{(\xi - \xi_0)^2 + \beta^2 \sigma^2\}^{\frac{3}{2}}} \left(1 + \frac{(\xi - \xi_0)}{\{(\xi - \xi_0)^2 + \beta^2 \sigma^2\}^{\frac{1}{2}}} \right) \\
& \quad \times \left[\exp\left\{ \frac{i\mu}{\beta^2} ((\xi - \xi_0) - M((\xi - \xi_0)^2 + \beta^2 \sigma^2)^{\frac{1}{2}}) \right\} - 1 \right] d\xi_0 \\
& + i\mu(1-M) k_r^{(n)}(\xi) \int_{\xi-\delta}^{\xi+\delta} \frac{(\xi - \xi_0)}{\{(\xi - \xi_0)^2 + \beta^2 \sigma^2\}^{\frac{3}{2}}} \\
& \quad \times \left[1 + \frac{i\mu}{\beta^2} ((\xi - \xi_0) - M((\xi - \xi_0)^2 + \beta^2 \sigma^2)^{\frac{1}{2}}) \right] d\xi_0 \\
& - i\mu(1-M) h_r^{(n)}(\xi) \sqrt{\frac{1-\xi}{\xi}} \int_{\xi-\delta}^{\xi+\delta} \frac{(\xi - \xi_0)^2}{\{(\xi - \xi_0)^2 + \beta^2 \sigma^2\}^{\frac{3}{2}}} d\xi_0 \\
& + \frac{(i\mu)^2 M}{(1+M)} k_r^{(n)}(\xi) \int_{\xi-\delta}^{\xi+\delta} \frac{1}{\{(\xi - \xi_0)^2 + \beta^2 \sigma^2\}^{\frac{3}{2}}} \left(1 + \frac{(\xi - \xi_0)}{\{(\xi - \xi_0)^2 + \beta^2 \sigma^2\}^{\frac{1}{2}}} \right) d\xi_0
\end{aligned}$$

$$\begin{aligned}
&= \frac{i\mu}{(1+M)} \left(\int_0^{\xi-\delta} + \int_{\xi+\delta}^1 \right) k_r^{(n)}(\xi_0) \left[\frac{\beta^2(\xi-\xi_0)}{\{(\xi-\xi_0)^2 + \beta^2\sigma^2\}^{\frac{1}{2}}} \right. \\
&\quad \left. + \frac{i\mu M}{\{(\xi-\xi_0)^2 + \beta^2\sigma^2\}^{\frac{1}{2}}} \left(1 + \frac{(\xi-\xi_0)}{\{(\xi-\xi_0)^2 + \beta^2\sigma^2\}^{\frac{1}{2}}} \right) \right] \\
&\quad \times \exp\left\{ \frac{i\mu}{\beta^2} \left((\xi-\xi_0) - M \left((\xi-\xi_0)^2 + \beta^2\sigma^2 \right)^{\frac{1}{2}} \right) \right\} d\xi_0 \\
&+ 2 \left[-i\mu(1-M)h_r^{(n)}(\xi) \sqrt{\frac{1-\xi}{\xi}} + \frac{(i\mu)^2}{(1+M)} k_r^{(n)}(\xi) \right] \left[\log\left(\frac{\sqrt{\delta^2 + \beta^2\sigma^2} + \delta}{\beta|\sigma|} \right) - \frac{\delta}{\sqrt{\delta^2 + \beta^2\sigma^2}} \right] \\
&+ 2 \frac{(i\mu)^2 M}{(1+M)} k_r^{(n)}(\xi) \log\left(\frac{\sqrt{\delta^2 + \beta^2\sigma^2} + \delta}{\beta|\sigma|} \right) + 0(\delta) \quad . \quad (B-43)
\end{aligned}$$

where δ is an arbitrary positive number which is such that inequalities (B-30) are true.

We get directly from formula (B-43)

$$\begin{aligned}
\lim_{|\sigma| \rightarrow 0} &\left\{ \frac{i\mu}{(1+M)} \int_0^1 k_r^{(n)}(\xi_0) \left[\frac{\beta^2(\xi-\xi_0)}{\{(\xi-\xi_0)^2 + \beta^2\sigma^2\}^{\frac{1}{2}}} \right. \right. \\
&\quad \left. \left. + \frac{i\mu M}{\{(\xi-\xi_0)^2 + \beta^2\sigma^2\}^{\frac{1}{2}}} \left(1 + \frac{(\xi-\xi_0)}{\{(\xi-\xi_0)^2 + \beta^2\sigma^2\}^{\frac{1}{2}}} \right) \right] \right. \\
&\quad \left. \times \exp\left\{ \frac{i\mu}{\beta^2} \left((\xi-\xi_0) - M \left((\xi-\xi_0)^2 + \beta^2\sigma^2 \right)^{\frac{1}{2}} \right) \right\} d\xi_0 \right. \\
&\quad \left. + \log(\sigma^2) \left[-i\mu(1-M)h_r^{(n)}(\xi) \sqrt{\frac{1-\xi}{\xi}} + (i\mu)^2 k_r^{(n)}(\xi) \right] \right\}
\end{aligned}$$

$$\begin{aligned}
&= \frac{i\mu}{(1+M)} \int_0^{\xi-\delta} k_r^{(n)}(\xi_0) \left[\frac{\beta^2}{(\xi-\xi_0)^2} + \frac{2i\mu M}{(\xi-\xi_0)} \right] \exp\left(\frac{i\mu(\xi-\xi_0)}{(1+M)}\right) d\xi_0 \\
&\quad - \frac{i\mu}{(1+M)} \int_{\xi+\delta}^1 k_r^{(n)}(\xi_0) \frac{\beta^2}{(\xi-\xi_0)^2} \exp\left(\frac{i\mu(\xi-\xi_0)}{(1-M)}\right) d\xi_0 \\
&\quad + 2 \left[-i\mu(1-M)h_r^{(n)}(\xi) \sqrt{\frac{1-\xi}{\xi}} + \frac{(i\mu)^2}{(1+M)} k_r^{(n)}(\xi) \right] \left[\log\left(\frac{2\delta}{\beta}\right) - 1 \right] \\
&\quad + 2 \frac{(i\mu)^2 M}{(1+M)} k_r^{(n)}(\xi) \log\left(\frac{2\delta}{\beta}\right) + o(\delta) \quad . \quad (B-44)
\end{aligned}$$

Then from formula (B-41), on using the results (B-42) and (B-44) we get

$$\begin{aligned}
&\lim_{|\sigma| \rightarrow 0} \left\{ \int_0^1 h_r^{(n)}(\xi_0) B(\xi-\xi_0, \sigma; \mu, M) \sqrt{\frac{1-\xi_0}{\xi_0}} d\xi_0 \right. \\
&\quad \left. + \log(\sigma^2) \left[-i\mu(1-M)h_r^{(n)}(\xi) \sqrt{\frac{1-\xi}{\xi}} + (i\mu)^2 k_r^{(n)}(\xi) \right] \right\} \\
&= k_r^{(n)}(1) \left[-i\mu \frac{(1-M)}{(1-\xi)} \exp\left(-\frac{i\mu(1-\xi)}{(1-M)}\right) + (i\mu)^2 \int_{\frac{\mu(1-\xi)}{(1-M)}}^{\infty} e^{-i\lambda} \frac{d\lambda}{\lambda} \right] \\
&\quad + \frac{i\mu}{(1+M)} \int_0^{\xi-\delta} k_r^{(n)}(\xi_0) \left[\frac{\beta^2}{(\xi-\xi_0)^2} + \frac{2i\mu M}{(\xi-\xi_0)} \right] \exp\left(\frac{i\mu(\xi-\xi_0)}{(1+M)}\right) d\xi_0 \\
&\quad - i\mu(1-M) \int_{\xi+\delta}^1 \frac{k_r^{(n)}(\xi_0)}{(\xi-\xi_0)^2} \exp\left(\frac{i\mu(\xi-\xi_0)}{(1-M)}\right) d\xi_0 \\
&\quad + 2 \left[-i\mu(1-M)h_r^{(n)}(\xi) \sqrt{\frac{1-\xi}{\xi}} + \frac{(i\mu)^2}{(1+M)} k_r^{(n)}(\xi) \right] \left[\log\left(\frac{2\delta}{\beta}\right) - 1 \right] \\
&\quad + 2 \frac{(i\mu)^2 M}{(1+M)} k_r^{(n)}(\xi) \log\left(\frac{2\delta}{\beta}\right) + o(\delta) \quad . \quad (B-45)
\end{aligned}$$

Now

$$\begin{aligned}
& i\mu(1-M) \int_0^{\xi-\delta} \frac{k_r^{(n)}(\xi_0)}{(\xi-\xi_0)^2} \exp\left(\frac{i\mu(\xi-\xi_0)}{(1+M)}\right) d\xi_0 \\
&= i\mu(1-M) \int_0^{\xi-\delta} k_r^{(n)}(\xi_0) \exp\left(\frac{i\mu(\xi-\xi_0)}{(1+M)}\right) \frac{d}{d\xi_0} \left(\frac{1}{\xi-\xi_0}\right) d\xi_0 \\
&= i\mu(1-M) \left[\frac{k_r^{(n)}(\xi_0)}{(\xi-\xi_0)} \exp\left(\frac{i\mu(\xi-\xi_0)}{(1+M)}\right) \right]_0^{\xi-\delta} \\
&= i\mu(1-M) \int_0^{\xi-\delta} \frac{d}{d\xi_0} \left\{ k_r^{(n)}(\xi_0) \exp\left(\frac{i\mu(\xi-\xi_0)}{(1+M)}\right) \right\} \frac{d\xi_0}{(\xi-\xi_0)} \\
&= i\mu(1-M) \frac{k_r^{(n)}(\xi-\delta)}{\delta} \exp\left(\frac{i\mu\delta}{(1+M)}\right) \\
&= i\mu(1-M) \int_0^{\xi-\delta} \left[\frac{d}{d\xi_0} \left\{ k_r^{(n)}(\xi_0) \exp\left(\frac{i\mu(\xi-\xi_0)}{(1+M)}\right) \right\} \right. \\
&\quad \left. - \left\{ h_r^{(n)}(\xi) \sqrt{\frac{1-\xi}{\xi}} - \frac{i\mu}{(1+M)} k_r^{(n)}(\xi) \right\} \sqrt{\frac{\xi(1-\xi)}{\xi_0(1-\xi_0)}} \right] \frac{d\xi_0}{(\xi-\xi_0)} \\
&+ \left[-i\mu(1-M) h_r^{(n)}(\xi) \sqrt{\frac{1-\xi}{\xi}} + (i\mu)^2 \frac{(1-M)}{(1+M)} k_r^{(n)}(\xi) \right] \int_0^{\xi-\delta} \sqrt{\frac{\xi(1-\xi)}{\xi_0(1-\xi_0)}} \frac{d\xi_0}{(\xi-\xi_0)} \\
&= \left[i\mu(1-M) \frac{k_r^{(n)}(\xi)}{\delta} - i\mu(1-M) h_r^{(n)}(\xi) \sqrt{\frac{1-\xi}{\xi}} + (i\mu)^2 \frac{(1-M)}{(1+M)} k_r^{(n)}(\xi) \right] \\
&+ \left[i\mu(1-M) h_r^{(n)}(\xi) \sqrt{\frac{1-\xi}{\xi}} - (i\mu)^2 \frac{(1-M)}{(1+M)} k_r^{(n)}(\xi) \right] \log\left(\frac{\delta}{4\xi(1-\xi)}\right) \\
&- i\mu(1-M) \int_0^{\xi} \left[\frac{d}{d\xi_0} \left\{ k_r^{(n)}(\xi_0) \exp\left(\frac{i\mu(\xi-\xi_0)}{(1+M)}\right) \right\} \right. \\
&\quad \left. - \left\{ h_r^{(n)}(\xi) \sqrt{\frac{1-\xi}{\xi}} - \frac{i\mu}{(1+M)} k_r^{(n)}(\xi) \right\} \sqrt{\frac{\xi(1-\xi)}{\xi_0(1-\xi_0)}} \right] \frac{d\xi_0}{(\xi-\xi_0)} \\
&+ O(\delta) .
\end{aligned}$$

Again

$$\begin{aligned}
& 2 \frac{(i\mu)^2 M}{(1+M)} \int_0^{\xi-\delta} k_r^{(n)}(\xi_0) \exp\left(\frac{i\mu(\xi-\xi_0)}{(1+M)}\right) \frac{d\xi_0}{(\xi-\xi_0)} \\
& - 2 \frac{(i\mu)^2 M}{(1+M)} \int_0^{\xi-\delta} \left[k_r^{(n)}(\xi_0) \exp\left(\frac{i\mu(\xi-\xi_0)}{(1+M)}\right) - k_r^{(n)}(\xi) \sqrt{\frac{\xi(1-\xi)}{\xi_0(1-\xi_0)}} \right] \frac{d\xi_0}{(\xi-\xi_0)} \\
& + 2 \frac{(i\mu)^2 M}{(1+M)} k_r^{(n)}(\xi) \int_0^{\xi-\delta} \sqrt{\frac{\xi(1-\xi)}{\xi_0(1-\xi_0)}} \frac{d\xi_0}{(\xi-\xi_0)} \\
& = - 2 \frac{(i\mu)^2 M}{(1+M)} k_r^{(n)}(\xi) \log\left(\frac{\delta}{4\xi(1-\xi)}\right) \\
& + 2 \frac{(i\mu)^2 M}{(1+M)} \int_0^{\xi} \left[k_r^{(n)}(\xi_0) \exp\left(\frac{i\mu(\xi-\xi_0)}{(1+M)}\right) - k_r^{(n)}(\xi) \sqrt{\frac{\xi(1-\xi)}{\xi_0(1-\xi_0)}} \right] \frac{d\xi_0}{(\xi-\xi_0)} \\
& + 0(\delta)
\end{aligned} \tag{B-47}$$

and

$$\begin{aligned}
& - i\mu(1-M) \int_{\xi+\delta}^1 \frac{k_r^{(n)}(\xi_0)}{(\xi-\xi_0)^2} \exp\left(\frac{i\mu(\xi-\xi_0)}{(1-M)}\right) d\xi_0 \\
& = - i\mu(1-M) \int_{\xi+\delta}^1 k_r^{(n)}(\xi_0) \exp\left(\frac{i\mu(\xi-\xi_0)}{(1-M)}\right) \frac{d}{d\xi_0} \left(\frac{1}{\xi-\xi_0}\right) d\xi_0 \\
& = - i\mu(1-M) \left[\frac{k_r^{(n)}(\xi_0)}{(\xi-\xi_0)} \exp\left(\frac{i\mu(\xi-\xi_0)}{(1-M)}\right) \right]_{\xi+\delta}^1 \\
& + i\mu(1-M) \int_{\xi+\delta}^1 \frac{d}{d\xi_0} \left\{ k_r^{(n)}(\xi_0) \exp\left(\frac{i\mu(\xi-\xi_0)}{(1-M)}\right) \right\} \frac{d\xi_0}{(\xi-\xi_0)}
\end{aligned}$$

$$\begin{aligned}
& - i\mu(1-M) \frac{k_r^{(n)}(\xi + \delta)}{\delta} \exp\left(-\frac{i\mu\delta}{(1-M)}\right) \\
& + i\mu(1-M) \frac{k_r^{(n)}(1)}{(1-\xi)} \exp\left(-\frac{i\mu(1-\xi)}{(1-M)}\right) \\
& + i\mu(1-M) \int_{\xi+\delta}^1 \left[\frac{d}{d\xi_0} \left\{ k_r^{(n)}(\xi_0) \exp\left(\frac{i\mu(\xi-\xi_0)}{(1-M)}\right) \right\} \right. \\
& \quad \left. - \left\{ h_r^{(n)}(\xi) \sqrt{\frac{1-\xi}{\xi}} - \frac{i\mu}{(1-M)} k_r^{(n)}(\xi) \right\} \sqrt{\frac{\xi(1-\xi)}{\xi_0(1-\xi_0)}} \right] \frac{d\xi_0}{(\xi-\xi_0)} \\
& + \left[i\mu(1-M) h_r^{(n)}(\xi) \sqrt{\frac{1-\xi}{\xi}} - (i\mu)^2 k_r^{(n)}(\xi) \right] \int_{\xi+\delta}^1 \sqrt{\frac{\xi(1-\xi)}{\xi_0(1-\xi_0)}} \frac{d\xi_0}{(\xi-\xi_0)} \\
& - \left[-i\mu(1-M) \frac{k_r^{(n)}(\xi)}{\delta} - i\mu(1-M) h_r^{(n)}(\xi) \sqrt{\frac{1-\xi}{\xi}} + (i\mu)^2 k_r^{(n)}(\xi) \right] \\
& + \left[i\mu(1-M) h_r^{(n)}(\xi) \sqrt{\frac{1-\xi}{\xi}} - (i\mu)^2 k_r^{(n)}(\xi) \right] \log\left(\frac{\delta}{4\xi(1-\xi)}\right) \\
& + i\mu(1-M) \frac{k_r^{(n)}(1)}{(1-\xi)} \exp\left(-\frac{i\mu(1-\xi)}{(1-M)}\right) \\
& + i\mu(1-M) \int_{\xi}^1 \left[\frac{d}{d\xi_0} \left\{ k_r^{(n)}(\xi_0) \exp\left(\frac{i\mu(\xi-\xi_0)}{(1-M)}\right) \right\} \right. \\
& \quad \left. - \left\{ h_r^{(n)}(\xi) \sqrt{\frac{1-\xi}{\xi}} - \frac{i\mu}{(1-M)} k_r^{(n)}(\xi) \right\} \sqrt{\frac{\xi(1-\xi)}{\xi_0(1-\xi_0)}} \right] \frac{d\xi_0}{(\xi-\xi_0)} \\
& + O(\delta)
\end{aligned}$$

(B-48)

On substituting the integrals from formulae (B-46), (B-47) and (B-48) into the right-hand side of (B-45) we get

$$\begin{aligned}
 & \lim_{|\sigma| \rightarrow 0} \left\{ \int_0^1 h_r^{(n)}(\xi_0) B(\xi - \xi_0, \sigma; \mu, M) \sqrt{\frac{1 - \xi_0}{\xi_0}} d\xi_0 \right. \\
 & \quad \left. + \log(\sigma^2) \left[-i\mu(1-M)h_r^{(n)}(\xi) \sqrt{\frac{1-\xi}{\xi}} + (i\mu)^2 k_r^{(n)}(\xi) \right] \right\} \\
 & = (i\mu)^2 k_r^{(n)}(1) \int_{\frac{\mu(1-\xi)}{(1-M)}}^{\infty} e^{-i\lambda} \frac{d\lambda}{\lambda} \\
 & \quad + 2 \log\left(\frac{8\xi(1-\xi)}{\beta}\right) \left[-i\mu(1-M)h_r^{(n)}(\xi) \sqrt{\frac{1-\xi}{\xi}} + (i\mu)^2 k_r^{(n)}(\xi) \right] \\
 & \quad - i\mu(1-M) \int_0^\xi \left[h_r^{(n)}(\xi_0) \sqrt{\frac{1-\xi_0}{\xi_0}} \exp\left(\frac{i\mu(\xi-\xi_0)}{(1+M)}\right) - \frac{h_r^{(n)}(\xi)(1-\xi)}{\sqrt{\xi_0(1-\xi_0)}} \right] \frac{d\xi_0}{(\xi-\xi_0)} \\
 & \quad + i\mu(1-M) \int_\xi^1 \left[h_r^{(n)}(\xi_0) \sqrt{\frac{1-\xi_0}{\xi_0}} \exp\left(\frac{i\mu(\xi-\xi_0)}{(1-M)}\right) - \frac{h_r^{(n)}(\xi)(1-\xi)}{\sqrt{\xi_0(1-\xi_0)}} \right] \frac{d\xi_0}{(\xi-\xi_0)} \\
 & \quad + (i\mu)^2 \int_0^\xi \left[k_r^{(n)}(\xi_0) \exp\left(\frac{i\mu(\xi-\xi_0)}{(1+M)}\right) - k_r^{(n)}(\xi) \sqrt{\frac{\xi(1-\xi)}{\xi_0(1-\xi_0)}} \right] \frac{d\xi_0}{(\xi-\xi_0)} \\
 & \quad - (i\mu)^2 \int_\xi^1 \left[k_r^{(n)}(\xi_0) \exp\left(\frac{i\mu(\xi-\xi_0)}{(1-M)}\right) - k_r^{(n)}(\xi) \sqrt{\frac{\xi(1-\xi)}{\xi_0(1-\xi_0)}} \right] \frac{d\xi_0}{(\xi-\xi_0)} .
 \end{aligned}$$

..... (B-49)

Again, a contribution of $O(\delta)$ does not appear on the right-hand side of (B-49) for the complete expression is independent of δ .

Finally, from formulae (B-25), (B-26), (B-38) and (B-49) we get

$$\begin{aligned}
& \lim_{|\sigma| \rightarrow 0} \left\{ \frac{1}{\sigma} \frac{d}{d\sigma} G_r^{(n)}(\xi, \sigma; \mu, M) \right. \\
& \quad \left. + \log(\sigma^2) \left[\beta^2 \frac{d}{d\xi} \left(h_r^{(n)}(\xi) \sqrt{\frac{1-\xi}{\xi}} \right) - 2(i\mu) h_r^{(n)}(\xi) \sqrt{\frac{1-\xi}{\xi}} + (i\mu)^2 k_r^{(n)}(\xi) \right] \right\} \\
& = \frac{2\beta^2}{\xi} h_r^{(n)}(\xi) \sqrt{\frac{1-\xi}{\xi}} + (i\mu)^2 k_r^{(n)}(1) \int_{\frac{\mu(1-\xi)}{(1-M)}}^{\infty} e^{-i\lambda} \frac{d\lambda}{\lambda} \\
& \quad + 2 \log\left(\frac{8\xi(1-\xi)}{\beta}\right) \left[\beta^2 \frac{d}{d\xi} \left(h_r^{(n)}(\xi) \sqrt{\frac{1-\xi}{\xi}} \right) - 2i\mu h_r^{(n)}(\xi) \sqrt{\frac{1-\xi}{\xi}} + (i\mu)^2 k_r^{(n)}(\xi) \right] \\
& \quad + \int_0^\xi \left[\frac{\beta^2 \xi_0}{\xi} \frac{d}{d\xi_0} \left\{ h_r^{(n)}(\xi_0) \sqrt{\frac{1-\xi_0}{\xi_0}} \exp\left(\frac{i\mu(\xi-\xi_0)}{(1+M)}\right) \right\} \right. \\
& \quad \quad \left. - \left[\beta^2 \frac{d}{d\xi} \left(h_r^{(n)}(\xi) \sqrt{\frac{1-\xi}{\xi}} \right) - i\mu(1-M) h_r^{(n)}(\xi) \sqrt{\frac{1-\xi}{\xi}} \right] \sqrt{\frac{\xi(1-\xi)}{\xi_0(1-\xi_0)}} \right] \frac{d\xi_0}{(\xi-\xi_0)} \\
& \quad - \int_\xi^1 \left[\frac{\beta^2 \xi_0}{\xi} \frac{d}{d\xi_0} \left\{ h_r^{(n)}(\xi_0) \sqrt{\frac{1-\xi_0}{\xi_0}} \exp\left(\frac{i\mu(\xi-\xi_0)}{(1-M)}\right) \right\} \right. \\
& \quad \quad \left. - \left[\beta^2 \frac{d}{d\xi} \left(h_r^{(n)}(\xi) \sqrt{\frac{1-\xi}{\xi}} \right) - i\mu(1+M) h_r^{(n)}(\xi) \sqrt{\frac{1-\xi}{\xi}} \right] \sqrt{\frac{\xi(1-\xi)}{\xi_0(1-\xi_0)}} \right] \frac{d\xi_0}{(\xi-\xi_0)} \\
& \quad - i\mu(1+M) \int_0^\xi \left[h_r^{(n)}(\xi_0) \sqrt{\frac{1-\xi_0}{\xi_0}} \exp\left(\frac{i\mu(\xi-\xi_0)}{(1+M)}\right) - \frac{h_r^{(n)}(\xi)(1-\xi)}{\sqrt{\xi_0(1-\xi_0)}} \right] \frac{d\xi_0}{(\xi-\xi_0)} \\
& \quad + i\mu(1-M) \int_\xi^1 \left[h_r^{(n)}(\xi_0) \sqrt{\frac{1-\xi_0}{\xi_0}} \exp\left(\frac{i\mu(\xi-\xi_0)}{(1-M)}\right) - \frac{h_r^{(n)}(\xi)(1-\xi)}{\sqrt{\xi_0(1-\xi_0)}} \right] \frac{d\xi_0}{(\xi-\xi_0)}
\end{aligned}$$

$$\begin{aligned}
 & + (i\mu)^2 \int_0^\xi \left[k_r^{(n)}(\xi_0) \exp\left(\frac{i\mu(\xi - \xi_0)}{(1+M)}\right) - k_r^{(n)}(\xi) \sqrt{\frac{\xi(1-\xi)}{\xi_0(1-\xi_0)}} \right] \frac{d\xi_0}{(\xi - \xi_0)} \\
 & - (i\mu)^2 \int_\xi^1 \left[k_r^{(n)}(\xi_0) \exp\left(\frac{i\mu(\xi - \xi_0)}{(1-M)}\right) - k_r^{(n)}(\xi) \sqrt{\frac{\xi(1-\xi)}{\xi_0(1-\xi_0)}} \right] \frac{d\xi_0}{(\xi - \xi_0)} \quad (B-50)
 \end{aligned}$$

By comparing like terms in formulae (B-24) and (B-50) we get

$$F_r^{(n)}(\xi, 0; \mu, M) = \left[-\beta^2 \frac{d}{d\xi} \left(h_r^{(n)}(\xi) \sqrt{\frac{1-\xi}{\xi}} \right) + 2i\mu h_r^{(n)}(\xi) \sqrt{\frac{1-\xi}{\xi}} - (i\mu)^2 k_r^{(n)}(\xi) \right], \quad \dots (B-51)$$

which is formula (3-23) of the main text, and

$$\begin{aligned}
 D_r^{(n)}(\xi, 0; \mu, M) & = \frac{2\beta^2}{\xi} h_r^{(n)}(\xi) \sqrt{\frac{1-\xi}{\xi}} + (i\mu)^2 k_r^{(n)}(1) \int_{\frac{\mu(1-\xi)}{(1-M)}}^\infty e^{-i\lambda} \frac{d\lambda}{\lambda} \\
 & - \left\{ 1 + 2 \log\left(\frac{8\xi(1-\xi)}{\beta}\right) \right\} \left[-\beta^2 \frac{d}{d\xi} \left(h_r^{(n)}(\xi) \sqrt{\frac{1-\xi}{\xi}} \right) \right. \\
 & \quad \left. + 2i\mu h_r^{(n)}(\xi) \sqrt{\frac{1-\xi}{\xi}} - (i\mu)^2 k_r^{(n)}(\xi) \right] \\
 & + \int_0^\xi \left[\frac{\beta^2 \xi_0}{\xi} \frac{d}{d\xi_0} \left\{ h_r^{(n)}(\xi_0) \sqrt{\frac{1-\xi_0}{\xi_0}} \exp\left(\frac{i\mu(\xi - \xi_0)}{(1+M)}\right) \right\} \right. \\
 & \quad \left. - \left\{ \beta^2 \frac{d}{d\xi} \left(h_r^{(n)}(\xi) \sqrt{\frac{1-\xi}{\xi}} \right) - i\mu(1-M) h_r^{(n)}(\xi) \sqrt{\frac{1-\xi}{\xi}} \right\} \sqrt{\frac{\xi(1-\xi)}{\xi_0(1-\xi_0)}} \right] \frac{d\xi_0}{(\xi - \xi_0)}
 \end{aligned}$$

$$\begin{aligned}
& - \int_{\xi}^1 \left[\frac{\beta^2 \xi_0}{\xi} \frac{d}{d\xi_0} \left\{ h_r^{(n)}(\xi_0) \sqrt{\frac{1-\xi_0}{\xi_0}} \exp\left(\frac{i\mu(\xi-\xi_0)}{(1-M)}\right) \right\} \right. \\
& \quad \left. - \left\{ \beta^2 \frac{d}{d\xi} \left(h_r^{(n)}(\xi) \sqrt{\frac{1-\xi}{\xi}} \right) - i\mu(1+M) h_r^{(n)}(\xi) \sqrt{\frac{1-\xi}{\xi}} \sqrt{\frac{\xi(1-\xi)}{\xi_0(1-\xi_0)}} \right\} \frac{d\xi_0}{(\xi-\xi_0)} \right. \\
& \quad - i\mu(1+M) \int_0^{\xi} \left[h_r^{(n)}(\xi_0) \sqrt{\frac{1-\xi_0}{\xi_0}} \exp\left(\frac{i\mu(\xi-\xi_0)}{(1+M)}\right) - \frac{h_r^{(n)}(\xi)(1-\xi)}{\sqrt{\xi_0(1-\xi_0)}} \right] \frac{d\xi_0}{(\xi-\xi_0)} \\
& \quad + i\mu(1-M) \int_{\xi}^1 \left[h_r^{(n)}(\xi_0) \sqrt{\frac{1-\xi_0}{\xi_0}} \exp\left(\frac{i\mu(\xi-\xi_0)}{(1-M)}\right) - \frac{h_r^{(n)}(\xi)(1-\xi)}{\sqrt{\xi_0(1-\xi_0)}} \right] \frac{d\xi_0}{(\xi-\xi_0)} \\
& \quad + (i\mu)^2 \int_0^{\xi} \left[k_r^{(n)}(\xi_0) \exp\left(\frac{i\mu(\xi-\xi_0)}{(1+M)}\right) - k_r^{(n)}(\xi) \sqrt{\frac{\xi(1-\xi)}{\xi_0(1-\xi_0)}} \right] \frac{d\xi_0}{(\xi-\xi_0)} \\
& \quad - (i\mu)^2 \int_{\xi}^1 \left[k_r^{(n)}(\xi_0) \exp\left(\frac{i\mu(\xi-\xi_0)}{(1-M)}\right) - k_r^{(n)}(\xi) \sqrt{\frac{\xi(1-\xi)}{\xi_0(1-\xi_0)}} \right] \frac{d\xi_0}{(\xi-\xi_0)} \quad (B-52)
\end{aligned}$$

We have therefore shown that the functions $D_r^{(n)}(\xi, \sigma; \mu, M)$ and $F_r^{(n)}(\xi, \sigma; \mu, M)$ remain finite when $|\sigma| \rightarrow 0$ by actually deriving the formulae (B-52) and (B-51) for $D_r^{(n)}(\xi, 0; \mu, M)$ and $F_r^{(n)}(\xi, 0; \mu, M)$ which show that they are finite except when ξ approaches 0 or 1.

The numerical evaluation of integrals appearing on the right-hand side of formula (B-52) is discussed in Appendix C.

We now return to formula (B-19) to get

$$\begin{aligned}
& G_r^{(n)}\left(\xi_1(x, z_0), \sigma(z, z_0); \frac{vc_1(z_0)}{\ell}, M\right) \\
& = E_r^{(n)}\left(\xi_1(x, z_0); \frac{vc_1(z_0)}{\ell}, M\right) \\
& \quad + \frac{1}{2}(\sigma(z, z_0))^2 D_r^{(n)}\left(\xi_1(x, z_0), \sigma(z, z_0); \frac{vc_1(z_0)}{\ell}, M\right) \\
& \quad + \frac{1}{2}(\sigma(z, z_0))^2 \{\log \sigma(z, z_0)\}^2 F_r^{(n)}\left(\xi_1(x, z_0), \sigma(z, z_0); \frac{vc_1(z_0)}{\ell}, M\right) \quad (B-53)
\end{aligned}$$

If we differentiate the formula (B-53) once and twice with respect to η_0 , where η_0 is defined in formula (2-28), we get respectively

$$\begin{aligned}
 & \frac{\partial}{\partial \eta_0} G_r^{(n)} \left(\xi_1(x, z_0), \sigma(z, z_0); \frac{vc_1(z_0)}{\ell}, M \right) \\
 &= s_1 \left(\frac{\partial \xi_1(x, z_0)}{\partial z_0} \right) \left[\frac{\partial E_r^{(n)}}{\partial \xi} \left(\xi; \frac{vc_1(z_0)}{\ell}, M \right) \right]_{\xi=\xi_1(x, z_0)} \\
 &+ \frac{vs_1}{\ell} c_1'(z_0) \left[\frac{\partial E_r^{(n)}}{\partial \mu} \left(\xi_1(x, z_0); \mu, M \right) \right]_{\mu=vc_1(z_0)/\ell} \\
 &+ s_1 \sigma(z, z_0) \left(\frac{\partial \sigma(z, z_0)}{\partial z_0} \right) D_r^{(n)} \left(\xi_1(x, z_0), \sigma(z, z_0); \frac{vc_1(z_0)}{\ell}, M \right) \\
 &+ s_1 \sigma(z, z_0) \left\{ 1 + \log(\sigma(z, z_0))^2 \right\} \left(\frac{\partial \sigma(z, z_0)}{\partial z_0} \right) F_r^{(n)} \left(\xi_1(x, z_0), \sigma(z, z_0); \frac{vc_1(z_0)}{\ell}, M \right) \\
 &+ \frac{1}{2} s_1 (\sigma(z, z_0))^2 \frac{d}{dz_0} \left[D_r^{(n)} \left(\xi_1(x, z_0), \sigma(z, z_0); \frac{vc_1(z_0)}{\ell}, M \right) \right] \\
 &+ \frac{1}{2} s_1 (\sigma(z, z_0))^2 \left\{ \log(\sigma(z, z_0))^2 \right\} \frac{d}{dz_0} \left[F_r^{(n)} \left(\xi_1(x, z_0), \sigma(z, z_0); \frac{vc_1(z_0)}{\ell}, M \right) \right] \\
 & \dots \dots (B-54)
 \end{aligned}$$

and

$$\begin{aligned}
 & \frac{\partial^2}{\partial \eta_0^2} G_r^{(n)} \left(\xi_1(x, z_0), \sigma(z, z_0); \frac{vc_1(z_0)}{\ell}, M \right) \\
 &= s_1^2 \left(\frac{\partial^2 \xi_1(x, z_0)}{\partial z_0^2} \right) \left[\frac{\partial E_r^{(n)}}{\partial \xi} \left(\xi; \frac{vc_1(z_0)}{\ell}, M \right) \right]_{\xi=\xi_1(x, z_0)}
 \end{aligned}$$

$$\begin{aligned}
& + \frac{v s_1^2}{l} c_1''(z_0) \left[\frac{\partial E_r^{(n)}}{\partial \mu} (\xi_1(x, z_0); \mu, M) \right]_{\mu = v c_1(z_0)/l} \\
& + s_1^2 \left(\frac{\partial \xi_1(x, z_0)}{\partial z_0} \right)^2 \left[\frac{\partial^2 E_r^{(n)}}{\partial \xi^2} \left(\xi; \frac{v c_1(z_0)}{l}, M \right) \right]_{\xi = \xi_1(x, z_0)} \\
& + \frac{2 v s_1^2}{l} c_1'(z_0) \left(\frac{\partial \xi_1(x, z_0)}{\partial z_0} \right) \left[\frac{\partial^2 E_r^{(n)}}{\partial \xi \partial \mu} (\xi; \mu, M) \right]_{\xi = \xi_1(x, z_0), \mu = v c_1(z_0)/l} \\
& + \frac{v^2 s_1^2}{l^2} (c_1'(z_0))^2 \left[\frac{\partial^2 E_r^{(n)}}{\partial \mu^2} (\xi_1(x, z_0); \mu, M) \right]_{\mu = v c_1(z_0)/l} \\
& + s_1^2 \left\{ \sigma(z, z_0) \frac{\partial^2 \sigma(z, z_0)}{\partial z_0^2} + \left(\frac{\partial \sigma(z, z_0)}{\partial z_0} \right)^2 \right\} D_r^{(n)} \left(\xi_1(x, z_0), \sigma(z, z_0); \frac{v c_1(z_0)}{l}, M \right) \\
& + s_1^2 \left\{ \sigma(z, z_0) \left\{ 1 + \log(\sigma(z, z_0))^2 \right\} \frac{\partial^2 \sigma(z, z_0)}{\partial z_0^2} \right. \\
& \quad \left. + \left\{ 3 + \log(\sigma(z, z_0))^2 \right\} \left(\frac{\partial \sigma(z, z_0)}{\partial z_0} \right)^2 \right\} F_r^{(n)} \left(\xi_1(x, z_0), \sigma(z, z_0); \frac{v c_1(z_0)}{l}, M \right) \\
& + 2 s_1^2 \sigma(z, z_0) \left(\frac{\partial \sigma(z, z_0)}{\partial z_0} \right) \frac{d}{dz_0} \left[D_r^{(n)} \left(\xi_1(x, z_0), \sigma(z, z_0); \frac{v c_1(z_0)}{l}, M \right) \right] \\
& + 2 s_1^2 \sigma(z, z_0) \left\{ 1 + \log(\sigma(z, z_0))^2 \right\} \left(\frac{\partial \sigma(z, z_0)}{\partial z_0} \right) \frac{d}{dz_0} \left[F_r^{(n)} \left(\xi_1(x, z_0), \sigma(z, z_0); \frac{v c_1(z_0)}{l}, M \right) \right] \\
& + \frac{1}{2} s_1^2 (\sigma(z, z_0))^2 \frac{d^2}{dz_0^2} \left[D_r^{(n)} \left(\xi_1(x, z_0), \sigma(z, z_0); \frac{v c_1(z_0)}{l}, M \right) \right] \\
& + \frac{1}{2} s_1^2 (\sigma(z, z_0))^2 \left\{ \log(\sigma(z, z_0))^2 \right\} \frac{d^2}{dz_0^2} \left[F_r^{(n)} \left(\xi_1(x, z_0), \sigma(z, z_0); \frac{v c_1(z_0)}{l}, M \right) \right] \quad (B-55)
\end{aligned}$$

where $c_1'(z_0)$ and $c_1''(z_0)$ are respectively the first and second derivatives of $c_1(z_0)$.

Then, from formulae (B-54) and (B-55) we get directly

$$\begin{aligned}
 & \lim_{\eta_0 \rightarrow \eta} \frac{\partial}{\partial \eta_0} G_r^{(n)} \left(\xi_1(x, z_0), \sigma(z, z_0); \frac{vc_1(z_0)}{\ell}, M \right) \\
 &= s_1 \left(\frac{\partial \xi_1(x, z)}{\partial z} \right) \left[\frac{\partial E_r^{(n)}}{\partial \xi} \left(\xi; \frac{vc_1(z)}{\ell}, M \right) \right]_{\xi = \xi_1(x, z)} \\
 & \quad + \frac{vs_1}{\ell} c_1'(z) \left[\frac{\partial E_r^{(n)}}{\partial \mu} \left(\xi_1(x, z); \mu, M \right) \right]_{\mu = vc_1(z)/\ell} \tag{B-56}
 \end{aligned}$$

and

$$\begin{aligned}
 & \lim_{\eta_0 \rightarrow \eta} \left\{ \frac{\partial^2}{\partial \eta_0^2} G_r^{(n)} \left(\xi_1(x, z_0), \sigma(z, z_0); \frac{vc_1(z_0)}{\ell}, M \right) \right. \\
 & \quad \left. - s_1^2 \left(\frac{\partial \sigma(z, z_0)}{\partial z_0} \right)^2 \left\{ \log(\sigma(z, z_0))^2 \right\} F_r^{(n)} \left(\xi_1(x, z), 0; \frac{vc_1(z)}{\ell}, M \right) \right\} \\
 &= s_1^2 \left(\frac{\partial^2 \xi_1(x, z)}{\partial z^2} \right) \left[\frac{\partial E_r^{(n)}}{\partial \xi} \left(\xi; \frac{vc_1(z)}{\ell}, M \right) \right]_{\xi = \xi_1(x, z)} \\
 & \quad + \frac{vs_1^2}{\ell} c_1''(z) \left[\frac{\partial E_r^{(n)}}{\partial \mu} \left(\xi_1(x, z); \mu, M \right) \right]_{\mu = vc_1(z)/\ell} \\
 & \quad + s_1^2 \left(\frac{\partial \xi_1(x, z)}{\partial z} \right)^2 \left[\frac{\partial^2 E_r^{(n)}}{\partial \xi^2} \left(\xi; \frac{vc_1(z)}{\ell}, M \right) \right]_{\xi = \xi_1(x, z)} \\
 & \quad + \frac{2vs_1^2}{\ell} c_1'(z) \left(\frac{\partial \xi_1(x, z)}{\partial z} \right) \left[\frac{\partial^2 E_r^{(n)}}{\partial \xi \partial \mu} \left(\xi; \mu, M \right) \right]_{\xi = \xi_1(x, z), \mu = vc_1(z)/\ell}
 \end{aligned}$$

$$\begin{aligned}
& + \frac{v^2 s_1^2}{l^2} (c_1'(z))^2 \left[\frac{\partial^2 E_r^{(n)}}{\partial \mu^2} (\xi_1(x, z); \mu, M) \right]_{\mu = v c_1(z)/l} \\
& + s_1^2 \left[\left(\frac{\partial \sigma(z, z_0)}{\partial z_0} \right)^2 \right]_{z_0 = z} D_r^{(n)} \left(\xi_1(x, z), 0; \frac{v c_1(z)}{l}, M \right) \\
& + 3 s_1^2 \left[\left(\frac{\partial \sigma(z, z_0)}{\partial z_0} \right)^2 \right] F_r^{(n)} \left(\xi_1(x, z), 0; \frac{v c_1(z)}{l}, M \right). \tag{B-57}
\end{aligned}$$

Now, from formula (B-12) we get

$$\begin{aligned}
\frac{\partial \xi_1(x, z)}{\partial z} &= - \frac{c_1'(z)}{(c_1(z))^2} (x - e_1(z)) - \frac{e_1'(z)}{c_1(z)} \\
&= - \frac{1}{c_1(z)} \left\{ c_1'(z) \xi_1(x, z) + e_1'(z) \right\} \tag{B-58}
\end{aligned}$$

and

$$\begin{aligned}
\frac{\partial^2 \xi_1(x, z)}{\partial z^2} &= \frac{2c_1'(z)}{(c_1(z))^2} \left\{ c_1'(z) \xi_1(x, z) + e_1'(z) \right\} \\
&\quad - \frac{1}{c_1(z)} \left\{ c_1''(z) \xi_1(x, z) + e_1''(z) \right\}. \tag{B-59}
\end{aligned}$$

From formula (B-13) we get

$$\begin{aligned}
\frac{\partial \sigma(z, z_0)}{\partial z_0} &= - \frac{1}{c_1(z_0)} - \frac{c_1'(z_0)}{(c_1(z_0))^2} (z - z_0) \\
&= - \frac{1}{c_1(z_0)} - \frac{c_1'(z_0)}{c_1(z_0)} \sigma(z, z_0). \tag{B-60}
\end{aligned}$$

From formulae (B-22) and (B-39) we have, for $\xi > 0$,

$$E_r^{(n)}(\xi; \mu, M) = 2k_r^{(n)}(\xi). \tag{B-61}$$

Hence

$$\frac{\partial E_r^{(n)}}{\partial \xi} (\xi; \mu, M) = 2h_r^{(n)}(\xi) \sqrt{\frac{1-\xi}{\xi}} \quad (\text{B-62})$$

$$\frac{\partial E_r^{(n)}}{\partial \mu} (\xi; \mu, M) = 0 \quad (\text{B-63})$$

$$\frac{\partial^2 E_r^{(n)}}{\partial \xi^2} (\xi; \mu, M) = 2 \frac{d}{d\xi} \left(h_r^{(n)}(\xi) \sqrt{\frac{1-\xi}{\xi}} \right) \quad (\text{B-64})$$

$$\frac{\partial^2 E_r^{(n)}}{\partial \xi \partial \mu} (\xi; \mu, M) = 0 \quad (\text{B-65})$$

$$\frac{\partial^2 E_r^{(n)}}{\partial \mu^2} (\xi; \mu, M) = 0 \quad (\text{B-66})$$

From formulae (B-56) and (B-57), on using relations (B-58) to (B-66) we then get

$$\begin{aligned} & \lim_{\eta_0 \rightarrow \eta} \frac{\partial}{\partial \eta_0} G_r^{(n)} \left(\xi_1(x, z_0), \sigma(z, z_0); \frac{vc_1(z_0)}{l}, M \right) \\ &= -2 \frac{s_1}{c_1(z)} \left\{ c_1'(z) \xi_1(x, z) + e_1'(z) \right\} h_r^{(n)}(\xi) \sqrt{\frac{1-\xi}{\xi}} \quad (\text{B-67}) \end{aligned}$$

and

$$\begin{aligned}
& \lim_{\eta_0 \rightarrow \eta} \left\{ \frac{\partial^2}{\partial \eta_0^2} G_r^{(n)} \left(\xi_1(x, z_0), \sigma(z, z_0); \frac{vc_1(z_0)}{l}, M \right) \right. \\
& \quad \left. - \frac{s_1^2}{(c_1(z))^2} \left\{ \log(\sigma(z, z_0))^2 \right\} F_r^{(n)} \left(\xi_1(x, z), 0; \frac{vc_1(z)}{l}, M \right) \right\} \\
& = 2s_1^2 \left[\frac{2c_1'(z)}{(c_1(z))^2} \{c_1'(z)\xi_1(x, z) + e_1'(z)\} \right. \\
& \quad \left. - \frac{1}{c_1(z)} \{c_1''(z)\xi_1(x, z) + e_1''(z)\} \right] h_r^{(n)}(\xi) \sqrt{\frac{1-\xi}{\xi}} \\
& + \frac{2s_1^2}{(c_1(z))^2} \{c_1'(z)\xi_1(x, z) + e_1'(z)\}^2 \frac{d}{d\xi} \left(h_r^{(n)}(\xi) \sqrt{\frac{1-\xi}{\xi}} \right) \\
& + \frac{s_1^2}{(c_1(z))^2} D_r^{(n)} \left(\xi_1(x, z), 0; \frac{vc_1(z)}{l}, M \right) \\
& + \frac{3s_1^2}{(c_1(z))^2} F_r^{(n)} \left(\xi_1(x, z), 0; \frac{vc_1(z)}{l}, M \right) . \tag{B-68}
\end{aligned}$$

Now, from formulae (3-22) and (B-17) we get

$$\begin{aligned}
 & I_r^{(n)*} \left(\bar{\xi}_p^{(n_1')}, \chi_q^{(m_1', \bar{m}_1)}, \eta_0; \nu, M \right) \\
 &= \frac{\ell^2}{s_1^2} G_r^{(n)} \left(\xi_1 \left(\bar{x}_{p,q}^{(n_1', m_1', \bar{m}_1)}, z_0 \right), \sigma \left(s_1 \chi_q^{(m_1', \bar{m}_1)}, z_0 \right); \frac{\nu c_1(z_0)}{\ell}, M \right) \\
 &\quad - \left(\frac{\ell}{c_1(z_q^{(m_1', \bar{m}_1)})} \right)^2 \left(\chi_q^{(m_1', \bar{m}_1)} - \eta_0 \right)^2 \log \left| \chi_q^{(m_1', \bar{m}_1)} - \eta_0 \right| \\
 &\quad \times F_r^{(n)} \left(\bar{\xi}_p^{(n_1')}, 0, \frac{\nu c_1(z_q^{(m_1', \bar{m}_1)})}{\ell}, M \right) \\
 &\dots\dots (B-69)
 \end{aligned}$$

and then from formulae (B-69) and (B-22) we get

$$\begin{aligned}
 & I_r^{(n)*} \left(\bar{\xi}_p^{(n_1')}, \chi_q^{(m_1', \bar{m}_1)}, \chi_q^{(m_1', \bar{m}_1)}; \nu, M \right) \\
 &= \frac{2\ell^2}{s_1^2} \int_0^{\bar{\xi}_p^{(n_1')}} h_r^{(n)}(\xi_0) \sqrt{\frac{1-\xi_0}{\xi_0}} d\xi_0 \quad (B-70)
 \end{aligned}$$

By using formula (B-67) we get from formula (B-69) after differentiation with respect to η_0

$$\begin{aligned}
 & \left[\frac{\partial}{\partial \eta_0} \left\{ I_r^{(n)*} \left(\bar{\xi}_p^{(n_1')}, \chi_q^{(m_1', \bar{m}_1)}, \eta_0; \nu, M \right) \right\} \right]_{\eta_0 = \chi_q^{(m_1', \bar{m}_1)}} \\
 &= \left[- \frac{2\ell^2}{s_1 c_1(z)} \{ c_1'(z)\xi + e_1'(z) \} h_r^{(n)}(\xi) \sqrt{\frac{1-\xi}{\xi}} \right]_{\xi = \bar{\xi}_p^{(n_1')}, z = s_1 \chi_q^{(m_1', \bar{m}_1)}} \\
 &\dots\dots (B-71)
 \end{aligned}$$

and by using formula (B-68) we get from formula (B-69) after differentiation twice with respect to η_0

$$\begin{aligned} & \left[\frac{\partial^2}{\partial \eta_0^2} \left\{ I_r^{(n)*} \left(\bar{\xi}_p^{(n_1')}, \chi_q^{(m_1', \bar{m}_1)}, \eta_0; \nu, M \right) \right\} \right]_{\eta_0 = \chi_q^{(m_1', \bar{m}_1)}} \\ &= \left[2\ell^2 \left\{ \frac{2c_1'(z)}{(c_1(z))^2} \{c_1'(z)\xi + e_1'(z)\} - \frac{1}{c_1(z)} \{c_1''(z)\xi + e_1''(z)\} \right\} h_r^{(n)}(\xi) \sqrt{\frac{1-\xi}{\xi}} \right. \\ &+ \frac{2\ell^2}{(c_1(z))^2} \{c_1'(z)\xi + e_1'(z)\}^2 \frac{d}{d\xi} \left(h_r^{(n)}(\xi) \sqrt{\frac{1-\xi}{\xi}} \right) \\ &+ \frac{\ell^2}{(c_1(z))^2} D_r^{(n)} \left(\xi, 0; \frac{\nu c_1(z)}{\ell}, M \right) \\ &\left. - \frac{\ell^2}{(c_1(z))^2} \left\{ \log \left(\frac{c_1(z)}{s_1} \right)^2 \right\} F_r^{(n)} \left(\xi, 0; \frac{\nu c_1(z)}{\ell}, M \right) \right]_{\xi = \bar{\xi}_p^{(n_1')}, z = s_1 \chi_q^{(m_1', \bar{m}_1)}} \dots (B-72) \end{aligned}$$

If we substitute for $F_r^{(n)} \left(\xi, 0; \frac{\nu c_1(z)}{\ell}, M \right)$ from formula (B-51) and for $D_r^{(n)} \left(\xi, 0; \frac{\nu c_1(z)}{\ell}, M \right)$ from formula (B-52) into formula (B-72) we get

$$\begin{aligned} & \left[\frac{\partial^2}{\partial \eta_0^2} \left\{ I_r^{(n)*}(\xi, \eta, \eta_0; \nu, M) \right\} \right]_{\eta_0 = \eta} \\ &= \frac{2\ell^2}{(c_1(z))^2} \left[2c_1'(z) \{c_1'(z)\xi + e_1'(z)\} - c_1(z) \{c_1''(z)\xi + e_1''(z)\} \right] h_r^{(n)}(\xi) \sqrt{\frac{1-\xi}{\xi}} \\ &+ \frac{2\ell^2}{(c_1(z))^2} \{c_1'(z)\xi + e_1'(z)\}^2 \frac{d}{d\xi} \left(h_r^{(n)}(\xi) \sqrt{\frac{1-\xi}{\xi}} \right) \end{aligned}$$

$$\begin{aligned}
& + \frac{2l^2}{(c_1(z))^2} \frac{\beta^2}{\xi} h_r^{(n)}(\xi) \sqrt{\frac{1-\xi}{\xi}} + \frac{l^2}{(c_1(z))^2} (i\mu)^2 k_r^{(n)}(l) \int_0^\infty e^{-i\lambda} \frac{d\lambda}{\lambda} \\
& - \frac{l^2}{(c_1(z))^2} \left\{ 1 + 2 \log \left(\frac{8c_1(z)\xi(1-\xi)}{\beta s_1} \right) \right\} \left[-\beta^2 \frac{d}{d\xi} \left(h_r^{(n)}(\xi) \sqrt{\frac{1-\xi}{\xi}} \right) \right. \\
& \qquad \qquad \qquad \left. + 2i\mu h_r^{(n)}(\xi) \sqrt{\frac{1-\xi}{\xi}} - (i\mu)^2 k_r^{(n)}(\xi) \right] \\
& + \frac{l^2}{(c_1(z))^2} \int_0^\xi \left[\frac{\beta^2 \xi_0}{\xi} \frac{d}{d\xi_0} \left\{ h_r^{(n)}(\xi_0) \sqrt{\frac{1-\xi_0}{\xi_0}} \exp \left(\frac{i\mu(\xi-\xi_0)}{(1+M)} \right) \right\} \right. \\
& \qquad \qquad \qquad - \left\{ \beta^2 \frac{d}{d\xi} \left(h_r^{(n)}(\xi) \sqrt{\frac{1-\xi}{\xi}} \right) \right. \\
& \qquad \qquad \qquad \left. \left. - i\mu(1-M) h_r^{(n)}(\xi) \sqrt{\frac{1-\xi}{\xi}} \right\} \sqrt{\frac{\xi(1-\xi)}{\xi_0(1-\xi_0)}} \right] \frac{d\xi_0}{(\xi-\xi_0)} \\
& - \frac{l^2}{(c_1(z))^2} \int_\xi^1 \left[\frac{\beta^2 \xi_0}{\xi} \frac{d}{d\xi_0} \left\{ h_r^{(n)}(\xi_0) \sqrt{\frac{1-\xi_0}{\xi_0}} \exp \left(\frac{i\mu(\xi-\xi_0)}{(1-M)} \right) \right\} \right. \\
& \qquad \qquad \qquad - \left\{ \beta^2 \frac{d}{d\xi} \left(h_r^{(n)}(\xi) \sqrt{\frac{1-\xi}{\xi}} \right) \right. \\
& \qquad \qquad \qquad \left. \left. - i\mu(1+M) h_r^{(n)}(\xi) \sqrt{\frac{1-\xi}{\xi}} \right\} \sqrt{\frac{\xi(1-\xi)}{\xi_0(1-\xi_0)}} \right] \frac{d\xi_0}{(\xi-\xi_0)} \\
& - \frac{l^2}{(c_1(z))^2} (i\mu)(1+M) \int_0^\xi \left[h_r^{(n)}(\xi_0) \sqrt{\frac{1-\xi_0}{\xi_0}} \exp \left(\frac{i\mu(\xi-\xi_0)}{(1+M)} \right) \right. \\
& \qquad \qquad \qquad \left. - \frac{h_r^{(n)}(\xi)(1-\xi)}{\sqrt{\xi_0(1-\xi_0)}} \right] \frac{d\xi_0}{(\xi-\xi_0)}
\end{aligned}$$

$$\begin{aligned}
 & + \frac{\ell^2}{(c_1(z))^2} (i\mu)(1-M) \int_{\xi}^1 \left[h_r^{(n)}(\xi_0) \sqrt{\frac{1-\xi_0}{\xi_0}} \exp\left(\frac{i\mu(\xi-\xi_0)}{(1-M)}\right) \right. \\
 & \qquad \qquad \qquad \left. - \frac{h_r^{(n)}(\xi)(1-\xi)}{\sqrt{\xi_0(1-\xi_0)}} \right] \frac{d\xi_0}{(\xi-\xi_0)} \\
 & + \frac{\ell^2}{(c_1(z))^2} (i\mu)^2 \int_0^{\xi} \left[k_r^{(n)}(\xi_0) \exp\left(\frac{i\mu(\xi-\xi_0)}{(1+M)}\right) - k_r^{(n)}(\xi) \sqrt{\frac{\xi(1-\xi)}{\xi_0(1-\xi_0)}} \right] \frac{d\xi_0}{(\xi-\xi_0)} \\
 & - \frac{\ell^2}{(c_1(z))^2} (i\mu)^2 \int_{\xi}^1 \left[k_r^{(n)}(\xi_0) \exp\left(\frac{i\mu(\xi-\xi_0)}{(1-M)}\right) - k_r^{(n)}(\xi) \sqrt{\frac{\xi(1-\xi)}{\xi_0(1-\xi_0)}} \right] \frac{d\xi_0}{(\xi-\xi_0)} \\
 & \qquad \qquad \qquad \dots\dots\dots (B-73)
 \end{aligned}$$

where $\xi = \bar{\xi}_p^{(n_1')}$ (B-74)

$\eta = \chi_q^{(m_1', \bar{m}_1)}$ (B-75)

$z = s_1 \chi_q^{(m_1', \bar{m}_1)}$ (B-76)

and

$\mu = \frac{vc_1(s_1 \chi_q^{(m_1', \bar{m}_1)})}{\ell}$ (B-77)

We have now obtained our objective in formulae (B-70), (B-71) and (B-73), namely tractable expressions for $I_r^{(n)*}(\bar{\xi}_p^{(n_1')}, \chi_q^{(m_1', \bar{m}_1)}, \chi_q^{(m_1', \bar{m}_1)}; \nu, M)$,

$$\left[\frac{\partial}{\partial \eta_0} \left\{ I_r^{(n)*}(\bar{\xi}_p^{(n_1')}, \chi_q^{(m_1', \bar{m}_1)}, \eta_0; \nu, M) \right\} \right]_{\eta_0 = \chi_q^{(m_1', \bar{m}_1)}}$$

and

$$\left[\frac{\partial^2}{\partial \eta_0^2} \left\{ I_r^{(n)*}(\bar{\xi}_p^{(n_1')}, \chi_q^{(m_1', \bar{m}_1)}, \eta_0; \nu, M) \right\} \right]_{\eta_0 = \chi_q^{(m_1', \bar{m}_1)}}$$

The numerical evaluation of the integrals appearing on the right-hand side of formula (B-73) is discussed in Appendix C.

Appendix C

NUMERICAL EVALUATION OF CERTAIN INTEGRALS APPEARING IN APPENDIX B

In this Appendix we discuss the numerical evaluation of the following integrals, which appear on the right-hand side of formula (B-73).

$$\int_0^{\xi} \left[\frac{\beta^2 \xi_0}{\xi} \frac{d}{d\xi_0} \left\{ h_r^{(n)}(\xi_0) \sqrt{\frac{1-\xi_0}{\xi_0}} \exp\left(\frac{i\mu(\xi-\xi_0)}{(1+M)}\right) \right\} \right. \\ \left. - \left\{ \beta^2 \frac{d}{d\xi} \left(h_r^{(n)}(\xi) \sqrt{\frac{1-\xi}{\xi}} \right) - i\mu(1-M) h_r^{(n)}(\xi) \sqrt{\frac{1-\xi}{\xi}} \right\} \sqrt{\frac{\xi(1-\xi)}{\xi_0(1-\xi_0)}} \right] \frac{d\xi_0}{(\xi-\xi_0)} \quad \dots\dots (C-1)$$

$$\int_{\xi}^1 \left[\frac{\beta^2 \xi_0}{\xi} \frac{d}{d\xi_0} \left\{ h_r^{(n)}(\xi_0) \sqrt{\frac{1-\xi_0}{\xi_0}} \exp\left(\frac{i\mu(\xi-\xi_0)}{(1-M)}\right) \right\} \right. \\ \left. - \left\{ \beta^2 \frac{d}{d\xi} \left(h_r^{(n)}(\xi) \sqrt{\frac{1-\xi}{\xi}} \right) - i\mu(1+M) h_r^{(n)}(\xi) \sqrt{\frac{1-\xi}{\xi}} \right\} \sqrt{\frac{\xi(1-\xi)}{\xi_0(1-\xi_0)}} \right] \frac{d\xi_0}{(\xi-\xi_0)} \quad \dots\dots (C-2)$$

$$\int_0^{\xi} \left[h_r^{(n)}(\xi_0) \sqrt{\frac{1-\xi_0}{\xi_0}} \exp\left(\frac{i\mu(\xi-\xi_0)}{(1+M)}\right) - \frac{h_r^{(n)}(\xi)(1-\xi)}{\sqrt{\xi_0(1-\xi_0)}} \right] \frac{d\xi_0}{(\xi-\xi_0)} \quad (C-3)$$

$$\int_{\xi}^1 \left[h_r^{(n)}(\xi_0) \sqrt{\frac{1-\xi_0}{\xi_0}} \exp\left(\frac{i\mu(\xi-\xi_0)}{(1-M)}\right) - \frac{h_r^{(n)}(\xi)(1-\xi)}{\sqrt{\xi_0(1-\xi_0)}} \right] \frac{d\xi_0}{(\xi-\xi_0)} \quad (C-4)$$

$$\int_0^{\xi} \left[k_r^{(n)}(\xi_0) \exp\left(\frac{i\mu(\xi-\xi_0)}{(1+M)}\right) - k_r^{(n)}(\xi) \sqrt{\frac{\xi(1-\xi)}{\xi_0(1-\xi_0)}} \right] \frac{d\xi_0}{(\xi-\xi_0)} \quad (C-5)$$

and

$$\int_{\xi}^1 \left[k_r^{(n)}(\xi_0) \exp\left(\frac{i\mu(\xi-\xi_0)}{(1-M)}\right) - k_r^{(n)}(\xi) \sqrt{\frac{\xi(1-\xi)}{\xi_0(1-\xi_0)}} \right] \frac{d\xi_0}{(\xi-\xi_0)} \quad (C-6)$$

We recall from formula (2-51) of the main text that the polynomial $h_r^{(n)}(\xi_0)$ of degree $(n-1)$ in ξ_0 is defined by the formula

$$h_r^{(n)}(\xi_0) = \prod_{\substack{k=1 \\ k \neq r}}^n \left(\frac{\xi_0 - \xi_k^{(n)}}{\xi_r^{(n)} - \xi_k^{(n)}} \right), \quad r = 1(1)n, \quad (C-7)$$

where the points $\xi_r^{(n)}$, $r = 1(1)n$, are the zeros of a polynomial $l_n(\xi_0)$ of degree n in ξ_0 which is such that

$$\int_0^1 \xi_0^{k-1} l_n(\xi_0) \sqrt{\frac{1-\xi_0}{\xi_0}} d\xi_0 = 0, \quad k = 1(1)n. \quad (C-8)$$

Let us express ξ_0 in $(0,1)$ in terms of θ_0 in $(0,\pi)$ by means of the formula

$$\xi_0 = \frac{1}{2}(1 - \cos \theta_0). \quad (C-9)$$

We then find that we may take

$$l_n(\xi_0) = \frac{\cos(n + \frac{1}{2})\theta_0}{\cos \frac{1}{2}\theta_0} \quad (C-10)$$

from which it follows that

$$\xi_k^{(n)} = \frac{1}{2} \left[1 - \cos \left(\frac{2k-1}{2n+1} \pi \right) \right], \quad k = 1(1)n. \quad (C-11)$$

The polynomial $h_r^{(n)}(\xi_0)$ may be given in terms of the polynomials

$$l_{k-1}(\xi_0) = \frac{\cos(k - \frac{1}{2})\theta_0}{\cos \frac{1}{2}\theta_0}, \quad k = 1(1)n, \quad (C-12)$$

by means of the formula

$$h_r^{(n)}(\xi_0) = \frac{4}{(2n+1)} (1 - \xi_r^{(n)}) \sum_{k=1}^n l_{k-1}(\xi_r^{(n)}) l_{k-1}(\xi_0), \quad r = 1(1)n. \quad (C-13)$$

The formula (C-13) is easily verified. Since each side of (C-13) is a polynomial of degree $(n-1)$ in ξ_0 and since the $\ell_{k-1}(\xi_0)$, $k=1(1)n$, are linearly independent and orthogonal with respect to the weight function $\sqrt{(1-\xi_0)/\xi_0}$, it is sufficient to show that

$$\begin{aligned} \int_0^1 h_r^{(n)}(\xi_0) \ell_{k-1}(\xi_0) \sqrt{\frac{1-\xi_0}{\xi_0}} d\xi_0 &= \frac{4}{(2n+1)} (1-\xi_r^{(n)}) \ell_{k-1}(\xi_r^{(n)}) \int_0^1 \left(\ell_{k-1}(\xi_0) \right)^2 \\ &\quad \times \sqrt{\frac{1-\xi_0}{\xi_0}} d\xi_0 \\ &= \frac{2\pi}{(2n+1)} (1-\xi_r^{(n)}) \ell_{k-1}(\xi_r^{(n)}) \begin{cases} r=1(1)n, \\ k=1(1)n. \end{cases} \quad (\text{C-14}) \end{aligned}$$

Now,

$$\begin{aligned} \int_0^1 h_r^{(n)}(\xi_0) \ell_{k-1}(\xi_0) \sqrt{\frac{1-\xi_0}{\xi_0}} d\xi_0 &= \ell_{k-1}(\xi_r^{(n)}) H_r^{(n)} \\ &\quad + \int_0^1 h_r^{(n)}(\xi_0) \left\{ \ell_{k-1}(\xi_0) - \ell_{k-1}(\xi_r^{(n)}) \right\} \sqrt{\frac{1-\xi_0}{\xi_0}} d\xi_0 \\ &\quad \dots\dots (\text{C-15}) \end{aligned}$$

where, according to formulae (2-63) and (2-67) of the main text,

$$\begin{aligned} H_r^{(n)} &= \int_0^1 h_r^{(n)}(\xi_0) \sqrt{\frac{1-\xi_0}{\xi_0}} d\xi_0 \\ &= \frac{2\pi}{(2n+1)} (1-\xi_r^{(n)}) \quad . \quad (\text{C-16}) \end{aligned}$$

Since the points $\xi_r^{(n)}$, $r=1(1)n$, are the zeros of the polynomial $\ell_n(\xi_0)$, it follows from the definition (C-7) of the polynomials $h_r^{(n)}(\xi_0)$ that $(\xi_0 - \xi_r^{(n)}) h_r^{(n)}(\xi_0)$ is proportional to $\ell_n(\xi_0)$. Hence, by using (C-8) we get

$$\begin{aligned}
& \int_0^1 h_r^{(n)}(\xi_0) \left\{ l_{k-1}(\xi_0) - l_{k-1}(\xi_r^{(n)}) \right\} \sqrt{\frac{1-\xi_0}{\xi_0}} d\xi_0 \\
&= \int_0^1 (\xi_0 - \xi_r^{(n)}) h_r^{(n)}(\xi_0) \left\{ \frac{l_{k-1}(\xi_0) - l_{k-1}(\xi_r^{(n)})}{\xi_0 - \xi_r^{(n)}} \right\} \sqrt{\frac{1-\xi_0}{\xi_0}} d\xi_0 \\
&= 0 .
\end{aligned} \tag{C-17}$$

In view of (C-16) and (C-17) formula (C-15) becomes identical with formula (C-14) which is accordingly proved and hence the formula (C-13) is verified.

The quantities $l_{k-1}(\xi_r^{(n)})$ may, with advantage, be evaluated by using the recurrence relations

$$l_{k-1}(\xi_r^{(n)}) = 2(1 - 2\xi_r^{(n)}) l_{k-2}(\xi_r^{(n)}) - l_{k-3}(\xi_r^{(n)}) \tag{C-18}$$

and the starting values

$$l_{-1}(\xi_0) = 1 \tag{C-19}$$

$$l_0(\xi_0) = 1 . \tag{C-20}$$

If we introduce the functions $L_{k-1}(\xi_0)$, $k=1(1)n$, by means of the formula

$$L_{k-1}(\xi_0) = \int_0^{\xi_0} l_{k-1}(u) \sqrt{\frac{1-u}{u}} du \tag{C-21}$$

then, according to formulae (B-39) and (C-13), we have

$$\begin{aligned}
l_r^{(n)}(\xi_0) &= \int_0^{\xi_0} h_r^{(n)}(u) \sqrt{\frac{1-u}{u}} du \\
&= \frac{4}{(2n+1)} (1 - \xi_r^{(n)}) \sum_{k=1}^n l_{k-1}(\xi_r^{(n)}) L_{k-1}(\xi_0) .
\end{aligned} \tag{C-22}$$

By using the explicit formula (C-12) for $L_{k-1}(u)$ in the integrand of formula (C-21) we get the explicit formula

$$L_{k-1}(\xi_0) = \begin{cases} \frac{1}{2}(\theta_0 + \sin \theta_0) & k = 1 \\ \frac{1}{2} \left(\frac{\sin(k-1)\theta_0}{(k-1)} + \frac{\sin k\theta_0}{k} \right) & k \geq 2. \end{cases} \quad (C-23)$$

From the transformation of variables (C-9) we get

$$\sin \theta_0 = 2\sqrt{\xi_0(1-\xi_0)} \quad (C-24)$$

When ξ_0 is near to 0 we have, from (C-9), that θ_0 is near to 0 and therefore from (C-24) we get

$$\theta_0 = 2\sqrt{\xi_0(1-\xi_0)} \sum_{r=0}^{\infty} \frac{(2r)!}{(r!)^2} \frac{\{\xi_0(1-\xi_0)\}^r}{(2r+1)}, \quad 0 \leq \xi_0 \leq \frac{1}{2}. \quad (C-25)$$

When ξ_0 is near to 1 we have, from (C-9), that θ_0 is near to π and therefore from (C-24) we get

$$\theta_0 = \pi - 2\sqrt{\xi_0(1-\xi_0)} \sum_{r=0}^{\infty} \frac{(2r)!}{(r!)^2} \frac{\{\xi_0(1-\xi_0)\}^r}{(2r+1)}, \quad \frac{1}{2} \leq \xi_0 \leq 1. \quad (C-26)$$

The infinite series in formulae (C-25) and (C-26) is convergent for $0 \leq \xi_0 \leq 1$. Therefore, from formulae (C-23) to (C-26), we get

$$L_0(\xi_0) = \begin{cases} \sqrt{\xi_0(1-\xi_0)} \left\{ 2 + \xi_0(1-\xi_0) \sum_{r=0}^{\infty} \frac{(2r+2)!}{((r+1)!)^2} \frac{\{\xi_0(1-\xi_0)\}^r}{(2r+3)} \right\} & 0 \leq \xi_0 \leq \frac{1}{2} \\ \frac{1}{2}\pi - \{\xi_0(1-\xi_0)\}^{\frac{1}{2}} \sum_{r=0}^{\infty} \frac{(2r+2)!}{((r+1)!)^2} \frac{\{\xi_0(1-\xi_0)\}^r}{(2r+3)} & \frac{1}{2} \leq \xi_0 \leq 1. \end{cases}$$

..... (C-27)

Further

$$\begin{aligned} \frac{\sin k\theta_0}{k} &= \frac{\sin k\theta_0}{k \sin \theta_0} \sin \theta_0 \\ &= 2P_{k-1}(\xi_0) \sqrt{\xi_0(1-\xi_0)} \end{aligned} \quad (C-28)$$

where $P_{k-1}(\xi_0)$ is a polynomial of degree $(k-1)$ in ξ_0 which satisfies the end conditions

$$\left. \begin{aligned} P_{k-1}(0) &= 1 \\ P_{k-1}(1) &= (-1)^{k-1} \end{aligned} \right\} . \quad (C-29)$$

Therefore, for $k \geq 2$, we get from (C-23)

$$L_{k-1}(\xi_0) = Q_{k-2}(\xi_0) (1-\xi_0) \sqrt{\xi_0(1-\xi_0)} \quad (C-30)$$

where $Q_{k-2}(\xi_0)$ is a polynomial of degree $(k-2)$ in ξ_0 .

We introduce the functions $I(\theta)$, $J(\theta)$, $I_k(\theta)$ and $J_k(\theta)$, $k = 0, 1, 2, \dots$, by means of the integral formulae

$$I(\theta) = \int_0^\theta \left(\frac{\theta_0 \sin \theta_0 - \theta \sin \theta}{\cos \theta_0 - \cos \theta} \right) d\theta_0, \quad (C-31)$$

$$J(\theta) = \int_\theta^\pi \left(\frac{\theta_0 \sin \theta_0 - \theta \sin \theta}{\cos \theta_0 - \cos \theta} \right) d\theta_0, \quad (C-32)$$

$$I_k(\theta) = \int_0^\theta \left(\frac{\cos k\theta_0 - \cos k\theta}{\cos \theta_0 - \cos \theta} \right) d\theta_0, \quad (C-33)$$

and

$$J_k(\theta) = \int_\theta^\pi \left(\frac{\cos k\theta_0 - \cos k\theta}{\cos \theta_0 - \cos \theta} \right) d\theta_0. \quad (C-34)$$

We express ξ in $(0,1)$ in terms of θ in $(0,\pi)$ by means of the formula

$$\xi = \frac{1}{2}(1 - \cos \theta) . \quad (C-35)$$

We next consider ten preliminary integrals. In order to evaluate these integrals we make the change of variable of integration from ξ_0 to θ_0 according to formula (C-9).

$$\begin{aligned}
 (i) \quad & \int_0^\xi \left[\frac{\xi_0}{\xi} \frac{d}{d\xi_0} \left(L_{k-1}(\xi_0) \sqrt{\frac{1-\xi_0}{\xi_0}} \right) - \frac{d}{d\xi} \left(L_{k-1}(\xi) \sqrt{\frac{1-\xi}{\xi}} \right) \sqrt{\frac{\xi(1-\xi)}{\xi_0(1-\xi_0)}} \right] \frac{d\xi_0}{(\xi - \xi_0)} \\
 &= \frac{2}{\xi} \int_0^\theta \left[\left(\sin \frac{\theta_0}{2} \right)^2 \frac{d}{d\theta_0} \left(\frac{\cos(k - \frac{1}{2})\theta}{\sin \frac{1}{2}\theta_0} \right) \right. \\
 &\quad \left. - \left(\sin \frac{\theta}{2} \right)^2 \frac{d}{d\theta} \left(\frac{\cos(k - \frac{1}{2})\theta}{\sin \frac{1}{2}\theta} \right) \right] \frac{d\theta_0}{(\cos \theta_0 - \cos \theta)} \\
 &= \frac{(2k-1)}{\xi} \int_0^\theta \left\{ \sin(k - \frac{1}{2})\theta \sin \frac{1}{2}\theta - \sin(k - \frac{1}{2})\theta_0 \sin \frac{1}{2}\theta_0 \right\} \frac{d\theta_0}{(\cos \theta_0 - \cos \theta)} \\
 &\quad + \frac{1}{\xi} \int_0^\theta \left\{ \cos(k - \frac{1}{2})\theta \cos \frac{1}{2}\theta - \cos(k - \frac{1}{2})\theta_0 \cos \frac{1}{2}\theta_0 \right\} \frac{d\theta_0}{(\cos \theta_0 - \cos \theta)} \\
 &= \frac{(2k-1)}{2\xi} \int_0^\theta \left\{ \cos(k-1)\theta - \cos k\theta - \cos(k-1)\theta_0 + \cos k\theta_0 \right\} \frac{d\theta_0}{(\cos \theta_0 - \cos \theta)} \\
 &\quad + \frac{1}{2\xi} \int_0^\theta \left\{ \cos(k-1)\theta + \cos k\theta - \cos(k-1)\theta_0 - \cos k\theta_0 \right\} \frac{d\theta_0}{(\cos \theta_0 - \cos \theta)} \\
 &= \frac{(2k-1)}{2\xi} \left[I_k(\theta) - I_{k-1}(\theta) \right] - \frac{1}{2\xi} \left[I_k(\theta) + I_{k-1}(\theta) \right] \\
 &= \frac{1}{\xi} \left[(k-1)I_k(\theta) - kI_{k-1}(\theta) \right] . \quad (C-36)
 \end{aligned}$$

$$\begin{aligned}
 \text{(ii)} \quad & \int_{\xi}^1 \left[\frac{\xi_0}{\xi} \frac{d}{d\xi_0} \left(l_{k-1}(\xi_0) \sqrt{\frac{1-\xi_0}{\xi_0}} \right) - \frac{d}{d\xi} \left(l_{k-1}(\xi) \sqrt{\frac{1-\xi}{\xi}} \right) \sqrt{\frac{\xi(1-\xi)}{\xi_0(1-\xi_0)}} \right] \frac{d\xi_0}{(\xi - \xi_0)} \\
 & = \frac{1}{\xi} \left[(k-1)J_k(\theta) - kJ_{k-1}(\theta) \right] \quad . \quad \text{(C-37)}
 \end{aligned}$$

$$\begin{aligned}
 \text{(iii)} \quad & \int_0^{\xi} \left[\frac{1}{\xi} l_{k-1}(\xi_0) \sqrt{\xi_0(1-\xi_0)} - \frac{l_{k-1}(\xi)(1-\xi)}{\sqrt{\xi_0(1-\xi_0)}} \right] \frac{d\xi_0}{(\xi - \xi_0)} \\
 & = \frac{1}{2\xi} \int_0^{\theta} \left[\frac{\cos(k-\frac{1}{2})\theta_0}{\cos \frac{1}{2}\theta_0} (\sin \theta_0)^2 - \frac{\cos(k-\frac{1}{2})\theta}{\cos \frac{1}{2}\theta} (\sin \theta)^2 \right] \frac{d\xi_0}{(\cos \theta_0 - \cos \theta)} \\
 & = \frac{1}{\xi} \int_0^{\theta} \left[\cos(k-\frac{1}{2})\theta_0 \sin \frac{1}{2}\theta_0 \sin \theta_0 \right. \\
 & \quad \left. - \cos(k-\frac{1}{2})\theta \sin \frac{1}{2}\theta \sin \theta \right] \frac{d\theta_0}{(\cos \theta_0 - \cos \theta)} \\
 & = \frac{1}{4\xi} \int_0^{\theta} \left[\cos(k-1)\theta_0 + \cos k\theta_0 - \cos(k-2)\theta_0 - \cos(k+1)\theta_0 - \cos(k-1)\theta \right. \\
 & \quad \left. - \cos k\theta + \cos(k-2)\theta + \cos(k+1)\theta \right] \frac{d\theta_0}{(\cos \theta_0 - \cos \theta)} \\
 & = \frac{1}{4\xi} \left[I_{k-1}(\theta) + I_k(\theta) - I_{k-2}(\theta) - I_{k+1}(\theta) \right] \quad . \quad \text{(C-38)}
 \end{aligned}$$

$$\begin{aligned}
 \text{(iv)} \quad & \int_{\xi}^1 \left[\frac{1}{\xi} l_{k-1}(\xi_0) \sqrt{\xi_0(1-\xi_0)} - \frac{l_{k-1}(\xi)(1-\xi)}{\sqrt{\xi_0(1-\xi_0)}} \right] \frac{d\xi_0}{(\xi - \xi_0)} \\
 & = \frac{1}{4\xi} \left[J_{k-1}(\theta) + J_k(\theta) - J_{k-2}(\theta) - J_{k+1}(\theta) \right] \quad . \quad \text{(C-39)}
 \end{aligned}$$

Note that formulae (C-38) and (C-39) are correct when $k = 1$ even though $I_{-1}(\theta)$ and $J_{-1}(\theta)$ then occur in them.

$$\begin{aligned}
(v) \quad & \int_0^{\xi} \left[L_{k-1}(\xi_0) \sqrt{\frac{1-\xi_0}{\xi_0}} - \frac{L_{k-1}(\xi)(1-\xi)}{\sqrt{\xi_0(1-\xi_0)}} \right] \frac{d\xi_0}{(\xi-\xi_0)} \\
&= 2 \int_0^{\theta} \left[\cos(k-\frac{1}{2})\theta_0 \cos \frac{1}{2}\theta_0 - \cos(k-\frac{1}{2})\theta \cos \frac{1}{2}\theta \right] \frac{d\xi_0}{(\cos \theta_0 - \cos \theta)} \\
&= \int_0^{\theta} \left[\cos(k-1)\theta_0 + \cos k\theta_0 - \cos(k-1)\theta - \cos k\theta \right] \frac{d\theta_0}{(\cos \theta_0 - \cos \theta)} \\
&= I_{k-1}(\theta) + I_k(\theta) \quad . \quad (C-40)
\end{aligned}$$

$$(vi) \quad \int_{\xi}^1 \left[L_{k-1}(\xi_0) \sqrt{\frac{1-\xi_0}{\xi_0}} - \frac{L_{k-1}(\xi)(1-\xi)}{\sqrt{\xi_0(1-\xi_0)}} \right] \frac{d\xi_0}{(\xi-\xi_0)} = J_{k-1}(\theta) + J_k(\theta) \quad . \quad (C-41)$$

$$\begin{aligned}
(vii) \quad & \int_0^{\xi} \left[L_0(\xi_0) - L_0(\xi) \sqrt{\frac{\xi(1-\xi)}{\xi_0(1-\xi_0)}} \right] \frac{d\xi_0}{(\xi-\xi_0)} \\
&= \int_0^{\theta} \left\{ L_0(\xi_0) \sin \theta_0 - L_0(\xi) \sin \theta \right\} \frac{d\theta_0}{(\cos \theta_0 - \cos \theta)} \\
&= \frac{1}{2} \int_0^{\theta} \left(\frac{\theta_0 \sin \theta_0 - \theta \sin \theta}{\cos \theta_0 - \cos \theta} \right) d\theta_0 + \frac{1}{2} \int_0^{\theta} \left(\frac{(\sin \theta_0)^2 - (\sin \theta)^2}{\cos \theta_0 - \cos \theta} \right) d\theta_0 \\
&= \frac{1}{2} I(\theta) - \frac{1}{2} \int_0^{\theta} \left(\frac{\cos 2\theta_0 - \cos 2\theta}{\cos \theta_0 - \cos \theta} \right) d\theta_0 \\
&= \frac{1}{2} I(\theta) - \frac{1}{2} I_2(\theta) \quad . \quad (C-42)
\end{aligned}$$

$$\begin{aligned}
 \text{(viii)} \quad & \int_{\xi}^1 \left[L_0(\xi_0) - L_0(\xi) \sqrt{\frac{\xi(1-\xi)}{\xi_0(1-\xi_0)}} \right] \frac{d\xi_0}{(\xi - \xi_0)} \\
 & = \frac{1}{2} J(\theta) - \frac{1}{2} J_2(\theta) \quad . \quad \text{(C-43)}
 \end{aligned}$$

$$\begin{aligned}
 \text{(ix)} \quad & \int_0^{\xi} \left[L_{k-1}(\xi_0) - L_{k-1}(\xi) \sqrt{\frac{\xi(1-\xi)}{\xi_0(1-\xi_0)}} \right] \frac{d\xi_0}{(\xi - \xi_0)} \\
 & = \int_0^{\theta} [L_{k-1}(\xi_0) \sin \theta_0 - L_{k-1}(\xi) \sin \theta] \frac{d\theta_0}{(\cos \theta_0 - \cos \theta)} \\
 & = \frac{1}{2(k-1)} \int_0^{\theta} [\sin(k-1)\theta_0 \sin \theta_0 - \sin(k-1)\theta \sin \theta] \frac{d\theta_0}{(\cos \theta_0 - \cos \theta)} \\
 & \quad + \frac{1}{2k} \int_0^{\theta} [\sin k\theta_0 \sin \theta_0 - \sin k\theta \sin \theta] \frac{d\theta_0}{(\cos \theta_0 - \cos \theta)} \\
 & = \frac{1}{4(k-1)} \int_0^{\theta} [\cos(k-2)\theta_0 - \cos k\theta_0 - \cos(k-2)\theta + \cos k\theta] \frac{d\theta_0}{(\cos \theta_0 - \cos \theta)} \\
 & \quad + \frac{1}{4k} \int_0^{\theta} [\cos(k-1)\theta_0 - \cos(k+1)\theta_0 - \cos(k-1)\theta + \cos(k+1)\theta] \\
 & \quad \quad \quad \times \frac{d\theta_0}{(\cos \theta_0 - \cos \theta)} \\
 & = \frac{1}{4(k-1)} [I_{k-2}(\theta) - I_k(\theta)] + \frac{1}{4k} [I_{k-1}(\theta) - I_{k+1}(\theta)] \quad , \quad k \geq 2. \quad \text{(C-44)}
 \end{aligned}$$

and

$$(x) \int_{\xi}^1 \left[L_{k-1}(\xi_0) - L_{k-1}(\xi) \sqrt{\frac{\xi(1-\xi)}{\xi_0(1-\xi_0)}} \right] \frac{d\xi_0}{(\xi - \xi_0)}$$

$$= \frac{1}{4(k-1)} [J_{k-2}(\theta) - J_k(\theta)] + \frac{1}{4k} [J_{k-1}(\theta) - J_{k+1}(\theta)], \quad k \geq 2, \quad (C-45)$$

We now substitute from formula (C-13) for $h_r^{(n)}(\xi_0)$ and $h_r^{(n)}(\xi)$ into the integrands of the integrals (C-1) to (C-4) and substitute from formula (C-22) for $k_r^{(n)}(\xi_0)$ and $k_r^{(n)}(\xi)$ into the integrands of the integrals (C-5) and (C-6). The integrals (C-1) to (C-6) may then be expressed as simple combinations of the following integrals which have been re-expressed in simpler terms by using the preliminary integrals (C-36) to (C-45).

$$\int_0^{\xi} \left[\frac{\beta^2 \xi_0}{\xi} \frac{d}{d\xi_0} \left\{ L_{k-1}(\xi_0) \sqrt{\frac{1-\xi_0}{\xi_0}} \exp\left(\frac{i\mu(\xi - \xi_0)}{(1+M)}\right) \right\} \right. \\ \left. - \left\{ \beta^2 \frac{d}{d\xi} \left(L_{k-1}(\xi) \sqrt{\frac{1-\xi}{\xi}} \right) - i\mu(1-M) L_{k-1}(\xi) \sqrt{\frac{1-\xi}{\xi}} \right\} \sqrt{\frac{\xi(1-\xi)}{\xi_0(1-\xi_0)}} \right] \frac{d\xi_0}{(\xi - \xi_0)}$$

$$= \frac{\beta^2}{\xi} \int_0^{\xi} \xi_0 \frac{d}{d\xi_0} \left(L_{k-1}(\xi_0) \sqrt{\frac{1-\xi_0}{\xi_0}} \right) \left\{ \exp\left(\frac{i\mu(\xi - \xi_0)}{(1+M)}\right) - 1 \right\} \frac{d\xi_0}{(\xi - \xi_0)}$$

$$- i\mu \frac{(1-M)}{\xi} \int_0^{\xi} L_{k-1}(\xi_0) \sqrt{\xi_0(1-\xi_0)} \left\{ \exp\left(\frac{i\mu(\xi - \xi_0)}{(1+M)}\right) - 1 \right\} \frac{d\xi_0}{(\xi - \xi_0)}$$

$$+ \beta^2 \int_0^{\xi} \left[\frac{\xi_0}{\xi} \frac{d}{d\xi_0} \left(L_{k-1}(\xi_0) \sqrt{\frac{1-\xi_0}{\xi_0}} \right) - \frac{d}{d\xi} \left(L_{k-1}(\xi) \sqrt{\frac{1-\xi}{\xi}} \right) \sqrt{\frac{\xi(1-\xi)}{\xi_0(1-\xi_0)}} \right] \frac{d\xi_0}{(\xi - \xi_0)}$$

$$- i\mu(1-M) \int_0^{\xi} \left[\frac{1}{\xi} L_{k-1}(\xi_0) \sqrt{\xi_0(1-\xi_0)} - \frac{L_{k-1}(\xi)(1-\xi)}{\sqrt{\xi_0(1-\xi_0)}} \right] \frac{d\xi_0}{(\xi - \xi_0)}$$

$$\begin{aligned}
&= \frac{\beta^2}{\xi} \int_0^{\xi} \xi_0 \frac{d}{d\xi_0} \left(\rho_{k-1}(\xi_0) \sqrt{\frac{1-\xi_0}{\xi_0}} \right) \left\{ \exp\left(\frac{i\mu(\xi-\xi_0)}{(1+M)}\right) - 1 \right\} \frac{d\xi_0}{(\xi-\xi_0)} \\
&\quad - \frac{i\mu(1-M)}{\xi} \int_0^{\xi} \rho_{k-1}(\xi_0) \sqrt{\xi_0(1-\xi_0)} \left\{ \exp\left(\frac{i\mu(\xi-\xi_0)}{(1+M)}\right) - 1 \right\} \frac{d\xi_0}{(\xi-\xi_0)} \\
&\quad - \frac{\beta^2}{\xi} [kI_{k-1}(\theta) - (k-1)I_k(\theta)] \\
&\quad + \frac{i\mu(1-M)}{4\xi} [I_{k-2}(\theta) - I_{k-1}(\theta) - I_k(\theta) + I_{k+1}(\theta)] \quad . \quad (C-46)
\end{aligned}$$

$$\begin{aligned}
&\int_{\xi}^1 \left[\frac{\beta^2 \xi_0}{\xi} \frac{d}{d\xi_0} \left\{ \rho_{k-1}(\xi_0) \sqrt{\frac{1-\xi_0}{\xi_0}} \exp\left(\frac{i\mu(\xi-\xi_0)}{(1-M)}\right) \right\} \right. \\
&\quad \left. - \left\{ \beta^2 \frac{d}{d\xi} \left(\rho_{k-1}(\xi) \sqrt{\frac{1-\xi}{\xi}} \right) - i\mu(1+M) \rho_{k-1}(\xi) \sqrt{\frac{1-\xi}{\xi}} \right\} \sqrt{\frac{\xi(1-\xi)}{\xi_0(1-\xi_0)}} \frac{d\xi_0}{(\xi-\xi_0)} \right] \\
&= \frac{\beta^2}{\xi} \int_{\xi}^1 \xi_0 \frac{d}{d\xi_0} \left(\rho_{k-1}(\xi_0) \sqrt{\frac{1-\xi_0}{\xi_0}} \right) \left\{ \exp\left(\frac{i\mu(\xi-\xi_0)}{(1-M)}\right) - 1 \right\} \frac{d\xi_0}{(\xi-\xi_0)} \\
&\quad - \frac{i\mu(1+M)}{\xi} \int_{\xi}^1 \rho_{k-1}(\xi_0) \sqrt{\xi_0(1-\xi_0)} \left\{ \exp\left(\frac{i\mu(\xi-\xi_0)}{(1-M)}\right) - 1 \right\} \frac{d\xi_0}{(\xi-\xi_0)} \\
&\quad + \beta^2 \int_{\xi}^1 \left[\frac{\xi_0}{\xi} \frac{d}{d\xi_0} \left(\rho_{k-1}(\xi_0) \sqrt{\frac{1-\xi_0}{\xi_0}} \right) - \frac{d}{d\xi} \left(\rho_{k-1}(\xi) \sqrt{\frac{1-\xi}{\xi}} \right) \sqrt{\frac{\xi(1-\xi)}{\xi_0(1-\xi_0)}} \right] \frac{d\xi_0}{(\xi-\xi_0)} \\
&\quad - i\mu(1+M) \int_{\xi}^1 \left[\frac{1}{\xi} \rho_{k-1}(\xi_0) \sqrt{\xi_0(1-\xi_0)} - \frac{\rho_{k-1}(\xi)(1-\xi)}{\sqrt{\xi_0(1-\xi_0)}} \right] \frac{d\xi_0}{(\xi-\xi_0)}
\end{aligned}$$

$$\begin{aligned}
&= \frac{\beta^2}{\xi} \int_{\xi}^1 \xi_0 \frac{d}{d\xi_0} \left(\lambda_{k-1}(\xi_0) \sqrt{\frac{1-\xi_0}{\xi_0}} \right) \left\{ \exp\left(\frac{i\mu(\xi-\xi_0)}{(1-M)}\right) - 1 \right\} \frac{d\xi_0}{(\xi-\xi_0)} \\
&\quad - \frac{i\mu(1+M)}{\xi} \int_{\xi}^1 \lambda_{k-1}(\xi_0) \sqrt{\xi_0(1-\xi_0)} \left\{ \exp\left(\frac{i\mu(\xi-\xi_0)}{(1-M)}\right) - 1 \right\} \frac{d\xi_0}{(\xi-\xi_0)} \\
&\quad - \frac{\beta^2}{\xi} [kJ_{k-1}(\theta) - (k-1)J_k(\theta)] \\
&\quad + \frac{i\mu(1+M)}{4\xi} [J_{k-2}(\theta) - J_{k-1}(\theta) - J_k(\theta) + J_{k+1}(\theta)] \quad . \quad (C-47)
\end{aligned}$$

$$\begin{aligned}
&\int_0^{\xi} \left[\lambda_{k-1}(\xi_0) \sqrt{\frac{1-\xi_0}{\xi_0}} \exp\left(\frac{i\mu(\xi-\xi_0)}{(1+M)}\right) - \frac{\lambda_{k-1}(\xi)(1-\xi)}{\sqrt{\xi_0(1-\xi_0)}} \right] \frac{d\xi_0}{(\xi-\xi_0)} \\
&= \int_0^{\xi} \lambda_{k-1}(\xi_0) \sqrt{\frac{1-\xi_0}{\xi_0}} \left\{ \exp\left(\frac{i\mu(\xi-\xi_0)}{(1+M)}\right) - 1 \right\} \frac{d\xi_0}{(\xi-\xi_0)} \\
&\quad + \int_0^{\xi} \left[\lambda_{k-1}(\xi_0) \sqrt{\frac{1-\xi_0}{\xi_0}} - \frac{\lambda_{k-1}(\xi)(1-\xi)}{\sqrt{\xi_0(1-\xi_0)}} \right] \frac{d\xi_0}{(\xi-\xi_0)} \\
&= \int_0^{\xi} \lambda_{k-1}(\xi_0) \sqrt{\frac{1-\xi_0}{\xi_0}} \left\{ \exp\left(\frac{i\mu(\xi-\xi_0)}{(1+M)}\right) - 1 \right\} \frac{d\xi_0}{(\xi-\xi_0)} \\
&\quad + I_{k-1}(\theta) + I_k(\theta) \quad . \quad (C-48)
\end{aligned}$$

$$\begin{aligned}
& \int_{\xi}^1 \left[l_{k-1}(\xi_0) \sqrt{\frac{1-\xi_0}{\xi_0}} \exp\left(\frac{i\mu(\xi-\xi_0)}{(1-M)}\right) - \frac{l_{k-1}(\xi)(1-\xi)}{\sqrt{\xi_0(1-\xi_0)}} \right] \frac{d\xi_0}{(\xi-\xi_0)} \\
&= \int_{\xi}^1 l_{k-1}(\xi_0) \sqrt{\frac{1-\xi_0}{\xi_0}} \left\{ \exp\left(\frac{i\mu(\xi-\xi_0)}{(1-M)}\right) - 1 \right\} \frac{d\xi_0}{(\xi-\xi_0)} \\
&+ \int_{\xi}^1 \left[l_{k-1}(\xi_0) \sqrt{\frac{1-\xi_0}{\xi_0}} - \frac{l_{k-1}(\xi)(1-\xi)}{\sqrt{\xi_0(1-\xi_0)}} \right] \frac{d\xi_0}{(\xi-\xi_0)} \\
&= \int_{\xi}^1 l_{k-1}(\xi_0) \sqrt{\frac{1-\xi_0}{\xi_0}} \left\{ \exp\left(\frac{i\mu(\xi-\xi_0)}{(1-M)}\right) - 1 \right\} \frac{d\xi_0}{(\xi-\xi_0)} \\
&+ J_{k-1}(\theta) + J_k(\theta) . \tag{C-49}
\end{aligned}$$

$$\begin{aligned}
& \int_0^{\xi} \left[L_{k-1}(\xi_0) \exp\left(\frac{i\mu(\xi-\xi_0)}{(1+M)}\right) - L_{k-1}(\xi) \sqrt{\frac{\xi(1-\xi)}{\xi_0(1-\xi_0)}} \right] \frac{d\xi_0}{(\xi-\xi_0)} \\
&= \int_0^{\xi} L_{k-1}(\xi_0) \left\{ \exp\left(\frac{i\mu(\xi-\xi_0)}{(1+M)}\right) - 1 \right\} \frac{d\xi_0}{(\xi-\xi_0)} \\
&+ \int_0^{\xi} \left[L_{k-1}(\xi_0) - L_{k-1}(\xi) \sqrt{\frac{\xi(1-\xi)}{\xi_0(1-\xi_0)}} \right] \frac{d\xi_0}{(\xi-\xi_0)} \\
&= \begin{cases} \int_0^{\xi} L_0(\xi_0) \left\{ \exp\left(\frac{i\mu(\xi-\xi_0)}{(1+M)}\right) - 1 \right\} \frac{d\xi_0}{(\xi-\xi_0)} + \frac{1}{2}I(\theta) - \frac{1}{2}J_2(\theta) , & k=1 \\ \int_0^{\xi} L_{k-1}(\xi_0) \left\{ \exp\left(\frac{i\mu(\xi-\xi_0)}{(1+M)}\right) - 1 \right\} \frac{d\xi_0}{(\xi-\xi_0)} \\ + \frac{1}{4(k-1)} [L_{k-2}(\theta) - L_k(\theta)] + \frac{1}{4k} [L_{k-1}(\theta) - L_{k+1}(\theta)] , & k > 2. \end{cases} \tag{C-50}
\end{aligned}$$

$$\begin{aligned}
& \int_{\xi}^1 \left[L_{k-1}(\xi_0) \exp\left(\frac{i\mu(\xi - \xi_0)}{1-M}\right) - L_{k-1}(\xi) \sqrt{\frac{\xi(1-\xi)}{\xi_0(1-\xi_0)}} \right] \frac{d\xi_0}{(\xi - \xi_0)} \\
&= \int_{\xi}^1 L_{k-1}(\xi_0) \left\{ \exp\left(\frac{i\mu(\xi - \xi_0)}{1-M}\right) - 1 \right\} \frac{d\xi_0}{(\xi - \xi_0)} \\
&+ \int_{\xi}^1 \left[L_{k-1}(\xi_0) - L_{k-1}(\xi) \sqrt{\frac{\xi(1-\xi)}{\xi_0(1-\xi_0)}} \right] \frac{d\xi_0}{(\xi - \xi_0)} \\
&= \begin{cases} \int_{\xi}^1 L_0(\xi_0) \left\{ \exp\left(\frac{i\mu(\xi - \xi_0)}{1-M}\right) - 1 \right\} \frac{d\xi_0}{(\xi - \xi_0)} + \frac{1}{2}J(\theta) - \frac{1}{2}J_2(\theta) , & k = 1, \\ \int_{\xi}^1 L_{k-1}(\xi_0) \left\{ \exp\left(\frac{i\mu(\xi - \xi_0)}{1-M}\right) - 1 \right\} \frac{d\xi_0}{(\xi - \xi_0)} \\ + \frac{1}{4(k-1)} [J_{k-2}(\theta) - J_k(\theta)] + \frac{1}{4k} [J_{k-1}(\theta) - J_{k+1}(\theta)] , & k \geq 2. \end{cases} \quad (C-51)
\end{aligned}$$

The integrals on the right-hand sides of formulae (C-46) to (C-51) have to be evaluated numerically and so also must the values of $I(\theta)$, $J(\theta)$, $I_k(\theta)$ and $J_k(\theta)$, $k = -1(1)n+1$. We shall first discuss the numerical evaluation of the said integrals, then the evaluation of $I_k(\theta)$ and $J_k(\theta)$ and finally the evaluation of $I(\theta)$ and $J(\theta)$.

In the numerical evaluation of the integrals the function $E(x)$ defined by

$$\begin{aligned}
E(x) &= \frac{(\exp(ix) - 1)}{ix} \\
&= \frac{\sin x}{x} + i\left(\frac{1 - \cos x}{x}\right) \quad (C-52)
\end{aligned}$$

has to be evaluated for a large number of values of x . If $|x| > 1$ we evaluate $\sin x$ and $\cos x$ and insert their values into formula (C-52) in order to get the value of $E(x)$. If $|x| < 1$ we use the Chebyshev expansions

$$\frac{1 - \cos x}{x} = \frac{1}{2}x \sum_{r=0}^{\infty} A_r(1) T_{2r}(x) \quad -1 < x < 1 \quad (C-53)$$

and

$$\frac{\sin x}{x} = \sum_{r=0}^{\infty} B_r(1) T_{2r}(x) \quad -1 < x < 1 \quad (C-54)$$

to get $E(x)$ from formula (C-52). The dash ' on the summation signs \sum in formulae (C-53) and (C-54) is used to indicate that the $r = 0$ term must be multiplied by $\frac{1}{2}$ before being summed. The Chebyshev polynomial $T_r(x)$ is a polynomial of degree r in x given by the formula

$$T_r(x) = \cos(r \cos^{-1} x) \quad -1 < x < 1. \quad (C-55)$$

The expansions (C-53) and (C-54) are useful when $|x|$ is small. The coefficients $A_r(1)$ and $B_r(1)$ in the formulae (C-53) and (C-54) have been determined numerically for $r = 0, 1, 2, \dots$, by applying the method of Clenshaw¹⁵, and were found to be

| | |
|---------------------------|---------------------------|
| $A_0(1) = 1.91871929738$ | $B_0(1) = 1.83946082018$ |
| $A_1(1) = -0.04030078984$ | $B_1(1) = -0.07925847720$ |
| $A_2(1) = 0.00033804122$ | $B_2(1) = 0.00100506127$ |
| $A_3(1) = -0.00000151602$ | $B_3(1) = -0.00000603035$ |
| $A_4(1) = 0.00000000423$ | $B_4(1) = 0.00000002104$ |
| $A_5(1) = -0.00000000001$ | $B_5(1) = -0.00000000005$ |
| $A_6(1) = 0.00000000000$ | $B_6(1) = 0.00000000000$ |

(C-56)

We write

$$\begin{aligned} & \frac{\beta^2}{\xi} \int_0^{\xi} \epsilon_0 \frac{d}{d\epsilon_0} \left(\rho_{k-1}(\epsilon_0) \sqrt{\frac{1-\epsilon_0}{\epsilon_0}} \right) \left\{ \exp\left(\frac{i\mu(\xi-\epsilon_0)}{(1+M)}\right) - 1 \right\} \frac{d\epsilon_0}{(\xi-\epsilon_0)} \\ & = \frac{i\mu(1-M)}{\xi} \int_0^{\xi} \epsilon_0 \frac{d}{d\epsilon_0} \left(\rho_{k-1}(\epsilon_0) \sqrt{\frac{1-\epsilon_0}{\epsilon_0}} \right) E\left(\frac{\mu(\xi-\epsilon_0)}{(1+M)}\right) d\epsilon_0. \quad (C-57) \end{aligned}$$

The interval $(0, \xi)$ of integration is divided into one or more subintervals of integration to cope with any waviness in the integrand. The integrand in the integral (C-57) behaves like $1/\sqrt{\xi_0}$ for ξ_0 near to zero and like $1/\sqrt{1-\xi_0}$ for ξ_0 near to unity. We accordingly evaluate the integral by using Gaussian numerical integration with weight function $1/\sqrt{\xi_0}$ over the subinterval abutting on $\xi_0 = 0$ and by using Gaussian numerical integration with weight function 1 over any other subintervals, if they exist, except that when ξ is very close to unity the last subinterval is extended up to unity and compensated by subtracting an integral over $(\xi, 1)$. The integration over these subintervals abutting on $\xi_0 = 1$ are carried out by using Gaussian numerical integration with weight function $1/\sqrt{1-\xi_0}$. A fairly small number of integration points is used in each subinterval.

We write

$$\begin{aligned} & \frac{i\mu(1-M)}{\xi} \int_0^{\xi} L_{k-1}(\xi_0) \sqrt{\xi_0(1-\xi_0)} \left\{ \exp\left(\frac{i\mu(\xi-\xi_0)}{(1+M)}\right) - 1 \right\} \frac{d\xi_0}{(\xi-\xi_0)} \\ &= \frac{(i\mu)^2}{\xi} \frac{(1-M)}{(1+M)} \int_0^{\xi} L_{k-1}(\xi_0) \sqrt{\xi_0(1-\xi_0)} E\left(\frac{\mu(\xi-\xi_0)}{(1+M)}\right) d\xi_0 . \end{aligned} \quad \dots\dots (C-58)$$

The integrand in the integral (C-58) behaves like $\sqrt{\xi_0}$ for ξ_0 near to zero and like $\sqrt{1-\xi_0}$ for ξ_0 near to unity. However, we evaluate the integral (C-58) in exactly the same manner as we evaluated the integral (C-57) even though the behaviours of the integrand for ξ_0 near to zero and near to unity are now different. A small increase in accuracy would result by taking the actual $\sqrt{\xi_0}$ and $\sqrt{1-\xi_0}$ behaviours into account in the Gaussian numerical integration but we would then lose the advantage of keeping the location of the integration points unchanged.

We write

$$\begin{aligned} & \int_0^{\xi} L_{k-1}(\xi_0) \sqrt{\frac{1-\xi_0}{\xi_0}} \left\{ \exp\left(\frac{i\mu(\xi-\xi_0)}{(1+M)}\right) - 1 \right\} \frac{d\xi_0}{(\xi-\xi_0)} \\ &= \frac{i\mu}{(1+M)} \int_0^{\xi} L_{k-1}(\xi_0) \sqrt{\frac{1-\xi_0}{\xi_0}} E\left(\frac{\mu(\xi-\xi_0)}{(1+M)}\right) d\xi_0 . \end{aligned} \quad (C-59)$$

The integrand in the integral (C-59) behaves like $1/\sqrt{\xi_0}$ for ξ_0 near to zero and like $\sqrt{1-\xi_0}$ for ξ_0 near to unity, but again we evaluate the integral (C-59) in exactly the same manner as we evaluated the integral (C-57).

We write

$$\int_0^{\xi} L_{k-1}(\xi_0) \left\{ \exp\left(\frac{i\mu(\xi - \xi_0)}{(1+M)}\right) - 1 \right\} \frac{d\xi_0}{(\xi - \xi_0)}$$

$$= \frac{i\mu}{(1+M)} \int_0^{\xi} L_{k-1}(\xi_0) E\left(\frac{\mu(\xi - \xi_0)}{(1+M)}\right) d\xi_0 \quad (C-60)$$

From formulae (C-27) and (C-30) we see that the integrand in the integral (C-60) behaves like $\sqrt{\xi_0}$ for ξ_0 near to zero when $k \geq 1$ and like $(1-\xi_0)^{\frac{1}{2}}$ for ξ_0 near to unity when $k \geq 2$. When $k = 1$ we see from formula (C-27) that $L_0(\xi_0) - \frac{1}{2}\pi$ behaves like $(1-\xi_0)^{\frac{1}{2}}$ for ξ_0 near to unity. We still evaluate the integral (C-60) when $k \geq 2$ in exactly the same manner as we evaluated the integral (C-57), but when $k = 1$ we must modify the integration procedure over subintervals abutting on $\xi_0 = 1$ to take into account the behaviour of $L_0(\xi_0)$ as the sum of a known constant and a function which behaves like $(1-\xi_0)^{\frac{1}{2}}$. This procedure will inevitably lead to new sets of integration points for evaluating the integral involving the constant contribution to $L_0(\xi_0)$ over those subintervals abutting on $\xi_0 = 1$.

We write

$$\frac{\beta^2}{\xi} \int_{\xi}^1 \xi_0 \frac{d}{d\xi_0} \left(L_{k-1}(\xi_0) \sqrt{\frac{1-\xi_0}{\xi_0}} \right) \left\{ \exp\left(\frac{i\mu(\xi - \xi_0)}{(1-M)}\right) - 1 \right\} \frac{d\xi_0}{(\xi - \xi_0)}$$

$$= \frac{i\mu(1+M)}{\xi} \int_{\xi}^1 \xi_0 \frac{d}{d\xi_0} \left(L_{k-1}(\xi_0) \sqrt{\frac{1-\xi_0}{\xi_0}} \right) E\left(\frac{\mu(\xi - \xi_0)}{(1-M)}\right) d\xi_0 \quad (C-61)$$

The interval $(\xi, 1)$ of integration is divided into one or more subintervals of integration to cope with any waviness in the integrand. The integrand in the integral (C-61) behaves like $1/\sqrt{\xi_0}$ for ξ_0 near to zero and like $1/\sqrt{1-\xi_0}$ for ξ_0 near to unity. We accordingly evaluate the integral by using Gaussian

numerical integration with weight function $1/\sqrt{1-\xi_0}$ over the subinterval abutting on $\xi_0 = 1$ and by using Gaussian numerical integration with weight function 1 over any other subintervals, if they exist, except that when ξ is very close to zero the last subinterval is extended down to zero and compensated by subtracting an integral over $(0, \xi)$. The integration over these subintervals abutting on $\xi_0 = 0$ are carried out by using Gaussian numerical integration with weight function $1/\sqrt{\xi_0}$. A fairly small number of integration points is used in each subinterval.

We write

$$\begin{aligned} \frac{i\mu(1+M)}{\xi} \int_{\xi}^1 L_{k-1}(\xi_0) \sqrt{\xi_0(1-\xi_0)} \left\{ \exp\left(\frac{i\mu(\xi-\xi_0)}{(1-M)}\right) - 1 \right\} \frac{d\xi_0}{(\xi-\xi_0)} \\ = \frac{(i\mu)^2}{\xi} \frac{(1+M)}{(1-M)} \int_{\xi}^1 L_{k-1}(\xi_0) \sqrt{\xi_0(1-\xi_0)} E\left(\frac{\mu(\xi-\xi_0)}{(1-M)}\right) d\xi_0, \end{aligned} \quad (C-62)$$

$$\begin{aligned} \int_{\xi}^1 L_{k-1}(\xi_0) \sqrt{\frac{1-\xi_0}{\xi_0}} \left\{ \exp\left(\frac{i\mu(\xi-\xi_0)}{(1-M)}\right) - 1 \right\} \frac{d\xi_0}{(\xi-\xi_0)} \\ = \frac{i\mu}{(1-M)} \int_{\xi}^1 L_{k-1}(\xi_0) \sqrt{\frac{1-\xi_0}{\xi_0}} E\left(\frac{\mu(\xi-\xi_0)}{(1-M)}\right) d\xi_0, \end{aligned} \quad (C-63)$$

and

$$\begin{aligned} \int_{\xi}^1 L_{k-1}(\xi_0) \left\{ \exp\left(\frac{i\mu(\xi-\xi_0)}{(1-M)}\right) - 1 \right\} \frac{d\xi_0}{(\xi-\xi_0)} \\ = \frac{i\mu}{(1-M)} \int_{\xi}^1 L_{k-1}(\xi_0) E\left(\frac{\mu(\xi-\xi_0)}{(1-M)}\right) d\xi_0. \end{aligned} \quad (C-64)$$

We evaluate the integrals (C-62), (C-63) and (C-64) in the same manner as we evaluated the integral (C-61) except that for $k = 1$ the evaluation of (C-64) has to be modified over a subinterval abutting on $\xi_0 = 1$ in the same manner as the evaluation of (C-60) was modified over a subinterval abutting on $\xi_0 = 1$.

It is possible to give explicit formulae for the functions $I_k(\theta)$ and $J_k(\theta)$ defined by formulae (C-33) and (C-34) but it is simpler to get their values for $k \geq 2$ from the recurrence relations

$$I_{k+1}(\theta) + I_{k-1}(\theta) - 2 \cos \theta I_k(\theta) = \begin{cases} 2\theta & k = 0 \\ \frac{2}{k} \sin k\theta & k \neq 0 \end{cases} \quad (\text{C-65})$$

and

$$J_{k+1}(\theta) + J_{k-1}(\theta) - 2 \cos \theta J_k(\theta) = \begin{cases} 2(\pi - \theta) & k = 0 \\ -\frac{2}{k} \sin k\theta & k \neq 0 \end{cases} \quad (\text{C-66})$$

and the starting functions

$$I_0(\theta) = 0 \quad (\text{C-67})$$

$$I_1(\theta) = \theta \quad (\text{C-68})$$

$$J_0(\theta) = 0 \quad (\text{C-69})$$

$$J_1(\theta) = \pi - \theta \quad (\text{C-70})$$

Finally we show how to evaluate $I(\theta)$ and $J(\theta)$ defined by the formulae (C-31) and (C-32). First we note that

$$\begin{aligned} I(\theta) + J(\theta) &= \int_0^\pi \left(\frac{\theta_0 \sin \theta_0 - \theta \sin \theta}{\cos \theta_0 - \cos \theta} \right) d\theta_0 \\ &= -\frac{1}{2} \int_0^\pi \frac{d}{d\theta_0} \left\{ \theta_0 \log(\cos \theta_0 - \cos \theta)^2 + \theta \log \left(\frac{1 - \cos(\theta + \theta_0)}{1 - \cos(\theta - \theta_0)} \right) \right\} d\theta_0 \\ &\quad + \frac{1}{2} \int_0^\pi \log(\cos \theta_0 - \cos \theta)^2 d\theta_0 \end{aligned}$$

$$\begin{aligned}
&= - \frac{1}{2} \left[\theta_0 \log(\cos \theta_0 - \cos \theta)^2 + \theta \log \left(\frac{1 - \cos(\theta + \theta_0)}{1 - \cos(\theta - \theta_0)} \right) \right]_0^\pi \\
&\quad - \pi \log 2 \\
&= - \pi \log(2 + 2 \cos \theta) \quad . \quad (C-71)
\end{aligned}$$

Hence

$$J(\theta) = - I(\theta) - \pi \log(2 + 2 \cos \theta) \quad . \quad (C-72)$$

We show in Appendix D that $I(\theta)$ can be expressed for $-\pi < \theta < \pi$ by means of the formula involving an expansion in terms of Chebyshev polynomials

$$I(\theta) = 2\pi \log \left(\frac{\pi + \theta}{\pi - \theta} \right) - 2\theta \sum_{r=0}^{\infty} e_r T_{2r} \left(\frac{\theta}{\pi} \right) \quad (C-73)$$

where the dash ' on the summation sign \sum is used to indicate that the $r = 0$ term must be multiplied by $\frac{1}{2}$ before being summed and the Chebyshev polynomial $T_r(x)$ is a polynomial of degree r in x given by formula (C-55). The coefficients e_r in formula (C-73) may be determined numerically for $r = 0, 1, 2, \dots$, by applying the method of Clenshaw¹⁵ as described in Appendix D. The values of the coefficients e_r , $r = 0, 1, 2, \dots$, turn out to be

$$\begin{aligned}
e_0 &= 5.54164409617 \\
e_1 &= -0.23425441323 \\
e_2 &= -0.00529755306 \\
e_3 &= -0.00023275109 \\
e_4 &= -0.00001232864 \\
e_5 &= -0.00000070953 \\
e_6 &= -0.00000004273 \\
e_7 &= -0.00000000265 \\
e_8 &= -0.00000000017 \\
e_9 &= -0.00000000001 \\
e_{10} &= -0.00000000000
\end{aligned} \quad (C-74)$$

The procedure for obtaining the numerical values of the integrals (C-1) to (C-6) is first to obtain the numerical values of the integrals (C-46) to (C-51) and then to combine them linearly following the formulae (C-13) and (C-22). The integrals (C-46) to (C-51) are obtained in terms of integrals that can be evaluated using Gaussian numerical integration techniques and in terms of the functions $I(\theta)$, $J(\theta)$, $I_k(\theta)$ and $J_k(\theta)$, $k = -1(1)n+1$.

Appendix D

EXPRESSION OF $I(\theta)$ IN TERMS OF CHEBYSHEV POLYNOMIALS

The function $I(\theta)$ is defined in formula (C-31) of Appendix C and is

$$I(\theta) = \int_0^\theta \left(\frac{\theta_0 \sin \theta_0 - \theta \sin \theta}{\cos \theta_0 - \cos \theta} \right) d\theta_0 \quad (D-1)$$

On differentiation of formula (D-1) with respect to θ we get

$$\begin{aligned} \frac{dI(\theta)}{d\theta} &= \lim_{\theta_0 \rightarrow 0} \left(\frac{\theta_0 \sin \theta_0 - \theta \sin \theta}{\cos \theta_0 - \cos \theta} \right) + \int_0^\theta \frac{d}{d\theta} \left(\frac{\theta_0 \sin \theta_0 - \theta \sin \theta}{\cos \theta_0 - \cos \theta} \right) d\theta_0 \\ &= - \left(1 + \frac{\theta \cos \theta}{\sin \theta} \right) - \int_0^\theta \left[\left(\frac{\sin \theta + \theta \cos \theta}{\cos \theta_0 - \cos \theta} \right) + \frac{(\theta_0 \sin \theta_0 - \theta \sin \theta) \sin \theta}{(\cos \theta_0 - \cos \theta)^2} \right] d\theta_0 \\ &= - \left(1 + \frac{\theta \cos \theta}{\sin \theta} \right) - \lim_{\delta \rightarrow 0} \left[\int_0^{\theta-\delta} \left\{ \left(\frac{\sin \theta + \theta \cos \theta}{\cos \theta_0 - \cos \theta} \right) - \frac{\theta (\sin \theta)^2}{(\cos \theta_0 - \cos \theta)^2} \right\} d\theta_0 \right. \\ &\quad \left. + \sin \theta \int_0^{\theta-\delta} \theta_0 \frac{d}{d\theta_0} \left(\frac{1}{\cos \theta_0 - \cos \theta} \right) d\theta_0 \right] \\ &= - \left(1 + \frac{\theta \cos \theta}{\sin \theta} \right) - \lim_{\delta \rightarrow 0} \left[\int_0^{\theta-\delta} \left\{ \frac{\theta \cos \theta}{(\cos \theta_0 - \cos \theta)} - \frac{\theta (\sin \theta)^2}{(\cos \theta_0 - \cos \theta)^2} \right\} d\theta_0 \right. \\ &\quad \left. + \left[\frac{\theta_0 \sin \theta}{\cos \theta_0 - \cos \theta} \right]_{\theta_0=0}^{\theta_0=\theta-\delta} \right] \end{aligned}$$

$$\begin{aligned}
&= - \left(1 + \frac{\theta \cos \theta}{\sin \theta} \right) + \lim_{\delta \rightarrow 0} \left\{ \left[\frac{\theta \sin \theta_0}{(\cos \theta_0 - \cos \theta)} - \frac{\theta_0 \sin \theta}{(\cos \theta_0 - \cos \theta)} \right]_{\theta_0=0}^{\theta_0=\theta-\delta} \right\} \\
&= - 2\theta \frac{\cos \theta}{\sin \theta} . \tag{D-2}
\end{aligned}$$

From formula (D-1) we get

$$I(0) = 0 . \tag{D-3}$$

Hence, on integration of formula (D-2), taking note of the value (D-3), we get

$$I(\theta) = - 2 \int_0^\theta \frac{\theta_0 \cos \theta_0}{\sin \theta_0} d\theta_0 \tag{D-4}$$

which is a more convenient formula for our present purpose than is formula (D-1).

Let us write

$$z = \frac{\theta}{\pi} , \tag{D-5}$$

$$f(z) = \frac{\sin \theta}{\theta} , \tag{D-6}$$

$$g(z) = \cos \theta . \tag{D-7}$$

The functions $f(z)$ and $g(z)$ are even functions of z . The function $f(z)$ has simple zeros at $z = \pm 1$ and no other zeros in $-1 < z < 1$. Therefore we may write

$$f(z) = (1 - z^2)k(z) \tag{D-8}$$

where $k(z)$ is an even function of z which has no zeros in $-1 < z < 1$.

From formulae (D-6) and (D-8) we get

$$\begin{aligned}
 k(1) &= \lim_{z \rightarrow 1} \frac{f(z)}{(1-z^2)} \\
 &= \lim_{\theta \rightarrow \pi} \left\{ \frac{\sin \theta}{\theta} \frac{\pi^2}{\pi^2 - \theta^2} \right\} \\
 &= \frac{1}{2} .
 \end{aligned} \tag{D-9}$$

From formula (D-7) we get

$$\begin{aligned}
 g(1) &= \cos \pi \\
 &= -1 .
 \end{aligned} \tag{D-10}$$

Hence

$$\begin{aligned}
 \frac{\theta \cos \theta}{\sin \theta} &= \frac{g(z)}{f(z)} \\
 &= \frac{g(z)}{(1-z^2)k(z)} \\
 &= \frac{g(1)}{k(1)} \frac{1}{(1-z^2)} + \left\{ \frac{g(z)}{k(z)} - \frac{g(1)}{k(1)} \right\} \frac{1}{(1-z^2)} \\
 &= -\frac{2}{(1-z^2)} + h(z) ,
 \end{aligned} \tag{D-11}$$

where $h(z)$ is the even function of z given by

$$h(z) = \left\{ \frac{g(z)}{k(z)} + 2 \right\} \frac{1}{(1-z^2)} . \tag{D-12}$$

If we make the substitution

$$z_0 = \frac{\theta_0}{\pi} \tag{D-13}$$

in the integrand of the integral on the right-hand side of formula (D-4), and use the expression (D-11), we get

$$\begin{aligned}
 I(\theta) &= -2\pi \int_0^z \left\{ -\frac{2}{(1-z_0^2)} + h(z_0) \right\} dz_0 \\
 &= 2\pi \log\left(\frac{1+z}{1-z}\right) - 2\pi z H(z)
 \end{aligned} \tag{D-14}$$

where

$$H(z) = \frac{1}{z} \int_0^z h(z_0) dz_0 \tag{D-15}$$

is an even function of z .

We may write for $H(z)$ the expansion in terms of Chebyshev polynomials

$$H(z) = \sum_{r=0}^{\infty} e_r T_{2r}(z) \quad -1 < z < 1. \tag{D-16}$$

where the dash ' on the summation sign \sum is used to indicate that the $r = 0$ term must be multiplied by $\frac{1}{2}$ before being summed and the Chebyshev polynomial $T_r(x)$ is a polynomial of degree r in x given by formula (C-55) of Appendix C. We need to determine the coefficients e_r , $r = 0, 1, 2, \dots$, in order to evaluate $H(z)$ for use in formula (D-14).

In the process of determining the coefficients e_r , $r = 0, 1, 2, \dots$, we need to determine the coefficients a_r, b_r, c_r, d_r , $r = 0, 1, 2, \dots$, of the expansions

$$f(z) = \sum_{r=0}^{\infty} a_r T_{2r}(z) \quad -1 < z < 1 \tag{D-17}$$

$$g(z) = \sum_{r=0}^{\infty} b_r T_{2r}(z) \quad -1 < z < 1 \tag{D-18}$$

$$h(z) = \sum_{r=0}^{\infty} c_r T_{2r}(z) \quad -1 < z < 1 \tag{D-19}$$

and

$$k(z) = \sum_{r=0}^{\infty} d_r T_{2r}(z) \quad -1 \leq z \leq 1. \quad (D-20)$$

We also need to introduce the even function $l(z)$ of z given by the formula

$$l(z) = \frac{g(z) + 2k(z)}{1 - z^2} \quad (D-21)$$

and determine the coefficients l_r , $r = 0, 1, 2, \dots$, of the expansion

$$l(z) = \sum_{r=0}^{\infty} l_r T_{2r}(z) \quad -1 \leq z \leq 1. \quad (D-22)$$

We obtain the coefficients a_r , b_r by considering the differential equations that $f(z)$ and $g(z)$ satisfy. The coefficients d_r are obtained in terms of the coefficients a_r by using the formula (D-8). The coefficients l_r are obtained in terms of the coefficients b_r and d_r by using formula (D-21). The coefficients c_r are obtained in terms of the coefficients d_r and l_r by using the formula

$$h(z) = \frac{l(z)}{k(z)}. \quad (D-23)$$

The coefficients e_r are then obtained in terms of the coefficients c_r by using the formula (D-15).

We start by obtaining the coefficients a_r and b_r in formulae (D-17) and (D-18) for $f(z)$ and $g(z)$. The functions $f(z)$ and $g(z)$ of formulae (D-6) and (D-7) satisfy the pair of simultaneous linear differential equations

$$z \frac{df(z)}{dz} + f(z) - g(z) = 0 \quad (D-24)$$

$$\frac{dg(z)}{dz} + \pi^2 z f(z) = 0. \quad (D-25)$$

We seek approximations $f^{(a)}(z)$ and $g^{(a)}(z)$ to the functions $f(z)$ and $g(z)$ respectively, which are given by the series

$$f^{(a)}(z) = \sum_{r=0}^{\infty} a_r^{(a)} T_{2r}(z) \quad -1 \leq z \leq 1 \quad (\text{D-26})$$

and

$$g^{(a)}(z) = \sum_{r=0}^{\infty} b_r^{(a)} T_{2r}(z) \quad -1 \leq z \leq 1 \quad (\text{D-27})$$

where all but a finite number of the $a_r^{(a)}$, $b_r^{(a)}$, $r = 0, 1, 2, \dots$, are zero.

If we differentiate formulae (D-26) and (D-27) with respect to z we get

$$\frac{d}{dz} f^{(a)}(z) = 2z \sum_{r=0}^{\infty} a_r^{(1a)} T_{2r}(z) \quad (\text{D-28})$$

and

$$\frac{d}{dz} g^{(a)}(z) = 2z \sum_{r=0}^{\infty} b_r^{(1a)} T_{2r}(z) \quad (\text{D-29})$$

Because of the properties

$$\left. \begin{aligned} 4zT_{2r}(z) &= \frac{1}{(2r+2)} \frac{d}{dz} T_{2r+2}(z) - \frac{1}{(2r-2)} \frac{d}{dz} T_{2r-2}(z), \quad r > 2, \\ 4zT_2(z) &= \frac{1}{4} \frac{d}{dz} T_4(z) \\ 4zT_0(z) &= \frac{d}{dz} T_2(z) \end{aligned} \right\} (\text{D-30})$$

of Chebyshev polynomials, we find from formulae (D-26) to (D-29) that

$$4ra_r^{(a)} = a_{r-1}^{(1a)} - a_{r+1}^{(1a)}, \quad r > 1 \quad (\text{D-31})$$

and

$$4rb_r^{(a)} = b_{r-1}^{(1a)} - b_{r+1}^{(1a)}, \quad r > 1. \quad (\text{D-32})$$

Because of the property

$$4z^2 T_{2r}(z) = T_{|2r-2|}(z) + 2T_{2r}(z) + T_{2r+2}(z), \quad \text{all integer } r, \quad (\text{D-33})$$

of Chebyshev polynomials, we find from formula (D-28) that

$$z \frac{d}{dz} f^{(a)}(z) = \frac{1}{2} \sum_{r=0}^{\infty} \left(a_{|r-1|}^{(1a)} + 2a_r^{(1a)} + a_{r+1}^{(1a)} \right) T_{2r}(z). \quad (\text{D-34})$$

Then, on using formulae (D-26), (D-27), (D-29) and (D-34) we get

$$\begin{aligned} z \frac{df^{(a)}(z)}{dz} + f^{(a)}(z) - g^{(a)}(z) \\ = \sum_{r=0}^{\infty} \left[\frac{1}{2} \left(a_{|r-1|}^{(1a)} + 2a_r^{(1a)} + a_{r+1}^{(1a)} \right) + a_r^{(a)} - b_r^{(a)} \right] T_{2r}(z) \end{aligned} \quad (\text{D-35})$$

and

$$\frac{dg^{(a)}(z)}{dz} + \pi^2 z f^{(a)}(z) = 2z \sum_{r=0}^{\infty} \left[b_r^{(1a)} + \frac{1}{2} \pi^2 a_r^{(a)} \right] T_{2r}(z), \quad (\text{D-36})$$

the left-hand sides of which are of the same form as the respective left-hand sides of (D-24) and (D-25).

Let us now take

$$a_r^{(1a)} = 0, \quad r \geq M+2, \quad (\text{D-37})$$

$$b_r^{(1a)} = 0, \quad r \geq M+2, \quad (\text{D-38})$$

$$\frac{1}{2} \left(a_{|r-1|}^{(1a)} + 2a_r^{(1a)} + a_{r+1}^{(1a)} \right) + a_r^{(a)} - b_r^{(a)} = 0, \quad 0 \leq r \leq M+1, \quad (\text{D-39})$$

and

$$b_r^{(1a)} + \frac{1}{2}\pi^2 a_r^{(a)} = 0, \quad 0 \leq r \leq M+1, \quad (D-40)$$

where M is a positive integer.

From the imposed values (D-37) and (D-38) and the formulae (D-31) and (D-32) we get

$$a_r^{(a)} = 0, \quad r \geq M+3, \quad (D-41)$$

$$b_r^{(a)} = 0, \quad r \geq M+3. \quad (D-42)$$

The formulae (D-35) and (D-36) then become

$$z \frac{df^{(a)}(z)}{dz} + f^{(a)}(z) - g^{(a)}(z) = \left[\frac{1}{2}a_{M+1}^{(1a)} + a_{M+2}^{(a)} - b_{M+2}^{(a)} \right] T_{2M+4}(z) \quad (D-43)$$

and

$$\frac{dg^{(a)}(z)}{dz} + \pi^2 z f^{(a)}(z) = \pi^2 z a_{M+2}^{(a)} T_{2M+4}(z). \quad (D-44)$$

If we use formula (D-31) to eliminate $a_{|r-1|}^{(1a)}$ from formula (D-39) for $r \geq 1$ we get

$$(2r+1)a_r^{(a)} + a_r^{(1a)} + a_{r+1}^{(1a)} - b_r^{(a)} = 0, \quad 0 \leq r \leq M+1. \quad (D-45)$$

The formula (D-45) is identical with formula (D-39) when $r = 0$ and it is therefore correct when $r = 0$. Formula (D-45) contains one less coefficient than does formula (D-39), and is, on that account, a little more convenient for our purposes. The set of equations (D-31), (D-32), (D-40) and (D-45) is sufficient to enable us to express $a_{M+1}^{(1a)}$, $b_{M+1}^{(1a)}$, $a_{M+1}^{(a)}$, $b_{M+1}^{(a)}$, $a_M^{(1a)}$, $b_M^{(1a)}$, $a_M^{(a)}$, $b_M^{(a)}$, ..., $a_0^{(1a)}$, $b_0^{(1a)}$, $a_0^{(a)}$, $b_0^{(a)}$ as linear combinations of the undetermined coefficients $a_{M+2}^{(a)}$ and $b_{M+2}^{(a)}$. To proceed further and determine the values of the coefficients $a_{M+2}^{(a)}$ and $b_{M+2}^{(a)}$ we impose specific values on $f^{(a)}(0)$ and $g^{(a)}(0)$. Let us put

$$f^{(a)}(0) = f(0) = 1 \quad (D-46)$$

and

$$g^{(a)}(0) = g(0) = 1. \quad (D-47)$$

If we put $z = 0$ in formula (D-43), use the values (D-46) and (D-47), the formula (D-31), and the property

$$T_{2r}(0) = (-1)^r \tag{D-48}$$

of the Chebyshev polynomials, we get the formula

$$(2M + 5)a_{M+2}^{(a)} - b_{M+2}^{(a)} = 0 . \tag{D-49}$$

If we put $z = 0$ in formula (D-26), use the value (D-46) and the property (D-48) of the Chebyshev polynomials we get the formula

$$\sum_{r=0}^{M+2} (-1)^r a_r^{(a)} = 1 . \tag{D-50}$$

We now proceed as follows, with $a_{M+2}^{(a)}$ treated as an undetermined coefficient:

put $a_{M+3}^{(1a)} = 0$

put $a_{M+3}^{(1a)} = 0$

put $a_{M+2}^{(1a)} = 0$

put $b_{M+2}^{(a)} = 0$

from formula (D-49) evaluate $b_{M+2}^{(a)} = (2M + 5)a_{M+2}^{(a)}$

$p = 1(1)M + 2$

from formula (D-31) evaluate $a_{M-p+2}^{(1a)} = 4(M-p+3)a_{M-p+3}^{(a)} + a_{M-p+4}^{(1a)}$

from formula (D-32) evaluate $b_{M-p+2}^{(1a)} = 4(M-p+3)b_{M-p+3}^{(a)} + b_{M-p+4}^{(1a)}$

from formula (D-40) evaluate $a_{M-p+2}^{(a)} = -\frac{2}{\pi} b_{M-p+2}^{(1a)}$

from formula (D-45) evaluate $b_{M-p+2}^{(a)} = (2M - 2p + 5)a_{M-p+2}^{(a)} + a_{M-p+2}^{(1a)} + a_{M-p+3}^{(1a)}$

..... (D-51)

79125

From the procedure (D-51) we get in turn $b_{M+2}^{(a)}$, $a_{M+1}^{(1a)}$, $b_{M+1}^{(1a)}$, $a_{M+1}^{(a)}$, $b_{M+1}^{(a)}$, $a_M^{(1a)}$, $b_M^{(1a)}$, $a_M^{(a)}$, $b_M^{(a)}$, ..., $a_0^{(1a)}$, $b_0^{(1a)}$, $a_0^{(a)}$, $b_0^{(a)}$ as known multiples of the undetermined coefficients $a_{M+2}^{(a)}$. If then we insert the multiples of $a_{M+2}^{(a)}$ for a_r , $r = 0(1)M+1$, into the equation (D-50) we can determine the value of the coefficient $a_{M+2}^{(a)}$ and from this we may then determine the values of the coefficients $a_r^{(a)}$, $r = 0(1)M+1$, and $b_r^{(a)}$, $r = 0(1)M+2$. The approximations (D-26) and (D-27) for $f^{(a)}(z)$ and $g^{(a)}(z)$ are now known and may be written as

$$f^{(a)}(z) = \sum_{r=0}^{M+2} a_r^{(a)} T_{2r}(z) \quad -1 < z < 1, \quad (D-52)$$

and

$$g^{(a)}(z) = \sum_{r=0}^{M+2} b_r^{(a)} T_{2r}(z) \quad -1 < z < 1. \quad (D-53)$$

The approximations $f^{(a)}(z)$ and $g^{(a)}(z)$ of formulae (D-52) and (D-53) are good approximations to $f(z)$ and $g(z)$ only if the coefficients of $T_{2M+4}(z)$ on the right-hand sides of equations (D-43) and (D-44) are very small compared with unity. It is found that these coefficients do become progressively smaller as the value of M is increased and we can take M to be high enough for $f^{(a)}(z)$ and $g^{(a)}(z)$ to be accurate representations of $f(z)$ and $g(z)$ to any given number of decimal digits.

We now take an approximation $k^{(a)}(z)$ to $k(z)$ of formula (D-8) to be given by the formula

$$k^{(a)}(z) = \frac{f^{(a)}(z) - f^{(a)}(1)}{1 - z^2}. \quad (D-54)$$

Even though $f(1)$ is zero, $f^{(a)}(1)$ is not precisely zero and hence it has to be brought into the formula (D-54). The function $k^{(a)}(z)$ defined by formula (D-54) may be written as the series of Chebyshev polynomials

$$k^{(a)}(z) = \sum_{r=0}^{M+1} d_r^{(a)} T_{2r}(z) \quad -1 < z < 1. \quad (D-55)$$

By using the series (D-52) and (D-55) and the property (D-33) of Chebyshev polynomials we get from formula (D-54) the equation

$$\begin{aligned}
 0 &= f^{(a)}(z) - f^{(a)}(1) - (1 - z^2)k^{(a)}(z) \\
 &= \sum_{r=0}^{M+2} a_r^{(a)} T_{2r}(z) - f^{(a)}(1) + \frac{1}{2} \sum_{r=0}^M \left(d_{|r-1|}^{(a)} - 2d_r^{(a)} + d_{r+1}^{(a)} \right) T_{2r}(z) \\
 &\quad + \frac{1}{2} \left(d_M^{(a)} - 2d_{M+1}^{(a)} \right) T_{2M+2}(z) + \frac{1}{2} d_{M+1}^{(a)} T_{2M+4}(z) . \quad (D-56)
 \end{aligned}$$

Equating to zero the coefficients of $T_{2r}(z)$, $r = 0(1)M+2$, in equation (D-56) we get the set of equations

$$\frac{1}{2} a_0^{(a)} - f^{(a)}(1) + \frac{1}{2} \left(d_1^{(a)} - d_0^{(a)} \right) = 0 , \quad (D-57)$$

$$a_r^{(a)} + \frac{1}{2} \left(d_{r-1}^{(a)} - 2d_r^{(a)} + d_{r+1}^{(a)} \right) = 0 , \quad r = 1(1)M, \quad (D-58)$$

$$a_{M+1}^{(a)} + \frac{1}{2} \left(d_M^{(a)} - 2d_{M+1}^{(a)} \right) = 0 , \quad (D-59)$$

$$a_{M+2}^{(a)} + \frac{1}{2} d_{M+1}^{(a)} = 0 . \quad (D-60)$$

By using the property

$$T_{2r}(1) = 1 \quad (D-61)$$

of Chebyshev polynomials and the series (D-52) for $f^{(a)}(z)$ we can write the equation (D-57) in the form

$$\sum_{r=1}^{M+2} a_r^{(a)} - \frac{1}{2} \left(d_1^{(a)} - d_0^{(a)} \right) = 0 . \quad (D-62)$$

This is precisely the equation that we get if we add together all the equations (D-58), the equation (D-59) and the equation (D-60), and it is therefore

redundant. From the set of $M+2$ linear equations (D-58), (D-59) and (D-60) we can determine the $M+2$ coefficients $d_r^{(a)}$, $r = 0(1)M+1$, in terms of the $M+2$ known coefficients $a_r^{(a)}$, $r = 1(1)M+2$. The approximation (D-55) for $k^{(a)}(z)$ is then known. We now take an approximation $\ell^{(a)}(z)$ to $\ell(z)$ of formula (D-21) to be given by the formula

$$\ell^{(a)}(z) = \frac{g^{(a)}(z) + 2k^{(a)}(z) - g^{(a)}(1) - 2k^{(a)}(1)}{1 - z^2} . \quad (D-63)$$

Even though $g(1)$ and $2k(1)$ are zero, $g^{(a)}(1) + 2k^{(a)}(1)$ is not precisely zero and hence it has to be brought into the formula (D-63). The function $\ell^{(a)}(z)$ defined by formula (D-63) may be written as the series of Chebyshev polynomials

$$\ell^{(a)}(z) = \sum_{r=0}^{M+1} \ell_r^{(a)} T_{2r}(z) , \quad -1 \leq z \leq 1. \quad (D-64)$$

By using the series (D-53), (D-55) and (D-64) and the property (D-33) of Chebyshev polynomials we get from formula (D-63)

$$\begin{aligned} 0 &= g^{(a)}(z) + 2k^{(a)}(z) - g^{(a)}(1) - 2k^{(a)}(1) - (1 - z^2)\ell^{(a)}(z) \\ &= \sum_{r=0}^{M+1} \left(b_r^{(a)} + 2d_r^{(a)} \right) T_{2r}(z) + b_{M+2}^{(a)} T_{2M+4}(z) - g^{(a)}(1) - 2k^{(a)}(1) \\ &\quad + \frac{1}{2} \sum_{r=0}^M \left(\ell_{|r-1|}^{(a)} - 2\ell_r^{(a)} + \ell_{r+1}^{(a)} \right) T_{2r}(z) + \frac{1}{2} \left(\ell_M^{(a)} - 2\ell_{M+1}^{(a)} \right) T_{2M+2}(z) \\ &\quad + \frac{1}{2} \ell_{M+1}^{(a)} T_{2M+4}(z) . \end{aligned} \quad (D-65)$$

Equating to zero the coefficients of $T_{2r}(z)$, $r = 0(1)M+2$, in equation (D-65) we get the set of equations

$$\frac{1}{2}b_0^{(a)} + d_0^{(a)} - g^{(a)}(1) - 2k^{(a)}(1) + \frac{1}{2}(\ell_1^{(a)} - \ell_0^{(a)}) = 0, \quad (D-66)$$

$$b_r^{(a)} + 2d_r^{(a)} + \frac{1}{2}(\ell_{r-1}^{(a)} - 2\ell_r^{(a)} + \ell_{r+1}^{(a)}) = 0, \quad r = 1(1)M, \quad (D-67)$$

$$b_{M+1}^{(a)} + 2d_{M+1}^{(a)} + \frac{1}{2}(\ell_M^{(a)} - 2\ell_{M+1}^{(a)}) = 0, \quad (D-68)$$

$$b_{M+2}^{(a)} + \frac{1}{2}\ell_{M+1}^{(a)} = 0. \quad (D-69)$$

By using the property (D-61) of the Chebyshev polynomials and the series (D-53) and (D-55) for $g^{(a)}(z)$ and $k^{(a)}(z)$ respectively we can write the equation (D-66) in the form

$$\sum_{r=1}^{M+2} b_r^{(a)} + 2 \sum_{r=1}^{M+1} d_r^{(a)} - \frac{1}{2}(\ell_1^{(a)} - \ell_0^{(a)}) = 0. \quad (D-70)$$

This is precisely the equation that we get if we add together all the equations (D-67), the equation (D-68) and the equation (D-69), and it is therefore redundant. From the set of $M+2$ linear equations (D-67), (D-68) and (D-69) we can determine the $M+2$ coefficients $\ell_r^{(a)}$, $r = 0(1)M+1$, in terms of the known coefficients $b_r^{(a)}$, $r = 1(1)M+2$ and $d_r^{(a)}$, $r = 1(1)M+1$. The approximation (D-64) for $\ell^{(a)}(z)$ is then known.

We now seek an approximation $h^{(a)}(z)$ to $h(z)$ of formula (D-23) as the series of Chebyshev polynomials

$$h^{(a)}(z) = \sum_{r=0}^{\infty} c_r^{(a)} T_{2r}(z) \quad -1 \leq z \leq 1 \quad (D-71)$$

where all but a finite number of the $c_r^{(a)}$ are zero. By using the series (D-55) and (D-71) and the property

$$T_{2r}(z)T_{2s}(z) = \frac{1}{2}\{T_{|2r-2s|}(z) + T_{2r+2s}(z)\} \quad (D-72)$$

of Chebyshev polynomials we get the formula

$$\begin{aligned}
 k^{(a)}(z)h^{(a)}(z) &= \sum_{r=0}^{M+1} d_r^{(a)} T_{2r}(z) \sum_{s=0}^{\infty} c_s^{(a)} T_{2s}(z) \\
 &= \frac{1}{2} \sum_{r=0}^{M+1} \sum_{s=0}^{\infty} d_r^{(a)} c_s^{(a)} \{ T_{|2r-2s|}(z) + T_{2r+2s}(z) \} \\
 &= \frac{1}{2} \sum_{p=0}^{\infty} T_{2p}(z) \left\{ \sum_{q=0}^p (d_{p-q}^{(a)} + d_{p+q}^{(a)}) c_q^{(a)} + \sum_{q=p+1}^{\infty} (d_{q-p}^{(a)} + d_{q+p}^{(a)}) c_q^{(a)} \right\} \\
 &\dots\dots (D-73)
 \end{aligned}$$

in which we have taken

$$d_r^{(a)} = 0, \quad r \geq M+2. \quad (D-74)$$

Hence

$$\begin{aligned}
 k^{(a)}(z)h^{(a)}(z) - \ell^{(a)}(z) &= \frac{1}{2} \sum_{p=0}^{\infty} T_{2p}(z) \left\{ \sum_{q=0}^p (d_{p-q}^{(a)} + d_{p+q}^{(a)}) c_q^{(a)} + \sum_{q=p+1}^{\infty} (d_{q-p}^{(a)} + d_{q+p}^{(a)}) c_q^{(a)} \right\} \\
 &\quad - \sum_{p=0}^{M+1} \ell_p^{(a)} T_{2p}(z). \quad (D-75)
 \end{aligned}$$

We choose the coefficients $c_r^{(a)}$ such that

$$\frac{1}{2} d_0^{(a)} c_0^{(a)} + \frac{1}{2} \sum_{q=1}^{M+1} d_q^{(a)} c_q^{(a)} = \frac{1}{2} \ell_0^{(a)}, \quad (D-76)$$

$$\frac{1}{2} \sum_{q=0}^p (d_{p-q}^{(a)} + d_{p+q}^{(a)}) c_q^{(a)} + \frac{1}{2} \sum_{q=p+1}^{M+1} (d_{q-p}^{(a)} + d_{q+p}^{(a)}) c_q^{(a)} = \ell_p^{(a)}, \quad (D-77)$$

$$p = 1(1)M$$

$$\frac{1}{2} \sum_{q=0}^{M+1} \left(d_{p-q}^{(a)} + d_{p+q}^{(a)} \right) c_q^{(a)} = \ell_{M+1}^{(a)}, \quad (D-78)$$

$$c_q^{(a)} = 0, \quad q \geq M+2. \quad (D-79)$$

The equations (D-76) to (D-78) are a set of $M+2$ linear simultaneous equations from which the $M+2$ coefficients $c_r^{(a)}$, $r=0(1)M+1$, may be determined in terms of the known coefficients $\ell_r^{(a)}$, $r=0(1)M+1$, and $d_r^{(a)}$, $r=0(1)M+1$. The coefficients in equations (D-76) to (D-78) are a symmetric set.

When the coefficients $c_r^{(a)}$, $r=0(1)M+1$, have been determined the approximation (D-71) for $h^{(a)}(z)$ is known and may be written as

$$h^{(a)}(z) = \sum_{r=0}^{M+1} c_r^{(a)} T_{2r}(z) \quad -1 \leq z \leq 1. \quad (D-80)$$

By using the equations (D-76) to (D-78) in formula (D-75) we get the formula

$$k^{(a)}(z)h^{(a)}(z) - \ell^{(a)}(z) = \frac{1}{2} \sum_{p=M+2}^{2M+2} T_{2p}(z) \sum_{q=p-M-1}^{M+1} d_{p-q}^{(a)} c_q^{(a)}. \quad (D-81)$$

Therefore the function $h^{(a)}(z)$ given by formula (D-80) is a good approximation to the function $h(z)$ of formula (D-23) if all the coefficients

$$\frac{1}{2} \sum_{q=p-M-1}^{M+1} d_{p-q}^{(a)} c_q^{(a)}, \quad p = M+2(1)2M+2,$$

appearing on the right-hand side of formula (D-81) are very small compared with unity. It is found that these coefficients do become progressively smaller as the value of M is increased.

We now take an approximation $H^{(a)}(z)$ to $H(z)$ of formula (D-15) to be given by the formula

$$H^{(a)}(z) = \frac{1}{z} \int_0^z h^{(a)}(z_0) dz_0 . \quad (D-82)$$

The function $H^{(a)}(z)$ defined by formula (D-82) may be written as the series of Chebyshev polynomials

$$H^{(a)}(z) = \sum_{r=0}^{M+1} e_r^{(a)} T_{2r}(z) . \quad (D-83)$$

By using the property

$$zT_{2r}(z) = \frac{1}{2} \{ T_{|2r-1|}(z) + T_{2r+1}(z) \} \quad (D-84)$$

of Chebyshev polynomials, we find from formula (D-83) that

$$zH^{(a)}(z) = \frac{1}{2} \sum_{r=0}^M (e_r^{(a)} + e_{r+1}^{(a)}) T_{2r+1}(z) + \frac{1}{2} e_{M+1}^{(a)} T_{2M+3}(z) . \quad (D-85)$$

By using the properties

$$2T_{2r}(z) = \frac{1}{(2r+1)} \frac{d}{dz} T_{2r+1}(z) - \frac{1}{(2r-1)} \frac{d}{dz} T_{2r-1}(z) , \quad r \geq 1,$$

$$2T_0(z) = 2 \frac{d}{dz} T_1(z) \quad (D-86)$$

of Chebyshev polynomials, we find from formula (D-80) that

$$\int_0^z h^{(a)}(z_0) dz_0 = \frac{1}{2} \sum_{r=0}^M (c_r^{(a)} - c_{r+1}^{(a)}) \frac{T_{2r+1}(z)}{(2r+1)} + c_{M+1}^{(a)} \frac{T_{2M+3}(z)}{2(2M+3)} . \quad (D-87)$$

Hence, from formula (D-82) on using formulae (D-85) and (D-87) we get

$$\begin{aligned} & \frac{1}{2} \sum_{r=0}^M (e_r^{(a)} + e_{r+1}^{(a)}) T_{2r+1}(z) + \frac{1}{2} e_{M+1}^{(a)} T_{2M+3}(z) \\ &= \frac{1}{2} \sum_{r=0}^M (c_r^{(a)} - c_{r+1}^{(a)}) \frac{T_{2r+1}(z)}{(2r+1)} + \frac{1}{2} c_{M+1}^{(a)} \frac{T_{2M+3}(z)}{(2M+3)}. \end{aligned} \quad (D-88)$$

Equating the coefficients of $T_{2r+1}(z)$, $r=0(1)M+1$, on both sides of equation (D-88) we get the set of equations

$$e_r^{(a)} + e_{r+1}^{(a)} = \frac{1}{(2r+1)} (c_r^{(a)} - c_{r+1}^{(a)}), \quad r=0(1)M, \quad (D-89)$$

$$e_{M+1}^{(a)} = \frac{1}{(2M+3)} c_{M+1}^{(a)}. \quad (D-90)$$

From the set of $M+2$ linear equations (D-89) and (D-90) we can determine the $M+2$ coefficients $e_r^{(a)}$, $r=0(1)M+1$, in terms of the $M+2$ known coefficients $c_r^{(a)}$, $r=0(1)M+1$. The approximation (D-83) for $H^{(a)}(z)$ is then known and the approximation for $I(\theta)$ is obtained from formula (D-14) on replacing $H(z)$ by $H^{(a)}(z)$.

We now collect together results and give numerical values that have been obtained for the coefficients using the processes described. We take M large enough for the values obtained as approximations to be indistinguishable from the exact values to the number of decimal places quoted.

From formulae (D-5) to (D-7), (D-17) and (D-18) we have

$$\frac{\sin \theta}{\theta} = \sum_{r=0}^{\infty} a_r T_{2r}\left(\frac{\theta}{\pi}\right), \quad -\pi \leq \theta \leq \pi, \quad (D-91)$$

$$\cos \theta = \sum_{r=0}^{\infty} b_r T_{2r}\left(\frac{\theta}{\pi}\right), \quad -\pi \leq \theta \leq \pi, \quad (D-92)$$

| | | | |
|-------|---|--|---|
| where | $a_0 = 0.85786189571$ $a_1 = -0.49547838573$ $a_2 = 0.07090604556$ $a_3 = -0.00451782771$ $a_4 = 0.00016294515$ $a_5 = -0.00000378582$ $a_6 = 0.00000006144$ $a_7 = -0.00000000074$ $a_8 = 0.00000000001$ $a_9 = -0.00000000000$ | $b_0 = -0.60848435529$ $b_1 = -0.97086786526$ $b_2 = 0.30284915526$ $b_3 = -0.02909193397$ $b_4 = 0.00139224399$ $b_5 = -0.00004018994$ $b_6 = 0.00000077828$ $b_7 = -0.00000001083$ $b_8 = 0.00000000011$ $b_9 = -0.00000000000$ | $\left. \vphantom{\begin{matrix} a_0 \\ a_1 \\ a_2 \\ a_3 \\ a_4 \\ a_5 \\ a_6 \\ a_7 \\ a_8 \\ a_9 \end{matrix}} \right\} \text{(D-93)}$ |
|-------|---|--|---|

From formulae (D-5), (D-11) and (D-19) we have

$$\frac{\theta \cos \theta}{\sin \theta} = -\frac{2\pi^2}{(\pi^2 - \theta^2)} + \sum_{r=0}^{\infty} c_r T_{2r}\left(\frac{\theta}{\pi}\right), \quad -\pi \leq \theta \leq \pi, \quad (\text{D-94})$$

| | | |
|-------|---|---|
| where | $c_0 = 4.55924045122$ $c_1 = -0.74814923172$ $c_2 = -0.02949333285$ $c_3 = -0.00184181211$ $c_4 = -0.00012625400$ $c_5 = -0.00000891042$ $c_6 = -0.00000063548$ $c_7 = -0.00000004550$ $c_8 = -0.00000000326$ $c_9 = -0.00000000023$ $c_{10} = -0.00000000002$ $c_{11} = -0.00000000000$ | $\left. \vphantom{\begin{matrix} c_0 \\ c_1 \\ c_2 \\ c_3 \\ c_4 \\ c_5 \\ c_6 \\ c_7 \\ c_8 \\ c_9 \\ c_{10} \\ c_{11} \end{matrix}} \right\} \text{(D-95)}$ |
|-------|---|---|

From formula (D-5), (D-14) and (D-16) we have

$$I(\theta) = 2\pi \log\left(\frac{\pi + \theta}{\pi - \theta}\right) - 2\theta \sum_{r=0}^{\infty} e_r T_{2r}\left(\frac{\theta}{\pi}\right), \quad -\pi \leq \theta \leq \pi, \quad (\text{D-96})$$

where

$$\begin{aligned} e_0 &= 5.54164409617 \\ e_1 &= -0.23425441323 \\ e_2 &= -0.00529755301 \\ e_3 &= -0.00023275109 \\ e_4 &= -0.00001232864 \\ e_5 &= -0.00000070953 \\ e_6 &= -0.00000004273 \\ e_7 &= -0.00000000265 \\ e_8 &= -0.00000000017 \\ e_9 &= -0.00000000001 \\ e_{10} &= -0000000000000 \end{aligned}$$

(D-97)

Appendix E

ANALYTICAL EVALUATION OF SPANWISE INTEGRALS

In this Appendix we derive the tractable expressions for the spanwise integrals

$$\int_0^1 \log|n - n_0| \sqrt{1 - n_0} \, dn_0 = \frac{2}{3} \log|n| + \frac{2}{3} (1 - n)^{\frac{3}{2}} \log\left(\frac{1 + \sqrt{1 - n}}{1 - \sqrt{1 - n}}\right) - \frac{4}{3} (1 - n) - \frac{4}{9} \quad (E-1)$$

$$\int_0^1 \frac{\sqrt{1 - n_0}}{(n - n_0)} \, dn_0 = 2 - \sqrt{1 - n} \log\left(\frac{1 + \sqrt{1 - n}}{1 - \sqrt{1 - n}}\right) \quad (E-2)$$

and

$$\int_0^1 \frac{\sqrt{1 - n_0}}{(n - n_0)^2} \, dn_0 = -\frac{1}{2\sqrt{1 - n}} \log\left(\frac{1 + \sqrt{1 - n}}{1 - \sqrt{1 - n}}\right) - \frac{1}{n} \quad (E-3)$$

Let us write

$$L(n) = \int_0^1 \log|n - n_0| \sqrt{1 - n_0} \, dn_0 \quad (E-4)$$

We have then

$$\begin{aligned} L(n) &= -\frac{2}{3} \int_0^1 \log|n - n_0| \frac{d}{dn_0} \left\{ (1 - n_0)^{\frac{3}{2}} \right\} dn_0 \\ &= -\frac{2}{3} \left[\log|n - n_0| (1 - n_0)^{\frac{3}{2}} \right]_0^1 - \frac{2}{3} \int_0^1 \frac{(1 - n_0)^{\frac{3}{2}}}{(n - n_0)} \, dn_0 \\ &= \frac{2}{3} \log|n| - \frac{2}{3} \int_0^1 (2 - n - n_0) \frac{dn_0}{\sqrt{1 - n_0}} - \frac{2}{3} (1 - n)^2 \int_0^1 \frac{1}{(n - n_0)} \frac{dn_0}{\sqrt{1 - n_0}} \\ &= \frac{2}{3} \log|n| - \frac{4}{3} (1 - n) - \frac{4}{9} - \frac{2}{3} (1 - n)^2 \int_0^1 \frac{1}{(n - n_0)} \frac{dn_0}{\sqrt{1 - n_0}} \quad (E-5) \end{aligned}$$

Now

$$\begin{aligned}
\int_0^1 \frac{1}{(n-\eta_0)} \frac{d\eta_0}{\sqrt{1-\eta_0}} &= \frac{1}{2\sqrt{1-\eta}} \int_0^1 \left\{ \frac{1}{(\sqrt{1-\eta_0} - \sqrt{1-\eta})} - \frac{1}{(\sqrt{1-\eta_0} + \sqrt{1-\eta})} \right\} \frac{d\eta_0}{\sqrt{1-\eta_0}} \\
&= \frac{1}{\sqrt{1-\eta}} \left[\log \left| \frac{\sqrt{1-\eta_0} + \sqrt{1-\eta}}{\sqrt{1-\eta_0} - \sqrt{1-\eta}} \right| \right]_{\eta_0=0}^1 \\
&= -\frac{1}{\sqrt{1-\eta}} \log \left(\frac{1 + \sqrt{1-\eta}}{1 - \sqrt{1-\eta}} \right) . \tag{E-6}
\end{aligned}$$

Hence from formulae (E-5) and (E-6) we get

$$L(\eta) = \frac{2}{3} \log|\eta| + \frac{2}{3} (1-\eta)^{\frac{3}{2}} \log \left(\frac{1 + \sqrt{1-\eta}}{1 - \sqrt{1-\eta}} \right) - \frac{4}{3} (1-\eta) - \frac{4}{9} . \tag{E-7}$$

By straightforward differentiation of formula (E-7) once and twice with respect to η we get

$$\int_0^1 \frac{\sqrt{1-\eta_0}}{(n-\eta_0)} d\eta_0 = \frac{d}{d\eta} L(\eta) = 2 - \sqrt{1-\eta} \log \left(\frac{1 + \sqrt{1-\eta}}{1 - \sqrt{1-\eta}} \right) , \tag{E-8}$$

and

$$\int_0^1 \frac{\sqrt{1-\eta_0}}{(n-\eta_0)^2} d\eta_0 = -\frac{d^2}{d\eta^2} L(\eta) = -\frac{1}{2\sqrt{1-\eta}} \log \left(\frac{1 + \sqrt{1-\eta}}{1 - \sqrt{1-\eta}} \right) - \frac{1}{\eta} . \tag{E-9}$$

The expressions (E-1) to (E-3) have therefore been obtained. The expression (E-2) could, alternatively be obtained directly by using the result (E-6)

Appendix F

NUMERICAL EVALUATION OF $y^4 F(x,y;\nu,M)$

The function $F(x,y;\nu,M)$ is defined in formula (2-22) of the main text. We shall write

$$y^4 F(x,y;\nu,M) = 3Q(x,y;\nu,M) + y^4 \exp(-i\nu X) \left\{ \frac{M(Mx+R)^3}{R(x^2+y^2)^3} + \frac{M^2 \beta^2 x}{R^3(x^2+y^2)} + \frac{2M(Mx+R)}{R(x^2+y^2)^2} + i\nu \frac{M^2(Mx+R)}{R^2(x^2+y^2)} \right\} \quad (F-1)$$

where

$$Q(x,y;\nu,M) = y^4 \int_X^\infty \exp(-i\nu\lambda) \frac{d\lambda}{(\lambda^2+y^2)^{\frac{3}{2}}} = \int_{X/|y|}^\infty \exp(-i\nu|y|\lambda) \frac{d\lambda}{(\lambda^2+1)^{\frac{3}{2}}} \quad (F-2)$$

and

$$X = \frac{-x + MR}{\beta^2} \quad (F-3)$$

The only part of the right-hand side of formula (F-1) that is at all complicated to evaluate is $Q(x,y;\nu,M)$. The methods of evaluation are different for $|X|/|y|$ large and for $|X|/|y|$ not large. We shall first consider the case when $|X|/|y|$ is not large.

We write formula (F-2) in the form

$$Q(x,y;\nu,M) = \int_0^\infty \exp(-i\nu|y|\lambda) \frac{d\lambda}{(\lambda^2+1)^{\frac{3}{2}}} - \int_0^{X/|y|} \exp(-i\nu|y|\lambda) \frac{d\lambda}{(\lambda^2+1)^{\frac{3}{2}}} \quad \dots\dots (F-4)$$

The integral over the finite interval $(0, X/|y|)$ of λ on the right-hand side of formula (F-4) can be evaluated numerically in a straightforward manner. The procedure adopted is to divide the interval $(0, X/|y|)$ into a number of sub-intervals, the length of any subinterval not being greater than 1 or $\pi/\nu|y|$. A Gaussian numerical integration with weight function 1 is then carried out over each subinterval using a small number of integration points. This procedure is satisfactory, except when the number of subintervals becomes very large, as happens if either $|X|/|y|$ or $\nu|X|/\pi$ is very large. We do not anticipate dealing with such a large ν that $\nu|X|/\pi$ is so large that the above procedure is unacceptable, but $|X|/|y|$ could be large enough to make the above procedure unacceptably lengthy. We shall later choose a demarcation value of $|X|/|y|$ and when $|X|/|y|$ is greater than this value use a different procedure for obtaining $Q(x,y;\nu,M)$ from formula (F-2).

We write the integral over the infinite interval $(0,\infty)$ of λ on the right-hand side of formula (F-4) in the form

$$\int_0^{\infty} \exp(-i\nu|y|\lambda) \frac{d\lambda}{(\lambda^2 + 1)^{\frac{1}{2}}} = F(\nu|y|) + iG(\nu|y|) \quad (\text{F-5})$$

where the functions $F(\alpha)$ and $G(\alpha)$ are real functions of α for real α . These functions may be expressed in terms of modified Bessel and Struve functions but are better expressed in terms of expansions in series of Chebyshev polynomials as far as their numerical evaluation is concerned.

As in Ref 11 we may write for $A \leq \alpha < \infty$,

$$F(\alpha) = \alpha\sqrt{\alpha} e^{-\alpha} \sum_{r=0}^{\infty} A_r(A) T_r\left(\frac{2A}{\alpha} - 1\right), \quad (\text{F-6})$$

$$G(\alpha) = -\frac{1}{\alpha} \sum_{r=0}^{\infty} B_r(A) T_{2r}\left(\frac{A}{\alpha}\right), \quad (\text{F-7})$$

and for $0 \leq \alpha < A$,

$$F(\alpha) = \sum_{r=0}^{\infty}{}' D_r(A) T_{2r}\left(\frac{\alpha}{A}\right) - \frac{\alpha^4}{24} \sum_{r=0}^{\infty}{}' C_r(A) T_{2r}\left(\frac{\alpha}{A}\right) \log\left(\frac{\alpha}{A}\right), \quad (\text{F-8})$$

$$G(\alpha) = \alpha \sum_{r=0}^{\infty}{}' R_r(A) T_{2r}\left(\frac{\alpha}{A}\right) - \frac{\pi\alpha^4}{48} \sum_{r=0}^{\infty}{}' C_r(A) T_{2r}\left(\frac{\alpha}{A}\right), \quad (\text{F-9})$$

where A is any positive quantity which we call the demarcation value of α , and the dash ' on the summation sign \sum is used to indicate that the $r = 0$ term must be multiplied by $\frac{1}{2}$ before being summed. The Chebyshev polynomial $T_r(x)$ is a polynomial of degree r in x which is given by formula (C-55) of Appendix C.

The coefficients $A_r(A)$, $B_r(A)$, $C_r(A)$, $D_r(A)$ and $R_r(A)$ for $r = 0, 1, 2, \dots$, for a given value of A may be determined numerically by applying the method of Clenshaw¹⁵ as is done in Ref 11. If we take $A = 6$ we get the following values of these coefficients.

| | | | |
|------------------------|---------------------------|---|--------|
| $A_0(6) = 0.97290965$ | $B_0(6) = 2.18559166$ | } | (F-10) |
| $A_1(6) = 0.06979380$ | $B_1(6) = 0.09347555$ | | |
| $A_2(6) = 0.00109596$ | $B_2(6) = -0.00455837$ | | |
| $A_3(6) = -0.00001391$ | $B_3(6) = -0.00497478$ | | |
| $A_4(6) = 0.00000046$ | $B_4(6) = 0.00083423$ | | |
| $A_5(6) = -0.00000002$ | $B_5(6) = 0.00033774$ | | |
| | $B_6(6) = -0.00022727$ | | |
| | $B_7(6) = 0.00004726$ | | |
| | $B_8(6) = 0.00001560$ | | |
| | $B_9(6) = -0.00001833$ | | |
| | $B_{10}(6) = 0.00000845$ | | |
| | $B_{11}(6) = -0.00000167$ | | |
| | $B_{12}(6) = -0.00000083$ | | |
| | $B_{13}(6) = 0.00000108$ | | |
| | $B_{14}(6) = -0.00000066$ | | |
| | $B_{15}(6) = 0.00000026$ | | |
| | $B_{16}(6) = -0.00000003$ | | |
| | $B_{17}(6) = -0.00000005$ | | |
| | $B_{18}(6) = 0.00000006$ | | |

$$\left. \begin{aligned} B_{19}(6) &= -0.00000004 \\ B_{20}(6) &= 0.00000002 \\ B_{21}(6) &= -0.00000001 \end{aligned} \right\}$$

$$\left. \begin{array}{lll} C_0(6) = 9.3272289335 & D_0(6) = -21.1445074586 & R_0(6) = 89.6519446660 \\ C_1(6) = 4.5653364673 & D_1(6) = -8.2323109678 & R_1(6) = 67.1285359307 \\ C_2(6) = 1.0237269949 & D_2(6) = 8.6396331451 & R_2(6) = 27.5576475013 \\ C_3(6) = 0.1325631694 & D_3(6) = 7.5551643451 & R_3(6) = 6.4272223460 \\ C_4(6) = 0.0111952468 & D_4(6) = 2.2416456662 & R_4(6) = 0.9205238336 \\ C_5(6) = 0.0006654445 & D_5(6) = 0.3516684303 & R_5(6) = 0.0872610556 \\ C_6(6) = 0.0000293443 & D_6(6) = 0.0343487266 & R_6(6) = 0.0058179902 \\ C_7(6) = 0.0000009979 & D_7(6) = 0.0022925634 & R_7(6) = 0.0002861205 \\ C_8(6) = 0.0000000270 & D_8(6) = 0.000112114 & R_8(6) = 0.0000107737 \\ C_9(6) = 0.0000000006 & D_9(6) = 0.0000040983 & R_9(6) = 00000003200 \\ & D_{10}(6) = 0.0000001186 & R_{10}(6) = 0.0000000077 \\ & D_{11}(6) = 0.0000000028 & R_{11}(6) = 0.0000000002 \end{array} \right\}$$

..... (F-11)

If we now use the values of the coefficients $A_r(6)$, $B_r(6)$, $C_r(6)$, $D_r(6)$ and $R_r(6)$ from lists (F-10) and (F-11) in formulae (F-6) to (F-9), and neglect the remaining higher order coefficients, we can evaluate $F(\alpha)$ and $G(\alpha)$ for any given value of α . By doing this for all the integers α from 0 to 25, using 11 significant figures in the arithmetic, we find the values $F(\alpha)$ and $G(\alpha)$ of Table F1.

The function values tabulated in Table F1 should all be correct to seven decimal places. To achieve this accuracy the coefficients $A_r(6)$ and $B_r(6)$ need to be given only to seven decimal places because of the respective multipliers $\alpha\sqrt{\alpha} e^{-\alpha}$ and $1/\alpha$ in formulae (F-6) and (F-7). The coefficients $C_r(6)$, $D_r(6)$ and $R_r(6)$ need to be given to more than seven decimal places so as to guard against truncation errors.

Table F1

| α | F(α) | G(α) |
|----------|---------------|---------------|
| 0 | 0.6666667 | 0.0000000 |
| 1 | 0.5416130 | -0.2699953 |
| 2 | 0.3383463 | -0.3614598 |
| 3 | 0.1845314 | -0.3446732 |
| 4 | 0.0928076 | -0.2926542 |
| 5 | 0.0442412 | -0.2396526 |
| 6 | 0.0203036 | -0.1962890 |
| 7 | 0.0090578 | -0.1634097 |
| 8 | 0.0039533 | -0.1389717 |
| 9 | 0.0016956 | -0.1206699 |
| 10 | 0.0007170 | -0.1066765 |
| 11 | 0.0002996 | -0.0957016 |
| 12 | 0.0001240 | -0.0868746 |
| 13 | 0.0000509 | -0.0796128 |
| 14 | 0.0000207 | -0.0735224 |
| 15 | 0.0000084 | -0.0683317 |
| 16 | 0.0000034 | -0.0638482 |
| 17 | 0.0000013 | -0.0599322 |
| 18 | 0.0000005 | -0.0564793 |
| 19 | 0.0000002 | -0.0534101 |
| 20 | 0.0000001 | -0.0506626 |
| 21 | 0.0000000 | -0.0481880 |
| 22 | 0.0000000 | -0.0459468 |
| 23 | 0.0000000 | -0.0439072 |
| 24 | 0.0000000 | -0.0420428 |
| 25 | 0.0000000 | -0.0403316 |

Procedures when $|X|/|y|$ is large

To evaluate $Q(x,y;v,M)$ when $X/|y|$ is large and positive we replace $1/(\lambda^2 + 1)^{\frac{1}{2}}$ in the integrand on the right-hand side of (F-2) by its expansion as a power series in $1/\lambda$ and integrate term by term to get

$$Q(x,y;v,M) = \sum_{r=0}^{\infty} (-1)^r \frac{(2r+3)!}{3!2^{2r}r!(r+1)!} \left(\frac{|y|}{X}\right)^{2r+4} E_{2r+5}(vX) \quad (F-12)$$

where
$$E_r(x) = \alpha^{r-1} \int_{\alpha}^{\infty} e^{-iv} \frac{dv}{v^r}, \quad r = 5, 7, 9, \dots \quad (F-13)$$

The expansion on the right-hand side of formula (F-15) is convergent for $X/|y| > 1$ and, the larger $X/|y|$ is, the faster does the expansion (F-15)

converge, i.e. the fewer terms in a finite truncation of it are necessary to get $Q(x,y;\nu,M)$ to a given accuracy. We arbitrarily choose to use the expansion on the right-hand side of formula (F-15) for obtaining $Q(x,y;\nu,M)$ when $x/|y| \geq 2$.

To evaluate the function $E_{2r+5}(\alpha)$ we first use the recurrence relationships

$$E_{2p+5}(\alpha) = \left[\frac{1}{(2p+4)} - \frac{i\alpha}{(2p+4)(2p+3)} \right] e^{-i\alpha} - \frac{\alpha^2}{(2p+4)(2p+3)} E_{2p+3}(\alpha),$$

p = 1, 2, ..., r, (F-14)

to express $E_{2r+5}(\alpha)$ in terms of $E_5(\alpha)$.

We may express $E_5(\alpha)$ in terms of expansions in series of Chebyshev polynomials as follows. For $A < \alpha < \infty$,

$$E_5(\alpha) = \frac{e^{-i\alpha}}{\alpha^2} \sum_{r=0}^{\infty} F_r(A) T_{2r}\left(\frac{A}{\alpha}\right) + \frac{ie^{-i\alpha}}{\alpha} \sum_{r=0}^{\infty} G_r(A) T_{2r}\left(\frac{A}{\alpha}\right), \quad (F-15)$$

and for $0 \leq \alpha \leq A$

$$E_5(\alpha) = \sum_{r=0}^{\infty} M_r(A) T_{2r}\left(\frac{\alpha}{A}\right) - i\alpha \sum_{r=0}^{\infty} N_r(A) T_{2r}\left(\frac{\alpha}{A}\right) - \frac{\alpha^4}{24} \left[\log\left(\frac{\alpha}{A}\right) + i \frac{\pi}{2} \right], \quad (F-16)$$

where A is any positive quantity and the dash ' on the summation sign \sum is used to indicate that the $r = 0$ term must be multiplied by $\frac{1}{2}$ before being summed.

The coefficients $F_r(A)$, $G_r(A)$, $M_r(A)$ and $N_r(A)$ for $r = 0, 1, 2, \dots$, for a given value of A may be determined numerically by applying the method of Clenshaw¹⁵. If we take $A = 7$ we get the following values of these coefficients.

| | | |
|---------------------------|---------------------------|----------|
| $F_0(7) = 7.65464134$ | $G_0(7) = -1.62909283$ | } (F-17) |
| $F_1(7) = -0.96462278$ | $G_1(7) = 0.15793332$ | |
| $F_2(7) = 0.16324156$ | $G_2(7) = -0.02233109$ | |
| $F_3(7) = -0.03370690$ | $G_3(7) = 0.00403132$ | |
| $F_4(7) = 0.00804303$ | $G_4(7) = -0.00086486$ | |
| $F_5(7) = -0.00214405$ | $G_5(7) = 0.00021119$ | |
| $F_6(7) = 0.00062424$ | $G_6(7) = -0.00005708$ | |
| $F_7(7) = -0.00019538$ | $G_7(7) = 0.00001675$ | |
| $F_8(7) = 0.00006497$ | $G_8(7) = -0.00000526$ | |
| $F_9(7) = -0.00002276$ | $G_9(7) = 0.00000175$ | |
| $F_{10}(7) = 0.00000834$ | $G_{10}(7) = -0.00000061$ | |
| $F_{11}(7) = -0.00000318$ | $G_{11}(7) = 0.00000022$ | |
| $F_{12}(7) = 0.00000125$ | $G_{12}(7) = -0.00000009$ | |
| $F_{13}(7) = -0.00000051$ | $G_{13}(7) = 0.00000003$ | |
| $F_{14}(7) = 0.00000021$ | $G_{14}(7) = -0.00000001$ | |
| $F_{15}(7) = -0.00000009$ | $G_{15}(7) = 0.00000001$ | |
| $F_{16}(7) = 0.00000004$ | | |
| $F_{17}(7) = -0.00000002$ | | |
| $F_{18}(7) = 0.00000001$ | | |

| | | |
|-----------------------------|-----------------------------|----------|
| $M_0(7) = -8.1968704256$ | $N_0(7) = -18.97729492493$ | } (F-18) |
| $M_1(7) = -1.2957315228$ | $N_1(7) = -11.49601388513$ | |
| $M_2(7) = 4.3296154754$ | $N_2(7) = -1.54991532641$ | |
| $M_3(7) = 1.1511218834$ | $N_3(7) = 0.11181784175$ | |
| $M_4(7) = -0.1139924574$ | $N_4(7) = -0.01128845453$ | |
| $M_5(7) = 0.0109250052$ | $N_5(7) = 0.00094668728$ | |
| $M_6(7) = -0.0008225064$ | $N_6(7) = -0.00006153704$ | |
| $M_7(7) = 0.0000476892$ | $N_7(7) = 0.00000311325$ | |
| $M_8(7) = -0.0000021631$ | $N_8(7) = -0.00000012490$ | |
| $M_9(7) = 0.0000000784$ | $N_9(7) = 0.00000000405$ | |
| $M_{10}(7) = -0.0000000023$ | $N_{10}(7) = -0.0000000011$ | |

If we now use the values of the coefficients $F_r(7)$, $G_r(7)$, $M_r(7)$ and $N_r(7)$ from lists (F-17) and (F-18) in formulae (F-15) and (F-16), and neglect the remaining higher order coefficients, we can evaluate $E_5(\alpha)$ for any given value of α . By doing this for all the integers α from 0 to 25, using 11 significant figures in the arithmetic, we find the values $E_5(\alpha)$ of Table F2, which should all be correct to seven decimal places.

Table F2

| α | Re $E_5(\alpha)$ | Im $E_5(\alpha)$ |
|----------|------------------|------------------|
| 0 | 0.2500000 | 0.0000000 |
| 1 | 0.0634432 | -0.2238488 |
| 2 | -0.1651166 | -0.1220548 |
| 3 | -0.1565215 | 0.0891612 |
| 4 | 0.0102838 | 0.1585032 |
| 5 | 0.1292800 | 0.0567047 |
| 6 | 0.0998466 | -0.0776958 |
| 7 | -0.0172737 | -0.1129685 |
| 8 | -0.0970204 | -0.0374071 |
| 9 | -0.0743392 | 0.0595212 |
| 10 | 0.0123485 | 0.0868580 |
| 11 | 0.0749055 | 0.0314710 |
| 12 | 0.0610885 | -0.0445369 |
| 13 | -0.0058908 | -0.0703972 |
| 14 | -0.0592043 | -0.0297628 |
| 15 | -0.0530658 | 0.0327766 |
| 16 | -0.0000229 | 0.0588926 |
| 17 | 0.0473720 | 0.0294235 |
| 18 | 0.0474840 | -0.0234137 |
| 19 | 0.0050336 | -0.0501302 |
| 20 | -0.0379780 | -0.0294366 |
| 21 | -0.0431167 | 0.0157951 |
| 22 | -0.0091639 | 0.0429975 |
| 23 | 0.0302142 | 0.0294084 |
| 24 | 0.0393758 | -0.0094831 |
| 25 | 0.0125094 | 0.0369004 |

We may now evaluate $Q(x,y;\nu,M)$ from the infinite series (F-12) when $x/|y| \geq 2$ if we use the relations (F-14) to express the $E_{2r+5}(\nu X)$ in terms of $E_5(\nu X)$ and then evaluate $E_5(\nu X)$ from either the formula (F-15) or the formula (F-16) depending on whether $\nu X > A$ or $\nu X < A$.

To evaluate $Q(x,y;\nu,M)$ when $X/|y|$ is large and negative, we write, from formula (F-2),

$$\begin{aligned}
 Q(x,y;\nu,M) &= \int_{-\infty}^{\infty} \exp(-i\nu|y|\lambda) \frac{d\lambda}{(\lambda^2+1)^{\frac{3}{2}}} - \int_{-\infty}^{X/|y|} \exp(-i\nu|y|\lambda) \frac{d\lambda}{(\lambda^2+1)^{\frac{3}{2}}} \\
 &= 2F(\nu|y|) - \int_{-X/|y|}^{\infty} \exp(i\nu|y|\lambda) \frac{d\lambda}{(\lambda^2+1)^{\frac{3}{2}}} . \tag{F-19}
 \end{aligned}$$

The evaluation of $F(\alpha)$ has already been considered according to formulae (F-6) and (F-8). The evaluation of

$$\int_{-X/|y|}^{\infty} \exp(i\nu|y|\lambda) \frac{d\lambda}{(\lambda^2+1)^{\frac{3}{2}}} \tag{F-20}$$

for $-X/|y| > 2$ is identical to the evaluation of $Q(x,y;\nu,M)$ for $X/|y| > 2$, apart from a change in the sign of the imaginary part.

Table 1

NUMERICAL VALUES OF APPROXIMATIONS Q_{ij} , $i = 1(1)6$, $j = 1(1)6$, TO THE
 GENERALISED AIRFORCE COEFFICIENTS FOR THE FIN-TAILPLANE CONFIGURATION
 OF EXAMPLE 4.1 $v = 0.3$, $M = 0.866$

| | | | | | |
|--|--|--|--|--|--|
| \hat{Q}'_{11} 0.0551 (0.0564) | \hat{Q}'_{12} -1.3825 (-1.3838) | \hat{Q}'_{13} 0.0372 (0.0382) | \hat{Q}'_{14} -1.1223 (-1.1240) | \hat{Q}'_{15} 0.0340 (0.0351) | \hat{Q}'_{16} -0.8825 (-0.8844) |
| \hat{Q}''_{11} -1.3871 (-1.3887) | \hat{Q}''_{12} -1.7644 (-1.7837) | \hat{Q}''_{13} -1.1197 (-1.1217) | \hat{Q}''_{14} -1.3196 (-1.3357) | \hat{Q}''_{15} -1.2013 (-1.2040) | \hat{Q}''_{16} -1.0135 (-1.0283) |
| \hat{Q}'_{21} 0.0504 (0.0508) | \hat{Q}'_{22} -0.2083 (-0.2037) | \hat{Q}'_{23} 0.0399 (0.0402) | \hat{Q}'_{24} -0.1930 (-0.1893) | \hat{Q}'_{25} 0.0421 (0.0426) | \hat{Q}'_{26} -0.1569 (-0.1539) |
| \hat{Q}''_{21} -0.2329 (-0.2283) | \hat{Q}''_{22} -1.0596 (-1.0667) | \hat{Q}''_{23} -0.2113 (-0.2080) | \hat{Q}''_{24} -0.8280 (-0.8347) | \hat{Q}''_{25} -0.2455 (-0.2423) | \hat{Q}''_{26} -0.6442 (-0.6500) |
| \hat{Q}'_{31} 0.0371 (0.0381) | \hat{Q}'_{32} -1.1198 (-1.1209) | \hat{Q}'_{33} 0.0577 (0.0585) | \hat{Q}'_{34} -1.3610 (-1.3630) | \hat{Q}'_{35} 0.0847 (0.0856) | \hat{Q}'_{36} -1.1705 (-1.1726) |
| \hat{Q}''_{31} -1.1169 (-1.1118) | \hat{Q}''_{32} -1.3154 (-1.3310) | \hat{Q}''_{33} -1.3684 (-1.3703) | \hat{Q}''_{34} -1.7771 (-1.7903) | \hat{Q}''_{35} -1.8537 (-1.8567) | \hat{Q}''_{36} -1.5554 (-1.5680) |
| \hat{Q}'_{41} 0.0396 (0.0399) | \hat{Q}'_{42} -0.1927 (-0.1890) | \hat{Q}'_{43} 0.0502 (0.0504) | \hat{Q}'_{44} -0.2050 (-0.2018) | \hat{Q}'_{45} 0.0689 (0.0691) | \hat{Q}'_{46} -0.1718 (-0.1691) |
| \hat{Q}''_{41} -0.2108 (-0.2073) | \hat{Q}''_{42} -0.8240 (-0.8300) | \hat{Q}''_{43} -0.2298 (-0.2267) | \hat{Q}''_{44} -1.0483 (-1.0530) | \hat{Q}''_{45} -0.2959 (-0.2930) | \hat{Q}''_{46} -0.9086 (-0.9127) |

Table 1 (concluded)

| | | | | | |
|--|--|--|--|--|--|
| \hat{Q}'_{51} 0.0337 (0.0347) | \hat{Q}'_{52} -1.2039 (-1.2052) | \hat{Q}'_{53} 0.0846 (0.0854) | \hat{Q}'_{54} -1.8354 (-1.8379) | \hat{Q}'_{55} 0.1402 (0.1410) | \hat{Q}'_{56} -1.6331 (-1.6359) |
| \hat{Q}''_{51} -1.1955 (-1.1970) | \hat{Q}''_{52} -1.3221 (-1.3383) | \hat{Q}''_{53} -1.8511 (-1.8533) | \hat{Q}''_{54} -2.4929 (-2.5057) | \hat{Q}''_{55} -2.7457 (-2.7493) | \hat{Q}''_{56} -2.2753 (-2.2877) |
| \hat{Q}'_{61} 0.0308 (0.0311) | \hat{Q}'_{62} -0.1564 (-0.1534) | \hat{Q}'_{63} 0.0434 (0.0435) | \hat{Q}'_{64} -0.1716 (-0.1690) | \hat{Q}'_{65} 0.0618 (0.0620) | \hat{Q}'_{66} -0.1447 (-0.1424) |
| \hat{Q}''_{61} -0.1702 (-0.1673) | \hat{Q}''_{62} -0.6391 (-0.6440) | \hat{Q}''_{63} -0.1933 (-0.1907) | \hat{Q}''_{64} -0.9068 (-0.9103) | \hat{Q}''_{65} -0.2536 (-0.2510) | \hat{Q}''_{66} -0.8005 (-0.8033) |

Table 2

NUMERICAL VALUES OF APPROXIMATIONS \hat{Q}_{12} , $i = 1(1)4$, TO THE GENERALISED
 AIRFORCE COEFFICIENTS FOR THE FIN-TAILPLANE CONFIGURATION OF EXAMPLE 4.2
 $M = 0$

| v | 0 | 0.1 | 0.2 | 0.5 | 0.7 | 1.0 |
|------------------|----------------------|----------------------|----------------------|----------------------|----------------------|----------------------|
| \hat{Q}'_{12} | -1.0850 (-1.0865) | -1.0838 (-1.0854) | -1.0815 (-1.0832) | -1.0724 (-1.0748) | -1.0660 (-1.0696) | -1.0571 (-1.0640) |
| \hat{Q}'_{22} | 0.3229 (0.3282) | 0.3228 (0.3280) | 0.3227 (0.3280) | 0.3245 (0.3300) | 0.3278 (0.3331) | 0.3360 (0.3418) |
| \hat{Q}'_{21} | -1.2290 (-1.2306) | -1.2277 (-1.2293) | -1.2250 (-1.2268) | -1.2146 (-1.2172) | -1.2072 (-1.2112) | -1.1969 (-1.2047) |
| \hat{Q}'_{42} | -0.0716 (-0.0717) | -0.0715 (-0.0716) | -0.0714 (-0.0715) | -0.0707 (-0.0708) | -0.0702 (-0.0704) | -0.0694 (-0.0698) |
| \hat{Q}''_{12} | -0.7716 | -0.7782 (-0.774) | -0.7839 (-0.780) | -0.7976 (-0.7944) | -0.8045 (-0.8021) | -0.8122 (-0.8116) |
| \hat{Q}''_{22} | -0.1060 | -0.1040 (-0.104) | -0.1023 (-0.102) | -0.0981 (-0.0980) | -0.0959 (-0.0960) | -0.0929 (-0.0936) |
| \hat{Q}''_{32} | -0.8471 | -0.8546 (-0.849) | -0.8611 (-0.855) | -0.8767 (-0.8716) | -0.8846 (-0.8804) | -0.8936 (-0.8913) |
| \hat{Q}''_{42} | -0.0359 | -0.0364 (-0.036) | -0.0368 (-0.0365) | -0.0378 (-0.0374) | -0.0383 (-0.0379) | -0.0389 (-0.0386) |

Table 3

NUMERICAL VALUES OF APPROXIMATIONS \hat{Q}_{ij} , $i = 1(1)6$, $j = 1(1)6$, TO THE
 GENERALISED AIRFORCE COEFFICIENTS FOR THE FIN-TAILPLANE CONFIGURATION
 OF EXAMPLE 4.3 $\nu = 0.5$, $M = 0.866$

$$m_1 = m'_1 = m_2 = m'_2, \quad n = n'_1 = n'_2 = 3, \quad a_1 = a_2 = 1$$

| | | | | | | |
|---------|------------------|------------------|------------------|------------------|------------------|------------------|
| m_1 | \hat{Q}'_{11} | \hat{Q}'_{12} | \hat{Q}'_{13} | \hat{Q}'_{14} | \hat{Q}'_{15} | \hat{Q}'_{16} |
| (i) 4 | 0.2090 | -2.6194 | 0.1055 | -2.1675 | 0.0097 | -0.0429 |
| (ii) 6 | 0.1973 | -2.6000 | 0.0892 | -2.1514 | -0.0164 | -0.0460 |
| (iii) 9 | 0.1851 | -2.5785 | 0.0744 | -2.1328 | -0.0371 | -0.0481 |
| (iv) 12 | 0.1795 | -2.5686 | 0.0675 | -2.1244 | -0.0469 | -0.0491 |
| (v) 15 | 0.1764 | -2.5632 | 0.0635 | -2.1197 | -0.0525 | -0.0496 |
| (4) | (0.2164) | (-2.0977) | (0.1589) | (-1.7000) | (-0.1529) | (0.0010) |
| m_1 | \hat{Q}''_{11} | \hat{Q}''_{12} | \hat{Q}''_{13} | \hat{Q}''_{14} | \hat{Q}''_{15} | \hat{Q}''_{16} |
| (i) 4 | -2.4784 | -1.7668 | -2.4543 | -1.5850 | -3.2663 | -0.3703 |
| (ii) 6 | -2.4597 | -1.7091 | -2.4147 | -1.5111 | -3.1777 | -0.3498 |
| (iii) 9 | -2.4390 | -1.6467 | -2.3818 | -1.4415 | -3.1155 | -0.3368 |
| (iv) 12 | -2.4289 | -1.6160 | -2.3654 | -1.4069 | -3.0839 | -0.3300 |
| (v) 15 | -2.4232 | -1.5980 | -2.3557 | -1.3863 | -3.0652 | -0.3258 |
| (4) | (-2.0492) | (-1.5608) | (-1.9308) | (-1.3892) | (-2.4498) | (-0.2382) |
| m_1 | \hat{Q}'_{21} | \hat{Q}'_{22} | \hat{Q}'_{23} | \hat{Q}'_{24} | \hat{Q}'_{25} | \hat{Q}'_{26} |
| (i) 4 | 0.0513 | 0.8065 | 0.0968 | 0.4416 | 0.1545 | 0.0178 |
| (ii) 6 | 0.0539 | 0.7715 | 0.0980 | 0.4089 | 0.1517 | 0.0159 |
| (iii) 9 | 0.0543 | 0.7370 | 0.0971 | 0.3770 | 0.1478 | 0.0145 |
| (iv) 12 | 0.0544 | 0.7235 | 0.0967 | 0.3642 | 0.1459 | 0.0138 |
| (v) 15 | 0.0545 | 0.7168 | 0.0966 | 0.3575 | 0.1449 | 0.0134 |
| (4) | (-0.0129) | (0.6847) | (0.0261) | (0.3520) | (0.0529) | (0.0047) |
| m_1 | \hat{Q}''_{21} | \hat{Q}''_{22} | \hat{Q}''_{23} | \hat{Q}''_{24} | \hat{Q}''_{25} | \hat{Q}''_{26} |
| (i) 4 | 0.7286 | -0.7146 | 0.3091 | -0.6771 | 0.0408 | -0.0744 |
| (ii) 6 | 0.6949 | -0.7155 | 0.2767 | -0.6880 | 0.0035 | -0.0758 |
| (iii) 9 | 0.6622 | -0.7090 | 0.2440 | -0.6886 | -0.0364 | -0.0786 |
| (iv) 12 | 0.6494 | -0.7071 | 0.2308 | -0.6899 | -0.0532 | -0.0799 |
| (v) 15 | 0.6429 | -0.7065 | 0.2239 | -0.6912 | -0.0620 | -0.0806 |
| (4) | (0.6370) | (-0.2996) | (0.2978) | (-0.3224) | (0.1406) | (-0.0244) |

Table 3 (continued)

| | | | | | | |
|---------|------------------|------------------|------------------|------------------|------------------|------------------|
| m_1 | \hat{Q}'_{31} | \hat{Q}'_{32} | \hat{Q}'_{33} | \hat{Q}'_{34} | \hat{Q}'_{35} | \hat{Q}'_{36} |
| (i) 4 | 0.0547 | -2.8640 | 0.1376 | -2.6500 | 0.2853 | 0.0639 |
| (ii) 6 | 0.0504 | -2.8421 | 0.1256 | -2.6299 | 0.2600 | 0.0593 |
| (iii) 9 | 0.0421 | -2.8184 | 0.1123 | -2.6087 | 0.2375 | 0.0558 |
| (iv) 12 | 0.0384 | -2.8074 | 0.1061 | -2.5990 | 0.2269 | 0.0541 |
| (v) 15 | 0.0364 | -2.8012 | 0.1026 | -2.5936 | 0.2209 | 0.0532 |
| (4) | (0.0859) | (-2.2202) | (0.1759) | (-2.0574) | (0.3505) | (0.0764) |
| m_1 | \hat{Q}''_{31} | \hat{Q}''_{32} | \hat{Q}''_{33} | \hat{Q}''_{34} | \hat{Q}''_{35} | \hat{Q}''_{36} |
| (i) 4 | -2.7299 | -1.3939 | -4.1302 | -1.6249 | -7.5344 | -1.5793 |
| (ii) 6 | -2.7100 | -1.3708 | -4.0836 | -1.5762 | -7.4264 | -1.5539 |
| (iii) 9 | -2.6879 | -1.3270 | -4.0471 | -1.5192 | -7.3560 | -1.5389 |
| (iv) 12 | -2.6773 | -1.3050 | -4.0291 | -1.4907 | -7.3208 | -1.5309 |
| (v) 15 | -2.6713 | -1.2923 | -4.0187 | -1.4739 | -7.3003 | -1.5263 |
| (4) | (-2.1884) | (-1.2208) | (-3.3254) | (-1.4050) | (-6.0844) | (-1.2782) |
| m_1 | \hat{Q}'_{41} | \hat{Q}'_{42} | \hat{Q}'_{43} | \hat{Q}'_{44} | \hat{Q}'_{45} | \hat{Q}'_{46} |
| (i) 4 | 0.0756 | 0.3422 | 0.1019 | 0.2069 | 0.1505 | 0.0147 |
| (ii) 6 | 0.0752 | 0.3280 | 0.1009 | 0.1907 | 0.1461 | 0.0130 |
| (iii) 9 | 0.0733 | 0.3071 | 0.0984 | 0.1693 | 0.1410 | 0.0117 |
| (iv) 12 | 0.0724 | 0.2993 | 0.0973 | 0.1611 | 0.1388 | 0.0111 |
| (v) 15 | 0.0720 | 0.2958 | 0.0968 | 0.1572 | 0.1377 | 0.0108 |
| (4) | (0.0201) | (0.2922) | (0.0414) | (0.1658) | (0.0661) | (0.0047) |
| m_1 | \hat{Q}''_{41} | \hat{Q}''_{42} | \hat{Q}''_{43} | \hat{Q}''_{44} | \hat{Q}''_{45} | \hat{Q}''_{46} |
| (i) 4 | 0.2971 | -0.7074 | 0.0644 | -0.7222 | -0.1947 | -0.0973 |
| (ii) 6 | 0.2823 | -0.6969 | 0.0496 | -0.7206 | -0.2099 | -0.0964 |
| (iii) 9 | 0.2620 | -0.6813 | 0.0277 | -0.7119 | -0.2377 | -0.0981 |
| (iv) 12 | 0.2544 | -0.6747 | 0.0193 | -0.7085 | -0.2485 | -0.0989 |
| (v) 15 | 0.2510 | -0.6713 | 0.0152 | -0.7070 | -0.2539 | -0.0992 |
| (4) | (0.2648) | (-0.3446) | (0.0954) | (-0.3974) | (-0.0542) | (-0.0444) |

Table 3 (concluded)

| | | | | | | |
|---------|------------------|------------------|------------------|------------------|------------------|------------------|
| m_1 | \hat{Q}'_{51} | \hat{Q}'_{52} | \hat{Q}'_{53} | \hat{Q}'_{54} | \hat{Q}'_{55} | \hat{Q}'_{56} |
| (i) 4 | -0.1194 | -4.2295 | 0.2229 | -4.0619 | 0.7910 | 0.2621 |
| (ii) 6 | -0.1190 | -4.1971 | 0.2110 | -4.0292 | 0.7581 | 0.2544 |
| (iii) 9 | -0.1264 | -4.1619 | 0.1947 | -3.9959 | 0.7262 | 0.2481 |
| (iv) 12 | -0.1298 | -4.1451 | 0.1870 | -3.9803 | 0.7109 | 0.2450 |
| (v) 15 | -0.1314 | -4.1357 | 0.1828 | -3.9715 | 0.7025 | 0.2433 |
| (4) | (-0.0451) | (-3.1942) | (0.2505) | (-3.0975) | (0.7556) | (0.2304) |
| m_1 | \hat{Q}''_{51} | \hat{Q}''_{52} | \hat{Q}''_{53} | \hat{Q}''_{54} | \hat{Q}''_{55} | \hat{Q}''_{56} |
| (i) 4 | -4.0170 | -1.3176 | -7.9151 | -1.9244 | -16.4530 | -4.0306 |
| (ii) 6 | -3.9886 | -1.3140 | -7.8435 | -1.8820 | -16.2848 | -3.9911 |
| (iii) 9 | -3.9564 | -1.2710 | -7.7884 | -1.8183 | -16.1774 | -3.9680 |
| (iv) 12 | -3.9410 | -1.2485 | -7.7614 | -1.7858 | -16.1242 | -3.9560 |
| (v) 15 | -3.9323 | -1.2357 | -7.7458 | -1.7669 | -16.0934 | -3.9490 |
| (4) | (-3.1368) | (-1.1382) | (-6.4412) | (-1.6348) | (-13.6064) | (-3.3820) |
| m_1 | \hat{Q}'_{61} | \hat{Q}'_{62} | \hat{Q}'_{63} | \hat{Q}'_{64} | \hat{Q}'_{65} | \hat{Q}'_{66} |
| (i) 4 | -0.0755 | -0.6358 | 0.0397 | -0.6099 | 0.2394 | 0.0983 |
| (ii) 6 | -0.0745 | -0.6309 | 0.0387 | -0.6043 | 0.2354 | 0.0969 |
| (iii) 9 | -0.0747 | -0.6254 | 0.0370 | -0.5985 | 0.2309 | 0.0957 |
| (iv) 12 | -0.0748 | -0.6226 | 0.0362 | -0.5987 | 0.2286 | 0.0951 |
| (v) 15 | -0.0748 | -0.6210 | 0.0357 | -0.5941 | 0.2274 | 0.0947 |
| (4) | (-0.0563) | (-0.4522) | (0.0334) | (-0.4372) | (0.1889) | (0.0762) |
| m_1 | \hat{Q}''_{61} | \hat{Q}''_{62} | \hat{Q}''_{63} | \hat{Q}''_{64} | \hat{Q}''_{65} | \hat{Q}''_{66} |
| (i) 4 | -0.5908 | 0.0478 | -1.7554 | -0.0606 | -4.2055 | -1.1886 |
| (ii) 6 | -0.5867 | 0.0447 | -1.7443 | -0.0587 | -4.1792 | -1.1824 |
| (iii) 9 | -0.5818 | 0.0472 | -1.7353 | -0.0533 | -4.1615 | -1.1786 |
| (iv) 12 | -0.5793 | 0.0489 | -1.7309 | -0.0503 | -4.1528 | -1.1769 |
| (v) 15 | -0.5780 | 0.0500 | -1.7283 | -0.0485 | -4.1477 | -1.1755 |
| (4) | (-0.4326) | (0.0528) | (-1.4430) | (-0.0326) | (-3.5514) | (-1.0252) |

Table 4

NUMERICAL VALUES OF APPROXIMATIONS \hat{Q}_{ij} , $i = 1(1)3$, $j = 1(1)3$, TO THE
 GENERALISED AIRFORCE COEFFICIENTS FOR THE STARK FIN-TAILPLANE
 CONFIGURATION, EXAMPLE 4.4 $\nu = 0.6$, $M = 0.8$
 $m_1 = m_1' = m_2 = m_2'$, $n = n_1' = n_2'$, $a_1 = a_2 = 1$

| (m_1, n) | $\frac{1}{2\pi} \hat{Q}'_{11}$ | $\frac{\nu}{2\pi} \hat{Q}''_{11}$ | $\frac{1}{2\pi} \hat{Q}'_{12}$ | $\frac{\nu}{2\pi} \hat{Q}''_{12}$ | $\frac{1}{2\pi} \hat{Q}'_{13}$ | $\frac{\nu}{2\pi} \hat{Q}''_{13}$ |
|--------------|--------------------------------|-----------------------------------|--------------------------------|-----------------------------------|--------------------------------|-----------------------------------|
| (i) (4,3) | -0.0614 | -0.5216 | 0.0487 | -0.0257 | 0.0132 | 0.0261 |
| (ii) (6,3) | -0.0714 | -0.5160 | 0.0478 | -0.0270 | 0.0135 | 0.0254 |
| (iii) (9,3) | -0.0775 | -0.5098 | 0.0468 | -0.0277 | 0.0136 | 0.0252 |
| (iv) (12,3) | -0.0802 | -0.5072 | 0.0463 | -0.0279 | 0.0136 | 0.0251 |
| (v) (6,4) | -0.0661 | -0.5202 | 0.0483 | -0.0263 | 0.0134 | 0.0258 |
| (vi) (9,4) | -0.0746 | -0.5158 | 0.0475 | -0.0274 | 0.0135 | 0.0255 |
| (vii) (12,4) | -0.0782 | -0.5141 | 0.0472 | -0.0279 | 0.0136 | 0.0254 |
| (m_1, n) | $\frac{1}{2\pi} \hat{Q}'_{21}$ | $\frac{\nu}{2\pi} \hat{Q}''_{21}$ | $\frac{1}{2\pi} \hat{Q}'_{22}$ | $\frac{\nu}{2\pi} \hat{Q}''_{22}$ | $\frac{1}{2\pi} \hat{Q}'_{23}$ | $\frac{\nu}{2\pi} \hat{Q}''_{23}$ |
| (i) (4,3) | -0.6229 | -0.3927 | 0.0285 | -0.1245 | 0.0165 | -0.0299 |
| (ii) (6,3) | -0.6215 | -0.3856 | 0.0277 | -0.1240 | 0.0165 | -0.0303 |
| (iii) (9,3) | -0.6210 | -0.3792 | 0.0269 | -0.1236 | 0.0165 | -0.0304 |
| (iv) (12,3) | -0.6210 | -0.3763 | 0.0265 | -0.1234 | 0.0165 | -0.0305 |
| (v) (6,4) | -0.6215 | -0.3877 | 0.0280 | -0.1240 | 0.0166 | -0.0302 |
| (vi) (9,4) | -0.6211 | -0.3816 | 0.0272 | -0.1237 | 0.0165 | -0.0303 |
| (vii) (12,4) | -0.6212 | -0.3790 | 0.0268 | -0.1236 | 0.0165 | -0.0304 |
| (m_1, n) | $\frac{1}{2\pi} \hat{Q}'_{31}$ | $\frac{\nu}{2\pi} \hat{Q}''_{31}$ | $\frac{1}{2\pi} \hat{Q}'_{32}$ | $\frac{\nu}{2\pi} \hat{Q}''_{32}$ | $\frac{1}{2\pi} \hat{Q}'_{33}$ | $\frac{\nu}{2\pi} \hat{Q}''_{33}$ |
| (i) (4,3) | -0.1252 | -0.1222 | 0.0149 | -0.0262 | 0.0179 | -0.0502 |
| (ii) (6,3) | -0.1249 | -0.1216 | 0.0148 | -0.0261 | 0.0179 | -0.0502 |
| (iii) (9,3) | -0.1246 | -0.1213 | 0.0147 | -0.0261 | 0.0179 | -0.0502 |
| (iv) (12,3) | -0.1246 | -0.1212 | 0.0147 | -0.0260 | 0.0179 | -0.0502 |
| (v) (6,4) | -0.1252 | -0.1222 | 0.0148 | -0.0262 | 0.0180 | -0.0502 |
| (vi) (9,4) | -0.1249 | -0.1216 | 0.0148 | -0.0261 | 0.0180 | -0.0502 |
| (vii) (12,4) | -0.1249 | -0.1214 | 0.0147 | -0.0261 | 0.0180 | -0.0502 |

Table 5

COMPARISON OF NUMERICAL VALUES OBTAINED BY DIFFERENT WORKERS FOR THE APPROXIMATIONS \hat{Q}_{ij} , $i = 1(1)3$, $j = 1(1)3$, TO THE GENERALISED AIRFORCE COEFFICIENTS FOR THE STARK FIN-TAILPLANE CONFIGURATION, EXAMPLE 4.4 $\nu = 0.6$, $M = 0.8$

| | $\frac{1}{2\pi} \hat{Q}'_{11}$ | $\frac{\nu}{2\pi} \hat{Q}''_{11}$ | $\frac{1}{2\pi} \hat{Q}'_{12}$ | $\frac{\nu}{2\pi} \hat{Q}''_{12}$ | $\frac{1}{2\pi} \hat{Q}'_{13}$ | $\frac{\nu}{2\pi} \hat{Q}''_{13}$ |
|---------------------|--------------------------------|-----------------------------------|--------------------------------|-----------------------------------|--------------------------------|-----------------------------------|
| Stark (Ref 4) | -0.0961 | -0.4811 | 0.0412 | -0.0300 | 0.0125 | 0.0239 |
| Davies (Ref 1) | -0.0846 | -0.5090 | 0.0461 | -0.0283 | 0.0141 | 0.0260 |
| Zwaan | -0.0922 | -0.5155 | 0.0466 | -0.0298 | 0.0145 | 0.0259 |
| Kálmán <i>et al</i> | -0.0837 | -0.5270 | 0.0470 | -0.0278 | 0.0137 | 0.0257 |
| Böhm and Schmid | -0.0999 | -0.5013 | 0.0451 | -0.0311 | 0.0142 | 0.0242 |
| Stark (Ref 8) | -0.1036 | -0.4727 | 0.0406 | -0.0297 | 0.0138 | 0.0252 |
| Davies (present) | -0.0802 | -0.5072 | 0.0463 | -0.0279 | 0.0136 | 0.0251 |
| | $\frac{1}{2\pi} \hat{Q}'_{21}$ | $\frac{\nu}{2\pi} \hat{Q}''_{21}$ | $\frac{1}{2\pi} \hat{Q}'_{22}$ | $\frac{\nu}{2\pi} \hat{Q}''_{22}$ | $\frac{1}{2\pi} \hat{Q}'_{23}$ | $\frac{\nu}{2\pi} \hat{Q}''_{23}$ |
| Stark (Ref 4) | -0.6108 | -0.3625 | 0.0241 | -0.1211 | 0.0158 | -0.0295 |
| Davies (Ref 1) | -0.6224 | -0.3754 | 0.0265 | -0.1234 | 0.0169 | -0.0305 |
| Zwaan | -0.6236 | -0.3728 | 0.0260 | -0.1236 | 0.0168 | -0.0304 |
| Kálmán <i>et al</i> | -0.6270 | -0.3965 | 0.0297 | -0.1260 | 0.0171 | -0.0318 |
| Böhm and Schmid | -0.6202 | -0.3675 | 0.0253 | -0.1229 | 0.0165 | -0.0306 |
| Stark (Ref 8) | -0.6031 | -0.3412 | 0.0227 | -0.1186 | 0.0164 | -0.0302 |
| Davies (present) | -0.6210 | -0.3763 | 0.0265 | -0.1234 | 0.0165 | -0.0305 |
| | $\frac{1}{2\pi} \hat{Q}'_{31}$ | $\frac{\nu}{2\pi} \hat{Q}''_{31}$ | $\frac{1}{2\pi} \hat{Q}'_{32}$ | $\frac{\nu}{2\pi} \hat{Q}''_{32}$ | $\frac{1}{2\pi} \hat{Q}'_{33}$ | $\frac{\nu}{2\pi} \hat{Q}''_{33}$ |
| Stark (Ref 4) | -0.1247 | -0.1151 | 0.0134 | -0.0255 | 0.0179 | -0.0497 |
| Davies (Ref 1) | -0.1248 | -0.1237 | 0.0150 | -0.0262 | 0.0179 | -0.0502 |
| Zwaan | -0.1235 | -0.1217 | 0.0148 | -0.0259 | 0.0179 | -0.0502 |
| Kálmán <i>et al</i> | -0.1270 | -0.1266 | 0.0154 | -0.0269 | 0.0186 | -0.0529 |
| Böhm and Schmid | -0.1240 | -0.1212 | 0.0146 | -0.0260 | 0.0179 | -0.0502 |
| Stark (Ref 8) | -0.1227 | -0.1195 | 0.0145 | -0.0257 | 0.0179 | -0.0502 |
| Davies (present) | -0.1252 | -0.1222 | 0.0148 | -0.0262 | 0.0180 | -0.0502 |

Table 6
NUMERICAL VALUES OF APPROXIMATIONS \hat{Q}'_{ij} , $i = 1(1)6, j = 1(1)6$, TO THE
GENERALISED AIRFORCE COEFFICIENTS FOR THE FIN-TAILPLANE CONFIGURATION
OF EXAMPLE 4.5 FOR A NUMBER OF VALUES OF THE DIHEDRAL ANGLE α

$$v = 0.0000001, M = 0.8$$

$$m_1 = m'_1 = m_2 = m'_2 = 8, n = n'_1 = n'_2 = 5, a_1 = a_2 = 1$$

| | | | | | | |
|-------------------|------------------|------------------|------------------|------------------|------------------|------------------|
| α | \hat{Q}'_{11} | \hat{Q}'_{12} | \hat{Q}'_{13} | \hat{Q}'_{14} | \hat{Q}'_{15} | \hat{Q}'_{16} |
| $-\frac{\pi}{6}$ | 0.00000 | -0.62405 | 0.00000 | 0.00000 | -0.61181 | 0.00000 |
| $-\frac{\pi}{12}$ | 0.00000 | -0.53412 | 0.00000 | 0.00000 | -0.67000 | 0.00000 |
| 0 | 0.00000 | -0.72424 | 0.00000 | 0.00000 | -0.93948 | 0.00000 |
| $\frac{\pi}{12}$ | 0.00000 | -1.20031 | 0.00000 | 0.00000 | -1.42409 | 0.00000 |
| $\frac{\pi}{6}$ | 0.00000 | -1.87483 | 0.00000 | 0.00000 | -2.05029 | 0.00000 |
| α | \hat{Q}''_{11} | \hat{Q}''_{12} | \hat{Q}''_{13} | \hat{Q}''_{14} | \hat{Q}''_{15} | \hat{Q}''_{16} |
| $-\frac{\pi}{6}$ | -0.68283 | -0.85472 | -0.38626 | -0.61181 | -1.07872 | -0.23779 |
| $-\frac{\pi}{12}$ | -0.48625 | -0.63782 | -0.14628 | -0.67000 | -0.82327 | -0.38783 |
| 0 | -0.64138 | -0.60480 | 0.10604 | -0.93948 | -0.79815 | -0.83028 |
| $\frac{\pi}{12}$ | -1.15535 | -0.77021 | 0.35084 | -1.42409 | -1.01726 | -1.55114 |
| $\frac{\pi}{6}$ | -1.92329 | -1.07399 | 0.56804 | -2.05029 | -1.40938 | -2.44287 |
| α | \hat{Q}'_{21} | \hat{Q}'_{22} | \hat{Q}'_{23} | \hat{Q}'_{24} | \hat{Q}'_{25} | \hat{Q}'_{26} |
| $-\frac{\pi}{6}$ | 0.00000 | 0.00856 | 0.00000 | 0.00000 | 0.09819 | 0.00000 |
| $-\frac{\pi}{12}$ | 0.00000 | 0.06994 | 0.00000 | 0.00000 | 0.12782 | 0.00000 |
| 0 | 0.00000 | 0.06144 | 0.00000 | 0.00000 | 0.10335 | 0.00000 |
| $\frac{\pi}{12}$ | 0.00000 | -0.02550 | 0.00000 | 0.00000 | 0.01742 | 0.00000 |
| $\frac{\pi}{6}$ | 0.00000 | -0.17321 | 0.00000 | 0.00000 | -0.11544 | 0.00000 |
| α | \hat{Q}''_{21} | \hat{Q}''_{22} | \hat{Q}''_{23} | \hat{Q}''_{24} | \hat{Q}''_{25} | \hat{Q}''_{26} |
| $-\frac{\pi}{6}$ | -0.04228 | -0.39204 | -0.13016 | 0.09819 | -0.53525 | 0.13871 |
| $-\frac{\pi}{12}$ | 0.04419 | -0.28902 | -0.05514 | 0.12782 | -0.42528 | 0.12508 |
| 0 | 0.04459 | -0.27633 | 0.02674 | 0.10335 | -0.41020 | 0.03470 |
| $\frac{\pi}{12}$ | -0.05140 | -0.36331 | 0.10791 | 0.01742 | -0.49947 | -0.13342 |
| $\frac{\pi}{6}$ | -0.22252 | -0.52509 | 0.18096 | -0.11544 | -0.66759 | -0.35417 |

Table 6 (continued)

| | | | | | | |
|-------------------|------------------|------------------|------------------|------------------|------------------|------------------|
| α | \hat{Q}'_{31} | \hat{Q}'_{32} | \hat{Q}'_{33} | \hat{Q}'_{34} | \hat{Q}'_{35} | \hat{Q}'_{36} |
| $-\frac{\pi}{6}$ | 0.00000 | -0.16208 | 0.00000 | 0.00000 | 0.02073 | 0.00000 |
| $-\frac{\pi}{12}$ | 0.00000 | 0.03131 | 0.00000 | 0.00000 | 0.16041 | 0.00000 |
| 0 | 0.00000 | 0.23816 | 0.00000 | 0.00000 | 0.31637 | 0.00000 |
| $\frac{\pi}{12}$ | 0.00000 | 0.43974 | 0.00000 | 0.00000 | 0.47144 | 0.00000 |
| $\frac{\pi}{6}$ | 0.00000 | 0.61774 | 0.00000 | 0.00000 | 0.60935 | 0.00000 |
| α | \hat{Q}''_{31} | \hat{Q}''_{32} | \hat{Q}''_{33} | \hat{Q}''_{34} | \hat{Q}''_{35} | \hat{Q}''_{36} |
| $-\frac{\pi}{6}$ | -0.29684 | -0.28208 | -0.39635 | 0.02073 | -0.35058 | 0.23426 |
| $-\frac{\pi}{12}$ | -0.05031 | -0.13908 | -0.39338 | 0.16041 | -0.17492 | 0.42469 |
| 0 | 0.20884 | 0.01603 | -0.38954 | 0.31637 | 0.01250 | 0.62770 |
| $\frac{\pi}{12}$ | 0.45925 | 0.16473 | -0.38462 | 0.47144 | 0.19202 | 0.82436 |
| $\frac{\pi}{6}$ | 0.67968 | 0.29078 | -0.37790 | 0.60935 | 0.34589 | 0.99564 |
| α | \hat{Q}'_{41} | \hat{Q}'_{42} | \hat{Q}'_{43} | \hat{Q}'_{44} | \hat{Q}'_{45} | \hat{Q}'_{46} |
| $-\frac{\pi}{6}$ | 0.00000 | -0.90867 | 0.00000 | 0.00000 | -1.32827 | 0.00000 |
| $-\frac{\pi}{12}$ | 0.00000 | -0.91146 | 0.00000 | 0.00000 | -1.41250 | 0.00000 |
| 0 | 0.00000 | -1.10225 | 0.00000 | 0.00000 | -1.63996 | 0.00000 |
| $\frac{\pi}{12}$ | 0.00000 | -1.48117 | 0.00000 | 0.00000 | -2.00949 | 0.00000 |
| $\frac{\pi}{6}$ | 0.00000 | -1.98488 | 0.00000 | 0.00000 | -2.46748 | 0.00000 |
| α | \hat{Q}''_{41} | \hat{Q}''_{42} | \hat{Q}''_{43} | \hat{Q}''_{44} | \hat{Q}''_{45} | \hat{Q}''_{46} |
| $-\frac{\pi}{6}$ | -0.77168 | -1.17238 | -0.19007 | -1.32827 | -1.75847 | -0.71860 |
| $-\frac{\pi}{12}$ | -0.72214 | -1.01700 | -0.03034 | -1.41250 | -1.59089 | -0.88112 |
| 0 | -0.90713 | -0.97759 | 0.13904 | -1.63996 | -1.57332 | -1.24129 |
| $\frac{\pi}{12}$ | -1.32751 | -1.06495 | 0.30408 | -2.00949 | -1.71454 | -1.78525 |
| $\frac{\pi}{6}$ | -1.90774 | -1.24172 | 0.45065 | -2.46748 | -1.96791 | -2.43554 |

Table 6 (concluded)

| | | | | | | |
|-------------------|------------------|------------------|------------------|------------------|------------------|------------------|
| α | \hat{Q}'_{51} | \hat{Q}'_{52} | \hat{Q}'_{53} | \hat{Q}'_{54} | \hat{Q}'_{55} | \hat{Q}'_{56} |
| $-\frac{\pi}{6}$ | 0.00000 | 0.05702 | 0.00000 | 0.00000 | 0.35810 | 0.00000 |
| $-\frac{\pi}{12}$ | 0.00000 | 0.13594 | 0.00000 | 0.00000 | 0.37425 | 0.00000 |
| 0 | 0.00000 | 0.08998 | 0.00000 | 0.00000 | 0.29469 | 0.00000 |
| $\frac{\pi}{12}$ | 0.00000 | -0.09055 | 0.00000 | 0.00000 | 0.11156 | 0.00000 |
| $\frac{\pi}{6}$ | 0.00000 | -0.37082 | 0.00000 | 0.00000 | -0.14602 | 0.00000 |
| α | \hat{Q}''_{51} | \hat{Q}''_{52} | \hat{Q}''_{53} | \hat{Q}''_{54} | \hat{Q}''_{55} | \hat{Q}''_{56} |
| $-\frac{\pi}{6}$ | -0.07313 | -0.51356 | -0.20497 | 0.35810 | -0.72877 | 0.26199 |
| $-\frac{\pi}{12}$ | 0.05353 | -0.38462 | -0.08563 | 0.37425 | -0.58438 | 0.22157 |
| 0 | 0.02494 | -0.38031 | 0.04279 | 0.29469 | -0.57761 | 0.04719 |
| $\frac{\pi}{12}$ | -0.17066 | -0.51047 | 0.16912 | 0.11156 | -0.71894 | -0.25967 |
| $\frac{\pi}{6}$ | -0.49152 | -0.73730 | 0.28226 | -0.14602 | -0.96817 | -0.65308 |
| α | \hat{Q}'_{61} | \hat{Q}'_{62} | \hat{Q}'_{63} | \hat{Q}'_{64} | \hat{Q}'_{65} | \hat{Q}'_{66} |
| $-\frac{\pi}{6}$ | 0.00000 | -0.53429 | 0.00000 | 0.00000 | -0.84080 | 0.00000 |
| $-\frac{\pi}{12}$ | 0.00000 | -0.67929 | 0.00000 | 0.00000 | -1.04615 | 0.00000 |
| 0 | 0.00000 | -1.06792 | 0.00000 | 0.00000 | -1.44222 | 0.00000 |
| $\frac{\pi}{12}$ | 0.00000 | -1.68508 | 0.00000 | 0.00000 | -2.01366 | 0.00000 |
| $\frac{\pi}{6}$ | 0.00000 | -2.43874 | 0.00000 | 0.00000 | -2.68201 | 0.00000 |
| α | \hat{Q}''_{61} | \hat{Q}''_{62} | \hat{Q}''_{63} | \hat{Q}''_{64} | \hat{Q}''_{65} | \hat{Q}''_{66} |
| $-\frac{\pi}{6}$ | -0.38627 | -0.64203 | 0.10710 | -0.84080 | -0.87525 | -0.64137 |
| $-\frac{\pi}{12}$ | -0.50488 | -0.60426 | 0.30063 | -1.04615 | -0.84397 | -0.97993 |
| 0 | -0.92432 | -0.72740 | 0.50432 | -1.44222 | -1.01230 | -1.57225 |
| $\frac{\pi}{12}$ | -1.62806 | -1.00513 | 0.70118 | -2.01366 | -1.37182 | -2.38626 |
| $\frac{\pi}{6}$ | -2.50667 | -1.37268 | 0.87362 | -2.68201 | -1.84642 | -3.31236 |

Table 7
 NUMERICAL VALUES OF APPROXIMATIONS \hat{Q}_{ij} , $i = 1(1)6$, $j = 1(1)6$, TO THE
 GENERALISED AIRFORCE COEFFICIENTS FOR THE FIN-TAILPLANE CONFIGURATION
 OF EXAMPLE 4.5 FOR A NUMBER OF VALUES OF THE DIHEDRAL ANGLE α

$$m_1 = m'_1 = m_2 = m'_2 = 8, \quad n = n'_1 = n'_2 = 5, \quad a_1 = a_2 = 1$$

| α | \hat{Q}'_{11} | \hat{Q}'_{12} | \hat{Q}'_{13} | \hat{Q}'_{14} | \hat{Q}'_{15} | \hat{Q}'_{16} |
|-------------------|------------------|------------------|------------------|------------------|------------------|------------------|
| $-\frac{\pi}{6}$ | 0.86316 | -0.72803 | 0.23278 | 1.11908 | -0.82614 | 0.67984 |
| $-\frac{\pi}{12}$ | 0.61151 | -0.75403 | 0.16616 | 0.86855 | -1.03898 | 0.51260 |
| 0 | 0.47206 | -1.02974 | 0.08260 | 0.71476 | -1.42014 | 0.46169 |
| $\frac{\pi}{12}$ | 0.48237 | -1.53869 | -0.01111 | 0.66888 | -1.93862 | 0.54669 |
| $\frac{\pi}{6}$ | 0.62954 | -2.17176 | -0.10478 | 0.71910 | -2.49889 | 0.74582 |
| α | \hat{Q}''_{11} | \hat{Q}''_{12} | \hat{Q}''_{13} | \hat{Q}''_{14} | \hat{Q}''_{15} | \hat{Q}''_{16} |
| $-\frac{\pi}{6}$ | -0.85842 | -0.92755 | -0.39041 | -0.96496 | -1.15058 | -0.46188 |
| $-\frac{\pi}{12}$ | -0.65143 | -0.67456 | -0.16485 | -0.96767 | -0.87090 | -0.57176 |
| 0 | -0.77614 | -0.62778 | 0.07680 | -1.18020 | -0.84562 | -0.96582 |
| $\frac{\pi}{12}$ | -1.23781 | -0.81706 | 0.30988 | -1.60114 | -1.09325 | -1.62062 |
| $\frac{\pi}{6}$ | -1.92346 | -1.18841 | 0.50956 | -2.14711 | -1.54419 | -2.41756 |
| α | \hat{Q}'_{21} | \hat{Q}'_{22} | \hat{Q}'_{23} | \hat{Q}'_{24} | \hat{Q}'_{25} | \hat{Q}'_{26} |
| $-\frac{\pi}{6}$ | 0.42987 | 0.07760 | 0.13508 | 0.65758 | 0.15887 | 0.34708 |
| $-\frac{\pi}{12}$ | 0.31672 | 0.06785 | 0.08807 | 0.56009 | 0.11164 | 0.29351 |
| 0 | 0.27087 | 0.01483 | 0.03117 | 0.52128 | 0.04529 | 0.30995 |
| $\frac{\pi}{12}$ | 0.30853 | -0.08374 | -0.02885 | 0.54421 | 0.03829 | 0.40035 |
| $\frac{\pi}{6}$ | 0.41568 | -0.20794 | -0.08545 | 0.61499 | -0.12424 | 0.54509 |
| α | \hat{Q}''_{21} | \hat{Q}''_{22} | \hat{Q}''_{23} | \hat{Q}''_{24} | \hat{Q}''_{25} | \hat{Q}''_{26} |
| $-\frac{\pi}{6}$ | -0.11140 | -0.49196 | -0.11928 | -0.04315 | -0.68376 | 0.03386 |
| $-\frac{\pi}{12}$ | -0.03818 | -0.37056 | -0.04706 | -0.00482 | -0.56150 | 0.01847 |
| 0 | -0.04866 | -0.34374 | 0.03499 | -0.02312 | -0.54243 | -0.07610 |
| $\frac{\pi}{12}$ | -0.15449 | -0.42620 | 0.11672 | -0.10630 | -0.63778 | -0.24936 |
| $\frac{\pi}{6}$ | -0.33006 | -0.59357 | 0.18817 | -0.23546 | -0.81927 | -0.46959 |

Table 7 (continued)

| | | | | | | |
|-------------------|------------------|------------------|------------------|------------------|------------------|------------------|
| α | \hat{Q}'_{31} | \hat{Q}'_{32} | \hat{Q}'_{33} | \hat{Q}'_{34} | \hat{Q}'_{35} | \hat{Q}'_{36} |
| $-\frac{\pi}{6}$ | 0.24249 | -0.08545 | 0.13274 | 0.28146 | 0.12931 | 0.10833 |
| $-\frac{\pi}{12}$ | 0.16081 | 0.08286 | 0.13566 | 0.20519 | 0.23680 | 0.03093 |
| 0 | 0.07280 | 0.26402 | 0.13944 | 0.13664 | 0.35498 | -0.04865 |
| $\frac{\pi}{12}$ | -0.01825 | 0.43132 | 0.14496 | 0.07211 | 0.46039 | -0.13054 |
| $\frac{\pi}{6}$ | -0.10537 | 0.56437 | 0.14974 | 0.01252 | 0.53770 | -0.20772 |
| α | \hat{Q}''_{31} | \hat{Q}''_{32} | \hat{Q}''_{33} | \hat{Q}''_{34} | \hat{Q}''_{35} | \hat{Q}''_{36} |
| $-\frac{\pi}{6}$ | -0.34264 | -0.30121 | -0.39582 | -0.08131 | -0.36091 | 0.17102 |
| $-\frac{\pi}{12}$ | -0.09860 | -0.13856 | -0.39534 | 0.06921 | -0.16411 | 0.36602 |
| 0 | 0.15874 | 0.03749 | -0.39134 | 0.23270 | 0.04294 | 0.57021 |
| $\frac{\pi}{12}$ | 0.40259 | 0.21056 | -0.38380 | 0.38817 | 0.24265 | 0.76036 |
| $\frac{\pi}{6}$ | 0.60844 | 0.36336 | -0.37184 | 0.51798 | 0.41635 | 0.91489 |
| α | \hat{Q}'_{41} | \hat{Q}'_{42} | \hat{Q}'_{43} | \hat{Q}'_{44} | \hat{Q}'_{45} | \hat{Q}'_{46} |
| $-\frac{\pi}{6}$ | 0.99212 | -1.29326 | 0.26671 | 2.05707 | -2.28900 | 0.95614 |
| $-\frac{\pi}{12}$ | 0.71481 | -1.40524 | 0.21416 | 1.81109 | -2.51439 | 0.76081 |
| 0 | 0.51580 | -1.65111 | 0.14200 | 1.63821 | -2.82628 | 0.65653 |
| $\frac{\pi}{12}$ | 0.44398 | -2.02139 | 0.06099 | 1.56051 | -3.20084 | 0.66922 |
| $\frac{\pi}{6}$ | 0.49713 | -2.45122 | -0.01855 | 1.57247 | -3.57958 | 0.78535 |
| α | \hat{Q}''_{41} | \hat{Q}''_{42} | \hat{Q}''_{43} | \hat{Q}''_{44} | \hat{Q}''_{45} | \hat{Q}''_{46} |
| $-\frac{\pi}{6}$ | -1.06608 | -1.22722 | -0.21164 | -1.93734 | -1.80581 | -1.08051 |
| $-\frac{\pi}{12}$ | -1.00579 | -1.01177 | -0.08125 | -1.97023 | -1.59387 | -1.18868 |
| 0 | -1.13600 | -0.93061 | 0.06842 | -2.12574 | -1.54548 | -1.47097 |
| $\frac{\pi}{12}$ | -1.47021 | -1.01887 | 0.21897 | -2.40971 | -1.68816 | -1.91901 |
| $\frac{\pi}{6}$ | -1.94142 | -1.24617 | 0.35111 | -2.77193 | -1.97934 | -2.45646 |

Table 7 (concluded)

| | | | | | | |
|-------------------|------------------|------------------|------------------|------------------|------------------|------------------|
| α | \hat{Q}'_{51} | \hat{Q}'_{52} | \hat{Q}'_{53} | \hat{Q}'_{54} | \hat{Q}'_{55} | \hat{Q}'_{56} |
| $-\frac{\pi}{6}$ | 0.61760 | 0.15277 | 0.16919 | 0.77910 | 0.59006 | 0.49249 |
| $-\frac{\pi}{12}$ | 0.47051 | 0.12409 | 0.11775 | 0.64036 | 0.48736 | 0.40917 |
| 0 | 0.39977 | -0.00216 | 0.05208 | 0.56883 | 0.32660 | 0.40846 |
| $\frac{\pi}{12}$ | 0.43091 | -0.21985 | -0.02014 | 0.57239 | 0.12068 | 0.50060 |
| $\frac{\pi}{6}$ | 0.55178 | -0.48443 | -0.09037 | 0.63864 | -0.09337 | 0.66561 |
| α | \hat{Q}''_{51} | \hat{Q}''_{52} | \hat{Q}''_{53} | \hat{Q}''_{54} | \hat{Q}''_{55} | \hat{Q}''_{56} |
| $-\frac{\pi}{6}$ | -0.7598 | -0.66776 | -0.18410 | 0.17568 | -0.97336 | 0.10715 |
| $-\frac{\pi}{12}$ | -0.07593 | -0.51223 | -0.07078 | 0.19792 | -0.81075 | 0.05946 |
| 0 | -0.12515 | -0.48094 | 0.05415 | 0.12356 | -0.79144 | -0.12141 |
| $\frac{\pi}{12}$ | -0.33266 | -0.59447 | 0.17688 | -0.05274 | -0.93060 | -0.42887 |
| $\frac{\pi}{6}$ | -0.64944 | -0.82112 | 0.28334 | -0.29511 | -1.18873 | -0.80743 |
| α | \hat{Q}'_{61} | \hat{Q}'_{62} | \hat{Q}'_{63} | \hat{Q}'_{64} | \hat{Q}'_{65} | \hat{Q}'_{66} |
| $-\frac{\pi}{6}$ | 0.64304 | -0.80120 | 0.09794 | 1.05173 | -1.37011 | 0.64686 |
| $-\frac{\pi}{12}$ | 0.48178 | -1.03141 | 0.03844 | 0.89503 | -1.68640 | 0.55787 |
| 0 | 0.41840 | -1.46822 | -0.03903 | 0.81181 | -2.14319 | 0.57012 |
| $\frac{\pi}{12}$ | 0.48931 | -2.07101 | -0.12764 | 0.82055 | -2.68947 | 0.70483 |
| $\frac{\pi}{6}$ | 0.67986 | -2.73175 | -0.21524 | 0.91200 | -3.23248 | 0.93795 |
| α | \hat{Q}''_{61} | \hat{Q}''_{62} | \hat{Q}''_{63} | \hat{Q}''_{64} | \hat{Q}''_{65} | \hat{Q}''_{66} |
| $-\frac{\pi}{6}$ | -0.54513 | -0.69307 | 0.09878 | -1.15315 | -0.93473 | -0.83640 |
| $-\frac{\pi}{12}$ | -0.65413 | -0.63338 | 0.27592 | -1.32078 | -0.89567 | -1.13907 |
| 0 | -1.03737 | -0.75469 | 0.46586 | -1.66742 | -1.07257 | -1.67825 |
| $\frac{\pi}{12}$ | -1.67546 | -1.07043 | 0.64761 | -2.17284 | -1.46954 | -2.41455 |
| $\frac{\pi}{6}$ | -2.45369 | -1.52105 | 0.79887 | -2.75252 | -2.01089 | -3.22856 |

Table 8
NUMERICAL VALUES OF APPROXIMATIONS \hat{Q}_{ij} , $i = 1(1)6, j = 1(1)6$, TO THE
GENERALISED AIRFORCE COEFFICIENTS FOR THE FIN-TAILPLANE CONFIGURATION
OF EXAMPLE 4.5 WITH DIHEDRAL ANGLE $\alpha = 0$ AND $M = 0.8$ FOR A NUMBER
OF VALUES OF FREQUENCY PARAMETER ν
 $m_1 = m'_1 = m_2 = m'_2 = 8, n = n'_1 = n'_2 = 5, a_1 = a_2 = 1$

| ν | \hat{Q}'_{11} | \hat{Q}'_{12} | \hat{Q}'_{13} | \hat{Q}'_{14} | \hat{Q}'_{15} | \hat{Q}'_{16} |
|---------------------|------------------------|------------------------|----------------------|------------------|------------------|------------------|
| 0.000001 (0.001) | 0.00000 (0.0) | -0.72424 (-0.71015) | 0.00000 (0.0) | 0.00000 | -0.93948 | 0.00000 |
| 0.25 | 0.01278 | -0.72618 | 0.00233 | 0.01745 | -0.94166 | 0.01189 |
| 0.50 | 0.05431 | -0.73931 | 0.00908 | 0.07623 | -0.95947 | 0.05189 |
| 0.75 (0.75) | 0.12734 (0.12461) | -0.77054 (-0.74337) | 0.02068 (0.01857) | 0.18342 | -1.00431 | 0.12346 |
| 1.00 | 0.22937 | -0.82760 | 0.03819 | 0.33836 | -1.09028 | 0.22359 |
| 1.25 (1.25) | 0.34975 (0.34656) | -0.91603 (-0.85006) | 0.06072 (0.05265) | 0.52590 | -1.23028 | 0.34128 |
| 1.50 (1.50) | 0.47206 (0.47876) | -1.02974 (-0.93238) | 0.08260 (0.07179) | 0.71476 | -1.42014 | 0.46169 |
| ν | \hat{Q}''_{11} | \hat{Q}''_{12} | \hat{Q}''_{13} | \hat{Q}''_{14} | \hat{Q}''_{15} | \hat{Q}''_{16} |
| 0.000001 (0.001) | -0.64138 (-0.62546) | -0.60480 (-0.59509) | 0.10604 (0.10715) | -0.93948 | -0.79815 | -0.83028 |
| 0.25 | -0.64019 | -0.61953 | 0.10516 | -0.93613 | -0.82079 | -0.82765 |
| 0.50 | -0.64394 | -0.63353 | 0.10363 | -0.93951 | -0.84364 | -0.82983 |
| 0.75 (0.75) | -0.65831 (-0.63600) | -0.64618 (-0.63043) | 0.10150 (0.10238) | -0.96060 | -0.86577 | -0.84398 |
| 1.00 | -0.68655 | -0.65376 | 0.09733 | -1.00726 | -0.88132 | -0.87316 |
| 1.25 (1.25) | -0.72816 (0.68867) | -0.64950 (-0.63133) | 0.08907 (0.09181) | -1.08282 | -0.87853 | -0.91589 |
| 1.50 (1.50) | -0.77614 (-0.72606) | -0.62778 (-0.61580) | 0.07680 (0.08232) | -1.18020 | -0.84491 | -0.96523 |

Table 8 (continued)

| ν | \hat{Q}'_{21} | \hat{Q}'_{22} | \hat{Q}'_{23} | \hat{Q}'_{24} | \hat{Q}'_{25} | \hat{Q}'_{26} |
|----------------------|------------------------|------------------------|-----------------------|------------------|------------------|------------------|
| 0.0000001 (0.001) | 0.00000 (0.0) | 0.06144 (0.05719) | 0.00000 (0.0) | 0.00000 | 0.10335 | 0.00000 |
| 0.25 | 0.00770 | 0.06358 | -0.00026 | 0.01305 | 0.10729 | 0.00946 |
| 0.50 | 0.03110 | 0.06945 | -0.00062 | 0.05305 | 0.11837 | 0.03790 |
| 0.75 (0.75) | 0.07132 (0.06459) | 0.07541 (0.06910) | 0.00027 (-0.00010) | 0.12328 | 0.13127 | 0.08565 |
| 1.00 | 0.12878 | 0.07427 | 0.00494 | 0.22779 | 0.13465 | 0.15165 |
| 1.25 (1.25) | 0.19939 (0.17689) | 0.05602 (0.05735) | 0.01575 (0.01223) | 0.36551 | 0.11084 | 0.23028 |
| 1.50 (1.50) | 0.27087 (0.24192) | 0.01483 (0.03143) | 0.03117 (0.02415) | 0.52128 | 0.04529 | 0.30995 |
| ν | \hat{Q}''_{21} | \hat{Q}''_{22} | \hat{Q}''_{23} | \hat{Q}''_{24} | \hat{Q}''_{25} | \hat{Q}''_{26} |
| 0.0000001 (0.001) | 0.04459 (0.04140) | -0.27633 (-0.26402) | 0.02674 (0.02662) | 0.10335 | -0.41020 | 0.03470 |
| 0.25 | 0.04301 | -0.27820 | 0.02759 | 0.10177 | -0.41347 | 0.03228 |
| 0.50 | 0.03834 | -0.28684 | 0.03001 | 0.09737 | -0.42799 | 0.02526 |
| 0.75 (0.75) | 0.02918 (0.02703) | -0.30140 (-0.28278) | 0.03369 (0.03257) | 0.08794 | -0.45312 | 0.01234 |
| 1.00 | 0.01276 | -0.31973 | 0.03740 | 0.06846 | -0.48648 | -0.00864 |
| 1.25 (1.25) | -0.01359 (-0.00797) | -0.33657 (-0.30623) | 0.03862 (0.03664) | 0.03229 | -0.52076 | -0.03896 |
| 1.50 (1.50) | -0.04866 (-0.03476) | -0.34374 (-0.31053) | 0.03499 (0.03429) | -0.02353 | -0.54315 | -0.07678 |

Table 8 (continued)

| | | | | | | |
|----------------------|----------------------|----------------------|------------------------|------------------|------------------|------------------|
| v | \hat{Q}'_{31} | \hat{Q}'_{32} | \hat{Q}'_{33} | \hat{Q}'_{34} | \hat{Q}'_{35} | \hat{Q}'_{36} |
| 0.0000001 (0.001) | 0.00000 (0.0) | 0.23816 (0.23287) | 0.00000 (0.0) | 0.00000 | 0.31637 | 0.00000 |
| 0.25 | 0.00522 | 0.23730 | 0.00285 | 0.00947 | 0.31489 | 0.00353 |
| 0.50 | 0.01803 | 0.23744 | 0.01224 | 0.03270 | 0.31464 | 0.00983 |
| 0.75 (0.75) | 0.03385 (0.03112) | 0.23992 (0.23324) | 0.02964 (0.03023) | 0.06149 | 0.31785 | 0.01186 |
| 1.00 | 0.04928 | 0.24507 | 0.05632 | 0.08989 | 0.32531 | 0.00427 |
| 1.25 (1.25) | 0.06252 (0.05611) | 0.25302 (0.24358) | 0.09298 (0.09414) | 0.11508 | 0.33751 | -0.01573 |
| 1.50 (1.50) | 0.07280 (0.06420) | 0.26402 (0.25290) | 0.13944 (0.14071) | 0.13664 | 0.35498 | -0.04865 |
| v | \hat{Q}''_{31} | \hat{Q}''_{32} | \hat{Q}''_{33} | \hat{Q}''_{34} | \hat{Q}''_{35} | \hat{Q}''_{36} |
| 0.0000001 (0.001) | 0.20884 (0.20300) | 0.01603 (0.01969) | -0.38954 (-0.38501) | 0.31637 | 0.01250 | 0.62770 |
| 0.25 | 0.20401 | 0.02159 | -0.38857 | 0.30775 | 0.02091 | 0.62089 |
| 0.50 | 0.19367 | 0.02631 | -0.38665 | 0.28941 | 0.02820 | 0.60647 |
| 0.75 (0.75) | 0.18198 (0.17714) | 0.02993 (0.03325) | -0.38508 (-0.38026) | 0.26900 | 0.03375 | 0.59084 |
| 1.00 | 0.17152 | 0.03273 | -0.38484 | 0.25132 | 0.03783 | 0.57817 |
| 1.25 (1.25) | 0.16360 (0.15925) | 0.03510 (0.03856) | -0.38673 (0.38108) | 0.23885 | 0.04078 | 0.57087 |
| 1.50 (1.50) | 0.15874 (0.15459) | 0.03749 (0.04104) | -0.39134 (-0.38487) | 0.23270 | 0.04294 | 0.57021 |

Table 8 (continued)

| | | | | | | |
|-----------|------------------|------------------|------------------|------------------|------------------|------------------|
| v | \hat{Q}'_{41} | \hat{Q}'_{42} | \hat{Q}'_{43} | \hat{Q}'_{44} | \hat{Q}'_{45} | \hat{Q}'_{46} |
| 0.0000001 | 0.00000 | -1.10225 | 0.00000 | 0.00000 | -1.63996 | 0.00000 |
| 0.25 | 0.01698 | -1.10770 | 0.00427 | 0.04540 | -1.65423 | 0.01990 |
| 0.50 | 0.07182 | -1.13664 | 0.01698 | 0.19076 | -1.71699 | 0.08497 |
| 0.75 | 0.16518 | -1.20095 | 0.03946 | 0.44359 | -1.84975 | 0.19635 |
| 1.00 | 0.28693 | -1.31165 | 0.07273 | 0.79563 | -2.07656 | 0.34330 |
| 1.25 | 0.41307 | -1.47009 | 0.11178 | 1.21236 | -2.41116 | 0.50374 |
| 1.50 | 0.51580 | -1.65111 | 0.14200 | 1.63821 | -2.82628 | 0.65653 |
| v | \hat{Q}''_{41} | \hat{Q}''_{42} | \hat{Q}''_{43} | \hat{Q}''_{44} | \hat{Q}''_{45} | \hat{Q}''_{46} |
| 0.0000001 | -0.90713 | -0.97759 | 0.13904 | -1.63996 | -1.57332 | -1.24129 |
| 0.25 | -0.90710 | -1.00119 | 0.13756 | -1.63870 | -1.61081 | -1.23952 |
| 0.50 | -0.91857 | -1.02016 | 0.13455 | -1.65657 | -1.64585 | -1.24988 |
| 0.75 | -0.94929 | -1.03193 | 0.12896 | -1.71026 | -1.67415 | -1.28149 |
| 1.00 | -1.00168 | -1.02789 | 0.11719 | -1.81013 | -1.68121 | -1.33534 |
| 1.25 | -1.06984 | -0.99588 | 0.09604 | -1.95575 | -1.64400 | -1.40382 |
| 1.50 | -1.13600 | -0.93061 | 0.06842 | -2.12574 | -1.54548 | -1.47097 |
| v | \hat{Q}'_{51} | \hat{Q}'_{52} | \hat{Q}'_{53} | \hat{Q}'_{54} | \hat{Q}'_{55} | \hat{Q}'_{56} |
| 0.0000001 | 0.00000 | 0.08998 | 0.00000 | 0.00000 | 0.29469 | 0.00000 |
| 0.25 | 0.01156 | 0.09310 | -0.00041 | 0.01369 | 0.30450 | 0.01293 |
| 0.50 | 0.04673 | 0.10184 | -0.00097 | 0.05608 | 0.33331 | 0.05176 |
| 0.75 | 0.10739 | 0.10991 | 0.00063 | 0.13254 | 0.37233 | 0.11707 |
| 1.00 | 0.19394 | 0.10492 | 0.00867 | 0.24944 | 0.40243 | 0.20667 |
| 1.25 | 0.29860 | 0.07027 | 0.02694 | 0.40379 | 0.39447 | 0.31036 |
| 1.50 | 0.39977 | -0.00216 | 0.05208 | 0.56883 | 0.32660 | 0.40846 |
| v | \hat{Q}''_{51} | \hat{Q}''_{52} | \hat{Q}''_{53} | \hat{Q}''_{54} | \hat{Q}''_{55} | \hat{Q}''_{56} |
| 0.0000001 | 0.02494 | -0.38031 | 0.04279 | 0.29469 | -0.57761 | 0.04719 |
| 0.25 | 0.02238 | -0.38228 | 0.04418 | 0.29288 | -0.58145 | 0.04343 |
| 0.50 | 0.01511 | -0.39607 | 0.04813 | 0.28860 | -0.60515 | 0.03297 |
| 0.75 | 0.00054 | -0.41959 | 0.05412 | 0.27806 | -0.64689 | 0.01338 |
| 1.00 | -0.02607 | -0.44865 | 0.06000 | 0.25284 | -0.70221 | -0.01894 |
| 1.25 | -0.06895 | -0.47376 | 0.06130 | 0.20227 | -0.75807 | -0.06559 |
| 1.50 | -0.12515 | -0.48094 | 0.05415 | 0.12356 | -0.79144 | -0.12141 |

Table 8 (concluded)

| ν | \hat{Q}'_{61} | \hat{Q}'_{62} | \hat{Q}'_{63} | \hat{Q}'_{64} | \hat{Q}'_{65} | \hat{Q}'_{66} |
|-----------|------------------|------------------|------------------|------------------|------------------|------------------|
| 0.0000001 | 0.00000 | -1.06792 | 0.00000 | 0.00000 | -1.44222 | 0.00000 |
| 0.25 | 0.00888 | -1.06992 | 0.00002 | 0.01505 | -1.44580 | 0.01072 |
| 0.50 | 0.04181 | -1.08739 | -0.00095 | 0.07260 | -1.47433 | 0.05183 |
| 0.75 | 0.10560 | -1.13003 | -0.00369 | 0.18816 | -1.54428 | 0.13329 |
| 1.00 | 0.19914 | -1.20706 | -0.00834 | 0.36506 | -1.67358 | 0.25531 |
| 1.25 | 0.30980 | -1.32340 | -0.02759 | 0.58562 | -1.87638 | 0.40643 |
| 1.50 | 0.41840 | -1.46822 | -0.03903 | 0.81181 | -2.14319 | 0.57012 |
| ν | \hat{Q}''_{61} | \hat{Q}''_{62} | \hat{Q}''_{63} | \hat{Q}''_{64} | \hat{Q}''_{65} | \hat{Q}''_{66} |
| 0.0000001 | -0.92432 | -0.72740 | 0.50432 | -1.44222 | -1.01230 | -1.57225 |
| 0.25 | -0.91864 | -0.75014 | 0.50232 | -1.43078 | -1.04744 | -1.56305 |
| 0.50 | -0.91420 | -0.77045 | 0.49850 | -1.41966 | -1.08118 | -1.55309 |
| 0.75 | -0.92153 | -0.78691 | 0.49394 | -1.42915 | -1.11116 | -1.55657 |
| 1.00 | -0.94636 | -0.79469 | 0.48759 | -1.47273 | -1.12939 | -1.58032 |
| 1.25 | -0.98811 | -0.78574 | 0.47778 | -1.55543 | -1.12113 | -1.62361 |
| 1.50 | -1.03737 | -0.75469 | 0.46586 | -1.66742 | -1.07257 | -1.67825 |

Table 9

NUMERICAL VALUES OF APPROXIMATIONS \hat{Q}_{ij} , $i=1(1)3$, $j=1(1)3$, TO THE
 GENERALISED AIRFORCE COEFFICIENTS FOR THE FIN-TAILPLANE CONFIGURATION OF
 EXAMPLE 4.5 WITH DIHEDRAL ANGLE $\alpha = 0$, $M = 0.8$ AND FREQUENCY PARAMETER
 $\nu = 1.5$ WITH $m_1' = m_1 = m_2' = m_2$, $n_1' = n_1 = n_2' = n$, $a_1 = a_2 = 1$
 AND A NUMBER OF COMBINATIONS OF VALUES OF m_1 AND n

| m_1 | n | \hat{Q}_{11}' | \hat{Q}_{12}' | \hat{Q}_{13}' | \hat{Q}_{11}'' | \hat{Q}_{12}'' | \hat{Q}_{13}'' |
|-------|-----|-----------------|-----------------|-----------------|------------------|------------------|------------------|
| 3 | 3 | 0.50135 | -0.94306 | 0.09438 | -0.76001 | -0.63726 | 0.08305 |
| 4 | 3 | 0.50112 | -0.96535 | 0.07411 | -0.75728 | -0.64034 | 0.09777 |
| 5 | 3 | 0.51094 | -0.96933 | 0.07575 | -0.76187 | -0.65037 | 0.08815 |
| 6 | 3 | 0.50814 | -0.96007 | 0.07987 | -0.75679 | -0.64806 | 0.08826 |
| 7 | 3 | 0.50462 | -0.95683 | 0.07968 | -0.75477 | -0.64596 | 0.08893 |
| 8 | 3 | 0.50421 | -0.95633 | 0.07891 | -0.75474 | -0.64586 | 0.08845 |
| 9 | 3 | 0.50484 | -0.95610 | 0.07885 | -0.75475 | -0.64613 | 0.08807 |
| 10 | 3 | 0.50587 | -0.95600 | 0.07877 | -0.75466 | -0.64651 | 0.08767 |
| 3 | 4 | 0.47369 | -1.00921 | 0.09651 | -0.78425 | -0.61907 | 0.07113 |
| 4 | 4 | 0.46683 | -1.01147 | 0.07860 | -0.76849 | -0.61865 | 0.08674 |
| 5 | 4 | 0.47015 | -1.01689 | 0.07773 | -0.77147 | -0.62567 | 0.07735 |
| 6 | 4 | 0.47912 | -1.02286 | 0.08213 | -0.77542 | -0.63215 | 0.07827 |
| 7 | 4 | 0.47999 | -1.02392 | 0.08369 | -0.77590 | -0.63384 | 0.07968 |
| 8 | 4 | 0.47813 | -1.02289 | 0.08410 | -0.77535 | -0.63375 | 0.07975 |
| 9 | 4 | 0.47688 | -1.02237 | 0.08481 | -0.77522 | -0.63359 | 0.08002 |
| 10 | 4 | 0.47644 | -1.02249 | 0.08522 | -0.77548 | -0.63370 | 0.08022 |
| 3 | 5 | 0.45948 | -1.00589 | 0.09650 | -0.77957 | -0.61116 | 0.06891 |
| 4 | 5 | 0.46399 | -1.02160 | 0.07882 | -0.77225 | -0.61604 | 0.08407 |
| 5 | 5 | 0.46174 | -1.02079 | 0.07767 | -0.77156 | -0.61951 | 0.07510 |
| 6 | 5 | 0.46537 | -1.02103 | 0.08178 | -0.77164 | -0.62254 | 0.07548 |
| 7 | 5 | 0.46934 | -1.02610 | 0.08263 | -0.77409 | -0.62548 | 0.07676 |
| 8 | 5 | 0.47206 | -1.02974 | 0.08260 | -0.77614 | -0.62778 | 0.07670 |
| 9 | 5 | 0.47200 | -1.03023 | 0.08327 | -0.77631 | -0.62826 | 0.07709 |
| 10 | 5 | 0.47110 | -1.03016 | 0.08369 | -0.77620 | -0.62813 | 0.07731 |

Table 9 (continued)

| m_1 | n | \hat{Q}'_{11} | \hat{Q}'_{12} | \hat{Q}'_{13} | \hat{Q}''_{11} | \hat{Q}''_{12} | \hat{Q}''_{13} |
|-------|-----|-----------------|-----------------|-----------------|------------------|------------------|------------------|
| 3 | 6 | 0.45257 | -1.00305 | 0.09739 | -0.77747 | -0.60951 | 0.06769 |
| 4 | 6 | 0.45939 | -1.02001 | 0.07884 | -0.77089 | -0.61371 | 0.08317 |
| 5 | 6 | 0.46112 | -1.02178 | 0.07748 | -0.77186 | -0.61868 | 0.07421 |
| 6 | 6 | 0.46233 | -1.02053 | 0.08140 | -0.77115 | -0.62013 | 0.07448 |
| 7 | 6 | 0.46313 | -1.02275 | 0.08238 | -0.77186 | -0.62127 | 0.07562 |
| 8 | 6 | 0.46557 | -1.02590 | 0.08236 | -0.77343 | -0.62315 | 0.07561 |
| 9 | 6 | 0.46805 | -1.02860 | 0.08283 | -0.77489 | -0.62484 | 0.07589 |
| 10 | 6 | 0.46918 | -1.02991 | 0.08309 | -0.77555 | -0.62576 | 0.07607 |
| 3 | 7 | 0.45460 | -1.00402 | 0.09751 | -0.77908 | -0.61224 | 0.06807 |
| 4 | 7 | 0.45533 | -1.01469 | 0.07880 | -0.76824 | -0.61279 | 0.08309 |
| 5 | 7 | 0.46016 | -1.01963 | 0.07732 | -0.77101 | -0.61850 | 0.07411 |
| 6 | 7 | 0.46254 | -1.01886 | 0.08111 | -0.77049 | -0.62016 | 0.07422 |
| 7 | 7 | 0.46244 | -1.02063 | 0.08194 | -0.77098 | -0.62066 | 0.07532 |
| 8 | 7 | 0.46318 | -1.02238 | 0.08190 | -0.77179 | -0.62156 | 0.07526 |
| 9 | 7 | 0.46444 | -1.02405 | 0.08243 | -0.77258 | -0.62247 | 0.07552 |
| 10 | 7 | 0.46600 | -1.02595 | 0.08273 | -0.77354 | -0.62348 | 0.07569 |
| 3 | 8 | 0.45502 | -1.00350 | 0.09808 | -0.77954 | -0.61464 | 0.06845 |
| 4 | 8 | 0.45559 | -1.01423 | 0.07888 | -0.76854 | -0.61417 | 0.08322 |
| 5 | 8 | 0.45783 | -1.01689 | 0.07744 | -0.76974 | -0.61805 | 0.07409 |
| 6 | 8 | 0.46235 | -1.01822 | 0.08107 | -0.77046 | -0.62045 | 0.07419 |
| 7 | 8 | 0.46247 | -1.01971 | 0.08190 | -0.77066 | -0.62082 | 0.07522 |
| 8 | 8 | 0.46294 | -1.02130 | 0.08178 | -0.77136 | -0.62148 | 0.07510 |
| 9 | 8 | 0.46352 | -1.02236 | 0.08226 | -0.77184 | -0.62199 | 0.07532 |
| 10 | 8 | 0.46420 | -1.02345 | 0.08253 | -0.77234 | -0.62250 | 0.07547 |
| | | \hat{Q}'_{21} | \hat{Q}'_{22} | \hat{Q}'_{23} | \hat{Q}''_{21} | \hat{Q}''_{22} | \hat{Q}''_{23} |
| 3 | 3 | 0.26061 | 0.07252 | 0.02281 | -0.02229 | -0.30714 | 0.04233 |
| 4 | 3 | 0.26005 | 0.07054 | 0.01216 | -0.02005 | -0.31285 | 0.03960 |
| 5 | 3 | 0.26445 | 0.07381 | 0.01622 | -0.01822 | -0.31545 | 0.03676 |
| 6 | 3 | 0.26147 | 0.07181 | 0.01752 | -0.01887 | -0.31258 | 0.03765 |
| 7 | 3 | 0.25968 | 0.06996 | 0.01722 | -0.01980 | -0.31116 | 0.03780 |
| 8 | 3 | 0.25958 | 0.06957 | 0.01717 | -0.02202 | -0.31094 | 0.03741 |
| 9 | 3 | 0.25973 | 0.06976 | 0.01731 | -0.01981 | -0.31094 | 0.03730 |
| 10 | 3 | 0.25986 | 0.07016 | 0.01737 | -0.01941 | -0.31101 | 0.03721 |

Table 9 (continued)

| m_1 | n | \hat{Q}'_{21} | \hat{Q}'_{22} | \hat{Q}'_{23} | \hat{Q}''_{21} | \hat{Q}''_{22} | \hat{Q}''_{23} |
|-------|-----|-----------------|-----------------|-----------------|------------------|------------------|------------------|
| 3 | 4 | 0.27181 | 0.02225 | 0.03660 | -0.04785 | -0.33228 | 0.03861 |
| 4 | 4 | 0.26524 | 0.01963 | 0.02545 | -0.04703 | -0.33462 | 0.03837 |
| 5 | 4 | 0.26887 | 0.02201 | 0.02780 | -0.04659 | -0.33913 | 0.03467 |
| 6 | 4 | 0.27339 | 0.02628 | 0.02913 | -0.04378 | -0.34248 | 0.03568 |
| 7 | 4 | 0.27358 | 0.02664 | 0.02917 | -0.04365 | -0.34286 | 0.03672 |
| 8 | 4 | 0.27290 | 0.02582 | 0.02929 | -0.04454 | -0.34250 | 0.03690 |
| 9 | 4 | 0.27276 | 0.02529 | 0.02941 | -0.04515 | -0.34234 | 0.03714 |
| 10 | 4 | 0.27294 | 0.02504 | 0.02950 | -0.04544 | -0.34235 | 0.03730 |
| 3 | 5 | 0.26556 | 0.00794 | 0.03837 | -0.05538 | -0.32983 | 0.03695 |
| 4 | 5 | 0.26576 | 0.00900 | 0.02791 | -0.05102 | -0.33663 | 0.03716 |
| 5 | 5 | 0.26612 | 0.00967 | 0.02943 | -0.05205 | -0.33869 | 0.03343 |
| 6 | 5 | 0.26770 | 0.01245 | 0.03106 | -0.05045 | -0.34015 | 0.03413 |
| 7 | 5 | 0.26939 | 0.01419 | 0.03109 | -0.04905 | -0.34214 | 0.03493 |
| 8 | 5 | 0.27087 | 0.01483 | 0.03117 | -0.04866 | -0.34374 | 0.03499 |
| 9 | 5 | 0.27103 | 0.01446 | 0.03135 | -0.04906 | -0.34420 | 0.03527 |
| 10 | 5 | 0.27092 | 0.01382 | 0.03157 | -0.04962 | -0.34434 | 0.03549 |
| 3 | 6 | 0.26456 | 0.00186 | 0.04006 | -0.06022 | -0.33055 | 0.03695 |
| 4 | 6 | 0.26522 | 0.00415 | 0.02881 | -0.05398 | -0.33711 | 0.03703 |
| 5 | 6 | 0.26678 | 0.00643 | 0.03007 | -0.05349 | -0.33964 | 0.03317 |
| 6 | 6 | 0.26768 | 0.00840 | 0.03165 | -0.05254 | -0.34024 | 0.03377 |
| 7 | 6 | 0.26789 | 0.00923 | 0.03176 | -0.05194 | -0.34096 | 0.03456 |
| 8 | 6 | 0.26881 | 0.01018 | 0.03183 | -0.05125 | -0.34222 | 0.03457 |
| 9 | 6 | 0.26989 | 0.01109 | 0.03192 | -0.05059 | -0.34338 | 0.03475 |
| 10 | 6 | 0.27035 | 0.01145 | 0.03206 | -0.05037 | -0.34399 | 0.03488 |
| 3 | 7 | 0.26707 | 0.00065 | 0.04036 | -0.06155 | -0.33305 | 0.03720 |
| 4 | 7 | 0.26389 | 0.00165 | 0.02901 | -0.05642 | -0.33649 | 0.03714 |
| 5 | 7 | 0.26674 | 0.00534 | 0.03014 | -0.05435 | -0.33967 | 0.03313 |
| 6 | 7 | 0.26758 | 0.00773 | 0.03171 | -0.05286 | -0.34007 | 0.03365 |
| 7 | 7 | 0.26764 | 0.00821 | 0.03171 | -0.05248 | -0.34045 | 0.03435 |
| 8 | 7 | 0.26793 | 0.00851 | 0.03178 | -0.05231 | -0.34104 | 0.03433 |
| 9 | 7 | 0.26837 | 0.00901 | 0.03189 | -0.05194 | -0.34170 | 0.03451 |
| 10 | 7 | 0.26897 | 0.00961 | 0.03205 | -0.05146 | -0.34243 | 0.03465 |

Table 9 (continued)

| m_1 | n | \hat{Q}'_{21} | \hat{Q}'_{22} | \hat{Q}'_{23} | \hat{Q}''_{21} | \hat{Q}''_{22} | \hat{Q}''_{23} |
|-------|-----|-----------------|-----------------|-----------------|------------------|------------------|------------------|
| 3 | 8 | 0.26846 | -0.00069 | 0.04066 | -0.06341 | -0.33511 | 0.03766 |
| 4 | 8 | 0.26482 | 0.00072 | 0.02909 | -0.05757 | -0.33751 | 0.03731 |
| 5 | 8 | 0.26612 | 0.00376 | 0.03024 | -0.05587 | -0.33936 | 0.03325 |
| 6 | 8 | 0.26786 | 0.00711 | 0.03170 | -0.05344 | -0.34025 | 0.03368 |
| 7 | 8 | 0.26766 | 0.00784 | 0.03169 | -0.05278 | -0.34040 | 0.03435 |
| 8 | 8 | 0.26788 | 0.00819 | 0.03173 | -0.05256 | -0.34084 | 0.03428 |
| 9 | 8 | 0.26808 | 0.00846 | 0.03182 | -0.05238 | -0.34119 | 0.03443 |
| 10 | 8 | 0.26831 | 0.00874 | 0.03196 | -0.05217 | -0.34157 | 0.03454 |
| | | \hat{Q}'_{31} | \hat{Q}'_{32} | \hat{Q}'_{33} | \hat{Q}''_{31} | \hat{Q}''_{32} | \hat{Q}''_{33} |
| 3 | 3 | 0.07296 | 0.25114 | 0.13071 | 0.15408 | 0.03483 | -0.38930 |
| 4 | 3 | 0.07217 | 0.25766 | 0.14110 | 0.15751 | 0.03616 | -0.39407 |
| 5 | 3 | 0.06975 | 0.25876 | 0.14469 | 0.15834 | 0.03837 | -0.39349 |
| 6 | 3 | 0.06924 | 0.25786 | 0.14600 | 0.15775 | 0.03879 | -0.39439 |
| 7 | 3 | 0.06949 | 0.25762 | 0.14689 | 0.15751 | 0.03871 | -0.39474 |
| 8 | 3 | 0.06960 | 0.25756 | 0.14712 | 0.15745 | 0.03865 | -0.39454 |
| 9 | 3 | 0.06971 | 0.25740 | 0.14684 | 0.15732 | 0.03850 | -0.39428 |
| 10 | 3 | 0.06982 | 0.25721 | 0.14643 | 0.15714 | 0.03831 | -0.39398 |
| 3 | 4 | 0.07505 | 0.25517 | 0.12537 | 0.15510 | 0.03410 | -0.38627 |
| 4 | 4 | 0.07481 | 0.26071 | 0.13441 | 0.15741 | 0.03482 | -0.39084 |
| 5 | 4 | 0.07303 | 0.26184 | 0.13764 | 0.15791 | 0.03662 | -0.39020 |
| 6 | 4 | 0.07209 | 0.26285 | 0.13934 | 0.15858 | 0.03758 | -0.39141 |
| 7 | 4 | 0.07174 | 0.26373 | 0.14132 | 0.15911 | 0.03821 | -0.39248 |
| 8 | 4 | 0.07146 | 0.26418 | 0.14291 | 0.15945 | 0.03872 | -0.39304 |
| 9 | 4 | 0.07125 | 0.26443 | 0.14395 | 0.15966 | 0.03905 | -0.39345 |
| 10 | 4 | 0.07114 | 0.26464 | 0.14464 | 0.15982 | 0.03925 | -0.39373 |
| 3 | 5 | 0.07631 | 0.25468 | 0.12302 | 0.15410 | 0.03342 | -0.38505 |
| 4 | 5 | 0.07595 | 0.26087 | 0.13159 | 0.15695 | 0.03388 | -0.38955 |
| 5 | 5 | 0.07446 | 0.26166 | 0.13487 | 0.15717 | 0.03547 | -0.38893 |
| 6 | 5 | 0.07359 | 0.26211 | 0.13634 | 0.15747 | 0.03634 | -0.38996 |
| 7 | 5 | 0.07323 | 0.26312 | 0.13802 | 0.15810 | 0.03691 | -0.39085 |
| 8 | 5 | 0.07280 | 0.26402 | 0.13944 | 0.15874 | 0.03749 | -0.39134 |
| 9 | 5 | 0.07242 | 0.26448 | 0.14050 | 0.15909 | 0.03795 | -0.39180 |
| 10 | 5 | 0.07217 | 0.26480 | 0.14142 | 0.15935 | 0.03831 | -0.39222 |

Table 9 (concluded)

| m_1 | n | \hat{Q}'_{31} | \hat{Q}'_{32} | \hat{Q}'_{33} | \hat{Q}''_{31} | \hat{Q}''_{32} | \hat{Q}''_{33} |
|-------|-----|-----------------|-----------------|-----------------|------------------|------------------|------------------|
| 3 | 6 | 0.07654 | 0.25521 | 0.12308 | 0.15416 | 0.03365 | -0.38481 |
| 4 | 6 | 0.07610 | 0.26080 | 0.13123 | 0.15676 | 0.03393 | -0.38915 |
| 5 | 6 | 0.07461 | 0.26146 | 0.13410 | 0.15696 | 0.03532 | -0.38825 |
| 6 | 6 | 0.07395 | 0.26161 | 0.13533 | 0.15704 | 0.03598 | -0.38922 |
| 7 | 6 | 0.07372 | 0.26236 | 0.13685 | 0.15746 | 0.03642 | -0.39012 |
| 8 | 6 | 0.07337 | 0.26311 | 0.13811 | 0.15800 | 0.03691 | -0.39057 |
| 9 | 6 | 0.07302 | 0.26368 | 0.13899 | 0.15843 | 0.03730 | -0.39098 |
| 10 | 6 | 0.07276 | 0.26409 | 0.13972 | 0.15873 | 0.03761 | -0.39133 |
| 3 | 7 | 0.07655 | 0.25570 | 0.12340 | 0.15440 | 0.03409 | -0.38503 |
| 4 | 7 | 0.07611 | 0.26045 | 0.13111 | 0.15644 | 0.03421 | -0.38909 |
| 5 | 7 | 0.07480 | 0.26106 | 0.13358 | 0.15664 | 0.03526 | -0.38804 |
| 6 | 7 | 0.07417 | 0.26115 | 0.13453 | 0.15668 | 0.03579 | -0.38891 |
| 7 | 7 | 0.07404 | 0.26180 | 0.13591 | 0.15703 | 0.03611 | -0.38974 |
| 8 | 7 | 0.07374 | 0.26242 | 0.13711 | 0.15748 | 0.03654 | -0.39017 |
| 9 | 7 | 0.07341 | 0.26288 | 0.13799 | 0.15784 | 0.03691 | -0.39057 |
| 10 | 7 | 0.07316 | 0.26332 | 0.13874 | 0.15817 | 0.03720 | -0.39092 |
| 3 | 8 | 0.07625 | 0.25652 | 0.12467 | 0.15494 | 0.03489 | -0.38550 |
| 4 | 8 | 0.07591 | 0.26089 | 0.13168 | 0.15671 | 0.03465 | -0.38931 |
| 5 | 8 | 0.07474 | 0.26108 | 0.13380 | 0.15663 | 0.03551 | -0.38811 |
| 6 | 8 | 0.07413 | 0.26119 | 0.13461 | 0.15671 | 0.03591 | -0.38889 |
| 7 | 8 | 0.07400 | 0.26170 | 0.13587 | 0.15697 | 0.03616 | -0.38963 |
| 8 | 8 | 0.07376 | 0.26221 | 0.13697 | 0.15734 | 0.03651 | -0.38998 |
| 9 | 8 | 0.07349 | 0.26257 | 0.13774 | 0.15762 | 0.03681 | -0.39034 |
| 10 | 8 | 0.07328 | 0.26290 | 0.13840 | 0.15787 | 0.03706 | -0.39065 |

Table 10

NUMERICAL VALUES OF APPROXIMATIONS \hat{Q}_{ij} , $i=1(1)3$, $j=1(1)3$, TO THE
 GENERALISED AIRFORCE COEFFICIENTS FOR THE FIN-TAILPLANE CONFIGURATION OF
 EXAMPLE 4.5 WITH DIHEDRAL ANGLE $\alpha=0$, $M=0.8$ AND FREQUENCY PARAMETER $\nu=1.5$
 WITH $m_1 = m_1' = m_2 = m_2'$, $n = n_1' = n_2' = 3$, $a_1 = a_2 = a$
 AND A NUMBER OF COMBINATIONS OF VALUES OF m_1 AND a

| m_1 | a | \hat{Q}_{11}' | \hat{Q}_{12}' | \hat{Q}_{13}' | \hat{Q}_{11}'' | \hat{Q}_{12}'' | \hat{Q}_{13}'' |
|-------|-----|-----------------|-----------------|-----------------|------------------|------------------|------------------|
| 4 | 1 | 0.50112 | -0.96535 | 0.07411 | -0.75728 | -0.64034 | 0.09777 |
| 4 | 2 | 0.51299 | -0.94871 | 0.07984 | -0.75741 | -0.64286 | 0.09558 |
| 4 | 4 | 0.52690 | -0.95294 | 0.08353 | -0.76797 | -0.64853 | 0.09556 |
| 5 | 1 | 0.51094 | -0.96933 | 0.07575 | -0.76187 | -0.65037 | 0.08815 |
| 5 | 2 | 0.50611 | -0.95369 | 0.07938 | -0.75559 | -0.64359 | 0.08799 |
| 5 | 4 | 0.51015 | -0.95455 | 0.08177 | -0.76152 | -0.64458 | 0.08571 |
| 6 | 1 | 0.50814 | -0.96007 | 0.07987 | -0.75679 | -0.64806 | 0.08826 |
| 6 | 2 | 0.50801 | -0.95697 | 0.07849 | -0.75800 | -0.64648 | 0.08725 |
| 6 | 4 | 0.51249 | -0.95902 | 0.08070 | -0.76425 | -0.64824 | 0.08583 |
| 7 | 1 | 0.50462 | -0.95683 | 0.07968 | -0.75477 | -0.64596 | 0.08893 |
| 7 | 2 | 0.50962 | -0.95732 | 0.07922 | -0.75809 | -0.64788 | 0.08640 |
| 7 | 4 | 0.51463 | -0.95987 | 0.08194 | -0.76411 | -0.65011 | 0.08491 |
| 8 | 1 | 0.50421 | -0.95633 | 0.07891 | -0.75474 | -0.64586 | 0.08845 |
| 8 | 2 | 0.50925 | -0.95685 | 0.07897 | -0.75745 | -0.64782 | 0.08639 |
| 8 | 4 | 0.51432 | -0.95955 | 0.08141 | -0.76308 | -0.65020 | 0.08509 |

Table 10 (concluded)

| m_1 | a | \hat{Q}'_{21} | \hat{Q}'_{22} | \hat{Q}'_{23} | \hat{Q}''_{21} | \hat{Q}''_{22} | \hat{Q}''_{23} |
|-------|---|-----------------|-----------------|-----------------|------------------|------------------|------------------|
| 4 | 1 | 0.26005 | 0.07054 | 0.01216 | -0.02005 | -0.31285 | 0.03960 |
| 4 | 2 | 0.25878 | 0.06517 | 0.01476 | -0.02313 | -0.30817 | 0.03922 |
| 4 | 4 | 0.26317 | 0.06654 | 0.01409 | -0.02304 | -0.30981 | 0.03961 |
| 5 | 1 | 0.26445 | 0.07381 | 0.01622 | -0.01822 | -0.31545 | 0.03676 |
| 5 | 2 | 0.25835 | 0.06734 | 0.01719 | -0.02153 | -0.30994 | 0.03740 |
| 5 | 4 | 0.25936 | 0.06629 | 0.01780 | -0.02299 | -0.31001 | 0.03708 |
| 6 | 1 | 0.26147 | 0.07181 | 0.01752 | -0.01887 | -0.31258 | 0.03765 |
| 6 | 2 | 0.26051 | 0.06940 | 0.01682 | -0.02042 | -0.31132 | 0.03693 |
| 6 | 4 | 0.26191 | 0.06902 | 0.01701 | -0.02140 | -0.31173 | 0.03677 |
| 7 | 1 | 0.25968 | 0.06996 | 0.01722 | -0.01980 | -0.31116 | 0.03780 |
| 7 | 2 | 0.26114 | 0.07049 | 0.01747 | -0.01960 | -0.31161 | 0.03693 |
| 7 | 4 | 0.26274 | 0.07063 | 0.01800 | -0.02010 | -0.31221 | 0.03693 |
| 8 | 1 | 0.25958 | 0.06957 | 0.01717 | -0.02002 | -0.31094 | 0.03741 |
| 8 | 2 | 0.26101 | 0.07059 | 0.01737 | -0.01945 | -0.31150 | 0.03681 |
| 8 | 4 | 0.26264 | 0.07096 | 0.01781 | -0.01971 | -0.31219 | 0.03680 |

| m_1 | a | Q'_{31} | Q'_{32} | Q'_{33} | Q''_{31} | Q''_{32} | Q''_{33} |
|-------|---|-----------|-----------|-----------|------------|------------|------------|
| 4 | 1 | 0.07217 | 0.25766 | 0.14110 | 0.15751 | 0.03616 | -0.39407 |
| 4 | 2 | 0.06836 | 0.25727 | 0.14594 | 0.15945 | 0.03886 | -0.39518 |
| 4 | 4 | 0.06877 | 0.25779 | 0.14322 | 0.16077 | 0.03834 | -0.39408 |
| 5 | 1 | 0.06975 | 0.25876 | 0.14469 | 0.15834 | 0.03837 | -0.39349 |
| 5 | 2 | 0.06993 | 0.25711 | 0.14588 | 0.15789 | 0.03804 | -0.39399 |
| 5 | 4 | 0.07056 | 0.25733 | 0.14420 | 0.15887 | 0.03765 | -0.39298 |
| 6 | 1 | 0.06924 | 0.25786 | 0.14600 | 0.15775 | 0.03879 | -0.39439 |
| 6 | 2 | 0.07032 | 0.25717 | 0.14540 | 0.15767 | 0.03789 | -0.39336 |
| 6 | 4 | 0.07067 | 0.25772 | 0.14470 | 0.15891 | 0.03785 | -0.39278 |
| 7 | 1 | 0.06949 | 0.25762 | 0.14689 | 0.15751 | 0.03871 | -0.39474 |
| 7 | 2 | 0.07033 | 0.25700 | 0.14466 | 0.15741 | 0.03780 | -0.39292 |
| 7 | 4 | 0.07048 | 0.25769 | 0.14429 | 0.15871 | 0.03794 | -0.39252 |
| 8 | 1 | 0.06960 | 0.25756 | 0.14712 | 0.15745 | 0.03865 | -0.39454 |
| 8 | 2 | 0.07037 | 0.25688 | 0.14451 | 0.15721 | 0.03773 | -0.39280 |
| 8 | 4 | 0.07042 | 0.25758 | 0.14428 | 0.15846 | 0.03793 | -0.39245 |

Table 11

NUMERICAL VALUES OF APPROXIMATIONS \hat{Q}_{ij} , $i=1(1)3$, $j=1(1)3$, TO THE
 GENERALISED AIRFORCE COEFFICIENTS FOR THE FIN-TAILPLANE CONFIGURATION OF
 EXAMPLE 4.5 WITH DIHEDRAL ANGLE $\alpha=0$, $M=0.8$ AND FREQUENCY PARAMETER $\nu=1.5$
 WITH $m_1' = m_1$, $m_2' = m_2$, $n_1' = n_2' = n = 3$, $a_1 = a_2 = 1$
 AND A NUMBER OF COMBINATIONS OF VALUES OF m_1 AND m_2 .

| m_1 | m_2 | Q'_{11} | Q'_{12} | Q'_{13} | Q''_{11} | Q''_{12} | Q''_{13} |
|-------|-------|-----------|-----------|-----------|------------|------------|------------|
| 3 | 3 | 0.50135 | -0.94306 | 0.09438 | -0.76001 | -0.63726 | 0.08305 |
| 4 | 3 | 0.49352 | -0.92549 | 0.08665 | -0.73541 | -0.63214 | 0.07856 |
| 3 | 4 | 0.50104 | -0.97849 | 0.07379 | -0.78070 | -0.63851 | 0.10333 |
| 4 | 4 | 0.50112 | -0.96535 | 0.07411 | -0.75728 | -0.64034 | 0.09777 |
| 5 | 4 | 0.50078 | -0.96043 | 0.07910 | -0.75294 | -0.64272 | 0.09321 |
| 4 | 5 | 0.51247 | -0.97155 | 0.07594 | -0.76508 | -0.64812 | 0.08895 |
| 5 | 5 | 0.51094 | -0.96933 | 0.07575 | -0.76187 | -0.65037 | 0.08815 |
| 6 | 5 | 0.51004 | -0.96798 | 0.07587 | -0.76145 | -0.65098 | 0.08868 |
| 5 | 6 | 0.50640 | -0.95903 | 0.08055 | -0.75531 | -0.64532 | 0.08861 |
| 6 | 6 | 0.50814 | -0.96007 | 0.07987 | -0.75679 | -0.64806 | 0.08826 |

Table 11 (concluded)

| m_1 | m_2 | \hat{Q}'_{21} | \hat{Q}'_{22} | \hat{Q}'_{23} | \hat{Q}''_{21} | \hat{Q}''_{22} | \hat{Q}''_{23} |
|-------|-------|-----------------|-----------------|-----------------|------------------|------------------|------------------|
| 3 | 3 | 0.26061 | 0.07252 | 0.02281 | -0.02229 | -0.30714 | 0.04233 |
| 4 | 3 | 0.25042 | 0.07240 | 0.02108 | -0.01940 | -0.30157 | 0.03752 |
| 3 | 4 | 0.26769 | 0.06503 | 0.01050 | -0.02655 | -0.31623 | 0.04069 |
| 4 | 4 | 0.26005 | 0.07054 | 0.01216 | -0.02005 | -0.31285 | 0.03960 |
| 5 | 4 | 0.25864 | 0.07296 | 0.01492 | -0.01796 | -0.31134 | 0.03896 |
| 4 | 5 | 0.26594 | 0.07287 | 0.01623 | -0.01946 | -0.31669 | 0.03717 |
| 5 | 5 | 0.26445 | 0.07381 | 0.01622 | -0.01822 | -0.31545 | 0.03676 |
| 6 | 5 | 0.26366 | 0.07358 | 0.01601 | -0.01803 | -0.31433 | 0.03694 |
| 5 | 6 | 0.26081 | 0.07125 | 0.01779 | -0.01936 | -0.31272 | 0.03827 |
| 6 | 6 | 0.26147 | 0.07181 | 0.01752 | -0.01887 | -0.31258 | 0.03765 |

| m_1 | m_2 | \hat{Q}'_{31} | \hat{Q}'_{32} | \hat{Q}'_{33} | \hat{Q}''_{31} | \hat{Q}''_{32} | \hat{Q}''_{33} |
|-------|-------|-----------------|-----------------|-----------------|------------------|------------------|------------------|
| 3 | 3 | 0.07296 | 0.25114 | 0.13071 | 0.15408 | 0.03483 | -0.38930 |
| 4 | 3 | 0.07060 | 0.25001 | 0.13128 | 0.15209 | 0.03600 | -0.38729 |
| 3 | 4 | 0.07504 | 0.26043 | 0.14060 | 0.16180 | 0.03532 | -0.39513 |
| 4 | 4 | 0.07217 | 0.25766 | 0.14110 | 0.15751 | 0.03616 | -0.39407 |
| 5 | 4 | 0.07222 | 0.25660 | 0.14057 | 0.15597 | 0.03614 | -0.39300 |
| 4 | 5 | 0.06926 | 0.25916 | 0.14449 | 0.15956 | 0.03841 | -0.39376 |
| 5 | 5 | 0.06975 | 0.25876 | 0.14469 | 0.15834 | 0.03837 | -0.39349 |
| 6 | 5 | 0.07020 | 0.25869 | 0.14463 | 0.15799 | 0.03822 | -0.39355 |
| 5 | 6 | 0.06902 | 0.25747 | 0.14591 | 0.15776 | 0.03870 | -0.39457 |
| 6 | 6 | 0.06924 | 0.25786 | 0.14600 | 0.15775 | 0.03879 | -0.39439 |

Table 12
 NUMERICAL VALUES OF APPROXIMATIONS \hat{Q}_{ij} , $i = 1(1)6$, $j = 1(1)6$, TO THE
 GENERALISED AIRFORCE COEFFICIENTS FOR THE FIN-TAILPLANE CONFIGURATION
 OF EXAMPLE 4.6 FOR A NUMBER OF VALUES OF THE DIHEDRAL ANGLE α

$$\nu = 0.0000001, M = 0.8$$

$$m_1 = m'_1 = m_2 = m'_2 = 8, n = n'_1 = n'_2 = 5, a_1 = a_2 = 1$$

| | | | | | | |
|-------------------|------------------|------------------|------------------|------------------|------------------|------------------|
| α | \hat{Q}'_{11} | \hat{Q}'_{12} | \hat{Q}'_{13} | \hat{Q}'_{14} | \hat{Q}'_{15} | \hat{Q}'_{16} |
| $-\frac{\pi}{6}$ | 0.00000 | -0.45868 | 0.00000 | 0.00000 | -0.57162 | 0.00000 |
| $-\frac{\pi}{12}$ | 0.00000 | -0.43857 | 0.00000 | 0.00000 | -0.62847 | 0.00000 |
| 0 | 0.00000 | -0.42525 | 0.00000 | 0.00000 | -0.67562 | 0.00000 |
| $\frac{\pi}{12}$ | 0.00000 | -0.41572 | 0.00000 | 0.00000 | -0.71180 | 0.00000 |
| $\frac{\pi}{6}$ | 0.00000 | -0.40850 | 0.00000 | 0.00000 | -0.73638 | 0.00000 |
| α | \hat{Q}''_{11} | \hat{Q}''_{12} | \hat{Q}''_{13} | \hat{Q}''_{14} | \hat{Q}''_{15} | \hat{Q}''_{16} |
| $-\frac{\pi}{6}$ | -0.35896 | -0.49920 | 0.14325 | -0.57162 | -0.62004 | -0.31543 |
| $-\frac{\pi}{12}$ | -0.34682 | -0.47940 | 0.11680 | -0.62847 | -0.63538 | -0.32177 |
| 0 | -0.33881 | -0.46620 | 0.09852 | -0.67562 | -0.63668 | -0.32673 |
| $\frac{\pi}{12}$ | -0.33309 | -0.45720 | 0.08522 | -0.71180 | -0.62569 | -0.33050 |
| $\frac{\pi}{6}$ | -0.32875 | -0.45121 | 0.07515 | -0.73638 | -0.60659 | -0.33335 |
| α | \hat{Q}'_{21} | \hat{Q}'_{22} | \hat{Q}'_{23} | \hat{Q}'_{24} | \hat{Q}'_{25} | \hat{Q}'_{26} |
| $-\frac{\pi}{6}$ | 0.00000 | 0.09126 | 0.00000 | 0.00000 | 0.14999 | 0.00000 |
| $-\frac{\pi}{12}$ | 0.00000 | 0.09238 | 0.00000 | 0.00000 | 0.15674 | 0.00000 |
| 0 | 0.00000 | 0.09295 | 0.00000 | 0.00000 | 0.16323 | 0.00000 |
| $\frac{\pi}{12}$ | 0.00000 | 0.09320 | 0.00000 | 0.00000 | 0.16887 | 0.00000 |
| $\frac{\pi}{6}$ | 0.00000 | 0.09328 | 0.00000 | 0.00000 | 0.17320 | 0.00000 |
| α | \hat{Q}''_{21} | \hat{Q}''_{22} | \hat{Q}''_{23} | \hat{Q}''_{24} | \hat{Q}''_{25} | \hat{Q}''_{26} |
| $-\frac{\pi}{6}$ | 0.06703 | -0.25279 | 0.00039 | 0.14999 | -0.37416 | 0.09164 |
| $-\frac{\pi}{12}$ | 0.06839 | -0.24325 | -0.00105 | 0.15674 | -0.40921 | 0.09134 |
| 0 | 0.06918 | -0.23708 | -0.00194 | 0.16323 | -0.44049 | 0.09101 |
| $\frac{\pi}{12}$ | 0.06965 | -0.23270 | -0.00251 | 0.16887 | -0.46670 | 0.09069 |
| $\frac{\pi}{6}$ | 0.06992 | -0.22930 | -0.00288 | 0.17320 | -0.48659 | 0.09040 |

Table 12 (continued)

| | | | | | | |
|-------------------|------------------|------------------|------------------|------------------|------------------|------------------|
| α | \hat{Q}'_{31} | \hat{Q}'_{32} | \hat{Q}'_{33} | \hat{Q}'_{34} | \hat{Q}'_{35} | \hat{Q}'_{36} |
| $-\frac{\pi}{6}$ | 0.00000 | 0.22109 | 0.00000 | 0.00000 | 0.01452 | 0.00000 |
| $-\frac{\pi}{12}$ | 0.00000 | 0.18035 | 0.00000 | 0.00000 | 0.17977 | 0.00000 |
| 0 | 0.00000 | 0.15234 | 0.00000 | 0.00000 | 0.35679 | 0.00000 |
| $\frac{\pi}{12}$ | 0.00000 | 0.13194 | 0.00000 | 0.00000 | 0.52880 | 0.00000 |
| $\frac{\pi}{6}$ | 0.00000 | 0.11641 | 0.00000 | 0.00000 | 0.67914 | 0.00000 |
| α | \hat{Q}''_{31} | \hat{Q}''_{32} | \hat{Q}''_{33} | \hat{Q}''_{34} | \hat{Q}''_{35} | \hat{Q}''_{36} |
| $-\frac{\pi}{6}$ | 0.14062 | 0.13446 | -0.49151 | 0.01452 | -0.10211 | -0.27042 |
| $-\frac{\pi}{12}$ | 0.11458 | 0.09079 | -0.46922 | 0.17977 | 0.00499 | -0.28887 |
| 0 | 0.09660 | 0.05801 | -0.45353 | 0.35679 | 0.12109 | -0.30118 |
| $\frac{\pi}{12}$ | 0.08350 | 0.03255 | -0.44046 | 0.52880 | 0.23023 | -0.30852 |
| $\frac{\pi}{6}$ | 0.07352 | 0.01283 | -0.42747 | 0.67914 | 0.31883 | -0.31104 |
| α | \hat{Q}'_{41} | \hat{Q}'_{42} | \hat{Q}'_{43} | \hat{Q}'_{44} | \hat{Q}'_{45} | \hat{Q}'_{46} |
| $-\frac{\pi}{6}$ | 0.00000 | -0.78165 | 0.00000 | 0.00000 | -1.35846 | 0.00000 |
| $-\frac{\pi}{12}$ | 0.00000 | -0.86364 | 0.00000 | 0.00000 | -1.52206 | 0.00000 |
| 0 | 0.00000 | -0.93141 | 0.00000 | 0.00000 | -1.84038 | 0.00000 |
| $\frac{\pi}{12}$ | 0.00000 | -0.98322 | 0.00000 | 0.00000 | -2.30497 | 0.00000 |
| $\frac{\pi}{6}$ | 0.00000 | -1.01814 | 0.00000 | 0.00000 | -2.85162 | 0.00000 |
| α | \hat{Q}''_{41} | \hat{Q}''_{42} | \hat{Q}''_{43} | \hat{Q}''_{44} | \hat{Q}''_{45} | \hat{Q}''_{46} |
| $-\frac{\pi}{6}$ | -0.55877 | -0.91581 | 0.00688 | -1.35846 | -1.61322 | -0.77477 |
| $-\frac{\pi}{12}$ | -0.61185 | -0.95700 | 0.16720 | -1.52206 | -1.64208 | -0.69644 |
| 0 | -0.65563 | -0.97547 | 0.33980 | -1.84038 | -1.75802 | -0.59161 |
| $\frac{\pi}{12}$ | -0.68906 | -0.97295 | 0.50836 | -2.30497 | -1.96023 | -0.47486 |
| $\frac{\pi}{6}$ | -0.71165 | -0.95486 | 0.65652 | -2.85162 | -2.20678 | -0.36162 |

Table 12 (concluded)

| | | | | | | |
|-------------------|------------------|------------------|------------------|------------------|------------------|------------------|
| α | \hat{Q}'_{51} | \hat{Q}'_{52} | \hat{Q}'_{53} | \hat{Q}'_{54} | \hat{Q}'_{55} | \hat{Q}'_{56} |
| $-\frac{\pi}{6}$ | 0.00000 | 0.21598 | 0.00000 | 0.00000 | 0.49183 | 0.00000 |
| $-\frac{\pi}{12}$ | 0.00000 | 0.23417 | 0.00000 | 0.00000 | 0.55715 | 0.00000 |
| 0 | 0.00000 | 0.25019 | 0.00000 | 0.00000 | 0.66568 | 0.00000 |
| $\frac{\pi}{12}$ | 0.00000 | 0.26318 | 0.00000 | 0.00000 | 0.81292 | 0.00000 |
| $\frac{\pi}{6}$ | 0.00000 | 0.27253 | 0.00000 | 0.00000 | 0.97936 | 0.00000 |
| α | \hat{Q}''_{51} | \hat{Q}''_{52} | \hat{Q}''_{53} | \hat{Q}''_{54} | \hat{Q}''_{55} | \hat{Q}''_{56} |
| $-\frac{\pi}{6}$ | 0.12240 | -0.29094 | -0.02332 | 0.49183 | -0.51336 | 0.19266 |
| $-\frac{\pi}{12}$ | 0.13179 | -0.30895 | -0.04873 | 0.55715 | -0.56993 | 0.18544 |
| 0 | 0.14033 | -0.32758 | -0.07599 | 0.66568 | -0.67113 | 0.17420 |
| $\frac{\pi}{12}$ | 0.14751 | -0.34596 | -0.10254 | 0.81292 | -0.81806 | 0.16064 |
| $\frac{\pi}{6}$ | 0.15287 | -0.36247 | -0.12598 | 0.97936 | -0.99588 | 0.14655 |
| α | \hat{Q}'_{61} | \hat{Q}'_{62} | \hat{Q}'_{63} | \hat{Q}'_{64} | \hat{Q}'_{65} | \hat{Q}'_{66} |
| $-\frac{\pi}{6}$ | 0.00000 | -0.38755 | 0.00000 | 0.00000 | -0.77775 | 0.00000 |
| $-\frac{\pi}{12}$ | 0.00000 | -0.39536 | 0.00000 | 0.00000 | -0.69827 | 0.00000 |
| 0 | 0.00000 | -0.40163 | 0.00000 | 0.00000 | -0.59222 | 0.00000 |
| $\frac{\pi}{12}$ | 0.00000 | -0.40655 | 0.00000 | 0.00000 | -0.47446 | 0.00000 |
| $\frac{\pi}{6}$ | 0.00000 | -0.41039 | 0.00000 | 0.00000 | -0.36070 | 0.00000 |
| α | \hat{Q}''_{61} | \hat{Q}''_{62} | \hat{Q}''_{63} | \hat{Q}''_{64} | \hat{Q}''_{65} | \hat{Q}''_{66} |
| $-\frac{\pi}{6}$ | -0.31343 | -0.52326 | -0.27174 | -0.77775 | -0.96164 | -0.65929 |
| $-\frac{\pi}{12}$ | -0.31980 | -0.53370 | -0.29033 | -0.69827 | -0.88467 | -0.68569 |
| 0 | -0.32478 | -0.54436 | -0.30272 | -0.59222 | -0.77731 | -0.70434 |
| $\frac{\pi}{12}$ | -0.32863 | -0.55468 | -0.31001 | -0.47446 | -0.65760 | -0.71656 |
| $\frac{\pi}{6}$ | -0.33161 | -0.56416 | -0.31238 | -0.36070 | -0.54486 | -0.72277 |

Table 13

NUMERICAL VALUES OF APPROXIMATIONS \hat{Q}_{ij} , $i = 1(1)6$, $j = 1(1)6$ TO THE
 GENERALISED AIRFORCE COEFFICIENTS FOR THE FIN-TAILPLANE CONFIGURATION
 OF EXAMPLE 4.6 FOR A NUMBER OF VALUES OF THE DIHEDRAL ANGLE α

$$\nu = 1.5, M = 0.8$$

$$m_1 = m'_1 = m_2 = m'_2 = 8, n = n'_1 = n'_2 = 5, a_1 = a_2 = 1$$

| | | | | | | |
|-------------------|------------------|------------------|------------------|------------------|------------------|------------------|
| α | \hat{Q}'_{11} | \hat{Q}'_{12} | \hat{Q}'_{13} | \hat{Q}'_{14} | \hat{Q}'_{15} | \hat{Q}'_{16} |
| $-\frac{\pi}{6}$ | 0.32546 | -0.83758 | 0.04089 | 0.59699 | -1.14696 | 0.44292 |
| $-\frac{\pi}{12}$ | 0.32391 | -0.71875 | 0.08462 | 0.56154 | -1.19952 | 0.46935 |
| 0 | 0.34326 | -0.63059 | 0.10038 | 0.53642 | -1.22822 | 0.50125 |
| $\frac{\pi}{12}$ | 0.36692 | -0.57217 | 0.10360 | 0.51812 | -1.23802 | 0.53036 |
| $\frac{\pi}{6}$ | 0.38829 | -0.53530 | 0.10177 | 0.50419 | -1.22960 | 0.55398 |
| α | \hat{Q}''_{11} | \hat{Q}''_{12} | \hat{Q}''_{13} | \hat{Q}''_{14} | \hat{Q}''_{15} | \hat{Q}''_{16} |
| $-\frac{\pi}{6}$ | -0.51946 | -0.45316 | 0.27691 | -0.90120 | -0.53191 | -0.42458 |
| $-\frac{\pi}{12}$ | -0.46317 | -0.41640 | 0.20866 | -0.94951 | -0.50979 | -0.41002 |
| 0 | -0.42660 | -0.41161 | 0.15629 | -0.97838 | -0.49524 | -0.40625 |
| $\frac{\pi}{12}$ | -0.40516 | -0.41979 | 0.11728 | -0.99148 | -0.48429 | -0.41031 |
| $\frac{\pi}{6}$ | -0.39342 | -0.43152 | 0.08774 | -0.99018 | -0.47450 | -0.41895 |
| α | \hat{Q}'_{21} | \hat{Q}'_{22} | \hat{Q}'_{23} | \hat{Q}'_{24} | \hat{Q}'_{25} | \hat{Q}'_{26} |
| $-\frac{\pi}{6}$ | 0.26771 | -0.03886 | -0.17634 | 0.59285 | -0.06999 | 0.23064 |
| $-\frac{\pi}{12}$ | 0.22330 | -0.02954 | -0.11733 | 0.60691 | -0.10712 | 0.22041 |
| 0 | 0.20035 | -0.00375 | -0.07635 | 0.61295 | -0.12857 | 0.22225 |
| $\frac{\pi}{12}$ | 0.19079 | 0.02310 | -0.04828 | 0.61259 | -0.14020 | 0.23080 |
| $\frac{\pi}{6}$ | 0.18830 | 0.04578 | -0.02825 | 0.60532 | -0.14499 | 0.24233 |
| α | \hat{Q}''_{21} | \hat{Q}''_{22} | \hat{Q}''_{23} | \hat{Q}''_{24} | \hat{Q}''_{25} | \hat{Q}''_{26} |
| $-\frac{\pi}{6}$ | -0.06503 | -0.38181 | 0.09616 | -0.04762 | -0.56312 | 0.01232 |
| $-\frac{\pi}{12}$ | 0.04800 | -0.32667 | 0.09153 | -0.07039 | -0.57628 | 0.02602 |
| 0 | -0.02914 | -0.29240 | 0.08126 | -0.08327 | -0.58302 | 0.03873 |
| $\frac{\pi}{12}$ | -0.01338 | -0.27320 | 0.07053 | -0.08953 | -0.58394 | 0.04823 |
| $\frac{\pi}{6}$ | -0.00152 | -0.26314 | 0.06096 | -0.09108 | -0.57841 | 0.05445 |

Table 13 (continued)

| | | | | | | |
|-------------------|------------------|------------------|------------------|------------------|------------------|------------------|
| α | \hat{Q}'_{31} | \hat{Q}'_{32} | \hat{Q}'_{33} | \hat{Q}'_{34} | \hat{Q}'_{35} | \hat{Q}'_{36} |
| $-\frac{\pi}{6}$ | 0.11496 | 0.63090 | 0.31796 | 0.32352 | 0.60037 | 0.40899 |
| $-\frac{\pi}{12}$ | 0.14761 | 0.48844 | 0.29595 | 0.27428 | 0.77605 | 0.44966 |
| 0 | 0.15171 | 0.37186 | 0.30134 | 0.17231 | 0.91867 | 0.47413 |
| $\frac{\pi}{12}$ | 0.14438 | 0.28264 | 0.31448 | 0.03774 | 1.02226 | 0.48738 |
| $\frac{\pi}{6}$ | 0.13353 | 0.21469 | 0.32092 | -0.09667 | 1.08322 | 0.48698 |
| α | \hat{Q}''_{31} | \hat{Q}''_{32} | \hat{Q}''_{33} | \hat{Q}''_{34} | \hat{Q}''_{35} | \hat{Q}''_{36} |
| $-\frac{\pi}{6}$ | 0.27441 | 0.06210 | -0.65477 | 0.26041 | -0.23079 | -0.22535 |
| $-\frac{\pi}{12}$ | 0.19774 | -0.01427 | -0.58811 | 0.42232 | -0.18167 | -0.26942 |
| 0 | 0.14052 | -0.05100 | -0.53495 | 0.57315 | -0.09383 | -0.29989 |
| $\frac{\pi}{12}$ | 0.09895 | -0.06774 | -0.49233 | 0.70308 | 0.01553 | -0.31870 |
| $\frac{\pi}{6}$ | 0.06822 | -0.07512 | -0.45565 | 0.80163 | 0.12082 | -0.32774 |
| α | \hat{Q}'_{41} | \hat{Q}'_{42} | \hat{Q}'_{43} | \hat{Q}'_{44} | \hat{Q}'_{45} | \hat{Q}'_{46} |
| $-\frac{\pi}{6}$ | 0.35794 | -1.53891 | 0.38268 | 1.75441 | -2.83320 | 0.99752 |
| $-\frac{\pi}{12}$ | 0.30178 | -1.60388 | 0.34470 | 1.54165 | -3.36327 | 0.88813 |
| 0 | 0.26854 | -1.62865 | 0.24299 | 1.43104 | -4.06167 | 0.74184 |
| $\frac{\pi}{12}$ | 0.25092 | -1.62569 | 0.10194 | 1.48087 | -4.84136 | 0.57386 |
| $\frac{\pi}{6}$ | 0.24481 | -1.59898 | -0.04249 | 1.67169 | -5.57360 | 0.41480 |
| α | \hat{Q}''_{41} | \hat{Q}''_{42} | \hat{Q}''_{43} | \hat{Q}''_{44} | \hat{Q}''_{45} | \hat{Q}''_{46} |
| $-\frac{\pi}{6}$ | -0.86290 | -0.72850 | 0.24352 | -2.08810 | -1.32231 | -1.02289 |
| $-\frac{\pi}{12}$ | -0.88306 | -0.68960 | 0.38948 | -2.38885 | -1.15931 | -0.92358 |
| 0 | -0.88898 | -0.66480 | 0.52919 | -2.82760 | -1.07360 | -0.80552 |
| $\frac{\pi}{12}$ | -0.88450 | -0.64856 | 0.65281 | -3.36377 | -1.10323 | -0.68438 |
| $\frac{\pi}{6}$ | -0.87048 | -0.63685 | 0.74746 | -3.91127 | -1.23024 | -0.57489 |

Table 13 (concluded)

| | | | | | | |
|-------------------|------------------|------------------|------------------|------------------|------------------|------------------|
| α | \hat{Q}'_{51} | \hat{Q}'_{52} | \hat{Q}'_{53} | \hat{Q}'_{54} | \hat{Q}'_{55} | \hat{Q}'_{56} |
| $-\frac{\pi}{6}$ | 0.41816 | 0.12069 | -0.19452 | 0.71852 | 0.49189 | 0.37990 |
| $-\frac{\pi}{12}$ | 0.39677 | 0.08784 | -0.19113 | 0.81780 | 0.43594 | 0.35661 |
| 0 | 0.37942 | 0.07546 | -0.18750 | 0.92284 | 0.42233 | 0.33776 |
| $\frac{\pi}{12}$ | 0.36610 | 0.07334 | -0.18474 | 1.02114 | 0.46097 | 0.32287 |
| $\frac{\pi}{6}$ | 0.35470 | 0.07566 | -0.18029 | 1.09820 | 0.53869 | 0.31181 |
| α | \hat{Q}''_{51} | \hat{Q}''_{52} | \hat{Q}''_{53} | \hat{Q}''_{54} | \hat{Q}''_{55} | \hat{Q}''_{56} |
| $-\frac{\pi}{6}$ | -0.04390 | -0.51033 | 0.07701 | 0.29531 | -0.86239 | 0.09054 |
| $-\frac{\pi}{12}$ | -0.05327 | -0.49783 | 0.08161 | 0.27727 | -0.96303 | 0.08465 |
| 0 | -0.05416 | -0.48346 | 0.07083 | 0.28990 | -1.09178 | 0.07431 |
| $\frac{\pi}{12}$ | -0.05132 | -0.47004 | 0.05127 | 0.33841 | -1.23569 | 0.05941 |
| $\frac{\pi}{6}$ | -0.04693 | -0.45706 | 0.02999 | 0.41248 | -1.37258 | 0.04382 |
| α | \hat{Q}'_{61} | \hat{Q}'_{62} | \hat{Q}'_{63} | \hat{Q}'_{64} | \hat{Q}'_{65} | \hat{Q}'_{66} |
| $-\frac{\pi}{6}$ | 0.43717 | -0.56506 | 0.37074 | 1.14114 | -1.14331 | 0.91932 |
| $-\frac{\pi}{12}$ | 0.46925 | -0.52003 | 0.41248 | 1.04943 | -1.04584 | 0.99765 |
| 0 | 0.50305 | -0.50022 | 0.43984 | 0.92010 | -0.94626 | 1.06776 |
| $\frac{\pi}{12}$ | 0.53100 | -0.49960 | 0.45718 | 0.76638 | -0.85780 | 1.12282 |
| $\frac{\pi}{6}$ | 0.55172 | -0.51055 | 0.46124 | 0.61644 | -0.78489 | 1.15681 |
| α | \hat{Q}''_{61} | \hat{Q}''_{62} | \hat{Q}''_{63} | \hat{Q}''_{64} | \hat{Q}''_{65} | \hat{Q}''_{66} |
| $-\frac{\pi}{6}$ | -0.41655 | -0.49808 | -0.22933 | -1.03423 | -0.92200 | -0.77376 |
| $-\frac{\pi}{12}$ | -0.40514 | -0.51805 | -0.26930 | -0.94413 | -0.84419 | -0.79379 |
| 0 | -0.40583 | -0.54688 | -0.29598 | -0.83671 | -0.73922 | -0.81676 |
| $\frac{\pi}{12}$ | -0.41419 | -0.57488 | -0.31178 | -0.72717 | -0.61737 | -0.83962 |
| $\frac{\pi}{6}$ | -0.42635 | -0.59875 | -0.31878 | -0.62775 | -0.50014 | -0.85943 |

Table 14

NUMERICAL VALUES OF APPROXIMATIONS \hat{Q}_{ij} , $i = 1(1)6$, $j = 1(1)6$, TO THE
 GENERALISED AIRFORCE COEFFICIENTS FOR THE FIN-TAILPLANE CONFIGURATION
 OF EXAMPLE 4.6 WITH DIHEDRAL ANGLE $\alpha = 0$ AND $M = 0.8$ FOR A NUMBER
 OF VALUES OF FREQUENCY PARAMETER ν

$$m_1 = m'_1 = m_2 = m'_2 = 8, \quad n = n'_1 = n'_2 = 5, \quad a_1 = a_2 = 1$$

| ν | \hat{Q}'_{11} | \hat{Q}'_{12} | \hat{Q}'_{13} | \hat{Q}'_{14} | \hat{Q}'_{15} | \hat{Q}'_{16} |
|---------------------|------------------------|------------------------|----------------------|------------------|------------------|------------------|
| 0.000001 (0.001) | 0.00000 (0.0) | -0.42525 (-0.41789) | 0.00000 (0.0) | 0.00000 | -0.67562 | 0.00000 |
| 0.25 | 0.01190 | -0.42674 | 0.00075 | 0.01954 | -0.68002 | 0.01492 |
| 0.50 | 0.04883 | -0.43624 | 0.00211 | 0.08272 | -0.70431 | 0.06075 |
| 0.75 (0.75) | 0.11067 (0.10684) | -0.46080 (-0.44158) | 0.00396 (0.00356) | 0.19283 | -0.76495 | 0.13791 |
| 1.00 | 0.19087 | -0.50962 | 0.01093 | 0.33832 | -0.88517 | 0.24299 |
| 1.25 (1.25) | 0.27156 (0.27518) | -0.58034 (-0.52460) | 0.03782 (0.02494) | 0.47176 | -1.06817 | 0.36555 |
| 1.50 (1.50) | 0.34326 (0.36366) | -0.63059 (-0.56912) | 0.10038 (0.06628) | 0.53642 | -1.22822 | 0.50125 |
| ν | \hat{Q}''_{11} | \hat{Q}''_{12} | \hat{Q}''_{13} | \hat{Q}''_{14} | \hat{Q}''_{15} | \hat{Q}''_{16} |
| 0.000001 (0.01) | -0.33881 (-0.33401) | -0.46620 (-0.45686) | 0.09852 (0.09716) | -0.67562 | -0.63668 | -0.32673 |
| 0.25 | -0.33956 | -0.47525 | 0.09850 | -0.67634 | -0.65555 | -0.32757 |
| 0.50 | -0.34556 | -0.48451 | 0.10101 | -0.68953 | -0.67533 | -0.33296 |
| 0.75 (0.75) | -0.36025 (-0.34613) | -0.49204 (-0.47924) | 0.10895 (0.10371) | -0.72654 | -0.69132 | -0.34526 |
| 1.00 | -0.38541 | -0.48959 | 0.12466 | -0.79783 | -0.68564 | -0.36580 |
| 1.25 (1.25) | -0.41439 (-0.38834) | -0.46230 (-0.46244) | 0.14537 (0.13087) | -0.89801 | -0.62287 | -0.39051 |
| 1.50 (1.50) | -0.42660 (-0.40475) | -0.41161 (-0.43067) | 0.15629 (0.14351) | -0.97838 | -0.49524 | -0.40625 |

Table 14 (continued)

| ν | \hat{Q}'_{21} | \hat{Q}'_{22} | \hat{Q}'_{23} | \hat{Q}'_{24} | \hat{Q}'_{25} | \hat{Q}'_{26} |
|---------------------|------------------------|------------------------|------------------------|------------------|------------------|------------------|
| 0.0000001 (0.01) | 0.00000 (0.0) | 0.09295 (0.08704) | 0.00000 (0.0) | 0.00000 | 0.16323 | 0.00000 |
| 0.25 | 0.00642 | 0.09567 | -0.00264 | -0.01576 | 0.16719 | 0.00613 |
| 0.50 | 0.02625 | 0.10331 | -0.01080 | 0.06485 | 0.17834 | 0.02515 |
| 0.75 (0.75) | 0.06150 (0.05558) | 0.11074 (0.10203) | -0.02575 (-0.02223) | 0.15487 | 0.18655 | 0.05910 |
| 1.00 | 0.11286 | 0.10454 | -0.04862 | 0.29553 | 0.16314 | 0.10947 |
| 1.25 (1.25) | 0.16885 (0.15086) | 0.06410 (0.07704) | -0.07300 (-0.06101) | 0.47267 | 0.05834 | 0.16982 |
| 1.50 (1.50) | 0.20035 (0.19129) | -0.00375 (0.03562) | -0.07635 (-0.07070) | 0.61295 | -0.12857 | 0.22225 |
| ν | \hat{Q}''_{21} | \hat{Q}''_{22} | \hat{Q}''_{23} | \hat{Q}''_{24} | \hat{Q}''_{25} | \hat{Q}''_{26} |
| 0.0000001 (0.01) | 0.06918 (0.06473) | -0.23708 (-0.22749) | -0.00194 (-0.00061) | 0.16323 | -0.44049 | 0.09101 |
| 0.25 | 0.06804 | -0.23910 | -0.00083 | 0.16133 | -0.44465 | 0.09077 |
| 0.50 | 0.06469 | -0.24986 | 0.00232 | 0.15645 | -0.46720 | 0.09007 |
| 0.75 (0.75) | 0.05678 (0.05295) | -0.26934 (-0.25070) | 0.00877 (0.00907) | 0.14354 | -0.50949 | 0.08711 |
| 1.00 | 0.03889 | -0.29429 | 0.02236 | 0.10785 | -0.56695 | 0.07797 |
| 1.25 (1.25) | 0.00631 (0.01546) | -0.30972 (-0.27771) | 0.04815 (0.03779) | 0.02833 | -0.60973 | 0.05929 |
| 1.50 (1.50) | -0.02914 (-0.01157) | -0.29240 (-0.27051) | 0.08126 (0.06198) | -0.08327 | -0.58302 | 0.03873 |

Table 14 (continued)

| ν | \hat{Q}'_{31} | \hat{Q}'_{32} | \hat{Q}'_{33} | \hat{Q}'_{34} | \hat{Q}'_{35} | \hat{Q}'_{36} |
|----------------------|----------------------|------------------------|------------------------|------------------|------------------|------------------|
| 0.0000001 (0.001) | 0.00000 (0.0) | 0.15234 (0.15080) | 0.00000 (0.0) | 0.00000 | 0.35679 | 0.00000 |
| 0.25 | 0.00096 | 0.15587 | 0.00967 | -0.00146 | 0.36495 | 0.01032 |
| 0.50 | 0.00334 | 0.16985 | 0.03957 | -0.00851 | 0.39704 | 0.04123 |
| 0.75 (0.75) | 0.00848 (0.00697) | 0.19981 (0.18743) | 0.09031 (0.09015) | -0.02179 | 0.46629 | 0.09439 |
| 1.00 | 0.02409 | 0.25274 | 0.15858 | -0.02771 | 0.59118 | 0.17603 |
| 1.25 (1.25) | 0.06842 (0.04641) | 0.32394 (0.28098) | 0.23258 (0.24305) | 0.01987 | 0.76972 | 0.29969 |
| 1.50 (1.50) | 0.15171 (0.10339) | 0.37186 (0.32998) | 0.30134 (0.32891) | 0.17231 | 0.91867 | 0.47413 |
| ν | \hat{Q}''_{31} | \hat{Q}''_{32} | \hat{Q}''_{33} | \hat{Q}''_{34} | \hat{Q}''_{35} | \hat{Q}''_{36} |
| 0.0000001 (0.001) | 0.09660 (0.09503) | 0.05801 (0.05964) | -0.45353 (-0.44871) | 0.35679 | 0.12109 | -0.30118 |
| 0.25 | 0.09708 | 0.06236 | -0.45443 | 0.35786 | 0.13105 | -0.30142 |
| 0.50 | 0.10095 | 0.06512 | -0.45904 | 0.36840 | 0.13973 | -0.30048 |
| 0.75 (0.75) | 0.11077 (0.10453) | 0.06373 (0.06587) | -0.47007 (-0.45986) | 0.39735 | 0.14150 | -0.29703 |
| 1.00 | 0.12747 | 0.05028 | -0.48980 | 0.45270 | 0.11959 | -0.29090 |
| 1.25 (1.25) | 0.14395 (0.13001) | 0.01132 (0.03376) | -0.51576 (-0.49479) | 0.52690 | 0.04251 | -0.28729 |
| 1.50 (1.50) | 0.14052 (0.13439) | -0.05100 (-0.00636) | -0.53495 (-0.51492) | 0.57315 | -0.09383 | -0.29989 |

Table 14 (continued)

| | | | | | | |
|-----------|------------------|------------------|------------------|------------------|------------------|------------------|
| v | \hat{Q}'_{41} | \hat{Q}'_{42} | \hat{Q}'_{43} | \hat{Q}'_{44} | \hat{Q}'_{45} | \hat{Q}'_{46} |
| 0.0000001 | 0.00000 | -0.93141 | 0.00000 | 0.00000 | -1.84038 | 0.00000 |
| 0.25 | 0.01866 | -0.94101 | -0.00122 | 0.06241 | -1.87308 | 0.02716 |
| 0.50 | 0.07651 | -0.98449 | -0.00664 | 0.25977 | -2.00408 | 0.11046 |
| 0.75 | 0.16816 | -1.08388 | -0.01423 | 0.59301 | -2.28669 | 0.24735 |
| 1.00 | 0.26491 | -1.26360 | -0.00586 | 1.00889 | -2.78909 | 0.42002 |
| 1.25 | 0.30425 | -1.49769 | 0.06737 | 1.33966 | -3.48789 | 0.58836 |
| 1.50 | 0.26854 | -1.62865 | 0.24299 | 1.43104 | -4.06167 | 0.74184 |
| v | \hat{Q}''_{41} | \hat{Q}''_{42} | \hat{Q}''_{43} | \hat{Q}''_{44} | \hat{Q}''_{45} | \hat{Q}''_{46} |
| 0.0000001 | -0.65563 | -0.97547 | 0.33980 | -1.84038 | -1.75802 | -0.59161 |
| 0.25 | -0.65981 | -0.99821 | 0.34191 | -1.85015 | -1.80715 | -0.59519 |
| 0.50 | -0.68222 | -1.01746 | 0.35500 | -1.90924 | -1.85396 | -0.61366 |
| 0.75 | -0.73160 | -1.02354 | 0.38677 | -2.04969 | -1.87685 | -0.65335 |
| 1.00 | -0.80920 | -0.98589 | 0.44219 | -2.29742 | -1.80890 | -0.71574 |
| 1.25 | -0.88508 | -0.85867 | 0.50681 | -2.61504 | -1.53716 | -0.78172 |
| 1.50 | -0.88898 | -0.66480 | 0.52919 | -2.82760 | -1.07360 | -0.80552 |
| v | \hat{Q}'_{51} | \hat{Q}'_{52} | \hat{Q}'_{53} | \hat{Q}'_{54} | \hat{Q}'_{55} | \hat{Q}'_{56} |
| 0.0000001 | 0.00000 | 0.25019 | 0.00000 | 0.00000 | 0.66568 | 0.00000 |
| 0.25 | 0.01109 | 0.25646 | -0.00519 | 0.01968 | 0.68232 | 0.00859 |
| 0.50 | 0.04546 | 0.27602 | -0.02121 | 0.08170 | 0.73503 | 0.03553 |
| 0.75 | 0.10852 | 0.29984 | -0.05137 | 0.20357 | 0.80795 | 0.08582 |
| 1.00 | 0.20540 | 0.30018 | -0.10087 | 0.41441 | 0.84477 | 0.16484 |
| 1.25 | 0.31733 | 0.22654 | -0.16157 | 0.70318 | 0.72956 | 0.26234 |
| 1.50 | 0.37942 | 0.07546 | -0.18750 | 0.92284 | 0.42233 | 0.33776 |
| v | \hat{Q}''_{51} | \hat{Q}''_{52} | \hat{Q}''_{53} | \hat{Q}''_{54} | \hat{Q}''_{55} | \hat{Q}''_{56} |
| 0.0000001 | 0.14033 | -0.32758 | -0.07599 | 0.66568 | -0.67113 | 0.17420 |
| 0.25 | 0.13840 | -0.32880 | -0.07426 | 0.66426 | -0.67383 | 0.17399 |
| 0.50 | 0.13392 | -0.35026 | -0.07028 | 0.66564 | -0.71951 | 0.17440 |
| 0.75 | 0.12242 | -0.39289 | -0.06209 | 0.66220 | -0.81380 | 0.17193 |
| 1.00 | 0.09148 | -0.45304 | -0.04161 | 0.62358 | -0.95514 | 0.15763 |
| 1.25 | 0.02648 | -0.50190 | 0.00443 | 0.49743 | -1.08983 | 0.12118 |
| 1.50 | -0.05416 | -0.48346 | 0.07083 | 0.28990 | -1.09178 | 0.07431 |

Table 14 (concluded)

| ν | \hat{Q}'_{61} | \hat{Q}'_{62} | \hat{Q}'_{63} | \hat{Q}'_{64} | \hat{Q}'_{65} | \hat{Q}'_{66} |
|-----------|------------------|------------------|------------------|------------------|------------------|------------------|
| 0.0000001 | 0.00000 | -0.40163 | 0.00000 | 0.00000 | -0.59222 | 0.00000 |
| 0.25 | 0.01496 | -0.40122 | 0.01018 | 0.02773 | -0.59404 | 0.02893 |
| 0.50 | 0.06082 | -0.40389 | 0.04047 | 0.11422 | -0.60803 | 0.11697 |
| 0.75 | 0.13783 | -0.41466 | 0.09172 | 0.26210 | -0.64587 | 0.26574 |
| 1.00 | 0.24242 | -0.43963 | 0.16822 | 0.46478 | -0.72323 | 0.47510 |
| 1.25 | 0.36486 | -0.47689 | 0.28073 | 0.69401 | -0.84143 | 0.74157 |
| 1.50 | 0.50305 | -0.50022 | 0.43984 | 0.92010 | -0.94626 | 1.06776 |
| ν | \hat{Q}''_{61} | \hat{Q}''_{62} | \hat{Q}''_{63} | \hat{Q}''_{64} | \hat{Q}''_{65} | \hat{Q}''_{66} |
| 0.0000001 | -0.32478 | -0.54436 | -0.30272 | -0.59222 | -0.77731 | -0.70434 |
| 0.25 | -0.32580 | -0.55242 | -0.30323 | -0.59366 | -0.79355 | -0.70604 |
| 0.50 | -0.33162 | -0.56175 | -0.30313 | -0.60611 | -0.81174 | -0.71349 |
| 0.75 | -0.34447 | -0.57137 | -0.30103 | -0.63691 | -0.82932 | -0.72872 |
| 1.00 | -0.36536 | -0.57597 | -0.29613 | -0.69260 | -0.83437 | -0.75313 |
| 1.25 | -0.38987 | -0.56678 | -0.29109 | -0.76921 | -0.80483 | -0.78474 |
| 1.50 | -0.40583 | -0.54688 | -0.29598 | -0.83671 | -0.73922 | -0.81676 |

LIST OF SYMBOLS

| | |
|---|--|
| a | speed of sound in the undisturbed main stream. Also a positive integer used in the relation (3-5) |
| a_1, a_2 | integers used in the relations (3-15) and (3-36) respectively |
| $a_r, a_r^{(a)}, a_r^{(1a)}$ | coefficients appearing in formulae (D-17), (D-26) and (D-28) respectively |
| A | a positive number used as a demarcation point in $(0, \infty)$ |
| $A(\xi, \sigma; \mu, M)$ | quantity defined by formula (B-27) |
| $A_r(1), A_r(A)$ | coefficients appearing in formulae (C-53) and (F-6) respectively |
| $[\bar{A}_p], [A_q]$ | matrices defined by formulae (2-105) and (2-106) respectively |
| $A_r(p, q)$ | quantity defined by formula (A-9) |
| $A_{q;r,s}^{(1)}, A_{q;r,s}^{(2)}$ | coefficients appearing in formulae (2-56) and (2-57) respectively |
| $\bar{A}_{p;i,j}^{(1)}, \bar{A}_{p;i,j}^{(2)}$ | coefficients appearing in formulae (2-79) and (2-80) respectively |
| $[A_q^{(0)}], [A_q^{(1)}], [A_q^{(2)}]$ | column matrices appearing in formula (2-106) and defined immediately afterwards |
| $[\bar{A}_p^{(0)}], [\bar{A}_p^{(1)}], [\bar{A}_p^{(2)}]$ | row matrices appearing in formula (2-105) and defined immediately afterwards |
| $b_r, b_r^{(a)}, b_r^{(1a)}$ | coefficients appearing in formulae (D-18), (D-27) and (D-29) respectively |
| $b_q(t)$ | generalised coordinate for mode number q (see formulae (2-1) to (2-3)) |
| \bar{b}_q | quantity defining amount of harmonic constituent in $b_q(t)$ (see formula (2-4)) |
| \bar{b}_q^* | complex conjugate of \bar{b}_q |
| $B(\xi, \sigma; \mu, M)$ | quantity defined by formula (B-28) |
| $B_r(1), B_r(A)$ | coefficients appearing in formulae (C-54) and (F-7) respectively |
| $B_r(p, q)$ | quantity defined by formula (A-10) |
| $c_r, c_r^{(a)}$ | coefficients appearing in formulae (D-19) and (D-71) |
| $c_1(z)$ | chord length of fin S_1 at spanwise position z (see Fig 1) |
| $c_2(u), c_3(u)$ | chord lengths respectively of half-tailplanes S_2 and S_3 at spanwise position u (see Fig 1) |
| $c_1'(z), c_1''(z)$ | first and second derivatives respectively of $c_1(z)$ |
| $C_r(A)$ | coefficients appearing in formulae (F-8) and (F-9) |

LIST OF SYMBOLS (continued)

| | |
|------------------------------------|---|
| $C_r(p,q)$ | quantity defined by formula (A-11) |
| $d_r, d_r^{(a)}$ | coefficients appearing in formulae (D-20) and (D-55) respectively |
| $D_r(A)$ | coefficients appearing in formula (F-8) |
| $D_r(p,q)$ | quantity defined by formula (A-20) |
| $D_r^{(n)}(\xi, \sigma; \mu, M)$ | quantity appearing in formula (B-19) |
| $[D]$ | matrix defined by formula (2-165) |
| $[D_1], [D_2]$ | diagonal matrices with respectively (2-159) and (2-161) as general diagonal element |
| $[D_{10}], [D_{20}]$ | diagonal matrices with respectively (2-158) and (2-160) as general diagonal element |
| $e_r, e_r^{(a)}$ | coefficients appearing in formulae (D-16) and (D-83) respectively |
| $e_1(z)$ | x coordinate of leading edge of fin S_1 at spanwise position z (see Fig 1) |
| $e_2(u), e_3(u)$ | x coordinates respectively of leading edges of half-tailplanes S_2 and S_3 at spanwise position u (see Fig 1) |
| $e_1'(z), e_1''(z)$ | first and second derivatives respectively of $e_1(z)$ |
| $E(x)$ | function defined by formula (C-52) |
| $E_r(\alpha)$ | function defined by formula (F-13) |
| $E_r^{(n)}(\xi; \mu, M)$ | quantity appearing in formula (B-19) |
| $[E]$ | matrix defined by formula (2-164) |
| $[E_1], [E_2]$ | diagonal matrices with respectively (2-155) and (2-157) as general diagonal element |
| $[E_{10}], [E_{20}]$ | diagonal matrices with respectively (2-154) and (2-156) as general diagonal element |
| $f(z), f(\eta)$ | functions defined by formulae (D-6) and (A-14) respectively |
| $f^{(a)}(z)$ | approximation, defined by formula (D-52), to $f(z)$ |
| $f_{p;r,s}^{(1)}, f_{p;r,s}^{(2)}$ | quantities defined in formulae (2-136) and (2-137) respectively |
| $f_q^{(1)}(x,z)$ | modal function for fin S_1 and mode number q (see formula (2-1)) |
| $f_q^{(2)}(x,u), f_q^{(3)}(x,u)$ | modal functions for half-tailplanes S_2 and S_3 respectively and mode number q (see formulae (2-2) and (2-3)) |

LIST OF SYMBOLS (continued)

| | |
|--|--|
| $\hat{f}_q^{(1)}(x,z), \hat{f}_q^{(2)}(x,u)$ | approximations to $f_q^{(1)}(x,z)$ and $f_q^{(2)}(x,u)$ |
| $\delta f_p^{(1)}(x,z), \delta f_p^{(2)}(x,u)$ | quantities defined by formulae (2-90) and (2-91) respectively |
| $[f]$ | matrix appearing in formula (2-169) and defined immediately before |
| $[f_p^{(1)}], [f_p^{(2)}]$ | row matrices with elements (2-150) and (2-151) respectively |
| $F(\alpha)$ | function defined by formula (F-5) |
| $F_r(A)$ | coefficients appearing in formula (F-15) |
| $F(x,y;\nu,M)$ | function defined by formula (2-22) |
| $F_r^{(n)}(\xi,\sigma;\mu,M)$ | quantity appearing in formula (B-19). See also equation (3-23) |
| $[F]$ | diagonal matrix defined by formula (2-174) |
| $[F_0], [F_1], [F_2]$ | diagonal matrices with respectively (2-178), (2-179) and (2-180) as general diagonal element |
| $g(z)$ | function defined by formula (D-7) |
| $g^{(a)}(z)$ | approximation, given by formula (D-53), to $g(z)$ |
| $G_s^{(m)}(\eta_0), \bar{G}_l^{(\bar{m})}(\eta_0)$ | sets of interpolation polynomials defined by formulae (2-52) and (3-54) respectively |
| $[G]$ | matrix defined by formula (2-185) |
| $G(\alpha)$ | function defined by formula (F-5) |
| $G_r(A)$ | coefficients appearing in formula (F-15) |
| $G_s^{(m)}$ | quantities defined by formulae (2-65) |
| $\bar{G}_k^{(\bar{m})}, G_j^{(m',\bar{m})}$ | quantities defined by formulae (A-41) and (A-47) respectively |
| $G_k(p,q,m)$ | quantities defined by formulae (A-4) |
| $G_r^{(n)}(\xi,\sigma,\mu,M)$ | quantities defined by formula (B-18) |
| $h(z)$ | function defined by formula (D-23) |
| $h^{(a)}(z)$ | approximation, given by formula (D-71), to $h(z)$ |
| $h_r^{(n)}(\xi_0)$ | set of interpolation polynomials defined by formulae (2-51) |
| $H(z)$ | function defined by formula (D-15) |

LIST OF SYMBOLS (continued)

| | |
|--|--|
| $H^{(a)}(z)$ | approximation, given by formula (D-82), to $H(z)$ |
| $H_r^{(n)}$ | quantities defined by formulae (2-63) |
| $[H_1(x_0, z_0)], [H_2(x, u)]$ | row matrices appearing in formula (2-182) and defined immediately afterwards |
| $I(\theta), I_k(\theta)$ | functions defined by formulae (C-31) and (C-33) respectively |
| $I_r^{(n)}(\bar{\xi}_p^{(n_1)}, \chi_q^{(m_1, \bar{m}_1)}, \eta_0; \nu, M)$ | quantity defined by formula (3-21) |
| $I_r^{(n)*}(\bar{\xi}_p^{(n_1)}, \chi_q^{(m_1, \bar{m}_1)}, \eta_0; \nu, M)$ | quantity defined by formula (3-22) |
| $J(\theta), J_k(\theta)$ | functions defined by formulae (C-32) and (C-34) respectively |
| $J_r^{(n)}(\bar{\xi}_p^{(n_2)}, \chi_q^{(m_2, \bar{m}_2)}, \eta_0; \nu, M)$ | quantity defined by formula (3-42) |
| $J_r^{(n)*}(\bar{\xi}_p^{(n_2)}, \chi_q^{(m_2, \bar{m}_2)}, \eta_0; \nu, M)$ | quantity defined by formula (3-42a) |
| $k(z), k_r^{(n)}(\xi_0)$ | functions defined by formulae (D-8) and (B-39) respectively |
| $k^{(a)}(z)$ | approximation, defined by formula (D-55), to $k(z)$ |
| $K_1(x, y; \nu, M)$ | subsonic kernel function defined by formula (2-20) |
| $K_2(x, u, v, \theta; \nu, M)$ | subsonic kernel function defined by formula (2-21) |
| l | typical linear dimension of the fin-tailplane configuration |
| $l(z)$ | function defined by formula (D-21) |
| $l^{(a)}(z)$ | approximation, defined by formula (D-63), to $l(z)$ |
| $l_r, l_r^{(a)}$ | coefficients appearing in formulae (D-22) and (D-64) respectively |
| $l_n(\xi_0)$ | a polynomial of degree n in ξ_0 satisfying equations (2-60) |
| $\hat{l}_q^{(1)}(x_0, z_0), \hat{l}_q^{(2)}(x_0, u_0)$ | approximations (2-56) and (2-57) to the respective loading functions $l_q^{(1)}(x_0, z_0; \nu, M)$ and $l_q^{(2)}(x_0, u_0; \nu, M)$ |
| $\hat{\bar{l}}_p^{(1)}(x, z), \hat{\bar{l}}_p^{(2)}(x, u)$ | approximations (2-79) and (2-80) to the respective loading functions $\bar{l}_p^{(1)}(x, z; \nu, M)$ and $\bar{l}_p^{(2)}(x, u; \nu, M)$ |

LIST OF SYMBOLS (continued)

| | | |
|--|---|---|
| $l_q^{(1)}(x, z; v, M)$ | } | loading functions introduced in formulae (2-13), (2-14) and (2-15) respectively |
| $l_q^{(2)}(x, u; v, M)$ | | |
| $l_q^{(3)}(x, u; v, M)$ | | |
| $\bar{l}_p^{(1)}(x, z; v, M), \bar{l}_p^{(2)}(x, u; v, M)$ | solution of integral equations (2-75) and (2-76) | |
| $\delta l_q^{(1)}(x, z), \delta l_q^{(2)}(x, u)$ | quantities defined by formulae (2-88) and (2-89) respectively | |
| $[\hat{l}]$ | column matrix appearing in formula (2-187) and defined immediately before | |
| $[\hat{l}_q]$ | column matrix defined by formula (2-173) | |
| $[\hat{l}_q^{(1)}(x_0, z_0)]$ | the 1×1 matrix with element $\hat{l}_q^{(1)}(x_0, z_0)$ | |
| $[\hat{l}_q^{(2)}(x, u)]$ | the 1×1 matrix with element $\hat{l}_q^{(2)}(x, u)$ | |
| $[\hat{l}^{(1)}(x_0, z_0)], [\hat{l}^{(2)}(x, u)]$ | row matrices appearing in formula (2-188) and defined immediately before | |
| $[\hat{l}_q^{(0)}], [\hat{l}_q^{(1)}], [\hat{l}_q^{(2)}]$ | column matrices with elements (2-175), (2-176) and (2-177) respectively | |
| $L(\eta)$ | function defined by formula (E-4) | |
| $L_{k-1}(\xi_0)$ | function defined by formula (C-21) | |
| $L^{(1)}(x, z, t), L^{(2)}(x, u, t)$ | } normal pressure force per unit area respectively across the fin S_1 and the half-tailplanes S_2 and S_3 | |
| $L^{(3)}(x, u, t)$ | | |
| $L(x, y; v, M)$ | quantity defined by formula (B-10) | |
| $\hat{L}(\xi, \sigma; \mu, M)$ | quantity defined by formula (B-16) | |
| m | number of spanwise loading functions | |
| m' | number of spanwise integration points | |
| \bar{m} | number of integration points related to m' by formula (3-5) | |
| m_1, m_2 | number of spanwise loading functions on the surfaces S_1 and S_2 respectively | |
| m'_1, m'_2 | number of spanwise integration points on the surfaces S_1 and S_2 respectively | |
| \bar{m}_1, \bar{m}_2 | defined by formulae (3-15) and (3-36) respectively | |
| M | Mach number of mainstream. See formula (2-16). Also integer used in Appendix D | |

LIST OF SYMBOLS (continued)

| | |
|---|---|
| $M_r(A)$ | coefficients appearing in formula (F-16) |
| $M_r^{(n)}(\bar{\xi}_p^{(n_1')}, \chi_q^{(m_1', \bar{m}_1)}, \eta_0; \nu, M)$ | quantity defined by formula (3-50) |
| n | number of chordwise loading functions |
| n_1', n_2' | number of chordwise integration points on the surfaces S_1 and S_2 respectively |
| $N_r(A)$ | coefficients appearing in formula (F-16) |
| $N^{(1)}(x, z, t), N^{(2)}(x, u, t) \left\{ \right.$ $N^{(3)}(x, u, t)$ | normal displacement functions (see formulae (2-1), (2-2) and (2-3)) |
| $N_r^{(n)}(\bar{\xi}_p^{(n_1')}, \chi_q^{(m_1', \bar{m}_1)}, \eta_0; \nu, M)$ | quantity defined by formula (3-51) |
| P | number of modes of oscillation |
| $P_r(u)$ | Legendre polynomial of degree r in u |
| $P_r^{(n)}(\bar{\xi}_p^{(n_2')}, \chi_q^{(m_2', \bar{m}_2)}, \eta_0; \nu, M)$ | quantity defined by formula (3-64) |
| $\hat{Q}_{pq} = \hat{Q}'_{pq} + i\nu\hat{Q}''_{pq}$ | approximation (2-84) to the generalised airforce coefficient $Q_{pq}(\nu, M)$ |
| $Q_{pq}(\nu, M)$ | generalised airforce coefficients, defined by formulae (2-26) |
| $[\hat{Q}]$ | matrix appearing in formula (2-169) and defined immediately before |
| $[\hat{Q}_{pq}]$ | the 1×1 matrix with element \hat{Q}_{pq} |
| $Q_{k-2}(\xi_0)$ | a polynomial of degree $(k-2)$ in ξ_0 , introduced in formula (C-30) |
| $Q(x, y; \nu, M)$ | quantity defined by formula (F-2) |
| $Q_r^{(n)}(\bar{\xi}_p^{(n_2')}, \chi_q^{(m_2', \bar{m}_2)}, \eta_0; \nu, M)$ | quantity defined by formula (3-65) |
| $R = R(x, y, \beta)$ | quantity defined by formula (2-24) |
| $R_r(A)$ | coefficients appearing in formula (F-9) |
| s_1, s_2, s_3 | spans of the surfaces S_1, S_2 and S_3 respectively |
| S_1 | planform of fin |
| S_2, S_3 | planforms of port and starboard half-planes respectively |

LIST OF SYMBOLS (continued)

| | |
|---|---|
| $S_r^{(n)}(\bar{\xi}_p^{(n_2)}, \chi_q^{(m_2, \bar{m}_2)}, \eta_0; \nu, M)$ | quantity defined by formula (3-74) |
| t | time |
| $T_r(x)$ | Chebyshev polynomial of degree r in x , defined by formula (C-55) |
| $T_r^{(n)}(\bar{\xi}_p^{(n_2)}, \chi_q^{(m_2, \bar{m}_2)}, \eta_0; \nu, M)$ | quantity defined by formula (3-75) |
| u | local spanwise coordinate for surfaces S_2 and S_3 |
| $u_s^{(m_2)}, u_q^{(m_2, \bar{m}_2)}$ | quantities defined by formulae (2-143) and (3-39) respectively |
| v | speed of the main stream |
| $[w]$ | matrix appearing in formula (2-169) and defined immediately before |
| $\begin{bmatrix} w_q^{(1)} \\ w_q^{(2)} \end{bmatrix}$ | column matrices with respectively the elements (2-152) and (2-153) |
| $\hat{w}_q^{(1)}(x, z)$ | approximation (2-68) to the function $w_q^{(1)}(x, z; \nu)$ |
| $\hat{w}_q^{(2)}(x, u)$ | approximation (2-69) to the function $w_q^{(2)}(x, u; \nu)$ |
| $w_{q; i, j}^{(1)}, w_{q; i, j}^{(2)}$ | quantities defined by formulae (2-138) and (2-139) respectively |
| $w_q^{(1)}(x, z; \nu), w_q^{(2)}(x, u; \nu)$ | functions defined by formulae (2-9), (2-10) and (2-11) respectively |
| $w_q^{(3)}(x, u; \nu)$ | |
| $w_{r, s}^{(1,1)}(x, z; \nu, M), w_{r, s}^{(1,2)}(x, z; \nu, M)$ | quantities defined by formulae (2-70) and (2-71) respectively |
| $w_{r, s}^{(2,1)}(x, u, \nu; M), w_{r, s}^{(2,2)}(x, u, \nu; M)$ | quantities defined by formulae (2-72), (2-73) and (2-74) respectively |
| $w_{r, s}^{(2,3)}(x, u, \nu; M),$ | |
| $W^{(1)}(x, z, t)$ | normal component of air velocity on surface S_1 |
| $W^{(2)}(x, u, t), W^{(3)}(x, u, t)$ | normal components of air velocity on the surfaces S_1 and S_2 respectively |
| $W_T(p, q, n)$ | function defined by formula (A-17) |
| x, y, z | rectangular cartesian coordinates of a point relative to a frame fixed with respect to the mean position of the fin-tailplane configuration (see Fig 1) |

LIST OF SYMBOLS (continued)

| | |
|--|---|
| $x_{r,s}^{(1,n,m)}, \bar{x}_{i,j}^{(1,n,m)}$ | quantities defined by formulae (2-141) and (2-142) respectively |
| $x_{r,s}^{(2,n,m)}, \bar{x}_{i,j}^{(2,n,m)}$ | quantities defined by formulae (2-144) and (2-145) respectively |
| $\bar{x}_{p,q}^{(n_1', m_1', \bar{m}_1)}, \bar{x}_{p,q}^{(n_2', m_2', \bar{m}_2)}$ | quantities defined by formulae (3-17) and (3-38) respectively |
| X | quantity defined by formula (F-3) |
| $z_s^{(m_1)}, z_q^{(m_1', \bar{m}_1)}$ | quantities defined by formulae (2-140) and (3-18) respectively |
| α | dihedral angle (see Fig 2) |
| β | $= \sqrt{(1 - M^2)}$ |
| $\gamma_{m-1}(\eta_0)$ | a polynomial of degree (m-1) in η_0 satisfying the relations (2-61) |
| $\gamma_r(p, q, \eta)$ | a polynomial of degree r in η satisfying the orthogonality relations (A-1) |
| $\Gamma(q)$ | the gamma function |
| δ | an arbitrary positive number which satisfies the inequalities (B-30) |
| δ_{rk} | Kronecker's delta, defined in formula (2-55) |
| $\zeta_k^{(\bar{m})}$ | set of \bar{m} points in (0,1), defined by formulae (A-40) |
| η | parametric coordinate defined by formulae (2-30), (2-34) and (2-38) |
| η_0 | parametric coordinate defined by formulae (2-28), (2-32) and (2-36) |
| $\eta_j^{(m)}$ | set of m points in (0,1), defined by formulae (A-37a) and (A-37b) |
| $\eta_j(p, q, r)$ | zero of the polynomial $\gamma_r(p, q, \eta)$ |
| θ, θ_0 | angles defined implicitly by the formulae (C-35) and (C-9) respectively |
| $\theta_{q;i,j}^{(1)}, \theta_{q;i,j}^{(2)}$ | quantities defined by formulae (2-94) and (2-95) respectively |
| $[\lambda_q]$ | column matrix defined by formula (2-107) |

LIST OF SYMBOLS (concluded)

| | |
|--|--|
| $[\lambda_q^{(0)}], [\lambda_q^{(1)}], [\lambda_q^{(2)}]$ | column matrices appearing in formula (2-107) and defined immediately afterwards |
| Λ | matrix defined by formula (2-109) |
| $\left. \begin{array}{l} [\Lambda^{(0,0)}], [\Lambda^{(0,1)}], [\Lambda^{(0,2)}], \\ [\Lambda^{(1,0)}], [\Lambda^{(1,1)}], [\Lambda^{(1,2)}], \\ [\Lambda^{(2,0)}], [\Lambda^{(2,1)}], [\Lambda^{(2,2)}] \end{array} \right\}$ | matrices appearing in formula (2-109) and defined immediately afterwards |
| μ | arbitrary variable, used in the definition (B-16) of function $\hat{L}(\xi, \sigma; \mu, M)$ |
| $[\mu_p]$ | row matrix defined by formula (2-108) |
| $[\mu_p^{(0)}], [\mu_p^{(1)}], [\mu_p^{(2)}]$ | row matrices appearing in formula (2-108) and defined immediately afterwards |
| $v = (\omega l / V)$ | frequency parameter |
| ξ | parametric coordinate defined by formulae (2-29), (2-33) and (2-37) |
| ξ_0 | parametric coordinate defined by formulae (2-27), (2-31) and (2-35) |
| $\xi_r^{(n)}$ | set of n points in (0,1) defined by formulae (2-66) |
| $\bar{\xi}_p^{(n_1)}, \bar{\xi}_p^{(n_2)}$ | quantities defined by formulae (3-19) and (3-40) respectively |
| $\epsilon_1(x, z_0)$ | quantity defined by formula (B-12) |
| ρ | air density in the main stream |
| $\sigma(z, z_0)$ | quantity defined by formula (B-13) |
| $\phi_{p;r,s}^{(1)}, \phi_{p;r,s}^{(2)}$ | quantities defined by formulae (2-96) and (2-97) respectively |
| $\chi_j^{(m', \bar{m})}$ | set of m' points in (0,1) defined by formula (3-6) |
| $\left. \begin{array}{l} \psi_{i,j;r,s}^{(1,1)}, \psi_{i,j;r,s}^{(1,2)}, \psi_{i,j;r,s}^{(2,1)} \\ \psi_{i,j;r,s}^{(2,2)}, \psi_{i,j;r,s}^{(2,3)} \end{array} \right\}$ | quantities defined by formulae (2-98) to (2-102) |
| ω | circular frequency of harmonic oscillation |

REFERENCES

- | <u>No.</u> | <u>Author</u> | <u>Title, etc</u> |
|------------|--|---|
| 1 | D.E. Davies | Generalised aerodynamic forces on a T-tail oscillating harmonically in subsonic flow. ARC R&M No.3422 (1964) |
| 2 | A.H. Flax | Reverse flow and variational theorems for lifting surfaces in non-stationary compressible flow. J. Ae. Soc., Vol.20, No.2, p.120 (1953) |
| 3 | D.E. Davies | An application of Flax's variational principle to lifting-surface theory. ARC R&M No.3564 (1967) |
| 4 | V.J.E. Stark | Aerodynamic forces on a combination of a wing and a fin oscillating in subsonic flow. SAAB TN 54 (1964) |
| 5 | R.J. Zwaan | Calculated results for oscillating T-tails in subsonic flow and comparison with experiments. NLR Report MP 253 (1967) |
| 6 | G. Böhm H. Schmid | Subsonic unsteady airloads on multiple lifting surfaces. AGARD Conference Proceedings, No.8, Paper 3, November 1970 |
| 7 | K. Isogai | Lifting surface theory for an oscillating T-tail. AIAA Journal, Vol.12, No.1, pp.23-37 (1974) |
| 8 | V.J.E. Stark | Application of the polar coordinate method to oscillating wing configurations. SAAB TN 69 (1973) |
| 9 | W.P. Rodden J.P. Giesing T.P. Kálmán | New developments and applications of the subsonic doublet-lattice method for nonplanar configurations. AGARD Conference Proceedings No.8, Paper 4, November 1970 |
| 10 | G.H.F. Nayler R.H. Doe | A vortex-lattice method for interfering lifting surfaces in steady and unsteady subsonic flow. BAC/D/M/277 (1978) |

REFERENCES (concluded)

- | <u>No.</u> | <u>Author</u> | <u>Title, etc</u> |
|------------|---|--|
| 11 | D.E. Davies | Theoretical determination of subsonic oscillatory air-force coefficients. ARC R&M No.3804 (1976) |
| 12 | Doris E. Lehrian H.C. Garner | Theoretical calculation of generalised forces and load distributions on wings oscillating at general frequency in a subsonic stream. ARC R&M No.3710 (1971) |
| 13 | P.J. Zandbergen T.E. Labrujere J.G. Wouters | A new approach to the numerical solution of the equation of subsonic lifting surface theory. NLR Report TR G.49 (1967) |
| 14 | R. Courant D. Hilbert | Methods of mathematical physics. Vol.1, pp.90, 91, Interscience Publishers Inc. |
| 15 | C.W. Clenshaw | Chebyshev series for mathematical functions. NPL Mathematical Tables, Vol.5 (1963) |

Fig 1

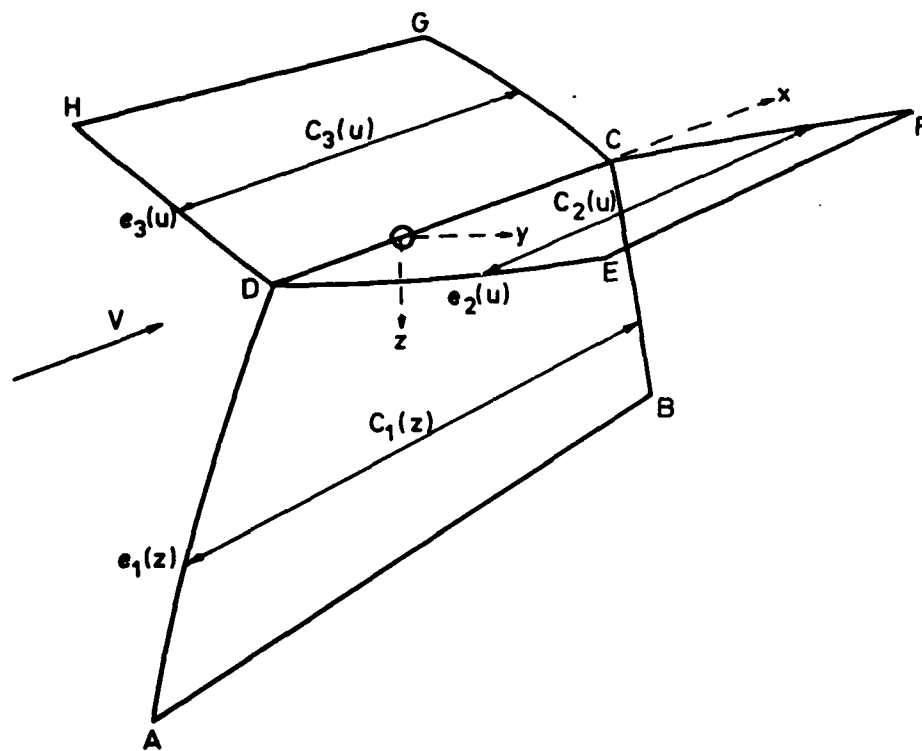

TR 79126

Fig 1 Diagram of fin-tailplane configuration

Fig 2

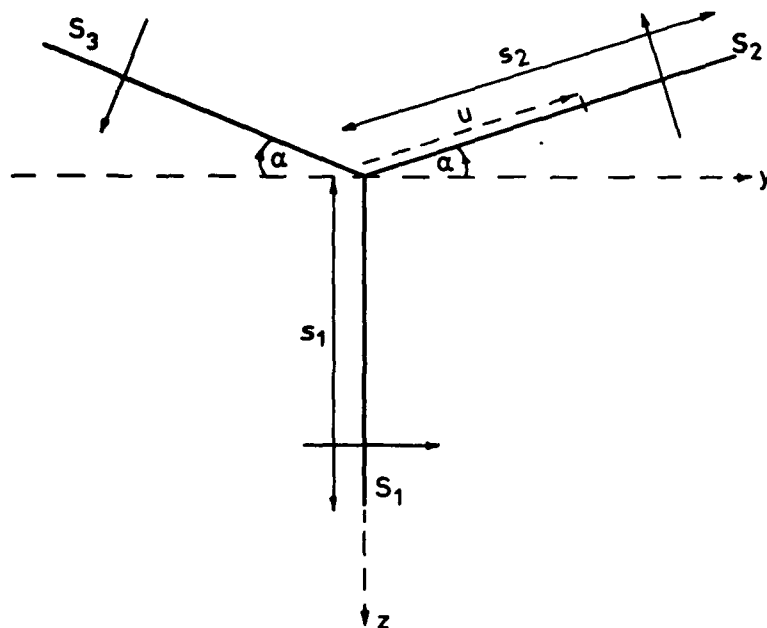

α is the dihedral angle, positive in the sense shown

Displacements normal to the surfaces S_1 (fin), S_2 (positive half-tailplane), S_3 (negative half-tailplane) and loadings on these surfaces are reckoned positive in the directions shown by the normal arrows

Fig 2 Section through the fin-tailplane configuration

Fig 3

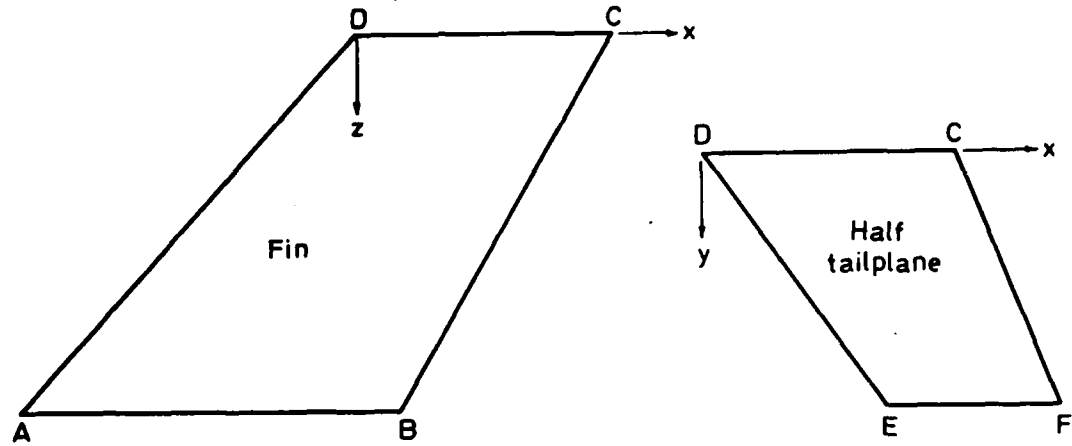

Coordinates

| | x | y | z |
|---|---------|--------|--------|
| A | -1.4034 | 0.0000 | 1.5041 |
| B | 0.1007 | 0.0000 | 1.5041 |
| C | 1.0000 | 0.0000 | 0.0000 |
| D | 0.0000 | 0.0000 | 0.0000 |
| E | 0.7034 | 1.2952 | 0.0000 |
| F | 1.3676 | 1.2952 | 0.0000 |

TR 79126

Fig 3 Planforms of fin and half-tailplane of example 4.3

Fig 4

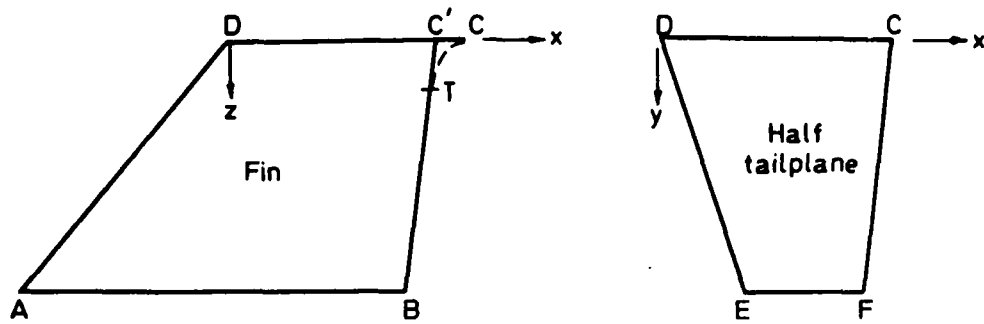

Coordinates

| | x | y | z |
|----|--------|-------|-------|
| A | -0.790 | 0.000 | 1.000 |
| B | 0.500 | 0.000 | 1.000 |
| T | 0.756 | 0.000 | 0.200 |
| C | 0.938 | 0.000 | 0.000 |
| C' | 0.820 | 0.000 | 0.000 |
| D | 0.000 | 0.000 | 0.000 |
| E | 0.340 | 1.000 | 0.000 |
| F | 0.815 | 1.000 | 0.000 |

Fig 4 Planforms of fin and half-tailplane of example 4.4

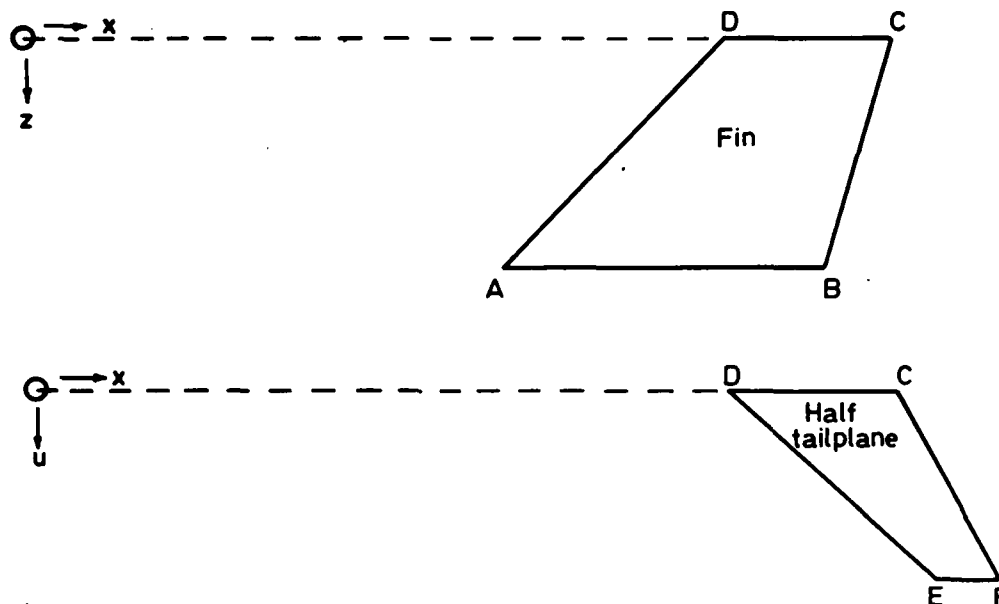

Fin coordinates

| | x | z |
|---|------|------|
| A | 2.50 | 1.20 |
| B | 4.20 | 1.20 |
| C | 4.60 | 0.00 |
| D | 3.70 | 0.00 |

Half tailplane coordinates

| | x | u |
|---|------|------|
| C | 4.60 | 0.00 |
| D | 3.70 | 0.00 |
| E | 4.75 | 1.00 |
| F | 5.10 | 1.00 |

Fig 5 Planforms of fin and half-tailplane of example 4.5

Fig 6

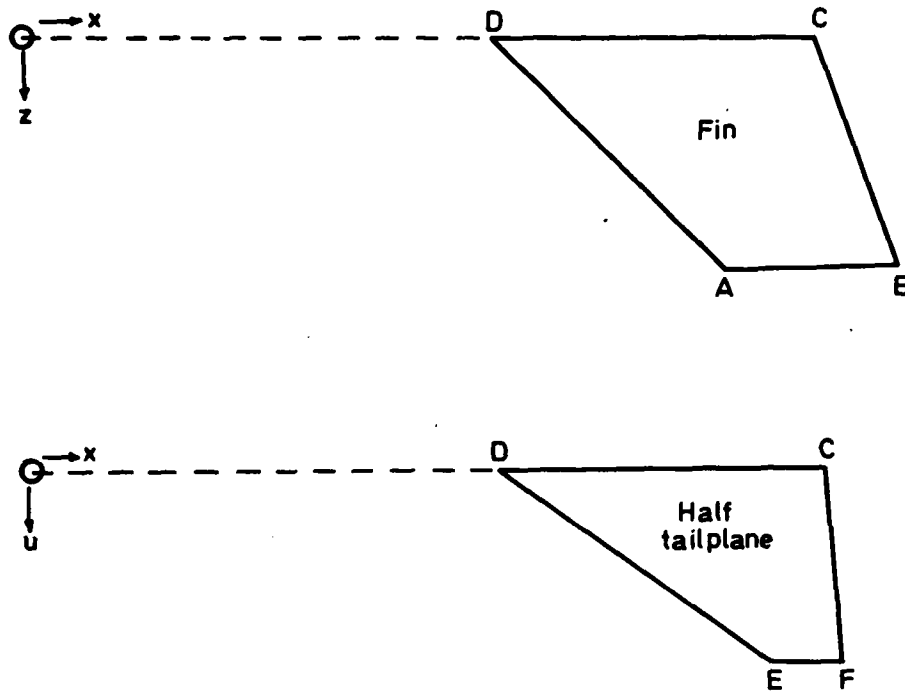

| Fin coordinates | | | Half-tailplane coordinates | | |
|-----------------|------|------|----------------------------|------|------|
| | x | z | | x | u |
| A | 3.70 | 1.20 | C | 4.20 | 0.00 |
| B | 4.60 | 1.20 | D | 2.50 | 0.00 |
| C | 4.20 | 0.00 | E | 3.90 | 1.00 |
| D | 2.50 | 0.00 | F | 4.25 | 1.00 |

Fig 6 Planforms of fin and half-tailplane of example 4.6

REPORT DOCUMENTATION PAGE

Overall security classification of this page

UNCLASSIFIED

As far as possible this page should contain only unclassified information. If it is necessary to enter classified information, the box above must be marked to indicate the classification, e.g. Restricted, Confidential or Secret.

| | | | |
|---|--|----------------------------|---|
| 1. DRIC Reference (to be added by DRIC) | 2. Originator's Reference RAE TR 79125 | 3. Agency Reference N/A | 4. Report Security Classification/Marking UNCLASSIFIED |
| 5. DRIC Code for Originator 7673000W | 6. Originator (Corporate Author) Name and Location Royal Aircraft Establishment, Farnborough, Hants, UK | | |
| 5a. Sponsoring Agency's Code N/A | 6a. Sponsoring Agency (Contract Authority) Name and Location N/A | | |
| 7. Title Theoretical determination of subsonic oscillatory airforce coefficients for fin-tailplane configurations | | | |
| 7a. (For Translations) Title in Foreign Language | | | |
| 7b. (For Conference Papers) Title, Place and Date of Conference | | | |
| 8. Author 1. Surname, Initials Davies, D.E. | 9a. Author 2 - | 9b. Authors 3, 4 - | 10. Date September 1979 |
| | | | Pages 234 |
| | | | Refs. 15 |
| 11. Contract Number N/A | 12. Period N/A | 13. Project | 14. Other Reference Nos. Structures BF/B/0794 |
| 15. Distribution statement (a) Controlled by - (b) Special limitations (if any) - | | | |
| 16. Descriptors (Keywords) (Descriptors marked * are selected from TEST) Subsonic. Fin-tailplane configuration. Dihedral. Oscillatory. Airforce coefficients. Lifting surface. | | | |
| 17. Abstract <p>The fin-tailplane configuration consists of two flat half-tailplanes and a flat fin joined together so as to be symmetric about the plane of the fin. The half-tailplanes may be set at a non-zero dihedral angle to each other. The chords of all the surfaces at their junction are of the same length and are coincident. The fin-tailplane configuration is assumed to be isolated and to be oscillating harmonically about its mean position in a subsonic flow whose main stream is parallel to the junction chord. The oscillatory motion is taken to be antisymmetric about the plane of the fin. Linearised equations of potential flow are assumed to be valid so that the normal velocities on the fin and tailplane surfaces may be related to the loadings on these surfaces by means of linear integral equations. These integral equations are solved numerically for the loadings for oscillation at general frequency in any anti-symmetric modes, and the generalised airforce coefficients are then obtained. Approximations to the loadings are taken as linear combinations of basis functions. The condition satisfied by the loadings at the junction of the fin and half-tailplanes is imposed on the approximations and the variational principle of Flax is applied to get the coefficients in the said linear combinations. The method is more elaborate than that of a previous theory of the author. The procedure has been programmed in ICL 1900 FORTRAN. Results obtained using the program on a number of examples are given.</p> | | | |

F59101

