

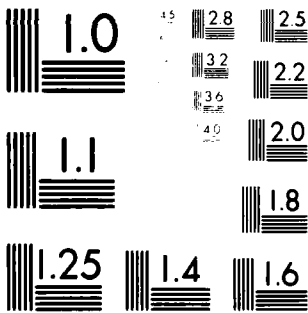

085947



MICROCOPY RESOLUTION TEST CHART  
NBS 1963-A

PHOTOGRAPH THIS SHEET

ADA085947

DTIC ACCESSION NUMBER

II

LEVEL

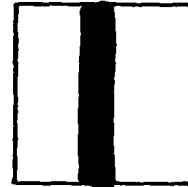

Naval Oceanographic Office INVENTORY  
NSTL Station, Bay St. Louis, MS

Rpt. No. N00-RP-20

DOCUMENT IDENTIFICATION

May 1978

DISTRIBUTION STATEMENT A

Approved for public release;  
Distribution Unlimited

DISTRIBUTION STATEMENT

ACCESSION FOR	
NTIS	GRA&I <input checked="" type="checkbox"/>
DTIC	TAB <input type="checkbox"/>
UNANNOUNCED	<input type="checkbox"/>
JUSTIFICATION	
BY	
DISTRIBUTION /	
AVAILABILITY CODES	
DIST	AVAIL AND/OR SPECIAL
A	

DISTRIBUTION STAMP

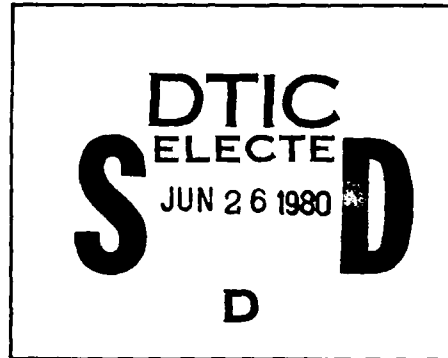

DATE ACCESSIONED

NOTE: Classified references may remain as listed.

Per: Mr. Dale Tidrick,  
N00, NSTL, Bay St.  
Louis, MS  
pfc DDA-2

Empty box for date received in DTIC

DATE RECEIVED IN DTIC

PHOTOGRAPH THIS SHEET AND RETURN TO DTIC-DDA-2

ADA 085947

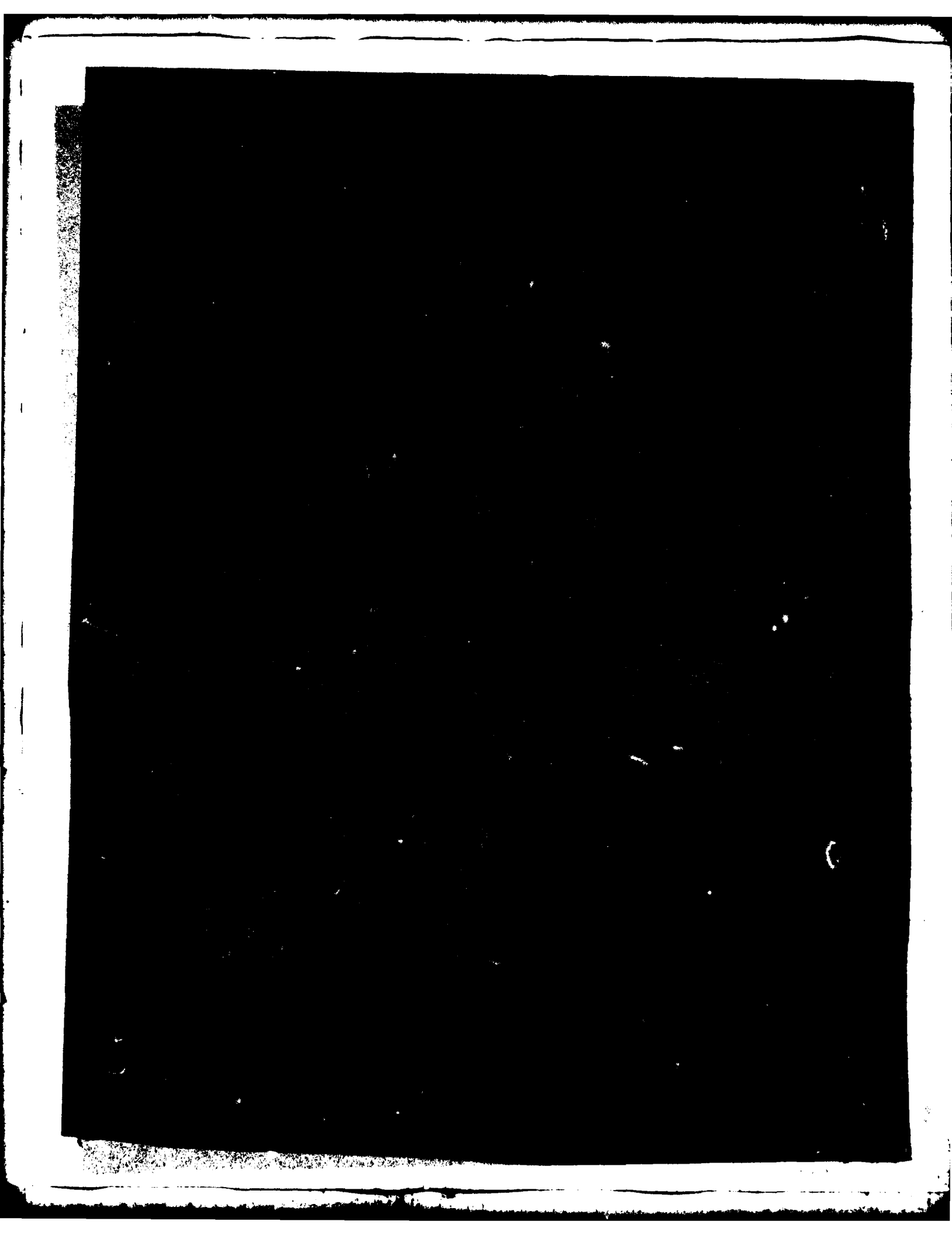

NOO RP-20

# OCEANOGRAPHIC ANALYSIS MANUAL FOR ON-SCENE PREDICTION SYSTEMS

ALVAN FISHER, JR.

MAY 1978



Approved for public release, distribution unlimited.

NAVAL OCEANOGRAPHIC OFFICE  
NSTL STATION  
BAY ST. LOUIS, MS 39522

## FOREWORD

The collection of environmental information by men-of-war dates to the earliest days of the United States Navy. In the past, few of these data were processed immediately; most were logged for later processing and analysis at stations ashore. Modern fleet units do not have this luxury, for they must be able to respond rapidly to any number of possible threats. Thus, it is imperative that forces afloat not only collect environmental data, but process and analyze the data as well. The procedures given in this text provide techniques necessary to convert oceanographic data into a meaningful analysis for subsequent conversion into tactical indices through acoustic performance prediction using systems such as the Integrated Command ASW Prediction System (ICAPS).



J. R. McDONNELL  
Captain, U.S. Navy  
Commander

#### ACKNOWLEDGMENTS

The author wishes to note the many suggestions and guidance provided by G. L. Hanssen. Of equal importance is the assistance in manuscript preparation given by I. Pelaez, D. L. Waters, and A. G. Voorheis. The task was funded as part of the Integrated Command ASW Prediction System (ICAPS) Program under the cognizance of the U. S. Naval Oceanographic Office.

CONTENTS

	Page
I. INTRODUCTION . . . . .	1
II. DATA REQUIREMENTS . . . . .	2
III. THERMAL STRUCTURE DATA SOURCES . . . . .	3
IV. QUALITY CONTROL . . . . .	3
V. OCEANOGRAPHY . . . . .	6
Water Masses . . . . .	6
Oceanic Fronts . . . . .	6
Frontal Acoustics . . . . .	10
VI. ENVIRONMENTAL DATA ANALYSIS . . . . .	10
Environmental Data Collection . . . . .	10
Oceanographic Data Processing . . . . .	11
Acoustic Data Processing . . . . .	13
Plotting and Analysis . . . . .	16
VII. REFERENCES . . . . .	25
FIGURES . . . . .	
1. Worldwide distribution of oceanic fronts . . . . .	9
2. Effect of temperature versus depth in sound speed computations (metric units) . . . . .	14
3. Effect of temperature versus depth in sound speed computations (engineering units) . . . . .	15
4. Sample oceanographic data summary sheet . . . . .	17
5. Rough oceanographic plotting sheet . . . . .	18
6. Smooth SST analysis . . . . .	19
7. Smooth SLD analysis . . . . .	20
8. Smooth water mass analysis . . . . .	22
9. Typical water mass sound speed profiles . . . . .	23
10. Typical water mass propagation loss-versus-range plots . . . . .	24
TABLES	
1. Criteria for rating the relative strength of ocean fronts . . . . .	7

	Page
VIII. APPENDIXES	
A. Bathythermogram Radio Message Format . . . . .	27
B. Examples of XBT Malfunctions . . . . .	35
C. Water Mass Criteria - North Atlantic Ocean/ Mediterranean Sea . . . . .	47
D. Water Mass Criteria - North Pacific Ocean . . . . .	63
E. Water Mass Criteria - Indian Ocean . . . . .	81
F. Glossary of Acronyms . . . . .	93

## I. INTRODUCTION

Effective use of assets available to ASW units requires an awareness of the surrounding environment. This is particularly true of underwater acoustics because of the effect of temperature, salinity, and pressure (depth) on sound velocity. An experienced ASW unit commander recognizes that changes in these parameters and the resulting change in sonar range prediction greatly affects the ability to detect and track potentially hostile submarines. Although oceanographic analyses are available from shore-based Fleet Weather Facilities during periods when electronic emission control is not in effect, they often do not have sufficient data input and detail to be satisfactory. The purpose of this report is to describe some techniques for on-scene analysis of oceanographic data as a necessary step in the preparation of valid and timely acoustical/tactical products.

On-scene analysis of oceanographic data is not new. Experimental analyses were made in support of carrier air groups during the late 1950's. The availability of improved sensors, faster and more efficient computers, and a better understanding of oceanic and acoustic processes requires that the older techniques be updated. It is expected that the techniques described in this publication eventually will be assumed by fully automated systems. Even then, an analyst who understands oceanic processes will be required to evaluate the output. The success of any on-scene sonar range prediction system is predicated on the quality and relevancy of the input data. For example, depth - temperature values input from an expendable bathythermograph (XBT) probe that malfunctioned for any one of a number of reasons may produce unreliable sonar predictions. Similarly, data input representative of Slope Water north of the Gulf Stream would provide misleading predictions if used in the Sargasso Sea. It is the responsibility of the oceanographic/environmental analyst to assure that input data are both accurate and representative of existing conditions. The preparation of a water mass analysis provides a process that examines not only the accuracy of oceanographic data, but establishes the geographic limits of observations with similar characteristics as well. Unfortunately, the analyst frequently has received little training in preparing oceanographic analyses. This text provides a method of oceanographic analysis of relatively small geographic areas--on the order of 200 nmi or smaller--as an integral part of on-scene sonar range prediction, with particular application to automated systems such as the Integrated Command ASW Prediction System (ICAPS).

Material covered in this report is divided among three general topics: (1) collection and quality control of oceanographic data; (2) major oceanographic features, and; (3) analysis of synoptic environmental data to provide near real-time information as to location and characteristics of such features. Because the report is designed as a guide for ICAPS users, it occasionally refers to computer software included in that system such as the deep water mass history. However, most of the text will apply to all systems.

## II. DATA REQUIREMENTS

Environmental information required for sonar range prediction includes a sound speed profile from sea surface to ocean floor, wave heights, depth and acoustic reflectivity of the bottom, ambient noise, and scattering coefficients. The sound speed profile normally is generated by merging a real-time XBT trace with deep historical temperature data, selecting a salinity value for each depth-temperature pair, and converting these data to sound speeds. Most deep histories provide a single set of values for a given area. The ICAPS file, however, provides deep histories for each water mass indigenous to the area under consideration. Description of the ICAPS history and method of combining real-time data with historical data is too complex to include here, but may be found in reference (1)\*.

Water depth and acoustic bottom type are required inputs to compute bottom bounce and convergence zone propagation. The former may be determined either by fathometer or reference to nautical charts. Bottom type--required to determine the amount of energy reflected from the bottom--is input on a 1 to 9 scale for frequencies at or above 1000 Hz with a simplified scale below 1000 Hz (2, 3). Bottom loss type and mean water depth for each prediction area for the Northern Hemisphere and the Indian Ocean may be found on the ASW Prediction Area Charts. These data also are stored in the ICAPS history by 30-minute rectangles, thus enabling the user to default to the history if more accurate positioning is not required.

Ambient noise--the summation of noise caused by waves, precipitation, marine biota, shipping and industrial noises--detracts from the ability to detect potential targets. Ship noise and cavitation are the major sources of ambient noise at frequencies below 50 Hz, whereas sea state usually is the largest contributor at frequencies in the 100 to 5000 Hz range. Depending upon the prediction model used, wind speed or wave height is used as input for estimates of ambient noise in the higher frequency range. Direct ambient noise measurements are possible using the AN/SSQ-57 sonobuoy and certain sonars in the passive mode, but are of limited value because of the rapid variation of ambient noise with respect to time and space and the inadequacies of recording equipment. Tables are available to compute ambient noise as a function of region and wave height (4, 5).

To obtain sonar predictions in the active mode, the analyst must determine the appropriate scattering coefficients. Volume scattering--a measure of the amount of energy reflected by suspended particles in the ocean, fish, and marine organisms--is directly related to the number, type, and distribution of the scatters. Layer scattering is attenuation caused by the millions of marine organisms which form the deep scattering layer. Both scattering coefficients are frequency dependent and vary rapidly with space and time. Because real-time scattering data are seldom available, default values are given in reference (6) based upon values developed at the Fleet Numerical Weather Central (FLENUMWEACEN).

---

\*References will henceforth be indicated by reference number enclosed in parentheses.

### III. THERMAL STRUCTURE DATA SOURCES

Because sound speed profiles are rarely available to operating Fleet units, real-time thermal structure observations are normally used in conjunction with deep historical temperature and salinity data to approximate the sound field. Sources of temperature data include the shipboard expendable bathythermograph (XBT)\*, thermistors mounted on helicopter sonars or submarine sail, airborne expendable bathythermograph (AN/SSQ-36), submarine bathythermograph, mechanical bathythermograph, injection intake thermometer, and infrared imagery from aircraft and satellites. Although few ASW units are able to obtain data reports from all of the above sources, most are available from accompanying units.

As in all instrumentation, the above temperature sensing devices are subject to measurement error. The XBT is the most accurate sensor available to fleet units. It has temperature errors within  $0.2^{\circ}\text{C}$  95 percent of the time and depth errors of 2 percent or 5 m, whichever is greater (7). The SSQ-36 is rapidly approaching the capabilities of the shipboard system, but requires a better readout capability. Because submarine-mounted XBT systems are being introduced to fleet units, a data base to compute error rate and accuracy is not yet available.

Few mechanical bathythermograph observations are made today because of the superiority of the XBT systems. Mechanical BT's are difficult to keep calibrated, are limited to 270-m depths, and require the user to reduce speed to below 15 knots. Injection temperature readings are affected by engine room temperature, frequently read by disinterested engineering personnel, and--because the sensor is located at varying depths below the surface--may not truly represent surface temperature because of the effect of seasonal thermoclines.

Airborne and satellite infrared (IR) imagery require corrections prior to use as sources of surface temperature values. While correction tables are available for the former, none exist for satellite data. In the absence of cloud cover and sea spray they provide superb definition of major oceanic features such as fronts and eddies. Although these data generally are available only to select units; oceanic analyses made using IR data are broadcast to fleet units by facsimile.

### IV. QUALITY CONTROL

All data input to sonar range prediction models or oceanic analyses must be quality controlled to eliminate misleading data. For example, a study of 411 XBT traces encoded during two fleet exercises for transmission to FLENUMWEACEN showed an error rate greater than 60 percent (8). After elimination of encoding errors, the errors fell into three basic types: (1) failure to select depth-temperature pairs

---

\*Bathythermogram data from all sources will be referred to as XBT data because of the predominance of expendable systems.

that were representative of the XBT trace, (2) failure to recognize malfunctioning XBT probes, and (3) positioning errors. If these data were included in an oceanographic/acoustic analysis they could show non-existent oceanic features.

With few exceptions, the process of preparing XBT traces for input into a sonar range prediction model is like that used to encode the XBT trace for transmission as BATHY messages. For this reason instructions for encoding XBT traces are given in Appendix A. The purpose of encoding is to convert a continuous record from an XBT trace to a number of depth-temperature pairs suitable for input to the computer\*. Computer space may limit the number of data points that can be input, e.g., a maximum of 15 points can be used in ICAPS. Although ICAPS input may be in either engineering ( $^{\circ}\text{F}$ , ft.) or metric units ( $^{\circ}\text{C}$ , m), current instructions (9) require that XBT messages forwarded to FLENUMWEACEN be in metric units, thus requiring conversion to metric units during encoding. There appears to be a tendency among observers to record temperature values at constant depths (e.g., 100-m intervals) to reduce the number of values that must be converted. This causes some acoustically important features, such as sound channels, to be missed.

Failure to recognize malfunctioning probes is the most difficult to correct of all error sources. XBT probes frequently are not stowed in upright positions and are left in areas where ambient temperatures are greater than  $32^{\circ}\text{C}$  ( $90^{\circ}\text{F}$ ). Under these conditions, the insulation in the probe cannister melts, causing wire leakage, wire breakage, and uneven unspooling. Contact with the ship's hull or towed sensor, electromagnetic interference from radar and radio transmission, stretching of the wire near the bottom of the trace, and recorder problems also cause erroneous traces. In water shallower than 460 m, the XBT recorder continues to function after the probe strikes bottom. An untrained observer may record this data which, of course, is unreal. Excessive motion of the XBT platform during severe weather, turbulence near water mass boundaries and, in the case of air dropped probes, washover cause malfunctions from natural sources. Examples of common XBT malfunctions are provided in Appendix B to help in recognizing erroneous traces.

Position errors may cause apparent radical departures from actual conditions. For example, an XBT taken north of the Gulf Stream with an erroneous position could cause the analyst to draw a cold eddy south of the Stream. The most common sources of positioning error are transposition of numbers (i.e.,  $57^{\circ}\text{W}$  instead of  $75^{\circ}\text{W}$ ) or erroneous positions. These errors frequently may be corrected by comparison to a dead reckoning (DR) plot of the reporting unit.

---

\*Future on-scene XBT recorders will likely have digitizers to put the data directly into the computer, in which case the operator must edit the trace on a computer display terminal or similar device to eliminate errors caused by the XBT system.

If data are received in BATHY message format, the analyst should plot the trace to assure correctness. The ICAPS program has an editing feature that automatically plots the XBT's input, relieving the analyst of this function. In addition to reviewing position, the analyst must check the encoded depth-temperature pairs for feasibility. Communication garbles, reversed digits, conversion errors, and omission of the 999XX depth indicator can have considerable effect on the data. Depth and temperature errors caused by transposition of numbers (72155 instead of 27155) often can be detected by examining the data immediately above and below the point in question. The best means of detecting erroneous data is by comparison with data that is believed to be correct. These latter data include observations taken in the same area and the seasonal deep history stored in the ICAPS history file. An ICAPS file providing XBT traces typical of each water mass by month is being compiled to provide additional guidance.

When a layer of cold, low salinity water (called a temperature inversion) is found between layers of warmer, more saline water, sonic energy is trapped within the layer forming a sound channel. Well defined sound channels may persist for several months near the boundary of water masses having different temperature-salinity characteristics. Temperature inversions in moderate latitudes rarely occur at depths greater than 100 m, whereas weak inversions ( $0.1^{\circ}$  to  $0.2^{\circ}\text{C}$ ) are found to 400 m or deeper in polar regions. An exception to this rule occurs in the boundary zone between the Kuroshio and Oyashio Currents in the western North Pacific where well-defined inversions occur at depths exceeding 400 m. The analyst should suspect observations that exhibit inversions that are inconsistent with those described above. As a rule of thumb, deep inversions should be ignored, unless the feature is observed repeatedly.

Temperature spikes to the high-temperature side of the trace are caused by leakage in the probe wire and electromagnetic interference. A gradual temperature increase near the bottom of the trace is a result of wire stretch or fictitious data recorded after the probe hits bottom. A sudden temperature increase to the right side of the trace followed by constant or slightly decreasing temperature indicates probe failure. These failures are more obvious than those described in the preceding paragraph and the experienced analyst will have no problem recognizing them.

When minor discrepancies are noted on an XBT trace, the analyst frequently tends to correct data by applying a correction to ensuing depth-temperature pairs. This procedure is not valid and should be used only as a last resort. If data are plentiful, the analyst should disregard an observation that differs markedly from surrounding observations. In the absence of considerable data the analyst cannot eliminate an observation if it is possible that it indicates the presence of mesoscale\* oceanic feature such as an eddy.

---

\*On the order of 100 kilometers in size.

## V. OCEANOGRAPHY

### Water Masses

The near-surface layer of the ocean is not homogeneous, but is divided into numerous water masses, each having a unique temperature-salinity relationship. Thus, water north of the Gulf Stream is readily differentiated from water to the south of the Stream by its relatively low temperature and salinity. At depths of 200 to 300 m--where seasonal change is minimal, but within the depth range of the XBT--water masses can generally be identified from thermal characteristics alone (1). For example, during June 95 percent of sea surface temperatures (SST) in slope water fall in a range of 16.3° to 26.6°C; differing little from the range of 21.4° to 27.6°C found in the Sargasso Sea. However, at a depth of 200 m the ranges differ considerably: 9.4° to 14.5°C in slope water in contrast to 16.5° to 20.0°C in Sargasso water.

Where temperature values at 200 m are similar for adjacent water masses, a second criterion is required to separate them. For example, both Gulf Stream water and Sargasso water have a temperature range of 15° to 25°C at 200 m; however, a layer of near-isothermal water extends to depths exceeding 300 m in the Sargasso Sea, but not in the Gulf Stream. Examination of oceanographic data from the northwestern Sargasso Sea showed that 95% of all observations in that area had a temperature difference between -1.6°C and 0.0°C in the layer between 200 and 300 m. Thus, the temperature difference between 200 and 300 m is used to distinguish Sargasso water from Gulf Stream water. Additional investigation indicated that the temperature difference criterion worked equally well in other areas, and it has been adopted as a 'tie breaker' when temperature criteria are similar at the 200-m level. It should be noted that some water masses occur in the near-surface layer only and do not extend to 200 m. Because these changes occur within the depth range of XBT, a single historical file is sufficient for both water masses.

### Oceanic Fronts

Considerable changes occur in the temperature-salinity structure in both the horizontal and vertical planes in the boundary zones between water masses. These zones--called oceanic fronts--are areas of intense mixing, generally 10 to 50 nmi in width. Surface temperature differences across a strong front, such as the Gulf Stream, may be greater than 10°C with horizontal gradients approaching 2°C/nmi. It is not unusual for multiple gradients to occur in step-like progressions across a front. Salinity difference across a strong front may approach 2 parts per thousand. The different temperature and salinity regimes found on either side of the front cause density gradients across the front so that the lighter water mass forms a wedge above the heavier (denser) water mass. Thus, the front at depth may be offset considerably from the surface expression of the front. Figure 1 shows the worldwide distribution of fronts based on the criteria provided in table 1 (9).

Anomalous features such as upwelling and eddies may occur within a water mass. For example, strong winds accompanying a weather system can cause divergence of surface water, allowing upwelling of cold sub-surface water. Convergence of surface water may cause poorly defined fronts such as those found in the Sargasso Sea. Instability of dynamic features cause wave-like meanders to form and subsequently progress as waves along a front. Warm eddies of Gulf Stream origin may be injected into slope water northwest of the Stream when meanders become unstable. Similarly, extreme meandering of the Gulf Stream similar to the ox bow pattern of old rivers may entrap slope water, thus causing cold eddies in the Sargasso Sea. Eddies range from 50 to 200 nm in diameter and can be expected to retain the circulation pattern of their origin. Eddy life span varies from weeks in the case of a warm eddy to as long as two years for a cold eddy. Although eddies and meanders have most frequently been described along major frontal systems such as the Gulf Stream and the Kuroshio, weaker anomalies no doubt occur near weaker fronts.

Longevity and intensity of fronts and eddies are greatly affected both by existing conditions of contiguous water masses and the overlying atmosphere. Cold eddies, being denser than the surrounding warm water, will sink at a rate of up to 1 m per day. Thus, an old, cold eddy may not be evident from surface observations alone. Surface warming of fronts during summer frequently masks the surface indications of a front; however, subsurface horizontal temperature gradients and sound channels may exist throughout the summer. Warm eddies lose heat to the atmosphere faster than the surrounding cold water in winter with the result that surface cooling may mask the eddy. Masking also occurs in summer when the surface of the surrounding cold water may be warmed to near that of the eddy.

TABLE 1

Criteria\* for rating the relative strength of ocean fronts

	<u>Maximum change in sound speed</u> (m/sec)	<u>Change in Sonic Layer Depth</u> (m)	<u>Depth</u> (m)	<u>Occurrence</u>
Strong	30	150	1000	year-round
Moderate	15-30	30-150	100-1000	year-round
Weak	15	30	100	selected seasons only

\*Table taken from reference (10)

Names of Ocean Fronts Shown in Figure 1

Atlantic Ocean Fronts

- 1 Loop Current (Gulf of Mexico)
- 2 Gulf Stream
- 3 North Atlantic Current (North Polar Front)
- 4 Slope Front
- 5 Sargasso Sea Front
- 6 Subtropical Convergence
- 7 Iceland-Faeroe Islands Front
- 8 Denmark Strait Front
- 9 East Greenland Polar Front
- 10 Greenland-Norwegian Sea Front
- 11 Bear Island Front
- 12 Northwest African Upwelling
- 13 Gulf of Guinea Front
- 14 Guiana Current
- 15 Benguela Upwelling
- 16 Subtropical Convergence
- 17 Antarctic Convergence (South Polar Front)
- 18 Antarctic Divergence

Mediterranean Sea Fronts

- 19 Huelva Front
- 20 Alboran Sea Front
- 21 Maltese Front
- 22 Ionian Sea Front
- 23 Levantine Basin Front

Indian Ocean Fronts

- 24 Somali Upwelling
- 25 Arabian Upwelling
- 26 Indian Ocean Salinity Front
- 27 Equatorial Countercurrent Fronts
- 28 West Australian Front

Pacific Ocean Fronts

- 29 Kuroshio Front
- 30 Yellow Sea Warm Current
- 31 Korean Coastal Front
- 32 Tsushima Current
- 33 Oyashio Front
- 34 Kuril Front
- 35 Subarctic Front
- 36 North Doldrum Salinity Front
- 37 South Doldrum Salinity Front
- 38 Tropical Convergence
- 39 Mid-Tasman Convergence
- 40 Australian Subarctic Front
- 41 Subtropical Front
- 42 California Front
- 43 East Pacific Equatorial Front

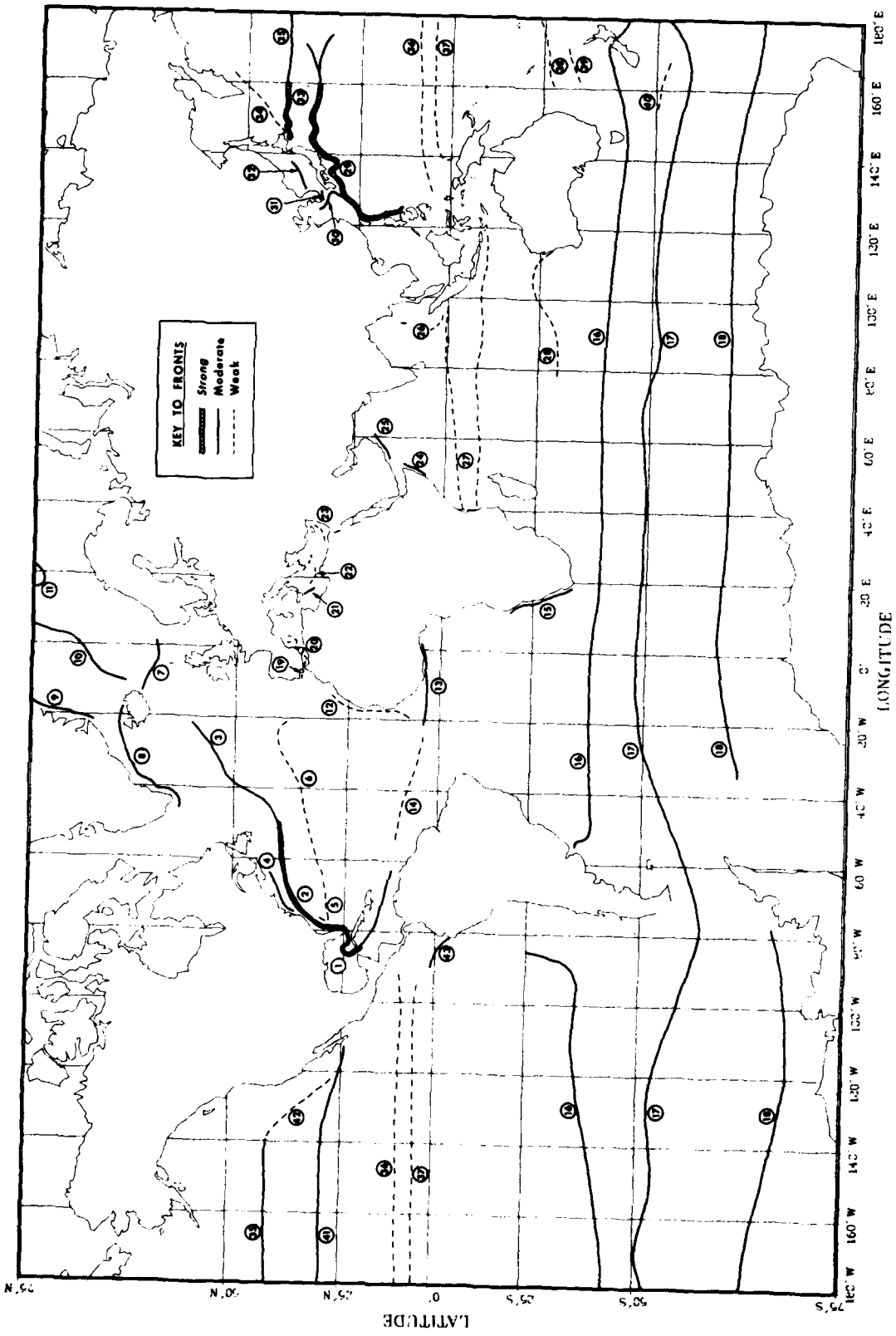

Figure 1. Worldwide distribution of oceanic fronts.

THIS PAGE IS BEST QUALITY PRACTICABLE  
 FROM SOURCE INFORMATION TO AGC

### Frontal Acoustics\*

An oceanographic front is not only a boundary separating temperature-salinity regimes, but also separates acoustic regimes. Because dynamic instability is inherent to frontal regions, acoustic conditions can be expected to vary considerably. Variations that occur during a frontal transit include:

- Surface sound speed may differ as much as 30 m/s on either side of the front.

- Differences in sonic layer depth of 300 m can exist on either side of the front depending upon season.

- Changes in in-layer and below-layer gradients usually accompany changes in surface sound speed and sonic layer depth.

- The depth of the deep sound channel axis may differ by as much as 800 m on either side of the front.

- Increased biological activity generally found along a front will increase ambient noise and scattering.

- Sea-air interaction in a frontal zone can cause a dramatic change in sea state when wind opposes ocean currents, thus increasing ambient noise.

- Refraction of sound rays passing through a front at oblique angles may cause bearing errors.

- Interaction of the water masses on either side of the front may cause near-surface sound channels (temperature inversions).

## VI. ENVIRONMENTAL DATA ANALYSIS

### Environmental Data Collection\*\*

Adequate XBT data coverage in operating areas is needed to delineate water masses, ocean fronts, eddies, and other thermal features that affect sound propagation. However, the limited availability of computer processing time will, in most cases, preclude converting all XBT data collected into sonar range predictions. Even if it were possible to process all XBT data collected, it would be difficult to effectively present all the computed information to users owing to the sheer number of the graphics generated. Therefore, it is important to carefully analyze the ocean environment to determine areas of common thermal structure, ocean fronts, and eddies. Once analyzed, XBT data representative of each water type present can be processed, and products from these data keyed to a water mass boundary chart can be presented to

\*The material in this section is based on a report by Cheney and Winfrey (10).

\*\*Material in this section is based on reference (6).

the user. Processing time may be reduced considerably by use of the ICAPS editing feature. Presently, XBT data must be manually plotted and analyzed to determine which profiles should be submitted for acoustic processing. The Analysis Section is intended to provide guidance in plotting and interpretation of environmental data.

An oceanographic analyst must coordinate the preparation of on-scene XBT data for the computer operator and establish the requirements for specific ICAPS program runs. XBT drops, reported from naval, research, and commercial vessels on a regular basis in the form of BATHY reports (9), provide the best source of oceanographic data. When several escorts are in company, observations usually are taken by assigned BT guardship duty. In addition, AXBT observations may be available from carrier and land-based air groups. Arrangements should be made to assure that information copies of all XBT data are channeled to the oceanographic analyst, since the present OPNAV instructions specify that XBT data can be transmitted directly by at-sea observing units to FLENUMWEACEN (9). Because of the many errors made in encoding BATHY messages the analyst should use the original XBT trace to prepare the analysis, whenever possible.

If the complexity of the ocean environment requires more frequent XBT drops from surface units to adequately delineate water masses in a given operating area, the usual BT guardship concept can be amended to furnish additional data, particularly if the escorts are in close formation. By this amended procedure, drops are made at staggered times so that fewer ships report to the flagship at any one time. For example, destroyer A would make a drop at 0200Z, destroyer B at 0400Z, and continue with subsequent drops at 4-hour intervals thereafter. Such a schedule permits a steady flow of data to the analysis team, eliminates a heavy communication load at the normal reporting time, and permits better sampling of the ocean by a more even distribution of drops. Many destroyers make routine hourly drops when engaged in ASW operations, and these data may be of great value to the environmental teams. It also may be possible to obtain additional data in remote areas by vectoring patrol aircraft to those locations. Observations taken in this manner in future operating areas are particularly useful.

#### Oceanographic Data Processing

Detailed analysis of XBT's to delineate water mass and other thermal features is a complex procedure and entails the predetermination of water mass characteristics and careful matching of observed XBT's to those criteria in order to classify them. The ICAPS program includes routines to automatically classify XBT data by water mass as an aid to on-board analysis. Units without ICAPS can manually analyze the data using Appendixes C through E to determine water mass criteria. Oceanographic data normally plotted include sea surface temperature (SST), sonic layer depth (SLD), and water mass boundaries.

The analyst may wish to plot temperature at the 200-m level (T200)\* and the temperature difference between 200 and 300 m (DT) as an aid in water mass identification, temperatures at selected depths, and temperature gradients (in-layer, below-layer).

The initial step in preparing an analysis is the collection and examination of available data. Obviously, erroneous data should be discarded and questionable data identified. The analyst is encouraged to enter the data in a log such as that shown later in the text, both as an aid in preparation of the analysis and as a record for later reference. It should be noted that all units are given in the metric system in order to be consistent with the current BATHY message format (9). SST is generally available from XBT observations and injection intake thermometer reports. The latter data are particularly subject to errors and must be used with care. Temperature values at specified depths (200 and 300 m in the sample given) and, where desired, additional information are computed.

The temperature difference between 200 and 300 m is computed using the relationship

$$DT = T300 - T200$$

Some analysts like to determine the temperature gradients immediately above and below sonic layer depth to provide a crude measure of refraction of sonic energy. The in-layer temperature gradient giving temperature gradient per hundred meters between the surface and SLD is determined from the relationship

$$ILG = (TSLD - SST) \times 100/SLD$$

The below-layer gradient is normally defined

$$BLG = (TL - TSLD) \times 100/L$$

where L is the thickness of the layer considered below SLD (normal 25 or 30 m) and TL is the temperature at the bottom of that layer.

In each of the above equations the values are adjusted to reflect the gradient per 100 m, thus permitting comparison among observations. Values that differ considerably from neighboring values should be treated with suspicion. Particular variability in thermal structure data can be expected near oceanic fronts. Although XBT traces normally have an isothermal or slightly negative ILG, positive gradients are not unusual in frontal, coastal, and polar regions. An increase of temperature greater than 0.1°C at depths below 200 m should be questioned.

---

\*Hereafter, temperature levels will be indicated by the letter "T" followed by the depth (e.g., T200, TSLD).

### Acoustic Data Processing

Acoustic data normally plotted include SLD, areas where convergence zone (CZ) mode of sonar ranging is possible, and extent and axial depth of near-surface sound channels. Because sound speed data are rarely available to Fleet ASW units, sonic structure is normally estimated from thermal structure data. Therefore, the previous comments on processing of oceanographic data apply equally well to this section.

Sound speed is affected by depth and salinity as well as temperature. Although salinity has relatively little effect, depth (pressure) may have considerable effect on the determination of SLD. Where slightly negative temperature exists, the effect of depth may be sufficient to cause the sound maximum to occur at the bottom of the layer. For example, suppose that a near-isothermal layer occurred with a surface temperature of  $15.1^{\circ}$  and a temperature of  $14.9^{\circ}\text{C}$  at a depth of 50 m. The  $0.2^{\circ}\text{C}$  temperature decrease in the layer causes a decrease in sound speed of 0.6 m/s. However, the effect of the 50-m depth increase causes an increase in sound speed of 0.8 m/s for a net increase of 0.2 m/s. Figures 2 and 3 give the thermal change that can exist at various temperatures without overcoming the effect of depth. In the case of the previous example, enter figure 2 at a depth of 50 m and move horizontally to the nearest temperature line ( $15^{\circ}\text{C}$ ). Then move vertically down to the temperature scale where a value of  $0.26^{\circ}$  is read. Any temperature change less than this ( $0.2^{\circ}$  in the example) is insufficient to override the effect of depth. SLD will thus be at the bottom of the slightly negative temperature layer. If the layer thickness is greater than the maximum depth shown on the graphic (e.g., 260 m), simply solve the problem by using two layers (200 m + 60 m) and add the results.

A similar effect occurs in areas such as the Sargasso and Mediterranean Seas and in the Arctic, where a seasonal thermocline develops above a near-isothermal layer during spring and summer. A sound minimum occurs at the bottom of the seasonal thermocline and the effect of depth overrides the slightly negative temperature gradient forming a so-called 'depressed' sound channel. Figures 2 and 3 again can be used to determine if the near-isothermal layer forms a depressed sound channel. The channel axis will normally be at the top of the layer.

When sound speed near the ocean floor is greater than that at the surface, some of the sonic energy originally refracted downward toward the bottom will be refracted upward toward the surface, forming a convergence zone. Range, width and intensity of the CZ is a function of depth excess; that is, the vertical distance between critical depth\* and the bottom. Depth excess generally must be at least 1000 m if CZ propagation is to be operationally useful. Range to the inner edge of

\*Critical depth is that depth below the deep sound channel axis where sound speed is equal to that at SLD.

METRIC UNITS

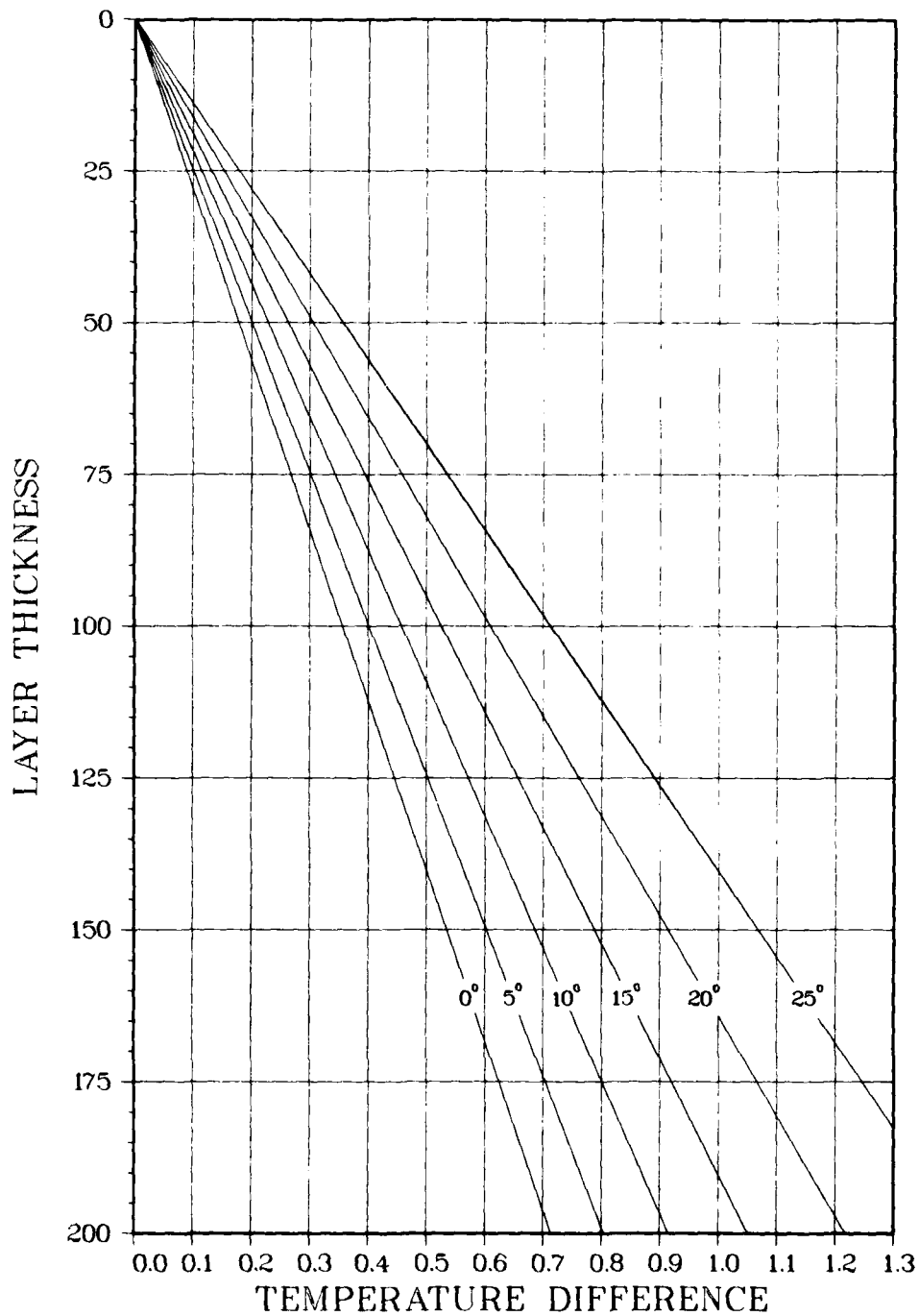

Figure 2. Effect of temperature versus depth in sound speed computations (metric units).

ENGINEERING UNITS

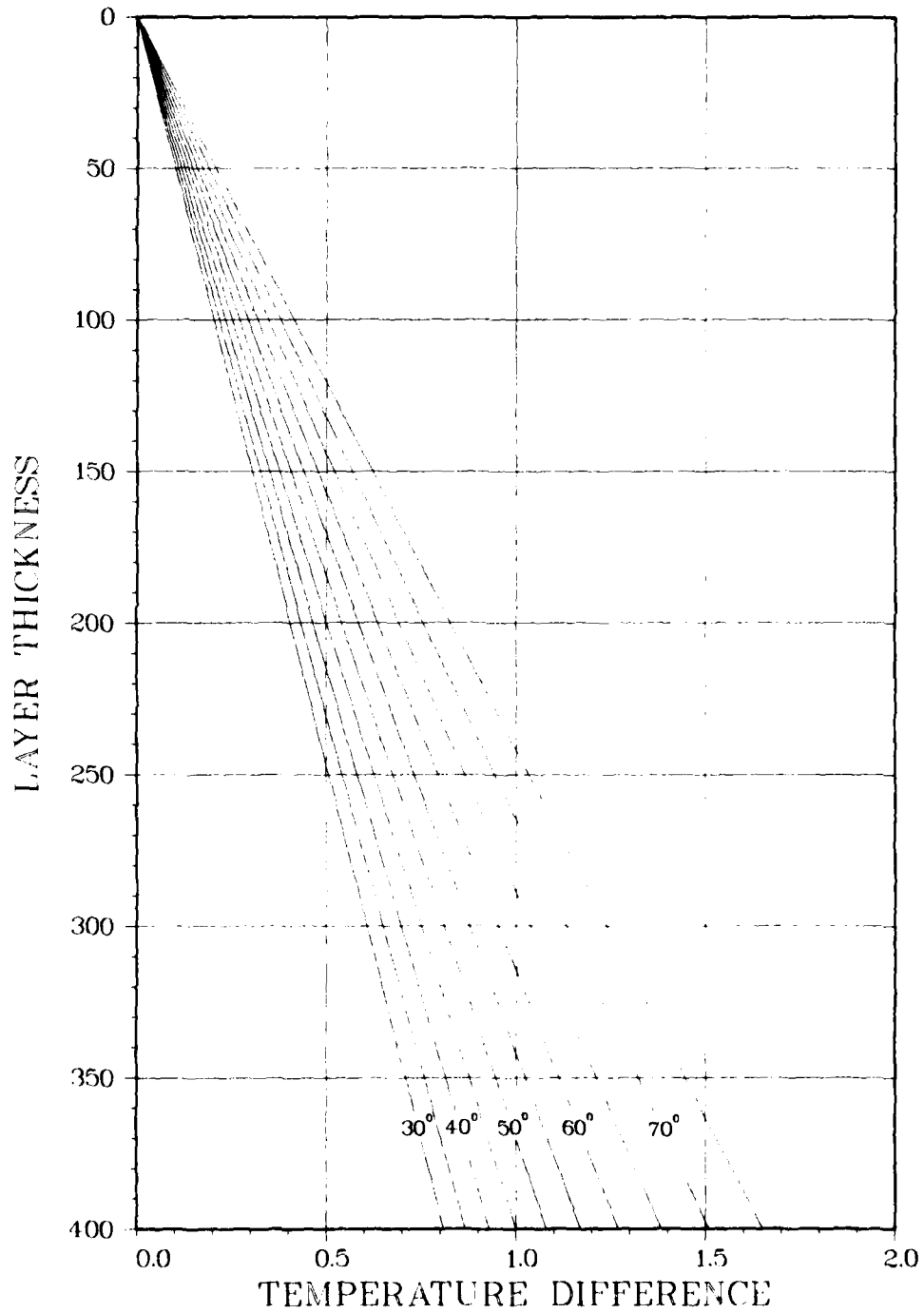

Figure 3. Effect of temperature versus depth in sound speed computations (engineering units).

the first CZ annulus varies between 33 and 70 kyds, depending upon geographic area. Areas of high insonification at ranges less than 33 kyds, or where depth excess is insufficient for CZ propagation, are probably the result of bottom bounce (BB) propagation.

#### Plotting and Analysis

The experienced analyst develops techniques over the years that permit rapid plotting and analysis of environmental data. The following suggestions are provided as an aid in developing these techniques. In the example given only a portion of available data is used. The decision as to what data should be plotted depends upon what information is required for subsequent briefings. For example, determination and plotting of the temperature difference between 200 and 300 m (DT) is meaningless if it is not required for water mass identification.

Choice of plotting base and method of plotting are the prerogative of the analyst. Where a mercator base is desired, nautical charts or plotting sheets are recommended, but graph paper or maneuvering boards also may be used.

Use of a summary sheet may be helpful in preparing the data for plotting. A sample summary sheet is shown as figure 4 with fictitious BATHY and SST data. Data entered on this sheet will be used later to prepare a sample analysis. Ship name, DTG, position, thermal structure data at various levels, SLD, and water mass are generally sufficient. Water mass is determined from Appendix C (North Atlantic Ocean), using T200 and DT. Any observations not meeting the quality control criteria discussed earlier or falling outside water mass criteria given in Appendixes C through E should be used with caution. ICAPS can store XBT profiles during the data processing routine and the analyst can rapidly recall this file. If an XBT probe malfunctioned below the surface layer, SST and SLD may be used if in agreement with surrounding observations.

After this summary sheet has been completed and a preliminary error check made, the data should be transferred to the plotting sheet. Figure 5 shows a plotting sheet with position, DTG, and applicable data entered from the summary sheet. Symbols or colored pencils may be used to identify each ship--again this is the analyst's choice. Position errors are frequently revealed by computing the speed of advance (SOA) between successive observations. For example, an SOA of over 56 kts. is required to achieve the 07/0000 position of the MCCANDLESS as recorded on the sample plot. Therefore, this observation should be discarded if the correct position cannot be determined from other sources (DRT plot, Quartermaster's log, etc). Pertinent information--such as SST, SLD, and water mass--may be plotted either on the base chart or on overlays of tracing paper (figures 6 and 7). It is helpful to analyze SST first because these data are more plentiful, thus permitting definition of the more obvious ocean features. Subsequent analyses--such as the SLD analysis shown--normally are configured to agree with the SST analysis.

SHIP	DTG	LAT	LOX	SST	SLD	T200	T300	DT	W.M.
		N	W	°C	M	°C	°C		
AMERICA	6/2200	37-24	71-13	26.2	35	18.5	11.1	-7.4	GS
	2300	37-27	71-35	25.8	18	18.4	10.8	-7.6	GS
	7/0000	37-31	72-04	15.2	6	12.8	11.4	-1.4	SL
	0100	37-35	72-30	16.3	12	11.9	8.0	-3.9	SL
	0200	37-42	72-56	15.8	11	10.8	10.0	-0.8	SL
BROWN	6/1300	36-50	73-47	16.5	15	12.4	8.3	-4.1	SL
	1400	36-35	73-26	17.0	8	12.9	9.6	-3.3	SL
	1500	36-24	73-03	24.3	30	18.7	12.0	-6.7	GS
	1600	36-13	72-45	25.2	18	18.5	14.8	-3.7	GS
	1700	36-03	72-22	23.0	10	18.3	18.1	-0.2	SA
	1800	36-08	71-55	23.2	15	18.8	18.0	-0.8	SA
	1900	36-24	71-34	23.4	15	18.1	16.6	-1.5	SA
	2000	36-41	71-27	23.7	18	18.2	17.8	-0.4	SA
	2100	36-59	71-30	24.1	20	18.1	12.3	-5.8	GS
	2200	37-14	71-38	26.1	31	17.8	14.8	-3.0	GS
	2300	37-24	71-51	19.3	2	14.9	8.0	-6.9	SL
	7/0000	37-35	72-13	16.0	10	11.8	8.4	-3.4	SL
	0100	37-42	72-38	29.5	8	11.3	10.9	-0.4	SL
MCCAND	6/1800	37-22	73-17	23.2	32	16.1	13.8	-2.3	GS
	1900	37-04	73-05	22.8	20	16.3	13.7	-2.6	GS
	2000	36-49	72-75	19.7	3	13.8	8.8	-5.0	SL
	2100	36-33	72-39	26.0	28	18.3	13.9	-4.4	GS
	2200	36-16	72-21	24.3	10	18.2	16.9	-1.3	SA
	2300	35-57	72-04	23.1	12	18.4	17.6	-0.8	SA
	7/0000	35-38	71-05	22.2	14	18.0	16.7	-1.3	SA
	0100	35-29	72-03	22.1	12	18.1	16.9	-1.2	SA
	0200	35-29	72-22	22.8	15	18.0	17.3	-0.7	SA
	0300	35-28	72-39	23.0	12	18.3	17.8	-0.5	SA
	0400	35-28	73-00	23.1	10	18.2	17.5	-0.7	SA
	0500	35-29	73-08	25.8	30	18.1	11.6	-6.5	GS
	0600	36-50	73-40	23.1	3	14.7	13.3	-1.4	SL
0700	36-12	73-56	17.3	10	12.4	11.5	-0.9	SL	
SHIP	6/2200	36-54	72-55	24.8					
	6/2300	37-30	72-48	16.8					
	6/1900	37-05	73-42	18.6					
	7/1200	36-50	72-30	24.3					
	7/1700	37-00	71-56	25.5					

Figure 4. Sample oceanographic data summary sheet.



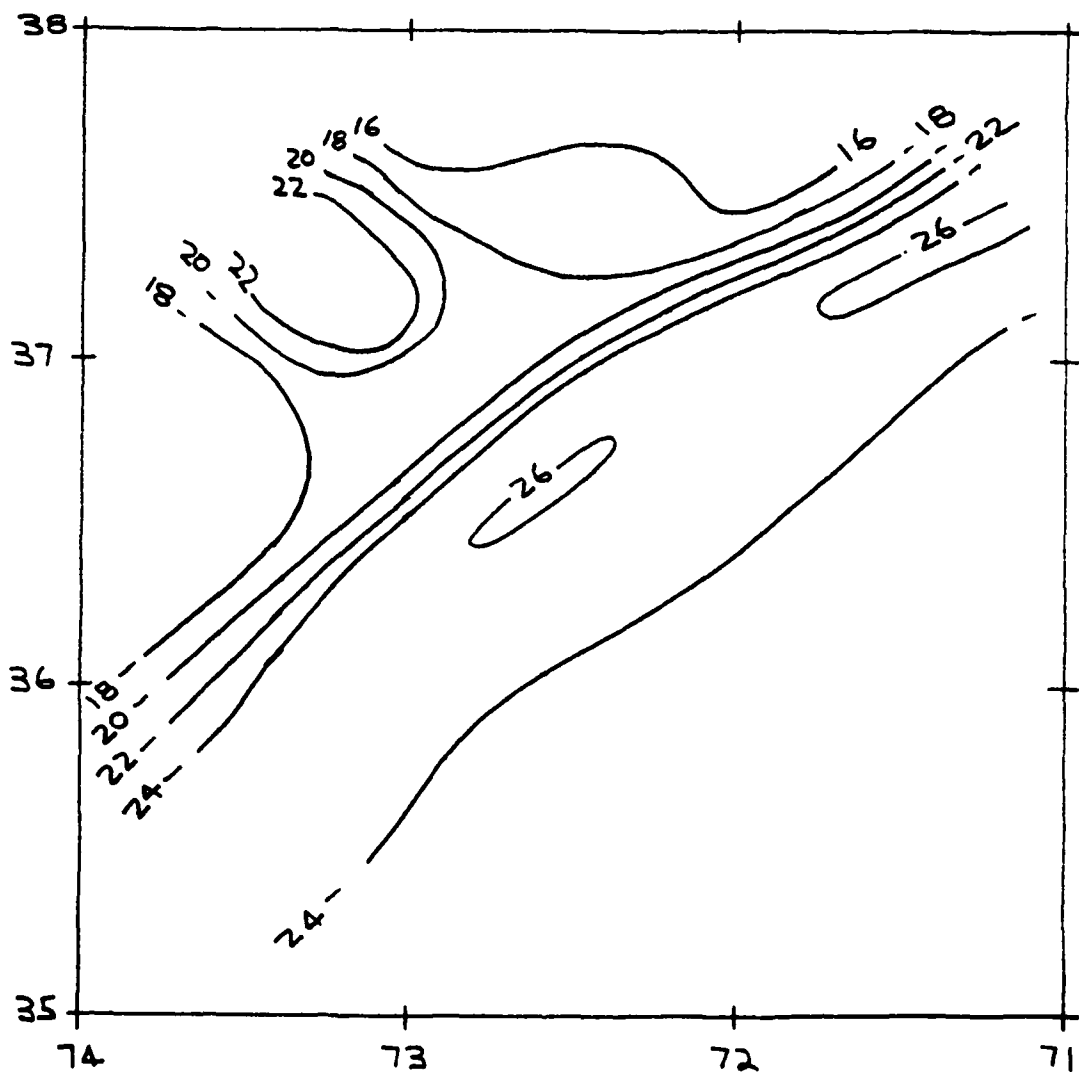

Figure 6. Smooth SST analysis.

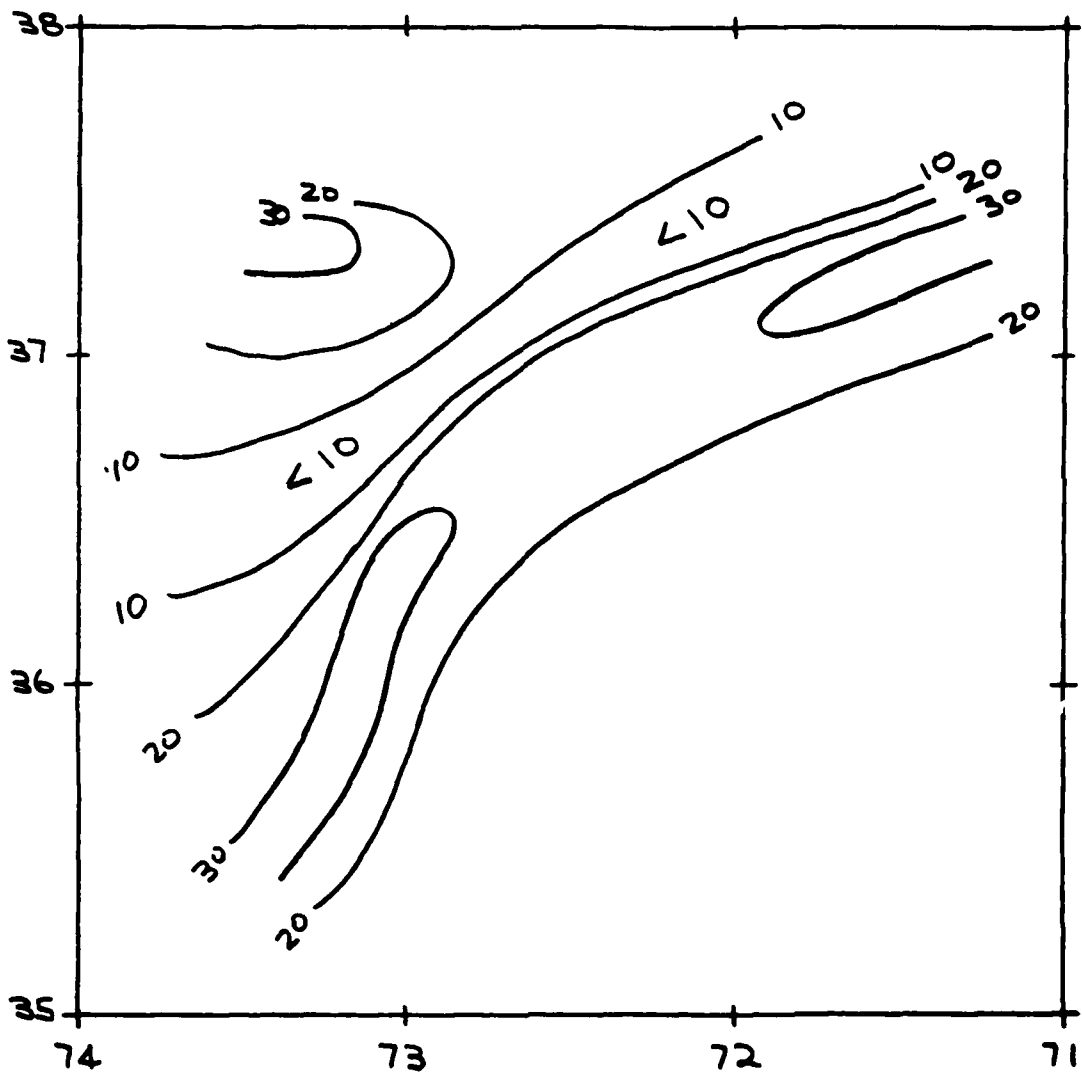

Figure 7. Smooth SLD analysis.

During the plotting and analysis phases the analyst must apply his knowledge of oceanography with respect to (1) elimination of data that vary markedly from other data and (2) the properties of mesoscale oceanic features of the area. For example, the 7/0100 XBT drop made by the BROWN showed an SST of 29.5°C; some 6°C higher than other data in the same general area. Although SLD, T200, and T300 were reasonable, uncertainty as to the accuracy of the observation prohibits its use in the analysis. However, the 6/1800 and 6/1900 data collected by the MCCANDLESS to the southwest of the aforementioned BROWN observation show characteristics of Gulf Stream water. The presence of cold water adjacent to the MCCANDLESS observations indicates that the warm water is isolated from the Gulf Stream as an eddy.

Knowledge of oceanic processes is helpful in maintaining objectivity. In frontal zones, where water masses of different temperature-salinity characteristics occur, it is common for the warmer, more saline (and thus lighter) water to override the colder, less saline water with the result that SLD may approach the surface. In the example given, a zone of near-zero SLD is likely near the oceanic front separating slope water and Gulf Stream water.

The completed water mass analysis (figure 8) can now be drawn. Prior to labeling the analysis, XBT traces representative of each water mass should be selected. In selecting a typical trace the analyst should especially consider shape of the trace, T200, SLD, and SST. Once a trace has been selected, its position should be plotted on the analysis along with identification (A through D in the analysis). Name of water mass and variability of SST and SLD now can be added to the water mass on the analysis.

The full suite of ICAPS acoustical and tactical products can now be made using the representative XBT traces selected for each frequency and source depth/hydrophone depth desired. Other environmental data (wave height, bottom classification, water depth, ambient noise, scattering coefficients) will be required to compute passive and active sonar ranges. Graphics showing sound speed profiles in the near surface layer and propagation loss for each of the typical XBT traces are shown as figures 9 and 10 respectively. (These graphics were taken from a CRT display using a hard copier on the ICAPS mini-computer).

Items such as predicted sonar range (in-layer, cross-layer, below-layer), best depth, areas where CZ or BB modes sonar operation may be used, etc., should be added. The computed data are now available to develop ASW tactics suitable for each water mass. When completed, a briefing package is available providing near real-time environmental and tactical information to operational ASW forces.

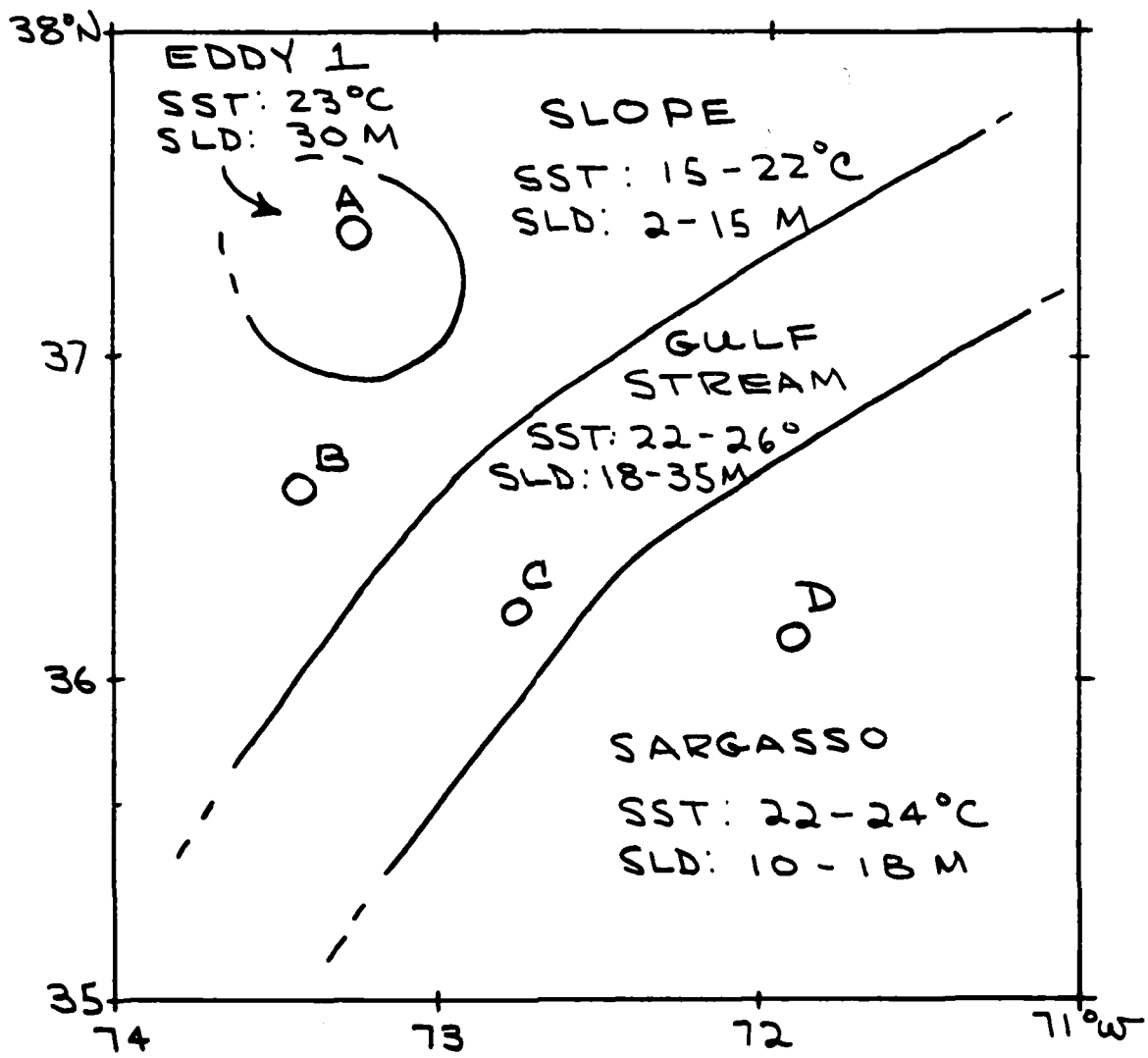

Figure 8. Smooth water mass analysis.

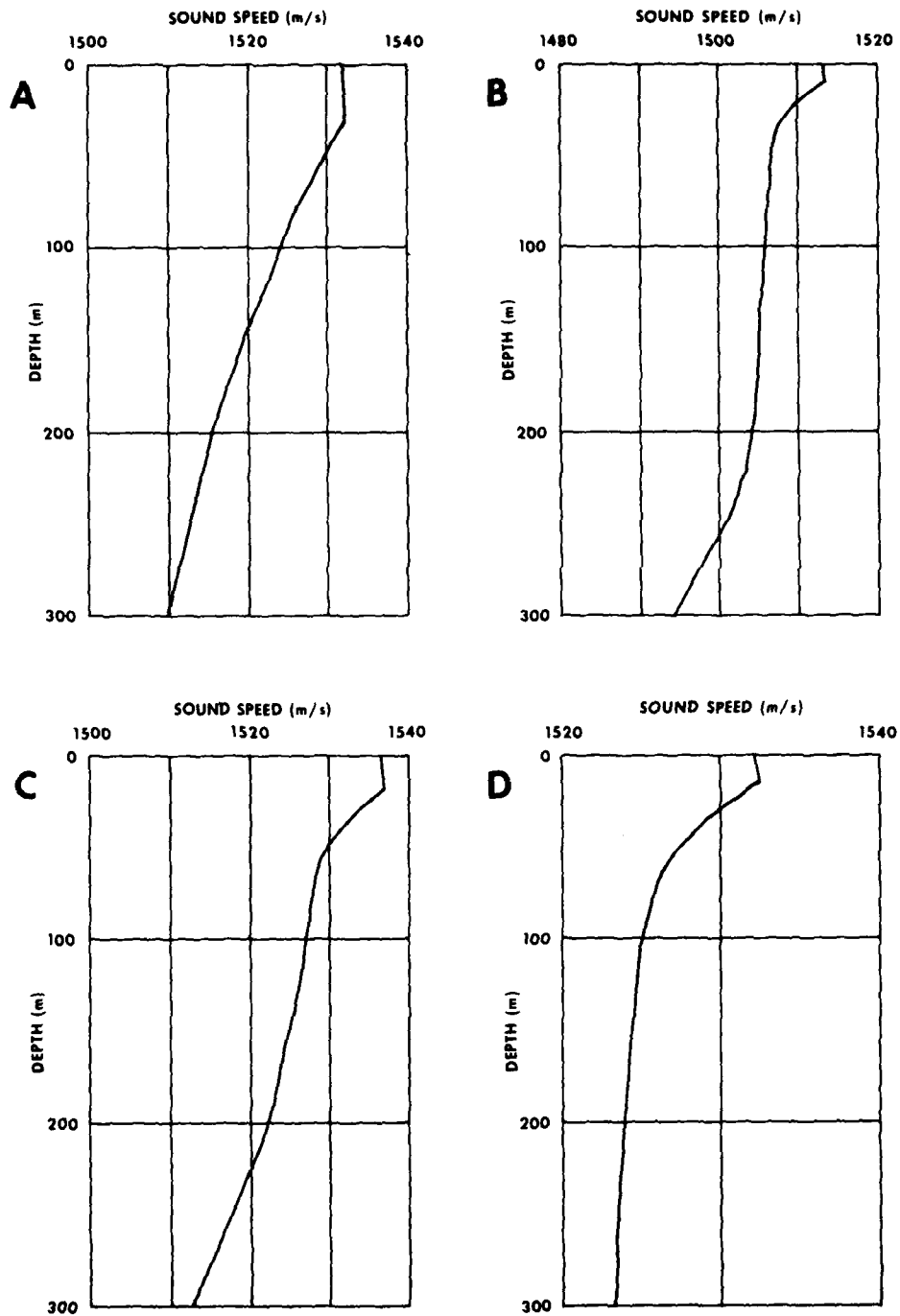

Figure 9. Typical water mass sound speed profiles.

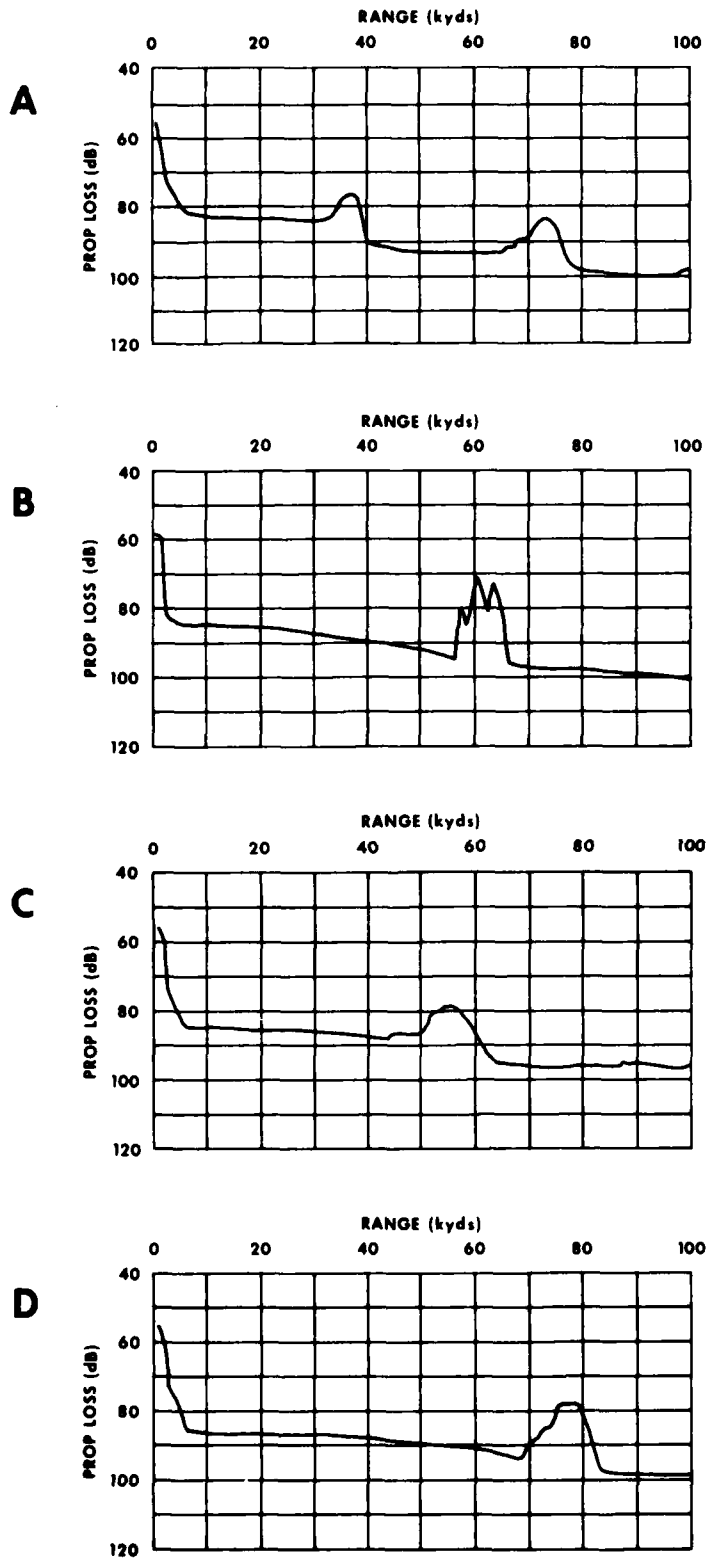

Figure 10. Typical water mass propagation loss-versus-range plots.

VII. REFERENCES

1. Fisher, A., The ICAPS water mass file, Naval Oceanographic Office Reference Publication 19, 1978.
2. Bassett, C. G. and P. M. Wolff, Fleet Numerical Weather Central bottom loss values (U), Fleet Numerical Weather Central, Technical Note 50, Monterey, CA 1970. CONFIDENTIAL
3. Christensen, R. E., J. A. Frank, III, and O. Kaufman, Navy interim standard bottom loss curves at frequencies from 1.0 to 3.5 kHz (U), Naval Oceanographic Office, Special Publication 264, 11 p, 1974. CONFIDENTIAL
4. Wenz, G. W., Acoustic ambient noise in the ocean, spectra and sources. J. Acoustic Society America, 34 (12), pp 1936-1956, 1962.
5. Vidale, M. L. and M. H. Houston, Jr., Estimates of ambient noise in the deep ocean (U), General Oceanology, Inc., Report No. GO-4, 70 p, Cambridge, MA, 1968. CONFIDENTIAL
6. Hanssen, G. L. and W. B. Tucker, III, Interim Integrated Carrier Anti-Submarine Warfare Prediction System (ICAPS) manual, (CP-642-B computer system) (U), Naval Oceanographic Office, Reference Publication 10, 106 p, Washington, DC, 1975. CONFIDENTIAL
7. Pickett, R. L., Precision of sound speed estimated from BTs, J. Mar. Tech. Soc., 6, pp 37-38, 1972.
8. Fisher, A. and L. Riley, An investigation of XBT encoding errors and their effect on sonar range computation, Naval Oceanographic Office, Technical Report 234, 12 p, Washington, DC 1977.
9. OPNAVINST 3160.17 of 18 Feb 1977
10. Cheney, R. E. and D. E. Winfrey, Distribution and classification of ocean fronts, Naval Oceanographic Office, Technical Note 3700-56-76, 12 p, Washington, DC, 1976.



VIII. APPENDIXES

APPENDIX A\*

BATHYTHERMOGRAPH RADIO MESSAGE INFORMATION

A. EVALUATING TRACE FOR RADIO MESSAGE INFORMATION ENTRIES.  
(See SAMPLE RECORDER TRACE fig. C-1)

To facilitate the use of bathythermograph (BATHY) information for synoptic forecasting, the following procedures must be followed:

1. The trace should be read to the nearest tenth of a degree in temperature and to the nearest whole unit of depth. If temperature is in Fahrenheit and/or depth in feet, convert to metric units ( $^{\circ}\text{C}$ , m.).
2. When interpreting and encoding the bathythermograph trace, always include:
  - a. Water temperature at the sea surface (or the first readable temperature in the upper 10 m) and at the deepest point of the trace.
  - b. Sufficient inflection (flexure) points to describe the temperature structure and, in addition, significant irregularities in the surface layer. In the upper 500 m never report more than 20 points. Usually the number of points required to describe the trace in the upper 500 m will be less than 20.
  - c. The top and bottom of isothermal layers.
  - d. Additional intermediate points to support any large temperature/depth differences. The temperature difference between two consecutive depth/temperature entries should never exceed  $3^{\circ}\text{C}$ . All such intermediate points should be read to the nearest whole degree C.
3. Do not adjust the trace to agree with the reference temperature.
4. Do not routinely interpret the trace at the convenient depth increments (5 m, 20 m, etc.) unless inflection points actually exist at those depths.
5. All values must be recorded accurately (every entry must be rechecked).
6. If the instrument strikes the sea bottom read the temperature depth value and report it in RADIO MESSAGE INFORMATION according to SPECIAL CODING INSTRUCTIONS FOR THE 00000 indicator group.

\*This appendix is a reproduction in part of OCEANAVINST 3160.9B of 19 June 1972.

**B. RECORDING THE RADIO MESSAGE INFORMATION**

The following procedures should be followed to enter bathythermograph data on "BATHYTHERMOGRAPH LOG" NOAA Form 77-22 (fig. C-1).

1. Message Prefix - Preprinted JJXX identifies bathythermograph observations.

2. DATE (YYMMJ)

YY Day - Enter the day of month as determined by GMT using numerals 01 through 31.

MM Month - Enter month of year using numerals 01 through 12.

J Year - Enter the last digit of year.

3. TIME (GGgg/)

GG Hour - Enter the GMT hour of observation.

gg Minutes - Enter the GMT time in minutes when bathythermograph entered water.

/ Preprinted symbol.

4. LATITUDE ( $Q_c L_a L_a L_a L_a$ )

$Q_c$  Quadrant of globe - From table C-1 enter the quadrant of globe.

$L_a L_a L_a L_a$  Latitude - Enter latitude in degrees and minutes.

5. LONGITUDE ( $L_o L_o L_o L_o L_o$ ) - Enter longitude in degrees and minutes.

Table C-1. Quadrant of the Globe (U)

CODE	QUADRANT
1	NE
3	SE
5	SW
7	NW

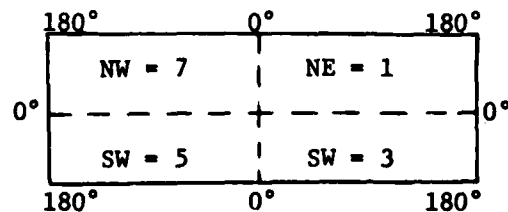

6. INDICATOR GROUP 88888 - Temperatures at significant depths follows:

BATHYTHERMOGRAPH TRACE READINGS

Surface Depth - Temperature ( $Z_0Z_0T_0T_0T_0$ )

$Z_0Z_0$  Water Surface, 00 is preprinted.

$T_0T_0T_0$  Enter the surface water temperature value ( $^{\circ}C$ ) as read from the BT trace to the nearest tenth of a degree. When the temperature trace is unreadable in the first 10 meters enter solidi (///).

$ZZT_zT_zT_z$  This group is repeated as many times as necessary to adequately describe the BT trace.

$ZZ$  For subsurface depth to 99 m enter in whole m the depth at which corresponding temperature values are read from the trace. Example: For 5 m, record 05; for 97 m, record 97.

SPECIAL CODING INSTRUCTIONS

999NN NOTE: Always include a 999NN group before recording depths of 100 m, 200 m and each succeeding 100 m intervals to termination. NN is coded as 01 for 100 to 199 m; 02 for 200 to 299 m, etc. When the 999NN code is entered mark out the  $ZZT_zT_zT_z$  heading.

$ZZ$  For depths between 100 and 200 m, 200 and 300 m, etc., enter the tens and unit digits only. Example: for 101 m, record 01; for 256 m, record 56; for 375 m, record 75.

$T_zT_zT_z$  Temperature Group - Enter water temperature at depth  $ZZ$  in  $^{\circ}C$  to tenths of degrees. All temperature values of less than  $0^{\circ}C$  will be coded at  $5T_zT_z$  (5 indicates that a negative reading follows).

00000 Indicator Group - Inserted after last  $ZZT_zT_zT_z$  group only if last group is an ocean bottom reading.

RADIO CALL All messages must terminate with the ship radio call or aircraft squadron designator or the letters ACFT.

C. HOW TO ADDRESS MESSAGES FOR RADIO TRANSMISSION

Message addresses should be indicated and forwarded as follows :

OBS METEO WASHDC - For all platforms other than Navy and under IOC, IGOSS auspices.

FLENUMWEACEN - For Navy sponsored aircraft and ship observations in accordance with current Navy instructions.

D. INSTRUCTIONS FOR NAVY USE

BATHY messages will be transmitted with PRIORITY precedence, classified in accordance with the ship's movement. The heading on the BATHY radio message is identical to the heading on any Navy message.

For example:

P 250015Z DEC 71  
FM USS BOSTON  
TO RUWJAGD/FLENUMWEACEN MONTEREY  
BT  
UNCLAS  
JJXX etc. . . . .

Navy ships, in addition to filling out the REFERENCE and RADIO MESSAGE INFORMATION sections, will fill in the Navy ship section in the upper left corner of the log sheet as follows:

- 3-4. Enter first two letters of ship type in spaces 3 and 4, and remaining letters as appropriate in the next two shaded unnumbered spaces.
- 5-7. Enter hull number in spaces 5-7; precede by zeroes if less than 3 digits. If hull number is 4 digits, enter the first digit in the shaded unnumbered space.
- 12-14. Enter last digit of current calendar year in space 12. Enter two digit number of current month in spaces 13-14; Example : August 1972 is coded as 208.

Navy aircraft, in addition to filling out the REFERENCE and RADIO MESSAGE INFORMATION sections, will fill in the Navy aircraft section in the upper right corner of the log sheet, as follows:

- 3-4. Enter first two letters of squadron type in boxes 3-4. (Exception : VAW squadrons enter "AW").

- 5-7. Enter squadron number in spaces 5-7; precede by zeroes if less than 3 digits (Exception: detachments enter "D" followed by detachment number).
- 8-11. Enter numbers and/or letters assigned to identify, within a squadron, each sortie of each aircraft.
- 12-14. Enter last digit of current calendar year in space 12. Enter two digit number of current month in spaces 13-14. Example: August 1972 is coded as 208.

Preprinted letters under some of the boxes are for data processing purposes and are not of concern to the bathythermograph operator.

Navy submarines will fill out the RADIO MESSAGE INFORMATION section as follows:

In the Surface Depth-Temperature group (with 00 preprinted in depth group (Z<sub>0</sub>Z<sub>0</sub>); enter 999 in temperature group T<sub>0</sub>T<sub>0</sub>T<sub>0</sub> to indicate submarine observations.

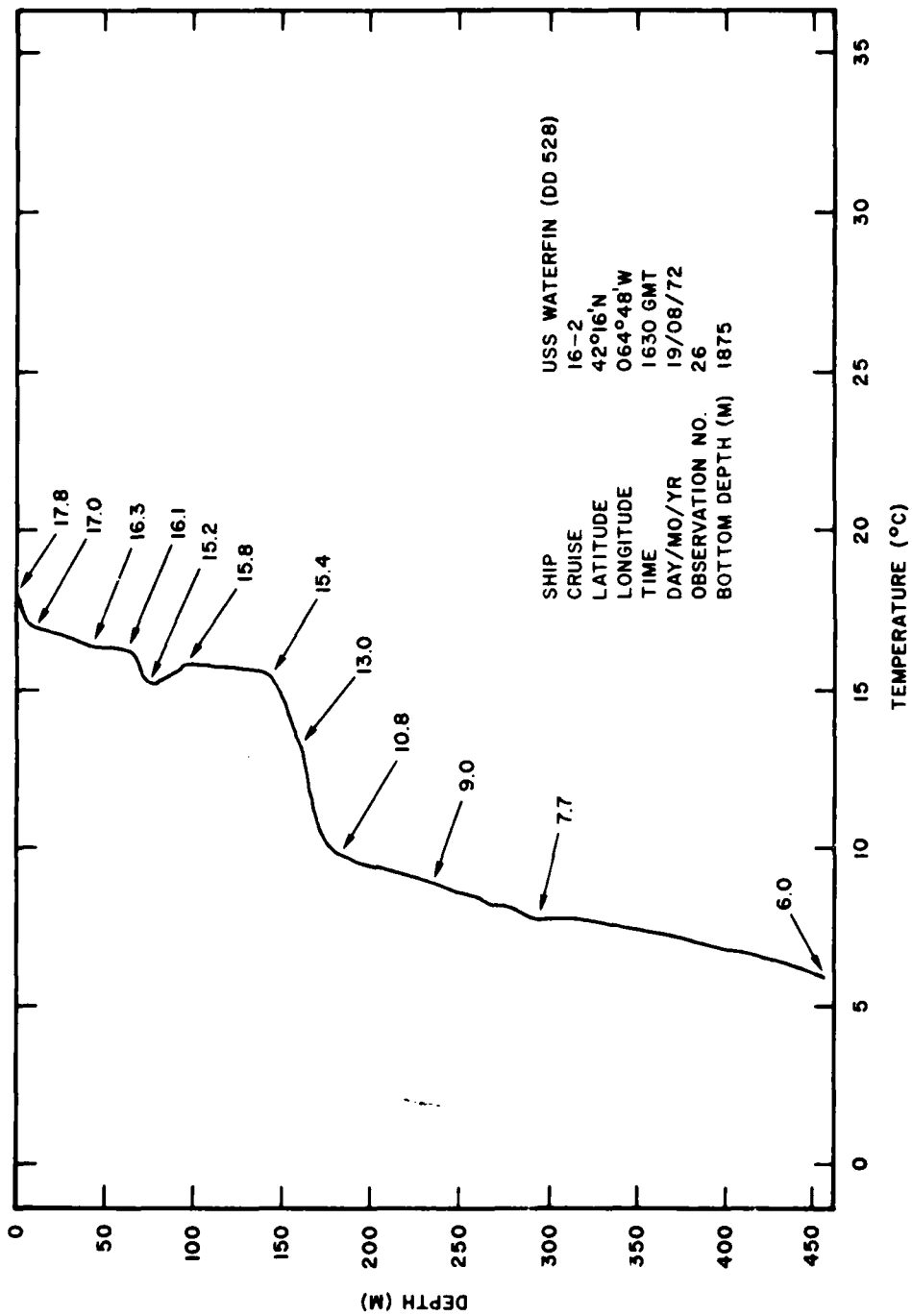

FIGURE C-1. SAMPLE RECORDER TRACE

# BATHYTHERMOGRAPH LOG

Prepared by the OCEANOGRAPHER OF THE NAVY  
and the NATIONAL OCEANIC AND ATMOSPHERIC ADMINISTRATION  
in accordance with specifications established by the  
INTERGOVERNMENTAL OCEANOGRAPHIC COMMISSION (IOC)  
and WORLD METEOROLOGICAL ORGANIZATION (WMO)

FOR NAVY SHIP USE

FOR NAVY AIRCRAFT USE

SHIP TYPE	HULL NUMBER	YEAR	MONTH
B A P	5 2 8	2	8

SQDN TYPE	SQDN NUMBER	YEAR	MONTH
B A		2	8

I. REFERENCE INFORMATION

TYPE	NAME	DESIGNATION
1	USS WATERGIA	35528
COUNTRY	PROJECT	INSTITUTION
U.S.A.	W.A.P.	P.F.V.
U.R. NUMBER	OBSERVATION NUMBER	INSTRUMENT
3	5013	YET

III. RADIO MESSAGE INFORMATION

1	2	3	4	5	6
MESSAGE PREFIX	DATE (GMT)	TIME (GMT)	LATITUDE	LONGITUDE	INDICATOR GROUP
J J X X	1 7 0 8 2	1 5 3 0 7	7 4 2 1 5	6 4 4 4 3	8 8 8 8 8

II. OPTIONAL ENVIRONMENTAL INFORMATION

DEPTH 1	WIND	SEA LEVEL	AIR TEMP	AIR TEMP
10	DIR	2	3	4
1275	1 2 3	5 0 1 3	5 0 1 4	4 0 1 1
SEA TEMP	WAVE	SWELL	SOLAR	
1 8	2 0 4	3 1 7	2 4	1 5 3 0 4 0 2

1	2	3	4	5	6
DEPTH	TEMP	DEPTH	TEMP	DEPTH	TEMP
0 0 1 7 8	0 9 1 7 0	4 5 1 4 3	6 4 1 4 1	7 3 1 5 2	9 9 9 0 1

I. REFERENCE INFORMATION

STATION NUMBER	OBSERVATION NUMBER	INSTRUMENT

1	2	3	4	5	6
MESSAGE PREFIX	DATE (GMT)	TIME (GMT)	LATITUDE	LONGITUDE	INDICATOR GROUP
J J X X					8 8 8 8 8

II. OPTIONAL ENVIRONMENTAL INFORMATION

DEPTH 1	WIND	SEA LEVEL	AIR TEMP	AIR TEMP
10	DIR	2	3	4

1	2	3	4	5	6
DEPTH	TEMP	DEPTH	TEMP	DEPTH	TEMP
0 0					

I. REFERENCE INFORMATION

STATION NUMBER	OBSERVATION NUMBER	INSTRUMENT

1	2	3	4	5	6
MESSAGE PREFIX	DATE (GMT)	TIME (GMT)	LATITUDE	LONGITUDE	INDICATOR GROUP
J J X X					8 8 8 8 8

II. OPTIONAL ENVIRONMENTAL INFORMATION

DEPTH 1	WIND	SEA LEVEL	AIR TEMP	AIR TEMP
10	DIR	2	3	4

1	2	3	4	5	6
DEPTH	TEMP	DEPTH	TEMP	DEPTH	TEMP
0 0					

REMARKS

FIGURE C-2. SAMPLE BATHYTHERMOGRAPH LOG



APPENDIX B  
EXAMPLES OF XBT MALFUNCTIONS

Under normal usage, approximately 5 percent of XBT probes will malfunction for one or more reasons. Unfortunately, occasions arise when nearly all of a batch of XBT probes fail because of improper storage (high temperature, storage other than vertical) or old age (normal shelf life is 3 to 5 years). When failures occur, the analyst must recognize them in order to assure analysis accuracy. Higher than normal failure rate will be experienced in strong oceanic frontal zones, during heavy seas, and when the reporting ship is streaming instrumentation such as a VDS.

The following figures show a variety of XBT failures.\* Complete failures are relatively easy to detect. Marginal failures are frequently difficult to determine, particularly when taken in frontal areas. When in doubt, a second probe should be dropped as soon as possible to validate the trace in question.

---

\*A more comprehensive description of XBT failures is given in Kroner, S.M. and B.P. Blumenthal, Guide to common shipboard expendable bathythermograph (SXBT) recording malfunctions, Naval Oceanographic Office Reference Report 21, Bay St. Louis, MS. (In preparation).

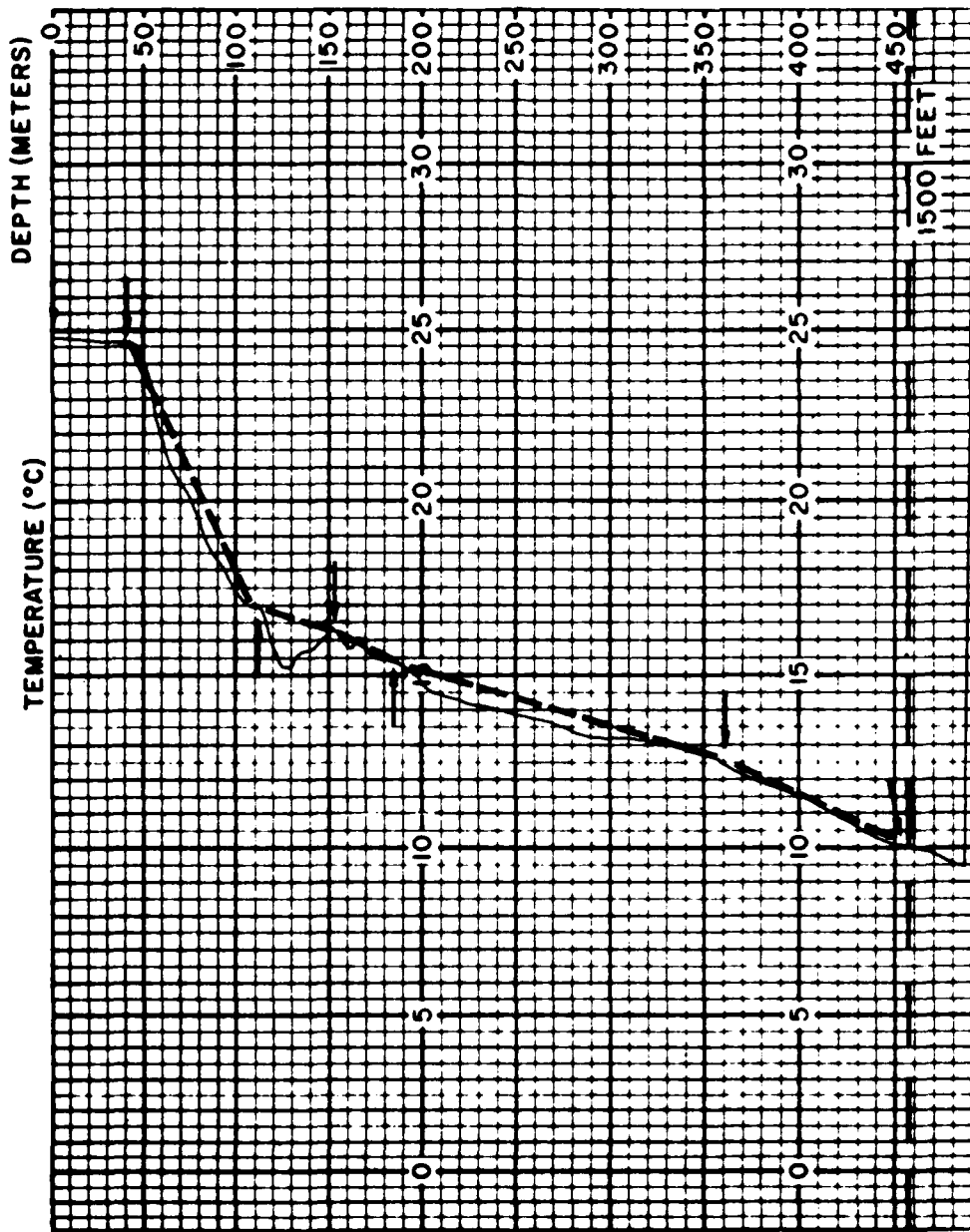

Figure 1. Encoded XBT trace (dashed line) compared with the observed trace (solid line). Depth temperature pairs of encoded trace indicated by arrow. Note that failure of encoded trace to define sound channel (axial depth 127 m) would cause erroneous sonar range predictions.

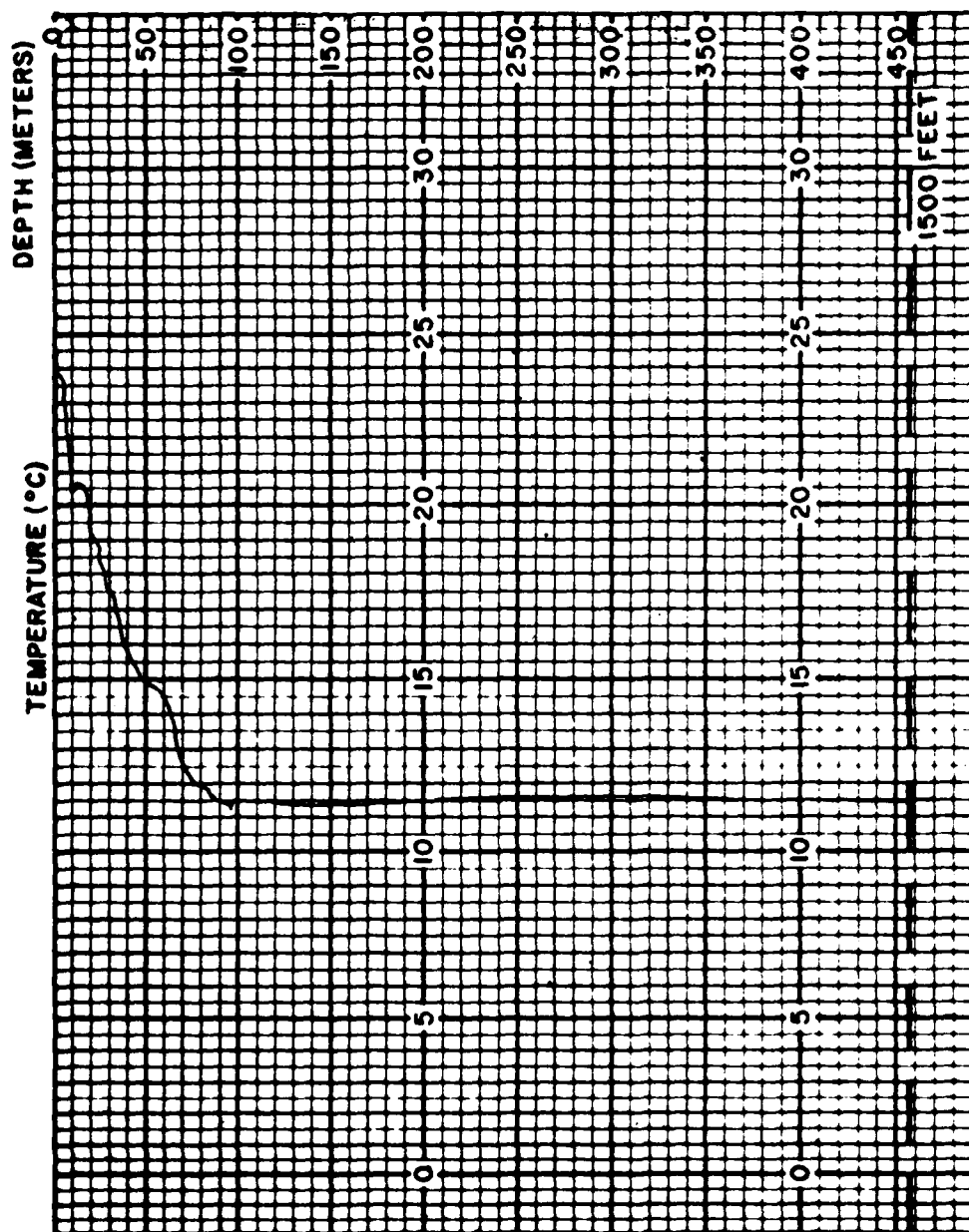

Figure 2. XBT trace taken in shallow water. Horizontal tick mark at 98 m is characteristic of probe striking bottom.

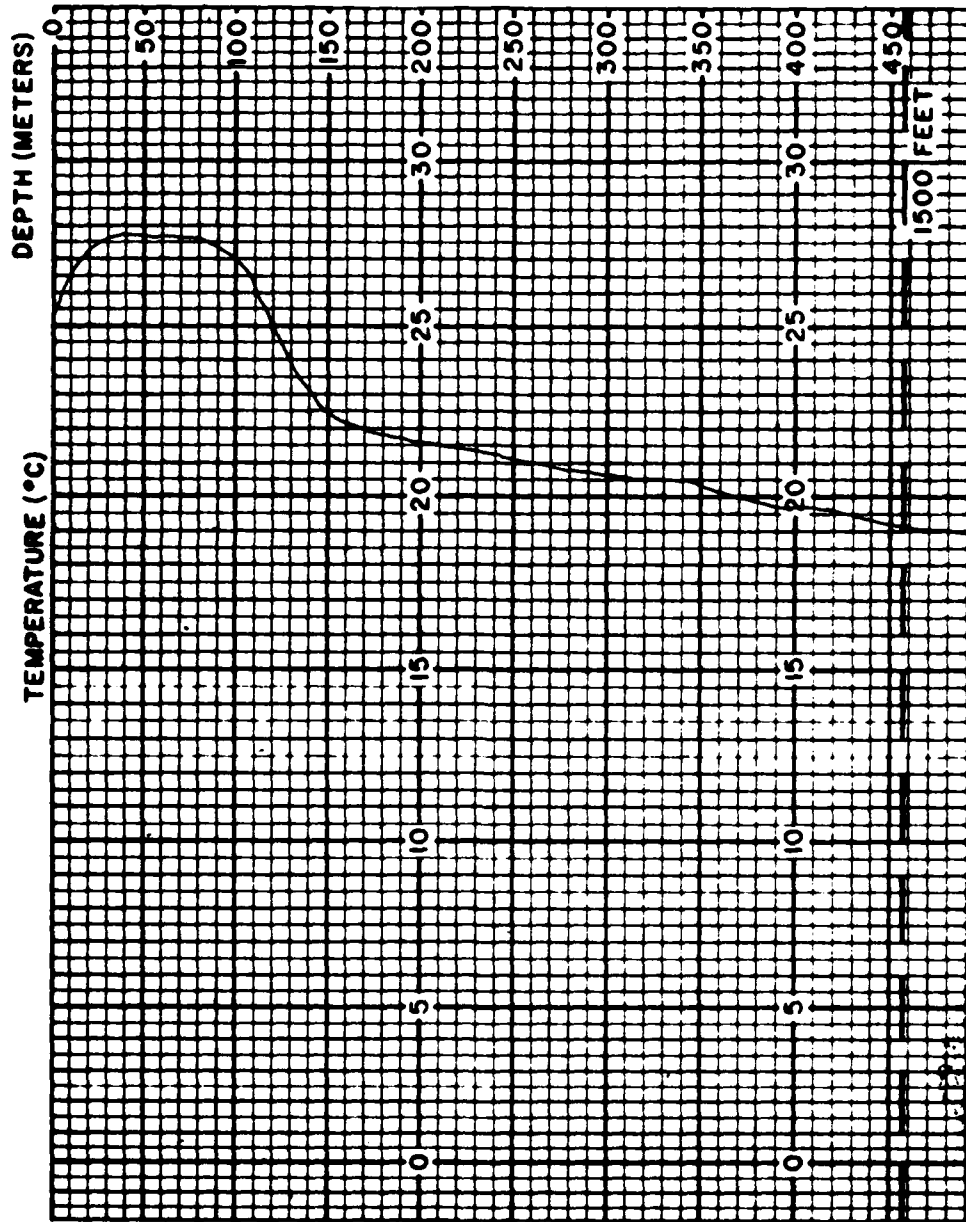

Figure 3. Wire stretch occurred at the surface, thus preventing accurate determination of SST and SLD. Temperature at depth is lower than that shown on trace.

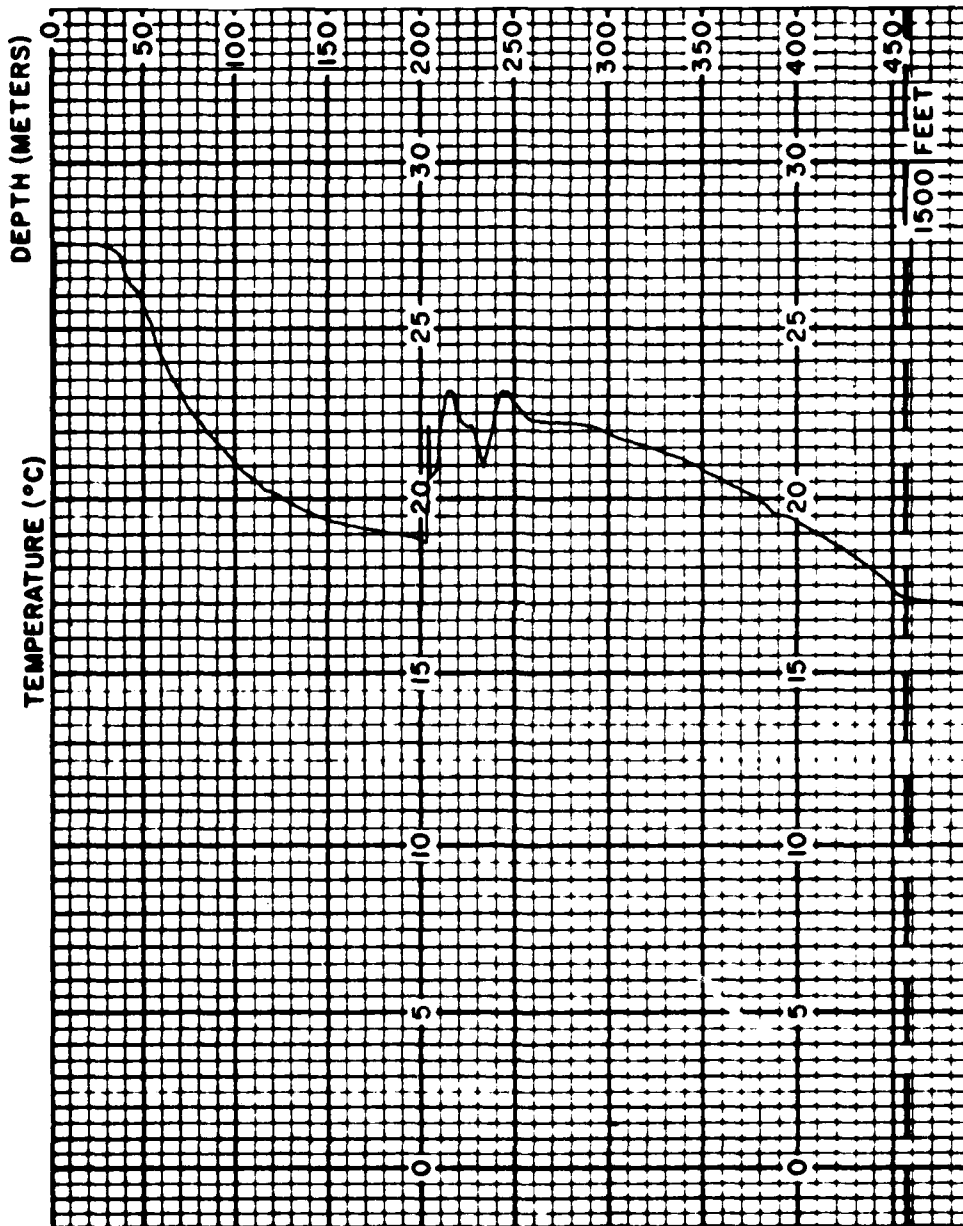

Figure 4. Rapid jump of sea to right at a depth of 203 m is probably the result of loose wire connection or damaged insulation.

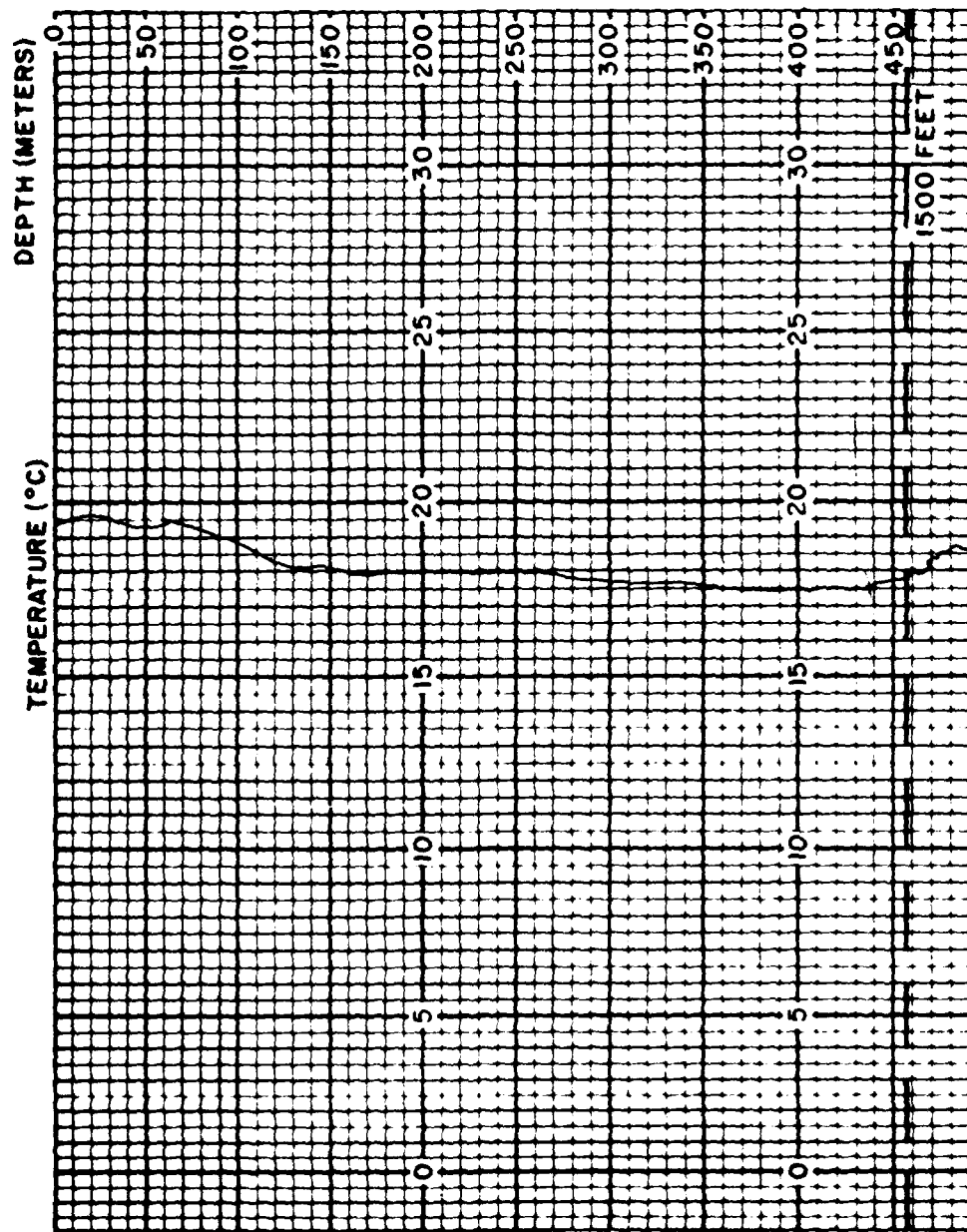

Figure 5. Apparent temperature increase at 437 m is not real and is the result of wire stretch.

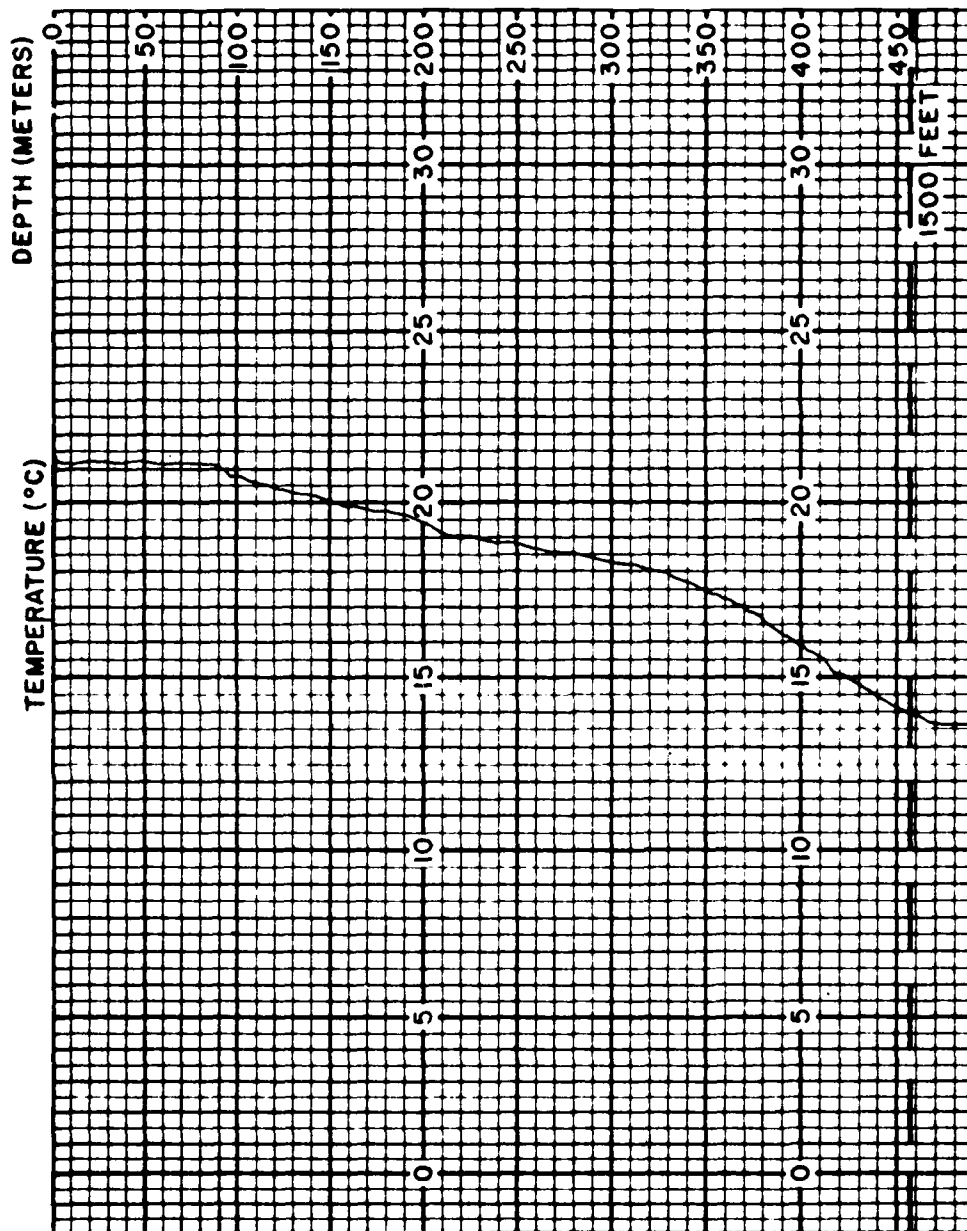

Figure 6. Normal XBT trace on the Sargasso Sea.

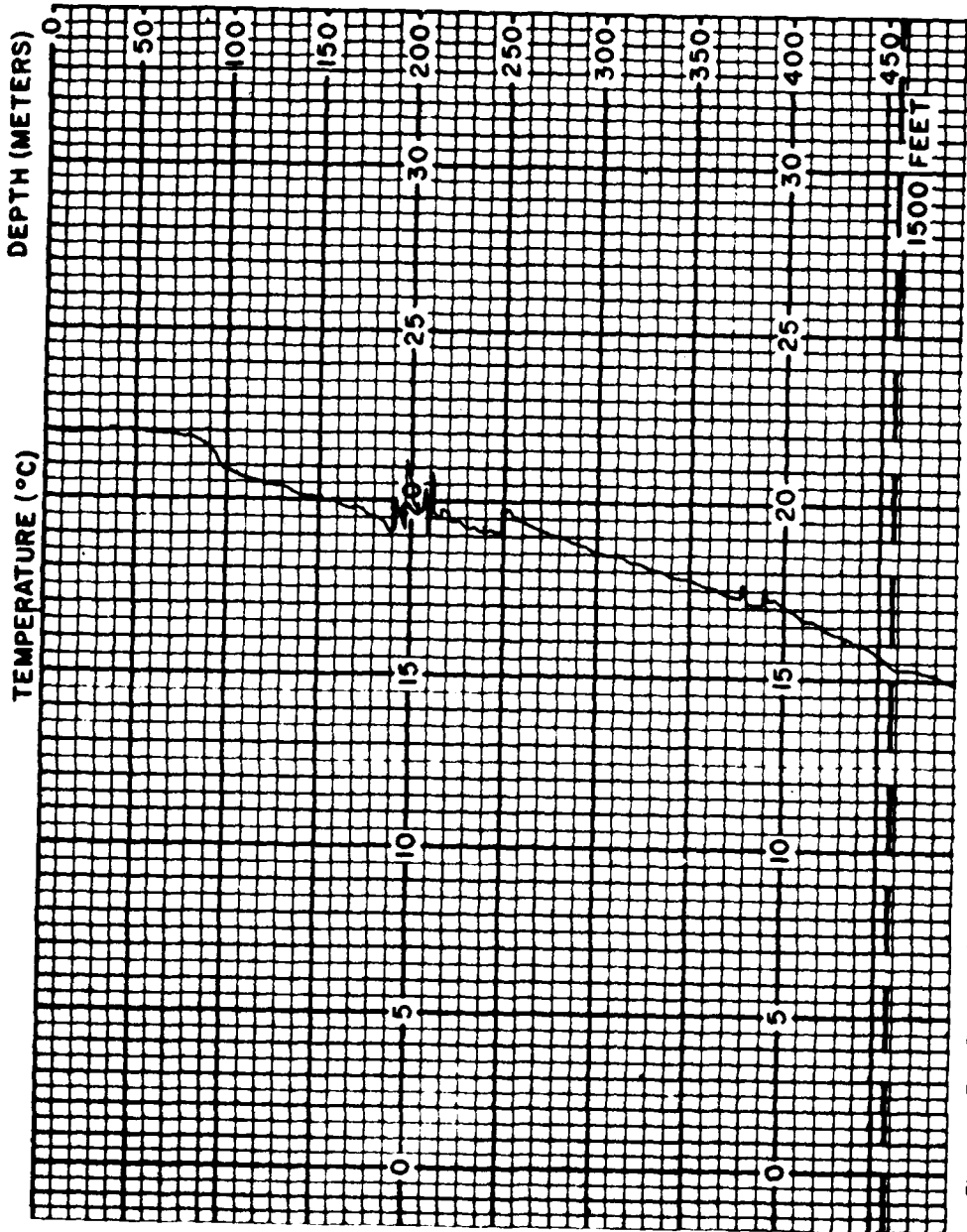

Figure 7. Trace taken near that in Figure 6 but with apparent leakage in wire insulation. Data below 190 m is unusable.

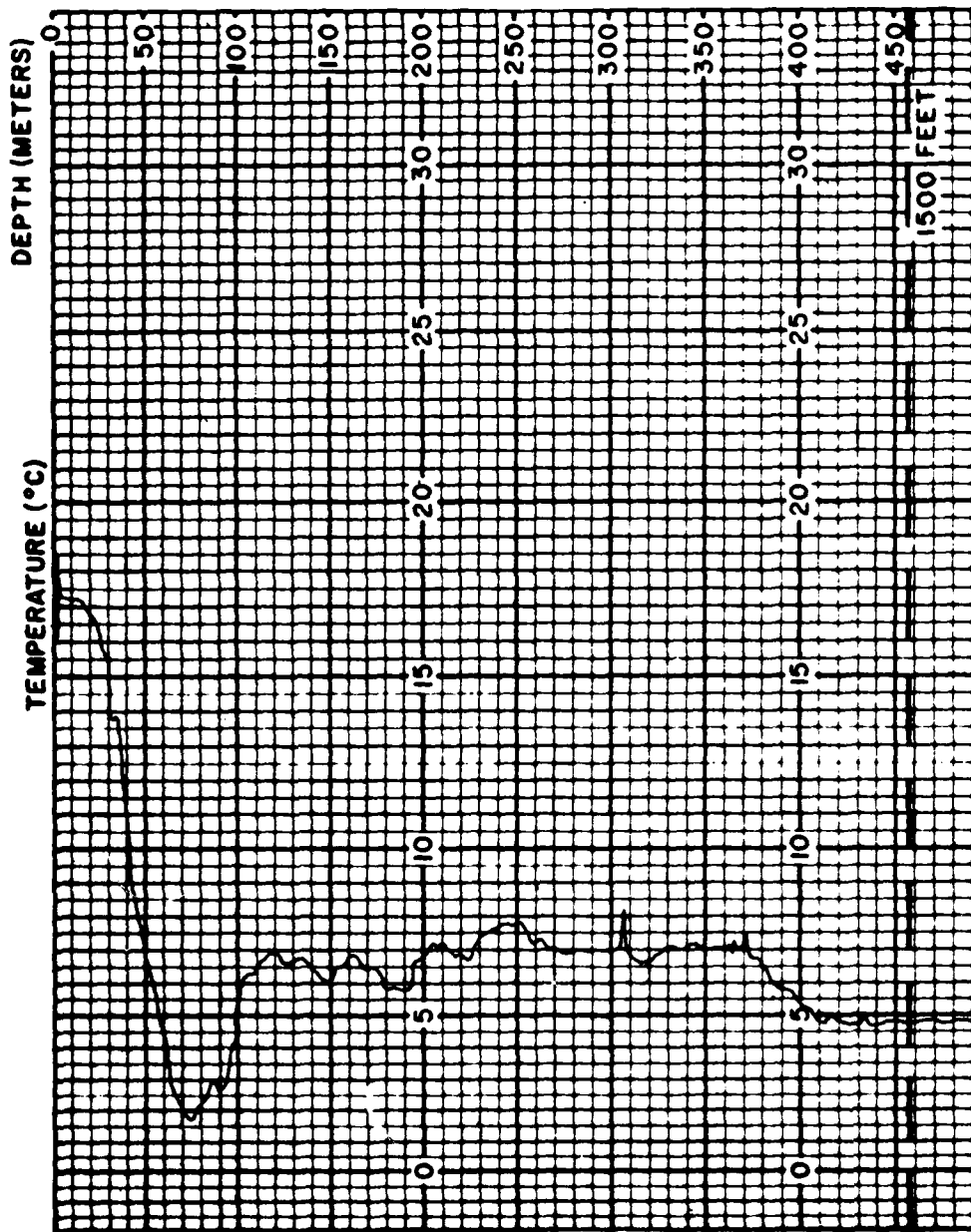

Figure 8. XBT trace taken in the North Polar Front showing the difficulty in distinguishing oceanic variability (below 100 m) from wire leakage (above 310 m).

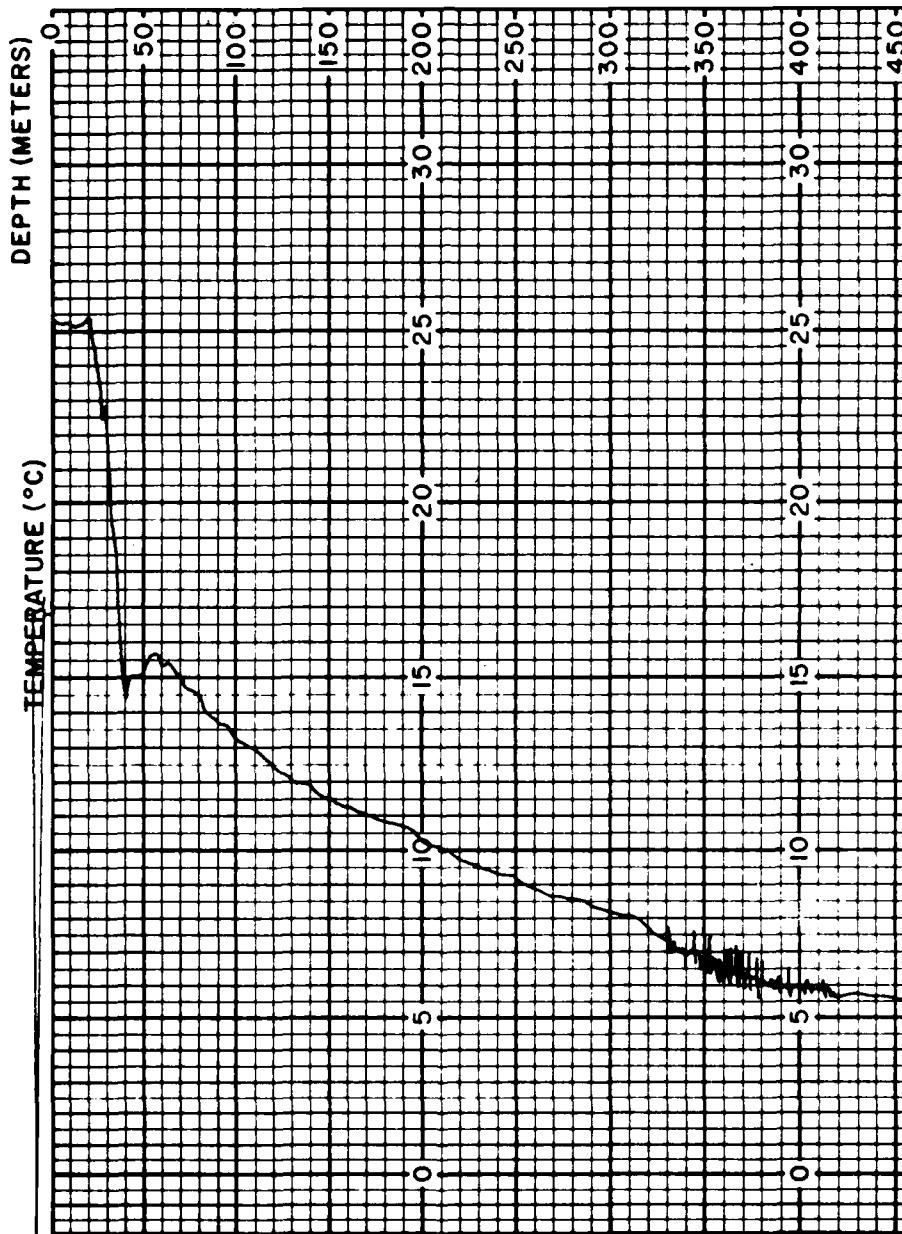

Figure 9. Noise between 330 and 420 m caused by outside electromagnetic interference. Trace can be read through the noise.

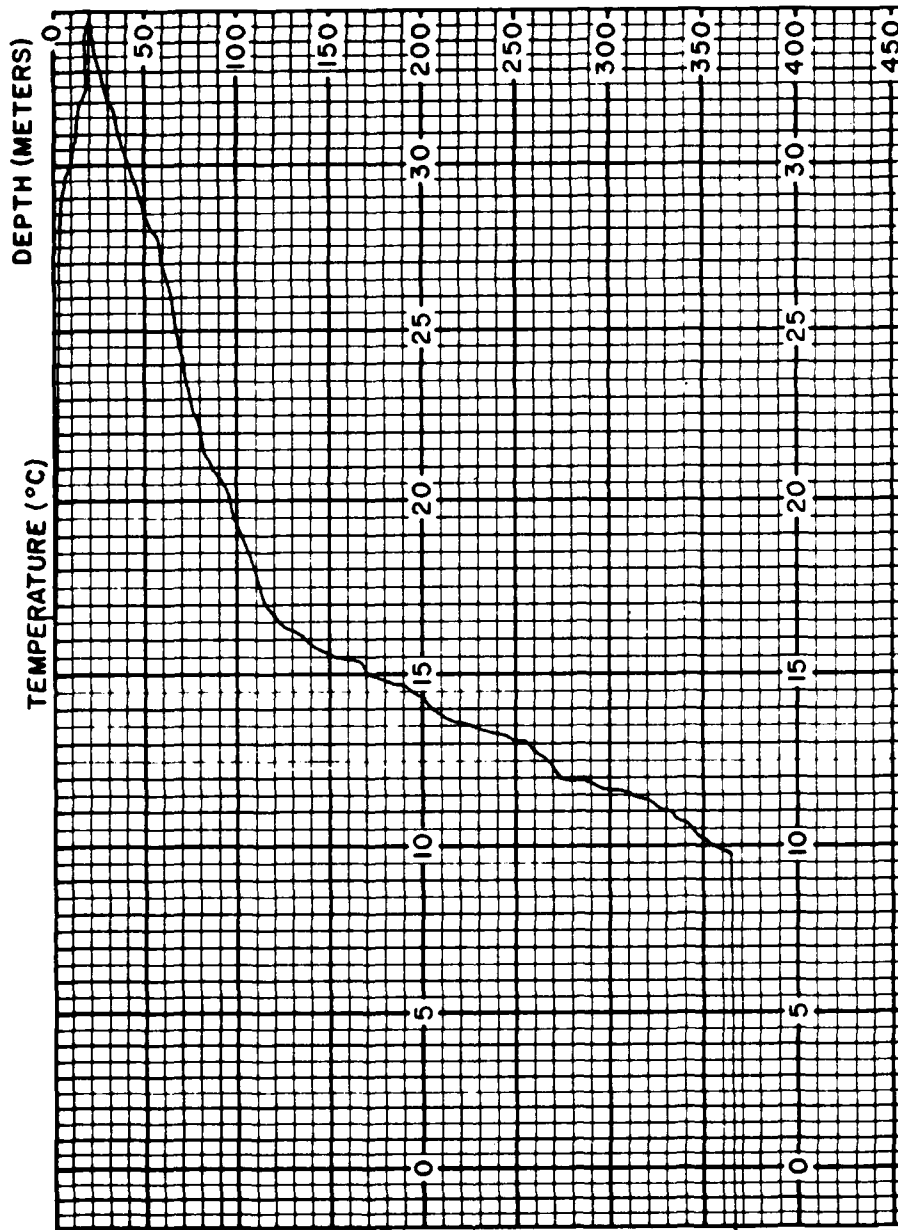

Figure 10. Excursion of pen to right side of recorder chart is probably caused by a bad wire connection between recorder and launcher. Temperature values are high over entire depth range of the trace.

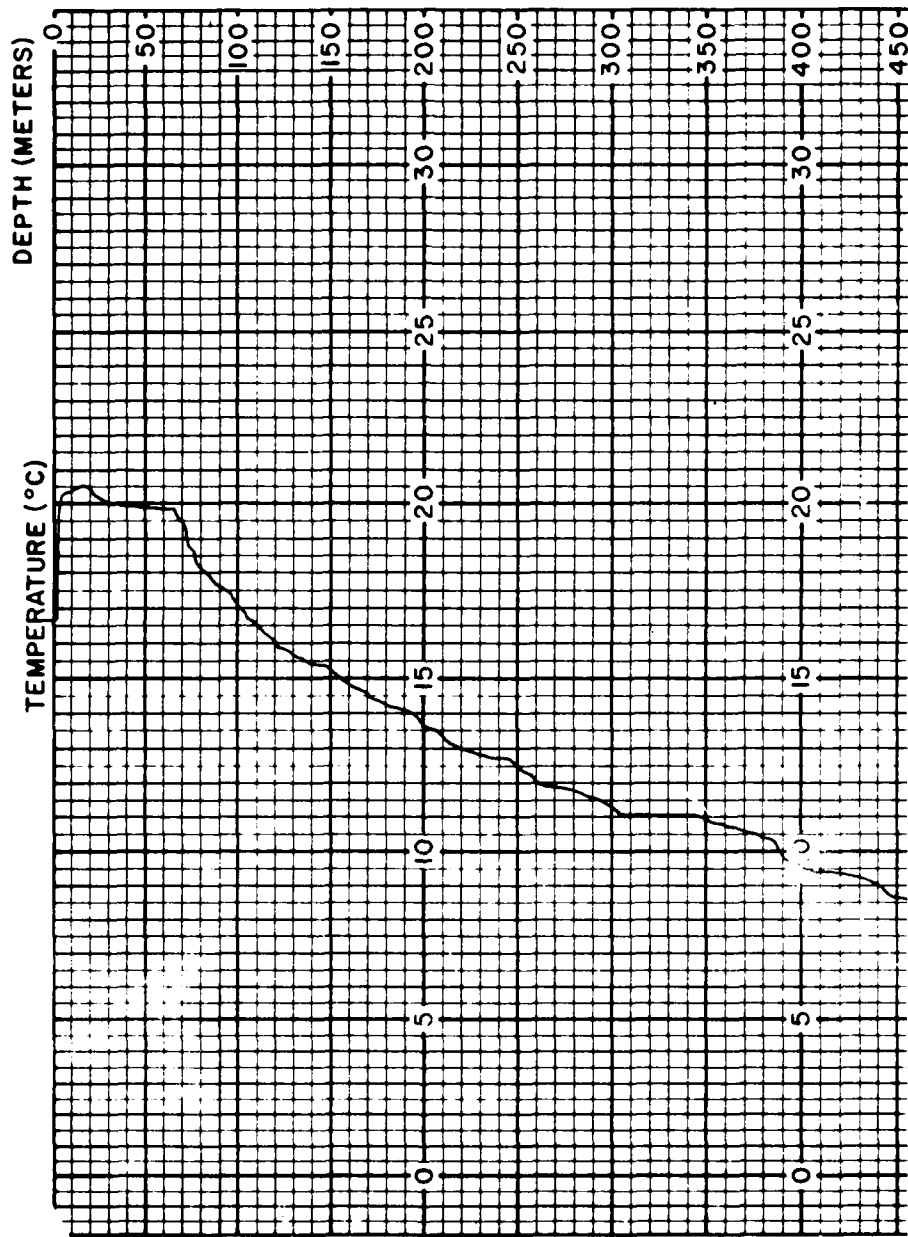

Figure 11. Trace is typical to 304 m where the recorder potentiometer apparently stuck. Data below 345 m cannot be corrected. Note the presence of the calibration tick indicated by the vertical line above the surface at 16.7°C (62.1°F). SST is difficult to read because of movement of the chart paper during the time it takes the pen to move from the calibration point to the temperature value at the surface.

APPENDIX C  
WATER MASS CRITERIA  
NORTH ATLANTIC OCEAN/MEDITERRANEAN SEA

This appendix presents area definition and the thermal characteristics of each water mass within the file for the North Atlantic Ocean and the Mediterranean Sea. Subsequent appendixes cover the North Pacific and the Indian Oceans. Each segment is divided into areas designated by letter (e.g., Atlantic A). Within each segment, geographic regions of similar oceanic properties are designated by number (Atlantic All). Although as many as five water masses may occur in each region, most regions normally contain one or two. For example, region All includes three water masses: Southern Slope, Stream, and Sargasso. It should be noted that large water masses, such as the Sargasso Sea, may cover several regions. Regions, water mass names, temperature range at 200 m (temperature filter), temperature difference between 200 and 300 m (DT) where applicable, file position in the ICAPS water mass file, and frequency of observation of each water mass are provided in tabular form for each segment.

Water mass classification should be made initially using temperature at the 200 m level. When two water masses have similar temperature characteristics at this level, the temperature difference between 200 and 300 m (DT) should be used as a tie breaker.

CONTENTS

	Page
Locator Chart . . . . .	49
Atlantic Area A . . . . .	50
Atlantic Area B . . . . .	52
Atlantic Area C . . . . .	54
Atlantic Area D . . . . .	56
Atlantic Area E . . . . .	58
Mediterranean Sea . . . . .	60



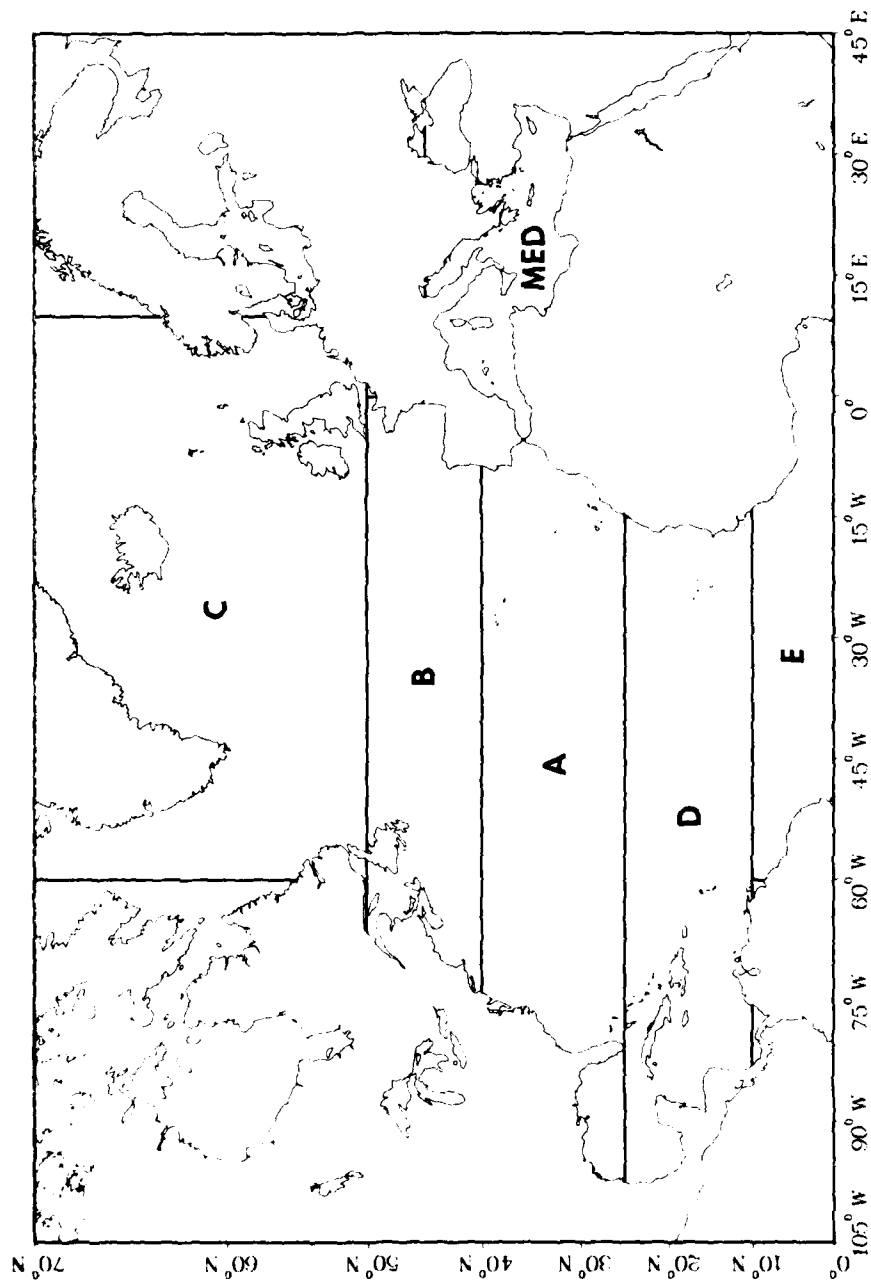

## ATLANTIC AREA A

Region	Water Mass Name	T200 (°C)		DT (°C)		Position	Freq. (%)	Region	Water Mass Name	T200 (°C)		DT (°C)		Position	Freq. (%)
		Min	Max	Min	Max					Min	Max	Min	Max		
A1	W. GULF W. LOOP	10 15	15 25			1 2	46 54	A14	Atlantic Central	13	25			1	100
A2	E. GULF E. LOOP	10 15	15 25			1 2	39 61	A15 A16	N.E. LANT N.E. LANT	12 12	20 18			1 1	100 100
A3	SO. SLOPE COLD WALL FLORIDA CURRENT SARGASSO	9 15 17 15	15 25 25 25			1 2 3 4	8 15 59 18	A17 A18	N.E. LANT S.W. GIBRALTAR	12 12	18 20			1 1	100 100
A4	G. ANTILLES SARGASSO	15 15	26 25	-8.0 -1.6	0.0	1 2	77 23	A19 A20	S.E. GIBRALTAR SCOTIAN SLOPE STREAM SARGASSO	12 6 9 15 15	20 9 15 25 25			1 1 2 3 4	100 1 58 13 28
A5	G. ANTILLES	15	25			1	100	A21	SLOPE STREAM SARGASSO	9 15 15	15 25 25	-8.0 -1.6 0.0		1 2 3	13 8 79
A6	ANTILLES C. SARGASSO	15 15	25 25	-8.0 -1.6	0.0	1 2	24 76	A22	TRANSITTON DRIFT ATLANTIC CENTRAL	8 13 13	13 25 25	-8.0 -1.6 6.0		1 2 3	1 3 96
A7	ANTILLES C. SARGASSO	15 15	22 22	-8.0 -1.6	0.0	1 2	8 92	A23	N.E. LANT	10	18			1	100
A8	ATLANTIC CENTRAL	15	22			1	100	A24	N.E. LANT	12	18			1	100
A9	S.E. LANT	13	20			1	100	A25	N.E. LANT	12	18			1	100
A10	S.E. LANT	12	18			1	100	A26	N.W. GIBRALTAR	10	18			1	100
A11	SO. SLOPE STREAM SARGASSO	9 15 15	15 25 25	-8.0 -1.6	0.0	1 2 3	8 29 61	A27	N.E. GIBRALTAR	10	18			1	100
A12	STREAM SARGASSO	15 15	25 25	-8.0 -1.6	0.0	1 2	2 98	A28	ATLANTIC GIBRALTAR	11 11	15 15	-6.0 -0.2	0.0	1 2	11 89

ATLANTIC AREA A

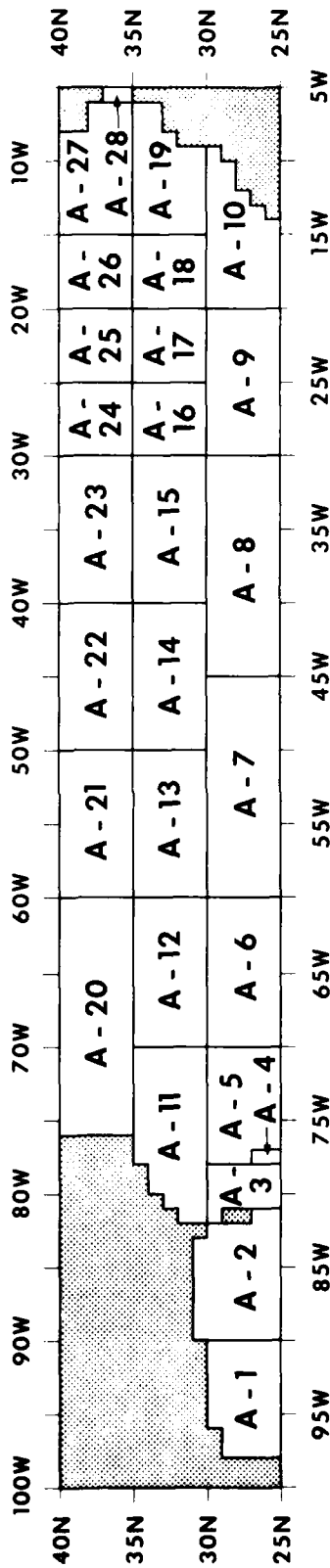

## ATLANTIC AREA B

Region	Water Mass Name	T200 (°C)			DI (°C)			Freq. (%)	Position	Region	Water Mass Name	T200 (°C)			DI (°C)			Freq. (%)	Position
		Min	Max	Max	Min	Max	Max					Min	Max	Max	Min	Max	Max		
B1	SCOTTIAN SLOPE	6	9	15	9	15	25	9	1	B8	N.E. ATLANTIC	9	15	15	9	15	25	9	1
	STREAM	15	25	-8.0	9	9	9	76	2	B9	LAURENTIAN GRAND BANKS	-2	6	6	6	6	9	9	2
	SARGASSO	15	25	-1.6	0.0	0.0	0.0	6	4			6	9	9	6	9	9	2	
B2	MODIFIED LAURENTIAN SLOPE	3	6	9	6	9	9	9	1	B10	LABRADOR DAVIS STRAIT TRANSITION	-2	3	3	3	3	8	8	1
	SCOTTIAN SLOPE	6	9	9	9	9	9	28	2		DAVIS STRAIT TRANSITION	3	8	8	8	12	12	2	
	SCOTTIAN SLOPE	9	15	15	15	15	15	63	3		DRIIFT	8	12	12	20	20	20	4	
B3	LAURENTIAN GRAND BANKS SLOPE	-2	6	9	6	9	9	11	1	B11	TRANSITION DRIIFT	5	11	11	11	18	18	18	2
	STREAM	9	15	15	15	15	15	50	3		N.E. ATLANTIC	11	18	18	18	18	18	79	
	LABRADOR MIXED TRANSITION DRIIFT	15	25	25	25	25	25	27	4	B12	N.E. ATLANTIC	10	18	18	18	18	18	18	1
B4	LABRADOR MIXED TRANSITION DRIIFT	3	9	13	9	13	13	24	1	B13	N.E. ATLANTIC	9	15	15	9	15	15	15	1
	STREAM	9	15	15	15	15	15	10	2		BISCAY	9	15	15	9	15	15	15	
	LABRADOR MIXED TRANSITION DRIIFT	13	25	25	25	25	25	66	3	B14	LABRADOR DAVIS STRAIT	9	15	15	9	15	15	15	1
B5	DRIIFT	11	14	20	11	14	20	48	1	B15	LABRADOR DAVIS STRAIT	-2	3	3	3	12	12	12	2
	N.E. ATLANTIC	14	20	20	20	20	20	52	2		LABRADOR DAVIS STRAIT	-2	3	3	3	12	12	12	
B6	N.E. ATLANTIC	11	18	18	11	18	18	100	1	B16	LABRADOR DAVIS STRAIT TRANSITION	-2	3	3	3	7	7	7	1
	N.E. ATLANTIC	11	18	18	11	18	18	100	1		LABRADOR DAVIS STRAIT TRANSITION	-2	3	3	3	7	7	7	2
B7	N.E. ATLANTIC	9	15	15	9	15	15	100	1		LABRADOR DAVIS STRAIT TRANSITION	7	15	15	7	15	15	15	3
	N.E. ATLANTIC	9	15	15	9	15	15	100	1		LABRADOR DAVIS STRAIT TRANSITION	7	15	15	7	15	15	15	4

### ATLANTIC AREA B

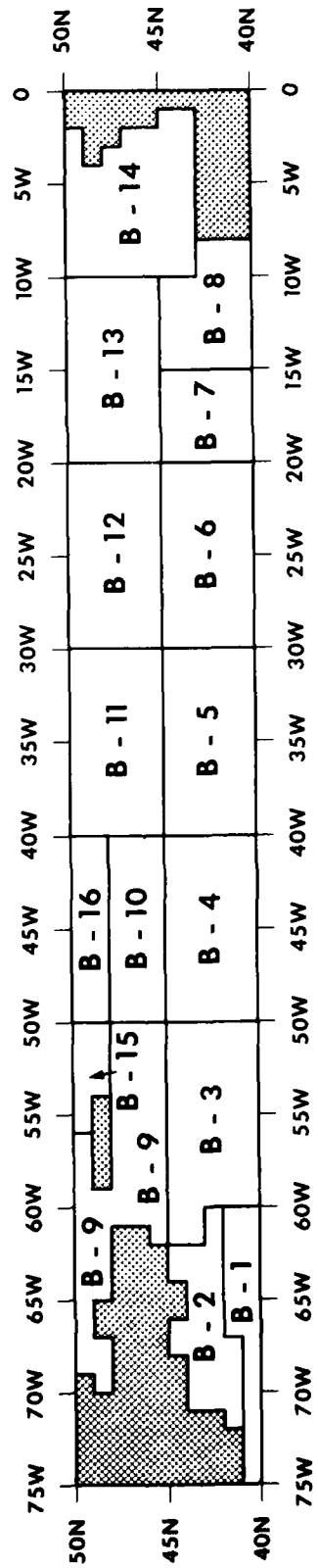

## ATLANTIC AREA C

Region	Water Mass Name	T200 (°C)		DT (°C)		Position	Freq. (%)
		Min	Max	Min	Max		
C1	LAURENTIAN GRAND BANKS	-2	6			1	77
		6	9			2	23
C2	LABRADOR DAVIS STRAIT	-2	3			1	14
		3	12			2	86
C3	LABRADOR DAVIS STRAIT TRANSITION	-2	3			1	7
		3	7			2	82
C4	EAST GREENLAND IRMPINGER	3	15			3	31
		-2	5			1	19
C5	IRMPINGER NORTHEAST ATLANTIC	5	17			2	81
		3	9			1	35
C6	NORTHEAST ATLANTIC	9	15			2	65
		4	17			1	100
C7	NORTHEAST ATLANTIC	4	17			1	100
		4	17			1	100
C8	BALLIN OUTFLOW	4	17			1	100
		4	17			1	100
C9	LABRADOR DAVIS STRAIT	-2	1			1	56
		1	1			2	44
C10	WEST GREENLAND DAVIS STRAIT	-2	3			1	31
		3	12			2	69
C11	EAST GREENLAND IRMPINGER	-2	5			1	32
		5	12			2	68
C12	MIXED WEST ICELANDIC IRMPINGER	-2	5	-8.0	-1.2	1	19
		-2	5	-1.2	3.0	2	5
C13	POLAR FRONT EAST ICELANDIC NORTH ATLANTIC	5	12			1	76
		-2	5	-8.0	-1.2	1	9
C14	POLAR FRONT EAST ICELANDIC NORWEGIAN SEA	-2	5	-1.2	3.0	2	39
		5	12			3	52
C15	POLAR FRONT EAST ICELANDIC NORWEGIAN SEA	-2	5	-8.0	-1.2	1	10
		-2	5	-1.2	3.0	2	37
C16	POLAR FRONT EAST ICELANDIC NORWEGIAN SEA	5	12			3	53
		-2	5	-8.0	-1.2	1	10
C17	POLAR FRONT EAST ICELANDIC NORWEGIAN SEA	-2	5	-1.2	3.0	2	11
		5	12			3	79

# ATLANTIC AREA C

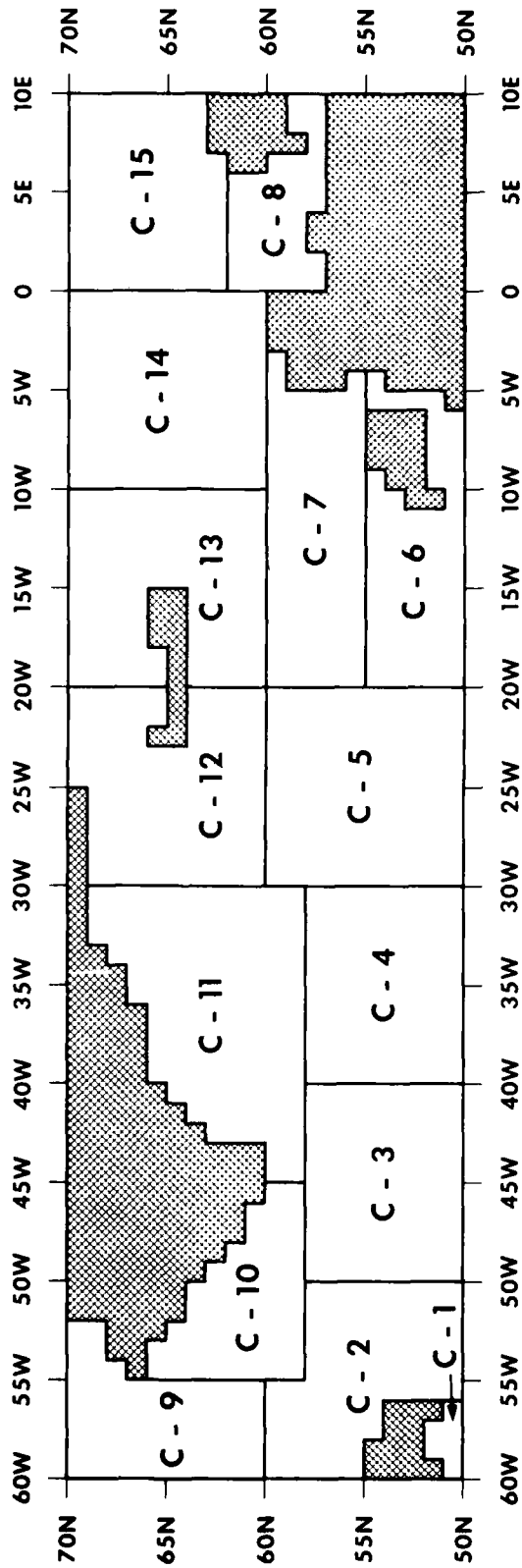

## ATLANTIC AREA D

Region	Water Mass Name	T200 (°C)		DT (°C)		Position	Freq. (Z)	Region	Water Mass Name	T200 (°C)		DT (°C)		Position	Freq. (Z)
		Min	Max	Min	Max					Min	Max	Min	Max		
D1	COLOMBIAN WEST CARIBBEAN	10.0	20.0			1	84	D12	EAST GULF	10.0	15.0			1	23
		20.0	30.0			2	16		EAST LOOP	15.0	25.0			2	77
D2	VENEZUELAN	10.0	20.0			1	100	D13	SOUTH SLOPE	9.0	15.0			1	2
									COLD WALL	15.0	17.0			2	4
D3	N.E. BRAZIL ANTILLES MIXED ANTILLES	9.0	13.0			1	8		FLORIDA CURRENT	17.0	25.0	-8.0	-1.6	3	90
		13.0	17.0			2	35		SARGASSO	17.0	25.0	-1.6	0.0	4	4
		17.0	21.0			3	57	D14	GREATER ANTILLES	15.0	25.0			1	100
D4	TROPOLANT ATLANTIC CENTRAL	9.0	15.0			1	58	D15	ANTILLES CURRENT	15.0	25.0	-8.0	-1.6	1	77
		15.0	25.0			2	42		SARGASSO	15.0	25.0	-1.6	0.0	2	23
D5	S.E. ATLANTIC	10.0	18.0			1	100	D16	ANTILLES CURRENT	15.0	25.0	-8.0	-1.6	1	88
D6	S.E. ATLANTIC	10.0	16.0			1	100		SARGASSO	15.0	25.0	-1.6	0.0	2	12
D7	COLOMBIAN WEST CARIBBEAN	10.0	20.0			1	41	D17	ANTILLES CURRENT	15.0	22.0	-8.0	-1.6	1	24
		20.0	30.0			2	59		SARGASSO	15.0	22.0	-1.6	0.0	2	76
D8	CARIBBEAN COOL CENTRAL CARIBBEAN	10.0	20.0			1	27	D18	ATLANTIC CENTRAL	15.0	22.0			1	100
		20.0	30.0			2	73	D19	S.E. ATLANTIC	13.0	20.0			1	100
D9	CARIBBEAN COOL EAST CARIBBEAN	10.0	20.0			1	71	D20	S.E. ATLANTIC	10.0	18.0			1	100
		20.0	30.0			2	29								
D10	S.E. ATLANTIC	10.0	16.0			1	100								
D11	CAMPECHE WEST LOOP	10.0	15.0			1	34								
		15.0	25.0			2	66								

### ATLANTIC AREA D

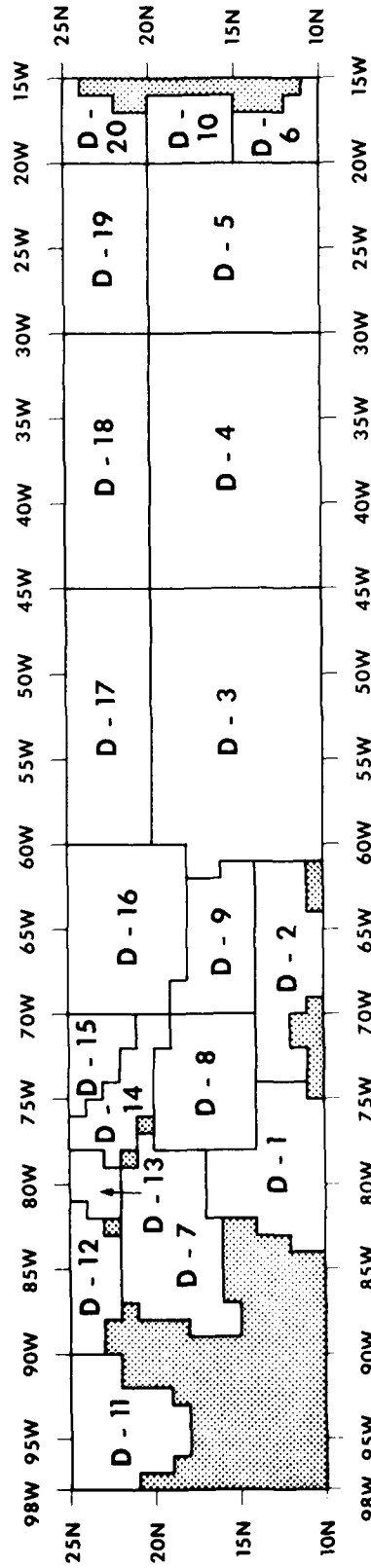

### ATLANTIC AREA E

Region	Water Mass Name	T200 (°C)		DT (°C)		Position	Freq. (%)
		Min	Max	Min	Max		
E1	TROPICAL	8.0	14.0			1	65
	EQUALANT	14.0	22.0			2	35
E2	TROPICAL	8.0	16.0			1	100
E3	S.E. ATLANTIC	10.0	16.0			1	100
E4	S.E. ATLANTIC	10.0	16.0			1	100
E5	S.E. ATLANTIC	11.0	19.0			1	100
E6	GULF OF GUINEA	11.0	19.0			1	100
E7	TROPICAL	8.0	14.0			1	100
E8	TROPICAL	8.0	14.0			1	96
	EQUALANT	14.0	22.0			2	4
E9	TROPICAL	8.0	14.0			1	100

# ATLANTIC AREA E

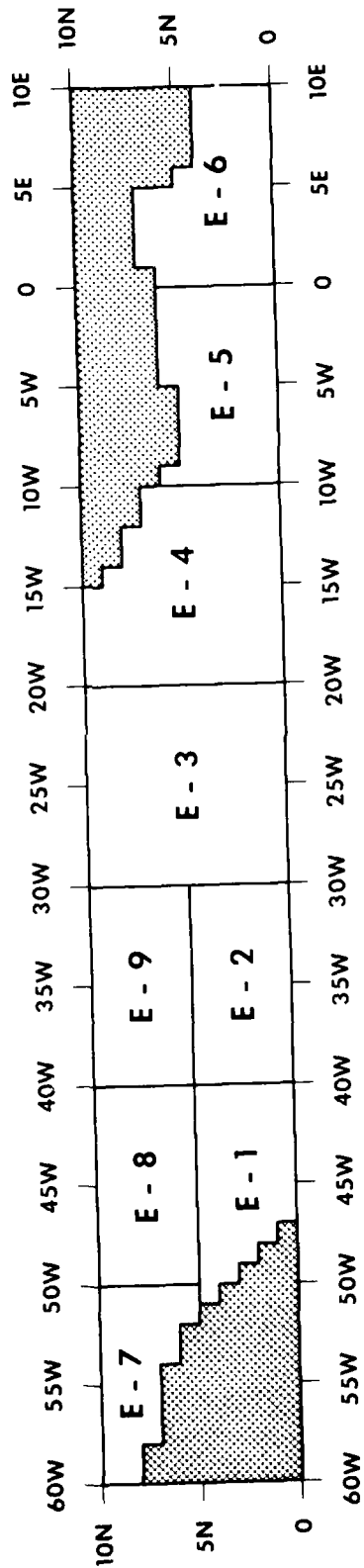

## MEDITERRANEAN

Region	Water Mass Name	T200 (‰)		S2 (‰)		Mix	Position	Freq. (%)
		Min	Max	Min	Max			
M1	ATLANTIC GIBRALTAR	11	15	-6.0	-0.2		1	11
		11	15	-0.2	0.1		2	89
M2	ATLANTIC ALGERIAN	11	15	-6.0	-0.2		1	13
		11	15	-0.2	0.1		2	87
M3	MALTIAN	13	18				1	100
M4	LIBYAN	13	18				1	100
M5	IONIAN	13	18				1	100
M6	EAST IONIAN	13	20				1	100
M7	MELIORAN	13	15				1	100
M8	TYRRHENIAN	12	15				1	100
M9	SOUTH AEGEAN	12	18				1	100
M10	NORTH AEGEAN	11	17				1	100
M11	IGURIAN	11	16				1	100
M12	ADRIATIC	12	16				1	100
M13	MARMARA	12	16				1	100
M14	BLACK SEA	6	10				1	100

# MEDITERRANEAN

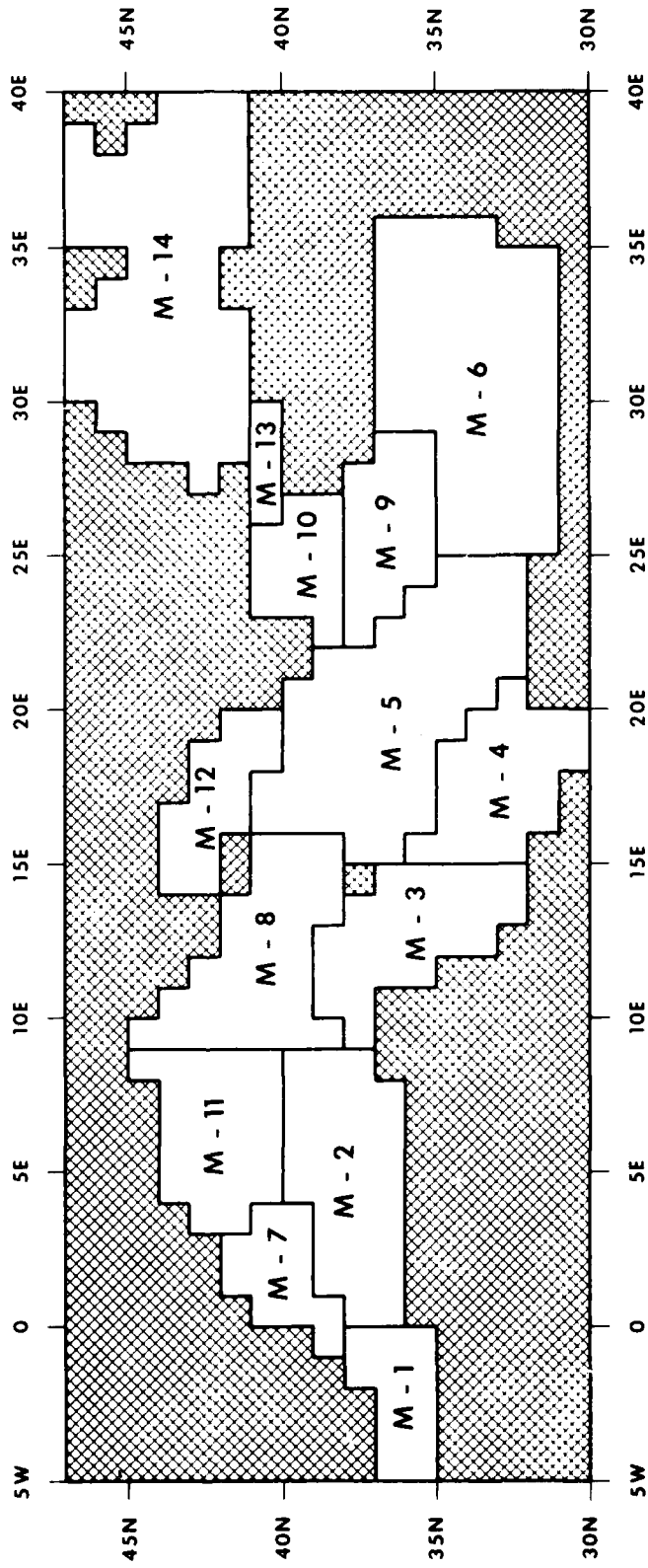



APPENDIX D  
WATER MASS CRITERIA  
NORTH PACIFIC OCEAN  
(See Appendix C for explanation)

CONTENTS

	Page
Locator Chart . . . . .	65
Pacific Area A . . . . .	66
Pacific Area B . . . . .	68
Pacific Area C . . . . .	70
Pacific Area D . . . . .	72
Pacific Area E . . . . .	74
Pacific Area F . . . . .	76
Pacific Area G . . . . .	78



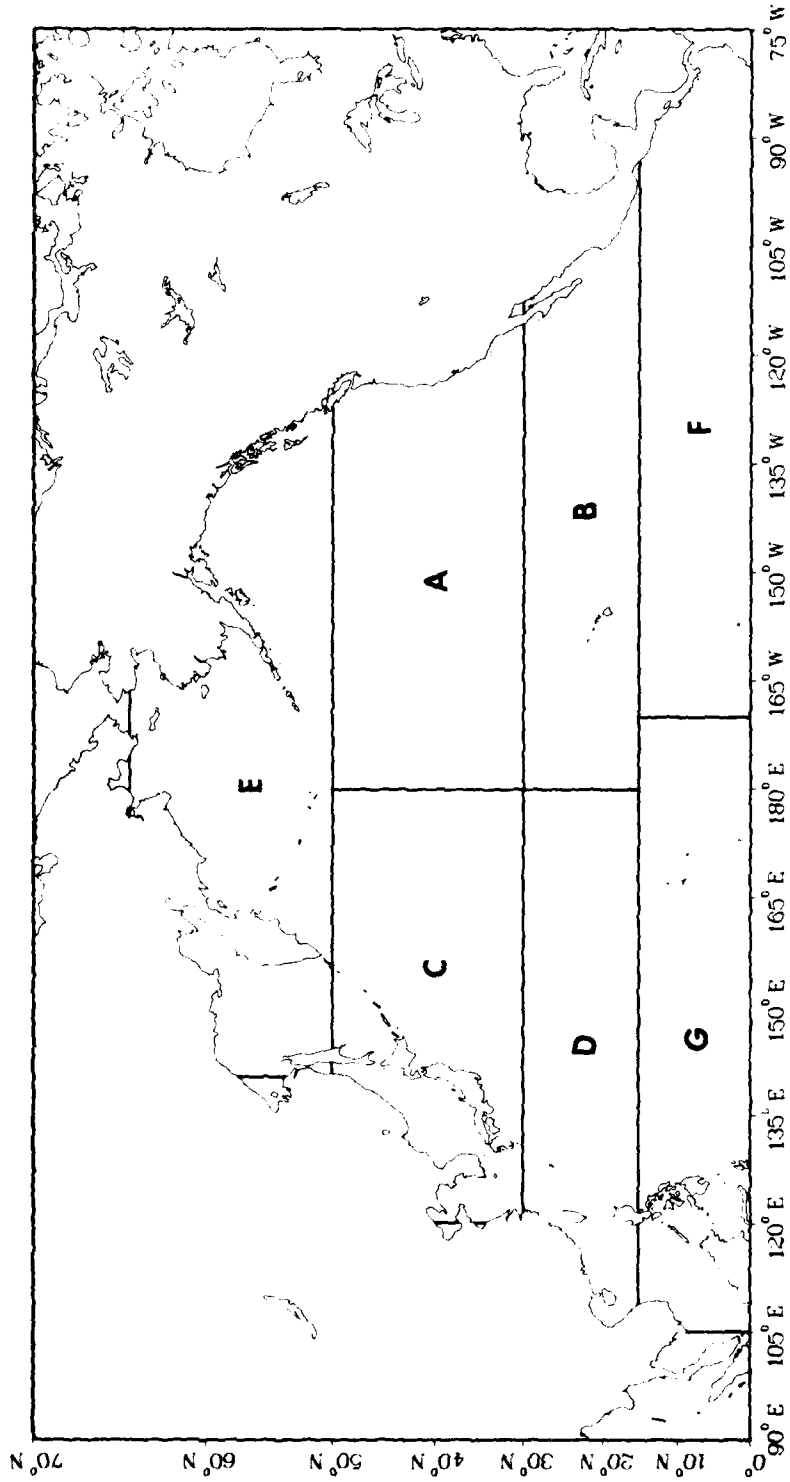

## PACIFIC AREA A

Region	Water Mass Name	T200 (°C)		DF (°C)		Position	Freq. (%)
		Min	Max	Min	Max		
A1	TRANSITION	7	13			1	35
	KUROSHIO	13	19			2	65
A2	EAST TRANSITION	10	16			1	100
A3	NORPAC	7	12			1	43
	EAST TRANSITION	12	16			2	57
A4	CALIFORNIAN	5	11			1	60
	EAST TRANSITION	11	19			2	40
A5	CALIFORNIAN	5	11			1	100
A6	GULF OF CALIFORNIA	10	18			1	100
A7	ALEUTIAN	0	7			1	8
	NORPAC	7	12			2	92
A8	ALASKAN	0	7			1	46
	NORPAC	7	12			2	54
A9	ALASKAN	0	9			1	100
A10	ALEUTIAN	0	6			1	100

# PACIFIC AREA A

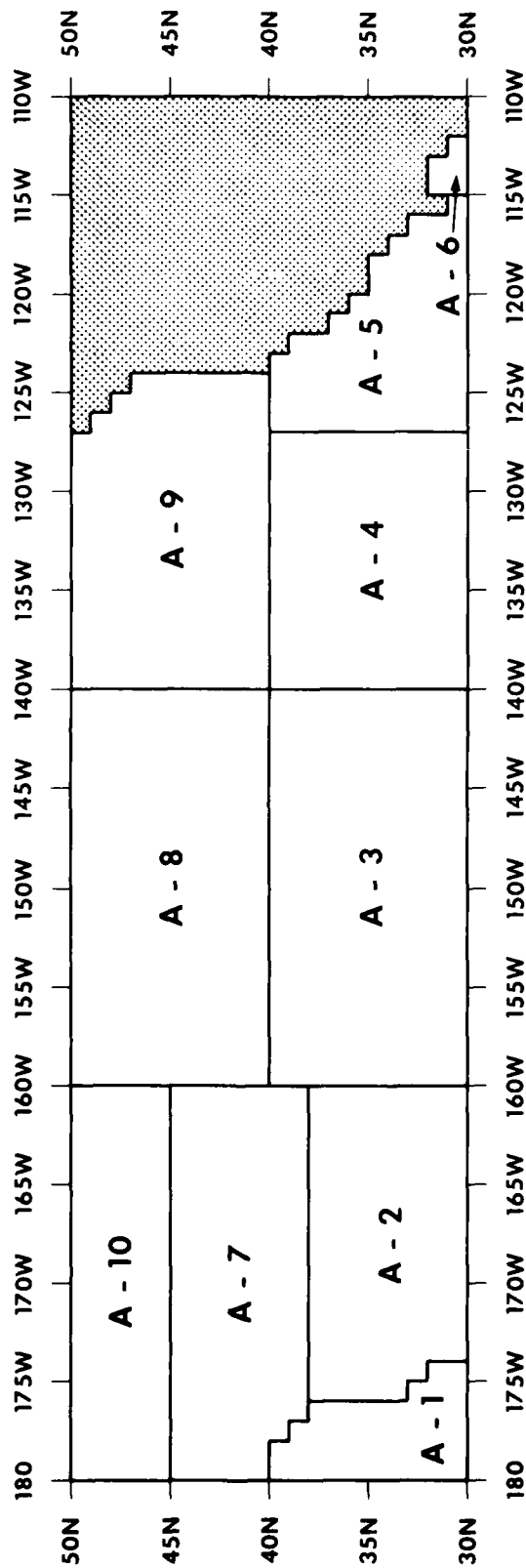

## PACIFIC AREA B

Region	Water Mass Name	T200 (°C)		DT (°C)		Position	Freq. (%)
		Min	Max	Min	Max		
B1	MARSHALLS CENTRAL	8	17			1	30
		17	26			2	70
B2	N. EQUAPAC E. CENTRAL	9	14			1	1
		14	21			2	99
B3	N. EQUAPAC E. CENTRAL	8	14			1	22
		14	20			2	78
B4	N.E. EQUAPAC E. CENTRAL S.E. HAWAIIAN	8	12			1	8
		12	16			2	52
		16	24			3	40
B5	N.E. EQUAPAC	8	15			1	100
B6	N.E. EQUAPAC GULF OUTFLOW	9	14			1	93
		14	22			2	7
B7	N.E. EQUAPAC GULF OUTFLOW	9	14			1	98
		14	22			2	2
B8	CENTRAL	13	21			1	100
B9	E. TRANSITION S.W. HAWAIIAN	10	16			1	19
		16	23			2	81
B10	E. TRANSITION N.E. HAWAIIAN	11	16			1	38
		16	23			2	62
B11	E. TRANSITION	10	18			1	100
B12	BAJA CALIFORNIA	6	13			1	100
B13	GULF OF CALIFORNIA	10	18			1	100
B14	E. TRANSITION N.W. HAWAIIAN	11	16			1	64
		16	22			2	36

PACIFIC AREA B

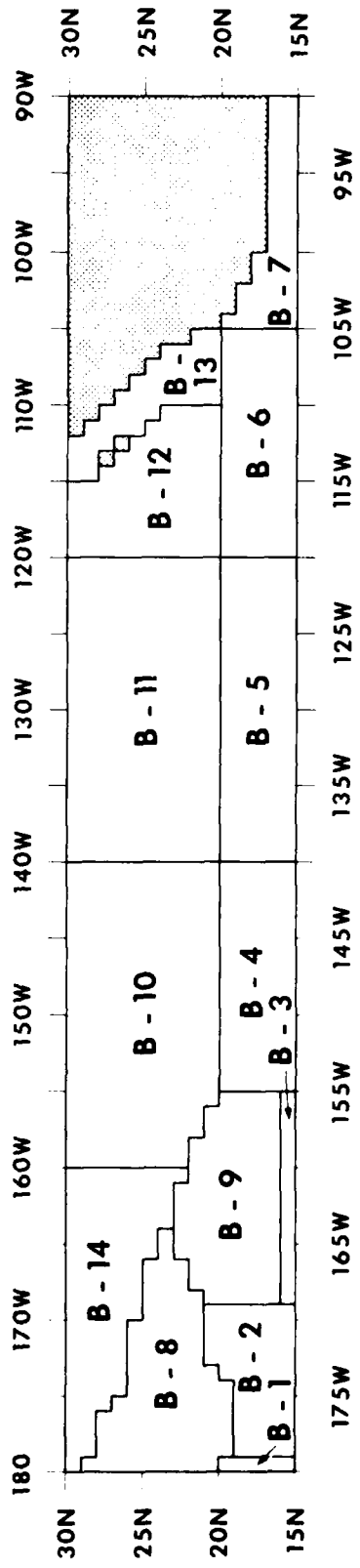

## PACIFIC AREA C

Region	Water Mass Name	T200 (°C)		DT (°C)		Position	Freq. (%)	Region	Water Mass Name	T200 (°C)		DT (°C)		Position	Freq. (%)
		Min	Max	Min	Max					Min	Max	Min	Max		
C1	E. KOREAN TSUSHIMA	10	16			1	83	C9	OYASHIO	2	8			1	18
		16	22			2	17		W. TRANSITION KUROSHIO	8	12			2	59
C2	SHIKOKU KUROSHIO	8	15			1	44	C10	LIMAN JAPAN CENTRAL	-2	3.5			1	83
	N.W. CENTRAL	15	23	-8.0	-3.0	2	13			12	18			3	21
		15	23	-3.0	0.0	3	43			3.5	8			2	17
C3	OYASHIO	5	11			1	4	C11	KURILE	-2	3.5			1	66
	W. TRANSITION	11	15			2	11		OYASHIO	3.5	8			2	27
	KUROSHIO	15	26	-8.0	-3.0	3	7		W. TRANSITION	8	12			3	7
	N.W. CENTRAL	15	26	-3.0	0.0	4	78								
C4	W. TRANSITION	6	15			1	16	C12	KURILE	-2	3.5			1	40
	KUROSHIO	15	22	-8.0	-3.0	2	13		OYASHIO	3.5	10			2	60
	N.W. CENTRAL	15	22	-3.0	0.0	3	71			0	5			1	23
C5	OYASHIO	5	10			1	3	C13	KURILE	5	13			2	77
	TRANSITION	10	14			2	38		OYASHIO	-2	6			1	100
	KUROSHIO	14	20			3	59			-2	4			1	100
C6	TRANSITION	7	13			1	30	C15	OKHOTSK	-2	4			1	100
	KUROSHIO	13	19			2	70			-2	6			1	100
C7	N. KOREAN	-2	3.5			1	71	C16	KURILE	-2	6			1	100
	JAPAN CENTRAL	3.5	8			2	21								
	E. KOREA	8	15			3	8								
C8	KURILE	-2	5			1	20								
	OYASHIO	5	10			2	37								
	W. TRANSITION	10	13			3	17								
	KUROSHIO	13	20	-8.0	-3.0	4	8								
	N.W. CENTRAL	13	20	-3.0	0.0	5	18								

# PACIFIC AREA C

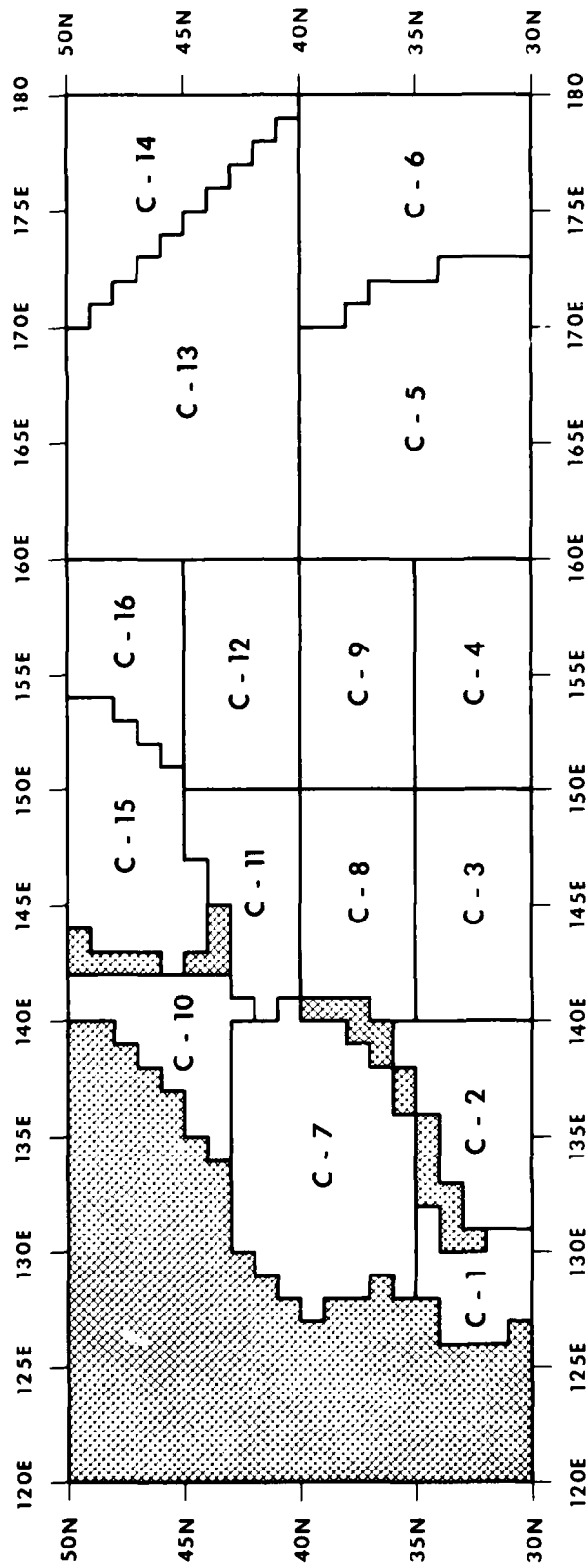

### PACIFIC AREA D

Region	Water Mass Name	T200 (°C)		DT (°C)		Position	Freq. (%)
		Min	Max	Min	Max		
D1	S. CHINA COLD S. CHINA WARM	11	17			1	96
		17	22			2	4
D2	LUZON W. CENTRAL	12	20			1	56
		20	26			2	44
D3	N.W. MARIANAS W. CENTRAL	12	19			1	30
		19	26			2	70
D4	E. MARIANAS W. CENTRAL	10	17			1	6
		17	26			2	94
D5	MARSHALLS CENTRAL	8	17			1	16
		17	26			2	84
D6	TAIWAN KUROSHIO N.W. CENTRAL	12	18			1	39
		18	26	-8.0	-3.0	2	32
		18	26	-3.0	0.0	3	29
D7	TAIWAN KUROSHIO N.W. CENTRAL	12	18			1	28
		18	26	-8.0	-3.0	2	11
		18	26	-3.0	0.0	3	61
D8	CENTRAL	12	24			1	100
D9	CENTRAL	12	24			1	100
D10	CENTRAL	13	21			1	100

PACIFIC AREA D

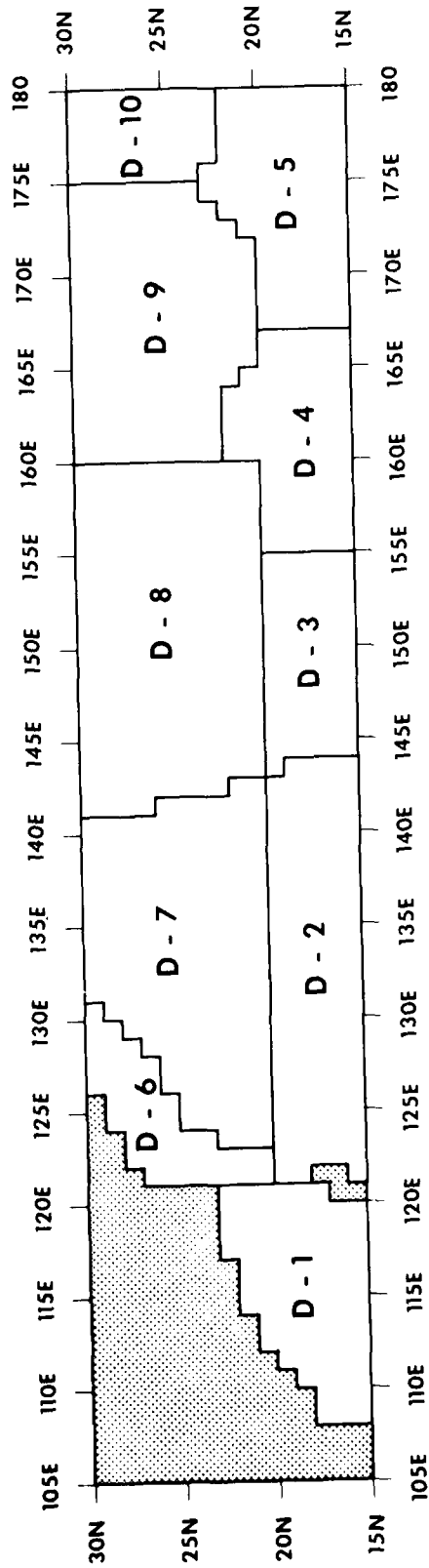

## PACIFIC AREA E

Region	Water Mass Name	T200 (°C)		DT (°C)		Position	Freq. (%)
		Min	Max	Min	Max		
E1	OKHOTSK	-2	4			1	100
E2	KURILE	-2	6			1	100
E3	KURILE	-2	6			1	100
E4	ALEUTIAN	0	6			1	100
E5	ALEUTIAN	0	8			1	100
E6	ALASKAN	0	9			1	100
E7	W. BERING	-2	6			1	100
E8	E. BERING	-2	6			1	100

PACIFIC AREA E

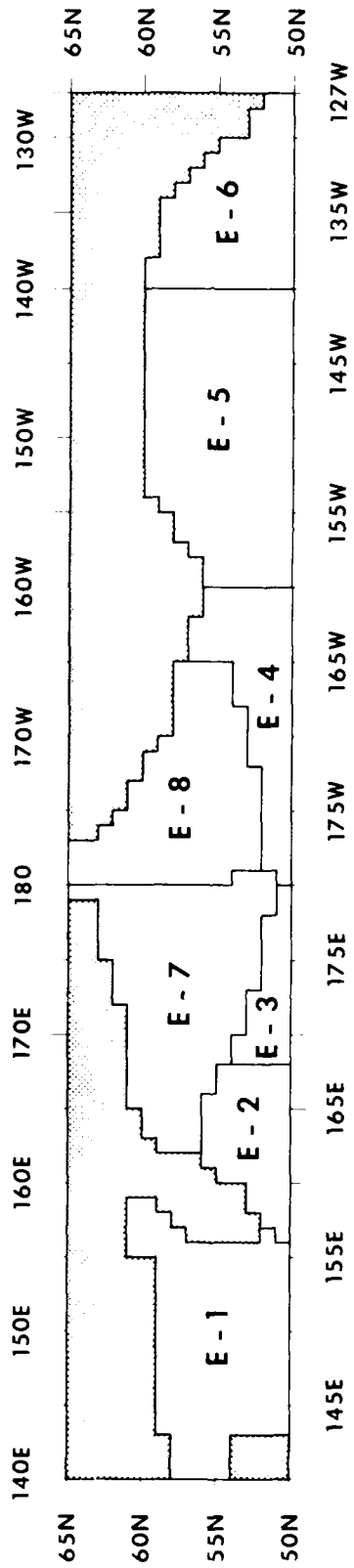

## PACIFIC AREA F

Region	Water Mass Name	T200 (°C)		DT (°C)		Position	Freq. (Z)
		Min	Max	Min	Max		
F1	N. EQUAPAC E. CENTRAL	8	14			1	19
		14	20			2	81
F2	N.E. EQUAPAC E. CENTRAL	9	14			1	82
		14	20			2	18
F3	N.E. EQUAPAC	9	15			1	100
F4	N.E. EQUAPAC	9	15			1	100
F5	GALAPAGOS	10	16			1	100
F6	PANAMA	10	15			1	100
F7	N. EQUAPAC E. CENTRAL	9	14			1	75
		14	21			2	25
F8	N. EQUAPAC E. CENTRAL	9	13			1	77
		13	20			2	23
F9	N.E. EQUAPAC E. CENTRAL S.E. HAWAIIAN	8	12			1	83
		12	16			2	15
		16	24			3	2
F10	N.E. EQUAPAC	8	15			1	100
F11	N.F. EQUAPAC GULF OUTFLOW	9	14			1	97
		14	22			2	3
F12	N.E. EQUAPAC GULF OUTFLOW	9	14			1	99
		14	22			2	1

PACIFIC AREA F

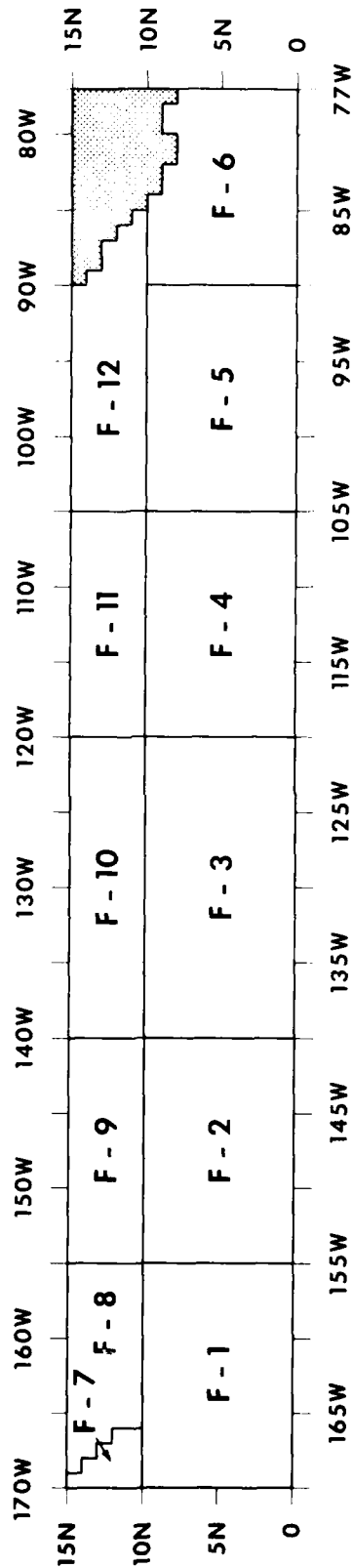

## PACIFIC AREA 6

Mission	Water Mass Name	T200 (°C)		DT (°C)		Position	Freq. (%)
		Min	Max	Min	Max		
G1	SULU/CELEBES	13	21			1	100
G2	MOLUCCA	12	21			1	100
G3	MINDANAO	8	15			1	16
	N.W. EQUAPAC	15	25			2	84
G4	CAROLINE	8	16			1	62
	N.W. EQUAPAC	16	26			2	38
G5	MELANESIAN	8	15			1	56
	N. EQUAPAC	15	26			2	44
G6	TROPAC	6	14			1	68
	N. EQUAPAC	14	24			2	32
G7	N. EQUAPAC	8	14			1	76
	E. CENTRAL	14	20			2	24
G8	S. CHINA COLD	12	19			1	100
G9	MINDANAO	8	15			1	84
	N.W. EQUAPAC	15	25			2	16
G10	MINDANAO	8	15			1	15
	SAMAR	15	20			2	64
	W. CENTRAL	20	26			3	21
G11	S.W. MARIANAS	12	18			1	44
	W. CENTRAL	18	25			2	56
G12	E. MARIANAS	10	17			1	66
	N. CENTRAL	17	26			2	34
G13	MARSHALLS	8	17			1	68
	CENTRAL	17	26			2	32
G14	N. EQUAPAC	9	14			1	42
	E. CENTRAL	14	21			2	58

PACIFIC AREA G

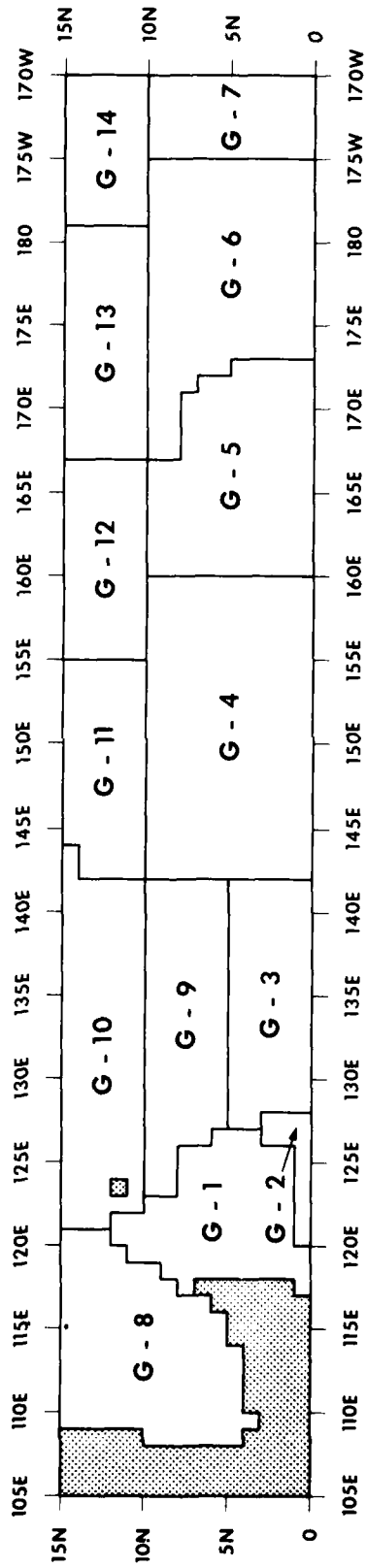



APPENDIX E  
WATER MASS CRITERIA  
INDIAN OCEAN  
(See Appendix C for explanation)

CONTENTS

	Page
Locator Charts . . . . .	83
Indian Area A . . . . .	84
Indian Area B . . . . .	86
Indian Area C . . . . .	88
Indian Area D . . . . .	90



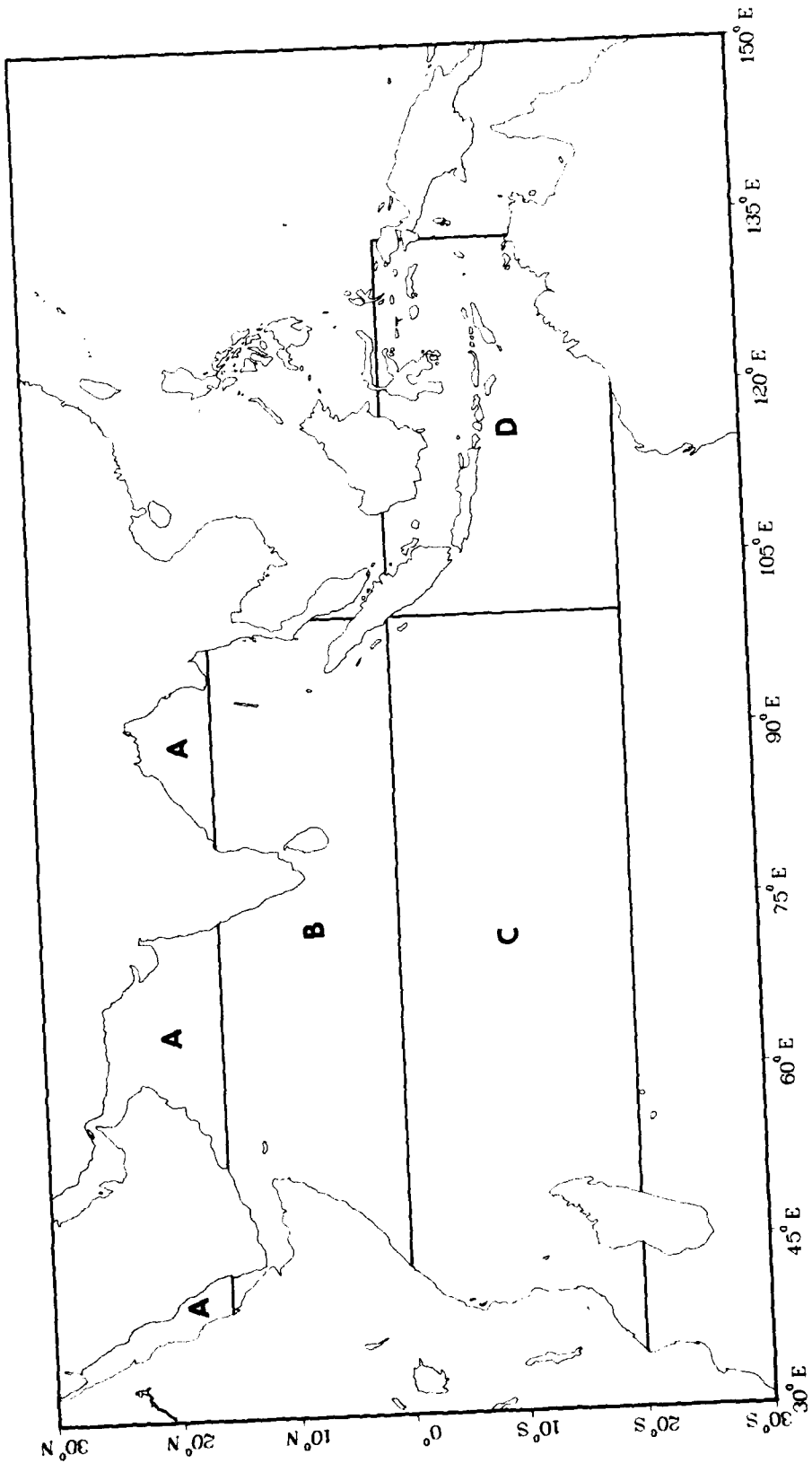

### INDIAN AREA A

Region	Water Mass Name	T200 (°C)		DT (°C)		Position	Freq. (%)
		Min	Max	Min	Max		
A1	RED SEA	19	26			1	100
A2	YEMEN COOL	12	16			1	36
	YEMEN WARM	16	21			2	64
A3	ARABIAN	12	19			1	100
A4	NORTH INDIAN COLD	11	15			1	72
	NORTH INDIAN WARM	15	20			2	28
A5	GULF OF OMAN	16	22			1	100
A6	PAKISTAN I	15	22			1	100

INDIAN AREA A

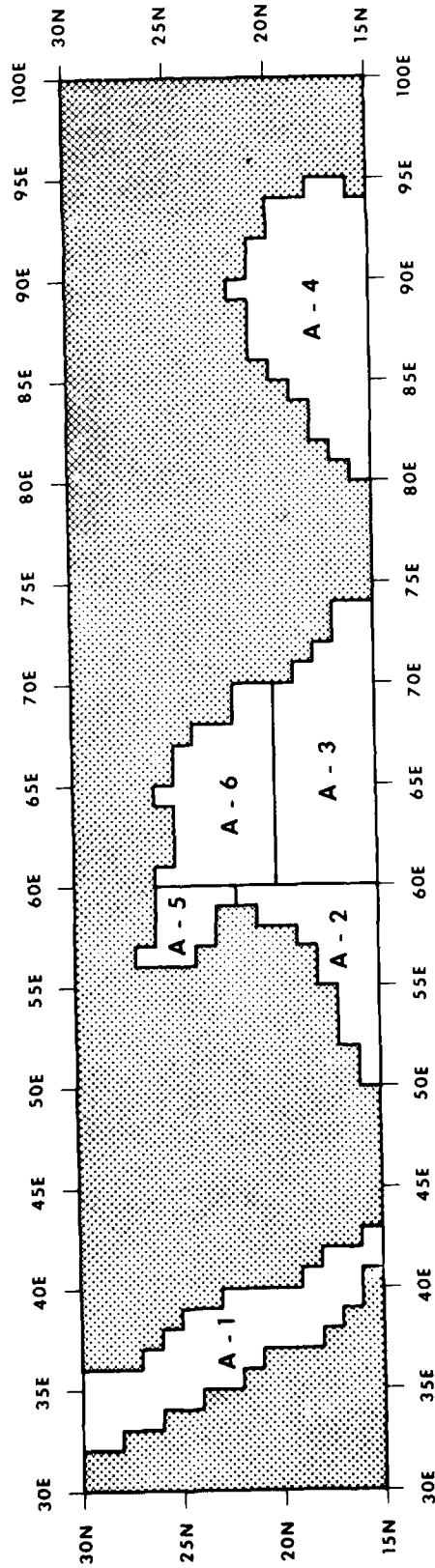

### INDIAN AREA B

Region	Water Mass Name	T200 (°C)		DT (°C)		Position	Freq. (%)
		Min	Max	Min	Max		
B1	N.W. SOMALI COOL	12	16			1	91
	N.W. SOMALI WARM	16	22			2	9
B2	N.W. SOMALI	12	18			1	100
B3	ARABIAN	12	18			1	100
B4	MID-INDIAN COLD	10	14.5			1	82
	MID-INDIAN WARM	14.5	19			2	18
B5	EAST INDIAN	10	17			1	100
B6	NORTH SOMALI COOL	12	16			1	74
	NORTH SOMALI WARM	16	22			2	26
B7	ARABIAN	13	19			1	100
B8	CEYLON	12	18			1	100
B9	NORTH INDIAN COLD	11	15			1	76
	NORTH INDIAN WARM	15	20			2	24
B10	ANDAMAN	10	17			1	100
B11	WEST ADEN	12	18			1	100
B12	EAST ADEN	12	18			1	100
B13	YEMEN COOL	12	16			1	60
	YEMEN WARM	16	21			2	40
B14	ARABIAN	13	19			1	100

INDIAN AREA B

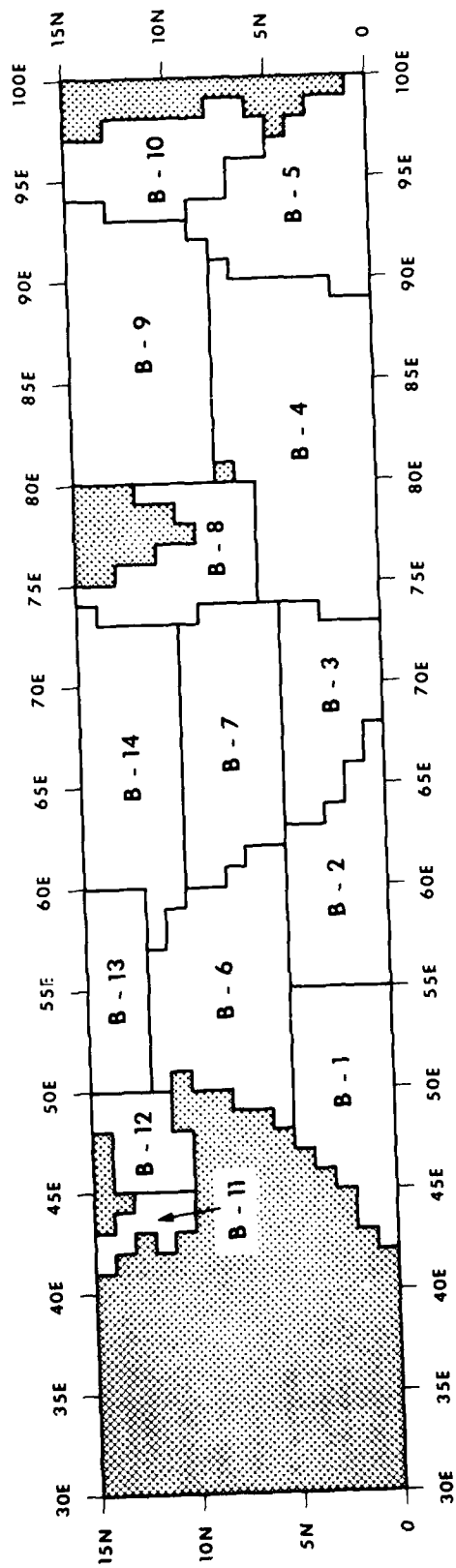

## INDIAN AREA C

Region	Water Mass Name	T200 (°C)		DT (°C)		Freq. (%)	Position	Region	Water Mass Name	T200 (°C)		DT (°C)		Freq. (%)
		Min	Max	Min	Max					Min	Max	Min	Max	
C1	S. MOZAMBIQUE COLD	11	17			30	1	C11	WEST SOMALI	11	18			100
	S. MOZAMBIQUE WARM	17	22			70	2	C12	NORTH MASCARENE	11	18			100
C2	S. MASCARENE	15	22			100	1	C13	EAST SOMALI	11	18			100
C3	MAURITIUS	14	22			100	1	C14	MID INDIAN	11	18			100
C4	SOUTH INDIAN	15	22			100	1	C15	EAST INDIAN COLD	10	14			84
C5	SOUTH WHARTON	14	21			100	1		EAST INDIAN WARM	14	20			16
C6	N. MOZAMBIQUE COLD	13	17			50	1	C16	N.W. SOMALI	10	18			100
	N. MOZAMBIQUE WARM	17	23			50	2	C17	N.W. SOMALI	10	18			100
C7	CENTRAL MASCARENE COLD	10	15			44	1	C18	ARABIAN	12	18			100
	CENTRAL MASCARENE WARM	15	20			56	2							
C8	SOUTH SOMALI	13	20			100	1	C19	MID INDIAN COLD	10	14.5			83
C9	SOUTH INDIAN COLD	10	15			60	1		MID INDIAN WARM	14.5	19.0			17
	SOUTH INDIAN WARM	15	22			40	2	C20	EAST INDIAN COLD	10	14			84
C10	WHARTON COLD	10	15			42	1		EAST INDIAN WARM	14	20			16
	WHARTON WARM	15	22			58	2							

AD-A085 947

NAVAL OCEANOGRAPHIC OFFICE NSTL STATION MS  
OCEANOGRAPHIC ANALYSIS MANUAL FOR ON-SCENE PREDICTION SYSTEMS (U)  
MAY 78 A FISHER

F/6 8/10

UNCLASSIFIED

NOO-RP-20

NL

2 of 2  
of 2



END  
DATE  
FILMED  
8-80  
DTIC

085947

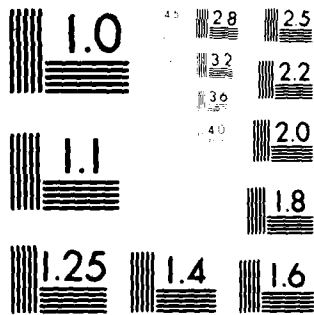

MICROCOPY RESOLUTION TEST CHART  
1963-A

INDIAN AREA C

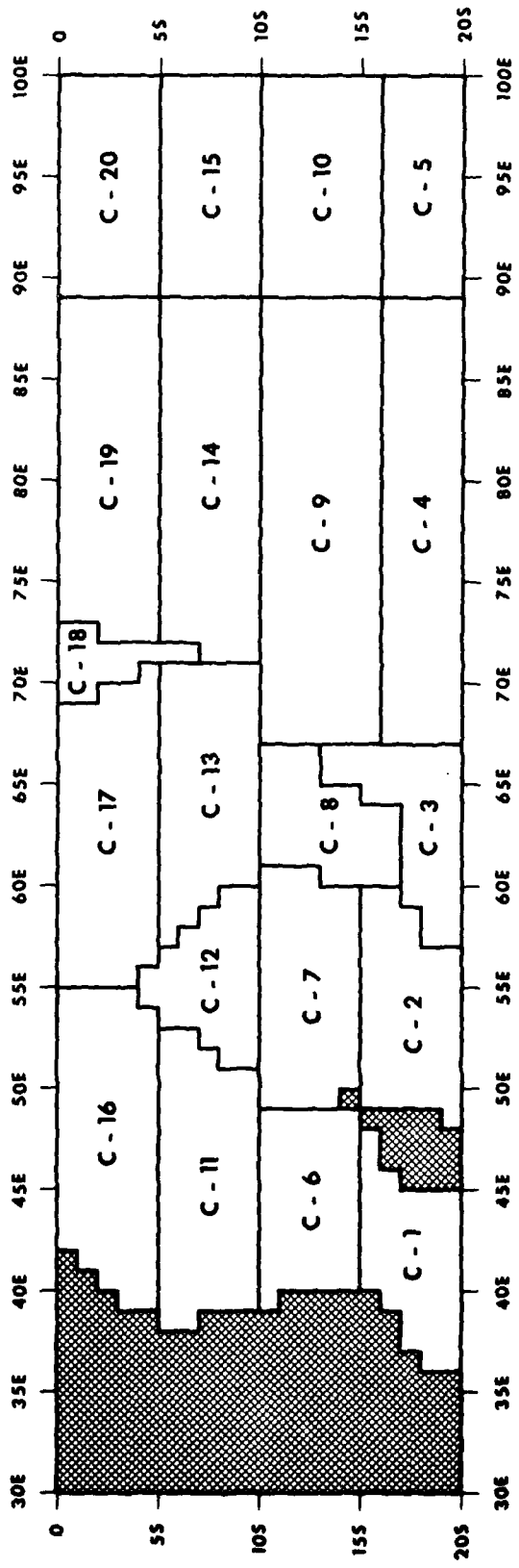

## INDIAN AREA D

Region	Water Mass Name	T200 (°C)		DT (°C)		Position	Freq. (Z)
		Min	Max	Min	Max		
D1	SOUTH WHARTON	14	21			1	100
D2	AUSSIE WARM	13	22			1	100
D3	TIMOR	11	19			1	100
D4	WHARTON COLD	9	15			1	56
	WHARTON WARM	15	22			2	44
D5	AUSSIE COLD	9	15			1	61
	AUSSIE WARM	15	21			2	39
D6	E. INDIAN COLD	10	14			1	81
	E. INDIAN WARM	14	20			2	19
D7	SUNDA	8	18			1	100
D8	S. JAVA	9	19			1	100
D9	MAKASSAR/FLORES	11	19			1	100
D10	BANDA COLD	10	15			1	36
	BANDA WARM	15	20			2	64
D11	E. CHINA COLD	10	14			1	88
	E. CHINA WARM	14	20			2	12
D12	MOLUCCA	12	21			1	100
D13	CERAM	13	22			1	100

INDIAN AREA D

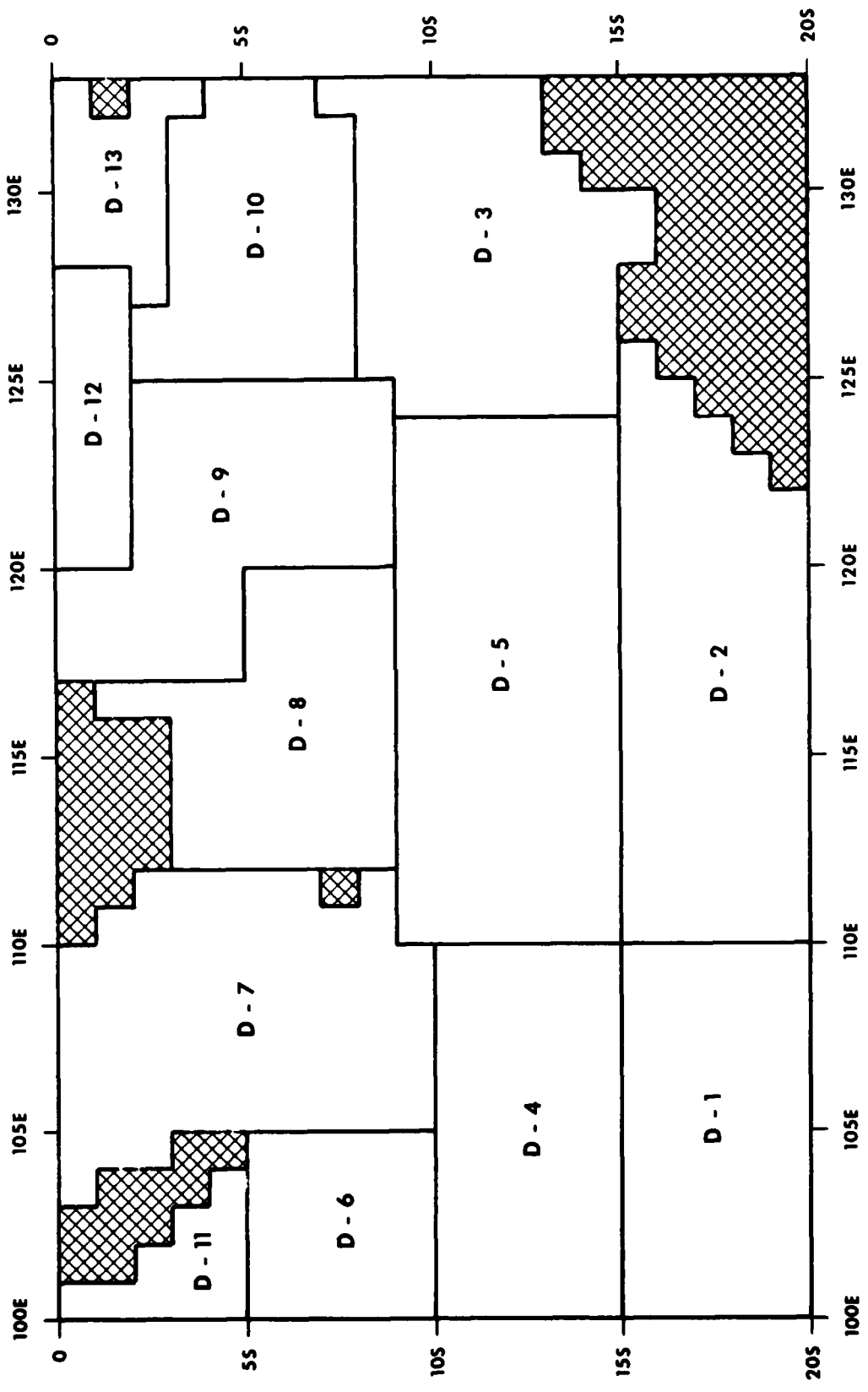



APPENDIX G  
GLOSSARY OF ACRONYMS

ASW	- Antisubmarine Warfare
BATHY	- Bathythermograph data encoded for transmission
BB	- Bottom Bounce
BLG	- Below-layer Gradient
BT	- Bathythermograph
CZ	- Convergence Zone
DR	- Dead Reckoning
DT	- Temperature at 300m minus temperature at 200m
DTG	- Day/Time/Group
FLENUMWEACEN	- Fleet Numerical Weather Central, Monterey
ICAPS	- Integrated Command ASW Prediction System
ILG	- In-layer Gradient
IR	- Infrared
NWPCB	- Naval Warfare Planning Chart Base
SLD	- Sonic Layer Depth
SOA	- Speed of Advance
SST	- Sea Surface Temperature
TL	- Temperature at the base of the below layer gradient
TSLD	- Temperature at Sonic Layer Depth
T200	- Temperature at the 200-m level. Temperature at any level has a prefix "T" followed by the depth.
XBT	- Expendable Bathythermograph

DISTRIBUTION LIST

COMSECONDFLT  
 COMSIXTHFLT  
 COMSEVENTHFLT  
 CTF 69  
 COMSURFWARDEVGRU  
 COMSUBDEVGRU ONE  
 COMSUBDEVRON TWELVE  
 COMNAVINTCOM  
 DIRNAVOCEANMET  
 CINCLANT  
 CINCPACFLT  
 COMSUBLANT  
 COMSUBFAC  
 FLENUMWEACEN  
 FLETRACEN  
 COMASWSUPPTRA DET  
 NAVPGSCOL  
 COMNAVAIRLANT  
 NATC 2 copies  
 NAVAIRDEVGEN 2 copies  
 CNO (OP 951)  
 COMNAVAIRSYS  
 USS SARATOGA (CV-60) 2 copies  
 USS AMERICA (CV-66) 2 copies  
 FLEWEACEN ROTA  
 " NORFOLK  
 " PEARL HARBOR  
 " GUAM  
 TSC BERMUDA 2 copies  
 TSC LAJES 2 copies  
 TSC MOFFETT 2 copies  
 NAVWEASERVFAC ALAMEDA  
 " GLENVIEW  
 " JACKSONVILLE  
 " PENSACOLA  
 " SAN DIEGO  
 " YOKOSUKA  
 NWSAD ADAK  
 " AGANA  
 " ATSUGI  
 " BARBERS POINT  
 " BERMUDA  
 " BRUNSWICK  
 " CECIL FIELD  
 " CUBI POINT  
 " KADENA  
 " KEFLAVIK  
 " MISAWA  
 " MOFFETT FIELD  
 " NAPLES  
 " PATUXENT RIVER  
 " ROOSEVELT ROADS  
 " SIGONELLA  
 NORDA 2 copies  
 NUSC 2 copies



**UNCLASSIFIED**

**SECURITY CLASSIFICATION OF THIS PAGE(When Data Entered)**

**ABSTRACT continued:**

of each water mass for input into acoustic models is discussed.

**UNCLASSIFIED**

**SECURITY CLASSIFICATION OF THIS PAGE(When Data Entered)**

