

SL

(12)

LEWELL

RADC-TR-80-103
Final Technical Report
April 1980



ADA 085983

MANUFACTURING STUDY FOR A FOUR METER LIGHTWEIGHT MIRROR

Corning Glass Works

Sponsored by
Defense Advanced Research Projects Agency (DoD)
ARPA Order No. 3503

APPROVED FOR PUBLIC RELEASE; DISTRIBUTION UNLIMITED

The views and conclusions contained in this document are those of the authors and should not be interpreted as necessarily representing the official policies, either expressed or implied, of the Defense Advanced Research Projects Agency or the U.S. Government.

ROME AIR DEVELOPMENT CENTER
Air Force Systems Command
Griffiss Air Force Base, New York 13441

DTIC
ELECTE
S JUN 24 1980 D

A

DOC FILE COPY

80 6 28 002

This report has been reviewed by the RADC Public Affairs Office (PA) and is releasable to the National Technical Information Service (NTIS). At NTIS it will be releasable to the general public, including foreign nations.

RADC-TR-80-103 has been reviewed and is approved for publication.

APPROVED:

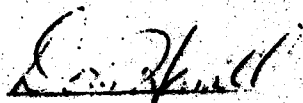

DORIS HAMILL, 1Lt, USAF
Project Engineer

If your address has changed or if you wish to be removed from the RADC mailing list, or if the addressee is no longer employed by your organization, please notify RADC (OCSE), Griffiss AFB NY 13441. This will assist us in maintaining a current mailing list.

Do not return this copy. Retain or destroy.

MANUFACTURING STUDY FOR A FOUR METER LIGHTWEIGHT MIRROR

W. E. Bliss
P. C. Cleveland

Contractor: Corning Glass Works
Contract Number: F30602-79-C-0225
Effective Date of Contract: 4 Sep 79
Contract Expiration Date: 30 Nov 79
Short Title of Work: Manufacturing Study for a Four Meter
Lightweight Mirror
Program Code Number: OE20
Period of Work Covered: Sep 79 - Nov 79
Principal Investigator: Eldon Decker
Phone: 607 974-4147
Project Engineer: 1Lt Doris Hamill
Phone: 315 330-3148

Approved for public release; distribution unlimited.

This research was supported by the Defense Advanced
Research Projects Agency of the Department of Defense
and was monitored by 1Lt Doris Hamill (OCSE), Griffiss
AFB NY 13441 under Contract F30602-79-C-0225.

UNCLASSIFIED

SECURITY CLASSIFICATION OF THIS PAGE (When Data Entered)

19 REPORT DOCUMENTATION PAGE		READ INSTRUCTIONS BEFORE COMPLETING FORM	
18 1. REPORT NUMBER RADC TR-80-103	2 GOVT ACCESSION NO. AD-A085983	3 RECIPIENT'S CATALOG NUMBER	
6 4. TITLE (and Subtitle) MANUFACTURING STUDY FOR A FOUR METER LIGHTWEIGHT MIRROR		9 5. TYPE OF REPORT & PERIOD COVERED Final Technical Report, 4 Sep - 30 Nov 79	
10 6. AUTHOR(s) W. E. Bliss P. C. Cleveland		7 7. PERFORMING ORG. REPORT NUMBER N/A	
9 8. CONTRACT OR GRANT NUMBER(s) F30602-79-C-0225 <i>new</i> WARPA Order-35031		15 9. PROGRAM ELEMENT, PROJECT, TASK AREA & WORK UNIT NUMBERS 62301E C5030105	
11 10. PERFORMING ORGANIZATION NAME AND ADDRESS Corning Glass Works Corning NY 13617		16 11. REPORT DATE Apr 1980	
11 11. CONTROLLING OFFICE NAME AND ADDRESS Defense Advanced Research Projects Agency 1400 Wilson Blvd Arlington VA 22209		17 12. NUMBER OF PAGES 88	
14 12. MONITORING AGENCY NAME & ADDRESS (if different from Controlling Office) Rome Air Development Center (OCSE) Griffiss AFB NY 13441		15 13. SECURITY CLASS. (of this report) UNCLASSIFIED	
		15a 14. DECLASSIFICATION/DOWNGRADING SCHEDULE N/A	
16 15. DISTRIBUTION STATEMENT (of this Report) Approved for public release; distribution unlimited.			
12 83			
17 16. DISTRIBUTION STATEMENT (of the abstract entered in Block 20, if different from Report) Same			
18 17. SUPPLEMENTARY NOTES RADC Project Engineer: Doris Hamill, 1Lt, USAF (OCSE)			
19 18. KEY WORDS (Continue on reverse side if necessary and identify by block number) Lightweight Mirror Seal Plane Boule Front Plate Core Back Plate Flowout			
20 19. ABSTRACT (Continue on reverse side if necessary and identify by block number) This study was performed to determine the feasibility of manufacturing a four-meter diameter lightweight mirror. It concludes that it is possible to build and assemble such a mirror. Except for grinding, present equipment can be modified to handle this size mirror. A grinding machine capable of handling this size is commercially available. This study identifies three developments which should be accomplished in order to minimize the risk of such an undertaking. 4			

099150

dw

UNCLASSIFIED

SECURITY CLASSIFICATION OF THIS PAGE(When Data Entered)

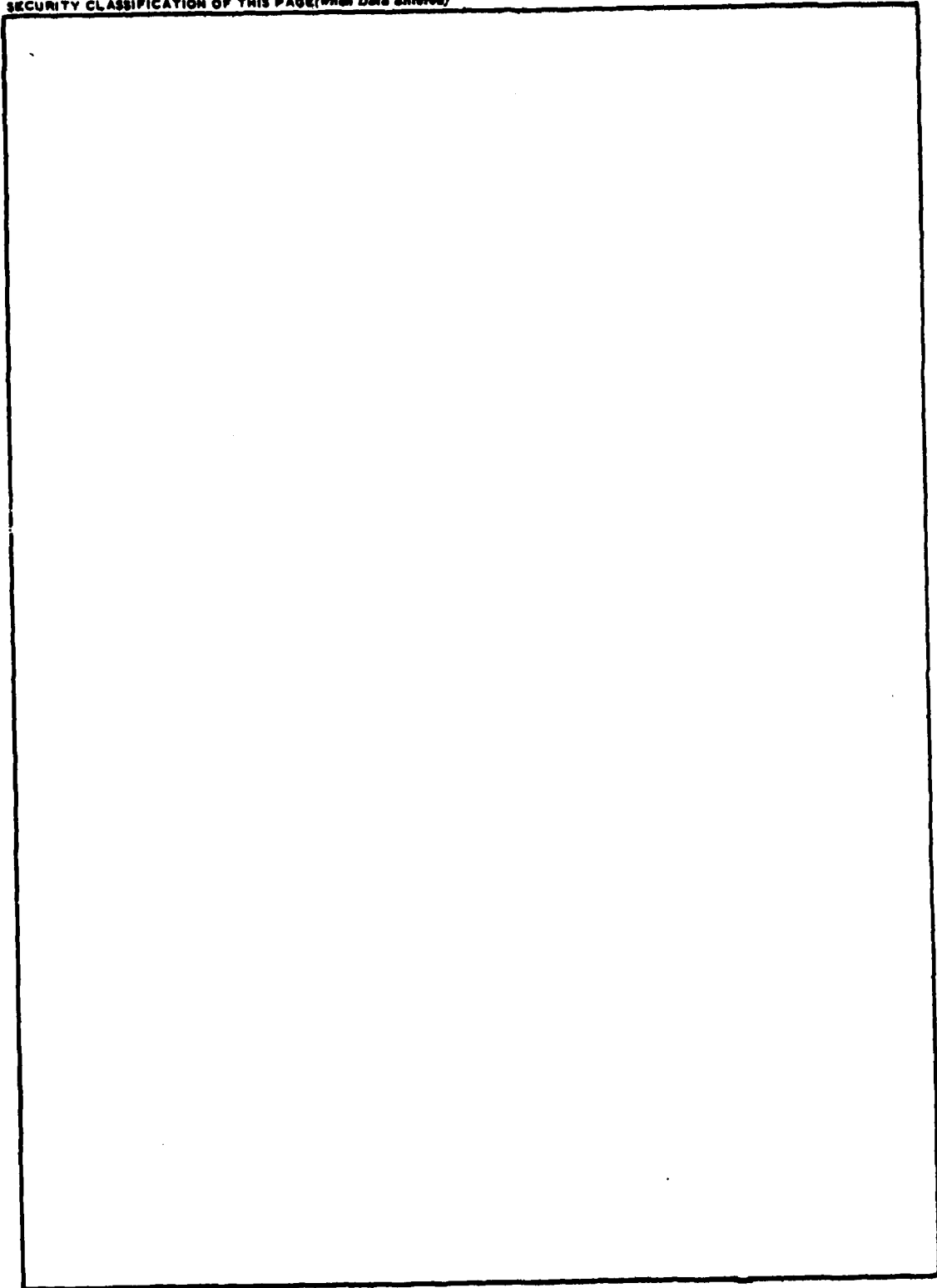

UNCLASSIFIED

SECURITY CLASSIFICATION OF THIS PAGE(When Data Entered)

TABLE OF CONTENTS

	<u>Page</u>
1.0 Introduction	1
2.0 Main Text - Light Weight Mirror Manuf. Steps	2
2.1 Batch Preparation	2
2.2 Glass Laydown - Flame Hydrolysis	2
2.3 Plate Flowout	4
2.4 Stack Sealing	6
2.5 Plate Sagging	7
2.6 Plate Grinding	8
2.7 EII Grinding (Struts & Posts)	11
2.8 EII Making	11
2.9 Core Sealing	12
2.10 Ring Manufacturing & Sagging	13
2.11 Ring Sealing	14
2.12 Core Grinding	15
2.13 Cleaning	17
2.14 Sealing	18
2.15 Annealing	19
3.0 Conclusions	21
4.0 Recommendations	23
5.0 Equipment Costs	24
5.1 2400 lb. Boule Furnace	24
5.2 Plate Sagging	24
5.3 Mirror Component Grinding	24
5.4 EII Making	24
5.5 Core Sealing	25
5.6 Ring Sealing	25
5.7 Cleaning	25
5.8 Cleaning	25
5.9 Handling Equipment	26
5.10 Annealing	26

Accession For	
NTIS GOR&I	<input checked="" type="checkbox"/>
DDC TAB	<input type="checkbox"/>
Unclassified	<input type="checkbox"/>
Justification	
Availability Codes	
Dist	Avail and/or special
H	

TABLE OF CONTENTS (Cont'd)

	<u>Page</u>
6.0 Developments	27
6.1 2400 lb. Boule	27
6.2 Plate Flowout (1300 lb. Boules)	27
6.3 Core Sealing	27
6.4 Total Cost	27
6.5 Engineering hours	27
7.0 Illustrations	28
8.0 Tables	56
9.0 Gantt Charts	64

LIST OF ILLUSTRATIONS

	<u>Page</u>
7.1 "Graph" Plate Thickness vs. Stress (Edge Loaded)	28
7.2 "Graph" Plate Thickness vs. Stress (Center Loaded)	29
7.3 "Graph" Plate Thickness vs. Deflection (Edge Loaded)	30
7.4 Stack Sealing	31
7.4.1 Assembly	31
7.4.2 Furnace Loading	32
7.4.3 Finished Stack	33
7.5 Flowout (1300 lb. Boule)	34
7.5.1 1-4 Flowouts	34
7.5.2 5-8 Flowouts	35
7.5.3 1-4 Flowouts (2400 lb. Boule)	36
7.6 Sag Mold Making	37
7.7 Plate Sagging	38
7.8 Plate Grind	39
7.8.1 Plano-Plano Grind	39
7.8.2 Concave-Convex Plate Grind	40
7.9 Ell Grinding (Posts and Struts)	41
7.10 Ell Making	42
7.11 Core Sealing	43
7.11.1 Takeout Table	43
7.11.2 Core Sealer	44
7.12 Ring Segment Sagging	45
7.13 Ring Sealing	46
7.14 Core Grinding	47
7.14.1 Rough Core	47
7.14.2 Core Lapping	48
7.14.3 Core Chucking	49
7.14.4 Core Grinding - Convex Side	50
7.14.5 Core Flopping	51
7.14.6 Core Grinding - Concave Side	52
7.15 Cleaning	53
7.16 Sealing	54
7.16.1 Assembly	54
7.16.2 Firing	55

LIST OF TABLES

	<u>Page</u>
8.0 Tables	56
8.1 Process List	56
8.2 Mirror Specifications	57
8.3 Manpower	58
8.4 Manufacturing Cost (60" Boule)	59
8.5 Manufacturing Cost (2400 lb. Boule)	60
8.6 Flowout Data	61
8.7 Glass Requirements	62
8.7.1 60" Boules	62
8.7.2 100" Boules	62
8.7.3 Wax Plate	62

GLOSSARY

- Alpha - Coef. of thermal expansion.
- Boule - The disc of glass formed in the furnace.
- Cell - Single section of core.
- Core - Hollow sections in mirror center.
- Crossarm - Support device to lift large mirrors and plates with a fork truck.
- E11 - Half section of a cell.
- Flopping - The turning over of large plates, cores, or mirrors.
- Flowout - Method used to produce large diameter plates from small diameter boules.
- Glass - Used in the report to mean ULETM.
- Post - Corner section to which 2 struts are sealed to form an ell.
- Spider - Spring loaded lifting device made up of many cables to lift cores.
- Squash - The movement applied to heated edges in ell and core making to form a seal.
- Stack - Method used to produce thick sections of glass.
- Standard boule - 60" diameter @ 1300.
- Starter strip - Section of glass used to start core manufacture.
- Strut - Flat piece of glass used to form a cell.
- Takeout table - Machine used to support core and move outward as it is formed.
- Wax plate - A disc of glass used for chucking mirror parts.

1.0 INTRODUCTION

- 1.1 This study addresses equipment and process needs to manufacture a passive lightweight mirror blank in a 4 meter diameter size.
- 1.2 In approaching this it was necessary to assume a design for the 4 meter blank. The assumed design parallels the recently manufactured space telescope blanks for NASA and Table 8.2 lists the physical aspects considered in this study. This does not intend to "freeze" a design, but instead seeks a mean size to work with.
- 1.3 This manufacturing study is based on the extension of proven technology as modified to be applicable to a 4 meter mirror and does not rely on technological inventions. The method selected to prepare the study was to divide the process into fifteen (15) major steps (Table 8.1). Each of these steps were further broken down into feasibility, probability of success, design plan or general process, equipment required, equipment costs and delivery, detailed engineering required, developments required, plant changes and costs, and manufacturing cost. This report will deal with each of these process steps.
- 1.4 Preliminary cost estimates, made without the benefit of detailed engineering designs are expressed in 1979 dollars.
- 1.5 Gantt charts were prepared for glass forming, equipment procurement, and mirror manufacture. These charts can be found in Section 9.0.

2.0 MAIN TEXT - LIGHT WEIGHT MIRROR MANUF. STEPS

2.1 Batch Preparation

2.1.1 The batch consists of the proper mixture of SiCl_4 and TiCl_4 . This is accomplished by a weight process using electronic scales. The batch is then placed in recirculating storage tanks until it is used in the glass forming furnaces.

2.1.2 The batch system has functioned successfully in maintaining glass expansion consistency for the completed lightweight mirror programs. The system also has the capacity to furnish batch far in excess of the requirement for this program.

2.2 Glass Laydown - Flame Hydrolysis

2.2.1 The laydown process is the operation where the SiCl_4 and TiCl_4 are combined with heat in the furnace to form the glass. The furnaces currently in use to furnish a 60" boule of glass approximately 1300 lbs. in weight. This size boule has been used in prior programs with success.

2.2.2 Boules of the 1300 lb. size will furnish the material for the 4 meter mirror, however, there is some question as to the quality of a front plate resulting from the flowing out of a 1300 lb. boule.

2.0 MAIN TEXT (Cont'd)

- 2.2.3 As will be seen in Section 2.3, the preferred solution to the problem posed in attaining 160" diameter front plates from 60" diameter boules is to manufacture larger boules, i.e. 100" in diameter. Experiments conducted over the past few years on the current furnaces have demonstrated options for the design of a larger furnace, and there is a high probability of success.
- 2.2.4 The construction of a larger furnace will require several plant changes. An additional furnace room must be put into operation. This consists of installation of all new services. The duct work from the furnace to the stack fan must also be constructed. An additional stack fan must be added to handle the extra exhaust load. The cost to build and install the furnace is included in the cost section (5.1).
- 2.2.5 The operation of the new furnace would require a development program. The purpose of the development effort would be to learn the operating parameters that will produce glass of satisfactory quality. This proposed program would consist of 10 runs having a two week duration each. The furnace operation would be programmed and controlled by engineering personnel. Acceptable glass produced during the experiment will be used in other areas of the program. The program goal is a 100" diameter, 4" thick boule.

2.0 MAIN TEXT (Cont'd)

2.3 Plate Flowout

- 2.3.1 The flowout process is designed to produce plates that are larger than 60" in diameter from a standard 60" boule. It involves heating a stack of boules to an elevated temperature that softens the glass and allows it to flow out unconstrained to the larger diameter. In order to keep the seal planes reasonably parallel to the surfaces of the flowed-out stack, a system of partial flowouts is used with alternate sides of the stack up and, therefore, most free to flow. In the case of flowout of standard 60" diameter boules to about 165", eight separate flowout steps would be used. Illustrations 7.5.1 - 7.5.3 demonstrate the process, and Table 8.6 shows the desired diameter for each flowout. The stack rests on some loose material during flowout and some of this imbeds in the surface of the glass. This must be machined from the surface after each flowout.
- 2.3.2 The plates made by the flowout process fall into two categories. The first being wax plates used in the process to support core grinding. These plates are not critical quality wise. The second plates are the surface plates of the mirror. The mirror front plate not only has to be of polishable quality, but ideally would come from a single boule of glass.

2.0 MAIN TEXT (Cont'd)

- 2.3.3 Historically, all of the material in the final front plate has come from a single boule, which has made it possible to avoid any problem that might arise if the finish plane would intersect a seal plane. Seal planes typically contain many fine bubbles that could cause difficulties during use of loose abrasives in the finishing process. However, for plates this large, the flowout thickness of a single boule is 0.70 inch, and since a typical variation in seal plane flatness is 0.40 inch, the available thickness from a single boule is only 0.30 inch. Clearly, there is not enough glass to produce an 0.80 inch thick final plate of material all from a single boule. Either we must manufacture larger boules for these plates, or attempt to find a method that can produce an acceptable plate that contains material from two boules and be certain that the seal plane will not intersect the finish plane of the final mirror.
- 2.3.4 Flowout developments are proposed to study the characteristics of a 4 meter diameter plate to evaluate alternate approaches, namely a plate made from larger boules or a plate containing material from two boules.
- 2.3.5 The 60" flowout development would use fourteen (14) 1300 lb. boules. The cost of the glass and the development is covered in 6.2. A reasonable estimate is that 75% of the glass produced during the experiment can be used in other phases of the program.

2.0 MAIN TEXT (Cont'd)

- 2.3.6 The 60" boule approach would be to select the flattest seal plane found in a flowout, and map the seal plane relative to a flat surface by use of a depth microscope that focuses on the tiny bubbles in the seal plane. Then, either grind a prescription into the glass, and flow the boule flat, or alternatively put the prescription in a brick mold, sag the glass into it, and grind flat.
- 2.3.7 The preferred solution is to increase the boule diameter. A 100" diameter (2400 lbs.) boule with approximately 4" thickness would produce 1.4" of glass when flowed to 165" in diameter. The light-weight mirror programs completed to date confirm that this will produce a usable plate. The glass forming development program required to produce a 2400 lb. boule is found in 6.1.
- 2.3.8 Both flowout methods offer the same high probability of success. Final mirror design and time constraints may dictate which approach must be taken.

2.4 Stack Sealing

- 2.4.1 Stack sealing is a process to produce glass high enough to make the posts and struts. The 4 meter mirror requires a post and strut length of 28". To obtain this glass height, six 60" boules are placed in a furnace and sealed together. Illustrations 7.4.1 - 7.4.3 depict the method used.

2.0 MAIN TEXT (Cont'd)

2.4.2 The present in-house equipment can produce this post and strut stack. The cost for stack production is included in the cost section.

2.5 Plate Sagging

2.5.1 The depth of the mirror curved surfaces is approximately 7". This depth dictates that flat plates must be sagged. The sagging operation consists of generating a male (convex up) mold of soft brick in the furnace (Illus. 7.6). The top of the mold is flattened and the flat blank is placed on the flattened surface. The size of the mold flat is critical in that it determines the bending stress in the plate. Illustration 7.2 is a graph which plots flat diameter vs. plate thickness for a bending stress of 1,000 and 750 psi. Plates sagged on previous programs have had stresses in the 1,000 psi range.

2.5.2 The sagging operation will consist of making three plates. The first will be used to support the core during grinding. This is called a "wax plate" since the core is actually waxed to this plate grinding. This plate will be kept as thick as possible (3½-4") for maximum support and minimum deflection during core grinding. The "wax plate" poses little problem during sagging due to its thickness (3½-4"). A look at the graph on Illus. 7.2 will show this. The other units are the front and back plates. These plates are ground to

2.0 MAIN TEXT (Cont'd)

2.5.2 1½" thick on the mirror blank. The plates grind easier in the flat configuration, thus it is an advantage to keep them as thin as possible. A study of Illus. 7.2 shows that a 1½" plate would require a flat in excess of 24" diameter. The center hole in the mirror may be in this area, thus a smaller flat must be used. The compromise of a 16" diameter and a 2" thick plate looks like a very good choice. Care must also be taken to maintain a constant seal plane during sagging.

2.6 Plate Grinding

2.6.1 The plate grinding requires a new machine to handle the size. Campbell Grinder Co. of Muskegon, Michigan, builds a 180" dia. table grinding machine. The machine would be equipped with a tracer system for the contour grinding. Interchangeable grinding heads would allow drilling, as well as grinding. The machine table would be equipped with jacks and holding fixtures to load and chuck the plates. The cost and delivery of such a machine is included in the equipment section.

2.6.2 Plate grinding consists of four grinding operations. The operations are plano-plano surface machining, concave-convex surface machining, core drilling, and edge machining.

2.6.3 The program requires the machining of four plates. The plates are a plano-plano "wax plate," a concave-convex "wax plate," and a concave-convex back and front plate.

2.0 MAIN TEXT (Cont'd)

2.6.4 The plano-plano "wax plate" is used for lapping the core flat on one side. It is also used to chuck the core for the first surface contour grind. The chucking is accomplished by waxing the core to the plate. The machining process consists of placing the rough plate on the machine jacks, using a fork truck. The jacks then lower the plate to the machine table surface. The plate is shimmed level, clamped tight and finished, using a large cup wheel (see Illus. 7.8.1). The first surface is ground only enough to give a smooth mounting area. The plate is removed from the machine, turned over, remounted and the second surface is finished. The plate should be thick as possible so a minimum of grinding is required. The plate does not require a hole or the edge finished.

2.6.5 The concave-convex "wax plate" must be flat ground per 2.6.4 prior to sagging. The sagged plate is placed on the machine jacks with the fork truck. The machine will be furnished with a holding fixture to cradle the sagged part. The jacks lower the part into the cradle where it is shimmed (sagged surface is rough) and clamped tight (see Illus. 7.8.2). The concave side is ground first. This allows the part to be more carefully shimmed in the chucking cradle. The coolant must be pumped from the plate during grinding. The surface is machined using the proper grinding head furnished with the machine. The part is removed from the machine, using the jacks and fork truck. The chucking cradle

2.0 MAIN TEXT (Cont'd)

2.6.5 is changed on the machine to accommodate a concave surface. The part is turned over and placed in the chucking cradle, following the same procedure. The convex surface is now machined, using the proper grinding spindle. The edge does not require finishing, however, a 2-3" dia. hole should be drilled in the center. This hole is only used to allow coolant to escape during core grinding. The plate surfaces are only ground enough to clean and keep maximum thickness.

2.6.6 The front and back plate grinding process is identical. The plates are plano-plano ground per 2.6.4. They are, however, ground to a thickness of 2". The seal planes of the boule selected for the surface must be watched and kept in the plate center. The plates are now sagged and returned to finish grind. Procedures in 2.6.5 are followed to grind the surfaces. The customer's finished plates are assumed to be .800" thick. The plates required for sealing must be approximately 1½" thick. With the above in mind, it is imperative to locate the seal planes and calculate the stock removal for each surface of the plate. The plates must have a center hole and the edges ground. The center hole is made by first core drilling a circle of approximately 1" dia. holes. The web between holes is cut using a sand blast unit. This procedure is performed after the first surface is ground and before removing it from the machine to turn over. The inside and outside edges are finished after the second surface is complete and also before it is removed from the machine.

2.0 MAIN TEXT (Cont'd)

2.6.7 Illustrations 7.8.1 through 7.8.2 demonstrate the grinding process.

2.7 E11 Grinding (Struts & Posts)

2.7.1 Posts are .400" square pieces of glass used to form the corners of each cell. A four meter mirror will require 1700 posts. Posts are depicted in Illustration 7.9.

2.7.2 Struts form .200" thick glass rectangles which form the sides of each cell. A hole is drilled in each one to allow the cells to maintain constant external pressure through the mirror when assembled. A four meter mirror will require 3400 struts. Struts are also depicted in Illustration 7.9.

2.7.3 Strut and post manufacture consists of wire sawing the stack formed in 2.4 per Illustration 7.9. The slices are then machined to the proper shapes on surface and edge grinders.

2.7.4 The equipment and technology exist in-house to produce these parts.

2.8 E11 Making

2.8.1 One post and two struts are placed in the vacuum chuck on the e11 making machine. The machine positions the parts properly for sealing. A sequence switch is depressed and the low fire, high fire, and "squash" operations are automatically cycled.

2.0 MAIN TEXT (Cont'd)

2.8.2 The machine used in present production will accommodate the added length of four meter struts. The chucks and burners must be longer, however, so new ones must be designed and built. The design and construction is straightforward and will not pose any problems.

2.8.3 The ell sealing process is depicted in Illustration 7.10. The equipment cost data is in Section 5.4 and the design and engineering requirements are listed in Table 8.3.

2.9 Core Sealing

2.9.1 The core sealing process uses two pieces of major equipment, a takeout table and a core sealer. Modifications of each of these machines are required to produce a core of this size. The cost of these modifications can be found in Equipment Section 5.5. The design and engineering requirements are listed in Table 8.3.

2.9.2 The takeout table consists of a vertical traveler to which a strip of flat glass is fastened. This glass is called a "starter strip" and is the height of the core. Illustration 7.11.1 depicts the takeout table and starter strip. Ells or partial ells are sealed to the "starter strip" to start the core fabrication process. The takeout table moves aft as the core builds.

2.0 MAIN TEXT (Cont'd)

2.9.3 The core sealer consists of a lathe type machine with a carriage which holds and positions the chucks and burners. The ell to be sealed is placed in the chuck. Using the takeout table for in and out positioning and the carriage for crosswise location, the ell is positioned for firing. Illustration 7.11.2 will depict this operation. When the ell is positioned to seal, it forms a square with the adjoining ell. This requires that the burners be movable in the vertical direction because after sealing they are enclosed and must be withdrawn up or down. The vertical movement is provided by an air cylinder on the core sealer. The burners are mounted on the cylinder shaft and in this case move down out of the core. The in and out position, once established, for a row of seals is constant and only the carriage is moved crosswise as the ells are sealed to the core.

2.9.4 The equipment modifications are straightforward and present no problems. The extended burner length does leave a few questions regarding uniform heat distribution from a 28" burner; a development program is recommended to iron out the required new design. The proposed program is found in the Development Section 6.3.

2.10 Ring Manufacturing and Sagging

2.10.1 The flat plates required to build a ring are cut out of a sealed stack. The cut is made by using a wire saw and is depicted by Illustration 7.9.

2.0 MAIN TEXT (Cont'd)

2.10.1 The inner ring is made by sealing four pieces of glass. The outside ring uses 15 or more sections of glass. After slicing the plates from the stack, they are edge and flat ground to the proper size. Holes are core drilled in the plates for pressure stabilization.

2.10.2 The ground plates are placed in a furnace on molds with the proper radius. The furnace is heated and the plates sag to the mold shape (Illus. 7.12).

2.10.3 The grinding and sagging of parts for the four meter ring is routine.

2.11 Ring Sealing

2.11.1 Ring sealing is the operation which seals together the plates in Section 2.10 to form a continuous ring. A special machine is required for this operation. This machine will be made by increasing the size of the present unit. Longer burners are also required for this operation.

2.11.2 Two sections are placed in the machine chucks. The burners are located to concentrate the fire on the section edges. The firing and "squash" actions are cycled and the two sections sealed. The sealed sections are now rotated to align the open edge in the holding chuck or firing position. A new section is placed in the other position. The firing and "squash" sequence is again cycled and three sections of the ring are sealed. This action is repeated until the ring is completed.

2.0 MAIN TEXT (Cont'd)

2.11.3 No significant problems are expected in this operation.

2.11.4 Illustration 7.13 depicts the sealing operation.

2.12 Core Grinding

2.12.1 Core machining consists of lapping, convex grind, concave grind, hole (I.D.) grind, and O.D. grind.

2.12.2 The completed rough core comes off the takeout table sealed to the starter strip. The area next to the starter strip is also a rectangular shape. This is shown in Illustration 7.14.1. The starter strip and the excess core must be removed before the core grinding can proceed. The proper circle is marked on the core and the starter strip and excess core is removed. The core is uneven on the surfaces, thus the lapping process is required to flat one side for chucking.

2.12.3 The lapping operation is required to flatten one side of the core so it can be waxed to the plano-plano wax plate. The procedure is to first place the plano-plano wax plate on the grinder table. The core is suspended over the wax plate, using the "spider." The machine table is rotated at a low speed. Loose abrasive and water is fed onto the wax plate. The core is lowered until light contact is made with the plate. The loose abrasive will remove stock from the core. The process is continued until the core is lapped to the wax plate surface. This process is depicted in Illustration 7.14.2.

2.0 MAIN TEXT (Cont'd)

- 2.12.4 The center hole machining operation consists of plunge grinding down through the core at the proper diameter. The operation is depicted in Illustration 7.14.4. The wheel is offset to the desired hole size.
- 2.15.5 The O.D. is ground to size using an edging wheel and feeding straight down. This operation is shown in Illustration 7.14.4.
- 2.12.6 The convex core grinding is depicted in Illustration 7.14.4 and consists of the following steps: The core is placed on the plano-plano wax plate. The assembly is placed in the anneal kiln and heated. The assembly is then removed from the kiln and wax is melted along the core edges. (Illus. 7.14.3)
- 2.12.6 This wax will flow along the joints and seal the core and wax plate together as the assembly cools. The "waxing" process is a proven and much used process in chucking glass for machining. The assembly is then placed on the contour grinder. The proper template is placed on the machine and the convex radius is machined on the core. The assembly is then removed from the machine and placed back in the kiln. The assembly is again heated to melt the wax, removed from the kiln and the core is lifted from the plate with the "spider." The core is placed in the shipping box and secured. The box is then turned over using the "travel lift." The shipping box is fitted with the necessary hardware

2.0 MAIN TEXT (Cont'd)

2.12.6 to allow this "flopping" operation. This procedure is demonstrated in Illustration 7.14.5. The core grinding operation is conventional with the proper machine and handling equipment. There is no question that this operation will be a success.

2.12.7 The concave grinding operation is a repeat of Section 2.12.4, only the concave-convex wax plate is used to chuck the core (Illus. 7.14.6).

2.13 Cleaning

2.13.1 The front and back plates, core, and inner and outer rings must be carefully cleaned before final assembly. The cleaning operation consists of a degreasing process, an ultrasonic cleaning and, finally, a light acid wash.

2.13.2 The core is lifted using the spider and a jib crane. The core then is suspended in the degreasing tank. The process is continued until the core is free of the wax used in chucking.

2.13.3 The core is next suspended, with the spider, in the ultrasonic tank. This operation is continued until all dirt and grinding residue is removed.

2.13.4 The core again is suspended in a weak HCl solution to remove any residue left from the degreaser. The core is removed and inspected for any foreign material. It is imperative that all foreign material is removed.

2.0 MAIN TEXT (Cont'd)

2.13.5 The procedures in Sections 2.13.2 - 2.13.4 are repeated for the plates and rings.

2.13.6 The cleaning procedure is depicted in Illustration 7.15.

2.14 Sealing

2.14.1 The sealing process consists of assembling the back plate, core, inner and outer ring and front plate. The back plate, core and rings are assembled outside the furnace room to avoid dirt. The assembly is moved to the furnace for the front plate installation.

2.14.2 The fork truck and crossarm arrangement is used to set the back plate on a set of tripods in front of the furnace. The concave side will be up.

2.14.3 The fork truck and spider are used to place the core on the plate. Extreme care must be used to line up the parts properly. It is also important to keep the assembly free of all foreign material.

2.14.4 The inner and outer rings are assembled using the fork truck and ring holders.

2.14.5 The front plate is now placed on the core using the plate handling device. Again care must be taken in aligning of the plate.

2.14.6 The fork truck and crossarm is again used to place the mirror assembly on the furnace tripods. The

2.0 MAIN TEXT (Cont'd)

- 2.14.6 contoured table is moved upward to contact the back plate and lift the assembly from the tripods.
- 2.14.7 A brick fence is constructed between the plates to prevent the face plate from sagging. Walls are constructed around the mirror to retain heat around the assembly. Thermocouples are installed at the required locations. The furnace is closed and the firing cycle is initiated.
- 2.14.8 The mirror is removed from the furnace cooldown, turned over in the packing box, and replaced in the furnace for second side firing. The furnace table must be rebuilt convex for the second firing. Sections 2.14.5 - 2.14.6 are repeated in 2.14.7. (Illus. 7.16.1 - 7.16.2)

2.15 Annealing

- 2.15.1 Annealing is the process which removes any thermal stress left in the glass after sealing operations. The procedure is to heat the part, or parts, to a temperature above the strain point, hold until the contents of the furnace are stabilized thermally, and cool slowly down through the strain point. This cooling rate determines the degree of stress removal.
- 2.15.2 The annealing operation is performed in a large kiln which has been designed to produce even heating and low temperature gradients inside the furnace. The present kiln used for space telescope and other

2.0 MAIN TEXT (Cont'd)

2.15.2 Large mirror programs has performed well. To accommodate the four meter mirror, it must be enlarged in all three dimensions. The enlargement can be accomplished. The services (gas and air) are adequate, thus by enlarging the kiln, annealing can be accomplished.

2.15.3 The cost to enlarge the annealing kiln is outlined in 5.10.1.

3.0 CONCLUSIONS

- 3.1 The batch preparation, all grinding (posts and struts) and ring segment manufacture are capabilities which now exist in the plant. They do not require new equipment nor do they incur additional costs.
- 3.2 The strut stack sealing, plate sagging, mirror sealing, ring sealing and annealing processes require that present equipment must be enlarged to handle the four meter size. They also require that special handling equipment be purchased or constructed to move the large parts and assemblies.
- 3.3 The plate and core grinding operations require the purchase of a new machine. The machine is available from a commercial source. The handling equipment mentioned in Section 3.2 is also required.
- 3.4 The ell making and ring sealing require new and longer burners. They also require minor modifications to the present machines.
- 3.5 The present cleaning equipment, consisting of three tanks, must be enlarged to accommodate the increase in diameter. The existing jib crane is adequate to handle the increased weight.
- 3.6 Core sealing and plate flowout do require development programs.
 - 3.6.1 The core sealing program is chiefly to test out the longer burners. The development program is expected to produce positive results without too much difficulty.

3.0 CONCLUSIONS (Cont'd)

3.6.2 Plate flowout represents the most serious problem in fabricating a 4 meter mirror. Two approaches are possible:

3.6.2.1 Development of 100" diameter 2400 lb. boule production is recommended as best approach to problem.

3.6.2.2 Flowout of 60" boules with special additional flows to flatten seal planes is offered as an alternative. This approach needs a flowout experiment to verify the ability to flatten seal planes.

3.6.3 The above programs will result in two wax plates 4 meters in diameter that will be needed for the program.

3.7 Corning Glass Works concludes that construction of a ULETM 4 meter diameter lightweight mirror blank in the manner described and fusion sealed can be accomplished, with a high probability of success.

4.0 RECOMMENDATIONS

- 4.1 The development program to produce quality 100" diameter, 2400 lb. boules should have the highest priority. The lead time to get a furnace of this size into operation is 17 months. The larger boule will become a reducing cost factor if successful due to a lower number of flowouts to produce a plate. One wax plate will result from this program.
- 4.2 A program to study the flowout of 60" dia., 1300 lb. boules to 4 meters should also be done. The purpose of this program will be to get the seal planes appropriately located. Another required wax plate will result from this program.
- 4.3 The success of ell, ring and core sealing are dependent on a new, longer burner. A design concept has been completed. This design should be finalized and burners made to test out the design.

5.0 EQUIPMENT

5.1 Laydown Furnace for 2400 lb. Boule

5.1.1	Furnace	\$150,000
5.1.2	Burners	15,000
5.1.3	Material	6,000
5.1.4	Labor	5,000
5.1.5	Furnace Room 4 Refurbishment	112,000
5.1.6	Fan and ductwork	<u>85,000</u>

Total \$373,000

5.2 Plate Sagging

5.2.1	Forming template - 80 hrs. machinist	\$ 1,000
5.2.2	Forming template material	340
5.2.3	Mold - 180 hrs. mason	1,905
5.2.4	Mold material	<u>2,570</u>

Total \$ 5,815

5.3 Mirror Component Grinding

5.3.1	Machine	\$300,000
5.3.2	Machine Installation	10,000
5.3.3	Plant changes	<u>1,535</u>

Total \$311,535

5.4 EII Making

5.4.1	Burners	\$ 5,304
5.4.2	Chucks	9,165
5.4.3	Strut support	3,980
5.4.4	Installation	<u>864</u>

Total \$19,313

5.0 EQUIPMENT (Cont'd)

5.5 Core Sealing

5.5.1	Burners and holders	\$ 22,216
5.5.2	Chuck and positioner	8,000
5.5.3	Air Cylinder and mount	5,650
5.5.4	Alterations to core sealer	7,820
5.5.5	Alterations to takeout table	<u>4,590</u>
	Total	\$ 48,276

5.6 Ring Sealing

5.6.1	Enlarge table	\$ 2,970
5.6.2	Ring holding device	605
5.6.3	Ring handling device	1,350
5.6.4	Plant changes	1,050
5.6.5	Burners (2)	<u>11,108</u>
	Total	\$ 17,083

5.7 Cleaning

5.7.1	Enlarge degreaser	\$ 8,169
5.7.2	Enlarge ultrasonic	4,495
5.7.3	Material	1,100
5.7.4	Acid rinse tank	<u>300</u>
	Total	\$ 14,064

5.8 Sealing

5.8.1	Burners	\$ 15,060
5.8.2	Panels	34,080
5.8.3	Brick and block	9,800
5.8.4	Steel and mill supplies	2,100
5.8.5	Labor	15,950
5.8.6	Mold template	<u>1,340</u>
	Total	\$ 78,330

5.0 EQUIPMENT (Cont'd)

5.9 Handling Equipment

5.9.1	Fork truck	\$ 82,055
5.9.2	Cross arm and forks	2,200
5.9.3	Spider	3,600
5.9.4	Packing box and tripods	17,500
5.9.5	Plate handling device	700
5.9.6	Misc. hardware	<u>650</u>
	Total	\$106,705

5.10 Annealing

5.10.1 Enlarge kiln \$ 27,085

Equipment cost \$1,001,206

Handling charge 10% x 1,001,206 = 100,120

Total cost \$1,101,326

6.0 DEVELOPMENTS

6.1 2400 lb. Boule Development

6.1.1	10 runs @ 2 weeks/run	\$296,600
6.1.2	200 engineering hours	
6.1.3	400 technician hours	
6.1.4	75% of glass produced will be used in other phases of the program.	
6.1.5	Equipment and plant changes are included in Section 5.	

6.2 Flowout Development Using 1300 lb. Boules

6.2.1	2 flowout runs @ \$316,149	\$632,298
-------	----------------------------	-----------

6.3 Core Sealing Development

6.3.1	Operator - 50 hours	5,300
6.3.2	Technician - 50 hours	
6.3.3	Engineer - 20 hours	
6.3.4	100 ells @ \$402.11	40,211
6.3.5	Starter strip (partial)	<u>6,006</u>

6.4 Total Development Cost

6.4.1		\$980,415
-------	--	-----------

Cost

\$1,470,500

6.5 Engineering hours indicated in 6.1 and 6.3 are costed in 8.3 (manpower).

7.1 PLATE THICKNESS VS. STRESS

46 0703

K-E 10 X 10 TO THE INCH .7 X 10 INCHES
 HERTZEL & COMPANY CO. MADE IN U.S.A.

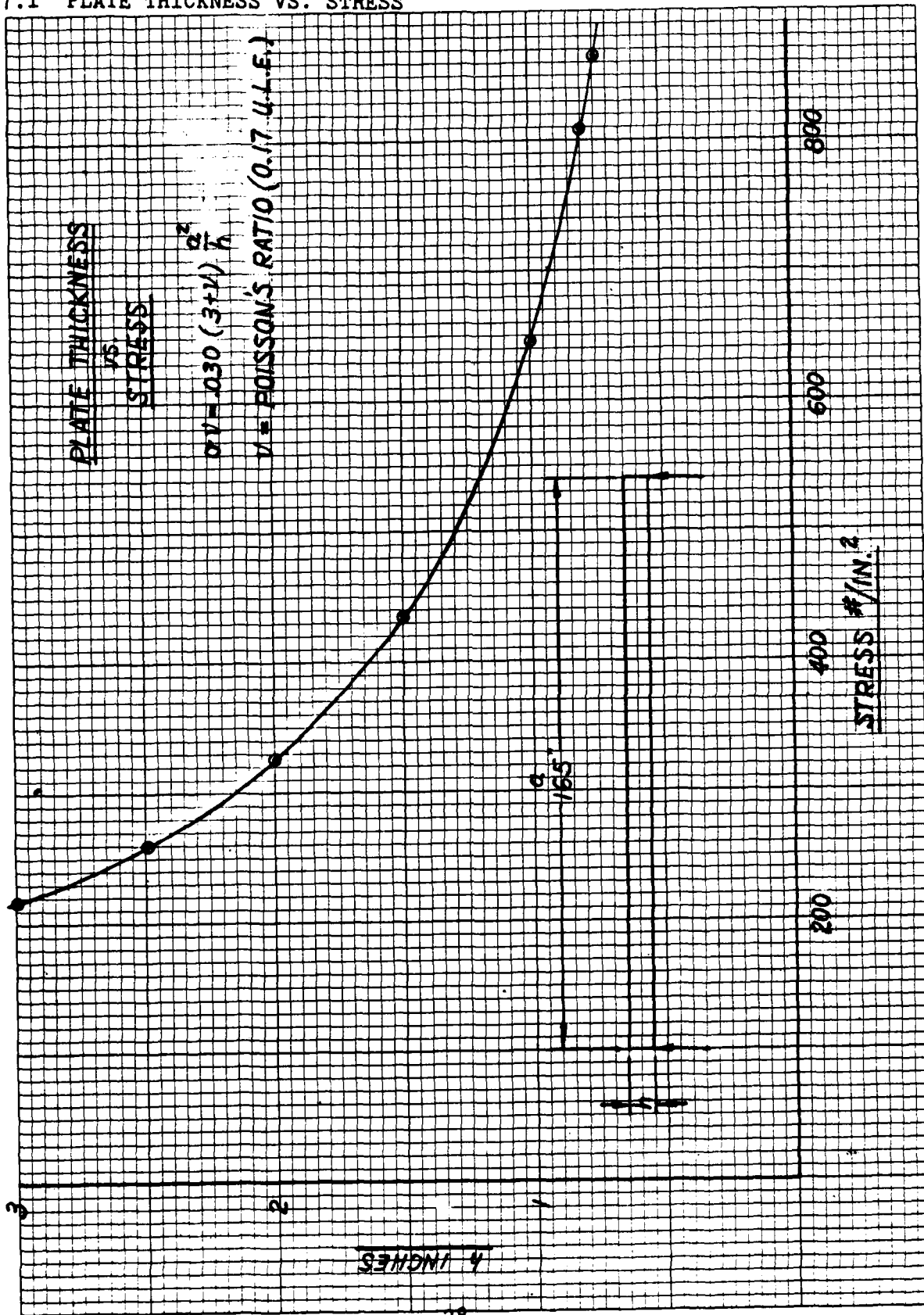

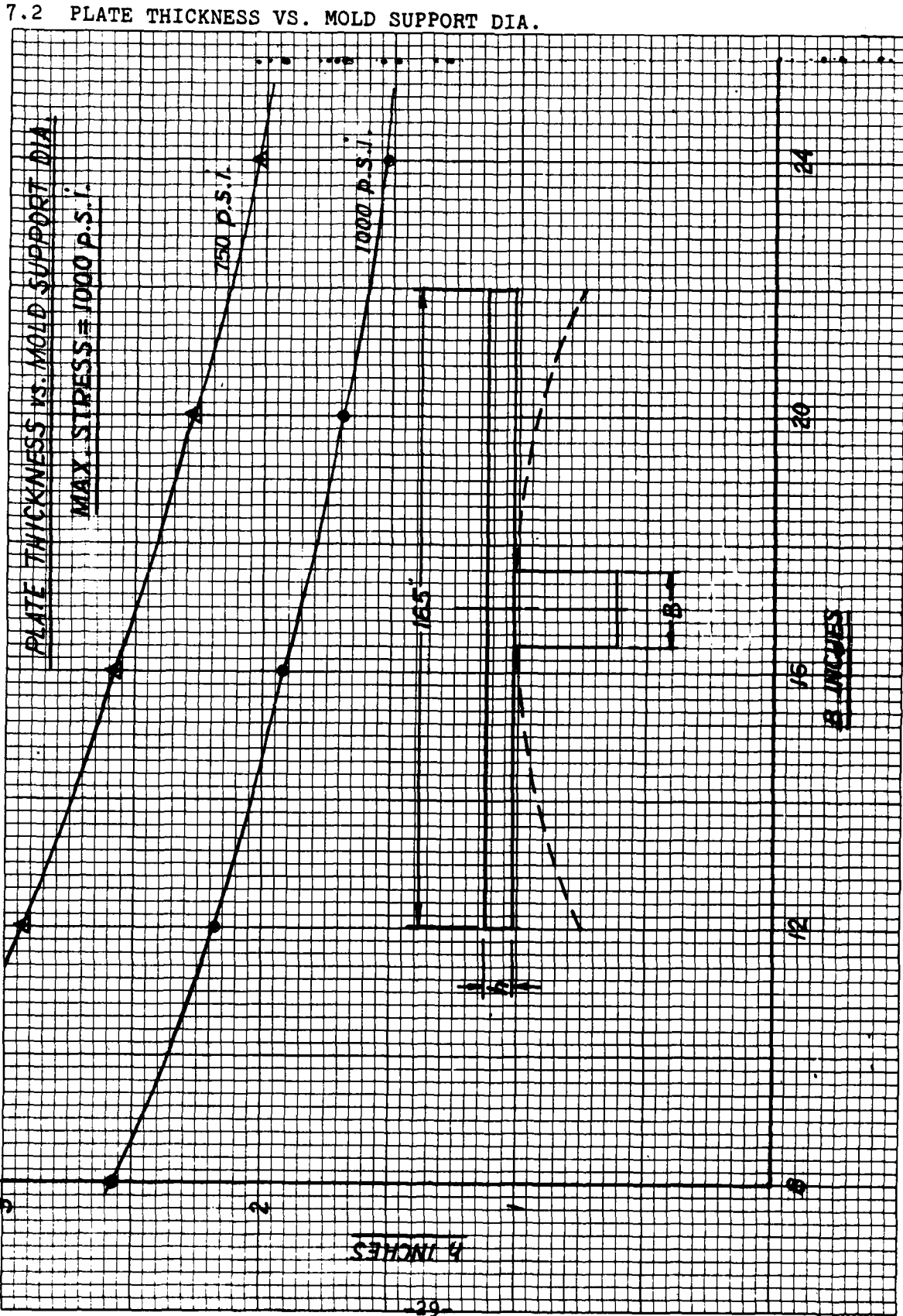

7.3 DEFLECTION ($W_{(0)}$) VS. THICKNESS (h)

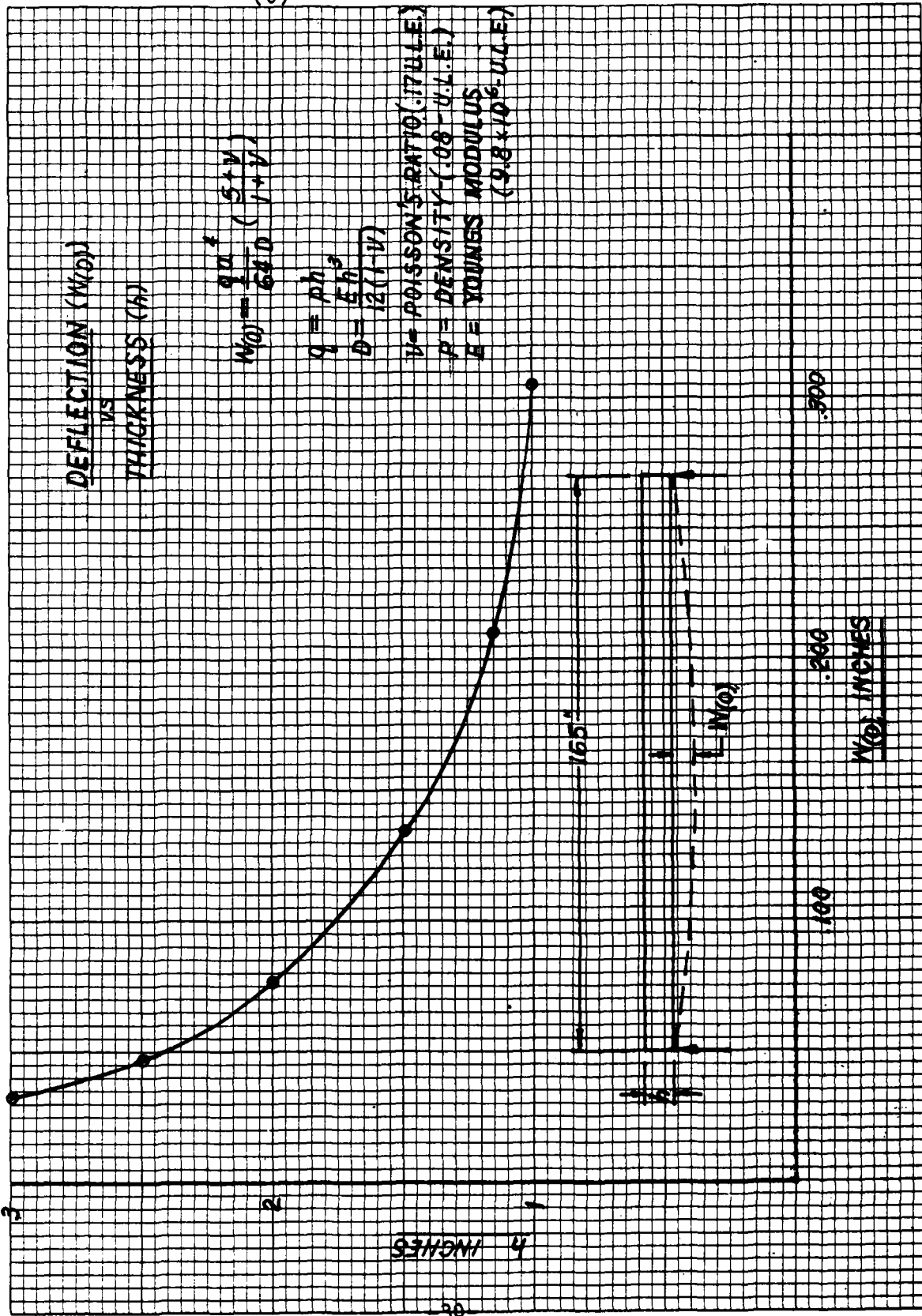

7.4 STACK SEALING

7.4.1 Assembly

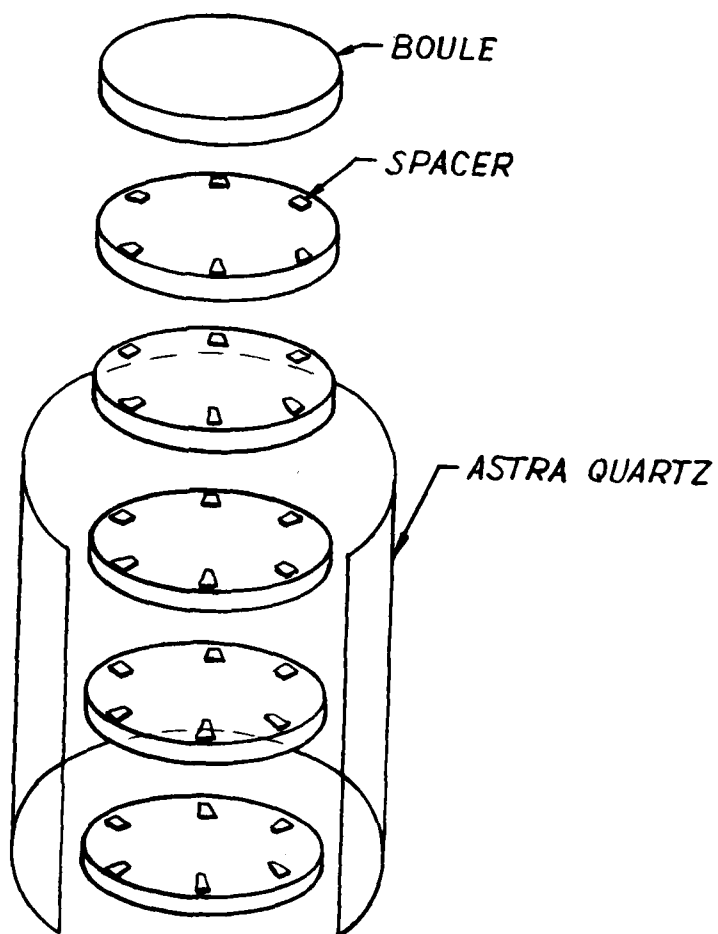

7.4 STACK SEALING (Cont.)

7.4.2 Furnace Loading

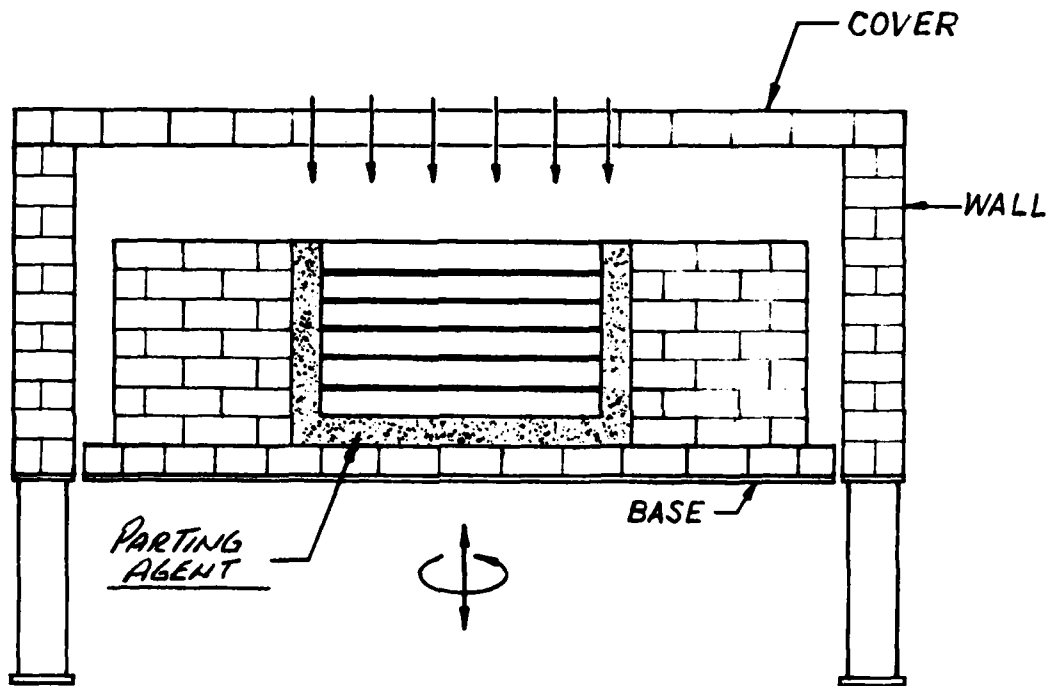

7.4 STACK SEALING (Cont.)

7.4.3 Finished Stack

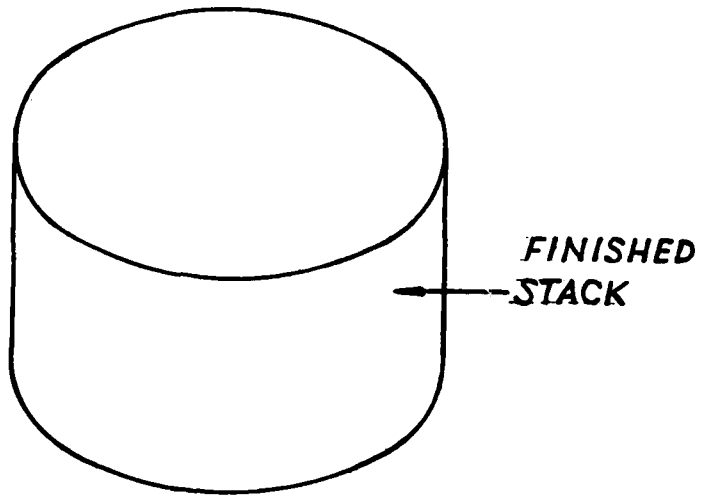

7.5 FLOWOUT (1300 Lb. Boule)

7.5.1 1-4 Flowouts

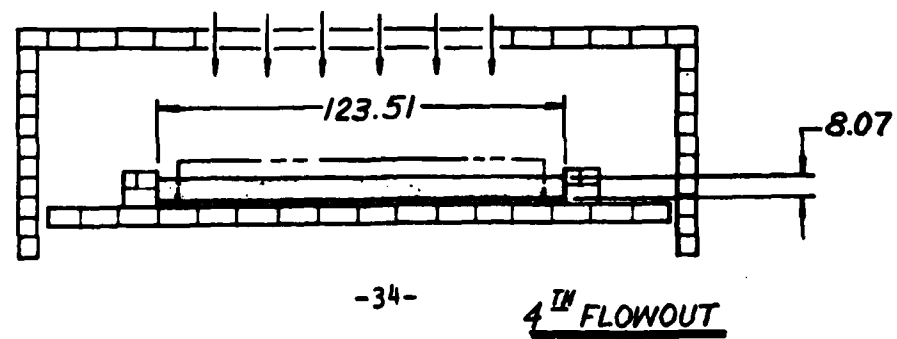
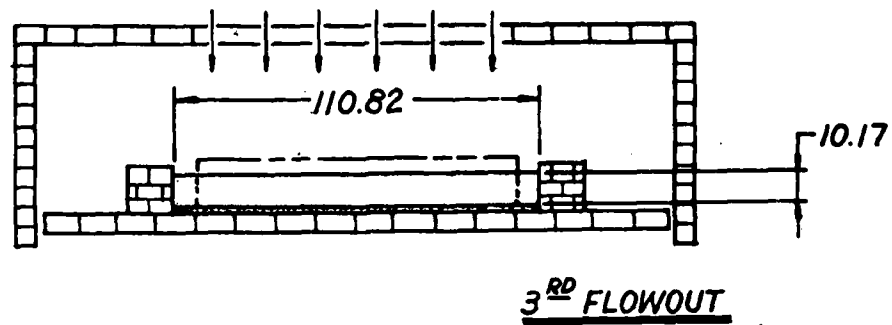
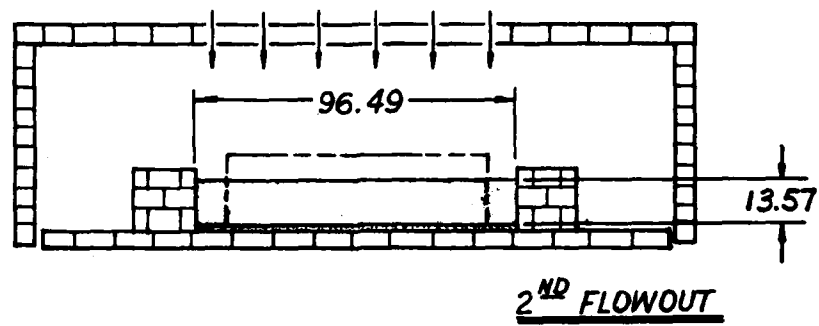
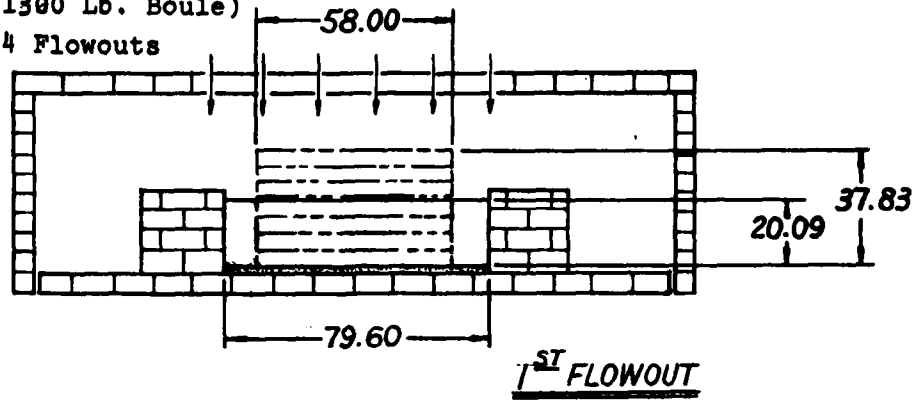

7.5 FLOWOUT (1300 Lb. Boule)

7.5.2 5-8 Flowouts

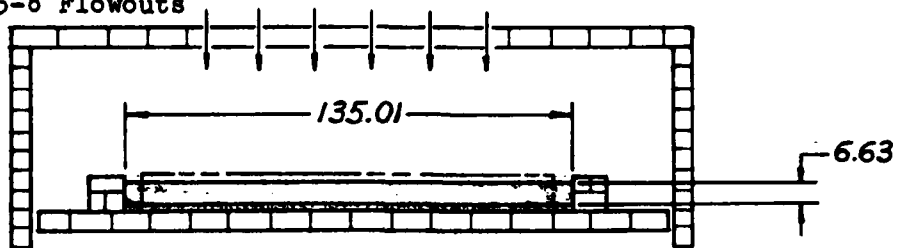

5TH FLOWOUT

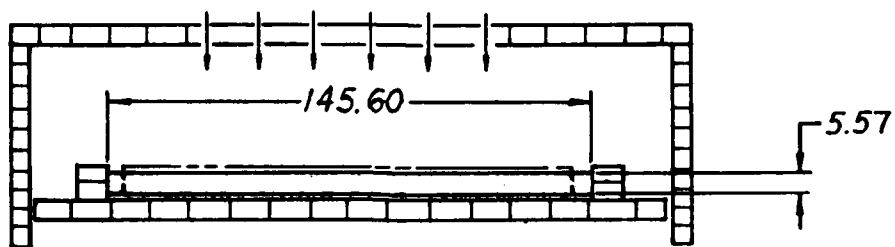

6TH FLOWOUT

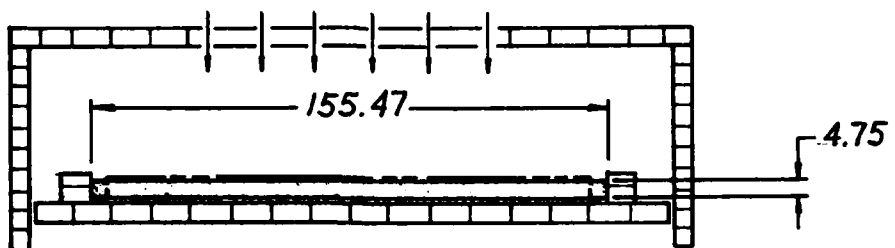

7TH FLOWOUT

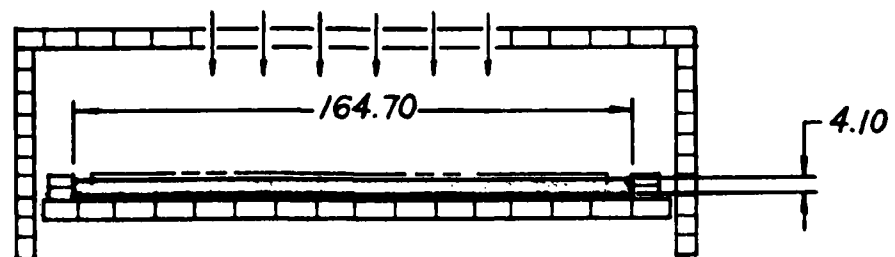

8TH FLOWOUT

7.5.3 Flowouts 1-4 (2400 Lb. Boule)

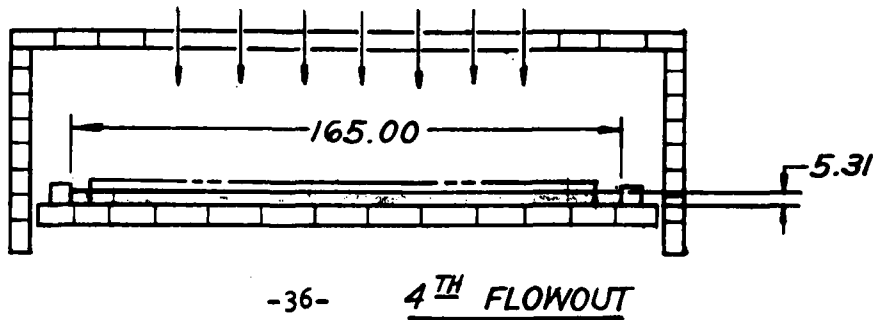
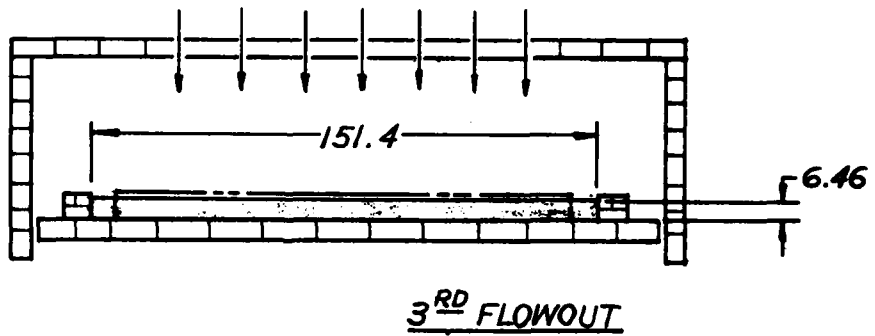
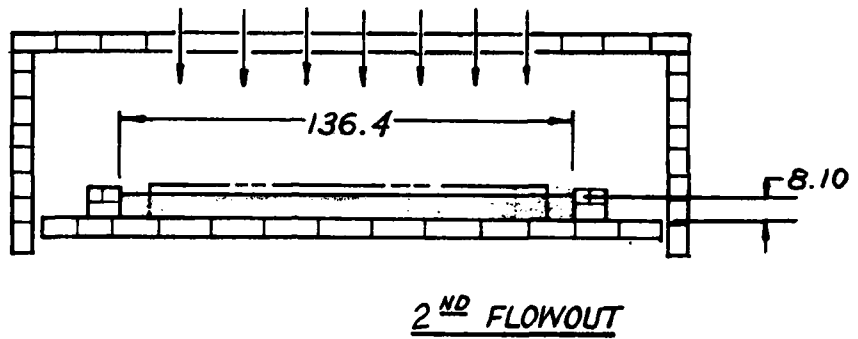
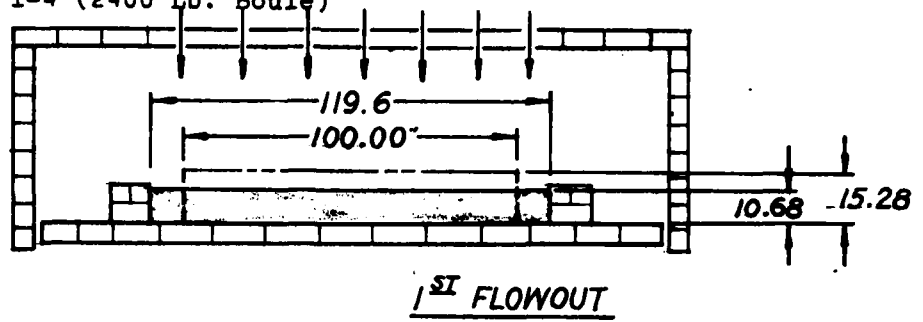

7.6 SAG MOLD MAKING

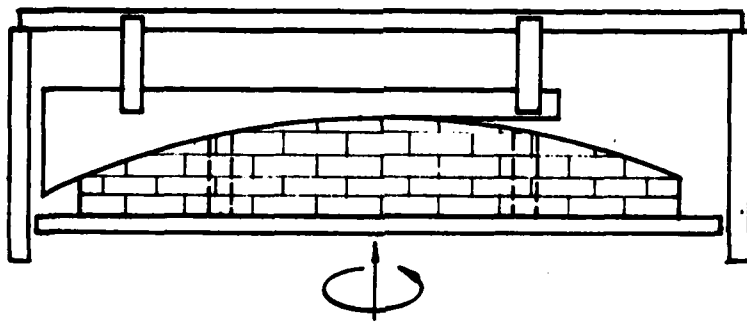
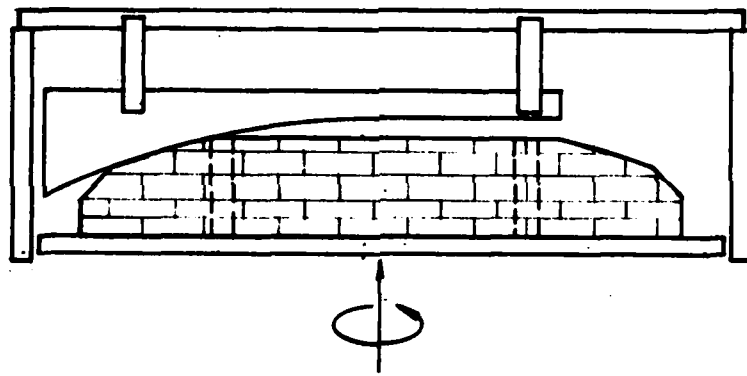
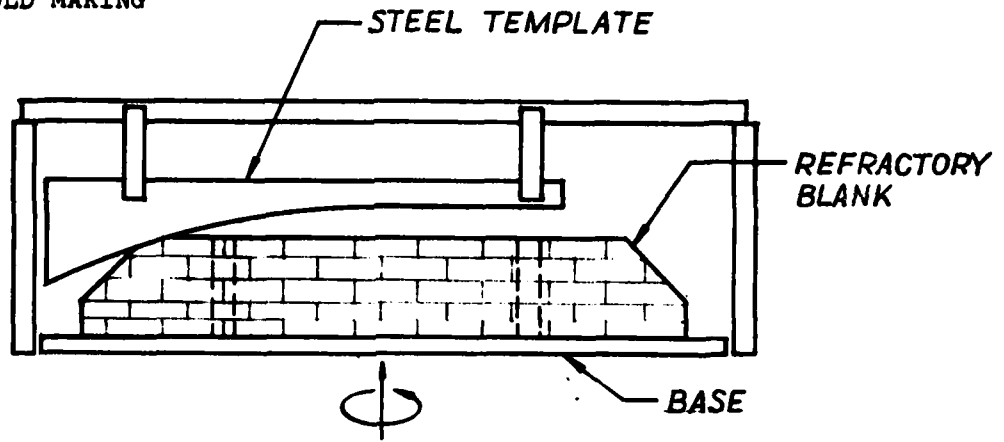

7.7 PLATE SAGGING

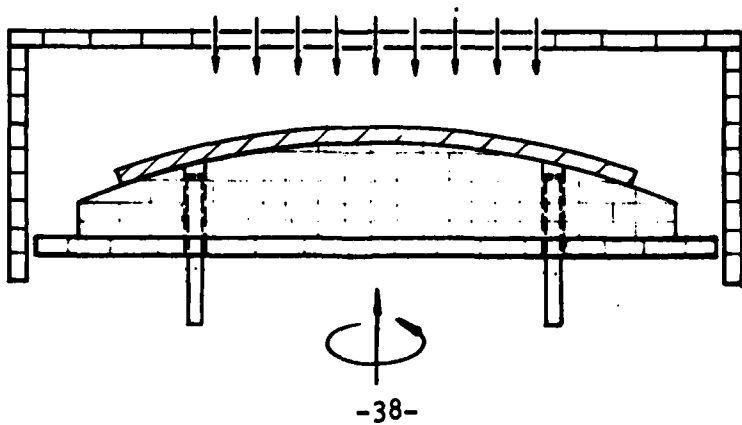
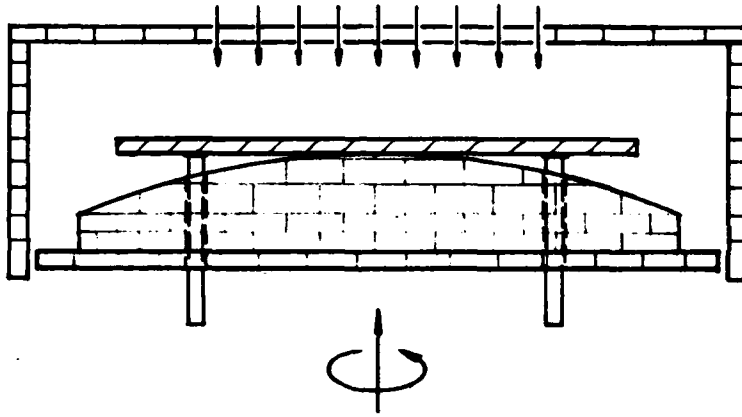
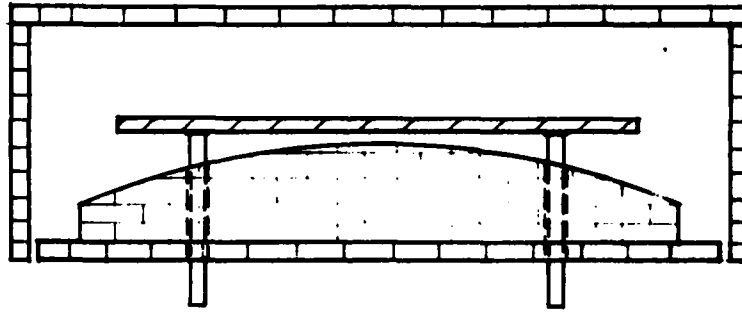

7.8 PLATE GRIND

7.8.1 Plano-Plano Grind

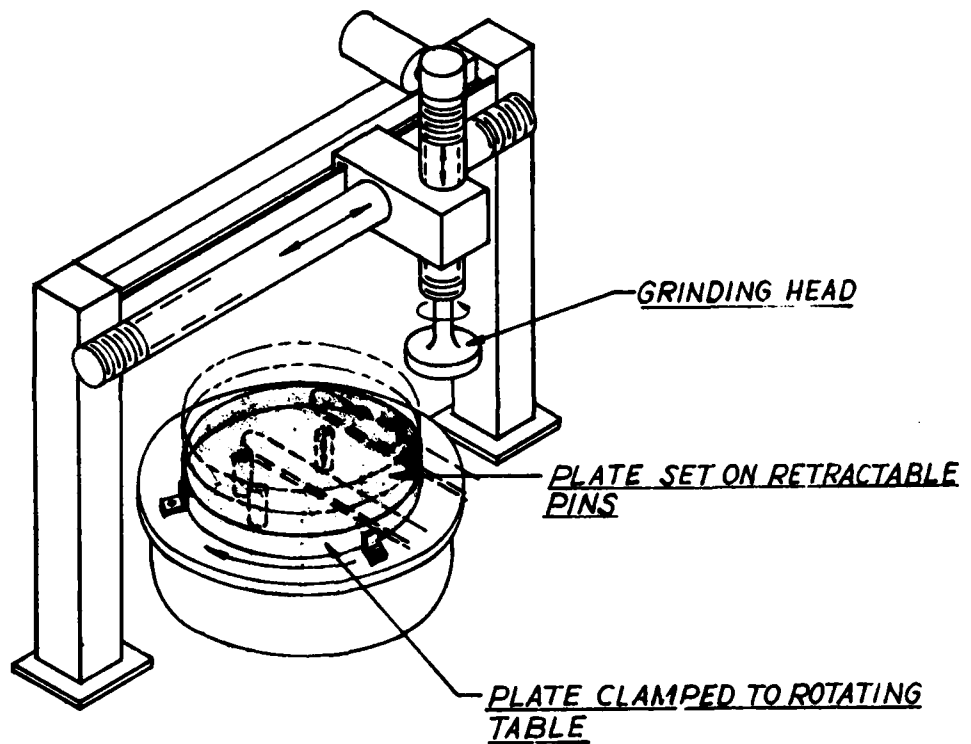

7.8 PLATE GRIND (Sheet 2)

7.8.2 Concave-Convex Plate Grind

RETRACTABLE PIN

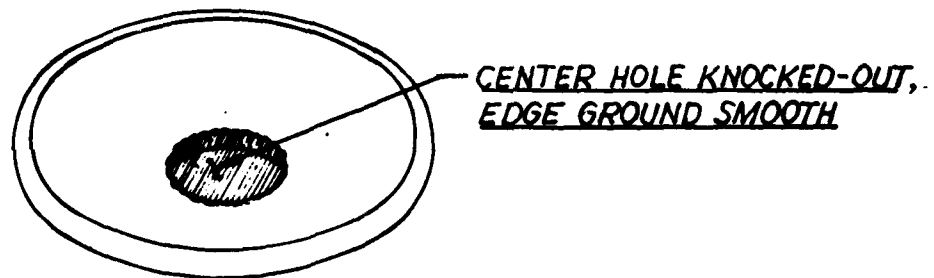
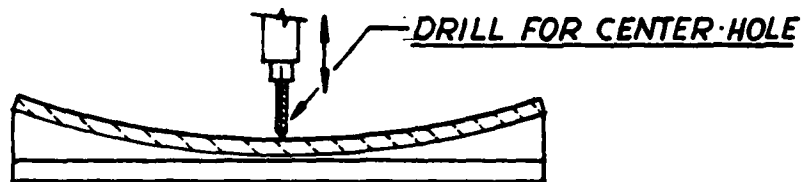
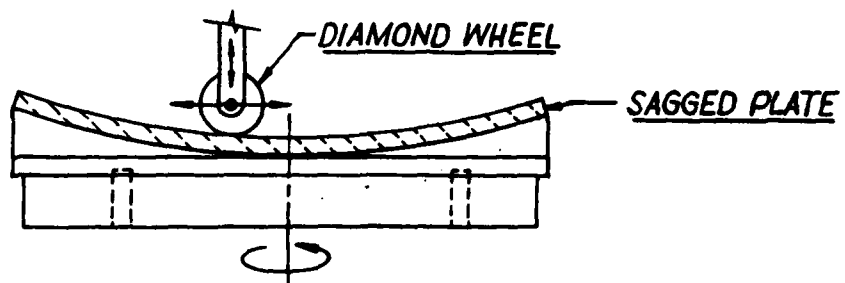
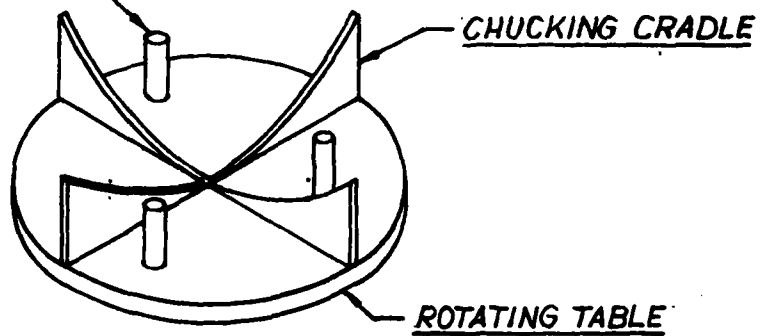

7.9 ELL GRINDING (POSTS AND STRUTS)

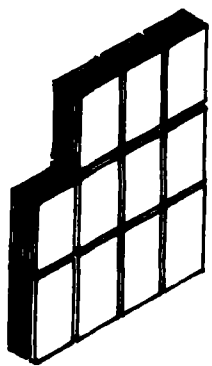
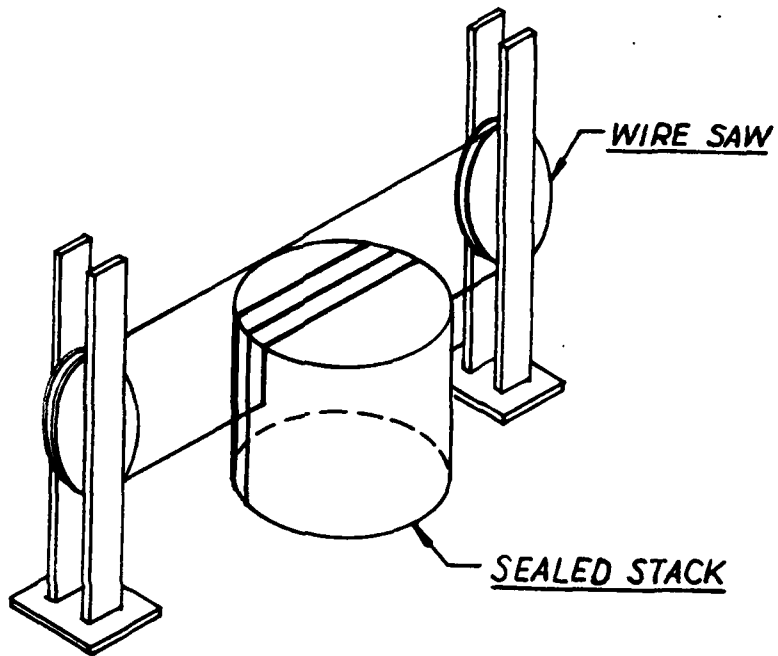

STRUTS

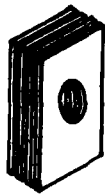

POSTS

7.10 ELL MAKING

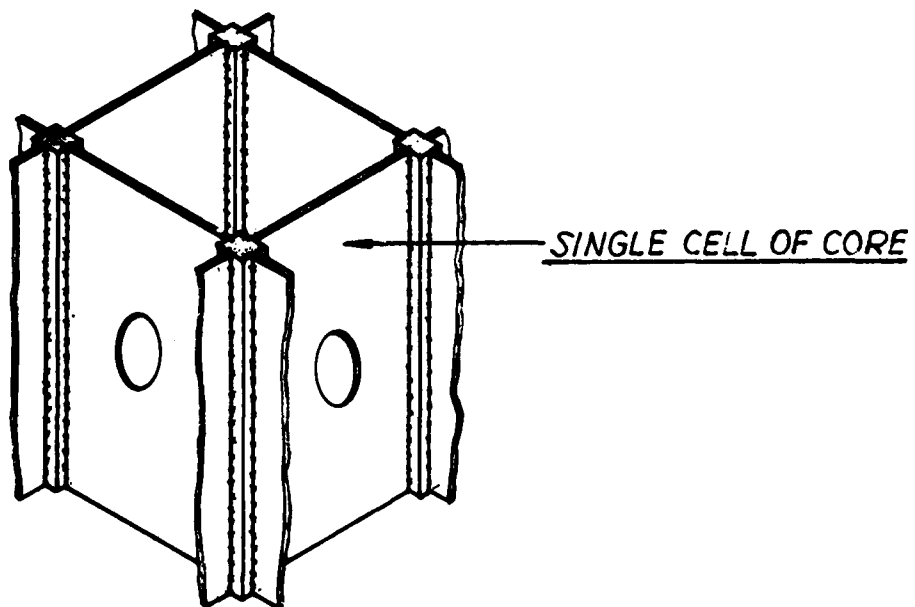
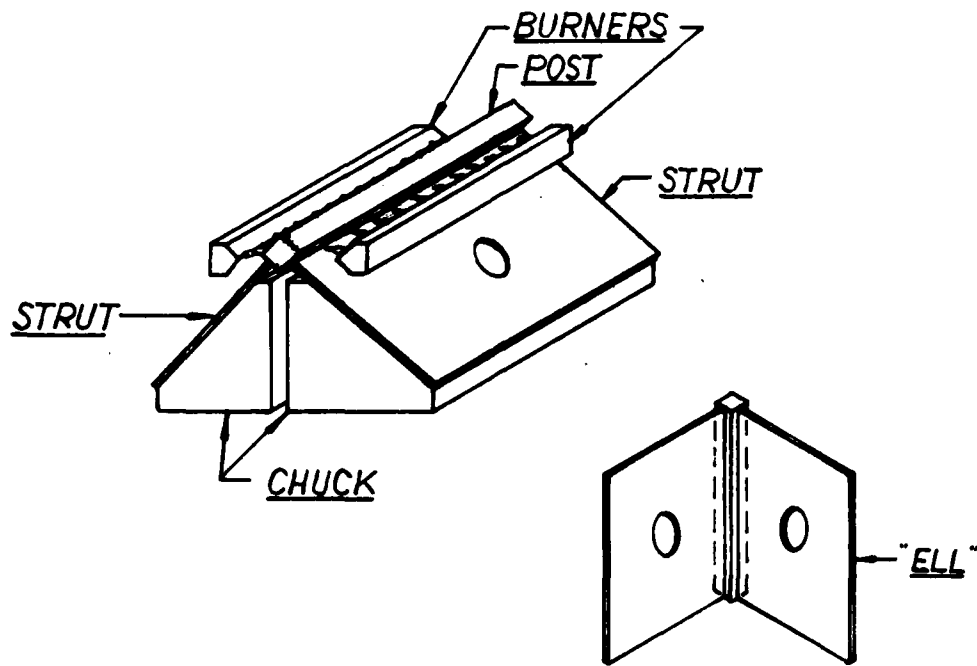

7.11 CORE SEALING

7.11.1 Takeout Table

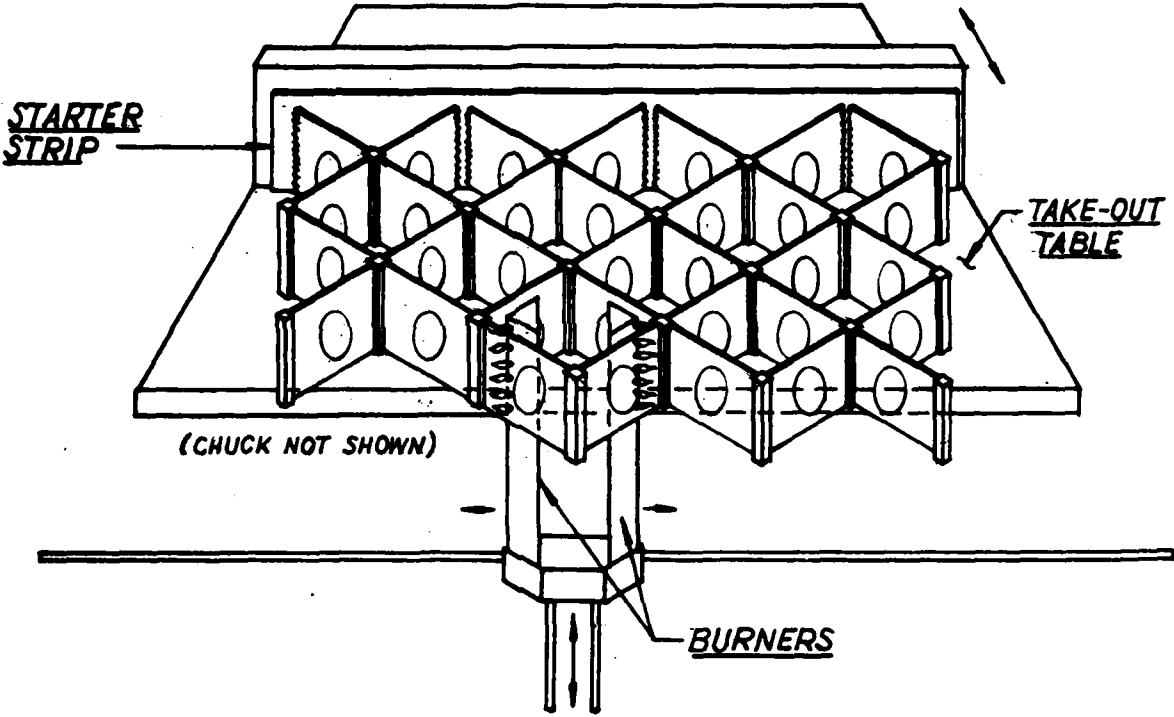

7.11.2 Core Sealer

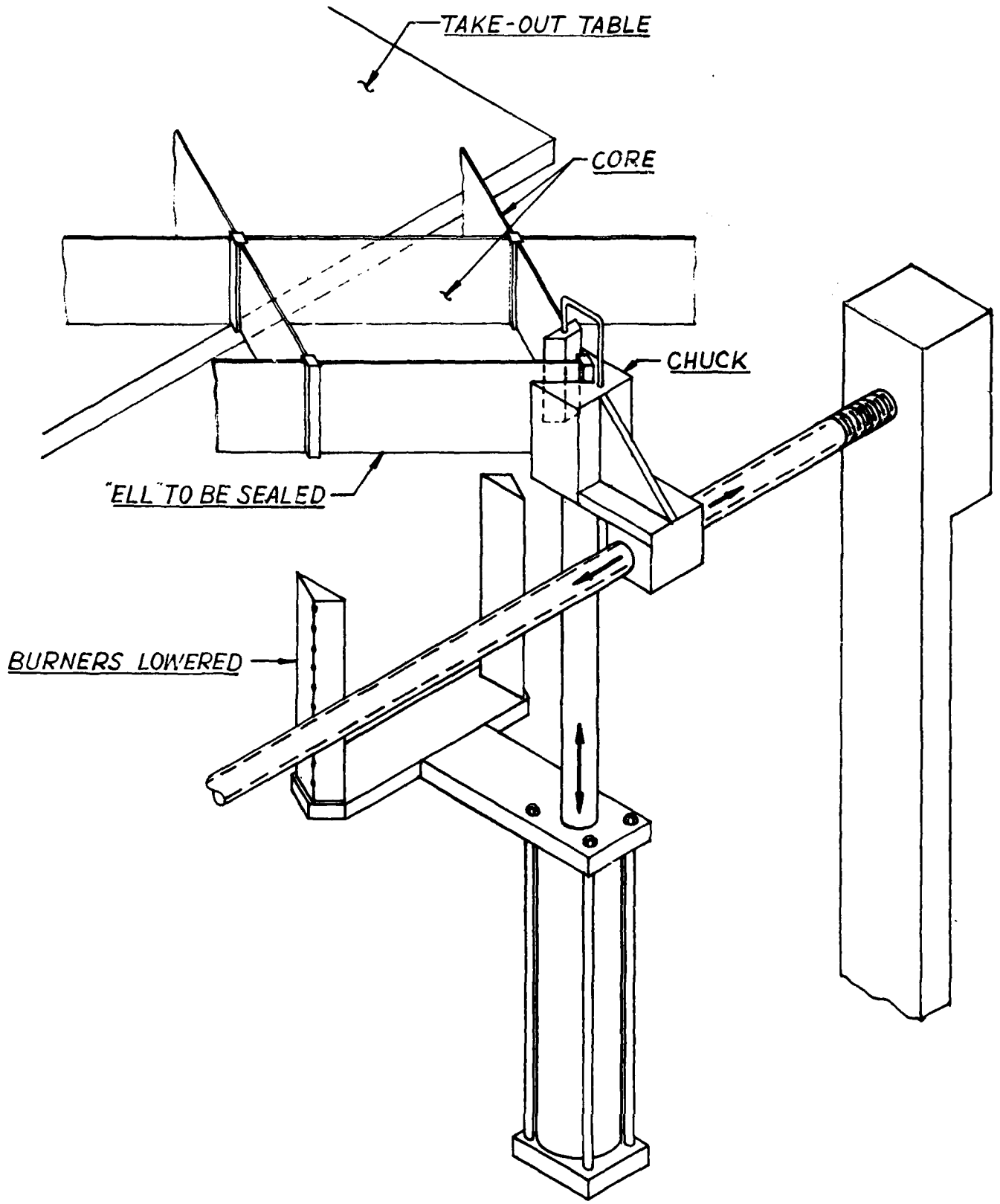

7.12 RING SEGMENT SAGGING

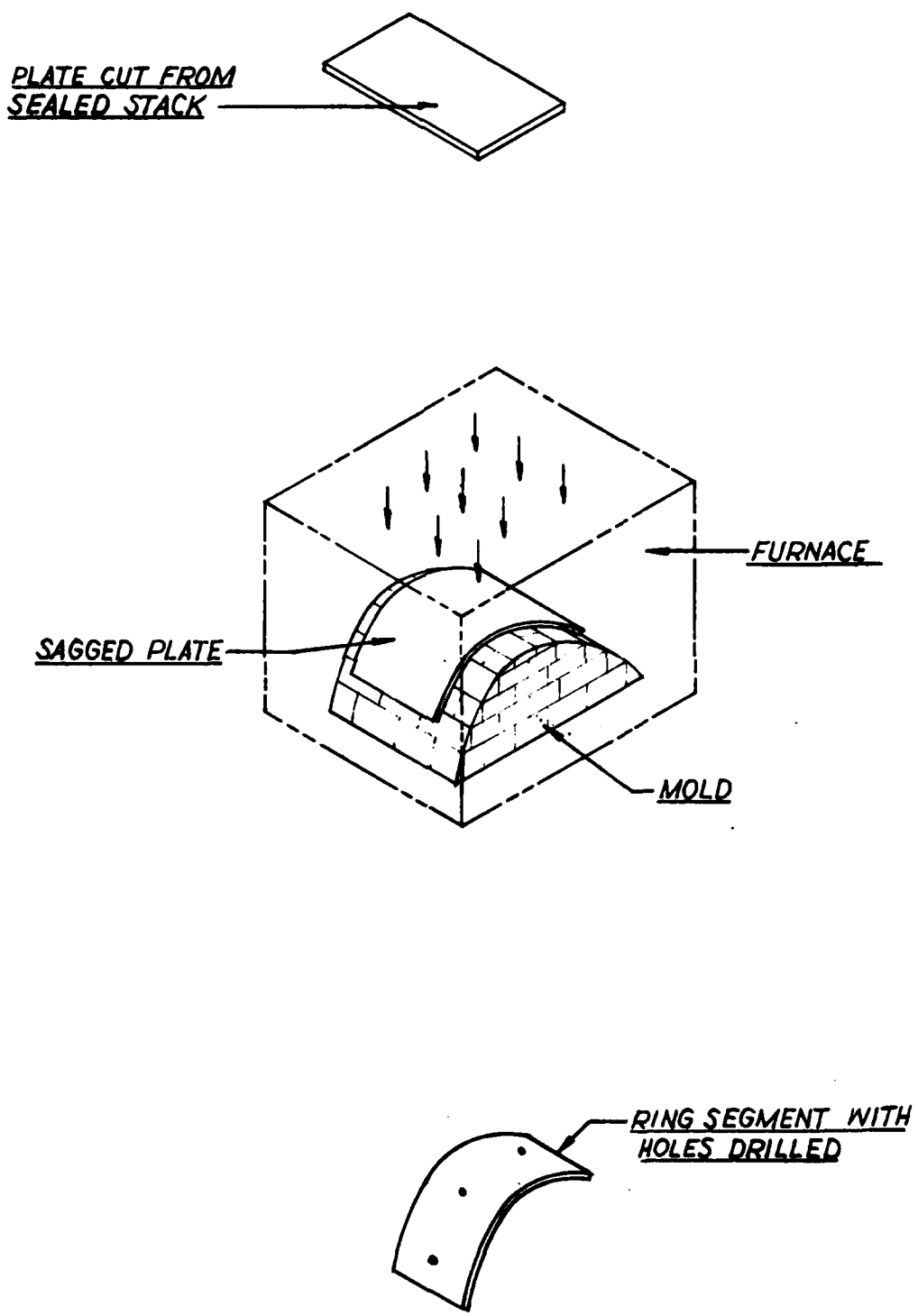

7.13 RING SEALING

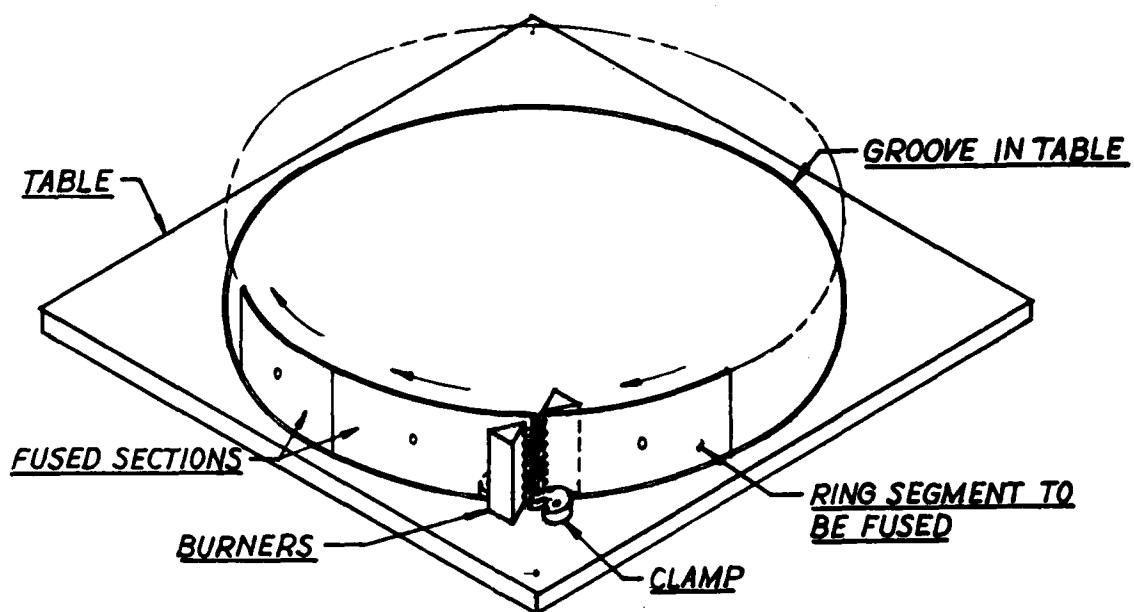

17.14 CORE GRINDING

17.14.1 Rough Core

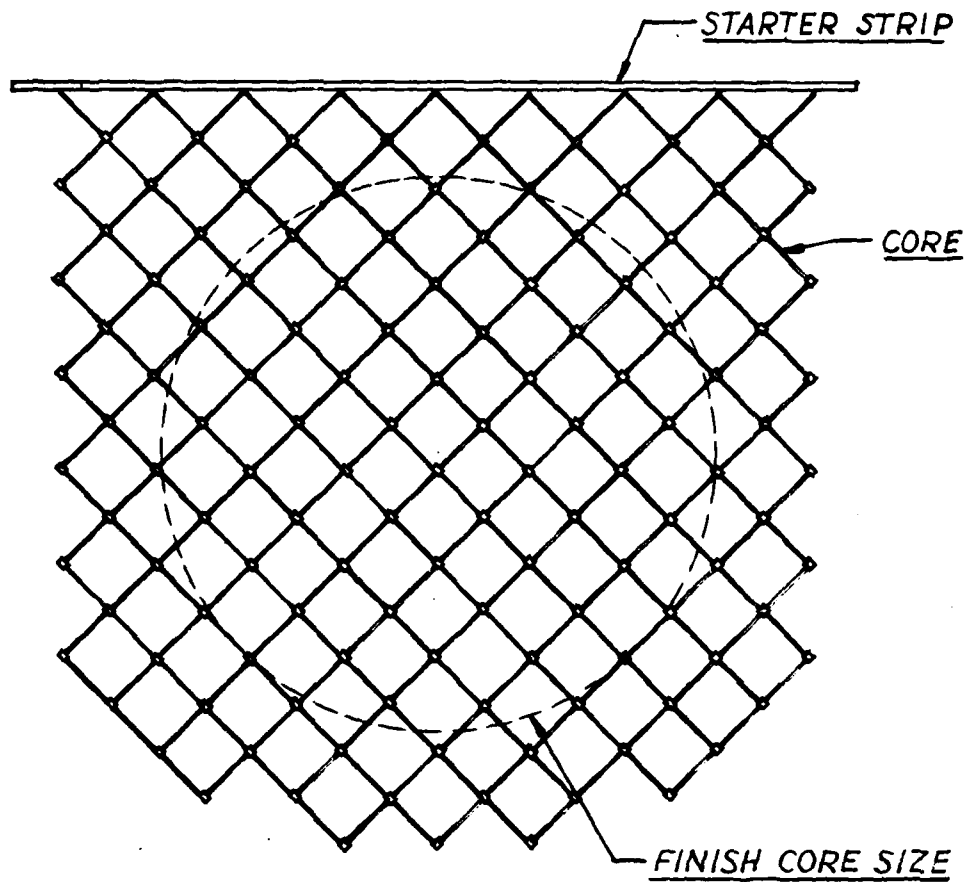

7.14 CORE GRINDING

7.14.2 Core Lapping

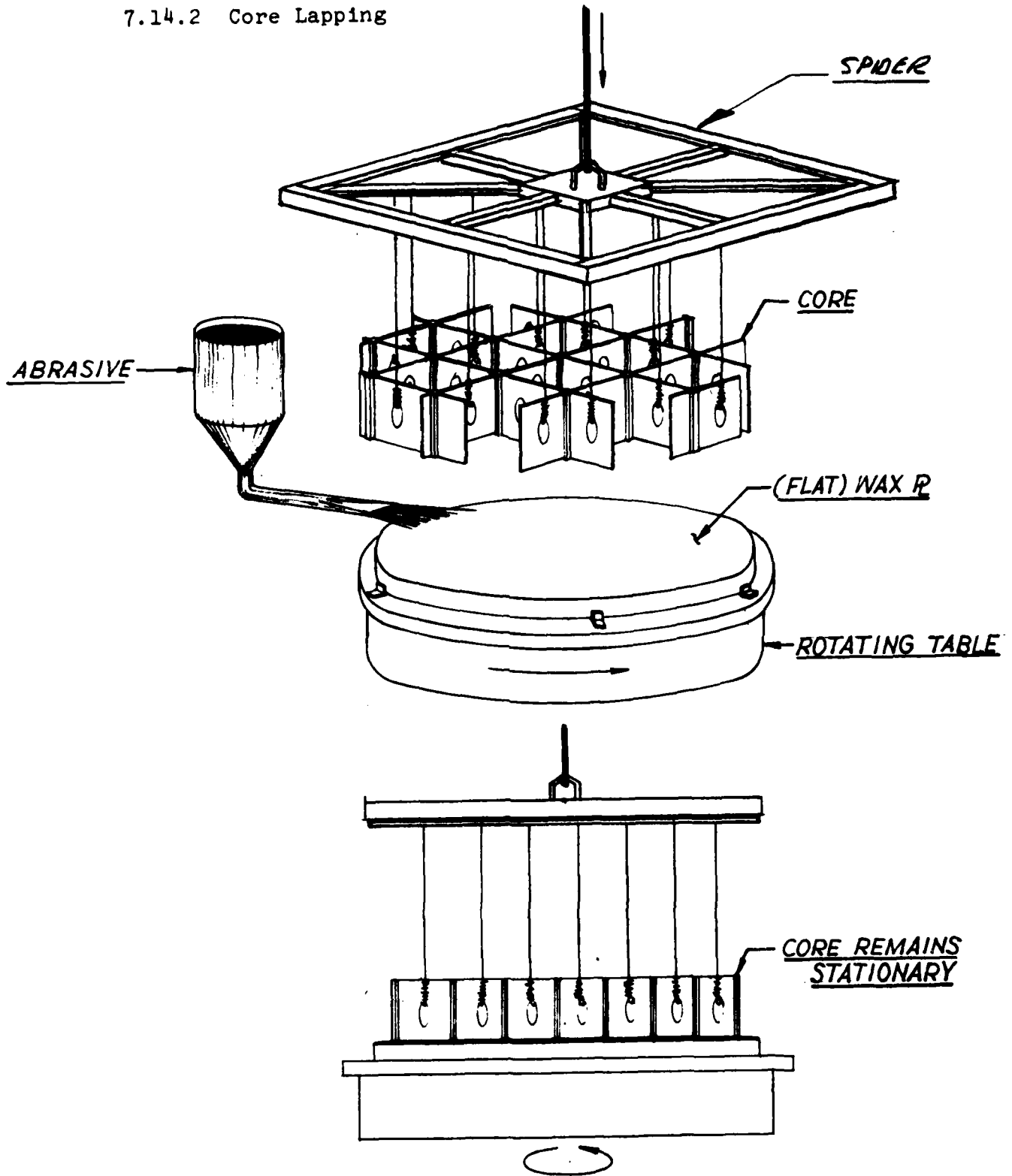

7.14 CORE GRINDING

7.14.3 Core Chucking

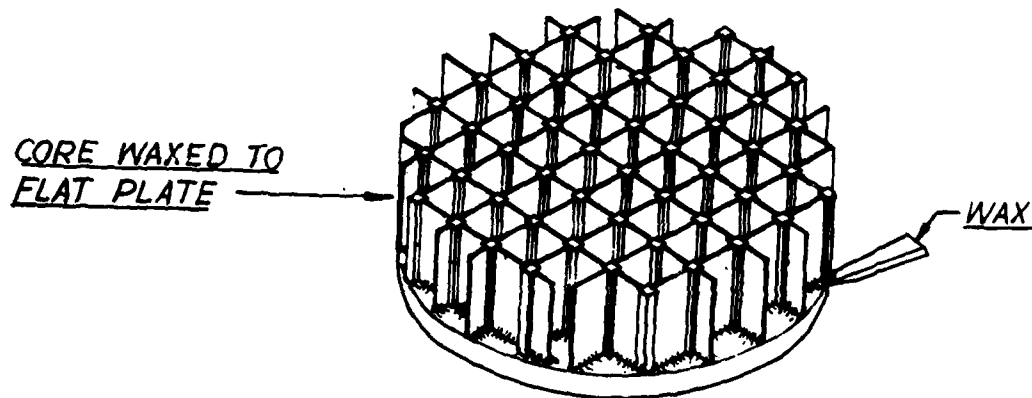
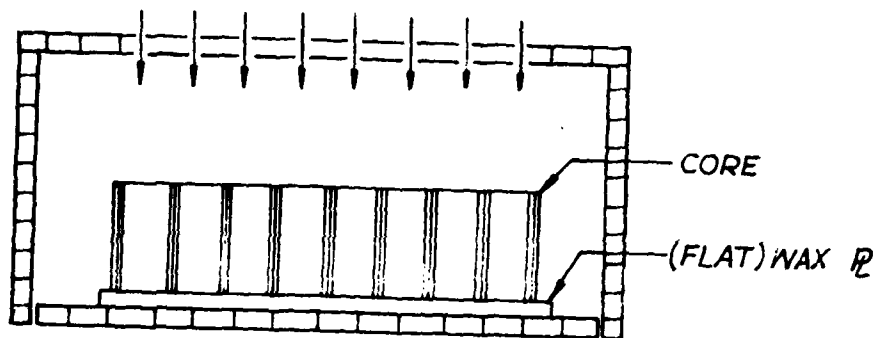

7.14 CORE GRINDING

7.14.4 Core Grinding-Convex Side

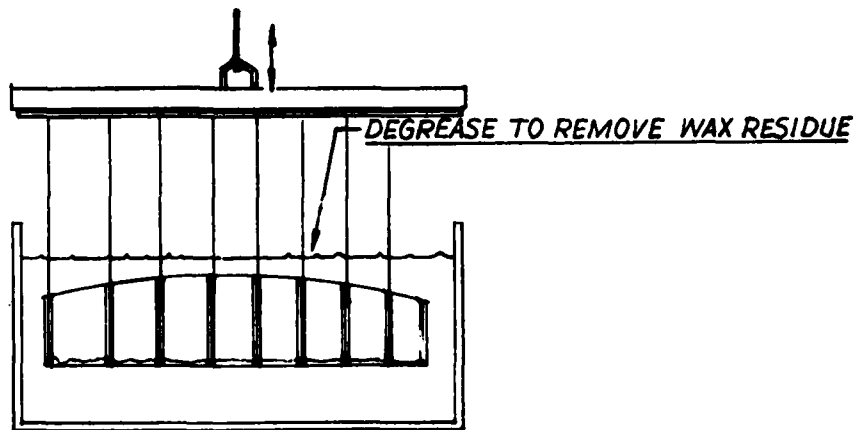
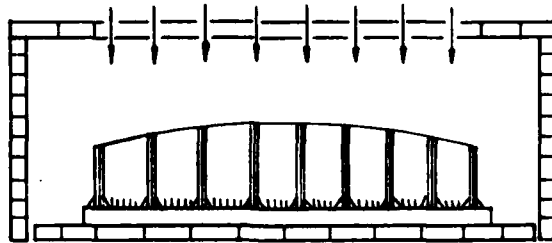
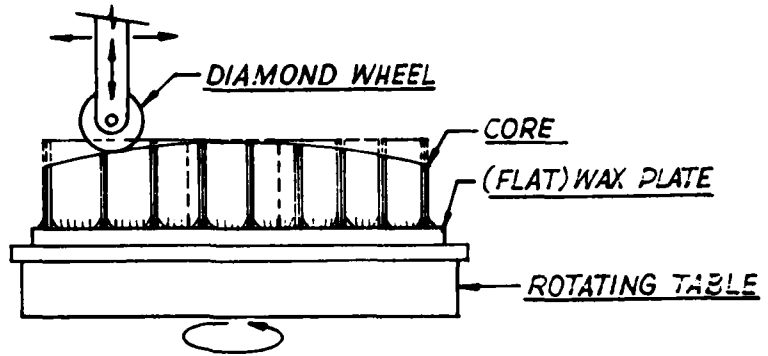
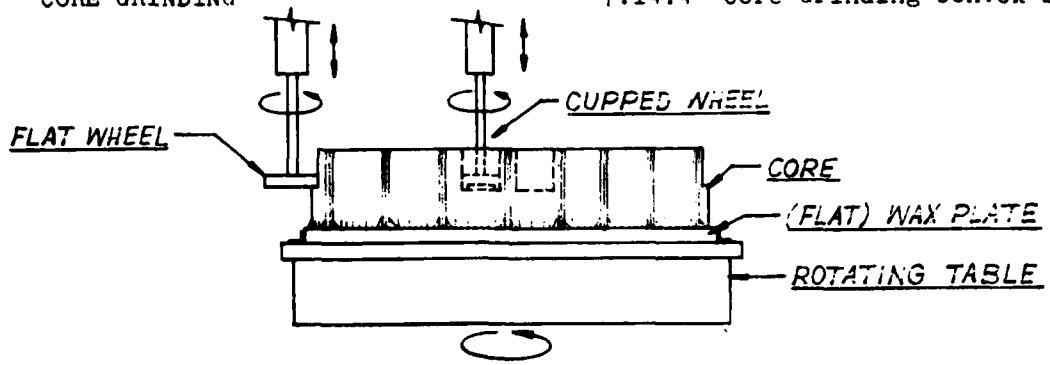

7.14 CORE GRINDING
7.14.5 Core Flopping

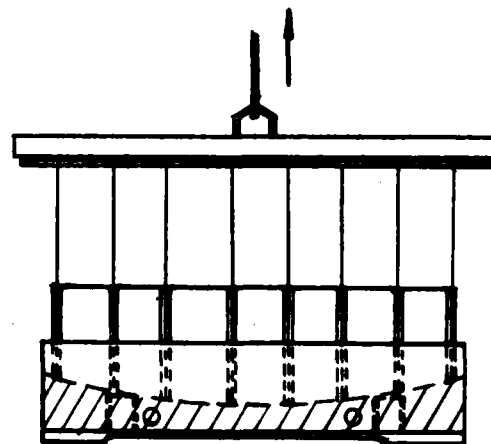
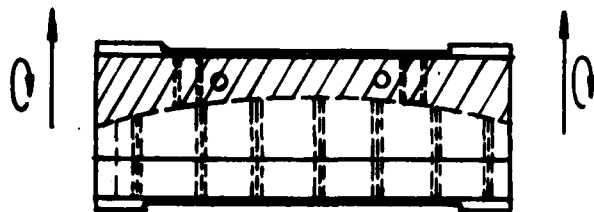
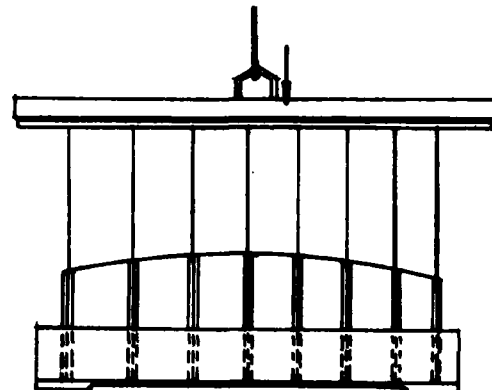
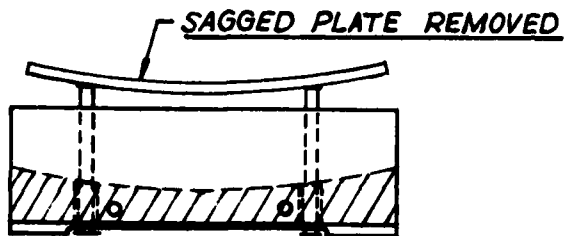
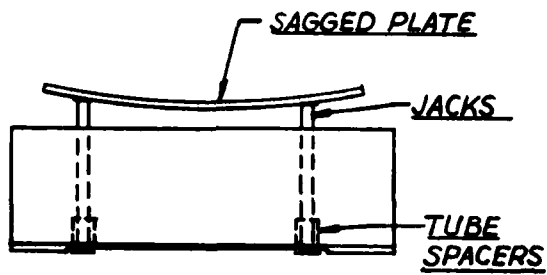

7.14 CORE GRINDING

7.14.6 Core Grinding Concave Side

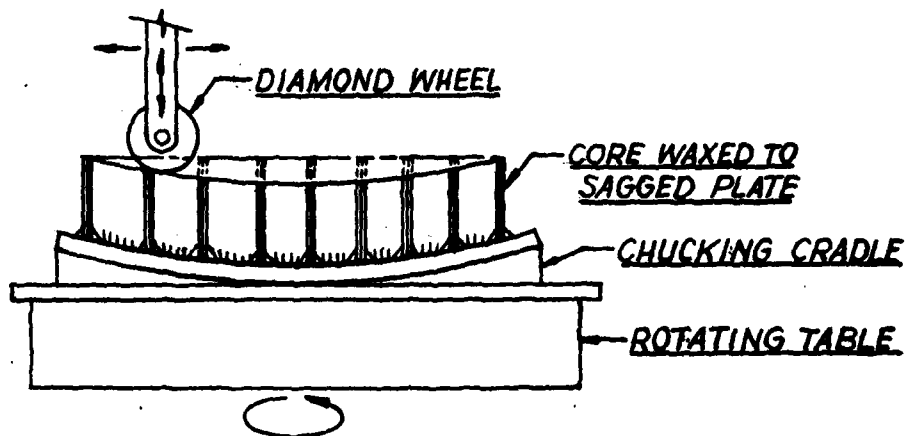
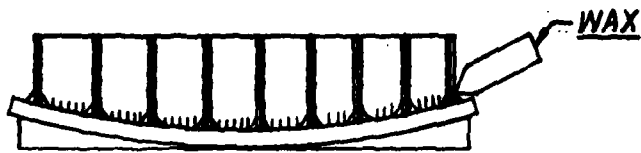
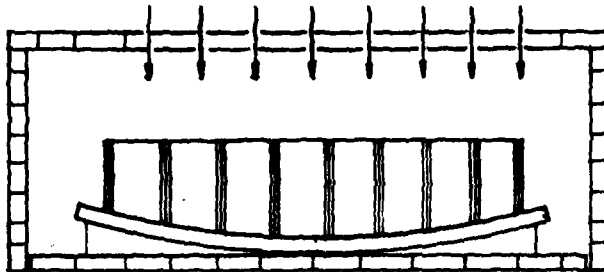

7.15 CLEANING

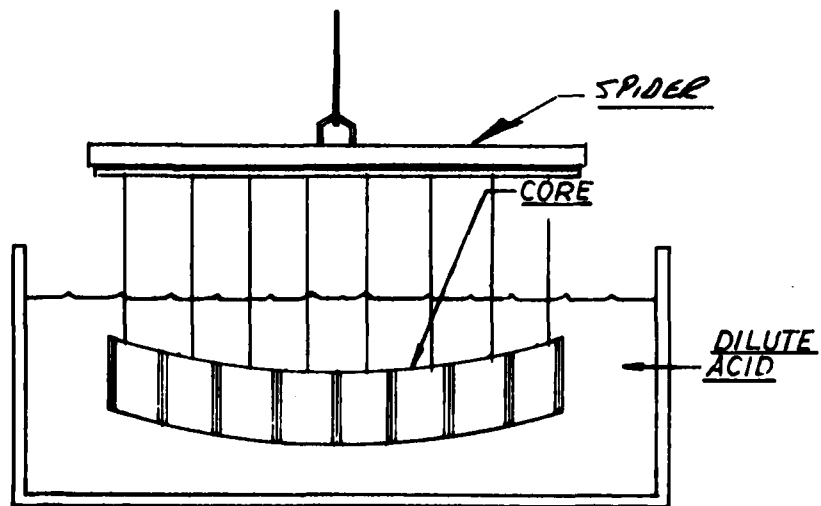
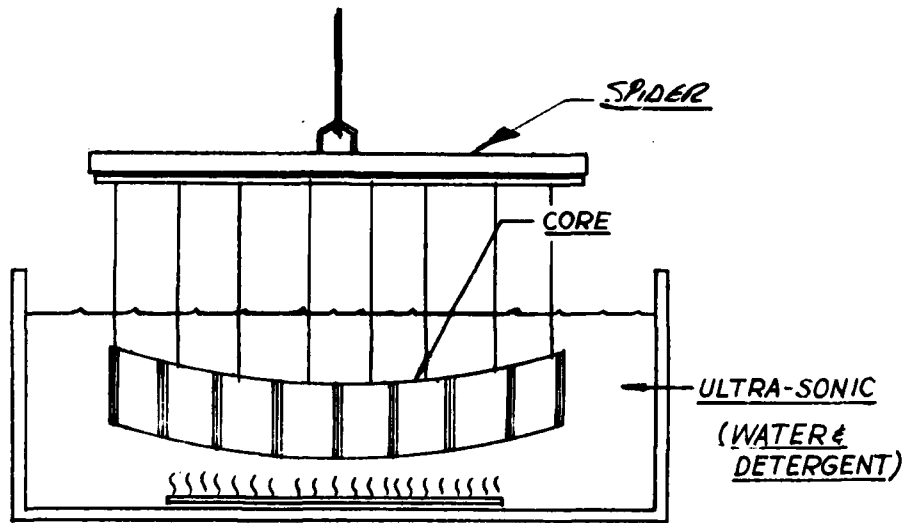
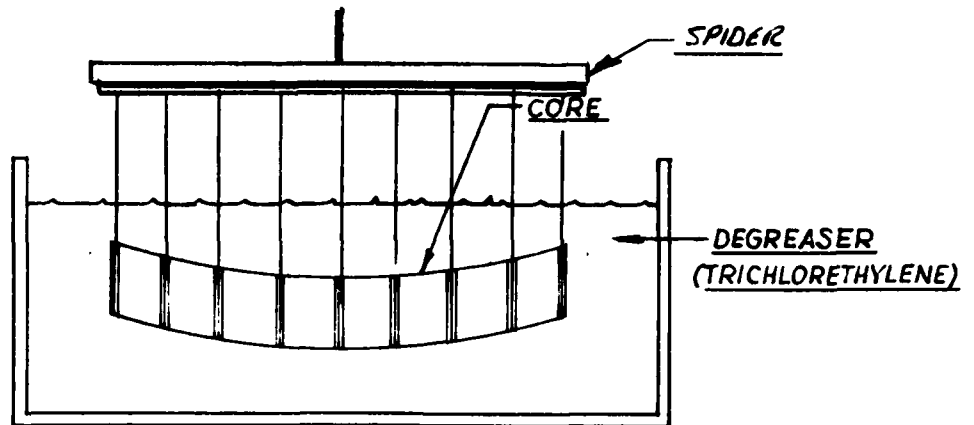

7.16 SEALING

7.16.1 Assembly

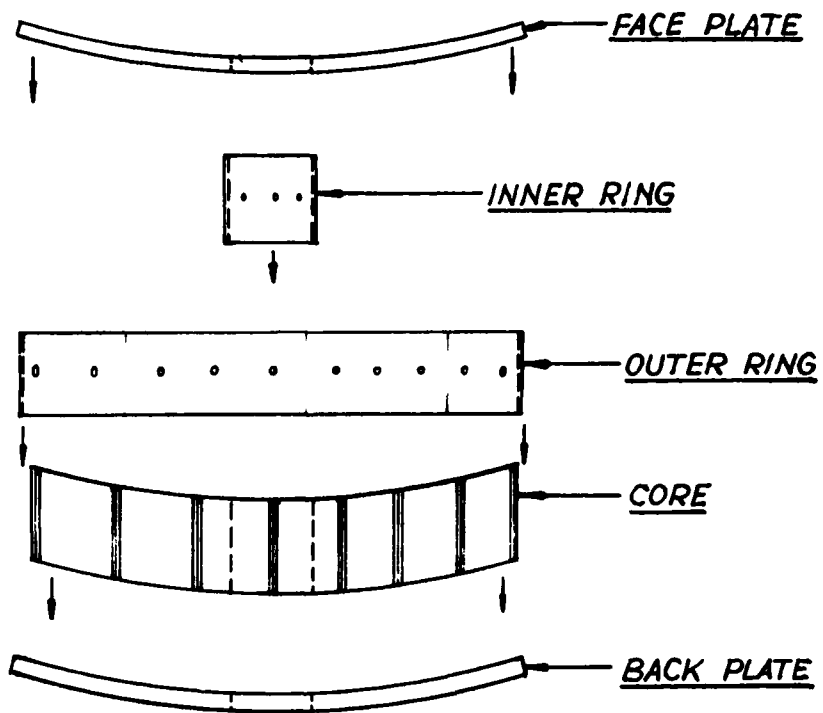

7.16 SEALING

7.16.2 Firing

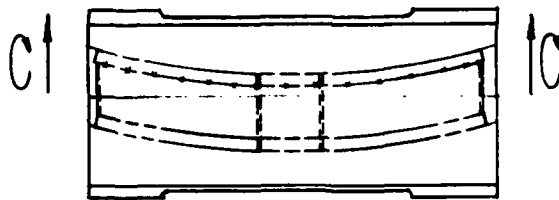
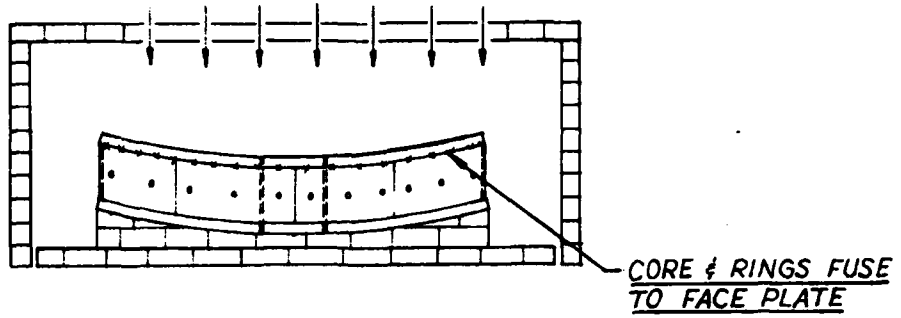

ASSEMBLY BOXED & FLOPPED

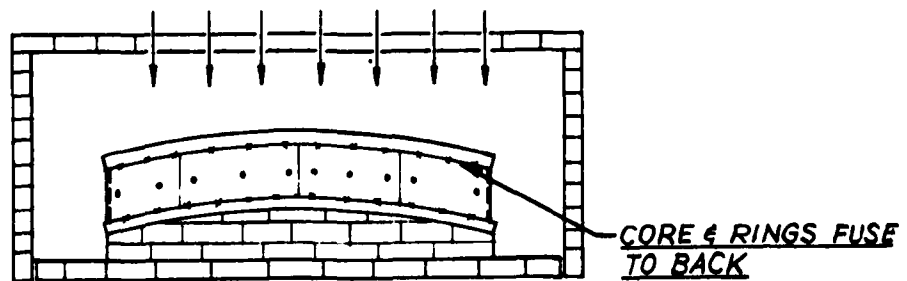

8.0 TABLES

8.1 PROCESS LIST

- 2.1 Batch Preparation
- 2.2 Glass Laydown
- 2.3 Plate Flowout
- 2.4 Strut Stack Sealing
- 2.5 Plate Sagging
- 2.6 Plate Grinding
- 2.7 E11 Grinding (Posts and Struts)
- 2.8 E11 Making
- 2.9 Core Sealing
- 2.10 Ring Manufacture and Sagging
- 2.11 Ring Sealing
- 2.12 Core Grinding
- 2.13 Cleaning
- 2.14 Sealing
- 2.15 Annealing

8.0 TABLES

8.2 MIRROR BLANK SPEC. (Assumed)

Diameter	4.00 meters (157.48")
Aspect Ratio	7-1
Thickness	0.57 meters (22.50")
Radius of Curvature	12.19 meters (480.00")
Center Hole	0.61 meters (24") to 0.91 meters (36")
Strut Thickness	5.08 mm (.200")
Strut Size	10.16 cm (4.00")
Blank Back & Front Plate Thickness	3.81 cm (1.50")
Mirror Blank Wt. (approx.)	9000 lbs.

8.0 TABLES

8.3 MANPOWER	<u>MANPOWER</u>						
	(Hours)						
	<u>Trades</u>	<u>Mach. Shop</u>	<u>B&G</u>	<u>Mason</u>	<u>Tech.</u>	<u>Draftsman</u>	<u>Eng'g.</u>
Batch	----	----	----	----	----	----	----
**Laydown	1200	----	300	300	400	120	200
Flowout	----	----	----	----	120	----	40
S. Seal	----	----	----	----	----	----	----
Plate Sag	----	80	----	180	----	24	----
Plate Grind	240	----	680	200	----	40	20
Ell Making	80	940	----	----	----	240	----
Core Seal	800	880	60	40	50	482	340
Ring Seal	284	136	----	----	----	----	----
Cleaning	1027	----	68	----	----	----	----
Sealing	790	80	----	800	----	600	240
Anneal	820	----	100	320	----	----	120
Project Eng.					500		1000
Total	*5241	*2116	*1208	*1840	1070	1506	1960

*Included in equipment costs.

**Includes building 2400 lb. boule furnace in Room #4

Engineering Cost \$198,980

8.0 TABLES

8.4 MANUFACTURING COST (1300# Boule) (8.2 Specifications)

1. Plate flowout	\$497,759
2. Sag and anneal	31,130 @ 95%
3. Front plate	39,753 @ 79.8%
4. Back plate	36,147 @ 79.8%

Front plate = (1) @ 95% + (2) = \$555,087 + (3) = \$594,840
 @ 79.8% = \$745,414.

Back plate = (1) @ 95% + (2) = \$555,087 + (4) = \$591,234
 @ 79.8% = \$740,895.

1 - F. P. @ \$745,414 @ 72.3%	\$1,534,733
1 - B. P. @ \$740,895 @ 72.3%	1,525,429
1 - I. R. @ \$ 24,561 @ 72.3%	50,569
1 - O. R. @ \$103,460 @ 72.3%	213,014
1 - Core @ \$1,065,784 @ 72.3%	2,194,342
1 - LWM seal	<u>181,914</u>
Selling Price	\$5,700,000
Equipment	1,100,000
Development	1,470,000
Engineering	<u>200,000</u>
Total Cost	\$8,470,000

8.0 TABLES

8.5 MANUFACTURING COST (2400 Lb. Boule) (8.2 Specifications)

1. Plate flowout (100" boules)	\$341,157
2. Sag and anneal	31,130 @ 95%
3. Front plate	39,753 @ 79.8%
4. Back plate	36,147 @ 79.8%

Front plate = (1) @ 95% = (2) = \$390,243 + (3) = \$429,996
 @ 79.8% = \$538,842.

Back plate = (1) @ 95% = (2) = \$390,243 + (4) = \$426,390
 @ 79.8% = \$534,323.

1 - F. P. @ \$538,842 @ 72.3%	\$1,121,000
2 - B. P. @ \$534,323 @ 72.3%	1,111,661
1 - I. R. @ \$ 24,561 @ 72.3%	51,096
1 - O. R. @ \$103,460 @ 72.3%	215,237
1 - Core @ \$1,065,784 @ 72.3%	2,217,249
1 - LWM seal	<u>183,813</u>

Selling Price	\$4,900,000
Equipment	1,100,000
Development	1,470,000
Engineering	<u>200,000</u>
Total Cost	\$7,670,000

8.6 Flowout Data

1300 lb. Boule

<u>Stage</u>	<u>Diameter</u>	<u>Area</u>	<u>Thickness</u>	<u>Wt. (#)</u>
Orig.	58.00	2642	37.83	7997
1st Flowout	79.60	4977	20.09	7997
2nd Flowout	96.49	7312	13.57	7937
3rd Flowout	110.82	9646	10.17	7850
4th Flowout	123.51	11,981	8.07	7734
5th Flowout	135.01	14,316	6.63	7590
6th Flowout	145.60	16,651	5.57	7418
7th Flowout	155.47	18,985	4.75	7220
8th Flowout	164.70	21,320	4.10	6992

2400 lb. Boule

<u>Stage</u>	<u>Diameter</u>	<u>Area</u>	<u>Thickness</u>	<u>Wt. (#)</u>
Orig.	100.00	7854	15.28	9600
1st Flowout	119.60	11,236	10.68	9600
2nd Flowout	136.4	14,618	8.10	9465
3rd Flowout	151.40	18,000	6.46	9297
4th Flowout	165.00	21,382	5.31	9080

.150 inches removed from each flowout to remove refractories.

8.0 TABLES

8.7 Glass Required for 4 Meter LWMB (1300 lb. Boules)

8.7.1 Plates

2 @ 33,010 lbs. each 66,020 lbs.

8.7.2 Outer ring

1 @ 4,265 lbs. 4,265 lbs.

8.7.3 Inner ring

1 @ 981 lbs. 981 lbs.

8.7.4 Core

1 @ 47,499 lbs. 47,499 lbs.

8.7.5 Summary

Total glass required for LWMB 118,765 lbs.

At 1300 lbs./boule, this equates to 91 boules.

8.0 TABLES

8.8 Glass Required for 4 Meter LWMB (2400 lb. Boules)

8.8.1 Plates

2 @ 24,419 lbs. each 48,838 lbs.

8.8.2 Outer ring

1 @ 4265 lbs. 4,265 lbs.

8.8.3 Inner ring

1 @ 981 lbs. 981 lbs.

8.8.4 Core

1 @ 47,499 lbs. 47,499 lbs.

8.8.5 Summary

Total glass required for LWMB 101,583 lbs.

This equates to 20 2400 lb. boules

and 41 1300 lb. boules.

8.9 Glass Required for Wax Plates

2 @ 7 boules each 14 boules

9.0 GANTT CHARTS

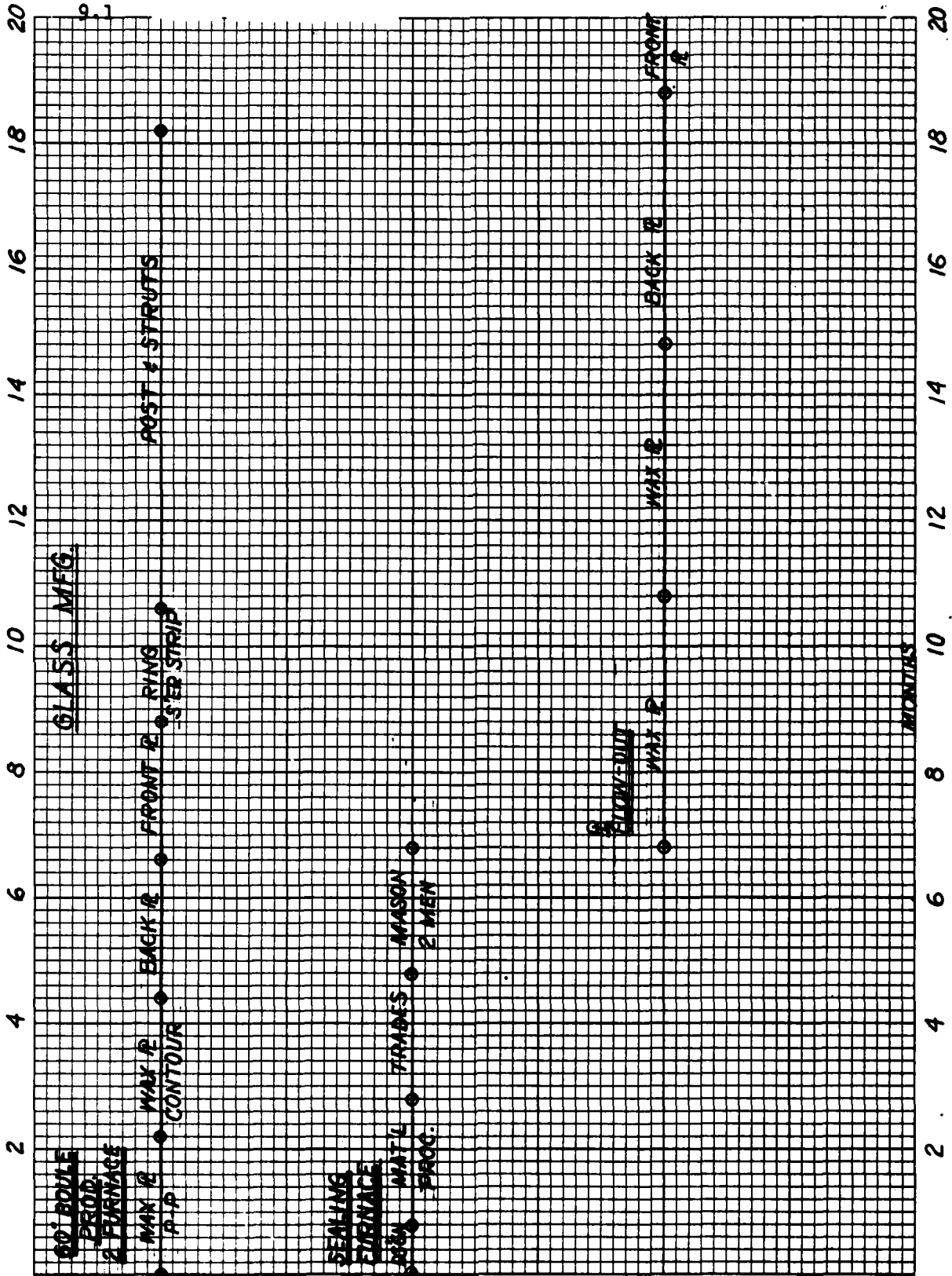

9.1.1

46 0703

K&E 10 X 10 TO THE INCH • 7 X 10 INCHES
NEUPPEL & GIBBS CO. MADE IN U.S.A.

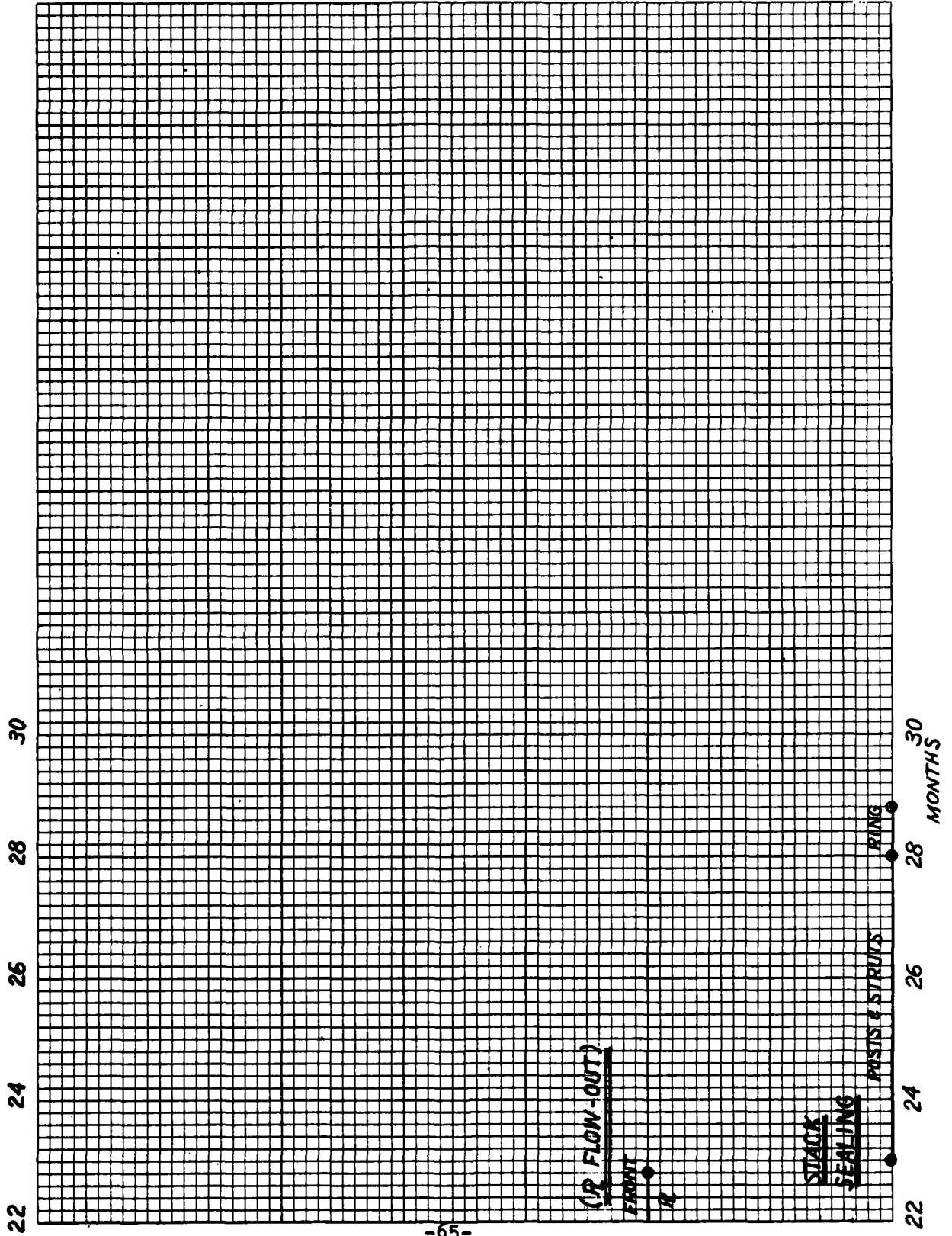

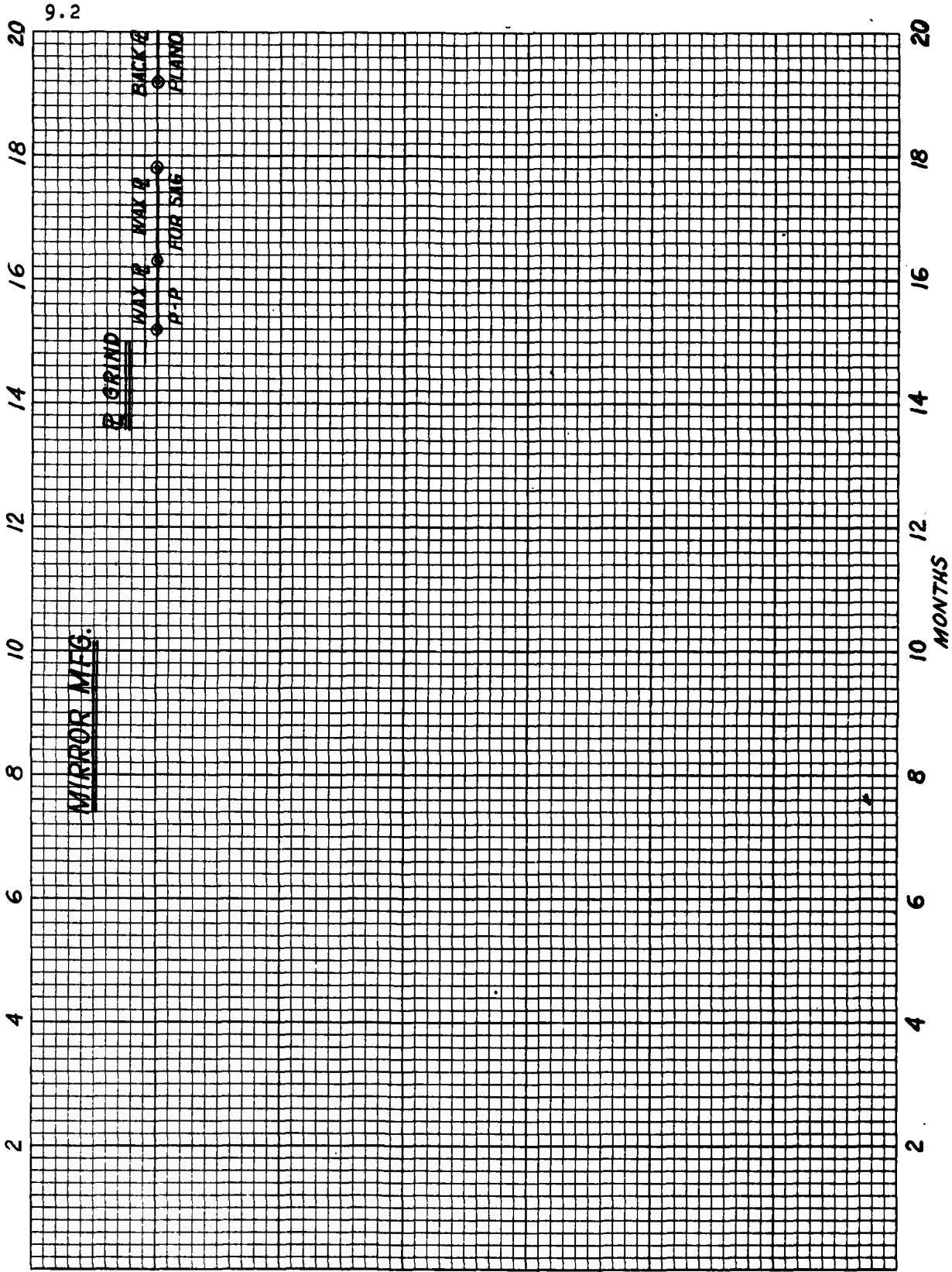

9.2.1

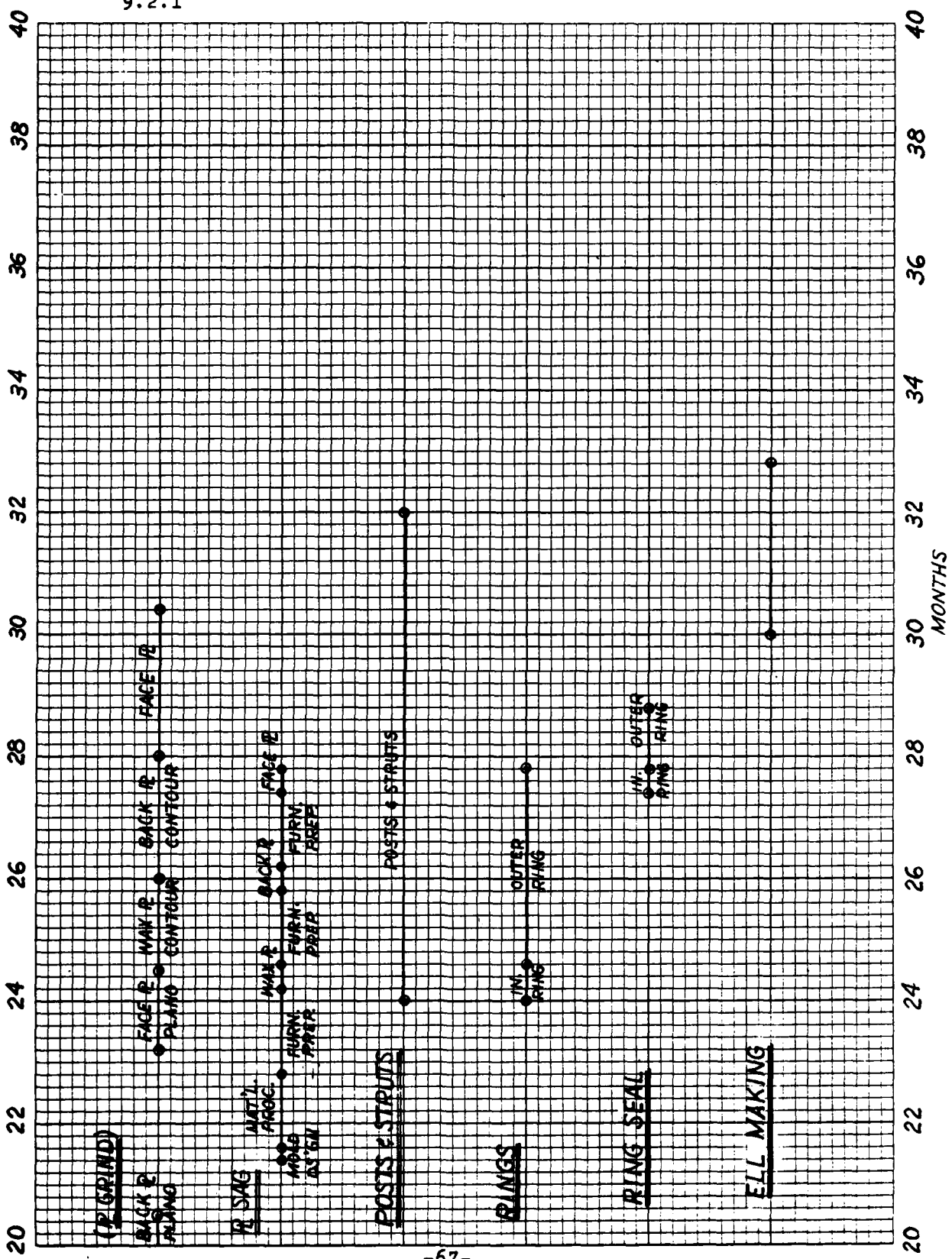

KOE 10 X 10 TO THE INCH .7 X 10 INCHES
KEUFFEL & ESSER CO. MADE IN U.S.A.

46 0703

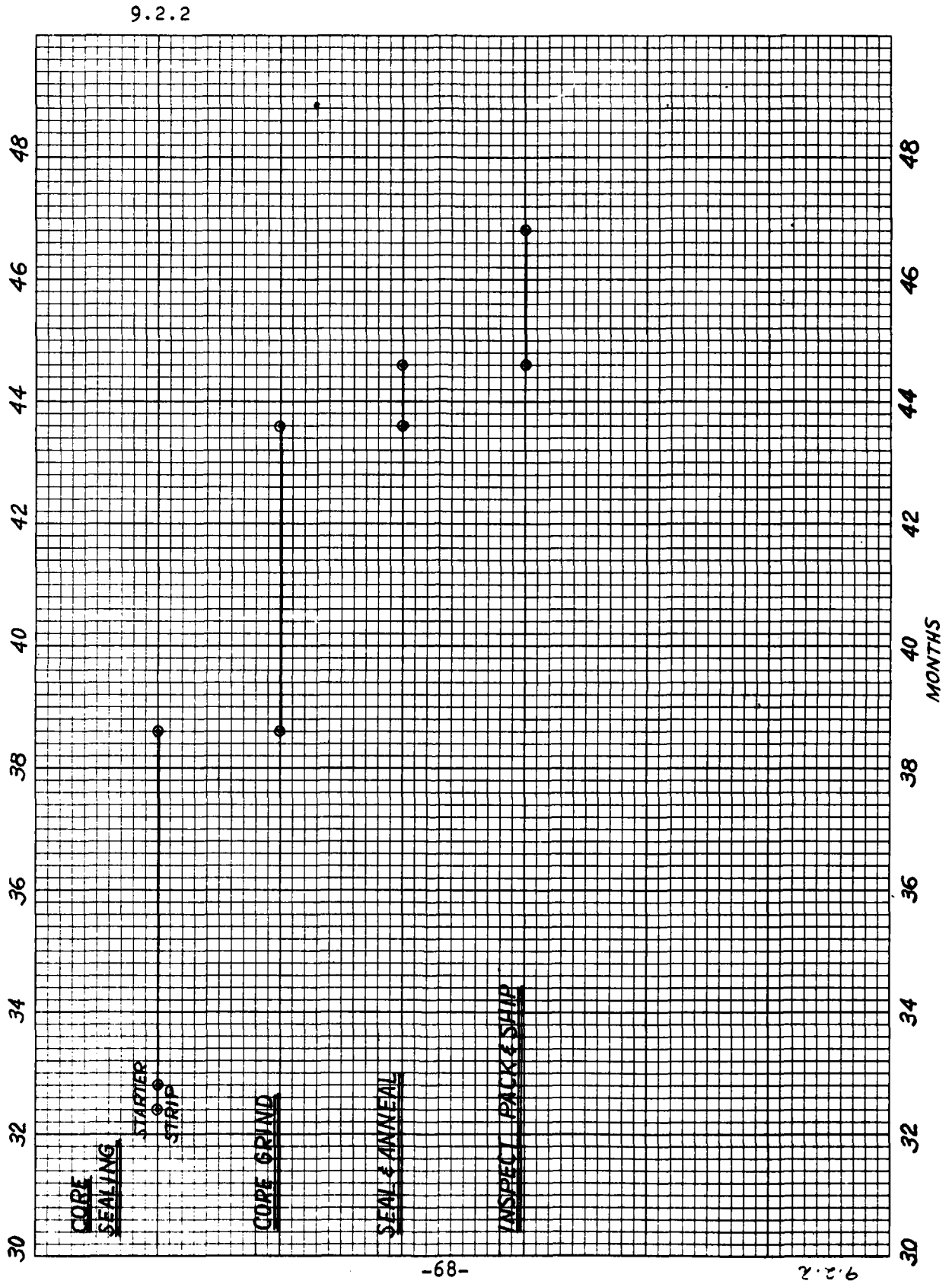

9.4

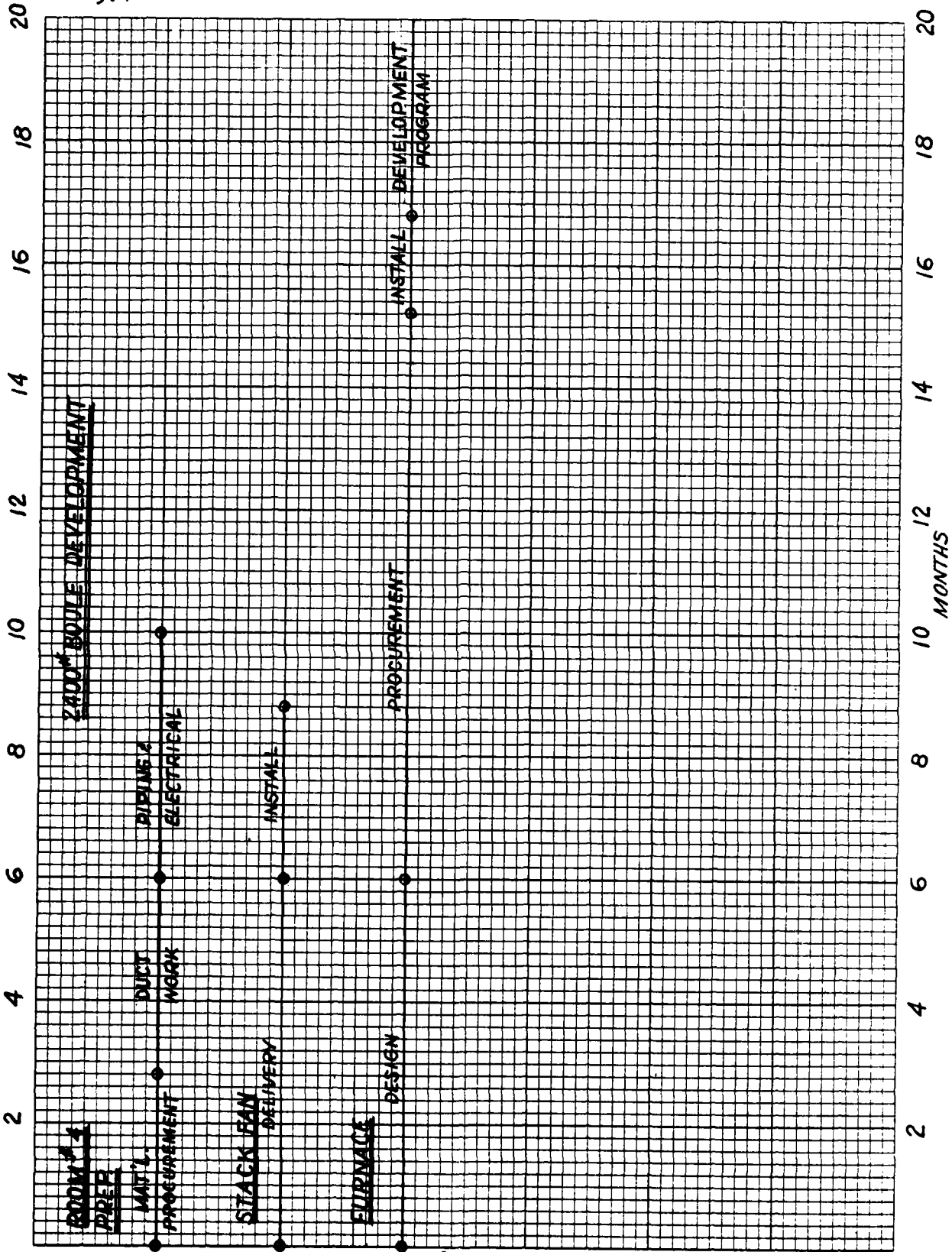

9.4.1

46 0703

KOE 10 X 10 TO THE INCH 7 X 10 INCHES
NEUFFEL & ESSER CO. MADE IN U.S.A.

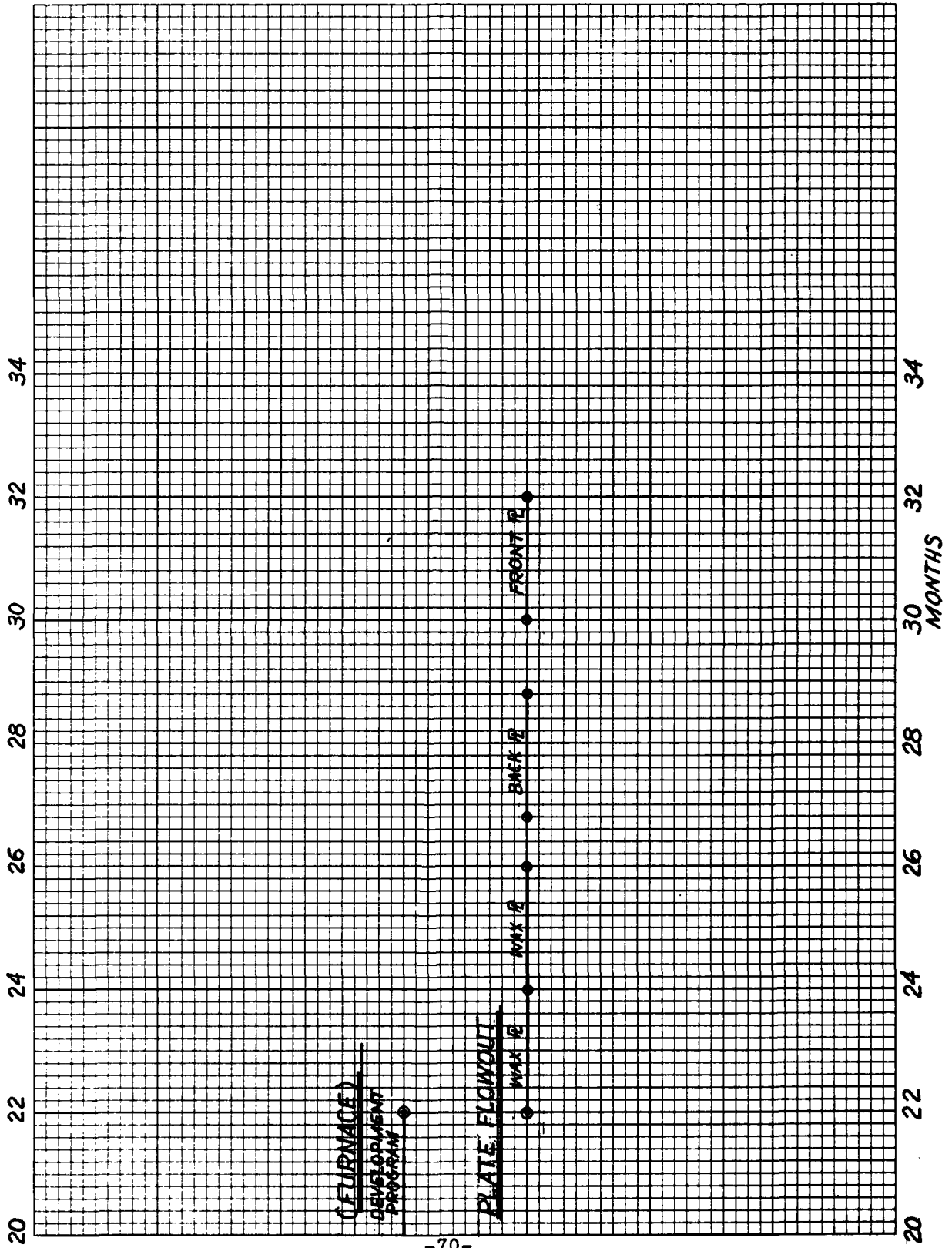

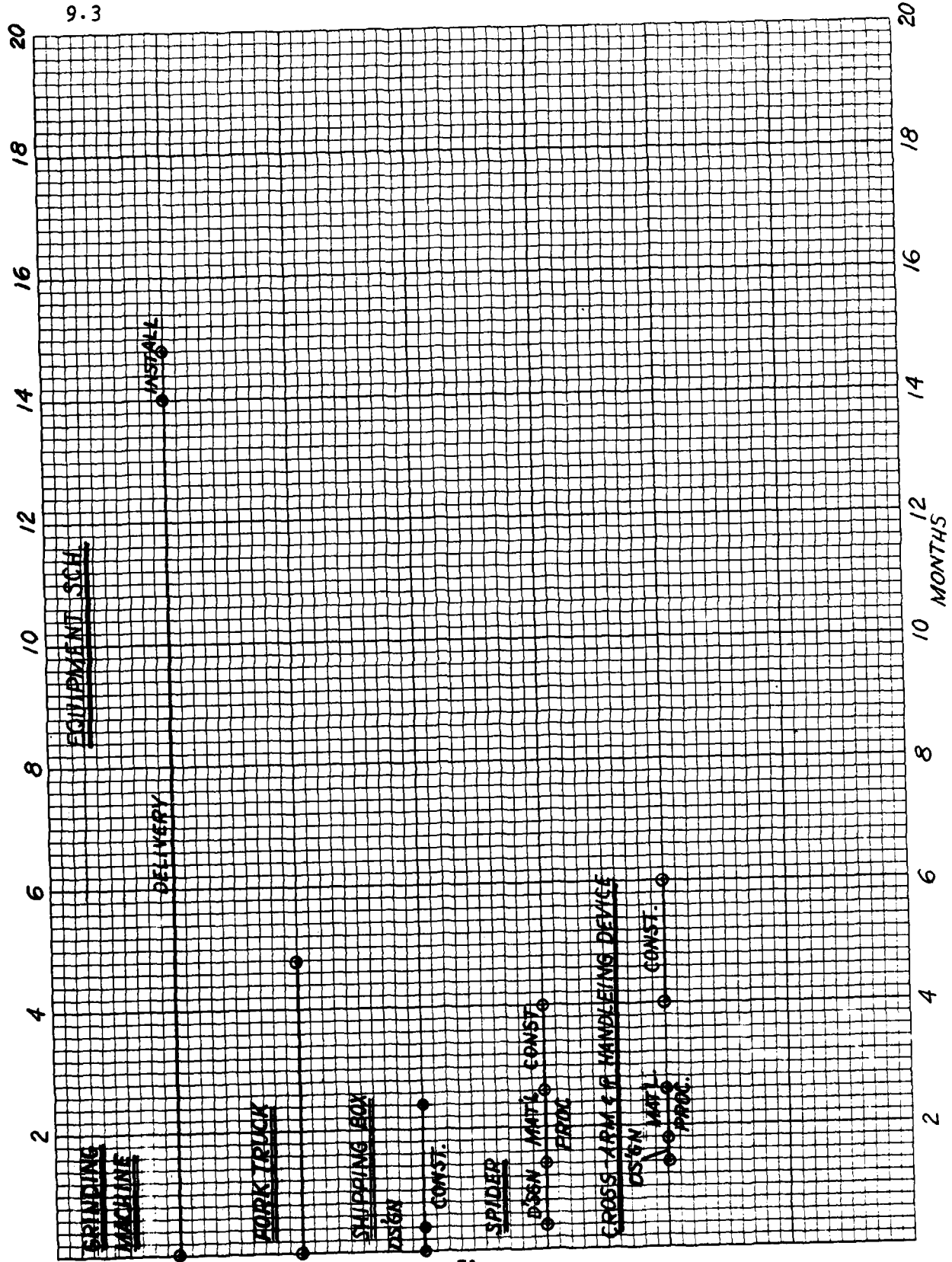

9.3

9.3.1

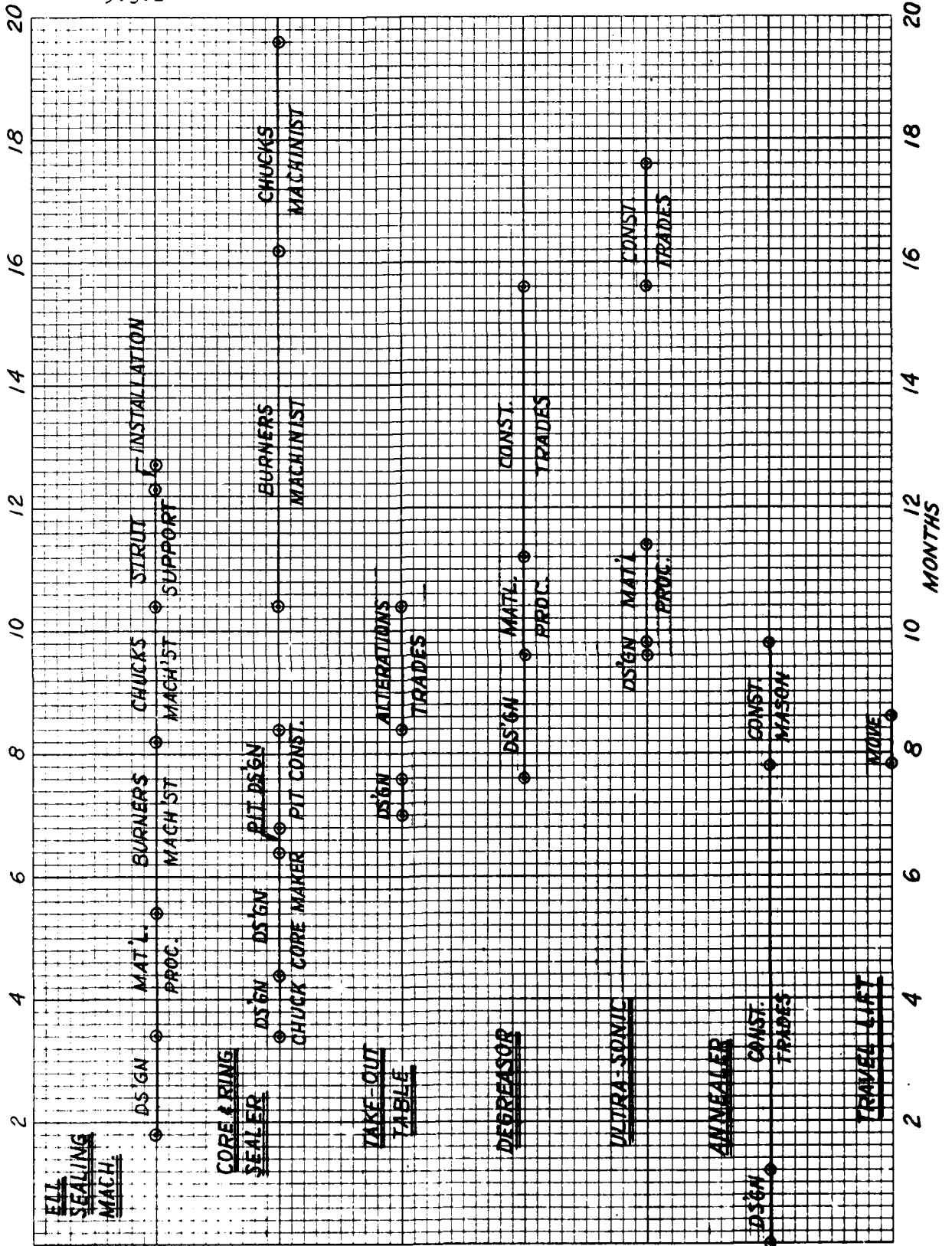

9.3.2

46 0703

KOE 10 X 10 TO THE INCH • 7 X 10 INCHES
KRUPP & BUSH CO. MADE IN U.S.A.

30

28

26

24

22

(CORE RING SEALER)

ASSEMBLY
ALTERATIONS

30
MONTHS

28

26

24

22

20

A decorative border with a repeating floral or scrollwork pattern surrounds the central text.

*MISSION
of
Rome Air Development Center*

RADC plans and executes research, development, test and selected acquisition programs in support of Command, Control Communications and Intelligence (C³I) activities. Technical and engineering support within areas of technical competence is provided to ESD Program Offices (POs) and other ESD elements. The principal technical mission areas are communications, electromagnetic guidance and control, surveillance of ground and aerospace objects, intelligence data collection and handling, information system technology, ionospheric propagation, solid state sciences, microwave physics and electronic reliability, maintainability and compatibility.