

MICROCOPY RESOLUTION TEST CHART  
NATIONAL BUREAU OF STANDARDS-1963-A

AFWL-TR-79-59

**② LEVEL III**

AF-E 200 477

AFWL-TR-79-59

ADA 086087

**AIRBLAST PRESSURE TRANSDUCER FOR MEASUREMENTS IN NUCLEAR BLAST SIMULATORS**

J. V. Quintana

April 1980

Final Report



Approved for public release; distribution unlimited.

DDC FILE COPY

**DTIC ELECTE**  
**S D**  
JUL 1 1980  
**B**

**AIR FORCE WEAPONS LABORATORY**  
**Air Force Systems Command**  
**Kirtland Air Force Base, NM 87117**

**80 5 14 102**

This final report was prepared by the Air Force Weapons Laboratory, Kirtland Air Force Base, New Mexico, under Job Order 10882108. Mr. Joe V. Quintana (NTED) was the Laboratory Project Officer-in-Charge.

When US Government drawings, specifications, or other data are used for any purpose other than a definitely related Government procurement operation, the Government thereby incurs no responsibility nor any obligation whatsoever, and the fact that the Government may have formulated, furnished, or in any way supplied the said drawings, specifications, or other data, is not to be regarded by implication or otherwise, as in any manner licensing the holder or any other person or corporation, or conveying any rights or permission to manufacture, use, or sell any patented invention that may in any way be related thereto.

This report has been authored by an employee of the United States Government. The United States Government retains a nonexclusive, royalty-free license to publish or reproduce the material contained herein, or allow others to do so, for the United States Government purposes.

This report has been reviewed by the Public Affairs Office and is releasable to the National Technical Information Service (NTIS). At NTIS, it will be available to the general public, including foreign nations.

This technical report has been reviewed and is approved for publication.



JOE V. QUINTANA  
Project Officer

FOR THE DIRECTOR



RUDOLPH V. MATALUCCI  
Lt Colonel, USAF  
Chief, Simulation Branch



STEWART W. JOHNSON  
Lt Colonel, USAF  
Chief, Civil Engrg Research Division

UNCLASSIFIED

SECURITY CLASSIFICATION OF THIS PAGE (When Data Entered)

REPORT DOCUMENTATION PAGE		READ INSTRUCTIONS BEFORE COMPLETING FORM
1. REPORT NUMBER AFWL-TR-79-59	2. GOVT ACCESSION NO. AD-A086 087	3. RECIPIENT'S CATALOG NUMBER
4. TITLE (and Subtitle) AIRBLAST PRESSURE TRANSDUCER FOR MEASUREMENTS IN NUCLEAR BLAST SIMULATORS		5. TYPE OF REPORT & PERIOD COVERED Final Report
		6. PERFORMING ORG. REPORT NUMBER
7. AUTHOR(s) J. V. Quintana		8. CONTRACT OR GRANT NUMBER(s)
9. PERFORMING ORGANIZATION NAME AND ADDRESS Air Force Weapons Laboratory (NTED) Kirtland Air Force Base, NM 87117		10. PROGRAM ELEMENT, PROJECT, TASK AREA & WORK UNIT NUMBERS 10882108/64711F
11. CONTROLLING OFFICE NAME AND ADDRESS Air Force Weapons Laboratory (NTED) Kirtland Air Force Base, NM 87117		12. REPORT DATE April 1980
		13. NUMBER OF PAGES 30
14. MONITORING AGENCY NAME & ADDRESS (if different from Controlling Office)		15. SECURITY CLASS. (of this report) Unclassified
		15a. DECLASSIFICATION/DOWNGRADING SCHEDULE
16. DISTRIBUTION STATEMENT (of this Report)  Approved for public release; distribution unlimited.		
17. DISTRIBUTION STATEMENT (of the abstract entered in Block 20, if different from Report)		
18. SUPPLEMENTARY NOTES		
19. KEY WORDS (Continue on reverse side if necessary and identify by block number) Silicon Transducers Blast Pressure Measurement Explosives		
20. ABSTRACT (Continue on reverse side if necessary and identify by block number) An extremely rugged resistance-based blast pressure transducer is developed over a number of years for use in the blast and shock environment of high explosive-driven nuclear blast simulators. A novel silicon disk with integral (diffused) strain sensitive regions is used as the transduction element for measurements of peaks to 69 MPa and requiring microsecond rise time response. Evolution of the transducer geometry, internal configuration, and special thermal barriers enable sensing applications in extremely violent shock environments to 50 kgs		

DD FORM 1 JAN 73 1473

UNCLASSIFIED

SECURITY CLASSIFICATION OF THIS PAGE (When Data Entered)

UNCLASSIFIED

SECURITY CLASSIFICATION OF THIS PAGE(When Data Entered)

20. ABSTRACT (Continued)

with intense flash and burn thermal environments. A variety of transducer mounting hardware configurations enables side-on sensing of incident overpressure and head-on sensing of reflected and stagnation pressures in a variety of simulator field test configurations.

UNCLASSIFIED

SECURITY CLASSIFICATION OF THIS PAGE(When Data Entered)

CONTENT

<u>Section</u>		<u>Page</u>
I	INTRODUCTION	3
II	TECHNICAL DESCRIPTIONS	6
	Measurand	6
	Environment	6
	Other Considerations	8
	Transducer	10
	Transducer Performance	26
III	CONCLUSION	29
	DISTRIBUTION	30

ACCESSION for		
NTIS	White Section	<input checked="" type="checkbox"/>
DDC	Buff Section	<input type="checkbox"/>
UNANNOUNCED		<input type="checkbox"/>
JUSTIFICATION _____		
BY _____		
DISTRIBUTION/AVAILABILITY CODES		
Dist.	AvAIL	and/or SPECMA
A		

ILLUSTRATIONS

<u>Figure</u>		<u>Page</u>
1	High explosive simulation technique	4
2	IS disk pressure - sensing assembly	11
3	HGL-375-10K pressure transducer	14
4	HKS-5-375-10K blast pressure transducer	16
5	AFWL-BP hardware system	19
6	HKS-11-375-10K blast pressure transducer	21
7	Carport scheme HEST cavity BP	23
8	Debris shield scheme for head-on sensing	25

## I. INTRODUCTION

Since 1955 when intercontinental ballistic missile (ICBM) programs were initiated, the Air Force has had overall responsibility for operational activities. Included is the responsibility for implementing and maintaining a retaliatory ICBM launch capability usable in event of nuclear attack. To accomplish this most important mission requires knowledge of the survivability and/or vulnerability (S/V) of our present and future ICBM launch facilities in view of anticipated nuclear weapons threats. Ideally, such knowledge would be acquired by testing with actual nuclear devices. However, because of nuclear test ban treaties, such testing could not be accomplished. Thus, an alternative is critically needed to provide the necessary information.

At the Air Force Weapons Laboratory (AFWL) Civil Engineering Research Division, intense analytical and experimental efforts established that conventional high explosives could be detonated to produce a blast overpressure wave whose characteristics would scale to those of blast waves generated by specific nuclear detonations. Thus, a technique was identified which would produce a predictable stimulus to apply to launch facility structure specimens for the purpose of S/V testing. The technique was designated as the High Explosive Simulation Technique (HEST) and was established as the viable non nuclear alternative to nuclear testing of ICBM launch facilities.

Early in the development of HEST, a functional configuration was established for producing the blast overpressure environment. Figure 1 shows the configuration. Note that the main features of the HEST are (1) the HEST cavity, (2) the explosives, and (3) the soil overburden. It is apparent that varying the size of the cavity, mass of explosives, or mass of the soil overburden will effect a tailoring of the blast overpressure wave. Structures specimens located in the test bed under the explosives experience the blast-induced shock environment and yield their characteristic responses. Measurements of blast pressure in the cavity and of stress and motion responses in the specimens provide the information which becomes the basis for S/V assessments of strategic ICBM launch facilities.

Since 1965 a progression of major field test programs has been conducted by the AFWL. Significant advancements in simulator development have resulted in a high degree of airblast and ground shock simulation capability. Generating and applying the predictable test environment has enabled evaluation and selection

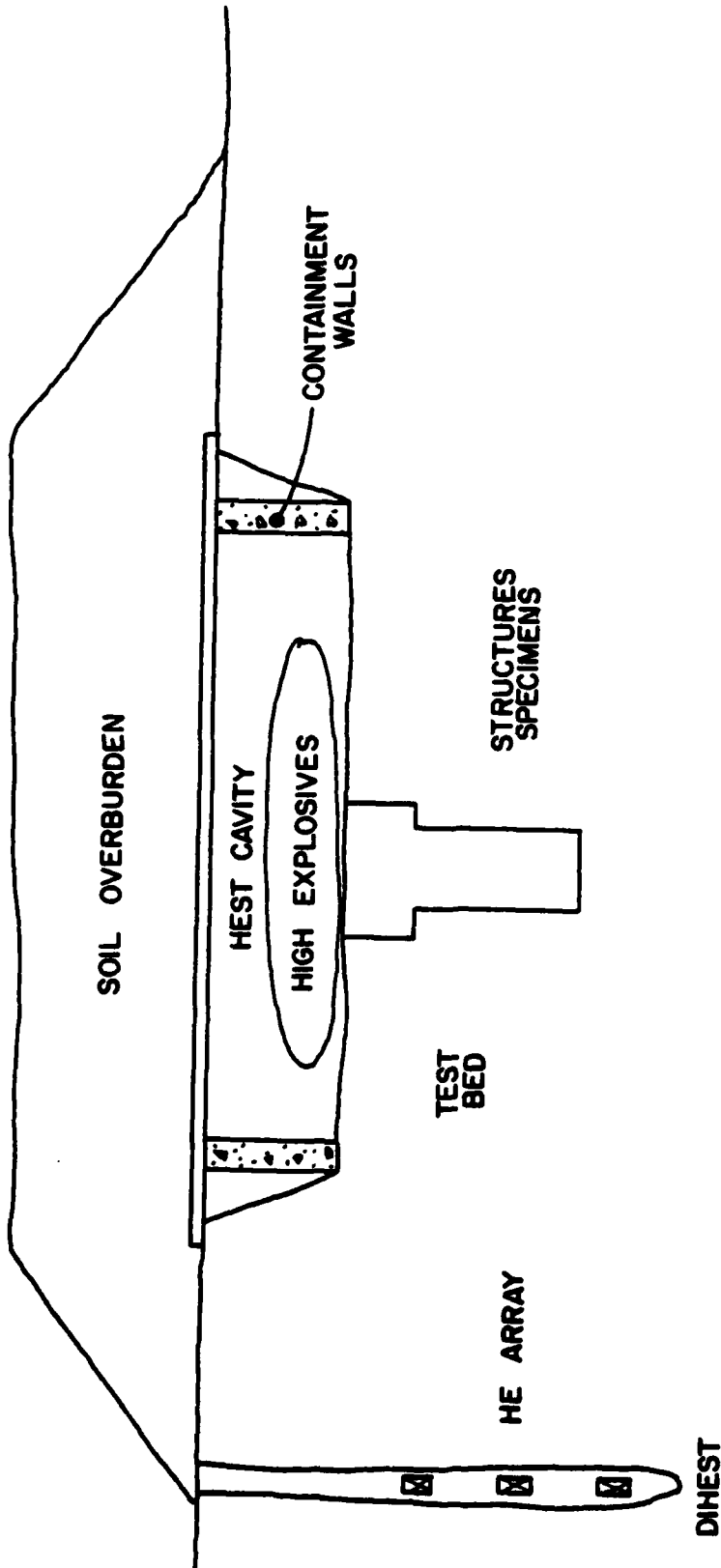

Figure 1. High explosive simulation technique (general configuration).

of the most cost-effective, survivable structures possible for weapons systems considerations. Most recent efforts have been toward generating and applying special blast overpressure and blast flow environments to structure specimens of MX mobile missile siting systems. Significant progress has already been realized in developing new techniques and in modifying older HEST methods toward simulating new threat scenarios. Such progress in the overall efforts of nuclear blast simulator development and S/V testing has been enabled by the quality of blast pressure data acquired in field tests. It is only with measurement data of the blast pressure generated in the simulator that simulator performance may be determined as the basis for structural response measurements and analyses essential to S/V determinations.

This report describes the specialized transducer developed to acquire the blast pressure data in simulated nuclear blast testing. Considerations of measurand and environment are indicated to establish a basic survivability and performance wish list for the unit. Rationale in selecting the integrated sensor approach for the pressure transducer is followed by descriptions of applications and performance in major S/V field test programs. Techniques in mounting hardware and developments to eliminate observed inadequacies are described to provide insight to successful blast pressure measurement implementations. A guideline of performance observations indicates results of the efforts toward the means for performing blast pressure measurements in nuclear blast simulators.

## II. TECHNICAL DESCRIPTIONS

## MEASURAND

As indicated, the basic measurement requirement was for data on the average blast overpressure generated in the HEST cavity. The theoretical definition of the parameter was developed from a variety of inputs including parametric data of airblast overpressure profiles of atmospheric nuclear tests made prior to the test ban treaties. Applications of appropriate scaling parameters to the resultant profiles provided inputs to various codes developed to define the physical configuration of the HEST for generating a desired (scaled) blast overpressure profile. The profile, idealized to facilitate use in the simulation and prediction codes, was described as a step-rise to a peak level followed immediately by an exponential decay. Characteristics of the idealized profile were such that the peak level was predicted to be on the order of 21 MPa with the total duration of interest to be on the order of 50 to 100 ms for a specific simulation.

Aside from the theoretical/analytical description of the measurand profile, some factors resulting from the physics of the situation prompted a somewhat modified description of the measurand. Considering the configuration of the cord explosives, placement in the cavity, and the initiation mode for detonating the HE, a high velocity propagating blast wave would be generated. Further, considering that the optimum sensing location for the measurement was in the floor of the cavity, the measurand as seen at the sensing location would be characterized by a rapid rise to a peak (determined by a pressure reflection coefficient and other parameters) followed by a decay tailored in duration and profile by reaction of the HEST cavity walls and the soil overburden. Thus, a modified description of the measurand indicated a rapid rise to a peak of possibly 60-70 MPa and the subsequent total decay within the required duration; a somewhat more severe profile. Unfortunately, however, no estimate of the most important parameter, measurand rise-time, could be established.

## ENVIRONMENT

As in all instrumentation applications, a definition of the test environment should be established for consideration in sensor design. Given that the measurand has been suitably described, considerations of the test environment are critical in terms of survivability of the sensor and to account for any possible environmentally induced noise response.

The detonation of large masses of cord explosives in HEST containments creates an extremely complex violent transient environment. A feel for the magnitude of the environment could only be inferred from considerations of the detonation physics and from information extracted from before-and-after observations of earlier HEST events. Documentary film coverage and posttest inspections of recovered sensor hardware items provided limited information. At the time of the effort reported in this report, four HEST events had been performed at cavity pressure levels to 7 MPa. Information from these events enabled some insight into the transient environment to be considered for instrumentation survivability purposes.

A consensus was that on initiating the cord explosive, a high intensity heat flash precedes the detonation as it travels at approximately 6700 m/s along the cord. As interactions occur with the multiplicity of cords, there is an attendant step-rise of heat flux and buildup in HEST cavity pressure (the measurand) as the HE decomposes. The blast pressure loading the floor of the cavity induces shock motions in the test bed which are combined with the shock from the deep detonations of HE in the DIHEST array. Meanwhile, a burn period follows the HE detonation phase in the HEST during which the plastic casing of the explosive cord, wood, and variety of other combustible materials are consumed with oxygen admitted by the blast destruction of the containment cavity. The early liberation of high velocity gases and the subsequent turbulent flow as the propagating blast wave is formed propels pieces of construction materials (wood, steel, and concrete) as well as sand and rocks at high velocity in all directions. The combination of flash and burn thermal, blast overpressure, multiple shock motion, and blastdriven debris environments constitutes the total HEST test environment considered in devising a measurement system for the desired measurand.

Unfortunately, the exact time-phasing for occurrence of the environment components had not been determined; however, it was certain that the measurand period-of-interest was well within the total environment duration. Thus, it was most important to ensure that the sensor would not significantly respond to any of the components of the environment other than the blast overpressure and the subsequent cavity pressure within the period of interest.

Another unfortunate circumstance that prevailed at the start of this reported effort was the lack of reliable information from which to quantify the environment generally described above. Since there was no interest in simulating thermal aspects of a nuclear detonation with the HEST, little attention had been paid to

quantifying thermal parameters. Consequently, only the opinion of the manufacturer of the explosive cord could be considered in establishing a number to indicate severity of the HEST environment as a heat source to be withstood by a transducer. On this basis, then, the peak temperature at the surface of a detonating cord was determined to be in the range 4000 to 6000 K. Little could be determined toward total heat flux.

Quantifying shock motions at the floor of the HEST cavity was only slightly more revealing. Since airblast-induced earth motions were of high interest in the simulation technique, extensive analytical and empirical efforts had been expended toward predicting shock accelerations induced in the test bed media. Unfortunately the codes had been developed for predicting accelerations starting at approximately 0.5 m below the HEST cavity floor. However, these predictions were judged to be approximately 20,000 g at the surface. Little could be determined on the shock profile and duration.

Thus, the combined environment at the sensing location could be somewhat described quantitatively as being comprised of flash temperatures in the range 1400 to 6000 K, rapid-rise reflected pressure to 60 MPa, and shock accelerations to 20,000 g peak with blast-driven debris. This was the transient test environment that tempered considerations in designing/selecting/implementing instrumentation hardware for measuring blast pressure in the HEST cavity.

#### OTHER CONSIDERATIONS

Other environmental considerations produced factors which further dictated features of a transducer to use in the HEST application. Landline cables running underground from the sensors would experience shock stresses induced directly from the blast and also flexure resulting from earth motions. Thus it was imperative that cables having the least noise response to compressive stresses and flexure be used with the transducer. Coaxial cables used with piezoelectric (PE) transducers had been observed to be poor performers in the shock environment. These considerations, in addition to others associated with fieldability and availability of PE systems, established that non-PE units using multiconductor cable in the landline system were desired for the field test application. Considerations of the ambient environment established that the transducer would experience ambient temperatures in a relatively narrow temperature range. Measurements in earlier HEST cavities revealed that ambient temperatures in the cavity were in the range 4° to 15°C regardless of surrounding climatic conditions.

Thus, stringent ambient temperature performance would not be required. Relative humidity of 100 percent and ground water present in the cavity floor from various sources established that the transducer would need to be moisture impervious.

Finally, from the above considerations of the measurand, transient test environment, and ambient environment, a list of specifications was established defining requirements for performance and survivability of the transducer. Additional considerations of signal properties, signal conditioning, and general fieldability in terms of channel setup and checkout favored a resistance Wheatstone bridge circuit configuration. This configuration would enable a low source impedance and was compatible with equipment already on hand for landline measurement system implementation. Also, the configuration afforded dc response and allowed the shunt resistance expedient for channel scaling (calibration).

To resolve the problem of the lack of measurand rise-time information from which to establish the transducer frequency response criteria, the approach was to consider record channel frequency capabilities for the blast pressure measurement channel. Conditioning and record electronics on hand indicated a 20 kHz channel-per-track frequency response. Allowing validity to the rule-of-thumb that the usable (flat) bandwidth is one-fifth of the 3 dB frequency (20 kHz) and applying the converse, a figure of 100 kHz falls out. The 100 kHz, regarded as the minimum desired and considering the way it was determined, offered no particular merit with respect to the measurand. However, in terms of the empirical bandwidth-rise-time product of a second order system, the rise-time was calculated to be 17.5  $\mu$ s. This figure was approximately three times better than any previous capability and was accepted by theoreticians and analysts as adequate in a first-of-its-kind effort to increase capabilities in high explosive simulation techniques. Following is the wish list summarizing requirements for the desired transducer to perform the HEST cavity blast pressure measurements.

- a. Withstand 20,000 g shock acceleration in all axes.
- b. Withstand flash temperatures to 6000 K and longer duration burn temperatures estimated at 1400 K.
- c. Yield minimum response to shock and thermal inputs.
- d. Be moisture impervious.
- e. Display relative immunity to high velocity debris particles.
- f. Be a resistance-based Wheatstone bridge circuit and produce at least 100 mV full scale at an impedance less than 500 ohms.

- g. Respond with less than 17  $\mu$ s rise-time and sense accurately to 70 MPa.
- h. Have natural resonant frequency > 100 kHz.

At the particular time of need (1968), a transducer to satisfy all the requirements was clearly not commercially available nor could experimenters be located that had successfully instrumented for such an environment. Consequently, considerations were mildly entertained to resort to the highly undesirable practice of inserting mechanical filters or isolators to moderate the test environment (and, unfortunately, the measurand) that the transducer experienced. Thus, some commercially available unit could possibly be used. However, an additional and generally overwhelming burden would exist to determine validity of the resultant data profile in view of the perturbation created by the isolator in the transient test environment. The approach selected was to pursue the most direct transducer-to-measurand coupling possible, thus eliminating the sources of perturbing influences.

#### TRANSDUCER

It was extremely timely when Dr. A. D. (Tony) Kurtz, president of Kulite Semiconductor Products, visited Kirtland AFB in November 1968. The visit was to present his integrated sensor (IS) scheme as a new approach to producing resistance-based stress and motion transducers. The scheme consisted of using microcircuit fabrication techniques to diffuse discrete, electrically isolated, strain-sensitive silicon elements in a silicon substrate which was the force or motion sensing component of the transducer. The sensitive elements diffused into the sensing component became physically integrated into the substrate; thus the term integrated sensor. A number of silicon substrate geometries with integral strain sensors had been produced at Kulite and had shown superior performance in all transducer performance parameters. Of particular interest was the disk geometry in pressure transducers. Kulite had utilized the disk geometry to produce a line of subminiature, low-range pressure transducers which reportedly had displayed excellent overall performance characteristics.

Figure 2 indicates the IS scheme configured for pressure sensors. In this configuration the silicon disk served as the diaphragm or force collector of the pressure transducer. However, instead of transmitting the force to a strain-gage-instrumented force column, flexure, or other mechanical component as in conventional diaphragm pressure transducers, the disk itself was the instrumented component by virtue of the integrated sensor features. The silicon disk was

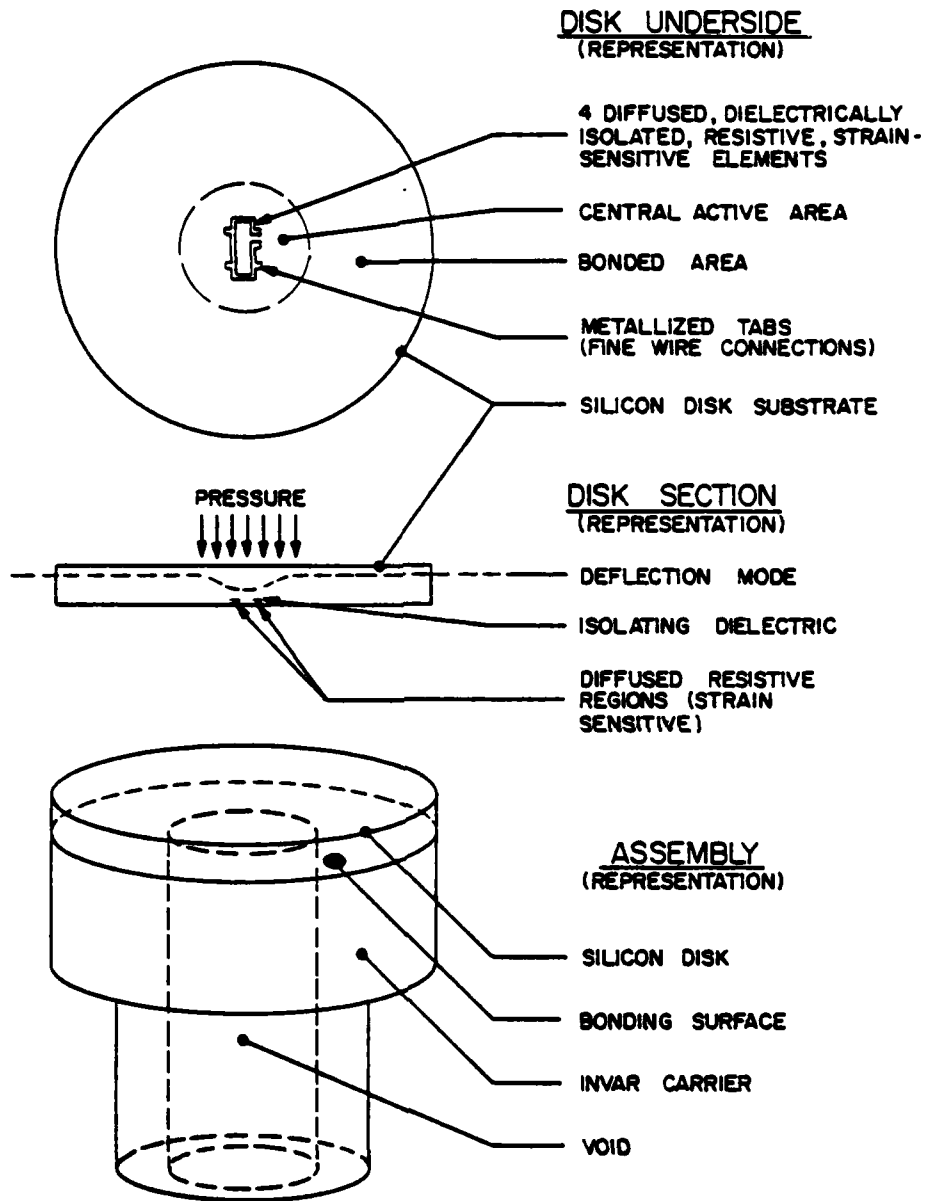

Figure 2. IS disk pressure - sensing assembly.

bonded to an Invar carrier which contained a void in its central area. The resulting configuration allowed the disk to microscopically deflect when pressure was applied to the top surface, thus creating a well-behaved stress field in the central area at the undersurface of the disk. Deflection mode was that of a classical fixed-edge circular disk with tension and compression regions in the active central area. With knowledge of the deflection dynamics and orientation of crystallographic axes, strain-sensitive elements could be optimally located and diffused to maximize the extremely linear stress-strain response. Considering the very high stiffness and low density of silicon, the deflection mode, and the extremely low moving mass, the inherent potential existed for extremely high natural resonant frequencies and correspondingly high measurand response capability. These characteristics with the geometric symmetry and the fact that no other components were required in the transduction scheme offered the potential for a monolithic construction very well suited to shock hardening. Thus, it was apparent that adopting the IS scheme would most probably offer the best performance in terms of measurand response and shock acceleration hardness. However, in the area of thermal hardness, using the IS could become problematic because of the relatively high thermoelectric responses inherent in crystalline materials such as quartz, silicon, ferroelectrics, etc. Subsequent discussions with Dr. Kurtz and Kulite designers established that a 70 MPa pressure transducer using the silicon disk IS could be produced to perform to wish-list requirements; however, it was verified that a thermal protection scheme was imperative.

Based on the desire for a robust field transducer having adequate mechanical protection for the silicon element and on the need for the unit to withstand the environment while sensing the measurand, a novel configuration was devised. It was decided to insert the IS disk/carrier assembly into a 7/16 HEX, 3/8-24 threaded housing. Retention of the assembly against shock accelerations would be by means of a carrier retainer cylinder threaded into the housing. A small port in the sensing end of the housing would admit the measurand to the central active area of the disk. The fact that the disk would be slightly recessed afforded some protection against all but small debris driven head-on against the sensing face. A novel scheme was devised to provide protection against head-on debris and at the same time perform other necessary functions. In order to eliminate dead volume (and resonances) in the port, provide a thermal barrier for the sensing face, provide moisture protection, and effect measurand coupling the port was filled with a low density, low modulus, silicone-based

compound designated TBS-758. The compound had been developed by General Electric as a 5000°F ablative thermal barrier coating for aerospace reentry applications. After considerable investigation, TBS-758 was selected based on apparent suitability to perform all the above necessary functions especially thermal protection. Considering the measurand duration of interest and the possible effects on free response of the silicon disk, it was decided to limit the thickness of the material to 0.8 mm in the port.

Figure 3 shows the configuration for the first 70 MPa IS transducers to be applied in measurements of HEST blast pressures.

Fabrication and production aspects were established by Kulite, and in April 1969 the units, designated HGL-375-10 K, with TBS-758 thermal barriers were received at the AFWL for testing.

The HGL units were tested for static response and found to display unprecedented performance in sensitivity, linearity, repeatability, and hysteresis compared to conventional resistance-based units. However, head-on tests in a 2-inch high pressure shock tube were not as impressive. All but one of the specimens failed on the first shot at approximately 21 MPa reflected. The successful specimen failed on the second shot. Nevertheless, the one piece of test data indicated rise-time response and profile to be far better than any observed from conventional units tested at far lower levels in the 2-inch tube. Resistance checks of the failed units indicated internal circuit problems. Also, it was noticed that the thermal barriers had been dislodged. All of the units were returned to Kulite for postmortem, specifically for microscopic examination of the silicon disks. It was observed that the disks of all units were totally intact and that the failure mode was either at the fine-wire attachment to the disk or in the compensation resistor area. The fact that none of the disk elements was cracked or distressed was a major factor in the decision to continue development of the IS unit for HEST applications.

Subsequent in-depth discussions with Kulite designers resulted in substantial design modifications. Considering ambient use-temperature range, the degree of self-compensation of resistance elements diffused in a given disk, and bridge excitation and balance capabilities, the decision was made to eliminate all internal compensating resistors. Thus, the need for fine-wire interconnections between the disk and the resistor area was also eliminated. Additionally, and more importantly, the decision enabled a new scheme for connections to the disk.

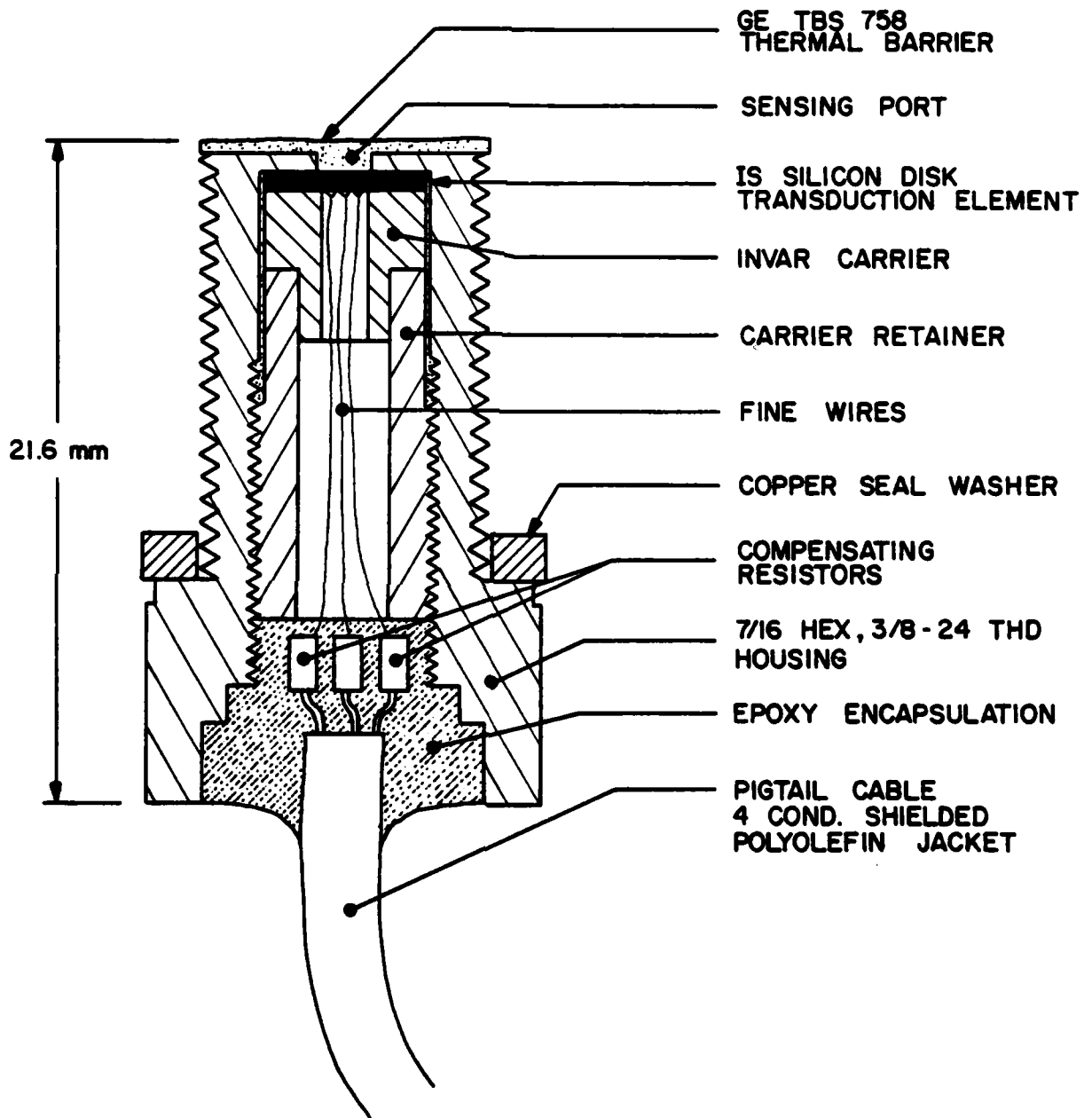

Figure 3. HGL-375-10K pressure transducer.

Metallized bands would be deposited on the underside of the disk to lead from the strain sensor area in the center radially outward to the perimeter. Fine-wire connections would then be made near the edge of the disk in a region of zero deflection/displacement instead of in the central area where maximum motion occurred with pressure application. Modification of the Invar carrier included grooves in the outer surface in which conductors of the pigtail cable would be routed directly to each perimeter connection point. Epoxy encapsulation of the leads in the grooves would greatly enhance shock hardness. On the 3/8-24 housing a recess was machined in the sensing face to effect a lip which would preclude dislodgement of the thermal barrier from pressure acting at the exposed edge of the surface layer. Also, the housing diameter at the sensing end was reduced to slightly less than the minor diameter of the 3/8-24 thread. Thus, a decoupling was effected between the sensing end of the transducer and its mounting hardware to minimize direct transmission of shock stresses. Sandblasting the recess and applying GE-specified primer were incorporated in the fabrication process, and mixing/de-aerating procedures for the TBS-758 barrier material were improved in an effort to further enhance retention of the thermal barrier by better adhesion. The modified configuration was designated as the HKS-5-375-10K, Kirtland unit. Figure 4 shows the HKS-5 unit as received for testing.

Static and dynamic testing of the HKS-5 units was accomplished on an extremely accelerated basis due to the imminence of the HARDROCK SILO field test event designated as HANDEC II. (This was the proof-test for the combined HEST and DIHEST technique of the program, and there was an urgent need to acquire blast pressure data to corroborate/verify prediction and simulation codes.) As for the HGL's, the static performance of the HKS-5-375 IS units was observed to be exceptional. Also, the results of 2-inch high pressure shock tube tests were far more encouraging. Of 15 units tested head-on, only two failed to survive the scheduled three shots each in the range 6.9 MPa to approximately 20 MPa. However, since it had been observed that severe shock accelerations (to an indicated 40 g) occurred in the shock tube end-plate (specimen holder) at approximately 20 MPa reflected, it was judged that the HKS-5 could be a survivable unit for sensing blast pressure in the extremely hostile combined environment. The 13 units were fielded in the HANDEC II event in July 1969 and provided the first full-duration HEST cavity blast pressure data in the combined environment to nominal levels of 20 MPa.

After the HANDEC II field test event, considerable efforts were exerted to recover as much of the instrumentation hardware as possible. The reason was for

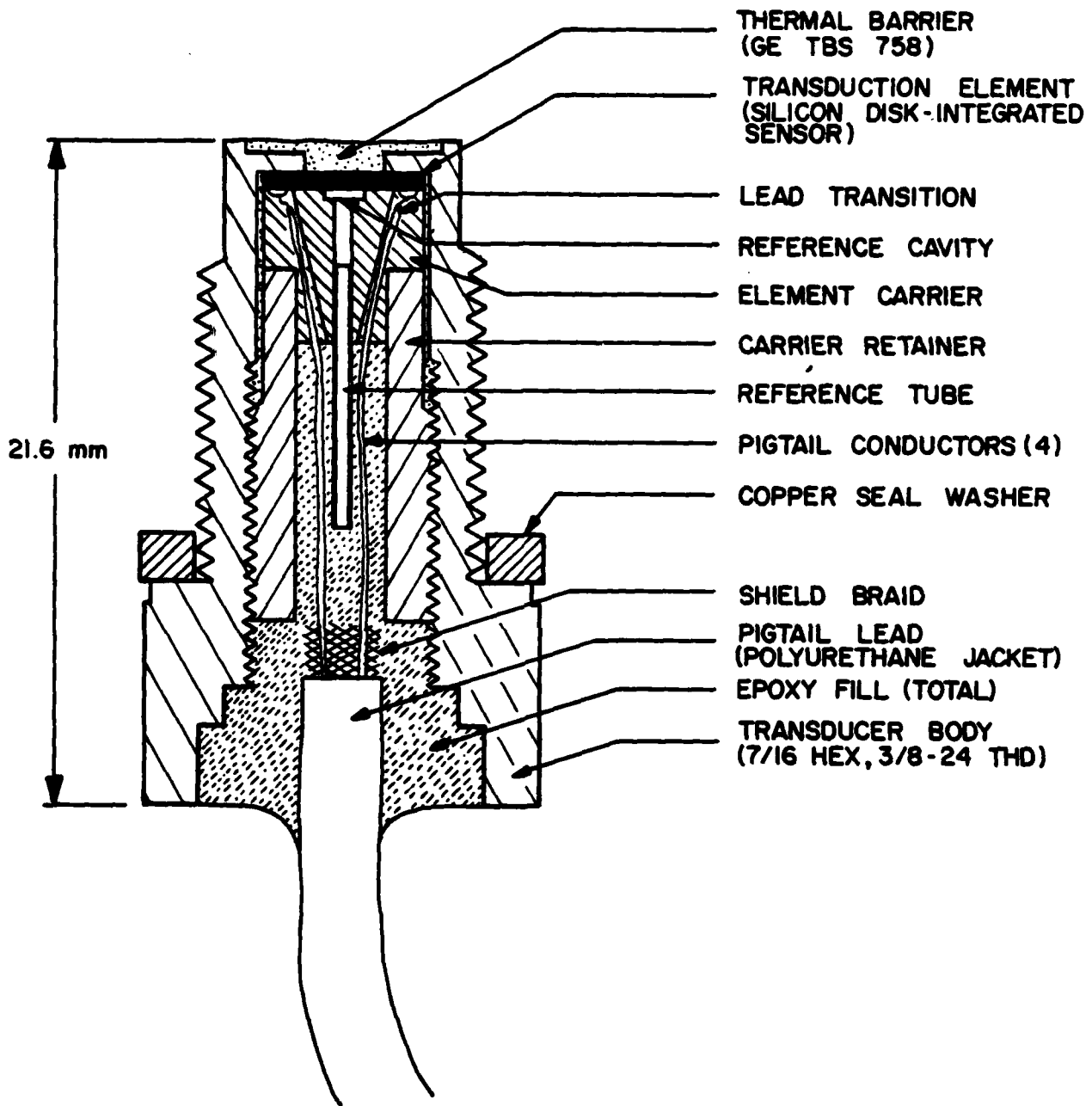

Figure 4. HKS-5-375-10K blast pressure transducer.

simple cost-effective reusability as well as to enable failure mode determinations for channels producing less than full-duration data yield. Special attention was afforded to hardware associated with channels whose data profiles indicated channel failure at blast wave front time-of-arrival (TOA). Comparisons of pretest and posttest resistance values and imbalance output from recovered transducers, together with investigations of cable system continuities in HANDEC II, established that the major cause of channel failure at TOA was the loss of the thermal barrier from the face of the transducer in spite of all precautions. The ensuing speculative explanation was that the blast front deformed the TBS layer exposing an edge so that the forces in the local turbulence completely dislodged the barrier exposing the silicon active area to the test environment. The measurand response, together with the response from massive thermal input directly into the silicon, produced voltage levels that very rapidly drove the channel to band edge saturation. The transducer thermal dissipation rate was such that the effect remained longer than the 100 ms total duration of interest, precluding data yield.

Data yield percentage, although less than desirable, was totally sufficient to enable go-ahead on design of the major HEST/DIHEST field test event, ROCKTEST II. Although only three of the 13 channels displayed the profile characteristic of TOA failure; the simple occurrence prompted investigations into a fix. In the time available, the actions to improve thermal barrier retention consisted of evaluating two approaches; the RTV overcoat, and a method of using an adhesive for bonding the TBS to the unit. Shock tube experiments and static evaluations established that overcoat layers of 0.5- to 1.0-mm-thick RTV 732 silastic would not appreciably alter transducer response in terms of rise-time, delay, and waveform as compared with units having only the thermal barriers installed by the manufacturer. The alternate approach to remove the original barrier intact, apply Eastman 910, and replace the original barrier, although technically sound, was extremely troublesome to perform. Thus, the decision was to use the overcoat scheme in ROCKTEST II, the final event of the HARDROCK SILO program. The total thickness of 1.5 to 2 mm of elastic material over the active area of the silicon was held to be undesirable; however, since there was no way to guarantee adequacy of the factory thermal barrier bond, the overcoat was considered necessary insurance.

Approximately 60 channels of blast pressure measurements were required for the 1548-channel ROCKTEST II event in mid-1970. Improvements in mounting

hardware were implemented for the event as a result of the HANDEC II experience. A plug-in module approach was devised to eliminate fielding problems experienced in HANDEC II. Hardware was designed to eliminate field-splicing of conductors and to provide total monitor capability for setting/checking electrical operating parameters and channel operation at the sensing location. The plug-in feature also enabled total interchangeability, rapid installation of transducers, and ease in recovering sensors posttest without further affecting the electrical or mechanical condition of the channel. Figure 5 shows the AFWL plug-in blast pressure sensing hardware system used in the rock floor of the HEST cavity to sense blast pressure. Data yield percentage realized in the event, while improved over the previous event, was still less than desirable in view of the measurement system designers' noble standard of acquiring "all the data." However, data acquired permitted accurate simulator performance assessment and the subsequent S/V determinations for approximately 10 different strategic structure specimens. Ultimately, highly significant decisions were made to define the most cost-effective functional ICBM launch structures possible in view of the specific threat prevailing at the time.

In mid-1971 the AFWL initiated efforts in the conduct of the MIDDLEGUST program. Among other objectives, this program was to test S/V aspects of surface-sited structures against blast overpressure waves from large spherical masses of high explosives. Thus, a scaled simulation of a near-surface weapon burst was realized.

The nature of the testing, i.e., noncontained explosions over soil, enabled definition of a generally far less severe environment for making blast pressure measurements. Measurements were required as a function of distance from ground zero (GZ) of the HE charge; thus, only the measurements within the "maximum fireball diameter" would require transducers with the environment hardness of the HKS-5 unit. Another factor minimizing severity of the transient environment was that the majority of measurements would be performed in the side-on mode as compared to the head-on mode of HEST cavity measurements. Measurement requirements were to range from predicted pressure levels of 104 MPa close-in to approximately 1.4 MPa and less at far field distances from GZ. Measurements to 0.1 MPa were desired to monitor overpressure in the instrumentation van shelter approximately 800 m from GZ. Thus, the obvious need existed for transducers of other than the nominal 70 MPa range of the HKS-5.

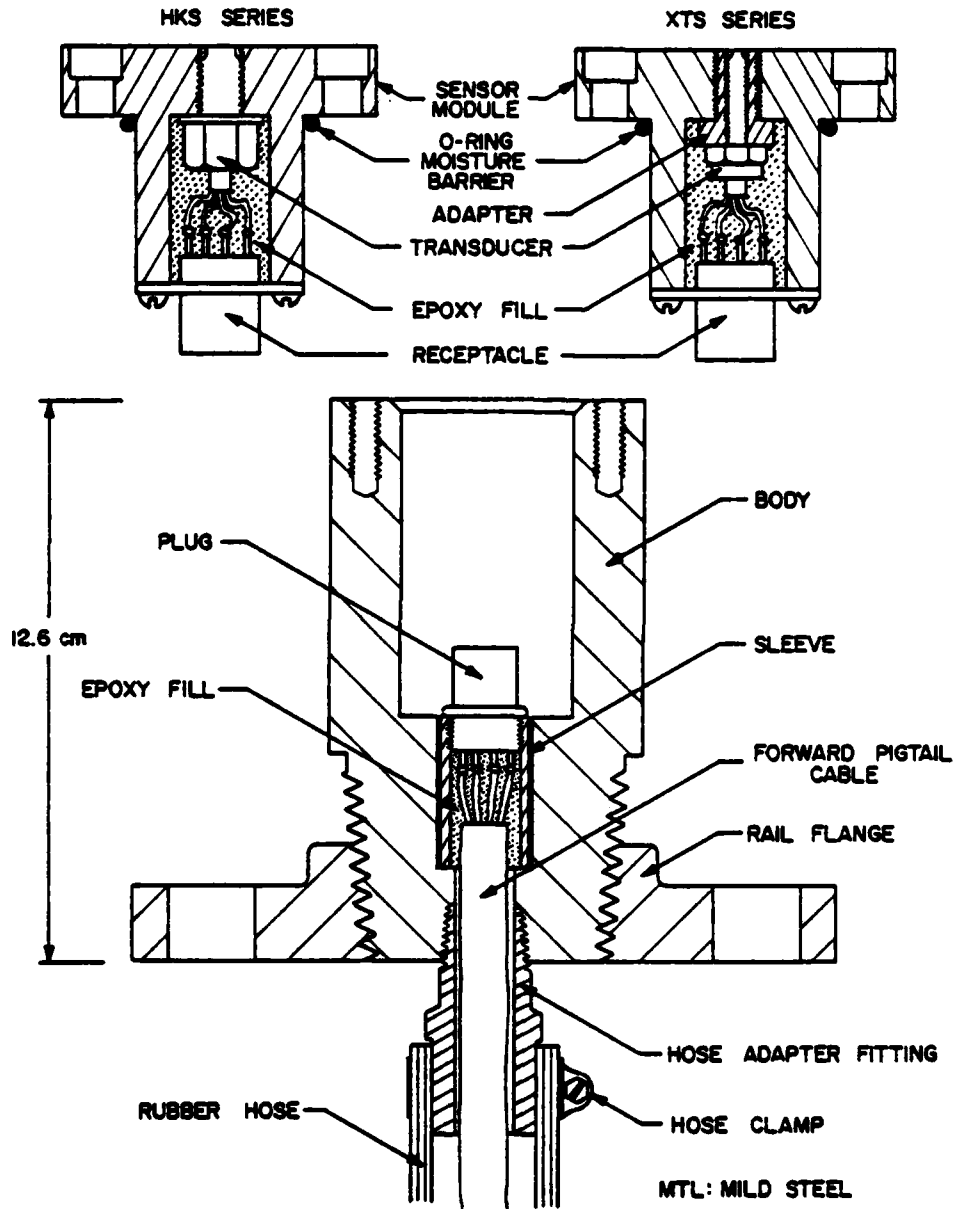

Figure 5. AFWL-BP hardware system.

Discussions with Kulite established that the 70 MPa HKS-5 configuration could be readily produced in other ranges. Based on the MIDDLEGUST requirements and in consideration of design limitations, the HKS-5 configuration was produced in nominal ranges of 3.5, 7, 14, 35, 70, 140, and 207 MPa. Thus, the HKS series of blast pressure transducers was established and successfully used to measure overpressure in the five field test events of the MIDDLEGUST program. Sensitivity considerations dictated that the XT series of Kulite transducers be used for measurements of less than 1.4 MPa. So, an adapter was devised for the hardware system to permit implementation of the less rugged unit (Fig. 5).

A disturbing aspect of the MIDDLEGUST implementations was a recurrence of the thermal-barrier-loss TOA failure mode in the 20K and 30K units sensing close-in to the HE source. Although the number of TOA failures decreased after initial fielding as a result of RTV overcoating, the incidence of the failure mode was unacceptable. Investigations were undertaken by the AFWL into various methods for effecting a reliable thermal barrier that would perform to the thermal protection levels observed thus far for the TBS 758. A wide variety of materials including silicones, refractories, graphite compounds, and others were investigated. From considerations of total performance including low thermal conductivity, the TBS 758 appeared optimal. Consequently, a retention scheme became mandatory. The scheme devised was to use a ported steel cap over the sensing end of the transducer capturing the thermal barrier. The face of the HKS unit was modified to remove the lip originally intended to secure the edge of the thermal barrier. Thus, the bonding area was maximized. Sandblasting the inside surface of the cap, priming it with GE primer, and installing it while the TBS application was fluid implemented the scheme. The cap was then spot-welded to the transducer housing. This configuration of the HKS transducer with the thermal barrier retainer was designated as the HKS-11-375 (Fig. 6).

The HKS-11-375 transducer was fielded in the AFWL-conducted HARDPAN program in early 1973. This program was to evaluate structure-media interactions in experiments using cost-effective modifications of the HEST techniques. For HARDPAN the HEST was sited over a soil test bed with the blast pressure sensing location in the soil floor of the HEST cavity. Average cavity pressure and cavity height were roughly one-third those of the rock HEST events. It was readily apparent that in a shallow cavity the HE would be in proximity (less than 0.3 m) to the transducer sensing face. Since there was no DIHEST aspect of the simulation, the most critical factor for surviving the test environment was the

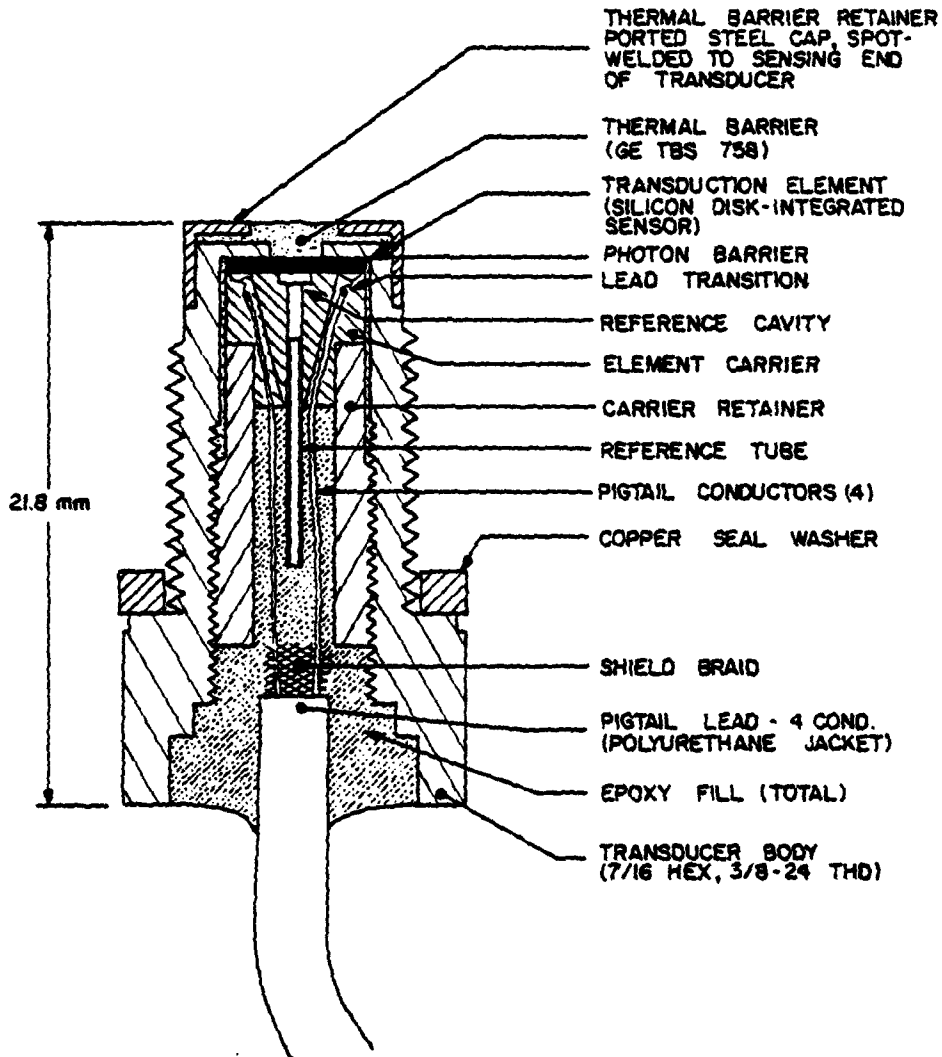

Figure 6. HKS-11-375-10K blast pressure transducer.

proximity to HE. It had been speculated that initial detonation pressure spikes on the order of 275 MPa occurred at the HE surface--thus, it was with some concern that transducers ranged to sense two times the average cavity pressure of 8.25 MPa would necessarily withstand initial pressure spikes of possibly 250 MPa.

A technique was devised to preclude direct impingement of the extremely high-intensity local initial HE detonation pressure spikes. A ported diffuser plate was designed to throttle any detonation spike and was supported above the transducer between the HE and the sensing face in a carport configuration. The plate would effect a delay in registering the early time ( $< 0.05$  ms) direct detonation pressure but allow total registration of the measurand at later time ( $> 0.1$  ms) at the lower pressure levels not fatal to the transducer. Thus, the HKS-11 with the carport scheme was successfully fielded to measure HEST cavity pressure in events of the HARDPAN program. Figure 7 shows the carport configuration.

Posttest assessments of recovered transducers revealed no incidences of loss of the thermal barrier. The thermal barrier retainer scheme had been totally successful in the hostile environment of the shallow HEST in soil.

In 1975 with the onset of the MX concept of ICBM missile siting, the AFWL was required to develop techniques to simulate the blast and shock environments from new threat scenarios. A dynamic airblast simulator (DABS) was required to produce the combined high velocity blast flow environment with the airblast overpressure environment to apply to new-generation structures models. Again, the requirements for full-duration blast pressure measurements in the large explosives-driven shock-tube-like DABS posed difficult problems for blast pressure instrumentation. The major problems were in measuring pitot (stagnation) pressure in the free stream, as required for determining dynamic pressure of the blast flow, and in measuring blast loading (reflected pressures) on structure surfaces. Both types of measurements would necessarily be sensed in the head-on mode. The test environment would consist of high intensity flash and shock front temperatures, high level shock accelerations, blast-driven debris, blast wave front velocities in the range Mach 7 to 9, and incident overpressures in the range of 6.9 MPa with reflected pressures possibly an order of magnitude higher.

The HKS-11 transducer was used for these measurements as well as for the free stream static pressure and facility incident overpressure (side-on) measurements during development of the DABS. To enable head-on sensing in the test environment a debris shield scheme was devised to protect the critical active

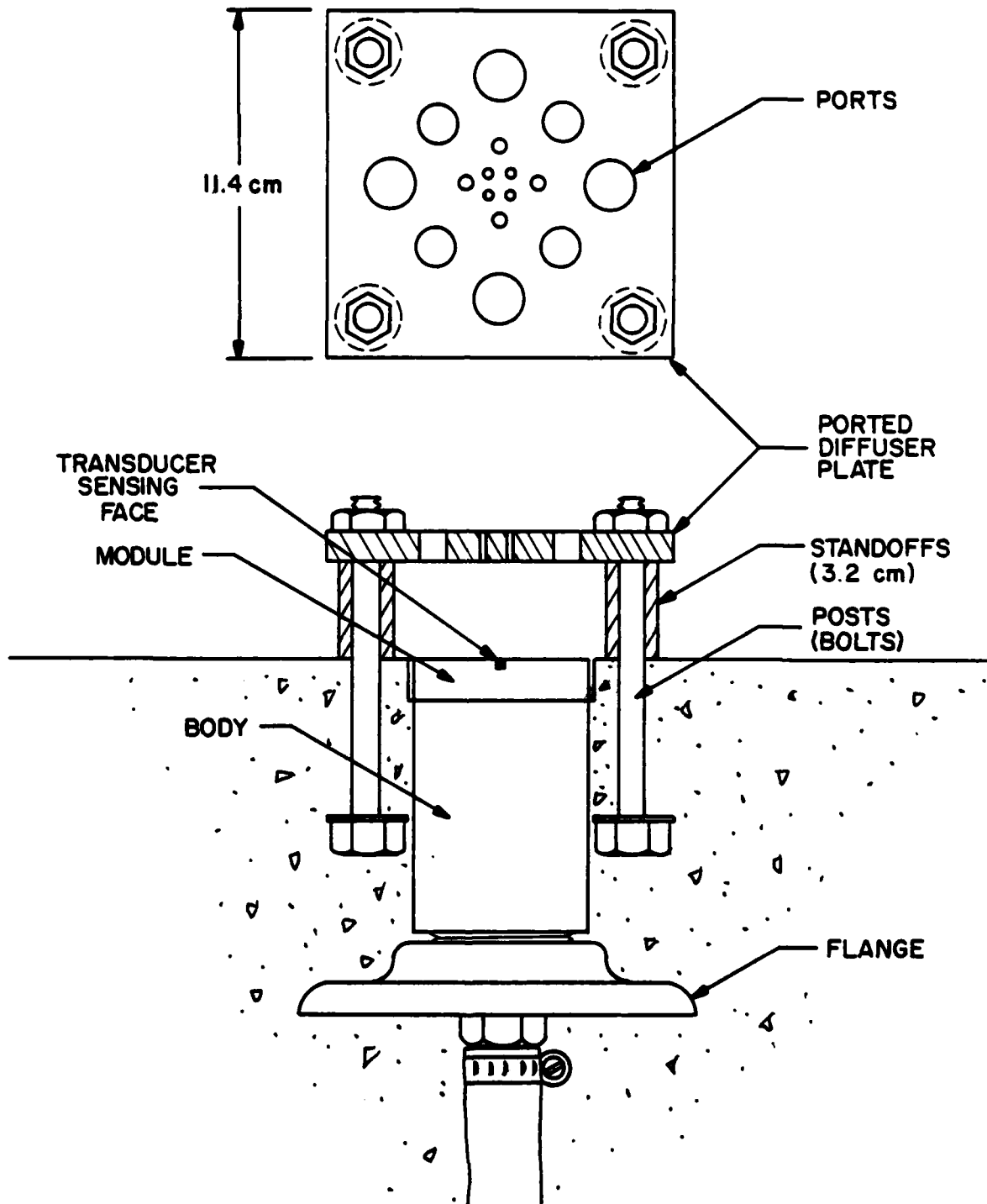

Figure 7. Carport scheme HEST cavity BP.

area in the center of the transducer sensing face. The presence of the thermal barrier retainer on the HKS-11 enabled a debris shield which afforded a highly functional head-on sensing system in the debris-laden blast flow. Figure 8 shows the debris shield configuration. Shock tube evaluations of various aperture configurations established that the church-window design was essentially anti-resonant, produced the least rise-time and profile perturbation, and afforded total protection against potentially fatal debris impact. Thus, design of pitot-static probe tips and surface-flush blast load sensor hardware provided for installation of debris shields over the transducer face.

Near the end of the DABS development phase an anomaly was identified on data plots of side-on-sensed incident overpressure channels. The anomaly was a mild upswing of the baseline beginning approximately 2 ms before shock front TOA and ending with the steep upbeat at TOA. The pre-TOA rise gave the appearance of a toe on the pressure plot--thus the label "toe anomaly." Investigations of a number of possible causes including outrunning shock accelerations, electromagnetic interference (EMI), electrostatic phenomena on landlines, and thermal phenomena indicted the thermal. Laboratory photo-flash experiments patterned after the "screening tests" described in NBS Technical Note 905 (Ref. 1) and a supplementary experimental field test verified a transducer response to thermal radiation. The response profile was similar to the observed toe. With the problem thus identified additional laboratory efforts established that a metal foil disk over the sensing face essentially eliminated the response. Thus, a fix was identified for the photon response problem, but, at some expense of measurand response and with the need to solve the problem of retaining the foil in the test environment. Discussions with Kulite established that a metal film photon barrier could be effected internally during manufacture so that measurand response would not be affected. Although too late for the first events of the MX field test program, the photon barrier was implemented on the HKS-11-375 transducers used in the six subsequent major events testing Shelter and Trench concepts.

Blast pressure data in these events and through the MX HAVE HOST field test program to date have been acquired with the HKS-11-375 units in AFWL BP hardware, with church window debris shields, or with the carport scheme. Data assessment

1. A Test Method for Determining the Effect of Thermal Transients on Pressure-Transducer Response, NBS Technical Note 905, US Dept. of Commerce National Bureau of Standards, US Government Printing Office, Wash DC, March 1976.

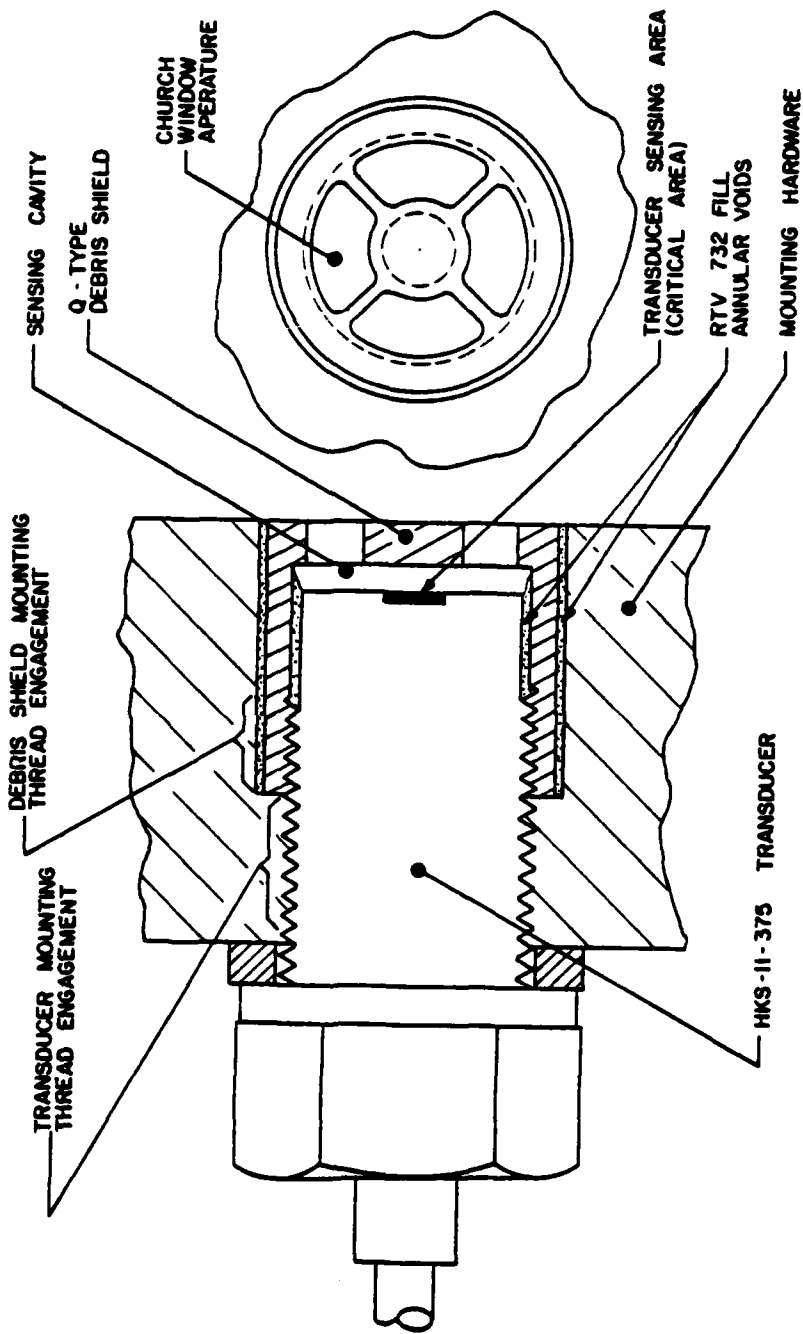

Figure 8. Debris shield scheme for head-on sensing.

has revealed quality data at levels unprecedented in S/V testing. Stagnation pressure data acquired with pitot probes in the free stream indicated routine measurement levels above 70 MPa in spite of transverse shocks measured to be in excess of 40 kg and blast driven debris. Inspection of all side-on sensed incident overpressure data revealed no indication of the toe-anomaly, implying total effectiveness of the photon barrier in the current HKS-11-375 transducers. Also, there have been no incidences of thermal barrier loss since implementation of the retainer. Cost-effective reuse of HKS-11-375 transducers has become routine.

#### TRANSDUCER PERFORMANCE

As indicated in the foregoing and not uncommon in first-of-its kind efforts, the uncomfortable situation prevailed which dictated developing the HKS transducer simultaneously with its implementation in ongoing field test programs. Needless to say, the field test event schedules did not afford the opportunity for comprehensive performance evaluation testing of the various HKS-375 configurations prior to fielding. Consequently, the approach was to evaluate particular aspects of the units which demanded immediate knowledge under prevailing circumstances. Thus, the initial evaluations were a series of essentially quick-look tests of specific parameters. However, over the years considerable test efforts by various agencies have produced quantitative results (within their experimental errors) which have established a baseline for indicating adequacy of the units in various operational aspects. Reference 2 describes some of the efforts.

The following observations are presented in the light of performance evaluations. The observations are not based on a statistically significant sample size and are presented purely as guideline indications of performance observed by the author and pertinent to successful implementations of blast pressure measurements in nuclear blast simulators.

#### Performance Observations (10K range units)

##### 1. Shock Hardness

a. Units routinely subjected to combined pressure and shock environment in a high pressure shock tube end-plate. On-axis shock in the range 20 to 50 kg with reflected pressure in the range 14 to 27 MPa is experienced with no detrimental effects.

2. Air Pressure Transducer Evaluation, AFWL-TR-73-203, Kirtland AFB, New Mexico, August 1974.

b. Attempts to determine failure threshold for pure shock, on-axis and transverse, resulted in survival of 65-85 kg (indicated) drops with no effect on performance (established by comparison of predrop static calibration with postdrop calibration).

c. Acceleration sensitivity at 20 kg peak on-axis was observed to be in the range 0.07 to 0.14  $\mu\text{V/g}$  (on the order of 0.05 kPa/g depending on unit sensitivity and including experimental error). Transverse acceleration sensitivity is less by approximately one-third.

## 2. Thermal Response

a. Convective: Propane torch flame at 3 cm from sensing face. Output response is delayed at least 1 s.

b. Radiative: Unit with photon barrier. A #22 flashbulb head-on at 6 cm from sensing face produces less than 0.2 mV peak output.

## 3. Moisture Imperviousness

a. No change in operating parameters during immersion in tap water at 1 atmosphere for 100 hours. No failures of units installed in test beds inundated by rain or run-off water.

## 4. Measurand Response

a. Change of sensitivity with temperature over the range  $-17.7^{\circ}\text{C}$  to  $51.7^{\circ}\text{C}$  was observed as 2.6 percent. Difference in sensitivity over the ambient use-range of  $10^{\circ}$  to  $24^{\circ}\text{C}$  observed as 0.8 percent.

b. Shock tube response to step input (Sandia shock tube) sensed head-on: Rise-times typically less than 1.5  $\mu\text{s}$ , 60-80 percent initial overshoot with subsequent settling to level sensed. Overshoot excursion plus settling time typically less than 5  $\mu\text{s}$ .

c. Natural resonant frequency has not been observed using impulse stimulation on unmounted unit and 7000 series Tektronix scope. Technique needs refinement. Although shock tube response is not the classical 2nd order undamped profile (due to the thermal barrier and retainer system), the best observations of "ringing frequency" have been in the 605 kHz region.

d. Case Stress Sensitivity. Maximum change in unmounted zero-measurand output compared to mounted at maximum specified torque typically less than 0.2 mV.

e. Static response parameters (linearity, hysteresis, repeatability) typically less than 1.2 percent of full-scale output.

Certainly, observed performance of the IS HKS-11-375-10K greatly surpasses original wish-list specifications for a transducer to perform the blast pressure measurement.

AFWL-TR-79-59

It is hoped that these observations with other considerations related in the text enable a composite indication of sensing techniques and validity of data acquired in the violent transient environment of HE-driven nuclear blast simulators. For additional information on development, evaluation, and applications of the transducer and techniques, the author encourages and solicits inquiries.

## III. CONCLUSION

The integrated sensor approach to resistance-based pressure transducers has enabled an extremely suitable unit for use in explosives-driven field tests. The basic HKS-11-375 has yielded full-duration blast pressure data in extremely hostile transient environments in a wide variety of applications for a number of years. With improvements incorporated as inadequacies appeared in specific experiments, a fully hardened transducer has evolved with totally adequate measurand response and only minor or insignificant noise responses. The unit is virtually indestructible from shock accelerations. Thermal responses to convective and radiant thermal energy are insignificant at the thermal fluxes and intensities of HE-based experiments. Fieldability of the unit has been exceptionally simple and trouble-free in terms of channel setup and operation due to reliability and integrity of the internal circuitry. Mounting hardware designed to withstand the hostile test environments has enabled full performance in providing critical blast pressure measurement data.

Noteworthy, was the cooperation of the manufacturer in resolving problems and responding to technical requirements. Clearly, development of the transducer for such specialized applications would not have resulted otherwise. In keeping with a policy of product improvement, the manufacturer has, in the past year or so, incorporated features toward improving manufacturability of the HKS line of transducers. Also, efforts are underway to extend the upper nominal range. Thus, an improvement of the species is actively being pursued for next-generation integrated sensor transducers.

It is most evident that the performance of the integrated sensor transducer has enabled nuclear blast simulator development and S/V testing of strategic structures to provide information essential to the Air Force ICBM mission.

END

DATE  
FILMED

8-80

DTIC