

AD-A086 528

AERONAUTICAL RESEARCH LABS MELBOURNE (AUSTRALIA) F/6 1/3  
WESSEX HELICOPTER/SONAR DYNAMICS STUDY. ARL PROGRAM DESCRIPTION--ETC(U)  
FEB 79 N V WILLIAMS, C R GUY, M J WILLIAMS  
ARL/AERO NOTE-385

UNCLASSIFIED

NL

AD  
AEROCF

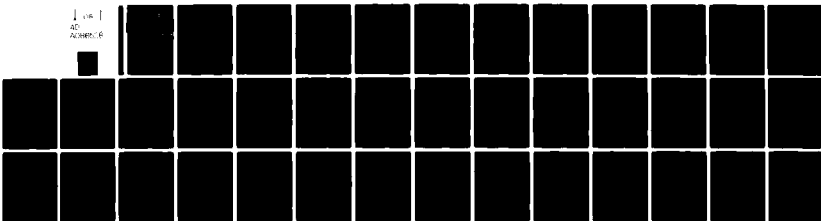

END  
DATE  
FILMED  
8-80  
DTIC

12



**LEVEL**

ADA 086528

**DEPARTMENT OF DEFENCE  
DEFENCE SCIENCE AND TECHNOLOGY ORGANISATION  
AERONAUTICAL RESEARCH LABORATORIES**

MELBOURNE, VICTORIA

AERODYNAMICS NOTE 385

**DTIC  
SELECTE  
JUL 1 1 1980  
A**

**WESSEX HELICOPTER/SONAR DYNAMICS STUDY  
ARL PROGRAM DESCRIPTION AND OPERATION**

by

N. V. WILLIAMS, C. R. GUY, M. J. WILLIAMS and N. E. GILBERT

DEC FILE COPY

Approved for Public Release.



THE UNITED STATES GOVERNMENT  
OFFICE OF TECHNICAL SERVICES  
1215 JEFFERSON AVENUE  
WASHINGTON, D.C. 20540  
ACQUISITION AND BELL THIS REPORT

© COMMONWEALTH OF AUSTRALIA 1979

COPY No 1

FEBRUARY 1979

80 7 10 029

11 Feb 79

12 40

AR-001-603

DEPARTMENT OF DEFENCE  
DEFENCE SCIENCE AND TECHNOLOGY ORGANISATION  
AERONAUTICAL RESEARCH LABORATORIES

14 ARL/AERO NOTE-385

9 AERODYNAMICS NOTE 385

**WESSEX HELICOPTER/SONAR DYNAMICS STUDY.  
ARL PROGRAM DESCRIPTION AND OPERATION.**

Neil M. V. WILLIAMS, Christopher R. GUY, Neil J. WILLIAMS and Neil E. GILBERT

Maxwell

**SUMMARY**

A computer program, representing the dynamic behaviour in flight of the Wessex Mk.31B helicopter and its anti-submarine warfare (ASW) sonar equipment, is described. The program is intended for operation on a PDP-10 computer and is written in CSMP-10 (ARL) simulation language. Instructions for setting up a particular simulated flight manoeuvre are given, together with details of program verification.

POSTAL ADDRESS: Chief Superintendent, Aeronautical Research Laboratories,  
Box 4331, P.O., Melbourne, Victoria, 3001, Australia.

008650 *slw*

**DOCUMENT CONTROL DATA SHEET**

Security classification of this page: Unclassified

- |  |  |
|--|--|
| <p>1. Document Numbers</p> <p>(a) AR Number:<br/>AR-001-603</p> <p>(b) Document Series and Number:<br/>Aerodynamics Note 385 ✓</p> <p>(c) Report Number:<br/>ARL-Aero-Note-385</p> | <p>2. Security classification</p> <p>(a) Complete document:<br/>Unclassified</p> <p>(b) Title in isolation:<br/>Unclassified</p> <p>(c) Summary in isolation:<br/>Unclassified</p> |
|--|--|

3. Title: **WESSEX HELICOPTER/SONAR DYNAMICS STUDY**  
ARL PROGRAM DESCRIPTION AND OPERATION

- |   |   |
|---|---|
| <p>4. Personal Author(s):<br/>Williams, Neil V.<br/>Guy, Christopher R.<br/>Williams, Maxwell J.<br/>Gilbert, Neil E.</p> | <p>5. Document Date:<br/>February, 1979</p> |
| <p>6. Type of Report and Period Covered:<br/>Aerodynamics Note</p>  |   |

- |   |   |
|---|---|
| <p>7. Corporate Author(s):<br/>Aeronautical Research Laboratories ✓</p> | <p>8. Reference Numbers:</p> <p>(a) Task:<br/>DST 74/22</p> <p>(b) Sponsoring Agency:<br/>DST</p> |
| <p>9. Cost Code:<br/>51 7740</p>  |   |

- |   |  |
|---|--|
| <p>10. Imprint:<br/>Aeronautical Research Laboratories,<br/>Melbourne</p> | <p>11. Computer Program(s)<br/>(Title(s) and language(s)):<br/>WESSEX<br/>(CSMP-10 (ARL) and FORTRAN IV)</p> |
|---|--|

12. Release Limitations (of the Document):  
Approved for public release

12-0. Overseas:	N.O.	P.R.	I	A	B	C	D	E
-----------------	------	------	---	---	---	---	---	---

13. Announcement Limitations (of the information on this page):  
No limitations

- |   |  |
|---|--|
| <p>14. Descriptors:</p> <p>Helicopters                      Computerized simulation</p> <p>Dynamic characteristics      Air towed sonar</p> <p>Computer programs              Wessex (Helicopter)</p> | <p>15. Cosati Codes:</p> <p>0103</p> <p>0902</p> |
|---|--|

16. *ABSTRACT*

*A computer program, representing the dynamic behaviour in flight of the Wessex Mk. 31B helicopter and its anti-submarine warfare (ASW) sonar equipment, is described. The program is intended for operation on a PDP-10 computer and is written in CSMP-10 (ARL) simulation language. Instructions for setting up a particular simulated flight manoeuvre are given, together with details of program verification.*

# CONTENTS

	Page No.
<b>1. INTRODUCTION</b>	1
<b>2. PROGRAM DESCRIPTION</b>	2
2.1 The Block-oriented Part (WECRU.MOD)	2
2.2 The Aerodynamics Subroutines (WEAPAK)	2
2.3 The Control Systems Subroutines (WESPAK)	2
2.4 The Cable Subroutines (WECPAK)	3
<b>3. PROGRAM OPERATION</b>	3
3.1 Setting Up a Flight Manoeuvre—Initial Conditions	3
3.2 Setting Up a Flight Manoeuvre—Operating the Model	4
3.2.1 Engaging the Autopilot and Barometric Height Hold	4
3.2.2 Engaging the Hover Coupler	5
3.2.3 Dropping the Cable and Sonar Transducer ("Ball Drop")	5
3.2.4 Alteration of the Pilot's Controls	6
3.2.4.1 Rudder Pedals	6
3.2.4.2 Collective Stick	6
3.2.4.3 Cyclic Stick	6
3.2.5 The Incorporation of Wind Gusts and Water Currents	7
3.2.5.1 Wind Gusts	7
3.2.5.2 Water Currents	7
<b>4. PROGRAM VALIDATION</b>	7
4.1 Differences Between the ARL and WRE Programs	7
4.2 Sample Results and Comments	8
4.3 Cable Model Changes Since Validation	9
4.3.1 Drag Force Components	9
4.3.2 Tension Equation Approximations	9
<b>5. CONCLUDING REMARKS</b>	10
<b>ACKNOWLEDGEMENT</b>	
<b>REFERENCES</b>	
<b>FIGURES</b>	
<b>APPENDIX</b>	
<b>DISTRIBUTION</b>	

Approved For	
By	
Date	
Dist	Special

## 1. INTRODUCTION

The objects of this document are:

- (i) To describe the Acronautical Research Laboratories (ARL) version of the computer program representing the dynamic behaviour in flight of the Wessex Mk.31B helicopter and its anti-submarine warfare (ASW) sonar equipment.
- (ii) To outline the operation of that program.
- (iii) To show the means by which the program was validated.

The Wessex Mk.31B helicopter has a single, fully articulated main rotor (4 blades) and conventional pylon-mounted tail rotor (also 4 blades). Its all-up weight range is 11500–13500 lb\* (5220–6120 kg) and propulsion is by a single free-turbine engine producing 1560 s.h.p. (1160 kW). The aircraft is fitted with a Bendix Pacific AQS 13 sonar system for ASW work. To facilitate handling and allow transition and ASW sonar search manoeuvres to be performed, an automatic flight control system is fitted. Automatic transition manoeuvres enable the aircraft to come to the hover at a preselected height from cruising flight (or vice-versa) and a sonar search is performed by dunking the sonar transducer (also known as the "ball") into the water. During this phase the aircraft's plan position is automatically controlled to hold the ball as still and upright as possible in the water.

The work described here stems from a Royal Australian Navy (RAN) requirement for ARL to develop a control and stability mathematical model of the Sea King Mk.50 helicopter, with special emphasis on behaviour in the sonar-dipping role. As a starting point for the Sea King study, a mathematical model of the Wessex helicopter, developed by T. J. Packer of Weapons Research Establishment† (WRE), was first set up on the ARL computer. Because the aerodynamics/kinematics and cable parts of the model are similar for the two helicopters, this eased the task of formulating the Sea King model. Packer also constructed a computer program of his Wessex model,<sup>1</sup> written in SIMTRAN II simulation language, for use on an IBM 7090 computer. The ARL Wessex program is essentially a reconstruction of the WRE Wessex program using a different simulation language, CSMP-10 (ARL), so that it can be used on a different computer, namely the PDP-10 machine at ARL. The program described here has further potential value in supporting continued service use of the Wessex.

The computer program can be subdivided into parts representing the helicopter aerodynamics/kinematics, automatic flight control system (AFCS) and sonar cable/transducer. Reference 2 describes the mathematical model for the aerodynamics/kinematics, while reference 3 describes the model for the sonar cable and transducer. Because no details of the AFCS have currently been published, block diagrams, supplied by T. J. Packer are included here (Appendix I) as background material to certain sections of this document. In addition to the above parts, the WRE version contains a pilot model which is only partly retained in the ARL version.

The aerodynamics/kinematics part of the program is a representation of the Wessex helicopter aerodynamics/kinematics, in six degrees of freedom, for low-speed flight such as occurs in automatic velocity–altitude transitions carried out in ASW operations. The AFCS section of the program contains detailed models of the flying controls, autostabilizer and hover coupler. The sonar cable and transducer part of the program calculates the forces due to air and water acting on the cable and transducer, when suspended from the helicopter and also estimates the shape of the cable and the motion of the cable/transducer. Descriptions of the above parts of the program are given in Section 2, while Sections 3 and 4 are concerned with program operation and validation respectively.

---

\* Because the model is a reconstruction of the WRE Wessex model, the same (Imperial) units have been used in the program.

† Now Defence Research Centre, Salisbury.

## 2. PROGRAM DESCRIPTION

This section gives descriptions of the elements of the ARL Wessex computer program. The program is written in CSMP-10 (ARL), which is a block-oriented simulation language; i.e. it is expressed in coded form with the aid of an analog computer type of block diagram, comprising a number of linked modules (called blocks), each one representing a particular function or operation (e.g. integration, addition, gain). The language incorporates "user-defined" blocks, written as Fortran subroutines, which enable complex algebraic expressions to be handled conveniently. A large number of outputs may be defined within these subroutines by using "dummy" or "user-output" blocks. Thus, the Wessex program can be summarized as comprising the following major parts:

- (i) The block-oriented part;
- (ii) The user-defined subroutines containing the aerodynamics/kinematics, control systems and cable/transducer;
- (iii) Data.

Fig. 1 illustrates the overall form of the program and a description of the simulation language is given in references 4 to 7. All parts of the program are well documented with comment lines.

### 2.1 The Block-Oriented Part (WECRU.MOD)

The CSMP modelling program (BOMMP) allows the mathematical model to be represented by control parameters and three types of statement, viz. configuration, parameter and function statements. The configuration statements describe the blocks used and specify the way in which they are linked together; each statement consists of a block number, a block type (e.g. integrator, adder) and a list of which other blocks (up to three) supply a block with input signals. Labels and comments are used for identification purposes. The parameter statements specify numerical values of parameters associated with the configuration statements, such as integrator initial conditions, while function statements specify co-ordinate pairs used to generate a function.

The subroutines for aerodynamics, control systems and cable are each specified as user-defined blocks in the configuration statements and the outputs from these subroutines are specified either as the principal output of the appropriate user-defined block or as its supplementary outputs in user-output blocks.

### 2.2 The Aerodynamics Subroutines (WEAPAK)

WEAPAK, which calculates the forces and moments acting on or about the centre of gravity of the helicopter and from these computes the helicopter motions, comprises:

- (i) User-defined subroutine USER 3, which is referenced by its associated user-defined block in the configuration statements;
  - (ii) Subroutine IMPLIC, called by USER 3.
  - (iii) Interpolation function F, called by USER 3.
- Data for WEAPAK are stored in file WEADAT.

The control inputs to WEAPAK are lateral cyclic blade pitch (AIS), longitudinal cyclic blade pitch (BIS), main rotor collective blade pitch (THETA C) and tail rotor collective blade pitch (THETA T). Outputs from WEAPAK include linear and angular accelerations, velocities and positions of the helicopter and rotor information.

### 2.3 The Control Systems Subroutines (WESPAK)

WESPAK, which calculates the action of the control systems (hover coupler, autopilot and flying controls), consists of:

- (i) User-defined subroutine USER 2, which is referenced by a user-defined block in the configuration statements;
  - (ii) Function FSWAP, called by USER 2;
  - (iii) Function ROTATE, called by USER 2.
- Data for WESPAK are stored in file WESDAT.

The main outputs from WESPAK are the derivatives of the cyclic blade pitch angles, from which the blade pitch angles AIS and BIS are determined by integration and the main and tail rotor collective blade pitch angles (THETA C and THETA T respectively). AIS, BIS, THETA C

and THETA T are supplied to the aerodynamics subroutines WEAPAK. Inputs to the control systems subroutines include helicopter attitude angles, linear and angular velocities and altitude, together with cable attitude and length information.

#### 2.4 The Cable Subroutines (WECPAK)

WECPAK, which calculates the forces acting on the cable and transducer when suspended from the helicopter and estimates the shape and motion of the cable, comprises:

- (i) User-defined subroutine USER 4.
- (ii) Subroutines PREDIP, CABLE and FUNNEL called by the aerodynamics subroutine WEAPAK.
- (iii) Subroutines TNSION and FLUID called by subroutine CABLE.
- (iv) Function S CABLE also called by CABLE.

Data for WECPAK are stored in file WECDAT and are called for by subroutines CABLE and FUNNEL.

The structure of WECPAK is shown in Fig. 2 and the theoretical development for the mathematical model of the sonar cable and transducer is described in ref. 3.

### 3. PROGRAM OPERATION

This section describes how specific flight manoeuvres can be set up using the program outlined in Section 2. The stages are:

- (i) Calculate the initial conditions of the model.
- (ii) Specify the operating instructions.
- (iii) Load the relocatable binary files of the CSMP-10 (ARL) modelling program (BOMMP.REL and DUSER.REL) and the relocatable binary form of the user-defined files (WEAPAK.REL, WESPAK.REL and WECPAK.REL) into the computer core and save a core image of the resulting modelling program.
- (iv) Execute the program; this results in the creation of a file containing program output data.
- (v) Produce graphical and/or tabular output from the output data file.

As the procedure for performing operations (iii), (iv) and (v) is described in detail in refs 4, 5 and 7, it is not included here.

#### 3.1 Setting Up a Flight Manoeuvre—Initial Conditions

It is usual to run the model from a steady-state condition, usually that of trimmed, level flight. To do this, the initial conditions of all integrator, first-order lag and delay blocks must be determined. The definition of the steady-state condition is:

$$\dot{u}_{HEH} = \dot{v}_{HEH} = \dot{w}_{HEH} = 0 \quad (3.1)$$

$$\dot{p}_{HEH} = \dot{q}_{HEH} = \dot{r}_{HEH} = 0 \quad (3.2)$$

$$p_{HEH} = q_{HEH} = r_{HEH} = 0 \quad (3.3)$$

and

$$v_{HEH} \approx w_{HEH} \approx 0. \quad (3.4)$$

In these equations,  $u_{HEH}$ ,  $v_{HEH}$  and  $w_{HEH}$  are the linear velocity components of the helicopter, relative to the earth, in helicopter axes, in the longitudinal ( $x$ ), lateral ( $y$ ) and vertical ( $z$ ) directions respectively.<sup>2</sup> Similarly,  $p_{HEH}$ ,  $q_{HEH}$  and  $r_{HEH}$  are the components of angular velocity about the  $x$ ,  $y$  and  $z$  axes. In this flight condition the Wessex normally is pitched slightly nose-up and rolled slightly port-side down, so that  $v_{HEH}$  and  $w_{HEH}$  are non-zero; however, it is sufficiently accurate for the present purpose to treat them as zero.

Normally, when the pilot is flying the aircraft in a steady cruise, the autopilot and barometric altimeter are engaged and the hover coupler is disengaged. The standard file, WECRU.MOD, contains all initial conditions for this case, with the aircraft at 120 ft (36.6 m) altitude and a forward velocity of 68 ft/s (40 knots). A satisfactory procedure for obtaining initial conditions at different forward velocities is outlined below:

- (i) Use the standard version of WECRU.MOD to perform a transition-down manoeuvre (see Section 3.2.2).
- (ii) Use the results from this run to obtain values of the following variables at the desired forward velocity:

THE HE (block 3)	OLD THETA C (block 43)
PHI HE (block 4)	OLD THETA T (block 44)
U HEH (block 8)	BIS (block 75)
OLD FCT (block 15)	AIS (block 76)
OLD LMT (block 20)	THETA C (block 149)
OLD MUT (block 21)	THETA T (block 158)
OLD CTT (block 22)	

- (iii) Use the control systems block diagrams (Appendix I) to calculate the values of all relevant initial conditions in the automatic flight control system (AFCS) corresponding to AIS, BIS, THETA C and THETA T specified above. Assume that the AFCS is in equilibrium; i.e. if the rotor settings are to remain constant, then the voltages and displacements giving rise to these settings must also remain constant.
- (iv) Replace the values in the parameter statements of WECRU.MOD with those obtained in steps (ii) and (iii) above and rerun the model to perform a steady flight manoeuvre (no transition). The desired altitude is achieved by setting the parameter of block 14 (Z HEE) appropriately.
- (v) Make fine adjustments to the stick and pedal positions to trim the aircraft at the desired forward velocity. This may involve a number of trial runs.

### 3.2 Setting Up a Flight Manoeuvre—Operating the Model

Having set up the model so that it is in steady flight, the next stage is to “fly the helicopter.” To do this it is necessary to be able to:

- (i) Engage the autopilot and barometric height hold.
- (ii) Engage the hover coupler.
- (iii) Drop the cable and sonar transducer.
- (iv) Alter the pilot's controls (i.e. cyclic and collective sticks and rudder pedals).
- (v) Incorporate wind gusts and water currents.

The following sections should be read in conjunction with the program and Appendix I.

#### 3.2.1 Engaging the Autopilot and Barometric Height Hold

Essentially the autopilot is engaged by switch S AUTO and the barometric height hold by switch S BAR A. The relevant instructions are:

- (i) In the block-oriented part of the program:

```

87 K      ; S AUTO
88 Z 113 96; S BAR A
96 K      ; 1.0
113 K     ;

```

- (ii) In WESPAK:

S AUTO = C(12 + 4).GT.0.

S BAR A = C(12 + 5).GT.0.

If the quantity 1.0 is stored in the parameter statement for block 87, S AUTO will be engaged. If block 87 contains 0, S AUTO will be disengaged. In the pitch and roll channels, S AUTO alone engages the autopilot, but the yaw channel is only engaged by S AUTO if the pilot does not have his feet on the pedals; i.e. S PEDLS is off (Fig. A7). For control of S PEDLS, see Section 3.2.4.1. To engage the altitude channel (i.e. the barometric height hold), both S AUTO and S BAR A must be switched on (Fig. A6). In this mode, the “set height” is H BAR A. If the switch S BAR A is off, the set height is the actual height, so that the error (difference between the set and actual heights) is zero. If S BAR A is on, the set height is the

height at the time when S BAR A is engaged. The operation of the Z-block representing S BAR A is described in Ref. 4; switching is determined by the parameter values for blocks 88, 96 and 113.

### 3.2.2 Engaging the Hover Coupler (for transition-down and hovering manoeuvres)

The cyclic channels (pitch and roll) of the hover coupler are engaged by switch S HOVCY and the altitude channel by switch S HOV A. The relevant instructions are:

(i) In the block-oriented part of the program:

84 K; S HOVCY

86 K; S HOV A

(ii) In WESPAK:

READ (N READ, 1) CPY1, ----, T TRANS, H HOVER, H DOWN, DELTA H

┆  
┆  
┆

S HOVCY = C(12 + 1).GT.0.0

S HOV A = C(12 + 3).GT.0.0

where T TRANS is the time at which the transition to the hover begins, H HOVER is the intended hovering height and H DOWN and DELTA H are parameters used in the transition-down manoeuvre. The constants T TRANS, H HOVER, H DOWN and DELTA H are contained in data file WESDAT and must be specified by the user.

The program automatically ensures that S HOVCY and S HOV A are initially disengaged and engages them at the user specified value of T TRANS. The transition-down manoeuvre to the user specified hover height is then performed automatically. Note that additional programming is required if S HOVCY and S HOV A are subsequently switched off.

During the transition-down manoeuvre, the input to the altitude channel, the set radio altimeter height (H SET RA), needs to vary from the height at the entry gate (i.e. when transition-down starts) to the intended hovering height. This is achieved in two stages. First, in the descent from the initial height to the intermediate height (H DOWN), a step function input is used. Second, in the height range H DOWN to H HOVER, the set radio altimeter height is kept about 20 ft (DELTA H) below the actual aircraft height until H HOVER is reached. The manoeuvre is programmed in WESPAK. Note that H HOVER must not be less than 35 ft.

### 3.2.3 Dropping the Cable and Sonar Transducer ("Ball Drop")

To initiate a ball drop, it is necessary to:

(i) Establish the helicopter in a hover at the correct height with the hover coupler switched on.

(ii) Specify a value for the ball drop start time, TIM DRP.

At the finish of the transition-down manoeuvre, the hover coupler will remain switched on and the helicopter will normally be in a near hover condition. However, safeguards are built into the program to ensure that velocity and height at hover are within certain limits (the S DROP V and S DROP H criteria). If desired, these tolerances can be altered by the user by changing the values of V TOL CB and H TOL CB in file WEADAT. The value for TIM DRP is also contained in WEADAT.

The user may, in addition, change the length of cable paid out by entering different values for the vector quantity ELS, which contains the lengths of the individual "links" in the mathematical model of the cable. The sum of these values is the total length of the cable. NL is the number of links and ELS (1) must be zero. Data values must again be changed in WEADAT.

When the ball has dropped and the cable has become taut, the hover coupler is switched from Doppler to cable mode. This is included in the programming and does not require attention from the user. To discontinue the simulation of the ball drop, further coding is required.

### 3.2.4 Alteration of the Pilot's Controls

#### 3.2.4.1 Rudder Pedals

The relevant instructions in the configuration statements are:

```
81 I 155 97 89; D PEDLS
89 K           ; S PEDLS
97 K           ; ZERO
155 UO 115    ; D PED DT
```

S PEDLS is a switch, on the rudder pedals, which is turned on by the pilot before he may move the pedals (Fig. A12). The displacement of the pedals is represented by the output of the integrator D PEDLS. When S PEDLS is on and the pilot is operating the pedals, D PEDLS is continually being reset to its initial condition, D PILDY. Pilot control of the rudder pedals must therefore be programmed by:

(i) Turning on S PEDLS by setting the parameter value for block 89 to 1.0.

(ii) Updating D PILDY by adjustment of the parameter value for block 81.

An example of how the pilot might operate the pedals is given in WESPAK.

When S PEDLS is off (parameter values for block 89 set to zero), the pedal position may still be adjusted through autopilot action; these automatic adjustments are computed in WESPAK and output in the variable D PED DT, the input to the D PEDLS integrator.

#### 3.2.4.2 Collective Stick

The relevant instructions are:

(i) In the configuration statements;

```
90 K; S PIL A
```

(ii) In WESPAK;

```
S PIL A = C(12 + 7).GT.0.
```

and

```
TCS D PL = 0.
```

The user who wishes to include a pilot movement of the collective stick must therefore turn on S PIL A by setting the parameter value of block 90 to 1.0 and supply a value of TCS D PL (Fig. A11) by overwriting the above statement in WESPAK. When the stick movement is completed, S PIL A should be turned off (block 90 parameter set to zero). Some indication of the sort of movement desirable is given in Ref. 1.

#### 3.2.4.3 Cyclic Stick

The relevant instructions are:

```
61 I 138 97 104; THE STK
62 I 139 97 104; PHI STK
95 K           ; STRM RL
96 K           ; 1.0
97 K           ; ZERO
104 Z 95 96    ; STK RST
138 UO 115     ; THE TDT
139 UO 115     ; PHI TDT
```

Making a control movement of the cyclic stick is similar to making a control movement of the rudder pedals. The user must (Figs A8 and A9):

(i) Switch on the trim release switch STRM RL by setting the parameter value of block 95 to 1.0.

(ii) Update THE PIL and/or PHI PIL to their new values.

These instructions set the cyclic stick integrators to the reset mode so that their outputs (THE STK and PHI STK) take on the values demanded by the pilot (THE PIL and PHI PIL). No coding is included in WESPAK to perform these operations; coding would be similar to that outlined in Ref. 1.

Small cyclic stick movements in either pitch or roll may be made by using the pilot's beeper trim switches (S AFT, S FWD, S STBD and S PORT—blocks 91 to 94 in the configuration statements and the associated input statements in WESPAK). Switches are off if a value of zero is stored in the appropriate parameter block and are on if the stored value is 1.0. The angle through which the cyclic stick is moved is proportional to the time for which the beeper switch is on and in the model is controlled by means of constants CCP1 and CCR1 in pitch and roll respectively as shown in Figs A8 and A9. The switches are effective only if S HOVCY is off. If this is on, then the hover coupler itself takes over control of the beeper switches (Figs A1 and A2).

### 3.2.5 The Incorporation of Wind Gusts and Water Currents

#### 3.2.5.1 Wind Gusts

Wind data are supplied to the program via the parameters V WE, PSI WEE and W WEE. V WE and PSI WEE are, respectively, the magnitude and direction of the wind relative to the earth in earth axes, in a horizontal plane and W WEE is the vertical magnitude component. As the coding stands, PSI WEE and W WEE are constants which are specified in data file WEADAT and called in WEAPAK. V WE is specified as a wind of time-dependent velocity through an F block in the configuration statements and the co-ordinate pairs table in its associated function statement.

#### 3.2.5.2 Water Currents

Water current data are read into WEAPAK via the read-in statements for UFCO, VFCE, UFCZ and VFCZ (data values are contained in file WEADAT) and these are transferred to the control systems and cable subroutines by means of a common statement. UFCO and VFCE are components of linear velocity of the fluid, relative to the cable, at the fluid surface, in the horizontal plane and UFCZ and VFCZ are the corresponding velocity/depth parameters.

## 4. PROGRAM VALIDATION

Validation of the ARL model consisted of a comparison with the WRE model. The WRE model has itself been validated with respect to the Wessex helicopter/sonar cable and transducer through flight trials work.<sup>8</sup> However, some differences appeared between the two programs and these are outlined in Section 4.1. It should be noted that for validation purposes, the ARL and WRE versions were made identical, but the corrections detailed in Section 4.1 have been incorporated in the standard version of the ARL program. Section 4.2 presents some sample results using the ARL version and comments on them. Direct comparison of results from the two models for typical variables is also given. Since program validation, some inconsistencies have been found in the original analysis of the cable model and appropriate changes are given in Section 4.3.

### 4.1 Differences Between the ARL and WRE Programs

The ARL program differs from the WRE program published by Packer and Lane<sup>1</sup> in the following ways:

- (i) A discrepancy exists between the theoretical development<sup>2</sup> of the expression for  $OMG \cdot DOT$ , the main rotor angular acceleration and the expression written in the WRE program. The analysis given in Ref. 2 appears correct and is used in the ARL version.
- (ii) In the WRE program, the Doppler damping term,  $V \cdot DAMPA$ , includes the expression  $W \cdot HEH + (CHA23 \cdot U \cdot HEH)$ , where  $CHA23 = 0$ . Theoretically, the correct value for  $CHA23$  is  $-\sin(\theta_{HE})$ ; using this, the above expression very nearly corresponds to the velocity,  $W \cdot HEE$ . The term  $W \cdot HEE$  is used in the ARL program.
- (iii) A value for the ball sink time ( $T \cdot SINK$ ) of 0.5 s is used in the ARL program. The value of 10.0, used by the WRE version, means that control by the cable is delayed for 10 s. While this may be reasonably realistic in practice, it is rather wasteful of computing time. Also and more importantly, the characteristics of the velocity control system are such as to allow the aircraft to fly backwards at up to 10 ft/s (the actual

- value depends on the conditions at ball drop) during the 10 s ball sink period. This drags the ball along with large cable deflections which can cause an erroneous cable height to be calculated, indicating that the aircraft is above the hover height. This, in turn, calls for a control system height reduction which causes the aircraft to exceed the height tolerance (H TOL CB) thus switching off the cable height signal; control then reverts to the radio altimeter mode. To overcome these effects, the value of H TOL CB was increased and a value of 0.5 s was used for T SINK. However, it is disturbing to note that the velocity control is not more rapid in bringing the aircraft to a hover. In practice, it is possible that the pilot may trim the aircraft in hover, thus alleviating the effect (the decision to drop the ball is left to the judgement of the pilot).
- (iv) A value for CHA5 of 0.285 is used in the ARL program rather than the WRE value of 0.33. It was found that the WRE value for CHA5 was such that, even when the cable height was at the set cable altitude, a non-zero error voltage, VERR A, occurred (see Fig. A3). Therefore, it was decided to adjust CHA5 to make VERR A = 0 under these conditions.
  - (v) The ARL version includes an expression for variable STORE in the cable subroutines. This enables the program to agree with the theoretical model described in Ref. 3. For reasons unknown, the WRE version does not have this term included. The modification affects motion of the cable.
  - (vi) In order to conform to the set radio altitude (H SET RA) defined by TBL HRA in the WRE program, the statement H SET RA = 120.0 is used in the ARL version for validation purposes. In further running of the ARL program, the more general statement H SET RA = Z ON COS should be used.
  - (vii) The expression for helicopter pitching moment,  $M$ , (see equation (150) of Ref. 1) contains a term arising from the rotor H-force component in helicopter axes,  $C_{H_H}$ . This has been used by ARL rather than  $C_{H_S}$  which appears in the WRE program.<sup>2</sup> The WRE approximation is not always sufficiently accurate.

#### 4.2 Sample Results and Comments

Fig. 3 shows the time histories of some of the main variables for a run using the ARL program and having the following features:

- (i) Initial conditions; near-steady flight at a forward velocity of 68 ft/s (40 knots), altitude 120 ft (37 m).
- (ii) Transition to hover at 35 ft (11 m) altitude begun at 5 s.
- (iii) Ball drop begun at 50 s; sink time 0.5 s.
- (iv) Wind gusts rising from zero to 35 ft/s (20.7 knots) in 1 s beginning at 79 s, duration 5 s.
- (v) Run terminated at 120 s.

When the ARL and WRE programs are made consistent as outlined in Section 4.1 the results of a two minute flight simulation agree closely although not exactly. This is demonstrated for six typical variables in Fig. 4, where the differences between the outputs of the two models are also plotted on enlarged scales. In each instance the differences vary considerably with time, in some cases fluctuating periodically about a mean of zero, but always remaining comparatively small, and with no trace of cumulative differences even after two minutes' flight. It is believed that such deviations arise from differences in integration routines and computer round-off errors. Compared with the differences to be expected between actual flight measurements and simulated flight they are quite negligible.

The presence of steady state oscillations in some variables should also be noted. This phenomenon occurs in both the ARL and WRE programs and may represent an instability in the program which is not present in the aircraft.

While good agreement has been achieved between the two programs, there are some additional improvements which may be worthwhile including in the program. These are:

- (i) Modification of the transition program to conform to Flight Information Publication (FLIP) procedures, where the velocity transition leads the height transition by approximately 5 s.
- (ii) Modification of the stick friction statement in the collective stick model. With the stick stationary, friction should affect external torque.

- (iii) Strictly, for level flight,  $W_{HEE}$  and not  $W_{HEH} = 0$  (see Section 3.1). The value of  $W_{HEH}$  should be calculated and used as the initial condition for block 10 in the parameter statements.
- (iv) Modification of the drag coefficient values for the ball in the cable data to be consistent with Ref. 3, or preferably with new data currently being acquired in the ARL low speed wind tunnel.

### 4.3 Cable Model Changes Since Validation

#### 4.3.1 Drag Force Components

The lateral drag force  $x$  and  $y$  components (in bottom of link axes) acting on a cable link were incorrectly derived in Ref. 3 (see equations (35) and (36)). Simplifying the notation here, the force components  $X$  and  $Y$  are given in Ref. 3 by expressions of the form:

$$X = ku|u|$$

$$Y = kv|v|$$

where  $k$  is a drag constant (proportional to the lateral drag coefficient) and  $u, v$  are the  $x, y$  components of the fluid velocity relative to the cable link. It can be seen that the force components have been obtained by first resolving velocity. To correspond to the use of a lateral drag coefficient, drag force in the resultant lateral direction of flow should have been determined first, i.e.:

$$F = kV^2$$

where  $F = (X^2 + Y^2)^{1/2}$  and  $V = (u^2 + v^2)^{1/2}$ .

This force should then be resolved in the  $x$  and  $y$  directions to give:

$$X = kuV$$

$$Y = kvV.$$

It should be noted that longitudinal drag for each link is neglected. A similar error was made in deriving equations (56) and (57) of Ref. 3 for the fluid forces acting on the transducer.

#### 4.3.2 Tension Equation Approximations

In equation (15) of Ref. 3, the tension forces in the  $z$  direction on the top and bottom ends respectively of the  $n$ th link, resolved in  $n$ th link axes are given by:

$$Z_{TTL_n} = T_n - T_{n-1}$$

$$Z_{TBL_n} = T_{n+1} - T_n$$

where  $T_1, \dots, T_N$  are the mean tension forces in the respective  $N$  cable links. These expressions were obtained on using small angle approximations for  $\theta_{LB_n}$  and  $\phi_{LB_n}$ , the pitch and roll Euler angles respectively of the tangent to the cable at the  $n$ th point mass with respect to the  $n$ th link axes system. Prior to making these approximations, the tensions  $Z_{TTL_n}$  and  $Z_{TBL_n}$  are given by:

$$Z_{TTL_n} = T_n - T_{n-1} \cos 2\theta_{LB_{n-1}} \cos 2\phi_{LB_{n-1}}$$

$$Z_{TBL_n} = T_{n+1} \cos 2\theta_{LB_n} \cos 2\phi_{LB_n} - T_n.$$

Although angular deviations between adjacent links may generally be small, for significant relative motion between the cable and environment, the accumulated angular deviation over the entire cable length may be quite large. Where this was the case, the effect of ignoring an accumulation of small errors has been found to produce significant errors in the estimated cable shape. Hence second order terms are now retained in the cosine series approximations e.g.:

$$\cos \theta_{LB_n} \approx 1 - \frac{1}{2}\theta_{LB_n}^2$$

The tension force equations then become:

$$Z_{TTL_n} = T_n - T_{n-1} [1 - 2(\theta_{LB}^2 + \phi_{LB}^2)_{n-1}]$$

$$Z_{TBL_n} = T_{n+1} [1 - 2(\theta_{LB}^2 + \phi_{LB}^2)_n] - T_n.$$

Equations (16) and (11.1) of Ref. 3 may then be written as:

$$-a_n T_{n-1} + b_n T_n - c_n T_{n+1} = C_n \quad (\text{for } n = 1 \dots N \text{ with } T_0 = T_{N+1} = 0)$$

where  $a_n = -[1 - 2(\theta_{LB}^2 + \phi_{LB}^2)_{n-1}]/m_{n-1}$

$$b_n = -(1/m_n + 1/m_{n-1})$$

$$c_n = -[1 - 2(\theta_{LB}^2 + \phi_{LB}^2)_n]/m_n$$

$C_n$  is defined in Ref. 3 and  $m_n$  is the mass of the  $n$ th link ( $m_0 = 0$  and  $m_N = m_b$ , the ball mass).

The method of solving the recurrence relations given in Appendix II of Ref. 3 is insufficiently documented to allow easy modifications of the algorithm. Hence, a new algorithm is now used.<sup>9</sup> The new coefficients were found to improve the predicted shape of the cable for the case in steady high winds.

## 5. CONCLUDING REMARKS

The simulation language CSMP-10(ARL) has proved a viable means for programming the ARL version of the Wessex helicopter and sonar mathematical model. User defined subroutines have been used extensively throughout the program, which makes the ARL program in many ways similar to the equation oriented WRE SIMTRAN II program. The use of program TRANS, which forms part of the simulation language, has proved a particularly convenient means of producing graphical and tabular output data.

Perhaps the most difficult aspect of program operation is determining the initial conditions for starting a flight manoeuvre. While the procedure outlined in Section 3 has proved satisfactory for establishing steady level flight initial conditions, it is by nature a trial and error method which requires some knowledge of program construction. The difficulties in establishing initial conditions become greater when non-steady level flight manoeuvres are considered; for example, when setting up conditions for a co-ordinated turn. The incorporation of a pilot model similar to that used in the WRE program<sup>1</sup> may be useful for performing such manoeuvres.

The validation procedure relies on comparison of the ARL program with the WRE program; the assumption is made that the WRE program behaves in a similar manner to the Wessex helicopter. Although the WRE program has been verified using flight test results, a number of discrepancies have been found between the theoretical development of the model and the WRE program, which affect dynamic behaviour. While corrections (see Section 4) have been made to the ARL model to remove these discrepancies, no validation of the modified program with the helicopter has been attempted.

The behaviour of the model appears reasonable in most respects, although two features in particular should be questioned. First, the limit cycle oscillations which occur in some variables during hover may be due to program operation rather than aircraft/control system/cable characteristics. Second, the slowness of the Doppler velocity control in bringing the aircraft to a hover after a transition down gives cause for concern. These characteristics exist in both the ARL and WRE programs. Additional aircraft flight tests would be required to investigate these points.

## ACKNOWLEDGEMENT

The authors wish to acknowledge assistance given by the following:

Mr T. J. Packer, by providing details of the WRE Wessex model;

Dr D. C. Collis, the task manager for the project;

Mr P. G. Nankivell, with the simulation language.

## REFERENCES

1. Packer, T. J., and Lane, R. C., Wessex helicopter/sonar dynamics study. The system simulation program. WRE Technical Note 937 (WR & D), May 1973.
2. Packer, T. J., Wessex helicopter/sonar dynamics study. The mathematical model of the helicopter aerodynamics and kinematics. WRE Technical Memorandum SAD 203, November 1969.
3. Packer, T. J., Wessex helicopter/sonar dynamics study. The mathematical model of the sonar cable and transducer. WRE Report 951 (WR & D), May 1973.
4. Gilbert, N. E., and Nankivell, P. G., The simulation language CSMP-10(ARL). ARL Aerodynamics Note 362, May 1976.
5. Gilbert, N. E., and Nankivell, P. G., Further information for users of the simulation language CSMP-10(ARL). ARL Technical Note (to be published).
6. Gilbert, N. E., and Nankivell, P. G. An extended version of CSMP-10. Simulation, Vol. 29, No. 2, August 1977.
7. Nankivell, P. G., and Gilbert, N. E., A general purpose program for use in simulation. ARL Aerodynamics Note 367, December 1976.
8. Packer, T. J., Wessex helicopter/sonar dynamics study. Initial Report. WRE Technical Note SAD 216, January 1969.
9. Smith, G. D. Numerical solution of partial differential equations. Oxford University Press, 1965, pp. 20-22.

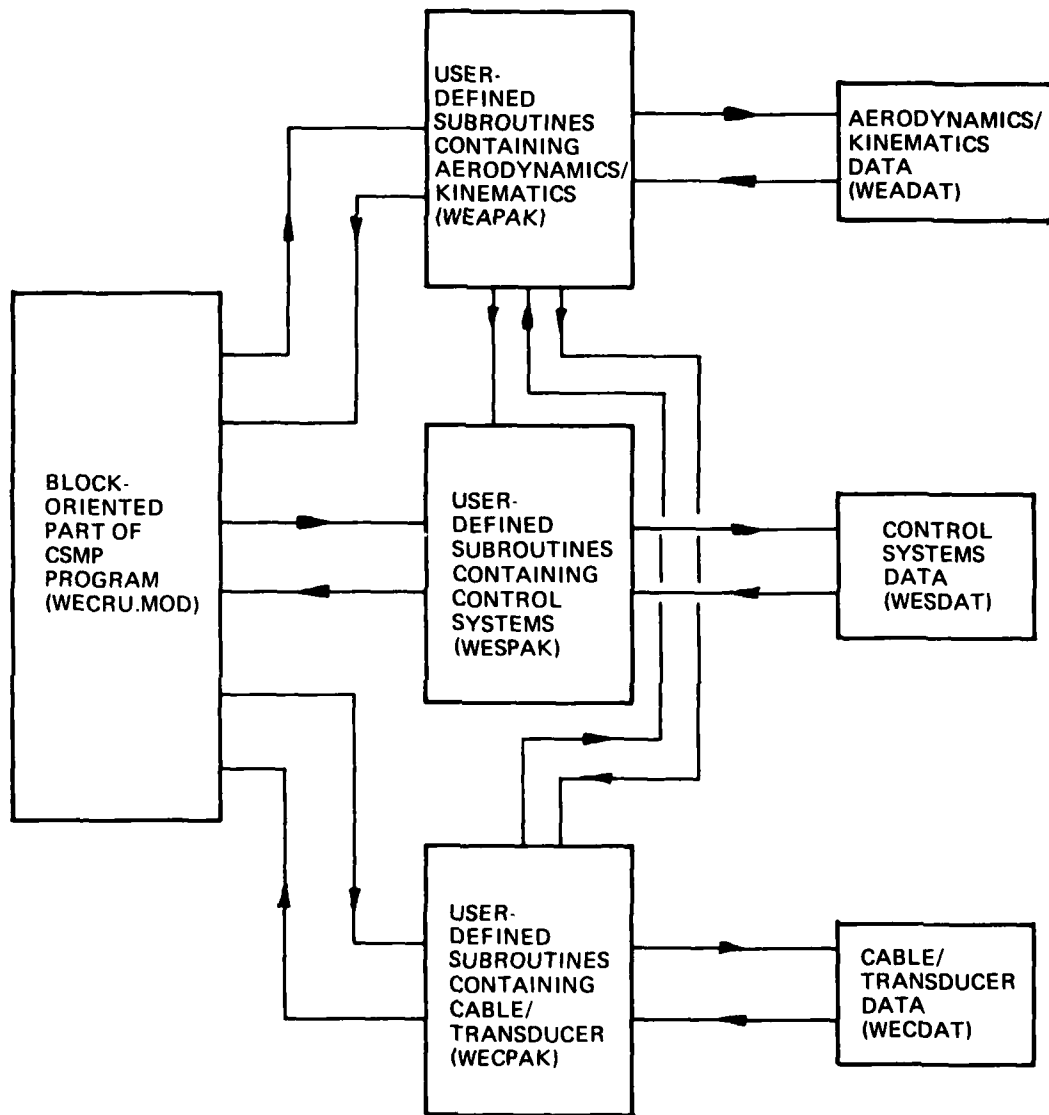

FIG. 1 OVERALL FORM OF WESSEX PROGRAM

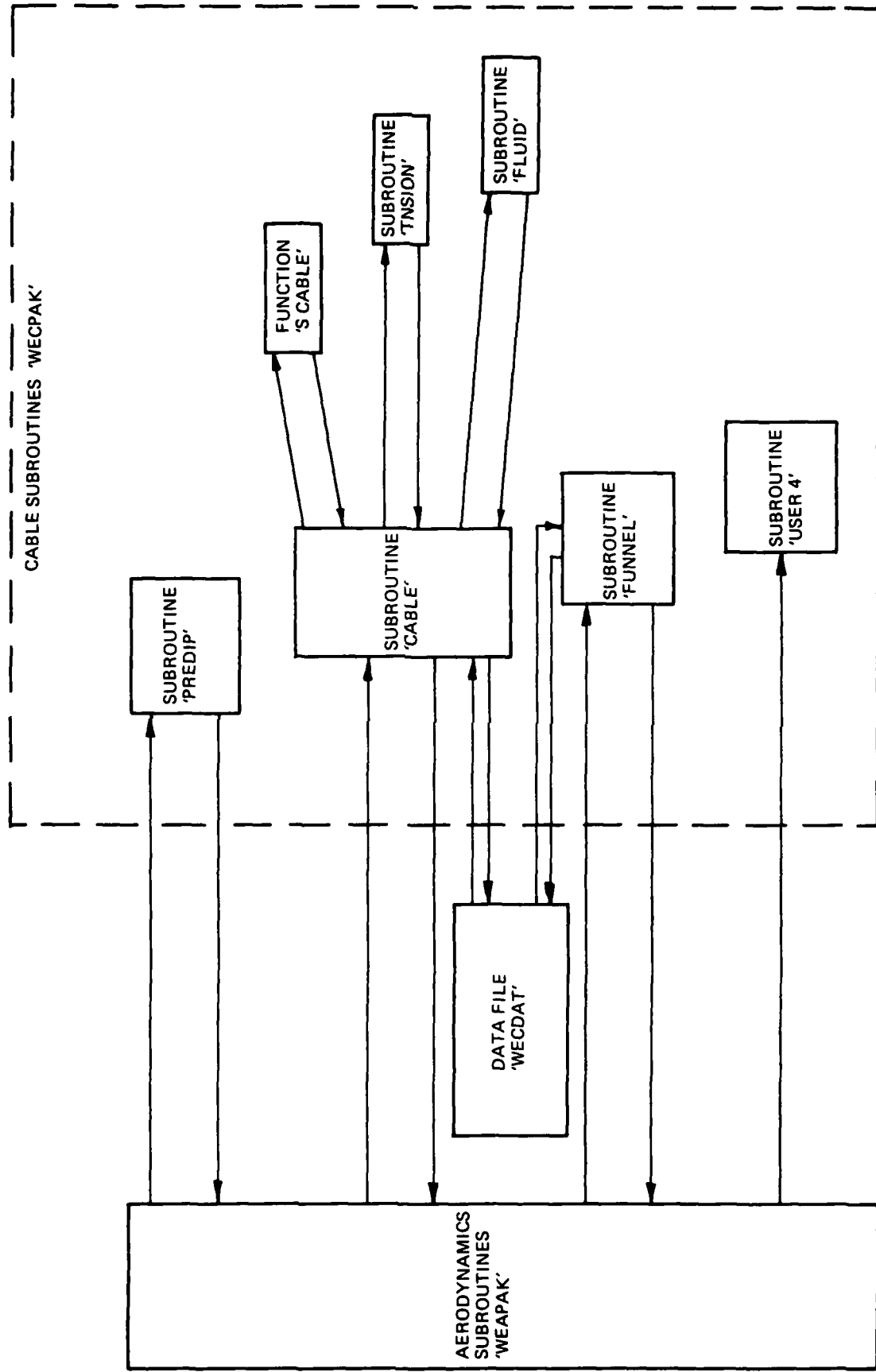
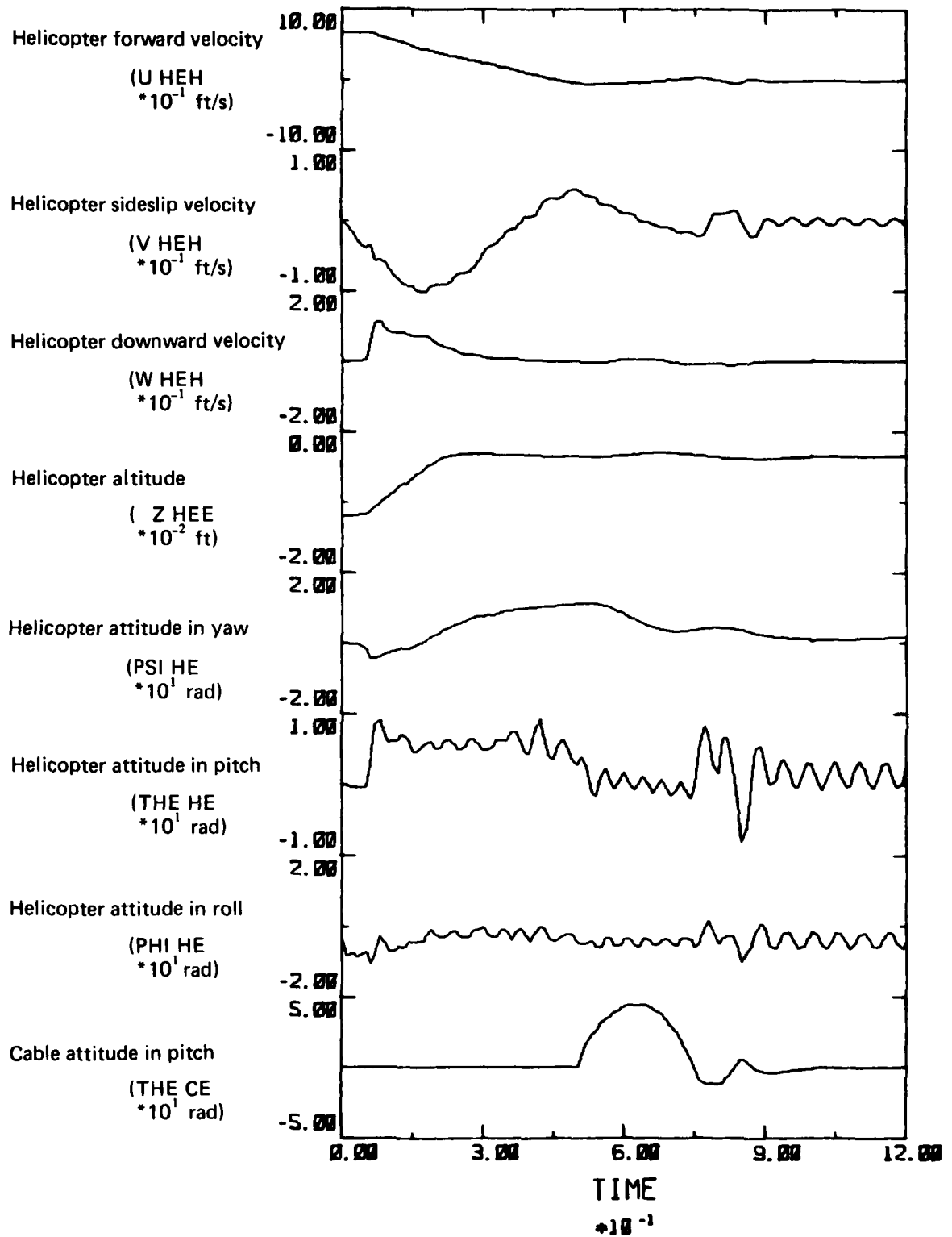
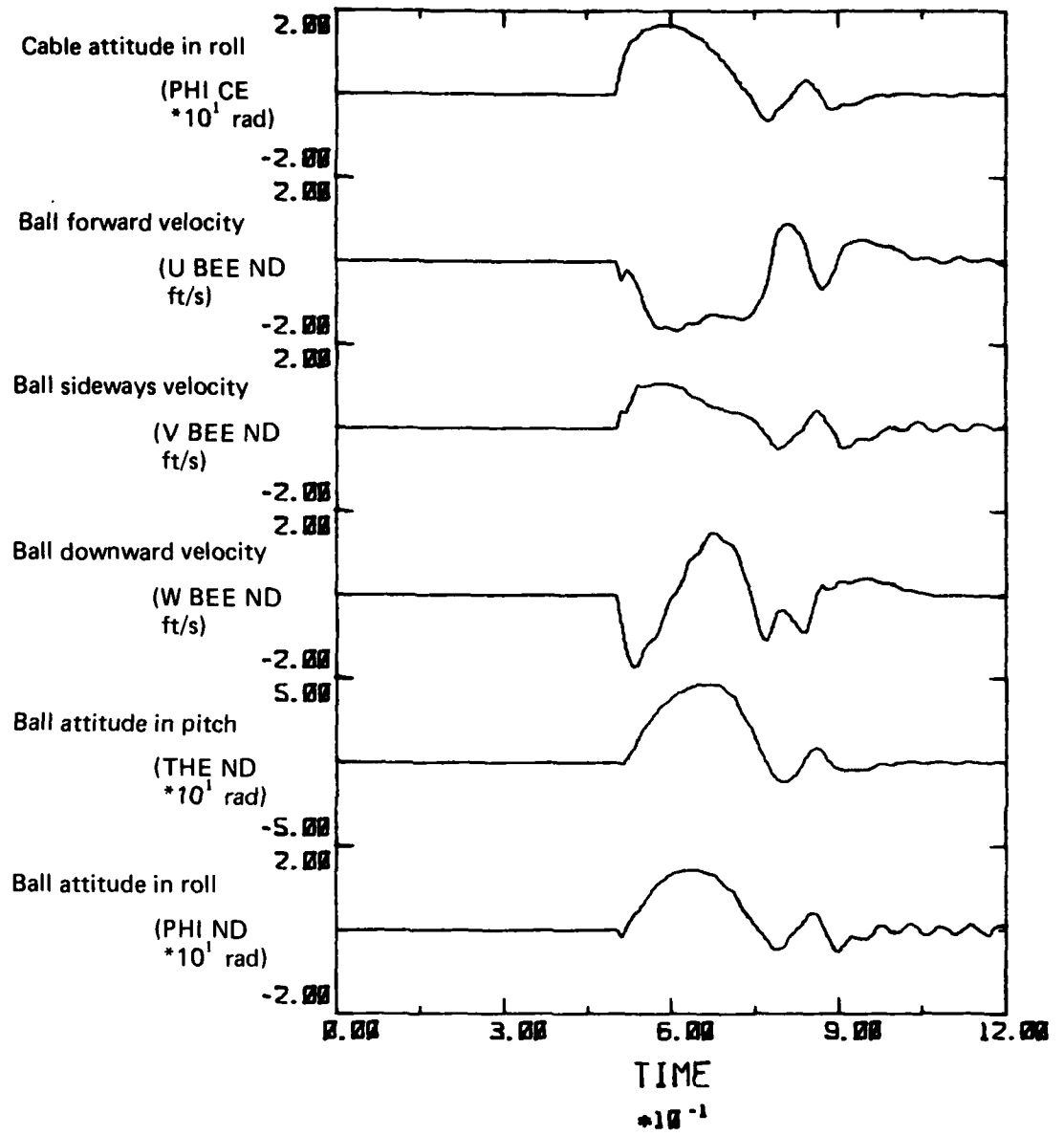

FIG. 2 STRUCTURE OF CABLE SUBROUTINES WECPAK



All variables (except time) are with respect to earth

FIG. 3(a) SAMPLE RESULTS



All variables (except time) are with respect to earth

FIG. 3 (b) SAMPLE RESULTS

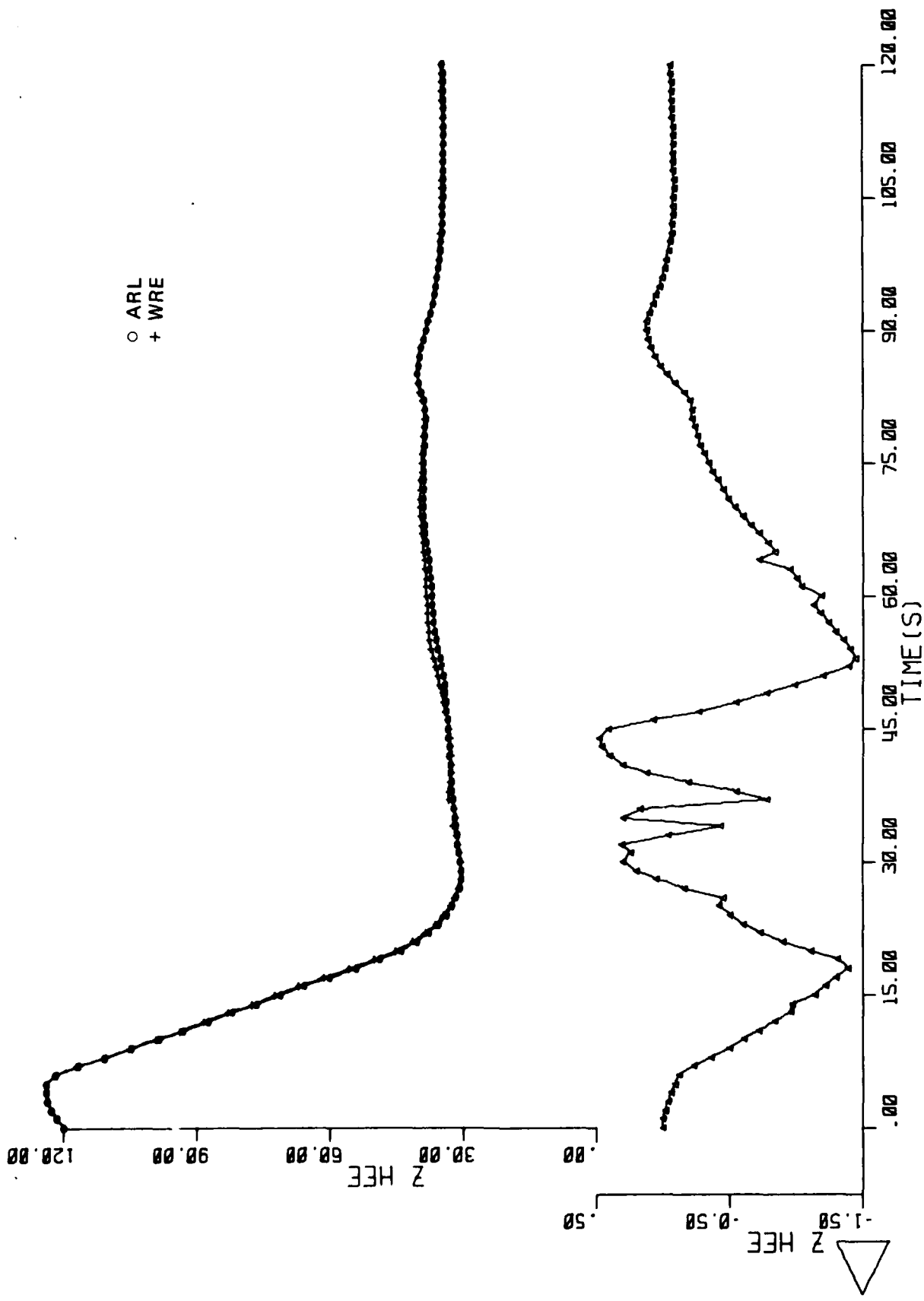

FIG. 4 COMPARISON OF RESULTS FROM ARL AND WRE MODELS  
(a) ALTITUDE, FEET

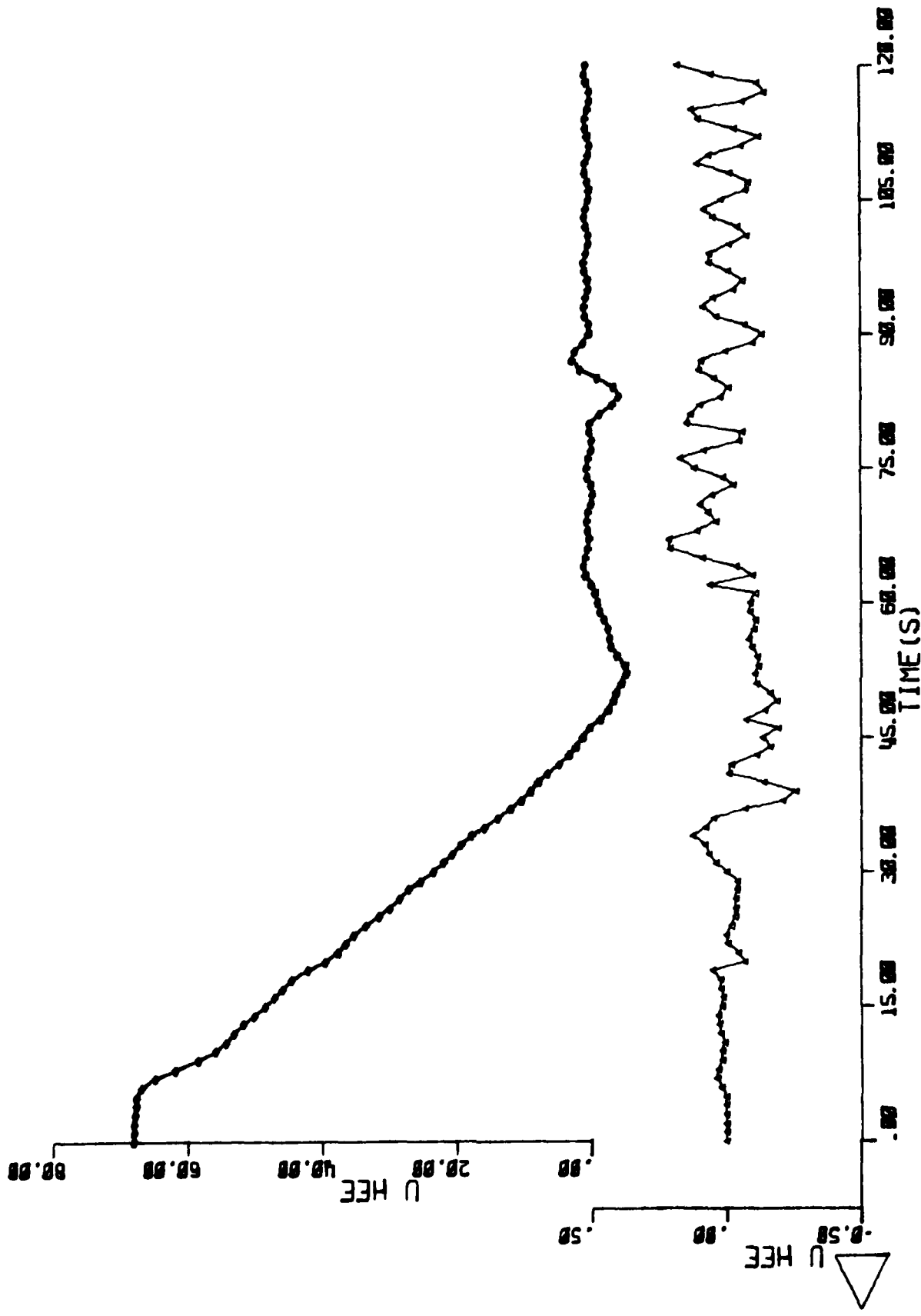

FIG. 4(b) LONGITUDINAL VELOCITY, FT/SEC

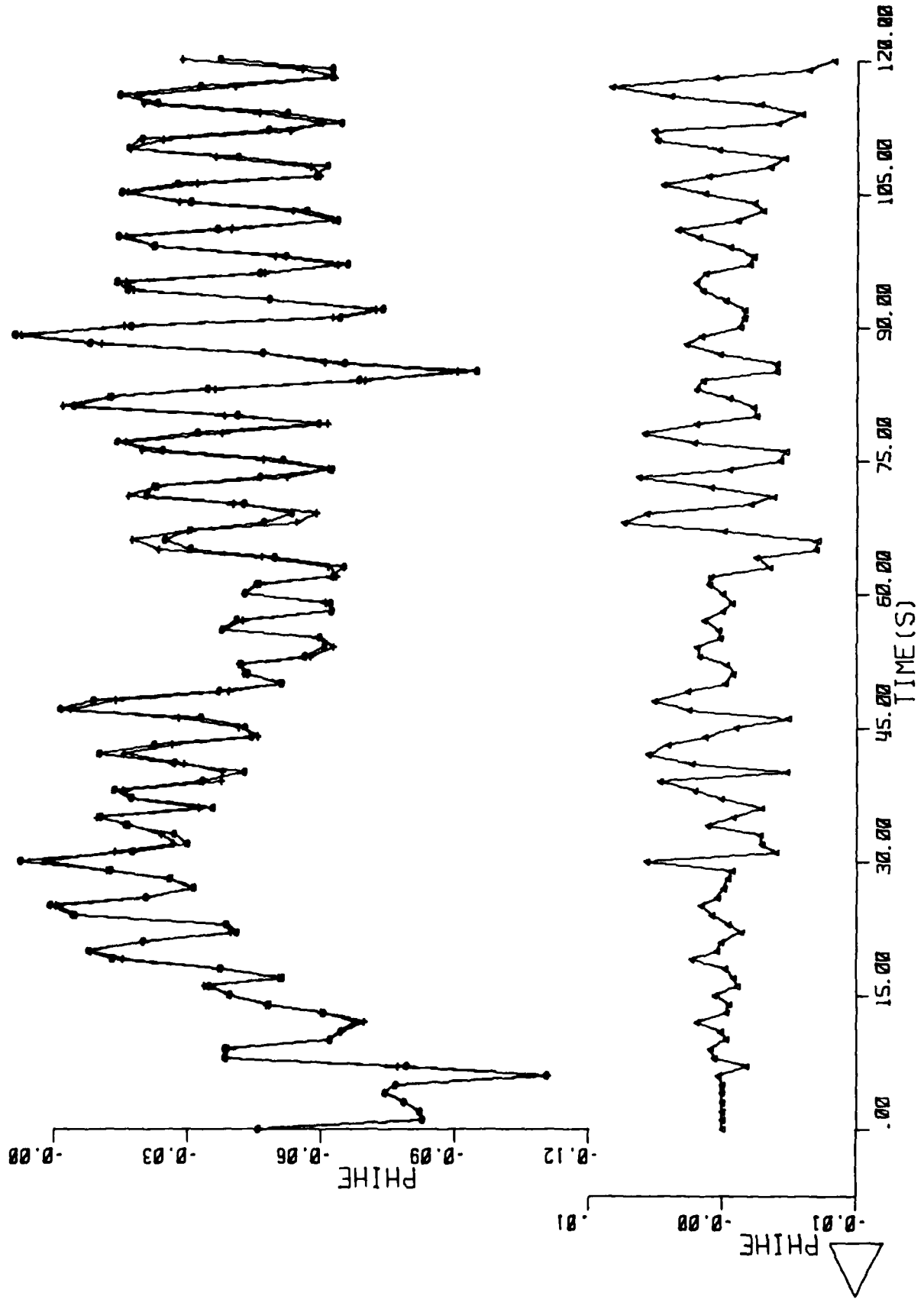

FIG. 4(c) ROLL ATTITUDE, RADIAN

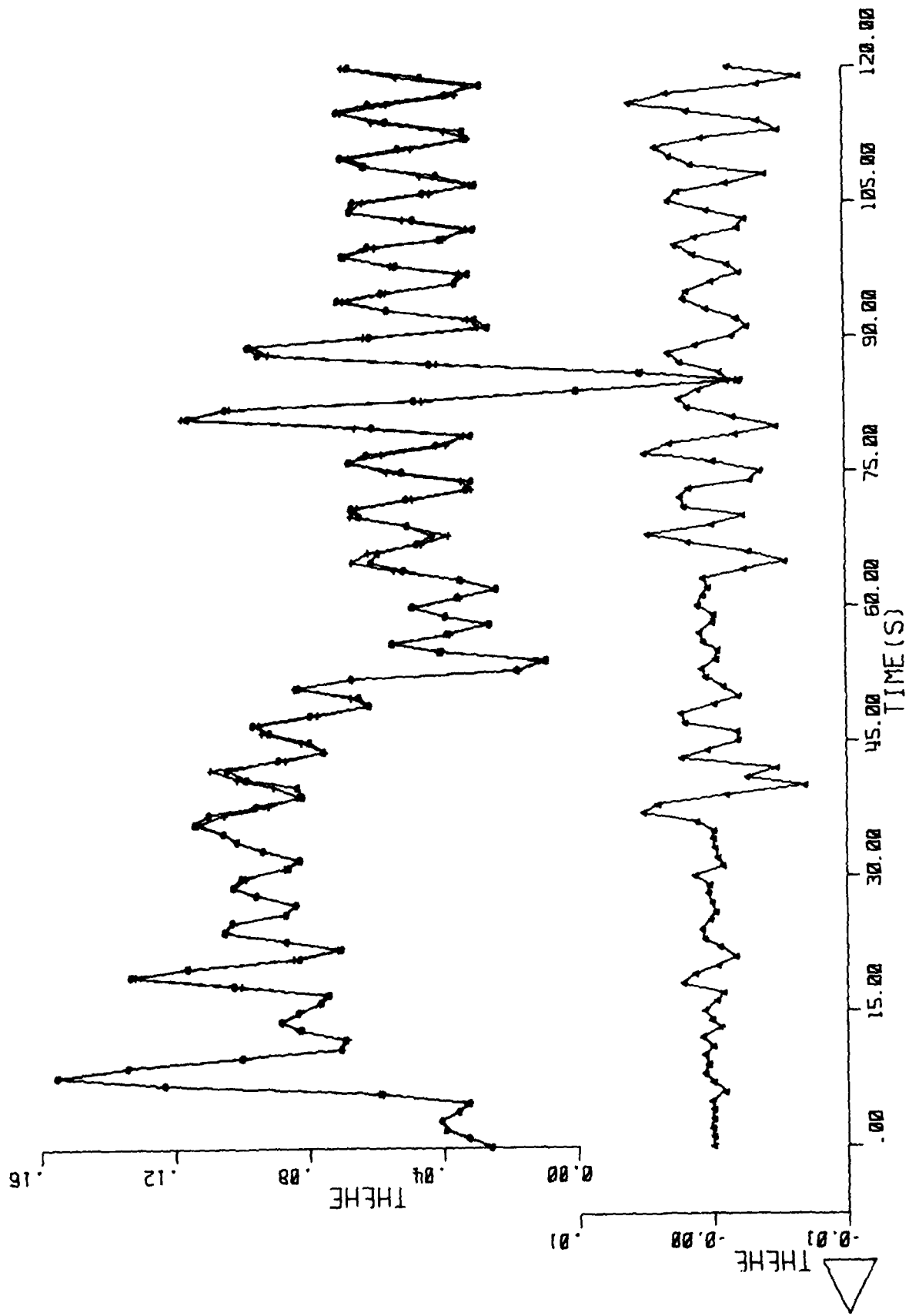

FIG. 4(d) PITCH ATTITUDE, RADIAN

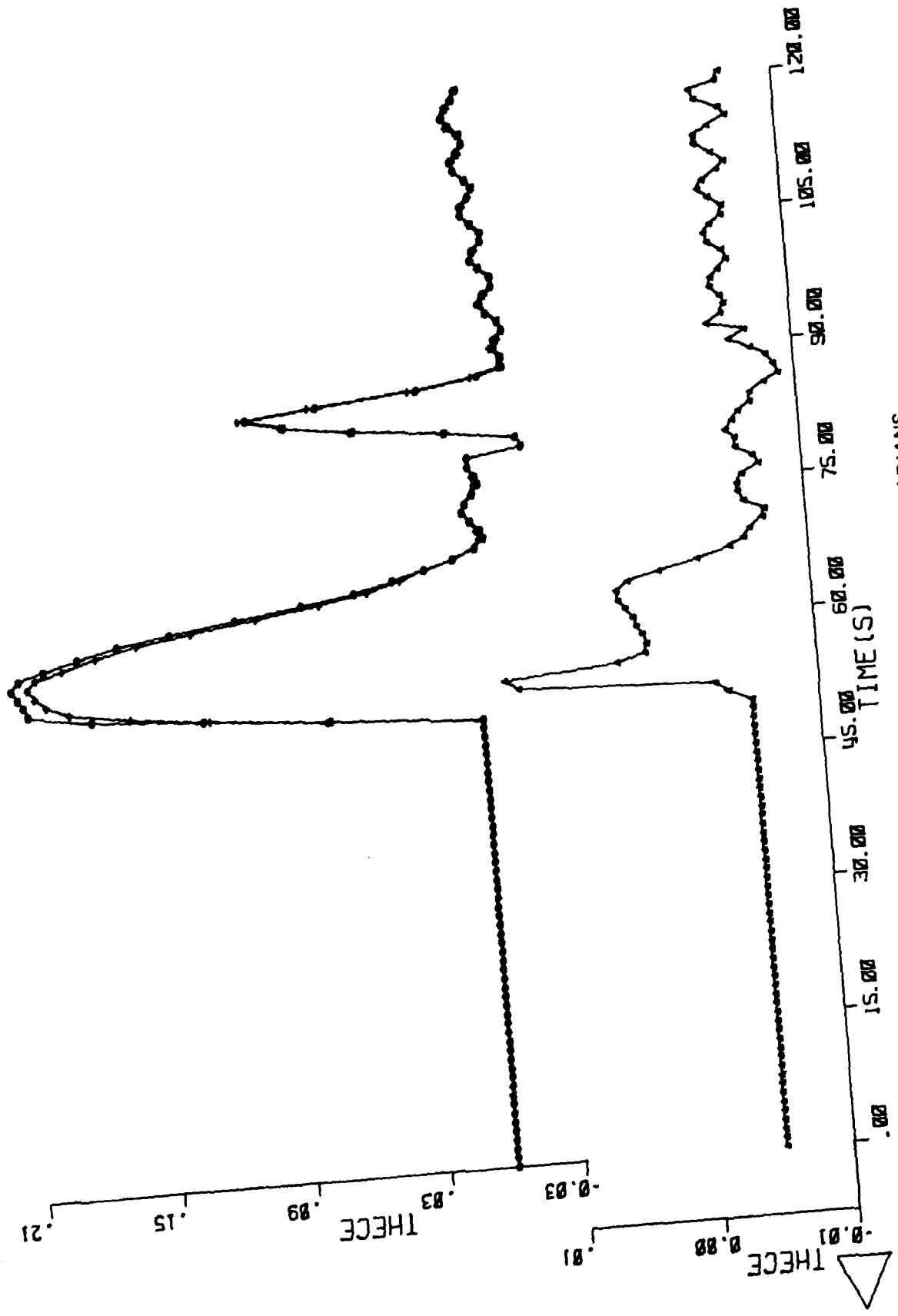

FIG. 4(e) CABLE ANGLE (PITCH) RADIAN

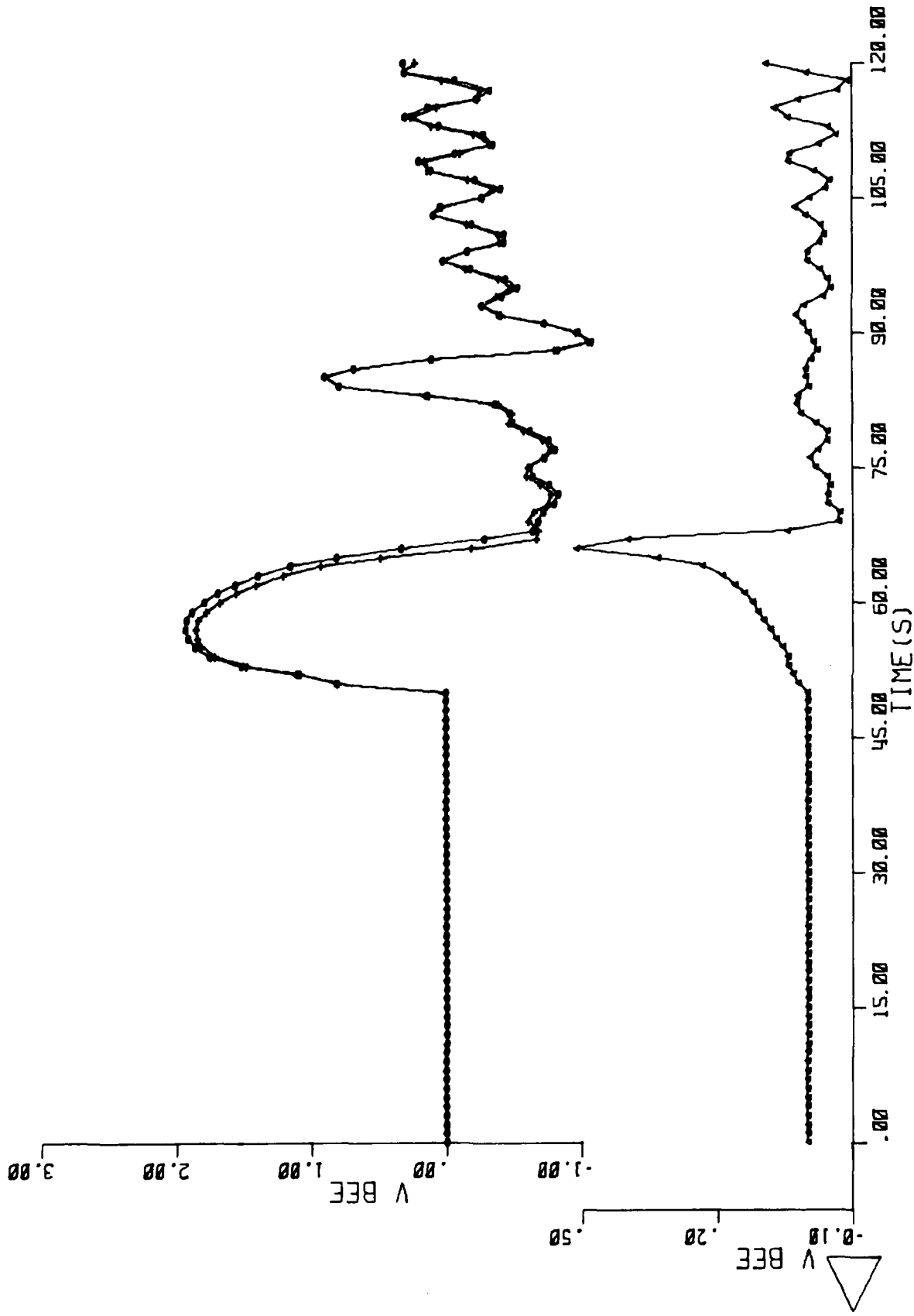

FIG. 4(f) BALL VELOCITY (LATERAL) FT/SEC

## APPENDIX I

### Control System Block Diagrams

- Fig. A1. Hover coupler—pitch channel
- Fig. A2. Hover coupler—roll channel
- Fig. A3. Hover coupler—altitude channel
- Fig. A4. Autopilot—pitch channel
- Fig. A5. Autopilot—roll channel
- Fig. A6. Autopilot—altitude channel
- Fig. A7. Autopilot—yaw channel
- Fig. A8. Flying controls—pitch channel
- Fig. A9. Flying controls—roll channel
- Fig. A10. Flying controls—altitude channel (hydraulics)
- Fig. A11. Collective stick model
- Fig. A12. Flying controls—yaw channel

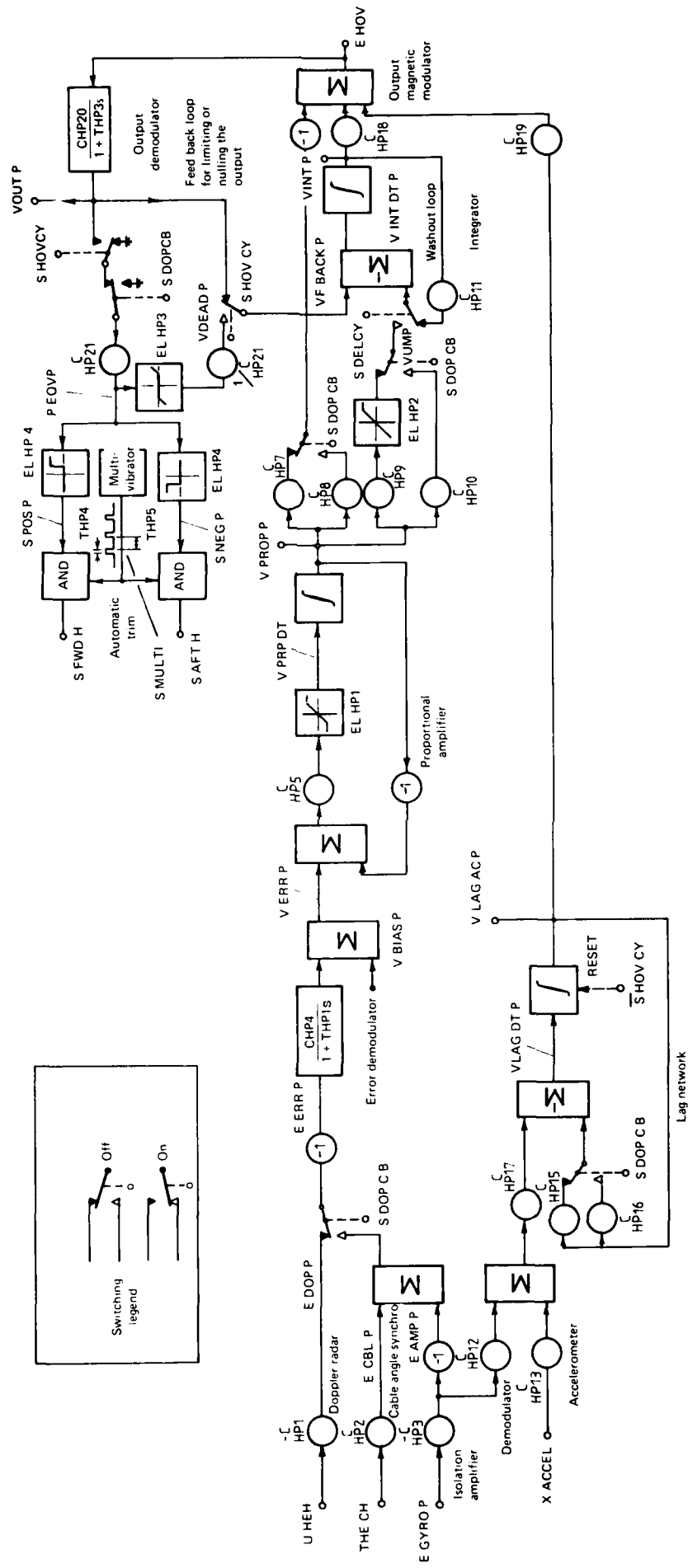

FIGURE A1. HOVER COUPLER - PITCH CHANNEL.

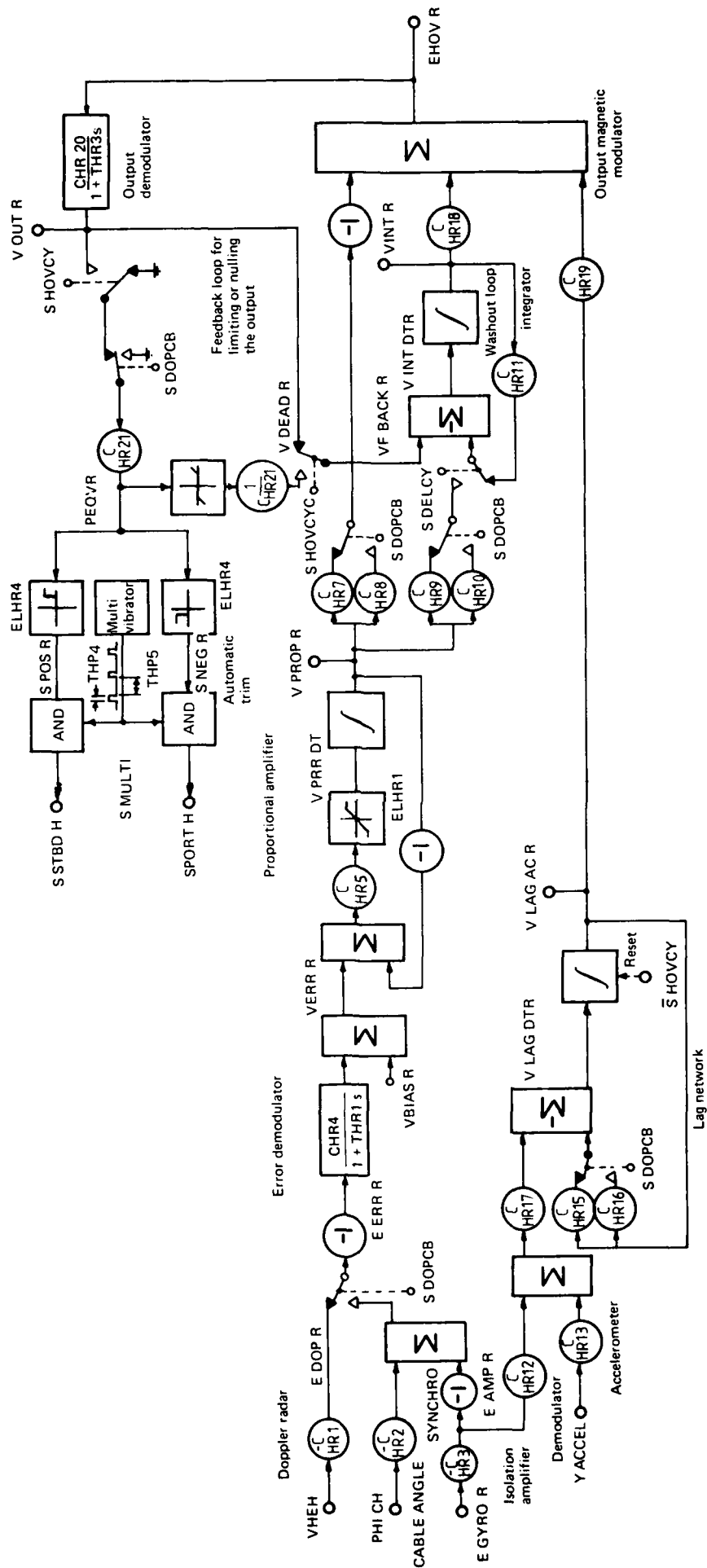

FIG. A2 HOVER COUPLER ROLL CHANNEL

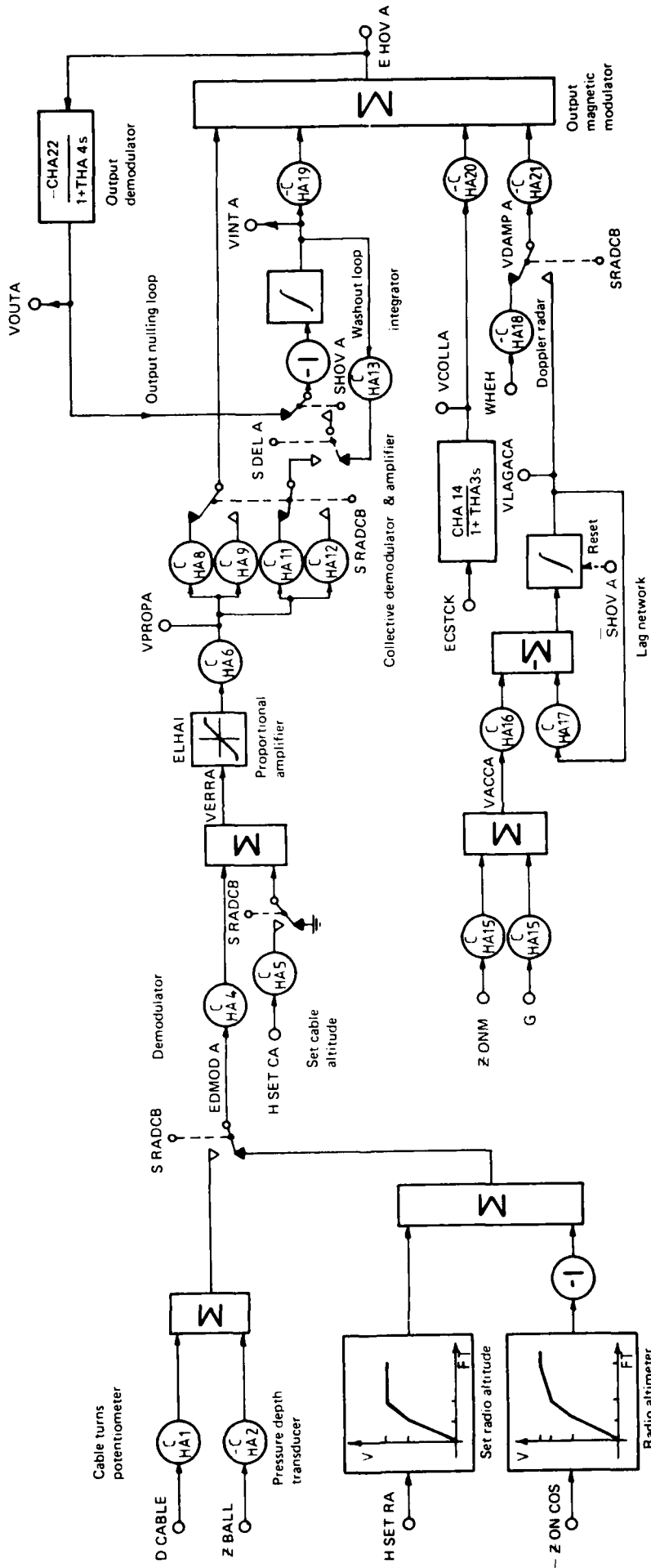

FIG. A3. HOVER COUPLER - ALTITUDE CHANNEL

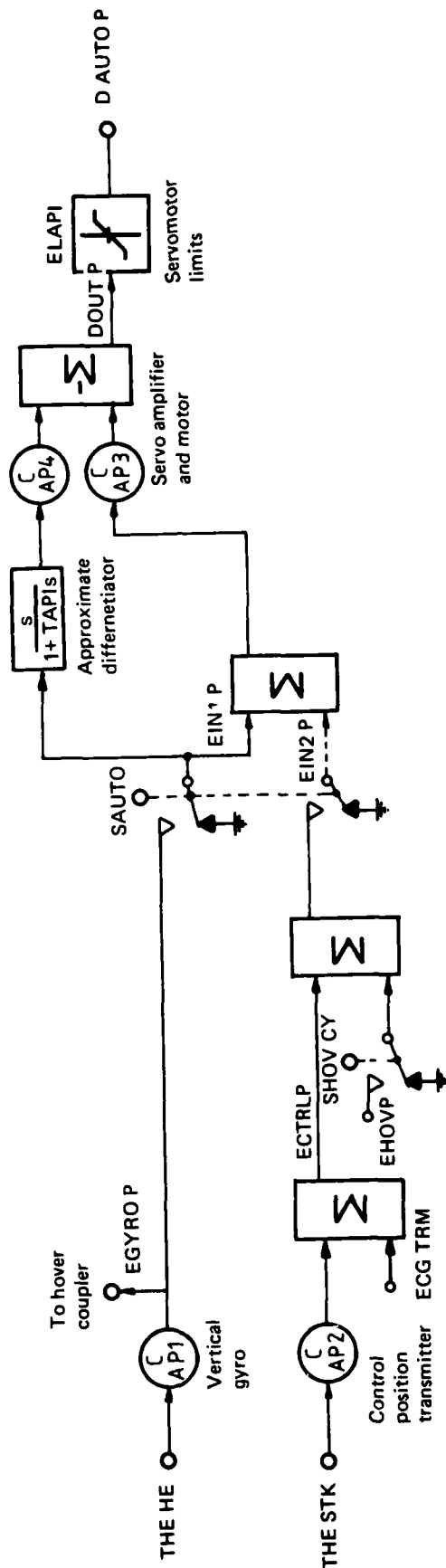

FIG. A4. AUTOPILOT - PITCH CHANNEL

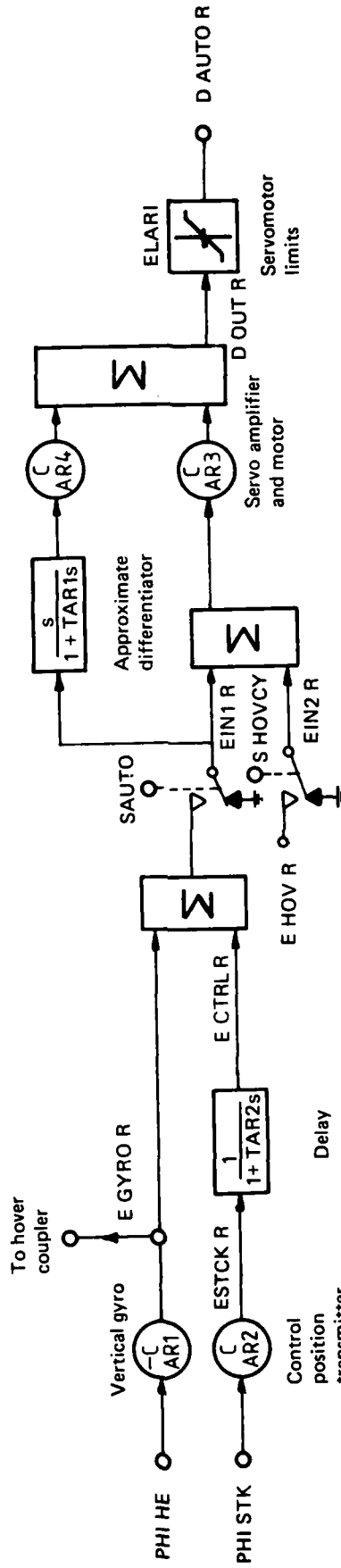

FIG. A5. AUTOPILOT - ROLL CHANNEL

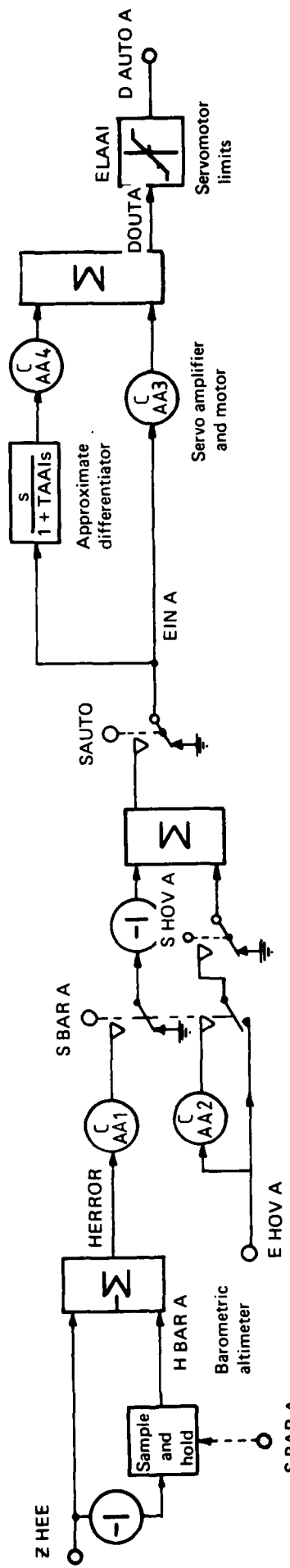

FIG. A6. AUTOPILOT--ALTITUDE CHANNEL

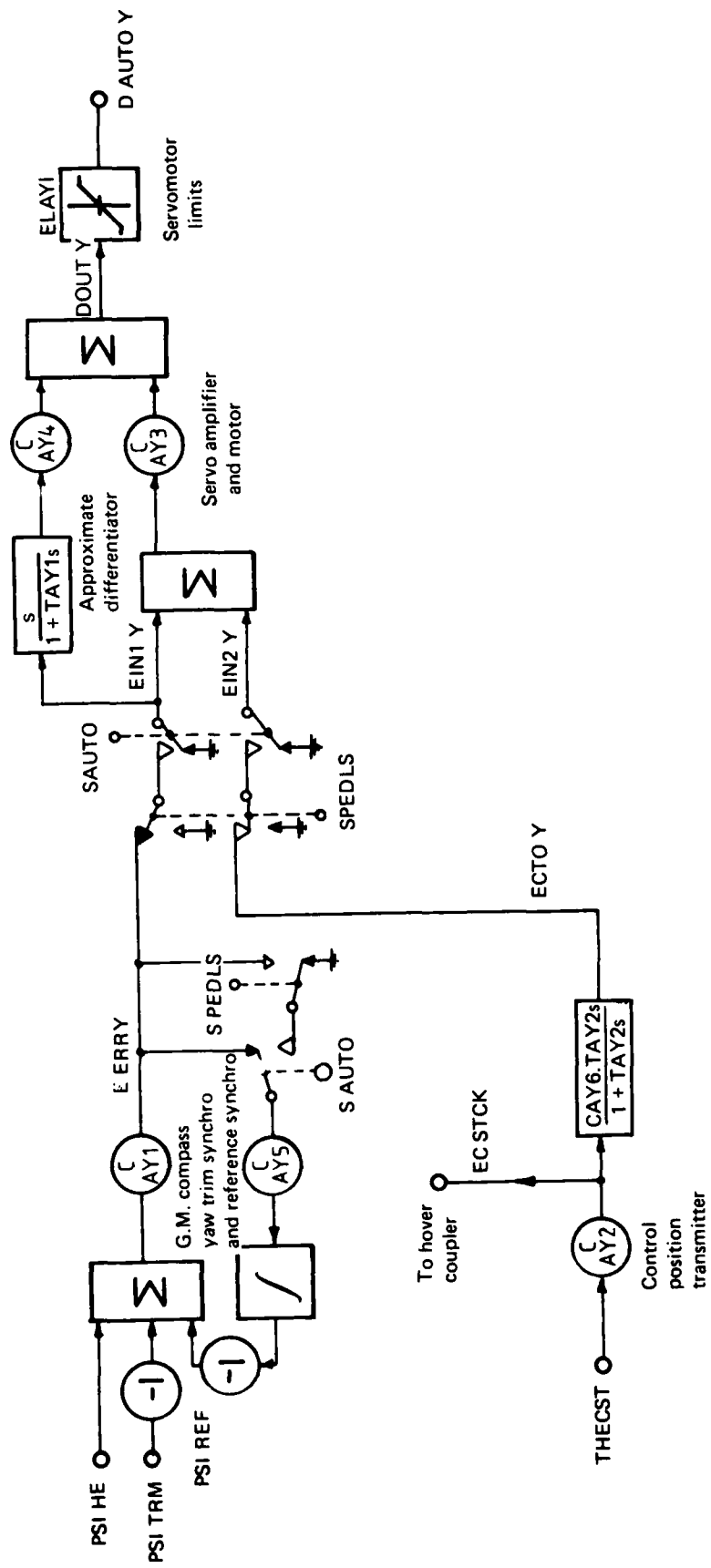

FIG. A7. AUTOPILOT-YAW CHANNEL





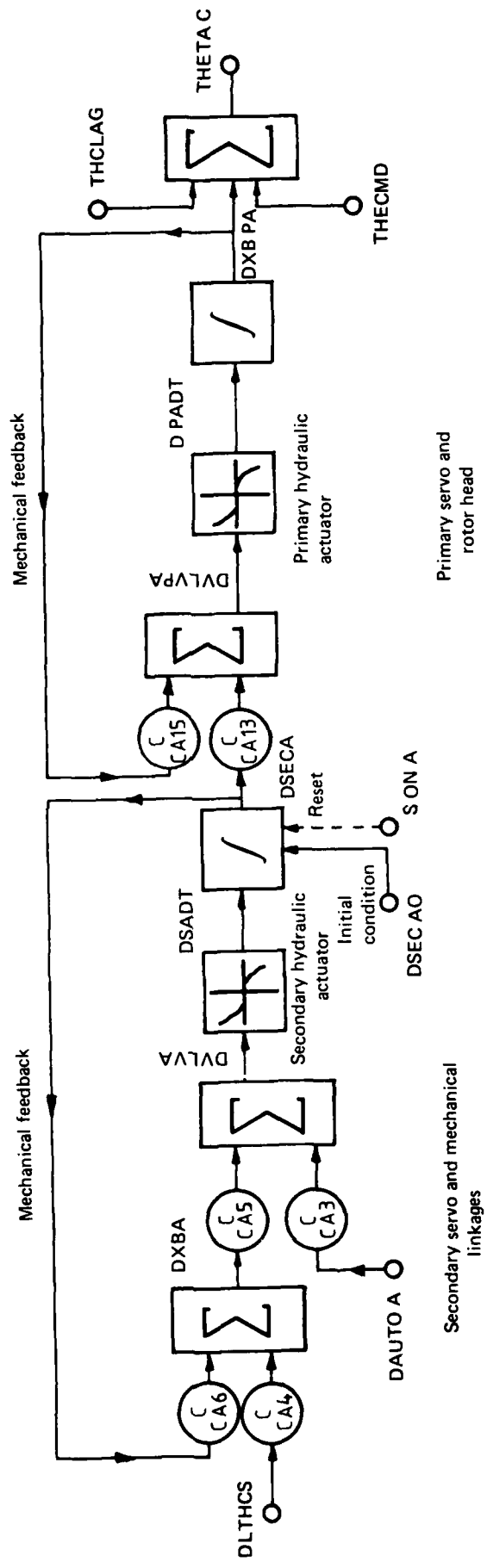

FIG. A10. FLYING CONTROLS - ALTITUDE CHANNEL HYDRAULICS



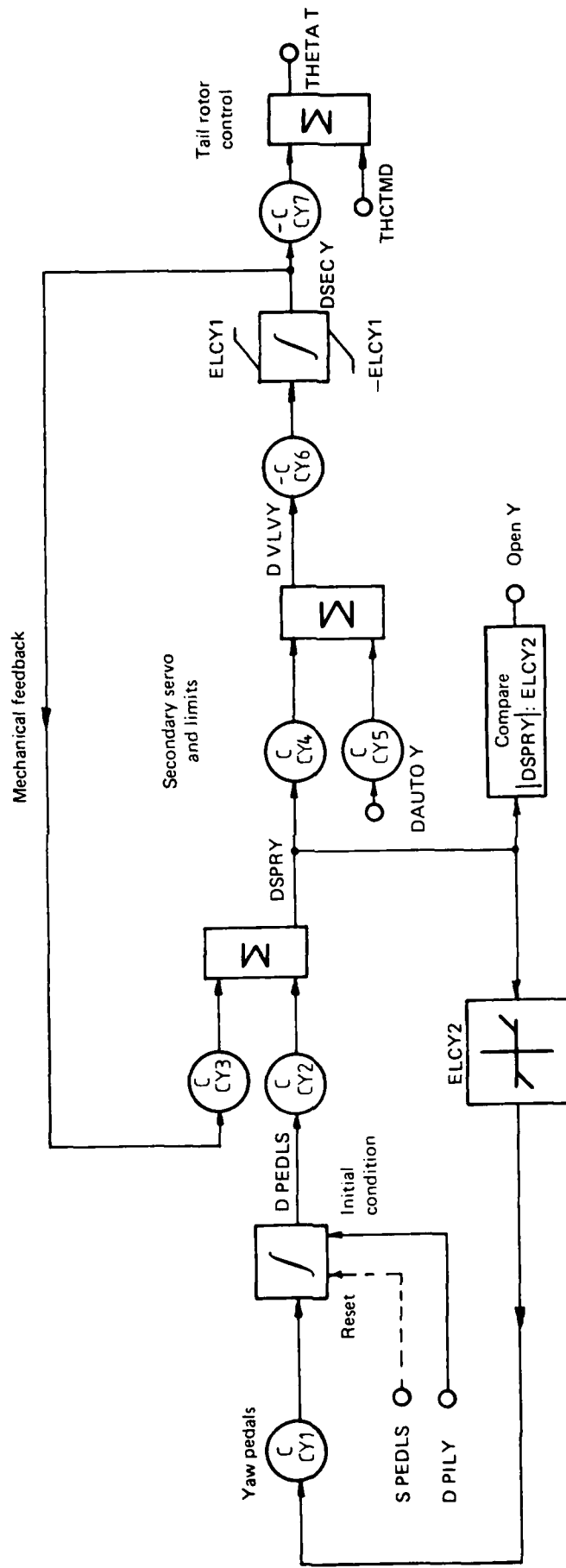

FIG. A12. FLYING CONTROLS - YAW CHANNEL

## DISTRIBUTION

### AUSTRALIA

#### Department of Defence

Copy No.

##### Central Office

Chief Defence Scientist	1
Deputy Chief Defence Scientist	2
Superintendent, Science and Technology Programs	3
Australian Defence Scientific and Technical Representative (U.K.)	4
Counsellor, Defence Science (U.S.A.)	5
Defence Library	6
Joint Intelligence Organisation	7
Assistant Secretary, D.I.S.B.	8-23

##### Aeronautical Research Laboratories

Chief Superintendent	24
Library	25
Superintendent, Aerodynamics Division	26
Divisional File, Aerodynamics Division	27
Authors: N. V. Williams	28-29
C. R. Guy	30-31
M. J. Williams	32-33
N. E. Gilbert	34-35
D. C. Collis	36-39
D. A. Secomb	40
D. E. Hatton	41

##### Materials Research Laboratories

Library	42
---------	----

##### Defence Research Centre, Salisbury

Library	43
---------	----

##### Central Studies Establishment

Information Centre	44
--------------------	----

##### Engineering Development Establishment

Library	45
---------	----

##### RAN Research Laboratory

Library	46
---------	----

##### Navy Office

Naval Scientific Adviser	47
Director, Naval Aircraft Engineering	48
Director, Naval Aviation Policy	49
AMAFTU, Nowra	50

##### Army Office

Army Scientific Adviser	51
U.S. Army Standardisation Group	52
Royal Military College	53

##### Air Force Office

Aircraft Research and Development Unit	54
Air Force Scientific Adviser	55
Engineering (CAFTS) Library	56
D.Air Eng.-AF	57
HQ Support Command (SENGSO)	58

<b>Department of Productivity</b>		
<b>Government Aircraft Factories</b>		
Manager/Library	59	
<b>Department of Transport</b>		
Secretary	60	
<b>Statutory, State Authorities and Industry</b>		
Commonwealth Aircraft Corporation, Manager	61	
Hawker de Havilland Pty Ltd, Librarian, Bankstown	62	
ICI Australia Ltd Library	63	
<b>Universities and Colleges</b>		
Sydney	Professor G. A. Bird	64
RMIT	Mr H. Millicer	65
<b>CANADA</b>		
NRC, National Aeronautical Establishment, Library	66	
<b>FRANCE</b>		
AGARD, Library	67	
Onera, Library	68	
Service de Documentation, Technique de l'Aeronautique	69	
<b>INDIA</b>		
National Aeronautical Laboratory, Director	70	
Hindustan Aeronautics Ltd, Library	71	
<b>NETHERLANDS</b>		
National Aerospace Laboratory (NLR) Library	72	
<b>UNITED KINGDOM</b>		
Aeronautical Research Council, Secretary	73	
Royal Aircraft Establishment, Library—Farnborough	74	
Royal Aircraft Establishment, Library—Bedford	75	
Westland Helicopters Ltd	76	
<b>UNITED STATES OF AMERICA</b>		
NASA Scientific and Technical Information Facility	77	
American Institute of Aeronautics and Astronautics	78	
Lucas Industries North America Inc. (Mr. T. W. Yates)	79	
Spares	80-94	