

AD-A086 586

COLD REGIONS RESEARCH AND ENGINEERING LAB HANOVER NH  
DEVELOPMENT OF A HIGH-SPEED ROTARY SNOWPLOW (HTR-700), (U)  
MAR 79 T SASAKI, G HORIKAWA  
CRREL-TRANS-709

F/8 13/6

UNCLASSIFIED

NL

F 48 1

50

Diagram



END  
DATE  
FILMED  
8-90  
DTIC

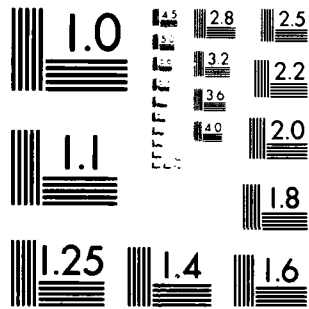

MICROCOPY RESOLUTION TEST CHART  
NATIONAL BUREAU OF STANDARDS-1963-A

ADA 086586

Draft Translation 709

March 1979

②

# DEVELOPMENT OF A HIGH-SPEED ROTARY SNOWPLOW (HTR-700)

T. Sasaki and G. Horikawa

DTIC  
ELECTE  
S JUL 10 1980 D  
B

DDC FILE COPY



UNITED STATES ARMY  
CORPS OF ENGINEERS  
COLD REGIONS RESEARCH AND ENGINEERING LABORATORY  
HANOVER, NEW HAMPSHIRE, U.S.A.



Approved for public release; Distribution Unlimited

30 0 30 11

NOTICE

The contents of this publication have been translated as presented in the original text. No attempt has been made to verify the accuracy of any statement contained herein. This translation is published without copy editing or graphics preparation in order to expedite the dissemination of information. Requests for additional copies of this document should be addressed to the Defense Documentation Center, Cameron Station, Alexandria, Virginia 22314.

UNCLASSIFIED

SECURITY CLASSIFICATION OF THIS PAGE (When Data Entered)

REPORT DOCUMENTATION PAGE		READ INSTRUCTIONS BEFORE COMPLETING FORM
1. REPORT NUMBER Draft Translation 709	2. GOVT ACCESSION NO. AD-86586	3. RECIPIENT'S CATALOG NUMBER TRANS-709
4. TITLE (and Subtitle) DEVELOPMENT OF A HIGH-SPEED ROTARY SNOWPLOW (HTR-700)	5. TYPE OF REPORT & PERIOD COVERED Translation	
	6. PERFORMING ORG. REPORT NUMBER	
7. AUTHOR(s) Tetsuya Sasaki and Go Horikawa	8. CONTRACT OR GRANT NUMBER(s)	
9. PERFORMING ORGANIZATION NAME AND ADDRESS	10. PROGRAM ELEMENT, PROJECT, TASK AREA & WORK UNIT NUMBERS	
11. CONTROLLING OFFICE NAME AND ADDRESS U.S. Army Cold Regions Research and Engineering Laboratory Hanover, New Hampshire 03755	12. REPORT DATE 11 March 1979	
	13. NUMBER OF PAGES 29	
14. MONITORING AGENCY NAME & ADDRESS (if different from Controlling Office)	15. SECURITY CLASS. (of this report) Unclassified	
	15a. DECLASSIFICATION/DOWNGRADING SCHEDULE	
16. DISTRIBUTION STATEMENT (of this Report) Approved for public release; distribution unlimited.		
17. DISTRIBUTION STATEMENT (of the abstract entered in Block 20, if different from Report)		
18. SUPPLEMENTARY NOTES Translated by Tech Tran Inc., Glen Burnie, Maryland.		
19. KEY WORDS (Continue on reverse side if necessary and identify by block number) Snow Snowplows Snow removal		
20. ABSTRACT (Continue on reverse side if necessary and identify by block number) The development of a rotary snowplow designed to remove 3000 tons/hour of snow at a speed of 20 km/hr is described. The four-wheel-drive vehicle was designed for use in areas of Hokkaido where snow accumulation and drifting are a major problem. It is powered by a 700-hp diesel engine and weighs about 22,000 kg. The snow removal equipment consists of a two-stage blower with cone ribbon screw type auger. The device has been tested in heavy snow conditions with snowlides and drifting, with excellent results and only minor mechanical problems.		

## DEVELOPMENT OF A HIGH-SPEED ROTARY SNOWPLOW (HTR-700)\*

Tetsuya Sasaki and Go Horikawa

### Introduction

Various snow removal equipment is used in the northern areas of our country for facilitating traffic during the winter season, and these are plow-type snow removal vehicles for high speed clearing. However, these are not sufficient for snow removal under all circumstances.

For example, in the areas where there is heavy snow and strong winds, the factor of snow drifting makes it harder to remove the snow and causes great tie-ups in traffic patterns.

The heavier traffic also makes it necessary to curtail snow removal periods, and in the above-mentioned windy, snowy areas there many cities are employing rotary snowplows.

However, presently used rotary snow removal equipment can only remove snow at a double width at low speed, even when only a little snow is removed by a sidewing or snow is removed by a plow-type snow remover.

Many people have called for better equipment to solve the problem of combining a plow-type snow remover and double width snow removal. We have been led to develop this new rotary snowplow.

Research began on a high-speed rotary snowplow in 1966 at the Northern Architectural Division in the Sendai Technological Laboratories. The planning stages for the one-stage SR-303 rotary snowplow were finished in 1971, but we have developed a new two-stage type rotary snowplow, taking into consideration the unique conditions of Hokkaido.

### 1. Basic Conditions

The following points emerged as a result of the investigations and deliberations of a committee consisting of the home office, the construction section and the architectural divisions to determine the main specifications.

- (1) Location for use -- main arteries of the areas where winds are high and there is much snow.
- (2) Construction level -- to handle drifting and double-width removal, mainly for new snow.
- (3) Procedure -- mainly to remove snow at a high speed, combining the truck and plow snow removal vehicles.
- (4) Snow removal speed -- 20 km/hr (to throw the snow a distance of 15 m).
- (5) Normal speed -- over 40 km/hr (on a 6% grade).

\*From Engineering Report, vol. 6, no. 46, p. 38-50.

- (6) Steering axle -- front axle.
- (7) Quantity of snow removed -- 3000 tons/hr.
- (8) Snow removal equipment type -- two-stage vehicle.
- (9) Auger, blower diameter = 1.5 m less than the corresponding dimension of the vehicle.
- (10) Snow removal equipment width -- 2.75 m at 40 km/hr with normal maintenance standards.
- (11) Parts -- as much as possible those used were automobile parts.

The above eleven items are considered the important ones for the amount of snow removed and the type of snow removal equipment. They are explained in more detail below.



Figure 1. Double Width Operation.

First we shall discuss the amount of snow to be removed. We measured the amount of snow which fell for four months (from December of 1967 to March of the following year) at the snow removal station on the Nakayama Pass highway because we had decided to study the important traffic-arteries of the area where there is heavy wind and snow. Table 1 below shows the amount of fallen snow in increments of 5 cm, convenient for measurements.

According to these figures, we could cope with 90% of the accumulated snow during one year, and this amount turned out to be 30 cm (approximately one foot). This was thought to be almost no problem on 98.4% of the days of the year.

If we calculate the amount of snow to be removed, the width of the amount of snow to be effectively removed on one side is 4.5 m, taking into consideration snow drifts on the width of the pavement because this is a C-1 grade highway with a pavement width of 7.5 m. At a snow removal speed of 20 km/hr, the amount of snow removed every hour is  $0.3 \times 4.5 \times 20,000 = 27,000 \text{ m}^3/\text{hr}$ .

TABLE 1.

Amount of Snowfall In One Day	December		January		February		March		No. of Days	No. of Days (%)	Accumulated Snow (cm)	Accumulated Snow (%)
	a	b	a	b	a	b	a	b				
0 cm	7	6	3	6	6	7	5	11	51	42.1	0	0
Less than 5 cm	2	3	1	1	3	2	1	2	15	12.4	75	7.4
Less than 10 cm	5	2	5	2	3	1	3	0	21	17.4	210	21.6
Less than 15 cm	0	3	3	2	0	1	2	2	13	10.7	135	13.1
Less than 20 cm	1	2	1	0	2	1	3	0	10	8.3	200	19.6
Less than 25 cm	0	0	0	1	0	1	1	0	3	2.5	75	7.4
Less than 30 cm	0	0	2	2	1	1	0	0	6	5.0	180	17.6
Less than 35 cm	0	0	0	0	0	0	0	0	0	0	0	0
Less than 40 cm	0	0	0	1	0	0	0	0	1	0.8	40	3.9
Less than 45 cm	0	0	0	1	0	0	0	0	1	0.8	45	4.4
Total									121		1,020	

a = 1st half  
b = 2nd half

A table of the amount of snowfall at the Nakayama Pass snow removal station during 1967.

However, while it is snowing, ordinary vehicles pass through and pack down the snow. Therefore the snow from the center of the road is pushed to the sides of the highway by plow-type snow removal equipment. Therefore the density of the snow rises and the amount increases. The decrease ratio in the measured area was as follows: 0.08 new snow became 0.16 to 0.21 after being pushed by a plow, and 0.20 to 0.30 after being pushed by a bulldozer.

We decided on 0.25, taking into consideration the above-mentioned conditions.

The specific gravity of new snow is 0.05 to 0.15, as mentioned in a report of the Hokkaido University's Low Temperature Scientific Laboratory. Immediately after falling it is 0.05 to 0.10, and we decided on 0.1 for our figure for new snow immediately after falling. From the above, the amount of snow that a rotary snowplow must handle is 10,800 m<sup>3</sup>/hr because of a 1/2.5 density change. The snow removal rate was computed at 2700 tons/hr, but to give us a little leeway, we set the capability of the snow removal equipment at 3000 tons/hr.

The following is a description of the type of equipment chosen for snow removal. In general it is divided into one-stage and two-stage equipment and can be described mechanically as follows.

- One-stage type
  - Blower type
  - Cutter type
- Two-stage type
  - Ribbon screw type
  - Worm conveyor type
  - Rake-tooth type

ACCESSION for	
NTIS	White Section <input checked="" type="checkbox"/>
DDC	Buff Section <input type="checkbox"/>
UNANNOUNCED <input type="checkbox"/>	
JUSTIFICATION _____	
BY _____	
DISTRIBUTION/AVAILABILITY CODES	
Dist.	AVAIL. and/or SPECIAL
A	

The above types each have their unique applications, and the following intensive applications can be seen from the test data collected for high-speed machinery from performance tests, research and long-range experiments.

(1) The cutter, worm conveyor and rake-tooth types are unsuitable for transportation and carrying drums.

(2) The blower and ribbon screw types have been judged suitable by the Architectural Department and our test results.

Accordingly we decided to use the one-stage type blower and the two-stage type ribbon screw types hereafter. We have decided on this type of snow removal equipment suitable for the roads, based on comparative tests taking into consideration Hokkaido's unique situation.

#### A Comparison of the One-Stage and Two-Stage Types

(1) The one stage type is related to a blower and pre-cutter revolution method for throwing snow and is very dangerous when tossing snow to the center of the road in the cases where snow is mixed with ice and other foreign matter (rocks, asphalt or broken tire chains). (Refer to Figure 1.)

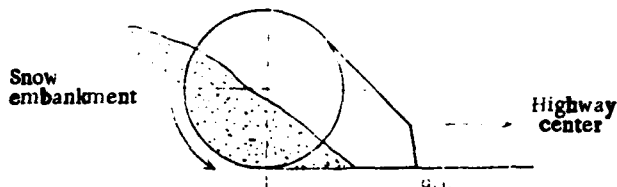

Figure 1.

(2) The one-stage type is very difficult to repair in case of accident because the blower blades are set at a special angle.

(3) The one-stage type was designed for a snow density of  $\pm 0.25$  and therefore can scatter excess snow from the precutter or blower. Besides that it agitates in the same direction as the blower, and therefore it is predicted that it will scatter a lot of snow and provide obstacles for driving. (Result of our laboratory's comparative test.)

(4) The one-stage type has a blower which only compresses the snow, and the density of the snow which is tossed from the stack is low. Therefore the same problems arise as in paragraph (3) where the snow can be easily scattered because of the wind. (Also a result of our laboratory's comparative test.)

(5) Compared to the one-stage type, the two-stage type is much better for highway snow removal. (It is also capable of scraping off a small amount of glare ice.)

(6) The results of the comparative test with the SR-250 type, which were done in the northern country, can be interpreted as saying that there is no appreciable difference between the two types according to their report. (September 1967 "The Design Specifications of a High-Speed Rotary Snowplow".)

(7) The results of a comparative test performed in this laboratory (technical bulletin, Vol. 5, No. 43 -- Performance Tests on a Large Rotary Snowplow) were also judged as indicating that there was almost the same level of performance and snow removal speed.

(8) The SR-300 type was designed as a one-stage vehicle, especially for double width. Therefore it is efficient because it is relatively wide. (Refer to Figure 1.)

(9) The one-stage type is simple in design and therefore easy to build.

(10) The specifications of the rotary snowplow were made for easy handling of snow drifts, new snow and double width snow removal in Hokkaido. Because there are many factors affecting the performance of the rotary snowplow, for example road conditions with heavy snow accumulation or high density, the type of system which cannot send a fixed amount of snow inside the blower, unlike the one-stage type, has the large percentage of chute closing (depending on the actual accumulation).

From the above information the high-speed snow removal equipment suitable for the type of snow removal method in Hokkaido (Figure 2) has been determined to be the two-stage type.

## 2. The Single-Engine and Oil Pressure Motor Operation System

The purpose in using the single-engine system is explained for the following reasons below.

- (1) The overall length of the vehicle can be shortened.
- (2) Output efficiency is increased.
- (3) The engine control system can be simplified.
- (4) Maintenance is easy because the equipment is arranged logically.

As concerns the oil pressure motor operation system:

(1) It is a characteristic of Hokkaido for the snow removal conditions to change quickly, and therefore load changes are intense. Serious consideration was given to maintenance because of the rise and fall in the snow removal speed depending on the load.

(2) Maintenance is easy because it is unnecessary to change speeds while running.

(3) It was anticipated that the normal operation would be at high horsepower, but it was possible to refer it and use the present type because the most widely traveled roads are narrow.

The above are the reasons why we decided to use the single-engine system and the oil pressure motor operating system.

### 3. Power Mathematics

#### (1) Auger

##### a. The Transport Capabilities of the Auger

Up till now the relationship between the bore length ( $t$ ) and the auger cog width at low speeds (under 10 km/hr) was considered experientially in terms of  $t \geq t_0$ .

The relationship between  $t$  and  $t_0$  at high speeds had not been experienced before, and theoretically was visualized as follows.

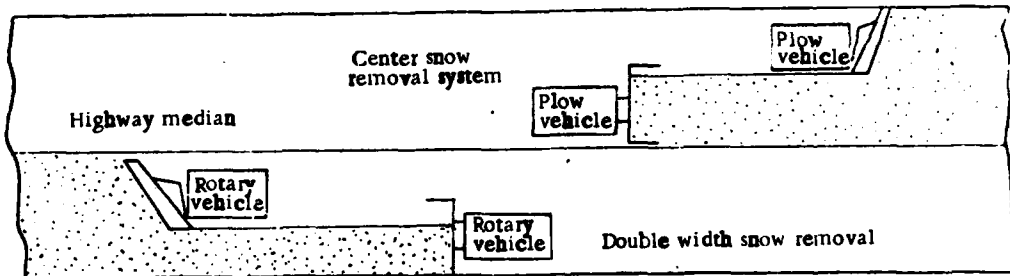

Figure 2.

#### (A). Transport Cross-Section

The machinery for moving the auger was theoretically based on a worm conveyor.

The sectional capacity relative to movement is shown in Figure 3 as arc  $PBC \times t$ . (However,  $PB \times t$  can change the forward speed depending on the operational speed.)

$$S_1 = \widehat{PB} \times t \quad S_2 = \widehat{BC} \times t$$

$$\cos \theta = \frac{D_1 - 2h}{D_1} \dots \dots \dots (1)$$

$$S_1 = \frac{\pi}{4} (D_1^2 - D_2^2) \cdot \frac{\theta}{360}$$

$$S_2 = \frac{\pi}{4} (D_1^2 - D_2^2) \cdot \frac{1}{4} \quad (2)$$

$$S = S_1 + S_2$$

$$S = \frac{\pi}{4} (D_1^2 - D_2^2) \cdot \left( \frac{\theta}{360} + \frac{1}{4} \right) \dots \dots \dots$$



$$V_o = V_c + V_s \quad (3)$$

$V_o$  = auger speed (m/sec)

$V_c$  = snow removal speed -- 30 km/hr

$V_s$  = reciprocal speed -- 5 m/sec

$N_o$  = auger number of revolutions (rpm).

$$N_o = \frac{60 \cdot V_o}{\pi D_o} \quad (4)$$

(3) By the formula

$$V_o = \frac{30,000}{3,600} + 5 = 13.3 \text{ m/s}$$

(4) The number of revolutions of the auger by the formula becomes

$$N_o = \frac{60 \times 13.3}{3.14 \times 1.5} = 177 \text{ r.p.m.}$$

(C) Forward Speed

$$V_y = \frac{P \cdot N_o}{60} \quad (5)$$

$V_y$  = forward speed (m/sec)

P = auger pitch -- 2.4 m

$$V_y = \frac{2.4 \times 177}{60} = 6.8 \text{ m/s}$$

The auger transport capacity is

$$Q_o = S \cdot V_y \cdot 3,600 \times 2 \cdot \phi_o \quad (6)$$

$Q_o$  = auger transport capacity ( $\text{m}^3/\text{hr}$ )

$\phi_o$  = transport rate -- 0.8

$$Q_o = 0.305 \times 6.8 \times 3,600 \times 2 \times 0.8$$

$$= 12,000 \text{ m}^3/\text{h}$$

THIS PAGE IS BEST QUALITY PRACTICABLE  
FROM COPY FURNISHED TO DDC  
-8-

$$Q_{ow} = Q_o \cdot \rho$$

$Q_{ow}$  = quantity of snow removed (tons/hr)

$\rho$  = snow specific gravity -- 0.25

$$Q_{ow} = 12,000 \times 0.25 = 3000 \text{ t/hr}$$

b. Auger Power

At present there are no data concerning the auger power at high speeds, and therefore we have used the experiments at low speeds.

This system was developed by Mr. Ei Yamazaki of the No. 1 Technical Section of the Mitsubishi Heavy Industry Tokyo Construction site.

There is also the Cicardo method, but the number of areas where it has been used is extremely small, and therefore we did not use it.

$$P_o = \left\{ 0.0133 + 0.042 \frac{\mu}{P_1} \left( D_1 - 40 \frac{V_c}{N_o} \right) \right. \\ \left. \cos^2 \delta + 0.0133 \mu \sin \delta \cos \delta \right\} \\ K_1 f Q_o \dots\dots\dots (7)$$

$P_o$  = auger horsepower (HP)

$\mu$  = friction resistance -- 0.1

$K_1$  = systems number of f, determined from the auger shape

$f$  = snow compression strength = 2500 kg/m<sup>2</sup>

$$\tan \delta = \frac{V_c \cdot 60}{P_1 \cdot N_o} \dots\dots\dots (8)$$

$$\tan \delta = \frac{5.55 \times 60}{2.4 \times 170} = 0.816 \dots\dots\dots 39^\circ 12'$$

$$P_o = \left\{ 0.0133 + 0.042 \frac{0.1}{2.4} \left( 1.5 - 40 \frac{5.55}{170} \right) \right. \\ \left. 0.774^2 + 0.0133 \times 0.1 \times 0.632 \times 0.774 \right\}$$

$$0.6 \times 2.500 \times \frac{12,000}{3,600} = 70.7 \text{ HP}$$

THIS PAGE IS UNCLASSIFIED  
DATE 10/15/01 BY 60322 UCBAW

(2) The Blower

a. Rotation Speed of the Blower

The rotation speed of the blower is determined by the distance of the snow thrown, and is projected at the high speed snow removal rate (20 km/hr) at 15 m and at the low speed rate of 30 m.

The formula for the snow throwing distance is that of Mr. Sige Shimada and computes the number of blower revolutions from the following formula, taking into consideration the quality of the snow and available experimental data.

$$z = \frac{V_b^2}{g} \cdot \eta_L \dots (\text{投雪角度 } 45^\circ \text{ 以下}) \dots \quad (8)$$

$$V_b = \frac{\pi D_b N_b}{60} \dots \quad (9)$$

- $z$  = distance of thrown snow (m)
- $V_b$  = blower rotation speed (m/sec)
- $\eta_L$  = thrown snow efficiency -- 0.7
- $N_b$  = number of blower revolutions (rpm)
- $D_b$  = blower outer diameter -- 1.5 m
- $g$  = acceleration of gravity

From formulas (8) and (9) we find

$$N_b = \frac{60}{\pi D_b} \cdot \sqrt{\frac{gz}{\eta_L}} \dots \quad (10)$$

If we set the distance snow is thrown in the first case at 15 m and in the second case at 30 m, we find:

In the case of 15 m we have

$$N_b = \frac{60}{3.14 \times 1.5} \cdot \sqrt{\frac{9.8 \times 15}{0.7}} \approx 190 \text{ r. p. m}$$

In the case of 30 m we have

$$N_b = \frac{60}{3.14 \times 1.5} \cdot \sqrt{\frac{9.8 \times 30}{0.7}} \approx 265 \text{ r. p. m}$$

THIS PAGE IS BEST QUALITY PRACTICABLE  
FROM COPY FURNISHED TO DDC

b. Blower Depth

The blower depth is computed as follows from the quantity of snow removed, the blower diameter and the number of revolutions.

$$Q_b = A_b \cdot t_b - A_i \dots \dots \dots (11)$$

$$Q_b = N_b \cdot \frac{Q_b \cdot \epsilon}{60 \cdot \xi} \dots \dots \dots (12)$$

$Q_b$  = blower capacity ( $m^3$ )

$A_b$  = blower cross-section ( $m^2$ )

$t_b$  = blower (m)

$A_i$  = blower blade and spinner volume =  $0.03 m^3$

$\epsilon$  = density change rate -- 1.2

$\xi$  = blower volumetric efficiency -- 0.8

From formulas (11) and (12) we find

$$t_b = \frac{Q_b \cdot \epsilon}{A_b \cdot N_b \cdot 60 \cdot \xi} + \frac{A_i}{A_b} \dots \dots \dots (13)$$

In order to obtain the blower depth, we set the number of revolutions at 190 rpm and the thrown snow distance 15 m.

$$t_b = \frac{12,000 \times \frac{1}{1.2}}{4 \times 1.5^2 \times 190 \times 0.8 \times 60} + \frac{0.03}{\frac{3.14}{4} \times 1.5^2} = 0.65m$$

c. Blower Power

The calculation of the blower power is done by the formula of Mr. Ei Yamazaki, which is in general use.

$$P_b = (0.00068K_1 + 0.002 \mu K_2) \rho \cdot Q_b \cdot V_b^3 \dots \dots \dots (14)$$

$P_b$  = blower horsepower (HP)

$\rho$  = snow density --  $250 kg/m^3$

THIS REPORT IS OF QUALITY PRACTICABLE  
 FOR USE BY THE GENERAL PUBLIC

$K_2 = \text{coefficient} \text{ -- } 1$

$K_3 = \text{coefficient} \text{ -- } 1$

$Q_{by} = \text{m}^2/\text{sec}$

$$P_b = (0.00068 \times 1 + 0.002 \times 0.1 \times 1) \times 250 \\ \times \frac{12.000}{3.600} \times \left( \frac{3.14 \times 1.5 \times 190}{60} \right)^2 = 163.1 \text{HP}$$

THIS PAGE IS BEST QUALITY PRACTICABLE FROM COPY FURNISHED TO DDG

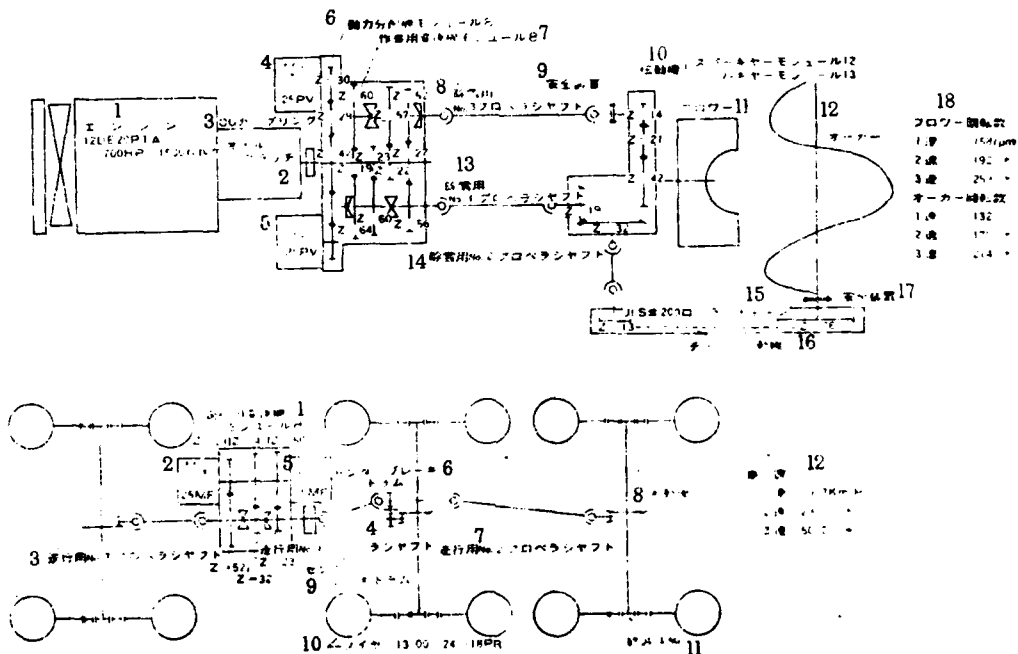

Figure 4. Diagrams of Transmission.

Key: Top diagram: 1, engine; 2, oil clutch; 3, CG coupling; 4, oil pump; 5, oil pump; 6, power distributor module 8; 7, operational gearbox module 8; 8, No. 3 propeller shaft for snow removal; 9, safety equipment; 10, transmission - overdrive module 12, bevel gear module 13; 11, blower; 12, auger; 13, No. 1 propeller shaft for snow removal; 14, No. 2 propeller shaft for snow removal; 15, JIS No. 200 roller chain; 16, chain drive; 17, safety equipment; 18, blower -- number of revolutions: 1st gear - 158 rpm, 2nd gear - 192 rpm, 3rd gear - 259 rpm, auger rpm, 1st gear - 132 rpm, 2nd gear - 170 rpm, 3rd gear - 214 rpm; Bottom diagram: 1, drive gearbox module 8; 2, oil motor; 3, No. 3 propeller shaft for running; 4, No. 1 propeller shaft for running; 5, motor; 6, center brake drum; 7, No. 2 propeller shaft for running; 8, differential; 9, center brake drum; 10, tire; 11, final moderator; 12, vehicle gears: 1st gear - 9.3 km/hr, 2nd gear - 29.0 km/hr, 3rd gear - 50.0 km/hr.

(3) Operating Power

The operating power is obtained from the following formula

$$P_c = \frac{V}{75 \times 3.6} (R_1 + R_2 + R_3) \dots \dots \dots (15)$$

$P_c$  = operating horsepower (HP)

$V$  = vehicle speed (m/sec)

$R_1$  = roll resistance

$R_2$  = air resistance

$R_3$  front surface resistance

$R_1 = \varphi_1 \cdot G \dots \dots \dots (\text{kg})$

$R_2 = \varphi_2 \cdot A_c \cdot V \dots \dots \dots (\varnothing)$

$R_3 = \varphi_3 \cdot A \dots \dots \dots (\varnothing)$

$\varphi_1$  = coefficient for roll resistance -- 0.08

$\varphi_2$  = air resistance coefficient -- 0.004

$\varphi_3$  = specific front surface resistance -- 217.4 kg/m<sup>3</sup>

$G$  = vehicle combined weight -- 22,130 kg

$A_c$  = vehicle front projection surface -- 9.45 m<sup>2</sup>

$A$  = snow removal cross-sectional area -- 0.687 m<sup>2</sup>.

With the snow removal speed at 20 km/hr, the power consumption on flat road is

$$R_1 = 0.08 \times 22,130 = 1,770.4 \text{ kg}$$

$$R_2 = 0.004 \times 9.45 \times \frac{20}{3.6} = 0.21 \text{ kg}$$

$$R_3 = 217.4 \times 0.687 = 149.35 \text{ kg}$$

$$P_c = \frac{20}{75 \times 3.6} (1,770.4 + 0.21 + 149.35)$$

$$= 142.2 \text{ HP}$$

The design horsepower, taking into consideration power skidding and transmission efficiency in the auger, blower and running output, is as shown in Table 2. The engine horsepower has finally put this vehicle in the 700 horsepower class.

TABLE 2.

Item	Design Value	Transmission Efficiency	Power Skid	Design Value HP
Auger	70.7	0.8	0.8	110.5
Blower	163.1	0.8	0.8	254.9
Operation	142.2	0.6	--	237.0
Auxiliary				50.0
Total				652.4

This shows power at a snow removal speed of 20 km/hr, on a flat surface and with a snow removal height of 0.25 m.

#### 4. The Structure of the Individual Parts

A mechanical description of this rotary snowplow shows that the vehicle front end is equipped with a cone ribbon screw type rotary snow removal unit, and the vehicle rear end section is loaded with machinery both for running and removing snow, as well as having the main clutch and power distribution.

As shown in Figure 4, the transmission has the following progression: the engine → the main clutch → CG type rubber coupling → power distributor. The operating power, divided into power for snow removal and power for operation, is as follows: oil pressure pump → oil pressure motor → transmission for operation.

Here the structure is divided into a front end and a back end section. The front end system is: first propellor shaft → front and rear axle differentials → governor → front and rear axles. Then it proceeds from the front and rear axle differential to the second propellor shaft → forward to the front differential → governor → into the front axles.

The rear end system is as follows: the third propellor shaft → rear axle differential → governor → rear axle.

The snow removal power is separated into the auger power and blower power through the power differential. Here the primary system consists of: first propellor shaft → the bevel gear inside the motor → second propellor shaft → chain motor → safety equipment → auger. The other system is constructed as: third propellor shaft → safety equipment → the level gear inside the motor → and the blower.

As can be seen in Figure 2, the vehicle is constructed so that it can have the snow removal equipment tilt to the right or left by the expanding and contracting of the oil pressure cylinders. This equipment uses four round link bushings. There is a simple structure for stopping rolling to the side by tie-rods. The blade, besides impeding lateral motion, can also be moved sideways by the hand-operated rods.

Figure 3 shows the chassis, Figure 5 shows the external all-around view, while Figure 4 shows the vehicle fully assembled.



Figure 2. This Shows the Tilt Condition to the Right.

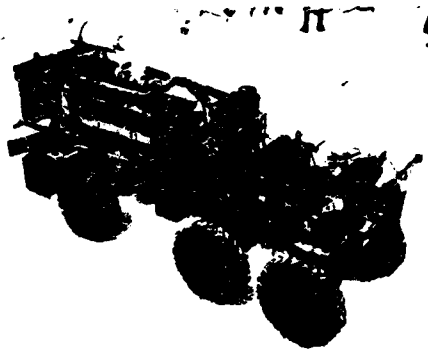

Figure 3. With the Head Up the Engine Size is Visible.

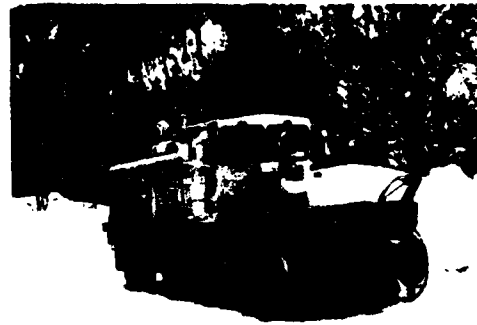

Figure 4. The HTR-700 Fully Assembled.

For reference we have published a summary of the specifications for this vehicle.

Vehicle Specifications

1. Type

HTR-700 high-speed rotary snowplow

2. Performance

Maximum amount of snow removed

3000 t/hr

Snow density	0.25 t/m <sup>2</sup>	} at
Distance snow is thrown	15 m	
Speed of snow removal	20 km/hr	
Height of snow removed	0.25 m	

Snow removal width	2750 mm
Height of the front of the snow removal machine	1700 mm
Distance snow is thrown	
1st gear	11 m
2nd gear	15 m
3rd gear	30 m

Operational speed (with front and rear drive)

1st gear	0-9.5 km/hr
2nd gear	0-29 km/hr
3rd gear	0-50 km/hr

Minimum turning radius

Minimum turning radius with outer clearance (with auger at the end)	12.8 m
Minimum turning radius of the outer vehicle (front axle as center)	10.8 m
Minimum turning radius of the inner vehicle (rear axle as center)	7.5 m
Minimum turning radius with inner clearance (rear vehicle axle fender section)	7.2 m

Grade capability 36° 30'

Maximum safe incline angle 35°

3. Specifications

Overall length (operational type)	9450 mm
Overall width	2750 mm
Overall height (up to the tip of the yellow flashing light)	3480 mm
Underside clearance (up to the bottom of the fuel tank)	350 mm

Weight

Total weight (including two operators)	22,130 kg
In front of the front axle	7450 kg
Between the front and rear axles	7450 kg
Behind the rear axle	7230 kg
Vehicle rated weight	18,255 kg
Weight of the snow removal equipment	3875 kg

Operators 2

#### 4. Parts

##### 4-1. The Vehicle Itself

Type: four-wheel drive type  
single rear engine type

##### Major specifications:

Overall length (from the tip of the frame to the rear bumper)	6590 mm
Overall width (fender width)	2350 mm
Overall height (up to the tip of the yellow flashing light)	3480 mm
Minimum underside clearance (to the bottom of the fuel tank)	350 mm

Axle length: 3300 mm

##### Tire size:

On the front of the front axle	1930 mm
On the front of the rear axle	1930 mm
The rear axle	1820 mm

##### Engine

Name of engine: Mitsubishi 12 DE 20 PTA type diesel engine

Type: four-cycle water-cooled pre-combustion type 60° V type turbo-charged behind cooler system

Number of cylinders: inner diameter x stroke is 12-150 mm x 200 mm

Total stroke capacity: 42.400 cc

Compression ratio: 17:1

##### Performance

Fixed rpm	1500 rpm
Continuous fixed output	700 HP
Operational maximum output	770 HP
Maximum torque	407 kg/m (1200 rpm)
Fuel consumption	185 gr/HP.h (all equipment functioning)

Fuel propulsion pump: Mitsubishi PEF type 2

Speed regulator: centrifugal type all-speed control

Lubrication system

Lubrication system -- forced circulation system  
Filter system -- paper filter full-flow system  
Cooling system -- water-cooled system.

Air filter -- oil tank centrifugal system 2

Cooling type -- blower driven centrifugal pump circulation

Supercharger -- Mitsubishi Schweitzer 4 HD type 2

Electrical charger -- AC 24 V 1 kW

Electrical starter -- 23 V 18 kW

Battery -- 12 V-200AH -- 4 terminals

Main clutch

Type: lubricated oil-pressure operated, detached type

Coupling

Type: CG type rubber coupling

Power distributor

Operation power transmission

Type: level gear normal mesh

Gear ratio: 0.714

Snow removal transmission

Auger

Type: level gear three-gear transmission

Gear ratio: 1st gear 3.368  
2nd gear 2.509  
3rd gear 2.074

Blower

Type: level gear three-gear transmission

Gear ratio: 1st gear 3.158  
2nd gear 2.591  
3rd gear 1.926

Oil pressure pump

Name: variable-capacity piston pump

Type: Daikin Sandstrand 25 PV, 2

Angle of inclination:  $0 \pm 18^\circ$

Output capacity (210 kg/cm<sup>2</sup>, 2100 rpm)  
325 l/min

Normal pressure: 210 kg/cm<sup>2</sup>

Maximum instantaneous pressure: 700 kg/cm<sup>2</sup>

Revolutions (engine fixed revolutions): 2100 rpm

Equipment location and operational systems -- power distributor attached directly to the right and left rear sides of the axles

Oil pressure motor

Name: fixed capacity piston motor

Type: Daikin Sandstrand 25 MF.2

Set angle of inclination:  $18^\circ$

Torque (210 kg/cm<sup>2</sup>) 53 kg/m

Normal pressure: 210 kg/cm<sup>2</sup>

Relief set pressure: 350 kg/cm<sup>2</sup>

Maximum instantaneous pressure: 700 kg/cm<sup>2</sup>

Rotation (engine fixed rotation): 2050 rpm

Location of equipment and running operation -- attached directly to the transmission input axle

Transmission

Type: level gear three-speed meshed transmission

Gear ratio: 1st gear 2.476  
2nd gear 0.780  
3rd gear 0.460

Operation

Type: front two-axle type 6 x 6 all-axle operation

### Operational equipment

On the front of the front-axle type -- all floating various gear  
joint affixed  
On the front of the rear-axle type -- all floating various gear  
joint affixed  
The rear axle type -- all floating type.

### Differential

Type: curved gearbox type

Gear ratio: 5.57

### Governor

Type: planetary gear type

Gear ratio: 5.6

### Shock-absorbtion system

Front of front axle -- half-oval heavy-duty shock absorbers  
Front of rear axle -- " " " " " "  
Rear axle -- " " " " " "

### Braking equipment

Main brakes -- oil pressure inner tension all-wheel control (air,  
double-power brakes)

Parking brakes -- mechanical outer tension axle control

### Frame

Type: grooved-steel ladder type

### Steering equipment

Type: front two axle four-wheel steering type (oil pressure booster  
attached)

Wheel location -- right side

### Tires

Type: off-road

Size: 13.00-24-18PR (all tires)

### Operator's cab

Construction -- all-enclosed light-alloy metal, two-door type

Seats -- adjustable individual seats -- 2

Oil pressure equipment

Oil pressure pumps

Type: gear type double pump -- 1

Output capacity: 140 kg/cm<sup>2</sup>, 1200 rpm) 35-35 l/min

Revolutions (engine fixed revolutions): 1200 rpm

Equipment location and operation -- timing belt operation by distributor -- left front axle

Relief valve set pressure -- 140 kg/cm<sup>2</sup>

Operating valves

Type: lever operation

Location (for snow removal equipment) upper, center, lower, floating -- 2

Location (for lower case revolving) left, center, right -- 1 each

Location (for snow cutting) open, center, closed -- 1 each

Towing equipment

Type: fixed pintle type

Capacity: 11 tons

Central height: 1220 mm

Capacity for water and oil

Water coclant	215 l
Fuel tank	900 l
Engine lubricating oil	100 l
Main clutch	26 l
Power distributor	50 l
Transmission	40 l
Differential	15 l
Governor	9 l
Operating oil	180 l
Oil pressure equipment oil	120 l

4-2. Snow Removal Equipment

Type: two stage type

Main specifications:

Overall length (from the tip of the auger to the rear of the engine)	3030 mm
Overall width	2750 mm
Overall height (to the tip of the snow cutter)	2600 mm
Weight	3875 kg

Operating equipment

Auger

Type: cone ribbon screw type

Width x outer diameter x number       $2400 \text{ mm} \times \frac{1500 \text{ mm (center section)}}{1400 \text{ mm (both tips)}} \times 1$

Blade number -- 8

Safety equipment -- Sharpin type (2)

Revolutions (engine fixed revolutions)

1st gear	132 rpm
2nd gear	170 rpm
3rd gear	214 rpm

Blower

Type: rotary type

Blower number 1

Blade outer diameter x blade inner depth 1480 x 650 mm

Blade number 5

Safety equipment -- Sharpin type (2)

Revolutions (engine fixed revolutions)

1st gear	158 rpm
2nd gear	192 rpm
3rd gear	259 rpm

Snow removal equipment lifting equipment

Type: four-point parallel link type

Operation -- oil pressure

Blade maximum lift -- 400 mm

Blade maximum cutting depth -- 50 mm

Oil pressure cylinder (for snow removal equipment lift)

Type: double

Cylinder diameter x stroke -- number -- 125 mm x 490 mm -- 2

#### Blower case

Type: release angle variable

Operational procedure -- oil pressure

Release angle adjustment range -- left 45°, right 40°

Oil pressure cylinders (for lower case rotation)

Type: modified

Cylinder diameter x stroke -- number -- 60 mm x 570 mm -- 1

#### Snow cutter

Type: left, hinged retracted type; right, fixed type

Operational procedure -- oil pressure

Blade maximum open angle -- 20°

Oil pressure cylinder (for snow cutting)

Type: modified

Cylinder diameter x stroke -- number -- 60 mm x 130 mm -- 1

#### Wheels for snow removal equipment

Type: vertically adjustable type

Adjustment play -- 40 mm up from the blade, 40 mm down

#### Wheels

Type: solid tires

Number: 2

Size: 18 x 6 x 12-1/8

Transmission system

Gears

Type: bevel gears, level gears  
Gear ratio: bevel gear -- 1.684  
Gear ratio: level gear -- 3.0

Chain gears

Type: single column roller chain type  
Speed reduction ratio -- 2.0

Oil capacity

Gears -- 20 l

Chain gears -- 8 kg (grease)

5. Driving Equipment

Levers and pedals

Steering wheel (horn button attached)	1
Clutch lever	1
Brake pedal	1
Stepless accelerator pedal	1
Forward and reverse shift lever (rear light switch attached)	1
Parking brake lever	1
Choke lever	1
Operating shift lever	1
Snow removal shift lever	2
Lever for lifting snow removal equipment	2
Blower case rotating lever	1
Snow cutting operation lever	1

Gauges and switches

Oil pressure gauge (the pilot lamp in the gear for the the engine is in the operator's cab)	1
Water temperature gauge (in the pilot lamp in the gear for the engine is in the operator's cab)	1
Ammeter (the pilot lamp indicator for the engine is inside the operator's cab)	1
Oil pressure gauge (for the oil pressure pump motor for running)	2
Oil temperature gauge (for the oil pressure pump motor for running)	1
Tachometer (electric type for the engine)	1
Speedometer (electric)	1

Air pressure gauge (the buzzer and pilot lamp indicator are in the operator's cab)	1
Fuel indicator (see-through type)	1
Service meter	1
Battery switch	1
Starter switch	1
Switch for stopping the engine	1
Switch for front lights	1
Dimmer switch	1
Dome light switch	1
Operating light switch	
Yellow flashing light switch	1
Turn indicator switch	1
Cab heater switch	2
Revolving window switch	2

Lighting equipment

Headlights	2
High-beam lights	2
Working lights	1
Turn indicators	2
Taillights and rear turn signals	2
Backup lights	1
License plate light	1
Dashboard light	1
Dome light	1
Yellow flashing light (sealed beam)	4
Spotlights	2
Outlets for spotlights	4
Rearview mirrors	2
Room mirror	1
Underbody mirror	1
Horn (air)	1

6. Miscellaneous Equipment

Cab heater (independent type can also be used for cooling, more than 5000 kcal/hr)	1
Cab heater (independent type for defrosting, more than 1300 kcal/hr)	1
Revolving windows (FS-Y, 450)	2
Tire chains (for six 13.00-24 tires)	1 set
Floor carpeting (for warmth)	1 set
Fire extinguisher (Japan-approved ABC type fire extinguishers, filled with 1.5 kg)	2
Signal flares (more than 300 candlewatts lasting 5 minutes)	1
Hand flag (red)	1
Flashlight for cab use	1

## Conclusion

After assembly this vehicle was used on the Nakayama Pass road by the Sapporo development organization, and it gave excellent results even though there were many snowslides and drifting. It fulfilled almost all the design requirements in its performance, as was expected from the test results and power calculations in our laboratory. However, there were two or three defects.

A problem developed in the dock clutch on the accelerator and power distributor. We are now redesigning this section so that it engages more firmly.

Another problem was the fact that the tire tread showed abnormal wear when tire chains were attached. We believe that this problem will not be solved unless snow tires are used. However, snow tires cannot be attached to any vehicle which has a motorized grader because of the turning radius. We believe that there is no alternative except making sure that the tire chains are properly attached.

Another problem was the fact that the main clutch did not engage properly, but this has already been modified. We believe that with all of these improvements, there will be almost no mechanical problems this year.

In any case, we have asked the operators to be careful and make sure that no unnecessary problems arise.

Finally we would like to thank the following parties for helping complete this snowplow project: this bureau's Mechanical Section, the Sapporo construction development section, the related mechanical construction companies, and the KK Japan snow removal mechanical department, which oversaw this project.

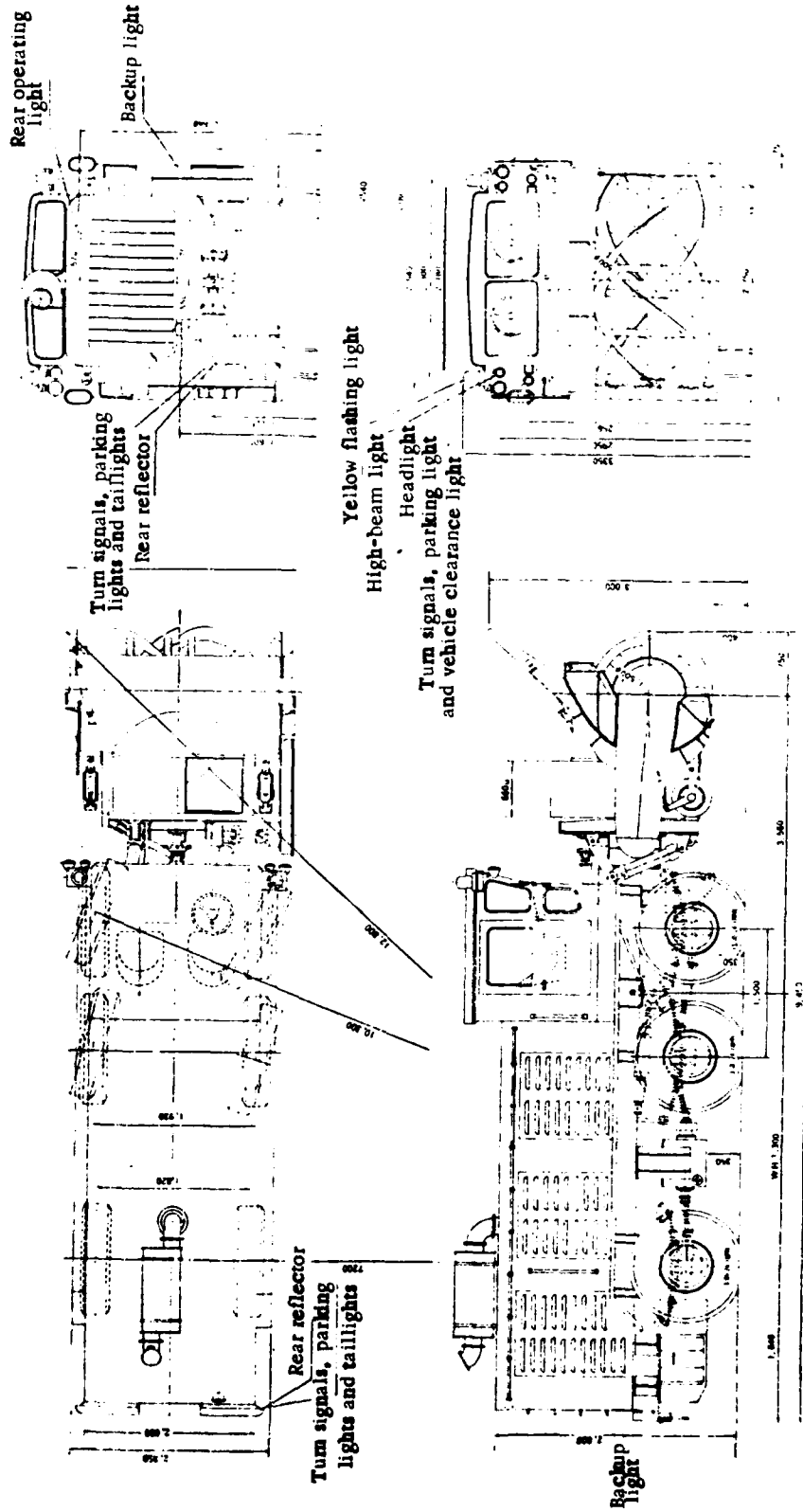

Figure 5. A Four-Way External View of the Vehicle.

DATE  
FILMED  
-88