

AD-A006 642

NAVAL POSTGRADUATE SCHOOL MONTEREY CA
THE EFFECTS OF WAVE SPREADING ON THE EXCITING FORCES ON A TENSI--ETC(U)
MAY 79 R A DIETRICH

F/G 13/10

UNCLASSIFIED

NL

1 of 1

9/2/82



END
DATE
FILMED
8-80
DTIC

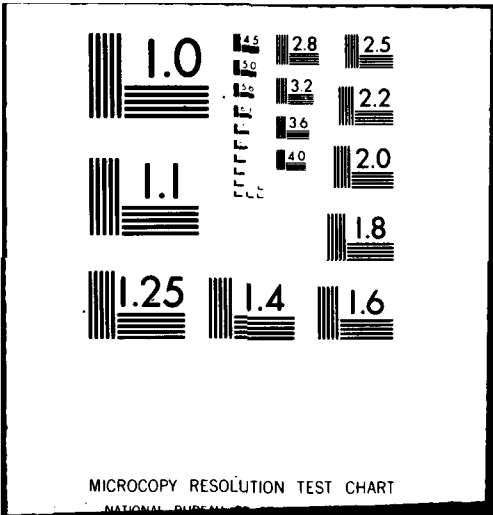

UNCLASS

2/12/1

SECURITY CLASSIFICATION OF THIS PAGE (When Data Entered)

REPORT DOCUMENTATION PAGE

READ INSTRUCTIONS BEFORE COMPLETING FORM

1. REPORT NUMBER		2. GOVT ACCESSION NO.	3. RECIPIENT'S CATALOG NUMBER
		AD-A086642	
4. TITLE (and Subtitle)		5. TYPE OF REPORT & PERIOD COVERED	
The Effects of Wave Spreading on the Exciting Forces on A Tension Leg Platform		THESIS	
7. AUTHOR(s)		6. PERFORMING ORG. REPORT NUMBER	
Rolf A./Dietrich			
9. PERFORMING ORGANIZATION NAME AND ADDRESS		10. PROGRAM ELEMENT, PROJECT, TASK AREA & WORK UNIT NUMBERS	
Massachusetts Institute of Technology Cambridge, Massachusetts		11) May 79	
11. CONTROLLING OFFICE NAME AND ADDRESS		12. REPORT DATE	
CODE 031 Naval Postgraduate School Monterey, California 93940		May 1979	
14. MONITORING AGENCY NAME & ADDRESS (if different from Controlling Office)		13. NUMBER OF PAGES	
		70	
		15. SECURITY CLASS. (of this report)	
		UNCLASS	
		15a. DECLASSIFICATION/DOWNGRADING SCHEDULE	
16. DISTRIBUTION STATEMENT (of this report)			
APPROVED FOR PUBLIC RELEASE; DISTRIBUTION UNLIMITED			
17. DISTRIBUTION STATEMENT (of the abstract entered in Block 20, if different from Report)			
1) Master's thesis			
18. SUPPLEMENTARY NOTES			
19. KEY WORDS (Continue on reverse side if necessary and identify by block number)			
Wave Spreading, Exciting Forces, Tension Leg Platform			
20. ABSTRACT (Continue on reverse side if necessary and identify by block number)			
SEE REVERSE			

ADA 086642

LEVEL 14

DTIC ELECTED JUL 15 1980

DDC FILE COPY

ABSTRACT

Oil exploration in water deeper than 1000 feet has motivated the development of drilling platforms with dynamic responses superior to those of the conventional jacket structures. One of the most promising of these is the tension leg platform (TLP), a semi-submersible platform held in place by tension members connected to the ocean bottom.

This thesis evaluates the wave force transfer function for the TLP in heave, pitch, and roll motions. This is accomplished by assuming the transfer function for a single leg and then extending that result to include the effect of phase differences between forces on multiple legs, including the effect of wave spreading.

Cosine squared directional wave spreading is discussed and then dismissed in favor of a Gaussian distribution of wave direction. Using the Gaussian distribution it is shown that when the wave spreading has a standard deviation greater than 0.5 radian the exciting force transfer functions in heave, pitch, and roll converge rapidly to that computed for seas uniformly distributed over all incidence angles.

Accession For	
NTIS GRA&I	<input checked="" type="checkbox"/>
DDC TAB	<input type="checkbox"/>
Unannounced	<input type="checkbox"/>
Justification	
By _____	
Distribution/	
Availability Codes	
Dist.	Avail. and/or special
A	

DD Form 1473
 Jan 73
 S/N 0102-014-6601

THE EFFECTS OF WAVE SPREADING
ON THE EXCITING FORCES
ON A TENSION LEG PLATFORM

by

Rolf A. Dietrich

J. Kim Vandiver
Thesis Supervisor

Approved for public release;
distribution unlimited.

Approved for public release;
distribution unlimited.

THE EFFECTS OF WAVE SPREADING
ON THE EXCITING FORCES
ON A TENSION LEG PLATFORM

by

ROLF A. DIETRICH
Lieutenant, U. S. Navy

B.S., U. S. Naval Academy
(1974)

SUBMITTED IN PARTIAL FULFILLMENT
OF THE REQUIREMENTS FOR THE DEGREES OF

MASTER OF SCIENCE
in
OCEAN ENGINEERING

AND

MASTER OF SCIENCE
in
MECHANICAL ENGINEERING

at the

MASSACHUSETTS INSTITUTE OF TECHNOLOGY

MAY 1979

© Rolf A. Dietrich

Signature of Author..... *Rolf A. Dietrich*
Department of Ocean Engineering, May 11, 1979

Certified by..... *J. Kim Vandiver*
Thesis Supervisor

Certified by..... *Richard H. Lyon*
Department Reader

Accepted by.....
Chairman, Department Committee

THE EFFECT OF WAVE SPREADING ON THE EXCITING FORCES
ON A TENSION LEG PLATFORM

by

ROLF A. DIETRICH

Submitted to the Department of Ocean Engineering
and the Department of Mechanical Engineering
on May 11, 1979, in partial fulfillment of the requirements
for the Degree of Master of Science.

ABSTRACT

Oil exploration in water deeper than 1000 feet has motivated the development of drilling platforms with dynamic responses superior to those of the conventional jacket structures. One of the most promising of these is the tension leg platform (TLP), a semi-submersible platform held in place by tension members connected to the ocean bottom.

This thesis evaluates the wave force transfer function for the TLP in heave, pitch, and roll motions. This is accomplished by assuming the transfer function for a single leg and then extending that result to include the effect of phase differences between forces on multiple legs, including the effect of wave spreading.

Cosine squared directional wave spreading is discussed and then dismissed in favor of a Gaussian distribution of wave direction. Using the Gaussian distribution it is shown that when the wave spreading has a standard deviation greater than 0.5 radian the exciting force transfer functions in heave, pitch, and roll converge rapidly to that computed for seas uniformly distributed over all incidence angles.

Thesis Supervisor: J. Kim Vandiver
Title: Assistant Professor of Ocean Engineering

Department Reader: Richard H. Lyon
Title: Professor of Mechanical Engineering

ACKNOWLEDGEMENTS

The author wishes to thank the many people whose advice and encouragement contributed so much to this study. Particular appreciation goes to Professor J. Kim Vandiver who, as thesis supervisor, provided sound technical advice and valuable criticism, and to Professor Richard H. Lyon who, as reader, provided additional insight into the problem.

A special thanks goes to the author's wife, Gayle, who so patiently typed this manuscript and to MIT Graphic Arts for efficiently duplicating it.

TABLE OF CONTENTS

	<u>Page</u>
Title Page	1
Abstract	2
Acknowledgements	4
Table of Contents	5
List of Tables and Figures	6
I. Introduction	7
II. Problem Statement	10
III. Formulation of Equations	12
IV. Numerical Prediction of Exciting Forces	33
V. Suggestions for Experimental Verification	47
VI. Conclusions	49
Nomenclature	53
References	55
Appendix I. Computer Program Listing	56
Appendix II. Directions on use of Computer Program	63
Appendix III. Gauss-Legendre Quadrature	67

LIST OF TABLES AND FIGURES

	<u>Page</u>
Figure I-1 Tension Leg Platform	9
Figure III-1 Regular Waves Incident on TLP	13
Figure III-2 Cosine Squared Spreading	22
Figure III-3 Gaussian Spreading	22
Figure III-4 Correction Factor for Loss of Gaussian Tails	25
Table IV-1 Normalized Platform Heave Exciting Force (D=160 feet, Per=2.0 sec, $\sigma=0.65$ rad.)	39
Table IV-2 Normalized Platform Roll Exciting Moment (D=160 feet, Per=2.0 sec, $\sigma=0.65$ rad.)	40
Table IV-3 Normalized Platform Heave Exciting Force (Various leg spacings)	41
Table IV-4 Normalized Platform Roll Exciting Moment (Various leg spacings)	42
Table IV-5 Normalized Platform Heave Exciting Force (Various periods)	43
Figure IV-6 Normalized Platform Roll Exciting Moment (Various periods)	44
Figure IV-7 Normalized Platform Heave Exciting Force (Various standard deviations)	45
Figure IV-8 Normalized Platform Roll Exciting Moment (Various standard deviations)	46

I. Introduction

Present day platforms, in water depths from 10 to 1000 feet, are primarily of welded steel jacket construction. As the present limit of about 1000 feet was approached many problems in fabrication and installation were encountered, indicating the need for a shift to a new technology. More significantly, with increasing water depth the natural periods of jacket platforms increase from about one second in 100 feet of water to approximately four seconds in 1000 feet of water. There is significant wave energy with a period of four seconds and dynamic amplification becomes a problem. The expected life of the structure is shortened due to high cycle - low stress fatigue damage.

One alternative structure is a tension leg platform (TLP). A TLP (see Figure I-1) is a bouyant structure held in position by tension members secured to the ocean bottom. Because the platform is not rigidly connected to the bottom its natural modes of vibration are significantly different from a jacket structure of similar height. A TLP in a water depth on the order of 1000 feet will have natural periods in heave, pitch, and roll of about two seconds, well out of the region of high wave energies.

Since the TLP has only recently been accepted as a potential alternative for deep water drilling there are few studies of its dynamic response to wave forces. Such preliminary studies are necessary to provide information for the design of the operating platforms. Response prediction requires specification of the modal exciting forces, for example in pitch, roll, and heave. For low everyday sea states the exciting forces and structure responses can be considered to behave in a linear fashion. Linearity of excitation and response suggests that a frequency domain solution technique is appropriate; especially when one considers that ocean waves are a random process most often described by a wave amplitude spectrum. This thesis presents an estimate of the modal exciting force spectra in heave, pitch, and roll in a way which accounts for structure geometry and wave spreading.

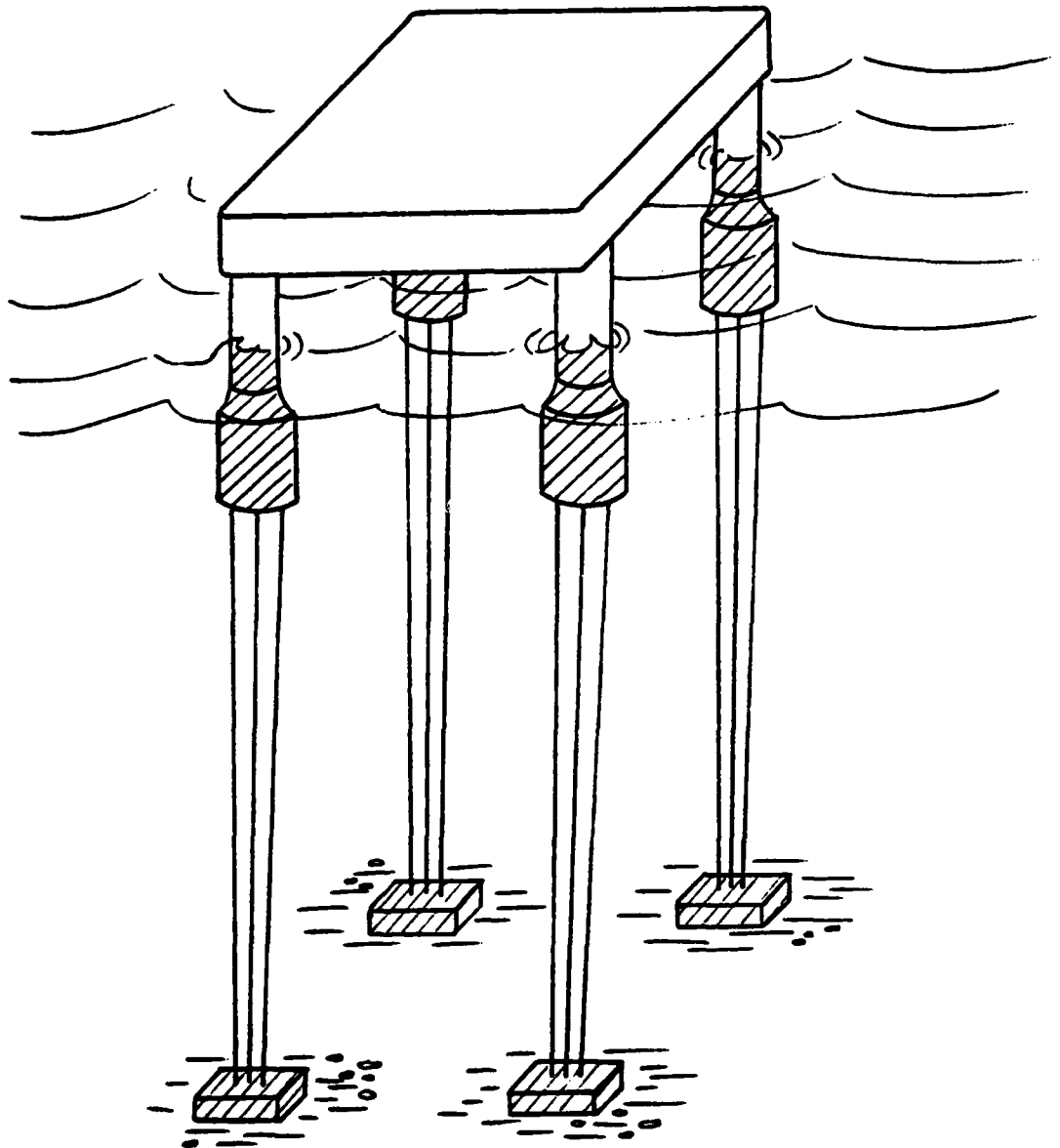

Figure I-1 Tension Leg Platform

II. Problem Statement

The modal exciting forces on a tension leg platform (TLP) will be dependent upon the frequency and the angles of incidence of the incoming waves. For some angles of incidence (at a given frequency) the forces on the various legs will act together to produce a larger total force or moment. For other angles of incidence the phase differences will cause the forces or moments exerted on the various legs to cancel, tending to produce a smaller total force.

In this report the total modal force of the platform in heave, pitch, and roll will be divided into two parts. The first will be the force exerted upon a single, isolated leg by waves of the given frequency. The second will be a geometric term to take into account the effect of the phase differences between forces on each of the legs. This second term will be specifically calculated for a square TLP noting that the method could be used for any shape.

The calculations so far imply a unidirectional wave amplitude spectrum. Rarely is this observed in practice. A reasonable wave spectrum can be approximated as being centered about one bearing from the structure and

diminishing to zero at bearings 90° either side of the central bearing. Two types of wave spreading functions will be discussed. The first is the cosine squared spreading law which, although widely used, allows little if any leeway in varying the spreading to fit actual measurements. The second is the Gaussian distribution which does allow continuous variation of spreading simply by changing the standard deviation.

The modal wave force spectra upon the structure will be the integral over all incidence angles of the directional wave amplitude spectra, weighted appropriately by the platform heave force, roll or pitch moment transfer functions. The resulting spectra will be normalized in this thesis by the results obtained when a uniformly spread wave spectrum is used. This is done to demonstrate the effect of wave spreading on the heave, pitch, and roll exciting force spectra.

III. Formulation of Equations

A. Platform transfer function

1. Single leg transfer function. The single leg wave amplitude to vertical force transfer function, $\Gamma_s(\omega)$, is a function only of wave frequency. Because the leg has circular cross sections there is no dependence on β , the angle of incidence. This thesis assumes that $\Gamma_s(\omega)$ is available, either experimentally or through another approximation method.

2. Square platform transfer function. Consider plane progressive waves of frequency ω coming from an angle β off the platform axis. See Figure III-1. Each leg is thus subject to waves of the same frequency but different phase. For deep water waves the wavenumber is $k = \frac{2\pi}{\lambda} = \frac{\omega^2}{g}$. Thus the wavelength is

$$\lambda = \frac{2\pi g}{\omega^2} .$$

The phase shift in one wavelength is 2π . The phase shift, ϕ_i , due to a distance, l_i , along the axis of propagation is thus

$$\phi_i = \frac{2\pi l_i}{\lambda} = \frac{\omega^2}{g} l_i$$

Consider the center of the platform as the point of zero phase shift. Let d be the leg spacing and $a = d/\sqrt{2}$ be the

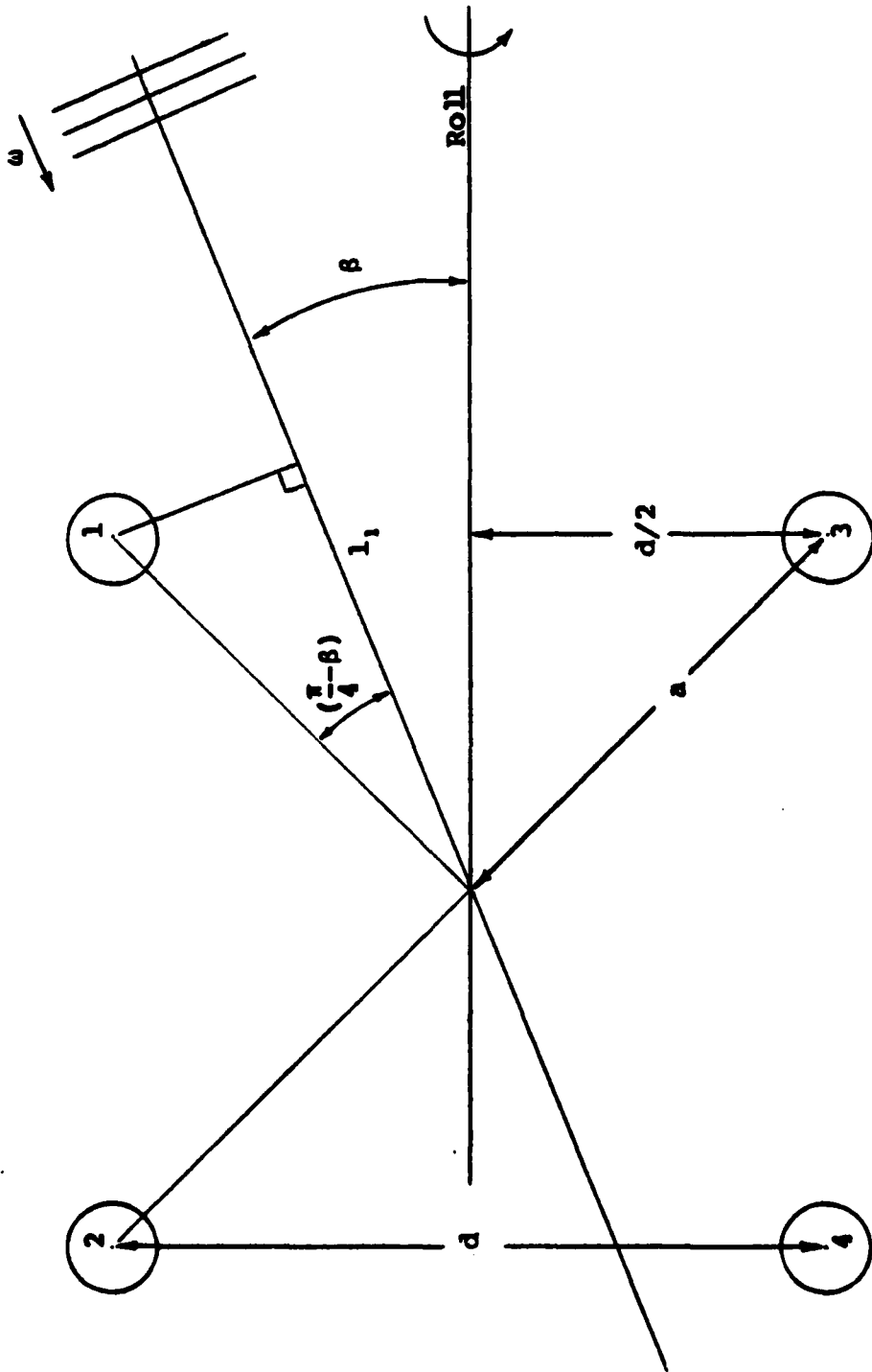

Figure III-1 Regular Waves Incident on TLP

distance from the center of the platform to the center of any leg.

The distance causing a phase shift for leg 1 is

$$l_1 = a \cos\left(\frac{\pi}{4} - \beta\right). \text{ For leg 2 it is } l_2 = -a \sin\left(\frac{\pi}{4} - \beta\right).$$

Similarly for legs 3 and 4 the lengths are $l_3 = a \sin\left(\frac{\pi}{4} - \beta\right)$

and $l_4 = -a \cos\left(\frac{\pi}{4} - \beta\right)$. From Equation III-1 the phase

shifts are:

$$\phi_1 = \frac{\omega^2}{g} a \cos\left(\frac{\pi}{4} - \beta\right)$$

$$\phi_2 = -\frac{\omega^2}{g} a \sin\left(\frac{\pi}{4} - \beta\right)$$

$$\phi_3 = \frac{\omega^2}{g} a \sin\left(\frac{\pi}{4} - \beta\right)$$

$$\phi_4 = -\frac{\omega^2}{g} a \cos\left(\frac{\pi}{4} - \beta\right)$$

III-2

Note however that:

$$\begin{aligned} \cos\left(\frac{\pi}{4} - \beta\right) &= \cos\left(\frac{\pi}{4}\right)\cos(\beta) + \sin\left(\frac{\pi}{4}\right)\sin(\beta) \\ &= (\sqrt{2}/2)\{\cos(\beta) + \sin(\beta)\} \end{aligned}$$

$$\begin{aligned} \sin\left(\frac{\pi}{4} - \beta\right) &= \sin\left(\frac{\pi}{4}\right)\cos(\beta) - \cos\left(\frac{\pi}{4}\right)\sin(\beta) \\ &= (\sqrt{2}/2)\{\cos(\beta) - \sin(\beta)\} \end{aligned}$$

Letting $T = \omega^2 d/g$ and recalling $a = (\sqrt{2}/2)d$ then

Equations III-2 become:

$$\phi_1 = \frac{T}{2} (\cos(\beta) + \sin(\beta))$$

$$\phi_2 = -\frac{T}{2} (\cos(\beta) - \sin(\beta))$$

$$\phi_3 = \frac{T}{2} (\cos(\beta) - \sin(\beta))$$

$$\phi_4 = -\frac{T}{2} (\cos(\beta) + \sin(\beta)) \quad \text{III-3}$$

3. Heave. The transfer function for heave for the total structure, Γ_{ht} , is the sum of the contributions of each leg. Taking phase into consideration each leg contributes $\Gamma_s \exp\{i(\omega t + \phi_i)\}$. Thus the quantity of interest, the square of the magnitude of Γ_{ht} , is

$$|\Gamma_{ht}|^2 = |\Gamma_s|^2 |e^{i\phi_1} + e^{i\phi_2} + e^{i\phi_3} + e^{i\phi_4}|^2.$$

Incorporating the identity $e^{i\phi} = \cos(\phi) + i \sin(\phi)$, summing real and imaginary parts, and taking the magnitude squared of the exponentials this becomes

$$|\Gamma_{ht}|^2 = |\Gamma_s|^2 \{(\cos(\phi_1) + \cos(\phi_2) + \cos(\phi_3) + \cos(\phi_4))^2 + (\sin(\phi_1) + \sin(\phi_2) + \sin(\phi_3) + \sin(\phi_4))^2\} \quad \text{III-4}$$

Note however from Equation III-3 that $\phi_4 = -\phi_1$ and $\phi_2 = -\phi_3$. Thus we have

$$\begin{aligned} \cos(\phi_1) &= \cos(\phi_0) & \sin(\phi_1) &= -\sin(\phi_0) \\ \cos(\phi_2) &= \cos(\phi_0) & \sin(\phi_2) &= -\sin(\phi_0) \end{aligned}$$

and Equation III-4 becomes

$$\begin{aligned} |\Gamma_{ht}|^2 &= |\Gamma_s|^2 \{2 \cos(\phi_1) + 2 \cos(\phi_2)\}^2 \\ |\Gamma_{ht}|^2 &= 4 |\Gamma_s|^2 \{\cos(\phi_1) + \cos(\phi_2)\}^2. \end{aligned} \quad \text{III-5}$$

By replacing ϕ_1 and ϕ_2 with their values from Equation III-3 and setting $R_h = |\Gamma_{ht}|^2/|\Gamma_s|^2$ this becomes

$$\begin{aligned} R_h &= 4 \left\{ \cos\left(\frac{T}{2}(\cos \beta + \sin \beta)\right) + \cos\left(\frac{T}{2}(\cos \beta - \sin \beta)\right) \right\}^2 \\ R_h &= 4 \left\{ \cos\left(\frac{T}{2} \cos \beta\right) \cos\left(\frac{T}{2} \sin \beta\right) - \sin\left(\frac{T}{2} \cos \beta\right) \sin\left(\frac{T}{2} \sin \beta\right) \right. \\ &\quad \left. + \cos\left(\frac{T}{2} \cos \beta\right) \cos\left(\frac{T}{2} \sin \beta\right) + \sin\left(\frac{T}{2} \cos \beta\right) \sin\left(\frac{T}{2} \sin \beta\right) \right\}^2 \\ R_h &= 4 \left\{ 2 \cos\left(\frac{T}{2} \cos \beta\right) \cos\left(\frac{T}{2} \sin \beta\right) \right\}^2 \end{aligned} \quad \text{III-6}$$

A form often more suitable for computer work is obtained by applying the identity $\cos^2 A = \frac{1}{2} + \frac{1}{2} \cos 2A$ yielding

$$|\Gamma_{ht}|^2 = 4 (1 + \cos(T \cos \beta)) (1 + \cos(T \sin \beta)) |\Gamma_s|^2 \quad \text{III-7}$$

which can be implemented by recalling that $T = \omega^2 d/g$.

4. Horizontal force assumptions. The roll and pitch moments experienced by a TLP will be dependent upon horizontal as well as vertical forces. In this report it has been assumed that the total moment producing effect of the horizontal force is small compared to the vertical forces. This is perhaps not always the case but is assumed in this discussion because, while the horizontal wave forces may be large, they are distributed along the legs, both above and below the center of rotation of the platform. The force on the leg near the surface is large but with a small moment arm. The forces below the center of rotation will be smaller but will extend further down the leg and thus have a large moment arm, producing a moment similar in magnitude but opposite in sign, and will tend to cancel the other. Thus the moment producing effects of the horizontal forces are assumed to be significantly smaller than those of the vertical forces. When the location of the center of rotation and the roll and pitch natural periods are known, as they would be for any particular TLP design, the horizontal contribution to the roll and pitch moment could be calculated. It can be shown that the phase angles encountered when adding up the moments generated by the horizontal forces on each of the four legs would be the same as calculated previously for heave. Therefore the

results computed for heave will serve as a check on the qualitative behavior of the role of horizontal forces in the generation of roll and pitch exciting forces.

5. Pitch and roll. Pitch and roll for a square platform are exactly symmetric. Thus only roll will be discussed here with the understanding that pitch could be obtained by shifting the coordinates by 90 degrees. Taking the direction of positive roll moment to be as shown in Figure III-1 the total transfer function for roll, squared, would be

$$\begin{aligned} |\Gamma_{rt}|^2 &= |\Gamma_s|^2 |(d/2)e^{i\phi_1} + (d/2)e^{i\phi_2} + (-d/2)e^{i\phi_3} + (-d/2)e^{i\phi_4}|^2 \\ &= |\Gamma_s|^2 \frac{d^2}{4} |e^{i\phi_1} + e^{i\phi_2} - e^{i\phi_3} - e^{i\phi_4}|^2 \end{aligned}$$

Let $R_r = |\Gamma_{rt}|^2 / |\Gamma_s|^2$. Incorporating the identity $e^{i\phi} = \cos \phi + i \sin \phi$, summing the real and imaginary parts, and taking the magnitude squared this becomes

$$\begin{aligned} R_r &= \frac{d^2}{4} \{(\cos \phi_1 + \cos \phi_2 - \cos \phi_3 - \cos \phi_4)^2 \\ &\quad + (\sin \phi_1 + \sin \phi_2 - \sin \phi_3 - \sin \phi_4)^2\} \quad \text{III-8} \end{aligned}$$

However, from equations III-3 $\phi_3 = -\phi_1$ and $\phi_4 = -\phi_2$. Thus $\cos \phi_3 = \cos \phi_1$, $\cos \phi_4 = \cos \phi_2$, $\sin \phi_3 = -\sin \phi_1$, and $\sin \phi_4 = -\sin \phi_2$. Therefore the cosine term in Equation III-8 reduces to zero and the sine term becomes $(2 \sin \phi_1 + 2 \sin \phi_2)^2$, leaving

$$R_r = d^2 (\sin \phi_1 + \sin \phi_2)^2.$$

Incorporating the values from Equations III-3 this becomes

$$R_r = d^2 \left(\sin\left(\frac{T}{2}(\cos \beta + \sin \beta)\right) + \sin\left(-\frac{T}{2}(\cos \beta - \sin \beta)\right) \right)^2$$

$$R_r = d^2 \left(\sin\left(\frac{T}{2}\cos \beta\right)\cos\left(\frac{T}{2}\sin \beta\right) + \cos\left(\frac{T}{2}\cos \beta\right)\sin\left(\frac{T}{2}\sin \beta\right) \right. \\ \left. + \sin\left(-\frac{T}{2}\cos \beta\right)\cos\left(\frac{T}{2}\sin \beta\right) + \cos\left(-\frac{T}{2}\cos \beta\right)\sin\left(\frac{T}{2}\sin \beta\right) \right)^2$$

$$R_r = d^2 \left(\sin\left(\frac{T}{2}\cos \beta\right)\cos\left(\frac{T}{2}\sin \beta\right) + \cos\left(\frac{T}{2}\cos \beta\right)\sin\left(\frac{T}{2}\sin \beta\right) \right. \\ \left. - \sin\left(\frac{T}{2}\cos \beta\right)\cos\left(\frac{T}{2}\sin \beta\right) + \cos\left(\frac{T}{2}\cos \beta\right)\sin\left(\frac{T}{2}\sin \beta\right) \right)^2$$

$$R_r = 4 d^2 \cos^2\left(\frac{T}{2}\cos \beta\right)\sin^2\left(\frac{T}{2}\sin \beta\right) \quad \text{III-9}$$

By applying the identities $\cos^2 A = \frac{1}{2} + \frac{1}{2} \cos 2A$ and $\sin^2 A = \frac{1}{2} - \frac{1}{2} \cos 2A$ this yields a form more suitable for computer work.

$$|\Gamma_{rt}|^2 = d^2 \{1 + \cos(T \cos \beta)\} \{1 - \cos(T \sin \beta)\} |\Gamma_s|^2$$

III-10

As mentioned previously pitch is simply rotated by 90 degrees. Thus $\cos \beta$ becomes $\sin \beta$ and $\sin \beta$ becomes $-\cos \beta$. The transfer function for pitch for a square platform is thus

$$|\Gamma_{pt}|^2 = d^2 \{1 - \cos(T \cos \beta)\} \{1 + \cos(T \sin \beta)\} |\Gamma_s|^2.$$

III-11

B. Wave spectrum.

The wave spectrum incident on the platform varies with both frequency and direction and is denoted $S_n(\omega, \beta, \beta_0)$. β_0 is the center of an arc of 180° from which the waves are coming.

For simplicity of calculations it is often assumed, as it shall be in this report, that the total wave spectrum can undergo separation of variables. Thus we can express the spectrum as

$$S_n(\omega, \beta, \beta_0) = S_n(\omega) F(\beta, \beta_0)$$

where the entire frequency dependence is contained in $S_n(\omega)$ and the entire angular dependence is in $F(\beta, \beta_0)$. This section deals with approximations for the angular dependence, $F(\beta, \beta_0)$.

1. Cosine squared wave spectrum. An often used method for describing the angular spreading of waves is the cosine squared wave spectrum (see Figure III-2). It has the advantage that it vanishes for values of β equal to plus and minus $\pi/2$. The formula for the cosine squared spectrum is

$$S_n(\omega, \beta, \beta_0) = C p(\beta, \beta_0) S_n(\omega) ; \quad -\pi/2 \leq \beta - \beta_0 \leq \pi/2$$

where β_0 is the center of the wave spectrum and C is a constant

used to normalize to unity the area between $-\pi/2$ and $\pi/2$.

It is derived as follows:

$$1 = \int_{-\pi/2}^{\pi/2} C \cos^2(\beta) d\beta$$

$$\frac{1}{C} = 2 \int_0^{\pi/2} \cos^2(\beta) d\beta = 2 \left(\frac{\pi}{4}\right)$$

$$C = \frac{2}{\pi} .$$

Thus the equation for the cosine squared spectrum is

$$S_n(\omega, \beta, \beta_0) = \frac{2}{\pi} S_n(\omega) \cos^2(\beta - \beta_0) ; -\frac{\pi}{2} \leq (\beta - \beta_0) \leq \frac{\pi}{2}$$

III-12

This spectrum suffers from one major disadvantage.

It cannot allow for variations in the directionality of the waves. This problem can be eased somewhat by considering cosine to the fourth, to the sixth, and so forth but this results in only step changes in the directionality. Methods have been designed to provide continuous changes but they are somewhat cumbersome and comparison is not apparent.

2. Gaussian wave spectrum. The method used in this report to achieve continuous changes in directionality is to consider the waves to be spread about the central angle β_0 in a Gaussian fashion with standard deviation σ . The reader not

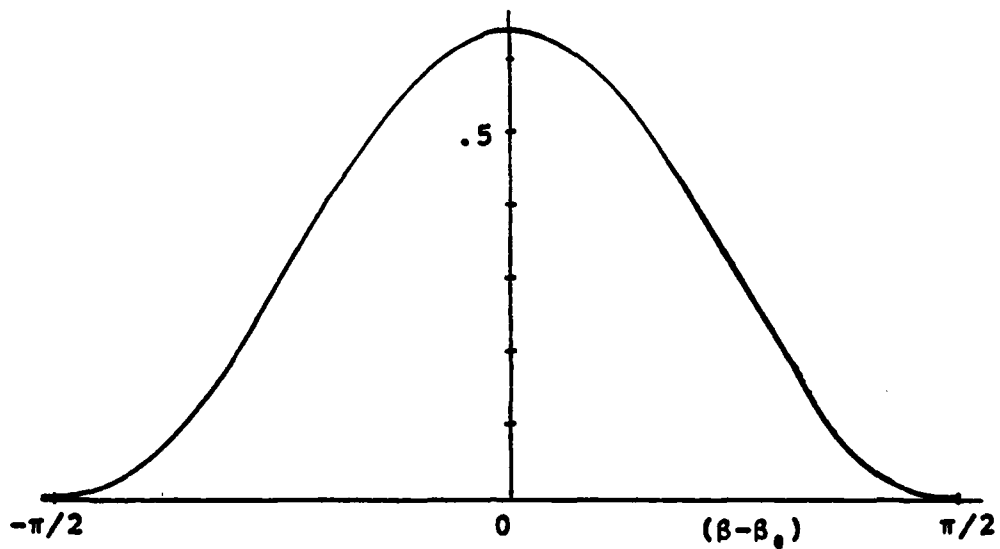

Figure III-2 Cosine Squared Spreading

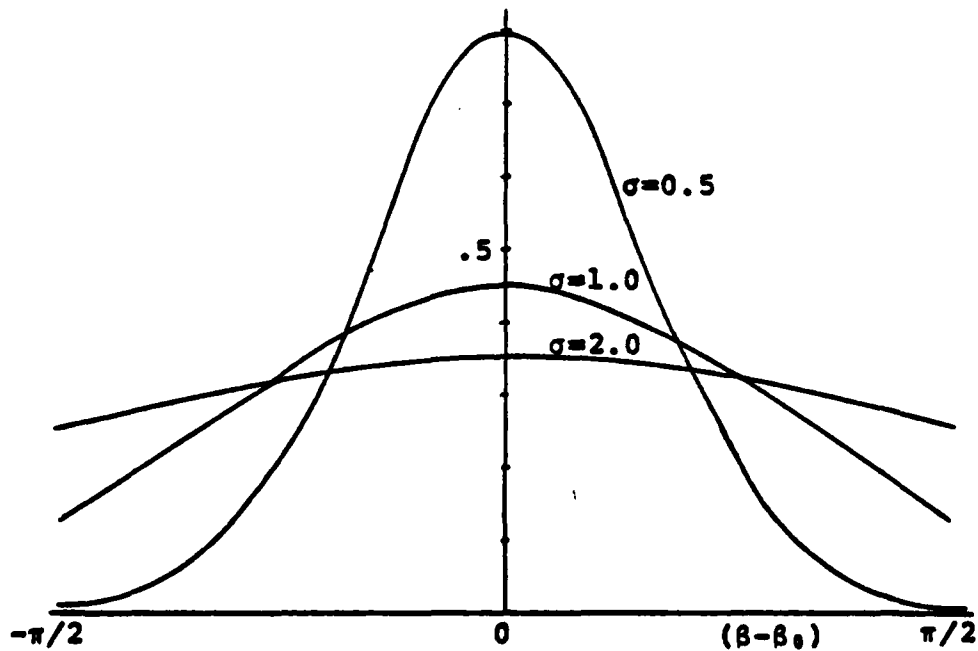

Figure III-3 Gaussian Spreading

familiar with Gaussian (or normal) distributions may wish to refer to any good probability text for an explanation more detailed than the following.

The probability distribution of a Gaussian process with mean β_0 and standard deviation σ is described by

$$p(\beta, \beta_0) = \frac{1}{\sqrt{2\pi} \sigma} \exp\left(-(\beta - \beta_0)^2 / (2\sigma^2)\right)$$

A spectrum of waves defined by a Gaussian process would thus be

$$S_n(\omega, \beta, \beta_0) = C p(\beta, \beta_0) S_n(\omega) ; -\pi/2 < \beta - \beta_0 < \pi/2 \quad \text{III-13}$$

where again C is a constant to normalize to unity the area between $-\pi/2$ and $\pi/2$. It is derived as follows, referencing β_0 to zero:

$$1 = \int_{-\pi/2}^{\pi/2} C p(\beta, \beta_0) d\beta$$

$$\frac{1}{C} = \int_{-\pi/2}^{\pi/2} p(\beta, \beta_0) d\beta$$

This integral is evaluated using the properties of the Gaussian distribution and yields

$$C = \frac{1}{2 \phi\left(\frac{\pi}{2\sigma}\right) - 1}$$

where $\phi(x) = \frac{1}{\sqrt{2\pi}} \int_{-\infty}^x \exp(-t^2/2) dt$

is known as the normal distribution function and is tabulated in probability texts and math tables. Thus C is a function of the standard deviation and shall hereafter be denoted C(σ).

Unlike the cosine squared spreading the Gaussian distribution does not vanish for β equal to plus and minus $\pi/2$. This is why C(σ) varies with σ . It must account for the cropping of the "tails" of the distribution for $|\beta| > \pi/2$.

Some simplifying approximations can be made however. As can be seen from Figure III-3 when σ reaches a value of 2 or larger the angular spectrum approaches a constant value. That value is $1/\pi$ (in order to achieve unity area). Thus Equation III-13 becomes

$$S_n(\omega, \beta, \beta_0) = \frac{1}{\pi} S_n(\omega) ; \quad -\frac{\pi}{2} < \beta - \beta_0 < \frac{\pi}{2} \quad \text{for } \sigma > 2.$$

For $\sigma < 1$ the area in the tails diminishes rapidly leaving almost all of the area between $-\pi/2$ and $\pi/2$. As can be seen in Figure III-4 C(σ) rapidly approaches unity. For $\sigma=1.0$ C=1.13. For $\sigma=0.9$ C=1.09. So for $\sigma < 1$ Equation III-13 can be approximated by

$$S_n(\omega, \beta, \beta_0) = S_n(\omega) \left\{ \frac{1}{\sqrt{2\pi} \sigma} \right\} \exp\left\{ \frac{-(\beta - \beta_0)^2}{2\sigma^2} \right\} .$$

For values of σ between 1 and 2 the entire exact formula must be used

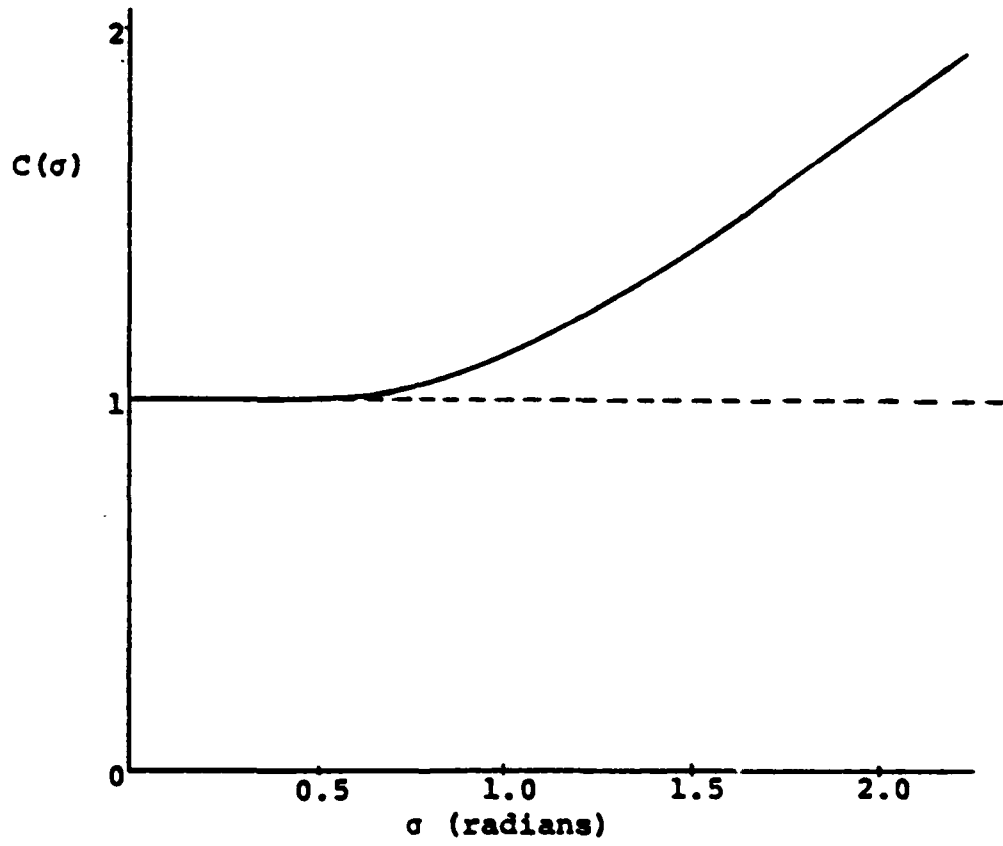

Figure III-4 Correction Factor for Loss of Gaussian Tails

$$S_n(\omega, \beta, \beta_0) = S_n(\omega) \left\{ \frac{1}{2 \phi\left(\frac{\pi}{2}\right) - 1} \right\} \left\{ \frac{1}{\sqrt{2\pi} \sigma} \right\} \exp\left\{ \frac{-(\beta - \beta_0)^2}{2\sigma^2} \right\} \quad \text{III-14}$$

3. Comparison of cosine squared with Gaussian. Since many people are familiar with cosine squared spreading it is useful to discuss for what values of σ the Gaussian would approximate the cosine squared. Although the two functions are quite distinct there are several possible methods to compare them.

The normalized cosine squared distribution has a value of $2/\pi = 0.637$ for $\beta = \beta_0$. For Gaussian spreading this would be $C(\sigma) / (\sqrt{2\pi} \sigma)$ at $\beta = \beta_0$. If σ is assumed less than 1 then $C(\sigma) = 1$. Equating the two values yields $\sigma = 0.627$.

When $\beta = \beta_0 + \pi/4$ the cosine squared distribution is half of its maximum value. This situation can be matched with a Gaussian yielding still another "equivalent" σ for the cosine squared.

$$\frac{C(\omega)}{\sqrt{2\pi} \sigma} \exp\left\{ \frac{-(\pi/4)^2}{2\sigma^2} \right\} = (0.5) \frac{C(\omega)}{\sqrt{2\pi} \sigma}$$

$$\exp\left\{ \frac{-(\pi/4)^2}{2\sigma^2} \right\} = (0.5)$$

$$\sigma = \left\{ \frac{-(\pi/4)^2 (1/2)}{\ln(0.5)} \right\}^{1/2}$$

$$\sigma = 0.667$$

The two values obtained are approximately equal. Thus the Gaussian distribution with $\sigma=0.65$ is very similar to the more familiar cosine squared distribution. A smaller σ means a more unidirectional wave front and a larger σ means more spreading.

C. Platform exciting forces.

Each differential element of the spectrum $S_n(\omega, \beta, \beta_0) d\beta$ induces mean square force or moment upon the platform through the appropriate platform modal force transfer function, magnitude squared, $|\Gamma_t(\omega, \beta)|^2$. Thus the total force or moment spectrum is given by

$$H(\omega, \beta_0) = \int_{-\pi}^{\pi} |\Gamma_t(\omega, \beta)|^2 S_n(\omega, \beta, \beta_0) d\beta \quad \text{III-15}$$

It is important to note that this modal force spectrum is dependent upon β_0 , the center of the directional spectrum.

1. Square platform, heave force. The heave force spectrum for a square platform in normally distributed waves is derived by substituting Equations III-7 and III-14 into Equation III-15 yielding:

$$H_h(\omega, \beta_0) = \int_{\beta_0 - \pi/2}^{\beta_0 + \pi/2} |\Gamma_s|^2 4(1 + \cos(T \cos \beta))(1 + \cos(T \sin \beta)) \times$$

$$S_n(\omega) \left\{ \frac{1}{2 \phi(\frac{\pi}{2}) - 1} \right\} \left\{ \frac{1}{\sqrt{2\pi} \sigma} \right\} \exp\left\{ -\frac{(\beta - \beta_0)^2}{2 \sigma^2} \right\} d\beta$$

$$H_h(\omega, \beta_0) = 4 |\Gamma_s|^2 S_n(\omega) \frac{C(\sigma)}{\sqrt{2\pi} \sigma} \times$$

$$\int_{\beta_0 - \pi/2}^{\beta_0 + \pi/2} \{1 + \cos(T \cos \beta)\} \{1 + \cos(T \sin \beta)\} \exp\left\{-\frac{(\beta - \beta_0)^2}{2\sigma^2}\right\} d\beta \quad \text{III-16}$$

Setting $I_h(\omega, \beta_0)$ equal to the integral in Equation III-16 and expanding the integrand yields

$$I_h(\omega, \beta_0) = \int_{\beta_0 - \pi/2}^{\beta_0 + \pi/2} \{1 + \cos(T \cos \beta) + \cos(T \sin \beta) + \cos(T \cos \beta) \cos(T \sin \beta)\} \exp\left\{-\frac{(\beta - \beta_0)^2}{2\sigma^2}\right\} d\beta \quad \text{III-17}$$

where $H_h(\omega, \beta_0) = 4 |\Gamma_s|^2 S_n(\omega) \frac{C(\sigma)}{\sqrt{2\pi} \sigma} I_h(\omega, \beta_0)$.

A closed form solution of Equation III-17 does not exist. Thus a numerical integration was necessary (see Section IV).

2. Square platform, roll moment. Similarly the roll moment spectrum for a square platform in normally distributed waves is derived by substituting Equations III-10 and III-14 into Equation III-15 yielding:

$$H_r(\omega, \beta_0) = \int_{\beta_0 - \pi/2}^{\beta_0 + \pi/2} d^2 \{1 + \cos(T \cos \beta)\} \{1 - \cos(T \sin \beta)\} |\Gamma_s|^2 \times \\ S_n(\omega) \left\{ \frac{1}{2 \phi(\frac{\pi}{2}) - 1} \right\} \left\{ \frac{1}{\sqrt{2\pi} \sigma} \right\} \exp\left\{ \frac{-(\beta - \beta_0)^2}{2} \right\} d\beta$$

$$H_r(\omega, \beta_0) = d^2 |\Gamma_s|^2 S_n(\omega) \frac{C(\sigma)}{\sqrt{2\pi} \sigma} \times$$

$$\int_{\beta_0 - \pi/2}^{\beta_0 + \pi/2} \{1 + \cos(T \cos \beta)\} \{1 - \cos(T \sin \beta)\} \exp\left\{ \frac{-(\beta - \beta_0)^2}{2\sigma^2} \right\} d\beta \quad \text{III-18}$$

Setting $I_r(\omega, \beta_0)$ equal to the integral in Equation III-18 and expanding the integrand yields

$$I_r(\omega, \beta_0) = \int_{\beta_0 - \pi/2}^{\beta_0 + \pi/2} \{1 + \cos(T \cos \beta) - \cos(T \sin \beta) - \\ \cos(T \cos \beta) \cos(T \sin \beta)\} \exp\left\{ \frac{-(\beta - \beta_0)^2}{2\sigma^2} \right\} d\beta \quad \text{III-19}$$

$$\text{where } H_r(\omega, \beta_0) = d^2 |\Gamma_s|^2 S_n(\omega) \frac{C(\sigma)}{\sqrt{2\pi} \sigma} I_r(\omega, \beta_0) .$$

Again a closed form solution does not exist and the same numerical integration technique was applied (see Section IV) .

3. Square platform, pitch moment. As mentioned previously, for a square TLP the pitch moment is simply rotated 90 degrees from the roll moment. Thus

$$H_p(\omega, \beta_0) = d^2 |\Gamma_s|^2 S_n(\omega) \frac{C(\sigma)}{\sqrt{2\pi} \sigma} I_p(\omega, \beta_0)$$

where $I_p(\omega, \beta_0) = I_r(\omega, \beta_0 + \pi/2)$.

4. Normalization. In order to compare the effect of the wave spreading for different configurations a method of normalization was developed. The normalization factor was taken to be the force or moment frequency spectrum resulting from waves of equal amplitude from all directions in one half of the plane. Thus $S_n(\omega, \beta, \beta_0)$ equals $(1/\pi) S_n(\omega)$ for $(\beta_0 - \pi/2) < \beta < (\beta_0 + \pi/2)$ and zero elsewhere. The normalization frequency spectrum becomes

$$H_0(\omega, \beta_0) = \int_{\beta_0 - \pi/2}^{\beta_0 + \pi/2} |\Gamma_t(\omega, \beta)|^2 (1/\pi) S_n(\omega) d\beta.$$

Because of the symmetry of a square platform and the uniformity of this spreading it makes no difference where the center of the spectrum is. For convenience β_0 was taken to be zero and thus the normalization spectrum becomes

$$H_0(\omega) = \frac{1}{\pi} S_n(\omega) \int_{-\pi/2}^{\pi/2} |\Gamma_t(\pi, \beta)|^2 d\beta \quad \text{III-20}$$

which is simply the mean square value of Γ_t times $S_n(\omega)$.

For heave and roll they are as follows

$$H_{0h}(\omega) = \frac{4}{\pi} S_n(\omega) |\Gamma_s|^2 \int_{-\pi/2}^{\pi/2} \{1 + \cos(T \cos \beta)\} \{1 + \cos(T \sin \beta)\} d\beta \quad \text{III-21}$$

$$H_{0r}(\omega) = \frac{4}{\pi} S_n(\omega) |\Gamma_s|^2 \int_{-\pi/2}^{\pi/2} \{1 + \cos(T \cos \beta)\} \{1 - \cos(T \sin \beta)\} d\beta \quad \text{III-22}$$

The normalized spectrum for heave is thus

$$HN_h(\omega, \beta_0) = \frac{H_h(\omega, \beta_0)}{H_{0h}(\omega)} \quad \text{III-23}$$

Expanding the numerator and denominator and cancelling the common terms $S_n(\omega)$ and $|\Gamma_s|^2$ this leaves

$$HN_h(\omega, \beta_0) = \frac{I1_h(\omega, \beta_0)}{I3_h(\omega)} \quad \text{III-24}$$

where

$$\begin{aligned} I1_h(\omega, \beta_0) &= \frac{H_h(\omega, \beta_0)}{S_n(\omega) |\Gamma_s|^2} \\ &= \frac{4}{\sqrt{2\pi}} \frac{C(\sigma)}{\sigma} \int_{\beta_0 - \pi/2}^{\beta_0 + \pi/2} \{1 + \cos(T \cos \beta)\} \times \\ &\quad \{1 + \cos(T \sin \beta)\} \exp\left\{-\frac{(\beta - \beta_0)^2}{2\sigma^2}\right\} d\beta \end{aligned}$$

$$\begin{aligned} I3_h(\omega) &= \frac{H_{0h}(\omega)}{S_n(\omega) |\Gamma_s|^2} \\ &= \left(\frac{4}{\pi}\right) \int_{-\pi/2}^{\pi/2} \{1 + \cos(T \cos \beta)\} \{1 + \cos(T \sin \beta)\} d\beta \end{aligned}$$

Similarly for roll

$$HN_r(\omega, \beta_0) = \frac{H_r(\omega, \beta_0)}{H_{0r}(\omega)} = \frac{I1_r(\omega, \beta_0)}{I3_r(\omega)}$$

where

$$\begin{aligned} I1_r(\omega, \beta_0) &= \frac{H_r(\omega, \beta_0)}{S_n(\omega) |\Gamma_s|^2} \\ &= \frac{d^2}{\sqrt{2\pi}} \frac{C(\sigma)}{\sigma} \int_{\beta_0 - \pi/2}^{\beta_0 + \pi/2} \{1 + \cos(T \cos \beta)\} \times \\ &\quad \{1 - \cos(T \sin \beta)\} \exp\left\{-\frac{(\beta - \beta_0)^2}{2\sigma^2}\right\} d\beta \end{aligned}$$

$$\begin{aligned} I3_r(\omega) &= \frac{H_{0r}(\omega)}{S_n(\omega) |\Gamma_s|^2} \\ &= \frac{d^2}{\pi} \int_{-\pi/2}^{\pi/2} \{1 + \cos(T \cos \beta)\} \{1 - \cos(T \sin \beta)\} d\beta . \end{aligned}$$

IV. Numerical Prediction of Exciting Forces

A. Discussion.

Because of the complicated forms of the integrands of Equations III-17 and III-19 no closed form solutions to the integrals were found to exist. Numerical methods were employed to determine the variation of resulting forces caused by the variation in input parameters. Appendices I and II provide program listings and an explanation for their use.

B. Assumed values.

In order to use numerical methods of calculation values must be assumed for the relevant parameters. In this thesis the initial values assumed come from two Amoco papers published in the "Journal of Petroleum Technology." (See Reference 1.) These papers discuss a proposed vertically moored platform (VMP) which is identical to the concept of a TLP. Amoco's VMP is proposed to have leg spacings of 160 feet and is estimated to have heave, pitch, and roll natural periods of approximately two seconds. Because of the popularity of the cosine squared wave spectrum a comparable standard deviation of 0.65

radians was chosen.

The parameter of interest in all of the following analyses is H_N , the ratio of the magnitude of the transfer function for Gaussian wave spreading to the magnitude of the transfer function for uniform wave spreading.

When the Amoco TLP was analyzed in normally distributed waves with a 0.65 standard deviation the results were somewhat surprising. The variation in H_N from unity in heave was less than one percent for all values of wave spectrum incidence, θ , (see Table IV-1). A much greater variation of H_N for roll was expected but H_N still remained within ten percent of unity (see Table IV-2). Clearly for this case an initial assumption of uniform wave spreading and the resulting simplifications in calculation of the force spectrum will provide very useful first pass information to the designer.

However the Amoco proposal is by no means the only viable configuration for a TLP. One must consider the variation in H_N as other parameters vary.

C. Variation in leg spacing.

The most obvious variation in a platform is the spacing between the legs. With the 160 feet of the Amoco platform

as a reference, leg spacings ranging from 100 to 250 feet were considered. Analysis results for heave are presented in Table IV-3 and for roll (and hence pitch) in Table IV-4.

For all of these configurations HN for heave is still within one percent of unity. Roll suffers somewhat but the calculated HN stays well within 20% of one. For initial design work this accuracy is sufficient and the assumption of uniform spreading would be justifiable.

D. Variation in period.

Because the wave spectrum is continuous in frequency waves of all periods will be incident upon the structure. However, the period of paramount concern is the natural period of the structure. This varies from structure to structure and is somewhat controllable. Again taking the Amoco value, two seconds, as a reference, periods from one to three seconds were considered. The leg spacing was assumed to be 160 feet and the standard deviation 0.65 radians. Analysis results for heave are tabulated in Table IV-5. The results for roll however vary enough to be visible on a polar plot of HN vs. β_0 , the center of the wave spectrum, and are shown in Figure IV-6. When possible a plot has been preferred to a table because of

the greater amount of information compactly presented.

For heave the variation in HN remains at about one percent reaching a high of two percent for a three second period. For roll HN shows marked fluctuation but again stays within twenty percent of unity. While the natural period has significant implications with respect to the periods of significant wave energy it does not appear to significantly alter the modal force transfer functions as long as some directional spreading is present.

E. Variation in standard deviation

The final parameter to vary is the standard deviation. The standard deviation for uniform wave spreading is infinite while that for unidirectional waves is zero. However, as shown in Section III-B standard deviations above two radians approximate the condition of uniform wave spreading. Therefore almost all of the effect of varying standard deviation occurs between zero and two. One would thus expect a significant change in HN as standard deviation changes, particularly for small values.

This expectation is correct. Standard deviation was varied from 0.125 to 2 radians for both heave and roll (D = 160 feet, Per = 2.0 seconds). The results are plotted

in Figures IV-7 and IV-8 for heave and roll respectively.

Consider heave (Figure IV-7). For standard deviations of 1.0 or 2.0 radians HN stays within one percent of unity. When $\sigma = 0.5$ the variation becomes five percent. For $\sigma = 0.25$ it exceeds twenty percent and when the standard deviation is 0.125 radians even the pattern of the curve changes. For roll (Figure IV-8) the results are similar, although somewhat more pronounced.

However, if one can allow a 15% error in an initial design approximation then the uniform wave spreading assumption is valid for wave directional spectra with standard deviations greater than approximately 0.5 radian. Note that cosine squared spreading is included in this category.

F. Summary

Numerous other cases were considered, simultaneously varying leg spacing, period, and standard deviation. In all cases where $\sigma > 0.5$ the resulting normalized amplitude-platform force transfer function had a magnitude within 20% of unity. Thus for waves with any reasonable amount of spreading sufficient accuracy for initial design calculations can be obtained by using the mean square value of $\Gamma(\omega, \beta)$. This result allows for a simpler initial calculation of

platform response to random waves in the manner of Vandiver.⁴ For situations when $\sigma < 0.5$ or when more accuracy is required Vandiver's method can still be employed using the computer programs of this thesis to determine HN (Vandiver's C1).

**SQUARE TENSION LEG PLATFORM, HEAVE EXCITATION
WITH GAUSSIAN WAVE DISTRIBUTION**

LEG SPACING = 160 feet
 PERIOD = 2.0 seconds
 STANDARD DEVIATION = 0.65 radians

Correction factor due to loss of tails = 1.016
 Factor due to uniform spreading (I3) = 3.94

β_0	I1	$HN_h = I1/I3$
0	3.90	0.990
5	3.91	0.992
10	3.92	0.994
15	3.93	0.997
20	3.94	1.000
25	3.95	1.002
30	3.96	1.004
35	3.96	1.006
40	3.96	1.006
45	3.97	1.007

**Table IV-1 Normalized Platform Heave Exciting Force
(D=160 feet, Per=2.0 sec, $\sigma=0.65$ rad.)**

SQUARE TENSION LEG PLATFORM, ROLL EXCITATION

WITH GAUSSIAN WAVE DISTRIBUTION

LEG SPACING = 160 feet
 PERIOD = 2.0 seconds
 STANDARD DEVIATION = 0.65 radians

Correction factor due to loss of tails = 1.016
 Factor due to uniform spreading (I3) = 0.235 E+05

θ	I1	$HN_F = I1/I3$
0	0.216 E+05	0.919
5	0.216 E+05	0.920
10	0.217 E+05	0.922
15	0.218 E+05	0.925
20	0.219 E+05	0.933
25	0.222 E+05	0.943
30	0.224 E+05	0.954
35	0.227 E+05	0.967
40	0.231 E+05	0.981
45	0.234 E+05	0.996
50	0.238 E+05	1.011
55	0.241 E+05	1.026
60	0.244 E+05	1.040
65	0.248 E+05	1.053
70	0.251 E+05	1.068
75	0.254 E+05	1.079
80	0.255 E+05	1.086
85	0.256 E+05	1.090
90	0.257 E+05	1.092

Table IV-2 Normalized Platform Roll Exciting Moment

(D=160 feet, Per=2.0 sec, σ =0.65 rad.)

**SQUARE TENSION LEG PLATFORM, HEAVE EXCITATION
WITH GAUSSIAN WAVE DISTRIBUTION**

PERIOD = 2.0 seconds
STANDARD DEVIATION = 0.65 radians

CORRECTION FACTOR DUE TO LOSS OF TAILS = 1.016

LEG SPACING (feet)	\overline{HN}_h (min.)	\overline{HN}_h (max.)
100	0.997	1.003
150	0.998	1.003
200	0.994	1.006
250	0.995	1.004

**Table IV-3 Normalized Platform Heave Exciting Force
(Various leg spacings, Per=2.0 sec, $\sigma=0.65$ rad.)**

SQUARE TENSION LEG PLATFORM, ROLL EXCITATION
WITH GAUSSIAN WAVE DISTRIBUTION

PERIOD = 2.0 seconds
 STANDARD DEVIATION = 0.65 radians

CORRECTION FACTOR DUE TO LOSS OF TAILS = 1.016

LEG SPACING (feet)	HN_r (min.)	HN_r (max.)
100	0.978	1.027
150	0.933	1.067
200	0.882	1.114
250	0.846	1.160

Table IV-4 Normalized Platform Roll Exciting Moment
(Various leg spacings, Per=2.0 sec, $\sigma=0.65$ rad.)

**SQUARE TENSION LEG PLATFORM, HEAVE EXCITATION
WITH GAUSSIAN WAVE DISTRIBUTION**

LEG SPACING = 160 feet
STANDARD DEVIATION = 0.65 radians

CORRECTION FACTOR DUE TO LOSS OF TAILS = 1.016

PERIOD (seconds)	HN_h (min.)	HN_h (max.)
1.0	0.997	1.001
1.5	0.996	1.005
2.0	0.990	1.007
2.5	0.994	1.004
3.0	0.980	1.024

**Table IV-5 Normalized Platform Heave Exciting Force
(D=160, Various periods, $\sigma=0.65$ rad.)**

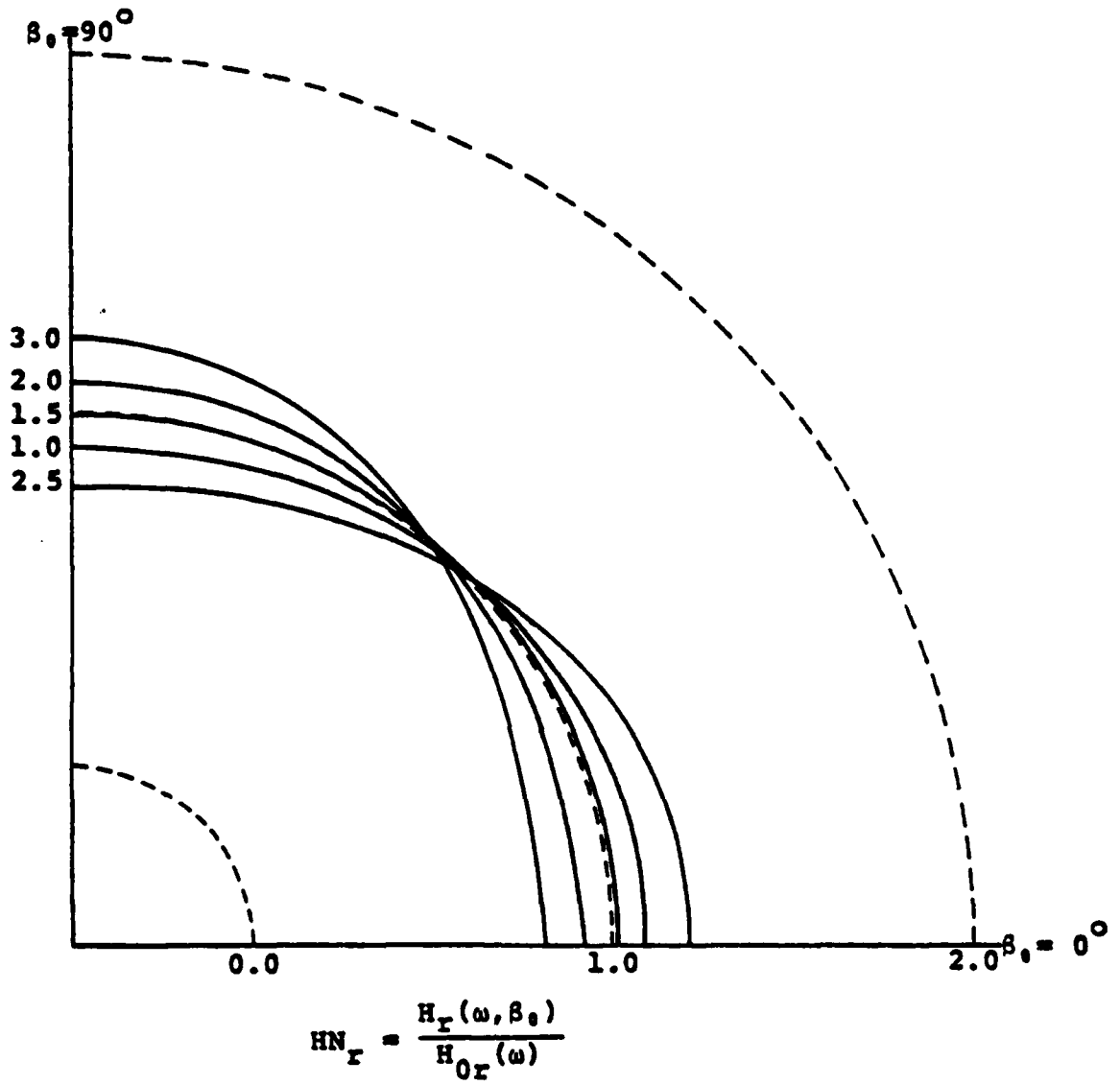

Figure IV-6 Normalized Platform Roll Exciting Moment
 (D=160, various periods, $\sigma=0.65$ rad.)

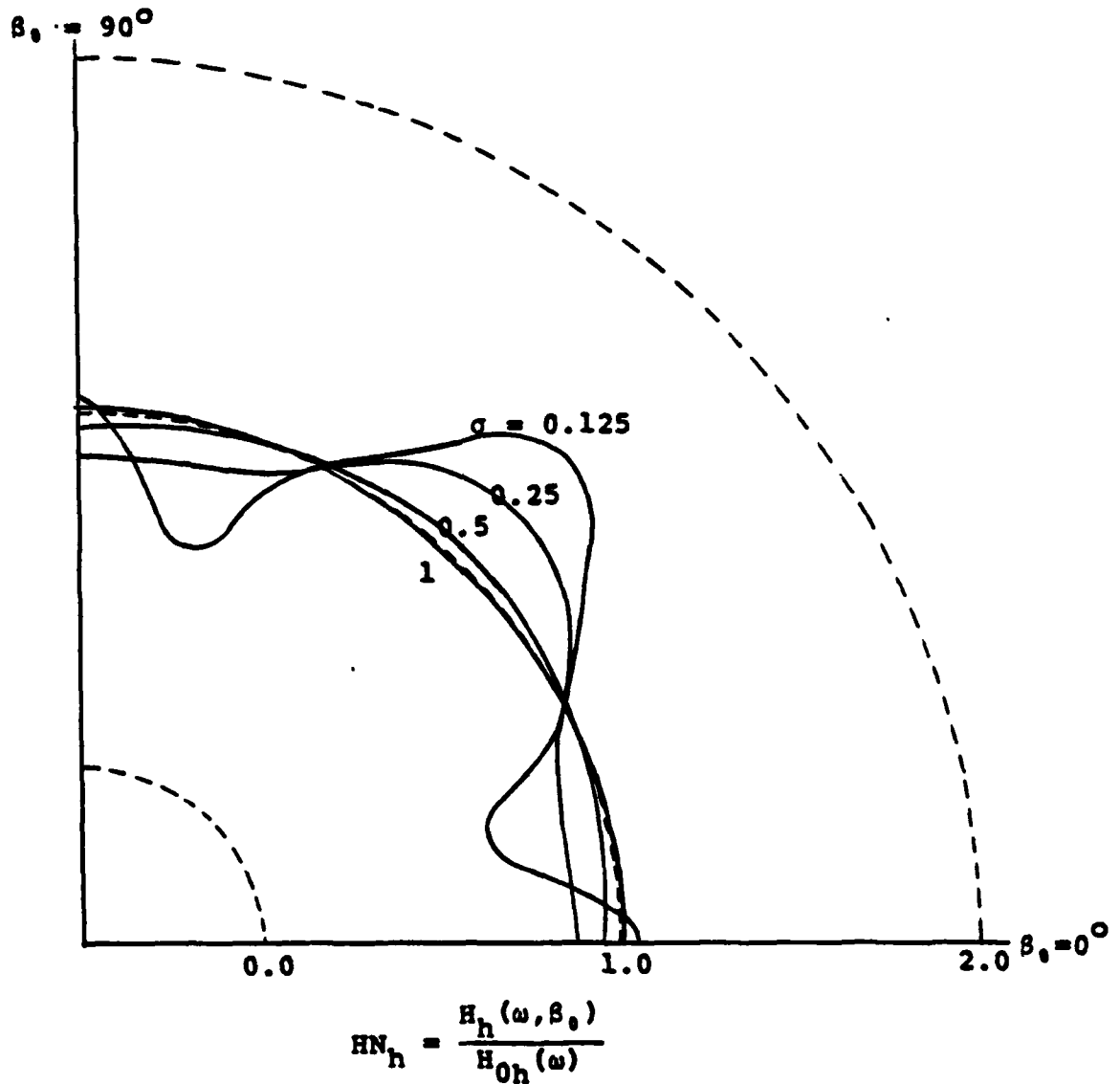

Figure IV-7 Normalized Platform Heave Exciting Force
(D=160, Per = 2.0 sec, various σ)

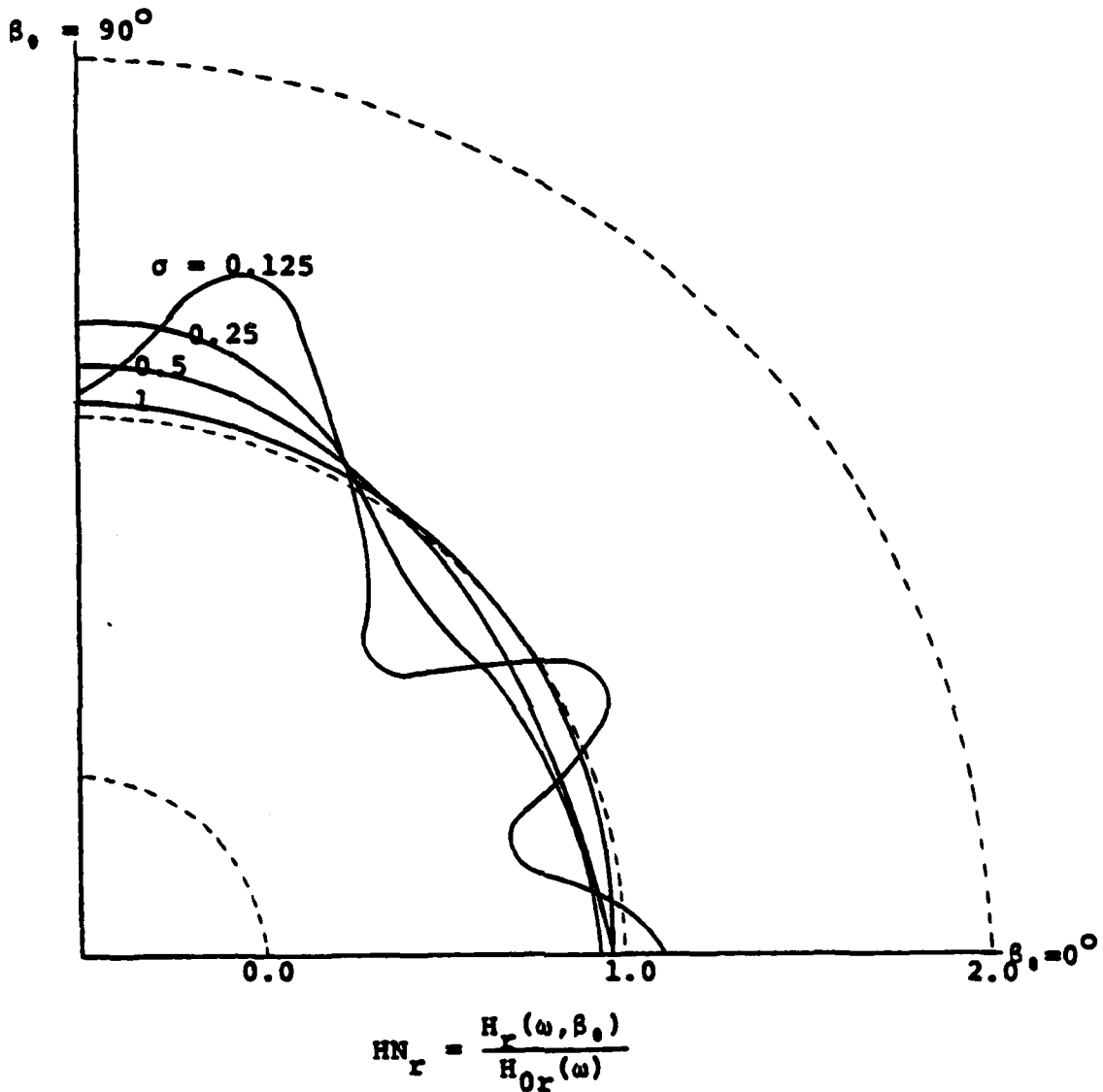

Figure IV-8 Normalized Platform Roll Exciting Moment
 (D=160, Per = 2.0 sec, various σ)

V. Suggestions for Experimental Verification

A. Single leg.

Because the results of the computer program provide a transfer function between forces on a single leg to platform forces and moments, the single leg forces must be obtained. This can be done theoretically or experimentally. This report will deal with experimental determination.

The single leg is assumed to be of circular cross section. Thus there is no angular dependence and testing can be performed in a ship model towing tank with a wave generator. In the proposed test the single leg model will be held rigid with load cells measuring the forces as a result of incident waves. These forces will be normalized to forces due to scaled unit amplitude waves using a linear assumption for the force to wave amplitude relation. By performing this test with a variety of wave frequencies a plot of $\Gamma_g(\omega)$ can be obtained. From this the computer will predict platform heave force and roll moment transfer functions.

B. Square TLP.

To completely test the results of this study would require the ability to generate a directional wave spectrum.

This ability is not available. However, the total transfer function, $\Gamma_t(\omega, \beta)$, can be experimentally verified for heave, pitch, and roll.

Once the results for a single leg are obtained a similar experiment with the total platform can be performed. The model should be held rigid with load cells measuring forces in all six degrees of freedom. The direction of wave incidence can be varied by turning the model.

This experiment will generate a family of curves of $\Gamma_t(\omega, \beta)$, one curve for heave and one for roll for each angle of incidence β . These curves can then be compared to those predicted using the measured forces for $\Gamma_s(\omega)$ and the heave and roll algorithms developed in this paper, Equations III-7 and III-10.

VI. Conclusions

A. Assumptions and approximations.

1. Linearity. The forces computed in this paper are those exerted by waves on a motionless structure. The forces are assumed to be linearly related to wave amplitude. Furthermore the forces exerted on a motionless structure can only be useful in predicting dynamic response if the equations of motion are linearized. For a TLP the equations of motion will be linear for low to moderate sea states. This is due to the large dimensions of the major members and to the relatively small response amplitudes. Damping terms for the TLP may also be linearized because the damping ratios are expected to be small in heave, pitch, and roll.

2. Effects of cross members. The model of a TLP used to derive the transfer functions had four legs acted upon by wave forces, and nothing else. Real TLP's must have cross members between the floatation legs to provide structural support. These would also be subject to wave forces.

The diameter of a cross member will be much smaller than that of the leg. In the Amoco platform referred to in Reference 1 the cross members have an outer diameter of 5.5 feet

while the floatation leg's diameter is 30 feet near the surface where the large wave forces are. This is a factor of about 5 $\frac{1}{4}$ difference. The displaced volume is proportional to the cross sectional areas which are almost a factor of 30 different. In addition the support members are mostly near the bottom of the legs, away from the largest wave forces. The parts that are shallow are close to the legs and would react in phase with them. Thus the effect of the waves on the cross members can be assumed to be negligible with respect to the effect on the legs.

3. Wave disturbances of the legs. Another aspect not considered in this model is the effect of one leg upon the waves incident upon the others. In the Amoco example the outer edges of the legs at the water surface are 130 feet apart which is only about four times their 30 foot diameters. There could be some shielding or reflecting effects present, causing the results of this study to be in error. As the ratio of leg spacing to leg diameter increases these errors will decrease.

The primary purpose of this thesis was to evaluate the influence of wave spreading on the heave, pitch, and roll force spectra. The most important geometric effect is the relative phases of forces exerted on the legs. In cases

that the wave spreading is shown to be sufficient to average out the relative phase effects, then it can certainly be argued that interaction effects between legs would also be suppressed.

B. Utility of results.

1. Initial design approximation. For wave directional spreading with a standard deviation of greater than 0.5 radians the heave force or roll or pitch moment imposed upon a TLP can be approximated within 20% to be that imposed by uniformly spread seas. By incorporating this into the method used by Vandiver⁴ an initial estimate of the response of a TLP can be obtained which would be applicable in preliminary design.

2. More accurate approximation. If the standard deviation of the wave spectrum is less than 0.5 radian or if an answer with more than 20% accuracy is required then the computer program outlined in Appendices I and II can be used to determine HN (Vandiver's C1). This can then be incorporated into the calculations of the modal response of the structure.

3. Variation to fit other structures. Results for other square TLP's can easily be obtained simply by changing

the values assigned for the leg spacing and the period of interest. If the structure of interest is not square the same concept can be applied by changing the program definitions of the transfer functions. In this manner results can be obtained for any shape of TLP (square, triangular, rectangular, etc.) with any leg spacing and any natural period.

4. Wave directional spectrum variation. The greatest advantage of modeling the wave directional spectrum as a Gaussian process is the continuous variation in spreading it provides. The standard deviation of the wave spectrum at a proposed location for a TLP could be measured under various conditions, noting that the periods of the significant wave energy would also change. This information, standard deviation and period, could then be input to this program to estimate platform forces and moments under those conditions. The final information of forces, moments, and responses would then be applied to sizing the tension members for adequate tensile and fatigue strength and to ensure the platform motions do not cause equipment malfunctions or personnel discomfort.

NOMENCLATURE

a	distance from center of TLP to center of any leg
C	constant to normalize the area of the wave directional spectrum
d	leg spacing of TLP
g	acceleration of gravity
h	as a subscript, denotes heave
H_x	frequency spectrum of the total force or moment on the TLP due to wave spreading
H_{0x}	frequency spectrum of the total force or moment on the TLP due to uniformly distributed waves
HN_x	normalized frequency spectrum of the total force or moment on the TLP
I_x	integral portion of H_x dependent on wave spreading
I_{1x}	numerator of HN_x , dependent on platform geometry and wave spreading
I_{3x}	denominator of HN_x , dependent only on platform geometry
k	wavenumber
l_i	distance from center of TLP to projection of leg i on the direction of wave propagation
p	as a subscript, denotes pitch
r	as a subscript, denotes roll
R	ratio of magnitude squared of platform Γ to magnitude squared of single leg Γ
s	as a subscript, denotes single leg
S_n	wave spectrum

t as a subscript, denotes total platform
 T non-dimensional quantity determined by leg spacing and wave frequency
 β angle of wave incidence measured from roll axis
 β_0 angle of incidence of center of wave spectrum
 Γ_x transfer function from incident wave amplitude to force (or moment) exerted upon the structure
 δ_{mn} Dirac delta function
 λ wavelength of incident waves
 σ standard deviation of wave directional spectrum
 Σ summation
 ϕ_i phase shift of the wave incident on leg i as compared to the wave at the center of the TLP
 ϕ normal distribution function
 ω radian frequency of incident waves

REFERENCES

1. Berman, M. et al; Beynet, P. et al: "The Vertically Moored Platform for Deepwater Drilling and Production" and "Motion, Fatigue, and the Reliability Characteristics of a Vertically Moored Platform," Journal of Petroleum Technology, March, 1979.
2. Crandall, S. and Mark, W.: Random Vibration, Academic Press, New York (1973).
3. Cohen, A. et al; Numerical Analysis, McGraw Hill Book Company (U.K.) Limited, Maidenhead, Berkshire, England (1973).
4. Vandiver, J. K.: "Prediction of the Damping Controlled Response of Offshore Structures to Random Excitation," OTC 3515 (1979).

Appendix I. Computer Program Listing

A. Discussion.

Because of the complicated forms of the integrands of Equations III-17 and III-19 no closed form solution to the integral was found to exist. Yet the trigonometric functions with trigonometric arguments caused such rapid oscillations of the integrand that most numerical methods failed to converge. The method found to be the most useful was Gauss-Legendre quadrature (see Appendix III). A quadrature of fifth order was found to give sufficient numerical accuracy and is contained in the subroutine GAULEG.

Because the wave directional spectrum was only non-zero between plus and minus $\pi/2$ radians a correction factor was necessary to ensure its area was unity. This correction was accomplished by an eighth order polynomial approximation to the area under the normal curve. This approximation was developed by the author and is contained in the subroutine ERF.

Because of peculiarities in the computer system available the platform transfer functions are entered as function subprograms HEAV and FHEAVE for heave, and ROLL

and FROLL for roll, the former of each pair being the transfer function with uniform wave spreading.

The program is written in FORTRAN-IV language and has numerous comment statements to aid in its understanding.

B. Program listing.

A listing of the programs for heave and roll, with associated subprograms, follows.

```

000          TENSION LEG PLATFORM
001          HEAVE
002          EXTERNAL HEAV, PHEAV
003 C SET STANDARD DEVIATION (SD), LEG SPACING (D), AND PERIOD (PER)
004          D=150.
005          SD=0.55
006          PER=2.
007 C CALCULATE VARIANCE AND T
008          VAR=SD**2
009          T=1.226039*D/PER**2
010          WRITE (5,5)
011          5   FORMAT ('1',T10,'SQUARE TENSION LEG PLATFORM',HEAV EXCITATION')
012          WRITE (5,10)
013          10  FORMAT (' ',F15,'GAUSSIAN WAVE DISTRIBUTION'//)
014          WRITE (5,15) D
015          15  FORMAT (' ',F15,'LEG SPACING=',T40,F5.0,' FEET')
016          WRITE (5,20) PER
017          20  FORMAT (' ',F15,'PERIOD=',T40,F5.1,' SECONDS')
018          WRITE (6,25) SD
019          25  FORMAT (' ',F15,'STANDARD DEVIATION=',T30,F5.2,' RADIANS'//)
020
021          CORRECTION FACTOR FOR LOSS OF TAILS OF GAUSSIAN
022          WIDTH=1.577796/SD
023          CALL ERFC (WIDTH,PHI)
024          C=1./(2.*PHI-1.)
025          WRITE (5,30) C
026          30  FORMAT (' ',F15,'CORRECTION FACTOR DUE TO LOSS OF TAILS=',F6.3)
027          FACTOR DUE TO UNIFORM SPREADING
028
029          YL=-1.570796
030          XJ= 1.570796
031          RC=0.
032          CALL SABLES (YL,XJ,HEAV,R,IP,90,VAR,T)
033          RI3=R
034          WRITE (5,35) RI3
035          35  FORMAT (' ',F15,'FACTOR DUE TO UNIFORM SPREADING (I3)=',E11.4)
036          WRITE (5,40) IP
037          40  FORMAT (' ',F20,'(SERVO CONDITION=',I3,')//)
038          WRITE (5,45)
039          45  FORMAT (' ',F23,'T1',T45,'RN=I1/I3',T52,'ERROR?//)
040
041 C VARY DIRECTION OF CENTER OF WAVE SPECTRUM
042          BODE2=0.
043          100 BODE2=BODE2*1.745323E-2
044          XL1=XL+BODE2
045          YJ1=YJ+BODE2
046          CALL SABLES (XL1,XJ1,PHEAV,Y,ERR,90,VAR,T)
047          RT1=Y*C/SD
048          H1=RT1/RI3
049          WRITE (6,50) BODE2,RT1,PW,TEP
050          50  FORMAT (' ',F5.1,T17,E11.4,T42,F10.3,T52,I3)
051          BODE2=BODE2+5.
052          IF (BODE2.LE. 45.) GO TO 100
053          STOP
054          END

```

```

C          TENSION LEG PLATFORM
C          ROLL
C          EXTERNAL ROLL, FROLL
C SET STANDARD DEVIATION (SD), LEG SPACING (D), AND PERIOD (PER)
D=160.
SD=0.65
PER=2.
C CALCULATE VARIANCE AND T
20C     VAP=SD**2
300     T=1.22603R*D/PER**2
        WRITE (6,5)
5       FORMAT ('* ',T10,'*SQUARE TENSION LEG PLATFORM, ROLL EXCITATION*')
        WRITE (6,10)
10      FORMAT ('* ',T15,'*GAUSSIAN WAVE DISTRIBUTION*//')
        WRITE (6,15) D
15      FORMAT ('* ',T15,'*LEG SPACING=*',T40,F5.0,'* FEET*')
        WRITE (6,20) PER
20      FORMAT ('* ',T15,'*PERIOD=*',T40,F5.1,'* SECONDS*')
        WRITE (6,25) SD
25      FORMAT ('* ',T15,'*STANDARD DEVIATION=*',T39,F6.2,'* RADIANS*//')
C
C          CORRECTION FACTOR FOR LOSS OF TAILS OF GAUSSIAN
WIDTH=1.570796/SD
CALL ERF (WIDTH,PHI)
C=1./(2.*PHI-1.)
WRITE (6,30) C
30 FORMAT ('* ',T15,'*CORRECTION FACTOR DUE TO LOSS OF TAILS=*',F6.3)
C FACTOR DUE TO UNIFORM SPREADING
C
        XL=-1.570796
        XU= 1.570796
        B=0.
        call gaulen (xl,xu,roll,rfrr,R0,VAR,T)
        R13=R*D**2
        WRITE (6,35) R13
35      FORMAT ('* ',T15,'*FACTOR DUE TO UNIFORM SPREADING (I3)=*',E11.4)
        WRITE (6,40) IR
40      FORMAT ('* ',T20,'*(ERPOR CONDITION=*',I3//)
        WRITE (6,45)
45      FORMAT ('* ',T23,'*I1*',T45,'*MN=I1/I3*',T62,'*ERROR?//')
C
C VARY DIRECTION OF CENTER OF WAVE SPECTRUM
BODEG=0.
100     R0=R0DEG+1.745329E-2
        XL1=XL+B0
        XU1=XU+B0
        call gaulen (xl1,xu1,froll,y,icr,R0,VAR,T)
        R11=Y*D**2*C/SD
        MN=R11/R13
        WRITE (6,50) B0DEG,R11,MN,IER
50      FORMAT ('* ',F5.1,T17,E11.4,T42,F10.0,T62,I3)
        B0DEG=B0DEG+.1
        IF (B0DEG .LE. 90.) GO TO 100
        STCP
        END

```

```

SUBROUTINE GAULEG (XL,XU,PCT,Y,IER,RO,VAP,T)
THIS IS A FIFTH ORDER GAUSS-LEGENDRE QUADRATURE
C
I=0
H=(XU-XL)/10.
A1= 0.2349240
A2=0.4786287
A3=0.5688889
C
X1=0.9061798
X2=0.5384693
SU4=0.
C
1  W=.5*H
   Y2=.5*H
   A=XL+W2
   Y1=X1*H2
   Y2=X2*H2
   I=I+1
   SU41=SU4
   SU4=0.
3  B1=1+Y1
   B2=1-Y1
   B3=1+Y2
   B4=1-Y2
   SU4=SU4+A1*(FCT(B1,RO,VAP,T)+FCT(B2,RO,VAP,T))+A2*
1  (FCT(B3,RO,VAP,T)+FCT(B4,RO,VAP,T))+A3*FCT(1,RO,VAP,T)
C
A=A+H
IF (XU-A) 0,0,3
4  SU4=H2*SU4
IF (SU4 .EQ. 0.) GO TO 6
ERR=ABS((SU4-SU41)/SU4)
C
IF (I.GT.10) GO TO 6
IF (ERR-.01) 5,5,1
C
5  IER=0
   Y=SU4
   RETURN
6  IER=1
   Y=SU4
   RETURN
END

```

```

SUBROUTINE EBF (Y, PHI)
C EIGHTH ORDER POLYNOMIAL APPROXIMATION OF THE AREA UNDER
C THE STANDARD NORMAL CURVE
C DIMENSION AUX(8)
I=0
C ALLOW FOR NEGATIVE VALUES OF Y
IF (Y) 1, 3, 2
1 I=1
Y=-Y
2 IF (Y.LT. 3.9) GO TO 3
PHI=1.
GO TO 20
3 Y=1.
PHI= .5
AUX(1)= 3.997013E-1
AUX(2)=-1.29396E-4
AUX(3)=-6.161270E-2
AUX(4)=-1.297045E-2
AUX(5)= 2.502698E-2
AUX(6)=-2.005365E-3
AUX(7)= 1.430251E-3
AUX(8)=-9.621522E-5
DO 10 I=1, 8
Y=Y*AUX(I)
10 PHI=PHI+Y*AUX(I)
20 IF (I.EQ. 1) PHI= 1.-PHI
RETURN
END

```

THIS PAGE IS BEST QUALITY PRACTICABLE
FROM COPY FURNISHED TO DDC

```

FUNCTION FHEAV(B,B0,VAR,T)
FHEAV=1.595769*(1.+COS(T*COS(B)))*(1.+COS(T*SIN(B)))*
1 EXP(-(B-B0)**2/(2.*VAR))
RETURN
END

```

```

function HEAV(b,B0,VAR,T)
HEAV=1.27324*(1.+COS(T*COS(B)))*(1.+COS(T*SIN(B)))
RETURN
END

```

```

FUNCTION FROLL(B,B0,VAR,T)
FROLL=.399942*(1.+COS(T*COS(B)))*(1.-COS(T*SIN(B)))*
1 EXP(-(B-B0)**2/(2.*VAR))
RETURN
END

```

```

FUNCTION ROLL(B,B0,VAR,T)
ROLL=.3193032*(1.+COS(T*COS(B)))*(1.-COS(T*SIN(B)))
RETURN
END

```

THIS PAGE IS UNCLASSIFIED
 DATE 09/15/2011 BY 60322 UCBAW

Appendix II. Directions For Use of Program

A. Discussion.

This program was intentionally designed to remain as much as possible in discrete sections, each performing a specific purpose. In this manner the program can be more easily understood by others and converted to use for many different sizes and types of structures.

An error flag has been added to the subprogram GAULEG. If GAULEG is unable in a reasonable time to get consecutive iterations to agree within one percent it flags this fact to the user by indicating an error condition of one. If the error condition is zero then GAULAG has gotten the same answer (within one percent) for two iterations with the second iteration having twice as many increments as the first.

B. Numerical parameters.

To make it easier to understand the program flow the leg spacing (D), standard deviation (SD), and period (PER) are simply assigned values in FORTRAN statements. They could just as easily be read from data cards, input from an interactive terminal, or varied in do-loops, whichever is most

convenient for the user on the available system.

To adopt the program to a square TLP of interest one must simply replace the assignment statements for leg spacing and for the period of interest. If many periods are important then a do-loop for period should be used returning to statement 300 to ensure the value of T is updated. If a do-loop is used to vary standard deviation it must return to statement 200 to revise the value of the variance.

The center of the wave spectrum (β_0) was varied in an implied do-loop with statement 100 because one is normally interested in the response to waves coming from all directions. Because of the symmetry properties of a square TLP the angle must only be varied over 45 degrees for heave and 90 degrees for roll.

C. Conversion to other types of platforms.

The information concerning the platform geometry is contained in the platform transfer functions. In the computer program the definition of the functions in the function subprograms (ROLL, FROLL, HEAV, and FHEAV) entirely defines the structure. Note that a factor of d^2 was left in the main program rather than ROLL and FROLL since this factor will be present in moment transfer functions for any type of structure.

Thus to change this program to accomodate any shape TLP one must simply perform derivations similar to those in section III-A and use the results to replace the function definitions in the function subprograms.

D. Conversion to other wave spectra.

This program was explicitly written for a normally distributed wave directional spectrum because it is so easily varied. Simply by varying the standard deviation one can obtain as directional or uniform a spreading as desired. However, if another spectrum is preferred this program can be adapted.

The most obvious place to change is in the definition of FROLL and FHEAV. There the new spectrum would be substituted for the exponential term. In the main program the correction factor C/SD is applied after calling GAULEG using FROLL or FHEAV. This would be changed or eliminated. Since C, the factor for loss of tails, is no longer necessary the entire subroutine ERF could then be eliminated. New correction factors for the new spectrum would then be introduced.

It is also possible to normalize the transfer function using something other than uniform spreading. For this ROLL and HEAV only must be revised. If correction factors are

necessary they are best introduced in the main program after calling GAULEG for the integration.

Appendix III. Gauss-Legendre Quadrature

A. Legendre Polynomials

1. Definition. Define a set of polynomials $P_n(x)$ of degree n , where n is a non-negative integer, such that

$$\int_{-1}^1 P_m(x) P_n(x) dx = c_n \delta_{mn}$$

and $P_n(1) = 1$.

The first is an orthogonality condition and the second is necessary to fix c_n . Together they define a unique set of polynomials known as the Legendre polynomials, the first few of which are

$$P_0(x) = 1$$

$$P_1(x) = x$$

$$P_2(x) = \frac{1}{2}(3x^2 - 1)$$

$$P_3(x) = \frac{1}{2}(5x^3 - 3x).$$

In general they can be found by

$$P_n(x) = \frac{1}{2^n n!} \frac{d^n}{dx^n} (x^2 - 1)^n.$$

Note that $P_n(x)$ has n zeroes in the interval from minus one to one and is even for n even and odd for n odd.

2. Polynomial approximation. Any function piecewise continuous in the interval from minus one to one can be expanded in terms of an infinite series of Legendre polynomials. It can be approximated by a finite series of Legendre polynomials.

$$y(x) = \sum_{m=0}^{\infty} c_m P_m(x) = \sum_{m=0}^n c_m P_m(x)$$

B. Integral approximation

A simple means to evaluate the integral in the region minus one to one is as follows:

$$\int_{-1}^1 y(x) dx = \int_{-1}^1 \sum_{m=0}^{\infty} c_m P_m(x) dx$$

Multiply both sides by $1 = P_0(x)$:

$$\begin{aligned} \int_{-1}^1 y(x) dx &= \sum_{m=0}^{\infty} c_m \int_{-1}^1 P_m(x) P_0(x) dx \\ &= c_0 \int_{-1}^1 P_0(x) P_0(x) dx \end{aligned}$$

$$\int_{-1}^1 y(x) dx = 2 c_0$$

Thus the problem has now become one of finding c_0 , the coefficient of $P_0(x)$. One possible method will be shown using the example where $n=2$.

We desire to find coefficients and arguments such that

$$\int_{-1}^1 y(x) dx = 1 C_0 = A_0 y(x_0) + A_1 y(x_1) .$$

For any two points. x_0 and x_1 , we expect

$$C_0 P_0(x_0) + C_1 P_1(x_0) + C_2 P_2(x_0) = y(x_0)$$

$$C_0 P_0(x_1) + C_1 P_1(x_1) + C_2 P_2(x_1) = y(x_1)$$

Noting that $P_0(x) = 1$ and $P_1(x) = x$ and choosing x_0 and x_1 to be the zeroes of $P_2(x)$ this becomes

$$C_0 + C_1 x_0 = y(x_0)$$

$$C_0 + C_1 x_1 = y(x_1)$$

Where x_0 and x_1 are $\pm (1/\sqrt{3})$. By adding these two equations and noting that $x_0 = -x_1$ we have

$$2 C_0 = y(-1/\sqrt{3}) + y(1/\sqrt{3})$$

which is our desired answer.

To get a larger degree of accuracy a larger n is required. This method for determining $2 C_0$ remains effective. For the case of $n = 5$ the solution is (to seven significant digits)³

$$\int_{-1}^1 y(x) dx = (0.568 888 9) \{y(0)\} \\ + (0.478 628 7) \{y(.538 469 3) + y(-.538 469 3)\} \\ + (0.236 926 9) \{y(.906 179 8) + y(-.906 179 8)\} .$$

However, one is not always interested in the interval from minus one to one. A transform must then be used to transfer the region of interest to that interval. For additional accuracy without the need for a larger order quadrature the total interval can be divided into subintervals. Each subinterval can be transformed separately and the result summed. Thus each subinterval will be approximated by a fifth order polynomial. This is the method employed in the subroutine GAULEG.

