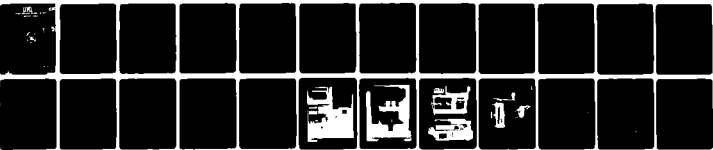


AD-A086 743

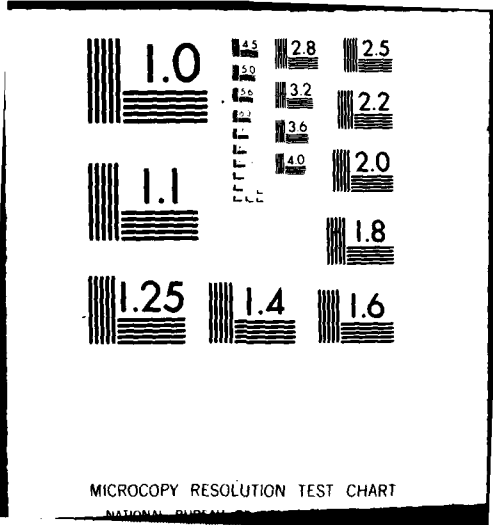
NAVY CLOTHING AND TEXTILE RESEARCH FACILITY NATICK MA F/G 6/17  
THERMAL INSULATION MATERIALS FOR DIVER'S UNDERWEAR GARMENT.(U)  
FEB 80 N F AUDET, G M ORNER, Z KUPFERMAN

UNCLASSIFIED

NL



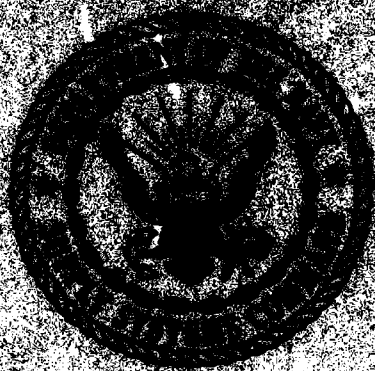
END  
DATE  
FILMED  
8-80  
DTIC



MICROCOPY RESOLUTION TEST CHART

NATIONAL BUREAU OF STANDARDS-1963-A

ADA 086743



SEARCHED  
SERIALIZED

ALL INFORMATION CONTAINED  
HEREIN IS UNCLASSIFIED

80 7 11

REPORT DOCUMENTATION PAGE		READ INSTRUCTIONS BEFORE COMPLETING FORM
1. REPORT NUMBER <b>14</b> <b>NCTRF-139-2-78</b>	2. GOVT ACCESSION NO. <b>AD-A086 743</b>	3. RECIPIENT'S CATALOG NUMBER <b>9</b>
4. TITLE (and Subtitle) <b>6</b> THERMAL INSULATION MATERIALS FOR DIVER'S UNDERWEAR GARMENT	5. TYPE OF REPORT & PERIOD COVERED Winter 1977-78 Spring 1978; Final Technical Report	
7. AUTHOR(s) <b>10</b> Norman F./Audet; George M./Orner and Zelig/Kupferman	8. CONTRACT OR GRANT NUMBER(s) 2-78 <b>Y1977-1978</b>	
9. PERFORMING ORGANIZATION NAME AND ADDRESS Navy Clothing and Textile Research Facility 21 Strathmore Road Natick, MA. 01760	10. PROGRAM ELEMENT, PROJECT, TASK AREA & WORK UNIT NUMBER <b>16</b> <b>11</b> 62755N-F51523-TP51523-003-57	
11. CONTROLLING OFFICE NAME AND ADDRESS Naval Coastal Systems Command Ocean Engineering Group (Code 712) Panama City, FL 32407	12. REPORT DATE <b>11</b> Feb 1978	
14. MONITORING AGENCY NAME & ADDRESS (if different from Controlling Office) Same as 11.	13. NUMBER OF PAGES 28 <b>231</b>	
	15. SECURITY CLASS. (of this report) Unclassified	
15a. DECLASSIFICATION/DOWNGRADING SCHEDULE		
16. DISTRIBUTION STATEMENT (of this Report) Approved for public release; distribution unlimited.		
17. DISTRIBUTION STATEMENT (of the abstract entered in Block 20, if different from Report) Same as 16.		
18. SUPPLEMENTARY NOTES Presented at the Annual Winter Meeting of the American Society of Mechanical Engineers (ASME), Ocean Engineering Division, held in San Francisco, CA, 12-15 Dec. 1978.		
19. KEY WORDS (Continue on reverse side if necessary and identify by block number) Diver's Dry-Suit Underwear; Thermal Insulation Materials; Foam Materials; Batt Materials; Thermal Insulation; Compressional Resistance; Air Permeability; Body Heat Loss; Cold-Water Environment.		
20. ABSTRACT (Continue on reverse side if necessary and identify by block number) The Navy Clothing and Textile Research Facility (NCTRF) conducted studies on commercially available foam and fibrous thermal insulating materials to determine those which would be effective in a diver's dry-suit underwear garment. (U) <i>over</i> (continued)		

368531

UNCLASSIFIED

SECURITY CLASSIFICATION OF THIS PAGE(When Data Entered)

An effective insulation had to allow the pressurized gaseous environment existing within the diver's dry suit to permeate the insulation, have good compressional resistance at hydrostatic pressures up to 2 psi (13.8 kPa), and provide an intrinsic thermal insulation value of 1.0 to 1.5 clo. (U)

To establish potential candidate materials, NCTRF studied a number of open-cell polyurethane foams having different pore sizes, densities, and thicknesses, and a low-density-polypropylene microfiber batt material for both thermal insulation and compressional resistance properties. (U)

→ Evaluations of candidate materials and comparisons with existing materials used in diver's dry-suit underwear indicated that a fine pore open cell foam and the polypropylene microfiber batt material having densities of approximately  $0.12 \text{ gr/cm}^3$  and  $0.05 \text{ gr/cm}^3$  and thermal insulation resistances of 1.8 and 2.11 clo/cm at 2 psi (13.8 kPa), respectively, would meet the thermal requirements for the underwear garment and would be superior to those presently being used. The foam compressed less than 30% at 2 psi (13.8 kPa). The fibrous material compressed 60% at 2 psi (13.8 kPa) but had such a high specific clo value uncompressed (2.27 clo/cm) that thermal resistance at 2 psi (13.8 kPa) was still estimated to be 2.11 clo/cm. (U)

UNCLASSIFIED

SECURITY CLASSIFICATION OF THIS PAGE(When Data Entered)

TABLE OF CONTENTS

	<u>Page</u>
List of Illustrations.....	iv
List of Tables.....	v
Introduction.....	1
Material Descriptions.....	1
"In Use" Types.....	1
Open-Cell Foam Types.....	2
Fibrous Batt Type.....	2
Thermal Insulation Tests.....	2
Compression Tests.....	5
Air Permeability.....	5
Material Weights.....	6
Results.....	6
Air Permeability.....	6
Compressional Resistance.....	8
Thermal Insulation Resistance.....	9
Discussion of Results.....	11
Conclusions.....	12
References.....	12
Appendix A. Illustrations.....	A-1

Accession For	
NTIS AD/AI	<input checked="" type="checkbox"/>
DOC TAB	<input type="checkbox"/>
Unannounced	<input type="checkbox"/>
Justification	
By _____	
Distribution/ _____	
Availability Codes	
Dist	Avail and/or special
A	

LIST OF ILLUSTRATIONS

<u>Figure</u>		<u>Page</u>
1	Circular Guarded Hot Plate Apparatus and Control and Measurement Instrumentation.....	A-2
2	Material Thermal Resistance Test Under Pressure Simulation of 0.44 psi.....	A-3
3	Test Setup for Compression Tests.....	A-4
4	Test Setup for Air Permeability Tests.....	A-5
5	Thickness Change VS Pressure for I and C Group Low Density Foams.....	A-6
6	Thickness Change VS Pressure for I and C Group 90 PPI Pore Size High Density Foams.....	A-7
7	Thickness Change VS Pressure for "IN USE" and Candidate Fibrous Batt and I Group Foam Materials.....	A-8
8	Specific Thermal Resistance VS Thickness for I and C Group Low Density Foams.....	A-9
9	Specific Thermal Resistance VS Air Permeability for I and C Group Low Density Foams.....	A-10
10	Specific Thermal Resistance VS Density for I and C Group 90 PPI Pore Size Foams.....	A-11
11	Comparison of Specific Thermal Resistance of "IN USE" and Candidate Fibrous Batt and I Group Foam Materials With No Pressure Loading.....	A-12
12	Intrinsic Thermal Resistance Change VS Pressure for "IN USE" and Candidate Fibrous Batt and I Group Foam Materials.....	A-13

LIST OF TABLES

<u>Table</u>		<u>Page</u>
1	Physical Characteristics of Materials Evaluated.....	3
2	Air Permeability and Thermal Insulation Characteristics of I and C Group Low Density Foams.....	6
3	Air Permeability and Thermal Insulation Characteristics for I and C Group, 90 PPI Pore-Size, High-Density Foams.....	7
4	Thermal Insulation Characteristics of "In Use" and Candidate Fibrous Batt Materials With No Pressure Loading.....	10

# THERMAL INSULATION MATERIALS FOR DIVER'S UNDERWEAR GARMENT

## INTRODUCTION

The Navy Clothing and Textile Research Facility (NCTRF) studied the thermal insulation and compressional resistance properties of a group of open cell foam materials and one fibrous batt material for the Naval Coastal Systems Laboratory (NCSL), Panama City, Florida, to determine their suitability as insulation materials for divers' dry-suit underwear garments.

Previous studies conducted by NCSL (1) indicated that insulation values of 1.0 to 1.5 clo (2)<sup>1</sup> were necessary to limit body heat loss to 200 kcal for divers working in cold water for 1 to 2 hours. In addition, the insulation for divers' underwear had to be permeable. It had to allow the pressurized gaseous environment existing within the diver's dry suit [up to 450 psi (3102 kPa)] to freely penetrate the material to prevent extreme pressure squeeze on the material. However, the insulation needed suitable inherent compressional resistance to a pressure of 2 psi (13.8 kPa) that results from the differential hydrostatic head created along the length of the diver's body when vertical in the water.

To establish the range of thermal insulation and compressional resistance properties obtainable from open cell foams, NCTRF evaluated over 30 polyurethane foams having different pore size, densities, and thicknesses. Also a low-density polypropylene microfiber batt material having reportedly high thermal insulation values was included in the study. Measurements of thermal insulation and compressional resistance properties of some presently used diver underwear material and of two potential candidate foam materials were also made to establish what advantage the selected foam and fibrous materials might have with respect to these "in use" materials.

Results indicated that a fine pore open cell foam having a density of approximately 0.12 gr/cm<sup>3</sup> and the fibrous batt material at a density of 0.057 gr/cm<sup>3</sup> were superior to "in use" materials. At 2 psi (13.8 kPa) the foam compressed approximately 30% and the fibrous material 60%, whereas "in use" materials compressed at least 70%, with the worst compressing 83%. Insulation values for both the foam and fibrous materials were estimated to be 1.8 and 2.11 clo/cm at 2 psi (13.8 kPa), respectively.

This report covers the procedures and results of the material evaluations and discusses the results with respect to "in use" materials and performance requirements.

## MATERIAL DESCRIPTIONS

### "In Use" Types

The "in use" materials, as listed in Table 1, were pile and foam types. The materials identified as DU pile and AE pile were representative of plush and shearling pile fabrics, respectively, and those identified as V foam,

---

<sup>1</sup> clo = 0.155 deg C-m<sup>2</sup>/watts.

M12A foam, and M12B foam, were open cell foams. The DU and AE piles and the V foam were presently used materials, while the M12A and M12B foam materials were under consideration as potential underwear candidates. Unlike the other "in use" materials the M12B material was a composite type with its foam insulation element sandwiched between two outer skin materials. The outer material designed to be located farthest from the body had an aluminized reflective layer facing the foam. (All of the "in use" materials did not differ in density from the lightest to the heaviest by more than 60% or in thickness from the thinnest to the thickest by more than 48%.)

#### Open-Cell Foam Types

All the foams were made of polyurethane. (See Table 1 for characteristics.) One group which represented fully open types had an "I" designation in its code while the other group which had some cell membranes remaining had a "C" designation in its code. In both groups the samples represented a wide range of pore sizes (I-Group, 30 to 100 PPI<sup>2</sup>; C-Group, 20 to 100 PPI), densities (I-Group, 0.024 to 0.196 gr/cm<sup>3</sup>; C-Group, 0.027 to 0.296 gr/cm<sup>3</sup>, and thicknesses (I-Group, 0.305 to 1.32cm; C-Group, 0.284 to 1.28cm).

#### Fibrous Batt Type

The fibrous batt material (Table 1) were evaluated to establish their uncompressed thermal insulation values and compressional resistance characteristics. All open-cell foam types were also tested to determine their air permeability characteristics. The thermal insulation values of the "in use", of two selected open-cell foams and of the fibrous batt material were also determined at pressures to 0.44 psi (3 kPa). In addition all materials were weighed and their densities computed.

#### Thermal Insulation Tests

Thermal insulation values were obtained on a circular guarded hot plate similar in concept to that identified in ASTM Method ASTM D1518-64 Thermal Transmittance of Textile Fabric and Batting Between Guarded Hot-Plate and Cold Atmosphere (Figure 1). The plate had a 15.3-cm diameter central section, a guard ring width of 5 cm and a bottom guard plate equal in diameter to the combined central and guard ring sections. The central section and guards were regulated by electronic temperature

---

<sup>2</sup> PPI = Pores Per Linear Inch.

controllers. The central section controller maintained the temperature of this section at a set temperature (normally around 37 deg C) and the guard temperatures were regulated to follow the temperature of the central section by a differential temperature controller set for a 0 deg C difference. The guarded hot plate was located in a temperature-controlled environmental chamber and was shrouded to limit air velocities across the plate to less than 0.3 m/sec. The chamber was typically controlled at a temperature of 13 deg C. The temperatures of the central plate, guard, and chamber were monitored continuously by copper constantan thermocouples connected to a multipoint temperature recorder.

Table 1. Physical Characteristics of Materials Evaluated

Type	Group	Code	No. Samples	Avg. Density (gr/cm <sup>3</sup> )	Thick. Range (cm) <sup>1</sup>	Pore Size (PPI) <sup>2</sup>
In Use		DU Pile	1	0.047	1.220	
		AE Pile	1	0.050	1.220	
		V Foam	1	0.044	1.020	
		M12A Foam	1	0.070	0.826	
		M12B Foam	1	0.058	1.030	
Open Cell Foam	I	SI-30-2	3	0.025	0.338 to 1.270	30
		SI-45-2	3	0.027	0.721 to 1.320	45
		SI-80-2	1	0.029	1.300	80
		SI-100-2	2	0.024	0.305 to 0.678	100
		SI-90-6	1	0.093	0.663	90
		SI-90-7	2	0.117	0.810 to 0.843	90
		SI-90-8	3	0.122	0.508 to 0.663	90
		SI-90-9	1	0.150	0.650	90
		SI-90-10	1	0.171	0.668	90
	SI-90-12	2	0.196	1.18	90	
	C	SC-20-2	3	0.029	0.284 to 1.280	20
		SC-45-2	1	0.027	0.320	45
		SC-60-2	3	0.029	0.452 to 1.100	60
		SC-100-2	3	0.030	0.330 to 1.280	100
		SC-90-6	1	0.093	0.645	90
SC-90-9		1	0.154	0.663	90	
SC-90-12		1	0.195	0.699	90	
	SC-90-18	1	0.296	0.660	90	
Fibrous Batt		M400S	1	0.057	1.630	

<sup>1</sup> Pressure = 0.0001 psi (0.7 Pa).

<sup>2</sup> PPI = Pores Per Linear Inch.

Thermal energy to the central section was regulated by its controller by a time proportioning device which switched a constant voltage electrical power source feeding the central section heater at a rate required to maintain the temperature of the central section at the set point. Electronic timers which measured the total test time and central heater "on time" to within 0.1 second provided the means for determining the total thermal energy fed to the central plate during a test period. Thermal energy measurements to the central section were not made until the plate system and chamber temperatures had equilibrated.

To determine the thermal insulation resistance of a material, NCTRF first determined the thermal energy loss when the plate was bare and then calculated an equivalent thermal resistance value. This was referred to as the bare plate value. The material sample was then placed on the plate and the thermal energy needed to maintain the material-system in equilibrium was again established. The material-system thermal resistance was then computed. The thermal resistance of the material was then obtained by subtracting the thermal resistance of the bare plate from the thermal resistance of the material-system.

$$R_M = R_{M-S} - R_{BP} \quad (1)$$

$R_M$  = thermal resistance of material (clo)

$R_{M-S}$  = thermal resistance of material and system (clo)

$R_{BP}$  = thermal resistance of bare plate (clo)

For the plate described, the formula for calculating the thermal resistance is

$$R = \frac{466.37 (T_{CP} - T_R)}{I^2 \left[ \frac{\theta_o}{\theta_T} \right]} \quad (2)$$

R = thermal resistance (clo)

466.37 = constant for plate  $\left[ \frac{\text{clo (ma)}^2}{\text{deg C}} \right]$

$T_{CP}$  = Surface temperature of central plate (deg C)

$T_R$  = Temperature of chamber (deg C)

I = input current to central heater (ma)

$\theta_o$  = Central heater on time for selected total test time (sec)

$\theta_T$  = Total test time (sec)

or

$$R = \frac{466.37 (T_{CP} - T_R)}{I^2 \theta_R} \quad (3)$$

where

$$\theta_R = \frac{\theta_o}{\theta_T} = \text{Time on ratio}$$

The plate was designed to determine thermal insulation resistance of materials in an uncompressed state. To determine values under fixed compression pressures, NCTRF personnel applied loads to the materials through a 20-cm diameter, 0.8-mm-thick aluminum plate placed on top of the material. To minimize differences in surface condition between load and no-load tests, they used a ring stand with its three legs contacting the 20-cm aluminum plate along its edge. The loads were then applied to the platform of the ring stand (Figure 2). To prevent damage to the hot plate, NCTRF employed a 20-lb (89 N) maximum load with the ring structure. Tests were conducted with just the aluminum plate over the material [pressure 0.003 psi (0.02 kPa)], with the ring stand and a 10-pound (44 N) weight added [pressure 0.24 psi (1.65 kPa)], and with 20 pounds (89 N) added to the ring stand and plate [pressure 0.44 psi (3 kPa)].

To check the accuracy of the apparatus, tests on a high-density (0.096 gr/cm<sup>3</sup>) 2.54-cm-thick fiberglass sheet were compared with results from similar devices by the National Bureau of Standards (NBS) and the U. S. Army Natick Research and Development Command (NARADCOM) on equivalent materials. Differences in results were less than 5%.

#### Compression Tests

Tests were conducted in an Instron testing machine. Loads were applied to the specimens over a 500 cm<sup>2</sup> surface area. Two different load cells were employed: one had a full scale range of 100 gr, the other a full scale range of 45 kg. Depending on the sample tested or the pressure range being employed, static pressure loads on the samples were held for either a 1-minute or a 5-minute duration at each thickness reading. For the light pressure tests [0.0001 psi, (0.7 Pa)], the test samples were supported over their entire surface to minimize the effect of material droop on measured thickness. See Figure 3 for test setup.

#### Air Permeability

Air permeability was measured on a Frazier Air Permeability Test Apparatus in conformance with Method 5450.1 Permeability to Cloth, Calibrated Orifice Method, Federal Standard 191, except that the static pressure at which permeability was determined depended on the material flow resistance characteristic rather than the 0.5 in. H<sub>2</sub>O (0.12 kPa) value normally employed. For those materials with very high air permeability, the static pressure employed across the sample was 0.1 in. H<sub>2</sub>O (0.025 kPa). See Figure 4 for test setup.

## Material Weights

Material weights were measured on a balance readable to 0.1 gr. Sample sizes were approximately 900 cm<sup>2</sup>. Densities were computed with the material thickness measured at a pressure of 0.03 psi (0.21 kPa) for most materials. For the more easily deformable materials (piles and fibrous batt), densities were computed from the thickness value measured at a pressure of 0.0001 psi (0.7 Pa).

## RESULTS

### Air Permeability

Only the foam materials were tested to establish their air permeability characteristics. These tests were conducted primarily to judge the flow resistance (relative openness) to be expected for a certain pore size and foam thickness. For most materials the air pressure differential across the sample was 0.1 in. H<sub>2</sub>O (0.025 kPa). The results are given in Tables 2 and 3.

Table 2 Air Permeability and Thermal Insulation Characteristics of I and C Group Low Density Foams

MAT. ID Group   Code		Pore Size (PPI)	Air Perm. <sup>1</sup> $\frac{\text{ft}^3/\text{min}}{\text{ft}^2}$	Density (gr/cm <sup>3</sup> )	Thick. <sup>3</sup> (cm)	Thermal Resistance	
						Clo	Clo/cm
I	SI-30-2	30	595	0.024	0.338	0.35	1.04
		30	444	0.026	0.653	0.72	1.10
		30	330	0.025	1.270	1.46	1.15
	SI-45-2	45	338	0.028	0.721	0.78	1.08
		45	293	0.026	0.912	0.99	1.09
		45	218	0.027	1.320	1.71	1.30
	SI-80-2	80	84	0.029	1.300	2.39	1.84
	SI-100-2	100	292	0.022	0.305	0.46	1.51
		100	156	0.026	0.678	1.18	1.74
	C	SC-20-2	20	100	0.029	0.284	0.25
20			19	0.030	0.671	0.87	1.30
20			4	0.028	1.280	1.77	1.38
SC-45-2		45	256	0.027	0.320	0.36	1.13
SC-60-2		60	23	0.029	0.452	0.69	1.53
		60	47	0.028	0.643	1.10	1.71
		60	61	0.029	1.100	1.70	1.55
SC-100-2		100	2	0.033	0.330	0.54	1.64
		100	11	0.028	0.569	1.04	1.83
		100	27	0.031	1.280	2.36	1.84

<sup>1</sup> Differential Pressure = 0.1 in. H<sub>2</sub>O (0.025 kPa)

<sup>2</sup>  $\frac{\text{ft}^3/\text{min}}{\text{ft}^2} \times 5.08 \times 10^{-3} = \text{m/sec}$

<sup>3</sup> Static Pressure = 0.0001 psi (0.7 pa)

Table 3 Air Permeability and Thermal Insulation Characteristics for I and C Group, 90-PPI-Pore-Size, High-Density Foams

MAT. ID		Air Perm. <sup>1</sup> ft <sup>3</sup> /min <sup>2</sup> ft <sup>2</sup>	Density (gr/cm <sup>3</sup> )	Thick. <sup>5</sup> (cm)	Thermal Resistance	
Group	Code				Clo	Clo/cm
I	SI-90-6	34	0.093	0.663	1.29	1.95
	SI-90-7	17	0.116	0.810	1.57	1.94
		17	0.118	0.843	1.65	1.96
	SI-90-8	28	0.120	0.508	0.97	1.91
		29	0.124	0.508	0.94	1.85
		21	0.121	0.663	1.25	1.89
	SI-90-9	12	0.150	0.650	1.20	1.85
	SI-90-10	9	0.171	0.668	1.20	1.80
	SI-90-12	4	0.193	1.180	2.04	1.73
		4	0.199	1.180	2.03	1.72
C	SC-90-6	1	0.093	0.645	1.30	2.02
	SC-90-9	0.75 <sup>3</sup>	0.154	0.663	1.22	1.84
	SC-90-12	0.55 <sup>4</sup>	0.195	0.699	1.20	1.72
	SC-90-18	-	0.296	0.660	0.98	1.48

<sup>1</sup> Differential Pressure = 0.1 in. H<sub>2</sub>O (0.025 kPa)

<sup>2</sup>  $\frac{\text{ft}^3/\text{min.}}{\text{ft}^2} \times 5.08 \times 10^{-3} = \text{m/sec}$

<sup>3</sup> Differential Pressure = 0.5 in. H<sub>2</sub>O (0.120 kPa)

<sup>4</sup> Differential Pressure = 1.5 in. H<sub>2</sub>O (0.370 kPa)

<sup>5</sup> Static Pressure = 0.0001 psi (0.7 Pa)

At densities less than 0.03 gr/cm<sup>3</sup>, the I group materials (Table 2) passed substantial amounts of air [156 cfm/ft<sup>2</sup> (0.79 m/sec)] even in the finer pore sizes (100 PPI). At substantially higher densities, flow rates diminished considerably but were still significant (Table 3). A 0.99-gr/cm<sup>3</sup> density fine pore size (90 PPI) material passed air at a rate of 4 cfm/ft<sup>2</sup> (0.02 m/sec) at a 1.18-cm thickness. The flow resistance at any given porosity increased directly with thickness for all I group materials.

The C group materials exhibited much greater flow resistances than the I group types for a specific pore size and thickness at all densities (Tables 2 and 3). To obtain measureable airflow rates with the higher density C group materials, NCTRF had to increase the air pressure differential across some of the specimens. Not all C group materials having the same pore size exhibited an increase in flow resistance with thickness as their I group counterparts. This anomaly was apparently caused by variations in the number of cell membranes existing in a particular C-group material as well as the distribution of these membranes.

### Compressional Resistance

#### Foams

At low densities (0.022 to 0.033 gr/cm<sup>3</sup>) the I group foams, with the exception of one sample, compressed more than 50% at pressures as low as 0.5 psi (3.5 kPa). The C group foams showed good compressional resistance (less than 15%) at pressures to 0.5 psi (3.5 kPa). These materials, however, underwent significant thickness reductions (more than 50%) between 0.5 and 1.0 psi (3.5 and 6.9 kPa) (Figure 5). For each group the finer pore sizes had slightly better compressional resistance than the extremely coarse types (20 and 30 PPI) and the compression mechanism appeared to be the same for both. Each group showed good compressional resistance to some point and then underwent sizeable thickness changes with very little increase in load. After this deformation mode was complete, the foam structure again showed good compressional resistance. The materials experienced these considerable thickness changes between 0 and 0.5 psi (0 to 3.5 kPa) for the I group foams and between 0.5 and 1.0 psi (3.5 to 6.9 kPa) for the C group foams. All of these low density foams underwent thickness changes of more than 75% at 2.0 psi (13.8 kPa).

Results with similar foams of higher density showed greater compressional resistance than the low density samples (Figure 6). Compressional resistance increased directly with density for each group type. At densities of 0.12 gr/cm<sup>3</sup> and greater, thickness change at 2.0 psi (13.8 kPa) was less than 30%.

#### Fibrous Batt

The compressional resistance of the fibrous batt material (M400S) is given in Figure 7. This material showed a significant thickness change (47%) between 0 and 0.5 psi (0 and 3.5 kPa) and underwent an additional 13% thickness change between 0.5 and 2.0 psi (3.5 and 6.9 kPa).

#### "In Use" Materials

The compressional resistance of the "In Use" materials are given in Figure 7. All of these materials compressed more than 50% at pressures to 0.5 psi (3.5 kPa). The best, DU pile, compressed 70% at 2.0 psi (13.8 kPa) and the worst, M12B Foam, compressed 83% at 2.0 psi (13.8 kPa). Most of the "in use" materials showed a similar compressional resistance characteristic to the low density foams tested. All of these materials suffered significant

thickness changes with very little increase in load between 0 and 0.5 psi (0 and 3.5 kPa). For comparison purposes the compressional resistance characteristic for a 0.118 gr/cm<sup>3</sup>, 90 PPI, I group foam is also shown in Figure 7, identified as SI-90-8. It compressed less than 30% at 2.0 psi (13.8 kPa).

### Thermal Insulation Resistance

#### Foams

Low Density. Table 2 and Figures 8 and 9 give the thermal insulation characteristics for the I and C group low-density foams. For large pore sizes (low PPI number) insulation values were lower than for smaller size pores. Figure 8 shows that the 30-and-45-PPI I group foams had specific thermal resistances less than 1.3 clo/cm for any of the thicknesses tested, while the 80-and-100-PPI I group types had specific thermal resistances greater than 1.5 clo/cm for any thickness. Similar results were obtained on the C group foams, except that the specific thermal resistances for these foams were normally higher than for most thicknesses of the I group in the same pore size range. Specific thermal resistance, except for the 60 PPI C group material, increased with thickness. Most of the increase occurred at thicknesses below 0.6 cm for all but the 30-to-45-PPI I group pore sizes.

Figure 9 shows the relationship between specific thermal resistance and pore size in a more fundamental way by relating the thermal resistance directly to air permeability. When air permeability is plotted against specific thermal resistance, the resulting variations in thermal resistance can be attributed to heat transfer mechanisms such as convection and radiation since both gaseous and solid conduction effects would be normalized. The general trend of the curve (thermal resistance increases as air permeability decreases) can be associated with a reduction in convection heat loss with reduced permeability. The scatter below and above the curve can be associated with radiational heat loss. The coarser materials (lower PPI) tended to show lower thermal resistance at a specific air permeability value.

High Density. Table 3 and Figure 10 provide the thermal insulation characteristics for 90-PPI-pore-size I and C group high-density foams. Figure 10 shows the relationship between the specific thermal resistance and density for both groups. For a 3-to-1 density range the results indicate a linear decreasing specific thermal resistance with density for both groups. At these higher densities and fineness of pore size, both foam groups produced almost similar results. The specific thermal resistance of the foams decreased at a slope of approximately 2.49 clo/cm per gr/cm<sup>3</sup>.

"In Use" Materials

No Pressure Loading. Table 4 and Figure 11 give the thermal insulation characteristics for the "in use" and candidate fibrous batt materials with no pressure loading. For comparison purposes Figure 11 also includes results for a 90-PPI, I-group, high-density foam. Figure 11 demonstrates that the fibrous M400S batt material had the highest specific thermal resistance, and that the foam materials V, SI-90-8, M12B, and M12A were second best. The pile materials DU and AE were the worst. The best of the foams (V) and pile materials (DU) were about 9 and 41% lower, respectively, in specific thermal resistance than the batt material. The four foam materials differed in specific thermal resistance by only 18%.

Table 4 Thermal Insulation Characteristics of "In Use" and Candidate Fibrous Batt Materials With No Pressure Loading

Mat. ID	Density (gr/cm <sup>3</sup> )	Thick. <sup>1</sup> (cm)	Thermal Resistance	
			Clo	Clo/cm
DU Pile	0.047	1.220	1.65	1.35
AE Pile	0.050	1.220	1.55	1.27
V. Foam	0.044	1.020	2.11	2.07
M12A Foam	0.070	0.826	1.44	1.74
M12B Foam	0.058	1.030	1.98	1.92
M400S Batt	0.057	1.630	3.70	2.27

<sup>1</sup> Static Pressure = 0.0001 psi (0.7 Pa)

Pressure Loading. Figure 12 portrays the change in intrinsic thermal resistance with pressure for the "in use" and candidate fibrous batt and I group foam materials. The small loss in intrinsic thermal resistance for the 90-PPI, I-group, high-density foam in relation to the other materials can readily be seen. The loss in thermal resistance for this material was less than 16% at 0.44 psi (3.0 kPa), while the next least affected material was the V foam which decreased approximately 40% at 0.44 psi (3.0 kPa). At 0.44 psi (3.0 kPa) the M12B foam material showed the greatest loss in intrinsic thermal resistance (56%), while the others were somewhat similar showing a loss of 47 to 51%.

## DISCUSSION OF RESULTS

The compressional resistance data obtained on the evaluated materials showed that none of the low-density foams were suitable for use in divers' underwear. The only foam materials that had the required degree of compressional resistance were those with densities greater than  $0.12 \text{ gr/cm}^3$  [loss of thickness at 2 psi (13.8 kPa) less than 30%]. A fine pore structure was also deemed necessary if thermal resistance was to be maximized for any particular foam type. On the basis of compressional resistance alone, the fibrous batt material was unsatisfactory [compressed 60% at 2 psi (13.8 kPa)] but, because of its high initial specific thermal resistance (2.27 clo/cm), it was still considered a viable candidate. NCTRF expected that a high density foam and the fibrous batt material would perform better than any of the "in use" materials since both compressed less than the "in use" materials and had essentially equal or better initial specific thermal resistance characteristics. To construct an underwear garment from the foam, NCTRF thought the maximum suitable density was  $0.12 \text{ gm/cm}^3$ . Tested foams of greater density appeared too boardy or stiff.

To predict the thermal performance of the foam candidate at 2 psi (13.8 kPa), NCTRF associated its thickness change with an apparent increase in density and then related this change to the thermal resistance-density results of Figure 10. For example, a  $0.128 \text{ gm/cm}^3$  fine pore foam which compresses 30% at 2 psi (13.8 kPa) would have an apparent density of  $0.166 \text{ gm/cm}^3$ , and from Figure 10 its specific thermal resistance could be estimated as 1.8 clo/cm. At 0.44 psi (3.0 kPa) (Figure 7), the fibrous batt material compressed about 46% and underwent a 51% reduction in thermal resistance. Thus, for the pressure change of 0.44 psi (3.0 kPa) and the corresponding thickness (apparent density) change of 46%, the specific resistance value changed from 2.27 to 2.15 clo/cm. If, as in the case of the foam materials, specific thermal resistance decreases linearly as density increases (reduction in thickness), the slope of the change in specific resistance with change in thickness would be 0.261 clo/cm per cm. At 2.0 psi (13.8 kPa) the specific resistance would then be 2.11 clo/cm.

The two materials selected for the initial underwear garments were: a  $0.128 \text{ gr/cm}^3$ , 90 PPI foam in thicknesses of 0.47 and 0.79 cm along with the  $0.057 \text{ gr/cm}^3$  M400S batt material at approximately the 1.63-cm thickness evaluated and at half this thickness (0.82cm). The thickness selections were based not only on insulation requirements but also on a need to maintain a low garment profile for maneuverability. The 0.47 and 0.79 cm thick foams have an estimated thermal resistance of 0.92 and 1.54 clo, respectively, at 0 pressure (1.95 clo/cm) and 0.59 and 1.0 clo (1.8 clo/cm and a 30% thickness reduction) at 2 psi (13.8 kPa). The 0.82 and 1.63 cm thick batt materials have an estimated thermal resistance of 1.86 and 3.70 clo, respectively, at 0 pressure (2.27 clo/cm) and 0.69 and 1.38 clo (2.11 clo/cm and a 60% thickness reduction) at 2 psi (13.8 kPa). The thicker foam and batt materials will meet the minimum 1 clo thermal requirement (1) at 2 psi (13.8 kPa) but their thinner counterparts will not. It is anticipated that the thinner materials will be used in the upper portion of the underwear garments where the pressure squeeze is less than 2 psi (13.8 kPa).

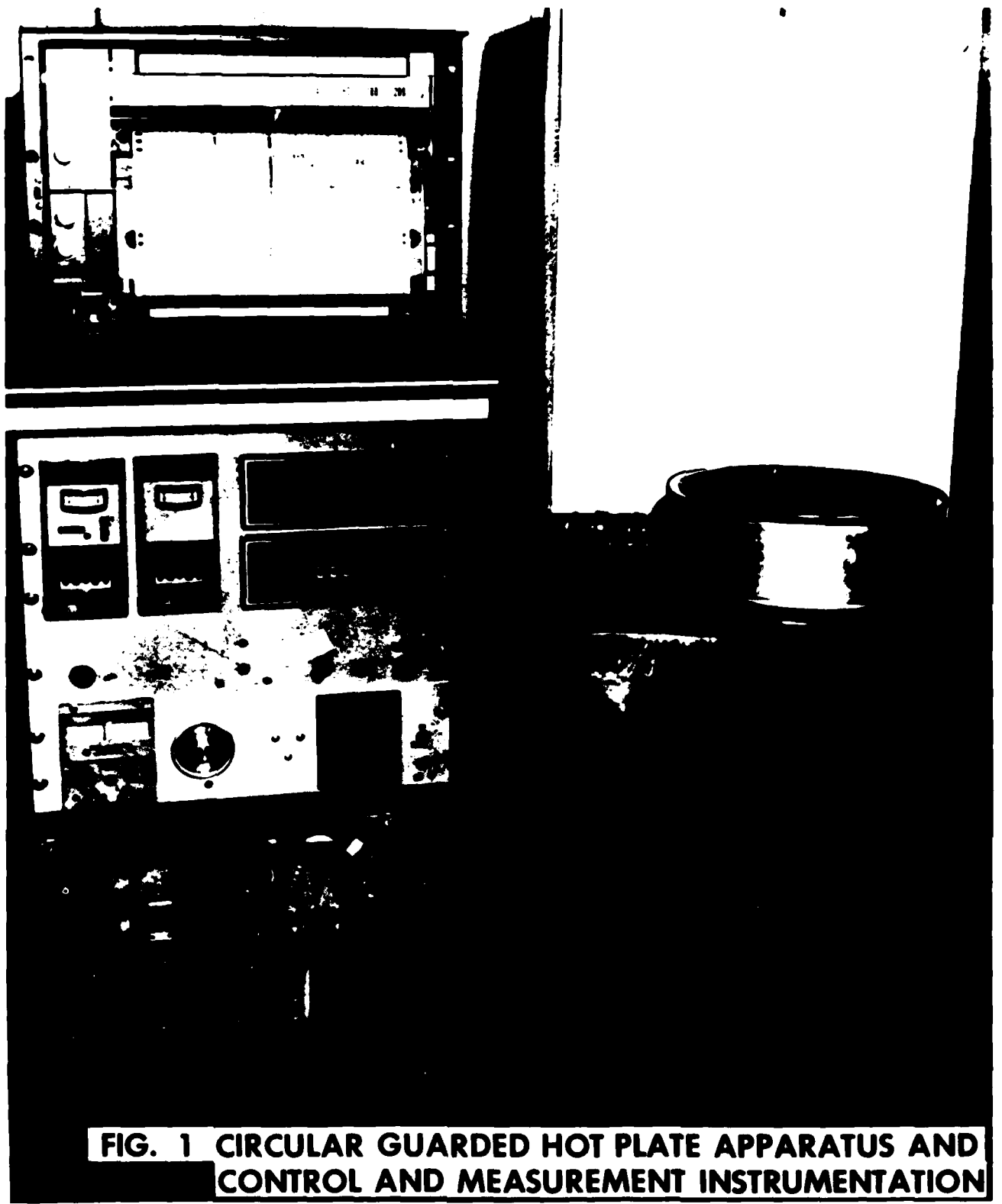
## CONCLUSIONS

1. When adequate compressional resistance to pressures up to 2 psi (13.8 kPa) with open cell foams is desired, densities should be 0.12 gr/cm<sup>3</sup> or more (thickness loss less than 30%).
2. When thermal insulation resistance for a specific foam material should be maximized, fine pore sizes should be employed.
3. The maximum density for open cell foams flexible enough to be used in clothing applications should be 0.12 gr/cm<sup>3</sup>.
4. A fine pore open cell foam at a density of 0.12 gr/cm<sup>3</sup> will meet minimum thermal insulation requirements (1 clo) at 2.0 psi (13.8 kPa) with an initial uncompressed thickness of 0.79 cm or more.
5. Even though it undergoes significant compression (60%) at pressures of 2 psi (13.8 kPa), the microfiber batt material in densities of 0.057 gr/cm<sup>3</sup> meets minimum thermal insulation requirements with an initial uncompressed thickness of 1.18 cm or more because of its estimated high specific thermal resistance at 2.0 psi (13.8 kPa) of approximately 2.11 clo/cm.
6. The selected foam and fibrous batt materials were considered superior to all "in use" materials because of: better compressional resistance at pressures to 2.0 psi (13.8 kPa) and approximately equal or superior specific thermal insulation resistance when uncompressed.

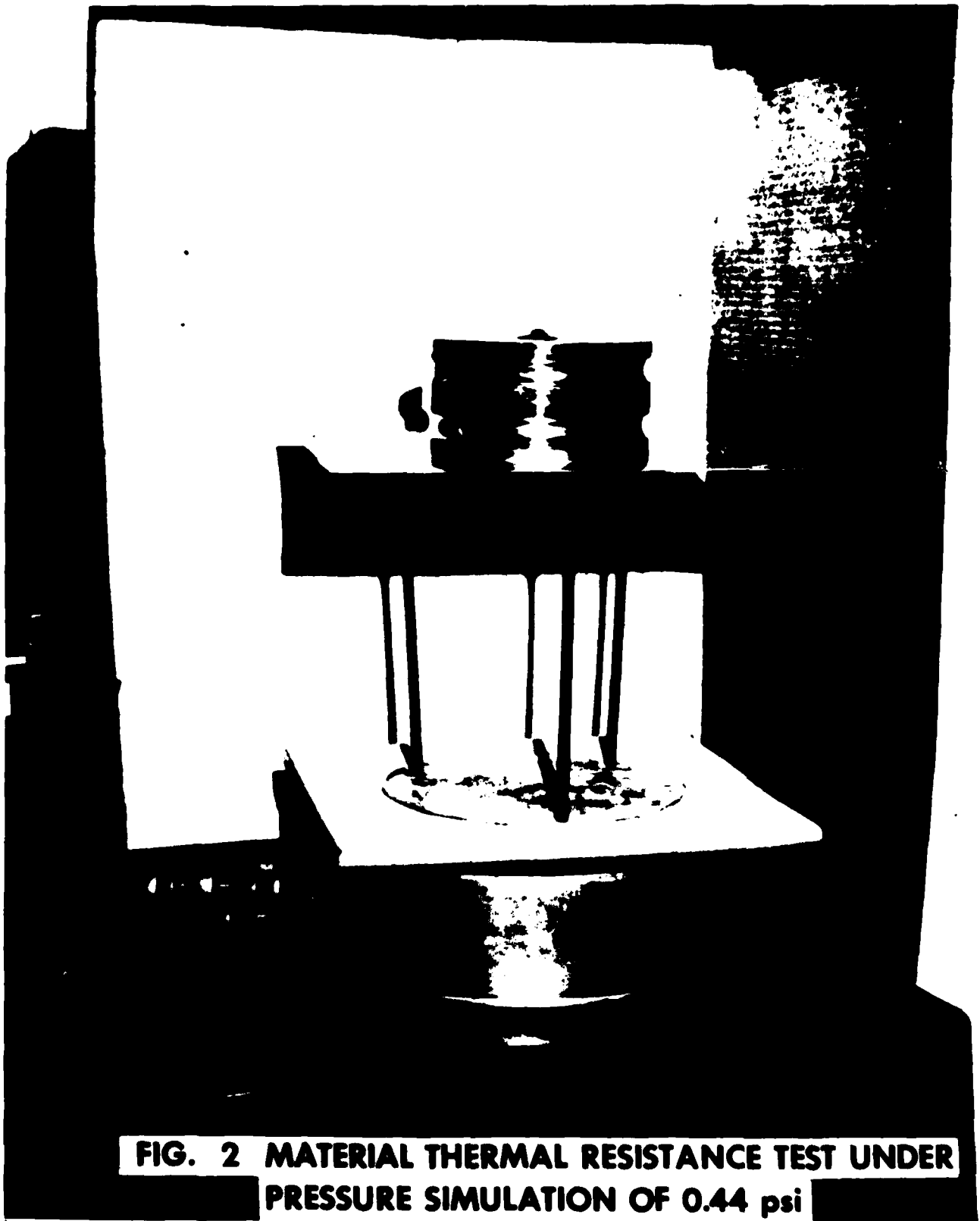
## REFERENCES

- 1 Nuckols, M. L., "Thermal Considerations in the Design of Divers' Suits," Technical Memorandum NCSL TM 218-78, Jan. 1978, Naval Coastal Systems Laboratory, Panama City, FL.
- 2 Newburgh, L. H., Physiology of Heat Regulation, W.B. Saunders, Philadelphia, 1949, p. 450.

APPENDIX A. ILLUSTRATIONS



**FIG. 1 CIRCULAR GUARDED HOT PLATE APPARATUS AND CONTROL AND MEASUREMENT INSTRUMENTATION**



**FIG. 2 MATERIAL THERMAL RESISTANCE TEST UNDER  
PRESSURE SIMULATION OF 0.44 psi**

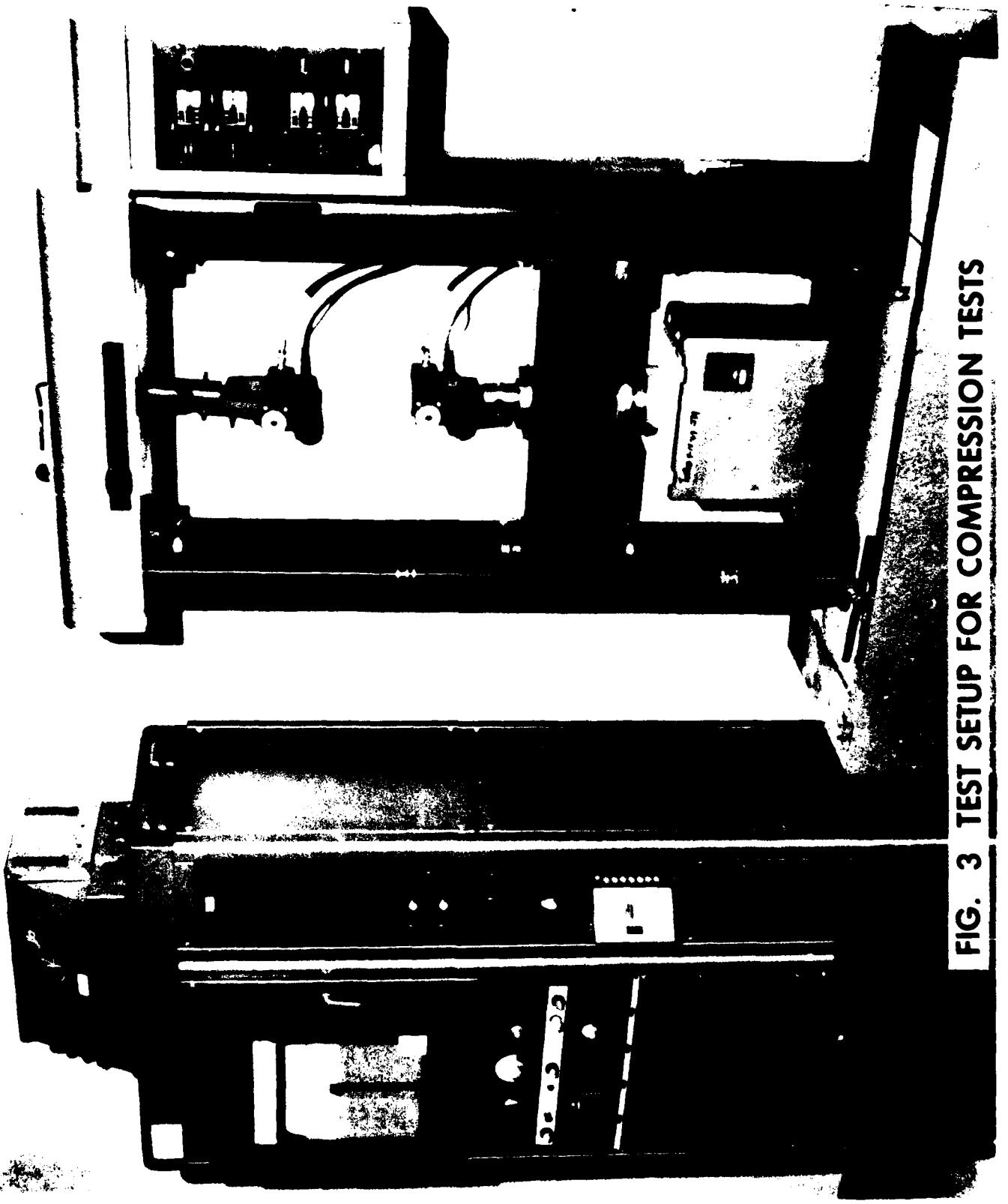
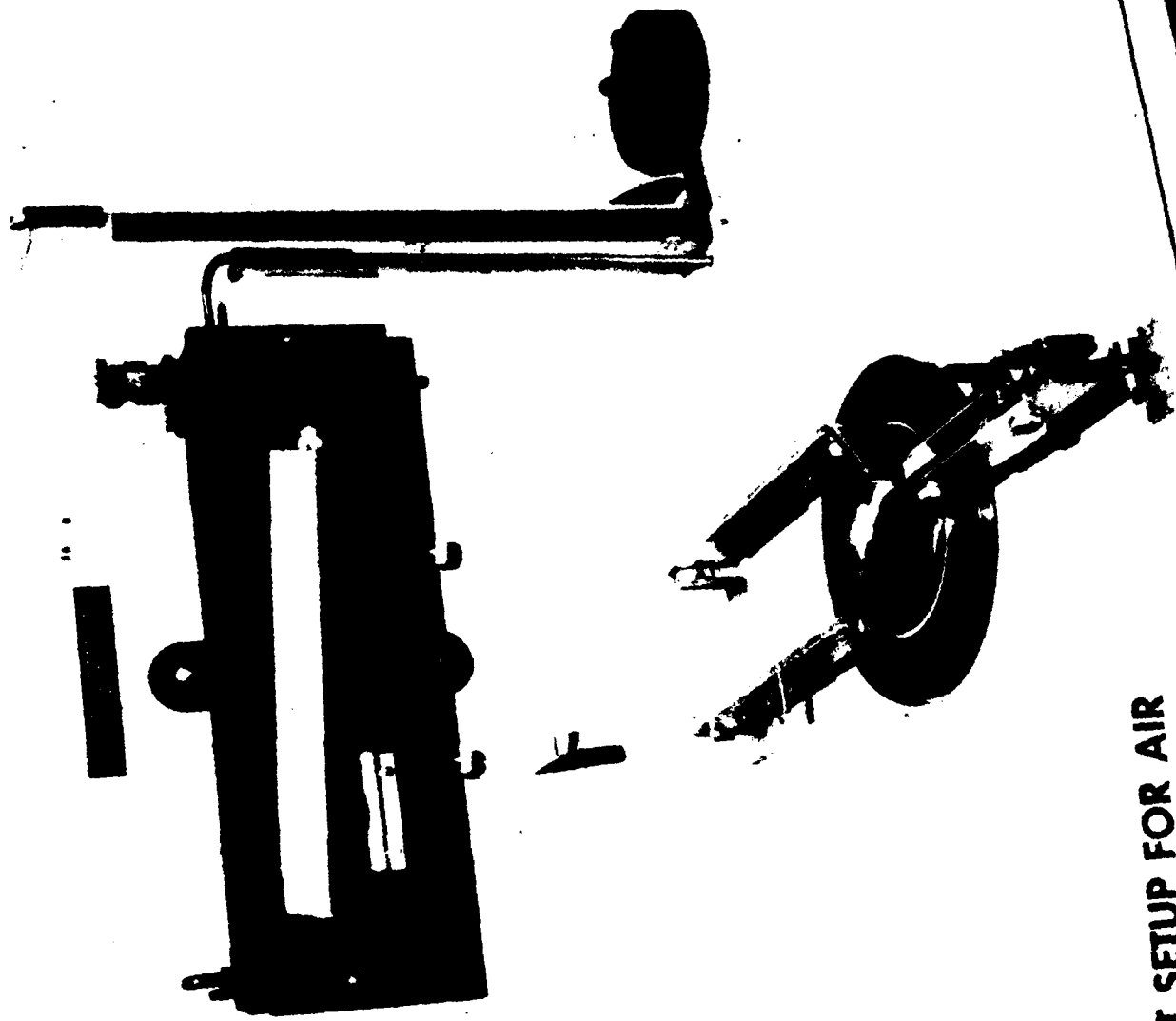


FIG. 3 TEST SETUP FOR COMPRESSION TESTS



**FIG. 4 TEST SETUP FOR AIR PERMEABILITY TESTS**

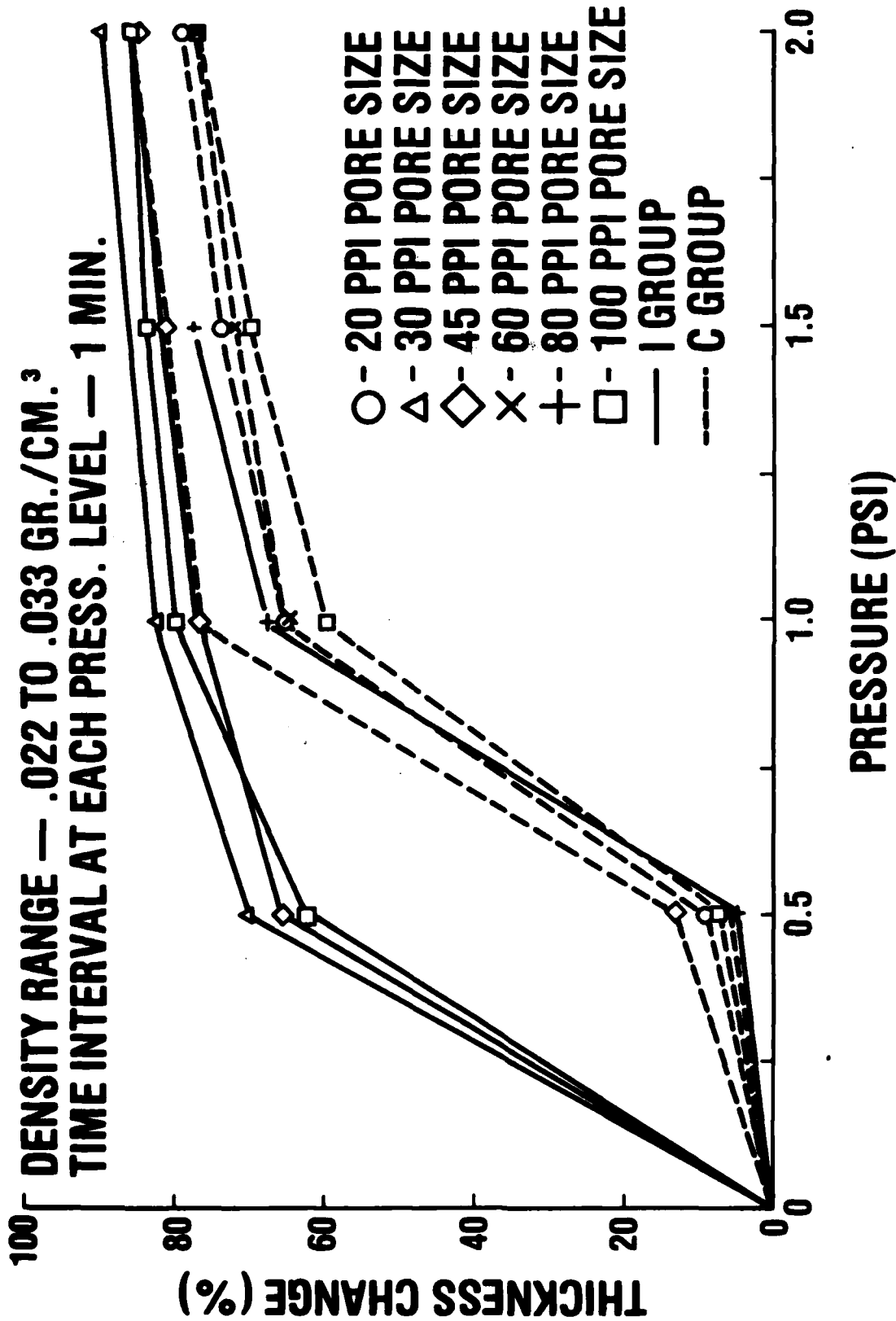
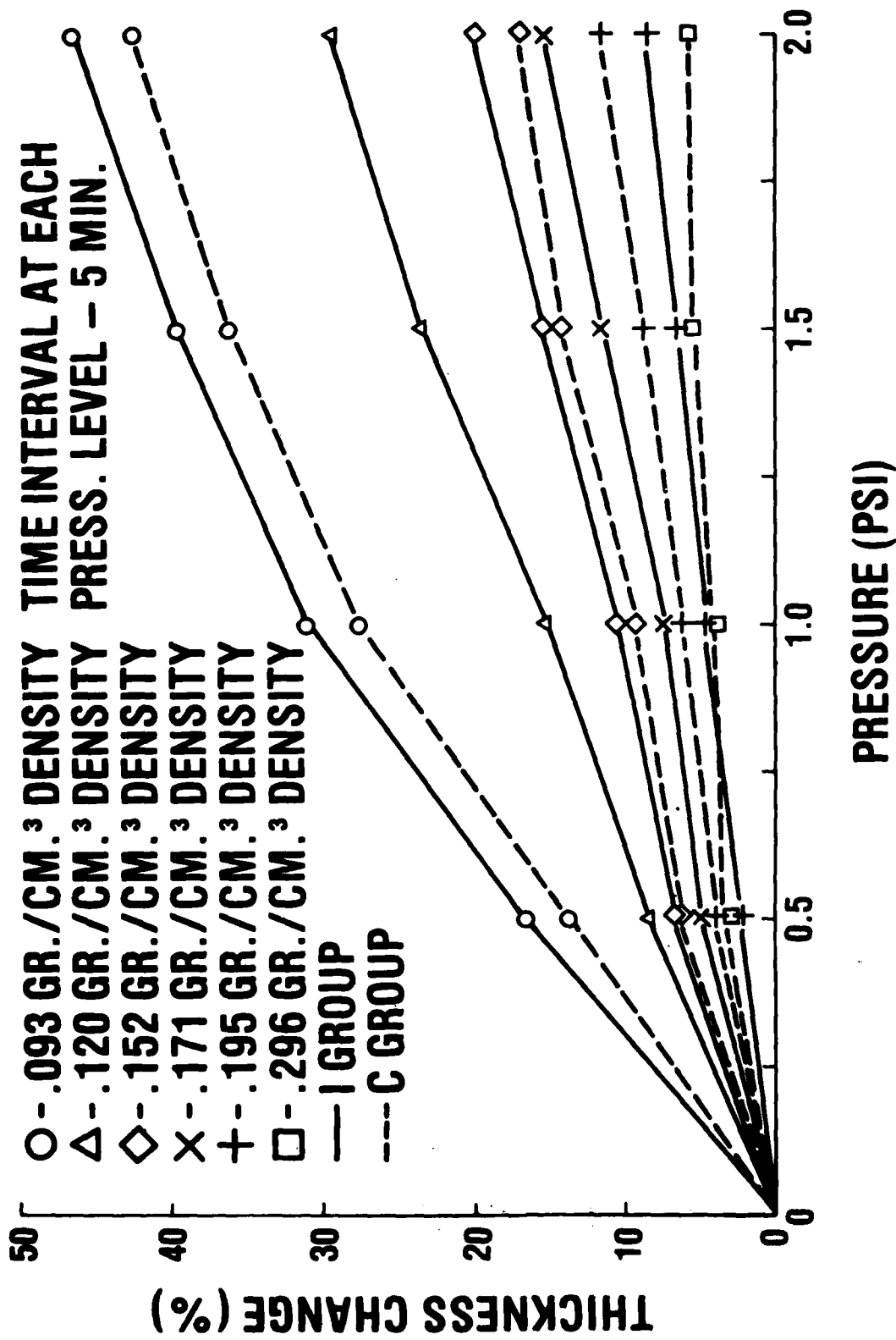
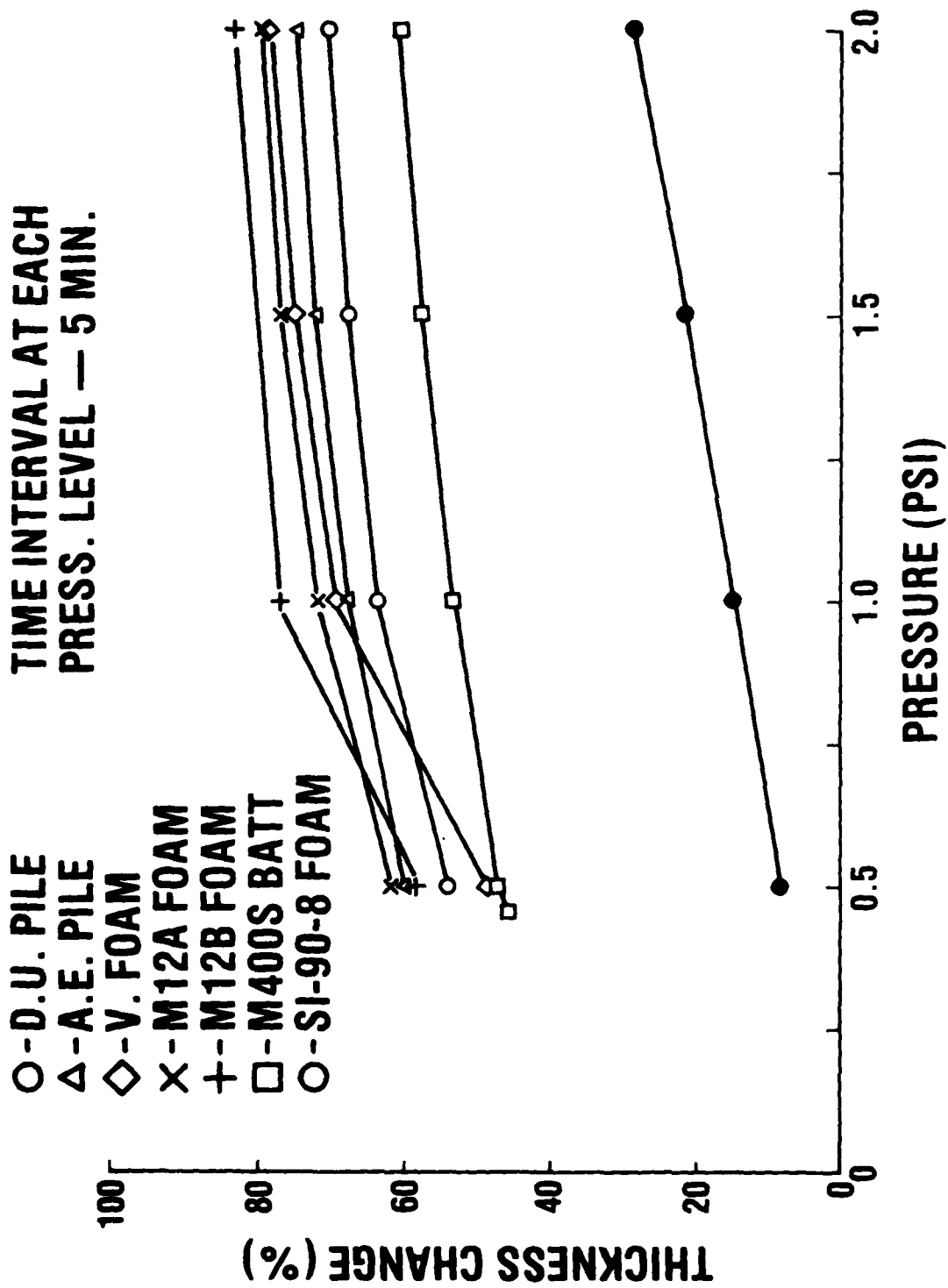


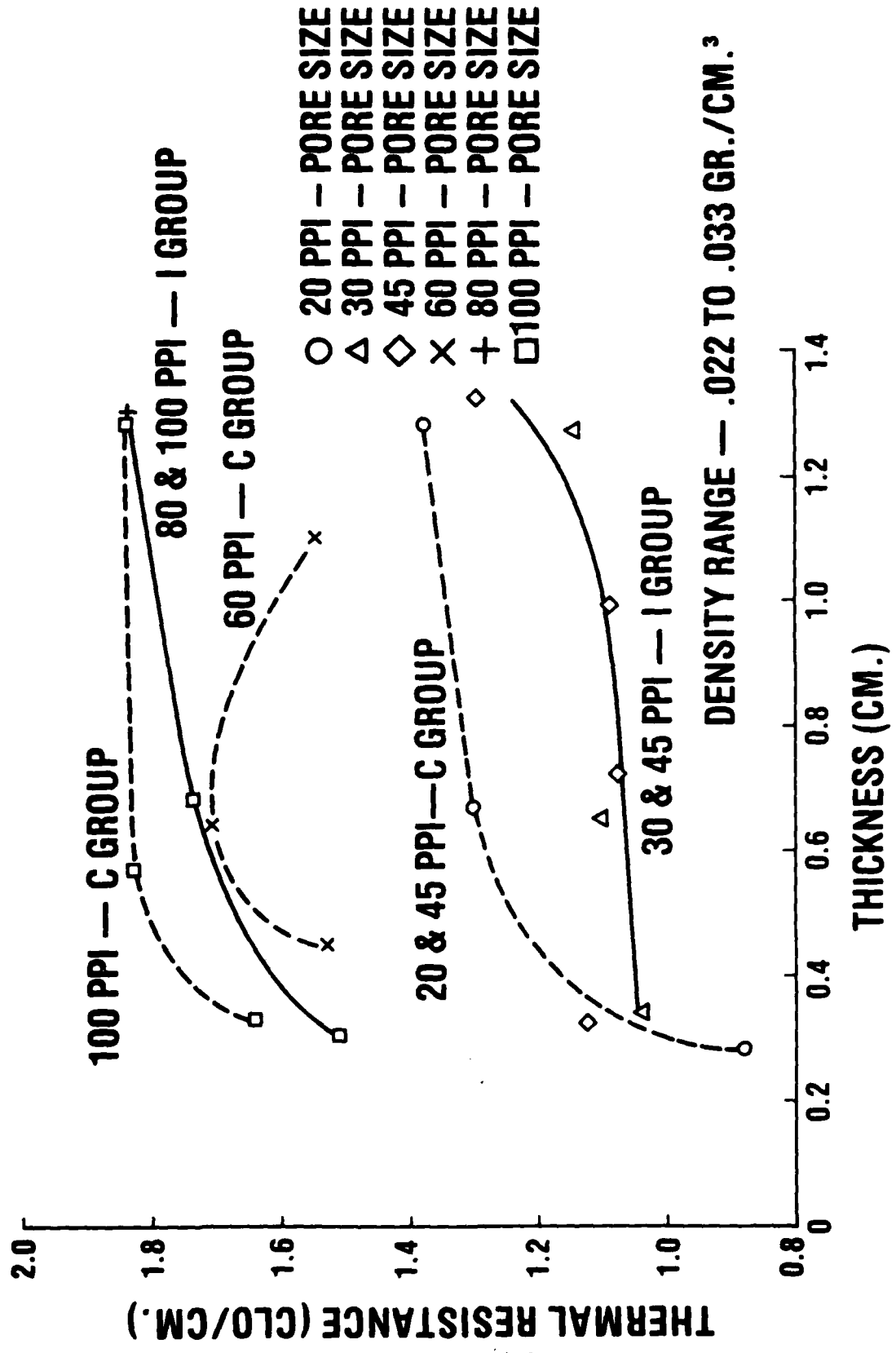
FIG. 5 THICKNESS CHANGE VS. PRESSURE FOR  
 I AND C GROUP LOW DENSITY FOAMS



**FIG. 6 THICKNESS CHANGE VS. PRESSURE FOR I AND C GROUP 90 PPI PORE SIZE HIGH DENSITY FOAMS**

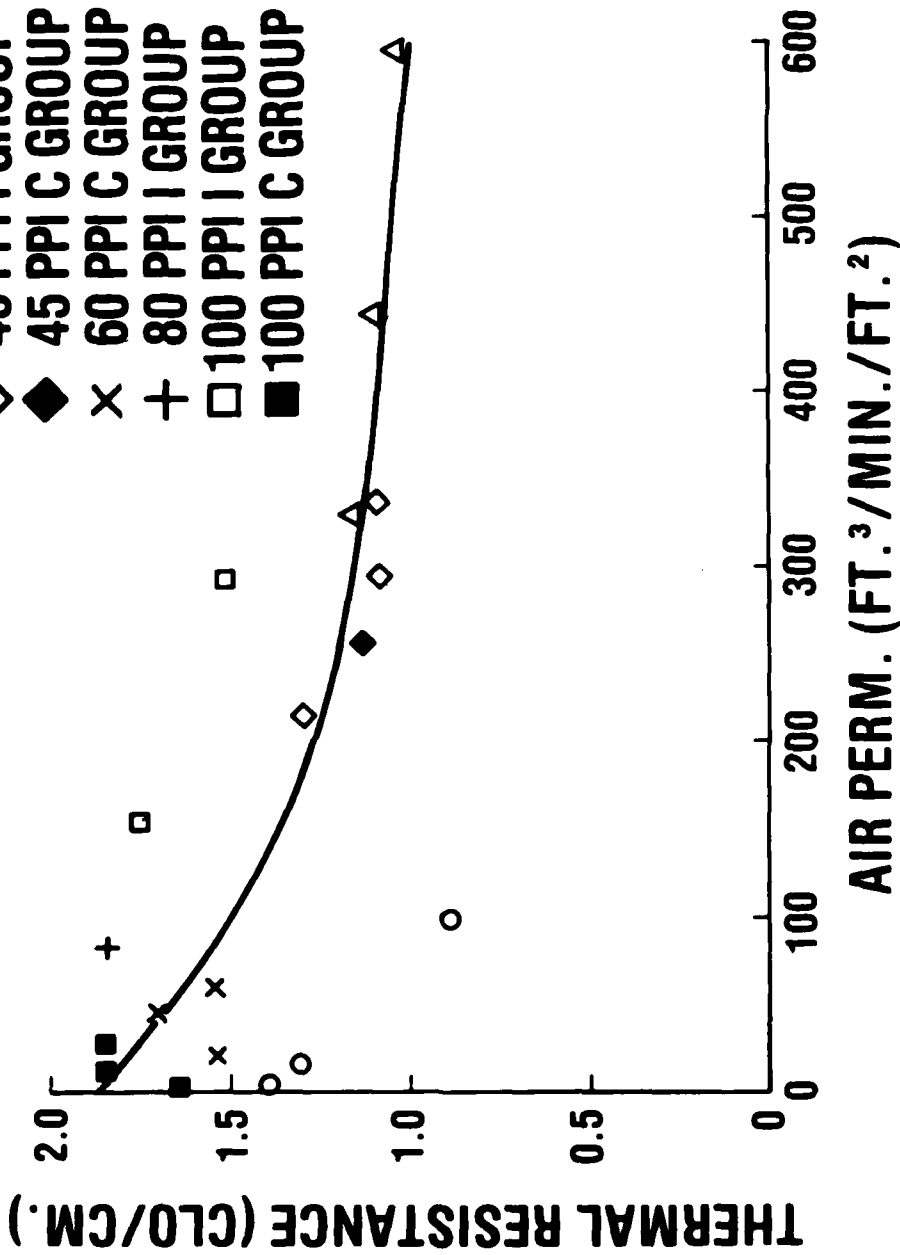


**FIG. 7 THICKNESS CHANGE VS. PRESSURE FOR "IN USE" AND CANDIDATE FIBROUS BATT AND I GROUP FOAM MATERIALS**

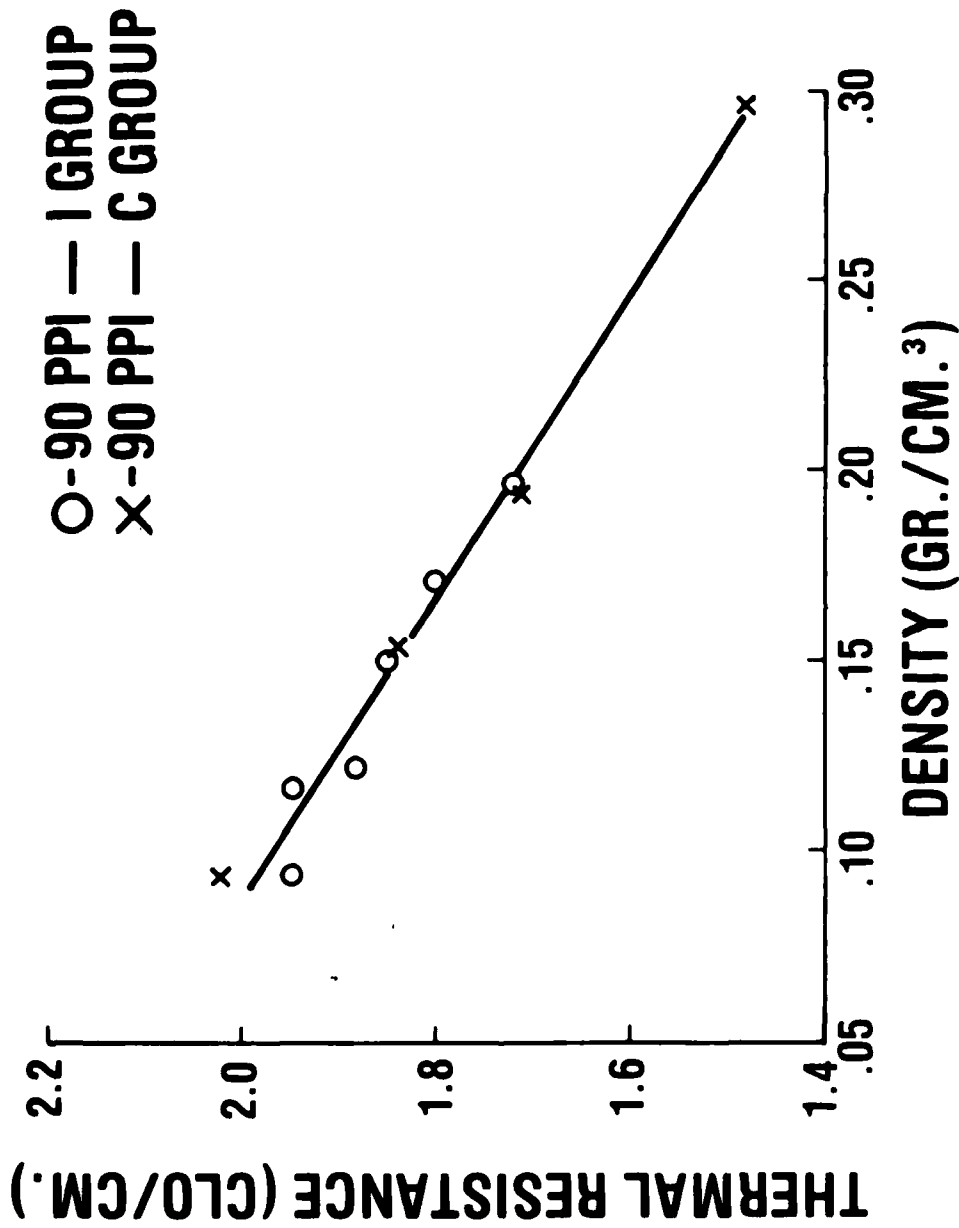


**FIG. 8 SPECIFIC THERMAL RESISTANCE VS. THICKNESS FOR I AND C GROUP LOW DENSITY FOAMS**

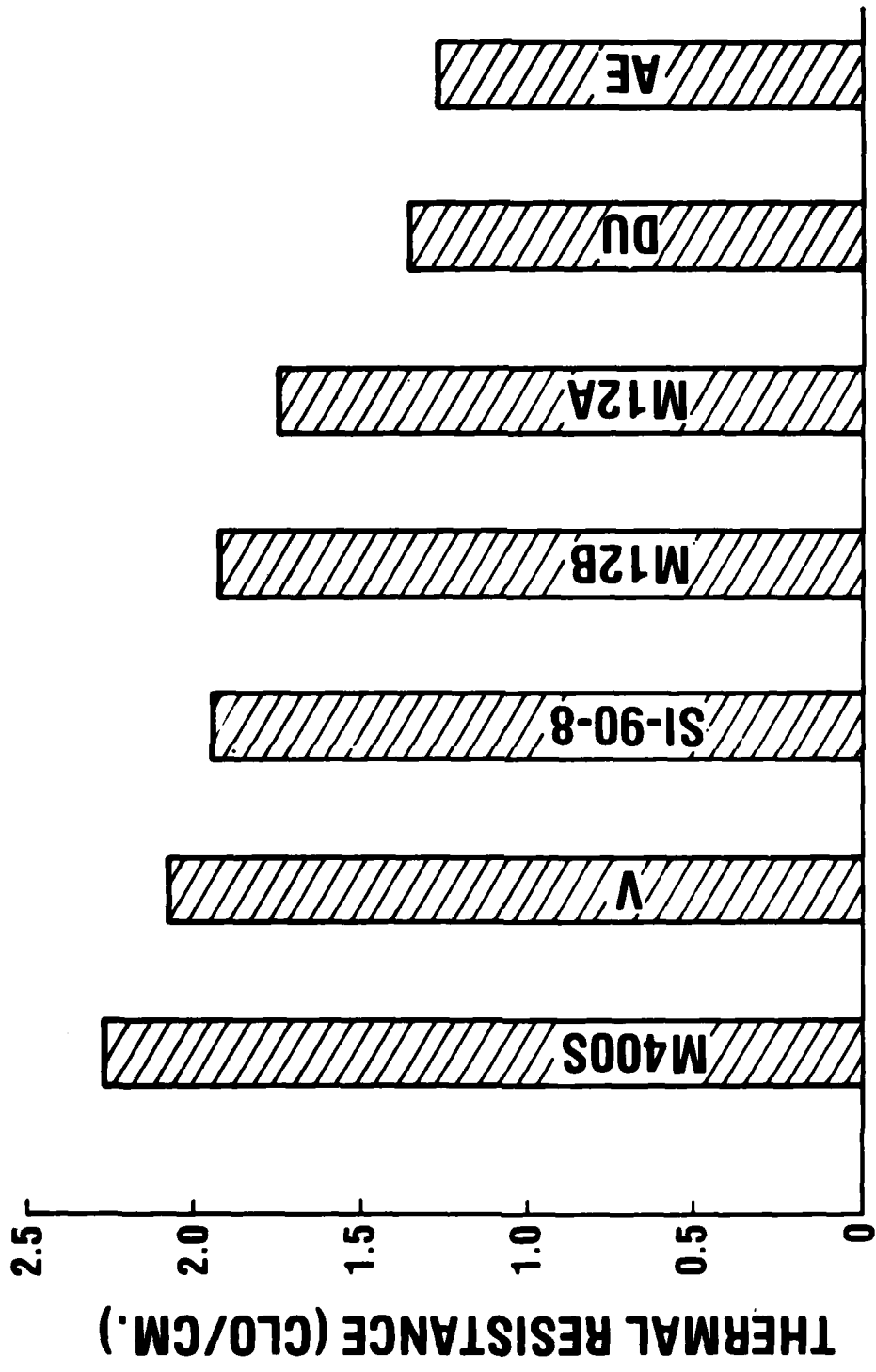
- 20 PPI C GROUP
- △ 30 PPI I GROUP
- ◇ 45 PPI I GROUP
- ◆ 45 PPI C GROUP
- × 60 PPI C GROUP
- + 80 PPI I GROUP
- 100 PPI I GROUP
- 100 PPI C GROUP



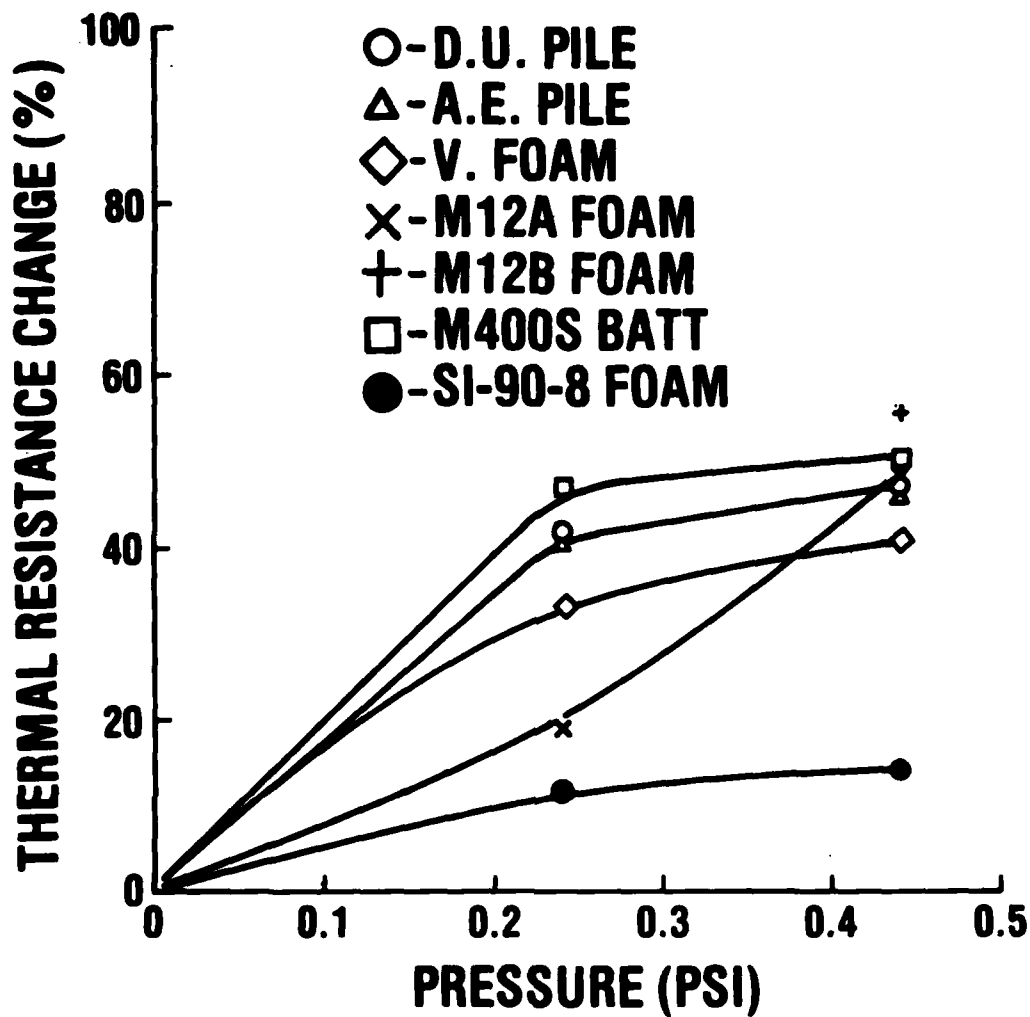
**FIG. 9 SPECIFIC THERMAL RESISTANCE VS. AIR PERMEABILITY FOR I AND C GROUP LOW DENSITY FOAMS**



**FIG. 10 SPECIFIC THERMAL RESISTANCE VS. DENSITY FOR I AND C GROUP 90 PPI PORE SIZE FOAMS**



**FIG. 11 COMPARISON OF SPECIFIC THERMAL RESISTANCE OF "IN USE" AND CANDIDATE FIBROUS BATT AND I GROUP FOAM MATERIALS WITH NO PRESSURE LOADING**



**FIG. 12 INTRINSIC THERMAL RESISTANCE CHANGE VS. PRESSURE FOR "IN USE" AND CANDIDATE FIBROUS BATT AND I GROUP FOAM MATERIALS**