

AD-A086 859

NAVAL OCEAN SYSTEMS CENTER SAN DIEGO CA  
REMOTE UNMANNED WORK SYSTEM PRIMARY CABLE TERMINATION AND POTTI--ETC(U)

F/G 13/9

JUN 80 R S STARK

UNCLASSIFIED

NOSC/TD-350

NL

1 of 1  
40  
7/2/89

NOSC

|  |  |  |  |  |  |  |  |  |  |  |  |  |  |
|--|--|--|--|--|--|--|--|--|--|--|--|--|--|
|  |  |  |  |  |  |  |  |  |  |  |  |  |  |
|  |  |  |  |  |  |  |  |  |  |  |  |  |  |
|  |  |  |  |  |  |  |  |  |  |  |  |  |  |

END

DATE

FILED

8-80

DTIC

✓ (12) LEVEL II

# NOSC

NOSC TD 350

NOSC/TD-350

Technical Document 350

(6) **REMOTE UNMANNED WORK SYSTEM  
PRIMARY CABLE TERMINATION AND  
POTTING PROCEDURES,**

ADA 086859

*Final Rpt. 1970-1978*

(10) Robert S. Stark

(11) Jun 1980

(12) 39

Prepared for  
Naval Sea Systems Command

(17) SA 207101  
116-111

**S** DTIC ELECTE **D**  
JUL 21 1980  
**B**

Approved for public release; distribution unlimited

NAVAL OCEAN SYSTEMS CENTER  
SAN DIEGO, CALIFORNIA 92152

27-157  
80 7 18 013

DDC FILE COPY



NAVAL OCEAN SYSTEMS CENTER, SAN DIEGO, CA 92152

---

**A N A C T I V I T Y O F T H E N A V A L M A T E R I A L C O M M A N D**

**SL GUILLE, CAPT, USN**

Commander

**HL BLOOD**

Technical Director

### **ADMINISTRATIVE INFORMATION**

This document presents information concerning the methods and materials considered most effective in field termination and potting of the primary cable for the Remote Unmanned Work System (RUWS). It is intended to assist those individuals who will be working with the cable at sea and in the field.

This work was performed at the Naval Ocean Systems Center Hawaii Laboratory as a part of the Deep Ocean Technology (DOT) program.

Released by  
**JK KATAYAMA, Head**  
Ocean Systems Division

Under authority of  
**JD HIGHTOWER, Head**  
Environmental Sciences Department

UNCLASSIFIED

SECURITY CLASSIFICATION OF THIS PAGE (When Data Entered)

| REPORT DOCUMENTATION PAGE  |                                      | READ INSTRUCTIONS<br>BEFORE COMPLETING FORM   |
|--|--------------------------------------|---|
| 1. REPORT NUMBER<br>NOSC TD 350 ✓  | 2. GOVT ACCESSION NO.<br>AD-A086 859 | 3. RECIPIENT'S CATALOG NUMBER   |
| 4. TITLE (and Subtitle)<br>REMOTE UNMANNED WORK SYSTEM PRIMARY CABLE<br>TERMINATION AND POTTING PROCEDURES   |                                      | 5. TYPE OF REPORT & PERIOD COVERED<br>Final: 1978-1980  |
|  |                                      | 6. PERFORMING ORG. REPORT NUMBER  |
| 7. AUTHOR(s)<br>R.S. STARK   |                                      | 8. CONTRACT OR GRANT NUMBER(s)  |
| 9. PERFORMING ORGANIZATION NAME AND ADDRESS<br>Naval Ocean Systems Center, Hawaii Laboratory<br>P. O. Box 997<br>Kailua, Hawaii 96734  |                                      | 10. PROGRAM ELEMENT, PROJECT, TASK<br>AREA & WORK UNIT NUMBERS<br>63712N; S0397-SL 14669;<br>533-MS67 |
| 11. CONTROLLING OFFICE NAME AND ADDRESS<br>Naval Sea Systems Command<br>Department of the Navy<br>Washington, D. C. 20360  |                                      | 12. REPORT DATE<br>June 1980  |
|  |                                      | 13. NUMBER OF PAGES<br>36   |
| 14. MONITORING AGENCY NAME & ADDRESS (if different from Controlling Office)  |                                      | 15. SECURITY CLASS. (of this report)<br>Unclassified  |
|  |                                      | 15a. DECLASSIFICATION/DOWNGRADING<br>SCHEDULE   |
| 16. DISTRIBUTION STATEMENT (of this Report)<br><br>Approved for public release; distribution unlimited.  |                                      |   |
| 17. DISTRIBUTION STATEMENT (of the abstract entered in Block 20, if different from Report)   |                                      |   |
| 18. SUPPLEMENTARY NOTES  |                                      |   |
| 19. KEY WORDS (Continue on reverse side if necessary and identify by block number)<br>Electromechanical cable<br>Potting compounds<br>Potting procedures<br>Termination  |                                      |   |
| 20. ABSTRACT (Continue on reverse side if necessary and identify by block number)<br>This procedure for potting and terminating the strength and electrical portions of the primary cable of the Remote Unmanned Work System (RUWS) are discussed. Also included are lists of tools and materials to be used in the process. |                                      |   |

DD FORM 1473  
1 JAN 73

EDITION OF 1 NOV 65 IS OBSOLETE  
S/N 0102-LF-014-6601

UNCLASSIFIED

SECURITY CLASSIFICATION OF THIS PAGE (When Data Entered)

UNCLASSIFIED  
SECURITY CLASSIFICATION OF THIS PAGE (When Data Entered)

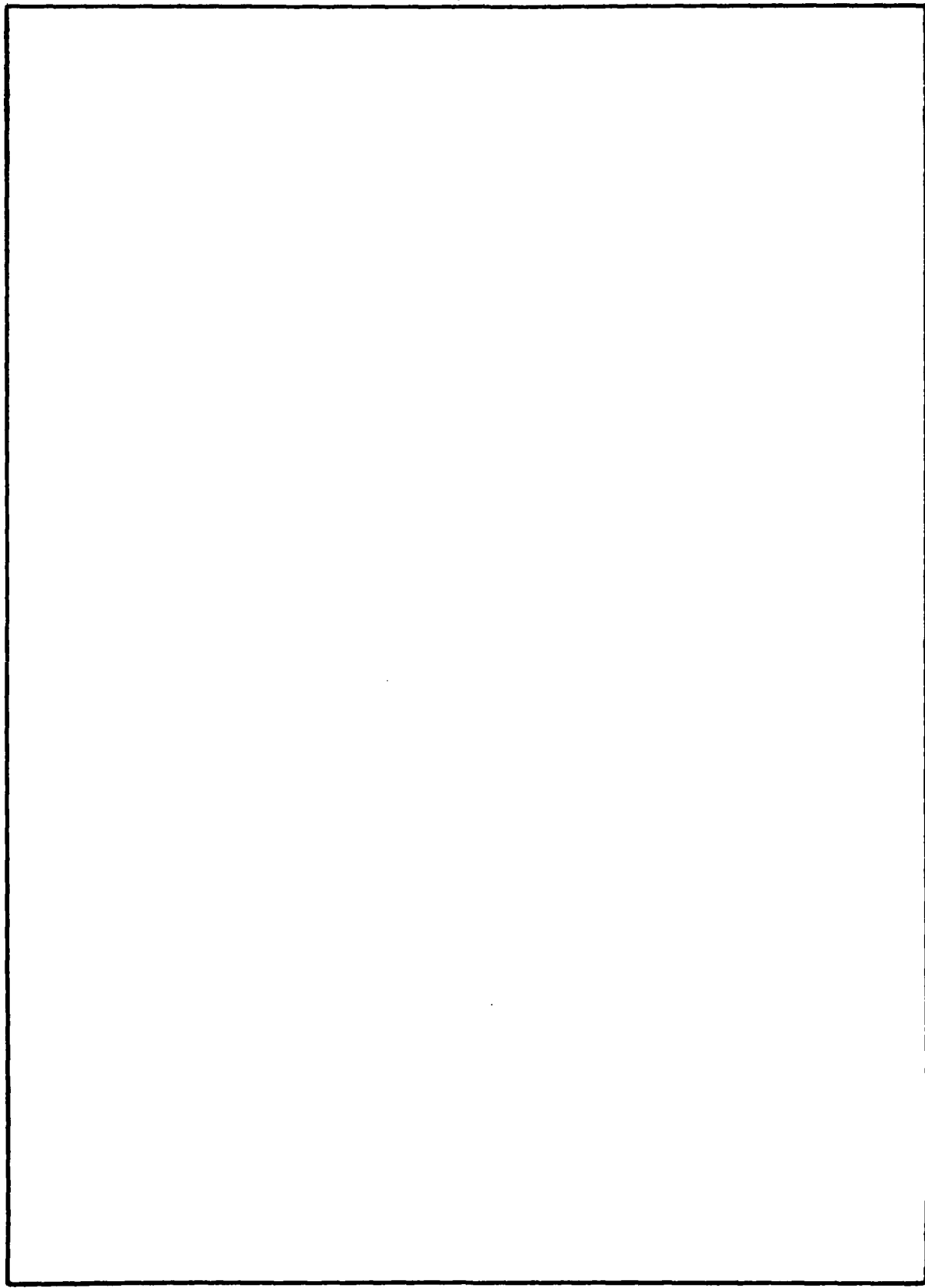

UNCLASSIFIED  
SECURITY CLASSIFICATION OF THIS PAGE (When Data Entered)

## CONTENTS

INTRODUCTION . . . page 3

DESCRIPTIONS . . . 3

REMOTE UNMANNED WORK SYSTEM . . . 3

PRIMARY CABLE . . . 3

- Center Conductor . . . 3
- Dielectric . . . 5
- Shield Conductor . . . 5
- Shield Tapes . . . 5
- Electrical Jacket . . . 5
- Loadbearing Strength Members . . . 5
- Polyester Isolation Tape . . . 5
- Subsurface Terminations . . . 5

PROCEDURES . . . 6

STRENGTH TERMINATION . . . 6

- Preparation . . . 6
- Potting Fixture Assembly . . . 11

ELECTRICAL CONNECTOR TERMINATION . . . 21

- Preparation . . . 21
- Assembly and Potting of the Connector . . . 23

APPENDICES

- A. Termination Parts . . . 27
- B. List of Materials . . . 28
- C. List of Fixtures and Tools . . . 29
- D. Solvents and their Uses . . . 30
- E. Urethane Metal Primer Mixing Instructions . . . 31
- F. Use of Nonmetallic Primer . . . 32
- G. Epoxy Mixing, Degassing and Cure Cycle . . . 33
- H. Urethane Mixing, Degassing and Cure Cycle . . . 34

|                                 |   |
|---------------------------------|---|
| ACCESSION for                   |   |
| NTIS                            | White Section <input checked="" type="checkbox"/> |
| DDC                             | Buff Section <input type="checkbox"/>             |
| UNANNOUNCED                     | <input type="checkbox"/>                          |
| JUSTIFICATION _____             |   |
| BY _____                        |   |
| DISTRIBUTION/AVAILABILITY CODES |   |
| Dist.                           | AVAIL. and/or SPECIAL                             |
| A                               |   |

## ILLUSTRATIONS

1. The Remote Unmanned Work System concept . . . 4
2. Cross section of the RUWS primary cable . . . 4
3. Strength termination cone . . . 7
4. Masking and sandblasting the strength termination cone . . . 7
5. Termination stand and scaffold . . . 8
6. Termination stand construction . . . 9
7. Checking the cable lay length . . . 10
8. Wrapping and clamping the cable end . . . 10
9. Assembling the termination fixture . . . 11
10. Cable threaded through scaffold and stand . . . 12
11. Assembling the termination fixture . . . 13
12. Suspending the vacuum chamber . . . 14
13. Kevlar layers unwrapped . . . 15
14. Stringing the elements to the separator ring . . . 16
15. Affixing the electrical lugs . . . 17
16. Termination fixture assembled . . . 18
17. Assembling the mold . . . 20
18. Cutting the cable end . . . 21
19. Cleaning and tinting the shield . . . 22
20. Exploded view of the connector . . . 23
21. Assembled cable and connector housing . . . 25
22. Cable and connector assembly in vacuum chamber . . . 25
23. Preparing connector strain relief . . . 26
24. The final connector . . . 26

## INTRODUCTION

This document describes the procedures for potting and terminating the strength and electrical portions of the primary cable of the Remote Unmanned Work System (RUWS). Also included are lists of tools and materials to be used in the process.

## DESCRIPTIONS

### REMOTE UNMANNED WORK SYSTEM

The RUWS is a major element of the Navy's Deep Ocean Technology project. An unmanned, cable-tethered work system, RUWS is designed to perform a variety of engineering and scientific tasks at ocean depths to 6,100 metres (20,000 feet). It was designed for air transport and operation from specified ships of opportunity. The system includes advanced capabilities for high-accuracy, deep-ocean navigation and local-area bottom search. Figure 1 depicts the RUWS concept.

### PRIMARY CABLE

The primary cable of the RUWS (figure 2) is an electromechanical cable which tethers the submersibles to their control van on the support ship. It consists of a central coaxial electrical cable surrounded by two layers of a contrahelically-wound strength member. The strength member is constructed of Kevlar-49 organic fiber in a matrix of ether-based polyurethane.

Kevlar-49, formerly known as PRD-49, is a recent development of duPont. This new synthetic, high strength/weight material is used as the strength member for the primary cable. The basic fiber is supplied in a multiple filament yarn and is twisted in a polyurethane matrix into strength members which correspond to the individual steel wires in a conventional electromechanical cable.

These new strength members have shown outstanding resistance to flexure fatigue, load cycling and pressurization. Samples have been submitted to over 2,000,000 flexure cycles (20 percent loading) without degradation of tensile strength. Other samples have been soaked and cycled to 10,000 psi (703 kg/cm<sup>2</sup>) in salt water without loss of strength, and with no measurable water absorption. The material showed little or no degradation during 12 months of ocean exposure.

### Center Conductor

The center conductor of the cable consists of 36 wires, each 0.032 inch in diameter, wrapped in left/right/left helices around a 0.032-inch-diameter thermoplastic core. A common lay angle of 17 degrees is used for all helices. The wires are copper, but those in the outer helix are coated with silver to reduce high-frequency resistance. All closed voids are filled with polyethylene grease. The conductor OD is 0.224 inch.

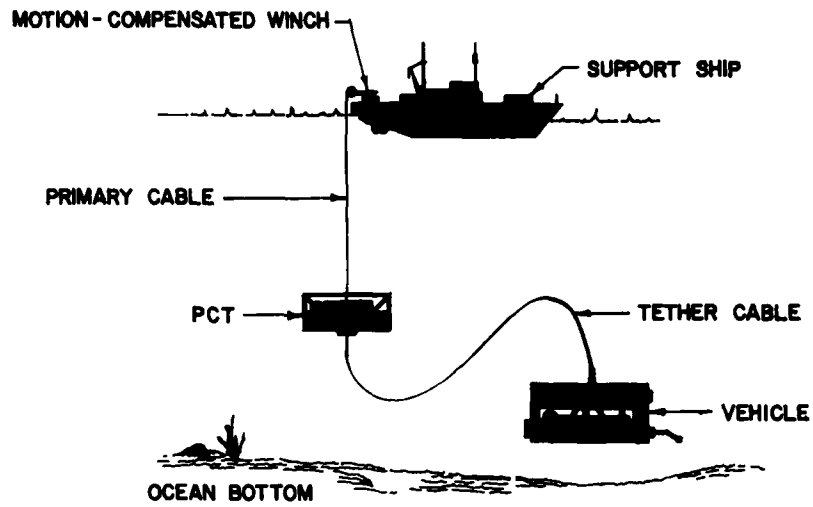

Figure 1. The Remote Unmanned Work System Concept.

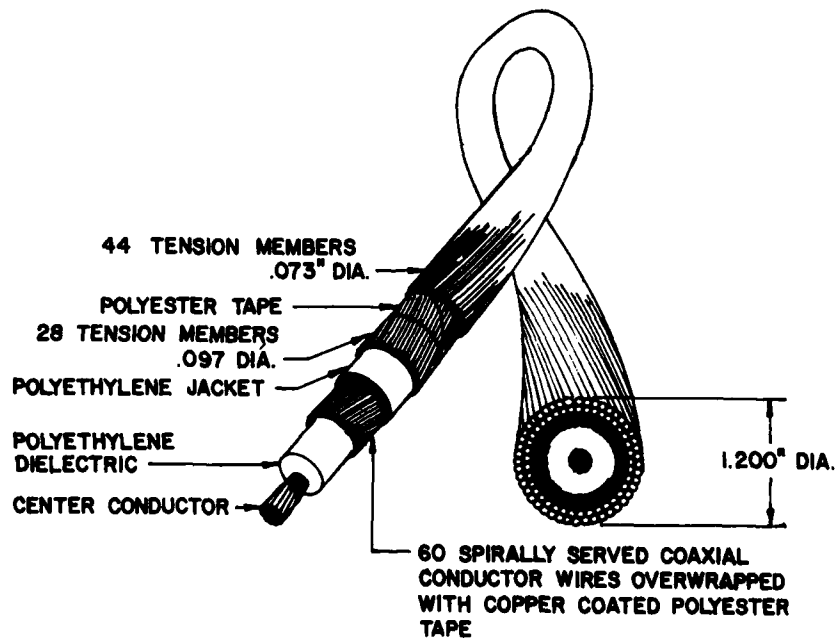

Figure 2. Cross section of the RUWS primary cable.

### **Dielectric**

Low density natural polyethylene is extruded to a diameter of 0.780 inch; then shaved to a final circular diameter of 0.700 inch.

### **Shield Conductor**

Sixty 0.032-inch, silver-coated copper wires are applied as a 31.5-degree, left-hand helix, and voids are filled with polyethylene grease. Design OD is 0.743 inch.

### **Shield Tapes**

To prevent EMI, RFI and crosstalk, a copper-on-polyester tape is wrapped, copper side down, around the shield wires. The wrap consists of 0.0007-inch-thick copper on 0.00092-inch polyester laid directly over the shield wires with a 50-percent overlap and a right-hand lay. An adhesive polyester tape is then applied, left hand, also with a 50-percent overlap.

### **Electrical Jacket**

This is a high-density, black polyethylene applied to provide a final diameter of 0.869 inch.

### **Loadbearing Strength Members**

This is a contrahelix of 72 tension members. Each tension member is constructed as a 1.0-inch-lay, bunched helix of Kevlar-49 filaments in a void-free urethane matrix. The inner cable helix consists of 28 members, each 0.097 inch in diameter, in a 20.6-degree, right-hand lay. The outer helix has 44 members, each 0.073 inch in diameter, in a 14-degree left-hand lay. The design final diameter of the cable is 1.213 inches before any preconditioning operations.

### **Polyester Isolation Tape**

Two 1-mil tapes are applied as a contrahelix spacer between the two Kevlar-49 helices. Each tape is laid with a gap of approximately 0.05 inch between adjacent wraps. This results in a series of diamond-shaped holes which allow seawater to propagate freely among the Kevlar tension members.

### **Subsurface Terminations**

At the Primary Cable Termination (PCT) end of the primary cable, the cable strength members are potted in a stainless steel termination housing. This housing is clamped to the PCT strongback assembly, which provides a gimbaled, shock-mounted termination. Primary cable terminations have been tested to a load that is approximately five times the static loading of the vehicle. PCT and cable when deployed to 6,100 metres (20,000 feet). The electrical portion of the cable passes through the housing and terminates at the PCT signal separator bottle with a special coaxial connector. This plug connector is designed to transmit 40 kW of power at 60 Hz, 3,000 volts and low-level telemetry data in a band from 0.5 to 32 MHz.

## PROCEDURES

The procedures described in this section result in two terminations: the strength termination and the electrical termination. Both terminations are essential.

In the strength termination, the strength termination cone is prepared to receive the epoxy and Kevlar strength members, the termination stand and scaffold are erected, and the cable is stripped back to expose the members to be terminated. The potting fixture assembly is then prepared, and the vacuum chamber is assembled in place. The Kevlar strength members are separated, guided into place in the separator ring, and epoxied into the strength termination cone. Finally, the strength termination strain relief is poured and cured.

Procedures for the electrical termination begin with the cleaning of the pigtail section of the cable jacket, assembling the bulkhead cup and stuffing tube over the cable end, and cutting and tinting of the cable for termination. The connector is then assembled, the cable is assembled to the connector housing, the urethane is poured, and the unit is placed in the vacuum chamber to eliminate bubbles. Finally, the connector strain relief is poured, and the tygon tubing is assembled to the stuffing tube.

This section contains a step-by-step description of the procedures to be followed in these terminations. Refer to appendices A through H for parts, materials, tools and the preparation and use of chemical mixtures.

### STRENGTH TERMINATION

#### Preparation

Before termination can begin, the termination cone, the termination stand and the cable to be terminated must be prepared for the procedure. The steps for each of these preparations follow.

#### Strength Termination Cone

The strength termination cone is shown in figure 3.

1. Mask all areas not to be potted, as illustrated in figure 4.
2. Sandblast all the exposed surface of the cone.
3. Remove all masking tape.
4. Thoroughly clean the cone with solvent (Freon TE-35) to remove all grease, oil and dirt. (Refer to appendix D.)

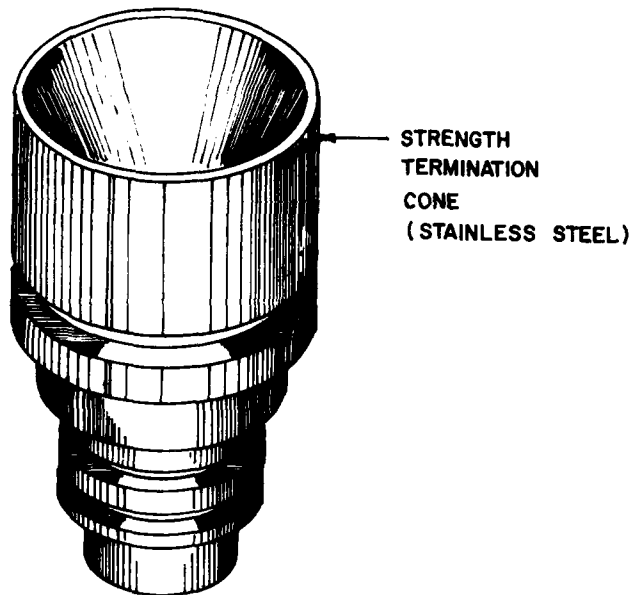

Figure 3. Strength termination cone.

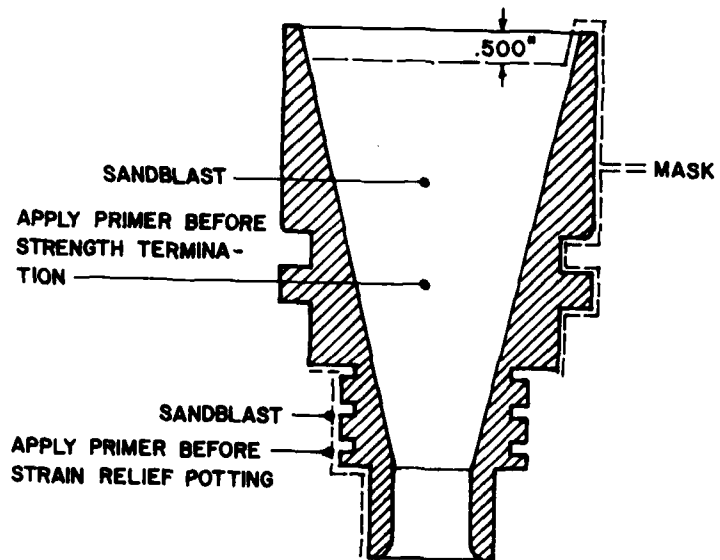

Figure 4. Masking and sandblasting the strength termination cone.

## Termination Stand

A large-radius bend must be maintained on the primary cable during the termination procedure. Therefore, the termination stand should be erected on a platform at least five feet above the floor or deck surface (see figure 5).

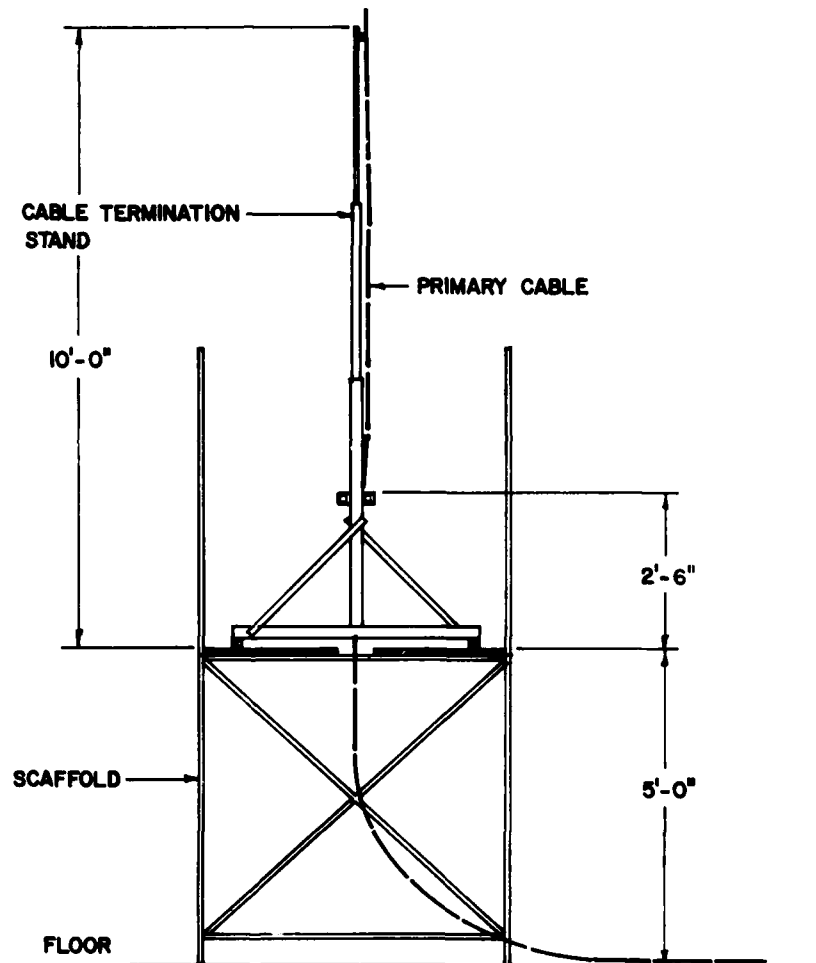

Figure 5. Termination stand and scaffold.

The termination stand (figure 6) is constructed of three sizes of square metal tubing, four feet long, and with 0.375-inch diameter holes on all four sides. Figure 6 indicates which sizes of tubing are used in all parts of the construction. Use 0.375-inch bolts, nuts and flat washers as fasteners.

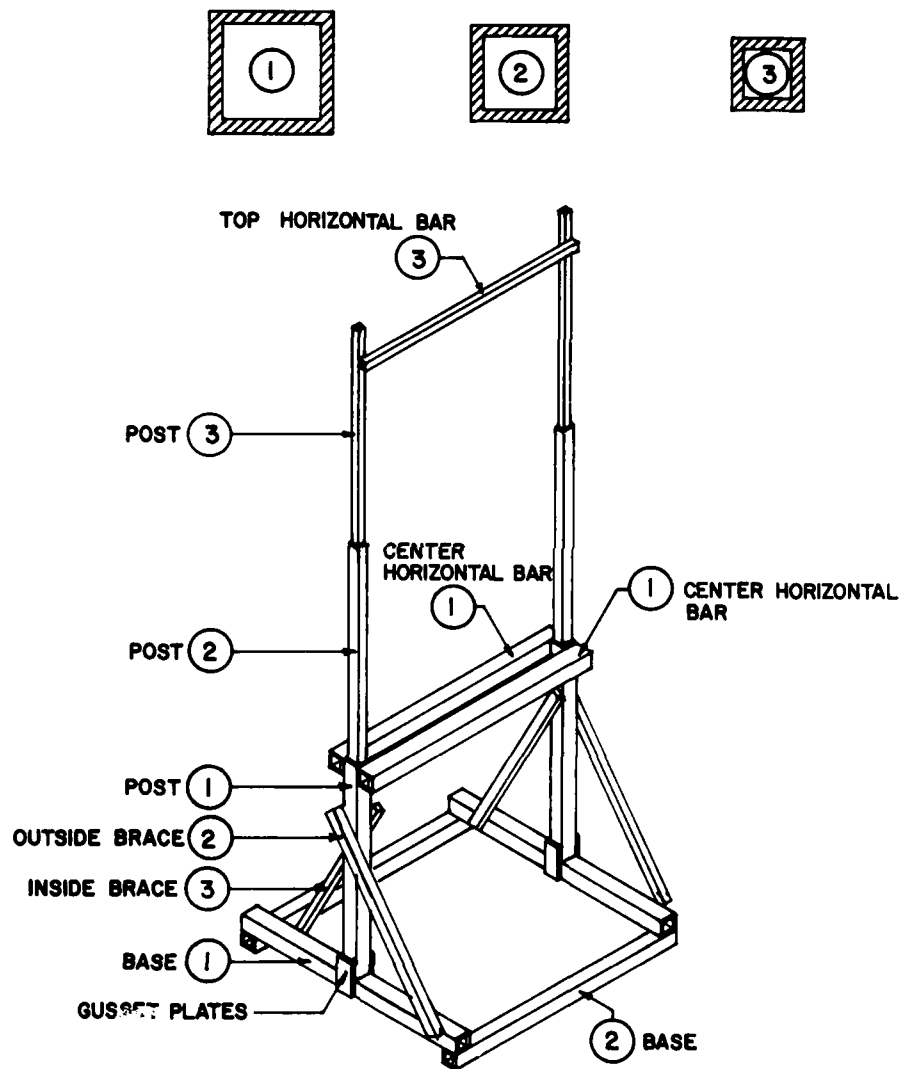

Figure 6. Termination stand construction.

## Cable

1. Remove approximately 50 feet of primary cable from the reel and lay it flat on the deck, free from dirt, oil and grease.
2. Check the lay lengths by measuring between the colored Kevlar strands, as shown in figure 7.

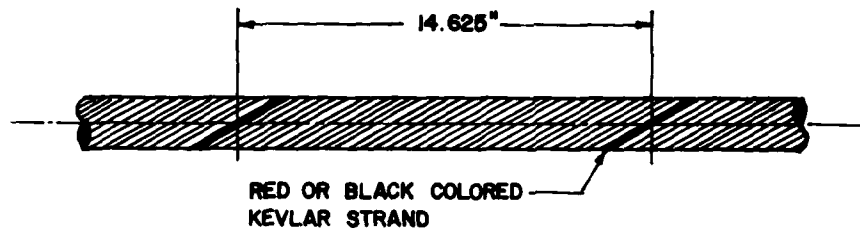

Figure 7. Checking the cable lay length.

3. To keep the lay length in position, the cable must be clamped in several locations. See figure 8.

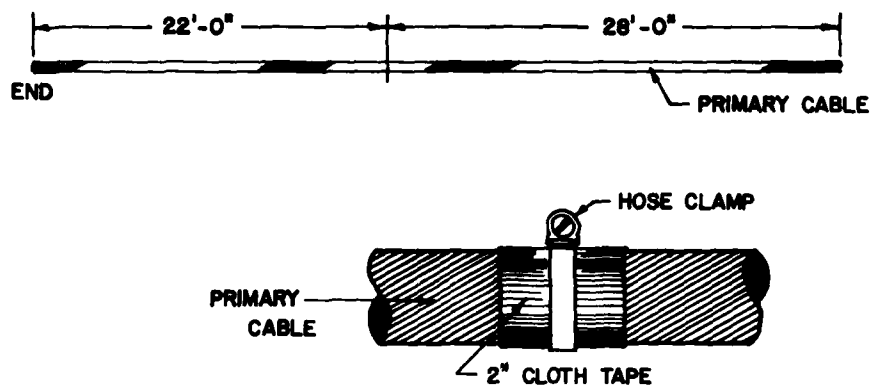

Figure 8. Wrapping and clamping the cable end.

- a. Wrap a piece of 2.0-inch cloth tape around the end of the cable; then install a hose clamp around the tape.
- b. Measure 22 feet from the end of the cable; then install another wrap of cloth tape and another hose clamp at that point.

c. Measuring from the second hose clamp (at 22 feet), install another wrap of cloth tape and another hose clamp every two feet for the next 28 feet of cable.

d. Carefully cut and remove the Kevlar from the first 22 feet of cable. Extreme caution should be exercised not to cut or otherwise damage the black polyethylene coaxial cable jacket.

#### Potting Fixture Assembly

1. Clean and apply metal primer (refer to appendix E) to the strength termination cone.
2. Pass the cable end through the scaffold planking.
3. Pass the cable end through the termination stand at the center double horizontal bars.
4. Pass the cable end through the strength termination cone.
5. Pass the cable end up and over the top horizontal bar, stopping when the end of the Kevlar is 32 inches from the center double horizontal bars.
6. Pass the Kevlar separator ring over the cable end, sliding it over the cable to rest on the strength termination cone (see figure 9).

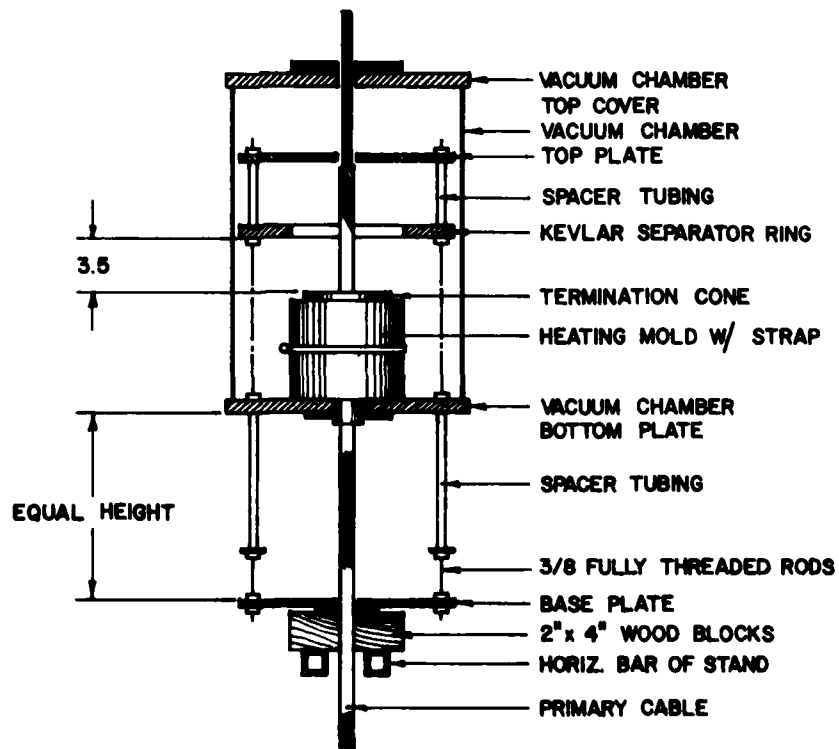

Figure 9. Assembling the termination fixture.

7. Now tie the cable to the top horizontal bar (see figure 10).

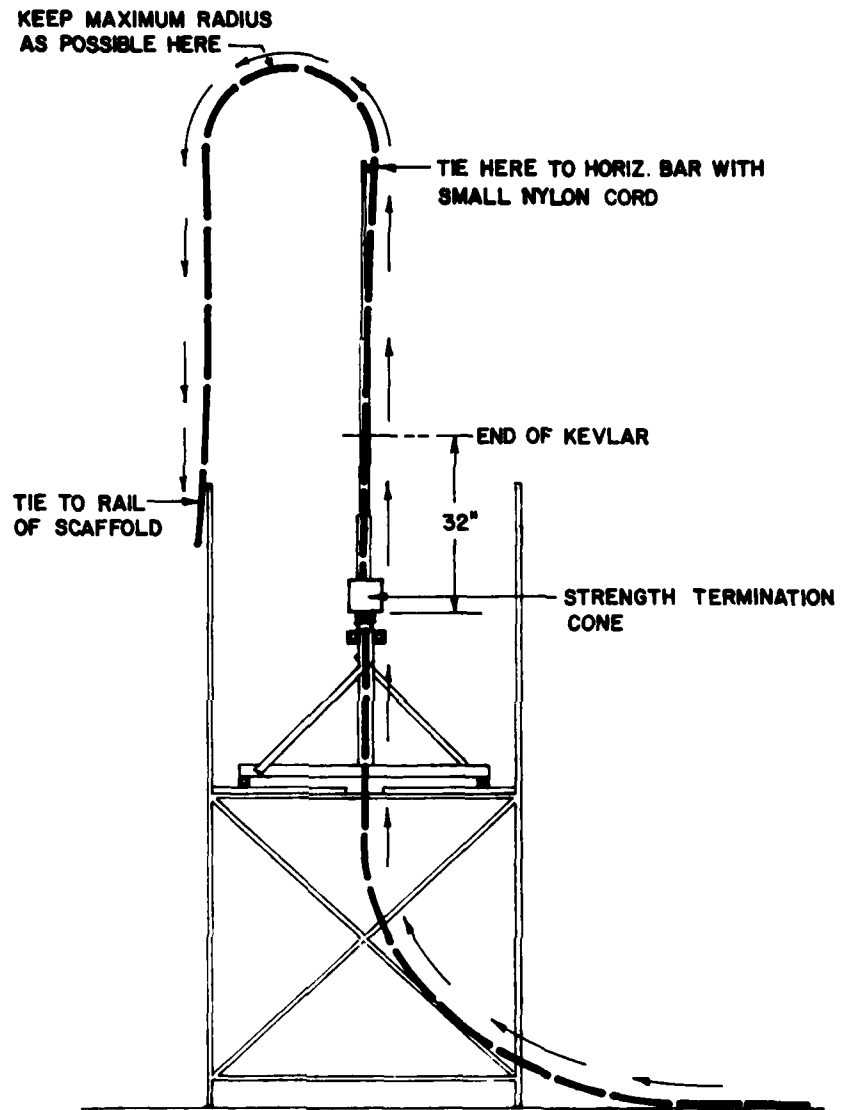

Figure 10. Cable threaded through scaffold and stand.

8. Separate the potting fixture into two halves.

9. Place one half of the potting fixture on the center double horizontal bars.
10. Place the strength termination cone and Kevlar separator ring as shown in figure 11.

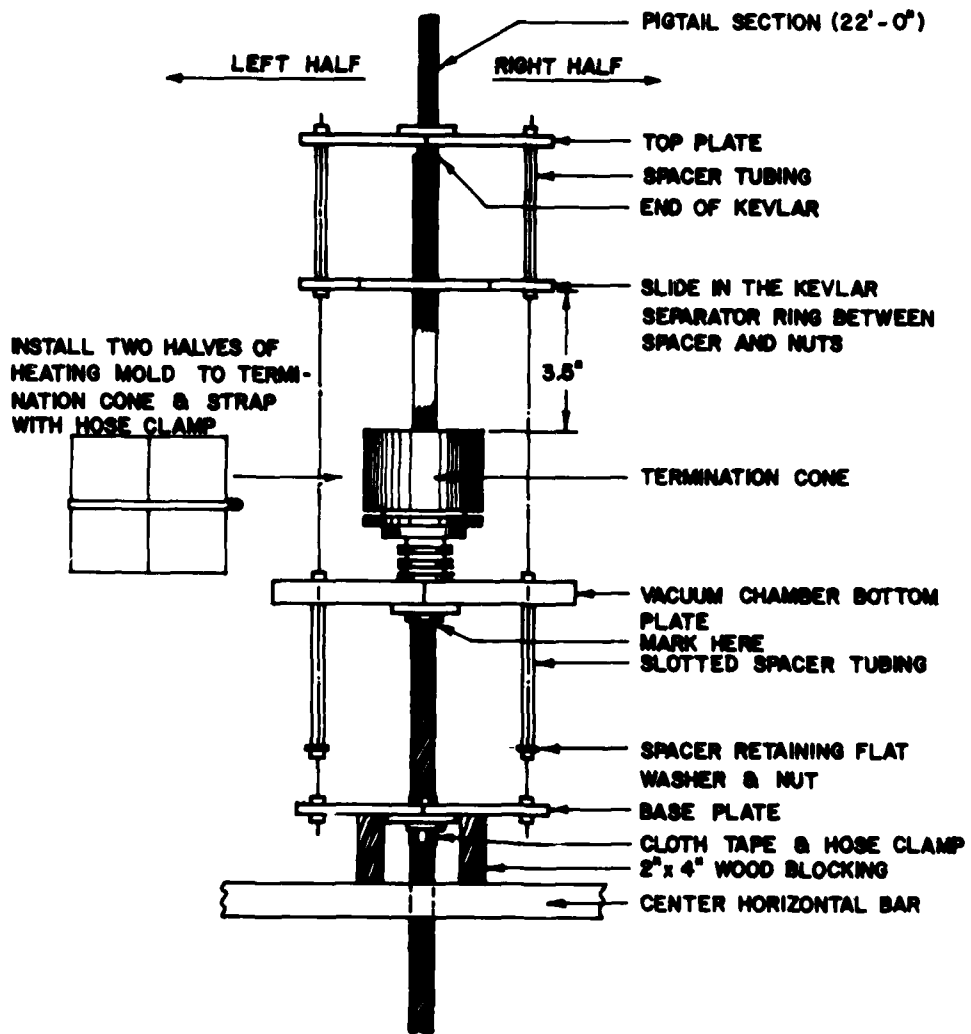

Figure 11. Assembling the termination fixture.

11. Place the other half of the potting fixture on the center double horizontal bars and secure the potting fixture at the top, middle, and bottom plates.

**NOTE:**

Before securing the bottom plate, apply cloth tape at the point at which the plate surrounds the cable. Then, immediately below the plate, apply another strip of cloth tape and another hose clamp to maintain the lay length.

12. To stabilize the fixture, place two 2-inch X 4-inch blocks, 8 inches long, between the bottom of the fixture and the center double horizontal bars as blocking.

13. Slide the vacuum chamber onto the cable end, loosening the tie at the top horizontal bar to let it pass; then retying the cable to the top horizontal bar.

14. Place the vacuum chamber over the fixture.

15. Using the same method, slide the vacuum chamber top cover onto the cable end and place it on the chamber.

16. Check the vertical alignment of the fixture, adjusting the tie accordingly at the top horizontal bar.

17. Suspend the vacuum chamber with ties, as shown in figure 12.

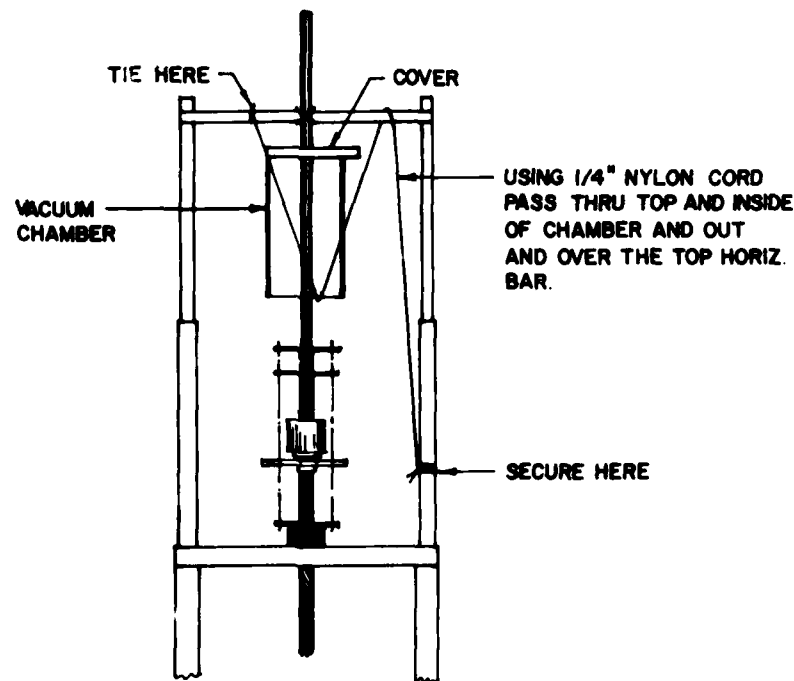

Figure 12. Suspending the vacuum chamber.

18. Place a mark below the middle plate, as shown in figure 11.
19. Loosen the slotted spacer tubing retaining nuts (see figure 11) and remove the spacers. Then slide the middle plate with termination cone downward.
20. Unwind both wraps of Kevlar down to the mark, as shown in figure 13.

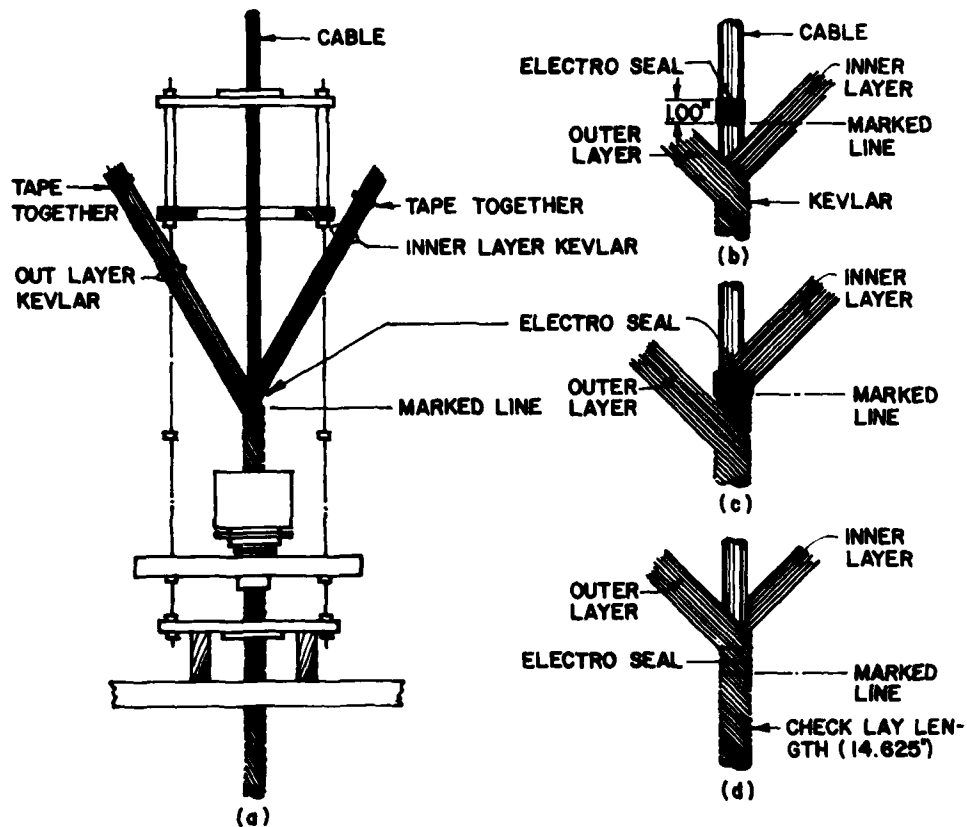

Figure 13. Kevlar layers unwrapped.

21. Separate the outer and inner layers of Kevlar; then apply electro seal between the inner wrap and the center conductor, between the two layers of Kevlar, and on top of the outer layer. Finally, apply electro seal between the outer layer of Kevlar and the relaid jacket.
22. To ensure that the cable has not been disturbed past the mark, recheck the lay angle in accordance with figure 13.

23. Begin stringing the Kevlar elements to the separator ring, inner wrap first. Be certain to maintain the proper lay angle from the cable to the ring. The elements of the inner wrap should be attached to the separator ring 8.5 inches from the point at which they come off the center conductor. The elements of the outer wrap should attach to the separator ring 10 inches from the point at which they come off the cable. (See figure 14.)

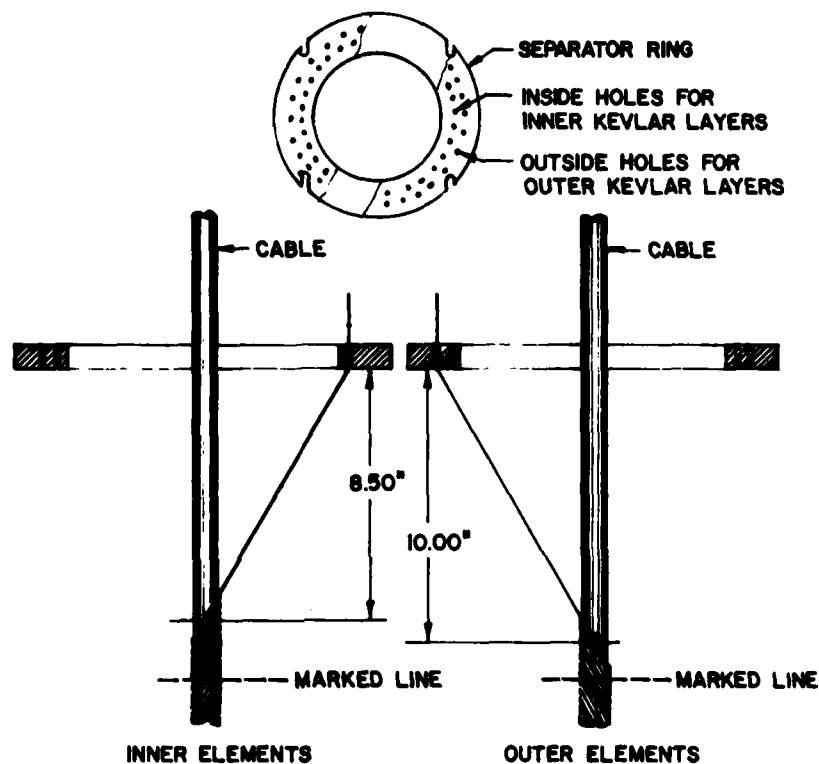

Figure 14. Stringing the elements to the separator ring.

24. Affix a crimp-type electrical lug on the end of each element, as shown in figure 15. Be certain to position the elements in the separator ring so that each element comes off the cable straight to the ring, with no bend as it comes off the cable. During the separation of the elements, avoid any crossover of the elements.

25. Carefully clean the elements between the mark and the separator by wiping them with a soft cloth.

26. Push the middle plate and cone upward and install the slotted tube spacer securely in place.

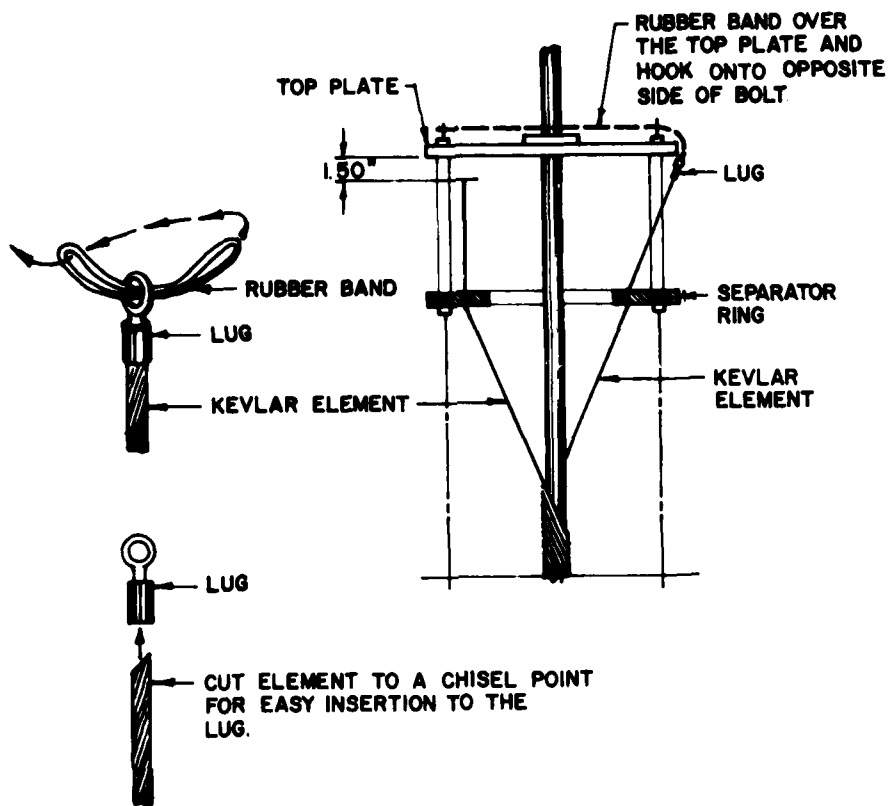

Figure 15. Affixing the electrical lugs.

27. Ensure that the distance between the top of the cone and the separator ring is 3.5 inches, in accordance with figure 11.
28. Install heaters in the heating mantle, setting the control for 150 degrees F.
29. Seal the bottom of the plate with electro seal, as shown in figure 16.
30. Mix 100 grams of PRC-1590 urethane and vacuum all trapped air from the mix. (Refer to appendix H.)
31. Pour the mix into the cone until the level is 4.7 inches from the top edge of the termination cone.
32. Remove the heater elements and sensor from the heating mantle.
33. Lower the vacuum chamber, connect the vacuum pump, and cycle the vacuum several times from minimum to maximum to remove trapped air from around the elements.

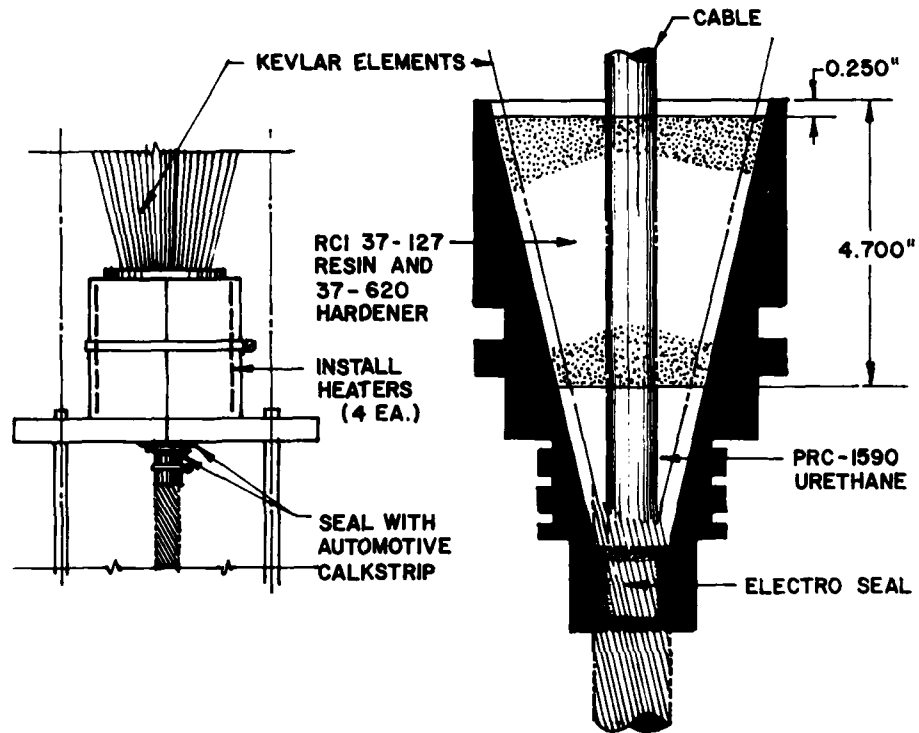

Figure 16. Termination fixture assembled.

34. Raise the vacuum chamber above the fixture, replace the heating elements, and cure for at least eight hours at 150 degrees F or until the urethane has set.
35. Remove the heaters and cool the cone.
36. Pour the socket full of trichlorethylene or Freon TE-35.
37. Remove the rubber band bolts (see figure 15) and relax the tension on the Kevlar elements.
38. Use a circulating pump to agitate the solvent within the socket. Change the solvent often until the elements are soft and free from urethane.

39. If trichlorethylene has been used, remove it and replace it with Freon TE-35. Agitate again. Change the freon two or three times; then remove and let air evaporate the freon from the Kevlar fibers. The fibers must be supple, not stiff.
40. Place the vacuum chamber over the socket and pump to a minimum of 14 psi for approximately 45 minutes to remove all solvent.
41. Mix 520 grams of 100/40 RCI 37-127 resin and 37-620 hardener. (Refer to appendix G.)
42. Evacuate the air and pour the mixture into the socket until the level is 0.5 inch from the top rim of the socket.
43. Evacuate the air from the socket.
44. Allow the resin to cure at room temperature (65-85 degrees F) until the resin becomes rubbery; then heat to 150 degrees F for five hours.
45. Allow the socket to cool.
46. Remove the rubber bands and cut off all elements flush with the resin surface.
47. Disassemble and remove the removable parts of the fixture. Untie the center conductor from the top horizontal bar and lower the termination cone, resting it on the center double horizontal bars; then remove the remaining parts of the fixture.
48. Hold up the termination cone and disassemble the center double horizontal bars; then carefully lower the cone and pigtail section of the center conductor through the scaffold. Lay it flat on the deck.
49. Check the outer lay for looseness and remeasure the lay length (see figure 7).
50. Check the center conductor for any movement out of the socket.
51. Hold the cable to prevent sharp bending and, using the winch on the Motion Compensation Handling System (MCDHS), draw the cable back into the MCDHS boom head until the bottom of the termination is approximately 40 inches from the side rollers in the boom head saddle. Allow approximately 36 inches from the end of the cone to the deck.
52. Clean the cable for about 26 inches from the cone neck with Freon TE-35.
53. Clean the cone neck portion of the socket to be potted, apply metal primer and let it dry. (Refer to figure 4 and appendix E.)
54. Wipe the inside of the strain relief mold with silicone grease as a mold release.

55. Assemble the strain relief mold to the termination cone, aligning and bolting the mold together as shown in figure 17.

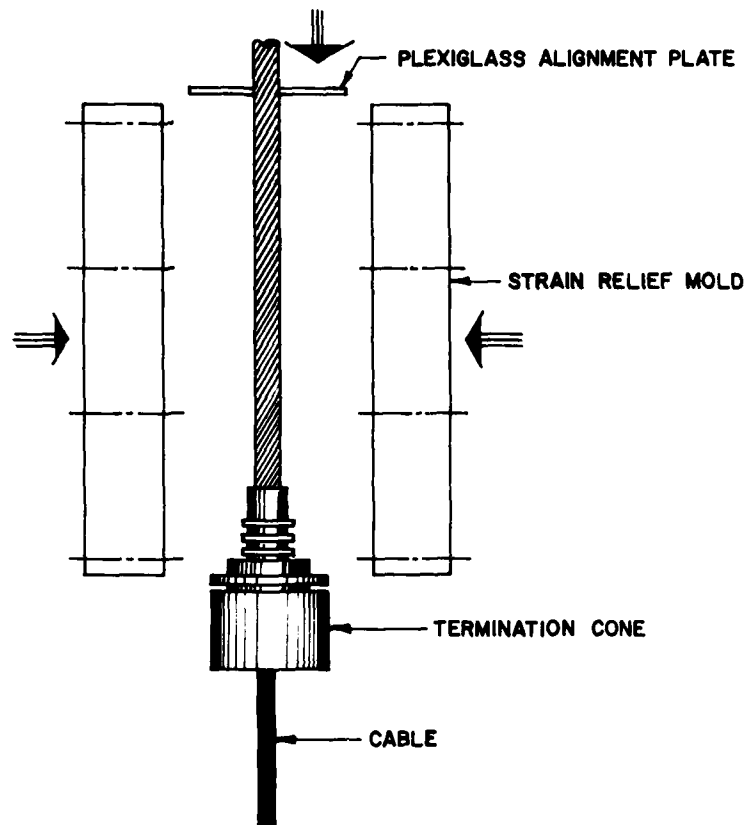

Figure 17. Assembling the mold.

56. Install the two halves of the top plexiglass plates on the mold to hold the cable in the center of the mold.

57. Apply putty around the cone and mold to seal the bottom of the mold.

58. Install six heating elements, connect them to the control, and set the control for 150 degrees F.

59. Using a plastic, one-gallon container, mix two quarts of PRC-1590 urethane (refer to appendix H).

60. Degas the mixture, a little at a time; then pour the urethane into the mold, avoiding entrapment of air bubbles.
61. Cure the urethane for approximately eight hours at 150 degrees F.
62. To ease removal, demold the urethane while it is still hot.
63. Trim as necessary.
64. Inspect strain relief, eliminating any voids or large bubbles with a syringe and needle filled with urethane.

## ELECTRICAL CONNECTOR TERMINATION

### Preparation

1. Clean the pigtail section of the cable jacket with Freon TE-35.
2. Assemble the aluminum bulkhead cup and stuffing tube unit.
3. Pass approximately 10 feet of the pigtail section of the cable through the stuffing tube unit.
4. Place the three-inch tygon tubing on the pigtail section of the cable and insert it into the aluminum cup, securing it with a hose clamp.
5. Measure and cut the end of the cable in accordance with the following steps. See figure 18.

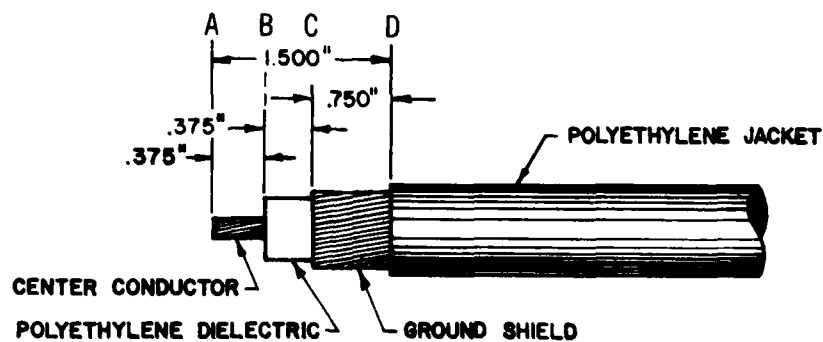

Figure 18. Cutting the cable end.

- a. Mark the required dimensions on the cable.
- b. Using a tube cutter, score the circumference of the cable lightly.
- c. Using the tube cutter, cut line C (see figure 18) down to the dielectric.
- d. Using the tube cutter and a knife, cut line D through the outer jacket, being careful not to damage the ground shield.
- e. Remove the jacket and clean the shield with Freon TE-35.
- f. Wrap a small, stainless steel wire around the ground shield; then tint the shield with soldering lead. See figure 19.

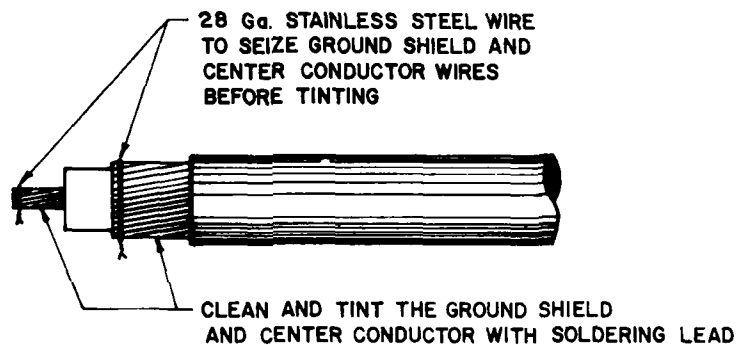

Figure 19. Cleaning and tinting the shield.

- g. Remove the wire; then file the tinted area.
- h. Further smooth the area with sandpaper.
- i. Check the measurement of the exposed dielectric; then remove the polyethylene dielectric with a sharp knife or razor. A twist-and-pull motion in the direction of the wire winding will be the most successful method.
- j. Wrap a small, stainless steel wire around the end tip of the center conductor and tint the conductor.
- k. File the first 0.375 inch of the center conductor; then further smooth it with sandpaper.

- l. Chamfer the tip end of the conductor to facilitate a close fit with the connector pin.
- m. Solder the connector pin to the center conductor and clean away the excess solder.

### Assembly and Potting of the Connector

Figure 20 is an illustrated parts breakdown of the electrical connector. Refer to it for identification.

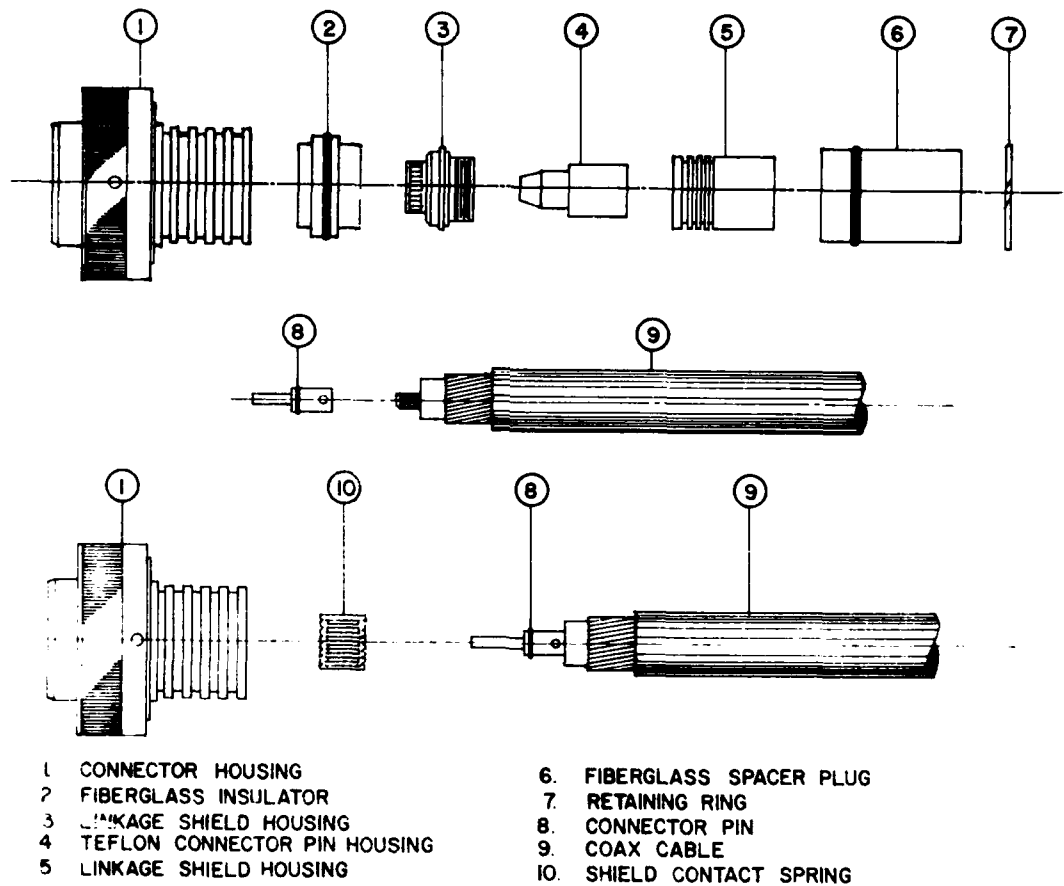

Figure 20. Exploded view of the connector.

1. Insert the teflon connector pin housing into the linkage shield.
2. Check the O-ring and contact spring.
3. Assemble the cable with pin to the connector housing. Ensure that the pin is inserted all the way into the teflon connector pin housing.
4. Check the electrical connection between the center conductor and the ground shield.
5. Mix 100 grams of PRC-1590 urethane. (Refer to appendix H.)
6. Vacuum out any air bubbles which remain in the mixture.
7. Pour the mixture into the socket until the level is 0.25 inch from the top rim of the connector housing. (See figure 21.)
8. Place the connector in the vacuum chamber and evacuate all trapped air from the connector housing. (See figure 22.)
9. Continue filling the housing to its top lip with urethane.
10. Cure the urethane for approximately 16 hours at 150 degrees F.
11. Remove the unit from the vacuum chamber.
12. Sand the polyethylene jacket of the cable with a distance of 4.0 inches from the connector. Clean with Freon TE-35 solvent.
13. Apply nonmetallic primer to the 4-inch area of the cable and let it dry well. (Refer to appendix F.)
14. Prepare the connector strain relief in accordance with figure 23.
15. Mix 200 grams of PRC-1590 urethane. (Refer to appendix H.)
16. Vacuum out any air bubbles which remain in the mixture.
17. Pour the mixture into the mold, as shown in figure 23.
18. Cure the mixture for 16 hours at 150 degrees F.
19. To complete the connector (shown in figure 24), assemble the tygon tube to the stuffing tube.

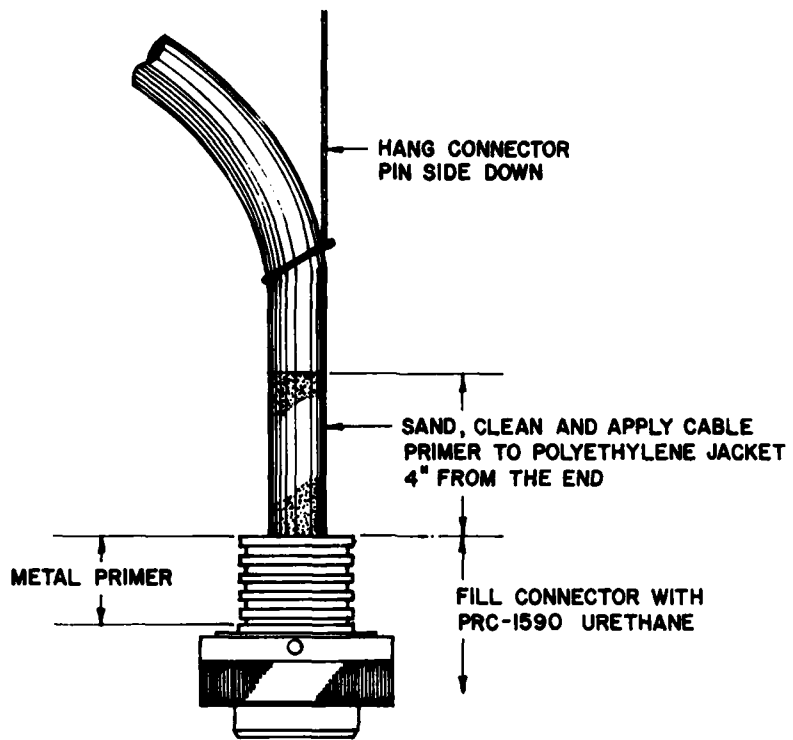

Figure 21. Assembled cable and connector housing.

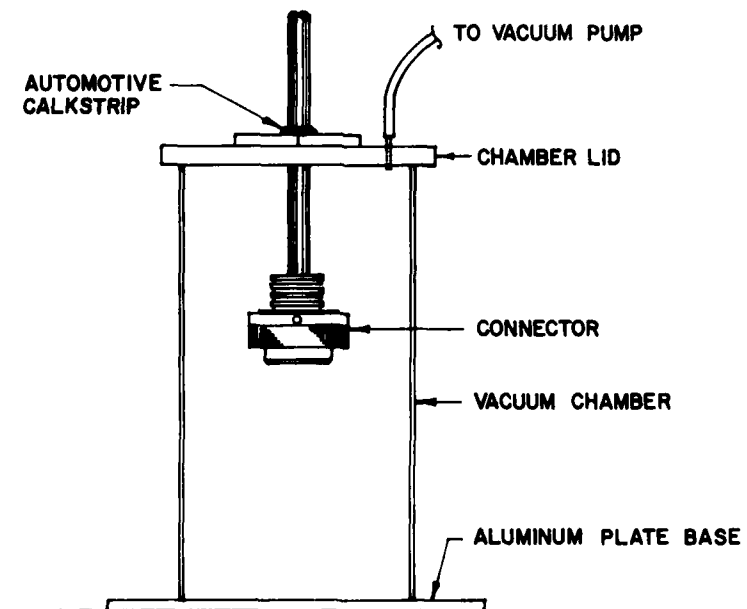

Figure 22. Cable and connector assembly in vacuum chamber.

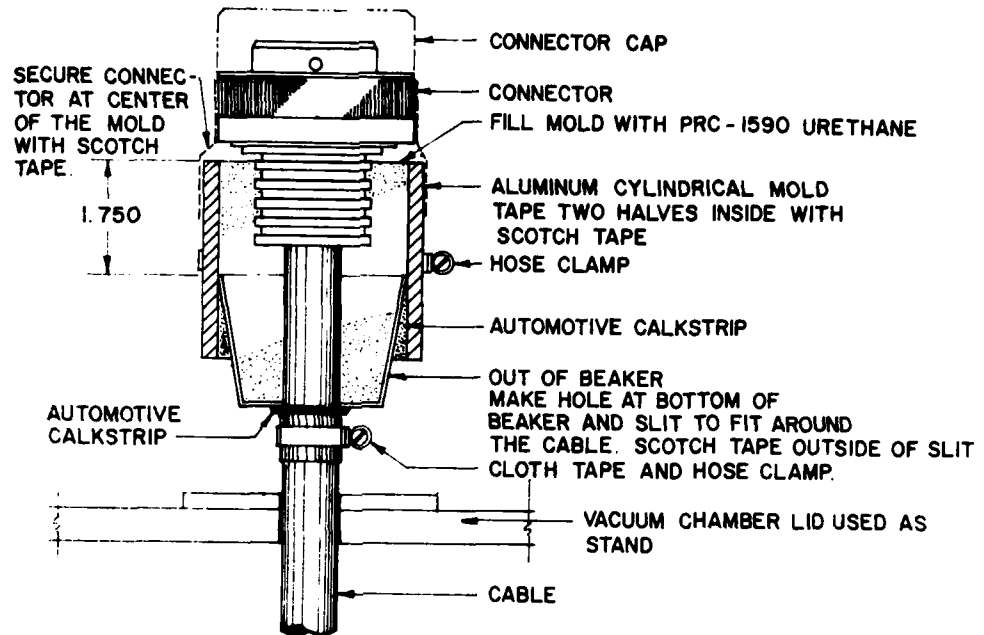

Figure 23. Preparing connector strain relief.

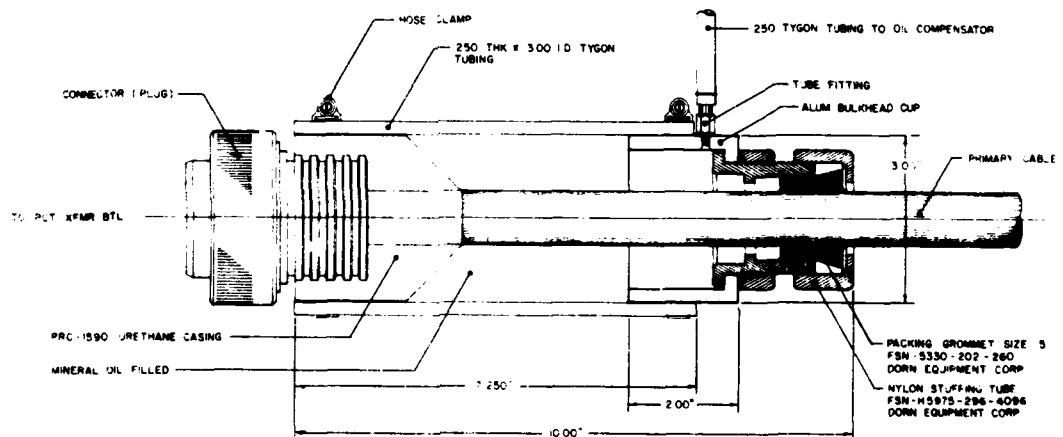

Figure 24. The final connector.

## APPENDIX A: TERMINATION PARTS

The parts listed here are required in order to complete successfully the procedures outlined in this document.

1. Strength termination cone.
2. Electrical connector: Celmark, female contact.
3. Stuffing tube unit: Dorn Equipment Corporation, Size 5.
4. Aluminum bulkhead cup with 0.250-inch tube fitting.
5. Tygon tubing: 0.250-inch thick, 3.0-inch I.D., and 8-inch length.
6. Stainless steel hose clamp: size +48, 3.5-inch.

## APPENDIX B: LIST OF MATERIALS

The materials listed here are required in order to complete successfully the procedures outlined in this document.

1. Urethane, PRC-1590 or PRC-1592.
2. Primers for urethane:
  - a. Metal primer, PR-420;
  - b. Plastic primer, PR-1543.
3. Trichloroethane.
4. Freon TE-35.
5. Acetone.
6. Methyleneethylketone (MEK).
7. Fluorocarbon dry lubricant (mold release).
8. Beakers: 50, 400 and 600 ml.
9. Lint-free paper towels.
10. Acid brushes.
11. Electro seal.
12. Automotive calkstrip.
13. Epoxy:
  - a. Resin: Reichold Chemical, Inc. 37-137;
  - b. Hardener: Reichold Chemical, Inc. 37-620.
14. Masking tape.
15. Cellophane tape: Scotch.
16. Cloth tape.
17. Rubber bands.
18. Electrical lugs.
19. Nylon cord, 0.125- to 0.25-inch.

## APPENDIX C: LIST OF FIXTURES AND TOOLS

The fixtures and tools listed here are required in order to complete successfully the procedures outlined in this document.

1. Sky-tower steel scaffolding with work planks.
2. Roll-about safety ladders.
3. Termination potting fixture stand.
4. Strength termination fixtures:
  - a. Base plate.
  - b. Termination cone receiving plate.
  - c. Bottom spacer tubing.
  - d. Top plate.
  - e. Top spacer tubing.
  - f. Kevlar separator ring.
  - g. Vertical, fully-threaded rods and nuts, 0.375-inch.
5. Bell jar: plexiglass tube.
6. Bell jar top plate.
7. Vacuum pump with 0.250-inch (6.35-mm) I.D. tygon tubing.
8. Termination cone heating mold.
9. Heater.
10. Heater elements.
11. Mixing rods.
12. Injection mold gun with cartridge, cap and tips.
13. Thermometer.

## APPENDIX D: SOLVENTS AND THEIR USES

Freon TE-35 is used to soak the urethane from the strength member elements. In addition, it is used for cleaning in situations where a stronger solvent would cause damage.

Trichloroethane (chloroethane NU or trichloroethylene) is used to remove the void filler compound and some urethane from the strength member elements. Also, it is used for cleaning and degassing. However, caution must be exercised in the latter cases since damage to the conductor insulation can result.

MEK (methyl ethyl ketone) is used for cleaning metal parts before the primer is applied. Its primary use is for thinning the urethane to be used in filling the bubbles.

Acetone is used for cleaning metal parts before the primer is applied. It may be substituted for MEK for cleaning purposes only.

### NOTE

Do not use acetone as a thinner for filling bubbles.

## APPENDIX E: URETHANE METAL PRIMER MIXING INSTRUCTIONS

Material: PR-420 (Products Research and Chemical Corporation).

Thoroughly mix one part of Part A with six parts of Part B by volume. Do not mix more than can be used within a four-hour period.

Brush a thin film of mixed PR-420 on all inside surfaces of connectors and on wire, but not on the insulation. Let the primer dry for one hour at 75 degrees F (22 degrees C).

If the primer becomes contaminated, reclean the primed surface lightly with methylethylketone (MEK) and dry. Stripping the primer from the connector and repriming is not necessary.

## APPENDIX F: USE OF NONMETALLIC PRIMER

Material: PRC-1543 (Products Research and Chemical Corporation).

To obtain good adhesion, the surface should be made tacky with methylethylketone (MEK). Apply a thin coat of PR-1543 to the tackified surface by brush and allow to dry for 30 minutes at room temperature. If primed surfaces become contaminated before potting or molding, buff the primed surface with a suitable abrasive and reapply a thin coat of PR-1543.

## APPENDIX G: EPOXY MIXING, DEGASSING AND CURE CYCLE

Materials: Reichold Chemical, Inc. 37-127 Resin

Reichold Chemical, Inc. 37-620 Hardener

Mix the resin and hardener, using a ratio of 100 parts resin to 50 parts hardener.

Pour the mix into a beaker having at least twice the capacity of the amount of epoxy mixed.

Place the beaker in the vacuum bell jar and evacuate until the mixture begins to bubble. This cycle may have to be repeated several times.

### NOTE

Do not allow the mixture to overflow the beaker. It may be necessary to close off the pump with a valve and allow air to flow back into the bell jar to stop violent bubbling.

When it is possible to maintain a full vacuum on the bell jar and only a few small bubbles remain, the epoxy is outgassed and is ready to be poured into the termination cone.

Epoxy may be cured at 77 degrees F (22 degrees C) for 15 hours, or for 4 hours at 170 degrees F (68 degrees C).

## APPENDIX H: URETHANE MIXING, DEGASSING AND CURE CYCLE

Material: PRC-1590 or 1592 (Products Research and Chemical Corporation).

### HEALTH PRECAUTIONS

PRC-1590 has proven to be a safe material to handle when reasonable care is observed. Ordinary hygienic principles, such as washing the compound from the hands before eating or smoking, should be observed. Hands should be washed with a waterless cleaner, followed by soap and water. Avoid breathing vapors, prolonged contact with the skin, contact with open breaks in the skin, and ingestion.

### MIXING INSTRUCTIONS

#### NOTE

Do not open containers until ready to use.

Part B solidifies when it is kept at temperatures below 65 degrees F (19 degrees C) for prolonged periods. Whenever this condition is encountered, loosen the lid and warm Part B to  $120 \pm 50$  degrees F ( $44.5 \pm 6$  degrees C). When warming the material, use a thermometer to determine the actual material temperature. Liquefaction is complete when the material loses all of its opaqueness and becomes clear. Stirring is essential during liquefaction to provide a uniform material and to hasten melting. After liquefaction, Part B will remain liquid at room temperature.

Part A may solidify partially when stored for prolonged periods below 65 degrees F (19 degrees C). Whenever this condition is found, loosen the lid and warm Part A to  $220 \pm 10$  degrees F ( $102 \pm 6$  degrees C). Do not heat over 230 degrees F (110 degrees C). When warming the material, use a thermometer to determine the actual material temperature. Liquefaction is complete when the material becomes smooth and uniform in appearance and loses all signs of graininess. Stirring is essential during liquefaction to provide a uniform material and to hasten melting.

### DEGASSING INSTRUCTIONS

Pour mixed urethane into a beaker or beakers having two-thirds greater capacity than the amount of urethane mixed. Place the beaker in the bell jar and evacuate it to a maximum of 28.5 in Hg (274 mm Hg). Allow the mixture to foam up and collapse; then continue evacuating until most of the small bubbles have disappeared from the surface of the urethane.

#### NOTE

Do not allow the mixture to overflow the beaker. It may be necessary to close off the pump with a valve, allowing air to flow back into the bell jar to stop violent bubbling.

When most of the small bubbles have been removed, the mixture is ready to be poured into the injection gun tubes.

#### NOTE

Care should be taken to avoid trapping any air bubbles when pouring the mixture into the injection gun tubes.

#### CURE CYCLE INSTRUCTIONS

The urethane must be cured at 175 degrees F (80 degrees C) for 16 hours. Do not cure at a higher temperature, or damage to some materials in the mixture may result.

#### PHYSICAL PROPERTIES AFTER 16-HOUR CURE (PR-1590)

|                               |                                    |
|-------------------------------|------------------------------------|
| Hardness, Shore "A"           | 75                                 |
| Specific Gravity              | 1.08                               |
| Volume Shrinkage (Percent)    | 4                                  |
| Tensile Strength              | 3500 psi (247 kg/cm <sup>2</sup> ) |
| Ultimate Elongation, Die "C"  | 500 percent                        |
| Tear Strength, Die "C"        | 190 lb/in (33.9 kg/cm)             |
| Adhesion Peel                 |                                    |
| Aluminum (Primed w/PR-420)    | 40 lb/in (7.14 kg/cm)              |
| Neoprene (Primed w/PR-1523-M) | 25 lb/in (4.46 kg/cm)              |
| PVC (MEK tackified)           | 28 lb/in (5.00 kg/cm)              |

|  |                    |
|--|--------------------|
| Moisture Absorption (Percent)                                | 2.8                |
| Hydrolytic Stability (MSFC-SPEC-202)                         | Conforms           |
| Flame Exposure   |                    |
| (ASTM D 635: both vertical and<br>horizontal configurations) | Self-extinguishing |