

12

OPTICAL EXCISION PROGRAM

ELECTRONIC CLIPPER

PSI-ER-5538-02

ADA 086913

LEVEL

SDTIC
ELECTE
JUL 21 1980
C

probe

DDC FILE COPY

This document has been approved
for public release and sale; its
distribution is unlimited.

80 6 16 243

11 Jan 80

11

PROBE SYSTEMS, INCORPORATED
655 NORTH PASTORIA AVENUE
SUNNYVALE, CALIFORNIA

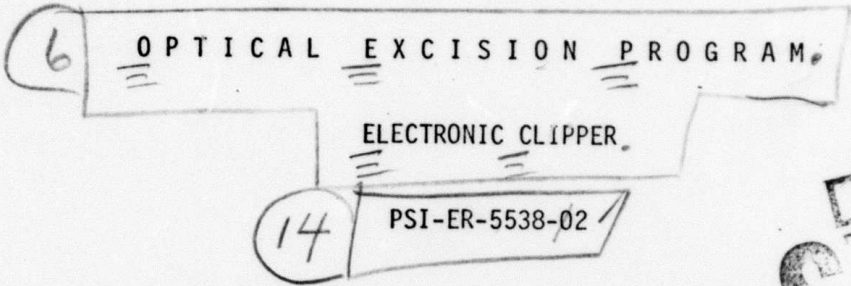

DTIC
EXEMPTED
JUL 21 1980

ARPA Order Number: 3621
 Program Code Number: 8E20
 Effective Date of Contract: 28 December 1978
 Contract Expiration Date: 31 August 1980
 Reporting Period: 1 April 1979 through 31 January 1980
 Contract Number: N00039-79-C-0141
 Principal Investigator: 10 Dave Jackson, (408)732-6550

12 42

9 Rept. for 1 Apr 79-31 Jan 80,

DARPA NAVELEX JOINT PROGRAM
 Sponsored By
 Defense Advanced Research Projects Agency
 ARPA Order No. 3621
 Sponsored and Monitored By
 NAVELEX Under Contract 15 N00039-79-C-0141

WARPA Order-3621

This document has been approved for public release and sale; its distribution is unlimited.

409007 JAW

The views and conclusions contained in this document are those of the authors and should not be interpreted as representing the official policies, either expressed or implied, of the Defense Advanced Research Projects Agency or the U.S. Government.

Accession For

NTIS GMA&I

DDC TAB

Unannounced

Justification *per [unclear]*

By *[Signature]* *26 JUN 80*

Distribution

Approved by [unclear]

Special

TABLE OF CONTENTS

<u>Section</u>	<u>Title</u>	<u>Page</u>
	EXECUTIVE SUMMARY	v
1.	INTRODUCTION	1-1
2.	PRINCIPLES OF OPERATION	2-1
2.1	Coherent Optical Signal Processor	2-1
2.2	Microchannel Plate Photomultiplier	2-3
3.	PERFORMANCE MEASURES	3-1
3.1	DC Characteristics	3-1
3.2	AC Characteristics -- Narrowband	3-3
3.3	AC Characteristics -- Broadband	3-7
4.	CONCLUSIONS	4-1
5.	RECOMMENDATIONS	5-1
5.1	System-Level Developments	5-1
5.2	Detector Developments	5-3
	APPENDIX: SPREAD SPECTRUM TEST SIGNAL GENERATOR AND DIGITAL MATCHED FILTER	A-1

LIST OF TABLES

<u>Table</u>	<u>Title</u>	<u>Page</u>
1	Matched Filter Signal Detections ($\text{SNR}_{in} = -4 \text{ dB}$)	3-14
2	Matched Filter Signal Detections ($\text{SNR}_{in} = \infty$)	3-16

LIST OF ILLUSTRATIONS

<u>Figure</u>	<u>Title</u>	<u>Page</u>
1	Coherent Optical Signal Processor	2-2
2	Microchannel Plate Photomultiplier Tube Structure	2-5
3	Optical Setup for DC Test	3-2
4	MCPMT DC Test Data	3-4
5	Optical Setup for Narrowband Test	3-6
6	Optical Setup for Broadband Test	3-8
7	Electronic Setup for Broadband Test	3-9
8	Input Spectrum for Broadband Test	3-11
9	Output Spectrum for Conventional PMT	3-12
10	Output Spectrum for MCPMT	3-13
11	Probability of Detection as a Function of J/S ($SNR_{in} = -4$ dB)	3-15
12	Output Spectrum with $SNR_{in} = \infty$	3-17
13	Probability of Detection as a Function of J/S ($SNR_{in} = \infty$) . . .	3-18

EXECUTIVE SUMMARY

The ability to significantly reduce the vulnerability of spread spectrum radar communication or intercept systems to narrowband jammer interference has been successfully demonstrated in the laboratory. The interference signal levels were attenuated by the self-adaptive frequency selective limiting properties of an optical processor invented by PROBE SYSTEMS, INC.

The key component in these tests was a standard microchannel plate photomultiplier detector that, when exposed to narrowband signals, would saturate and at the same time amplify low-level broadband signals. This electronic clipping of high power spectral density signals was responsible for the successful demonstration of the feasibility of using a microchannel plate photomultiplier for optical excision of interference.

Experimental results include a test where a simulated spread spectrum radar return with a 20-MHz bandwidth was buried in noise by 4 dB. The detection probability of this signal after passing through a digital matched filter was 40% when the threshold was adjusted for less than a 10^{-6} false alarm rate. When a narrowband jamming signal was introduced at increasingly higher power levels the probability of detection would fall until, for example, at a jammer-to-signal ratio of 9 dB the probability of detection was only 1%. When the optical excisor was inserted just before the digital matched filter the probability of detection rose to 20%. Spectrum analysis showed that the excisor reduced the jammer level by 17 dB, almost down to the receiver noise level.

This feasibility demonstration experiment provides clear evidence of the potential benefits that could be realized by placing an optical excisor in receivers used in broadband radar, communication, and intercept systems. Future investments in the electronic clipper optical excisor should be concentrated on the development of detectors designed to continuously operate at saturation and to conduct system level analytical and experimental investigations. This work would greatly expedite the transfer of optical excision technology to users now faced with increasing complex electronic signal environments.

SECTION 1 INTRODUCTION

This special technical report describes the results of a task conducted by PROBE SYSTEMS as part of a DARPA/NAVELEX Joint Program for Optical Excision. The purpose of this task was to experimentally evaluate the feasibility of using a microchannel plate photomultiplier tube (MCPMT) to adaptively excise narrowband signals from spread spectrum signals. This work resulted in the successful demonstration of an optical excisor with a MCPMT detector used in the front end of a simulated spread spectrum radar operated in the presence of a narrowband jammer. The saturation effects of the MCPMT against the jammer reduced the jammer level by 17 dB and improved the probability of detection from 1% to 20%.

Optical excision is a signal processing technique for eliminating narrowband RF interference signals and has many potential applications in the areas of broadband communications, radar, and intercept systems. This technique uses an acousto-optical Bragg cell and a continuous laser to spatially form the signal spectrum of an electrical input. By blocking strong narrowband interference signals in the optically-generated signal spectrum and by coherently detecting the remainder of the spectrum, an interference-free electronic broadband signal is obtained as the output of the processor. The successful development of optical excisor technology will permit the exploration of a whole family of optical coherent processors that, in real-time, will allow access to the spectrum of a broadband signal.

Considering all of the candidate clippers for use in the coherent processor, the MCPMT offers many advantages. These include automatic operation with instantaneous response to new or intermittent interferers; combination of two functions in one device, i.e., clipping and optical detection of the spectrum; minimal ancillary support equipment; and, as a photodetector, its large active area, wide electrical bandwidth, and compact size.

1. --Continued

The objective of the task reported here was to evaluate the feasibility of using an electronic clipper as an alternative to an optical clipper in the coherent optical signal processor. The technical approach for this experimental effort was to first identify and measure those characteristics of the MCPMT affecting the ability of this device to electronically clip interfering signals. Secondly, a demonstration of excision and a qualitative measure of its effectiveness as a clipper was desired. And finally, measurements were needed that would aid MCPMT manufacturers in the development of a custom tube specifically for the excision application.

This successful demonstration of the feasibility of using a micro-channel plate photomultiplier tube to electronically clip interfering signals has also identified areas that require additional work. These areas are discussed in detail in Section 5, Recommendations. Section 2 describes the principles of operation of the coherent optical signal processor and of micro-channel plate photomultipliers. The tests performed under this task are described in Section 3, Performance Measures, and the test results are presented. Inference drawn from the testing may be found in Section 4, Conclusions.

SECTION 2 PRINCIPLES OF OPERATION

This section of the report describes the principles of operation of the coherent optical signal processor and the microchannel plate photomultiplier tube.

2.1 COHERENT OPTICAL SIGNAL PROCESSOR

The optical excisor, developed by PROBE SYSTEMS, is a coherent optical signal processor with a non-linear element at the Fourier transform plane having the ability to adaptively limit the amplitude of signals in the frequency domain. An understanding of the operation of the excisor requires a description of both the coherent optical signal processor and the non-linear excising element, the clipper.

Shown in Figure 1 is the basic optical processor. The primary components evident in the diagram are the RF input transducer, a Bragg cell; the coherent optical source, a laser; and an output transducer, a large active area optical detector.

The Bragg cell is an acousto-optic crystal with electrical-to-acoustical transducers to convert RF signals into acoustic waves. When illuminated with a laser, the Bragg cell functions as a phase grating and a simple lens pulls the far field diffraction pattern into the focal plane of the lens. This far field diffraction pattern is the Fourier transform of the spatial variations in the Bragg cell. The amplitude of the optical signal spectrum is proportional to the spectrum of the RF input signals. In addition to the frequency to spatial transformation, the diffracted light is Doppler-shifted by an amount equal to the RF input.

When a large area optical detector is placed at the transform plane in the optical processor and illuminated by the signal beam from the Bragg cell

PSI-80050

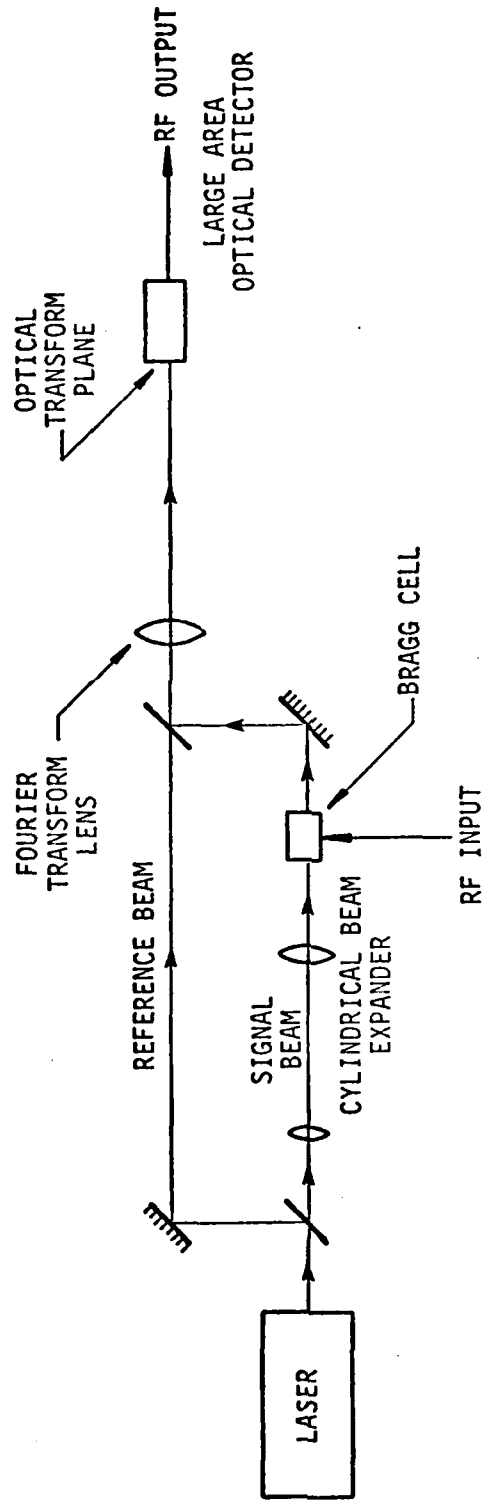

FIGURE 1 COHERENT OPTICAL SIGNAL PROCESSOR

2.1 --Continued

and by a reference beam, heterodyne photomixing occurs. The detector output will be the difference frequency spectrum which is nearly identical to the RF input spectrum in both phase and magnitude.

Excision in this processor can be accomplished by placing a spatial light modulator at the transform plane. By controlling the intensity of each point in the transform, we are able to control the amplitude of the processor output in the frequency domain. For example, a wire mechanically positioned in the transform becomes a notch filter. Photochromic glass (e.g., self-darkening sunglasses) is an example of an auto-adaptive spatial light modulator. These optical clippers spatially modify the optical intensity of the transform.

The clipper that is the subject of this report, the MCPMT, has been named an electronic clipper because the non-linear response of the tube occurs after the generation of photoelectrons. An explanation of the operation of this device completes Section 2.

2.2 MICROCHANNEL PLATE PHOTOMULTIPLIER

The microchannel plate photomultiplier tube was identified by PROBE SYSTEMS in 1977 as being a candidate optical detector having the capability of clipping high level signals in the frequency domain. Because devices are commercially available that have large active areas and bandwidths exceeding 1 GHz, it was felt that they could be placed at the Fourier transform plane of a coherent signal processor to detect the RF spectrum. Since the gain stage of the tube (the microchannel plate) exhibits spatially localized saturation, those frequency components of the RF spectrum at high power levels would saturate those channels and hence be electronically clipped in the frequency domain. Components at lower levels would not cause local saturation and would be amplified in the linear operating region of the tube.

2.2 --Continued

Shown schematically in Figure 2 is the MCP-PMT. It functions in a manner similar to a conventional PMT. In this device, however, electron gain is obtained from the MCP rather than a series of secondary emission dynodes.

The use of microchannels for electron multiplication was first patented in 1930 and it is applied today primarily in proximity-focused night vision devices used by the military. The MCP is a glass disk having millions of short channel electron multipliers of very small diameter (typically 15 microns) packed tightly together into a circular array. Each individual channel is a glass tube that is coated on its inside surface with a high resistivity semiconductor which serves as an emitter of secondary electrons. Both the input and output surfaces of the disk are coated with conductive electrodes and a bias voltage is applied between the two surfaces of the MCP.

The electrodes distribute current to each of the channels and since a current, referred to as the strip current, flows through the resistive coating in the channel walls, a potential gradient exists along the length of the channels just as is the case in a PMT where there is a potential gradient along the dynode string. When an incident electron strikes the interior wall of a channel, secondary electrons are generated, and because of the potential gradient they are accelerated down the channel. These electrons will strike the wall again and more secondary electrons will be generated. This electron multiplication is responsible for the gain in the MCP.

Referring again to Figure 2, photons striking the photocathode generate photoelectrons which are accelerated toward the input surface of the MCP because of the cathode potential. Since the tube is proximity-focused (i.e., photocathode to MCP spacing being very small), those photoelectrons generated at a particular location on the photocathode are focused directly on the MCP. The photoelectrons generate secondary electrons in the channel multipliers which cascade through the MCP and are ejected from the output surface of the plate and are collected on the anode of the tube.

PSI-80051

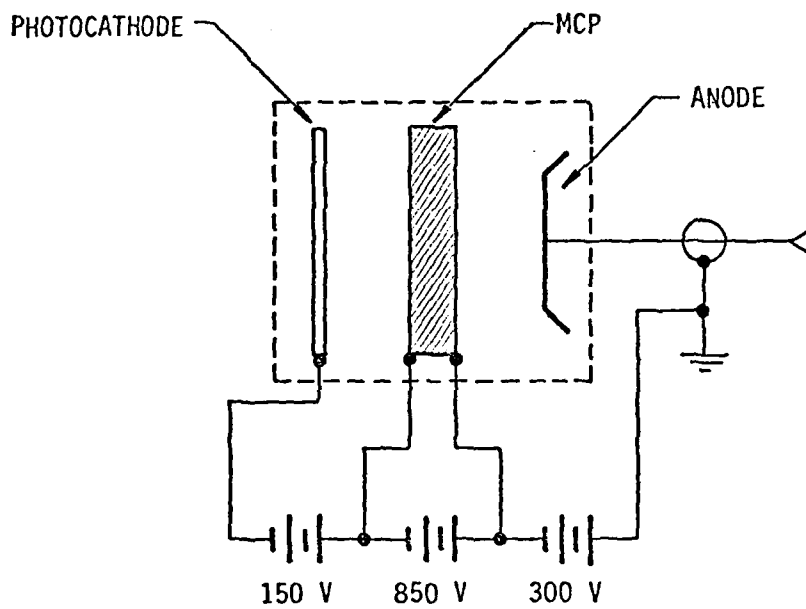

FIGURE 2 MICROCHANNEL PLATE PHOTOMULTIPLIER TUBE STRUCTURE

2.2 --Continued

By examining the gain process that takes place in the channel multipliers of the MCP, it is apparent that there should be some upper bound on the anode current that can flow. It is generally accepted by investigators that the anode current asymptotically approaches the MCP strip current with the linear operating region extending to approximately 5% of the strip current. Because each of the channel multipliers are independent, it is possible to have one or a small cluster of channels in saturation while adjacent channels are still in the linear operating region.

It can be seen that since the input frequency spectrum to the coherent signal processor is represented spatially at the transform plane, each of the frequency components of the spectrum is amplified by microchannel multipliers within the MCPMT. Since these channels can saturate independently, the tube can clip in amplitude each of the high level frequency components of the RF spectrum.

The MCPMT selected by PROBE for the tests described in Section 3 of this report was the F-4126G, manufactured by ITT, Electro-Optical Products Division. This tube has a single proximity-focused channel plate (multiple MCP tubes having higher gain are available), a photocathode with a peak sensitivity at a 500-nm optical wavelength, and an electron gain of 500 at the nominal MCP operating voltages.

Tubes other than the ITT F-4126G were considered, including the Varian VPM 221. Because of the much lower cost, the ITT tube was selected, but the advantage of Varian tubes over ITT is worth noting. Varian incorporates design features that provide longer tube life, particularly when the tube is operated in the saturation region. The principal reason for degradation of MCPMT's is suspected to be the ionization of contaminants in the microchannels at high current densities. These ions tend to collect on the photocathode in ITT tubes and reduce the quantum efficiency. Varian tubes are not proximity-focused because they employ electron optics for focusing and ionized contaminants tend to collect in that structure rather than on the photocathode.

2.2 --Continued

Because it was calculated that the useful life of the ITT tube would be sufficient for the work to be performed under this task, price differential was the dominate factor in the selection of the ITT F-4126G. In systems applications, however, some mechanism for increased tube lifetime will have to be incorporated. Varian tubes already demonstrate enhanced lifetime and ITT indicates they also can incorporate features to provide longer life at high MCP currents.

SECTION 3 PERFORMANCE MEASURES

Tests were conducted to determine the feasibility of using micro-channel plate PMT's in an optical excisor. It was also desired that the tests provide data that could help guide the design of a custom MCP-PMT for the excisor in future applications.

Three kinds of tests were performed: DC, AC-narrowband, and AC-broadband. The DC test sought the tube transfer characteristic -- i.e., optical power in versus current out, and was expected to show the saturation or limiting effects that had been predicted. The second type test performed on the MCP-PMT was the narrowband AC test where two optical beams differing in frequency by approximately 70 MHz were photomixed on the tube. Here, the AC transfer characteristic was sought. The third test was the broadband AC test which was a comparative measure of the enhancement in the detection probability of a spread spectrum signal in the presence of narrowband interference. In this test, data were taken comparing the MCP-PMT with a conventional detector, the Varian VPM-152D.

3.1 DC CHARACTERISTICS

The objective of the DC test was to determine the optical power to output current transfer characteristic of the ITT F-4126G MCP-PMT.

To achieve this objective the optical setup shown in Figure 3 was used. A spatially filtered and expanded beam at 514.5 nm wavelength from an Argon laser was used as the source of illumination. A beam-splitter divided the beam between a laser power and the MCP-PMT. In the optical path to the PMT, neutral density filters were used to attenuate the beam and a 1-mm diameter pinhole was placed close to the MCP-PMT photocathode to limit the area of illumination. Since it was desired that the transfer characteristic data extend well into the saturation region, the 1-mm diameter area of illumination was chosen to minimize the degradation of a larger area of the photocathode. The output current of the MCP-PMT

PSI-80052

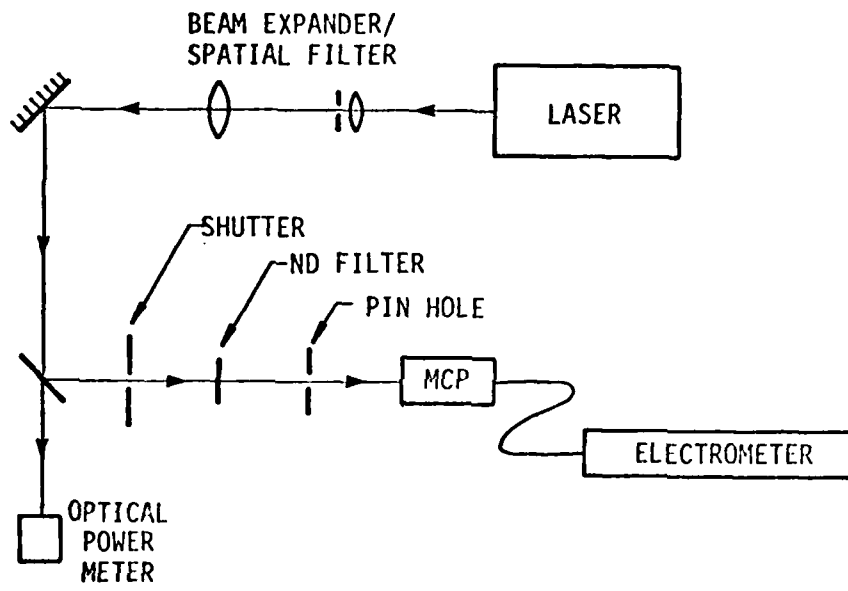

FIGURE 3 OPTICAL SETUP FOR DC TEST

3.1 --Continued

was monitored on a Keithley 610C electrometer and the input optical power on the laser power meter.

The results of this test are shown in Figure 4. Indicated on this plot are lines of constant gain representing responsivities of 30 A/W, 10 A/W, and unity gain. The strip current density, approximately $1 \mu\text{A}/\text{cm}^2$, is also indicated. The effects of dark current summed with the signal current are responsible for the non-linearity seen in the region around an optical flux density of $100 \text{ pW}/\text{cm}^2$. Note that if the area of illumination were larger, the linearity dynamic range would be increased by over two orders of magnitude. Tube gain can be seen to roll off, as predicted, as the output approaches 5-10% of the strip current density. However, as the current reaches I_{strip} it does not level off to a constant current. The tube appears to begin operating linearly at a reduced gain above the strip current level.

This result had not been predicted in the work reported in the literature. It had been known from work conducted by EG&G and others that for very short optical pulses, tubes did exhibit linearity well above the strip current but with non-linearities occurring when total output charge exceeds the charge stored in the channels themselves. For CW illumination the charge model is not valid. Discussions with the tube manufacturer indicated that the only explanation they could postulate for these effects were of thermal origin.

3.2 AC CHARACTERISTICS -- NARROWBAND

The failure of the MCPPMT to saturate was discouraging, but it was decided to measure the bandwidth of the tube at saturation. The hope was that the high levels of current would affect the charge distribution and perhaps reduce the bandwidth so that the response for high frequency signals would be reduced.

The objective of the narrowband AC test was to determine the optical power to RF output power characteristics of the ITT tube. This test was to be

PSI-80053

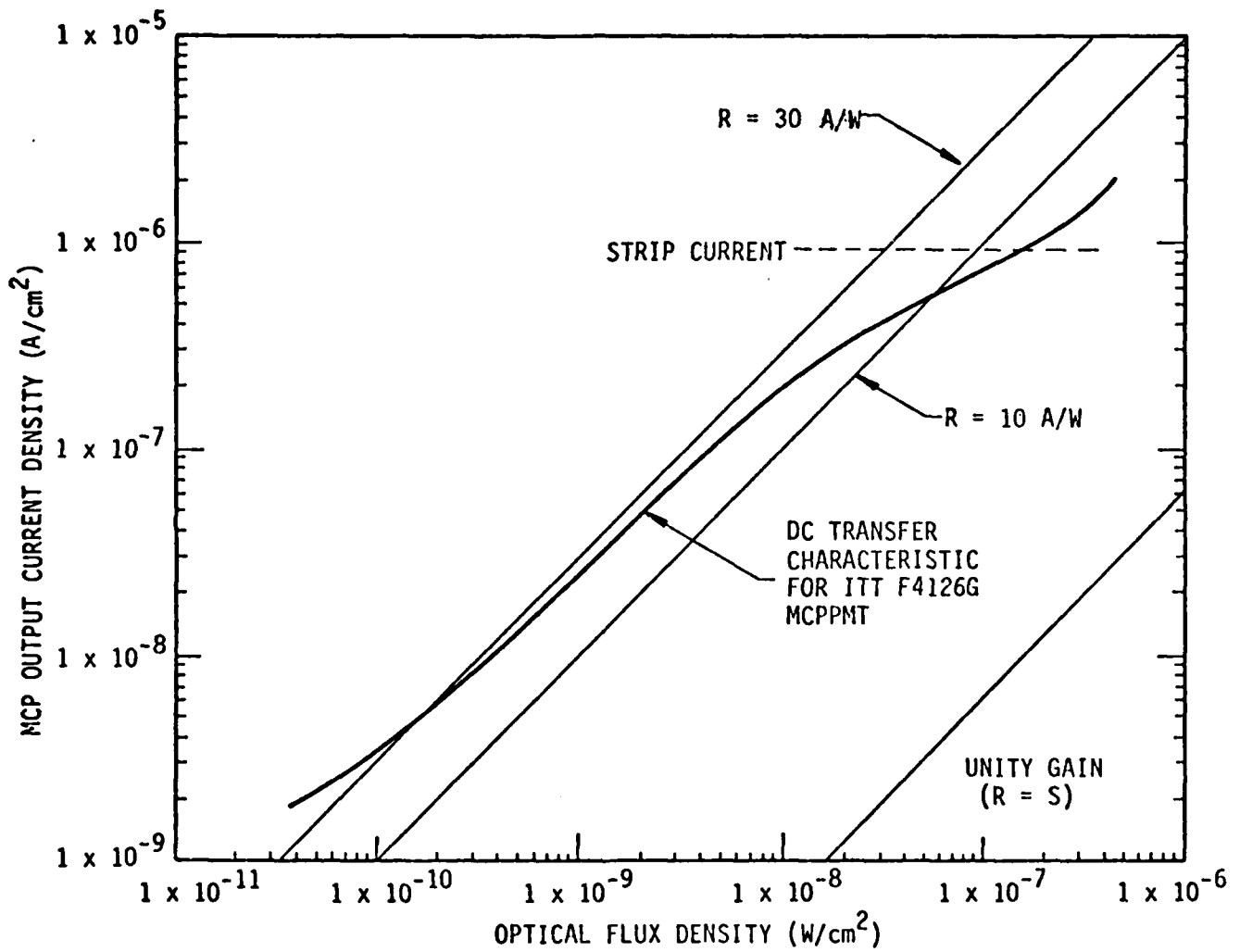

FIGURE 4 MCPPMT DC TEST DATA

3.2 --Continued

similar to the DC test except that the optical input would be the combination of a reference beam and a signal beam shifted in frequency by approximately 70 MHz. The photomixing of these two beams on the photocathode would result in a modulated electron beam which would provide an RF output from the tube. These data would provide insight into the tube's dynamic saturation characteristic.

To achieve this objective an optical test setup in Figure 5 was employed. An Argon laser beam at 514.5 nm passing through a variable neutral density filter was split into two paths: a reference path (optical local oscillator) and a signal path. An acousto-optic Bragg cell placed in the signal path Doppler-shifted this beam. The two beams were then recombined by a second beam-splitter and then expanded/collimated to reduce the optical power density. Expansion and collimation also provided a more uniform wavefront in the two beams, resulting in a high conversion efficiency and 100% depth of modulation in the photomixing process. An aperture in the optical path then limited the beam diameter falling on the MCPPMT Photocathode to a 6.4-mm diameter.

This test gave two important data points: one just below the predicted saturation level of the MCPPMT and one just above saturation. The input optical power level change between the two points was 5 dB, but the change at the output was only 5 dB instead of the 10-dB change that was expected. This indicated that the 70-MHz signal was being compressed.

To verify this, the same experiment was performed without a change in the optical setup except that the Varian VPM-152D PMT was substituted for the MCPPMT. For the same input level change, the Varian tube gave a 10-dB change in the output as predicted.

Because the lifetime of a standard MCPPMT is limited for MCP current densities at or exceeding saturation levels, it was decided to proceed directly to the broadband AC test. The broadband testing would also use a larger area and therefore extend the useful operating region of the tube. The broadband test

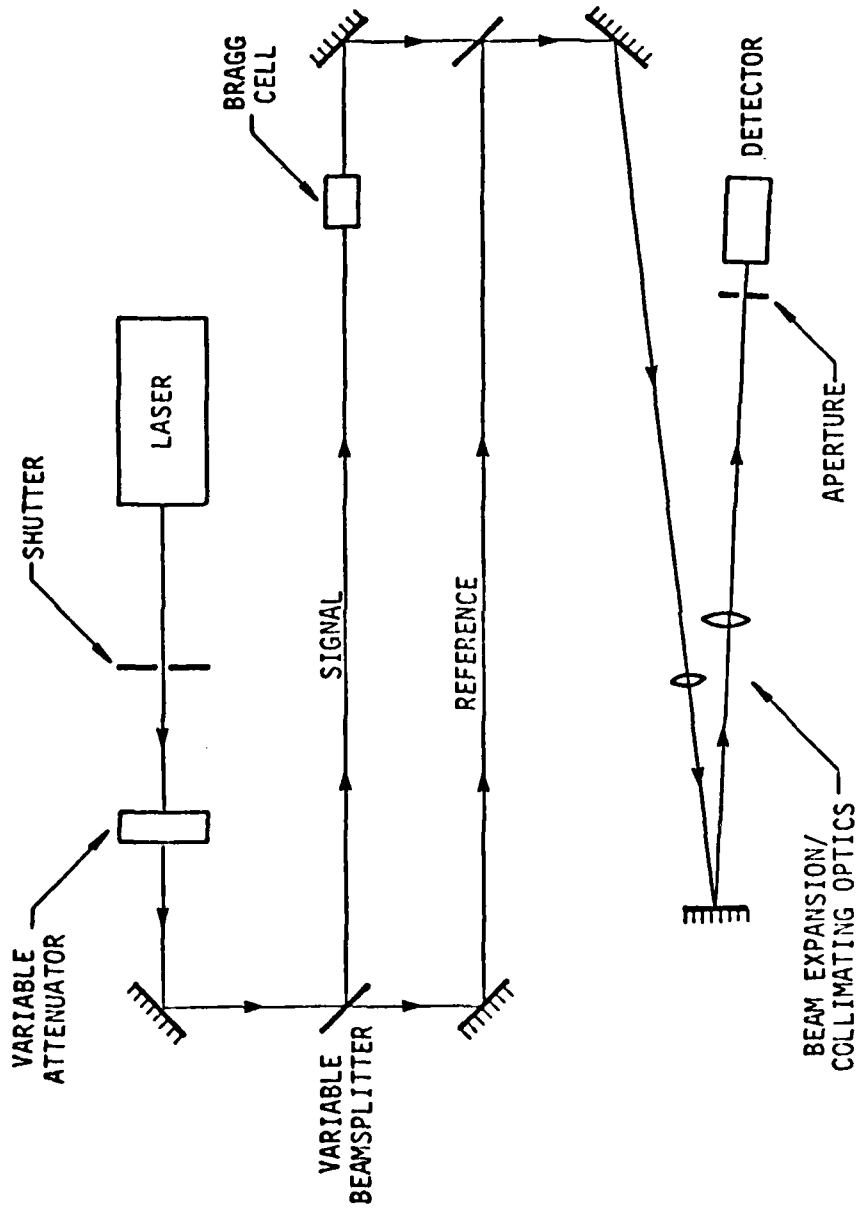

FIGURE 5 OPTICAL SETUP FOR NARROWBAND TEST

3.2 --Continued

would employ a spread spectrum test signal generator and a digital matched filter having 17-dB processing gain. This would result in useful data even when the output signal was below the thermal noise level.

3.3 AC CHARACTERISTICS -- BROADBAND

The objective of the broadband AC testing was to demonstrate excision by the MCPPMT and to measure the improvement in the detection probability of spread spectrum signals in the presence of narrowband interference.

To accomplish this objective, the optical setup shown in Figure 6 was used. This test configuration is similar to that used in the narrowband testing. Here though, a cylindrical beam expander in the signal path fully illuminated the Bragg cell aperture and a transform lens in the combined beam path brought the signal spectrum to focus with nearly 100 cells of resolution. In this setup, the detector's photocathode was placed directly at the transform plane.

A block diagram of the spread spectrum electronics associated with this test is shown in Figure 7 and is described in the Appendix. At the input, a signal from the spread spectrum test signal generator was summed with the output of a VHF oscillator which simulated the interfering narrowband signal. The summed signal was the input to the excisor's electronic package. Also note from the diagram that spread spectrum signal plus interference is summed with the output from a broadband noise generator in the electronics package to simulate receiver noise. After filtering and amplification, the spread signal plus interference plus noise provided the drive input to the Bragg cell in the optical processor.

Signals having been detected in the optical processor were amplified and filtered, then downconverted to baseband in the excisor's electronics. This downconverted output provided the input to the digital matched filter. The detection probabilities and false alarm rate were measured with a frequency

PSI-80055

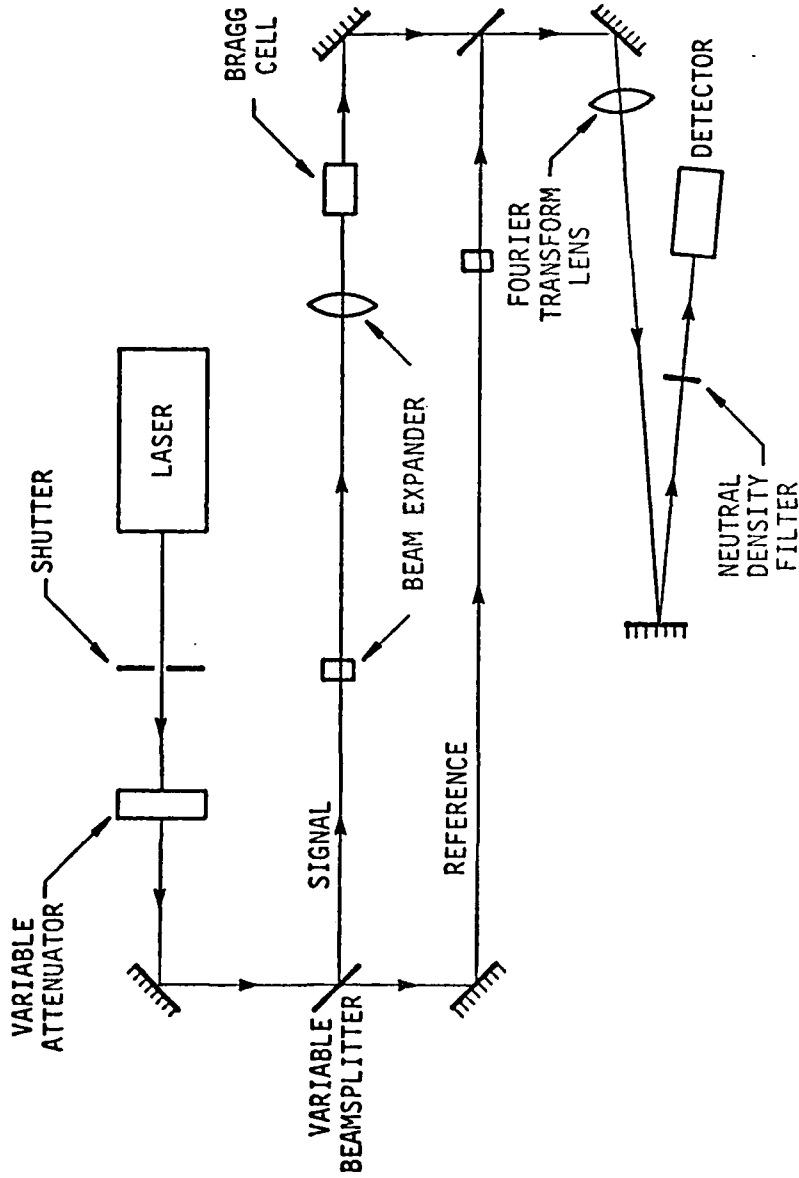

FIGURE 6 OPTICAL SETUP FOR BROADBAND TEST

PSI-80056

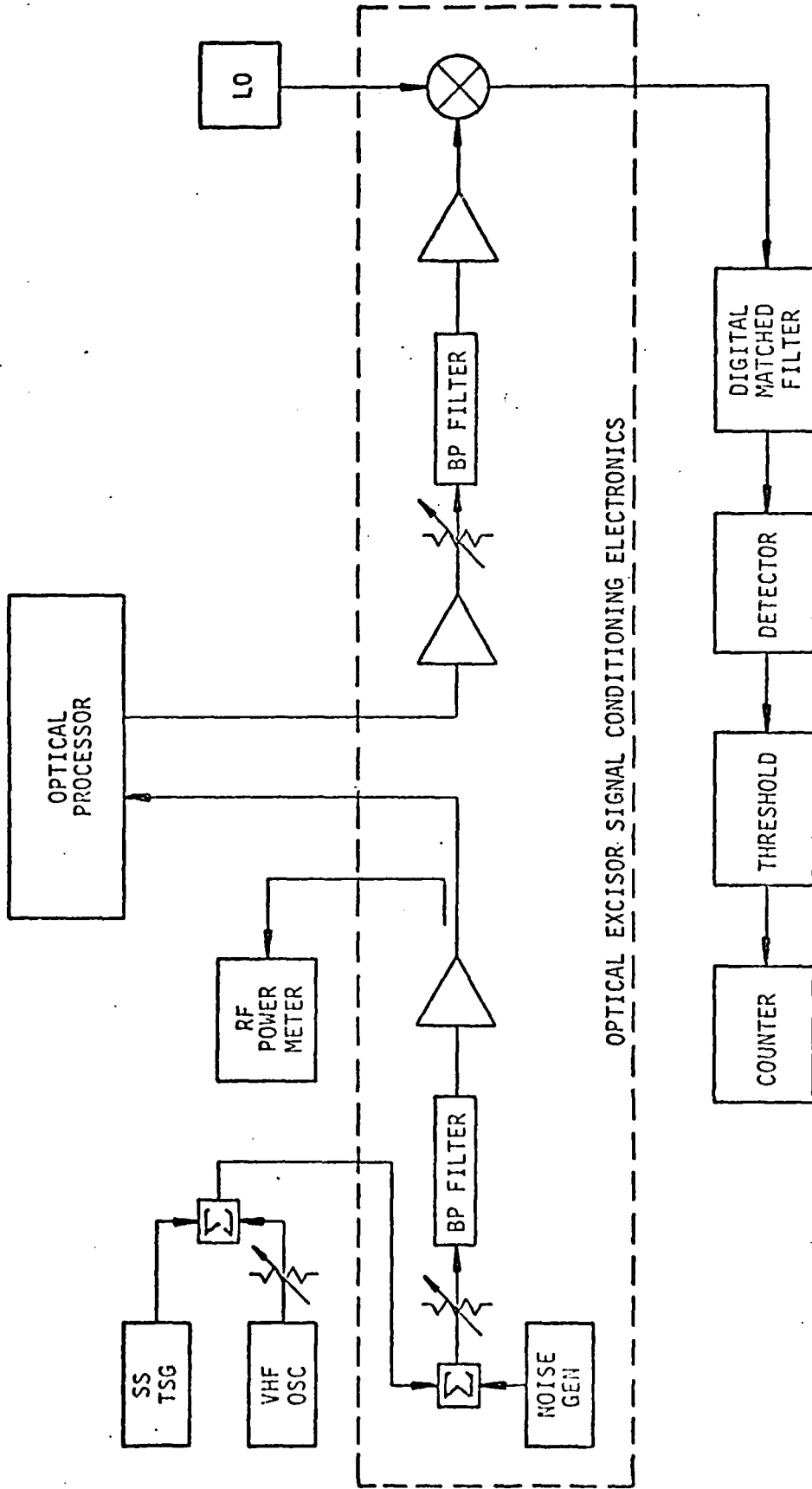

FIGURE 7 ELECTRONIC SETUP FOR BROADBAND TEST

3.3 --Continued

counter. A brief discussion of the matched filter and the process of measuring these parameters can be found in the Appendix.

Broadband AC tests on the MCPPMT resulted in the successful demonstration of excision by an electronic clipper in the coherent optical signal processor. Shown in Figure 8 are a sequence of photographs of the RF spectrum driving the Bragg cell. Figure 8A shows the bandpass-filtered noise spectrum from the internal noise generator, while 8B shows the addition of the spread spectrum signal to the noise at a -4 dB SNR. In Figures 8C and D, an interfering signal at 37.8 MHz has been added to the input. Figure 8C shows just the spread spectrum signal and interferer, and in D the composite Bragg cell drive with noise, spread spectrum signal, and interference are shown. The power of the interference was eight times the total power of the signal and therefore the J/S ratio of the interferer is +9 dB.

In all spectrum photographs shown the settings of the spectrum analyzer were as follows:

IF Bandwidth:	100 kHz
Scan Width:	5 MHz/Div
Scan Time:	1 Sec/Div
Video Filter:	100 Hz

The Varian VMP-152D PMT was used in the optical setup to provide baseline data to which the MCPPMT performance could be compared. In Figure 9, the output RF spectrum is shown for noise (A); noise with the addition of the spread spectrum signal at a -4 dB SNR (B), and the added interference with a J/S of +9 dB (C). This series of output spectrum photographs for the PMT corresponds to the input spectrums shown in Figures 8A, B, and D, respectively.

Replacing the PMT with the MCPPMT, the output spectra shown in Figure 10 was obtained. Comparing Figure 10C with 9C, we see an effective reduction in the amplitude of the interference. Within the analyzer's 100 kHz IF bandwidth there is an observed 17 dB reduction in the J/(S+N) with the MCPPMT.

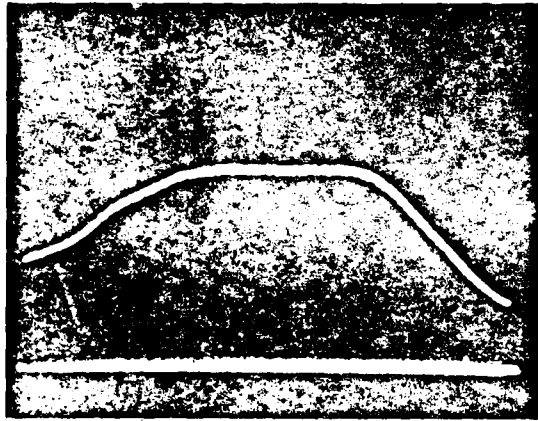

A. INPUT NOISE SPECTRUM

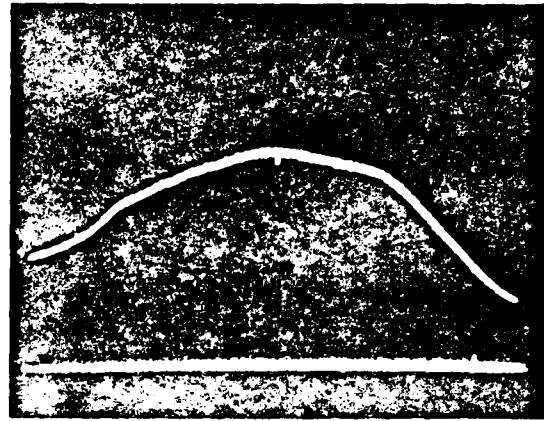

B. INPUT NOISE AND SPREAD SIGNAL
(S/N = -4 dB)

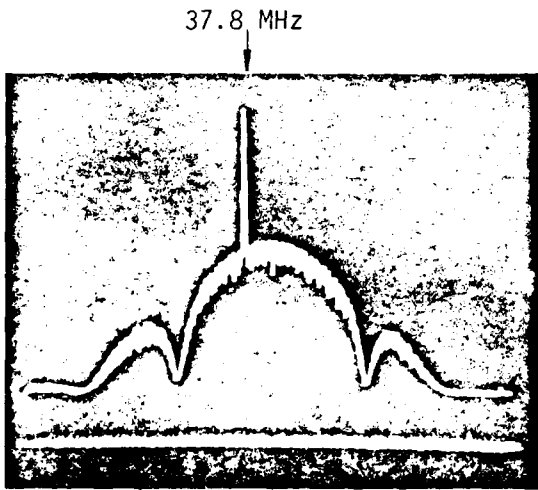

C. SPREAD SIGNAL AND INTERFERENCE
(J/S = +9 dB)

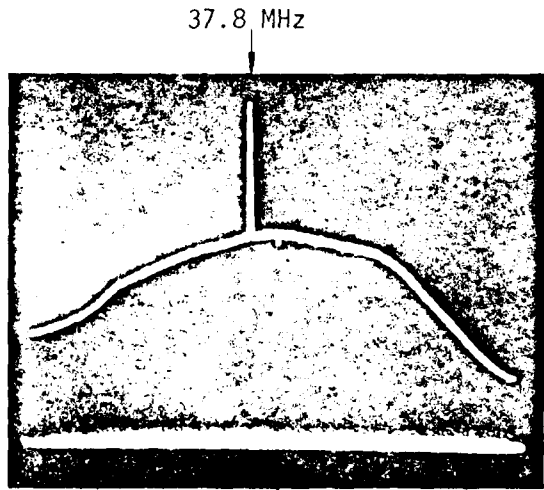

D. INPUT NOISE, SPREAD SIGNAL,
AND INTERFERENCE
(S/N = -4 dB, J/S = +9 dB)

FIGURE 8 INPUT SPECTRUM FOR BROADBAND TEST

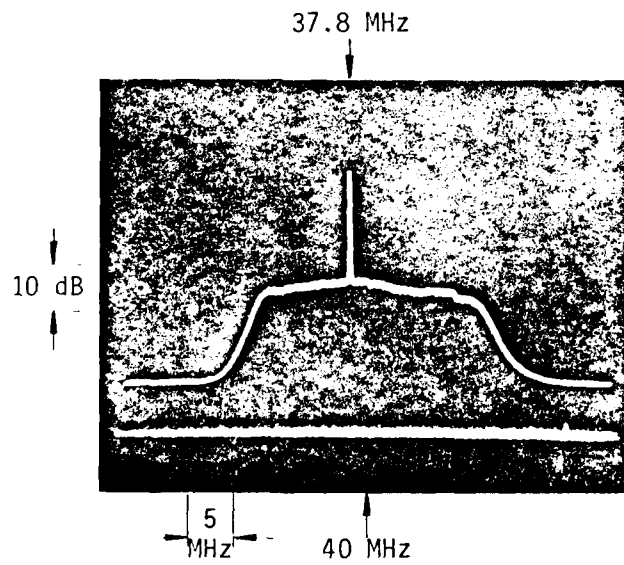
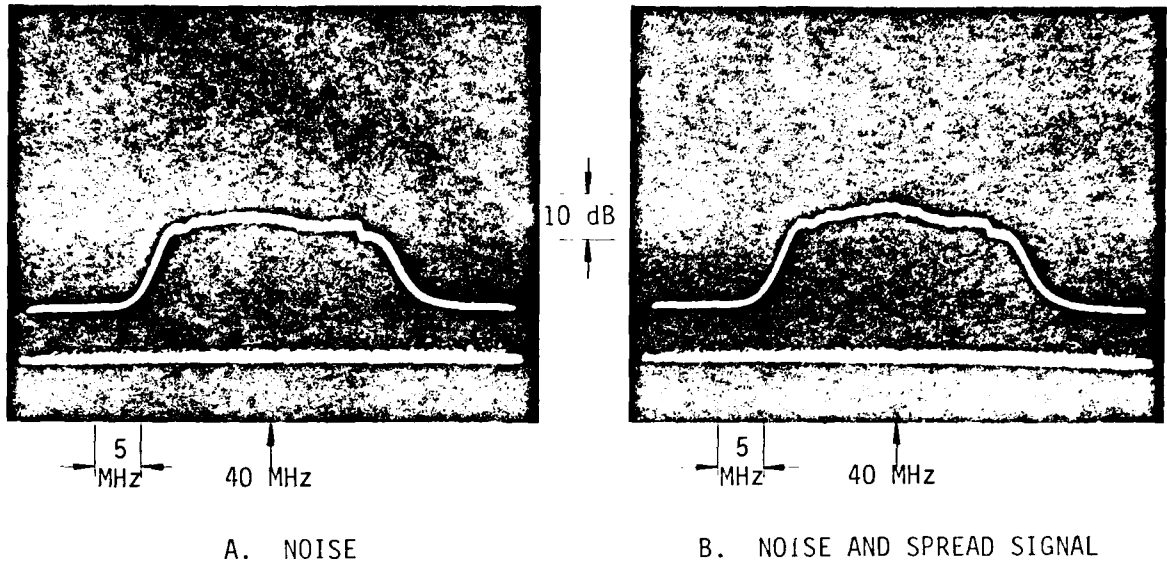

FIGURE 9 OUTPUT SPECTRUM FOR CONVENTIONAL PMT

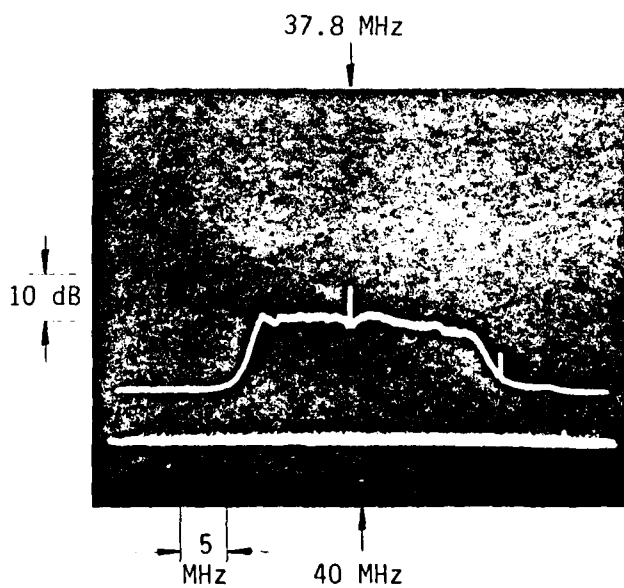
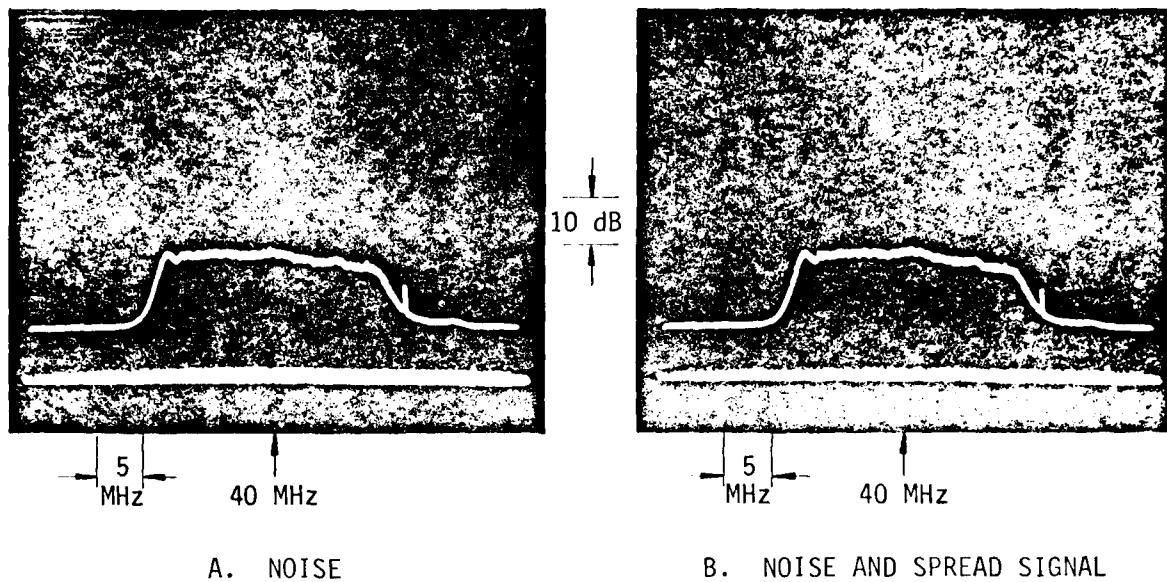

FIGURE 10 OUTPUT SPECTRUM FOR MCPMPT

3.3 --Continued

In addition to the spectral comparison data, broadband measurements with the two detectors were made using the digital matched filter. Table 1 shows the number of detections per second for both detectors as the amplitude of the interference was changed. This data, presented graphically in Figure 11, shows a change in the probability of detection of the signal as a function of J/S for the Varian VPM-152D PMT and the ITT F-4126G MCPMT. As seen in this plot, there is an improvement in the probability of detection using the MCPMT. At a J/S of +9 dB, for example, the P_d with the MCPMT is down from the initial P_d of 40% by a factor of 2. While using the PMT, however, we see the P_d down by a factor of almost 40. Viewing this data from another perspective (i.e., that of constant probability of detection) we see an effective reduction in J/S. For example, at a P_d of 20% and a J/S of +9 dB at the input, there is effectively a 7-dB reduction of the J/S when compared to the conventional PMT.

TABLE 1
MATCHED FILTER SIGNAL DETECTIONS ($SNR_{in} = -4$ dB)

J/S (dB)	N_d (DETECTIONS/SEC)	
	VARIAN PMT	ITT MCPMT
$-\infty$	30,576	30,535
-9	29,143	30,392
-6	27,516	29,133
-3	24,017	27,484
0	20,062	25,838
+3	13,165	23,308
+6	5,162	20,550
+9	807	14,883

$$N_{fa} = 91$$

PSI-80057

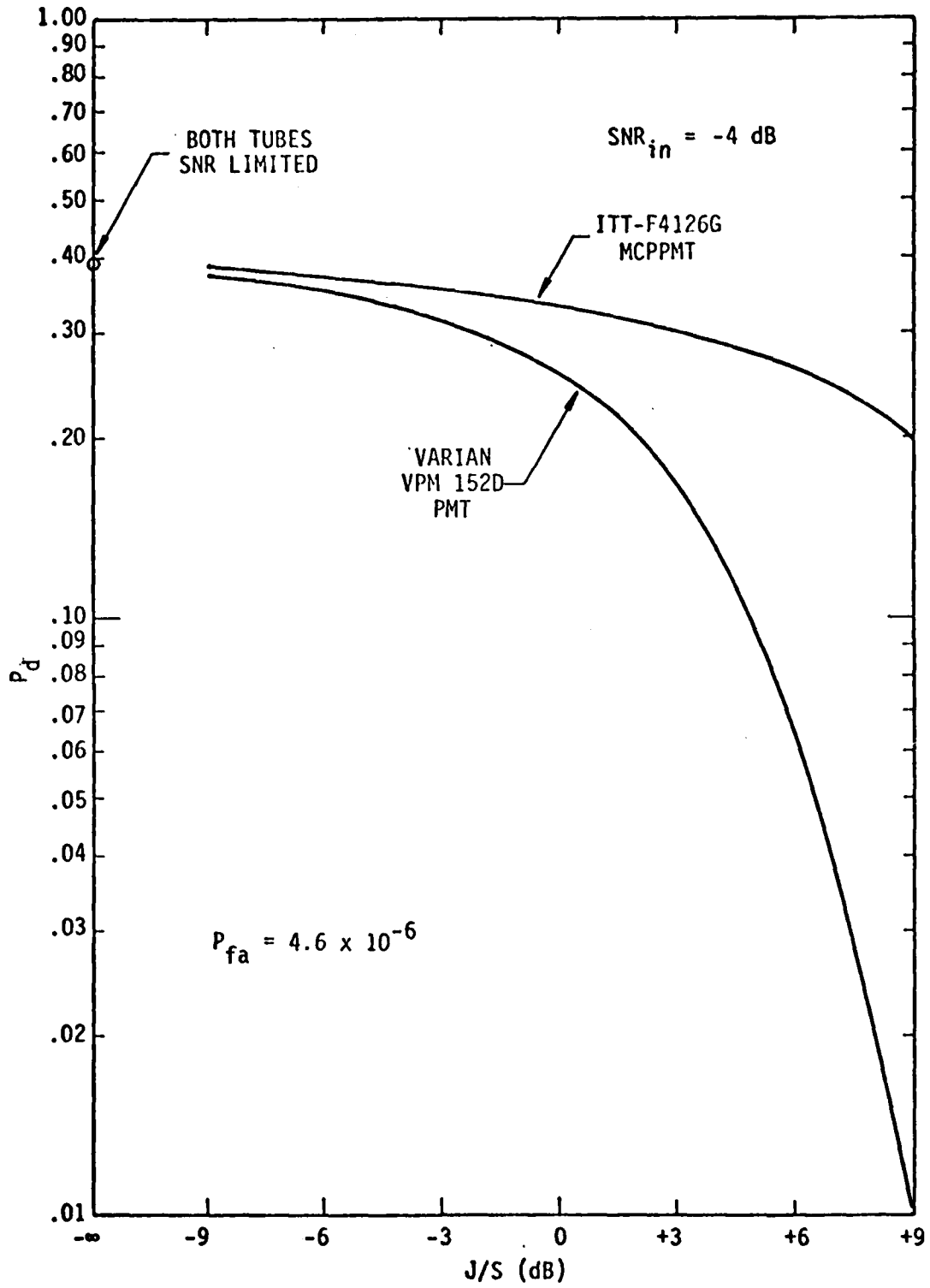

FIGURE 11
 PROBABILITY OF DETECTION AS A FUNCTION OF J/S ($SNR_{in} = -4$ dB)

3.3 --Continued

In Figures 12 and 13, excision of interference when no noise is added at the input is shown. These results are similar to the previous data. At a broadband J/S of +9 dB, Figure 12 indicates approximately an 18 dB reduction of the J/S in the analyzer 100 kHz IF bandwidth. In Table 2 and Figure 13 the results are similar to those shown in Table 1 and Figure 11. The MCPMT provides an enhanced P_d for any particular J/S, and for a 21% probability of detection we have approximately the same reduction in the apparent J/S present at the input to the digital matched filter.

TABLE 2
MATCHED FILTER SIGNAL DETECTIONS ($SNR_{in} = \infty$)

J/S (dB)	N_d (DETECTIONS/SEC)	
	VARIAN PMT	ITT MCPMT
$-\infty$	37,254	37,275
-9	35,040	35,620
-6	32,513	34,900
-3	28,436	33,474
0	20,829	32,071
+3	11,793	28,784
+6	4,249	23,830
+9	948	16,611

$$N_{fa} = 92$$

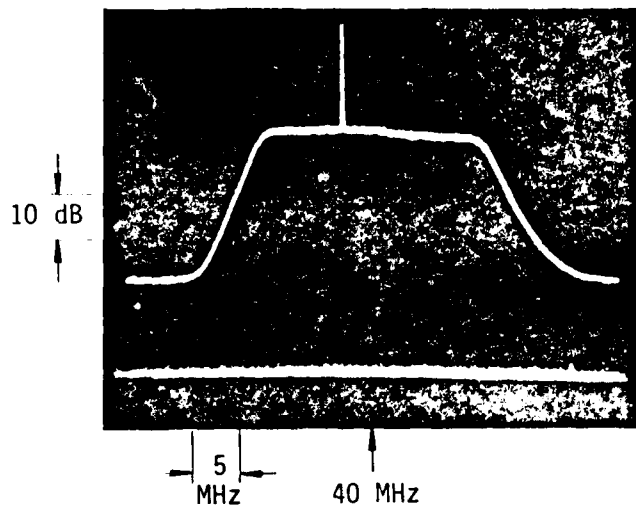

A. CONVENTIONAL PMT OUTPUT
 $J/S = +9$ dB

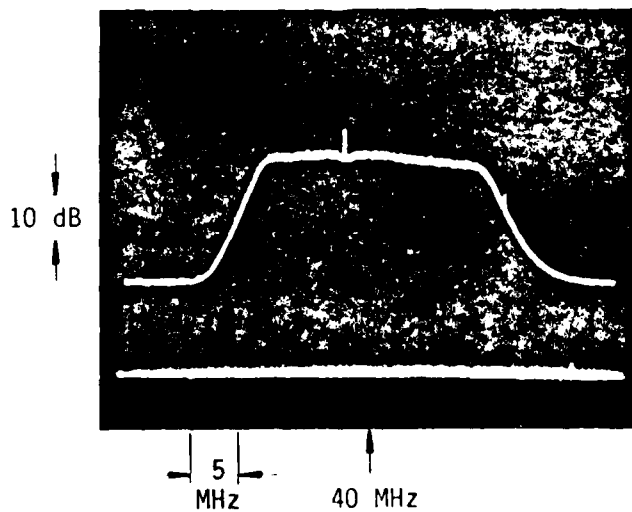

B. MCPPMT OUTPUT
 $J/S = +9$ dB

FIGURE 12 OUTPUT SPECTRUM WITH $SNR_{in} = \infty$

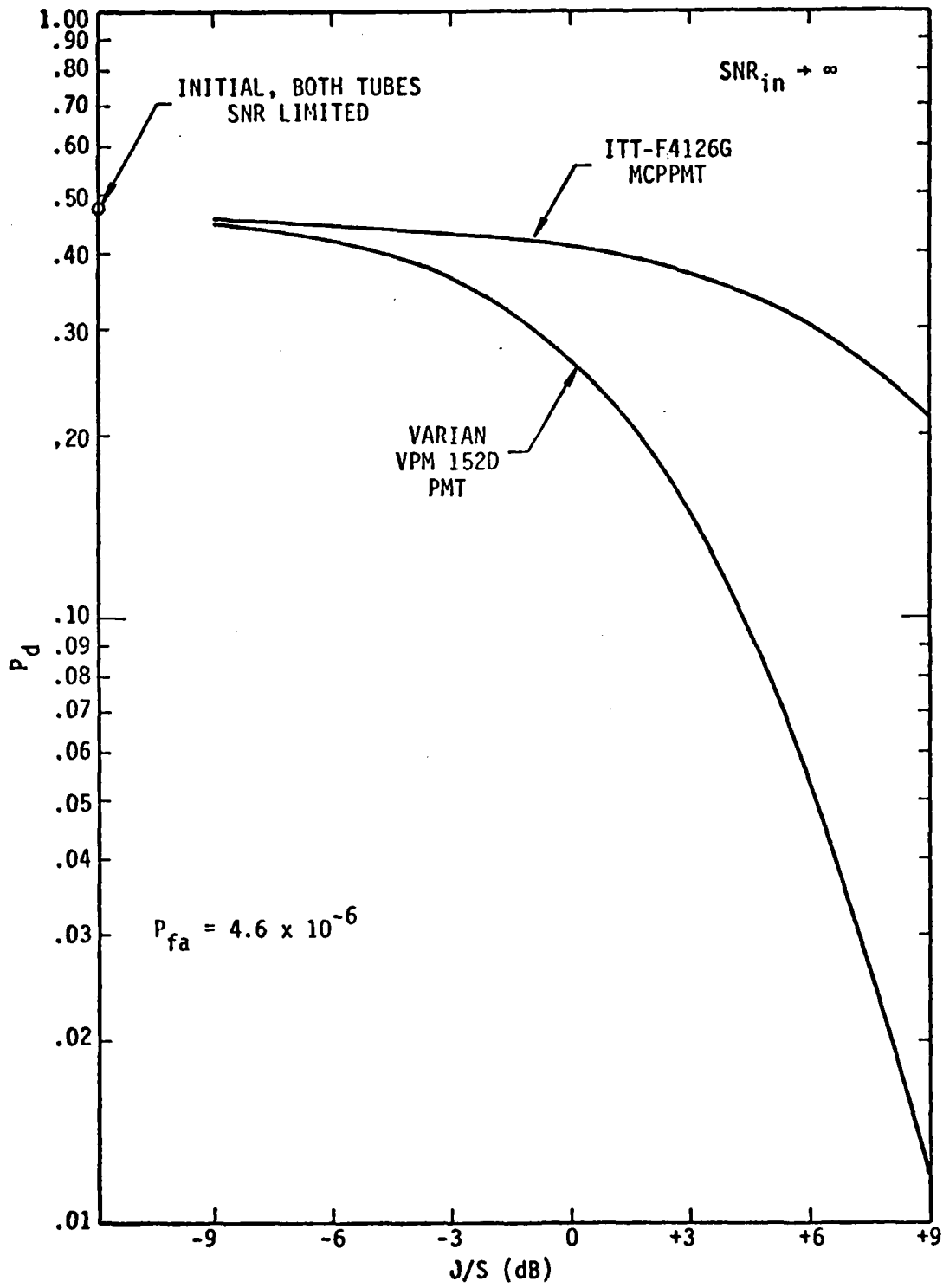

PSI-80058

FIGURE 13
 PROBABILITY OF DETECTION AS A FUNCTION OF J/S ($SNR_{tn} = \infty$)

SECTION 4 CONCLUSIONS

The work presented in this report meets the objective of demonstrating the feasibility of using a microchannel plate photomultiplier detector in an optical excisor. The secondary objective of this work is to provide a preliminary evaluation of a standard MCP-PMT detector and indicate the direction of future developments that would yield detectors suitable for use in a compact, rugged optical excisor.

It is concluded from the results presented here that localized saturation effects in a MCP-PMT can be used to reduce the gain of an optical excisor for narrowband interference signals while at the same time passing broadband signals. This frequency selective limiting of narrowband interference was shown to reduce interference down to the receiver noise level and improve the detection of spread spectrum signals by over an order of magnitude.

This technical approach holds considerable promise for the capability for an optical excisor that is self-adaptive, has instantaneous response to new interference signals, and would not require any more support hardware or volume than one using a conventional detector. With the feasibility having been demonstrated, the next step is to conduct the exploratory and engineering development necessary to better understand the system tradeoffs possible with this approach and to develop a microchannel plate photomultiplier tube that would have the long lifetime and saturation characteristics desired in a final device.

DC testing of the MCP-PMT initially resulted in concern regarding the saturation properties of the tube. Discussions with staff at ITT, Fort Wayne, provided possible explanations of tube behavior, but the data taken in the experiments provide no conclusive proof of the postulated causes. ITT indicated that as the secondary emission current approaches the strip current, the gain might not drop even though the potential gradient change should cause a drop because of space charge effects within the channel (i.e., electron energy does drop but

4. --Continued

the number of collisions with the secondary emitter increases due to the space charge within the channel). While this is a possible explanation for linearity as saturation is approached, it leaves open the question of secondary emission currents exceeding the strip current. In the case of a pulsed optical source illuminating the tube, the peak current can greatly exceed the strip current, as demonstrated by others, but it is suggested that this was due to the capacitive charge storage of the MCP. ITT postulates a possible reason for the results of the DC tests conducted by PROBE that indicated emission currents greater than the strip current. This effect, they think, is thermal in origin -- heating within the secondary emitter at high current densities resulting in increased strip current. Since strip current could not be monitored during DC testing, this possible cause cannot be validated. ITT also points out that since the electrons from saturated channels are presumably ejected from the MCP at lower energies than those from non-saturated channels, it should be possible to enhance the saturation effect by applying a retarding rather than an accelerating potential on the anode. The field so formed would tend to repel low energy electrons, yet those with energies above some threshold could still reach the anode.

In discussions with ITT, the possibility of unexpected dynamic behavior of the tube was mentioned. One staff member indicated that a pulsed optical beam illuminating the MCPPMT in conjunction with a CW optical beam generating an anode current near the strip current might result in oscillations at the anode. This would tend to indicate that the DC and AC saturation characteristics of the tube could differ. PROBE SYSTEMS' testing of the MCPPMT indicated that the tube does saturate with AC signals. The broadband AC tests provided more quantitative data indicating saturation as well as providing a measure of the MCPPMT's effectiveness in the suppression of narrowband RF interference in spread spectrum signals.

SECTION 5 RECOMMENDATIONS

Future developments in the electronic clipper for optical excision should be concentrated in two major areas. With reasonable investments in this work, it should be possible to provide a near-term capability to deploy broadband radar, communication, and intercept systems that are relatively immune to the disastrous effects of narrowband jamming and interference signals.

The two areas of development concentrate on the detector and on system level tests because technology support for other areas in optical excisor development have been and will receive support as parts of other programs. The following two sub-sections provide general descriptions of the work needed to realize a practical optical excisor.

5.1 SYSTEM-LEVEL DEVELOPMENTS

The microchannel plate photomultiplier electronic clipper holds considerable promise in being able to provide the capability to reduce interference signals down to the receiver noise level and respond so quickly to new signals that the detector will saturate before the signal would have appeared at the processor output port. The impact of these potential capabilities has yet to be investigated because before the invention of an electronic clipper optical excisor such capabilities were orders of magnitude beyond the capabilities of digital or analog circuits.

Both analytical and experimental investigations are needed in system-level developments. In the analytical area, PROBE SYSTEMS has already conducted several studies as to the need for and improvements possible with frequency selective limiters, but the limitations of conventional technology concentrated these studies into areas where the excisor had a relatively small number of frequency resolution cells. The optical excisor offers the possibility of having as much as 1000 frequency cells, which would be the optimum number for intercept receiver systems having up to 70 dB of processing gain.

5.1 --Continued

Analytical investigations of high resolution excisors would help determine tradeoffs between the number of frequency cells, the maximum excision depth of attenuation, the phase effects in the vicinity of excision notches, and the time delay of the output signal relative to the input signal. A unique area of analytical investigation will be the estimation of the output waveform during the leading edge of a new interference signal. This is unique because the micro-channel plate will begin to saturate as soon as an interference signal enters the Bragg cell. As the leading edge of the interference signal travels across the Bragg cell, the power spectrum of the interference will change from broadband to narrowband.

The detector output is the time waveform of the signal at a given time delay (or location in the Bragg cell), but it is now not known what the effects of the narrowband interference signal will be as the detector saturates on the changing power spectrum. A better understanding would permit the design of an optical excisor that would have minimal effects due to the leading edge of a new interferer and yet be able to saturate on the interference power spectrum before the signal was to be observed at the output. With this approach it should be possible to excise a new interferer before it had a chance to appear at the processor output and therefore be able to instantaneously respond to changes in the electronic signal environment.

The other major area of system-level development should be in experimental demonstrations and measurements where an optical excisor is part of a developmental or operational broadband system. When results are obtained with real hardware operating in real signal environments, potential users will more readily accept the value of optical excision. The potential capabilities of an optical excisor are such a quantum leap forward that system designers do not have hands-on experience or performance curves that can be extrapolated to predict the benefits that can be realized by using an optical excisor in present and future systems.

5.1 --Continued

PROBE SYSTEMS has, on numerous occasions, conducted field experiments in intercepting broadband signals and is in an excellent position to extend the interceptor's performance by including an optical excisor in future experiments. These field tests can include broadband radar and communication signals and could be the first step in designing experiments where the optical excisor is used in the front end of the receivers under test.

5.2 DETECTOR DEVELOPMENTS

To realize the full potential of an excisor using the microchannel plate technology, a custom tube is needed that has been optimized for the excisor application. Many of the design options taken by developers of today's off-the-shelf microchannel plate photomultipliers were based on pulsed applications and were not necessarily optimum for hetrodyne detection of images.

In the excisor application, four areas need to be addressed in the specification and development of a custom MCP/PMT. These Are:

- Enhancement of MCP saturation properties
- Greater linear dynamic range
- Better photocathode/MCP form factor
- Higher resistance to damage

Preliminary discussions with a potential vendor, ITT, have addressed saturation, damage resistance, and briefly, dynamic range. ITT also has a demonstrated capability building MCP's of various sizes and shapes. Discussions with Varian, the other potential vendor, has been limited to saturation and damage resistance (inherent in Varian's MCP/PMT design). Another area discussed with Varian has been photocathode sensitivity in the near IR, a desired feature since a compact excisor will eventually use a diode laser.

APPENDIX
SPREAD SPECTRUM TEST SIGNAL GENERATOR
AND DIGITAL MATCHED FILTER

The broadband AC tests described in this report employed a spread spectrum test signal generator and digital matched filter developed by PROBE SYSTEMS in 1977. This appendix provides a brief introduction to these equipments and their operation.

A.1 TEST SIGNAL GENERATOR

Generation of a PN biphas spread spectrum signal may be accomplished by employing a pseudo-random bit stream (the spreading code) to control the phase of a carrier signal. This type of spreading allows two possible phase states in the output signal with respect to the carrier: 0 and 180° . The waveform so generated will exhibit spectral characteristics (center frequency, bandwidth, fine spectral structure, etc.) that are a function of the carrier and the characteristics of the spreading code (clock rate, code length, the specific code, etc.).

The test signal generator consists of a carrier frequency generator, a double-balanced mixer, the pseudo-random sequence generator, and a sequence generator clock.

Phase reversal of the carrier is accomplished by the mixer. One port, the LO, is driven by the carriage generator. When step signal changes occur at the IF port the phase of the carrier signal at the RF port of the mixer reverses.

In the test signal generator the mixer IF port is driven by the pseudo-random sequence generator. This generator consists of a 7-bit shift register connected to produce a periodic pseudo-random sequence having a length of 127 sequence clock cycles. By feeding various shift register bits back to the register input through an exclusive-OR gate, the sequence is generated.

A.1 --Continued

The spread spectrum signal generated by the test signal generator used in testing the MCPPMT had the following characteristics:

Carrier Frequency:	40 MHz
Mainlobe Bandwidth (Null to Null):	20 MHz
Chip Rate:	10 MHz
Code Length:	127 Bits
Code Repetition Rate:	78.125 kHz

These signal characteristics were selected to match Bragg cell center frequency and bandwidth specifications.

A.2 MATCHED FILTER

Detection of a PN biphase spread spectrum signal may be accomplished with a filter matched to the spreading code. The output of such a filter will exhibit a waveform corresponding to the cross-correlation of the input signal with the spreading code and therefore will exhibit a peak at the time of code/signal alignment. The presence of this peak demonstrates the presence of the spread spectrum signal and, hence, can be used for signal detection.

PROBE's implementation of this filter consists of a 1-bit analog-to-digital converter providing a binary representation of the input signal to a shift register delay line of 512 bits. Every fourth tap of this register is exclusive-OR'd with the taps of a 128-bit static register containing the pseudo-random binary sequence being correlated. The outputs of the exclusive-OR gates are all summed together in a resistive analog summer which provides the correlation function between the input signal and the spreading code.

Having a delay line length of 512 bits, which is four times the code sequence length, provides a sampling rate of the input waveform at four times the chip rate (code bit rate). This allows cross-correlation to be performed on RF,

A.2 --Continued

IF, or baseband signals without the use of in-phase and quadrature demodulators. The upper sampling rate of the input waveform is governed by the maximum clock rate for the delay line registers, which is 200 MHz. This rate allows PROBE's digital matched filter to perform cross-correlation on spread spectrum signals having chip rates as high as 50 MHz and bandwidths as high as 100 MHz.

Since the length of the pseudo-random sequence is 127 bits, it has a theoretical maximum processing gain of 21 dB. Because the amplitude resolution is limited to 1 bit, a 2-dB loss is incurred, yielding a theoretical 19-dB gain.

A.3 OPERATION

In the laboratory, the processing gain was determined in three different configurations. The test signal generator was connected back-to-back with the matched filter in the first test. In the second test, it was connected to the excisor electronics signal input port. The Bragg cell drive was attenuated and tied directly to the PMT input connector on the excisor electronics. Then the excisor electronics' output signal drove the matched filter. The third test was the same as the second except that the optical processor was placed in the loop. The Varian PMT was used rather than the MCPPMT, and in this configuration the optical processor approximates an electrical short circuit. In all three tests the gain of the digital matched filter was 17 dB, only 2 dB from the theoretical value.

Processing gain and SNR can be determined with the test signal generator/matched filter by measurement of the number of detections, N_d , per second and the number of false alarms, N_{fa} , per second. To measure N_d and N_{fa} , the output of the matched filter is applied to a crystal video detector followed by thresholding circuitry which provides output pulses for each correlation peak above a threshold voltage (see Figure 7, Electronic Setup for Broadband Test). For excisor testing, thresholding was accomplished using a lab oscilloscope's variable trigger circuitry. Input pulses from the detector which triggered

A.3 --Continued

the scope resulted in pulses at the A-gate output which were counted on a frequency counter. When no correlated signal was present at the input to the matched filter, detector outputs exceeding the selected threshold are defined as false alarms. With a spread signal at the input, then output pulses are considered to be detections (as long as $N_d \gg N_{fa}$).

The probability of detection, P_d , at some threshold level is then just N_d divided by N_d^- , the number of detections per second possible (code repetition rate). The probability of false alarm, P_{fa} , can be calculated by dividing N_{fa} by the detection bandwidth. From P_d and P_{fa} , the post-detection SNR can then be found in the graphical data presented by Skolnik in "Radar Handbook," as well as from other sources.

To find the processing gain of the digital matched filter, the SNR is set at the input to the filter and the gain is then simply the post-detection SNR minus the input SNR. Once this value is found it is possible to determine the SNR at the input to the matched filter even though the spread spectrum signal level is well below the noise level.