



LEVEL II

ADA 086966

**DEPARTMENT OF DEFENCE
DEFENCE SCIENCE AND TECHNOLOGY ORGANISATION
AERONAUTICAL RESEARCH LABORATORIES
MELBOURNE, VICTORIA**

AERODYNAMICS REPORT 152

**SEA KING MK. 50 HELICOPTER
SONAR DYNAMICS STUDY
A SIMPLIFIED CONTROL SYSTEMS
MATHEMATICAL MODEL**

THE UNITED STATES NATIONAL
TECHNICAL INFORMATION SERVICE
IS AUTHORIZED TO
REPRODUCE AND SELL THIS REPORT
by

C. R. GUY

Approved for Public Release.



**DTIC
SELECTED
JUL 23 1980
S D D**

© COMMONWEALTH OF AUSTRALIA 1979

FEBRUARY 1979

COPY No 10

DDC FILE_COPY

80

7 99 000

Accession For	
NIIS GRA&I	<input checked="" type="checkbox"/>
DDC TAR	<input type="checkbox"/>
Unannounced	<input type="checkbox"/>
Justification	
By _____	
Distribution/ _____	
Availability Codes	
Dist	Availand/or special
A	

AR-001-607

DEPARTMENT OF DEFENCE
DEFENCE SCIENCE AND TECHNOLOGY ORGANISATION
AERONAUTICAL RESEARCH LABORATORIES

AERODYNAMICS REPORT 152

**SEA KING MK. 50 HELICOPTER
SONAR DYNAMICS STUDY
A SIMPLIFIED CONTROL SYSTEMS
MATHEMATICAL MODEL**

by

C. R. GUY

SUMMARY

A mathematical model, formulating a simplified version of the control systems used in the Sea King Mk. 50 helicopter, is described. The model represents the overall control laws and systems used in the aircraft, although it does not represent each individual element of the control systems. The control systems model, together with models of the aerodynamics/kinematics and sonar cable/transducer, form the complete model for the Sea King Mk. 50 helicopter/sonar dynamics study. Sample results showing the flight behaviour of the complete model are included.

**DTIC
ELECTE
S JUL 23 1980 D
D**

DOCUMENT CONTROL DATA SHEET

Security classification of this page: Unclassified

- | | |
|--|--|
| <p>1. Document Numbers</p> <p>(a) AR Number:
AR-001-607</p> <p>(b) Document Series and Number:
Aerodynamics Report 152 ✓</p> <p>(c) Report Number:
ARL-Aero-Report 152</p> | <p>2. Security Classification</p> <p>(a) Complete document:
Unclassified</p> <p>(b) Title in isolation:
Unclassified</p> <p>(c) Summary in isolation:
Unclassified</p> |
|--|--|

3. Title: SEA KING MK. 50 HELICOPTER/SONAR DYNAMICS STUDY;
A SIMPLIFIED CONTROL SYSTEMS MATHEMATICAL MODEL

- | | |
|---|---|
| <p>4. Personal Author(s):
Guy, Christopher R.</p> | <p>5. Document Date:
February, 1979</p> |
|---|---|

6. Type of Report and Period Covered:

- | | |
|---|---|
| <p>7. Corporate Author(s):
Aeronautical Research Laboratories</p> | <p>8. Reference Numbers</p> <p>(a) Task:
RD 69/74/4</p> <p>(b) Sponsoring Agency:</p> |
|---|---|

- | | |
|----------------------------------|---|
| <p>9. Cost Code:
51 2090</p> | <p>11. Computer Program(s)
(Title(s) and language(s)):
SKING (CSMP-10 (ARL) and Fortran IV)</p> |
|----------------------------------|---|

- | | |
|--|---|
| <p>10. Imprint (Publishing establishment):
Aeronautical Research Laboratories, ✓
Melbourne</p> | <p>11. Computer Program(s)
(Title(s) and language(s)):
SKING (CSMP-10 (ARL) and Fortran IV)</p> |
|--|---|

12. Release Limitations (of the document)
Approved for Public Release

12-0. Overseas:	N.O.		P.R.	I	A		B		C		D		E	
-----------------	------	--	------	---	---	--	---	--	---	--	---	--	---	--

13. Announcement Limitations (of the information on this page):
No Limitation

- | | | |
|---|--|--|
| <p>14. Descriptors:</p> <p>Helicopters</p> <p>Flight control</p> <p>Control equipment</p> | <p>Mathematical models</p> <p>Sea King (Helicopters)</p> | <p>15. Cosati Codes:</p> <p>1201</p> <p>0103</p> |
|---|--|--|

16. **ABSTRACT**

A mathematical model, formulating a simplified version of the control systems used in the Sea King Mk. 50 helicopter, is described. The model represents the overall control laws and systems used in the aircraft, although it does not represent each individual element of the control systems. The control systems model, together with models of the aerodynamics/kinematics and sonar cable/transducer, form the complete model for the Sea King Mk. 50 helicopter/sonar dynamics study. Sample results showing the flight behaviour of the complete model are included.

CONTENTS

	Page No.
1. INTRODUCTION	1
2. FLYING CONTROLS	2
2.1 Pitch Channel	2
2.2 Roll Channel	2
2.3 Yaw Channel	2
2.4 Collective Channel	3
3. AUTOMATIC FLIGHT CONTROL SYSTEM	3
3.1 General	3
3.2 Autostabilizer/Autopilot Mode	3
3.2.1 Pitch Channel	3
3.2.2 Roll Channel	3
3.2.3 Yaw Stabilizer and Heading Hold	4
3.2.4 Barometric Height Hold	4
3.3 ASW Mode	4
3.3.1 Pitch Channel	5
3.3.2 Roll Channel	5
3.3.3 Radio Altitude Hold	6
3.3.4 Beeper Trim System	6
4. SAMPLE RESULTS	6
5. CONCLUDING REMARKS	7
NOMENCLATURE	
REFERENCES	
APPENDIX I: EQUATIONS OF THE SIMPLIFIED CONTROL SYSTEMS MATHEMATICAL MODEL	
FIGURES	
DISTRIBUTION	

1. INTRODUCTION

The object of this report is to describe a mathematical model of a simplified version of the flying controls and automatic flight control system (AFCS) used in the Sea King Mk. 50 helicopter. This model is used in conjunction with models representing the aerodynamics/kinematics and sonar cable/transducer for the helicopter. The complete model constitutes part of a study of the flight behaviour of the Sea King helicopter operated by the Royal Australian Navy. The study presented here is similar to a Wessex helicopter/sonar dynamics study previously undertaken by Packer at Weapons Research Establishment† (Refs 1-4). An overall block diagram for the Sea King helicopter/sonar system model is shown in Figure 1.

The version of the control systems model described here represents the overall control laws and systems used in the aircraft, although it does not represent each individual element of the flying controls and AFCS. The reasons for constructing a simplified model are:

- (i) If all elements are included, the system becomes very complex; this degree of complexity is considered unnecessary for many tasks required of the model.
- (ii) The model can be easily linearized for systems analysis work.

However, a model which does include all elements of the control systems is being constructed for tasks where the simplified model is inadequate (for example, the investigation of defects in particular components).

The basis for the simplified model is to keep the control systems as simple as possible while yet enabling the aircraft to perform most manoeuvres required of it. When performing these, the control system is designed to operate in a similar fashion to that in the aircraft. Consequently some characteristics, such as the input/output relationships of the primary servos, can be represented as constant gearings, with time constants and non-linearities neglected, because they have little effect on the behaviour of the entire aircraft system in the majority of operating conditions. Other facilities however, such as the AFCS authority limits, the automatic cyclic stick (beeper) trim system and the auxiliary servo open-loop spring operation, all of which have a significant influence on aircraft behaviour, are included.

Section 2 of this document describes the flying controls of the aircraft, while Section 3 describes the AFCS and outlines some manoeuvres which the aircraft can perform automatically. The AFCS can be subdivided into an autostabilizer/autopilot mode and an anti-submarine warfare (ASW) mode. References 5-8 describe the parts of the aircraft control systems which are relevant to this document and Reference 9 covers general aspects of helicopter flight control systems. Sample results showing the flight behaviour of the model are presented in Section 4.

Block diagrams for the model are presented in Figures 3-15 and its equations are listed in Appendix I. The block diagrams are constructed from diagrams of the physical system contained in References 5-8 and from circuit diagrams and data for the AFCS supplied by Louis Newmark Ltd, manufacturers of the equipment. They form a link between the physical system and the mathematical model, with much of the text of this report referring to them. The equations representing the control systems can be deduced from the block diagrams. Additional information on the control laws was supplied by Westland Helicopters Ltd, and some parts of the model (for example, the beeper trim system) were based on Packer's Wessex model. In addition, the models of the aerodynamics/kinematics and sonar cable/transducer which combine with the control systems model are directly established from Packer's work (Refs 1-4). The completely computer based model allows greater flexibility for investigating problems than a hybrid model of computer simulation plus aircraft hardware. It also includes the relatively unusual feature of cable and sonar dynamics which enable anti-submarine warfare cable hover investigations to be made.

† Now Defence Research Centre, Salisbury.

2. FLYING CONTROLS

This section provides descriptions of each channel of the flying controls used in the model. Equations (1.1) to (1.28) presented in Appendix 1 are relevant to the section. The aircraft's flying controls are shown in Figure 2 and described in detail in Reference 5.

The aircraft is controlled by changes in pitch of the main and tail rotor blades which are actuated either by pilot inputs or AFCS inputs through the flying controls. The pilot's main controls are conventional; i.e. a cyclic stick which moves both longitudinally and laterally, the collective pitch lever and rudder pedals. The cyclic controls produce longitudinal and lateral horizontal movements in flight through blade angle variations which tilt the rotor tip path plane and hence the thrust vector to give a component in the desired direction. The collective pitch lever controls the ascent and descent of the aircraft by identical variation in the pitch of each of the main rotor blades. The rudder pedals change the collective pitch of the tail rotor blades thereby varying thrust to obtain directional (yaw) control. In the aircraft, AFCS signals are input to the flying controls through the auxiliary servo unit. This comprises four jacks, one for each channel.

2.1 Pitch Channel (Fig. 3)

The pitch channel has been represented by:

- (i) A cyclic stick model, which uses an integrator. This enables cyclic stick angle (THE STK)[†] to be controlled by THE PIL, the pilot's selected stick angle, or by the beeper trim system through the integration of THE TDT (the rate of change of stick angle, an output of the beeper trim system—see Section 3.3.4), depending on the sense of the trim release switch, S TRM RL. When S TRM RL is on, the integrator is in the reset mode; when S TRM RL is off, it is in the run mode. Note that the stops \pm EL CP limit the range of THE STK.
- (ii) A model relating THE STK and the AFCS autostabilizer/autopilot output signal (AUTO PL) to cyclic blade pitch angle (BIS). The constant CPI represents the gearing of the mechanical/hydraulic components between THE STK and BIS.

2.2 Roll Channel (Fig. 4)

Similar to pitch channel.

2.3 Yaw Channel (Fig. 5)

Unlike the auxiliary servos in the pitch and roll channels, that in the yaw channel incorporates an open-loop spring which extends the authority of the AFCS and allows the pilot to override the AFCS if necessary. This influences the operation of the flying controls and hence some servo characteristics must be modelled.

Referring to Figure 5, an integrator is used to model the pedal displacement (D PEDLS). S PEDLS represents the yaw force link switch which enables overriding of the AFCS to occur. The auxiliary servo has been mathematically modelled as a first order lag circuit with an extra input for AFCS signals (AUTO YL) and an open-loop spring linkage position (D SPR Y). This integrator/feedback model results in the type of characteristic which approximates the response of the servo.

The rate of change of rudder pedals position (D PED DT) is generated from D SPR Y. When a large AFCS demand signal (AUTO YL) is applied to the auxiliary servo, D SPR Y may exceed the open-loop spring compression limit, EL OY. This gives rise to a non-zero value of D PED DT which causes movement of the pedals. The value of gearing CY11 represents the pedal damper characteristics.

THETA T, the tail rotor collective blade pitch angle, comprises the sum of:

- (i) The geared auxiliary servo output position.
- (ii) Constant CY2, which represents the mid-point of the range of THETA T.
- (iii) The geared yaw crossfeed term.

[†] Throughout this document, the format for variables is of the type used here. This enables a computer program of the mathematical model to be written without changing variable names.

2.4 Collective Channel (Fig. 6)

This is generally similar to the yaw channel except there is no cross-feed term and stick position is referenced relative to the aircraft's horizontal datum rather than mid-stick position.

3. AUTOMATIC FLIGHT CONTROL SYSTEM (AFCS)

This section provides a general description of the AFCS (paragraph 3.1), followed by detailed descriptions of each of its two operating modes. The autostabilizer/autopilot mode, which is subdivided into pitch channel, roll channel, yaw stabilizer/heading hold and barometric height hold, is described in paragraph 3.2, while paragraph 3.3 contains an outline of the anti-submarine warfare (ASW) mode. This mode is subdivided into pitch channel, roll channel, radio altitude hold and beeper trim system sections. Where appropriate, an explanation of the control law philosophy is given. A description of the aircraft's AFCS is given in References 6, 7 and 8.

3.1 General

The AFCS is installed to ease the pilot's task in operating the aircraft through all phases of flight and, in particular, to improve the operational effectiveness of the aircraft in the anti-submarine warfare role. Without an AFCS some tasks would be virtually impossible. The main features of the system are:

- (i) Three-axis stabilization (pitch, roll and yaw channels).
- (ii) Attitude, heading and height hold in cruising flight.
- (iii) Controlled transition manoeuvres to and from the hover.
- (iv) Automatic height and plan-position control in the hover.

The authority of the AFCS is limited to either 5% or 10% of the total blade travel, depending on the channel. This authority limitation enables the pilot to have control of the aircraft in the event of a hardover failure of the AFCS. Extended control authority is provided by the open-loop spring mechanisms in the yaw and collective channels (see Section 2) and by the beeper trim system in the cyclic channels (see Section 3.3.4).

3.2 Autostabilizer/Autopilot Mode

When the autostabilizer facility is engaged, the system functions as an attitude-holding stabilizer. The system stabilizes the aircraft at the pitch and roll attitudes and heading established through the normal flying controls. Artificial damping is applied to motion of the aircraft in pitch, roll and yaw. Autopilot facilities are heading hold and barometric altitude hold.

3.2.1 Pitch Channel (Fig. 7)

Engagement of the pitch channel autostabilizer/autopilot mode signal (AUTO PL) is made through switch S AUTO P. The attitude holding and stabilizing characteristics of the system are achieved by use of the geared pitch attitude angle signal (from a vertical gyro in the aircraft) and its geared approximate derivative (from an electronic network in the aircraft) in the control law (see Appendix I, equation 2.1). The stick canceller signal partially cancels the attitude signal so as to allow a wider range of attitude control without exceeding the authority limit EL AP and also improves the response of the aircraft to pilot demands (Ref. 9). ASW mode signals are incorporated through the term ASW P and pitch trim is included through the term THE TRM. When changes of aircraft centre of gravity occur, it becomes necessary to use THE TRM to bias the control-position signal.

3.2.2 Roll Channel (Fig. 8)

This is similar to the pitch channel, except that:

- (i) A lag network, which operates on the combined stick canceller and trim signals is used.
- (ii) The signs associated with the attitude term and its derivative are different from those of the pitch channel. This arises from the sign convention adopted for each variable in the entire aircraft/control systems/cable model.

3.2.3 Yaw Stabilizer and Heading Hold (Fig. 9)

Engagement of signal AUTO YL is made through switch S AUTO Y. When this is on and the yaw force link switch (S PEDLS) is off, heading hold and yaw rate damping are provided. When both S AUTO Y and S PEDLS are on, the channel functions as a yaw damper only.

Yaw damping is provided by rate feedback; i.e. the geared R HEH term in the control law (Appendix I, equation 2.9). The heading hold control law uses the error signal PSI ERR (the difference between the trimmed and reference headings) and the integral of error signal PSI INT, which is included to improve steady-state performance.

If PSI INT is non-zero when S PEDLS is engaged, it is 'washed out' by means of the feedback loop around the integrator, thus enabling PSI INT to be zero prior to the aircraft adopting a new heading when S PEDLS is disengaged. Note, however, that changes in heading can be made without using the pedals by means of the heading trim control PSI TRM.

3.2.4 Barometric Height Hold (Fig. 10)

Engagement of the barometric height hold signal (AUTO CL) is made through the mode switch S AUTO C and the barometric height hold switch S BAR A. At the moment when S BAR A is engaged, the height datum (H REF) is set and subsequent deviations in height are fed through the collective channel to stabilize the aircraft at H REF. When a change in height is made (a barometric altitude manoeuvre), S BAR A must be switched off. Immediately S BAR A is re-engaged, altitude hold is re-established relative to the new value of barometric altitude to which the aircraft has been flown.

These facilities are achieved as follows. The H REF signal is obtained from the barometric height signal (Z HEE) using a sample and hold device which is switched by S BAR A. Note that the sign conventions for Z HEE and H REF are opposite. The altitude error signal, BAR A, is the difference between Z HEE and H REF after gearing and modification by the smoothing (gust filter) circuit. Also, if S BAR A (or S RAD A) is on, CLU A is proportional to the difference between the prevailing collective stick angle (THEC ST) and the clutched collective stick angle (THE CLU) existing at the time when S BAR A (or S RAD A) was engaged. The clutch action enables the barometric altitude manoeuvres described above to be performed.

If open-loop spring operation of the collective stick takes place because of large AFCS signals in the auxiliary servo unit, the clutched pick-off signal varies in opposition to the barometric height error signal. In this case the feedback arrangement operates to move THEC ST approximately in proportion to the amplitude of BAR A. This improves the stability of the altitude hold when large barometric height error signals occur.

3.3 ASW Mode

ASW mode facilities provided by the AFCS and incorporated in the model are:

- (i) Radio altitude hold.
- (ii) Transition down.
- (iii) Doppler hover.
- (iv) Cable hover.
- (v) Transition up.

With radio altitude hold engaged, the collective channel provides stabilization at the selected height. The facility also provides accurate control of height during transition down, doppler hover, cable hover and transition up manoeuvres.

Transition down is the automatic manoeuvre which brings the aircraft to the hover in readiness for the 'dunk' phase of ASW operations. When transition down is commenced, the aircraft begins an automatically controlled descent to hovering altitude, at the same time decelerating to zero groundspeed. Sideways drift is controlled by doppler radar during the manoeuvre.

At the completion of transition down, the doppler hover commences; the aircraft hovers at zero groundspeed and at the selected altitude while the sonar submersible unit (S.U.) is lowered. When this enters the water, cable hover is initiated so that the plan-position of the aircraft is automatically controlled to keep the S.U. as upright and still as possible in the water. This is the best operating condition of the S.U. for performing a sonar search.

After finishing the search, the doppler mode is re-selected. The S.U. is winched from the water and when ready to break hover, the transition up manoeuvre commences. This causes the aircraft to climb out from the hover to the desired altitude and groundspeed.

3.3.1 Pitch Channel (Fig. 11)

This channel governs control of transition, doppler hover and cable hover manoeuvres in the fore-aft direction. The action of the control causes cyclic changes of blade pitch which result in airspeed variations and hence groundspeed changes. Two control laws are used, one for transition and doppler hover manoeuvres (doppler mode control) and the other for cable hover manoeuvres (cable mode control). For the former, switch S DOP must be engaged (Fig. 11), with switch S CAB disengaged and for the latter, S CAB must be on with S DOP off.

To achieve doppler mode control, an essentially proportional plus integral law is used. The doppler longitudinal groundspeed error signal (DOP P) comprises:

- (i) The longitudinal groundspeed error signal; i.e. the difference between the aircraft's smoothed longitudinal groundspeed, V GVP and the reference longitudinal groundspeed, U COMM. U COMM determines the groundspeed profile for transition manoeuvres and is programmed to vary linearly from the entry speed to zero, or from zero to the exit speed, over a time period of 78s.
- (ii) Signal CADO IP, which is the integral of the modified groundspeed error signal U ERR. U ERR is the difference between U HEH and U COMM, when U COMM has been fed through an 'aircraft model' lag circuit. The output from the lag circuit represents 'predicted' groundspeed according to the known speed characteristics of the aircraft. In this way, the error signal fed to the integrator remains small; the integrator provides correction for long-term errors relative to the predicted groundspeed. Note that when S DOP is disengaged, provided S CAB remains off, signal CADO IP is 'washed out' to zero.

When S CAB is engaged, the cable hover mode commences. In order to maintain the S.U. still and upright in the sea, the aircraft is controlled to keep the cable angle at the sea surface vertical with respect to the earth. In still air this corresponds to the cable angle at the aircraft being vertical with respect to the earth, but in windy conditions the aircraft has to maintain a position ahead of the S.U. to counteract the bowing effect of wind on the exposed portion of the cable. The amount of forward displacement depends on wind strength and length of cable exposed. A pitch trim control is provided to enable windforce corrections to be made by offsetting the reference angle for control of the cable at the aircraft. This is provided in the longitudinal plane only, since the aircraft is headed into wind for sonar dunking operations.

To achieve this control, the cable mode signal (CAB P) comprises:

- (i) The proportional, trimmed, longitudinal cable angle error signal, THE ERT. THE ERT itself comprises:
 - (a) The pitch attitude angle of the cable relative to the earth. This is the difference between the pitch attitude angle of the helicopter relative to the earth (THE HE) and the pitch angle of the cable relative to the helicopters' z-axis (THE CH).
 - (b) The pitch trim angle of the helicopter relative to the earth (PIT TRM), which is used for windforce corrections.
- (ii) The longitudinal acceleration of the helicopter after smoothing. This provides a damping term which improves stability.
- (iii) The integral signal CADO IP, which helps to correct long-term errors. Note that when a switch from S DOP to S CAB is made, CADO IP remains constant. This enables continuity to remain in the integral error term when doppler/cable/doppler switching is made. In addition, CADO IP is 'washed out' when S CAB is switched off, provided S DOP remains off.

It should be noted that gearings MFP1 and MFP2, which attenuate signal THE ERT, are variable. The amount of attenuation is inversely proportional to the paid-out cable length (see equations 3.4).

3.3.2 Roll Channel (Fig. 12)

This is similar to the pitch channel except that the reference lateral groundspeed is zero throughout transition down, transition up and doppler hover manoeuvres. The system controls lateral cyclic pitch to maintain zero lateral groundspeed.

3.3.3 Radio Altitude Hold (Fig. 13)

For level flight with the radio altitude mode operative, H COMM is the set radio height and the control law operates to maintain the aircraft's height (Z HEE) at H COMM (note that the sign conventions for Z HEE and H COMM are opposite). The system enables the set radio height to be altered, thus making a controlled change in altitude without disengaging the radio altitude hold. When large changes of height are demanded, open-loop operation of the auxiliary servo unit has the effect of trimming the collective lever (see Section 2).

When a transition down manoeuvre commences, H COMM decreases linearly from the aircraft's altitude to the set hover height over a time period of 62s. It is held at this value during doppler hover and cable hover operations. For the transition up manoeuvre, H COMM ramps up linearly from the set hover height to the set radio height again over a period of 62s. The ramp starts 16s. after the transition up manoeuvre begins.

An essentially proportional plus integral plus velocity damping control law is used. The radio altitude hold signal, RAD A, comprises:

- (i) An altitude error term (proportional to the difference between Z HEE and H COMM).
- (ii) A damping term proportional to vertical velocity, W HEE, which improves stability.
- (iii) A signal proportional to the integral of the difference between Z HEE and H COMM, when the H COMM signal is modified by an 'aircraft model' lag circuit (see also Section 3.3.1). Note that when switch S RAD A is disengaged, signal Z ERI is 'washed out' through the integrator feedback loop.

3.3.4 Beeper Trim System

The beeper trim system provides for cyclic stick positioning, where control is accomplished automatically under signals from the AFCS, or by manual control switches (see also Section 2). The system enables extension of authority for the ASW pitch demand signal by actuating the control stick directly at a fixed rate of movement and in the aircraft works through electro-hydraulic valves in the auxiliary servo unit.

3.3.4.1 Pitch Channel (Fig. 14)

For beeper trim system operation to occur, the ASW mode output signal (ASW P) needs to exceed the beeping limit EL BP. When this happens, switch S POS P (or S NEG P, depending on direction) is actuated. To obtain correct timing for beeping signals, a multivibrator signal (S MULT P), of defined mark/space ratio, is used. When S MULT P and S POS P (or S NEG P) are both on, the beeping switch S FWD H (or S AFT H) is energized. As beeping can occur only in the ASW mode, switches S FWD NU and S AFT NU have the senses of S FWD H and S AFT H respectively only when either S DOP or S CAB is engaged. In this case, THE TDT, the rate of change of stick angle, takes either the value of constant CP11 or that of CP12. If the ASW mode is not operative, stick beeping can occur through actuation of S FWD NU and S AFT NU by the pilot's beeper trim switches S FWD and S AFT.

3.3.4.2 Roll Channel (Fig. 15)

Similar to pitch channel.

4. SAMPLE RESULTS

To demonstrate the performance of the aircraft/control systems, cable model, sample results from two tests are presented. In the first test, the model was programmed to perform the following manoeuvre:

- (i) Initial conditions: near-steady flight at a forward velocity of 153 ft/s† (90 kt or 46.6 m/s), altitude 200 ft (61 m), with autostabilizer, heading hold and radio altitude hold engaged.
- (ii) Transition down to hover at 40 ft (12.2 m) altitude, begun at 5s.
- (iii) Dunking of sonar transducer, begun at 100s.
- (iv) Run terminated at 200s.

† Because the computer programs for the models use imperial units, they are retained here.

Such a manoeuvre illustrates the performance of all parts of the models' control system except the barometric altitude hold facility. The time histories for some important variables are shown in Figure 16 and the main features are summarized below:

- (i) Overall, the aircraft performs the level flight, transition down, doppler and cable hover manoeuvres smoothly and in a reasonable manner in accordance with specifications.
- (ii) Initial deviations from the desired path are due to imperfect initial conditions.
- (iii) Note that automatic stick and pedal positioning (beeping) occurs during this run.
- (iv) The cable angles relative to the earth (THE CEL and PHI CEL) take a considerable time to settle to their desired values (zero rad).
- (v) Note that aircraft altitude (Z HEE) is measured positive downwards in the results presented. This follows from the (standard) conventions used for body axes in the aircraft.
- (vi) Because the model has not yet been validated, the behaviour shown still has to be confirmed as an accurate representation of full scale aircraft behaviour.

The second test was designed to show the performance of the barometric height hold facility. To do this, a steady, level flight manoeuvre, at a speed of 90 kt (46.6 m/s) was performed with the barometric height hold engaged. The aircraft was subjected to a downwards wind gust rising from zero to 5 ft/s (1.5 m/s) in 1s, beginning at 20s, duration 5s. Time histories for some relevant variables are shown in Figure 17 and the main features are:

- (i) Barometric height hold functions satisfactorily in the model.
- (ii) While the wind gust disturbs the model, it returns to near its set height in a smooth and reasonable manner. The steady state error which occurs after the disturbance results from the absence of integral action in the control law.
- (iii) Note that the model has a residual roll angle (PHI HE) when flying at 90 kt (46.6 m/s) which causes yaw angle to be non-zero in steady flight at this speed.
- (iv) Points (v) and (vi) of the first test also apply here.

5. CONCLUDING REMARKS

A simplified control systems mathematical model for the Sea King Mk.50 helicopter has been described, with remarks about design philosophy and system construction being included where applicable. To obtain this model, the aircraft's control system has been simplified to its essential control laws, while still retaining all essential sub-systems, for example, beeper trim and open-loop spring functions.

It is expected that the model will suffice for most of the problems likely to be encountered in operating the helicopter. However, if detailed studies were required of a particular portion of the systems, then expansion of that part could be made without altering the effectiveness of the remainder of the model. In addition, straightforward simplifications and linearizations can be made to perform systems analysis work.

Sample results have shown the model of the aircraft with its AFCS and cable to behave in a reasonable manner, although verification of these results through flight trials has not yet been performed.

NOMENCLATURE

ASW P, ASW R	ASW mode output signals
AUTO C, ... P, ... R, ... Y	Autostabilizer/autopilot mode output signals—unlimited
AUTO CL, ... PL, ... RL, ... YL	Autostabilizer/autopilot mode output signals—limited
AIS, BIS	Cyclic blade pitch angles
BAR A, RAD A	Height hold signals (barometric and radio respectively)
CAB P, CAB R	Cable angle error signals
CADO IP, CADO IR	ASW mode integral error signals
CC1, CC16	Constants (collective channel)
CLU A	Clutched collective stick difference signal
CPI, CPI6	Constants (pitch channel)
CR1, CR16	Constants (roll channel)
CY1, CY13	Constants (yaw channel)
D AUX C, D AUX Y	Auxiliary servo output positions
D CABLE	Cable length
DOP P, DOP R	Doppler groundspeed error signals (proportional plus integral)
D PED DT	Rate of change of rudder pedals position
D PEDLS	Rudder pedals position
D PIL Y	Pilot's rudder pedals position
D SPR C, D SPR Y	Open-loop spring linkage positions
EL AC, ... AP, ... AR, ... AY	Autostabilizer/autopilot authority limits
EL BP, EL BR	Beeping limits
EL CP, ... CR, ... CY	Control stop angles
EL MAX, EL MIN	Maximum and minimum collective stick angles respectively
EL OC, EL OY	Open-loop spring compression limits
H COMM	Reference radio altitude (positive upwards)
H HOVER	Set hover height (positive upwards)
H REF	Reference barometric height (positive upwards)
H SET	Set radio height (positive upwards)
MFP1, MFP2, MFR1, MFR2	Cable length dependent gearings
PHI CH, THE CH	Attitude angles of cable relative to helicopter in roll and pitch respectively
PHI ERT, THE ERT	Cable angle error signals (proportional)

PHI HE, PSI HE, THE HE	Attitude angle of helicopter relative to earth in roll, yaw and pitch respectively
PHI PIL, THE PIL	Pilot's cyclic stick angles
PHI STK, THE STK	Cyclic stick angles
PHI TDT, THE TDT	Cyclic stick angle rates of change
PHI TRM, PSI TRM, THE TRM	Trim angle signals in roll, yaw and pitch respectively
PIT TRM, ROL TRM	Windspeed trim signals
PSI ERR	Heading error signal (proportional)
PSI INT	Heading error signal (integral)
PSI PI	Heading error signal (proportional plus integral)
PSI REF	Reference heading signal
R HEH	Yaw rate of helicopter relative to earth
s	Laplace operator
S AFT, S AFT H, S AFT NU	Aft motion beeping switches
S AUTO C, ... P, ... R, ... Y	Autostabilizer/autopilot mode selector switches
S BAR A, S RAD A	Height hold selector switches, barometric and radio respectively
S CAB, S DOP	Mode selector switches, cable and doppler respectively
ST CS PL	Collective stick friction switch
S FWD, S FWD H, S FWD NU	Forward motion beeping switches
S MULT P, S MULT R	Multivibrator signals
S NEG P, S NEG R	Aft motion beeping switches
S PEDLS	Yaw force link switch
S PORT, S PORT H, S PORT NU	Port motion beeping switches
S POS P, S POS R	Forward motion beeping switches
S STBD, S STBD H, S STBD NU	Starboard motion beeping switches
S TRM RL	Cyclic stick trim release switch
t	Time
t_d	Start time for transition down manoeuvre
t_u	Start time for transition up manoeuvre
T CS PL	Pilot's collective stick angle
TC1, TC2	Time constants
TH CS D	Rate of change of collective stick angle
THE CLU	Clutched collective stick angle
THEC ST	Collective stick angle
THETA C, THETA T	Collective blade pitch angles, main and tail rotors respectively
TMP, TMR	'On' period for multivibrator signals
TP1, ... TP3	Time constants

TR1, . . . TR4	Time constants
TSMP, TSMR	Multivibrator signal frequencies
U COMM	Reference longitudinal groundspeed
U ERR	Modified longitudinal groundspeed error signal
U HEH, V HEH	Longitudinal and lateral groundspeeds respectively
U HEH DT, V HEH DT	Longitudinal and lateral accelerations respectively
U SET	Set exit speed
V GVP, V GVR	Smoothed ground velocity signal in pitch and roll respectively
W HEE	Vertical velocity relative to earth
Z ERI	Integral radio altitude error signal
Z HEE	Altitude (positive downwards)

REFERENCES

1. Packer, T. J. Wessex helicopter/sonar dynamics study. Initial report. WRE Technical Note SAD 216, January 1969.
2. Packer, T. J. Wessex helicopter/sonar dynamics study. The mathematical model of the helicopter aerodynamics and kinematics. WRE Technical Memorandum SAD 203, November 1969.
3. Packer, T. J. Wessex helicopter/sonar dynamics study. The mathematical model of the sonar cable and transducer. WRE Report 951 (WR and D), May 1973.
4. Packer, T. J. and Lane, R. C. Wessex helicopter/sonar dynamics study. The system simulation program. WRE Technical Note 937 (WR and D), May 1973.
5. — A.P. (RAN) 300-1-4.1 Chapter 19. Flying Controls.
6. — A.P. (RAN) 300-1-6 Chapter 70-0. Automatic Flight Control System Mk. 31; Automatic Flight Control System—General.
7. — A.P. (RAN) 300-1-6 Chapter 70-1. Automatic Flight Control System Mk. 31; Autostabilizer/Autopilot Mode.
8. — A.P. (RAN) 300-1-6 Chapter 70-2. Automatic Flight Control System Mk. 31; ASW Mode.
9. Collomøsse, H. All-weather operation for helicopters: flight control systems for helicopters. Journal of the Royal Aeronautical Society, Vol. 73, February 1969.

**APPENDIX I: EQUATIONS OF THE SIMPLIFIED CONTROL SYSTEMS
MATHEMATICAL MODEL**

Switch conventions used are: 1 = "on", 0 = "off".

1. FLYING CONTROLS

1.1 Pitch Channel (Fig. 3)

$$BIS = (CPI * THE\ STK) + (AUTO\ PL) \quad (1.1)$$

$$\begin{aligned} \text{If } S\ TRM\ RL = 1 \\ THE\ STK = THE\ PIL \end{aligned} \quad \left. \vphantom{\begin{aligned} \text{If } S\ TRM\ RL = 1 \\ THE\ STK = THE\ PIL \end{aligned}} \right\} (1.2)$$

$$\begin{aligned} \text{If } S\ TRM\ RL = 0 \\ THE\ STK = \int (THE\ TDT)\ dt \end{aligned} \quad \left. \vphantom{\begin{aligned} \text{If } S\ TRM\ RL = 0 \\ THE\ STK = \int (THE\ TDT)\ dt \end{aligned}} \right\} (1.3)$$

$$\begin{aligned} \text{If } |THE\ STK| < |EL\ CP| \\ THE\ STK = THE\ STK \end{aligned} \quad \left. \vphantom{\begin{aligned} \text{If } |THE\ STK| < |EL\ CP| \\ THE\ STK = THE\ STK \end{aligned}} \right\} (1.4)$$

$$\begin{aligned} \text{If } |THE\ STK| \geq |EL\ CP| \\ THE\ STK = |EL\ CP| * SIGN\ THE\ STK \end{aligned} \quad \left. \vphantom{\begin{aligned} \text{If } |THE\ STK| \geq |EL\ CP| \\ THE\ STK = |EL\ CP| * SIGN\ THE\ STK \end{aligned}} \right\} (1.5)$$

1.2 Roll Channel (Fig. 4)

$$AIS = (CRI * PHI\ STK) + (AUTO\ RL) \quad (1.6)$$

$$\begin{aligned} \text{If } S\ TRM\ RL = 1 \\ PHI\ STK = PHI\ PIL \end{aligned} \quad \left. \vphantom{\begin{aligned} \text{If } S\ TRM\ RL = 1 \\ PHI\ STK = PHI\ PIL \end{aligned}} \right\} (1.7)$$

$$\begin{aligned} \text{If } S\ TRM\ RL = 0 \\ PHI\ STK = \int (PHI\ TDT)\ dt \end{aligned} \quad \left. \vphantom{\begin{aligned} \text{If } S\ TRM\ RL = 0 \\ PHI\ STK = \int (PHI\ TDT)\ dt \end{aligned}} \right\} (1.8)$$

$$\begin{aligned} \text{If } |PHI\ STK| < |EL\ CR| \\ PHI\ STK = PHI\ STK \end{aligned} \quad \left. \vphantom{\begin{aligned} \text{If } |PHI\ STK| < |EL\ CR| \\ PHI\ STK = PHI\ STK \end{aligned}} \right\} (1.9)$$

$$\begin{aligned} \text{If } |PHI\ STK| \geq |EL\ CR| \\ PHI\ STK = |EL\ CR| * SIGN\ PHI\ STK \end{aligned} \quad \left. \vphantom{\begin{aligned} \text{If } |PHI\ STK| \geq |EL\ CR| \\ PHI\ STK = |EL\ CR| * SIGN\ PHI\ STK \end{aligned}} \right\} (1.10)$$

1.3 Yaw Channel (Fig. 5)

$$THETA\ T = (CY1 * D\ AUX\ Y) + (CY2) + (CY12 * D\ AUX\ C) \quad (1.11)$$

$$D\ AUX\ Y = CY13 * \int [(CY9 * D\ SPR\ Y) + (CY10 * AUTO\ YL)]\ dt \quad (1.12)$$

$$D\ SPR\ Y = (CY7 * D\ PEDLS) - (CY8 * D\ AUX\ Y) \quad (1.13)$$

$$\begin{aligned} \text{If } |D\ SPR\ Y| < |EL\ OY| \\ D\ PED\ DT = 0 \end{aligned} \quad \left. \vphantom{\begin{aligned} \text{If } |D\ SPR\ Y| < |EL\ OY| \\ D\ PED\ DT = 0 \end{aligned}} \right\} (1.14)$$

$$\begin{aligned} \text{If } |D\ SPR\ Y| \geq |EL\ OY| \\ D\ PED\ DT = -CY11 * (|D\ SPR\ Y| - |EL\ OY|) * SIGN\ D\ SPR\ Y \end{aligned} \quad \left. \vphantom{\begin{aligned} \text{If } |D\ SPR\ Y| \geq |EL\ OY| \\ D\ PED\ DT = -CY11 * (|D\ SPR\ Y| - |EL\ OY|) * SIGN\ D\ SPR\ Y \end{aligned}} \right\} (1.15)$$

$$\begin{aligned} \text{If } PEDLS = 1 \\ D\ PEDLS = D\ PIL\ Y \end{aligned} \quad \left. \vphantom{\begin{aligned} \text{If } PEDLS = 1 \\ D\ PEDLS = D\ PIL\ Y \end{aligned}} \right\} (1.16)$$

$$\begin{aligned} \text{If } S\ PEDLS = 0 \\ D\ PEDLS = \int (D\ PED\ DT)\ dt \end{aligned} \quad \left. \vphantom{\begin{aligned} \text{If } S\ PEDLS = 0 \\ D\ PEDLS = \int (D\ PED\ DT)\ dt \end{aligned}} \right\} (1.17)$$

$$\begin{aligned} \text{If } |D\ PEDLS| < |EL\ CY| \\ D\ PEDLS = D\ PEDLS \end{aligned} \quad \left. \vphantom{\begin{aligned} \text{If } |D\ PEDLS| < |EL\ CY| \\ D\ PEDLS = D\ PEDLS \end{aligned}} \right\} (1.18)$$

$$\left. \begin{aligned} \text{If } |D \text{ PEDLS}| \geq |EL \text{ CY}| \\ D \text{ PEDLS} = |EL \text{ CY}| \cdot \text{SIGN } D \text{ PEDLS} \end{aligned} \right\} (1.19)$$

1.4 Collective Channel (Fig. 6)

$$THETA \text{ C} = (CC1 \cdot D \text{ AUX C}) + (CC2) \quad (1.20)$$

$$D \text{ AUX C} = CC14 \cdot \int [(CC9 \cdot D \text{ SPR C}) + (CC10 \cdot AUTO \text{ CL})] dt \quad (1.21)$$

$$D \text{ SPR C} = CC12 \cdot [THEC \text{ ST} - CC15 \cdot (EL \text{ MAX} + EL \text{ MIN})] - CC8 \cdot D \text{ AUX C} \quad (1.22)$$

$$\left. \begin{aligned} \text{If } |D \text{ SPR C}| < |EL \text{ OC}| \\ TH \text{ CS D} = 0 \end{aligned} \right\} (1.23)$$

$$\left. \begin{aligned} \text{If } |D \text{ SPR C}| \geq |EL \text{ OC}| \\ TH \text{ CS D} = -CC11 \cdot (D \text{ SPR C} - |EL \text{ OC}|) \cdot \text{SIGN } D \text{ SPR C} \end{aligned} \right\} (1.24)$$

$$\left. \begin{aligned} \text{If } SC \text{ ST} = 1 \\ THEC \text{ ST} = T \text{ CS PL} \end{aligned} \right\} (1.25)$$

$$\left. \begin{aligned} \text{If } SC \text{ ST} = 0 \\ THEC \text{ ST} = \int (TH \text{ CS D}) dt \end{aligned} \right\} (1.26)$$

$$\left. \begin{aligned} \text{If } EL \text{ MIN} < THEC \text{ ST} < EL \text{ MAX} \\ THEC \text{ ST} = THEC \text{ ST} \end{aligned} \right\} (1.27)$$

$$\left. \begin{aligned} \text{If } EL \text{ MIN} \geq THEC \text{ ST} \\ THEC \text{ ST} = EL \text{ MIN} \\ \text{or if } EL \text{ MAX} \leq THEC \text{ ST} \\ THEC \text{ ST} = EL \text{ MAX} \end{aligned} \right\} (1.28)$$

2. AFCS AUTOSTABILIZER/AUTOPILOT MODE

2.1 Pitch Channel (Fig. 7)

$$\left. \begin{aligned} \text{If } S \text{ AUTO P} = 1 \\ \text{AUTO P} = (CP2 \cdot THE \text{ STK}) + (CP3 \cdot THE \text{ HE}) + \\ \left(CP4 \cdot \frac{s}{1 + TP1s} \cdot THE \text{ HE} \right) + (ASW \text{ P}) + (THE \text{ TRM}) \end{aligned} \right\} (2.1)$$

$$\left. \begin{aligned} \text{If } S \text{ AUTO P} = 0 \\ \text{AUTO P} = 0 \end{aligned} \right\} (2.2)$$

$$\left. \begin{aligned} \text{If } |AUTO \text{ P}| < |EL \text{ AP}| \\ \text{AUTO PL} = \text{AUTO P} \end{aligned} \right\} (2.3)$$

$$\left. \begin{aligned} \text{If } |AUTO \text{ P}| \geq |EL \text{ AP}| \\ \text{AUTO PL} = |EL \text{ AP}| \cdot \text{SIGN } \text{AUTO P} \end{aligned} \right\} (2.4)$$

2.2 Roll Channel (Fig. 8)

$$\left. \begin{aligned} \text{If } S \text{ AUTO R} = 1 \\ \text{AUTOR} = \left[CR2 \cdot \frac{1 + TR2s}{1 + TR3s} \cdot (\text{PHI TRM} + \text{PHI STK}) \right] - (CR3 \cdot \text{PHI HE}) - \\ \left(CR4 \cdot \frac{s}{1 + TR1s} \cdot \text{PHI HE} \right) + (ASW \text{ R}) \end{aligned} \right\} (2.5)$$

$$\left. \begin{aligned} \text{If } S \text{ AUTO R} = 0 \\ \text{AUTOR} = 0 \end{aligned} \right\} (2.6)$$

$$\left. \begin{aligned} \text{If } |AUTO \text{ R}| < |EL \text{ AR}| \\ \text{AUTO RL} = \text{AUTOR} \end{aligned} \right\} (2.7)$$

$$\left. \begin{aligned} \text{If } |AUTO \text{ R}| \geq |EL \text{ AR}| \\ \text{AUTO RL} = |EL \text{ AR}| \cdot \text{SIGN } \text{AUTO R} \end{aligned} \right\} (2.8)$$

2.3 Yaw Stabilizer and Heading Hold (Fig. 9)

$$\begin{aligned} \text{If } S \text{ AUTO Y} &= 1 \\ \text{AUTO Y} &= (CY3 * R \text{ HEH}) + (\text{PSI PI}) \end{aligned} \quad \left. \vphantom{\begin{aligned} \text{If } S \text{ AUTO Y} &= 1 \\ \text{AUTO Y} &= (CY3 * R \text{ HEH}) + (\text{PSI PI}) \end{aligned}} \right\} (2.9)$$

$$\begin{aligned} \text{If } S \text{ AUTO Y} &= 0 \\ \text{AUTO Y} &= 0 \end{aligned} \quad \left. \vphantom{\begin{aligned} \text{If } S \text{ AUTO Y} &= 0 \\ \text{AUTO Y} &= 0 \end{aligned}} \right\} (2.10)$$

$$\begin{aligned} \text{If } S \text{ PEDLS} &= 1 \\ \text{PSI PI} &= 0 \\ \text{and} \\ \text{PSI INT} &= -CY6 * \int (\text{PSI INT}) dt \end{aligned} \quad \left. \vphantom{\begin{aligned} \text{If } S \text{ PEDLS} &= 1 \\ \text{PSI PI} &= 0 \\ \text{and} \\ \text{PSI INT} &= -CY6 * \int (\text{PSI INT}) dt \end{aligned}} \right\} (2.11)$$

$$\begin{aligned} \text{If } S \text{ PEDLS} &= 0 \\ \text{PSI PI} &= (CY4 * \text{PSI ERR}) + (CY5 * \int (\text{PSI ERR}) dt) \\ \text{where} \end{aligned} \quad \left. \vphantom{\begin{aligned} \text{If } S \text{ PEDLS} &= 0 \\ \text{PSI PI} &= (CY4 * \text{PSI ERR}) + (CY5 * \int (\text{PSI ERR}) dt) \\ \text{where} \end{aligned}} \right\} (2.12)$$

$$\text{PSI ERR} = \text{PSI HE} - \text{PSI TRM} - \text{PSI REF}$$

$$\begin{aligned} \text{If } \text{AUTO Y} &< \text{EL AY} \\ \text{AUTO YL} &= \text{AUTO Y} \end{aligned} \quad \left. \vphantom{\begin{aligned} \text{If } \text{AUTO Y} &< \text{EL AY} \\ \text{AUTO YL} &= \text{AUTO Y} \end{aligned}} \right\} (2.13)$$

$$\begin{aligned} \text{If } \text{AUTO Y} &\geq \text{EL AY} \\ \text{AUTO YL} &= \text{EL AY} * \text{SIGN AUTO Y} \end{aligned} \quad \left. \vphantom{\begin{aligned} \text{If } \text{AUTO Y} &\geq \text{EL AY} \\ \text{AUTO YL} &= \text{EL AY} * \text{SIGN AUTO Y} \end{aligned}} \right\} (2.14)$$

2.4 Barometric Height Hold (Fig. 10)

$$\begin{aligned} \text{If } S \text{ AUTO C} &= 1 \\ \text{AUTO C} &= \text{BAR A} - \text{CLU A} + \text{RAD A} \end{aligned} \quad \left. \vphantom{\begin{aligned} \text{If } S \text{ AUTO C} &= 1 \\ \text{AUTO C} &= \text{BAR A} - \text{CLU A} + \text{RAD A} \end{aligned}} \right\} (2.15)$$

$$\begin{aligned} \text{If } S \text{ AUTO C} &= 0 \\ \text{AUTO C} &= 0 \end{aligned} \quad \left. \vphantom{\begin{aligned} \text{If } S \text{ AUTO C} &= 0 \\ \text{AUTO C} &= 0 \end{aligned}} \right\} (2.16)$$

$$\begin{aligned} \text{If } S \text{ BAR A} &= 1 \\ \text{BAR A} &= \text{CC3} * \left(\frac{\text{Z HEE} - \text{H REF}}{1 - \text{TCIs}} \right) \end{aligned} \quad \left. \vphantom{\begin{aligned} \text{If } S \text{ BAR A} &= 1 \\ \text{BAR A} &= \text{CC3} * \left(\frac{\text{Z HEE} - \text{H REF}}{1 - \text{TCIs}} \right) \end{aligned}} \right\} (2.17)$$

$$\begin{aligned} \text{where} \\ \text{H REF} &= \text{Z HEE at time when } S \text{ BAR A is engaged} \end{aligned}$$

$$\begin{aligned} \text{If } S \text{ BAR A} &= 0 \\ \text{BAR A} &= 0 \\ \text{and } \text{H REF} &= \text{Z HEE} \end{aligned} \quad \left. \vphantom{\begin{aligned} \text{If } S \text{ BAR A} &= 0 \\ \text{BAR A} &= 0 \\ \text{and } \text{H REF} &= \text{Z HEE} \end{aligned}} \right\} (2.18)$$

$$\begin{aligned} \text{If } S \text{ BAR A or } S \text{ RAD A} &= 1 \\ \text{CLU A} &= \text{CC13} * (\text{THEC ST} - \text{THE CLU}) \\ \text{where} \\ \text{THE CLU} &= \text{THEC ST at time when } S \text{ BAR A} \\ &\quad \text{or } S \text{ RAD A is engaged} \end{aligned} \quad \left. \vphantom{\begin{aligned} \text{If } S \text{ BAR A or } S \text{ RAD A} &= 1 \\ \text{CLU A} &= \text{CC13} * (\text{THEC ST} - \text{THE CLU}) \\ \text{where} \\ \text{THE CLU} &= \text{THEC ST at time when } S \text{ BAR A} \\ &\quad \text{or } S \text{ RAD A is engaged} \end{aligned}} \right\} (2.19)$$

$$\begin{aligned} \text{If } S \text{ BAR A and } S \text{ RAD A} &= 0 \\ \text{CLU A} &= 0 \\ \text{and } \text{THE CLU} &= \text{THEC ST} \end{aligned} \quad \left. \vphantom{\begin{aligned} \text{If } S \text{ BAR A and } S \text{ RAD A} &= 0 \\ \text{CLU A} &= 0 \\ \text{and } \text{THE CLU} &= \text{THEC ST} \end{aligned}} \right\} (2.20)$$

$$\begin{aligned} \text{If } \text{AUTO C} &< \text{EL AC} \\ \text{AUTO CL} &= \text{AUTO C} \end{aligned} \quad \left. \vphantom{\begin{aligned} \text{If } \text{AUTO C} &< \text{EL AC} \\ \text{AUTO CL} &= \text{AUTO C} \end{aligned}} \right\} (2.21)$$

$$\begin{aligned} \text{If } \text{AUTO C} &\geq \text{EL AC} \\ \text{AUTO CL} &= \text{EL AC} * \text{SIGN AUTO C} \end{aligned} \quad \left. \vphantom{\begin{aligned} \text{If } \text{AUTO C} &\geq \text{EL AC} \\ \text{AUTO CL} &= \text{EL AC} * \text{SIGN AUTO C} \end{aligned}} \right\} (2.22)$$

3. AFCS ASW MODE

3.1 Pitch Channel (Fig. 11)

$$\text{ASW P} = \text{DOP P} + \text{CAB P} \quad (3.1)$$

3.1.1 Transitions and doppler hover

$$\begin{aligned}
 &\text{If } S \text{ DOP} = 1 \\
 &\text{DOP P} = [\text{CP5} * (\text{U COMM} - \text{V GVP})] - (\text{CADO IP}) \\
 &\text{and} \\
 &\text{CADO IP} = \text{CP6} * \int \left(\text{U HEH} - \frac{\text{U COMM}}{1 + \text{TP2s}} \right) dt \\
 &\text{where} \\
 &\text{V GVP} = \frac{1}{1 + \text{TP3s}} (\text{CP17} * \text{U HEH DT} + \text{CP18} * \text{U HEH}) \\
 &\text{U COMM} = \text{U HEH}_{t-t_d} * \left[1 - \left(\frac{t-t_d}{\text{CP7}} \right) \right] \text{ when } t_d \leq t \leq t_d + 78s. \\
 &\text{U COMM} = 0 \quad \text{when } t_d + 78s < t < t_u \\
 &\text{and} \\
 &\text{U COMM} = \text{U SET} * \left(\frac{t-t_u}{\text{CP7}} \right) \quad \text{when } t_u \leq t \leq t_u + 78s. \\
 &(\text{Note that } \text{U HEH}_{t-t_d} \text{ is the value of U HEH at } t = t_d.) \\
 &\text{If } S \text{ DOP} = 0 \\
 &\text{DOP P} = 0 \quad \text{and} \\
 &\text{CADO IP} = -\text{CP10} * \int (\text{CADO IP}) dt
 \end{aligned} \tag{3.2}$$

3.1.2 Cable hover

$$\begin{aligned}
 &\text{If } S \text{ CAB} = 1 \\
 &\text{CAB P} = [\text{MFP2} * (\text{THE CH} + \text{THE HE} + \text{PIT TRM})] - \\
 &\quad \left(\text{CP9} * \frac{\text{U HEH DT}}{1 + \text{TP3s}} \right) - (\text{CADO IP}) \\
 &\text{and} \\
 &\text{CADO IP} = -\text{MFP1} * \int (\text{THE CH} + \text{THE HE} + \text{PIT TRM}) dt \\
 &\text{where} \\
 &\text{MFP1} = (\text{CP13} * \text{D CABLE}) + \text{CP14} \\
 &\text{and} \\
 &\text{MFP2} = (\text{CP15} * \text{D CABLE}) + \text{CP16} \\
 &\text{If } S \text{ CAB} = 0 \\
 &\text{CAB P} = 0 \quad \text{and} \\
 &\text{CADO IP} = -\text{CP10} * \int (\text{CADO IP}) dt
 \end{aligned} \tag{3.4}$$

3.2 Roll Channel (Fig. 12)

$$\text{ASW R} = \text{DOP R} + \text{CAB R} \tag{3.6}$$

3.2.1 Transitions and doppler hover

$$\begin{aligned}
 &\text{If } S \text{ DOP} = 1 \\
 &\text{DOP R} = -(\text{CR5} * \text{V GVR}) - (\text{CADO IR}) \\
 &\text{where} \\
 &\text{CADO IR} = \text{CR6} * \int (\text{V HEH}) dt \\
 &\text{and} \\
 &\text{V GVR} = \frac{1}{1 + \text{TR4s}} (\text{CR17} * \text{V HEH DT} + \text{CR18} * \text{V HEH}) \\
 &\text{If } S \text{ DOP} = 0 \\
 &\text{DOP R} = 0 \quad \text{and} \\
 &\text{CADO IR} = -\text{CR10} * \int (\text{CADO IR}) dt
 \end{aligned} \tag{3.7}$$

$$\tag{3.8}$$

3.2.2 Cable hover

$$\begin{aligned} \text{If } S_{CAB} = 1 \\ \text{CAB R} = - [\text{MFR2} * (\text{PHI CH} + \text{PHI HE} + \text{ROL TRM})] - \\ \left(\text{CR9} * \frac{\text{V HEH DT}}{1 + \text{TR4s}} \right) - (\text{CADO IR}) \end{aligned} \quad \left. \vphantom{\begin{aligned} \text{If } S_{CAB} = 1 \\ \text{CAB R} = - [\text{MFR2} * (\text{PHI CH} + \text{PHI HE} + \text{ROL TRM})] - \right.} \right\} (3.9)$$

and

$$\text{CADO IR} = \text{MFR1} * \int (\text{PHI CH} + \text{PHI HE} + \text{ROL TRM}) dt$$

where

$$\text{MFR1} = (\text{CR13} * \text{D CABLE}) + \text{CR14} \quad \text{and}$$

$$\text{MFR2} = (\text{CR15} * \text{D CABLE}) + \text{CR16}$$

$$\begin{aligned} \text{If } S_{CAB} = 0 \\ \text{CAB R} = 0 \quad \text{and} \\ \text{CADO IR} = - \text{CR10} * \int (\text{CADO IR}) dt \end{aligned} \quad \left. \vphantom{\begin{aligned} \text{If } S_{CAB} = 0 \\ \text{CAB R} = 0 \quad \text{and} \\ \text{CADO IR} = - \text{CR10} * \int (\text{CADO IR}) dt \end{aligned}} \right\} (3.10)$$

3.3 Radio Altitude Hold (Fig. 13)

$$\begin{aligned} \text{If } S_{\text{RAD A}} = 1 \\ \text{RAD A} = [\text{CC4} * (\text{Z HEE} + \text{H COMM})] + (\text{CC5} * \text{W HEE}) + (\text{CC6} * \text{Z ERI}) \\ \text{and} \\ \text{Z ERI} = \int \left(\text{Z HEE} + \frac{\text{H COMM}}{1 + \text{TC2s}} \right) dt \end{aligned} \quad \left. \vphantom{\begin{aligned} \text{If } S_{\text{RAD A}} = 1 \\ \text{RAD A} = [\text{CC4} * (\text{Z HEE} + \text{H COMM})] + (\text{CC5} * \text{W HEE}) + (\text{CC6} * \text{Z ERI}) \\ \text{and} \\ \text{Z ERI} = \int \left(\text{Z HEE} + \frac{\text{H COMM}}{1 + \text{TC2s}} \right) dt \end{aligned}} \right\} (3.11)$$

where

$$\text{H COMM} = \text{H SET} \quad \text{when } t < t_d \text{ and } t > t_u + 78s$$

$$\text{H COMM} = \text{H HOVER} + (\text{H SET} - \text{H HOVER}) * \left[1 - \left(\frac{t - t_d}{\text{CC15}} \right) \right] \quad \text{when } t_d \leq t \leq t_d + 62s$$

$$\text{H COMM} = \text{H HOVER} \quad \text{when } t_d + 62s < t < t_u + 16s$$

and

$$\text{H COMM} = \text{H HOVER} + \left[(\text{H SET} - \text{H HOVER}) * \left(\frac{t - t_u - \text{CC16}}{\text{CC15}} \right) \right] \quad \text{when } t_u + 16s \leq t \leq t_u + 78s$$

$$\begin{aligned} \text{If } S_{\text{RAD A}} = 0 \\ \text{RAD A} = 0 \\ \text{and} \\ \text{Z ERI} = \int \left[\left(\text{Z HEE} + \frac{\text{H COMM}}{1 + \text{TC2s}} \right) - (\text{CC7} * \text{Z ERI}) \right] dt \end{aligned} \quad \left. \vphantom{\begin{aligned} \text{If } S_{\text{RAD A}} = 0 \\ \text{RAD A} = 0 \\ \text{and} \\ \text{Z ERI} = \int \left[\left(\text{Z HEE} + \frac{\text{H COMM}}{1 + \text{TC2s}} \right) - (\text{CC7} * \text{Z ERI}) \right] dt \end{aligned}} \right\} (3.12)$$

3.4 Beeper Trim System

3.4.1 Pitch channel (Fig. 14)

$$\begin{aligned} \text{If } \text{ASW P} \geq \text{EL BP} \\ \text{S POS P} = 1 \\ \text{and } \text{S NEG P} = 0 \end{aligned} \quad \left. \vphantom{\begin{aligned} \text{If } \text{ASW P} \geq \text{EL BP} \\ \text{S POS P} = 1 \\ \text{and } \text{S NEG P} = 0 \end{aligned}} \right\} (3.13)$$

$$\begin{aligned} \text{If } |\text{ASW P}| < |\text{EL BP}| \\ \text{S POS P} = 0 \\ \text{and } \text{S NEG P} = 0 \end{aligned} \quad \left. \vphantom{\begin{aligned} \text{If } |\text{ASW P}| < |\text{EL BP}| \\ \text{S POS P} = 0 \\ \text{and } \text{S NEG P} = 0 \end{aligned}} \right\} (3.14)$$

$$\begin{aligned} \text{If } \text{ASW P} \leq -\text{EL BP} \\ \text{S POS P} = 0 \\ \text{and } \text{S NEG P} = 1 \end{aligned} \quad \left. \vphantom{\begin{aligned} \text{If } \text{ASW P} \leq -\text{EL BP} \\ \text{S POS P} = 0 \\ \text{and } \text{S NEG P} = 1 \end{aligned}} \right\} (3.15)$$

$$\begin{aligned} \text{If } \text{S POS P} \text{ and } \text{S MULT P} = 1 \\ \text{S FWD H} = 1 \end{aligned} \quad \left. \vphantom{\begin{aligned} \text{If } \text{S POS P} \text{ and } \text{S MULT P} = 1 \\ \text{S FWD H} = 1 \end{aligned}} \right\} (3.16)$$

$$\begin{aligned} \text{If } \text{S POS P} \text{ or } \text{S MULT P} = 0 \\ \text{S FWD H} = 0 \end{aligned} \quad \left. \vphantom{\begin{aligned} \text{If } \text{S POS P} \text{ or } \text{S MULT P} = 0 \\ \text{S FWD H} = 0 \end{aligned}} \right\} (3.17)$$

If S NEG P and S MULT P = 1
S AFT H = 1 } (3.18)

If S NEG P or S MULT P = 0
S AFT H = 0 } (3.19)

If S DOP or S CAB = 1
S FWD NU = S FWD H
and S AFT NU = S AFT H } (3.20)

If S DOP or S CAB = 0
S FWD NU = S FWD
and S AFT NU = S AFT } (3.21)

If S FWD NU = 1
THE TDT = CPI1 } (3.22)

If S FWD NU = 0
THE TDT = 0 } (3.23)

If S AFT NU = 1
THE TDT = -CPI2 } (3.24)

If S AFT NU = 0
THE TDT = 0 } (3.25)

3.4.2 Roll channel (Fig. 15)

If ASW R \geq EL BR
S POS R = 1
and S NEG R = 0 } (3.26)

If ASW R < EL BR
S POS R = 0
and S NEG R = 0 } (3.27)

If ASW R \leq -EL BR
S POS R = 0
and S NEG R = 1 } (3.28)

If S POS R and S MULT R = 1
S STBD H = 1 } (3.29)

If S POS R or S MULT R = 0
S STBD H = 0 } (3.30)

If S NEG R and S MULT R = 1
S PORT H = 1 } (3.31)

If S NEG R or S MULT R = 0
S PORT H = 0 } (3.32)

If S DOP or S CAB = 1
S STBD NU = S STBD H
and S PORT NU = S PORT H } (3.33)

If S DOP or S CAB = 0
S STBD NU = S STBD
and S PORT NU = S PORT } (3.34)

If S STBD NU = 1
PHI TDT = CRI1 } (3.35)

If S STBD NU = 0
PHI TDT = 0 } (3.36)

If S PORT NU = 1
PHI TDT = -CR12

} (3.37)

If S PORT NU = 0
PHI TDT = 0

} (3.38)

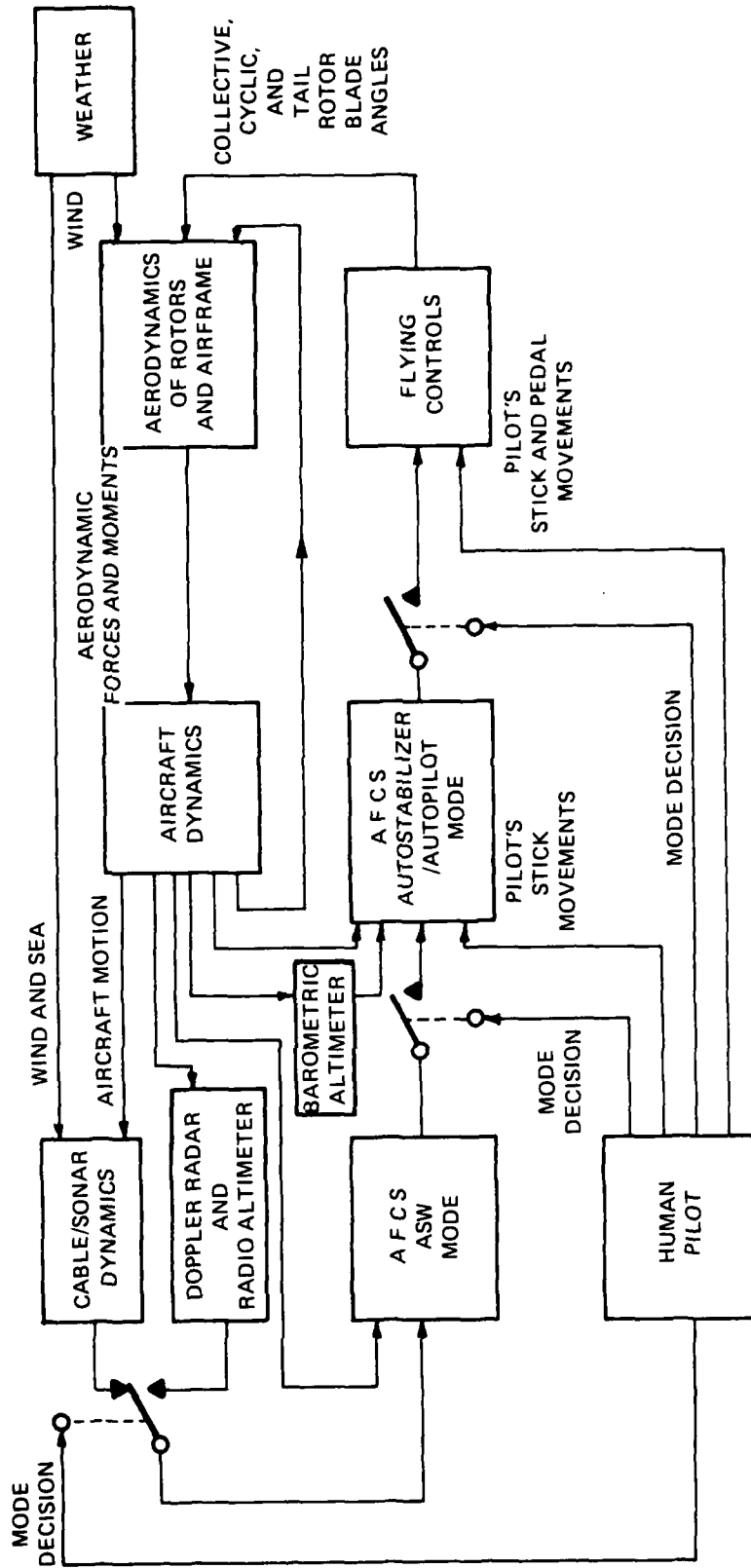

FIG 1. OVERALL BLOCK DIAGRAM FOR THE HELICOPTER/SONAR SYSTEM MODEL

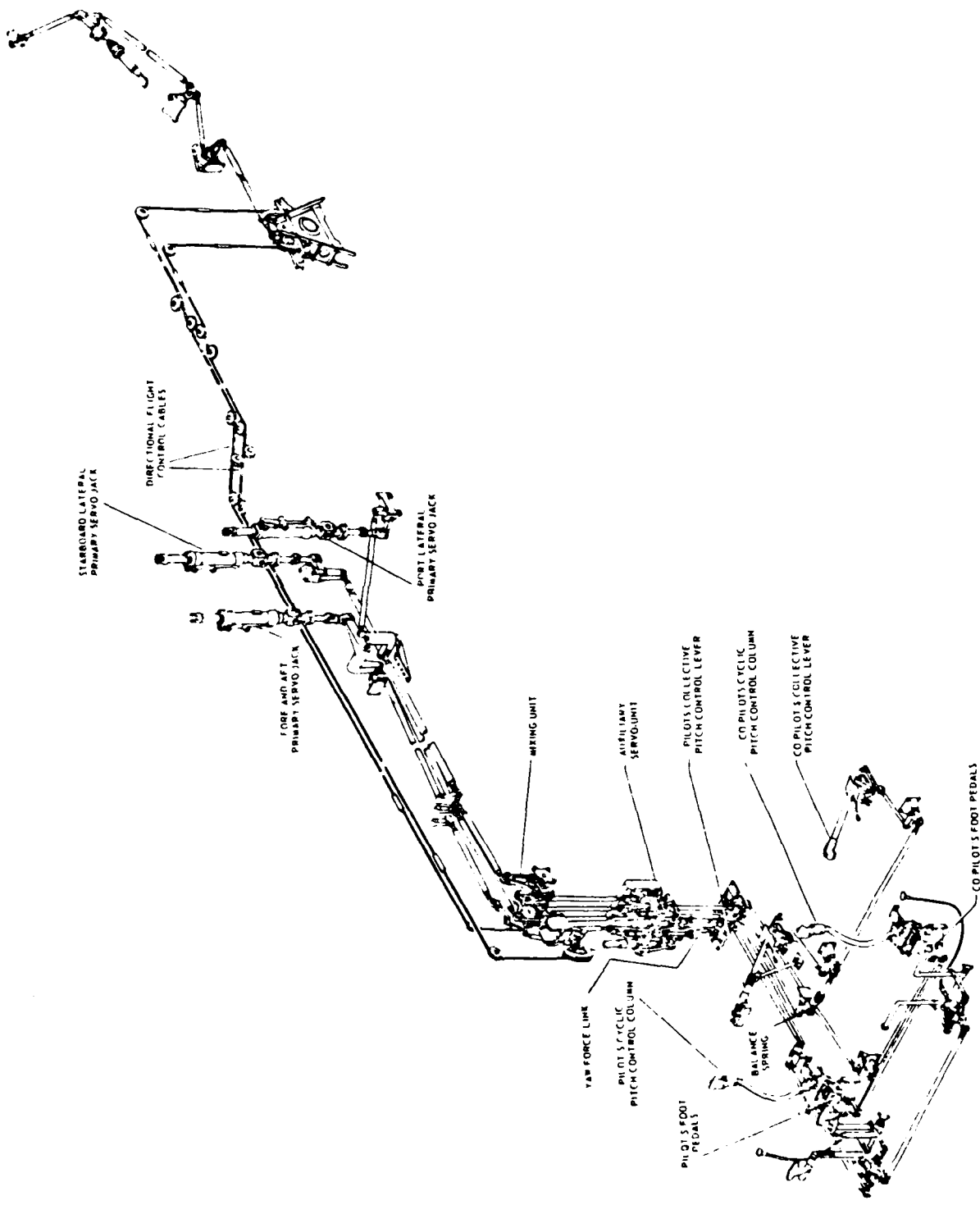

FIG 2. AIRCRAFT FLYING CONTROLS (taken from ref 5)

Key to switch positions:
 ○---▽ 'ON'
 ○---▼ 'OFF'

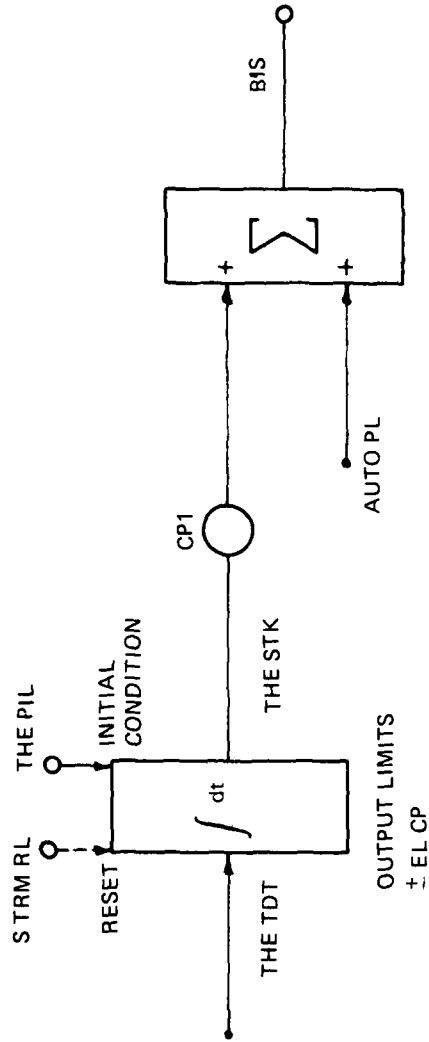

FIG 3. FLYING CONTROLS (PITCH CHANNEL)

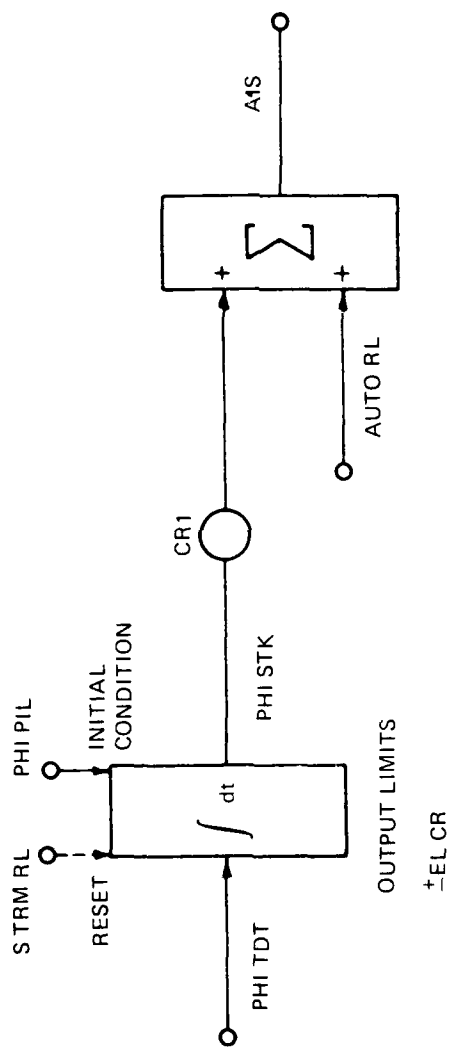

FIG 4. FLYING CONTROLS (ROLL CHANNEL)

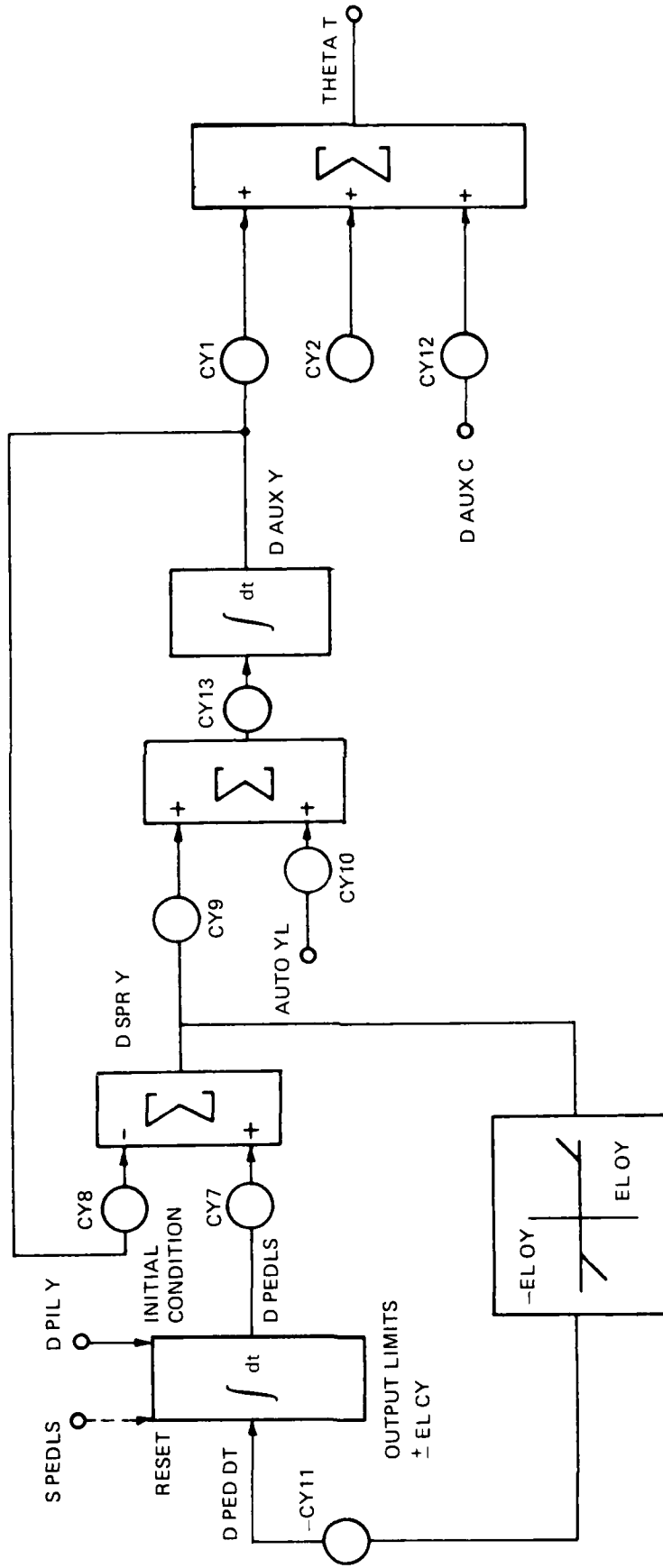

FIG 5. FLYING CONTROLS (YAW CHANNEL)

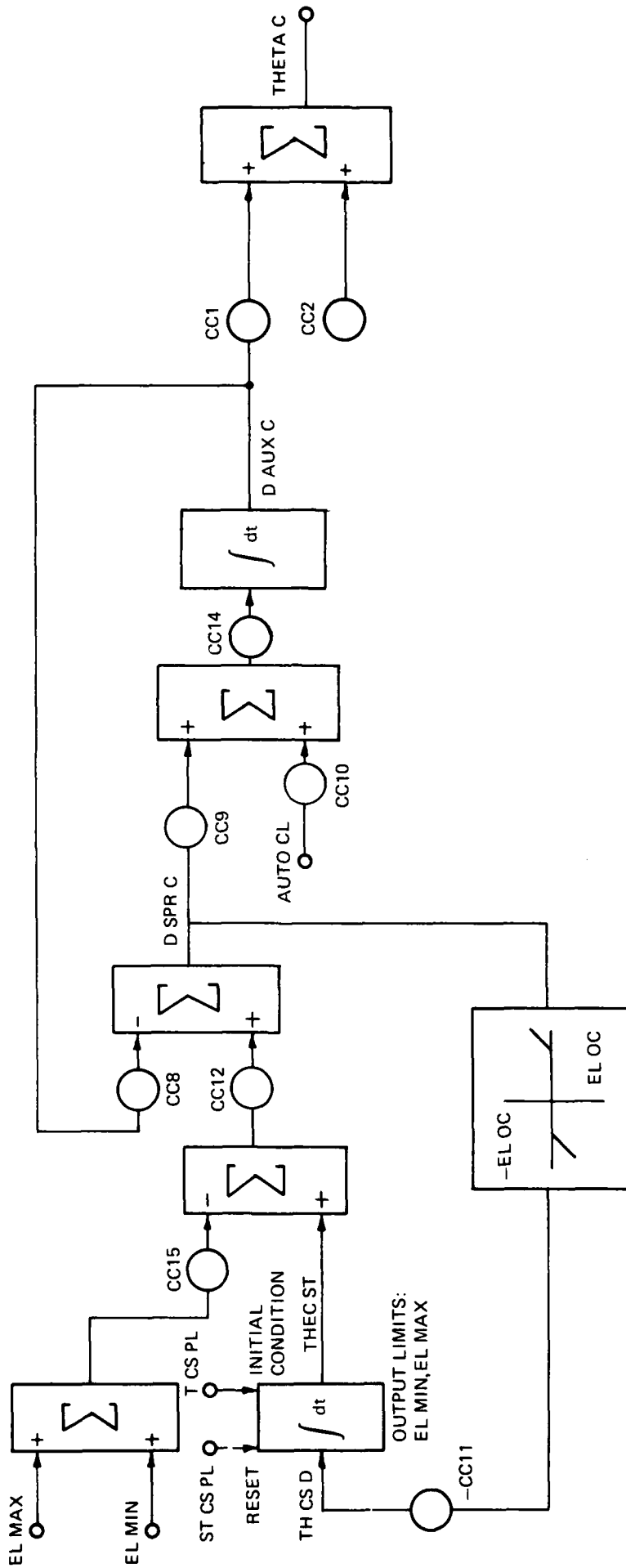

FIG 6. FLYING CONTROLS (COLLECTIVE CHANNEL)

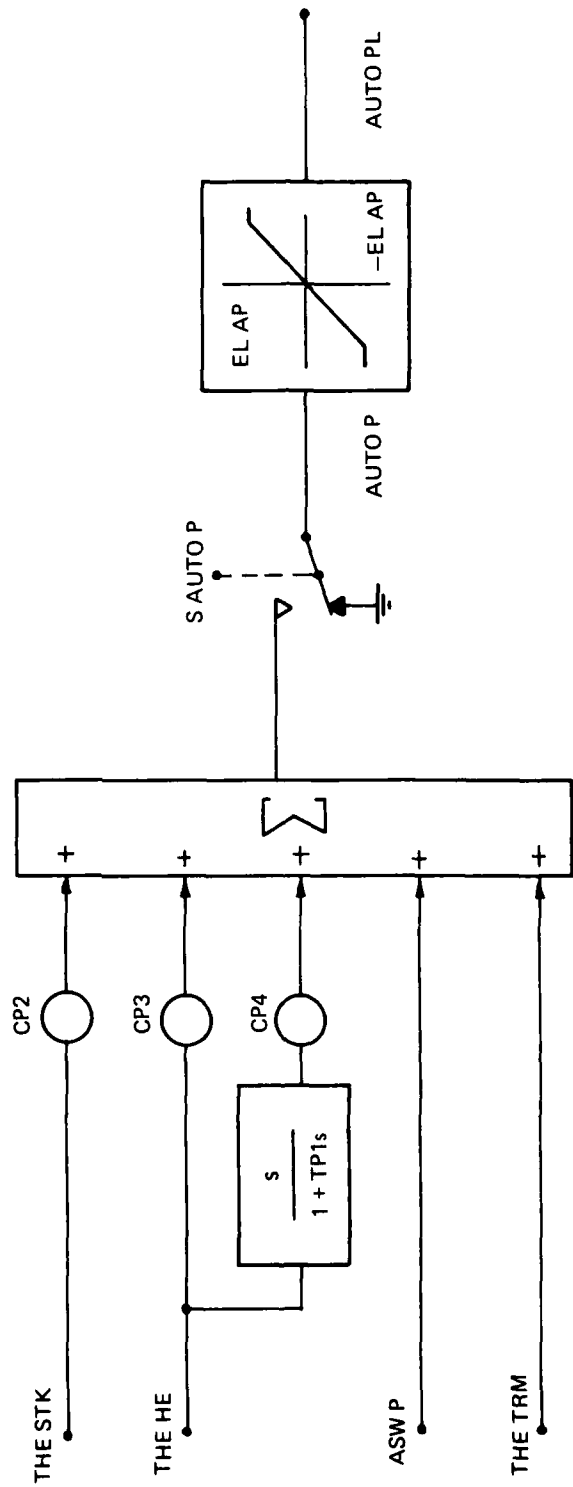

FIG 7. AFCS AUTOSTABILIZER/AUTOPILOT MODE (PITCH CHANNEL)

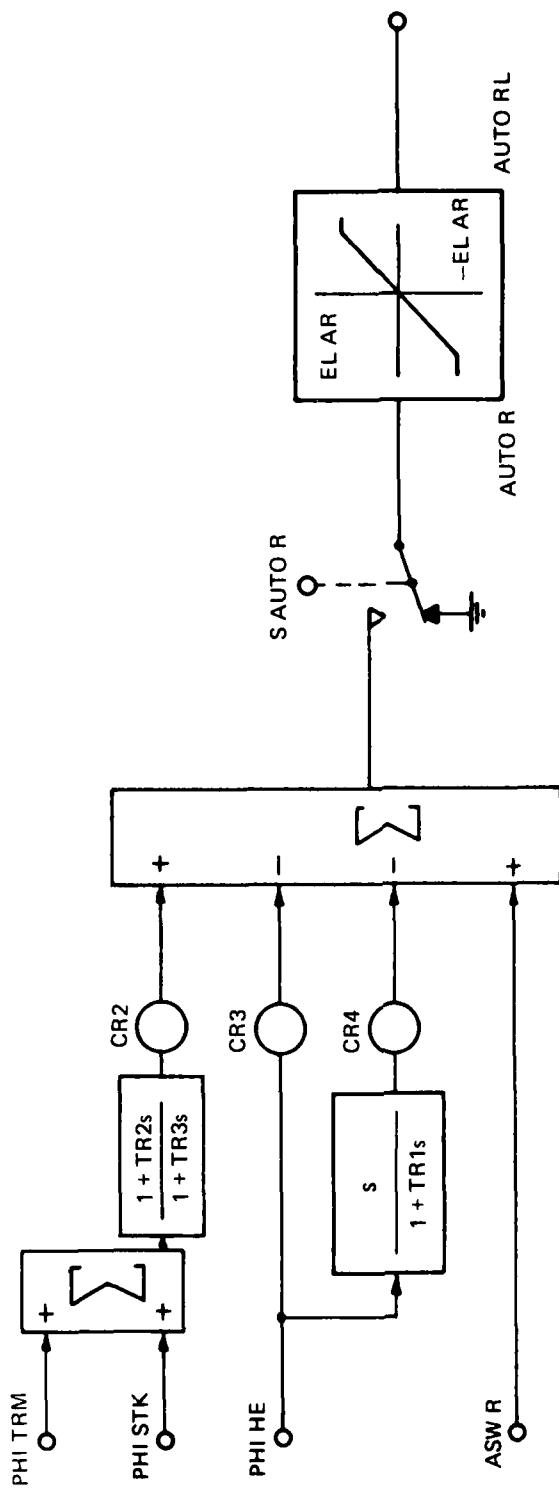

FIG 8. AFCS AUTOSTABILIZER/AUTOPILOT MODE (ROLL CHANNEL)

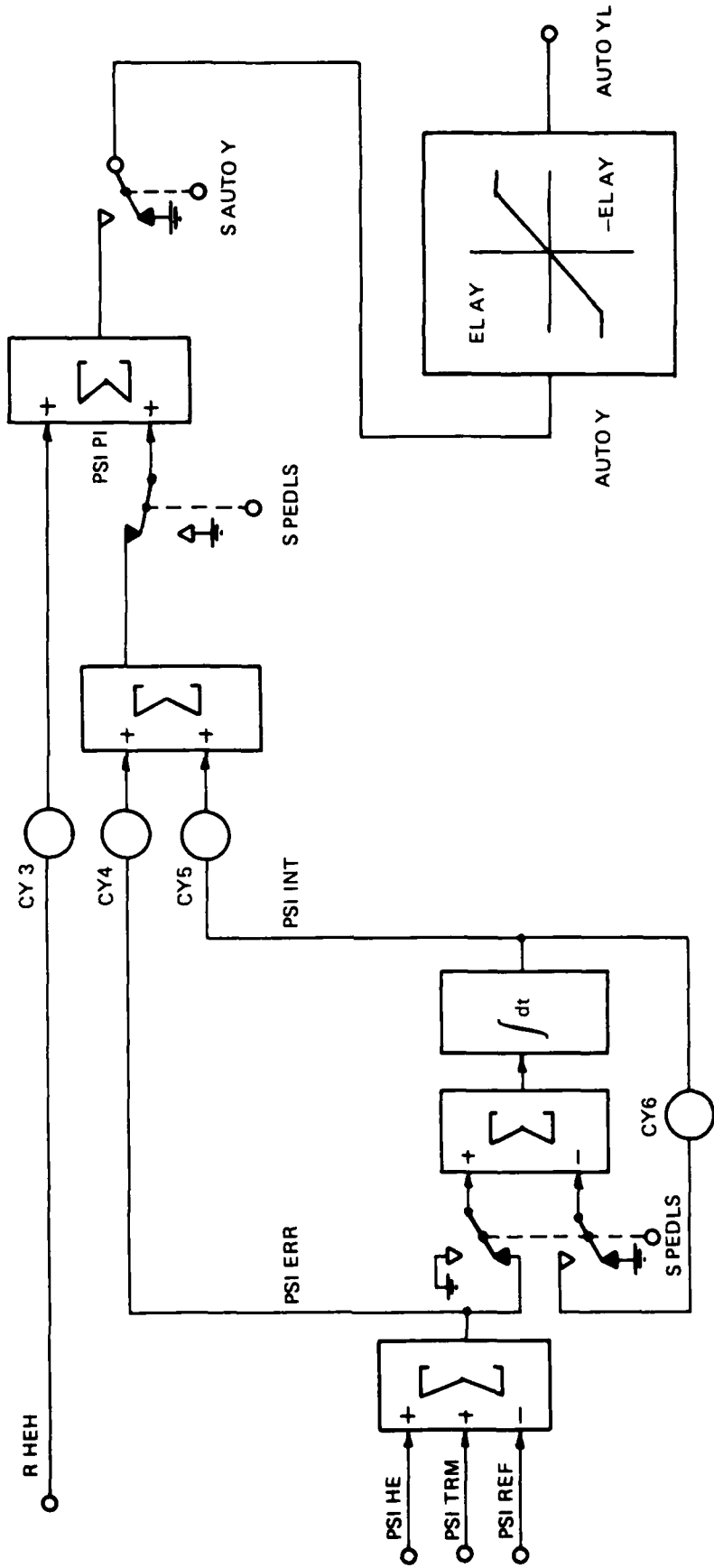

FIG 9. AFCS AUTOSTABILIZER/AUTOPILOT MODE (YAW STABILIZER AND HEADING HOLD)

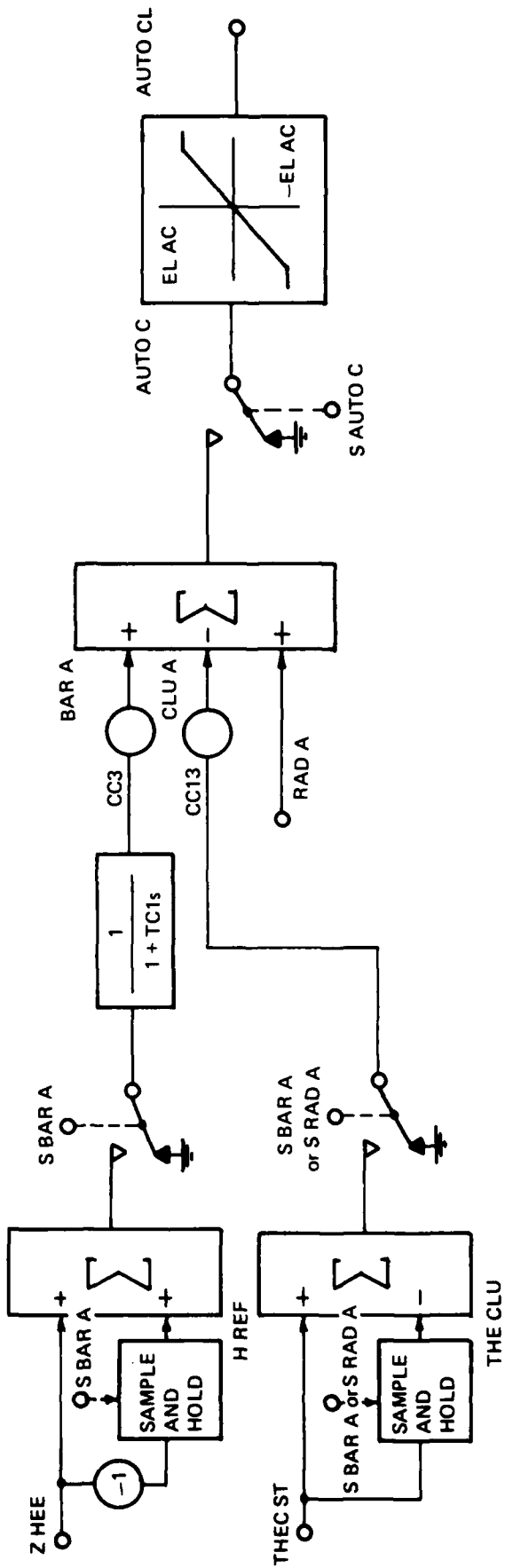

FIG 10. AFCS AUTOSTABILIZER/AUTOPILOT MODE (BAROMETRIC HEIGHT HOLD)

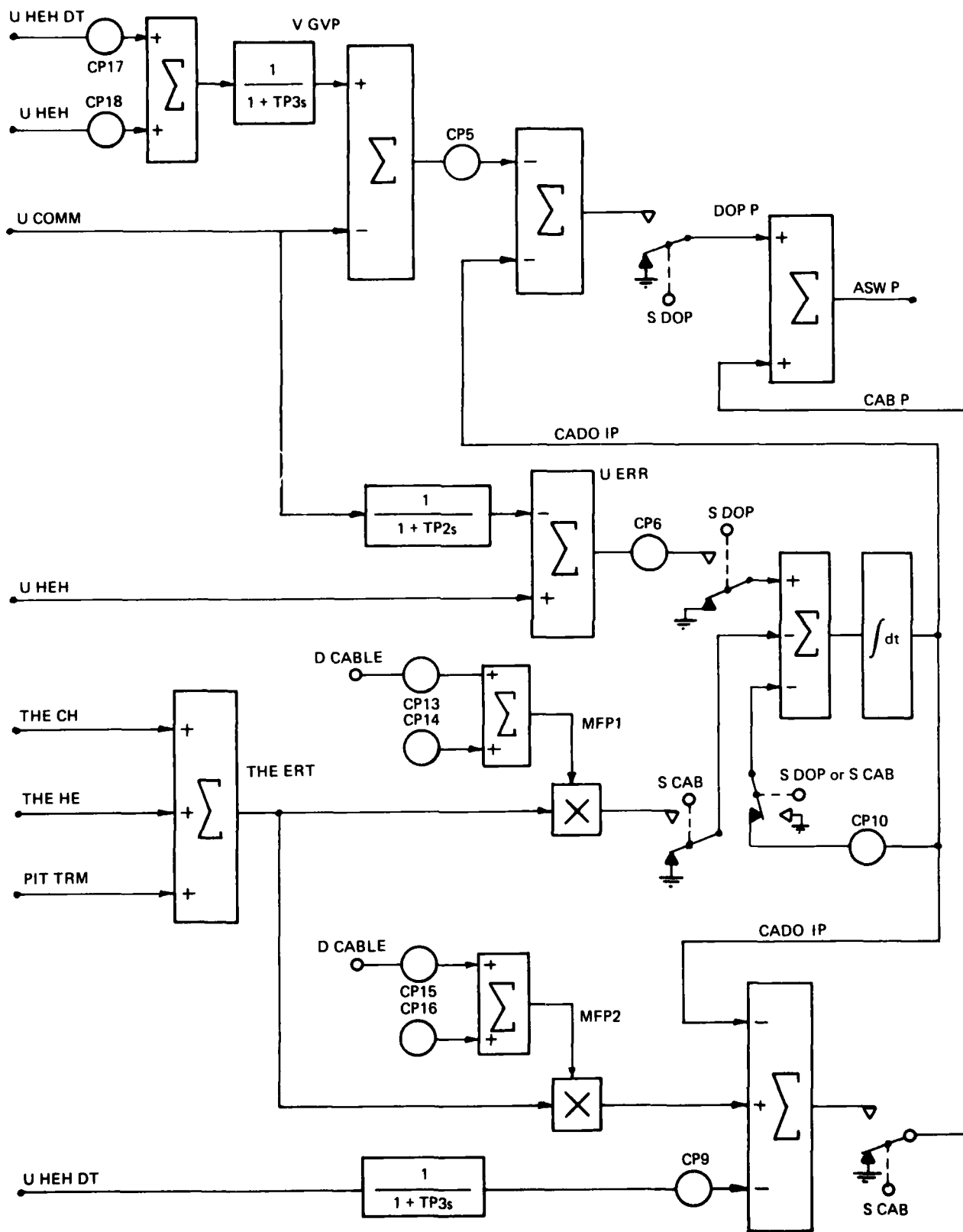

FIG 11. AFCS ASW MODE (PITCH CHANNEL)

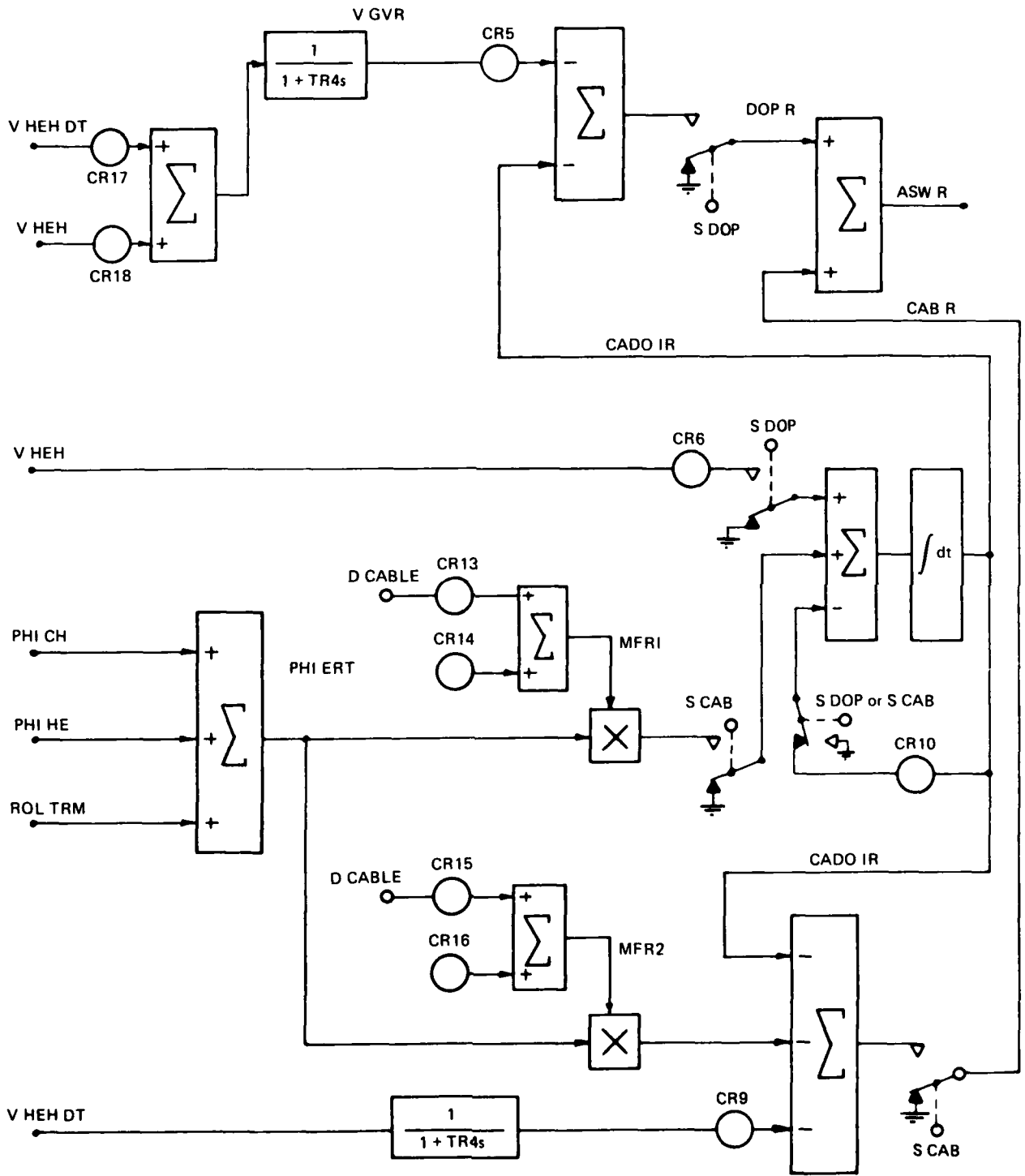

FIG 12. AFCS ASW MODE (ROLL CHANNEL)

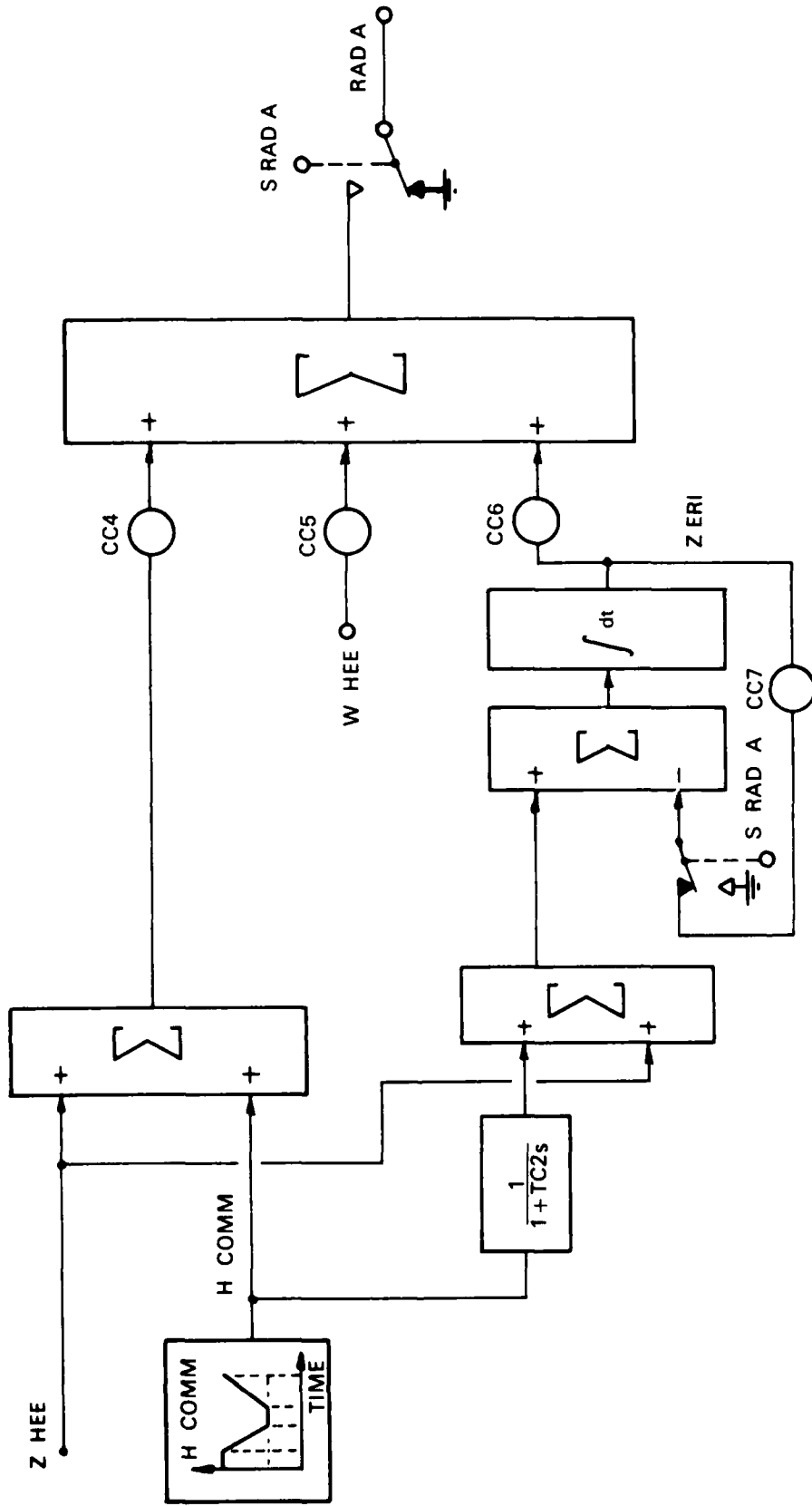

FIG 13. AFCS ASW MODE (RADIO ALTITUDE HOLD)

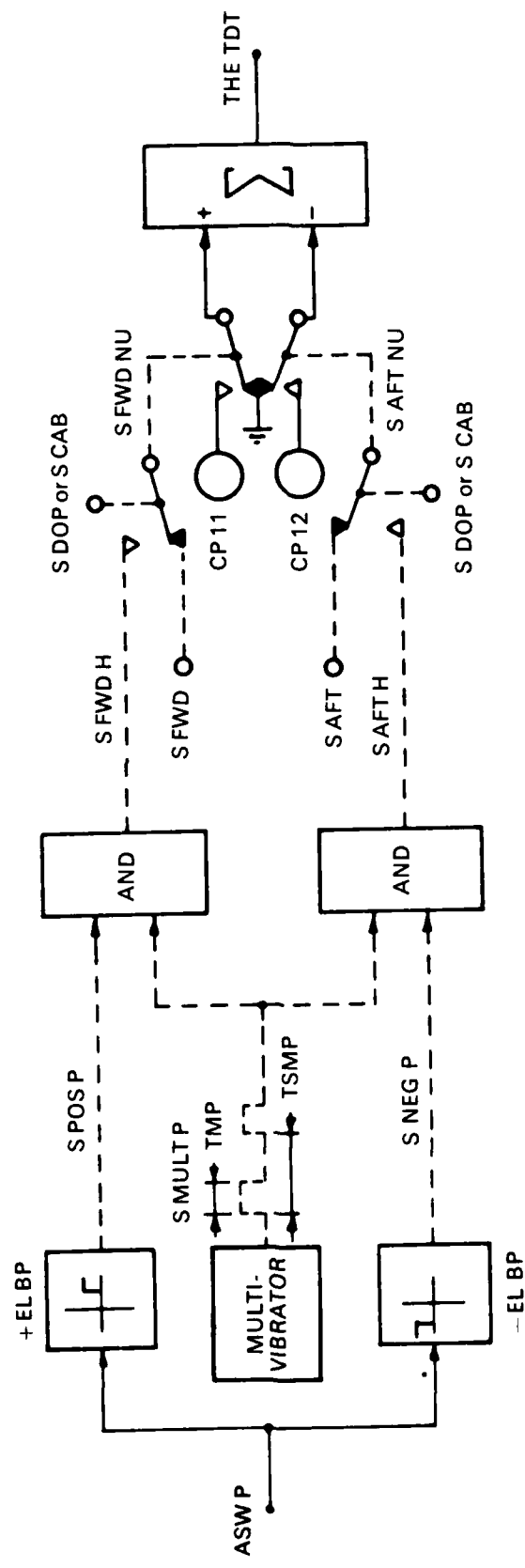

FIG 14. BEEPER TRIM SYSTEM (PITCH CHANNEL)

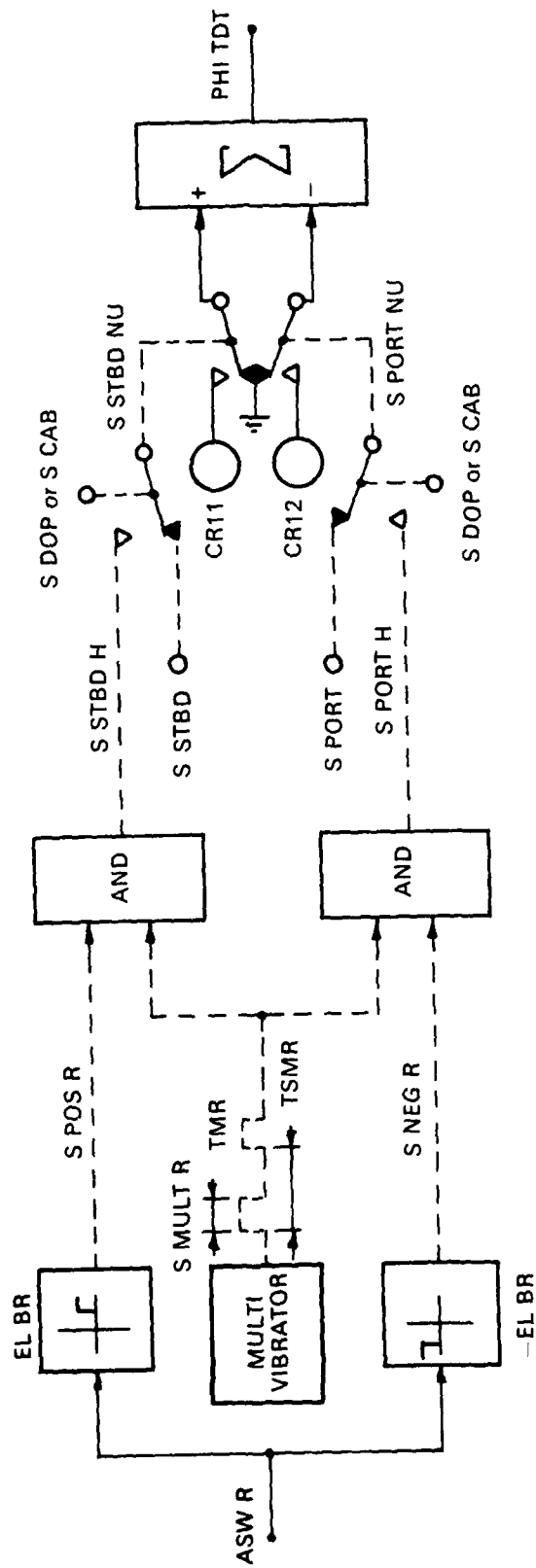
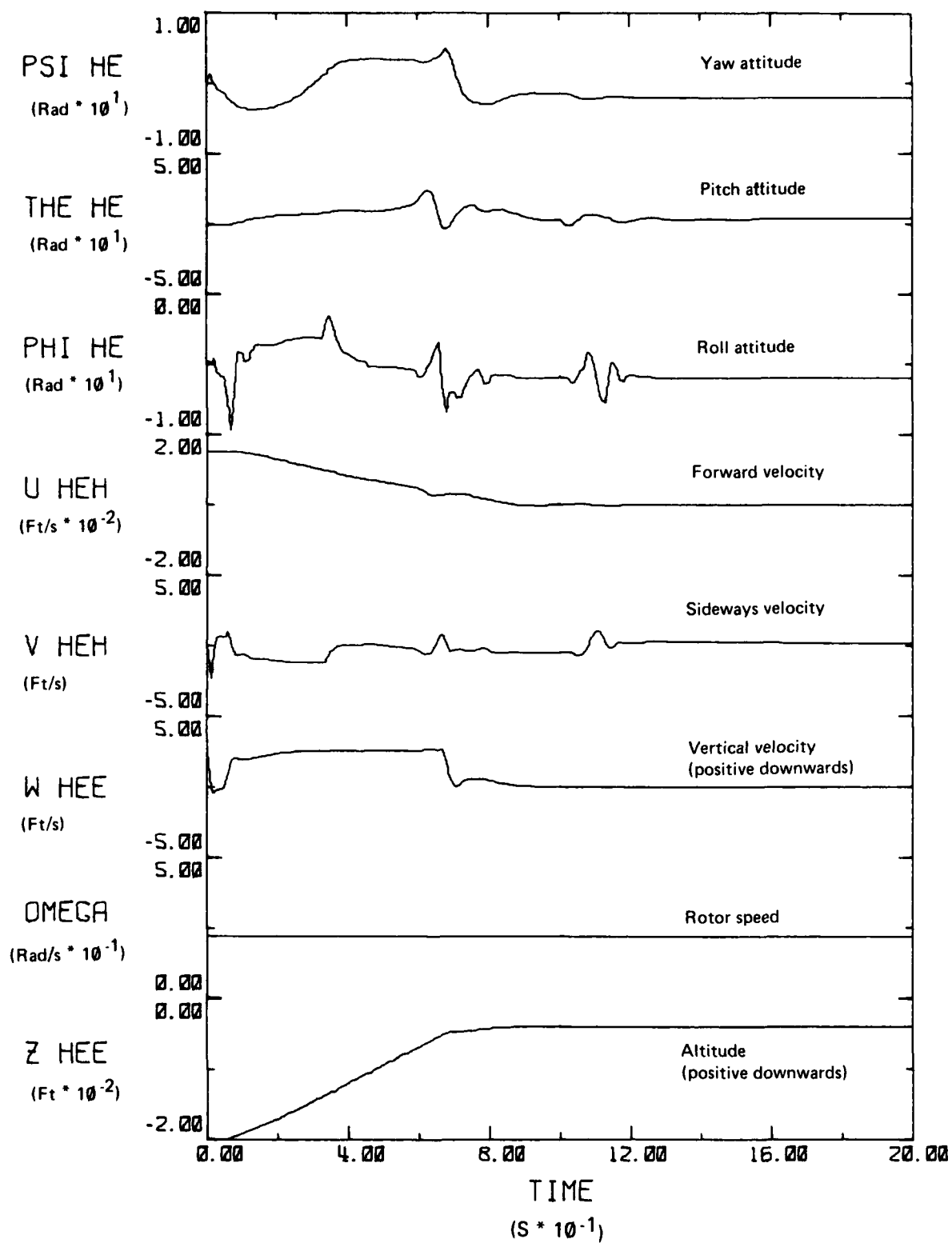
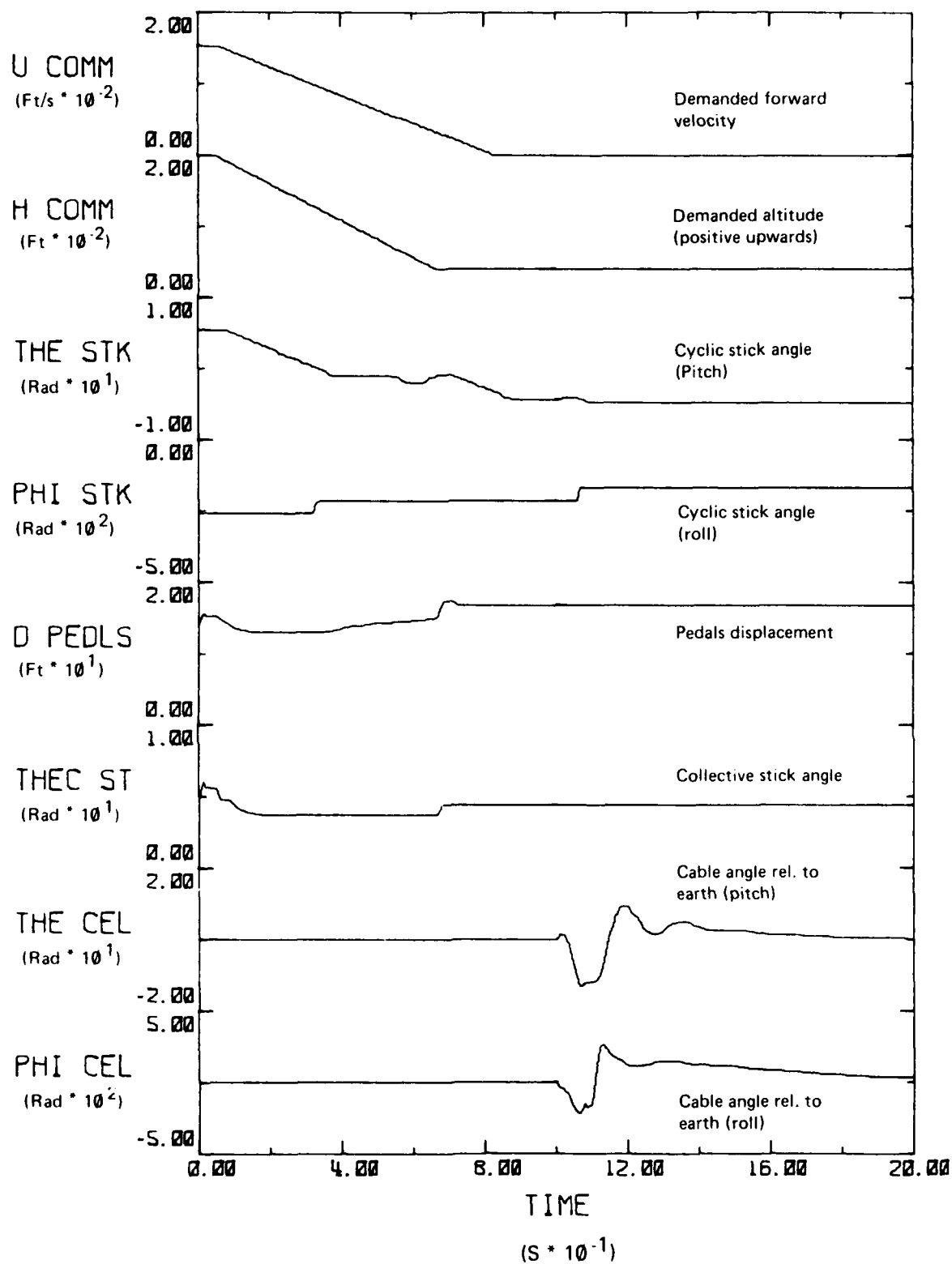

FIG 15. BEEPER TRIM SYSTEM (ROLL CHANNEL)



SEA KING PROGRAM -- CRUISE INITIAL CONDITIONS

FIG 16A. TIME HISTORIES FOR VARIABLES (TEST 1)



SEA KING PROGRAM -- CRUISE INITIAL CONDITIONS

FIG 16B. TIME HISTORIES FOR VARIABLES (TEST 1)

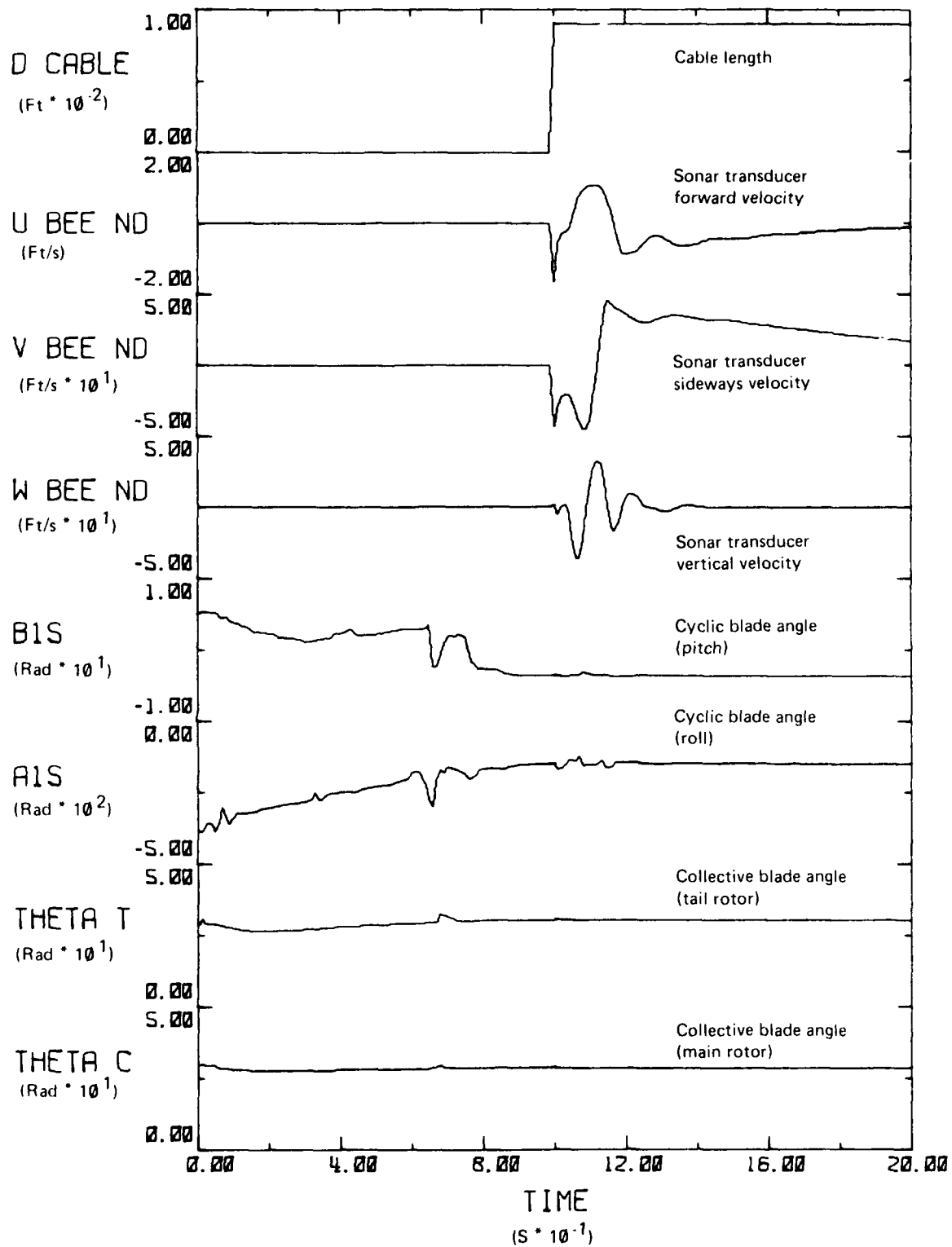

SEA KING PROGRAM -- CRUISE INITIAL CONDITIONS

FIG 16C. TIME HISTORIES FOR VARIABLES (TEST 1)

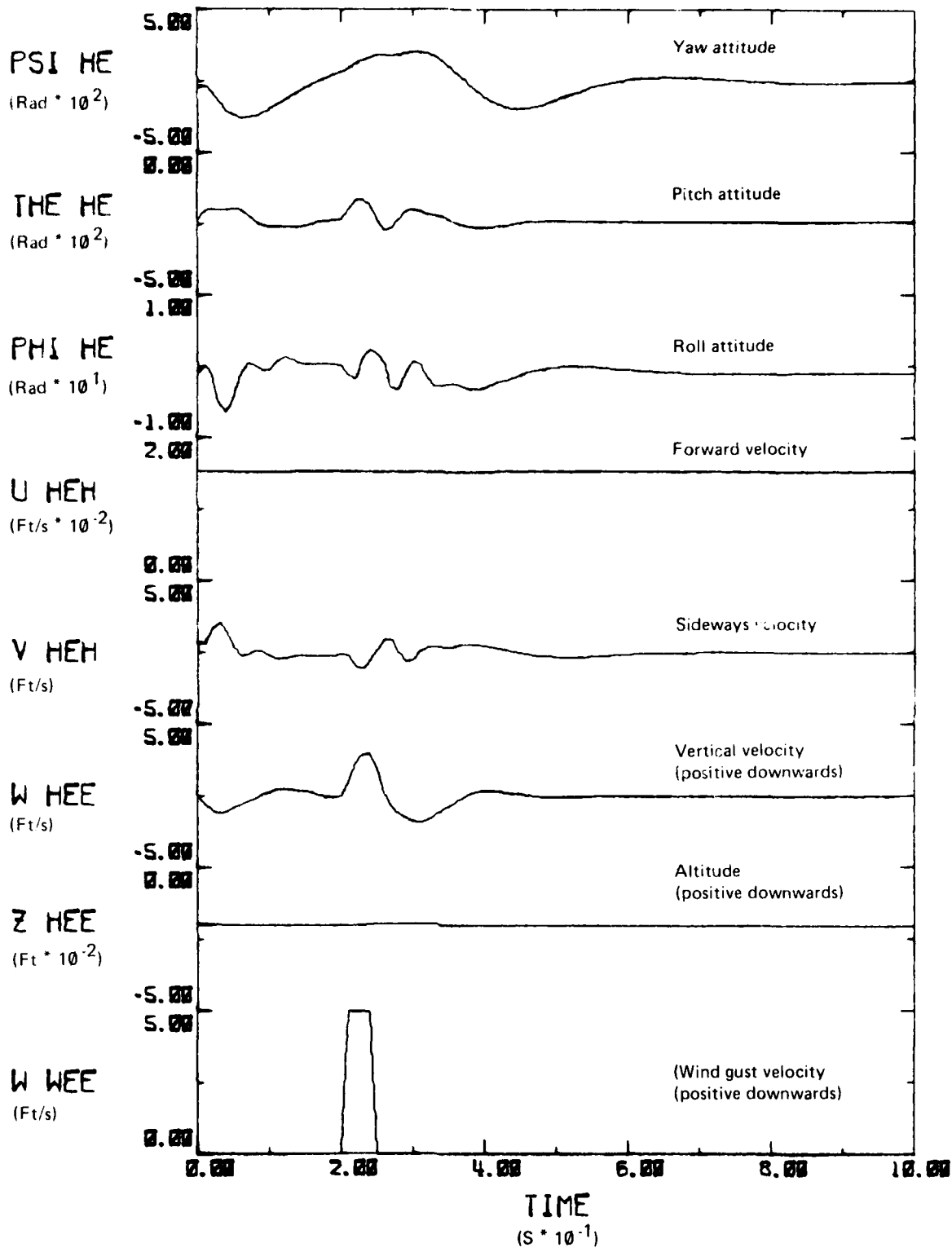

SEA KING PROGRAM - CRUISE I.C.'S OF 90 KTS AND 200FT

FIG 17. TIME HISTORIES FOR VARIABLES (TEST 2)

DISTRIBUTION

	Copy No.
AUSTRALIA	
Department of Defence	
Central Office	
Chief Defence Scientist	1
Deputy Chief Defence Scientist	2
Superintendent, Science and Technology Programs	3
Australian Defence Scientific and Technical Representative (U.K.)	4
Counsellor, Defence Science (U.S.A.)	5
Defence Library	6
Joint Intelligence Organisation	7
Assistant Secretary, D.I.S.B.	8-23
Aeronautical Research Laboratories	
Chief Superintendent	24
Library	25
Superintendent, Aerodynamics Division	26
Divisional File, Aerodynamics Division	27
Author: C. R. Guy	28-29
D. C. Collis	30-33
D. A. Secomb	34
D. E. Hatton	35
Materials Research Laboratories	
Library	36
Defence Research Centre Salisbury	
Library	37
Central Studies Establishment	
Information Centre	38
Engineering Development Establishment	
Library	39
RAN Research Laboratory	
Library	40
Navy Office	
Naval Scientific Adviser	41
Director, Naval Aircraft Engineering	42
Director, Naval Aviation Policy	43
AMAFTU, Nowra	44
Army Office	
Army Scientific Adviser	45
U.S. Army Standardisation Group	46
Royal Military College Library	47
Air Force Office	
Aircraft Research and Development Unit	48
Air Force Scientific Adviser	49

Engineering (CAFTS) Library	50
D. Air Eng.-AF	51
HQ Support Command (SENGSO)	52
Department of Productivity	
Government Aircraft Factories	
Manager/Library	53
Department of Transport	
Secretary/Library	54
Statutory, State Authorities and Industry	
Commonwealth Aircraft Corporation, Manager	55
Hawker de Havilland Pty Ltd, Librarian, Bankstown	56
Universities and Colleges	
Sydney Professor G. A. Bird	57
RMIT Mr H. Millicer	58
CANADA	
NRC, National Aeronautical Establishment, Library	59
FRANCE	
AGARD, Library	60
ONERA, Library	61
Service de Documentation, Technique de l'Aeronautique	62
INDIA	
National Aeronautical Laboratory, Director	63
Hindustan Aeronautics Ltd, Library	64
NETHERLANDS	
National Aerospace Laboratory (NLR) Library	65
UNITED KINGDOM	
Aeronautical Research Council, Secretary	66
Royal Aircraft Establishment Library, Farnborough	67
Royal Aircraft Establishment Library, Bedford	68
Westland Helicopters Ltd	69
UNITED STATES OF AMERICA	
NASA Scientific and Technical Information Facility	70
American Institute of Aeronautics and Astronautics	71
Spares	72-86