

Research Note 80-16

LEVEL II

①

ADA 087016

PERSONNEL REQUIREMENTS CONSIDERATION IN
MAJOR WEAPON SYSTEM ACQUISITION
Research Planning Report
Final Report

March 1980

DTIC
ELECTE
JUL 18 1980
S D
E

DDC FILE COPY

DISTRIBUTION STATEMENT A
Approved for public release;
Distribution Unlimited

McFann - Gray & Associates Inc.

80 7 8 0..9

PERSONNEL REQUIREMENTS CONSIDERATION IN
MAJOR WEAPON SYSTEM ACQUISITION
Research Planning Report
Final Report

By
Fred L. Finch
Kay E. Rigg
Burl B. Gray, Ph.D.

The views, opinions, and findings contained
in this report are those of the author(s)
and should not be construed as an official
Department of the Army position, policy, or
decision, unless so designated by other
official documentation.

March 1980

Contract #MDA903-79-C-0277

Monitored Technically By

Dr. James L. Raney
Army Research Institute
Alexandria, VA

CONTRACT NUMBER: MDA903-79-C-0277
MGA 0978

CONTRACT EXPIRATION DATE: 11 March 1980

PROGRAM TITLE: Personnel Requirement Consideration in Major
Weapon System Acquisition

CONTRACTOR: McFann - Gray & Associates, Inc.

PROJECT DIRECTOR: Kay E. Rigg

PHONE NUMBER: 408/373-1111

DELIVERABLE: 0002AG

Accession For	
NTIS GRA&I <input checked="" type="checkbox"/>	
DDC TAB <input type="checkbox"/>	
Unannounced <input type="checkbox"/>	
Justification <input type="checkbox"/>	
By _____	
Distribution/	
Availability Codes	
Dist	Avail and/or special
A	

REPORT DOCUMENTATION PAGE		READ INSTRUCTIONS BEFORE COMPLETING FORM
1. REPORT NUMBER Research Note 80-16 ✓	2. GOVT ACCESSION NO. AD-A087 016	3. RECIPIENT'S CATALOG NUMBER
4. TITLE (and Subtitle) Personnel Requirements Consideration in Major Weapon System Acquisition, Research Planning Report, Final Report		5. TYPE OF REPORT & PERIOD COVERED Final Report. March 1979 - March 1980
7. AUTHOR(s) Fred L. Finch Kay E. Rigg Burl B. Gray, Ph.D.		8. CONTRACT OR GRANT NUMBER(s) MDA903-79-C-0277
9. PERFORMING ORGANIZATION NAME AND ADDRESS McFann Gray & Associates Inc. ✓ 2100 Garden Road Suite J Monterey, California 93940 411855 (16)		10. PROGRAM ELEMENT, PROJECT, TASK AREA & WORK UNIT NUMBERS 291611Q2B74F
11. CONTROLLING OFFICE NAME AND ADDRESS Army Research Institute for the Behavioral and Social Studies (ARI)		12. REPORT DATE March 1980 (12/45)
13. PERFORMING ORGANIZATION ADDRESS 5001 Eisenhower Avenue (15) ARI Alexandria, Virginia 22333 (19) 1-1-15		13. NUMBER OF PAGES 93
		15. SECURITY CLASS. (of this report) Unclassified
		15a. DECLASSIFICATION/DOWNGRADING SCHEDULE
16. DISTRIBUTION STATEMENT (of this Report) Approved for public release; distribution unlimited.		
17. DISTRIBUTION STATEMENT (of the abstract entered in Block 20, if different from Report)		
18. SUPPLEMENTARY NOTES		
19. KEY WORDS (Continue on reverse side if necessary and identify by block number) Aptitudes Job Analysis Attributes Task Analysis Human Factors		
20. ABSTRACT (Continue on reverse side if necessary and identify by block number) The objective of this effort was to produce a plan of research for develop- ment of a model and methodology for deriving a direct relationship between aptitude measures and task analysis procedures early in the process of weapon system research, development, and acquisition. A literature review indicated that past attempts to link behavioral require- ments with human attributes have not been successful. A recent effort → 2017		

111-55

43

↓
suggested further that these approaches are ultimately not feasible. That effort, as with all the others reviewed, would require a highly specialized and lengthy application for most tasks in every job in every new system and for each phase within the system. Such procedures are slow and expensive. There is a need for a procedure which can be applied in a direct and simple manner.

The current effort has resulted in a research plan based upon a conceptual design for a branching decision logic that will provide measures of personnel requirements while avoiding detailed analysis of nonrelevant factors. Implementation of this plan will result in construction and pilot testing of a computer based branching decision logic in 1980-81 and field testing and evaluation in 1981-82. ↙

Finch, F.L., Rigg, K.E. and Gray, B.B.

Personnel Requirements Consideration in Major Weapon System Acquisition
Research Planning Report, Final Report.

Requirement:

To provide a plan of research for development of a model and methodology for deriving a direct relationship between aptitude measures and task analysis procedures early in the process of weapon system research, development and acquisition.

Procedure:

Task analysis methods currently used in industry and the military were reviewed and analyzed. The methods used for determining personnel requirements associated with development of the Infantry Fighting Vehicle, (IFV), were studied. The IFV contractor and military personnel were interviewed to produce a history of the human factors problems associated with IFV development.

Findings:

The analysis of current personnel prediction methods suggested that they are frequently so complex as to be impractical except where they are so general as to be unusable. Given this situation, it became obvious that there is a need for a simple, yet usable, procedure for identifying personnel requirements. A model for relating psychological and behavioral attributes to work tasks was developed and a preliminary prototypical

system was created. This system applies microcomputer technology to allow the job analyst and/or system designer to consider relevant attributes without a need to consider attributes which do not pertain to the job or task of interest.

Utilization of Findings:

The next steps are to expand and develop the prototype system by creating a hierarchical structure for job-related human attributes and then developing a branching computer program which allows the job analyst or system designer to identify relevant attributes associated with a specific weapon system, job or task. After pilot-testing, the system will be field-tested, evaluated and revised as necessary to produce an operational system.

FOREWORD

The research planning effort was conducted by the Monterey Regional Office of McFann•Gray & Associates, Inc., under contract number MDA903-79-C-0277. Dr. Howard McFann was the project manager, and Mr. Kay Rigg was the project director. The contracting officer's representative was Dr. James Raney.

The research plan resulting from this effort was based largely on data supplied to the project by Dr. Raney and by the FMC Corporation human factors staff directed by Mr. John Justice.

TABLE OF CONTENTS

FOREWORD i

I. INTRODUCTION

A. Purpose and Scope 1

 1. Objective 1

 2. Overview 1

 3. Definitions 3

B. Review of Literature 5

C. Analysis of a New Weapon System in the
Advanced Stage of Development 9

 1. History of Infantry Fighting Vehicle (XM-2)
Development 9

 2. Personnel Requirements Issues 9

II. METHODS

A. Purpose and Scope 11

B. Implementation 15

 1. Develop Computer-Assisted Job Analysis Programs 15

 2. Investigate Methods of Describing Jobs 15

 3. Field-Test the Job Analysis Programs 17

III. SUMMARY OF PROPOSED RESEARCH AND DEVELOPMENT

A. Plan Summary for Year 2 20

B. Plan Summary for Years 3-5 21

REFERENCES 23

APPENDIX A = Personnel Exemplars

APPENDIX B = Sample Personnel Requirements Scales for the
Preliminary Prototypical Program

APPENDIX C = Job Descriptions

 Introduction

 Section 1. Job-oriented Descriptions

 Section 2. Worker-oriented Job Descriptions

 Section 3. Job Illustrations

LIST OF TABLES

TABLE 1.	Sampling Design	18
TABLE 2.	Example of Random Presentation of Jobs and Paired Job Descriptions	19

LIST OF FIGURES

FIGURE 1.	Personnel Requirements Branching Scales	4
FIGURE 2.	Personnel Exemplar Branching Network	13

PERSONNEL REQUIREMENTS CONSIDERATION IN
MAJOR WEAPON SYSTEM ACQUISITION
Research Planning Report
Final Report

I. INTRODUCTION

A. PURPOSE AND SCOPE

1. Objective

To provide a plan of research for development of a model and methodology for deriving a direct relationship between aptitude measures and task analysis procedures early in the process of weapon system research, development, and acquisition.

2. Overview

There has been a steady interest in developing a means for relating psychological or behavioral attributes to work tasks. The prototypical paradigm is a matrix with tasks on one margin and attributes, aptitudes and/or skills on the other. In this case, the task is identified and the required aptitudes or behavioral skills are listed. Efforts to develop

such matrices have become hopelessly enmeshed in hundreds of tasks with the intrusion of "situational" variables, and frequently low statistical relationships between job inventory data and actual performance. The result has been schemes characterized by such complexity as to make them unusable for practical purposes.

There is a need for some procedure which can be applied in a direct and simple manner. This procedure should enable systems designers to ask questions regarding the personnel requirements of a proposed task or job and to receive a direct, straightforward answer. For example, (a) How easy (hard) will it be to find people who can, within a reasonable time, be trained to operate this equipment?, and (b) How easy (hard) will it be to find people who can be trained, within a reasonable time, to maintain this equipment?

System designers do not now ask these questions primarily because there are few methods available which can give an answer; they do not lack interest in the problem. Those few methods which do exist are cumbersome, and frequently provide excessive detail concerning one factor or attribute domain, and no information pertaining to other equally important human attributes.

The investigation of a methodology for scaling and describing human attributes leads to consideration of the equally important question: what is the best way to describe a job? The issue of job descriptions arises because the job analyst's ability to provide information concerning human attributes is limited or enhanced by the quality of information provided by the job description.

The literature research led to the formulation of preliminary models for describing work and predicting requirements for human performance. Further research should simultaneously investigate two issues:

1. What human attributes are required to adequately describe the prerequisites for adequate job performance?
2. How must jobs be described in order to allow the job incumbent, job analyst, or human factors engineer to understand the relevant performance requirements?

The literature review also indicates that past attempts to link behavioral requirements (task analysis) with human attributes (aptitudes)

have not been successful. A recent effort suggests further that the approach is ultimately not feasible. This effort by Dunlap & Associates (1979), dealing directly with personnel requirement considerations in a major weapon system acquisition, failed to provide a solution to the problem. This effort, as with all the others reviewed, would require a highly specialized and lengthy application for most tasks in every job in every new system and for each phase within the system. Such procedures are too slow, too extensive, and too expensive.

There seems to be another approach which circumvents complex task/apptitude linkages while still providing for the early introduction and consideration of personnel requirement constraints and demands. This report describes an approach which can be applied in a fairly direct and simple manner. It should enable systems designers to receive direct straightforward answers to questions regarding the personnel requirements of a proposed task or job.

3. Definitions

One problem of job analysis methodology and the study of human attributes is disparate terminology. Different researchers use different terms to describe similar attributes. Alternatively, different researchers use similar terms to describe different attributes. This discussion is presented to clarify the terms used in this report.

Dunnette (1976, p. 475) defines aptitude, achievement, performance, ability, skill, proficiency, and other terms in great detail. He concludes by stating, "Perhaps the reader by now suspects that this is all part of a tedious joke. If so, the point is made. No truly satisfying closure can be derived from efforts to define these terms." An effort must be made, however, to define certain terms so that communication is made possible.

Anastasi (in Dunnette, 1976, p. 474) states that aptitude denotes performance that "reflects the cumulative influence of multiplicity of experiences in daily living." Dunnette describes skills as including both physical and motor aptitudes and abilities. In Dunnette's view,

" . . . an individual's aptitudes and abilities *both* involve descriptions of current performance, with aptitudes encompassing more general patterns of performance and abilities being more specific. The person may have high verbal *aptitude*; with specialized training, his public speaking *ability* may become very great. (1976, p. 474)"

In addition to human factors, the hierarchical organization of work must be considered. The structure found in the U.S. Employment Service's excellent guide, the Dictionary of Occupational Titles (DOT) has been used for this, as well as for other definitions. To relate the DOT structure to military requirements, the following is used:

1. Industry - military service;
2. Occupation - military occupational specialty;
3. Job or duty - specific assignment;
4. Task - specific performance requirement;
5. Task element - the smallest unit of work.

B. REVIEW OF LITERATURE

"In Greenwich, in 1796, Maskelyne . . . dismissed Kinnebrook, his assistant, because Kinnebrook observed the times of stellar transits almost a second later than he did." (Boring, 1957, p. 134) Bessel read of Kinnebrook's untimely firing in 1816 and began to study what came to be called "Personal Equation." This study of variability in the ability of astronomers to observe stars is the first significant instance of scientific study of human attributes associated with job performance.

Sir Francis Galton (1822-1911) is considered the father of engineering psychology. Galton was concerned with the problems of individual differences to the extent that, in 1884, he opened a Demonstrational Anthropometric Laboratory at the International Health Exhibition. This facility, often referred to as Galton's Tent, contained instruments for measuring a vast number of anthropometric and psychometric characteristics. Galton's instruments included a pendulum device for measuring reaction times, an apparatus for measuring the speed of a blow struck with the arm, and instruments for measuring color discrimination, visual acuity, olfactory discrimination, and other human attributes.

More recent studies of human attributes have been conducted by military research establishments such as the Army Research Institute, the Office of Naval Research, the Naval Personnel Research and Development Center, and the Air Force Human Resources Laboratory. The current literature study was facilitated by a recently completed review and critique of approaches to jobs/skills analysis and taxonomic classifications carried out by Dunlap and Associates (1979) under ARI Contract No.

DAHC19-78-C-0016. That review provided a survey of task analysis methods. Since that objective is similar to that of this project, a careful examination of their findings is recommended for more detailed information.

Another relevant study is Bownas et. al. (1978) search of the literature for previous taxonomies of performance, ability, or behavior which resulted in 920 computer-generated abstracts. Subsequent screening resulted in their careful review of about 100 articles leading to a detailed analysis of 23. A careful reading of these reviews leads to the conclusion that, of all the existing approaches, McCormick's research (1979) with the Position Analysis Questionnaire (PAQ) is most relevant.

Vineberg and Taylor (1976, 1978) expanded McCormick's work to develop parallel rating instruments, one job-oriented and one worker-oriented. In developing these scales they noted:

When a detailed analysis of job performance is to be made, either of these modes of classifying the components of the job has something to recommend it. Job-oriented descriptions refer to particular tasks, equipment, or products of performance. They generally provide an easily understood and unambiguous statement of a directly observable and quite specific aspect of a job. Thus, there is little likelihood of misunderstanding the particular aspect of performance that is to be evaluated.

Worker-oriented descriptions, on the other hand, refer to human behaviors or other aspects of work that are less specific. Since these descriptions are general to many situations, one of their virtues is that they provide a possible basis for making inferences from one job or task to another; i.e., they may permit generalizations to be made from data about performance in particular jobs and tasks to other situations that have not been scheduled. Also, worker-oriented descriptions lend themselves more readily to the inclusion of descriptors that refer to motivational, attitudinal, and stylistic (e.g., carefulness, persistence) characteristics.

The literature confirms that most analytic procedures designed to match individual attributes to job task requirements are cumbersome, requiring a level of detail which frequently produces more information

than is usable. The 37 human abilities defined by Fleishman are described by McCormick (1979, p. 349) as "probably the best available inventory of the most important human abilities." Even so, this inventory cannot be easily used as an analytic procedure. Approximately five pages of very small type are required to define Fleishman's inventory of abilities; 69 words are required to describe a specialized ability such as #30, WRIST-FINGER SPEED.

The rating scales used by the United States Employment Service (USES) are excellent. Many instruments, such as the Worker Trait Requirements Test described by McCormick (1979, p. 223), are based on USES classifications. Unfortunately, the USES codes reported in their DOT require the user to continuously transform alphanumeric information into the rather complex definitions presented in the DOT. The USES Handbook for Analyzing Jobs contains 384 pages and weighs one and one-half pounds. Neither it nor the DOT can be applied by an untrained user. Further, the USES no longer provides worker trait information.

The primary goal of this project is to develop a simple and fast method of obtaining preliminary information regarding personnel requirements. No analysis based on the Fleishman list or the DOT method meets this goal. The DOT descriptions of human attributes are often so complex and technical as to be difficult to comprehend, much less remember. The difficulty/complexity dimensions described earlier provide a starting point for development of simple understandable scales.

Two lists of job factors presented by McCormick (1979, pp. 316-317) are those used by Bengé, Burk, and Hay; and, the National Electrical Manufacturers Association (NEMA). These job factors have been classified by the authors in terms of complexity/difficulty as follows:

Bengé, et. al.

1. Mental requirements Complexity
2. Skill requirements Complexity
3. Physical requirements Difficulty
4. Responsibility Difficulty
5. Working conditions Difficulty

NEMA

Skill

1. Education Complexity
2. Experience Complexity
3. Initiative and ingenuity Complexity

Effort

4. Physical demand Difficulty
5. Mental or visual demand Difficulty

Responsibility

6. Equipment or process Difficulty
7. Material or product Difficulty
8. Safety of others Difficulty
9. Work of others Difficulty

Job Conditions

10. Working conditions Difficulty
11. Unavoidable hazards Difficulty

The complexity component can reasonably be maintained as a single general cognitive factor encompassing general learning ability and length of training required. The difficulty component does not seem to be a single factor, but can be described by different job aspects. Physical requirements, as in item #3 in the Benge et. al. list, are an obvious dimension of difficulty. It is also apparent that jobs can be difficult in other ways. The NEMA list links mental and visual demands to form a single "effort" factor, but these two attributes do not seem to belong together. Study of this domain suggests that difficulty has the following dimensions:

1. Physical Difficulty - Physical strength and/or stamina required;
2. Psychological Difficulty - Amount of stress and/or responsibility;
3. Sensory Difficulty - Sensory effort required.

These items plus the complexity factor provide four scales describing personnel exemplars which are sufficient to measure the complexity/difficulty dimensions.

This review of literature has suggested a wealth of information pertaining to job characteristics and human attributes. These range from the instruments developed for Galton's Tent through Ernest McCormick's job analysis methods to Military Standard 1472-B, Human Engineering Criteria for Military Systems, Equipment and Facilities. The problem is summarized

by Dreyfuss (1967) who states, "The problem was that we had no single body of knowledge we could turn to for all the facts we might need." It is clear that what is needed is a summary, synthesis, and analysis of the state-of-the-art of matching job characteristics and human attributes.

C. ANALYSIS OF A NEW WEAPON SYSTEM IN THE ADVANCED STAGE OF DEVELOPMENT

1. History of Infantry Fighting Vehicle (XM-2) Development

The sixteen-year history of development of the Infantry Fighting Vehicle (IFV) can be characterized as one of continuing change and increasing complexity. The IFV began in 1963 as MICV-65 (Mechanized Infantry Combat Vehicle). The broad mission of MICV-65 and all subsequent vehicles was to provide the cavalry with close proximity infantry support. In 1966, development of MICV-65 was halted as a result of design problems.

In 1972, a new contract was let and the FMC Corporation began development of MICV-XM723. The MICV went through several stages of concept development and went into Operational Test-I. As a result of human factor problems encountered during testing, an evaluation of the system was undertaken in 1976. The findings showed that most of the problems were caused by the design of the one-man turret. The task force recommended the design of a two-man (gunner/commander) turret. Concept development of the MICV-TBAT II (Mechanized Infantry Combat Vehicle - TOW Bushmaster Anti-Tank two-man turret) began in October of 1976. Shortly after the formal mock-up review, the Army established the fighting vehicle system consisting of the Infantry Fighting Vehicle (IFV), Cavalry Fighting Vehicle (CFV) and the General Support Rocket System (GSRS). MICV-TBAT II became the Infantry Fighting Vehicle. The IFV will go into operational testing early in 1980.

2. Personnel Requirements Issues

Historically, the IFV prime contractor has been only marginally involved in the development of tactics, logistics, and doctrine. For example, IFV design requirements reduced the squad from eleven to nine. Yet, as recently as October 1978, the FMC Corporation was asked to conduct ten- and eleven-man squad studies. Recent decisions on the tactics and logistics of the IFV have reduced the IFV platoon from four vehicles to three and increased the number of resupply trucks required to support

the platoon. The sixteen-year history of the development of the IFV provides a case study of the problems of determining personnel requirements for new and advanced systems.

An extensive report pertaining to performance requirements was developed by Dunlap and Associates (1979). This documented the problems encountered when traditional testing methods are used in an attempt to determine performance requirements. The Dunlap report shows the difficulty of attempting to describe specific performance requirements by using batteries of standardized (and some not so standardized) instruments which were not designed for the purpose. It appears that what is needed is a systematic procedure for identifying job requirements associated with the IFV.

The problem of identifying relevant human attributes is further documented by Bownas et. al. (1978) who reviewed 920 abstracts in an effort to identify skills and abilities pertaining to Army jobs. They identified only one paper which "suggested potentially relevant behavior elements and applicable procedures" (p. 6). For these reasons, designers of new weapon systems like the IFV and the military sponsors who must monitor the development process have no effective way of matching system requirements to human capabilities.

For example, one of the requirements of IFV personnel is to maintain a "silent watch" in which the personnel must be alert but inactive for long periods of time. Dreyfuss (1967, p. 18) has the following to say concerning watch keeping: "Long watch periods are harmful, and a vigilance decrement may set in where signals may be missed. To minimize the vigilance decrement, consider the following recommendation" Dreyfuss then lists seventeen steps which should be taken. These steps pertain to the "psychological difficulty" personnel exemplar and would relate to the amount of stress associated with this particular task. This level of analysis is not possible when the job analyst must consider the total range of all possible requirements. A branching job analysis program, however, would allow the analyst to consider such specific details, when required and only when required.

The IFV was used as a prototypical new weapon system during this project. Study of IFV requirements will be continued and intensified in future efforts to evaluate the methodology used in specifying the personnel requirements of an existing weapon system.

II. METHODS

A. PURPOSE AND SCOPE

Cronbach (in Dunnette, 1976, p. 474) distinguishes between maximum performance and typical behavior. But neither what persons can do when they perform at their highest level nor what they usually do is of much use in developing performance requirements. The key issue is the minimum acceptable level of performance required to adequately perform a task or job. The term "adequate performance" will be used to describe performance which is sufficient to successfully perform a job, task, or duty.

The current effort identified a significant body of theoretical and applied research literature. This information will be organized and expanded to produce a hierarchical organization of human attributes to be used in constructing personnel requirements scales. The results will be a synthesis of the best work of the many unrelated efforts of Army, Navy, Air Force, and civilian job analysts, giving a method based on today's technology. Once developed, the scales will provide a method to allow system designers to quickly evaluate system characteristics and determine the need for modifications at every milestone or checkpoint.

The following brief descriptions of personnel exemplars resulted from an expansion of the complexity/difficulty dimensions.

Personnel Exemplars

1. Cognitive Demands (Complexity)
Indicates the amount of learning ability and/or length of training required for successful performance.
2. Physical Demands (Difficulty)
Indicates the amount of physical strength and/or stamina required for successful performance.
3. Sensory Demands (Difficulty)
Indicates degree of perceptual acuity (typically visual and auditory) required for successful performance.
4. Psychological Demands (Difficulty)
Indicates the level of stress and/or responsibility required for successful performance.

These personnel exemplars are similar to those cited by Paul Verdier (1960). Verdier's factors of perception, judgment, internal stress, and motor ability have been used repeatedly by human factors engineers for many years.

One result of the first year's effort is a set of scales which allow raters to produce an overall estimate of job difficulty for four dimensions. Informal try-out of the forms shows that there is fair agreement between pairs of raters attempting to classify job types. For example, it is obvious to raters that psychological demands (or stress/responsibility) are quite different for a cook and a pilot. This activity has resulted in an instrument which can serve as a starting point for scale development. The Personnel Exemplars Scales developed during this project are presented in Appendix A. The four personnel exemplars can be used to summarize proposed performance requirements subscales and, independently, as gross measures of relative difficulty and complexity.

A discussion of some of the issues pertaining to these four exemplars follows:

Physical Demands

The Army Research Institute has, under separate contract, explored the physical dimensions of job requirements. This research will be reviewed and incorporated in performance requirements scales associated with the physical demands personnel exemplar. This effort, "Physical Performance Standards for Army Jobs" was recently completed under contract MDA-903-79-C-0093.

Perceptual Demands

Most job analyses refer only to the perceptual demands of hearing and vision but other equally important perceptual demands exist. For example, the driver of a butane truck or a plumber installing gas lines should have a highly developed sense of smell so that they are aware of escaping gases. The same is true for military personnel in certain selected MOSs or situations.

Cognitive Demands

This is a fruitful area because it includes training, testing, education, and a host of other mental factors which have long been the subject of exploration. The problem in this area will be, not identifying relevant performance requirements, but limiting those available to a reasonable number.

Psychological Demands

Most job analyses deal with cognitive demands; some with physical demands and few deal with perceptual demands. Little consideration is given to the psychological dimension which is frequently critical, particularly in a military environment. For example, the "silent watch" requirement of IFV personnel states that they must be in

a combat-ready stance for several hours. For some individuals, this requirement would be excruciating but other individuals might find it suited to their personality. In a study of Navy personnel requirements, Dunnette (1976) identified certain factors which should be considered in a search for psychological exemplars. Among those listed were handling stressful and emergency situations, integrity, responsibility, and motivating unit and subordinate personnel.

The current effort has resulted in a conceptual design for a decision logic that will provide measures of personnel requirements. The Year 2 effort will result in a branching instrument which provides the required level of detail for factors which are relevant to a specific system. Figure 2 provides a preliminary model for a portion of the branching network associated with the perceptual demands personnel exemplars. An instrument based on this model could lead to detailed analysis of relevant vision factors. This branching approach provides detailed information when needed without requiring detailed analysis of nonrelevant factors.

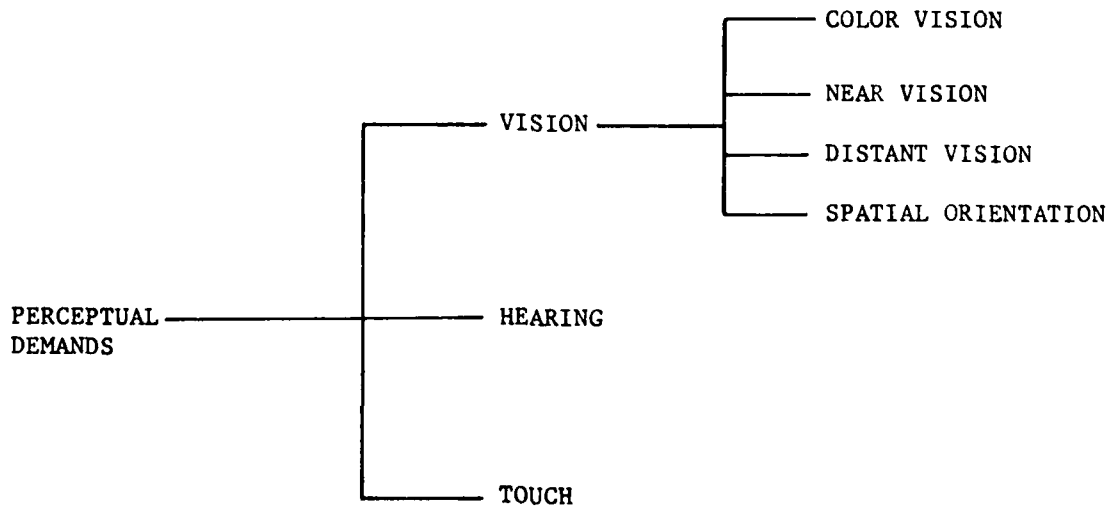

Figure 2. PERSONNEL EXEMPLAR BRANCHING NETWORK

As another example, if "physical stamina" is identified as an important consideration, a branching series of scales could be used to identify the specific relevant aspects of the physical demands exemplar. Highly specific descriptors such as the following definition in the Fleishman scale (in McCormick, 1979, p. 353) would then be useful.

WRIST-FINGER SPEED. This ability is concerned with the speed with which discrete movements of the fingers, hands, and wrists can be made. The ability is not concerned with the speed of initiation of the movement. It is only concerned with the speed with which the movement is carried out. This ability does not consider the question of the accuracy of the movement; nor does it depend upon precise eye-hand coordination.

If cognitive complexity is an important factor, elements of the Task Rating Scales (Gilbert, Waldkoetter, & Raney, 1978) would be considered. The Task Rating Scales measure type of training, task learning difficulty, consequences of inadequate performance, and task delay tolerance. Additional study of these elements would be useful in personnel prediction.

These scales shown in Appendix A were created during the current project year and provide a foundation for future subscales development. Four efforts are recommended:

1. Synthesize information concerning performance requirements from existing literature in order to determine human attributes which should be identified;
2. Develop a computer-assisted branching scales system using the human attributes identified;
3. Field-test the computer-assisted job analysis program using a variety of job descriptions;
4. Expose potential users to the system and obtain information pertaining to its usefulness.

The proposed approach employs computer technology for two reasons. First, it allows the user to interact with a vast amount of information in a rapid and efficient manner. The branching network makes the bulk of the information transparent to the user. Second, the computer will record and analyze the user's transactions which will allow evaluation of the system.

B. IMPLEMENTATION

1. Develop Computer-Assisted Job Analysis Programs

During the current effort, a preliminary and limited prototype of a computer-assisted job analysis program has been created. Using microcomputer technology, a branching program has been written which summarizes human attributes (aptitudes in their broadest sense) into the four factors of cognitive demands, physical demands, sensory demands, and psychological demands. Physical demands, for example, simply pertain to the question, "How hard is it to do this job?" Since a reasonable response to this question is the second question, "What is meant by difficult?", the proposed personnel requirements subscales will provide detailed information concerning specific physical demands. If the various physical performance requirements are summed, the most physically demanding job is identified as the one that contains the most difficult performance requirements. This approach has great promise since a large amount of detail will be required for certain performance requirements and little, if any, for others. The proposed approach provides the dual benefit of both gross summaries and very precise measures.

Appendix B presents sample output documents as a preliminary demonstration of the feasibility of an interactive and branching job analysis program. This prototypical program is in a very early stage of development; these first efforts are offered to demonstrate its potential.

After the branching scales have been constructed, the program will be made available to a sample of potential users so that they can apply this methodology to existing problems. For example, the designer of a new system might be asked to use the branching scales to analyze the performance requirements of the proposed weapon. As another example, an organization interested in analyzing current or future manning requirements could be given an opportunity to determine whether the scales provide useful data. It is expected that at least one field-test site will be a military school which will evaluate the usefulness of the branching scales as a method of specifying training needs. These potential users, or others, will provide information for user acceptance studies so that the theoretical utility of the methodology is confirmed by its usefulness in operational environments.

2. Investigate Methods of Describing Jobs

Studies of the effect of editorial difficulty (see Appendix C) and use of technical terminology for job descriptions have not been identified. Such

studies might yet be encountered in the continuing review of the literature, although their direct relevance to the specific issues under consideration is likely to be limited. The proposed research effort will provide data which are directly relevant.

Information requirements may be defined as an n-dimension variable relating to the language used to describe personnel requirements associated with the tactical missions and operational environments of a weapon system. The decisions made by any rater are strongly affected by the nature and amount of information provided. Job analysts have tended to provide and have attempted to obtain more and more information in greater and greater detail. A goal of this project is to determine whether it is appropriate to reverse this trend. As Herbert Spencer stated, "When a man's knowledge is not in order, the more he has of it the greater will be his confusion."

An essential first task is to determine the most effective way of providing information to be used by job analysts. The research procedure proposed will allow simultaneous study of the effect of the kind of information provided raters and the usefulness of the computer-based job analysis program.

The current effort has resulted in the creation of nine different kinds of job descriptions for each of twelve jobs. The jobs range from familiar jobs, such as light truck driver, through unfamiliar jobs such as HAWK gunner to prototypical military jobs such as IFV gunner and includes job descriptions which are still in the conceptual design stage. The following jobs are described in Appendix C:

Common and Familiar Jobs

1. Light Truck Driver
2. Auto Mechanic
3. Military Police

Existing but Unfamiliar Jobs

4. Computer Operator
5. Missile Facilities Repairer
6. HAWK Gunner *
7. Deep Submergence Vehicle Operator

Prototypical Jobs in Advanced Stage of Development

8. IFV Gunner *
9. IFV Commander
10. IFV Driver

Concept Design Stage of Future Jobs

11. Orbital Earth Station Ecology Technician *
12. Mechanized Commando *

* Descriptions include illustrations

Each of the twelve jobs are described by the following nine types of job descriptions:

1. Short description of general tasks.
2. Short description of specific job tasks.
3. Detailed description of general job tasks.
4. Detailed description of specific job tasks.
5. Worker-oriented description in narrative form.
6. Worker-oriented description in tabular form.
7. Short description of specific job tasks (#2) with an illustration.
8. Detailed description of specific job tasks (#4) with an illustration.
9. Worker-oriented description in narrative form (#5) with an illustration.

Finding the most appropriate way of describing jobs is essential in order for the Personnel Requirements Branching Scales to be used effectively.

3. Field-Test the Job Analysis Programs

The prototypical computer-assisted job analysis system will be tested with the range of job descriptions that have been developed. This field-test will simultaneously determine the best way of presenting job descriptions and the most appropriate way of analyzing the performance requirements of these jobs. The field-test requires that the jobs be reviewed by raters. A rater is the individual who uses the computer program to analyze jobs. The study will determine inter-rater agreement and reliability of the ratings.

The subjects for this field-test will determine the extent to which the Personnel Requirements Branching Scales allow military personnel to identify requirements of a specific job or MOS duty when varying amounts and kinds of information are provided. Military job analysts, trainers, and others who need information regarding performance requirements will be selected for this study. The design will allow determination of the effect of varying rater knowledge of jobs on their ratings. The effect of various ways of describing jobs will also be studied so that the most effective way of presenting information can then be used.

The 108 job descriptions in Appendix C will be used to field-test the Personnel Requirements Branching Scales. The data will provide answers for the following questions.

1. How much information do raters need in order to reliably identify personnel requirements? How does complexity of job descriptions affect inter-rater reliability?
2. How do various levels of editorial difficulty affect inter-rater reliability?
3. How does the way in which jobs are described affect the values assigned by raters to specific performance requirements?
4. Can a "best way" of describing jobs be identified?

TABLE 1
SAMPLING DESIGN

Showing Jobs (1 to 12), Raters (A to R), and Types of Job Descriptions (I to IX)

	RATERS A TO R (N=18)																		
	A	B	C	D	E	F	G	H	I	J	K	L	M	N	O	P	Q	R	
I	1								12	11	10	9	8	7	6	5	4	3	2
II	2	1							12	11	10	9	8	7	6	5	4	3	
III	3	2	1						12	11	10	9	8	7	6	5	4		
IV	4	3	2	1					12	11	10	9	8	7	6	5			
V	5	4	3	2	1				12	11	10	9	8	7	6				
VI	6	5	4	3	2	1				12	11	10	9	8	7				
VII	7	6	5	4	3	2	1				12	11	10	9	8				
VIII	8	7	6	5	4	3	2	1				12	11	10	9				
IX	9	8	7	6	5	4	3	2	1				12	11	10				
I	10	9	8	7	6	5	4	3	2	1						12	11		
II	11	10	9	8	7	6	5	4	3	2	1							12	
III	12	11	10	9	8	7	6	5	4	3	2	1							
IV		12	11	10	9	8	7	6	5	4	3	2	1						
V			12	11	10	9	8	7	6	5	4	3	2	1					
VI				12	11	10	9	8	7	6	5	4	3	2	1				
VII					12	11	10	9	8	7	6	5	4	3	2	1			
VIII						12	11	10	9	8	7	6	5	4	3	2	1		
IX							12	11	10	9	8	7	6	5	4	3	2	1	

Table 1 shows the sampling design required to obtain one rating based on each type of job description without presenting any specific job to a

rater more than once. In order to obtain a minimum sample ($n=10$), 108 raters would be required to provide twelve ratings for each specific type of job description. That is, Table 1 must be replicated six times to obtain a sample of 12 raters for each cell of the matrix. As shown in the table, each of the 18 raters rate all 12 jobs described in different ways. This yields two ratings for each job described according to the nine kinds of job descriptions. To obtain a sample of 12 raters per cell, 108 raters are required.

Raters will use the interactive computer program to analyze 12 job descriptions. To control for sampling bias due to order of presentation, the job number and descriptions will be randomly arranged as shown below in Table 2. This will ensure that the information provided raters is varied according to the length, difficulty, and complexity of descriptions. For example, the descriptions for the K-Column raters will be presented in the following random sequence as interpreted from Table 1.

TABLE 2

EXAMPLE OF RANDOM PRESENTATION OF JOBS AND PAIRED JOB DESCRIPTIONS

Job Number	11	4	6	12	5	8	2	9	7	3	1	10
Job Description	III	V	VII	IV	VI	IX	III	I	VIII	IV	II	II

After reading each job description, and before beginning the Personnel Requirements Branching Scales program, each subject will answer the following questions regarding the job description:

1. How familiar are you with this job?
 - (A) I have done it.
 - (B) I know quite a bit about it.
 - (C) I have some information about it.
 - (D) I knew nothing about it before reading the job description.

2. How understandable is this job description?
 - (A) It clearly described this job.
 - (B) It gives me a rough idea of what this job is all about.
 - (C) After reading it, I am not sure what this job is all about.

A study by Christal (1960) found that the length of job descriptions was an important consideration in that full-length job descriptions tended to produce higher ratings than shorter descriptions. However, the rank order of jobs in the wage structure was not affected. This is important because a long-range goal of the current effort is to produce a rank-order listing of jobs of interest.

The results of the proposed research will be a simple, efficient, and valid method of analyzing performance requirements associated with various jobs. Further efforts will be directed at developing profiles for MOS's using the standardized scales of the Personnel Requirements Branching Scales.

III. SUMMARY OF PROPOSED RESEARCH AND DEVELOPMENT

A. PLAN SUMMARY FOR YEAR 2

This year's research effort can be viewed as Phase 1 of a continuing study. The result of Phase 1 has been the development of this research plan, with prototypical decision branching logic and personnel exemplars.

Phase 2: *Develop Personnel Requirements System*

TECHNICAL OBJECTIVE. The purpose is to extract, organize and synthesize information from a vast corpus of studies pertaining to job requirements and human traits to identify personnel attributes for each item on the proposed scales. The scales will provide firm benchmarks or anchor points for measuring and comparing jobs along the four dimensions. During scale development, a computer-assisted job analysis methodology will be created. Finally, the computer-assisted analysis system will be pilot-tested using a variety of jobs and a variety of ways of describing these jobs.

SCOPE OF WORK. To accomplish the technical objective specified, the research effort is organized into four tasks, which are described below. The contractor will provide the necessary qualified personnel, facilities, materials, and services to accomplish these tasks. These four tasks will be completed during the second contract year.

Task 1. Develop Personnel Requirements Scales

This task requires the analysis of various approaches to documentation of human attributes and the selection of those which are relevant. Subscales will be created for each of the four personnel exemplars of psychological, physiological, cognitive, and perceptual difficulty.

Task 2. Create a Branching Scales Program

Once the relative and relevant performance requirements have been identified, they will be integrated into a branching personnel requirements analysis computer program.

Task 3. Pilot-Test the Branching Scales Program

Pilot tests will be run on the program at benchmark points in program development.

Task 4. Pilot-Test the System

Once the computer program is functioning, job descriptions of the type presented in Appendix C will be used to pilot-test and refine the system. This step will identify the most effective ways of describing jobs for use with this system and will provide an opportunity for hands-on experience with the computer program in a job analytic setting.

ESTIMATED TIMELINE FOR YEAR 2. Task 1 will take approximately 6 months; Task 2 and 3, 3 months; and, Task 4, an additional 3 months. The proposed timeline, then, is 12 months from contract approval to the delivery of a functioning computer-assisted job analytic program.

B. PLAN SUMMARY FOR YEARS 3-5

The long-range goal is to develop profiles for military jobs using the standardized scales of the Personnel Requirements Branching Scales. These profiles can describe the performance requirements and the nature of the incumbents of specific MOS's.

When a Performance Requirements Branching Scales system is created, it will be used to evaluate various applications of the methodology to determine the most effective uses of the information obtained. Longer-range forecasts of implementation schedules must, of necessity, be made after a decision is made concerning the most appropriate use of the methodology. The following phases 3 through 7 will be modified as a result of the findings of the Year 2 effort, the specific nature of the operational version of the Personnel Requirements Branching Scales, and the needs of the Army.

Phase 3: User Acceptance Studies

While job description studies are being carried out, selected contractors, trainers, and others interested in studying the personnel requirements of military systems would be given an opportunity to use the system and evaluate its relevance to their needs. The IFV prime contractor and the military project manager will be invited to participate in these studies.

Phase 4: Develop Soldiers and Team Profiles

Level of test performance (ASVAB and others) is a matter of record but other capabilities are either unknown or the information is not readily available. Further, many individual abilities change over time with the result that performance capability information becomes obsolete. Not only will the proposed system identify performance requirements for the individuals but can be used to provide information concerning the set of skills required in an operational team. The proposed system could be used to provide such data to unit commanders.

Phase 5: Develop Performance Requirements Profiles

As shown previously, the performance requirements of various jobs are at best imperfectly understood. Availability of an easy way to describe these requirements should greatly enhance selection procedures. Comparing individual capabilities to the performance requirements of schools and duty assignments would improve the likelihood of correct placement. To a degree, selection profiles are currently used but are based primarily on the results of paper and pencil tests. The TRASANA model implies a much broader definition of soldier characteristics.

Phase 6: Develop Group Profiles

Individual group data can be aggregated to create profiles for many kinds of groups ranging from task teams (squads) to worker types (MOS) to an overall description of the characteristics of the Army. The last is an ambitious concept but might be indicated at some future time. Clearly, this type of information is essential in order to match the performance requirements of a new weapon system to the characteristics of individuals in the MOS for which the system is intended.

Phase 7: Develop Baseline Population Data

Using conventional instrument standardization procedures, it would be relatively simple to obtain normative data concerning the extent to which required skills are present in the Army, in the civilian labor pool, or both. These data would allow planners to model the effect of new and existing system requirements. Perhaps the greatest potential use of the methodology is to improve understanding of the ways in which current and future performance requirements of weapon systems relate to the characteristics of the labor pool. Simply stated, what are the performance characteristics of the persons that we have and what do we need?

REFERENCES

- Boring, E.G. *A History of Experimental Psychology*. New York: Appleton-Century-Crofts, Inc., 1957.
- Bownas, D.A. and Cooper, M.A. *Review of Reported Behavior and Performance Taxonomies*. Personnel Decisions Research Institute, Minneapolis, Minn., 1978.
- Christal, R.E. and Madden, J.M. *Effects of Degree of Familiarity in Job Evaluation*. USAF Personnel Laboratory, Lackland AFB, Texas: Wright WADD-TN-60-257, October 1960, 1-8 in Nash, A.N. and Carroll, S.J. *Management of Compensation*. Monterey, California: Brooks Cole, 1975.
- Dreyfuss, H. *The Measure of Man: Human Factors in Design*. New York: Whitney Publications, Inc., 1967.
- Dunlap and Associates, Inc. *Survey of Task Analysis Methods, Data Item 002AC: Contract No. DAHC 19-78-C-0016, Alexandria, Virginia: U.S. Army Research Institute for the Behavioral and Social Sciences, 1979.*
- Dunlap and Associates, Inc. *IFV/CFV Personnel Section Analysis, Final Report: Contract No. DAHC 19-78-C-0016, Alexandria, Virginia: U.S. Army Research Institute for the Behavioral and Social Sciences, 1979.*
- Dunnette, M.D., ed. *Handbook of Industrial and Organizational Psychology*. Chicago: Rand McNally College Publishing Company, 1976.
- Gilbert, A.C., Waldkoetter, R.O., and Raney, J.L. ARI Technical Paper 343: *Efficacy of a Training Priorities Model in an Army Environment*. Alexandria, Virginia: U.S. Army Research Institute for the Behavioral and Social Sciences, 1978.
- McCormick, E.J. *Job Analysis: Methods and Applications*. New York: American Management Association, 1979.
- Meyers, D.C., Gebhardt, D.L., and Fleishman, E.A. *Physical Performance Standards For Army Jobs, Final Report: Contract No. MDA 903-79-C-0093, Alexandria, Virginia: U.S. Army Research Institute for the Behavioral and Social Sciences, February 1980.*
- Verdier, P. *Basic Human Factors for Engineers*. New York: Exposition Press, 1960.
- Vineberg, R. and Taylor, E.N. *Performance of Men in Different Mental Categories: 1. Development of Worker-Oriented and Job-Oriented Rating Instruments in Navy Jobs, Technical Report HumRRO 76-1, October 1976.*
- Vineberg, R. and Taylor, E.N. *Performance of Men in Different Mental Categories: 2. Development of Worker-Oriented and Job-Oriented Rating Instruments in Navy Jobs, Technical Report HumRRO 78-5, 1978.*

APPENDIX A
Personnel Exemplars

PERSONNEL EXEMPLARS SCALES

0 1 2 3 4 5 6 7
I---I---I---I---I---I---I---I....

PHYSICAL DEMANDS

Required Level of Physical
Stamina and/or Strength

SCALE DESCRIPTORS

0-None
1-Very Low
2-Low
3-Low Average Strength/
Stamina
4-High Average Strength/
Stamina
5-High
6-Very High
7-Almost Superhuman

0 1 2 3 4 5 6 7
I---I---I---I---I---I---I---I....

PSYCHOLOGICAL DEMANDS

Stress Level and/or
Amount of Responsibility
Associated With the Job

SCALE DESCRIPTORS

0-None
1-Very Low
2-Low
3-\$10,000 Loss
4-\$50,000 Loss
5-High
6-Very High
7-Life-and-Death

0 1 2 3 4 5 6 7
I---I---I---I---I---I---I---I....

PERCEPTUAL DEMANDS

Required Level of
Sensory Acuity
Vision, Hearing, Etc.

SCALE DESCRIPTORS

0-None
1-Very Low
2-Low
3-Low Average Acuity
4-High Average Acuity
5-High
6-Very High
7-Almost Superhuman

0 1 2 3 4 5 6 7
I---I---I---I---I---I---I---I....

COMPLEXITY

Learning Ability
and/or Length of
Training Required by
the Job

SCALE DESCRIPTORS

0-None
1-Very Low
2-Low
3-On-The-Job-Training
4-1-6 Months School
5-High
6-Very High
7-2+ Years of School

SUBTEST APTITUDE AREAS FOR VARIOUS MENTAL TESTS

0 1 2 3 4 5 6 7
I---I---I---I---I---I---I---I....GI

General Information
Knowledge of Outdoor
Activities

SCALE POINTS

0-None
1-Very Low
2-Low
3-Low Average
4-High Average
5-High
6-Very High
7-Upper Level

0 1 2 3 4 5 6 7
I---I---I---I---I---I---I---I....NO

Numerical Operations
Performing Simple
calculations

0 1 2 3 4 5 6 7
I---I---I---I---I---I---I---I....AD

Attention to Detail
Clerical perception tasks

0 1 2 3 4 5 6 7
I---I---I---I---I---I---I---I....WK

Word Knowledge
General Vocabulary

0 1 2 3 4 5 6 7
I---I---I---I---I---I---I---I....AR

Arithmetic Reasoning
Applied problem solving

0 1 2 3 4 5 6 7
I---I---I---I---I---I---I---I....SP

Space Perception
Visualizing objects in
three dimensions

0 1 2 3 4 5 6 7
I---I---I---I---I---I---I---I....MK

Math Knowledge
Experience with Geometry,
Algebra, etc.

0 1 2 3 4 5 6 7
I---I---I---I---I---I---I---I....EI

Electronic Information
Understanding general
principles

0 1 2 3 4 5 6 7
I---I---I---I---I---I---I---I....MC

Mechanical Comprehension
Understanding how objects
operate

0 1 2 3 4 5 6 7
I---I---I---I---I---I---I---I....GS

General Science
Academic achievement
in Science

0 1 2 3 4 5 6 7
I---I---I---I---I---I---I---I....SI

Shop Information
Understanding shop procedure
and tools

0 1 2 3 4 5 6 7
I---I---I---I---I---I---I---I....AI

Automotive Information
Automotive principles and operation

0 1 2 3 4 5 6 7
I---I---I---I---I---I---I---I....LS

Literacy Scale
basic reading ability

APPENDIX B
Sample Personnel Requirements Scales
for the
Preliminary Prototypical Program

PERSONNEL EXEMPLARS BRANCHING NETWORK (PRELIMINARY AND PARTIAL SIMULATION)

MCFANN-GRAY AND ASSOCIATES

JANUARY, 1980

*****PRESS SPACE BAR TO CONTINUE*****

JOB DESCRIPTION

INFANTRY FIGHTING VEHICLE GUNNER(IFV GUNNER).FIRES IFV WEAPONS WORKING AS MEMBER OF TANK CREW. PREPARES IFV AND EQUIPMENT FOR MOVEMENT AND COMBAT.LOADS AMMUNITION INTO BREECH OF WEAPON.CONFERS WITH IFV COMMANDER BY VOICE AND USING THE COMBAT VEHICLE COMMUNICATION HELMET.AIMS WEAPON USING IFV FIRE CONTROL EQUIPMENT AND FIRES WEAPON AT TARGET.CAMOUFLAGES POSITION AND PROTECTS IFV AND EQUIPMENT AGAINST CHEMICAL WARFARE AGENTS.

DECONTAMINATES IFV AND EQUIPMENT WHEN EXPOSED TO CONTAMINANTS. PERFORMS PREVENTATIVE MAINTENANCE AND DIAGNOSES AND REPAIRS MALFUNCTIONS ASSOCIATED WITH THE 25MM GUN.

MAINTAINS ADEQUATE SURVEILLANCE OF EXTERNAL ENVIRONMENT WITH AID OF INTEGRATED DAY/NIGHT SIGHT(IR DISPLAY) DURING PERIODS OF LOW EXTERNAL VISIBILITY.

PHYSICAL DEMANDS

IS THIS A SEDENTARY JOB REQUIRING LITTLE PHYSICAL EFFORT?Y/N

IS STRENGTH REQUIRED TO LIFT, CARRY, PUSH, PULL, WALK, RUN, CLIMB, OR BALANCE?Y/
PHYSICAL DEMANDS

HOW MUCH WEIGHT MUST BE LIFTED?

- (A)10 LBS OR LESS
- (B)50 LBS
- (C)100 LBS
- (D)OVER 100 LBS

PHYSICAL DEMANDS

HOW MUCH WEIGHT MUST BE CARRIED?

- (A)10 LBS OR LESS
- (B)25 LBS
- (C)50 LBS
- (D)100 LBS

(E)OVER 100 LBS

HOW FAR MUST THAT WEIGHT BE CARRIED?

- (F)UP TO 100 YDS
- (G)UP TO A MILE
- (H)UP TO 5 MILES
- (I)UP TO 10 MILES
- (J)UP TO 20 MILES
- (K)OVER 20 MILES

PHYSICAL DEMANDS

WHAT DISTANCE MUST BE WALKED OR HIKED?

- (A)1 MILE OR LESS
- (B)UP TO 5 MILES
- (C)UP TO 10 MILES
- (D)UP TO 20 MILES
- (E)OVER 20 MILES(FORCED MARCH)

WOULD YOU LIKE TO RE-READ THE JOB DESCRIPTION? Y/N

PHYSICAL DEMANDS

THE FOLLOWING SCALES ARE TO BE DEVELOPED

RUNNING

PUSHING OR PULLING

CLIMBING

BALANCING

PRESS SPACE BAR TO CONTINUE

PHYSICAL DEMANDS
OTHER PHYSICAL ACTIVITIES SCALES TO BE DEVELOPED

STOOPING, KNEELING, CROUCHING AND/OR CRAWLING

GRASPING, SQUEEZING, AND/OR HOLDING

THROWING, CATCHING

HAND AND FINGER DEXTERITY

DISPLACEMENT

EYE-HAND AND/OR FOOT COORDINATION

AND OTHERS TO BE IDENTIFIED

PERCEPTUAL DEMANDS

IS COMMUNICATING (TALKING/HEARING) REQUIRED ?Y/Y

UNDER WHAT CONDITIONS IS HEARING REQUIRED?

(A) IN QUIET OFFICES? Y/

(B) IN NOISY OFFICES (TYPING POOLS)? Y/

(C) IN ENVIRONMENTS WITH HIGH FREQUENCY NOISE (JET ENGINES)? Y/

(D) IN ENVIRONMENTS WITH IMPULSIVE NOISE (EXPLOSIONS)? Y/Y

(E) IN ENVIRONMENTS WITH LOUD BROAD-BAND NOISE (HEAVY MACHINERY)? Y/Y

(F) IN ENVIRONMENTS WITH DISTRACTING AND COMPETING SIGNALS (MANY PEOPLE TALKING SIMULTANEOUSLY)? Y/Y

WHAT DEVICES MAY BE WORN THAT PROTECTS, ASSISTS, OR AFFECTS HEARING?

(A) COMBAT VEHICLE COMMUNICATION HELMET, PILOT'S HELMET, AND SIMILAR Y/Y

(B) EARPLUGS AND/OR OTOCUPS Y/

(C) HARD HATS, HELMETS AND SIMILAR Y/

(D) PROTECTIVE HOODS FOR FIRE OR RADIATION PROTECTION OR SIMILAR Y/

WHAT MUST BE HEARD?

- (A)NORMAL CONVERSATION Y/
- (B)BELLS, BUZZERS, WHISTLES, AND OTHER ALARMS Y/N
- (C)BARELY AUDIBLE SOUNDS(LISTENING FOR APPROACHING ENEMY, ESCAPING GAS, ETC.) Y/
- (D)IMPORTANT SOUNDS MIXED WITH DISTRACTING NOISES(COMMAND DURING A FIRE FIGHT) Y

WHAT TYPE OF SPEAKING IS REQUIRED?

- (A)NORMAL 2 PERSON COMMUNICATION Y/
- (B)FORMAL SPEAKING TO GROUPS(SPEECHES, BRIEFINGS, ETC.) Y/
- (C)YELLING, SHOUTING, AND COMMUNICATING TO DISTANT PERSONS Y/
- (D)DELIVERING COMPLICATED OR CODED MESSAGES(AIR TRAFFIC CONTROLLERS, PILOTS, ETC)

Y/
PERCEPTUAL DEMANDS

WHAT ARE THE VISION REQUIREMENTS? (A)FAR VISION REQUIRED-SEE CLEARLY AT DISTANCES OF 20 FT OR MORE(TARGET IDENTIFICATION)

(B)NEAR VISION REQUIRED-SEE CLEARLY AT DISTANCES OF 20 INCHES OR LESS(READING AND SIMILAR)

(C)DEPTH PERCEPTION REQUIRED-VISUALLY JUDGE DISTANCE AND SPACE RELATIONSHIPS IN 3-DIMENSIONS(MUST HAVE FUNCTION OF BOTH EYES)

MAY THESE VISION REQUIREMENTS BE BASED ON CORRECTED VISION?

- (A)YES, CORRECTED VISION IS OK
 - (B)NO GLASSES OR AIDS
- PERCEPTUAL DEMANDS

IS COLOR VISION REQUIRED(ABILITY TO IDENTIFY AND DISTINGUISH COLORS)Y/N
PERCEPTUAL DEMANDS

IS SMELLING(ODOR IDENTIFICATION)REQUIRED?Y/

COGNITIVE DEMANDS
TYPE OF TRAINING

- (A)NO TRAINING REQUIRED
- (B)ON-THE-JOB TRAINING
- (C)FORMAL UNIT TRAINING
- (D)NONRESIDENT SCHOOL TRAINING
- (E)RESIDENT SCHOOL TRAINING

TASK LEARNING DIFFICULTY

- (A)EXTREMELY LOW(NO TRAINING REQUIRED)
- (B)LOW
- (C)SOMEWHAT BELOW AVERAGE
- (D)AVERAGE

***PRESS RETURN KEY FOR FURTHER CHOICE

- (E)SOMEWHAT ABOVE AVERAGE
- (F)HIGH
- (G)EXTREMELY HIGH(TRAINING IS ESSENTIAL)

CONSEQUENCES OF INADEQUATE PERFORMANCE

- (A)EXTREMELY LOW
- (B)LOW
- (C)SOMEWHAT BELOW AVERAGE
- (D)AVERAGE
- (E)SOMEWHAT ABOVE AVERAGE
- (F)HIGH
- (G)EXTREMELY HIGH

SUMMARY

PHYSICAL DEMANDS

THIS JOB REQUIRES

PHYSICAL EFFORT:

10 LBS MUST BE LIFTED;
10 LBS OR LESS
MUST BE CARRIED

PERCEPTUAL DEMANDS

THIS JOB REQUIRES

COMMUNICATION

IN ENVIRONMENTS WITH IMPULSIVE NOISE
IN ENVIRONMENTS WITH LOUD BROAD-BAND NOISE
IN ENVIRONMENTS WITH DISTRACTING AND COMPETING SIGNALS
COMBAT VEHICLE COMMUNICATION HELMET, ETC. WILL BE WORN
BARELY AUDIBLE NOISES MUST BE HEARD
IMPORTANT SOUNDS MIXED WITH DISTRACTING NOISES MUST BE HEARD

SPEAKING REQUIREMENTS:
NORMAL 2 PERSON COMMUNICATION

VISUAL REQUIREMENTS:

FAR VISION REQUIRED
NEAR VISION REQUIRED
DEPTH PERCEPTION REQUIRED
BASED ON CORRECTED VISION
ODOR IDENTIFICATION IS REQUIRED

TYPE OF TRAINING:
FORMAL UNIT TRAINING

TASK LEARNING DIFFICULTY:
AVERAGE

CONSEQUENCES OF INADEQUATE PERFORMANCE:

HIGH

PERSONNEL EXEMPLARS BRANCHING NETWORK (PRELIMINARY AND PARTIAL SIMULATION)

MCFANN-GRAY AND ASSOCIATES

JANUARY, 1980

*****PRESS SPACE BAR TO CONTINUE*****

JOB DESCRIPTION

HAWK GUNNER. OPERATES AND FIRES HAWK MISSILE WEAPON SYSTEM (SHORT RANGE GROUND TO AIR MISSILE) TO DESTROY LOW FLYING ENEMY AIRCRAFT: OBSERVES LOW FLYING ENEMY AIRCRAFT OR RECEIVES RADAR INFORMATION CONCERNING ENEMY AIRCRAFT.

VISUALLY IDENTIFIES AIRCRAFT DETECTED. EVALUATES ENEMY THREAT, AND ESTABLISHES PRIORITY OF ENGAGEMENT. NOTIFIES SUPERIOR OF TARGET. PRESSES SWITCHES, UPON ORDER, TO ACTIVATE AUTOMATIC TRACKING SYSTEM AND FIRES MISSILE AT TARGET.

CONFERS WITH SUPERVISOR, USING RADIO TO TRANSMIT RESULTS OF FIRING. SELECTS APPROPRIATE PRIMARY AND ALTERNATE POSITIONS FOR HAWK EMPLOYMENT CONSIDERING CAPABILITIES AND LIMITATIONS OF WEAPON, FRIENDLY TROOP LOCATION AND SITUATION IN AREA TO BE DEFENDED, AND PROBABLE AIRCRAFT TACTICS AND DIRECTION OF ATTACK

*****PRESS SPACE BAR TO CONTINUE***

PHYSICAL DEMANDS

IS THIS A SEDENTARY JOB REQUIRING LITTLE PHYSICAL EFFORT? Y/N

IS STRENGTH REQUIRED TO LIFT, CARRY, PUSH, PULL, WALK, RUN, CLIMB, OR BALANCE? Y/

PHYSICAL DEMANDS

HOW MUCH WEIGHT MUST BE LIFTED?

(A) 10 LBS OR LESS

(B) 50 LBS

(C) 100 LBS

(D) OVER 100 LBS

PHYSICAL DEMANDS
HOW MUCH WEIGHT MUST BE CARRIED?

(A)10 LBS OR LESS

(B)25 LBS

(C)50 LBS

(D)100 LBS

(E)OVER 100 LBS

HOW FAR MUST THAT WEIGHT BE CARRIED?

(F)UP TO 100 YDS

(G)UP TO A MILE

(H)UP TO 5 MILES

(I)UP TO 10 MILES

(J)UP TO 20 MILES

(K)OVER 20 MILES

PHYSICAL DEMANDS
WHAT DISTANCE MUST BE WALKED OR HIKED?

(A)1 MILE OR LESS

(B)UP TO 5 MILES

(C)UP TO 10 MILES

(D)UP TO 20 MILES

(E)OVER 20 MILES(FORCED MARCH)

WOULD YOU LIKE TO RE-READ THE JOB DESCRIPTION? Y/N

PHYSICAL DEMANDS
THE FOLLOWING SCALES ARE TO BE DEVELOPED

RUNNING

PUSHING OR PULLING

CLIMBING

BALANCING

PRESS SPACE BAR TO CONTINUE

PHYSICAL DEMANDS
OTHER PHYSICAL ACTIVITIES SCALES TO BE DEVELOPED

STOOPING, KNEELING, CROUCHING AND/OR CRAWLING

GRASPING, SQUEEZING, AND/OR HOLDING

THROWING, CATCHING

HAND AND FINGER DEXTERITY

DISPLACEMENT

EYE-HAND AND/OR FOOT COORDINATION

AND OTHERS TO BE IDENTIFIED

PRESS SPACE BAR TO CONTINUE

WOULD YOU LIKE TO REVIEW THE JOB DESCRIPTION? Y/N
 PERCEPTUAL DEMANDS

IS COMMUNICATING(TALKING/HEARING)REQUIRED ?Y/

UNDER WHAT CONDITIONS IS HEARING REQUIRED?

(A)IN QUIET OFFICES? Y/N

(B)IN NOISY OFFICES(TYPING POOLS)? Y/N

(C)IN ENVIRONMENTS WITH HIGH FREQUENCY NOISE(JET ENGINES)? Y/N

(D)IN ENVIRONMENTS WITH IMPULSIVE NOISE(EXPLOSIONS)? Y/N

(E)IN ENVIRONMENTS WITH LOUD BROAD-BAND NOISE(HEAVY MACHINERY)? Y/N

(F)IN ENVIRONMENTS WITH DISTRACTING AND COMPETING SIGNALS(MANY PEOPLE TALKING SI
 MULTANEOUSLY)? Y

WHAT DEVICES MAY BE WORN THAT PROTECTS,ASSISTS,OR AFFECTS HEARING?

(A)COMBAT VEHICLE COMMUNICATION HELMET,PILOT'S HELMET,AND SIMILAR Y/N

(B)EARPLUGS AND/OR OTOCUPS Y/

(C)HARD HATS,HELMETS AND SIMILAR Y/

(D)PROTECTIVE HOODS FOR FIRE OR RADIATION PROTECTION OR SIMILAR Y/

WHAT MUST BE HEARD?

(A)NORMAL CONVERSATION Y/

(B)BELLS,BUZZERS,WHISTLES,AND OTHER ALARMS Y/N

(C)BARELY AUDIBLE SOUNDS(LISTENING FOR APPROACHING ENEMY,ESCAPING GAS,ETC.) Y/

(D)IMPORTANT SOUNDS MIXED WITH DISTRACTING NOISES(COMMAND DURING A FIRE FIGHT) Y

WHAT TYPE OF SPEAKING IS REQUIRED?

(A)NORMAL 2 PERSON COMMUNICATION Y/

(B)FORMAL SPEAKING TO GROUPS(SPEECHES,BRIEFINGS,ETC.) Y/

(C)YELLING,SHOUTING,AND COMMUNICATING TO DISTANT PERSONS Y/

(D)DELIVERING COMPLICATED OR CODED MESSAGES(AIR TRAFFIC CONTROLLERS,PILOTS,ETC) Y/

WHAT ARE THE VISION REQUIREMENTS? (A) FAR VISION REQUIRED-SEE CLEARLY AT DISTANCES OF 20 FT OR MORE(TARGET IDENTIFICATION AND SIMILAR)

(B) NEAR VISION REQUIRED-SEE CLEARLY AT DISTANCES OF 20 INCHES OR LESS(READING AND SIMILAR)

(C) DEPTH PERCEPTION REQUIRED-VISUALLY JUDGE DISTANCE AND SPACE RELATIONSHIPS IN 3-DIMENSIONS(MUST HAVE FUNCTION OF BOTH EYES)

MAY THESE VISION REQUIREMENTS BE BASED ON CORRECTED VISION?

(A) YES, CORRECTED VISION IS OK PERCEPTUAL DEMANDS

(B) NO GLASSES OR AIDS

IS COLOR VISION REQUIRED(ABILITY TO IDENTIFY AND DISTINGUISH COLORS)Y/

IS SMELLING(ODOR IDENTIFICATION)REQUIRED?Y/

COGNITIVE DEMANDS

TYPE OF TRAINING

(A) NO TRAINING REQUIRED

(B) ON-THE-JOB TRAINING

(C) FORMAL UNIT TRAINING

(D) NONRESIDENT SCHOOL TRAINING

(E) RESIDENT SCHOOL TRAINING

TASK LEARNING DIFFICULTY

(A) EXTREMELY LOW(NO TRAINING REQUIRED) (B) LOW

(C) SOMEWHAT BELOW AVERAGE

(D) AVERAGE

***PRESS RETURN KEY FOR FURTHER CHOICE

(E) SOMEWHAT ABOVE AVERAGE

(F) HIGH

(G) EXTREMELY HIGH(TRAINING IS ESSENTIAL)

CONSEQUENCES OF INADEQUATE PERFORMANCE

(A)EXTREMELY LOW

(B)LOW

(C)SOMEWHAT BELOW AVERAGE

(D)AVERAGE

**PRESS RETURN KEY FOR FURTHER CHOICE

(E)SOMEWHAT ABOVE AVERAGE

(F)HIGH

(G)EXTREMELY HIGH

SUMMARY

PHYSICAL DEMANDS

THIS JOB REQUIRES

PHYSICAL EFFORT:

10 LBS MUST BE LIFTED;

PRESS SPACE BAR TO CONTINUE

PERCEPTUAL DEMANDS

THIS JOB REQUIRES

COMMUNICATION

IN ENVIRONMENTS WITH DISTRACTING AND COMPETING SIGNALS

NORMAL CONVERSATION MUST BE HEARD

IMPORTANT SOUNDS MIXED WITH DISTRACTING NOISES MUST BE HEARD

PRESS SPACE BAR TO CONTINUE

SPEAKING REQUIREMENTS:

NORMAL 2 PERSON COMMUNICATION

DELIVERING COMPLICATED OR CODED MESSAGES

VISUAL REQUIREMENTS:

FAR VISION REQUIRED

NEAR VISION REQUIRED

DEPTH PERCEPTION REQUIRED

BASED ON CORRECTED VISION

PRESS SPACE BAR TO CONTINUE

COGNITIVE DEMANDS

TYPE OF TRAINING:

RESIDENT SCHOOL TRAINING

TASK LEARNING DIFFICULTY:

ABOVE AVERAGE

CONSEQUENCES OF INADEQUATE PERFORMANCE:

ABOVE AVERAGE

APPENDIX C
Job Descriptions

Introduction

This Appendix provides job descriptions developed using three methods. The first method bases job descriptions on work performed. These job-oriented descriptions can involve any and all tasks performed in a specific job; but, to provide constraints on this method, a matrix has been created. The matrix shown in Section 1 limits the number of tasks considered and the level of specificity used for each description. Therefore, for every job in Section 1, there are four descriptions which represent specific cells of the matrix they are identified by numbers 1-4 in parenthesis which identify the type of job description.

Worker-oriented descriptions have also been developed based on physical and intellectual traits that an individual needs in order to perform a specific job. These descriptions do not mention functions associated with the jobs but describe the worker's traits. Two formats for worker-oriented job descriptions are presented in Section 2. One format provides the necessary information in a narrative form and is identified by the number (5). The other presents information in a tabular format and is numbered (6). These two formats appear on pages C3 through C52.

The final method of describing jobs is to supplement the description with illustrations. Sample illustrations have been developed for four of the jobs and are presented in Section 3 on pages C53 through C56.

The nine kinds of job descriptions listed in Table 1 (presented earlier) refer to four types of job descriptions based on method one, two based on method two, and three kinds of job descriptions supplemented by illustrations.

Twelve military jobs of varying levels of familiarity have been used to illustrate the methods. The most common and familiar jobs described are light truck driver, auto mechanic, and military police. Jobs for computer operator, missile facilities repairer, HAWK gunner, and deep submergence vehicle operator represent existing but potentially unfamiliar jobs. The jobs of Infantry Fighting Vehicle (IFV) gunner, IFV commander, and IFV driver are prototypical jobs for a weapon system in an advanced state of development. The last two of the twelve jobs - the orbital earth station ecology technician and the mechanized commando - are in the conceptual design stage. They do not now, and may never, exist.

Section 1. Job-Oriented Descriptions

The matrix presented below was used as a guide in producing the job-oriented descriptions. Each cell within the matrix represents a job-oriented description in narrative form. The vertical axis controls the specificity of the narrative and the horizontal axis controls the length of the narrative.

The cells within the matrix are numbered (1) through (4). The numbers correspond to job descriptions presented in this section. All the narratives numbered (1) are based on the guidelines of cell (1) within the matrix. These narratives contain a short description of general tasks involved within a job. Cell (2) maintains the brevity of the description but provides greater specificity in the tasks than cell (1). Cell (3) provides more information concerning the job than cell (1). Therefore, cell (3) provides a detailed but general description of the job. Cell (4) provides the most comprehensive job description, giving the most detailed description of the greatest number of specific job tasks.

JOB DESCRIPTIONS BASED ON WORK PLANNED AND VARIED IN TERMS OF NUMBERS OF TASKS AND LEVELS OF SPECIFICITY

<u>Level of Specificity</u>	<u>Number of Tasks Presented</u>	
	Short description of job tasks: Approximately half of the tasks presented in the U.S. Employment Service Dictionary of Occupational Titles.	Detailed description of job tasks as presented in the U.S. Employment Service Dictionary of Occupational Titles.
Description contains general terms: Examples of work, objectives, etc. removed.	Short description of general job tasks. (1)	Detailed description of general job tasks. (3)
Description contains specific examples of work performed as presented in the Dictionary of Occupational Titles.	Short description of specific job tasks. (2)	Detailed description of specific job tasks. (4)

(1) Light Truck Driver

Drives truck to transport materials and personnel to and from specified destinations.

Applies knowledge of commercial driving regulations and roads in area.

Inspects truck equipment and supplies.

Performs emergency roadside repairs.

(2) Light Truck Driver

Drives truck with capacity under 3 tons to transport materials in liquid or packaged form and personnel to and from specified destinations, such as rail-road stations, barracks, motor pools, and supply depots.

Drives truck to destination, applying knowledge of commercial driving regulations and roads in area.

Inspects truck equipment and supplies, such as tires, lights, brakes, gas, oil, and water.

Performs emergency roadside repairs, such as changing tires, installing light bulbs, fuses, tire chains, and spark plugs.

(3) Light Truck Driver

Drives truck to transport materials and personnel to and from specified destinations.

Verifies load.

Applies knowledge of commercial driving regulations and roads in area.

Prepares receipts.

Maintains radio contact with supervisor.

Loads and unloads truck.

Inspects truck equipment and supplies.

Performs emergency roadside repairs.

(4) Light Truck Driver

Drives truck with capacity under 3 tons to transport materials in liquid or packaged form and personnel to and from specified destinations, such as railroad stations, barracks, motor pools, and supply depots.

Verifies load against shipping papers.

Drives truck to destination, applying knowledge of commercial driving regulations and roads in area.

Prepares receipts for load picked up.

Maintains radio contact with supervisor to receive delivery instructions.

Loads and unloads truck.

Inspects truck equipment and supplies, such as tires, lights, brakes, gas, oil, and water.

Performs emergency roadside repairs, such as changing tires, installing light bulbs, fuses, tire chains, and spark plugs.

(1) Mechanic

Repairs and overhauls vehicles.
Plans work procedure.
Repairs or replaces parts using mechanic's handtools.
Rebuilds parts using shop equipment.
Repairs electrical systems.
Mends damaged body and fenders.

(2) Mechanic

Repairs and overhauls jeeps, trucks, and other automotive vehicles.
Plans work procedure, using charts, technical manuals, and experience.
Repairs or replaces parts, such as pistons, rods, gears, valves, and bearings, using mechanics' handtools.
Rebuilds parts, such as crankshafts and cylinder blocks, using lathes, shapers, drill presses, and welding equipment. Rewires ignition system, lights, and instrument panel.
Mends damaged body and fenders by hammering out or filling in dents and welding broken parts.

(3) Mechanic

Repairs and overhauls vehicles.
Examines vehicle and determines extent of damage of malfunctions.
Plans work procedure.
Raises vehicle to gain access to mechanical units.
Disassembles unit and inspects parts for wear.
Repairs or replaces parts using mechanics' handtools.
Overhauls or replaces components.
Rebuilds parts using shop equipment.
Rewires electrical systems.
Relines and adjusts brakes, aligns front end, repairs or replaces shock absorbers, and solders leaks in radiator.
Mends damaged body and fenders.
Replaces and adjusts headlights, and installs and repairs accessories.

(4) Mechanic

Repairs and overhauls jeeps, trucks and other automotive vehicles.

Examines vehicle and determines extent of damage or malfunction.

Plans work procedure, using charts, technical manuals, and experience.

Raises vehicle, using hydraulic jack or hoist, to gain access to mechanical units bolted to underside of vehicle.

Disassembles unit and inspects parts for wear, using micrometers, calipers, and thickness gauges. Repairs or replaces parts such as pistons, rods, gears, valves, and bearings, using mechanics' handtools.

Overhauls or replaces carburetors, blowers, generators, distributors, starters, and pumps. Rebuilds parts, such as crankshafts and cylinder blocks, using lathes, shapers, drill presses, and welding equipment.

Rewires ignition system, lights, and instrument panel. Relines and adjusts brakes, aligns front end, repairs or replaces shock absorbers, and solders leaks in radiator.

Mends damaged body and fenders by hammering out or filling in dents and welding broken parts.

Replaces and adjusts headlights, and installs and repairs accessories, such as radios, heaters, mirrors, and windshield wipers.

(1) Military Police

Patrols assigned beat to control traffic, prevent crime and arrest violators.
Notes suspicious persons and establishments and reports to superior officer.
Renders first aid.
Investigates accidents.
Directs traffic.
Issues tickets.
Writes and files daily activity report.

(2) Military Police

Patrols assigned beat on foot or in patrol car to control traffic, prevent crime or disturbance of peace, and arrest violators.
Notes suspicious persons and establishments and reports to superior officer.
Renders first aid at accidents.
Investigates causes and results of accident.
Issues tickets to traffic violators.
Writes and files daily activity report with superior officer.

(3) Military Police

Patrols assigned beat to control traffic, prevent crime and arrest violators.
Familiarizes self with beat and with persons living in area.
Notes suspicious persons and establishments and reports to superior officer.
Reports hazards.
Disperses unruly crowds.
Renders first aid.
Investigates accidents.
Directs traffic.
Warns or arrests persons violating animal ordinances.
Issues tickets.
Writes and files daily activity report.
Notifies supervisor of location of abandoned vehicles.

(4) Military Police

Patrols assigned beat on foot or in patrol car to control traffic, prevent crime or disturbance of peace, and arrest violators.

Familiarizes self with beat and with persons living in area.

Notes suspicious persons and establishments and reports to superior officer.

Reports hazards.

Disperses unruly crowds at public gatherings.

Renders first aid at accidents.

Investigates causes and results of accident.

Directs and reroutes traffic around fire or other disruption.

Warns or arrests persons violating animal ordinances.

Issues tickets to traffic violators.

Writes and files daily activity report with superior officer.

Notifies superior officer of location of abandoned vehicles to tow away.

(1) Computer Operator

Monitors and controls electronic computer to process data.
Sets control switches on computer and peripheral equipment.
Selects and loads input and output units with materials.
Types alternate commands according to predetermined instructions.
Notifies supervisor of errors or equipment stoppage.
Wires control panels of peripheral equipment.

(2) Computer Operator

Monitors and controls electronic computer to process data, according to operating instructions.

Sets control switches on computer and peripheral equipment, such as external memory, data communicating, synchronizing, input, and output recording or display devices. Integrates and operates equipment according to program, routines, subroutines, and data requirements specified in written operating instructions. Selects and loads input and output units with materials, such as tapes or punch-cards and printout forms, for operating runs or oversees operators of peripheral equipment who perform these functions. Types alternate commands into computer console, according to predetermined instructions, to correct error or failure and resume operations. Notifies supervisor of errors or equipment stoppage. Wires control panels of peripheral equipment.

(3) Computer Operator

Monitors and controls electronic computer to process data.

Sets control switches on computer and peripheral equipment. Operates equipment.

Selects and loads input and output units with materials.

Moves switches to clear system and start operation of equipment.

Observes machines and control panel on computer console.

Types alternate commands according to predetermined instructions.

Notifies supervisor of errors or equipment stoppage. Clears unit and reviews schedule to determine next assignment.

Records operating and down time.

Wires control panels of peripheral equipment.

Controls computer to provide input or output service for another computer.

(4) Computer Operator

Monitors and controls electronic computer to process data, according to operating instructions. Sets control switches on computer and peripheral equipment, such as external memory, data communicating, synchronizing, input, and output recording or display devices. Integrates and operates equipment according to program, routines, subroutines, and data requirements specified in written operating instructions. Selects and loads input and output units with materials, such as tapes or punchcards and printout forms, for operating runs or oversees operators of peripheral equipment who perform these functions. Moves switches to clear system and start operation of equipment. Observes machines and control panel on computer console for error lights, verification printouts and error messages, and machine stoppage or faulty output. Types alternate commands into computer console, according to predetermined instructions, to correct error or failure and resume operations. Notifies supervisor of error or equipment stoppage. Clears unit at end of operating run. Reviews schedule to determine next assignment. Records operating and down time. Wires control panels of peripheral equipment. Controls computer to provide input or output service for another computer under instructions from operator of that unit.

(1) Missile Facilities Repairer

Repairs missile weapons systems support facilities and equipment.
Services support equipment.
Operates generators, battery systems, and handling equipment.

(2) Missile Facilities Repairer

Repairs missile weapons systems support facilities and equipment.
Services support equipment with fuel, lubricants, hydraulic fluid and air.
Operates auxiliary motor generators, battery systems, and portable self-powered handling equipment.

(3) Missile Facilities Repairer

Repairs missile weapons systems support facilities and equipment.
Inspects, services, and replaces components of missile weapons systems real-property, installed equipment, facilities, and ground support equipment.
Services support equipment.
Operates generators, battery systems, and handling equipment. Aligns missile to launcher.

(4) Missile Facilities Repairer

Repairs missile weapons systems support facilities and equipment.
Inspects, services, and replaces electrical, hydraulic and mechanical components of missile weapons systems real-property, installed equipment, facilities, and ground support equipment, such as missile pedestals, crib suspensions, pendulum links, shock mounts, maintenance work platforms, erection booms, umbilical brackets, and suspension devices.
Services support equipment with fuel, lubricants, hydraulic fluid and air.
Operates auxiliary motor generators, battery systems, and portable self-powered handling equipment. Aligns missile to launcher, using equipment such as collimator systems.

(1) Deep Submergence Vehicle Operator

Commands and pilots deep submergence vehicle to obtain information.

Transports passengers.

Conducts inspections of vehicle.

Pushes switches to supply power to various units.

Monitors sonar and navigational aids.

(2) Deep Submergence Vehicle Operator

Commands and pilots deep submergence vehicle (small noncombatant submarine) to obtain oceanographic research information.

Transports passengers, such as scientists, researchers, and technicians to ocean bottom.

Conducts pre-dive and post-dive inspections of vehicle to insure vehicle is seaworthy and life support systems are functioning in specified manner.

Pushes switches to supply power to various units, such as manpower supply and mechanical arms which are located outside of the vehicle and are used to pick up, collect, or move objects on ocean floor.

Monitors sonar and navigational aids.

(3) Deep Submergence Vehicle Operator

Commands and pilots deep submergence vehicle to obtain information.

Recovers sunken objects.

Transports passengers.

Conducts inspections of vehicle.

Reads gauges.

Navigates vehicle.

Steers vehicle.

Pushes switches to supply power to various units.

Monitors sonar and navigational aids.

Directs subordinates.

(4) Deep Submergence Vehicle Operator

Commands and pilots deep submergence vehicle (small noncombatant submarine) to obtain oceanographic research information. Recovers other sunken vessels or objects from ocean floor. Transports passengers, such as scientists, researchers, and technicians to ocean bottom. Conducts pre-dive and post-dive inspections of vehicle to insure vehicle is seaworthy and life support systems are functioning in specified manner. Reads gauges to verify hydraulic fluid, air pressure, and oxygen are at designated levels. Navigates vehicle based on such knowledge as ocean, currents, and vehicle characteristics. Pushes and pulls control levers on console to steer vehicle. Pushes switches to supply power to various units, such as manpower supply and mechanical arms which are located outside of the vehicle and are used to pick up, collect, or move objects on ocean floor. Monitors sonar and navigational aids. Directs subordinates in their activities.

(1) HAWK Gunner

Operates and fires Missile Weapon System to destroy enemy aircraft.
Observes enemy aircraft or receives radar information concerning aircraft.
Notifies superior of target.
Selects appropriate positions for HAWK employment.

(2) HAWK Gunner

Operates and fires HAWK missile weapon system (short range ground to air) missile to destroy low flying enemy aircraft.
Observes low flying enemy aircraft or receives radar information concerning low flying aircraft.
Notifies superior of target.
Selects appropriate primary and alternate positions for HAWK employment considering capabilities and limitations of weapon, friendly troop location and situation in area to be defended and probable aircraft tactics and directions of attack.

(3) HAWK Gunner

Operates and fires HAWK Missile Weapon System to destroy enemy aircraft.
Observes enemy aircraft or receives radar information concerning aircraft.
Evaluates enemy threat, and establishes priority of engagement.
Notifies superior of target.
Presses switches to activate automatic tracking system and fires missile.
Confers with supervisor, using radio to transmit results of firing.
Selects appropriate positions for HAWK employment.

(4) HAWK Gunner

Operates and fires HAWK Missile Weapon System (short range ground to air missile) to destroy low flying enemy aircraft: Observes low flying enemy aircraft. Visually identifies aircraft detected. Evaluates enemy threat, and establishes priority of engagement. Notifies superior of target. Presses switches, upon order, to activate automatic tracking system and fires missile at target. Confers with supervisor, using radio to transmit results of firing. Selects appropriate primary and alternate positions for HAWK employment considering capabilities and limitations of weapon, friendly troop location and situation in area to be defended, and probable aircraft tactics and directions of attack.

(1) Infantry Fighting Vehicle Gunner (IFV Gunner)

Prepares IFV Infantry Fighting Vehicle (IFV) and equipment for combat.
Loads ammunition.
Aims weapon and fires weapon.
Performs preventative maintenance.

(2) Infantry Fighting Vehicle Gunner (IFV Gunner)

Prepares IFV and equipment for movement and combat.
Loads ammunition into breech of weapon.
Aims weapon, using IFV fire control equipment and fires weapon at target.
Performs preventative maintenance and diagnoses and repairs malfunctions associated with the 25MM Gun.

(3) Infantry Fighting Vehicle Gunner (IFV Gunner)

Prepares IFV and equipment for combat.
Fires IFV weapons.
Loads ammunition.
Aims weapon and fires weapon.
Camouflages position and protects against chemical warfare agents.
Decontaminates IFV and equipment.
Performs preventative maintenance.
Maintains surveillance of external environment.

(4) Infantry Fighting Vehicle Gunner (IFV Gunner)

Fires IFV weapons working as member of tank crew.

Prepares IFV and equipment for movement and combat.

Loads ammunition into breech of weapon.

Aims weapon, using IFV fire control equipment and fires weapon at target.

Camouflages position and protects IFV and equipment against chemical warfare agents.

Decontaminates IFV and equipment when exposed to contaminants.

Performs preventative maintenance and diagnoses and repairs malfunctions associated with the 25MM Gun.

Maintains adequate surveillance of external environment with aid of integrated day/night sight (IR display) during periods of low external visibility.

(1) Infantry Fighting Vehicle Commander (IFV Commander)

Supervises and coordinates activities of workers.

Instructs personnel.

Inspects equipment.

(2) Infantry Fighting Vehicle Commander (IFV Commander)

Supervises and coordinates activities of workers engaged in operation and maintenance of Infantry Fighting Vehicle (IFV) and equipment in combat or training.

Instructs personnel in operation of IFV and equipment.

Inspects equipment to determine need for servicing or repair.

(3) Infantry Fighting Vehicle Commander (IFV Commander)

Supervises and coordinates activities of workers.

Instructs personnel

Inspects equipment

Directs workers in servicing or repairing vehicles.

Directs driver in movement of vehicle.

Prepares vehicle journals and worksheets.

(4) Infantry Fighting Vehicle Commander (IFV Commander)

Supervises and coordinates activities of workers engaged in operation and maintenance of IFV and equipment in combat or training.

Instructs personnel in operation of IFV and equipment.

Inspects equipment to determine need for servicing or repair.

Directs workers in servicing or repairing vehicles.

Directs vehicle driver in movement of vehicle in combat situation on land or water.

Prepares vehicle journals and worksheets concerning tactical situations.

(1) Infantry Fighting Vehicle Driver (IFV Driver)

Drives Infantry Fighting Vehicle (IFV).
Transports personnel, supplies, and equipment.
Loads supplies and equipment.
Uses radio to transmit and receive information.
Camouflages position.
Decontaminates IFV and equipment.

(2) Infantry Fighting Vehicle Driver (IFV Driver)

Drives IFV.
Transport personnel, supplies, and equipment in support of combat or training operations.
Uses radio to transmit and receive information concerning enemy locations, troop movement, and enemy gunfire encountered.
Camouflages position.
Decontaminates IFV and equipment when exposed to contaminants.

(3) Infantry Fighting Vehicle Driver (IFV Driver)

Drives IFV.
Transports personnel, supplies, and equipment.
Loads supplies and equipment.
Confers with superior.
Uses radio to transmit and receive information.
Maintains surveillance.
Camouflages position.
Protects IFV and equipment against chemical warfare agents.

(4) Infantry Fighting Vehicle Driver (IFV Driver)

Drives IFV.

Transports personnel, supplies, and equipment in support of combat or training operations.

Loads supplies and equipment aboard vehicle.

Confers with superior to determine course to be followed.

Confers with personnel using radio to transmit and receive information concerning enemy location, troop movement, and enemy gunfire encountered.

Maintains adequate surveillance of external environment with aid of night vision viewer (image intensifier) during periods of low external visibility.

Camouflages position.

Protects IFV and equipment against chemical warfare agents.

Decontaminates IFV and equipment when exposed to contaminants.

(1) Orbital Earth Station Ecology Technician

Serves as crew member in a five person satellite station crew consisting of a commander, two ecology technicians (ET) and two terrestrial conditions monitors (TCM).

Assumes responsibility for life-support systems in the Manned Orbiting Observation Satellite (MOOS).

Activates backup systems and repairs the primary system.

Conducts tests and field investigations to obtain data for use by engineering principles and applied technologies.

Collects samples and assists in evaluation of atmosphere.

Prepares sample for testing, records data and prepares summaries and charts for review.

(2) Orbital Earth Station Ecology Technician

Serves as crew member in a five person satellite station crew consisting of a commander, two ecology technicians (ET) and two terrestrial conditions monitors (TCM).

Assumes primary responsibility for all life-support systems in the Manned Orbiting Observation Satellite (MOOS).

Activates backup systems in the event of a malfunction and then troubleshoots and repairs the primary system.

Conducts tests and field investigations to obtain data for use by environmental, engineering, and scientific personnel.

Utilizes knowledge of chemistry, meteorology, and engineering principles and applied technologies.

Collects samples of gases and other air samples and meteorological data to assist in evaluation of atmosphere.

Prepares sample for testing, records data, and prepares summaries and charts for review.

(3) Orbital Earth Station Ecology Technician

Serves as crew member in a five person satellite station crew consisting of a commander, two ecology technicians (ET) and two terrestrial conditions monitors (TCM).

Assumes responsibility for life-support systems in the Manned Orbiting Observation Satellite (MOOS).

Monitors status of systems to control satellite environment.

Activates backup systems and repairs the primary system.

Conducts tests and field investigations to obtain data utilizing knowledge of chemistry, meteorology, and engineering principles and applied technologies.

Conducts laboratory and field tests to determine characteristics of substances.

Collects samples to assist in evaluation of atmosphere.

Prepares sample for testing, records data, and prepares summaries and charts for review.

Sets equipment to provide information.

Installs, operates, and performs maintenance on test instrumentation.

Operates monitoring or data collection station.

Conducts bacteriological or other tests related to research.

(4) Orbital Earth Station Ecology Technician

Serves as crew member in a five person satellite station crew consisting of a commander, two ecology technicians (ET) and two terrestrial conditions monitors (TCM).

Assumes primary responsibility for life-support systems in the Manned Orbiting Observation Satellite (MOOS).

Monitors status of hydraulic, mechanical, and electrical systems to control satellite environment.

Activates backup systems in the event of a malfunction and then troubleshoots and repairs the primary system.

Conducts tests and field investigations to obtain data for use by environmental, engineering, and scientific personnel.

Utilizes knowledge of chemistry, meteorology, and engineering principles and applied technologies.

Conducts chemical and physical laboratory and field tests according to prescribed standards to determine characteristics or composition of solid liquid or gaseous materials and substances, using pH meter, chemicals, autoclaves, centrifuge, spectrophotometer, microscope, analytical instrumentation and chemical laboratory equipment.

Collects samples of gases and other air samples and meteorological data to assist in evaluation of atmosphere.

Prepares sample for testing, records data, and prepares summaries and charts for review.

Sets monitoring equipment to provide flow of information.

Installs, operates, and performs routine maintenance on gas and fluid flow systems, chemical reaction systems, mechanical equipment and other test instrumentation.

(1) Mechanized Commando

Operates a one-man Mechanized Armored Carrier (MAC).

Prepares MAC and equipment for combat.

Confers with superior.

Uses radio to transmit and receive information.

Loads ammunition.

Aims and fires weapon.

Decontaminates MAC and equipment.

Performs preventative maintenance.

(2) Mechanized Commando

Operates a one-man Mechanized Armored Carrier (MAC) in combat situation on land or water.

Prepares MAC and equipment for movement and combat.

Confers with superior to determine course to be followed.

Confers with personnel using radio to transmit and receive information concerning enemy location, troop movement, and enemy gunfire encountered.

Loads ammunition into the breech of the weapon.

Aims weapons using MAC fire control equipment and fires weapon at target.

Decontaminates MAC and equipment when exposed to contaminants.

Performs preventative maintenance.

(3) Mechanized Commando

Operates a one-man Mechanized Armored Carrier.
Prepares MAC and equipment for combat.
Loads supplies and equipment.
Confers with superior.
Uses radio to transmit and receive information.
Prepares vehicle journals and worksheets.
Loads ammunition.
Aims and fires weapon.
Camouflages position.
Protects MAC and equipment against chemical warfare agents.
Decontaminates MAC and equipment.
Inspects vehicle and equipment.
Performs preventative maintenance.
Diagnoses and repairs malfunctions while in the field.
Instructs personnel.

(4) Mechanized Commando

Operates a one-man Mechanized Armored Carrier (MAC) in combat situation on land or water.

Prepares MAC and equipment for movement and combat.

Loads supplies and equipment aboard MAC.

Confers with superior to determine course to be followed.

Confers with personnel using radio to transmit and receive information concerning enemy location, troop movement, and enemy gunfire encountered.

Prepares vehicle journals and worksheets concerning tactical situation.

Loads ammunition into the breech of the weapon.

Aims weapons using MAC fire control equipment and fires weapon at target.

Maintains adequate surveillance of external environment with aid of night vision viewer during periods of low external visibility.

Camouflages position.

Protects MAC and equipment against chemical warfare agents.

Decontaminates MAC and equipment when exposed to contaminants.

Inspects vehicle and equipment to determine need for servicing or repair.

Performs preventative maintenance.

Diagnoses and repairs malfunctions of the vehicle and weapons during combat and training situations while in the field.

Instructs personnel in the operation of the MAC and its equipment.

Section 2. Worker-Oriented Job Descriptions

Worker-oriented job descriptions presented in this section are based on the traits that an individual must possess to accomplish a job. Two formats, narrative and tabular, have been used to provide worker-oriented job descriptions.

The narrative format job description provides information concerning the worker attributes and specific skills associated with the job described. The tabular format job description provides information regarding physical and aptitude characteristics. These characteristics are identified on the left side of each table. The specific job requirements are listed on the right side of the table. Since the jobs described are military occupations, the requirements were based on the characteristics of Army personnel. For example, a reference to the top third of the population pertains to an estimate of the characteristics of Army personnel, not the population of the United States.

(5) Light Truck Driver

An occupationally significant combination of: Spatial discrimination; eye-hand-foot coordination; manual dexterity; a preference for working with machines and equipment; the ability to follow instructions; and facility in adapting to routine, repetitive work.

(6) WORKER REQUIREMENTS: LIGHT TRUCK DRIVER

STRENGTH	50 LBS.
OPERATIONS	STOOP, CROUCH, REACH, FINGER, KNEEL, CRAWL, HANDLE, FEEL
HEARING	
SPEECH	
VISION	20/20
VOCATIONAL PREPARATION	30 DAYS - 3 MONTHS

APTITUDES:

INTELLEGECE	MIDDLE 1/3 OF POPULATION
VERBAL	
NUMERICAL	
SPATIAL	MIDDLE 1/3 OF POPULATION
FORM PERCEPTION	
MOTOR COORDINATION	MIDDLE 1/3 OF POPULATION
FINGER DEXTERITY	
MANUAL DEXTERITY	MIDDLE 1/3 OF POPULATION
HAND-EYE-FOOT COORDINATION	MIDDLE 1/3 OF POPULATION
COLOR DISCRIMINATION	
CLERICAL PERCEPTION	

(5) Mechanic

An occupationally significant combination of: Ability to learn and apply techniques, processes, and principles; ability to use independent judgement in planning sequence of operations and in selecting proper tools and material; ability to assume responsibility for attainment of prescribed qualitative standards; ability to apply shop mathematics to practical problems; such as computing dimensions and locating reference points from specifications data when laying out work; spatial perception to visualize arrangements and relationships of static or moving parts and assemblies represented in blueprints and diagrams; form perception as required in such activities as inspecting finished work to verify acceptability of surface finish; and some combination of finger manual dexterity and eye-hand coordination to use handtools and manually controlled power tools when executing work to close tolerances.

(6) WORKER REQUIREMENTS: MECHANIC

STRENGTH	50 LBS.
OPERATIONS	STOOP, KNEEL, CROUCH, CRAWL, REACH, HANDLE, FINGER, FEEL
HEARING	
SPEECH	
VISION	
VOCATIONAL PREPARATION	6 MONTHS

APTITUDES:

INTELLEGENCE	MIDDLE 1/3 OF POPULATION
VERBAL	MIDDLE 1/3 OF POPULATION
NUMERICAL	MIDDLE 1/3 OF POPULATION
SPATIAL	TOP 1/3 OF POPULATION
FORM PERCEPTION	MIDDLE 1/3 OF POPULATION
MOTOR COORDINATION	MIDDLE 1/3 OF POPULATION
FINGER DEXTERITY	MIDDLE 1/3 OF POPULATION
MANUAL DEXTERITY	MIDDLE 1/3 OF POPULATION
HAND-EYE-FOOT COORDINATION	
COLOR DISCRIMINATION	
CLERICAL PERCEPTION	

(5) Military Police

An occupationally significant combination of: Capacity to acquire knowledge of laws and regulations and learn investigative procedures and methods; verbal ability to converse with people at varied levels; tact and diplomacy in order to establish rapport with people; ability to perform under stress and maintain equanimity in the face of danger or resistance; organizational ability in order to gather and evaluate facts; and assurance of manner will gain confidence and respect; and physical stamina.

(6) WORKER REQUIREMENTS: MILITARY POLICE

STRENGTH	20 LBS.
OPERATIONS	
HEARING	TOP 1/3 OF POPULATION
SPEECH	MIDDLE 1/3 OF POPULATION
VISION	20/20
VOCATIONAL PREPARATION	3 - 6 MONTHS

APTITUDES:

INTELLEGENCE	TOP 1/3 OF POPULATION
VERBAL	TOP 1/3 OF POPULATION
NUMERICAL	MIDDLE 1/3 OF POPULATION
SPATIAL	
FORM PERCEPTION	
MOTOR COORDINATION	
FINGER DEXTERITY	
MANUAL DEXTERITY	
HAND-EYE-FOOT COORDINATION	
COLOR DISCRIMINATION	
CLERICAL PERCEPTION	

(5) Computer Operator

An occupationally significant combination of: The ability and willingness to follow instructions in performing work of a routine organized nature; attention to detail and good reading comprehension in order to avoid clerical errors; form and spatial perception eye-hand coordination, and finger and manual dexterity for using machines; and an inclination toward working with machines.

(6) WORKER REQUIREMENTS: COMPUTER OPERATOR

STRENGTH	20 LBS.
OPERATIONS	REACH, FINGER, HANDLE, FEEL
HEARING	
SPEECH	
VISION	
VOCATIONAL PREPARATION	3 MONTHS - 6 MONTHS

APTITUDES:

INTELLEGENCE	MIDDLE 1/3 OF POPULATION
VERBAL	MIDDLE 1/3 OF POPULATION
NUMERICAL	
SPATIAL	MIDDLE 1/3 OF POPULATION
FORM PERCEPTION	TOP 1/3 OF POPULATION
MOTOR COORDINATION	MIDDLE 1/3 OF POPULATION
FINGER DEXTERITY	MIDDLE 1/3 OF POPULATION
MANUAL DEXTERITY	MIDDLE 1/3 OF POPULATION
HAND-EYE-FOOT COORDINATION	
COLOR DISCRIMINATION	
CLERICAL PERCEPTION	TOP 1/3 OF POPULATION

(5) Missile Facilities Repairer

An occupationally significant combination of: Ability to learn and apply techniques, processes, and principles; ability to use independent judgement in planning sequence of operations and in selecting proper tools and materials; ability to assume responsibility for attainment of prescribed qualitative standards; ability to apply shop mathematics to practical problems, such as computing dimensions and locating reference points from specifications data when laying out work; spatial perception to visualize arrangements and relationships of static or moving parts and assemblies represented in blueprints and diagrams; form perception as required in such activities as inspecting finished work to verify accept of surface finish; and some combination of finger and manual dexterity and eye-hand coordination to use handtools and manually controlled power tools when executing work to close tolerances.

(6) WORKER REQUIREMENTS: MISSILE FACILITIES REPAIRMAN

STRENGTH	100 LBS.
OPERATIONS	REACH, FINGER, STOOP, CROUCH, HANDLE, FEEL, KNEEL, CRAWL
HEARING	
SPEECH	
VISION	
VOCATIONAL PREPARATION	1 - 2 YEARS

APTITUDES:

INTELLEGECE	MIDDLE 1/3 OF POPULATION
VERBAL	MIDDLE 1/3 OF POPULATION
NUMERICAL	MIDDLE 1/3 OF POPULATION
SPATIAL	TOP 1/3 OF POPULATION
FORM PERCEPTION	MIDDLE 1/3 OF POPULATION
MOTOR COORDINATION	MIDDLE 1/3 OF POPULATION
FINGER DEXTERITY	MIDDLE 1/3 OF POPULATION
MANUAL DEXTERITY	MIDDLE 1/3 OF POPULATION
HAND-EYE-FOOT COORDINATION	
COLOR DISCRIMINATION	
CLERICAL PERCEPTION	

(5) Deep Submergence Vehicle Operator

An occupationally significant combination of: Ability to learn principles and techniques of navigation; eye-hand coordination; manual and finger dexterity and motor coordination; spatial and form perception; spatial perception to visualize three dimensional forms and arrangements; ability to adjust to a confined environment and to work cooperatively within a small team; and ability to adjust to a routine.

(6) WORKER REQUIREMENTS: DEEP SUBMERGENCY VEHICLE OPERATOR

STRENGTH	50 LBS.
OPERATIONS	CLIMB, BALANCE, STOOP, KNEEL, CROUCH, CRAWL, REACH, HANDLE, FINGER, FEEL
HEARING	
SPEECH	
VISION	TOP 1/3 OF POPULATION
VOCATIONAL PREPARATION	1 - 2 YEARS

APTITUDES:

INTELLEGECE	TOP 1/3 OF POPULATION
VERBAL	MIDDLE 1/3 OF POPULATION
NUMERICAL	
SPATIAL	TOP 1/3 OF POPULATION
FORM PERCEPTION	MIDDLE 1/3 OF POPULATION
MOTOR COORDINATION	MIDDLE 1/3 OF POPULATION
FINGER DEXTERITY	TOP 1/3 OF POPULATION
MANUAL DEXTERITY	TOP 1/3 OF POPULATION
HAND-EYE-FOOT COORDINATION	MIDDLE 1/3 OF POPULATION
COLOR DISCRIMINATION	
CLERICAL PERCEPTION	

(5) HAWK Gunner

An occupationally significant combination of: An interest in working with the hands; manual and finger dexterity; eye hand coordination, the ability to perceive small differences in things and objects and spatial relationships; and the ability to work to prescribed tolerances and rigid standard.

(6) WORKER REQUIREMENTS: HAWK GUNNER

STRENGTH	50 LBS.
OPERATIONS	STOOP, KNEEL, CROUCH, CRAWL, REACH, HANDLE, FINGER, FEEL
HEARING	TOP 25% OF POPULATION
SPEECH	
VISION	TOP 10% OF POPULATION
VOCATIONAL PREPARATION	6 MONTHS - 1 YEAR

APTITUDES:

INTELLEGECE	TOP 1/3 OF POPULATION
VERBAL	MIDDLE 1/3 OF POPULATION
NUMERICAL	
SPATIAL	TOP 10% OF POPULATION
FORM PERCEPTION	MIDDLE 1/3 OF POPULATION
MOTOR COORDINATION	TOP 10% OF POPULATION
FINGER DEXTERITY	TOP 10% OF POPULATION
MANUAL DEXTERITY	TOP 1/3 OF POPULATION
HAND-EYE-FOOT COORDINATION	
COLOR DISCRIMINATION	
CLERICAL PERCEPTION	

(5) Infantry Fighting Vehicle Gunner (IFV Gunner)

An occupationally significant combination of: An interest in working with the hands; manual and finger dexterity; eye-hand coordination; the ability to perceive small differences in things and objects, and spatial relationships; and the ability to work to prescribed tolerances and rigid standards.

(6) WORKER REQUIREMENTS: IFV GUNNER

STRENGTH	50 LBS.
OPERATIONS	REACH, HANDLE, FINGER, FEEL
HEARING	TOP 25% OF POPULATION
SPEECH	
VISION	TOP 10% OF POPULATION
VOCATIONAL PREPARATION	6 MONTHS - 1 YEAR

APTITUDES:

INTELLEGENCE	TOP 1/3 OF POPULATION
VERBAL	
NUMERICAL	
SPATIAL	TOP 25% OF POPULATION
FORM PERCEPTION	MIDDLE 1/3 OF POPULATION
MOTOR COORDINATION	TOP 10% OF POPULATION
FINGER DEXTERITY	TOP 10% OF POPULATION
MANUAL DEXTERITY	TOP 1/3 OF POPULATION
HAND-EYE-FOOT COORDINATION	
COLOR DISCRIMINATION	
CLERICAL PERCEPTION	

(5) Infantry Fighting Vehicle Commander (IFV Commander)

An occupationally significant combination of: Organizational ability to plan, formulate and execute strategies and tactics; capacity to acquire knowledge of various concepts and practices and successfully apply them to different environments; verbal facility to deal effectively with persons at all levels; flexibility to adjust to changing conditions; and an analytical mind to solve problems.

(6) WORKER REQUIREMENTS: IFV COMMANDER

STRENGTH	20 LBS.
OPERATIONS	CLIMB, BALANCE, STOOP, KNEEL, CROUCH, CRAWL, REACH, HANDLE, FINGER, FEEL
HEARING	TOP 1/3 OF POPULATION
SPEECH	MIDDLE 1/3 OF POPULATION
VISION	TOP 1/3 OF POPULATION
VOCATIONAL PREPARATION	1 YEAR

APTITUDES:

INTELLEGENCE	MIDDLE 1/3 OF POPULATION
VERBAL	MIDDLE 1/3 OF POPULATION
NUMERICAL	
SPATIAL	TOP 10% OF POPULATION
FORM PERCEPTION	TOP 1/3 OF POPULATION
MOTOR COORDINATION	MIDDLE 1/3 OF POPULATION
FINGER DEXTERITY	MIDDLE 1/3 OF POPULATION
MANUAL DEXTERITY	MIDDLE 1/3 OF POPULATION
HAND-EYE-FOOT COORDINATION	MIDDLE 1/3 OF POPULATION
COLOR DISCRIMINATION	
CLERICAL PERCEPTION	

(5) Infantry Fighting Vehicle Driver (IFV Driver)

An occupationally significant combination of: Spatial discrimination; eye-hand-foot coordination; manual dexterity; a preference for working with machines and equipment; the ability to follow instructions, and facility in adapting to routine.

(6) WORKER REQUIREMENTS: IFV DRIVER

STRENGTH	50 LBS.
OPERATIONS	STOOP, CROUCH, REACH, FINGER, KNEEL, CRAWL, HANDLE, FEEL
HEARING	TOP 1/3 OF POPULATION
SPEECH	
VISION	20/20
VOCATIONAL PREPARATION	6 MONTHS

APTITUDES:

INTELLEGECE	MIDDLE 1/3 OF POPULATION
VERBAL	MIDDLE 1/3 OF POPULATION
NUMERICAL	
SPATIAL	MIDDLE 1/3 OF POPULATION
FORM PERCEPTION	
MOTOR COORDINATION	TOP 1/3 OF POPULATION
FINGER DEXTERITY	MIDDLE 1/3 OF POPULATION
MANUAL DEXTERITY	MIDDLE 1/3 OF POPULATION
HAND-EYE-FOOT COORDINATION	MIDDLE 1/3 OF POPULATION
COLOR DISCRIMINATION	MIDDLE 1/3 OF POPULATION
CLERICAL PERCEPTION	

(5) Orbital Station Ecology Technician

An occupationally significant combination of: Intellectual ability and interest sufficient to acquire necessary academic background; attention to details; a facility with mathematics; and form perception to recognize physical differences in material.

(6) WORKER REQUIREMENTS: ORBITAL STATION ECOLOGY TECHNICIAN

STRENGTH	20 LBS.
OPERATIONS	CLIMB, BALANCE, STOOP, KNEEL, CROUCH, CRAWL, REACH, HANDLE, FINGER, FEEL
HEARING	MIDDLE 1/3 OF POPULATION
SPEECH	MIDDLE 1/3 OF POPULATION
VISION	TOP 1/3 OF POPULATION
VOCATIONAL PREPARATION	1 - 2 YEARS

APTITUDES:

INTELLEGENCE	TOP 10% OF POPULATION
VERBAL	TOP 1/3 OF POPULATION
NUMERICAL	TOP 10% OF POPULATION
SPATIAL	TOP 10% OF POPULATION
FORM PERCEPTION	MIDDLE 1/3 OF POPULATION
MOTOR COORDINATION	TOP 10% OF POPULATION
FINGER DEXTERITY	TOP 10% OF POPULATION
MANUAL DEXTERITY	TOP 10% OF POPULATION
HAND-EYE-FOOT COORDINATION	MIDDLE 1/3 OF POPULATION
COLOR DISCRIMINATION	MIDDLE 1/3 OF POPULATION
CLERICAL PERCEPTION	TOP 10% OF POPULATION

(5) *Mechanized Commando*

An occupationally significant combination of: Organizational ability to plan, formulate, and execute strategies and tactics; capacity to acquire knowledge of various concepts and practices and successfully apply them to different environments; manual and finger dexterity with eye-hand-foot coordination; ability to perceive small differences in things and objects, and spatial relationships; flexibility to adjust to changing conditions; ability to be self motivated and assume responsibility.

C51

(6) WORKER REQUIREMENTS: MECHANIZED COMMANDO

STRENGTH	50 LBS.
OPERATIONS	BALANCE, STOOP, KNEEL, CROUCH, CRAWL, REACH, HANDLE, FINGER, FEEL
HEARING	TOP 25% OF POPULATION
SPEECH	MIDDLE 1/3 OF POPULATION
VISION	20/20
VOCATIONAL PREPARATION	6 MONTHS - 1 YEAR

APTITUDES:

INTELLEGEENCE	TOP 1/3 OF POPULATION
VERBAL	MIDDLE 1/3 OF POPULATION
NUMERICAL	
SPATIAL	TOP 10% OF POPULATION
FORM PERCEPTION	TOP 1/3 OF POPULATION
MOTOR COORDINATION	TOP 10% OF POPULATION
FINGER DEXTERITY	TOP 10% OF POPULATION
MANUAL DEXTERITY	TOP 1/3 OF POPULATION
HAND-EYE-FOOT COORDINATION	MIDDLE 1/3 OF POPULATION
COLOR DISCRIMINATION	
CLERICAL PERCEPTION	

Section 3. Job Illustrations

This section contains four illustrations - one each for the HAWK gunner, the IFV gunner, the orbital earth station ecology technician, and the mechanized commando. These illustrations provide visual job information to the job analyst. When combined with a written job description, the illustration provides a greater understanding of what the job entails. In future research, the previously mentioned illustrations will be used with the written job description of cell (2) and cell (4) of the job-oriented matrix and the written narrative of the worker-oriented job description.

HAWK BATTERY

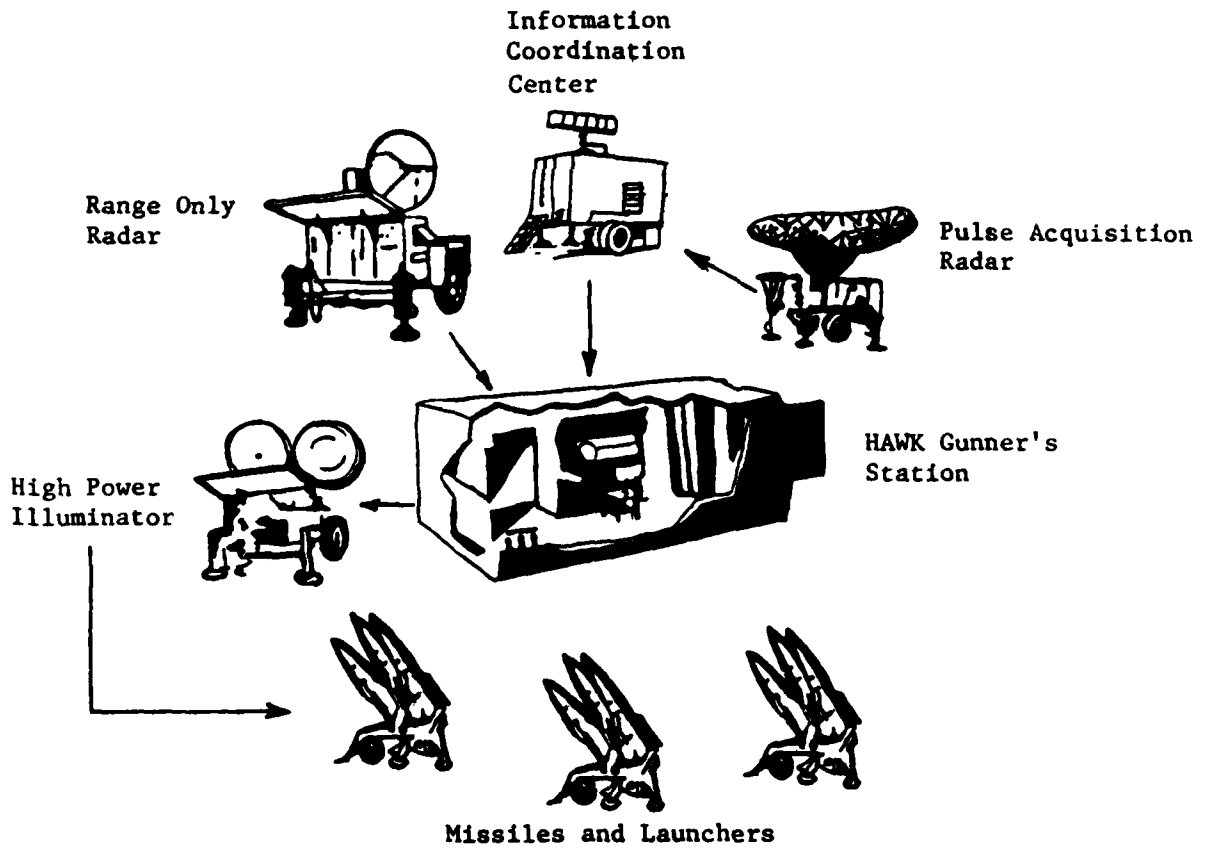

C54

INFANTRY FIGHTING VEHICLE GUNNER

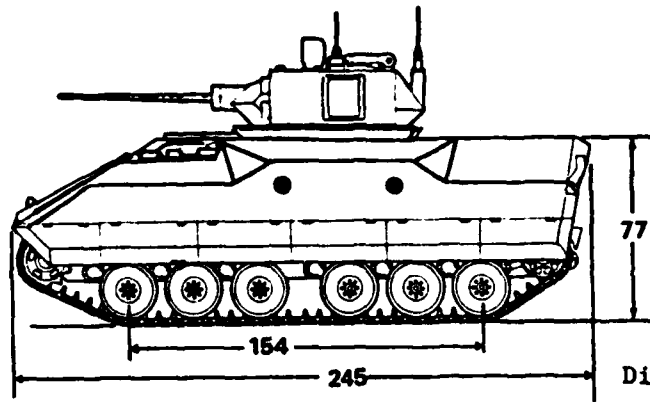

Dimensions in Inches

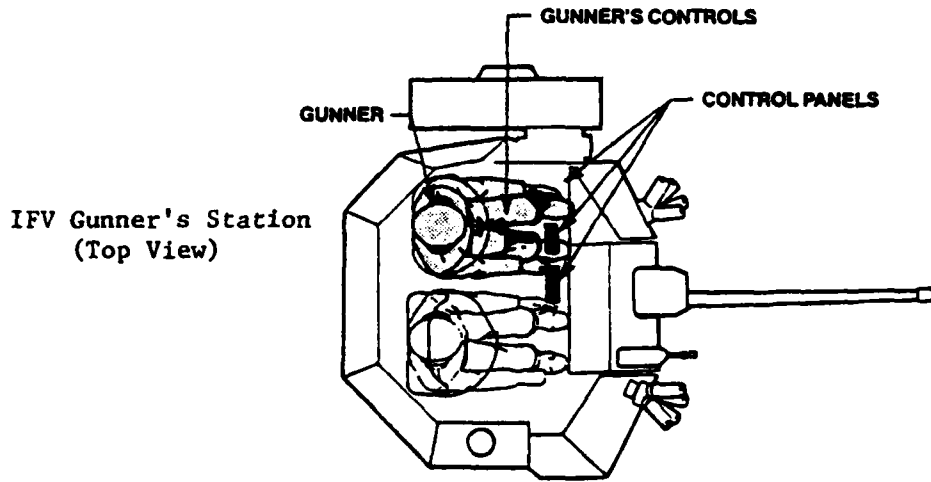

IFV Gunner's Station
(Top View)

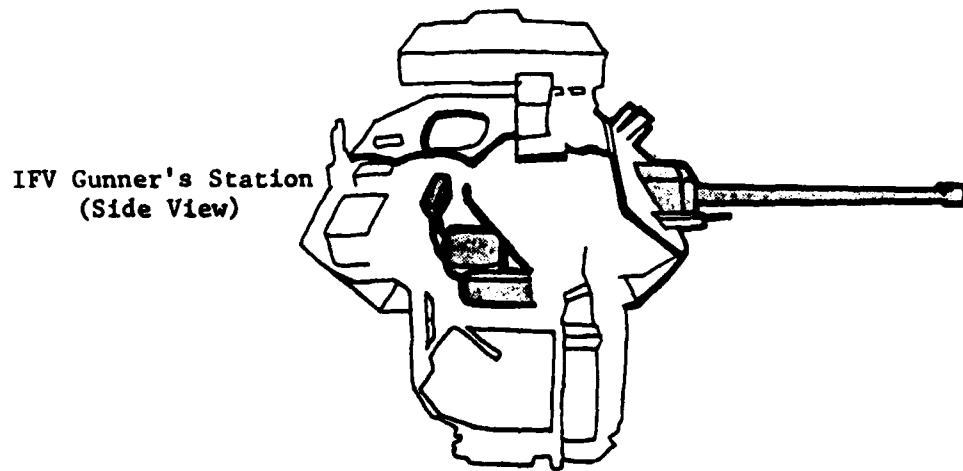

IFV Gunner's Station
(Side View)

ORBITAL EARTH STATION ECOLOGY TECHNICIAN

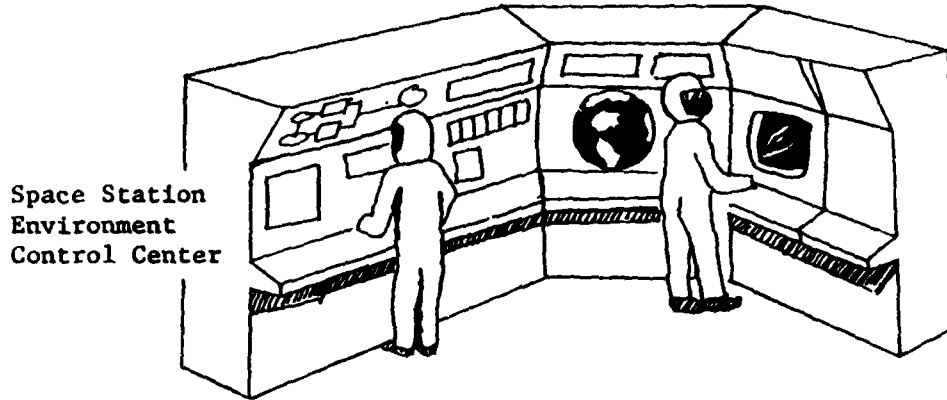

ECOLOGY TECHNICIAN'S DUTY STATION

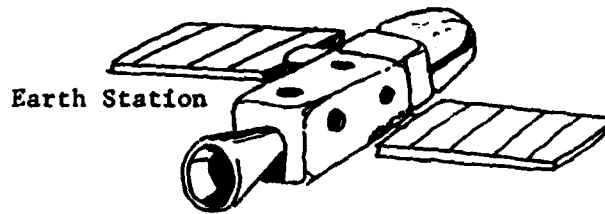

PRELIMINARY CONCEPT DESIGN SKETCH

C56

MECHANIZED COMMANDO

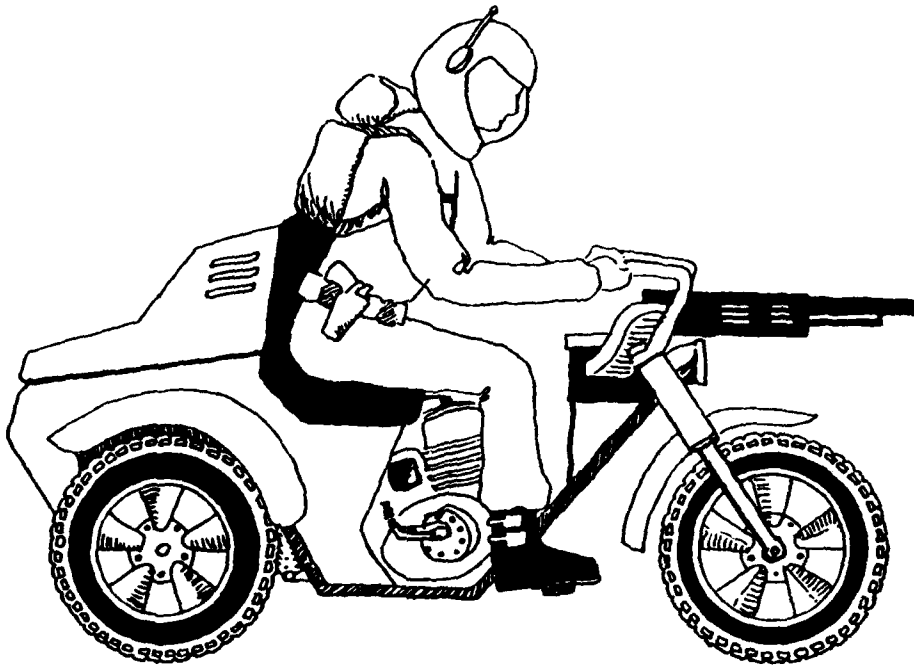

PRELIMINARY DESIGN CONCEPT SKETCH